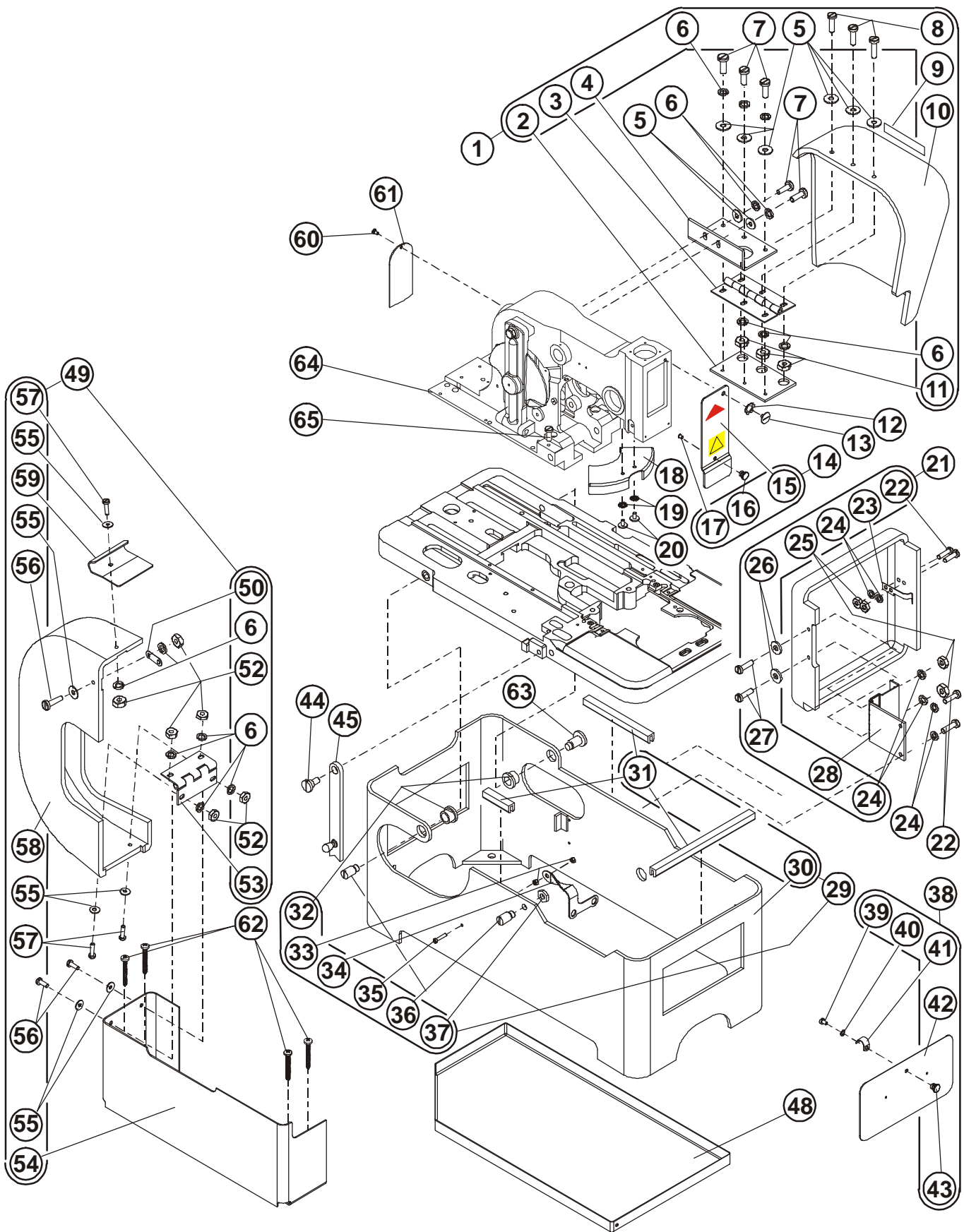

TABLE OF CONTENTS

Covers & Supporting Members	3-2
Drive Shaft	3-6
Main Cam and Brake Band	3-8
Starting lever and switch lever assembly	3-10
Combination Lateral Lever	3-12
Flybar Control & Turning Sectors & Levers	3-14
Race	3-16
Thread Take up & Looper Drive	3-20
Upper Thread Trimmer	3-22
Clamp Yoke Assembly	3-24
Cutting Lever Assembly	3-28
Length Gauge	3-30
Stitch Feed	3-32
Three Fork Lever	3-34
Rocking Lever	3-36
Needle Bar Drive and Vibrator	3-40
Needle Bar and Gear	3-42
Thread Handling	3-44
Regular Table	3-48
Tools, Supples & Accessories	3-50

COVERS & SUPPORTING MEMBERS



Released 09/2007

E-mail: service@amfreece.cz; parts@amfreece.cz ; website: www.amfreece.com
Phones: +420 582 309 146 (Service), +420 582 309 286 (Spare Parts) ; Fax: +420 582 360 606

COVERS & SUPPORTING MEMBERS

DET	PART NUMBER	DESCRIPTION	QTY.
01	10.1194.0.023	Top Right Cover Assembly	1
02	10.1194.0.020	Cover Support	(1)
03	10.1194.0.008	Hinge	(1)
04	01.1194.0.019	Hinge Support	(1)
05	01.4472.0.000	Washer	(3)+2
06	01.4407.0.000	Lock Washer	(4)+10
07	01.2247.0.003	Screw	(3)+2
08	01.2247.0.001	Screw	(3)
09	12.8000.1.001	Label	(1)
10	10.1194.0.004	Right Bottom Cover	(1)
11	01.3402.0.000	Nut	(3)
12	01.5062.0.000	Spring Washer	1
13	10.1151.0.000	Screw	1
14	10.1082.0.051	Plate - Cover *Front Assembly	1
15	10.1082.0.001	Plate	(1)
16	01.3040.0.000	Knob	(1)
17	01.2101.0.000	Screw	(1)
18	10.1145.2.000	Shield	1
19	01.4672.0.002	Lock Washer	1
20	01.2078.0.000	Screw	1
21	10.1194.0.024	Top Right Cover Assembly	1
22	01.2241.0.103	Screw	(4)+2
23	10.1194.0.009	Clip	(1)
24	01.4406.0.000	Lock Washer	(4)+2
25	01.3401.0.000	Nut	(2)
26	01.4411.0.000	Washer	(2)
27	01.2241.0.103	Screw	(2)
28	10.1194.1.012	Hinge	(1)
29	10.5001.2.051	Line Stand Assembly	1
30	10.5001.2.000	Stand	(1)
31	05.1385.0.000	U - Chanel Eding	(1)
32	01.7329.0.000	Oilite Bushing	(2)
33	01.3001.0.000	Nut	(2)
34	10.5002.0.000	Thread Guide	(1)
35	01.2888.0.402	Screw	(1)
36	10.2003.0.000	Hinge Screw	1+(1)
37	01.3014.0.000	Nut	(1)
38	10.0625.0.000	Cover Front	1
39	01.2050.0.000	Screw	(1)
40	01.4019.0.000	Washer	(1)
41	10.5006.1.000	Clip	(1)
42	10.5005.1.900	Cover	(1)
43	01.3040.0.000	Knob	(1)
44	10.2004.1.000	Screw	1
45	10.2005.0.000	Latch	1
46			
47			
48	10.5021.0.000	Oil Pan	1
49	10.1194.0.025	L.H. Cover Aqssembly	1
50	01.5123.0.000	Spring	(1)

Released 09/2007

E-mail: service@amfreece.cz; parts@amfreece.cz; website: www.amfreece.com

Phones: +420 582 309 146 (Service), +420 582 309 286 (Spare Parts); Fax: +420 582 360 606

COVERS & SUPPORTING MEMBERS

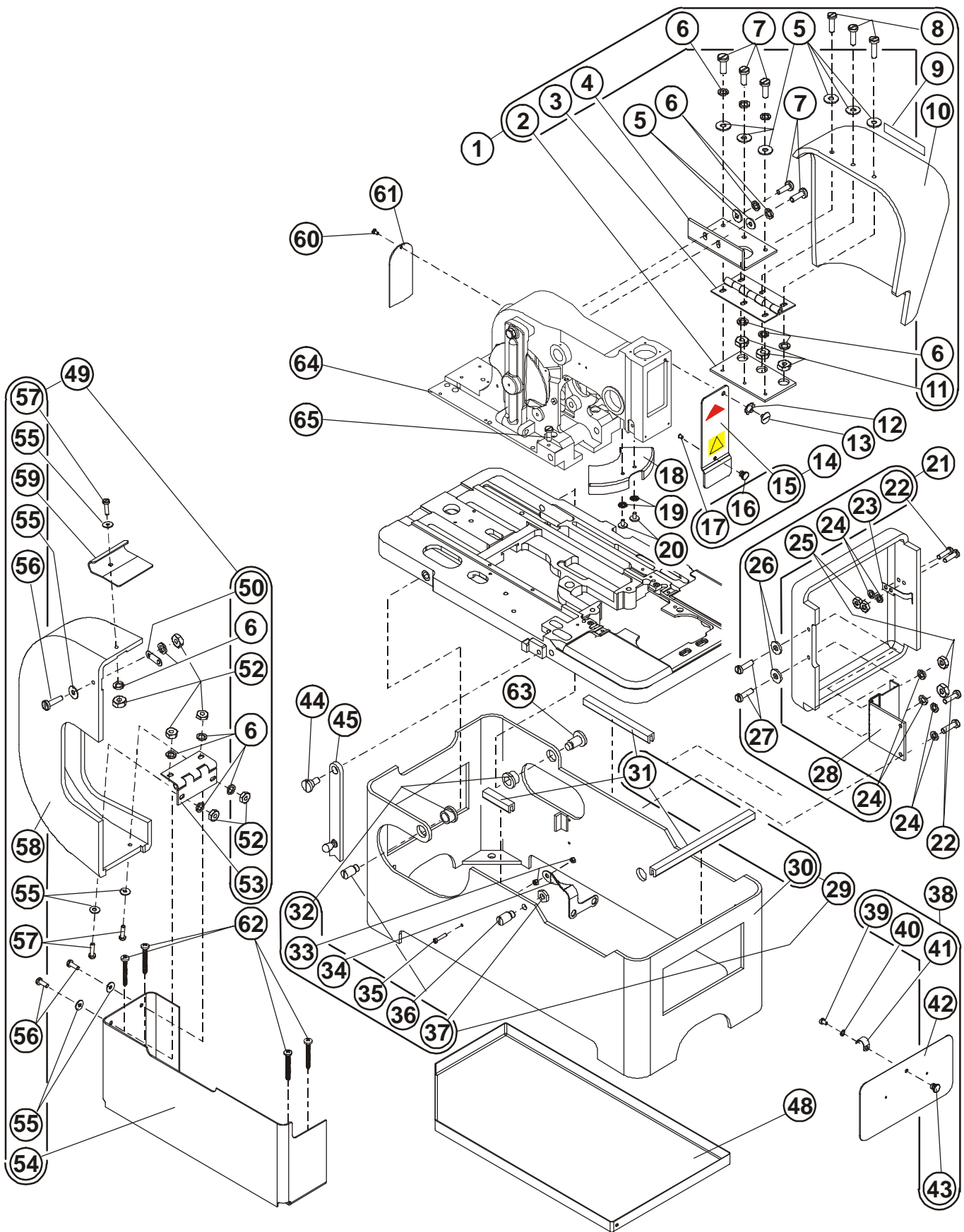

Released 09/2007

E-mail: service@amfreece.cz; parts@amfreece.cz ; website: www.amfreece.com
Phones: +420 582 309 146 (Service), +420 582 309 286 (Spare Parts) ; Fax: +420 582 360 606

COVERS & SUPPORTING MEMBERS

DET	PART NUMBER	DESCRIPTION	QTY.
51			
52	01.3402.0.000	Nut	(6)
53	10.1194.0.010	Hinge	(1)
54	10.1194.2.006	Left Bottom Cover	(1)
55	01.4472.0.000	Washer	(6)
56	01.2247.0.003	Screw	(3)
57	01.2247.0.001	Screw	(3)
58	10.1194.1.005	Top Left Cover	(1)
59	10.1194.0.028	Latch	(1)
60	10.1081.0.000	Screw	1
61	10.1080.0.000	Cover	1
62	01.2547.1.441	Screw	4
63	10.2017.0.000	Hinge Screw	1
64	10.1001.7.050	Head White	1
65	01.1147.0.003	Screw	1

Released 09/2007

E-mail: service@amfreece.cz; parts@amfreece.cz ; website: www.amfreece.com

Phones: +420 582 309 146 (Service), +420 582 309 286 (Spare Parts) ; Fax: +420 582 360 606

DRIVE SHAFT

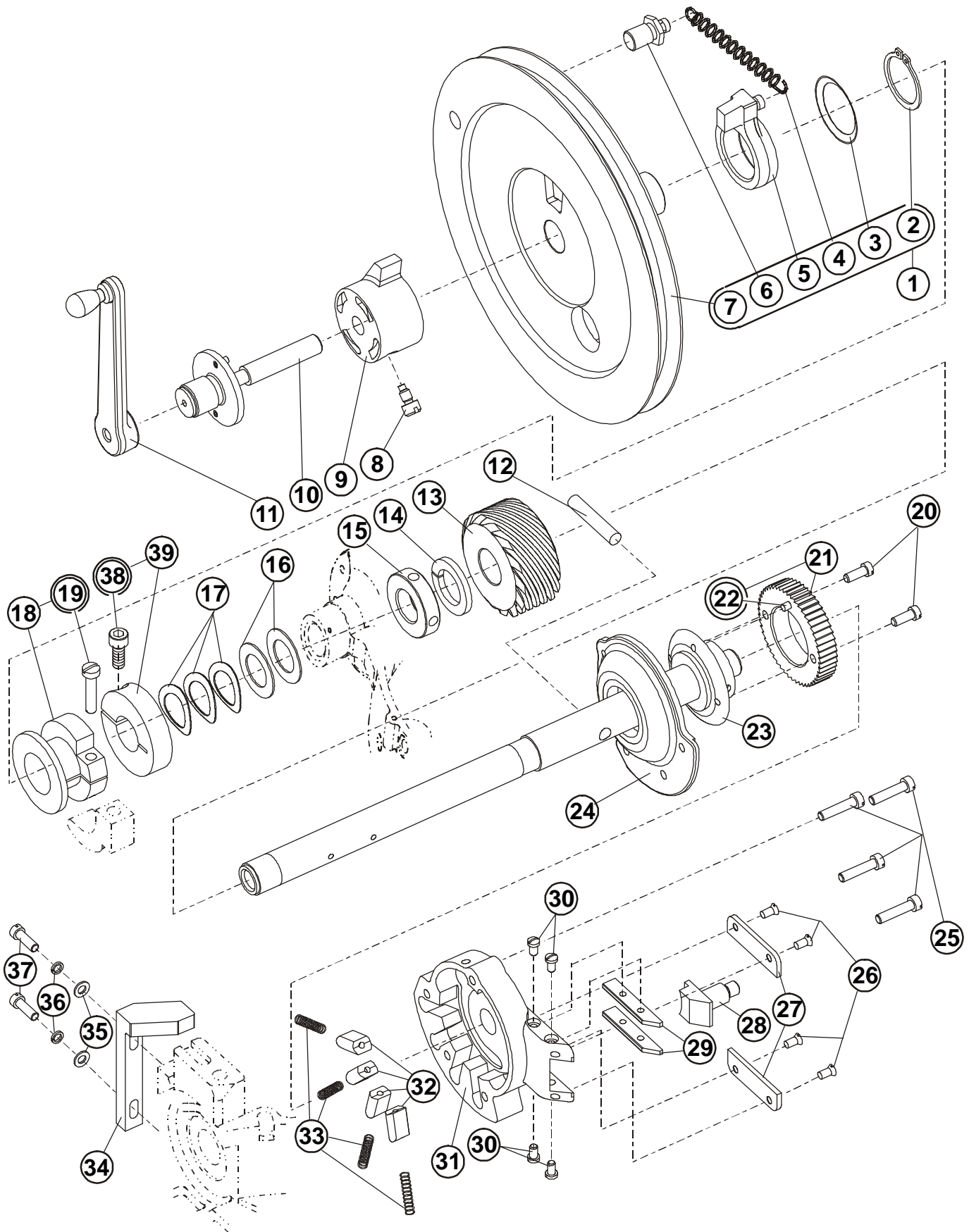

Released 09/2007

E-mail: service@amfreece.cz; parts@amfreece.cz ; website: www.amfreece.com
 Phones: +420 582 309 146 (Service), +420 582 309 286 (Spare Parts) ; Fax: +420 582 360 606

MAIN CAM AND BRAKE BAND

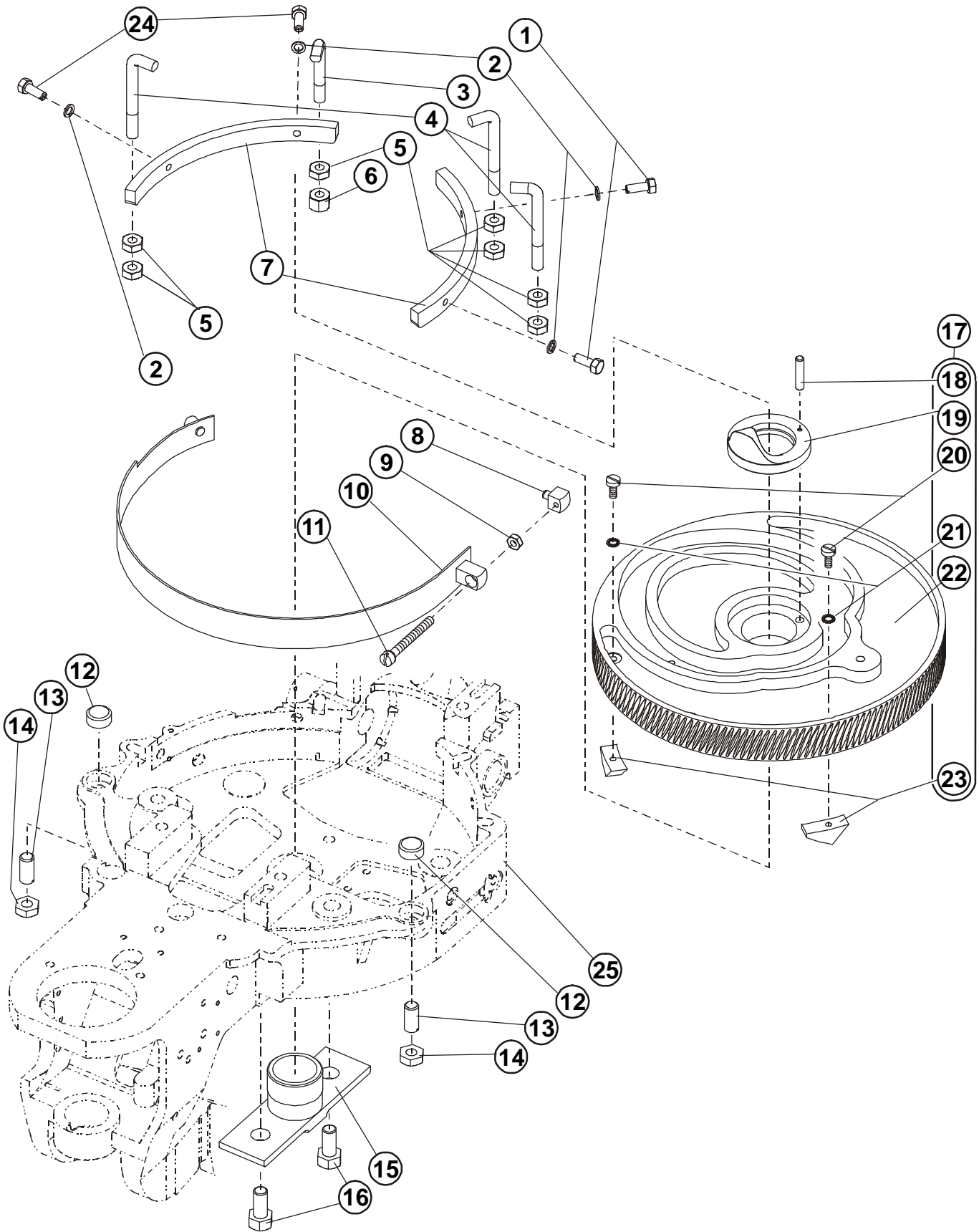

Released 09/2007

E-mail: service@amfreece.cz; parts@amfreece.cz ; website: www.amfreece.com
Phones: +420 582 309 146 (Service), +420 582 309 286 (Spare Parts) ; Fax: +420 582 360 606

MAIN CAM AND BRAKE BAND

DET	PART NUMBER	DESCRIPTION	QTY.
01	01.2386.0.000	Screw	2
02	01.4018.0.000	Washer	4
03	10.3066.0.008	Short Hook	1
04	10.3066.0.011	Long Hook	3
05	01.3007.0.000	Nut	6
06	01.3059.0.000	Nut	1
07	10.3035.1.000	Hold Down Gib	2
08	01.6345.0.000	Lug	1
09	01.3005.0.000	Nut	1
10	10.3036.0.000	Brake Band	1
11	01.2033.0.000	Screw	1
12	10.3028.0.000	Button	2
13	01.2067.0.000	Adjustments Screw	2
14	01.3015.0.000	Nut	2
15	10.3027.0.000	Cam Center	1
16	01.2031.0.000	Screw	2
17	10.3064.0.830	Main Cam Assembly	1
18	—	Pin	(1)
19	10.3062.1.000	Cam - Cutting* CB/CA	(1)
20	01.2347.0.000	Screw	(2)
21	01.4061.0.000	Washer	(2)
22	14.3064.0.001	Main Cam	(1)
23	10.3061.0.300	Wedge - Clamping CB/CA	(2)
24	01.2388.0.000	Screw	2
25	10.3001.3.000	Cam Case	1

Released 09/2007

E-mail: service@amfreece.cz; parts@amfreece.cz ; website: www.amfreece.com

Phones: +420 582 309 146 (Service), +420 582 309 286 (Spare Parts) ; Fax: +420 582 360 606

STARTING LEVER AND SWITCH LEVER ASSEMBLY

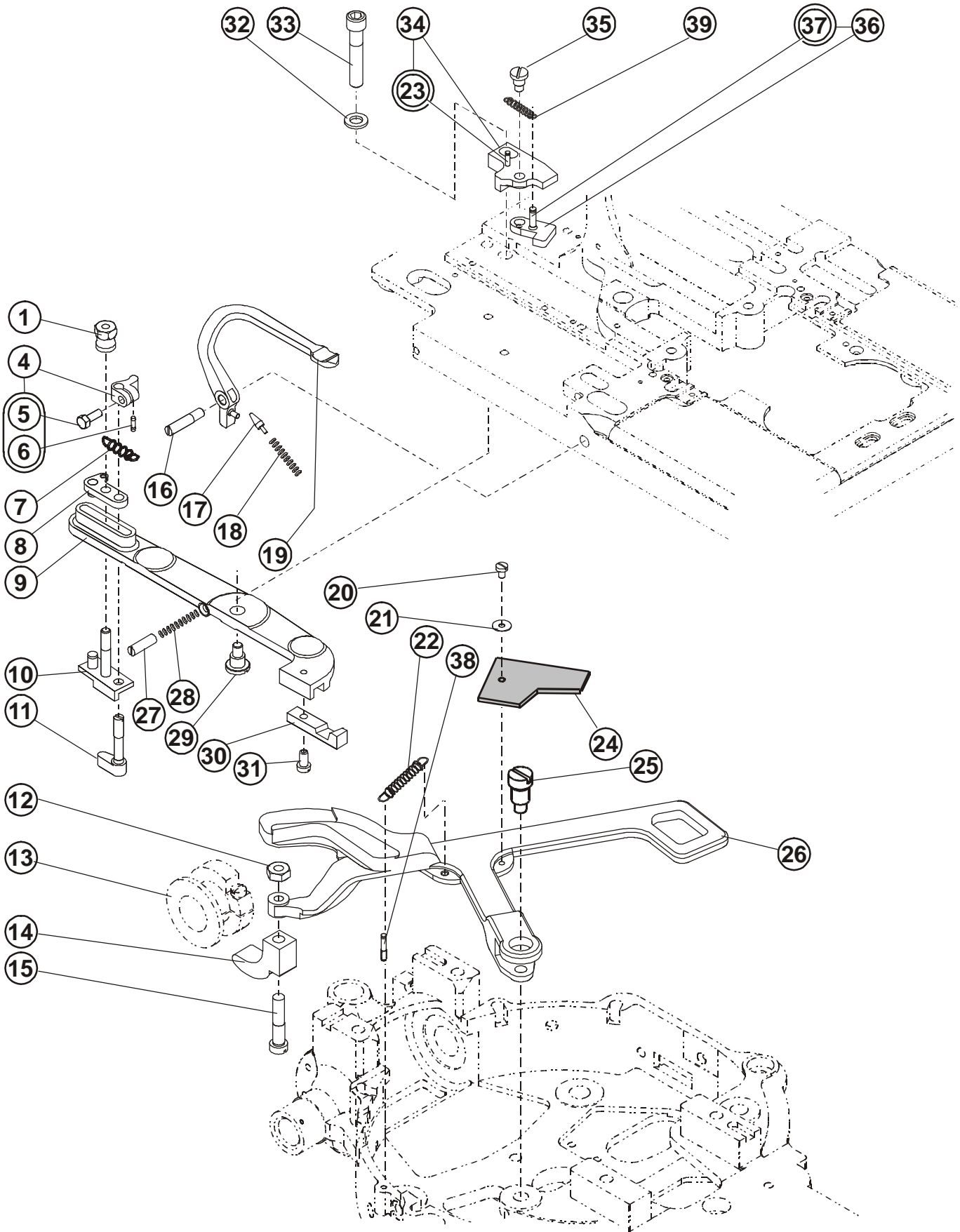

Released 09/2007

E-mail: service@amfreece.cz; parts@amfreece.cz ; website: www.amfreece.com
Phones: +420 582 309 146 (Service), +420 582 309 286 (Spare Parts) ; Fax: +420 582 360 606

STARTING LEVER AND SWITCH LEVER ASSEMBLY

DET	PART NUMBER	DESCRIPTION	QTY.
01	10.2008.0.000	Nut	1
02			
03			
04	10.2073.0.000	Latch Assembly	1
05	01.2386.0.000	Screw	(1)
06	01.6135.0.000	Pin	(1)
07	01.5473.0.000	Spring	1
08	10.2072.0.000	Plate	1
09	10.2012.0.000	Switch Lever	1
10	10.2070.1.000	Block	1
11	10.2071.0.000	Lever	1
12	01.3007.0.000	Nut	1
13	See Page 3-6	Shifter Spool Assembly	—
14	10.3031.0.000	Shifter Shoe	1
15	01.2032.1.000	Screw	1
16	10.2014.0.000	Pivot Screw	1
17	10.2015.0.000	Plunger	1
18	01.5020.0.000	Spring	1
19	14.2013.0.000	Starting Lever	1
20	01.2004.0.000	Screw	1
21	08.6850.4.000	Washer	1
22	01.5055.0.000	Spring	1
23	17.0031.1.401	Pin	1
24	17.0094.5.309	Felt Pad	1
25	10.3032.1.000	Screw	1
26	10.3029.1.000	Shifting Lever	1
27	01.2071.0.000	Screw	1
28	01.5019.0.000	Spring	1
29	10.2011.0.000	Pivot Screw	1
30	12.2010.0.000	Trip	1
31	01.2041.0.000	Screw	1
32	01.4522.0.000	Washer	1
33	01.1147.0.002	Screw	1
34	10.1180.0.000	Block	1
35	01.1100.0.000	Shoulder Screw	1
36	10.1181.0.000	Latch Assembly	1
37	01.6982.0.002	Pin	
38	12.1015.0.001	Pin	
39	01.5048.0.000	Spring	

Revised 04/2009

E-mail: service@amfreece.cz; parts@amfreece.cz ; website: www.amfreece.com

Phones: +420 582 309 146 (Service), +420 582 309 286 (Spare Parts) ; Fax: +420 582 360 606

COMBINATION LATERAL LEVER

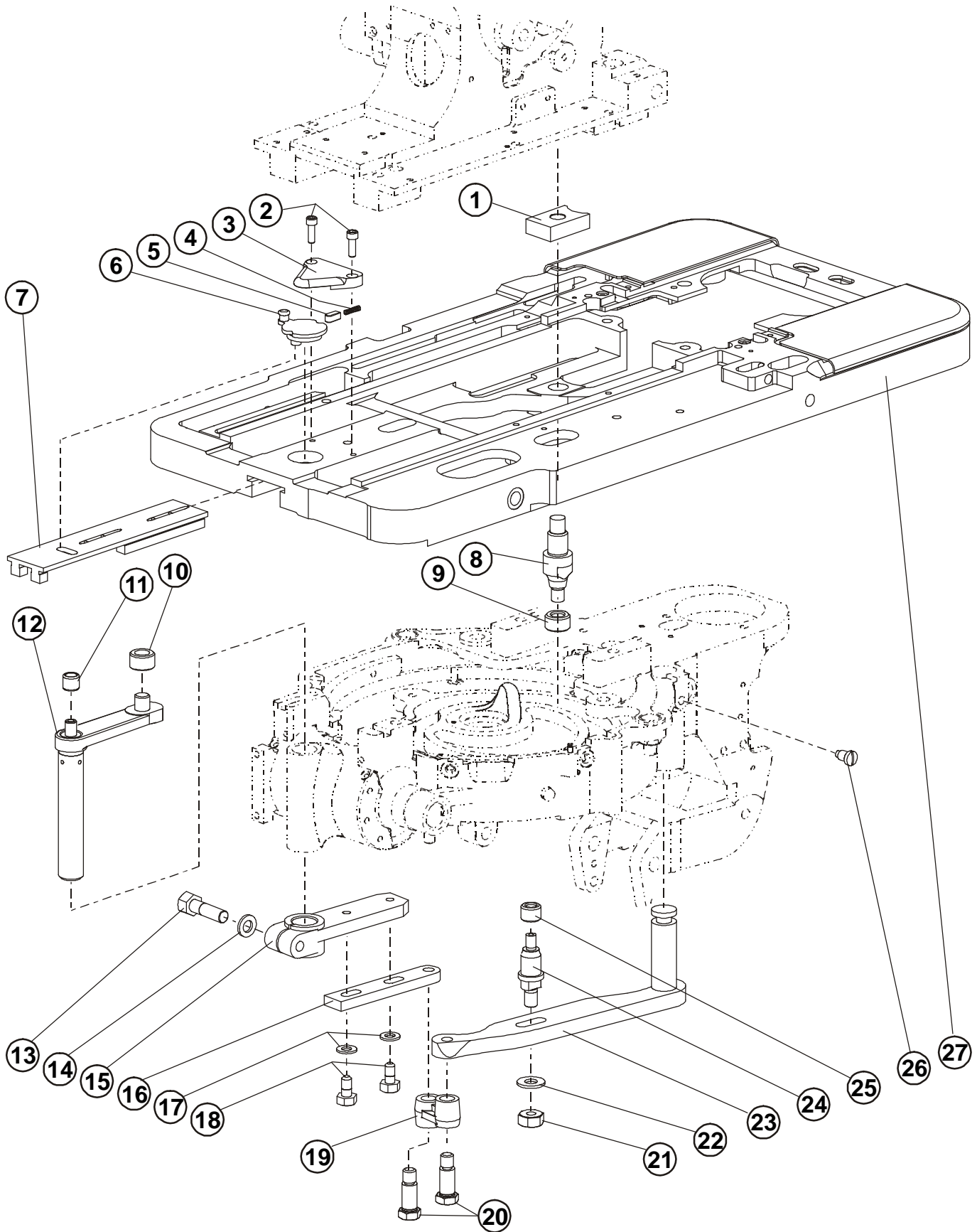

Released 09/2007

E-mail: service@amfreece.cz; parts@amfreece.cz ; website: www.amfreece.com
Phones: +420 582 309 146 (Service), +420 582 309 286 (Spare Parts) ; Fax: +420 582 360 606

COMBINATION LATERAL LEVER

DET	PART NUMBER	DESCRIPTION	QTY.
01	10.3033.0.020	Block	1
02	01.2412.0.000	Screw	2
03	10.2258.0.000	Cover	1
04	01.5172.0.000	Spring	1
05	10.2259.0.000	Plunger	1
06	10.2257.0.000	Shifter	1
07	10.2260.0.001	Guide Plate*7mm	1
	10.2260.0.200	Guide Plate	
	10.2260.0.217	(CB-RL only)	
	10.2260.0.167	(VA-XL only)	
08	10.2006.2.000	Bedplate Stud	1
09	10.2007.0.000	Roll	1
10	01.7043.0.000	Roll	1
11	01.7023.0.000	Roll	1
12	10.3034.0.258	Upper Lateral Lever* AF	1
13	01.2016.0.000	Screw	1
14	01.4522.0.000	Washer	1
15	10.3019.1.006	Lower Lateral Lever* AF	1
16	10.3300.0.006	Lower Lateral Extension	1
17	01.4063.0.000	Washer	2
18	01.2085.0.000	Screw	2
19	10.3302.0.000	Link	1
20	10.3301.1.006	Screw	2
21	01.3013.0.000	Nut	1
22	01.4005.0.000	Washer	1
23	10.3303.0.000	Combination Lever	1
24	10.3020.0.006	Stud AF	1
25	01.7004.0.000	Roll	1
26	01.2324.0.000	Screw	1
27	10.2001.4.250	Bedplate	1

Released 09/2007

E-mail: service@amfreece.cz; parts@amfreece.cz ; website: www.amfreece.com

Phones: +420 582 309 146 (Service), +420 582 309 286 (Spare Parts) ; Fax: +420 582 360 606

FLYBAR CONTROL & TURNING SECTORS & LEVERS

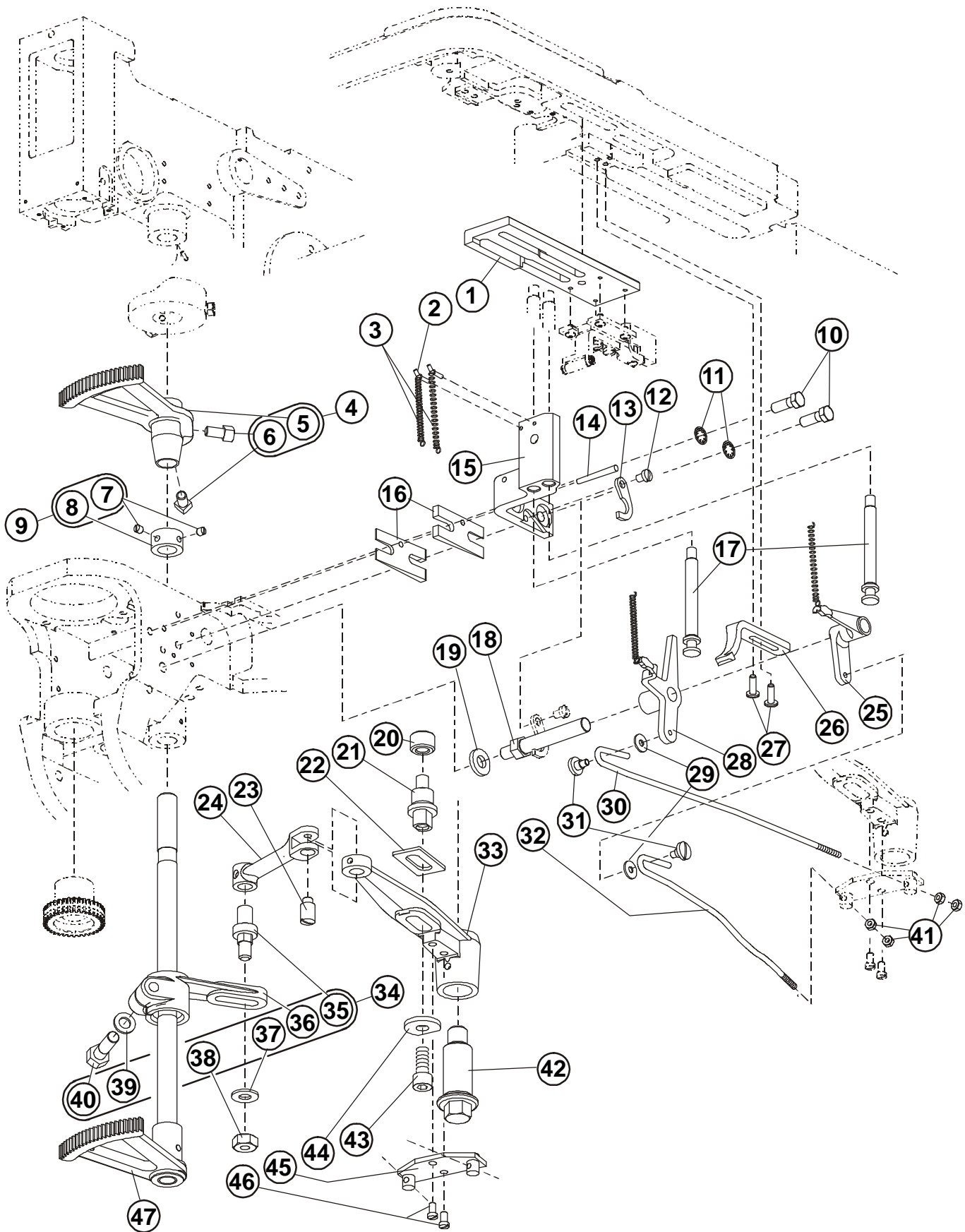

Released 09/2007

E-mail: service@amfreece.cz; parts@amfreece.cz ; website: www.amfreece.com
Phones: +420 582 309 146 (Service), +420 582 309 286 (Spare Parts) ; Fax: +420 582 360 606

FLYBAR CONTROL & TURNING SECTORS & LEVERS

DET	PART NUMBER	DESCRIPTION	QTY.
01	10.2255.2.150	Cam Plate * Flybar CA	1
	10.2255.3.200	Cam Plate * Flybar CB	
02	01.6839.0.001	Pin	2
03	01.5054.0.000	Spring	2
04	10.1075.1.051	Line*Uper Sector Lever Assembly	1
05	10.1075.1.000	Upper Sector	(1)
06	01.2014.0.000	Screw	(2)
07	10.2028.0.000	Screw	(2)
08	10.3010.0.000	Collar	(1)
09	10.3010.0.051	Line*Collar Assembly	1
10	01.2088.0.000	Screw	2
11	01.4046.0.000	Lockwasher	2
12	01.2006.0.000	Screw	1
13	10.3262.0.250	Latch	1
14	01.6031.0.000	Taper Pin	1
15	14.3251.1.000	Bracket	1
16	10.3250.1.000	Spacer	2
17	10.3252.1.000	Pin	2
18	01.1447.0.000	Stud AF	1
19	01.4701.0.000	Washer	1
20	10.3018.0.000	Roll*CA	1
21	14.3017.0.000	Sector Stud	1
22	14.3015.0.802	Plate	1
22	10.3026.0.000	Stud	1
24	10.3012.0.000	Link	1
25	10.3254.0.000	RH. Actuator Pin	1
26	10.2256.0.000	Bracket	1
27	01.2043.0.000	Screw	2
28	10.3253.0.000	Actuator	1
29	01.4472.0.000	Washer	2
30	11.3259.0.001	R.H. Wire Rod	1
31	01.1432.0.000	Screw	2
32	11.3259.0.002	L.H. Wire Rod	1
33	14.3015.0.000	Sector Lever	1
34	10.3011.0.051	LineShort Sector Lever Assembly	1
35	10.3013.0.000	Short Sector Lever Stud	(1)
36	10.3011.0.000	Short Sector Lever	(1)
37	01.4005.0.000	Washer	1
38	01.3013.0.000	Nut	(1)
39	01.4522.0.000	Washer	1
40	01.2016.0.000	Screw	(1)
41	08.6707.1.000	Nut	4
42	10.3016.0.000	Pivot Stud	4
43	01.1594.0.000	Screw	1
44	01.4154.0.000	Washer	1
45	10.3258.0.000	Wire Bracket	1
46	01.2079.0.000	Screw	2
47	10.3009.0.000	Lower Sector Assembly	1

Released 09/2007

E-mail: service@amfreece.cz; parts@amfreece.cz ; website: www.amfreece.com

Phones: +420 582 309 146 (Service), +420 582 309 286 (Spare Parts) ; Fax: +420 582 360 606

RACE

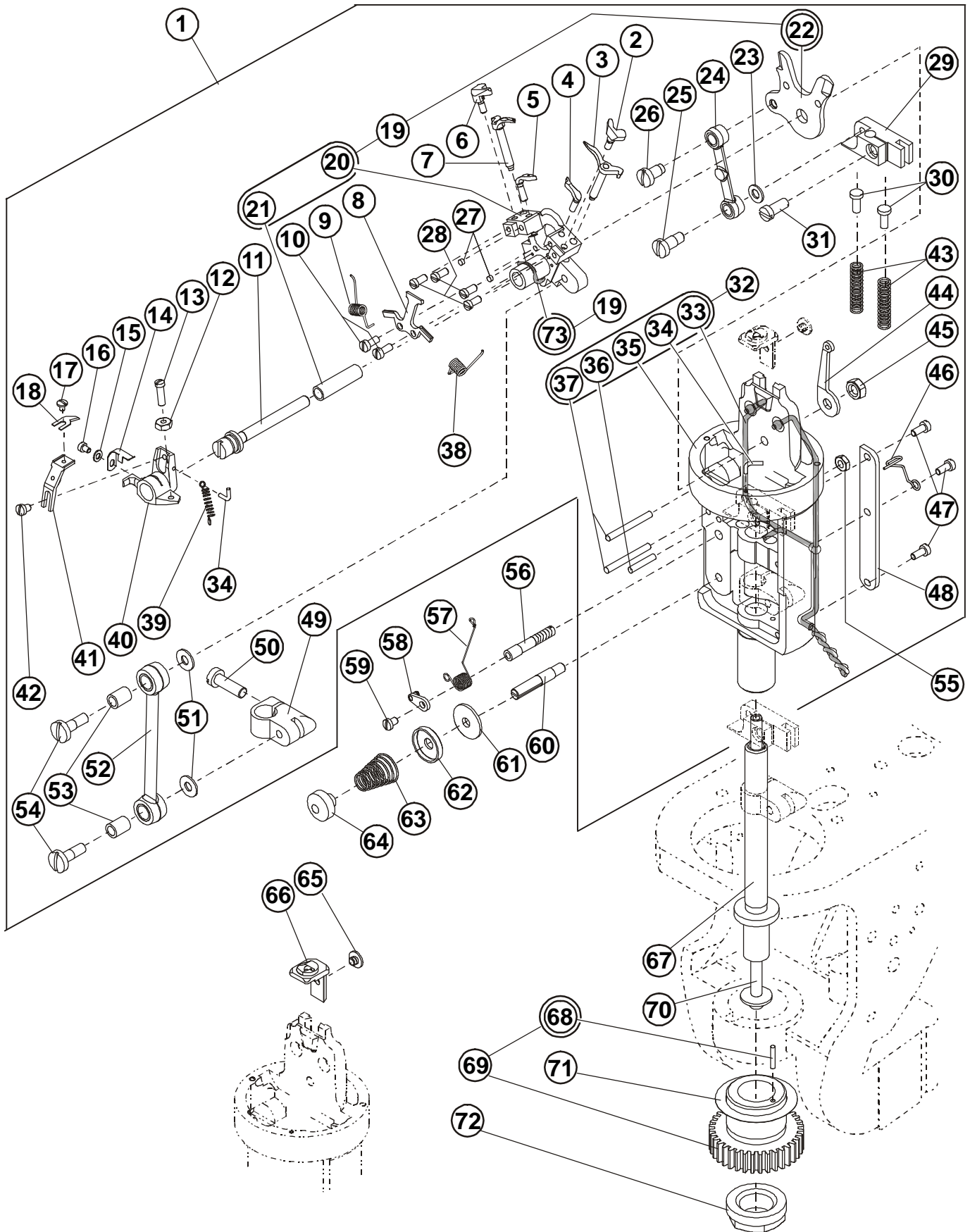

Released 09/2007

E-mail: service@amfreece.cz; parts@amfreece.cz ; website: www.amfreece.com
Phones: +420 582 309 146 (Service), +420 582 309 286 (Spare Parts) ; Fax: +420 582 360 606

RACE

DET	PART NUMBER	DESCRIPTION	QTY.
01	10.4001.0.150	Race Assembly * AF/CA 101	1
02	10.4006.0.000	R.H. Spreader Stop	(1)
03	14.4008.1.000	R.H. Spreader	(1)
04	10.4004.0.000	Blind Looper	(1)
05	14.4005.0.000	Eye Looper	(1)
06	10.4007.0.000	L.H. Spreader Stop	(1)
07	14.4009.1.000	L.H. Spreader	(1)
08	10.4010.2.000	Needle Guard	(1)
09	01.5620.0.000	L.H. Spring	(1)
10	01.2073.0.000	Screw	(2)
11	14.4201.0.000	Stud	(1)
12	01.3025.0.000	Nut	(1)
13	01.2361.0.000	Screw	(1)
14	10.4203.0.000	Retaining Spring	(1)
15	01.4015.0.000	Washer	(1)
16	01.2318.0.000	Screw	(1)
17	01.2667.0.000	Screw	(1)
18	14.1197.1.000	Trimmer Knife	(1)
19	10.9008.0.050	Looper Carrier/Spreader Wedge Assembly CB	(1)
20	10.4002.1.000	Looper Carrier	((1))
21	10.4003.0.000	Bushing	((1))
22	14.4011.0.200	Spreader Wedge S101	((1))
23	01.4012.0.000	Washer	(1)
24	14.4015.1.000	Spreader Link	(1)
25	10.4016.0.000	Screw	(1)
26	10.4017.0.000	Screw	(1)
27	10.4039.0.000	Felt Pad	(2)
28	01.2001.0.000	Screw	(4)
29	10.4018.0.000	Crosshead Spreader	(1)
30	10.4019.0.000	Pin	(2)
31	01.2059.0.000	Screw	(1)
32	14.4001.0.150	Race Assembly*AF-CA	(1)
33	07.0401.0.009	Wick	((1))
34	12.1010.0.012	Pin	(1+(1))
35	14.4001.0.904	Race	((1))
36	01.6013.0.000	Pin	((1))
37	01.6018.0.000	Pin	((2))
38	01.5619.0.000	R.H. Spring	(1)
39	01.5041.0.000	Spring	(1)
40	10.4202.0.000	Trimmer Holder	(1)
41	10.1198.1.000	Knife Holder	(1)
42	01.2081.0.000	Screw	(1)
43	01.5026.0.000	Spring	((2))
44	10.4035.0.000	Cord Guide	(1)
45	01.3005.0.000	Nut	(1)
46	05.1368.0.000	Guide Thread	(1)
47	01.2073.0.000	Screw	(3)
48	10.4026.0.000	Crosshead Guide	(1)
49	10.4021.0.000	Crosshead Looper	(1)
50	01.2024.0.000	Screw	(1)

Released 09/2007

E-mail: service@amfreece.cz; parts@amfreece.cz; website: www.amfreece.com

Phones: +420 582 309 146 (Service), +420 582 309 286 (Spare Parts); Fax: +420 582 360 606



RACE

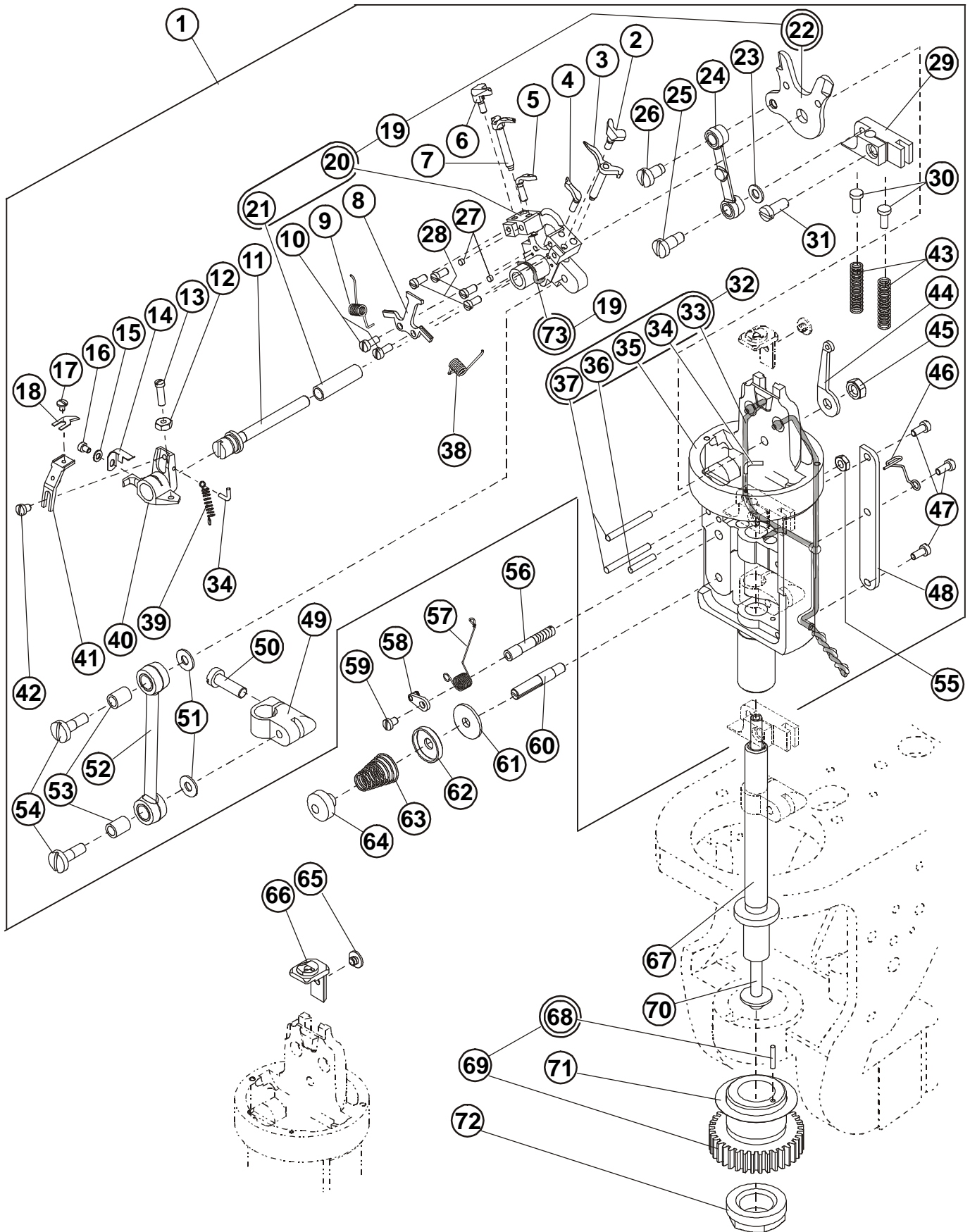

Released 09/2007

E-mail: service@amfreece.cz; parts@amfreece.cz ; website: www.amfreece.com
Phones: +420 582 309 146 (Service), +420 582 309 286 (Spare Parts) ; Fax: +420 582 360 606

RACE



DET	PART NUMBER	DESCRIPTION	QTY.
51	01.4013.0.000	Washer	(2)
52	14.4013.1.000	Looper Link	(1)
53	01.7022.0.000	Bushing	(2)
54	01.1006.0.000	Screw	(2)
55	01.3001.0.000	Nut	1
56	10.4037.0.000	Stud	1
57	01.5027.0.000	Check Spring	1
58	10.4036.0.000	Check.Spring Arm	1
59	01.2081.0.000	Screw	1
60	10.4029.0.000	Stud	1
61	10.4032.0.000	Thin Disc	1
62	10.4031.0.000	Heavy Disc	1
63	01.5028.0.000	Spring	1
64	10.4030.0.000	Nut	1
65	01.2056.0.000	Screw	1
66	10.4012.0.004	Throat /Plate* AF-CB/CA-R-RE	1
67	See Page 3-20	Spreader Spindle	—
68	01.6004.0.000	Pin	(1)
69	14.4025.0.901	Gear	1
70	See Page 3-20	Spindle Looper	—
71	01.4081.0.005	Shim (.005")	1
	01.4081.0.006	Shim (.006")	
	01.4081.0.008	Shim (.008")	
	01.4081.0.009	Shim (.009")	
	01.4081.0.010	Shim (.010")	
	01.4081.0.011	Shim (.011")	
	01.4081.0.012	Shim (.012")	
72	01.3018.0.000	Nut	1
73	07.0401.0.000	Felt	1

Released 09/2007

E-mail: service@amfreece.cz; parts@amfreece.cz ; website: www.amfreece.com

Phones: +420 582 309 146 (Service), +420 582 309 286 (Spare Parts) ; Fax: +420 582 360 606

THREAD TAKE UP & LOOPER DRIVE

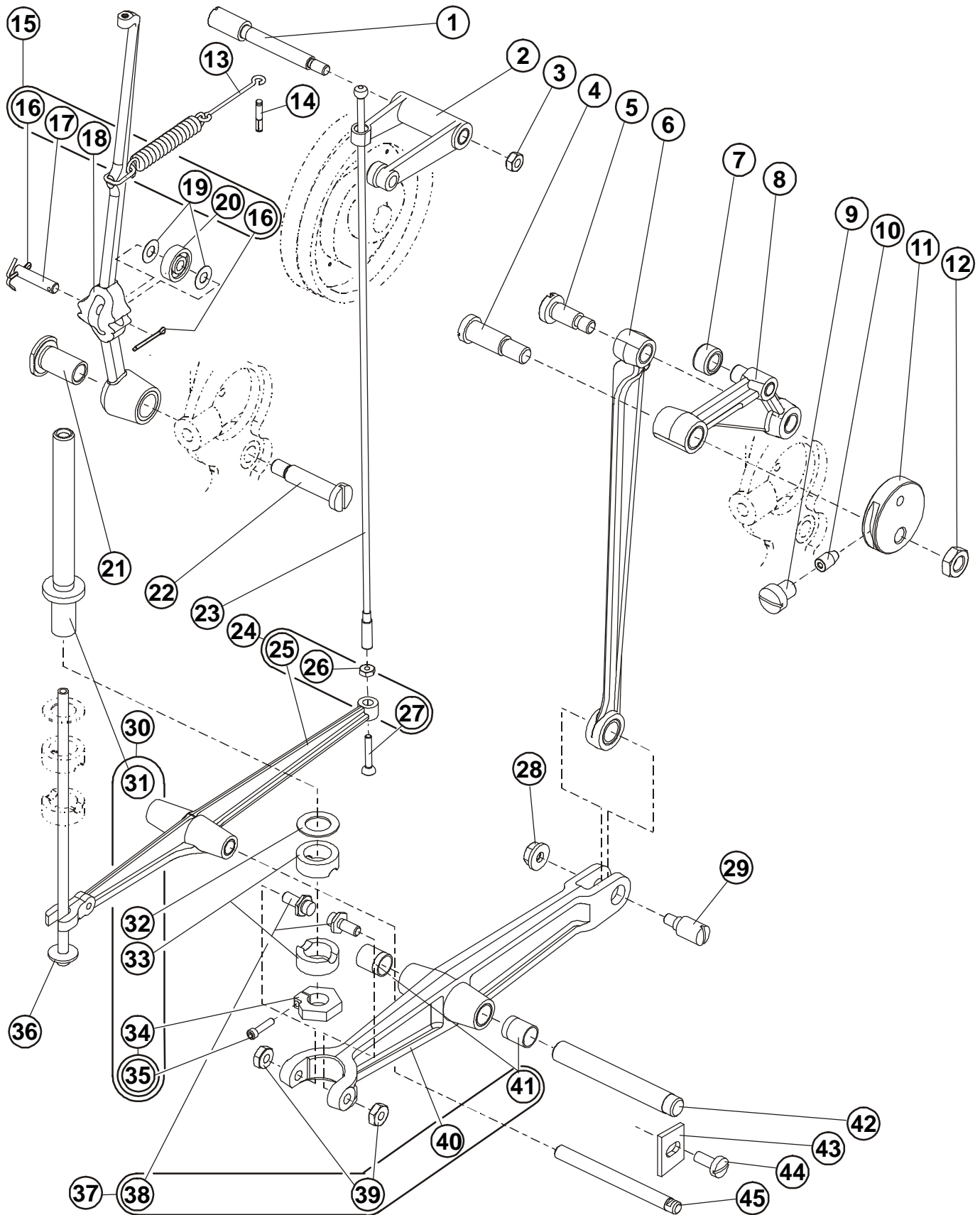

Released 09/2007

E-mail: service@amfreece.cz; parts@amfreece.cz ; website: www.amfreece.com
Phones: +420 582 309 146 (Service), +420 582 309 286 (Spare Parts) ; Fax: +420 582 360 606

THREAD TAKE UP & LOOPER DRIVE

DET	PART NUMBER	DESCRIPTION	QTY.
01	14.1059.0.000	Pivot Pin	1
02	14.1058.0.000	Cam Follower	1
03	01.3005.0.000	Nut	1
04	01.1151.0.000	Screw	1
05	10.1066.2.000	Shoulder Screw	1
06	14.1067.0.000	Looper Link	1
07	10.1122.0.998	Roll (No.1) 12,710	1
	10.1122.0.999	Roll (No.2) 12,705	
	10.1122.0.997	Roll 12,954 Oversize	
08	14.1064.2.000	Looper Cam Follower Assembly	1
09	01.2063.0.000	Screw	1
10	10.1062.0.000	Jam Plug	1
11	14.1026.0.000	Core Disc	1
12	01.3400.0.000	Nut	1
13	01.5005.0.001	Spring Assembly	1
14	17.0031.1.401	Pin	1
15	14.1236.0.000	Take-Up Lever Assembly	1
16	10.1053.0.000	Cotter Pin	(2)
17	13.1052.0.001	Stud	(1)
18	—————	Take-Up Lever	(1)
19	01.4751.0.000	Washer	(2)
20	01.7630.0.001	Ball Bearing	(1)
21	10.1054.0.000	Pivot Bushing	1
22	10.1055.0.000	Pivot Screw	1
23	10.1060.2.000	Spreader Link	1
24	14.3004.0.051	Spreader Rocker Assembly	1
25	14.3004.0.000	Spreader Rocker	(1)
26	01.3025.0.000	Nut	(1)
27	10.1061.1.000	Bolt Tip	(1)
28	01.3010.0.000	Nut	1
29	10.3008.0.000	Screw	1
30	14.4022.0.051	Line Spindle Looper Assembly	1
31	14.4022.0.000	Spindle – Looper	(1)
32	01.4010.0.000	Washer	(1)
33	10.4024.0.000	Bearing Ring	(1)
34	14.4023.0.000	Adjustable –Collar	(1)
35	01.2419.0.001	Screw	((1))
36	10.4020.0.000	Spreader Spindle	1
37	14.3006.0.201	Looper Rocker Assembly *CB	1
38	10.3007.0.000	Bearing	(2)
39	01.3020.0.000	Nut	(2)
40	10.3006.0.090	Lever	(1)
41	01.7309.0.901	Bearing	(2)
42	14.3005.0.000	Pivot Pin	1
43	10.3002.0.000	Locking Plate	1
44	01.2041.0.000	Screw	1
45	14.3003.0.000	Pivot Pin	1

Released 09/2007

E-mail: service@amfreece.cz; parts@amfreece.cz; website: www.amfreece.com

Phones: +420 582 309 146 (Service), +420 582 309 286 (Spare Parts); Fax: +420 582 360 606

UPPER THREAD TRIMMER

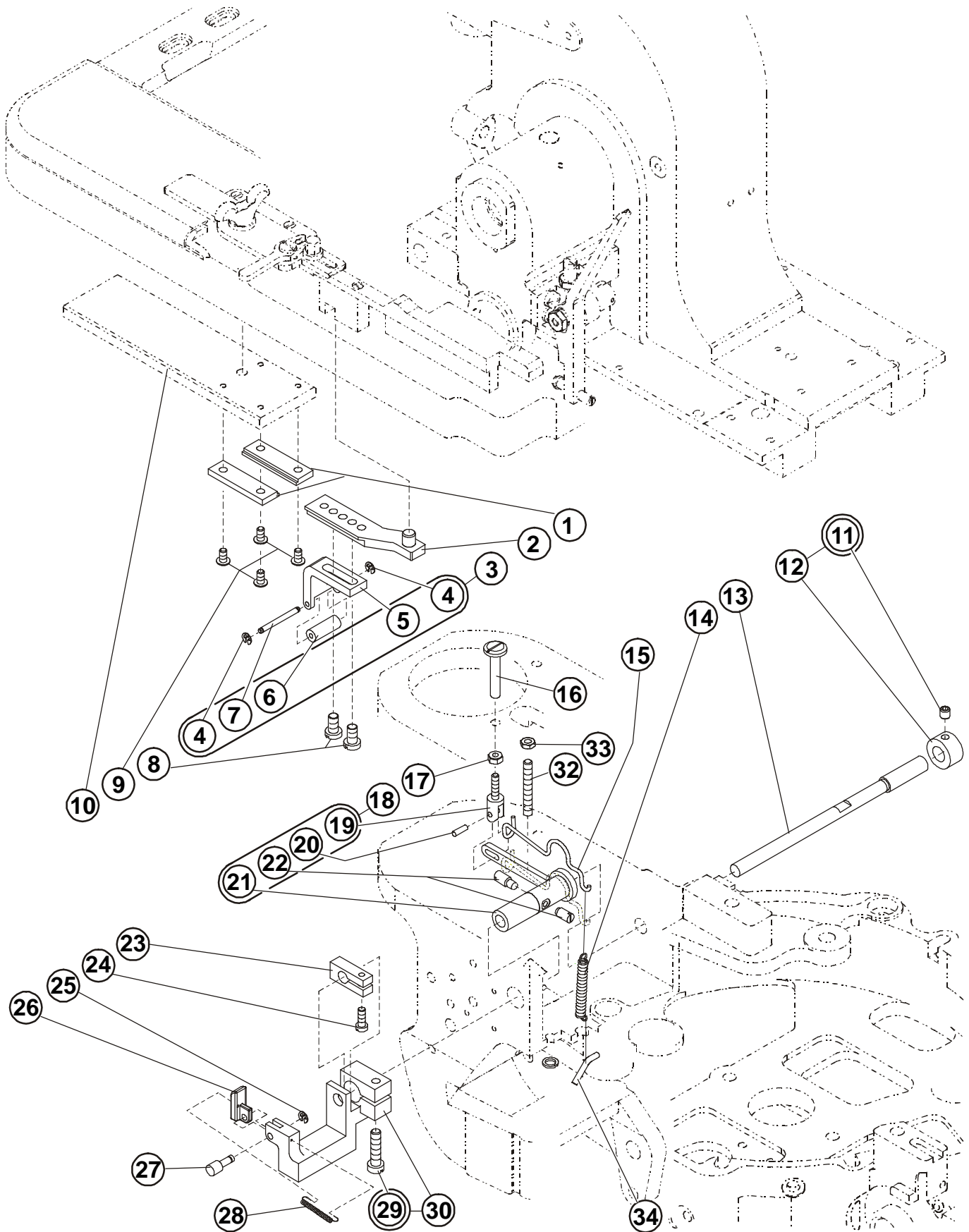

Released 09/2007

E-mail: service@amfreece.cz; parts@amfreece.cz; website: www.amfreece.com
Phones: +420 582 309 146 (Service), +420 582 309 286 (Spare Parts); Fax: +420 582 360 606

UPPER THREAD TRIMMER

DET	PART NUMBER	DESCRIPTION	QTY.
01	10.2264.0.000	Rail	2
02	10.2263.0.000	Link	1
03	14.2069.0.050	Trip Bracket Assembly	1
04	01.6280.0.000	Retaining Ring	(2)
05	14.2069.0.000	Trip Bracket	(1)
06	14.2069.0.802	Trip Roller	(1)
07	01.6612.0.000	Pin	(1)
08	01.2175.0.000	Screw	2
09	01.2131.0.000	Screw	4
10	See Page 3-14	Cam Plate	—
11	01.7435.1.000	Collar+Screw	1
12	—————	Screw	(1)
13	14.5019.0.000	Upper Thread Trimmer Shaft	1
14	01.5134.0.000	Spring	1
15	10.3086.0.000	Spring Hook Lever*AF	1
16	10.3206.0.000	Actuator	(1)
17	01.3016.0.000	Nut	(1)
18	14.3085.1.050	Trimming Lever Assembly* AF	1
19	10.3205.0.000	Clevis	(1)
20	01.6010.0.000	Pin	(1)
21	—————	Trimming Lever Assembly	(1)
22	10.3203.0.000	Stop Block	(2)
23	14.3088.0.000	Clamp	1
24	01.2144.0.000	Screw	1
25	01.6368.0.000	Retaining Ring	1
26	10.3089.2.000	Latch	1
27	01.6528.0.000	Pivot	1
28	01.5433.0.000	Spring	1
29	01.2171.0.000	Screw	(1)
30	14.3087.0.000	Actuator	1
31			
32	01.2077.0.000	Screw	1
33	01.3005.0.000	Nut	1

Released 09/2007

E-mail: service@amfreece.cz; parts@amfreece.cz ; website: www.amfreece.com

Phones: +420 582 309 146 (Service), +420 582 309 286 (Spare Parts) ; Fax: +420 582 360 606

CLAMP YOKE ASSEMBLY

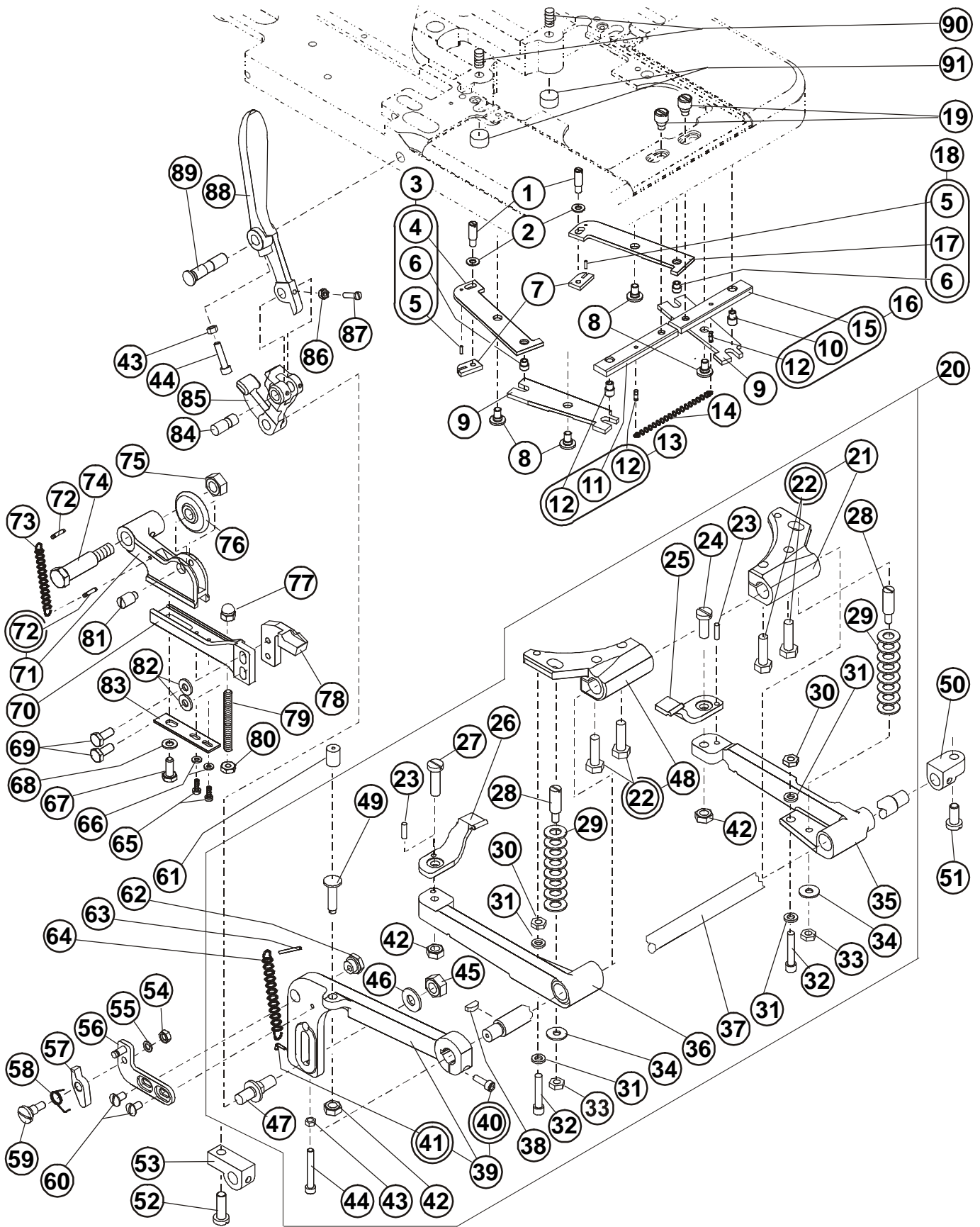

Released 09/2007

E-mail: service@amfreece.cz; parts@amfreece.cz ; website: www.amfreece.com
Phones: +420 582 309 146 (Service), +420 582 309 286 (Spare Parts) ; Fax: +420 582 360 606

CLAMP YOKE ASSEMBLY

DET	PART NUMBER	DESCRIPTION	QTY.
01	10.2042.0.000	Screw	2
02	01.4067.0.000	Washer	2
03	10.2039.0.000	L.H. Rear Link Assembly	1
04	14.2039.0.801	L.H. Rear Link	(1)
05	01.6555.0.000	Pin	(2)
06	01.6075.0.000	Pin	(2)
07	10.2041.0.000	Locking Plate	2
08	01.1021.0.000	Screw	4
09	10.2036.0.000	Front Link	2
10	01.6074.0.000	Pin	(2)
11	10.2033.0.801	R.H. Slide Clamp	(1)
12	01.6839.0.001	Pin	2
13	10.2034.0.000	L.H. Clamp Slide Assembly	1
14	01.5023.0.000	Spring	1
15	10.2034.0.801	L.H. Slide Clamp	(1)
16	10.2033.0.000	R.H. Clamp Slide Assembly	1
17	14.2040.0.901	R.H. Rear Link	(1)
18	14.2040.0.000	R.H. Rear Link Assembly	1
19	01.1020.1.000	Screw	2
20	14.2026.0.050	Compressing Clamp Assembly	1
21	14.2026.0.002	Clamp Arm Toggle	(1)
22	01.1686.0.401	Screw	((4))
23	—	Pin	(2)
24	01.2539.0.001	Screw	(1)
25	10.2027.1.000	R.H. Pull Down	(1)
26	10.2028.1.000	L.H. Pull Down	(1)
27	01.2539.0.000	Screw	(1)
28	01.1238.0.000	Stud	(2)
29	01.4121.0.000	Washer	(4)
30	01.3404.0.000	Nut	(2)+(2)
31	01.4042.0.000	Washer	(2)+(2)
32	03.6000.0.216	Screw	(2)
34	01.4559.0.000	Washer	(2)
35	14.2026.0.005	LH. Clamp Yoke	(1)
36	14.2026.0.006	R.H. Clamp Yoke	(1)
37	14.2024.0.000	Shaft	(1)
38	01.8404.0.001	Key	(1)
39	14.2023.1.000	Toggle Bracket	(1)
40	01.2412.0.000	Screw	((1))
41	01.6006.0.000	Pin	((1))
42	01.3007.0.000	Nut	(3)
43	01.3001.0.000	Nut	(2)
44	01.2482.0.000	Screw	(2)
45	01.3013.0.000	Nut	(1)
46	01.4005.0.000	Washer	(1)
47	10.2024.0.000	Stud	(1)
48	14.2026.0.003	Clamp Arm Toggle	(1)
49	13.2086.0.000	Adjusting Screw	(1)
50	10.2025.0.017	Clamp Yoke Bearing* AF	1

Released 09/2007

E-mail: service@amfreece.cz; parts@amfreece.cz; website: www.amfreece.com

Phones: +420 582 309 146 (Service), +420 582 309 286 (Spare Parts); Fax: +420 582 360 606



CLAMP YOKE ASSEMBLY

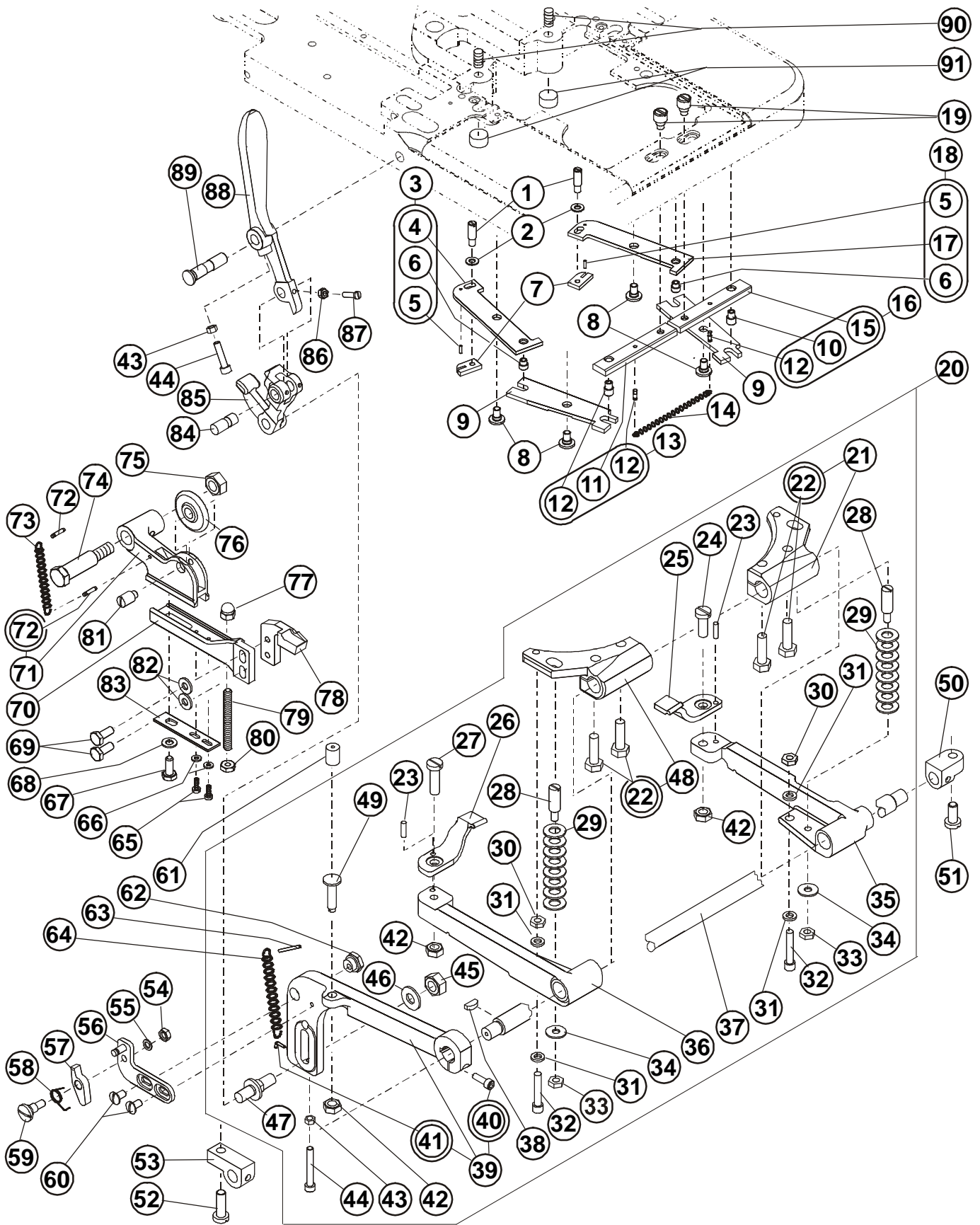

Released 09/2007

E-mail: service@amfreece.cz; parts@amfreece.cz ; website: www.amfreece.com
Phones: +420 582 309 146 (Service), +420 582 309 286 (Spare Parts) ; Fax: +420 582 360 606

CLAMP YOKE ASSEMBLY



DET	PART NUMBER	DESCRIPTION	QTY.
51	01.2046.0.000	Screw	1
52	01.2046.0.000	Screw	1
53	10.2025.0.000	Clamp Yoke Bearing	1
54	01.3005.0.000	Nut	1
56	10.2074.0.000	Bracket	1
57	10.2075.0.000	Latch	1
58	01.5475.0.000	Spring	1
59	01.1457.0.000	Screw	1
60	01.2344.0.000	Screw	2
61	13.2087.1.000	Bumper	1
62	13.2088.0.000	Eccentric Nut	1
63	12.1010.0.220	Pin	1
64	01.5013.0.000	Spring	1
65	01.2241.0.002	Screw	2
66	08.6850.7.001	Washer	2
67	01.1601.0.001	Screw	2
68	01.4063.0.000	Washer	1
69	01.1601.0.007	Screw	2
70	13.3022.1.023	Extension	1
71	13.3023.0.000	Clamping Lever Assembly	1
72	01.6014.0.000	Pin	1+(1)
73	01.5015.0.000	Spring	1
74	01.1076.0.000	V Bolt	1
75	01.3414.0.000	Nut	1
76	10.3025.0.000	Roller	1
77	05.0144.0.000	Nut Plastik Acorn	1
78	13.3131.0.000	Tip	1
79	01.1649.0.004	Pivot Screw	1
80	01.3415.0.000	Nut	1
81	10.3026.0.000	Toggle Lever Stud	1
82	01.4445.0.000	Washer	2
83	13.3094.2.000	Slide	1
84	10.2022.0.000	Pivot Stud	1
85	13.2021.0.023	Toggle Lever	1
86	01.3016.0.000	Nut	1
87	01.2045.0.000	Screw	1
88	10.2019.0.000	Clamping Lever	1
89	10.2020.0.000	Pivot Pin	1
90	01.2981.0.001	Screw	2
91	14.2009.0.000	Support Button	2

Revised 04/2013

E-mail: service@amfreece.cz; parts@amfreece.cz ; website: www.amfreece.com

Phones: +420 582 309 146 (Service), +420 582 309 286 (Spare Parts) ; Fax: +420 582 360 606

CUTTING LEVER ASSEMBLY

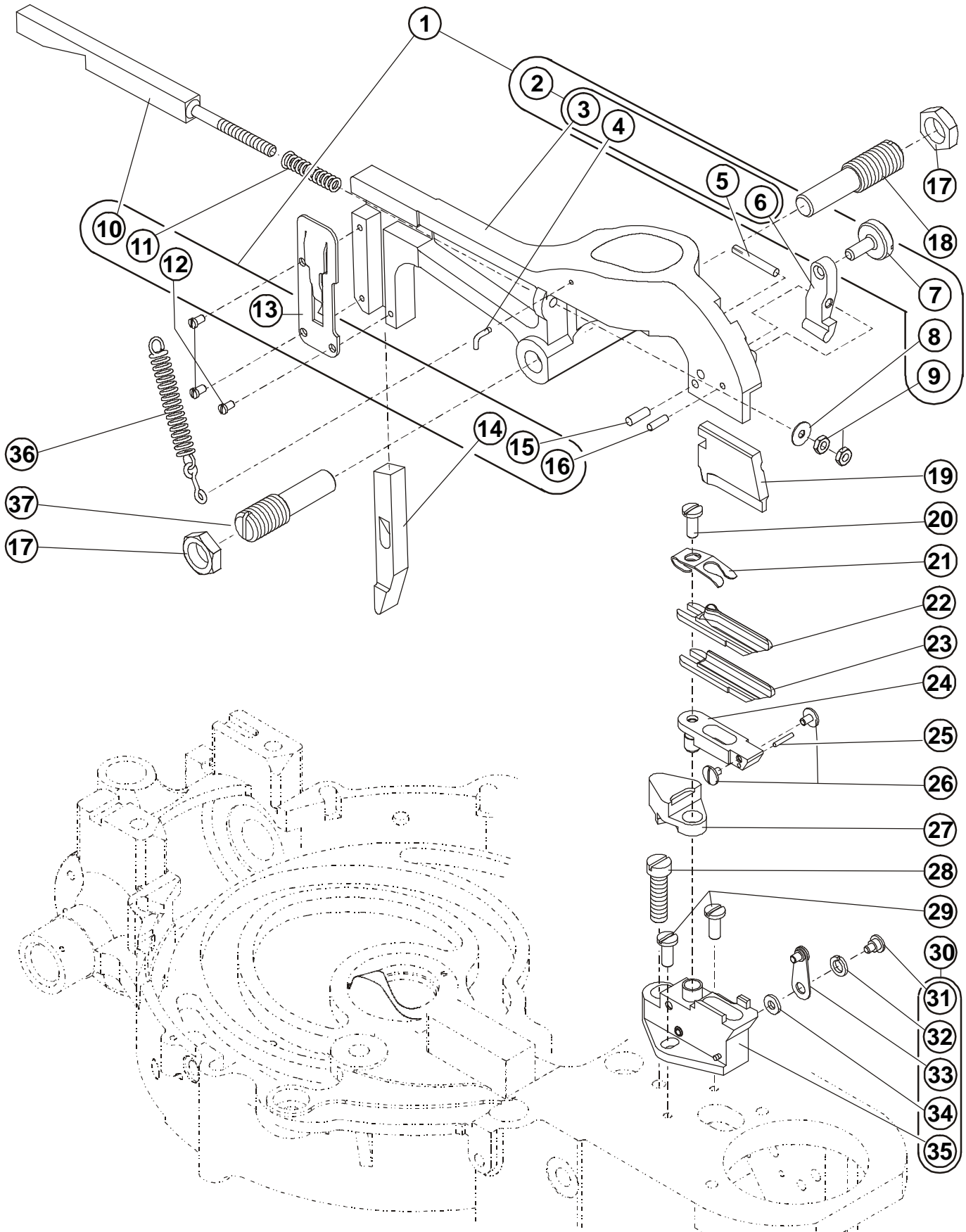

Released 09/2007

E-mail: service@amfreece.cz; parts@amfreece.cz ; website: www.amfreece.com
Phones: +420 582 309 146 (Service), +420 582 309 286 (Spare Parts) ; Fax: +420 582 360 606

CUTTING LEVER ASSEMBLY

DET	PART NUMBER	DESCRIPTION	QTY.
01	14.8888.2.287	Cutting Lever Assembly	1
02	10.1068.1.050	Cutting Lever Assembly	((1))
03	10.1068.0.901	Cutting Lever* Machined	(1)
04	01.6006.0.000	Anchor	((1))
05	01.6837.0.000	Pin	((1))
06	10.1163.0.000	Clamp	((1))
07	01.1257.0.000	Screw	1
08	01.4001.0.000	Washer	(1)
09	01.3001.0.000	Nut	(2)
10	10.1072.0.000	Pressure Bar	(1)
11	01.5061.0.000	Spring	(1)
12	01.2013.0.000	Screw	(3)
13	10.1073.1.000	Cover Plate	(1)
14	10.1071.1.023	Cutting Cam Follower	(1)
15	01.6026.0.000	Pin	((1))
16	01.3010.0.000	Pin	((1))
17	01.3006.0.000	Nut	(2)
18	10.1074.0.000	L.H. Pivot Stud	(1)
19	10.1069.0.001	Cutting Steel* 1/2" Eye	1
	See Page 3-51	Cutting Steel* 3/4" Eye Cutting Steel* 1" Eye Cutting Steel* 1-1/4" Eye	—
	01.2039.0.000	Screw	1
	10.3074.0.011	Cloth Lifting Spring*CB	1
22	10.3072.0.024	Knife	1
23	See Page 3-21	Knife	1
24	10.3071.1.250	Knife Pad	1
25	01.6036.0.000	Pin	1
26	01.2102.0.000	Screw	2
27	10.3067.4.254	Spreading Block	1
28	01.2038.0.000	Screw	1
29	01.2039.0.000	Screw	2
30	10.3070.0.251	Knife Holder Assembly	1
31	01.1130.0.000	Screw	(1)
32	01.4003.0.000	Washer	(1)
33	01.5173.0.000	Spring	(1)
34	08.6850.7.001	Washer	(1)
35	10.3070.0.250	Knife Holder	(1)
36	01.5006.0.001	Spring	1
37	10.1074.0.250	R.H. Pivot Stud	1

Released 09/2007

E-mail: service@amfreece.cz; parts@amfreece.cz ; website: www.amfreece.com

Phones: +420 582 309 146 (Service), +420 582 309 286 (Spare Parts) ; Fax: +420 582 360 606

LENGTH GAUGE

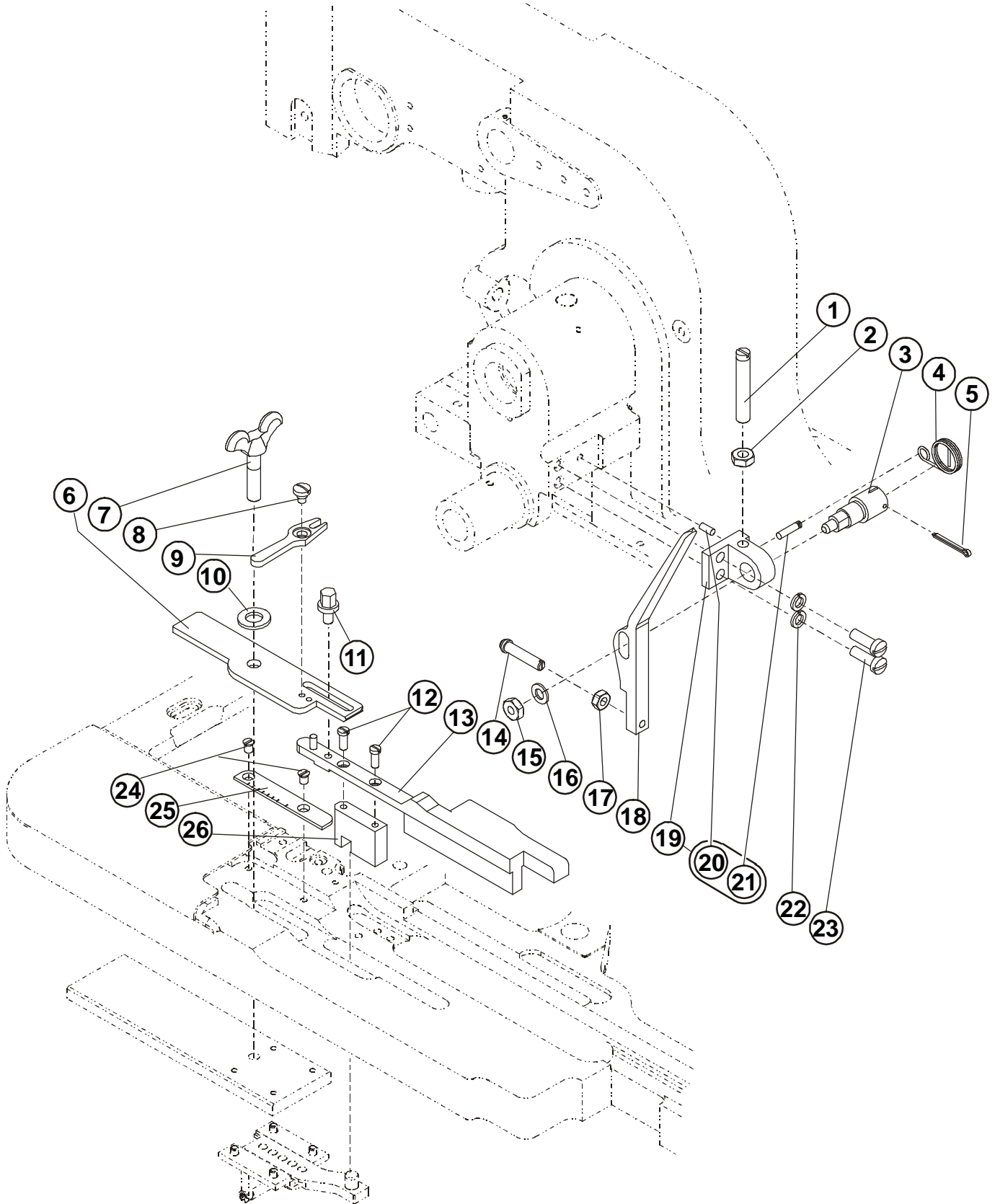

Released 09/2007

E-mail: service@amfreece.cz; parts@amfreece.cz ; website: www.amfreece.com
Phones: +420 582 309 146 (Service), +420 582 309 286 (Spare Parts) ; Fax: +420 582 360 606

LENGTH GAUGE

DET	PART NUMBER	DESCRIPTION	QTY.
01	01.2066.0.000	Screw	1
04	01.5088.0.000	Spring	1
03	10.1125.2.000	Stud	1
05	10.1053.0.000	Cotter Pin	1
06	10.2251.0.001	Lenght Plate* 7mm	1
07	14.2254.1.901	Wing Bolt Assembly	1
08	10.2252.0.000	Screw	1
09	10.2253.0.000	Tack Lever	1
10	01.4063.0.000	Washer	1
11	10.2250.1.000	Nut	1
02	01.3011.0.000	Nut	1
12	01.2084.0.000	Screw	2
13	10.2018.1.250	Lenght Gauge* Regular	1
14	10.1126.0.000	Screw	1
15	01.3020.0.000	Nut	1
16	08.6852.6.000	Washer	1
17	01.3005.0.000	Nut	1
18	10.1124.0.000	Trip Lever	1
19	10.1127.3.000	Trip Lever Bracket	1
20	01.6020.0.000	Pin	(1)
21	01.6833.0.002	Spring Anchor	(1)
22	01.4003.0.000	Washer	2
23	01.2041.0.000	Screw	2
24	01.2075.0.001	Screw	2
25	10.2261.0.030	Lenght Gauge* Inches	1
	10.2261.0.040	Lenght Gauge* Metric	
	14.2261.0.000	Lenght Gauge* ST.CT	
26	10.2262.0.000	Block	1

Released 09/2007

E-mail: service@amfreece.cz; parts@amfreece.cz ; website: www.amfreece.com

Phones: +420 582 309 146 (Service), +420 582 309 286 (Spare Parts) ; Fax: +420 582 360 606

STITCH FEED

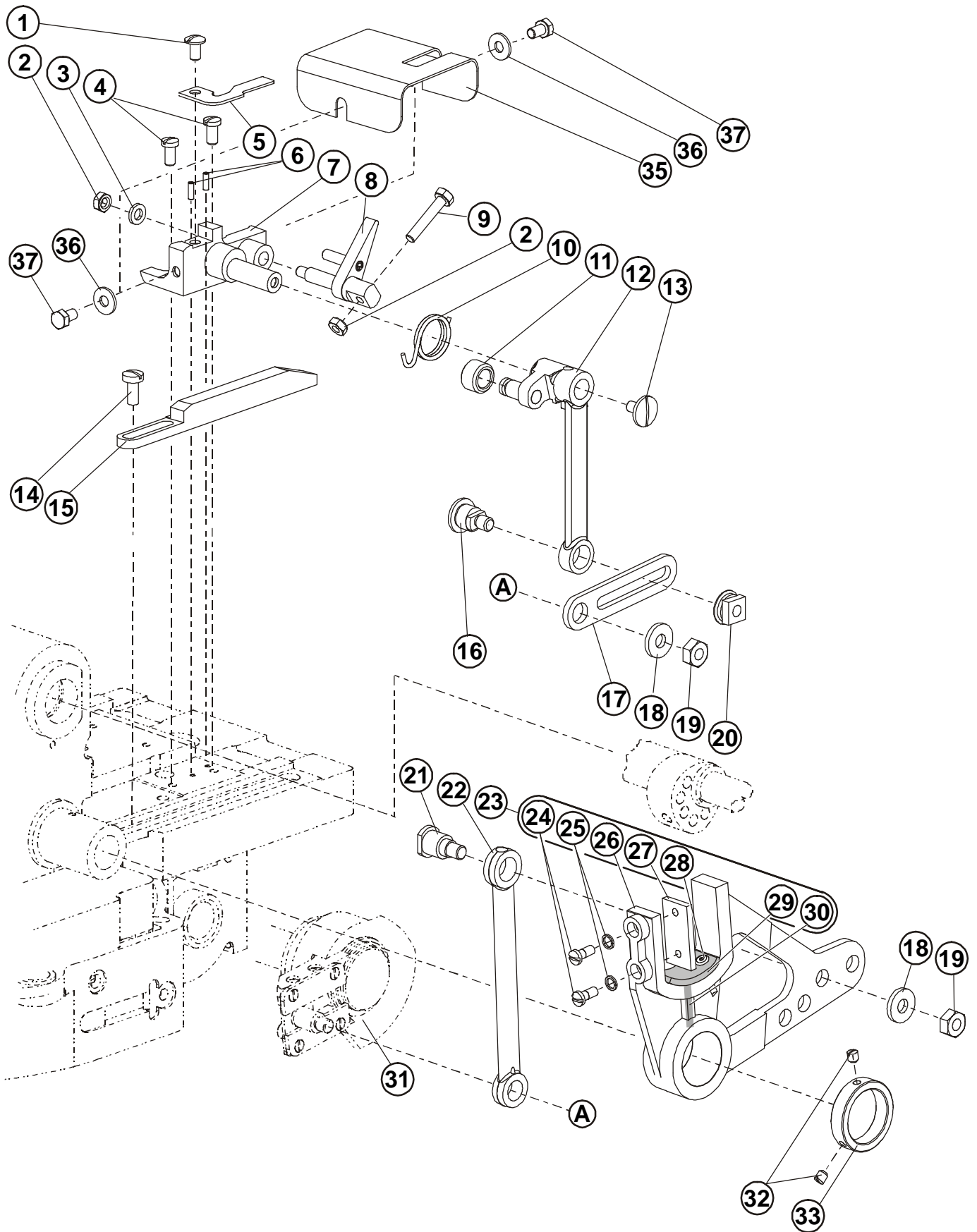

Released 09/2007

E-mail: service@amfreece.cz; parts@amfreece.cz ; website: www.amfreece.com
Phones: +420 582 309 146 (Service), +420 582 309 286 (Spare Parts) ; Fax: +420 582 360 606

STITCH FEED

DET	PART NUMBER	DESCRIPTION	QTY.
01	01.2344.0.000	Screw	1
02	01.3005.0.000	Nut	2
03	01.4042.0.000	Washer	1
04	01.2130.0.000	Screw	2
05	01.5447.0.000	Spring	1
06	01.6428.0.000	Pin	2
07	10.1167.1.000	Shifter Block	1
08	10.1169.0.000	Shifter	1
09	01.2543.0.000	Screw	1
10	01.5448.0.000	Spring	1
11	10.2007.0.350	Roll	1
12	10.1168.0.000	Link	1
13	01.2146.0.000	Screw	1
14	01.2041.0.000	Screw	1
15	10.2061.0.000	Stitch Taske-Out Wedge	1
16	01.1028.0.000	Stud	1
17	10.3081.0.000	Arm	1
18	01.4503.0.000	Washer	2
19	01.3042.0.000	Nut	2
20	01.3019.0.000	Nut	1
21	01.1132.0.000	Screw	1
22	10.1109.3.000	Link	1
23	14.1108.0.050	Follower-Feed Cam Assembly	1
24	01.2022.0.000	Screw	(2)
25	01.4019.0.000	Spring Washer	(2)
26	14.1108.0.901	Feed Cam Follow	((1))
27	10.1107.0.801	Plate	(1)
28	12.4021.0.312	Rivet	(1)
29	14.1029.0.000	Feelt	(1)
30	07.0400.0.000	Wick	(1)
31	See Page 3-7	Feed Clutch Assembly	—
32	08.6400.5.305	Screw	(2)
33	01.7038.1.000	Collar	(1)
34			
35	10.1170.0.000	Stitch feed Cover	1
36	01.4052.0.000	Washer	2
37	01.2390.0.000	Screw	2

Released 09/2007

E-mail: service@amfreece.cz; parts@amfreece.cz; website: www.amfreece.com

Phones: +420 582 309 146 (Service), +420 582 309 286 (Spare Parts); Fax: +420 582 360 606

THREE FORK LEVER

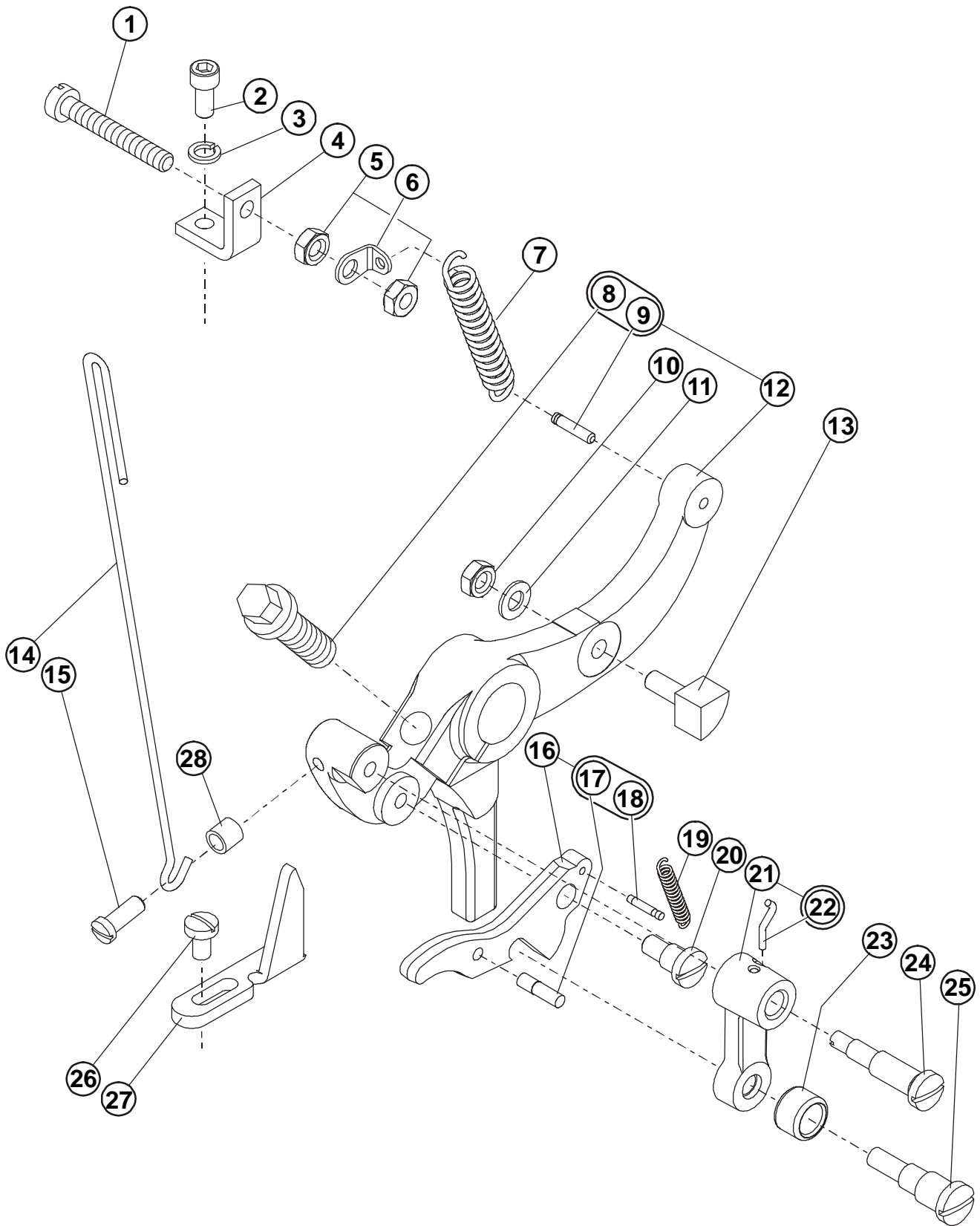

Released 09/2007

E-mail: service@amfreece.cz; parts@amfreece.cz ; website: www.amfreece.com
Phones: +420 582 309 146 (Service), +420 582 309 286 (Spare Parts) ; Fax: +420 582 360 606

THREE FORK LEVER

DET	PART NUMBER	DESCRIPTION	QTY.
01	08.6000.4.040	Screw	1
02	01.2412.0.000	Screw	1
03	01.4407.0.000	Lockwasher	1
04	14.1099.0.000	Spring Bracket	1
05	08.6700.4.000	Nut	2
06	14.5034.0.000	Cord Guide	1
07	01.5075.0.000	Spring	1
08	10.1114.1.000	Screw	(1)
09	12.1015.0.001	Anchor Pin	(1)
10	01.3005.0.000	Nut	1
11	01.4011.0.000	Washer	1
12	10.1113.0.000	Lever	1
13	10.1117.0.000	Dog	1
14	10.1083.0.000	Link	1
15	01.2321.0.000	Screw	1
16	10.1118.0.000	Lever Assembly	1
17	01.6166.0.000	Pin	(1)
18	01.6005.0.000	Anchor Pin	(1)
19	01.5014.0.000	Spring	1
20	10.1119.0.000	Screw	1
21	10.1120.0.000	Link	1
22	01.6030.0.000	Pin	(1)
23	10.1122.0.017	Rool	1
24	01.1095.0.000	Screw	1
25	10.1121.0.017	Stud	1
26	01.2042.0.000	Screw	1
27	10.2016.0.000	Bumper	1
28	10.1115.0.000	Spacer	1

Revised 06/2009

E-mail: service@amfreece.cz; parts@amfreece.cz ; website: www.amfreece.com

Phones: +420 582 309 146 (Service), +420 582 309 286 (Spare Parts) ; Fax: +420 582 360 606

ROCKING LEVER

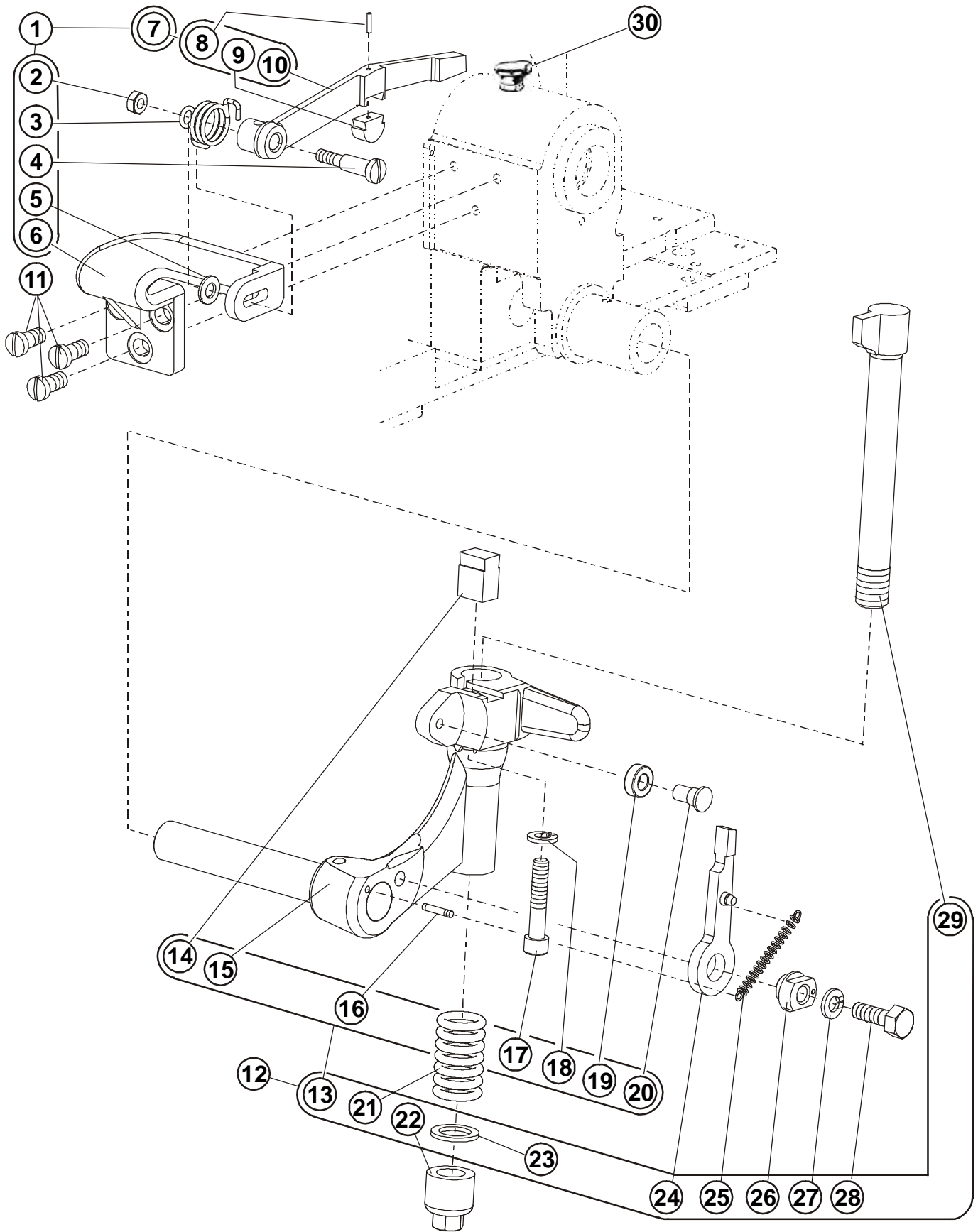

Released 09/2007

E-mail: service@amfreece.cz; parts@amfreece.cz; website: www.amfreece.com
Phones: +420 582 309 146 (Service), +420 582 309 286 (Spare Parts); Fax: +420 582 360 606

ROCKING LEVER

DET	PART NUMBER	DESCRIPTION	QTY.
01	14.1085.0.850	Fly Over Lever Assembly	1
02	01.3005.0.000	Nut	(1)
03	01.5007.0.000	Spring	(1)
04	10.1086.0.000	Screw	(1)
05	01.4002.0.000	Washer	(1)
06	10.1087.0.000	Bracket	(1)
07	14.1085.0.000	Flyover Lever Assembly	(1)
08	01.6638.0.000	Pin	((1))
09	14.1084.0.000	Wear Pad	((1))
10	14.1085.0.901	Flyover Lever	((1))
11	01.2017.0.000	Screw	1
12	10.1098.0.850	Rocking Lever Assembly	1
13	10.1098.2.050	Rocking Arm & Shaft Assembly	(1)
14	14.1102.0.000	Dog	((1))
15	—	Rocking Arm & Shaft	((1))
16	01.6014.0.000	Pin	((1))
17	01.1624.0.002	Screw	((1))
18	01.4004.0.000	Washer	((1))
19	01.7002.1.000	Roll	((1))
20	01.6350.1.000	Stud	((1))
21	01.5010.0.000	Spring	(1)
22	01.3436.0.000	Nut	(1)
23	01.4034.0.003	Washer	(1)
24	10.1100.0.000	Latch	(1)
25	01.5011.0.000	Spring	(1)
26	10.1101.0.000	Eccentric	(1)
27	01.4004.0.000	Washer	(1)
28	01.2020.0.000	Screw	(1)
29	10.1099.0.000	Bolt	(1)
30	10.1149.0.000	Oil Cup	1

Released 09/2007

E-mail: service@amfreece.cz; parts@amfreece.cz; website: www.amfreece.com

Phones: +420 582 309 146 (Service), +420 582 309 286 (Spare Parts); Fax: +420 582 360 606

STOP WHEEL & STITCH DRIVE ASSEMBLY

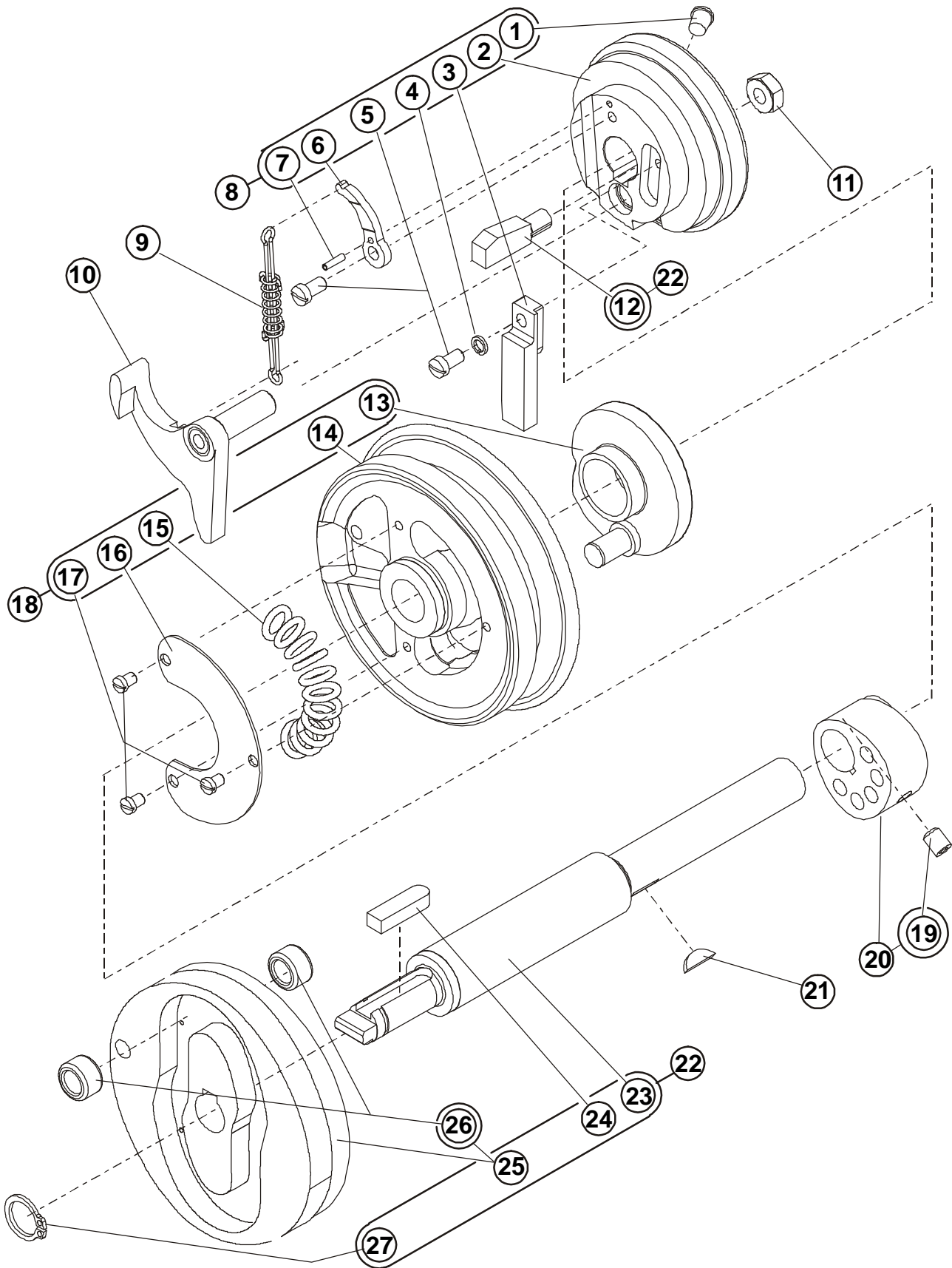

Released 09/2007

E-mail: service@amfreece.cz; parts@amfreece.cz; website: www.amfreece.com

Phones: +420 582 309 146 (Service), +420 582 309 286 (Spare Parts); Fax: +420 582 360 606

STOP WHEEL & STITCH DRIVE ASSEMBLY

DET	PART NUMBER	DESCRIPTION	QTY.
01	17.0004.7.253	Oil Cup	(1)
02	—	Hand Wheel	(1)
03	10.1155.2.000	Stop	(1)
04	08.6800.4.000	Washer	(1)
05	08.6010.4.012	Screw	(2)
06	10.1090.0.000	Arm	(1)
07	12.1014.0.004	Pin	(1)
08	10.1088.1.050	Stop Wheel Assembly	1
09	01.5450.0.000	Spring	1
10	14.1089.0.000	Clutch Dog	1
11	01.3007.0.000	Nut	1
12	10.1097.1.000	Key	1
13	10.1095.3.000	Drive Cam	(1)
14	10.1094.3.050	Stitch Pulley	(1)
15	01.5009.0.000	Spring	(1)
16	13.1096.0.000	Cover Plate	(1)
17	01.2019.0.000	Screw	(3)
18	10.1094.3.850	Line Stitch Pulley Assembly	(1)
19	01.1975.0.000	Screw	(1)
20	10.1093.2.000	Feed Cam	1
21	01.8002.0.000	Key	1
22	10.1091.0.000	Stitch Cam/Shaft Assembly	1
23	10.1091.1.801	Shaft	(1)
24	10.1091.1.803	Key	(1)
25	See Page 3-41	Stitch Cam	(—)
26	See Page 3-41	Roll	((—))
27	01.6384.0.000	Retaining Ring	(1)

Released 09/2007

E-mail: service@amfreece.cz; parts@amfreece.cz ; website: www.amfreece.com

Phones: +420 582 309 146 (Service), +420 582 309 286 (Spare Parts) ; Fax: +420 582 360 606

NEEDLE BAR DRIVE AND VIBRATOR

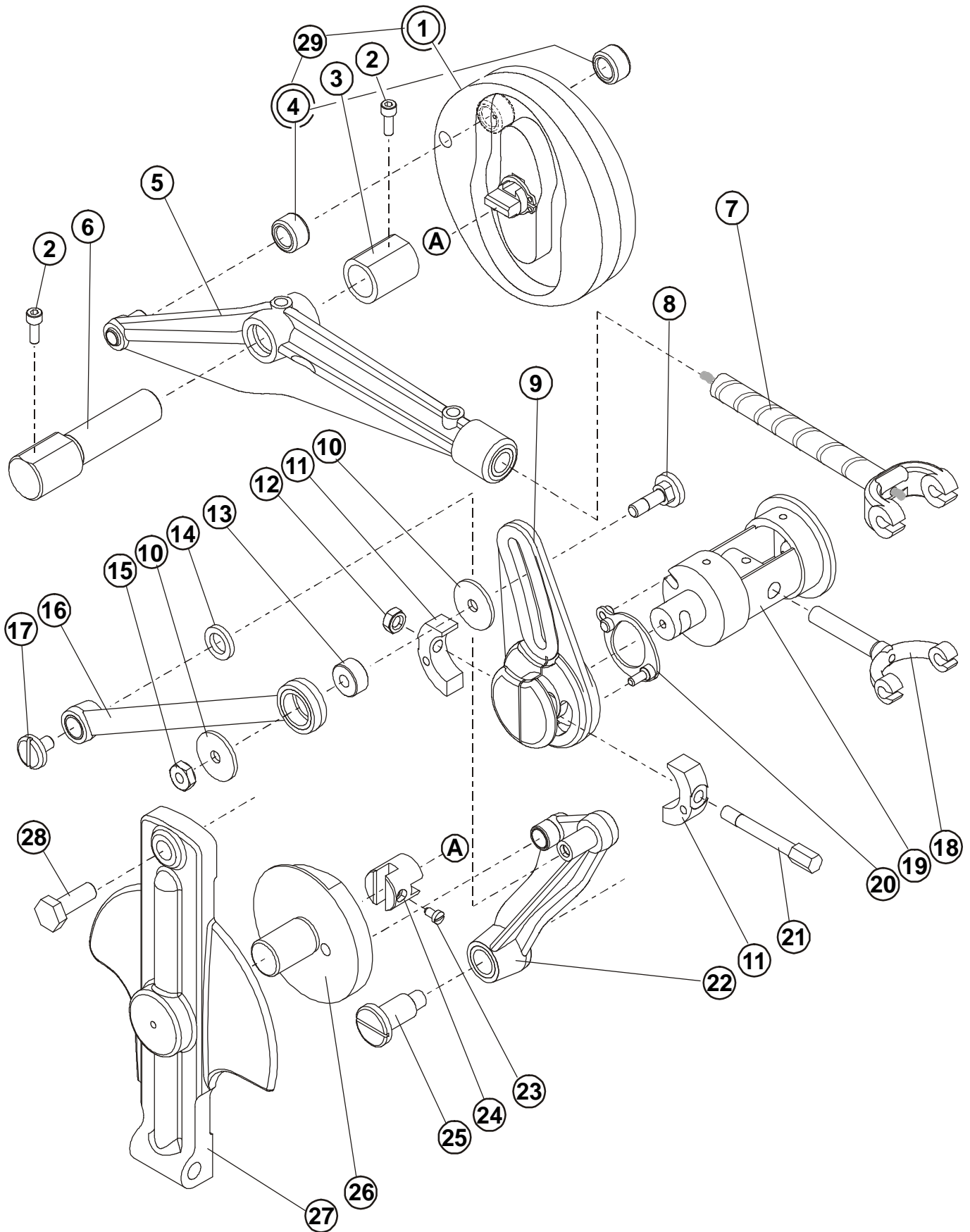

Released 09/2007

E-mail: service@amfreece.cz; parts@amfreece.cz ; website: www.amfreece.com
Phones: +420 582 309 146 (Service), +420 582 309 286 (Spare Parts) ; Fax: +420 582 360 606

NEEDLE BAR DRIVE AND VIBRATOR

DET	PART NUMBER	DESCRIPTION	QTY.
01	10.1091.0.802	Stitch Cam-101* Machin	(1)
02	01.2413.0.000	Screw	2
03	13.1049.0.000	Bushing	1
04	See Chart	Roll	((1))
05	14.1047.0.000	Stitch Drive Lever Assembly	1
06	13.1050.0.000	Pivot Stud	1
07	14.1046.0.050	Yoke Assembly	1
08	10.1037.0.000	Stud	1
09	10.1038.2.000	Vibrator Crank	1
10	10.1039.0.000	Washer	2
11	10.1147.0.000	Clamp Block	2
12	01.3005.0.000	Nut	1
13	10.1040.0.000	Bushing	1
14	10.1024.0.002	Washer (Std.) .0779"-.0782"	1
	10.1024.0.001	Washer (O/S.) .0782"-.0785"	
	10.1024.0.003	Washer (O/S.) .0776"-.0779"	
15	01.3020.0.001	Nut	1
16	14.1041.0.000	Vibrator Drag Link	1
17	01.2011.0.000	Screw	1
18	10.1034.0.000	Vibrator Yoke	1
19	14.1035.0.050	Vibrator Barrel Assembly	1
20	10.1153.0.000	Adjustment Plate	1
21	13.1036.0.000	Bolt	1
22	14.1043.0.000	Vibrator Cam Follower	1
23	10.1031.0.000	Screw	1
24	10.1076.0.000	Coupling Block	1
25	10.1044.0.000	Screw	1
26	05.0531.0.001	Vibrator Cam	1
27	10.1188.0.000	Support - Cam	1
28	01.2093.0.000	Screw	1
29	See Page 3-39	Stich Cam/Shaft Assembly	—

Roll Chart						
DET	04					
Dia.	Roll P/N	Size	Dia.	Roll P/N	Size	
.5000 +.0000 -.0003	10.1122.0.010	Std.	.5014 +.0000 -.0002	10.1122.0.012	#6 O.S.	
.5002 +.0000 -.0002	10.1122.0.999	#1 O.S.	.5018 +.0000 -.0002	10.1122.0.013	#7 O.S.	
.5004 +.0000 -.0002	10.1122.0.998	#2 O.S.	.5022 +.0000 -.0002	10.1122.0.014	#8 O.S.	
.5006 +.0000 -.0002	10.1122.0.980	#3 O.S.	.5026 +.0000 -.0002	10.1122.0.015	#9 O.S.	
.5010 +.0000 -.0002	10.1122.0.011	#5 O.S.	.5030 +.0000 -.0002	10.1122.0.016	#10 O.S.	

To be used on oversized cam slots

Released 09/2007

E-mail: service@amfreece.cz; parts@amfreece.cz; website: www.amfreece.com

Phones: +420 582 309 146 (Service), +420 582 309 286 (Spare Parts); Fax: +420 582 360 606

NEEDLE BAR AND GEAR

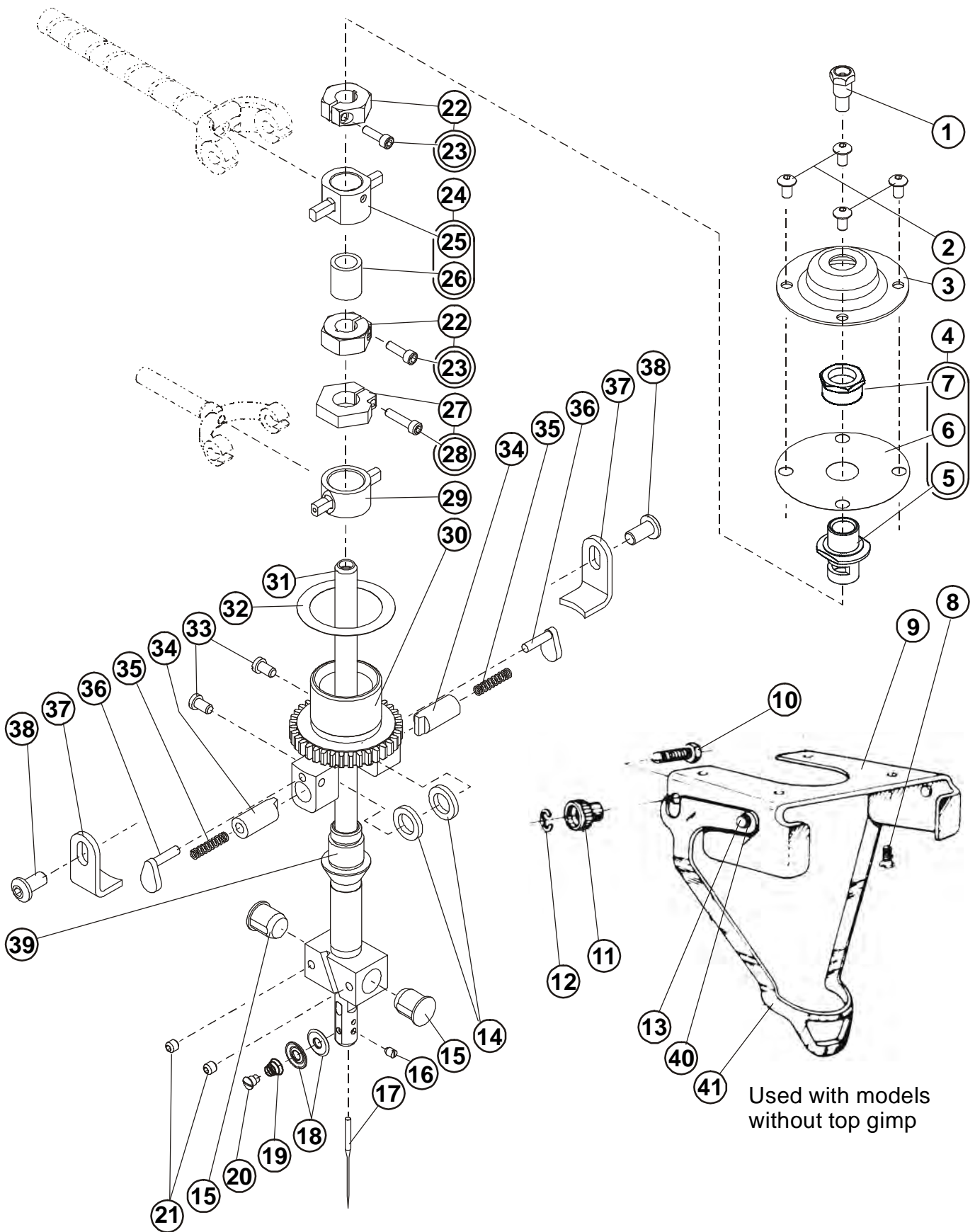

Used with models without top gimp

Released 09/2007

E-mail: service@amfreece.cz; parts@amfreece.cz; website: www.amfreece.com
 Phones: +420 582 309 146 (Service), +420 582 309 286 (Spare Parts); Fax: +420 582 360 606

NEEDLE BAR AND GEAR

DET	PART NUMBER	DESCRIPTION	QTY.
01	10.1032.0.000	Bushing	1
02	01.1661.0.001	Screw	4
03	10.1014.1.000	Cap	1
04	14.1016.1.050	Needle Bar Guide Assembly	1
05	14.1017.0.000	Guide (w/Nut)	(1)
06	14.1042.0.000	Diaphragm	(1)
07	10.1016.2.000	Nut	(1)
08	01.2075.0.000	Screw	4
09	10.1193.2.002	Bracket	1
10	01.2248.0.000	Screw	1
11	10.3512.0.000	Nut	1
12	01.6368.0.000	Screw	1
13	01.6834.0.000	Pin	2
14	10.1024.0.002	Washer (Std.) .0779"-.0782"	2
	10.1024.0.001	Washer (O/S.) .0782"-.0785"	
	10.1024.0.003	Washer (O/S.) .0776"-.0779"	
15	14.1025.1.000	Needle Bar Button	2
16	01.2193.0.000	Screw	1
17	02.0501.0.111	Needle	1
18	10.1029.1.000	Tension Disc	2
19	01.5167.0.000	Spring	1
20	10.1030.0.017	Screw	1
21	01.1889.0.001	Screw	2
22	10.1027.1.050	Clamp Nut Kit	2
23	01.2419.0.000	Screw	(2)
24	14.9005.0.050	Assembly	2
25	10.1045.2.000	Gimbal	(2)
26	01.7015.0.000	Bushing	(2)
27	14.4023.0.000	Adjustable Collar	1
28	01.2419.0.001	Screw	(1)
29	10.1033.1.000	Gimbal	1
30	10.1023.3.000	Needle Bar Gear	1
31	14.1028.0.000	Needle Bar	1
32	01.4081.0.005	Shim (.005")	1
	01.4081.0.006	Shim (.006")	
	01.4081.0.008	Shim (.008")	
	01.4081.0.009	Shim (.009")	
	01.4081.0.010	Shim (.010")	
	01.4081.0.011	Shim (.011")	
	01.4081.0.012	Shim (.012")	
33	01.2008.0.000	Screw	2
34	10.1022.0.000	Guide	2
35	01.5003.0.000	Spring	2
36	10.1021.2.000	Retainer Spring	2
37	14.1250.0.000	Needle Bar Gear Bracket	2
38	01.1983.0.000	Screw	2
39	14.1070.0.000	Block	1
40	01.6404.0.000	Retainer	2
41	10.1193.2.001	Guard	1

Released 09/2007

E-mail: service@amfreece.cz; parts@amfreece.cz ; website: www.amfreece.com

Phones: +420 582 309 146 (Service), +420 582 309 286 (Spare Parts) ; Fax: +420 582 360 606

THREAD HANDLING

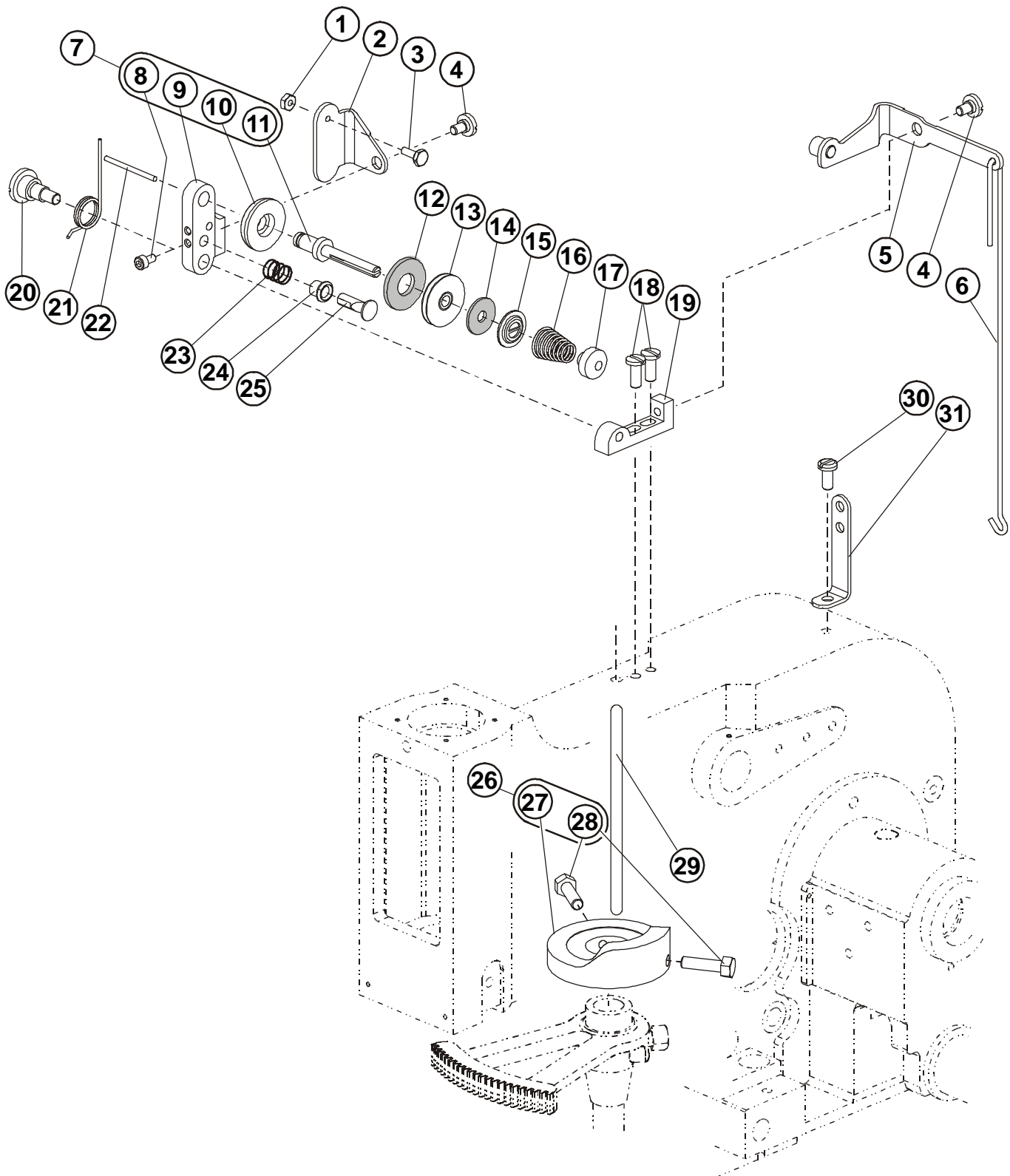

Released 09/2007

E-mail: service@amfreece.cz; parts@amfreece.cz ; website: www.amfreece.com
Phones: +420 582 309 146 (Service), +420 582 309 286 (Spare Parts) ; Fax: +420 582 360 606

THERAD HANDLING

DET	PART NUMBER	DESCRIPTION	QTY.
01	01.3025.0.000	Nut	1
02	10.1178.0.000	Release Lever	1
03	01.2509.0.000	Screw	1
04	01.1112.0.000	Screw	2
05	10.1177.0.000	Lever	1
06	10.1083.0.000	Link	1
07	10.1158.1.050	Kit - Arm* Tension	1
08	01.1393.0.001	Screw	(1)
09	10.1158.1.000	Tension Arm	(1)
10	01.4074.0.000	Spacer	(1)
11	01.1113.0.000	Stud	(1)
12	10.1077.0.000	Felt	1
13	10.1078.1.000	Tension Roller Assembly	1
14	10.1004.0.000	Felt Washer	1
15	10.1003.0.000	Washer	1
16	01.5603.0.000	Spring	1
17	10.4030.0.000	Nut	1
18	01.2039.0.000	Screw	2
19	10.1159.1.000	Tension Bracket	1
20	01.1114.0.000	Screw	1
21	01.5163.0.000	Spring	1
22	10.1010.0.000	Release Rod	1
23	01.5002.0.000	Spring	1
24	10.1009.0.000	Bushing	1
25	10.1008.0.000	Guide	1
26	10.1160.0.051	Line* Cam Assembly	1
27	10.1160.0.000	Cam	(1)
28	01.2362.0.000	Screw	(2)
29	01.6334.0.000	Rod	1
30	01.2247.0.000	Screw	1
31	05.0043.1.000	Thread Smoother	1

Revised 04/2009

E-mail: service@amfreece.cz; parts@amfreece.cz; website: www.amfreece.com

Phones: +420 582 309 146 (Service), +420 582 309 286 (Spare Parts); Fax: +420 582 360 606

CLAMP PLATE ASSEMBLY

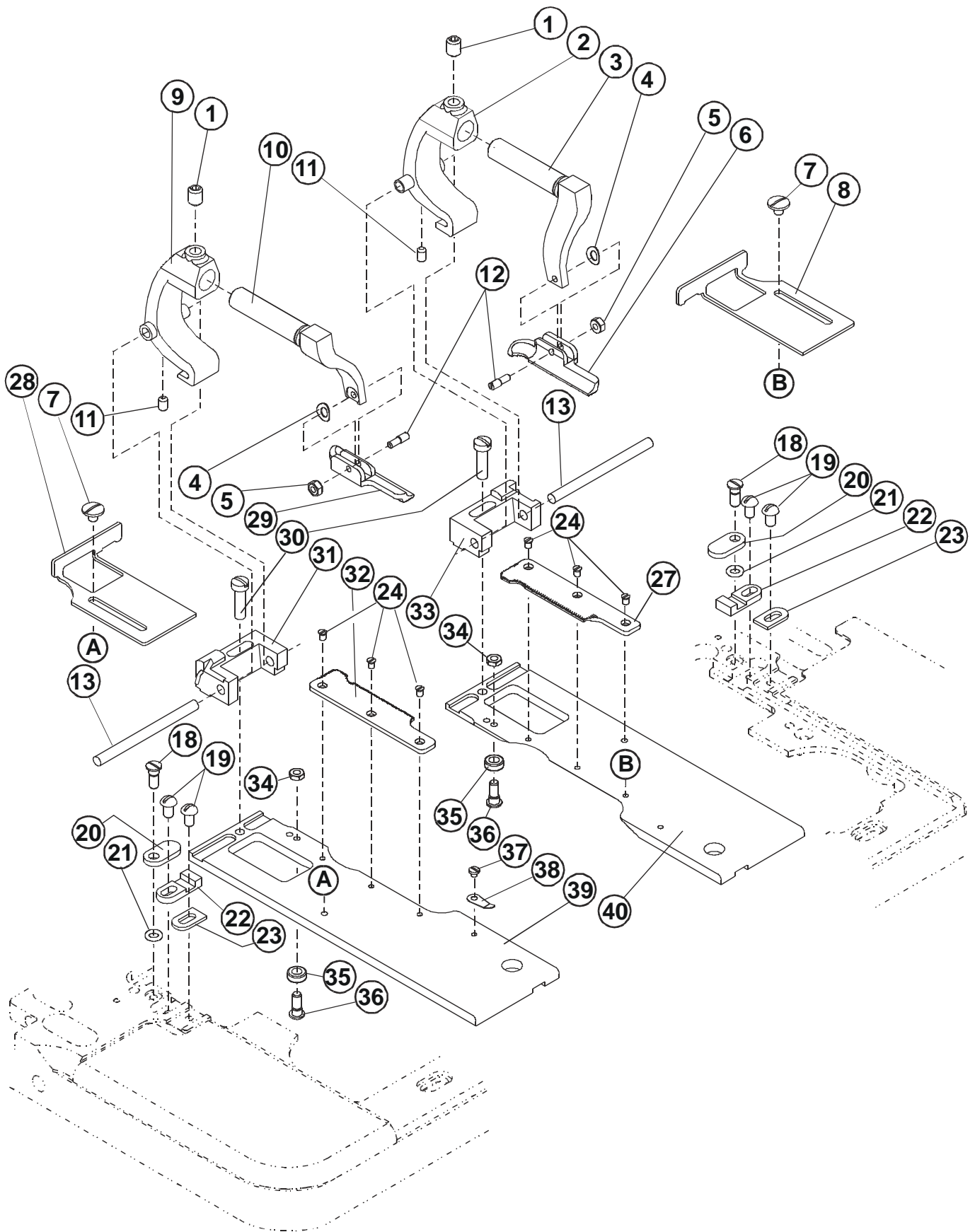

Revised 11/2008

E-mail: service@amfreece.cz; parts@amfreece.cz ; website: www.amfreece.com

Phones: +420 582 309 146 (Service), +420 582 309 286 (Spare Parts) ; Fax: +420 582 360 606

CLAMP PLATE ASSEMBLY

DET	PART NUMBER	DESCRIPTION	QTY.
01	01.1557.0.000	Set Screw #6-32 UNC-2B	2
02	14.2002.0.002	R. H. Clamp Arm Base	1
03	14.2003.0.000	Front R. H. Clamp Arm	1
04	01.4038.0.000	Spring Washer	2
05	01.3016.0.000	Nut	2
06	10.2046.1.751	R. H. Clamp Foot	1
07	01.2111.0.000	Screw	2
08	14.2059.0.000	R. H. Cloth Gauge	1
09	14.2002.0.001	L. H. Clamp Arm Base	1
10	14.2004.0.000	Front L.H. Clamp Arm	1
11	01.2557.0.001	Set Screw	2
12	01.1137.0.000	Set Screw	2
13	10.2571.0.000	Shaft	2
18	10.2051.2.000	Shoulder Screw	2
19	01.2312.0.000	Screw	4
20	10.2029.0.000	Latch	2
21	01.4426.0.000	O-Ring	2
22	10.2031.0.000	Slide	2
23	10.2032.0.000	Stop	2
24	01.2015.0.000	Screw	6
27	10.2044.0.002	R. H. Clamp Mat	1
28	14.2060.0.000	L.H. Cloth Gauge	1
29	10.2050.1.750	L. H. Clamp Foot	1
30	01.2051.0.000	Screw	2
31	14.2008.1.000	L.H. Block	1
32	10.2048.0.002	L. H. Clamp Mat	1
33	14.2007.1.000	R.H. Block	1
34	01.3001.0.000	Nut	2
35	10.2052.0.000	Roll	2
36	10.2051.2.000	Shoulder Screw	2
37	01.2053.0.000	Screw	1
38	10.2054.0.000	Clip	1
39	14.2047.0.019	L. H. Clamp Plate	1
40	14.2043.0.019	R.H. Clamp Plate	1

Revised 11/2008

E-mail: service@amfreece.cz; parts@amfreece.cz ; website: www.amfreece.com

Phones: +420 582 309 146 (Service), +420 582 309 286 (Spare Parts) ; Fax: +420 582 360 606

REGULAR TABLE

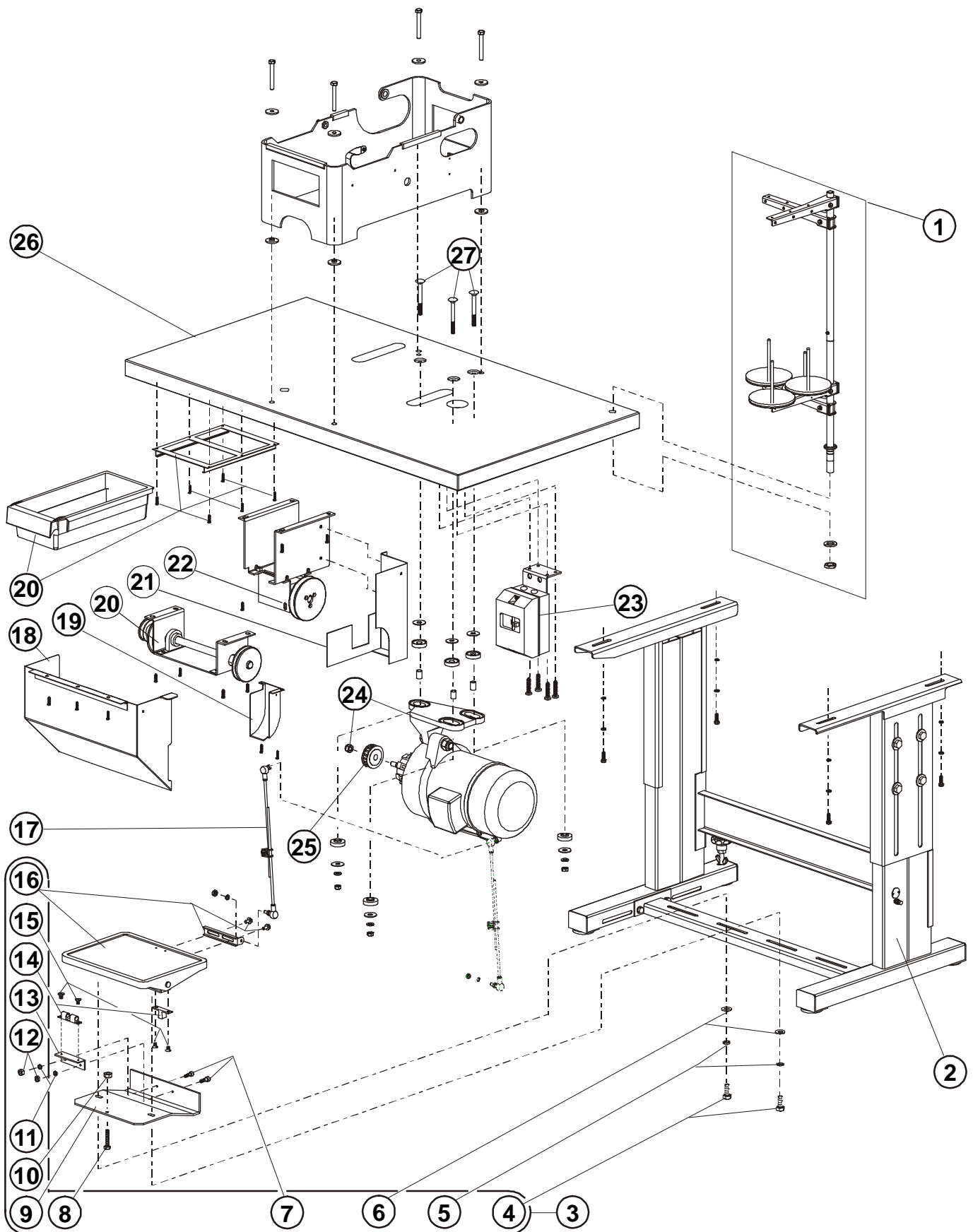

Released 09/2007

E-mail: service@amfreece.cz; parts@amfreece.cz ; website: www.amfreece.com
Phones: +420 582 309 146 (Service), +420 582 309 286 (Spare Parts) ; Fax: +420 582 360 606

REGULAR TABLE

DET	PART NUMBER	DESCRIPTION	QTY.
01	17.0003.6.156	Thread Stand	1
02	04.9000.0.123	Frame Kit Assembly	1
03	22.0218.0.000	Footswitch Assembly	1
04	08.6312.8.020	Screw M8x20	(2)
05	08.6802.8.000	Spring Washer	(2)
06	08.6852.8.000	Washer 8	(2)
07	08.6000.4.012	Screw M4x12	(2)
08	08.6312.8.040	Screw M8x12	(1)
09	22.0217.0.000	Foot Pedal Holder	(1)
10	08.6702.8.000	Nut M8	(1)
11	08.6800.4.000	Spring Washer 8	(2)
12	08.6700.4.000	Nut M4	(2)
13	22.0216.0.000	Latch Bracket	(1)
14	04.9000.0.802	Tension Latch	(1)
15	08.6100.4.006	Screw M4x6	(4)
16	04.9002.0.000	Footswitch Assembly	(1)
17	04.1956.1.000	Operating Rod-Ball Joint Assembly	(1)
18	04.9000.2.457	Cover 2 CE	1
19	17.0083.1.656	Cover 1 CE	1
20	17.0002.4.403	Jackshaft Assembly	1
21	04.9000.1.475	Cover 3 CE	1
22	17.0002.4.404	Auxialliary Pattern	3
23	06.1000.0.101	Motor Starter 1x110V/60Hz (12.0008.4.532)	—
	06.1000.0.001	Motor Starter 1x230V/60Hz (12.0008.4.533)	
	06.1000.0.201	Motor Starter 3x230V/60Hz (12.0008.4.534)	
	06.1000.0.301	Motor Starter 3x400V/50Hz (12.0008.4.535)	
24	17.0007.8.171	Motor FIR 110V / 60Hz 1Ph	—
	17.0007.8.172	Motor FIR 240V / 50Hz 1Ph	
	17.0007.8.173	Motor FIR 240—400V / 50—60 Hz 3Ph	
25	17.0055.4.414	Pulley	1
26	04.0026.2.000	Table	1
27	08.6532.8.070	Screw M8x70	3

Revised 10/2009

E-mail: service@amfreece.cz; parts@amfreece.cz ; website: www.amfreece.com

Phones: +420 582 309 146 (Service), +420 582 309 286 (Spare Parts) ; Fax: +420 582 360 606

STANDARD ACCESSORIES

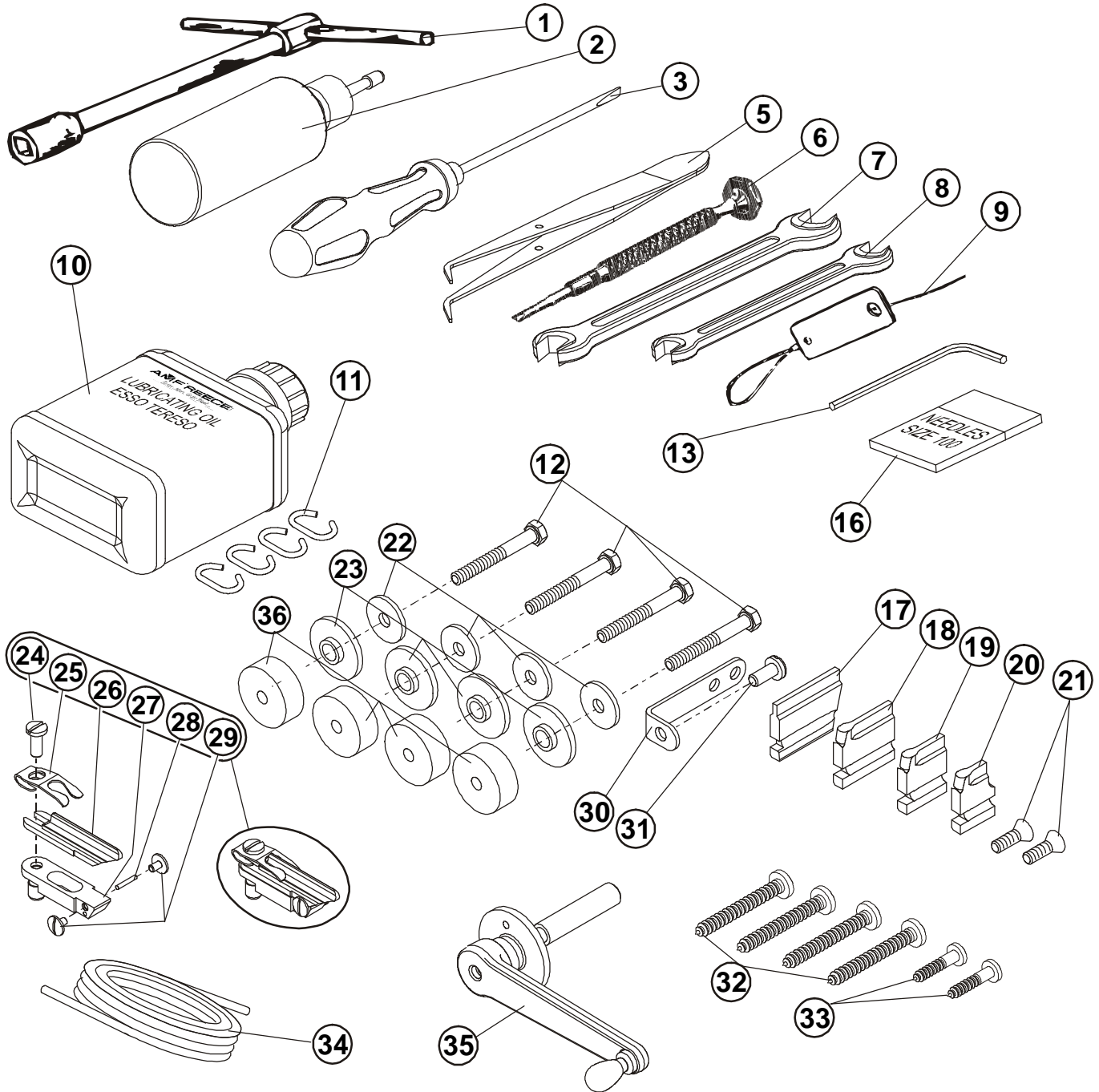

Released 09/2007

E-mail: service@amfreece.cz; parts@amfreece.cz ; website: www.amfreece.com
Phones: +420 582 309 146 (Service), +420 582 309 286 (Spare Parts) ; Fax: +420 582 360 606

STANDARD ACCESSORIES

DET	PART NUMBER	DESCRIPTION	QTY.
01	03.0048.2.000	Sq. Soket Wrench 7/16"	1
02	05.1322.0.000	Oil Can	1
03	03.0024.0.187	Screwdriver 3" Blade	1
04			
05	12.0008.6.215	Tweezers	1
06	03.0038.0.000	Screwdriver	1
07	03.0019.0.000	Wrench 1/4"	1
08	03.0018.0.000	Hex Wrench 5/16"	1
09	03.0020.0.000	Threading Wire	1
10	05.0090.1.000	Lubricating Oil 8 oz.68	1
11	05.0376.0.015	Hook - Belt	4
12	08.6300.8.060	Screw	4
13	03.0054.0.000	Hex Wrench 3/32"	1
14			
15			
16	02.0501.0.111	Needles	10
17	10.1069.0.016	Cutting Steel 1 1/4"	1
18	10.1069.0.005	Cutting Steel 1"	1
19	10.1069.0.003	Cutting Steel 3/4"	1
20	10.1069.0.001	Cutting Steel 1/2"	1
21	01.4406.0.000	Screw	1
22	17.0019.0.441	Washer	4
23	17.0095.1.272	Rubber Washer	4
24	01.2039.0.000	Screw	1
25	10.3074.0.011	Cloth Lifting Spring*CB	1
26	10.3072.0.023	Knife	1
27	10.3071.1.250	Knife Pad	1
28	01.6036.0.000	Pin	1
29	01.2102.0.000	Screw	2
30	05.0043.1.000	Thread Guide	1
31	01.2247.0.000	Screw	1
32	01.2616.0.000	Screw	4
33	01.2810.0.000	Screw	2
34	04.0561.0.312	Belt Ø 8 mm	6m
35	See Page 3-6	Crank Handle & Floating Shaft	—
36	19.0095.1.405	Rubber Washer	4

Released 09/2007

E-mail: service@amfreece.cz; parts@amfreece.cz ; website: www.amfreece.com

Phones: +420 582 309 146 (Service), +420 582 309 286 (Spare Parts) ; Fax: +420 582 360 606

OPTIONAL ACCESSORIES

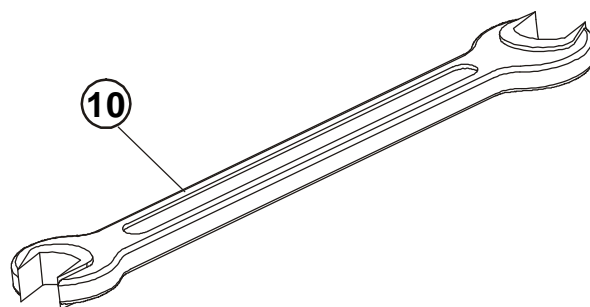
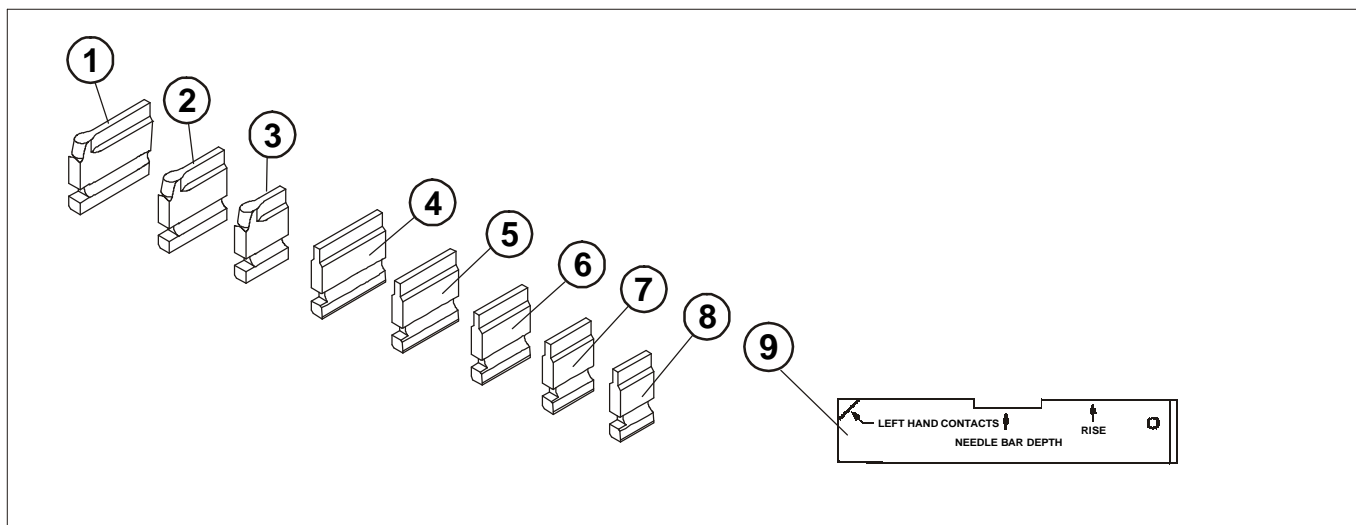

DET	PART NUMBER	DESCRIPTION	QTY.
1	10.1069.0.006	Cutting Steel 1 1/8"	—
2	10.1069.0.004	Cutting Steel 7/8"	—
3	10.1069.0.002	Cutting Steel 5/8"	—
4	10.1069.0.013	Cutting Steel 7/8"	—
5	10.1069.0.012	Cutting Steel 3/4"	—
6	10.1069.0.011	Cutting Steel 5/8"	—
7	10.1069.0.010	Cutting Steel 1/2"	—
8	10.1069.0.014	Cutting Steel 1"	—
9	03.0279.0.000	Gauge	—
10	12.0008.6.109	Fork Spanner 8-10	1

Released 09/2007

E-mail: service@amfreece.cz; parts@amfreece.cz ; website: www.amfreece.com

Phones: +420 582 309 146 (Service), +420 582 309 286 (Spare Parts) ; Fax: +420 582 360 606

INDEX

PART NUMBER	PAGE	DET	QTY	PART NUMBER	PAGE	DET	QTY	PART NUMBER	PAGE	DET	QTY
01.1006.0.000				01.2019.0.000	3-39	17	(3)	01.2102.0.000	3-51	29	2
01.1006.0.000	3-17	54	(2)	01.2020.0.000	3-37	28	(1)	01.2111.0.000	3-47	07	2
01.1020.1.000	3-25	19	2	01.2022.0.000	3-33	24	(2)	01.2128.0.000	3-7	37	2
01.1021.0.000	3-25	08	4	01.2024.0.000	3-17	50	(1)	01.2130.0.000	3-33	04	2
01.1028.0.000	3-33	16	1	01.2031.0.000	3-9	16	2	01.2131.0.000	3-23	09	4
01.1076.0.000	3-25	74	1	01.2032.1.000	3-11	15	1	01.2144.0.000	3-23	24	1
01.1095.0.000	3-35	24	1	01.2033.0.000	3-9	11	1	01.2146.0.000	3-33	13	1
01.1100.0.000	3-11	35	1	01.2035.0.000	3-7	19	(1)	01.2171.0.000	3-23	29	(1)
01.1112.0.000	3-45	04	2	01.2037.0.000	3-7	25	4	01.2175.0.000	3-23	08	2
01.1113.0.000	3-45	11	(1)	01.2038.0.000	3-29	28	1	01.2193.0.000	3-43	16	1
01.1114.0.000	3-45	20	1	01.2039.0.000	3-29	20	1	01.2241.0.002	3-25	65	2
01.1130.0.000	3-29	31	(1)	01.2039.0.000	3-29	29	2	01.2241.0.103	3-3	22	(4)+2
01.1132.0.000	3-33	21	1	01.2039.0.000	3-45	18	2	01.2241.0.103	3-3	27	(2)
01.1137.0.000	3-47	12	2	01.2039.0.000	3-51	24	1	01.2247.0.000	3-45	30	1
01.1147.0.002	3-11	33	1	01.2041.0.000	3-11	31	1	01.2247.0.000	3-51	31	1
01.1147.0.003	3-3	65	1	01.2041.0.000	3-21	44	1	01.2247.0.001	3-3	08	(3)
01.1151.0.000	3-21	04	1	01.2041.0.000	3-31	23	2	01.2247.0.001	3-3	57	(3)
01.1194.0.019	3-3	04	(1)	01.2041.0.000	3-33	14	1	01.2247.0.001	3-3	07	(3)+2
01.1238.0.000	3-25	28	(2)	01.2042.0.000	3-35	26	1	01.2247.0.003	3-3	56	(3)
01.1257.0.000	3-29	07	1	01.2043.0.000	3-15	27	2	01.2248.0.000	3-43	10	1
01.1393.0.001	3-45	08	(1)	01.2045.0.000	3-25	87	1				
01.1432.0.000	3-15	31	2	01.2046.0.000	3-25	51	1	01.2312.0.000			
01.1447.0.000	3-15	18	1	01.2046.0.000	3-25	52	1	01.2312.0.000	3-47	19	4
01.1457.0.000	3-25	59	1	01.2050.0.000	3-3	39	(1)	01.2318.0.000	3-17	16	(1)
01.1557.0.000	3-47	01	2	01.2051.0.000	3-47	30	2	01.2321.0.000	3-35	15	1
01.1594.0.000	3-15	43	1	01.2053.0.000	3-47	37	1	01.2324.0.000	3-13	26	1
01.1601.0.001	3-25	67	2	01.2056.0.000	3-17	65	1	01.2344.0.000	3-25	60	2
01.1601.0.007	3-25	69	2	01.2059.0.000	3-17	31	(1)	01.2344.0.000	3-33	01	1
01.1624.0.002	3-37	17	((1))	01.2063.0.000	3-21	09	1	01.2347.0.000	3-9	20	(2)
01.1649.0.004	3-25	79	1	01.2066.0.000	3-31	01	1	01.2361.0.000	3-17	13	(1)
01.1661.0.001	3-43	02	4	01.2067.0.000	3-9	13	2	01.2362.0.000	3-45	28	(2)
01.1686.0.401	3-25	22	((4))	01.2071.0.000	3-11	27	1	01.2386.0.000	3-9	01	2
01.1889.0.001	3-43	21	2	01.2073.0.000	3-17	10	(2)	01.2386.0.000	3-11	05	(1)
01.1975.0.000	3-39	19	(1)	01.2073.0.000	3-17	47	(3)	01.2388.0.000	3-9	24	2
01.1983.0.000	3-43	38	2	01.2075.0.000	3-7	26	4	01.2390.0.000	3-33	37	2
				01.2075.0.000	3-43	08	4				
01.2001.0.000				01.2075.0.001	3-31	24	2	01.2412.0.000			
01.2001.0.000	3-17	28	(4)	01.2077.0.000	3-23	32	1	01.2412.0.000	3-13	02	2
01.2002.0.000	3-7	20	2	01.2078.0.000	3-3	20	1	01.2412.0.000	3-25	40	((1))
01.2004.0.000	3-11	20	1	01.2079.0.000	3-15	46	2	01.2412.0.000	3-35	02	1
01.2006.0.000	3-15	12	1	01.2081.0.000	3-17	42	(1)	01.2413.0.000	3-41	02	2
01.2008.0.000	3-7	30	4	01.2081.0.000	3-17	59	1	01.2419.0.000	3-43	23	(2)
01.2008.0.000	3-43	33	2	01.2084.0.000	3-31	12	2	01.2419.0.001	3-21	35	((1))
01.2011.0.000	3-41	17	1	01.2085.0.000	3-13	18	2	01.2419.0.001	3-43	28	(1)
01.2013.0.000	3-29	12	(3)	01.2088.0.000	3-15	10	2	01.2482.0.000	3-25	44	(2)
01.2014.0.000	3-15	06	(2)	01.2093.0.000	3-41	28	1	01.2493.0.000	3-7	38	(1)
01.2015.0.000	3-47	24	6								
01.2016.0.000	3-13	13	1	01.2101.0.000				01.2509.0.000			
01.2016.0.000	3-15	40	(1)	01.2101.0.000	3-3	17	(1)	01.2509.0.000	3-45	03	1
01.2017.0.000	3-37	11	1	01.2102.0.000	3-29	26	2	01.2539.0.000	3-25	27	(1)

Revised 10/2009

e-mail: service@amfreece.cz; parts@amfreece.cz; website: www.amfreece.com

Phones: +420 582 309 146 (Service), +420 582 309 286 (Spare Parts); Fax: +420 582 360 606

INDEX

PART NUMBER	PAGE	DET	QTY	PART NUMBER	PAGE	DET	QTY	PART NUMBER	PAGE	DET	QTY
01.2539.0.001	3-25	24	(1)	01.3040.0.000	3-3	16	(1)	01.4081.0.006	3-43	32	1
01.2543.0.000	3-33	09	1	01.3040.0.000	3-3	43	(1)	01.4081.0.008	3-17	71	0
01.2547.1.441	3-3	62	4	01.3042.0.000	3-33	19	2	01.4081.0.008	3-43	32	1
01.2557.0.001	3-47	11	2	01.3059.0.000	3-9	06	1	01.4081.0.009	3-17	71	1
01.2616.0.000	3-51	32	4					01.4081.0.009	3-43	32	1
01.2667.0.000	3-17	17	(1)	01.3400.0.000				01.4081.0.010	3-17	71	0
01.2810.0.000	3-51	33	2	01.3400.0.000	3-21	12	1	01.4081.0.010	3-43	32	1
01.2888.0.402	3-3	35	(1)	01.3401.0.000	3-3	25	(2)	01.4081.0.011	3-17	71	0
01.2981.0.001	3-25	90	2	01.3402.0.000	3-3	11	(3)	01.4081.0.011	3-43	32	1
01.3001.0.000				01.3402.0.000	3-3	52	(6)	01.4081.0.012	3-17	71	0
01.3001.0.000	3-3	33	(2)	01.3404.0.000	3-25	30	(2)+(2)	01.4081.0.012	3-43	32	1
01.3001.0.000	3-17	55	1	01.3414.0.000	3-25	75	1				
01.3001.0.000	3-25	43	(2)	01.3415.0.000	3-25	80	1	01.4121.0.000			
01.3001.0.000	3-29	09	(2)	01.3436.0.000	3-37	22	(1)	01.4121.0.000	3-25	29	(4)
01.3001.0.000	3-47	34	2	01.4001.0.000				01.4154.0.000	3-15	44	1
01.3005.0.000	3-9	09	1	01.4001.0.000	3-29	08	(1)	01.4406.0.000	3-3	24	(4)+2
01.3005.0.000	3-17	45	(1)	01.4002.0.000	3-37	05	(1)	01.4406.0.000	3-51	21	1
01.3005.0.000	3-21	03	1	01.4003.0.000	3-29	32	(1)	01.4407.0.000	3-3	06	(4)+10
01.3005.0.000	3-23	33	1	01.4003.0.000	3-31	22	2	01.4407.0.000	3-35	03	1
01.3005.0.000	3-25	54	1	01.4004.0.000	3-37	18	((1))	01.4411.0.000	3-3	26	(2)
01.3005.0.000	3-31	17	1	01.4004.0.000	3-37	27	(1)	01.4412.0.000	3-7	35	2
01.3005.0.000	3-33	02	2	01.4005.0.000	3-13	22	1	01.4426.0.000	3-47	21	2
01.3005.0.000	3-35	10	1	01.4005.0.000	3-15	37	1	01.4445.0.000	3-25	82	2
01.3005.0.000	3-37	02	(1)	01.4005.0.000	3-25	46	(1)	01.4472.0.000	3-3	05	(3)+2
01.3005.0.000	3-41	12	1	01.4007.0.000	3-7	16	2	01.4472.0.000	3-3	55	(6)
01.3006.0.000	3-29	17	(2)	01.4009.0.000	3-7	14	1	01.4472.0.000	3-15	29	2
01.3007.0.000	3-9	05	6	01.4010.0.000	3-21	32	(1)	01.4503.0.000	3-33	18	2
01.3007.0.000	3-11	12	1	01.4011.0.000	3-35	11	1	01.4522.0.000	3-11	32	1
01.3007.0.000	3-25	42	(3)	01.4012.0.000	3-17	23	(1)	01.4522.0.000	3-13	14	1
01.3007.0.000	3-39	11	1	01.4013.0.000	3-17	51	(2)	01.4522.0.000	3-15	39	1
01.3010.0.000	3-21	28	1	01.4015.0.000	3-17	15	(1)	01.4559.0.000	3-25	34	(2)
01.3010.0.000	3-29	16	((1))	01.4018.0.000	3-9	02	4	01.4572.0.000	3-7	36	2
01.3011.0.000	3-31	02	1	01.4019.0.000	3-3	40	(1)	01.4672.0.002	3-3	19	1
01.3013.0.000	3-13	21	1	01.4019.0.000	3-33	25	(2)	01.4701.0.000	3-15	19	1
01.3013.0.000	3-15	38	(1)	01.4034.0.003	3-37	23	(1)	01.4751.0.000	3-21	19	(2)
01.3013.0.000	3-25	45	(1)	01.4038.0.000	3-47	04	2				
01.3014.0.000	3-3	37	(1)	01.4042.0.000	3-25	31	(2)+(2)	01.5002.0.000			
01.3015.0.000	3-9	14	2	01.4042.0.000	3-33	03	1	01.5002.0.000	3-45	23	1
01.3016.0.000	3-23	17	(1)	01.4046.0.000	3-15	11	2	01.5003.0.000	3-43	35	2
01.3016.0.000	3-25	86	1	01.4052.0.000	3-33	36	2	01.5005.0.001	3-21	13	1
01.3016.0.000	3-47	05	2	01.4061.0.000	3-9	21	(2)	01.5006.0.001	3-29	36	1
01.3018.0.000	3-17	72	1	01.4063.0.000	3-13	17	2	01.5007.0.000	3-37	03	(1)
01.3019.0.000	3-33	20	1	01.4063.0.000	3-25	68	1	01.5009.0.000	3-39	15	(1)
01.3020.0.000	3-21	39	(2)	01.4063.0.000	3-31	10	1	01.5010.0.000	3-37	21	(1)
01.3020.0.000	3-31	15	1	01.4067.0.000	3-25	02	2	01.5011.0.000	3-37	25	(1)
01.3020.0.001	3-41	15	1	01.4074.0.000	3-45	10	(1)	01.5013.0.000	3-25	64	1
01.3025.0.000	3-17	12	(1)	01.4081.0.005	3-17	71	0	01.5014.0.000	3-35	19	1
01.3025.0.000	3-21	26	(1)	01.4081.0.005	3-43	32	1	01.5015.0.000	3-25	73	1
01.3025.0.000	3-45	01	1	01.4081.0.006	3-17	71	0	01.5017.0.000	3-7	04	(1)
								01.5018.0.000	3-7	33	4

Revised 10/2009

e-mail: service@amfreece.cz; parts@amfreece.cz; website: www.amfreece.com

INDEX

PART NUMBER	PAGE	DET	QTY	PART NUMBER	PAGE	DET	QTY	PART NUMBER	PAGE	DET	QTY
01.5019.0.000	3-11	28	1	01.6074.0.000	3-25	10	(2)	03.0038.0.000	3-51	06	1
01.5020.0.000	3-11	18	1	01.6075.0.000	3-25	06	(2)	03.0048.2.000	3-51	01	1
01.5023.0.000	3-25	14	1	01.6135.0.000	3-11	06	(1)	03.0054.0.000	3-51	13	1
01.5026.0.000	3-17	43	((2))	01.6166.0.000	3-35	17	(1)	03.0279.0.000	3-52	09	—
01.5027.0.000	3-17	57	1	01.6280.0.000	3-23	04	(2)	03.6000.0.216	3-25	32	(2)
01.5028.0.000	3-17	63	1	01.6334.0.000	3-45	29	1				
01.5041.0.000	3-17	39	(1)	01.6345.0.000	3-9	08	1	04.0026.2.000			
01.5048.0.000	3-11	39	0	01.6350.1.000	3-37	20	((1))	04.0026.2.000	3-49	26	1
01.5054.0.000	3-15	03	2	01.6368.0.000	3-23	25	1	04.0561.0.312	3-51	34	6m
01.5055.0.000	3-11	22	1	01.6368.0.000	3-43	12	1	04.1956.1.000	3-49	17	(1)
01.5061.0.000	3-29	11	(1)	01.6384.0.000	3-39	27	(1)	04.9000.0.123	3-49	02	1
01.5062.0.000	3-3	12	1	01.6404.0.000	3-43	40	2	04.9000.0.802	3-49	14	(1)
01.5075.0.000	3-35	07	1	01.6422.0.005	3-7	02	(1)	04.9000.1.475	3-49	21	1
01.5088.0.000	3-31	04	1	01.6428.0.000	3-33	06	2	04.9000.2.457	3-49	18	1
				01.6528.0.000	3-23	27	1	04.9002.0.000	3-49	16	(1)
01.5123.0.000				01.6555.0.000	3-25	05	(2)				
01.5123.0.000	3-3	50	(1)	01.6612.0.000	3-23	07	(1)	05.0043.1.000			
01.5134.0.000	3-23	14	1	01.6638.0.000	3-37	08	((1))	05.0043.1.000	3-45	31	1
01.5163.0.000	3-45	21	1	01.6833.0.002	3-31	21	(1)	05.0043.1.000	3-51	30	1
01.5167.0.000	3-43	19	1	01.6834.0.000	3-43	13	2	05.0090.1.000	3-51	10	1
01.5172.0.000	3-13	04	1	01.6837.0.000	3-29	05	((1))	05.0144.0.000	3-25	77	1
01.5173.0.000	3-29	33	(1)	01.6839.0.001	3-15	02	2	05.0376.0.015	3-51	11	4
01.5433.0.000	3-23	28	1	01.6839.0.001	3-25	12	2	05.0531.0.001	3-41	26	1
01.5447.0.000	3-33	05	1	01.6982.0.002	3-11	37	0	05.1322.0.000	3-51	02	1
01.5448.0.000	3-33	10	1					05.1368.0.000	3-17	46	(1)
01.5450.0.000	3-39	09	1	01.7002.1.000				05.1385.0.000	3-3	31	(1)
01.5473.0.000	3-11	07	1	01.7002.1.000	3-37	19	((1))				
01.5475.0.000	3-25	58	1	01.7004.0.000	3-13	25	1	06.1000.0.001			
01.5603.0.000	3-45	16	1	01.7015.0.000	3-43	26	(2)	06.1000.0.001	3-49	23	—
01.5619.0.000	3-17	38	(1)	01.7022.0.000	3-17	53	(2)	06.1000.0.101	3-49	23	—
01.5620.0.000	3-17	09	(1)	01.7023.0.000	3-13	11	1	06.1000.0.201	3-49	23	—
01.5683.0.000	3-7	17	3	01.7038.1.000	3-33	33	(1)	06.1000.0.301	3-49	23	—
				01.7043.0.000	3-13	10	1				
01.6004.0.000				01.7309.0.901	3-21	41	(2)	07.0400.0.000			
01.6004.0.000	3-17	68	(1)	01.7329.0.000	3-3	32	(2)	07.0400.0.000	3-33	30	(1)
01.6005.0.000	3-35	18	(1)	01.7435.1.000	3-23	11	1	07.0401.0.000	3-17	73	1
01.6006.0.000	3-25	41	((1))	01.7464.0.000	3-7	03	(1)	07.0401.0.009	3-17	33	((1))
01.6006.0.000	3-29	04	((1))	01.7630.0.001	3-21	20	(1)	08.6000.4.012	3-49	07	(2)
01.6010.0.000	3-23	20	(1)	01.8002.0.000	3-39	21	1				
01.6013.0.000	3-17	36	((1))	01.8404.0.001	3-25	38	(1)	08.6000.4.040	0	00	0
01.6014.0.000	3-25	72	1+(1)					08.6000.4.040	3-35	01	1
01.6014.0.000	3-37	16	((1))	02.0501.0.111				08.6010.4.012	3-39	05	(2)
01.6018.0.000	3-17	37	((2))	02.0501.0.111	3-43	17	1	08.6100.4.006	3-49	15	(4)
01.6020.0.000	3-31	20	(1)	02.0501.0.111	3-51	16	10	08.6300.8.060	3-51	12	4
01.6023.0.000	3-7	22	(1)					08.6312.8.020	3-49	04	(2)
01.6026.0.000	3-29	15	((1))	03.0018.0.000				08.6312.8.040	3-49	08	(1)
01.6030.0.000	3-35	22	(1)	03.0018.0.000	3-51	08	1	08.6400.5.305	3-33	32	(2)
01.6031.0.000	3-15	14	1	03.0019.0.000	3-51	07	1	08.6532.8.070	3-49	27	3
01.6036.0.000	3-29	25	1	03.0020.0.000	3-51	09	1	08.6700.4.000	3-35	05	2
01.6036.0.000	3-51	28	1	03.0024.0.187	3-51	03	1	08.6700.4.000	3-49	12	(2)

Revised 10/2009

e-mail: service@amfreece.cz; parts@amfreece.cz; website: www.amfreece.com

Phones: +420 582 309 146 (Service), +420 582 309 286 (Spare Parts); Fax: +420 582 360 606

INDEX

PART NUMBER	PAGE	DET	QTY	PART NUMBER	PAGE	DET	QTY	PART NUMBER	PAGE	DET	QTY
08.6702.8.000	3-49	10	(1)	10.1061.1.000	3-21	27	(1)	10.1098.2.050	3-37	13	(1)
08.6707.1.000	3-15	41	4	10.1062.0.000	3-21	10	1	10.1099.0.000	3-37	29	(1)
08.6800.4.000	3-39	04	(1)	10.1066.2.000	3-21	05	1				
08.6800.4.000	3-49	11	(2)	10.1068.0.901	3-29	03	(1)	10.1100.0.000			
08.6802.8.000	3-49	05	(2)	10.1068.1.050	3-29	02	((1))	10.1100.0.000	3-37	24	(1)
08.6850.4.000	3-11	21	1	10.1069.0.001	3-29	19	1	10.1101.0.000	3-37	26	(1)
08.6850.7.001	3-25	66	2	10.1069.0.001	3-51	20	1	10.1107.0.801	3-33	27	(1)
08.6850.7.001	3-29	34	(1)	10.1069.0.002	3-52	03	—	10.1109.3.000	3-33	22	1
08.6852.6.000	3-31	16	1	10.1069.0.003	3-51	19	1	10.1113.0.000	3-35	12	1
08.6852.8.000	3-49	06	(2)	10.1069.0.004	3-52	02	—	10.1114.1.000	3-35	08	(1)
				10.1069.0.005	3-51	18	1	10.1115.0.000	3-35	28	1
10.0625.0.000				10.1069.0.006	3-52	01	—	10.1117.0.000	3-35	13	1
10.0625.0.000	3-3	38	1	10.1069.0.010	3-52	07	—	10.1118.0.000	3-35	16	1
10.1001.7.050	3-3	64	1	10.1069.0.011	3-52	06	—	10.1119.0.000	3-35	20	1
10.1003.0.000	3-45	15	1	10.1069.0.012	3-52	05	—	10.1120.0.000	3-35	21	1
10.1004.0.000	3-45	14	1	10.1069.0.013	3-52	04	—	10.1121.0.017	3-35	25	1
10.1008.0.000	3-45	25	1	10.1069.0.014	3-52	08	—				
10.1009.0.000	3-45	24	1	10.1069.0.016	3-51	17	1	10.1122.0.010			
10.1010.0.000	3-45	22	1					10.1122.0.010	3-41	04	0
10.1014.1.000	3-43	03	1	10.1071.1.023				10.1122.0.011	3-41	04	0
10.1016.2.000	3-43	07	(1)	10.1071.1.023	3-29	14	(1)	10.1122.0.012	3-41	04	0
10.1021.2.000	3-43	36	2	10.1072.0.000	3-29	10	(1)	10.1122.0.013	3-41	04	0
10.1022.0.000	3-43	34	2	10.1073.1.000	3-29	13	(1)	10.1122.0.014	3-41	04	0
10.1023.3.000	3-43	30	1	10.1074.0.000	3-29	18	(1)	10.1122.0.015	3-41	04	0
10.1024.0.001	3-41	14	1	10.1074.0.250	3-29	37	1	10.1122.0.016	3-41	04	0
10.1024.0.001	3-43	14	2	10.1075.1.000	3-15	05	(1)	10.1122.0.017	3-35	23	1
10.1024.0.002	3-41	14	1	10.1075.1.051	3-15	04	1	10.1122.0.980	3-41	04	0
10.1024.0.002	3-43	14	2	10.1076.0.000	3-41	24	1	10.1122.0.997	3-21	07	—
10.1024.0.003	3-41	14	1	10.1077.0.000	3-45	12	1	10.1122.0.998	3-21	07	1
10.1024.0.003	3-43	14	2	10.1078.1.000	3-45	13	1	10.1122.0.998	3-41	04	0
10.1027.1.050	3-43	22	2	10.1080.0.000	3-3	61	1	10.1122.0.999	3-21	07	1
10.1029.1.000	3-43	18	2	10.1081.0.000	3-3	60	1	10.1122.0.999	3-41	04	0
				10.1082.0.001	3-3	15	(1)				
10.1030.0.017				10.1082.0.051	3-3	14	1	10.1124.0.000			
10.1030.0.017	3-43	20	1	10.1083.0.000	3-35	14	1	10.1124.0.000	3-31	18	1
10.1031.0.000	3-41	23	1	10.1083.0.000	3-45	06	1	10.1125.2.000	3-31	03	1
10.1032.0.000	3-43	01	1	10.1086.0.000	3-37	04	(1)	10.1126.0.000	3-31	14	1
10.1033.1.000	3-43	29	1	10.1087.0.000	3-37	06	(1)	10.1127.3.000	3-31	19	1
10.1034.0.000	3-41	18	1	10.1088.1.050	3-39	08	1	10.1145.2.000	3-3	18	1
10.1037.0.000	3-41	08	1	10.1090.0.000	3-39	06	(1)	10.1147.0.000	3-41	11	2
10.1038.2.000	3-41	09	1	10.1091.0.000	3-39	22	1	10.1149.0.000	3-37	30	1
10.1039.0.000	3-41	10	2	10.1091.0.802	3-41	01	(1)	10.1151.0.000	3-3	13	1
10.1040.0.000	3-41	13	1	10.1091.1.801	3-39	23	(1)	10.1153.0.000	3-41	20	1
10.1044.0.000	3-41	25	1	10.1091.1.803	3-39	24	(1)	10.1155.2.000	3-39	03	(1)
10.1045.2.000	3-43	25	(2)	10.1093.2.000	3-39	20	1	10.1158.1.000	3-45	09	(1)
10.1053.0.000	3-21	16	(2)	10.1094.3.050	3-39	14	(1)	10.1158.1.050	3-45	07	1
10.1053.0.000	3-31	05	1	10.1094.3.850	3-39	18	(1)	10.1159.1.000	3-45	19	1
10.1054.0.000	3-21	21	1	10.1095.3.000	3-39	13	(1)	10.1160.0.000	3-45	27	(1)
10.1055.0.000	3-21	22	1	10.1097.1.000	3-39	12	1	10.1160.0.051	3-45	26	1
10.1060.2.000	3-21	23	1	10.1098.0.850	3-37	12	1	10.1163.0.000	3-29	06	((1))

Revised 10/2009

e-mail: service@amfreece.cz; parts@amfreece.cz; website: www.amfreece.com

INDEX

PART NUMBER	PAGE	DET	QTY	PART NUMBER	PAGE	DET	QTY	PART NUMBER	PAGE	DET	QTY
10.1167.1.000	3-33	07	1	10.2024.0.000	3-25	47	(1)	10.2262.0.000	3-31	26	1
10.1168.0.000	3-33	12	1	10.2025.0.000	3-25	53	1	10.2263.0.000	3-23	02	1
10.1169.0.000	3-33	08	1	10.2025.0.017	3-25	50	1	10.2264.0.000	3-23	01	2
10.1170.0.000	3-33	35	1	10.2027.1.000	3-25	25	(1)	10.2571.0.000	3-47	13	2
10.1177.0.000	3-45	05	1	10.2028.0.000	3-15	07	(2)				
10.1178.0.000	3-45	02	1	10.2028.1.000	3-25	26	(1)	10.3001.3.000			
10.1180.0.000	3-11	34	1	10.2029.0.000	3-47	20	2	10.3001.3.000	3-9	25	1
10.1181.0.000	3-11	36	1	10.2031.0.000	3-47	22	2	10.3002.0.000	3-21	43	1
10.1188.0.000	3-41	27	1	10.2032.0.000	3-47	23	2	10.3006.0.090	3-21	40	(1)
10.1193.2.001	3-43	41	1	10.2033.0.000	3-25	16	1	10.3007.0.000	3-21	38	(2)
10.1193.2.002	3-43	09	1	10.2033.0.801	3-25	11	(1)	10.3008.0.000	3-21	29	1
10.1194.0.004				10.2034.0.000	3-25	13	1	10.3009.0.000	3-15	47	1
10.1194.0.004	3-3	10	(1)	10.2034.0.801	3-25	15	(1)	10.3010.0.000	3-15	08	(1)
10.1194.0.007	3-7	09	1	10.2036.0.000	3-25	09	2	10.3010.0.051	3-15	09	1
10.1194.0.008	3-3	03	(1)	10.2039.0.000	3-25	03	1	10.3011.0.000	3-15	36	(1)
10.1194.0.009	3-3	23	(1)	10.2041.0.000	3-25	07	2	10.3011.0.051	3-15	34	1
10.1194.0.010	3-3	53	(1)	10.2042.0.000	3-25	01	2	10.3012.0.000	3-15	24	1
10.1194.0.013	3-7	08	1	10.2044.0.002	3-47	27	1	10.3013.0.000	3-15	35	(1)
10.1194.0.014	3-7	11	1	10.2046.1.751	3-47	06	1	10.3016.0.000	3-15	42	4
10.1194.0.016	3-7	10	1	10.2048.0.002	3-47	32	1	10.3018.0.000	3-15	20	1
10.1194.0.020	3-3	02	(1)	10.2050.1.750	3-47	29	1	10.3019.1.006	3-13	15	1
10.1194.0.023	3-3	01	1	10.2051.2.000	3-47	18	2	10.3020.0.006	3-13	24	1
10.1194.0.024	3-3	21	1	10.2051.2.000	3-47	36	2	10.3026.0.000	3-15	22	1
10.1194.0.025	3-3	49	1	10.2052.0.000	3-47	35	2	10.3026.0.000	3-25	81	1
10.1194.0.028	3-3	59	(1)	10.2054.0.000	3-47	38	1	10.3027.0.000	3-9	15	1
10.1194.1.005	3-3	58	(1)	10.2061.0.000	3-33	15	1	10.3028.0.000	3-9	12	2
10.1194.1.012	3-3	28	(1)	10.2070.1.000	3-11	10	1	10.3029.1.000	3-11	26	1
10.1194.2.006	3-3	54	(1)	10.2071.0.000	3-11	11	1				
10.1198.1.000	3-17	41	(1)	10.2072.0.000	3-11	08	1	10.3031.0.000			
10.2001.4.250				10.2073.0.000	3-11	04	1	10.3031.0.000	3-11	14	1
10.2001.4.250	3-13	27	1	10.2074.0.000	3-25	56	1	10.3032.1.000	3-11	25	1
10.2003.0.000	3-3	36	1+(1)	10.2075.0.000	3-25	57	1	10.3033.0.020	3-13	01	1
10.2004.1.000	3-3	44	1	10.2250.1.000				10.3034.0.258	3-13	12	1
10.2005.0.000	3-3	45	1	10.2250.1.000	3-31	11	1	10.3035.1.000	3-9	07	2
10.2006.2.000	3-13	08	1	10.2251.0.001	3-31	06	1	10.3036.0.000	3-9	10	1
10.2007.0.000	3-13	09	1	10.2252.0.000	3-31	08	1	10.3039.0.000	3-7	07	(1)
10.2007.0.350	3-33	11	1	10.2253.0.000	3-31	09	1	10.3039.1.050	3-7	01	1
10.2008.0.000	3-11	01	1	10.2255.2.150	3-15	01	1	10.3040.1.000	3-7	06	(1)
10.2011.0.000	3-11	29	1	10.2255.3.200	3-15	01	1	10.3042.0.000	3-7	05	(1)
10.2012.0.000	3-11	09	1	10.2256.0.000	3-15	26	1	10.3045.0.000	3-7	18	1
10.2014.0.000	3-11	16	1	10.2257.0.000	3-13	06	1	10.3046.0.000	3-7	39	1
10.2015.0.000	3-11	17	1	10.2258.0.000	3-13	03	1	10.3047.1.050	3-7	23	1
10.2016.0.000	3-35	27	1	10.2259.0.000	3-13	05	1	10.3048.0.000	3-7	21	1
10.2017.0.000	3-3	63	1	10.2260.0.001	3-13	07	1	10.3049.0.000	3-7	15	1
10.2018.1.250	3-31	13	1	10.2260.0.167	3-13	07	1	10.3050.0.000	3-7	13	1
10.2019.0.000	3-25	88	1	10.2260.0.200	3-13	07	1	10.3051.0.000	3-7	12	1
10.2020.0.000	3-25	89	1	10.2260.0.217	3-13	07	1	10.3052.0.000	3-7	32	4
10.2022.0.000	3-25	84	1	10.2260.0.200	3-13	07	1	10.3053.1.000	3-7	31	1
				10.2261.0.030	3-31	25	1	10.3054.2.000	3-7	24	1
				10.2261.0.040	3-31	25	1	10.3061.0.300	3-9	23	(2)

Revised 10/2009

e-mail: service@amfreece.cz; parts@amfreece.cz; website: www.amfreece.com

Phones: +420 582 309 146 (Service), +420 582 309 286 (Spare Parts); Fax: +420 582 360 606

INDEX

PART NUMBER	PAGE	DET	QTY	PART NUMBER	PAGE	DET	QTY	PART NUMBER	PAGE	DET	QTY
10.3062.1.000	3-9	19	(1)	10.4024.0.000	3-21	33	(1)	13.3023.0.000	3-25	71	1
10.3064.0.830	3-9	17	1	10.4026.0.000	3-17	48	(1)	13.3079.0.000	3-7	28	1
10.3066.0.008	3-9	03	1	10.4029.0.000	3-17	60	1	13.3083.0.000	3-7	34	1
10.3066.0.011	3-9	04	3	10.4030.0.000	3-17	64	1	13.3094.2.000	3-25	83	1
10.3067.4.254	3-29	27	1	10.4030.0.000	3-45	17	1	13.3131.0.000	3-25	78	1
10.3070.0.250	3-29	35	(1)	10.4031.0.000	3-17	62	1				
10.3070.0.251	3-29	30	1	10.4032.0.000	3-17	61	1	14.1016.1.050			
10.3071.1.520				10.4035.0.000	3-17	44	(1)	14.1016.1.050	3-43	04	1
10.3071.1.250	3-29	24	1	10.4036.0.000	3-17	58	1	14.1017.0.000	3-43	05	(1)
10.3071.1.250	3-51	27	1	10.4037.0.000	3-17	56	1	14.1025.1.000	3-43	15	2
10.3072.0.023	3-51	26	1	10.4039.0.000	3-17	27	(2)	14.1026.0.000	3-21	11	1
10.3072.0.024	3-29	22	1	10.4202.0.000	3-17	40	(1)	14.1028.0.000	3-43	31	1
10.3074.0.011	3-29	21	1	10.4203.0.000	3-17	14	(1)	14.1029.0.000	3-33	29	(1)
10.3074.0.011	3-51	25	1	10.5001.2.000				14.1035.0.050	3-41	19	1
10.3080.0.000	3-7	27	2	10.5001.2.000	3-3	30	(1)	14.1041.0.000	3-41	16	1
10.3081.0.000	3-33	17	1	10.5001.2.051	3-3	29	1	14.1042.0.000	3-43	06	(1)
10.3082.0.000	3-7	29	2	10.5002.0.000	3-3	34	(1)	14.1043.0.000	3-41	22	1
10.3086.0.000	3-23	15	1	10.5005.1.900	3-3	42	(1)	14.1046.0.050	3-41	07	1
10.3089.2.000	3-23	26	1	10.5006.1.000	3-3	41	(1)	14.1047.0.000	3-41	05	1
10.3203.0.000	3-23	22	(2)	10.5021.0.000	3-3	48	1	14.1058.0.000	3-21	02	1
10.3205.0.000	3-23	19	(1)	10.9008.0.050	3-17	19	(1)	14.1059.0.000	3-21	01	1
10.3206.0.000	3-23	16	(1)	11.3259.0.001				14.1064.2.000	3-21	08	1
10.3250.1.000	3-15	16	2	11.3259.0.001	3-15	30	1	14.1067.0.000	3-21	06	1
10.3252.1.000	3-15	17	2	11.3259.0.002	3-15	32	1	14.1070.0.000	3-43	39	1
10.3253.0.000	3-15	28	1					14.1084.0.000	3-37	09	((1))
10.3254.0.000	3-15	25	1	12.0008.6.109				14.1085.0.000	3-37	07	(1)
10.3258.0.000	3-15	45	1	12.0008.6.109	3-52	10	1	14.1085.0.850	3-37	01	1
10.3262.0.250	3-15	13	1	12.0008.6.215	3-51	05	1	14.1085.0.901	3-37	10	((1))
10.3300.0.006	3-13	16	1	12.1010.0.012	3-17	34	(1+(1))	14.1089.0.000	3-39	10	1
10.3301.1.006	3-13	20	2	12.1010.0.220	3-25	63	1	14.1099.0.000	3-35	04	1
10.3302.0.000	3-13	19	1	12.1014.0.004	3-39	07	(1)	14.1102.0.000	3-37	14	((1))
10.3303.0.000	3-13	23	1	12.1015.0.001	3-11	38	0	14.1108.0.050	3-33	23	1
10.3512.0.000	3-43	11	1	12.1015.0.001	3-35	09	(1)	14.1108.0.901	3-33	26	((1))
10.4001.0.150				12.2010.0.000	3-11	30	1	14.1197.1.000	3-17	18	(1)
10.4001.0.150	3-17	01	1	12.4021.0.312	3-33	28	(1)	14.1236.0.000	3-21	15	1
10.4002.1.000	3-17	20	((1))	12.8000.1.001	3-3	09	(1)	14.1250.0.000	3-43	37	2
10.4003.0.000	3-17	21	((1))	13.1036.0.000				14.2002.0.001			
10.4004.0.000	3-17	04	(1)	13.1036.0.000	3-41	21	1	14.2002.0.001	3-47	09	1
10.4006.0.000	3-17	02	(1)	13.1049.0.000	3-41	03	1	14.2002.0.002	3-47	02	1
10.4007.0.000	3-17	06	(1)	13.1050.0.000	3-41	06	1	14.2003.0.000	3-47	03	1
10.4010.2.000	3-17	08	(1)	13.1052.0.001	3-21	17	(1)	14.2004.0.000	3-47	10	1
10.4012.0.004	3-17	66	1	13.1096.0.000	3-39	16	(1)	14.2007.1.000	3-47	33	1
10.4016.0.000	3-17	25	(1)	13.2021.0.023	3-25	85	1	14.2008.1.000	3-47	31	1
10.4017.0.000	3-17	26	(1)	13.2086.0.000	3-25	49	(1)	14.2009.0.000	3-25	91	2
10.4018.0.000	3-17	29	(1)	13.2087.1.000	3-25	61	1	14.2013.0.000	3-11	19	1
10.4019.0.000	3-17	30	(2)	13.2088.0.000	3-25	62	1	14.2023.1.000	3-25	39	(1)
10.4020.0.000	3-21	36	1	13.3022.1.023	3-25	70	1	14.2024.0.000	3-25	37	(1)
10.4021.0.000	3-17	49	(1)					14.2026.0.002	3-25	21	(1)
								14.2026.0.003	3-25	48	(1)

Revised 10/2009

e-mail: service@amfreece.cz; parts@amfreece.cz; website: www.amfreece.com

INDEX

PART NUMBER	PAGE	DET	QTY	PART NUMBER	PAGE	DET	QTY	PART NUMBER	PAGE	DET	QTY
14.2026.0.005	3-25	35	(1)	17.0002.4.403							
14.2026.0.006	3-25	36	(1)	17.0002.4.403	3-49	20	1				
14.2026.0.050	3-25	20	1	17.0002.4.404	3-49	22	3				
14.2039.0.801	3-25	04	(1)	17.0003.6.156	3-49	01	1				
14.2040.0.000	3-25	18	1	17.0004.7.253	3-39	01	(1)				
14.2040.0.901	3-25	17	(1)	17.0007.8.171	3-49	24	—				
14.2043.0.019	3-47	40	1	17.0007.8.172	3-49	24	—				
14.2047.0.019	3-47	39	1	17.0007.8.173	3-49	24	—				
14.2059.0.000	3-47	08	1	17.0019.0.441	3-51	22	4				
14.2060.0.000	3-47	28	1	17.0031.1.401	3-11	23	1				
14.2069.0.000	3-23	05	(1)	17.0031.1.401	3-21	14	1				
14.2069.0.050	3-23	03	1	17.0055.4.414	3-49	25	1				
14.2069.0.802	3-23	06	(1)	17.0083.1.656	3-49	19	1				
14.2254.1.901	3-31	07	1	17.0094.5.309	3-11	24	1				
14.2261.0.000	3-31	25	1	17.0095.1.272	3-51	23	4				
14.3003.0.000	3-21	45	1	19.0095.1.405	3-51	36	4				
14.3004.0.000	3-21	25	(1)	22.0216.0.000	3-49	13	(1)				
14.3004.0.051	3-21	24	1	22.0217.0.000	3-49	09	(1)				
14.3005.0.000	3-21	42	1	22.0218.0.000	3-49	03	1				
14.3006.0.201	3-21	37	1								
14.3015.0.000	3-15	33	1								
14.3015.0.802	3-15	22	1								
14.3017.0.000	3-15	21	1								
14.3025.0.000	3-25	76	1								
14.3064.0.001	3-9	22	(1)								
14.3085.1.050	3-23	18	1								
14.3087.0.000	3-23	30	1								
14.3088.0.000	3-23	23	1								
14.3251.1.000	3-15	15	1								
14.4001.0.150											
14.4001.0.150	3-17	32	(1)								
14.4001.0.904	3-17	35	((1))								
14.4005.0.000	3-17	05	(1)								
14.4008.1.000	3-17	03	(1)								
14.4009.1.000	3-17	07	(1)								
14.4011.0.200	3-17	22	((1))								
14.4013.1.000	3-17	52	(1)								
14.4015.1.000	3-17	24	(1)								
14.4022.0.000	3-21	31	(1)								
14.4022.0.051	3-21	30	1								
14.4023.0.000	3-21	34	(1)								
14.4023.0.000	3-43	27	1								
14.4025.0.901	3-17	69	1								
14.4201.0.000	3-17	11	(1)								
14.5019.0.000	3-23	13	1								
14.5034.0.000	3-35	06	1								
14.8888.2.287	3-29	01	1								
14.9005.0.050	3-43	24	2								

Revised 10/2009

e-mail: service@amfreece.cz; parts@amfreece.cz; website: www.amfreece.com

Phones: +420 582 309 146 (Service), +420 582 309 286 (Spare Parts); Fax: +420 582 360 606