

Service Manual

Buttonhole and Label Sewing Machines

Series S3



MAINTENANCE AND TROUBLE SHOOTING

This Service Manual provides information on the Installation, Operation and Adjustments for all Reece series S3 machines. It has been compiled for the S3 Buttonhole machine, the basic model of the S3 series. Most adjustments for other models are covered in these basic instructions.

Special instructions are provided for other models where adjustments differ from or are in addition to the basic buttonhole machine instructions.

CONTENTS

S3 Machine Checking Adjustments

Needles

Parallel Installation	1
Crosswise Installation	2
Belt Installation	3
Solenoid Starting Unit	4
Threading	5
Operating Instructions — Basic	6-7
Operating Instructions — S3 Label Sewers	8-9
Operating Instructions — Combination Tacker	9
Needle Bar Timing	10
Needle Bar	11
Barring Cam	12
Clamp Plate Stopping Position	13
Feed Reversing Cam Brake	14
Feed Unit & Feed Screw	15
Feed Mechanism	16
Feed Shifter Timing	17
Braking	18
Cutting	19-21
Belt Size	21
Clamping	22
Stop Motion	23-24
Clutch	25
Stitch Bite	26
Related Looper & Needle Bar Settings	27-29
Cutting Space	30
Thread Handling	31
Trimming	32-34

S3 MACHINE CHECKING ADJUSTMENTS

The following check adjustments and the quick examination of machine parts establish that the S3 machine is in proper mechanical adjustment. Sewing adjustments may then be refined without being concerned that mechanical settings are causing interference.

CHECKING SEQUENCES	ADJUSTMENT	PAGES	FIG/MACHINE CHECKING FIG. (MC)
1	Needle Bar "Rock-over"	27	Fig. 3 & 4
2	Needle Bar Vibrator Cam	11	MC-2
3	Needle Bar Height	10	MC-3
4	Stitch Bite & Stitch Line	26	MC-4A & 4B
5	Centralizing Knife*	20	MC-5A & 5B
6	Thread Take-up. Recheck when sewing	31	MC-6
7	Thread Trimming	32-34	MC-7A & 7B
8	Stop Motion Adjustment	23 & 24	MC-8A, 8B, 8C
9	Barring Cam*	12	MC-9
10	Side Clearance*	11	MC-10A, 10B
11	Center Stopping for Cutting*	19	MC-11
12	Feed Shifter Timing	17	MC-12A, 12B
13	Clamp Plate Stopping Position	13	MC-13A, 13B, 13C, 13D
14	Looper and Needle Bar	27 & 28	Fig. 5 thru 10
15	Looper and Needle Bar	29	Fig. 11-16
16	Recheck adjustment #6	—	—

* Buttonhole Machine Only

NEEDLES

Needles for the Reece Series S3 Machines are packaged and sold in boxes of 100, in the sizes and types listed. They are of superior struck groove construction, chrome plated and are spotted at the eye except in sizes 00 and finer. When ordering, specify quantity — (100, 200, etc.) and give the Needle E.D.P. Number.

TYPE	APPLICATION	E.D.P. NUMBER	CODE NUMBER	NEEDLE BLADE SIZE
ROUND POINT LONG SHANK	Applicable to the majority of woven fabrics, knits and materials of similar consistency. These needles have a long shank that gives added stiffness to the blade permitting the use of one size smaller needle than would be normally required. Cannot be used on heavy materials that would be penetrated by the tapered portion of the needle's shank.	02-0750-1-400 02-0750-1-000 02-0750-1-000	750-LS-0000 750-LS-000 750-LS-00	Extremely Fine Extra Fine Very Fine
ROUND POINT	Applicable to the majority of woven fabrics, knits and materials of similar consistency.	02-0750-0-110 02-0750-0-111 02-0750-0-112	750-0 750-1 750-2	Fine Medium Heavy
BALL POINT LONG SHANK	Applicable to tightly woven or knitted fabrics, particularly silks and synthetics when the fibers of the materials are subject to damage or fracture by conventional Round Point needles. The Long Shank of this needle gives it the advantages stated for Round Point Shank needles.	02-0751-1-400 02-0751-1-000 02-0751-1-000	751-LS-0000 751-LS-000 751-LS-00	Extremely Fine Extra Fine Very Fine
BALL POINT	Same application as the Long shank Ball Point needle above.	02-0751-0-110 02-0751-0-111	751-0 751-1	Fine Medium
SPEAR POINT	Applicable to fabrics containing a high percentage of starch or similar substances that tend to cause needle heating or resistance to proper pulling up of the stitches.	02-0752-0-110 02-0752-0-111 02-0742-0-112	752-0 752-1 752-2	Fine Medium Heavy
SPEAR POINT DOUBLE GROOVE	The Double Groove needle should be used only when the conditions justify it because it casts a smaller loop than standard needles and may introduce skipping. For this reason looper points should be set close to the needle blade. This needle is used on materials that have a tendency to trap the thread in its descent into the work which affects the thread take-up, or causes the thread to break at the needle's eye.	02-0752-0-211 02-0752-0-212	752-1-DG 752-2-DG	Medium Heavy
CROSS POINT LONG SHANK	Applicable to fine leather and similar materials as well as some types of plastics where conventional needles tend to leave excessive punctures. This needle permits a higher stitch density than Round Point needle. There may be a tendency in some cases, for the materials to cling to this needle, therefore, it should be used only after comparative test with other needles. The Long Shank of this needle gives it the advantages stated for Round Point Long Shank needles.	02-0752-1-100	753-LS-00	Very Fine
CROSS POINT	The same applications as the Cross Point Long Shank needle above.	02-0753-0-110 02-0753-0-111 02-0753-0-112	753-0 753-1 753-2	Fine Medium Heavy
ROCKED POINT	Applicable to leather and similar materials where conventional sharp pointed needles tend to leave excessive punctures. The slit made by the Rocked Point needle will tend to close up after penetration. This needle permits a higher stitch density than is possible in leather with a round point needle.	02-0754-0-110 02-0754-0-111	754-0 754-1	Fine Medium

PARALLEL INSTALLATION

1. Accessory box, supplied with machine, contains all necessary items for installation.

2. Make sure that motor specifications are correct for electrical supply and that the Motor Pulley rotates in direction of arrow.

3. Locate machine on table as shown and outline its position in pencil.

4. Install machine base to table with 4 screws. As shown in figure, install rubber bushing mounts from both sides of table to each of the four holes by inserting metal bushing and then insert four screws with washers and spring washers from under the table and screw into the holes at corners of machine base.

5. Connect lower end of Short Chain (D) to Lever (E). Tip machine back on its hinges and press Shifter Lever (C) inward until Pin (B) contacts the Machine Base as shown. While maintaining this position, adjust Screw (G) so that a slight amount of slack exists in Chain (D).

6. Attach Long Chain (J) to Lever (A) and let it hang vertically.

7. Place Pedal (K) on Rail as shown so that left side of Pedal is in alignment with vertically suspended Chain (J). Then attach the Pedal (K) to rail of table using wood block and screws provided in accessory box.

8. Attach Long Chain (J) to Pedal so that toe of pedal is approximately 5" above floor.

9. Install Belt and adjust belt tension by loosening Screws (H) and (L) and turning Screw (F) to right or left as required. **IMPORTANT:** A reasonably tight belt tension should be maintained at all times and new belts should be tightened frequently during their initial stretching period.

10. Start machine in accordance with the Operating Instructions, Pages 6 and 7. For adjustments of Machine Starting and Stopping Mechanisms, refer to Pages 23, 24 and 25.

NOTE 1: Motor is equipped with a manual reset overload protector. If the motor stops because of overloading, allow motor to return to normal temperature and then press red reset button on motor.

NOTE 2: See Belt Installation on Page 3.

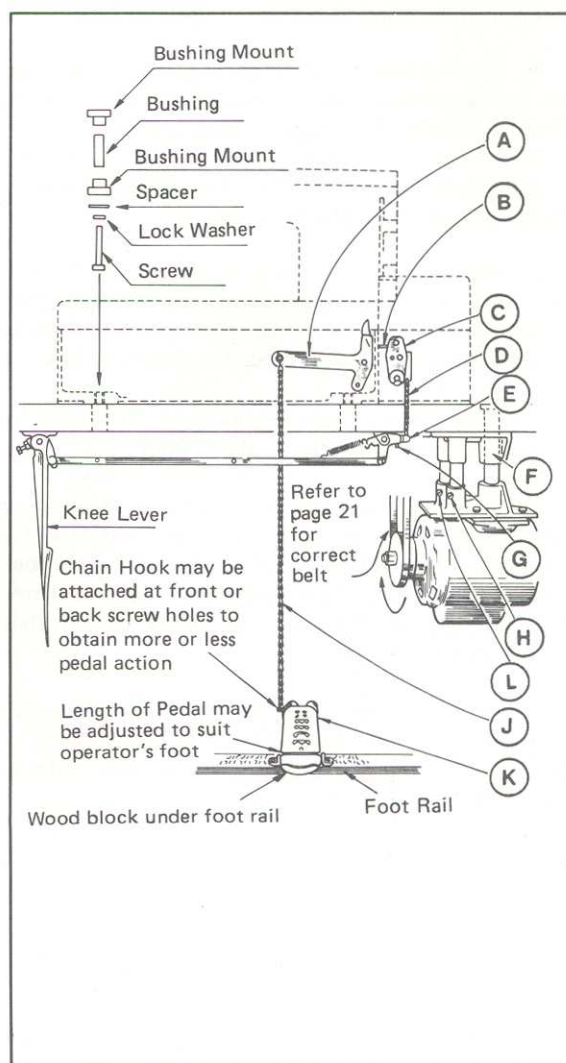
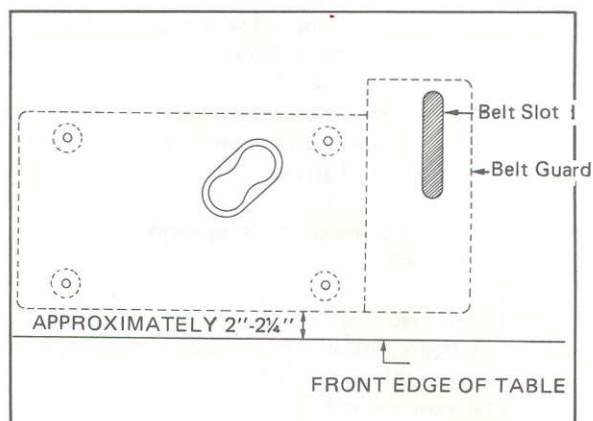

CROSSWISE INSTALLATION

1. Accessory box, supplied with machine, contains all necessary items for installation.

2. Make sure that motor specifications are correct for electrical supply, and that the Motor Pulley rotates in direction of arrow.

3. Locate machine on table as shown and outline position in pencil.

4. Install machine base to table with 4 screws. As shown in figure, install rubber bushing mounts from both sides of table to each of the four holes by inserting metal bushing and then insert four screws with washers and spring washers from under the table and screw into the holes at corners of machine base.

5. Connect lower end of Short Chain (F) to Lever (H) and adjust Screw (G) to allow slack to exist in the Chain as described on Page 1, paragraph 5.

6. Attach Long Chain (E) to Lever (D) and let it hang vertically through chain hole.

7. Place Pedal (J) on Rail as shown, so that left side of Pedal is in alignment with vertically suspended Chain (E). Then attach Pedal (J) to rail of table using wood block and screws provided in accessory box.

8. Attach Long Chain (E) to Pedal (J) so that toe of Pedal is approximately 5" above floor.

9. Install Belt and adjust belt tension by loosening (A) and (C) and turning Screw (B) to right or left as required. **IMPORTANT:** A reasonably tight belt tension should be maintained at all times and new belts should be tightened frequently during their initial stretching period.

10. Start machine in accordance with the Operating Instructions, Pages 6 and 7. For adjustments of Machine Starting and Stopping Mechanisms, refer to Pages 23, 24 and 25.

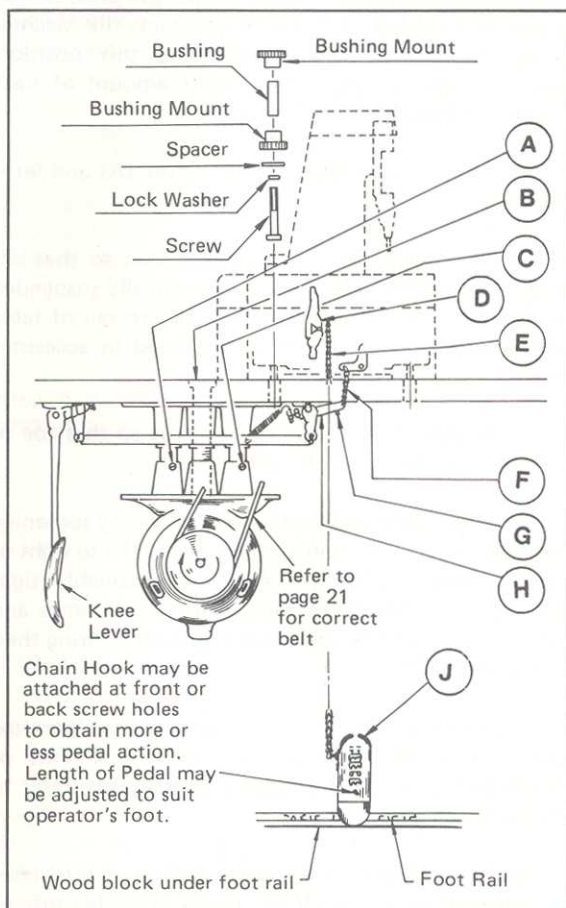
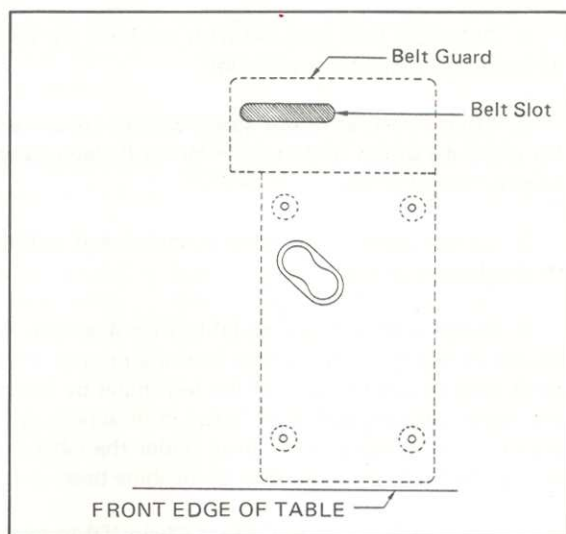

BELT INSTALLATION

1. Tip machine back for installing belt. To tip machine, move Clutch Ring (A) to the left until it hooks on to Spring (D) of Driving Pulley (C) and lock. In this condition, Clutch pawl is released and machine can be tipped freely.

2. To install belt, first loosen Clutch Pulley Shaft Screw (F), push Pulley Shaft (G) toward left and remove together with V-Pulley. After placing V-Belt into V-Pulley belt groove, insert Pulley Shaft into hole on Clutch Pulley Shaft Bracket (H) and tighten Clutch Pulley Shaft Screw (F). When tightening screw (F), strongly press shaft to right. If it not pressed sufficiently, there will be axial play in V-Pulley (E) and will be causes for noise and also shortening of machine life.

3. Restore machine to original position and engage Clutch Ring (A) with pawl of Clutch Cone (B). In case proper engagement can not be obtained, rotate Clutch Cone (B) by slightly turning V-Pulley (E) until pawl comes to proper position, then move Clutch Ring (A) toward right for proper engagement.

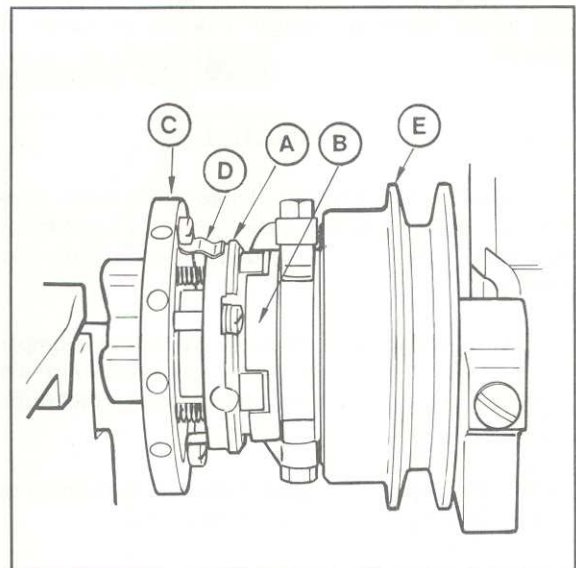
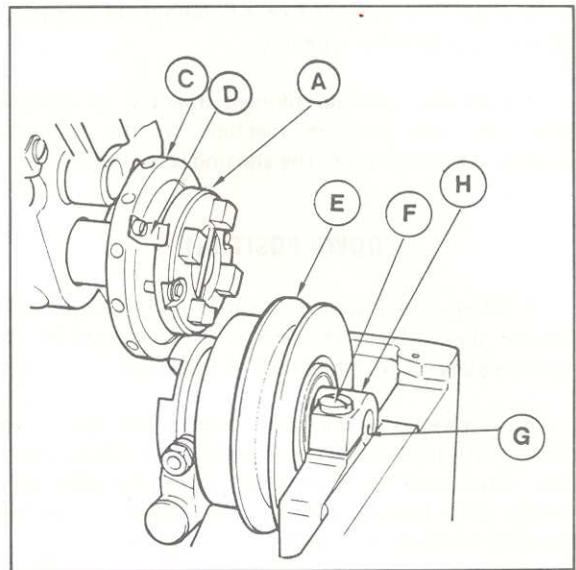

SOLENOID STARTING UNIT

1. Pour 14 ounces of Reece Solenoid Oil (contents of can) into breather opening.

2. Connect solenoid plunger link (A) to starting lever (B) and position machine so the solenoid plunger is vertical when the starting lever is up.

DOWN POSITION

1. When the machine is operated, the stop bolt holder should clear the side of the bed plate by approximately .005" (thickness of this page).

2. To check this clearance, release belt, then, turn power on—hold pushbutton switch on top of relay box down and press pedal to move the stop bolt holder into starting position. The .005" should be checked at point indicated.

3. To adjust the clearance, remove lever pin (A), and screw solenoid plunger link up or down as desired.

UP POSITION

1. Depress the solenoid plunger to its down position, and sighting with a scale against the top edge of the base, check 1-1/8" plunger rise to the top position.

2. If adjustment is necessary, reposition bumper (D), for the 1-1/8" rise. This movement limits the stroke of the solenoid core to avoid contact with the top of its housing.

NOTE: The 1-1/8" upward movement establishes the correct position for starting arm (C).

3. Attach belt.

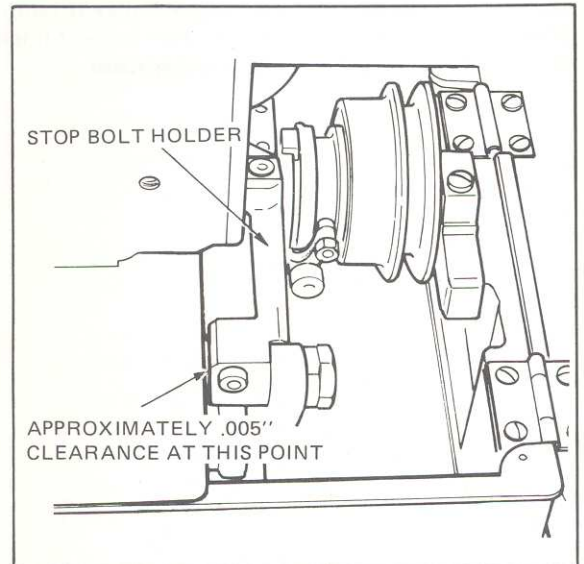
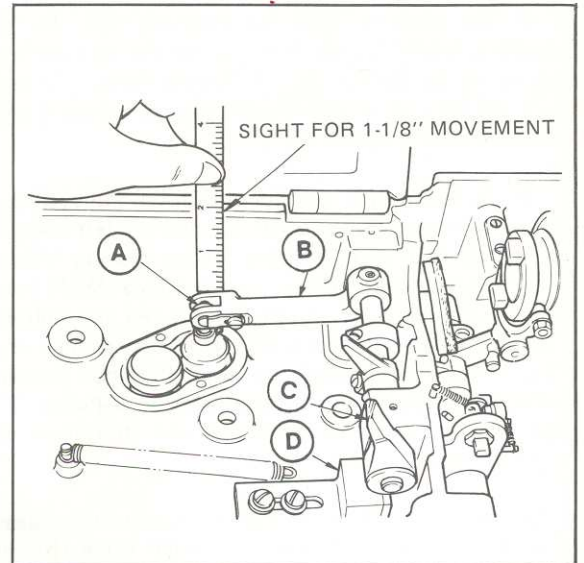

THREADING

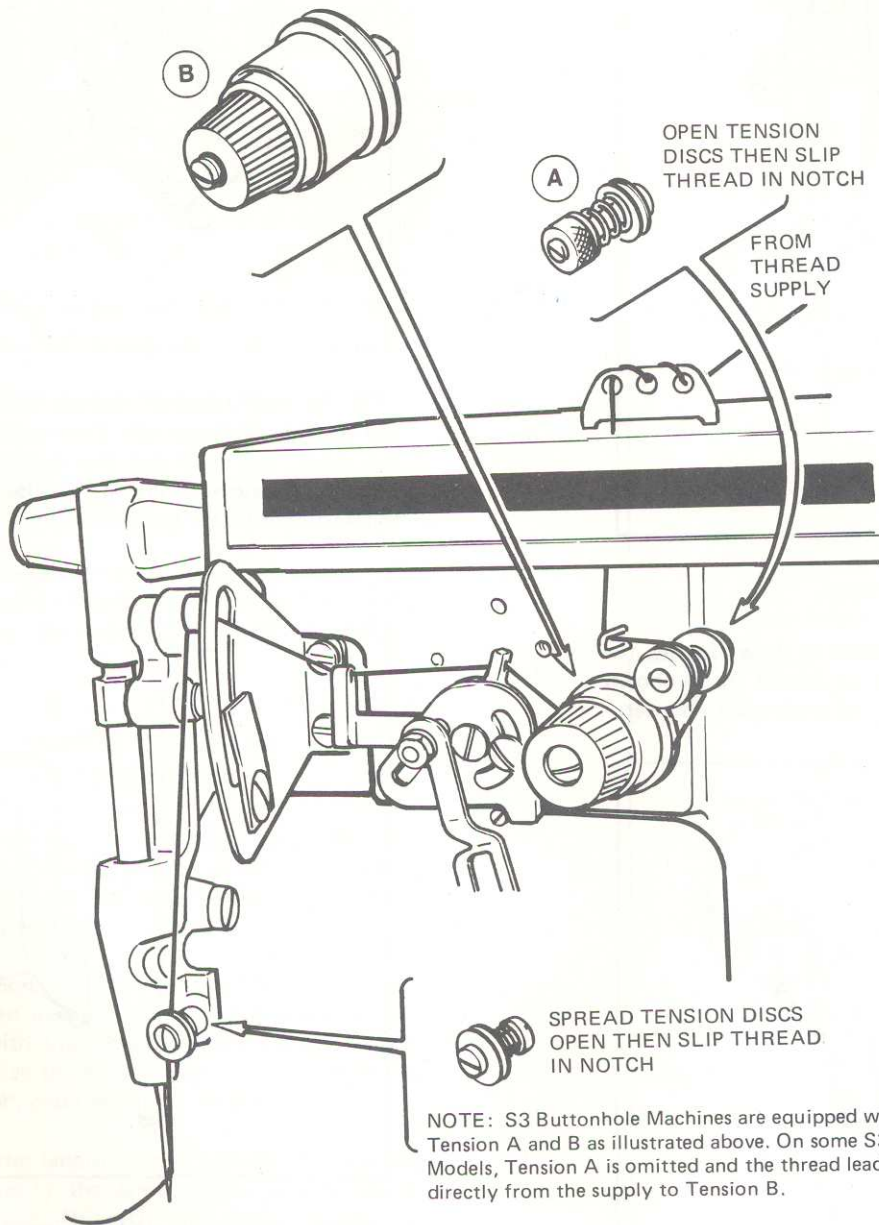

OPERATING INSTRUCTIONS

1. Make sure that the needle is straight and that it is set as high as it will go in the Needle Bar with the flat spot on the shank facing the Needle Screw.

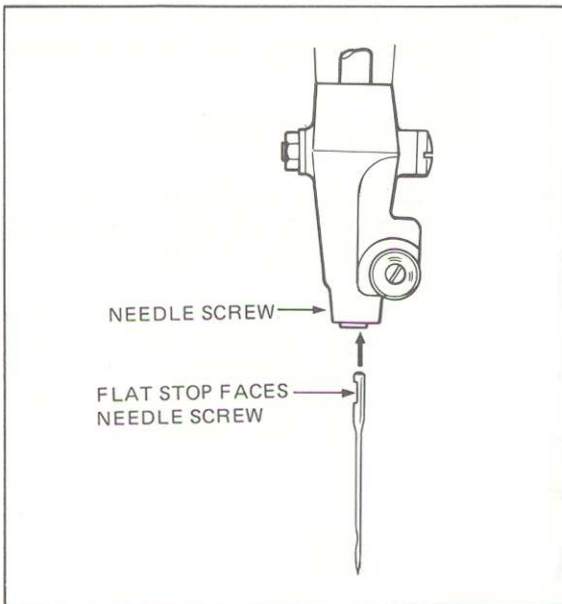

2. Turn motor on to start belt.

3. Insert work under Clamps as shown below, for sewing buttonholes parallel to border or as shown opposite for sewing buttonholes crosswise to border.

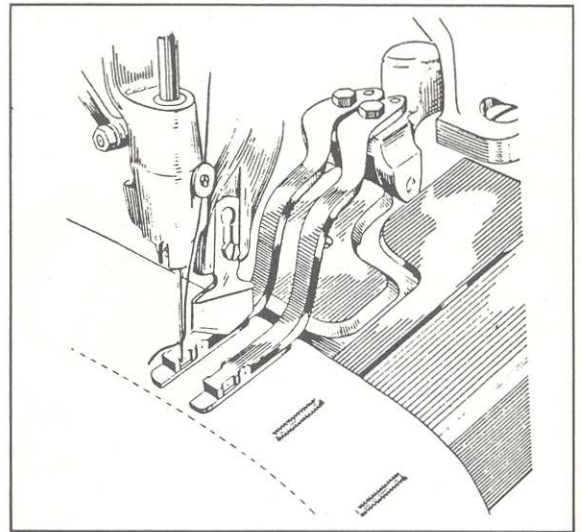
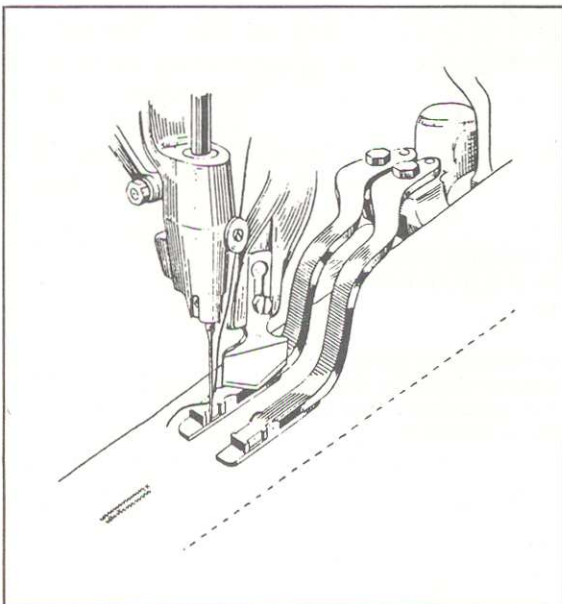

4. To start machine, depress starting pedal to its full extent. Machine will then automatically clamp the work, sew and cut the buttonhole, trim the thread and stop with clamps in raised position ready for starting the next buttonhole.

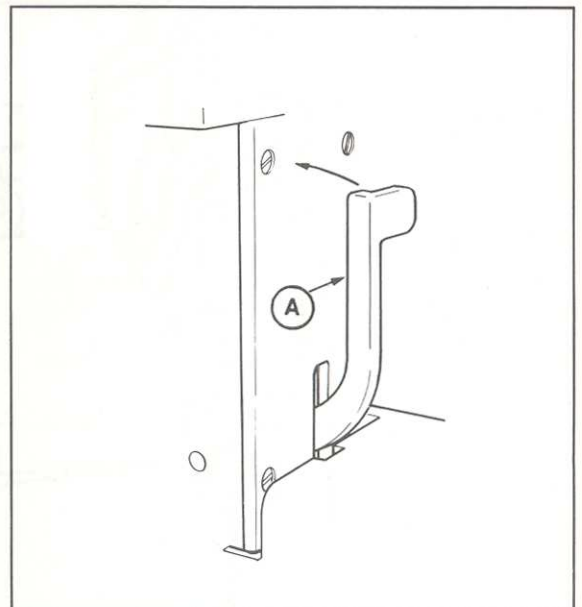

NOTE: The work can be clamped before starting the machine by partially depressing the pedal.* The clamps can also be raised at any time for removal or adjustment of the work by pressing Unclamping Handle (A) in direction of arrow, as shown opposite.

* On Solenoid equipped tables, the Knee Lever must be held to the side as the Pedal is pressed. To restart, follow directions on Page 7, detail 5.

OPERATING INSTRUCTIONS

CUTTING OPERATIONS

EMERGENCY STOPPING

In the event of any emergency such as thread or needle breakage, which necessitates removal of the work from the machine, proceed as follows.

1. Quickly press Knee Lever to the left to stop the machine.
2. Turn Drive Pulley with Pin Wrench to raise the needle out of the work.
3. Raise Clamps by pressing Lever (A) in direction of the arrow and remove work from machine.
4. Inspect Needle and replace with new one if bent or damaged.
5. Restart machine by depressing pedal. Then allow machine to operate to normal stopping position.
6. Rethread the Needle and re sew the buttonhole after reinserting the work in the original position under the Clamps.

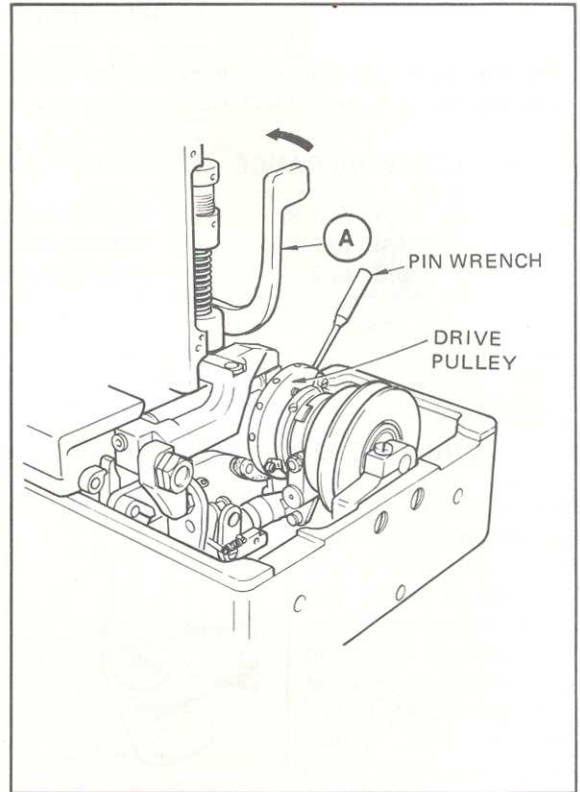

TO CHANGE LENGTH OF BUTTONHOLES

1. Tip machine back on its hinges. Loosen Nut (G) and slide Plate (F) until Pointer is opposite the size desired as shown on the Length Gauge (C). Then tighten Nut (G) securely.

2. Loosen Screw (H) and remove Knife from Cutting Lever. Then install Knife with size marking that corresponds with that chosen on the Length Gauge. Be sure that size marking on the Knife faces in the direction shown, and tighten (H) securely.

NOTE: If the length of the buttonhole does not measure exactly the same as the Length Gauge setting, loosen Nut (D) and adjust Screw (E) inward or outward as required until the length of the buttonhole corresponds with the gauge setting. When this adjustment has been established for one size buttonhole, the sizes of all buttonholes will correspond with the settings of the Length Gauge.

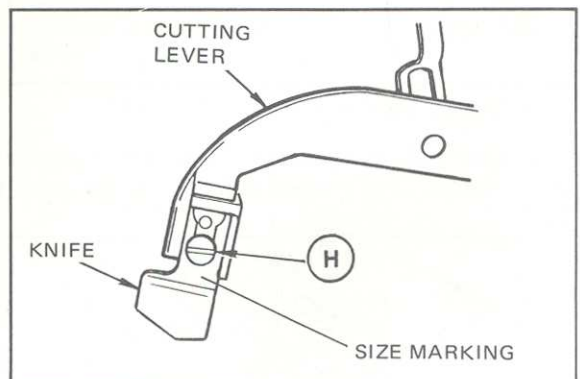
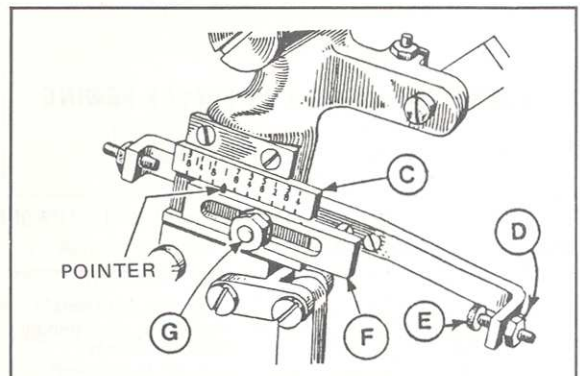

OPERATING INSTRUCTIONS

S3 LABEL SEWER – MODEL S3-LS2N – RANGE 1/4"–2"

For maximum operating efficiency use the shortest Clamp Arm, Clamp Foot and Adjustable Slide, listed below, for the shortest sewing range that will accommodate your labels.

SEWING RANGE	CLAMP FOOT	CLAMP ARM	ADJUSTABLE SLIDE
1/4" to 7/8"	20-0650-0-406	20-0649-1-405	20-0240-0-405
1/4" to 1 1/2"	20-0650-0-606	20-0649-1-605	20-0240-0-605
5/8" to 2"	20-0650-0-706	20-0649-0-705	20-0240-0-705

SINGLE OR TWO ROW STITCHING

The machine may be operated for either single sewing or double sewing each end of a label. For single sewing operation, tip machine back and swing shifter, pictured at the right, DOWN to "S" position. For double sewing operation, swing Shifter Up to "D" position.

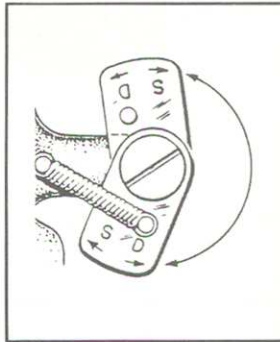

WORK HANDLING FOR SINGLE SEWING

1. Start with Clamp in back position.
2. Position label on garment and slide straight back under clamp to position.

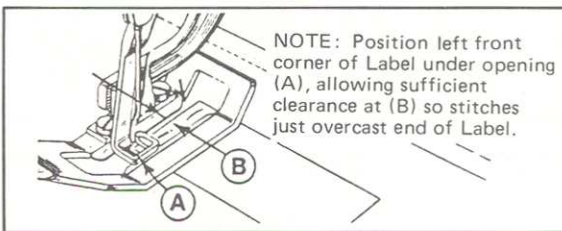

3. Depress pedal to sew left end of label.
4. Shift label and garment straight left to position shown below. Then depress pedal to sew right end of label.

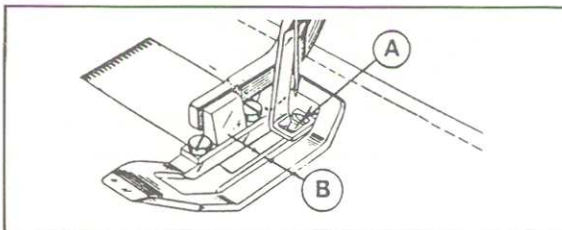

WORK HANDLING FOR DOUBLE SEWING

1. Sew one operation on scrap material to make sure clamp is forward.
2. Position label on garment and slide straight back under clamp to position shown.

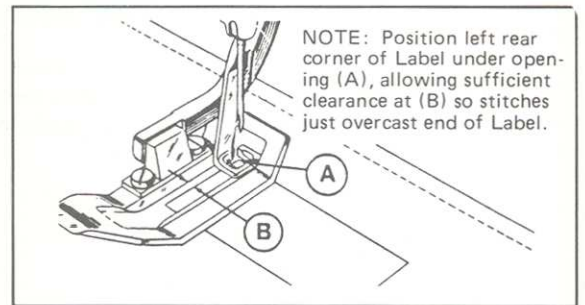

3. Depress pedal to sew left end of label.
4. Shift label and garment straight left to position shown below. Then depress pedal to sew right end of label.

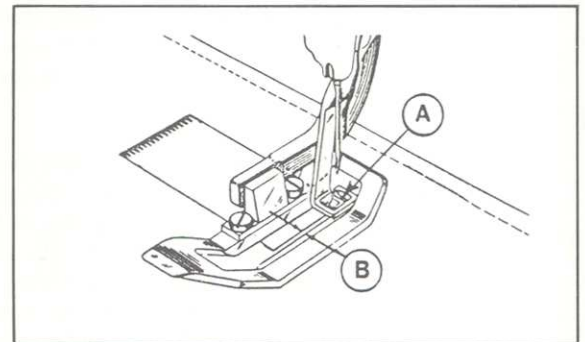

NOTE: The described work movements carry thread into the opening of the Clamp Foot for the first sewing operation, and into the groove at the rear of the Clamp Foot for the second operation, thus leaving the thread ends free to be consumed in the stitching.

OPERATING INSTRUCTIONS

S3 – COMBINATION REGULAR & DOT TACKERS Models S3-TRWD & S3-SRWD INSTRUCTIONS FOR CHANGING LENGTH & WIDTH OF TACKS

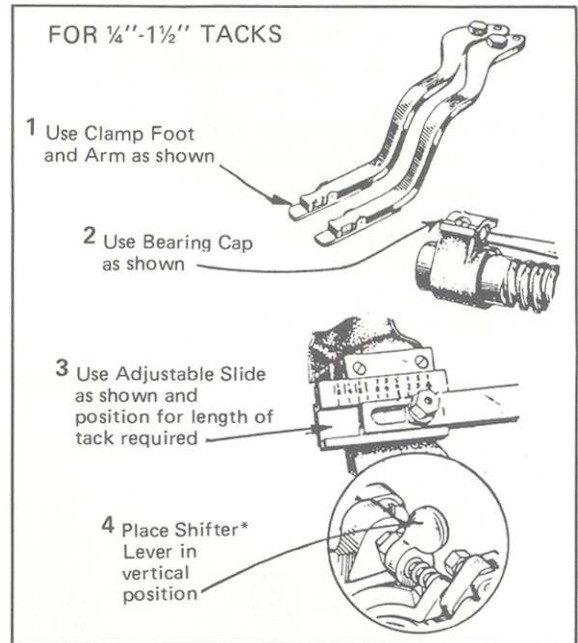
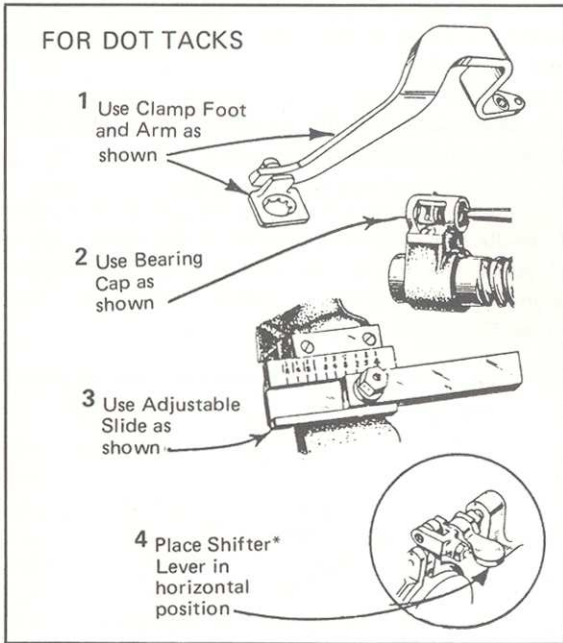

* Groove on special nut (01-3432) must be in a vertical position for proper Step #4 alignment.

MACHINES MUST BE IN NORMAL STOP POSITION WHEN MAKING CHANGES LISTED BELOW (FOR BOTH DOT TACKING AND REGULAR TACKING)

TO ADJUST WIDTH OF STITCH (Stitch Bite) FOR NARROW STITCH BITE

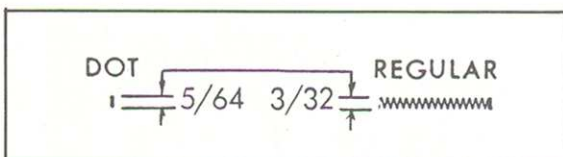

1. Loosen Screw (A) and turn in Screw (B) to eliminate all clamp vibration, making sure that there is a slight clearance between Mat and Throat Plate at (X).

2. Adjust Stitch Bite as shown on page 26 of the S3 Service Manual, Maintenance and Troubleshooting Section. Also, adjust Loopers as described on pages 27-29 of the same manual.

FOR WIDE STITCH BITE

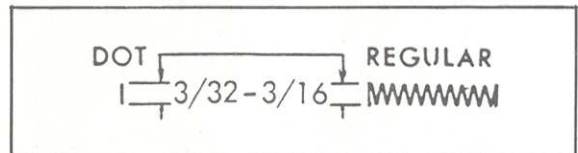

1. Adjust the Stitch Bite and Loopers for 3/32" bite, as described on page 26 of the S3 Service Manual, Maintenance and Troubleshooting Section. Also, adjust Loopers as described on pages 27-29 of the same manual.

2. Turn Screw (B) out until the desired bite is obtained.

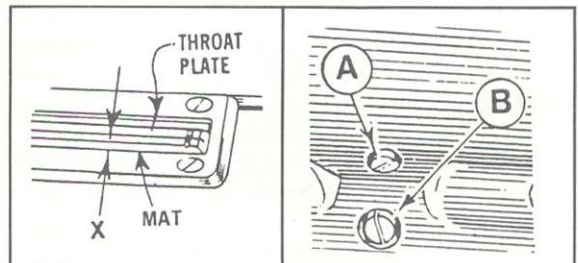

CAUTION: Whenever the Stitch Bite is changed, turn the machine through by hand to be sure that the Needle clears the Clamps.

NEEDLE BAR TIMING

GEAR ASSEMBLY

1. In the event that gears are disassembled, they should be reassembled with the mark on the tooth of the Large Gear (B), shown at right, directly in line with the mark on the Counter Balance at (A).

NOTE: Since the gear ratio is 2 to 1 the marks will line up only once for every two revolutions of the small gear.

When marks are lined up, the two set screws at (F) are accessible for adjustment of Rock-Over in machine stop position.

See adjustment 3, page 27.

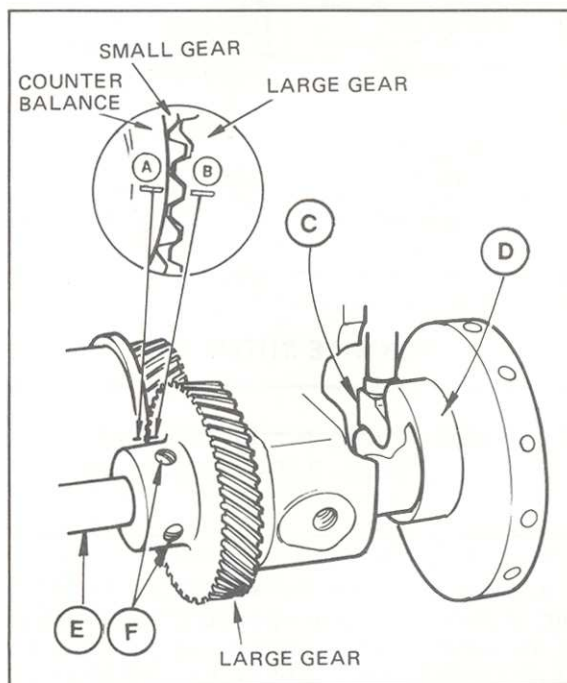

GEAR ADJUSTMENT FOR NEEDLE BAR TIMING

1. Make sure that the Stop Bolt (C) is in the recess of Cam (D) as shown. This is the Machine's normal stopping position.

2. Loosen two set screws (F), and turn Large Gear on Shaft (E) until the Needle Bar, shown at right, is at the highest point of its stroke. While maintaining this position, tighten lightly screws (F), then adjust Large Gear sidewise as required until a very slight amount of end play (.001-.002) exists in the main shaft. Then tighten screws (F) securely.

NEEDLE BAR HEIGHT ADJUSTMENT

1. Make sure that the machine is in its normal stopping position as described above – (Gear adjustment – Item 1).

2. Make sure that the Needle is set as high as it will go in the Needle Bar (G).

3. Loosen Set Screw (H) at right and adjust height of Needle Bar so that the center of the needle eye is $\frac{1}{2}$ " above the top of the Throat Plate. Use Needle Height Gauge 03-0050 in manner illustrated. Then tighten Screw (H) securely.

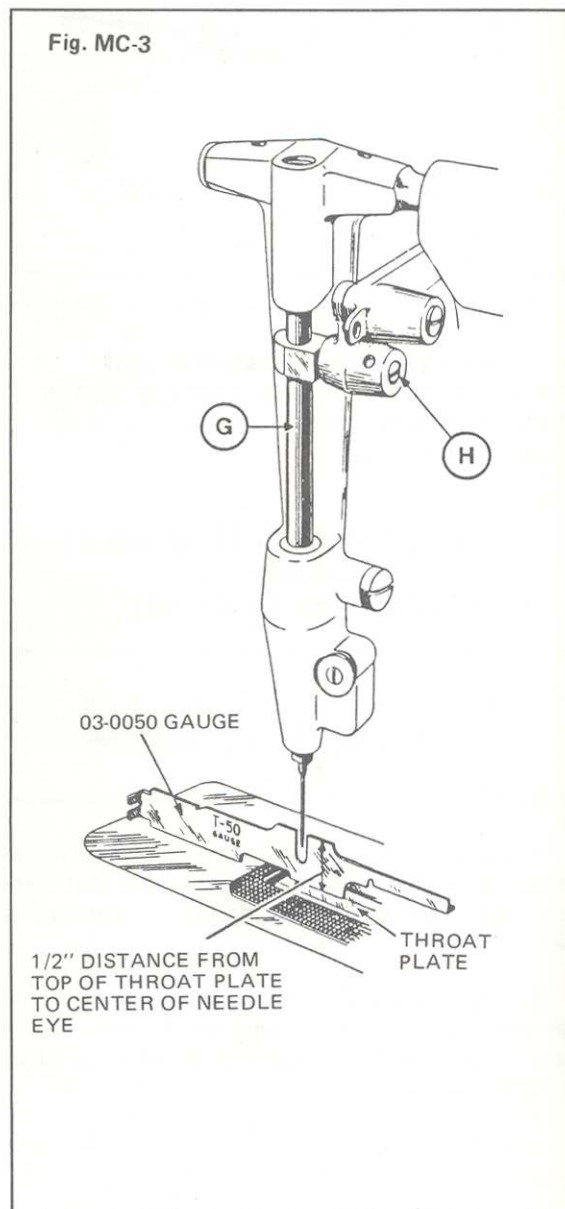

NEEDLE BAR TIMING

TO SET NEEDLE BAR VIBRATOR CAM

1. Position Needle Bar Vibrator Cam (A) so that Screw (D) faces the flat spot on Shaft (B). After the proper location has been obtained tighten Screws (C) and (D) securely.

NOTE: When this setting has been correctly established, the end of Latch (E) will be approximately 1/8" from the second notch in Cam (A) as shown, which is its normal stopping position.

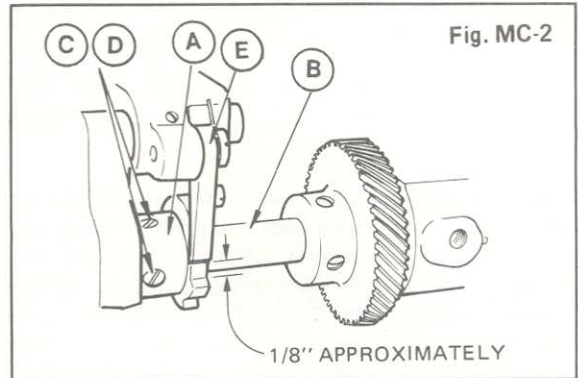

MAT AND THROAT PLATE SIDE CLEARANCE (For Buttonhole Machines only)

1. Press Stop Bolt Shaft (G) inward to latch machine in sewing position so that Drive Pulley (F) will be free to turn. Tip machine back on its hinges and press Shifter Lever (H) to the right to place the machine in Feed reversing position. Then turn Drive Pulley with Pin Wrench until Barring Cam starts to turn. Stop turning when Roll (P) is on top of one of the five high lobes of the Barring Cam as illustrated. (Also see note)

2. Loosen Screws (I), (J), (N) and (O) and set the position of Adjustable Yoke (M) so that approximately 1/64" clearance exists between the edge of the Clamping Mat and the rear edge of Throat Plate as shown. While maintaining this position, tighten Screws (N) and (O) securely. Then position Overthrow Stop (K) to lightly contact Stud (L) and tighten Screws (I) and (J).

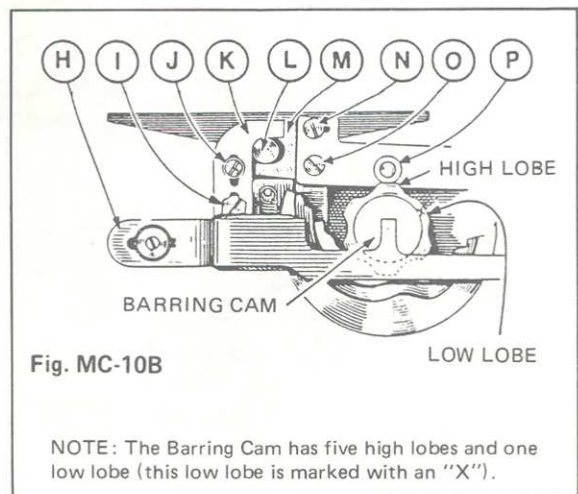
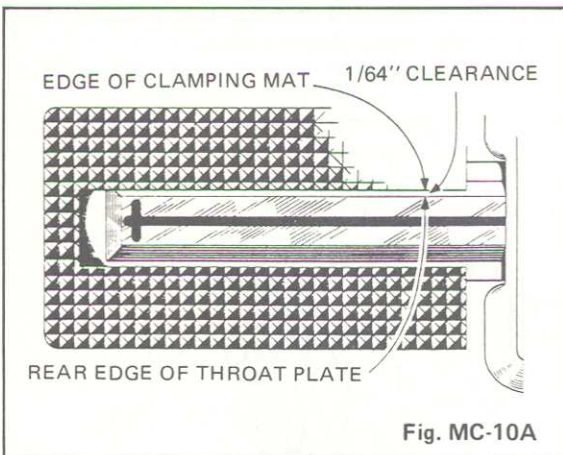
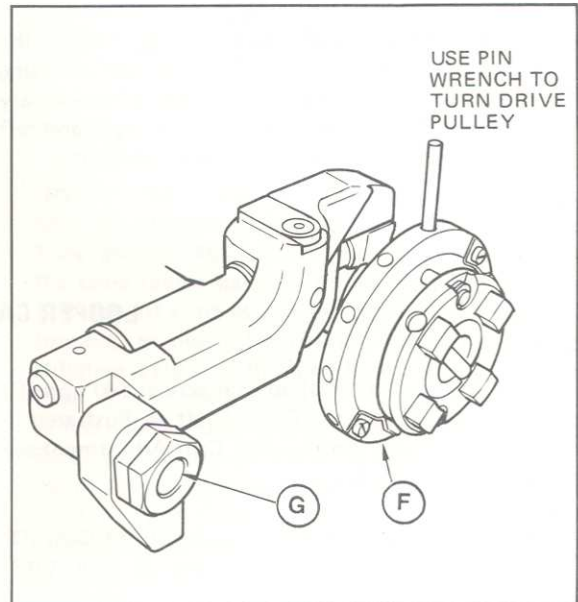

3. Turn Drive Pulley with Pin Wrench until machine locks in normal stopping position.

BARRING CAM

BARRING CAM ADJUSTMENT FOR BUTTONHOLE MACHINES, WIDE BITE TACKERS AND COLLAR STAY TACKERS. FOR ALL OTHER TACKERS, LABEL SEWERS AND EDGERS, SEE PAGE 24.

Start machine and stop it while sewing the first row of stitches. Tip machine back and press Shifting Lever (G) to the right to reverse the feed. Then turn Drive Pulley slowly with Pin Wrench and observe the barring movement of the Clamp Plate in relation to the needle position. When the needle is rising on its front stroke the Clamp Plate should start to shift in direction X just as the eye of the needle emerges from the hole in the Throat Plate. (See detail.) If adjustment is necessary, loosen Screws (E) and (F) and turn Gear (H) in either direction as required to obtain the above described result. Then press Gear (H) against Collar (I) and tighten Screws (E) and (F) securely.

NOTE: If the barring action stops before the above adjustment is completed, the feed reversing action can be repeated as many times as necessary by alternately shifting Lever (G) to right and left while keeping the machine in sewing position.

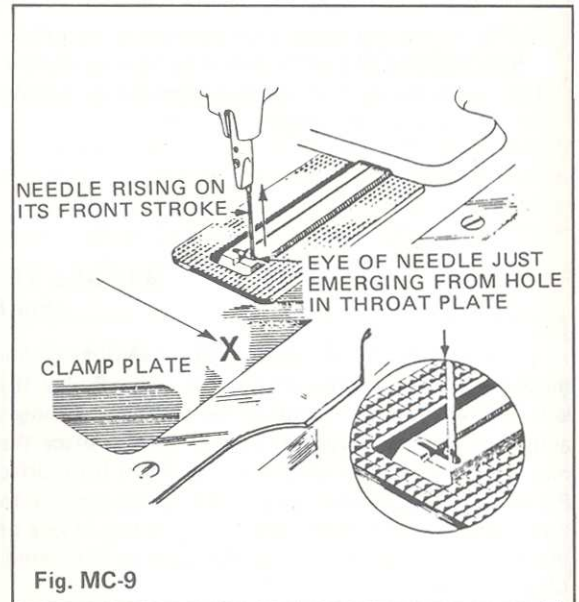

LOOPER CAM ASSEMBLY ON DRIVE SHAFT

Position Looper Cam (D) so that screws (A) and (C) enter the groove on the Drive Shaft as illustrated in cross section view. For Looper Cam Adjustment see page 28, paragraph 7.

NOTE: In the event that disassembly of Cam (D) from the machine is necessary at any time,

proceed as follows. Loosen screws on the various shaft members between the Feed Drive Gear and Drive Pulley, and move the shaft a sufficient distance to the right to permit removal of Cam (D). To reassemble, reverse this procedure and retime the various shaft members.

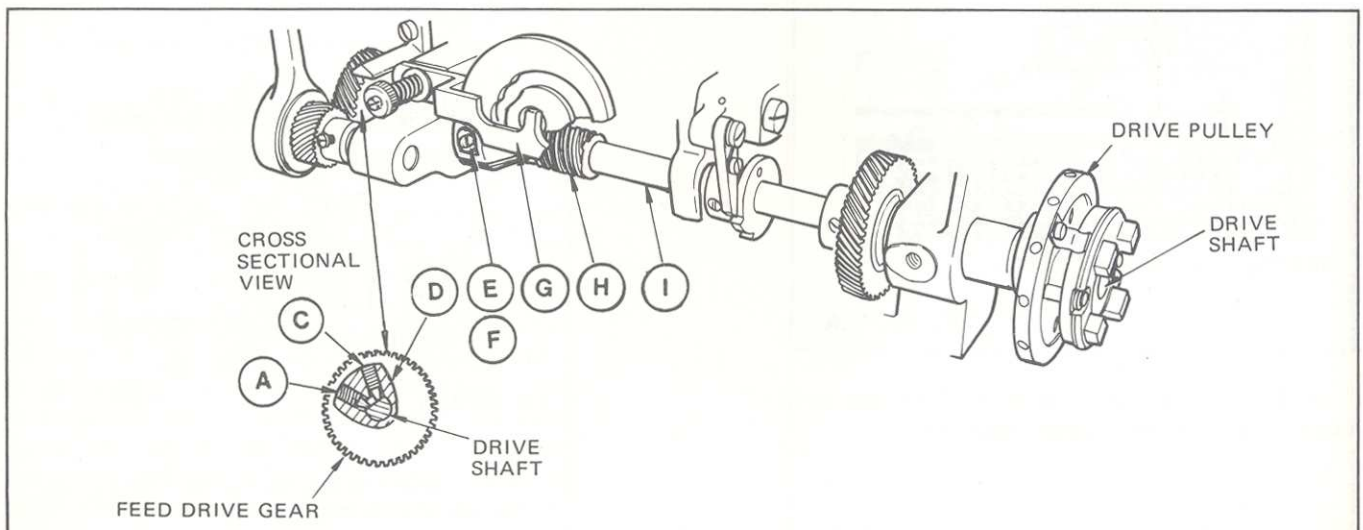

CLAMP PLATE STOPPING POSITION

TO ADJUST CLAMP PLATE STOPPING POSITION TO END OF THROAT PLATE

1. Operate machine to a point where the end of the Mat at (A) is approaching close to the end of the Throat Plate at (B). Then turn Drive Pulley until the clearance between points (A) and (B) is approximately $1/32''$. With the Clamp Plate in this position, tip machine back on its hinges. Then loosen two Screws (G) and Nut (E). Back out Screw (D) to the limit. Move Bumper (H) in or out until it lightly contacts boss (C) of the cup on the Clamp Plate. Tighten Set Screws (G) securely. Adjust Screw (D) to contact the Bed Plate at (F) and tighten Nut (E) securely.

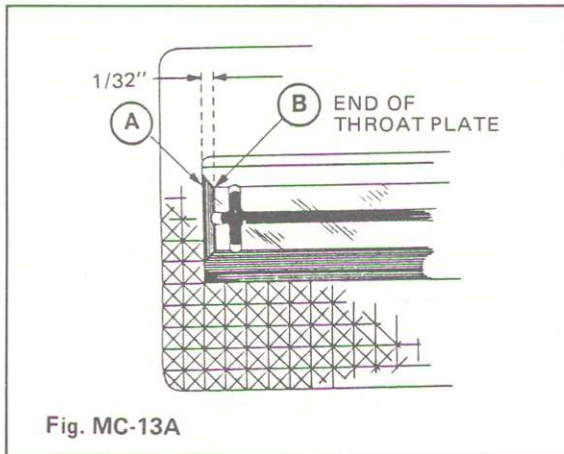

2. When Bumper (H) has been adjusted as described above, the forward movement of the Clamp Plate is blocked. Therefore, the feed reversing and barring action must be timed to occur at this point. To make this adjustment, proceed as follows: With the Clamp Plate still in the position described in item 1, loosen Nut (I) and adjust Screw (J) against Arm (K) so that Pawl (L) overlaps the extension of Shifting Lever by approximately $1/64''$. Then hold Screw (J) with screwdriver and tighten Nut (I) securely.

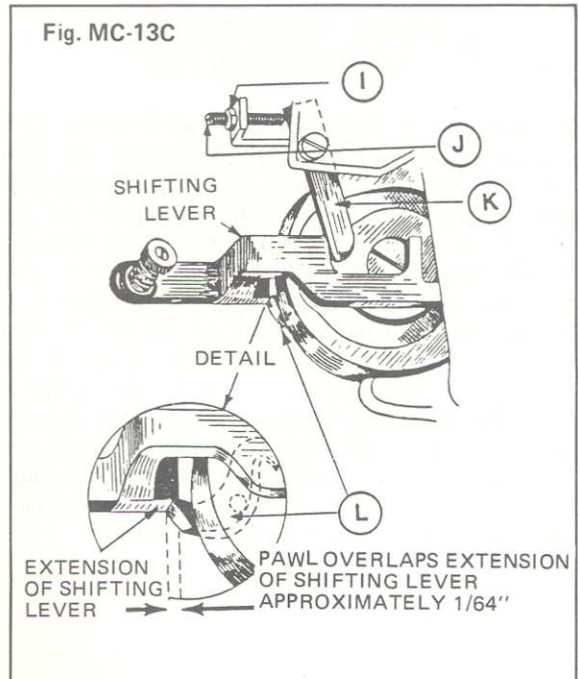
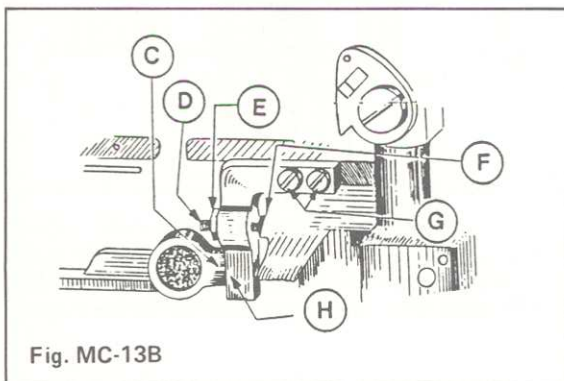

NOTE: The function of Bumper (H) is to maintain the relation between the end of the Throat Plate and the Mat at the stopping point, and by the same token maintain the relation between the first row of stitches and the front bar of the buttonhole, as illustrated below. If any gap in the stitching exists at this point, the engagement of Pawl (L) on the extension of the Shifting Lever is too short and should be increased by adjusting Screw (J) slightly outward. If there is any crowding of the row stitches at the front bar, the engagement of Pawl (L) is excessive and should be decreased by adjusting Screw (J) slightly inward.

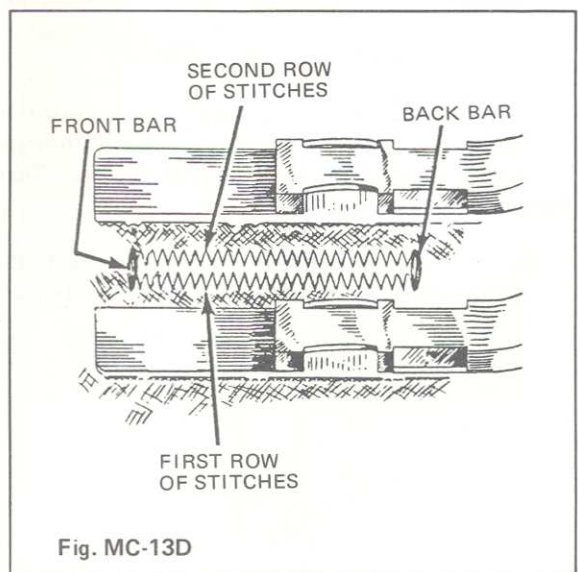

FEED REVERSING CAM BRAKE

BRAKE ADJUSTMENT ON FEED REVERSING CAM

The pressure of Brake (E) on Feed Reversing Cam (D) should be just sufficient to prevent the Cam from moving after it comes to a stop at the end of each barring cycle. At this time, Pawl (C) on the reverse side of the Cam will be held away from the Ratchet (B). Should the brake pressure be too light, the Cam will reverse slightly under the influence of Spring (A). This will permit Pawl (C) and Ratchet (B) to contact each other intermittently during the entire cycle instead of just during the barring operation. To adjust the brake pressure, loosen Nut (F) and adjust Screw (G) inward for more pressure and outward for less pressure until the point of minimum pressure is reached at which Cam (D) will remain stationary at the end of each barring cycle.

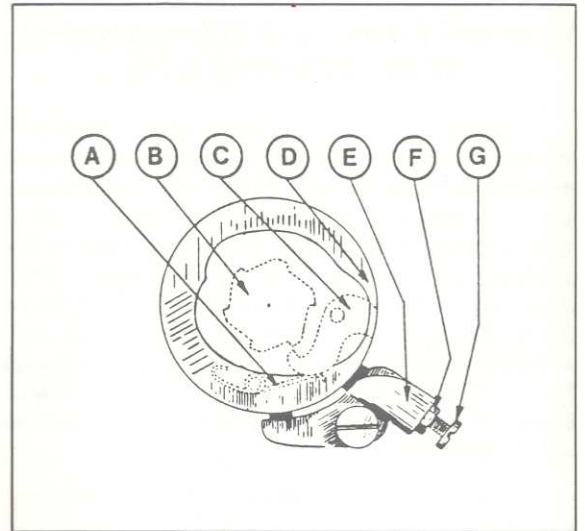

SHIFTING LEVER FRICTION ADJUSTMENT

Friction is applied to Shifting Lever (I) by means of the spring and washer under Knurled Nut (H). This is to prevent the Shifting Lever from moving except when actuated to reverse the clamp feed at each barring position. Knurled Nut (H) should be adjusted to provide the minimum friction on Lever (I) to permit the machine to operate without reversing the feed, or from barring at position other than at ends of buttonhole. Neoprene washer should be kept clean and fairly free of oil.

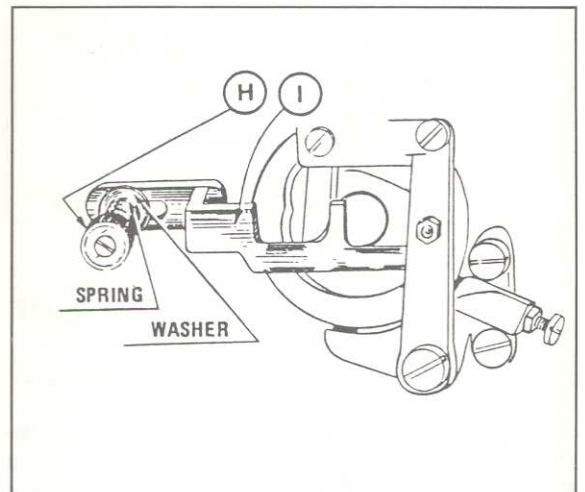

TO ADJUST STITCH DENSITY

Loosen Nut (J) and move Lever (K) outward to increase the number of stitches in the buttonhole or inward to decrease the number of stitches. Then tighten Nut (J) securely.

NOTE: The adjustment does not affect the number of stitches in the end bars of the buttonholes.

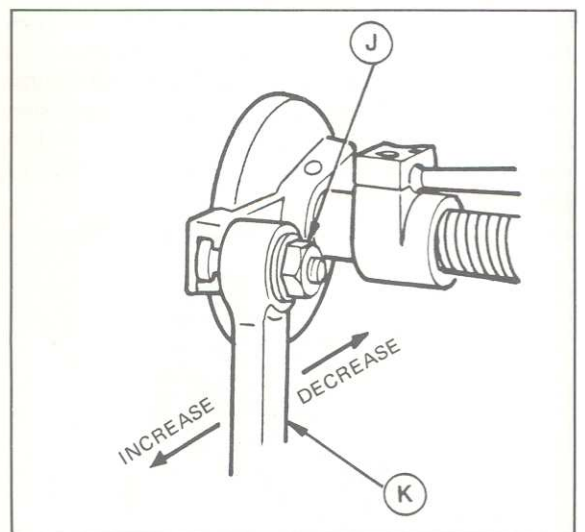

FEED UNIT & FEED SCREW

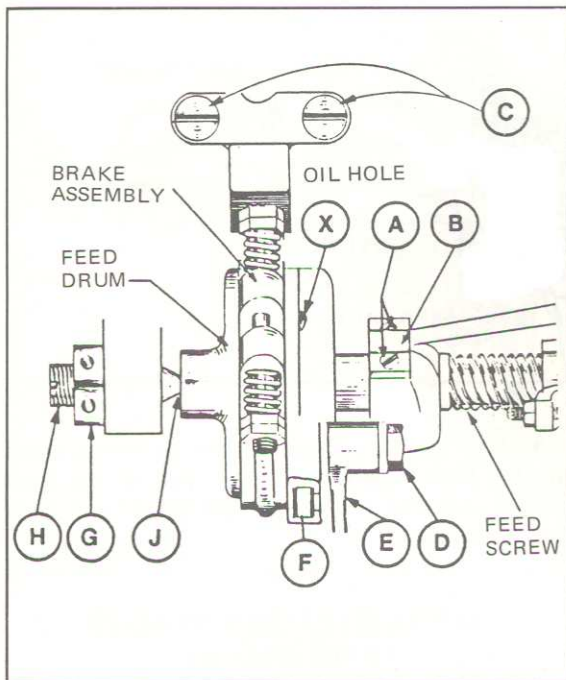

FEED MECHANISM

The feed unit should be lubricated twice daily with a few drops of oil inserted through oil hole (X). Use a medium viscosity oil with minimum gumming effect. Electric motor oil is recommended. Do not apply any oil to the brake or drum.

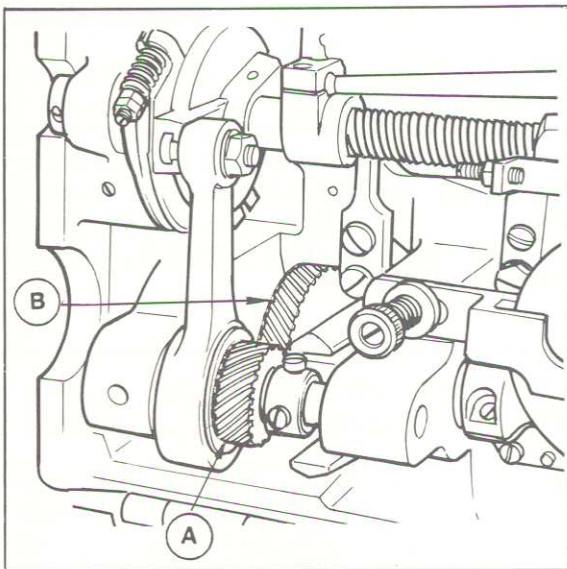

Adjust mesh timing of Feed Gear (A) with Feed Drive Gear (B) so that feeding of the first row of stitches will start when center of needle eye aligns with top surface of Throat Plate on its upward stroke.

TO DISASSEMBLE FEED SCREW MECHANISM

1. Remove the two Screws at (A) and lift off Cap (B). Remove two Screws (C), loosen Nut (D) and swing Arm (E) out beyond Slot (F). Loosen Lock Nut (G) and back off Bearing Screw (H) sufficiently to clear the end of Feed Screw at (J).

2. Remove the Feed Screw and attached members from the machine by swinging the entire assembly outward and to the left of the Bedplate.

Do not disassemble the Feed Unit without making provisions as described for retaining the internal parts which are assembled under pressure.

TO DISASSEMBLE FEED UNIT

1. Remove two Lock Nuts and Set Screws at (A).
2. Withdraw Shifter (B) from the Feed Case.

3. Insert a small diameter Drift Pin (preferably of Brass) through opening (C) in the Feed Cage, so that it contacts the inside of the Feed Drum. Then while holding the unit inside of a small box for retaining the parts, as shown, tap the end of the Drift Pin lightly to drive the Feed Drum off the Feed Screw Shaft. After the Drum has been removed, the internal parts will be fully exposed for inspection.

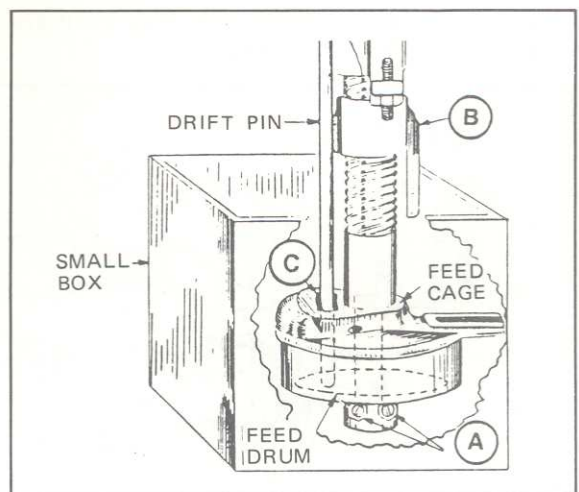

FEED MECHANISM

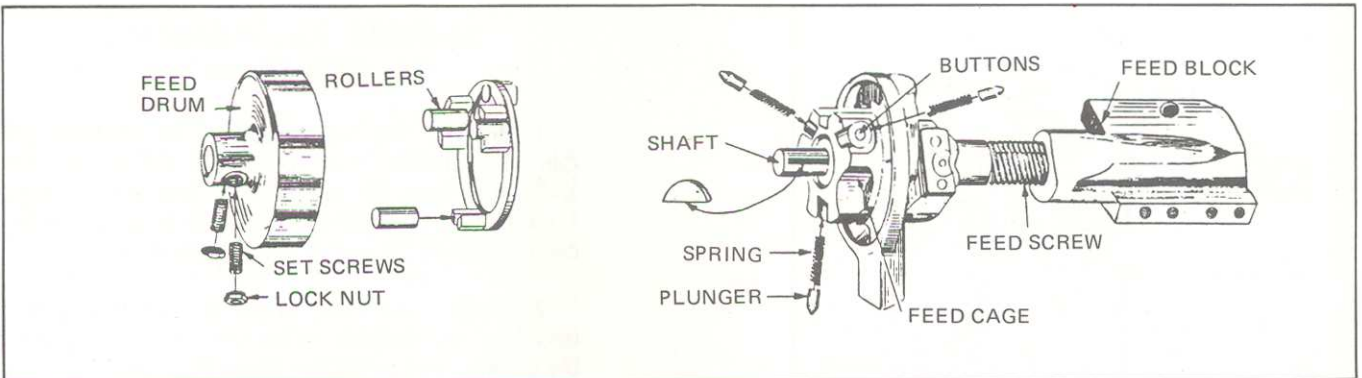

TO ASSEMBLE FEED UNIT

1. Make sure that all parts are thoroughly clean and in good working order.

NOTE: The buttons, illustrated above, will become brightly burnished along parallel lines of contact with Rollers, but as long as the surfaces of the buttons remain smooth, their positions in the Feed Cage should not be altered. If the buttons become worn due to lack of proper lubrication, they may be removed and rotated slightly to present new surfaces of contact for the Rollers. In this case, each button must be reinstalled in the the same recess of the Feed Cage from which it was removed and care must be taken to see that buttons are seated squarely to the full depth of the recess in the Feed Cage.

2. Assemble parts in the manner illustrated above.

NOTE: Special Retaining Ring 03-0049 is used, as shown, to hold the Rollers, Plungers and Springs in place while Feed Drum is pressed far enough on the Shaft to encircle the rollers. The Retaining Ring is then removed and the Drum is pressed the rest of the way to lightly contact the body of the Feed Cage. If Retaining Ring is not available, a heavy elastic may be used.

3. After the Feed Unit has been assembled, make sure the Feed Cage will oscillate freely on the Shaft without end play and tighten Set Screws and Lock Nuts securely.

TO ASSEMBLE FEED MECHANISM TO THE MACHINE

1. Reverse the procedure previously outlined for disassembly. After the Feed Mechanism has been installed, adjust cone point bearing screw (A) so that the Feed Screw (C) will turn freely without end play. Then tighten Locking Collar (B) securely.

IMPORTANT: Bearing Screw (D) has been set in the factory and need not be readjusted except when it is for any reason removed or replaced.

2. To readjust — swing Lever (F) out of Slot (M) and adjust Screws (A) and (D) equal amounts to the right or left so that the inside face of Washer (L) will show as much overlap as clearance at Contact (K) when Lever (F) is pressed from side to side. When this setting has been made, tighten Collar (E) on Bearing Screw (D), then proceed to set Bearing Screw (A) as outlined above.

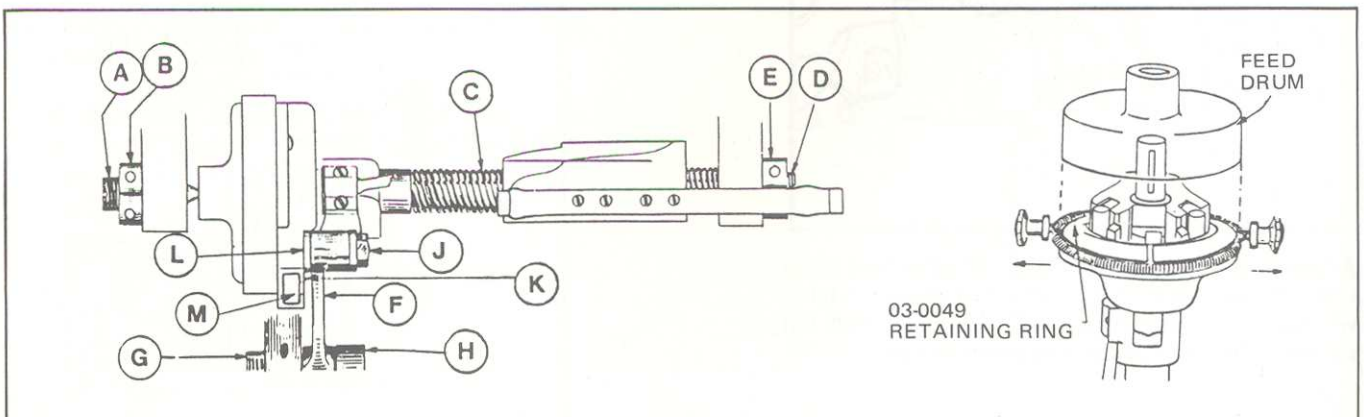

FEED SHIFTER TIMING

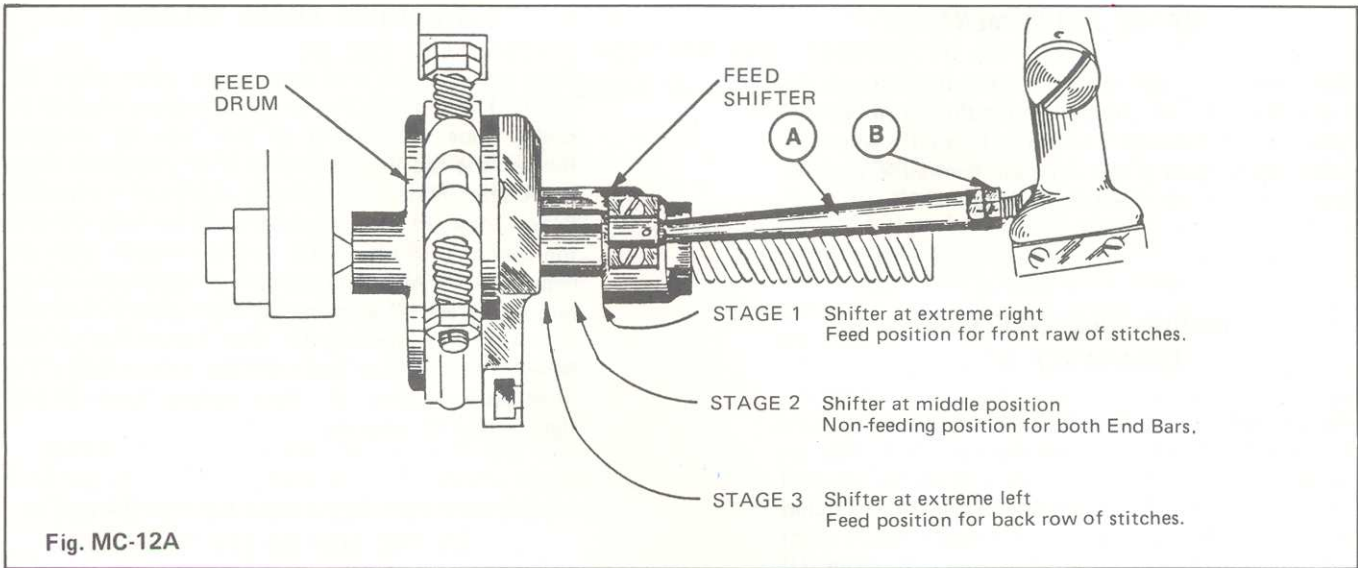

FEED SHIFTER

The Feed Shifter positions the Internal Ring and Rollers located in the Feed Unit, to feed in the required direction at the required time.

S3 TACKERS AND S3 LABEL SEWERS (MODELS S3-SRLS & S3-TRLS) ARE EQUIPPED WITH "2 STAGE" FEED SHIFTERS.

S3 LABEL SEWERS (MODEL S3-LS2N) ARE EQUIPPED WITH "3 STAGE" FEED SHIFTER AS USED ON S3 BUTTONHOLE MACHINES.

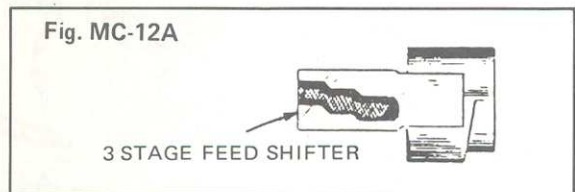
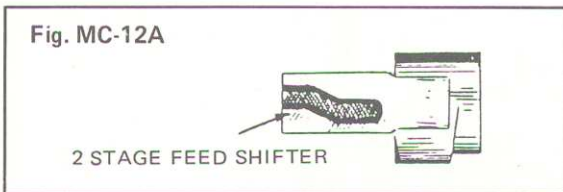

On all types of S3 Machines the Feed Shifter must be timed to shift from one Stage to another during the intervals when the Feed Drum, top of page, is absolutely stationary.

TO TIME FEED SHIFTER (all S3 Machines)

Stop machine at any point when the Clamp Plate is Feeding in the direction of the arrow shown at right. At this time the Feed Shifter should be 0.420" from the Feed Cage. Use 03-0050 Gauge in the manner illustrated for checking this measurement. If adjustment is necessary loosen Nut (B) and turn Rod (A) in either direction as required until the setting exists when Nut (B) has been tightened securely.

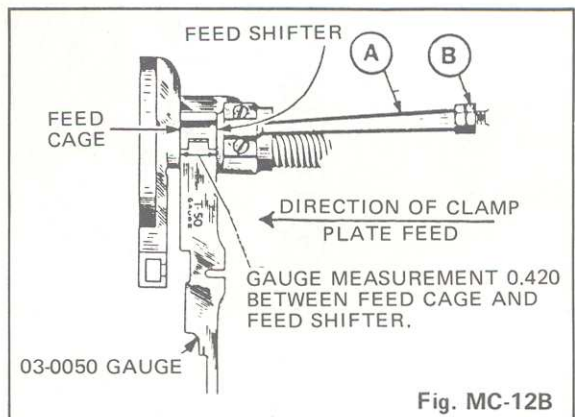

BRAKING

BRAKE ADJUSTMENT

This Brake operates with constant pressure of the Brake Shoe (H) on Drum (L) over the entire cycle of operation. The pressure of Shoe (P) is OFF when the Clamp Plate feeds in the direction marked X, and ON when the feed is in the direction marked Y.

TO ADJUST BRAKE RELEASE FOR CLEARANCE AT Z:

Adjust Nuts (G) so that Brake Shoe (H) exerts light pressure on Drum (L) and position Nuts (M) on Screw (N) as shown. Then remove Screws (S) and swing Arm (K) so that bump of Bushing (Q) matches groove in Arm (K) as shown in detail view. A slight amount of play should exist between Bushing (Q) and Arm (K), so that Brake Shoe (P) will be free to contact Drum (L). If no clearance exists, or if there is too much play, adjust as follows: Loosen Nut (F) and turn Screw (N) inward or outward until the described result is obtained. Then tighten Nut (F) and replace Screw (S).

TO ADJUST BRAKE RELEASE

Start the machine and stop at any point when the Clamp Plate is feeding in the direction marked X. Brake Shoe (P) should at this time be released. Restart the machine and stop it at any point when the Clamp Plate is feeding in direction marked Y. Brake Shoe (P) at this time should be fully ON and the bump on Bushing (Q) should coincide with the depression in Arm (K) as shown in detail view. If not, remove Screw (S) and line up depression in Arm (K) with bump on Bushing (Q), then loosen Nut (J) and Screw Rod (T) in or out until the loop in Rod (T) is lined up with Hole (R). Then replace Screw (S) and tighten Nut (J) securely.

TO VARY THE RELATIVE STITCH DENSITY OF ONE ROW TO THE OTHER

Set the Stitch Regulator, illustration on bottom of page 14, for the desired overall Stitch density. Then adjust the pressure of Brake Shoe (P) by means of Nuts (M) to increase or decrease the Stitch density of one row to the other. Reset the Stitch Regulator again if that seems necessary.

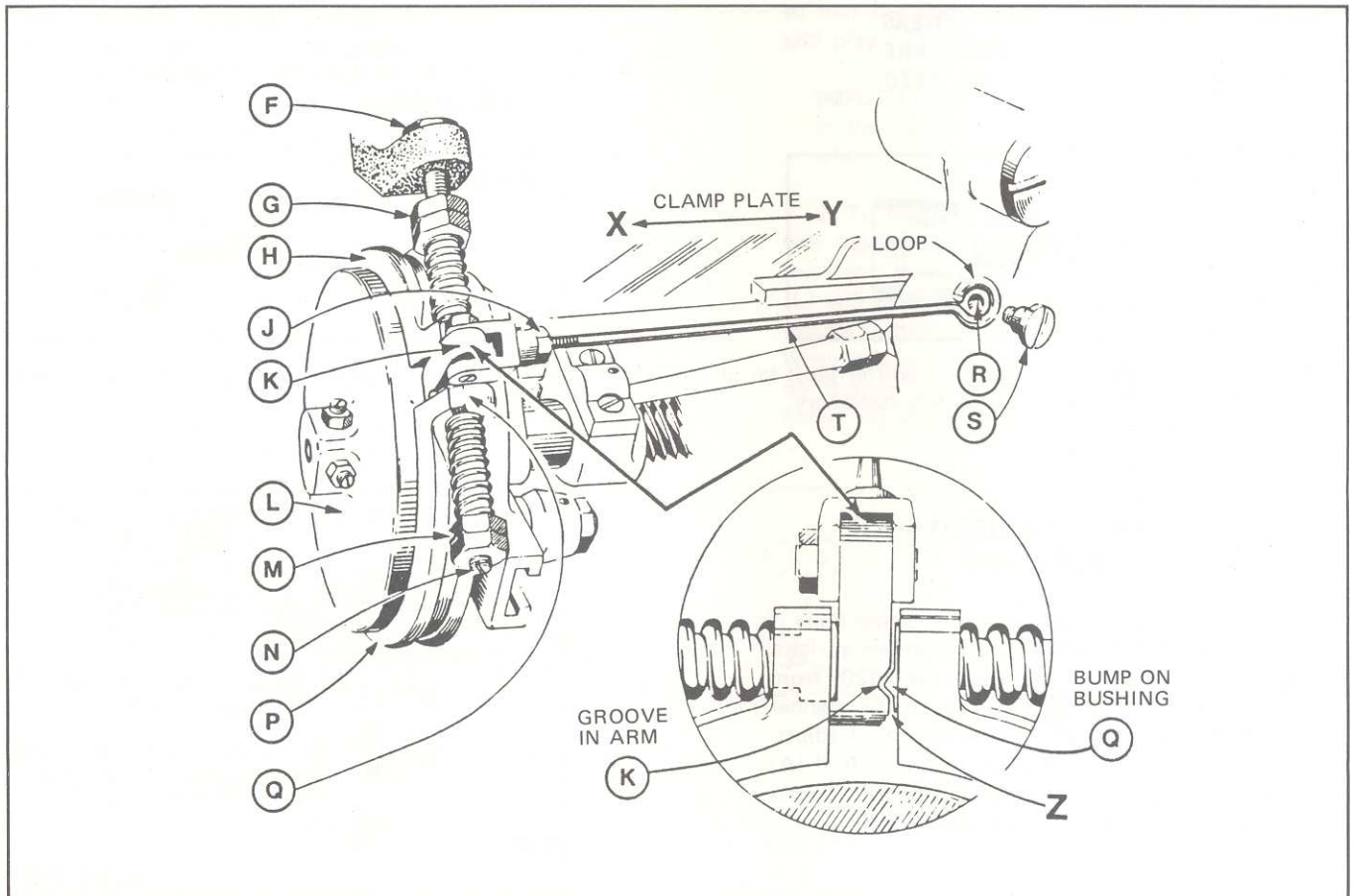

CUTTING

TO SET CLAMP PLATE POSITION WITH RESPECT TO CUTTING (For Buttonhole Machines only)

1. Operate Machine through its Cycle and Stop Machine just before the Cutting Action is about to occur.

2. Tip Machine back on its Hinges and turn Drive Pulley with Pin Wrench until Stop Bolt (H) shifts to the right. Then turn Drive Pulley slowly until Roll (B) is resting on the Cam Lobe marked X as shown at (A).

NOTE: The Cam Lobe marked X is the Low Lobe of the barring Cam which brings the Clamp Plate to the Central Point where the Cutting Action takes place.

3. With Roll (B) resting on the Low Lobe marked X of the Barring Cam as shown, loosen Nut (E) and Screws (D) and (F). Then press Stop Plate (C) firmly upward against the notch in Latch (G) in the position shown. While holding the Stop Plate (C) in this position, tighten Screws (D) and (F) and Nut (E) securely.

NOTE: Latch (G) should be seated on Stop Plate (C) as shown when the Machine comes to its normal stopping position at the end of each operating cycle.

Fig. MC-11

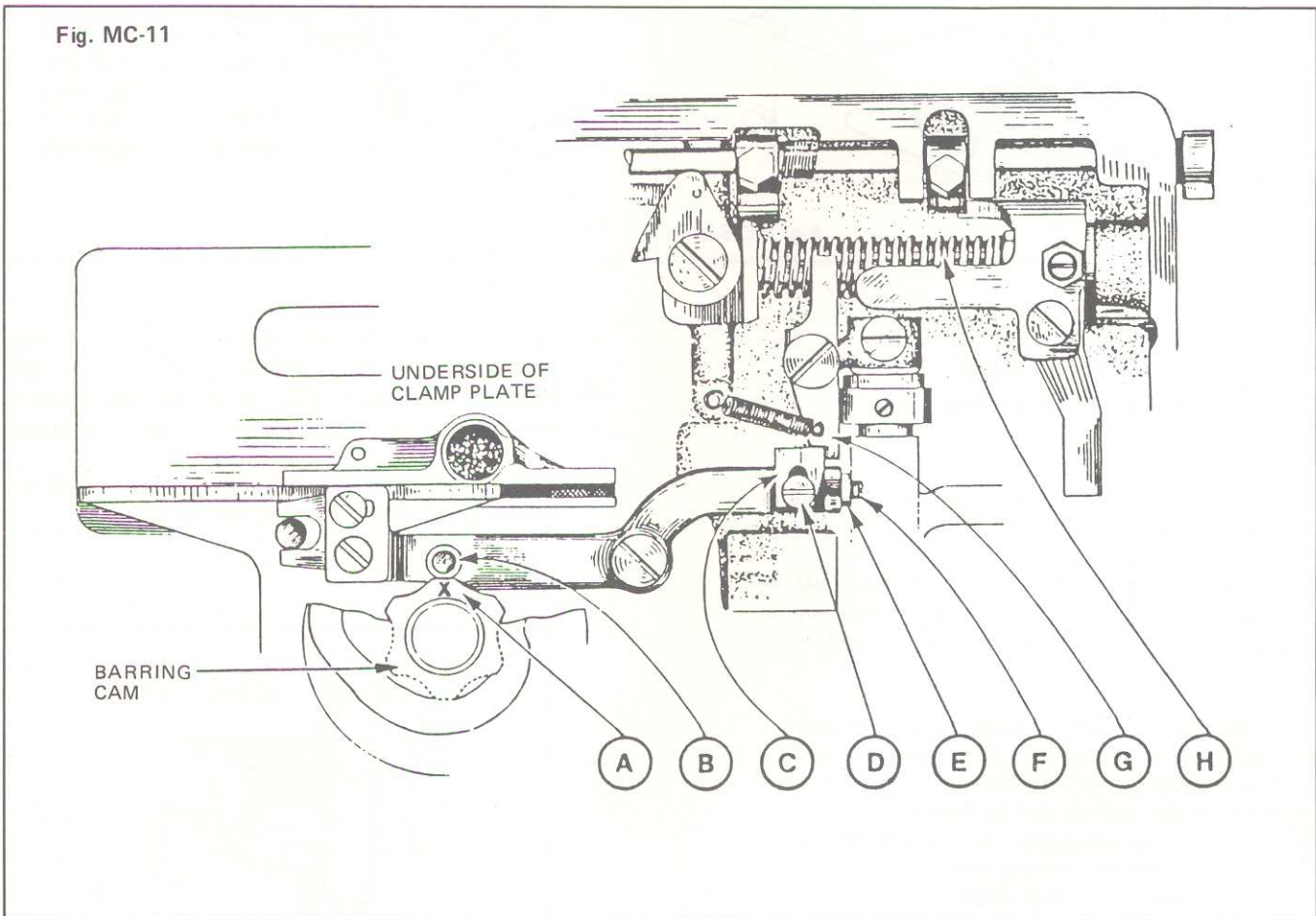

CUTTING

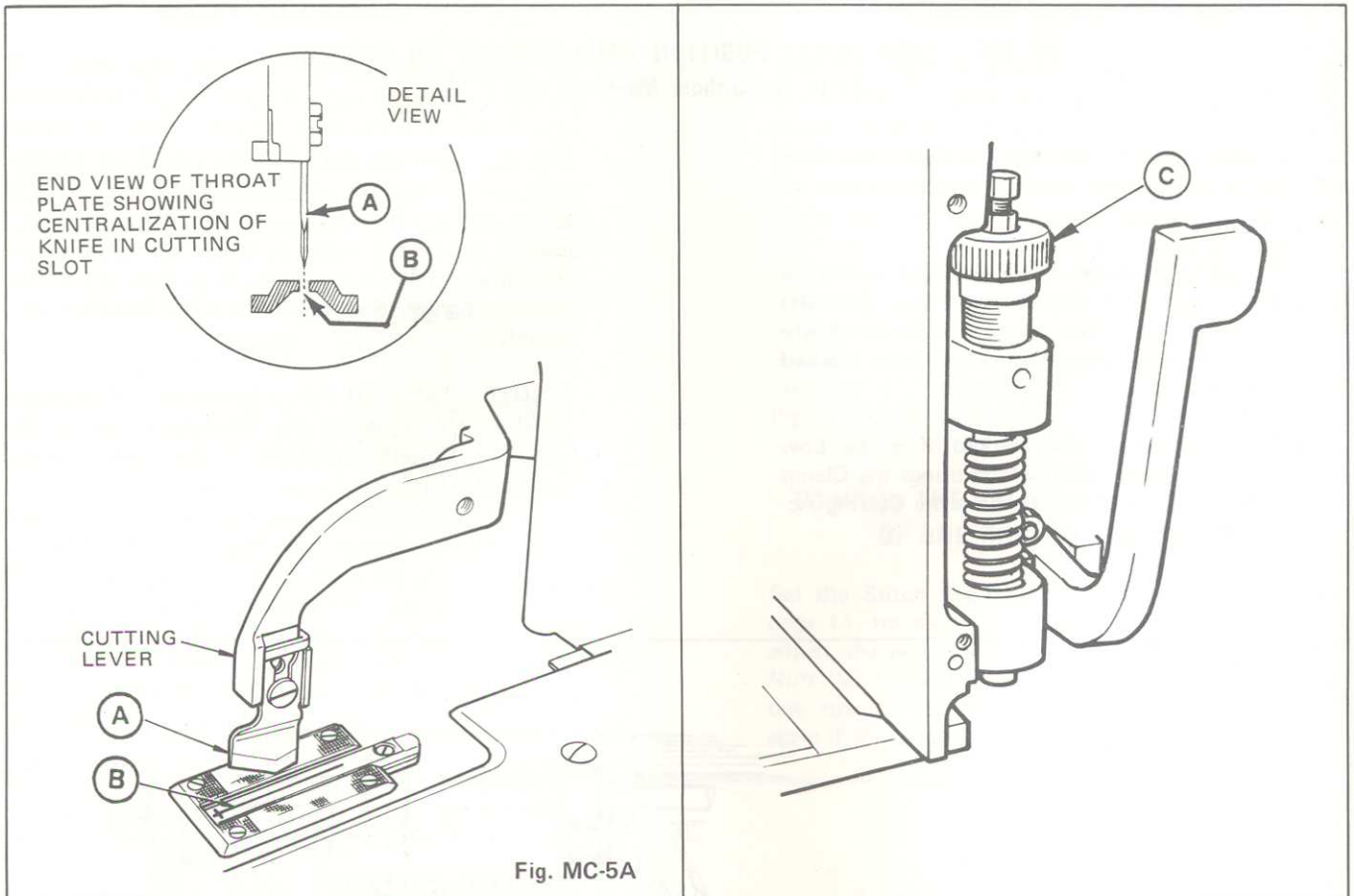

Fig. MC-5A

TO CENTRALIZE KNIFE IN CUTTING SLOT (For Buttonhole Machines only)

1. Test Knife (A) for straightness. If bent or damaged, install a new knife.

2. Note the position of Nut (C) so that it can be returned to the same position later. Then remove Nut (C) to release the spring pressure on the Cutting Lever.

3. Depress the Cutting Lever to test the position of Knife (A) in cutting slot (B). With no side play in the Cutting Lever, the Knife should be exactly centered in the cutting slot as shown in detail view. If adjustment is necessary, tip the machine back, loosen Screw (D) and remove Screw (F). Then press Stud (H) upward so that Collar (G) bears firmly against Boss (E). While maintaining this contact, screw Collar (G) up or down on the hub until the knife is centered in the cutting slot as described above. Reinstall Screw (F) in the most accessible

hole in Collar (G) and tighten it securely. Then press upward on Stud (H) and tighten Screw (D) securely. Recheck to see that no side play exists in the Cutting Lever and that Knife is properly centered.

4. Replace Nut (C) and adjust it to restore the normal spring pressure on the Cutting Lever.

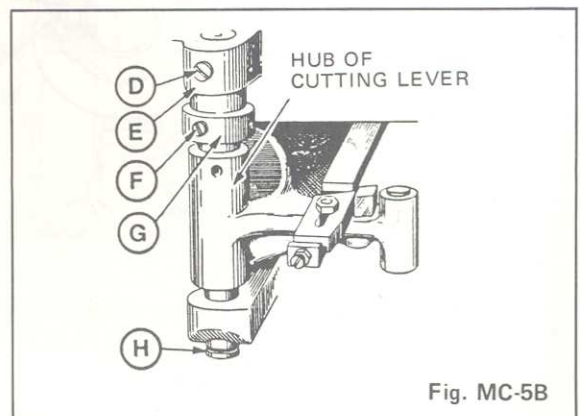

Fig. MC-5B

CUTTING

PLUNGER ADJUSTMENT

The cutting momentum of the machine is controlled by Adjusting Screw (F).

TO ADJUST FOR AVERAGE CUTTING CONDITIONS:

With the machine in its normal stop position and *clamps down*, loosen Nut (H) and Screw (G). Turn Knurled Adjusting Screw (F) as required until top of Plunger (C) is approximately 1/16" above the top of Adjusting Screw (F). Make sure that flat surface of (F) is facing (G), then tighten Screw (G) and Nut (H).

Loosen Lock Nut (B) and adjust Screw (A) so there is a wink of clearance between Plunger (D) and Anvil (E).

NOTE: If cutting momentum is excessive and machine stops too abruptly, turn Screw (F) downward until the blow is softened. If the momentum is insufficient to carry the Drive Pulley to stop position, first check that the belt is reasonably tight and then, if necessary, turn Screw (F) upward until a point is reached where the Drive Pulley carries fully over to stop position.

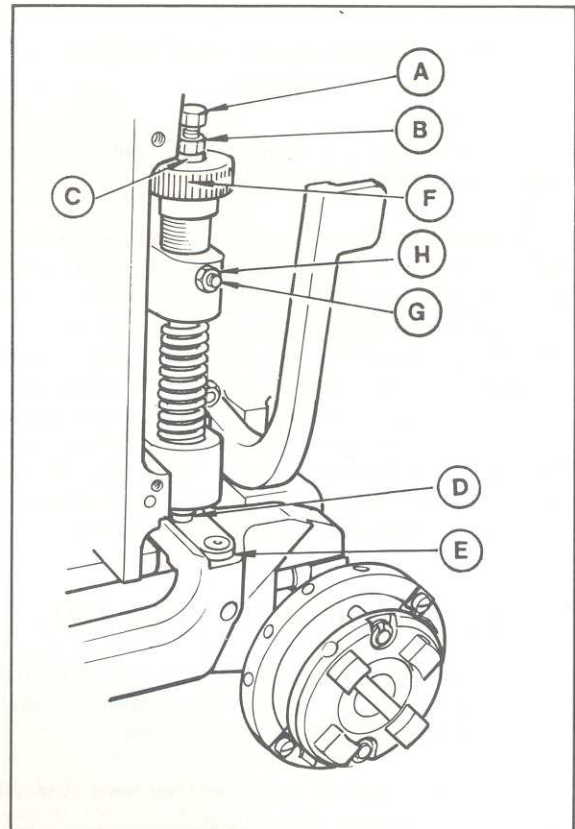

Belt		Pulley	
Part No.	Description	Part No.	Description
05-1318-0-000	M type 35" (V belt)	23-2095-0-050	3" dia. (12mm ball bearing)

CLAMPING

TO SET POSITION OF UNCLAMPING HANDLE

1. Depress Starting Pedal so that Clamp Feet descend on bare Clamping Mat.

2. When the Clamp Feet are on the bare Clamping Mat, as shown at right, approximately $1/64''$ clearance should exist between Clamp Tailpiece (A) and Unclamping Handle (D) through the entire length of the Clamp Travel. To test this, start and stop the machine at short intervals and move Unclamping Handle (D) back and forth to see that the clearance exists at all points. If adjustment is necessary, open back cover on head of machine, loosen Nut (B) and adjust Screw (C) until the above specified play is obtained. Then tighten Lock Nut (B) securely.

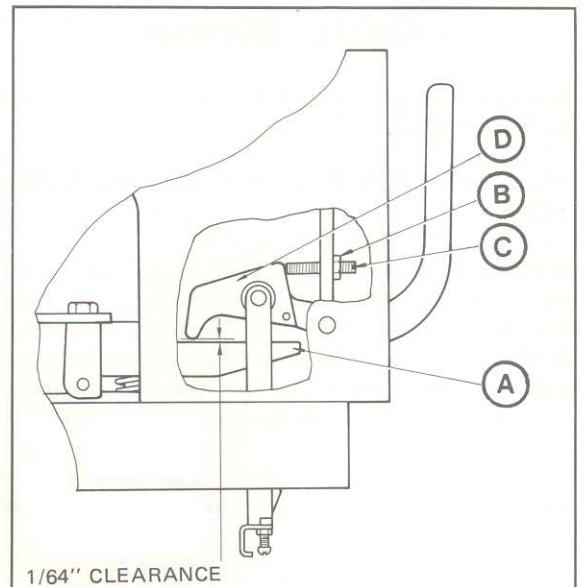

TO ADJUST HEIGHT OF CLAMP ARM

1. Loosen Nuts (H) and (M) and turn Adjusting Screw (N) inward to increase the Clamp Elevation and outward to decrease Clamp Elevation.

2. After the desired adjustment has been obtained tighten Nuts (H) and (M) securely.

TO ADJUST CLAMP TRIPPING

1. With machine in normal stopping position, loosen Screws (Q) and adjust Bracket (R) so that minimum clearance exists between the Starting Lever and Bedplate (distant X-Y).

2. Depress the Starting Pedal slowly to test the clamp tripping action. The Clamps should descend before the Stop Bolt Holder (G) starts to move to the left. If not, adjust as follows: Tip machine back on its hinges, loosen Screw (L) and set Lever (I) to trip the clamps as described above. Then tighten Screw (L) securely. Raise clamps by pressing Lever (E) to the left. Recheck Clamp descent by pedal action. If necessary repeat the adjustment until the Clamps descend as described above.

NOTE: When this adjustment is correct, a gap of approximately $1/32''$ to $1/16''$ will exist at (F) each time the machine stops under power.

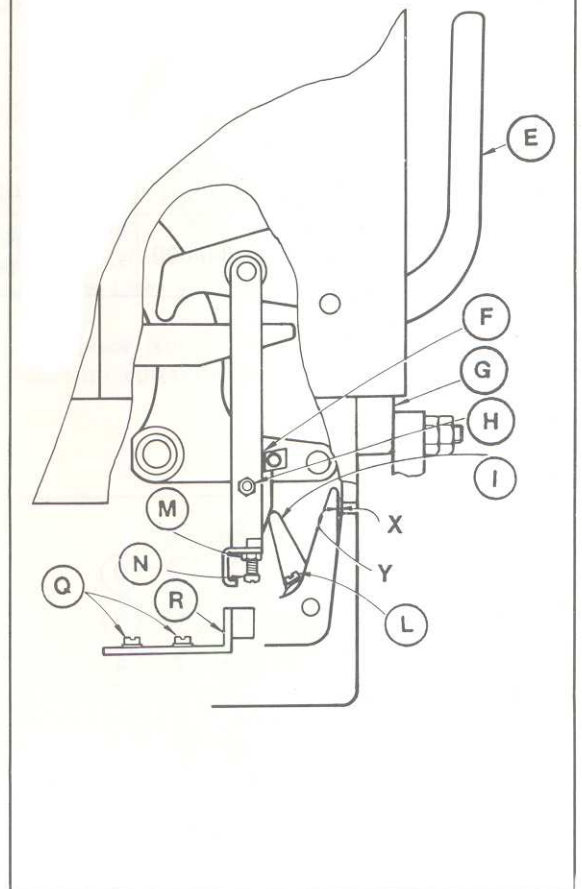

STOP MOTION

TO ADJUST FOR CLEARANCE BETWEEN STOP BOLT AND DRIVE PULLEY

With Motor OFF, depress starting pedal to place machine in sewing position. In this position a clearance of .003"-.004" should exist between Stop Bolt (A) and Cam (B) as shown. If adjustment is necessary, loosen Nut and Screw (K), then Locknut (H) and turn Nut (J) inward or outward until the desired adjustment has been obtained. Then hold Nut (J) stationary and tighten Lock Nut (H) and tighten Screw and Nut (K) securely.

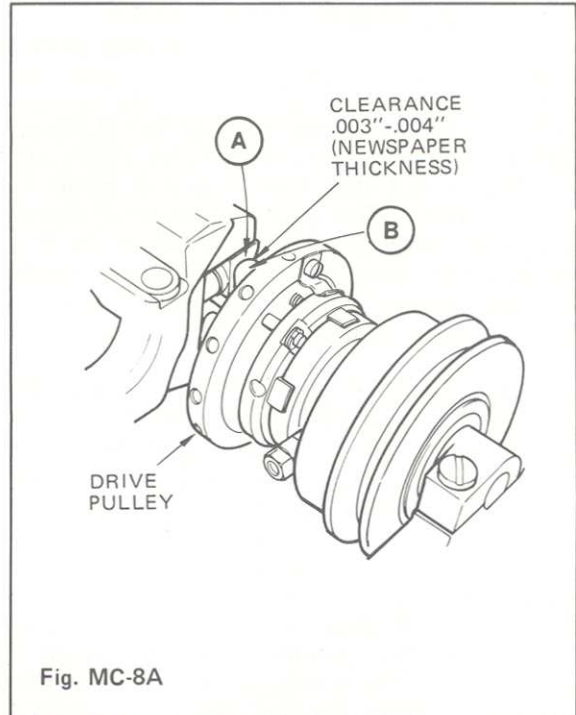

TO ADJUST TRIP LEVER

Operate machine to a point just before the normal stopping position. Then turn Drive Pulley until Trip Lever (E) has approached very close to Knock-

off Post (D) on Latch (C). At this time, the end of Trip Lever (E) should overlap Post (D) approximately 1/8" as shown in enlarged view. To adjust, loosen Lock Nut (G) and adjust Screw (F) inward or outward, as required, until the above specified overlap has been obtained. Then tighten Lock Nut (G) securely.

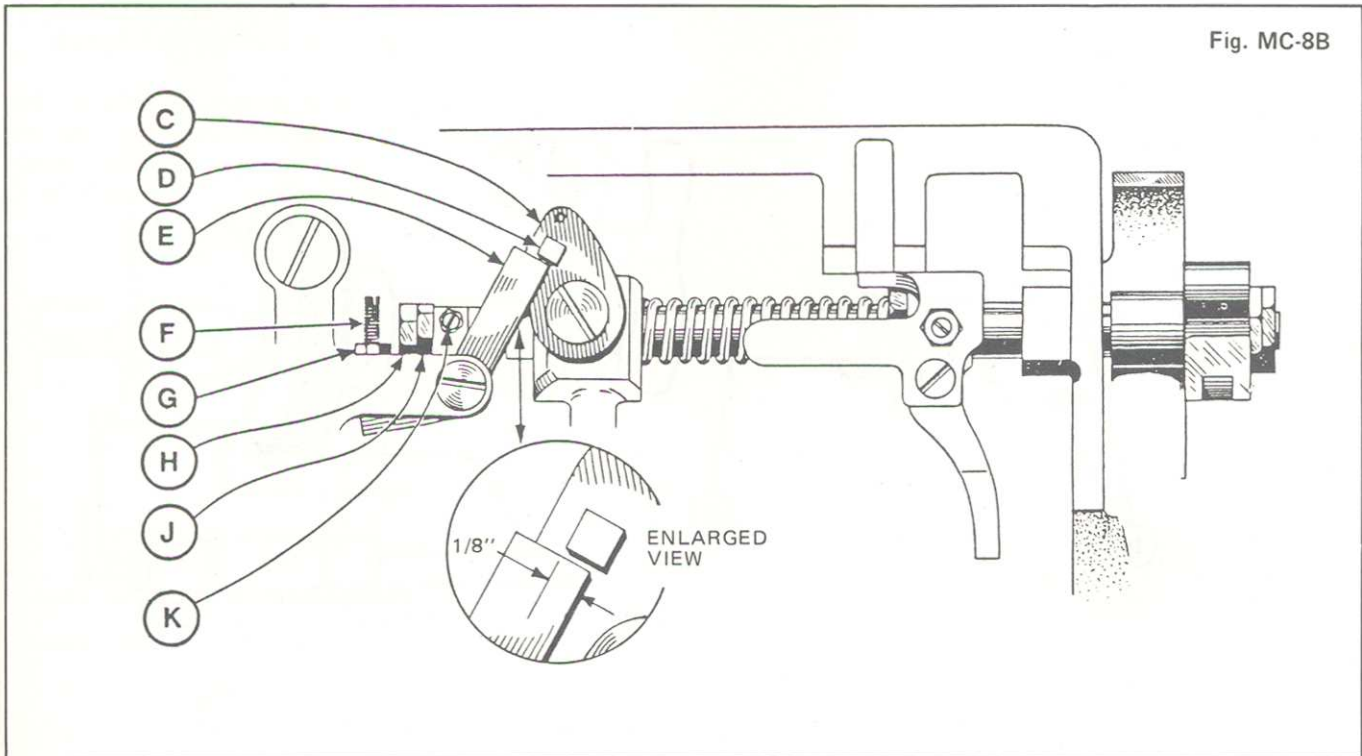

STOP MOTION

TO TIME STOP BOLT SIDE SHIFTING ACTION

With the machine in position described in the preceding adjustment, turn Drive Pulley slowly with Pin Wrench and stop when Stop Bolt Holder (L) shifts outward. This action should occur immediately after Large Lobe (N) of the Cam on the Drive Pulley passes point (M) of the Stop Bolt Holder. The gap between the Cam and the Holder at this point should be no more than $1/32''$ as shown.

On S3 Buttonhole machines, S3 Wide Bite Tackers and Collar Stay Tackers, the Stop Bolt Holder will automatically shift in the above described manner when the Barring Cam adjustment has been established as described on page 12.

On S3 Tacking and S3 Label Sewing machines which have no barring movement of the Clamp Plate and on S3 Cut-After Edgers (S3-CAED), the adjustment should be made as follows: Loosen two Screws (P) and turn Gear (R) in either direction until a setting is obtained where the Stop Bolt Holder shifts to the right in the manner described above. Then press Gear (R) against Collar (S) and tighten Screws (P) securely.

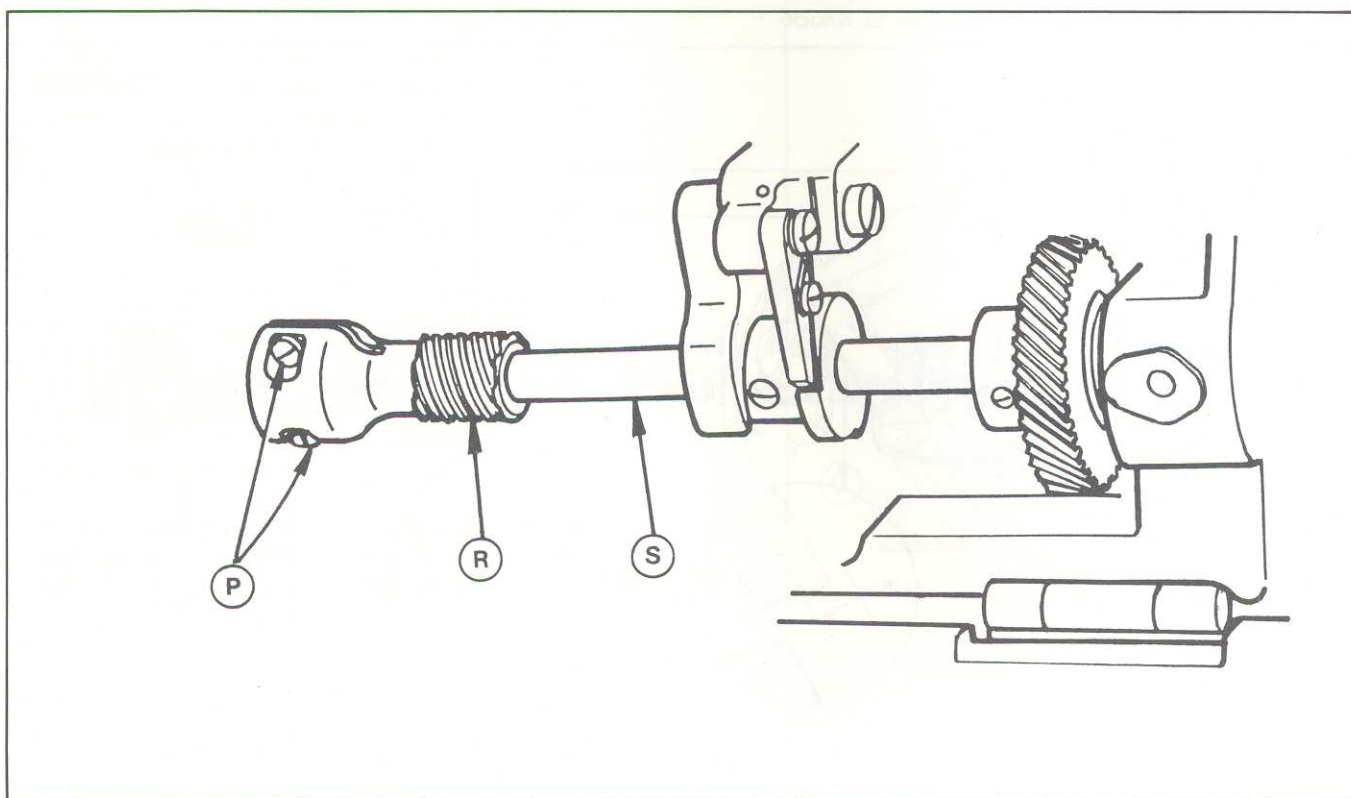
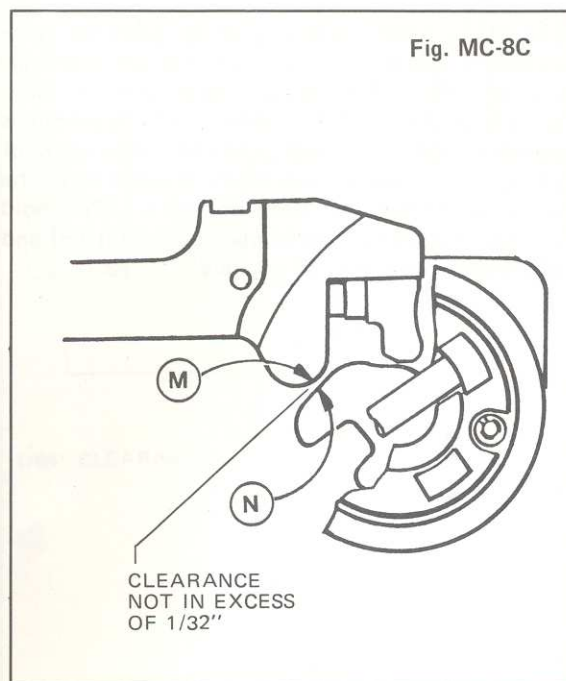

CLUTCH

ADJUSTMENT OF CLUTCH DRIVING ARM

With machine in operating condition, Clutch Driving Arm (G) should lightly contact lower Roller (I) on Clutch Shifter Lever (H). Adjust by loosening Screw (J) and adjusting position of Clutch Driving Arm (G). If the clearance is too big, there will be an excessive shock when the clutch is disconnected and being in a half-clutch condition, care must be taken as it will be case for heating of the clutch.

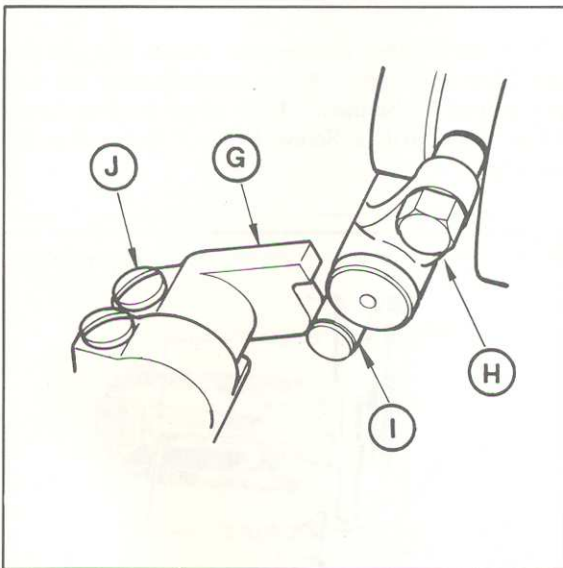

ADJUSTMENT OF CLUTCH START ARM AFTER EMERGENCY STOP OF MACHINE

With machine in operating condition, loosen Clutch Start Arm Screw (K) and adjust so that when pedal is pressed fully down, there is a slight clearance between Clutch Start Arm (L) and Clutch Start Pin (M).

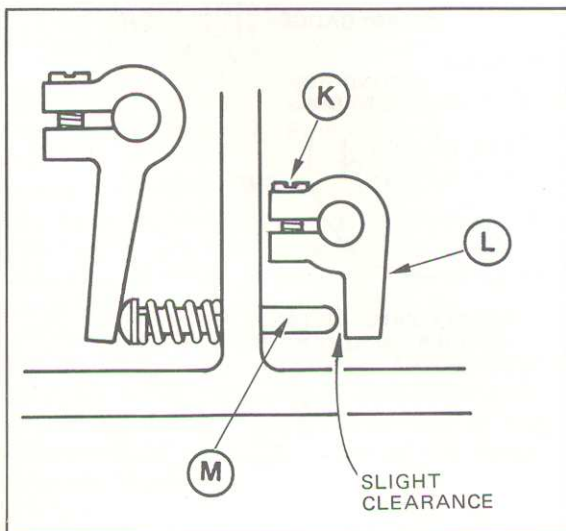

DRIVE PULLEY ADJUSTMENT

When machine is in normal stopping position a clearance of 1/64" should exist between Leather Brake Shoe (H) and side of Pulley (G) as shown. To adjust, tip machine back on its hinges, loosen Screw (J) and position Brake (K) in or out as required. Then tighten Screw (J) securely.

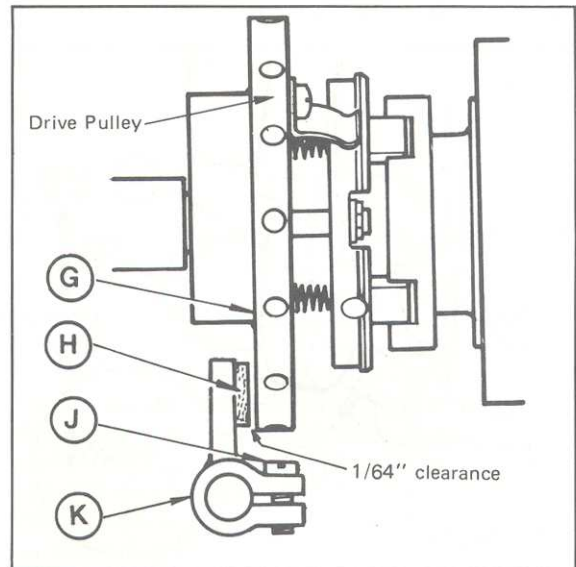

STITCH BITE

STITCH BITE SETTING

A $3/32''$ Stitch Bite Setting is standard for most types of material (see Detail 1). As illustrated, Stud (A) for the $3/32''$ Bite should be approximately in the center of Slot (C). To adjust for more or less Bite, loosen Nut (B) and move link (D) in the direction required as indicated by arrows and tighten Nut (B) securely.

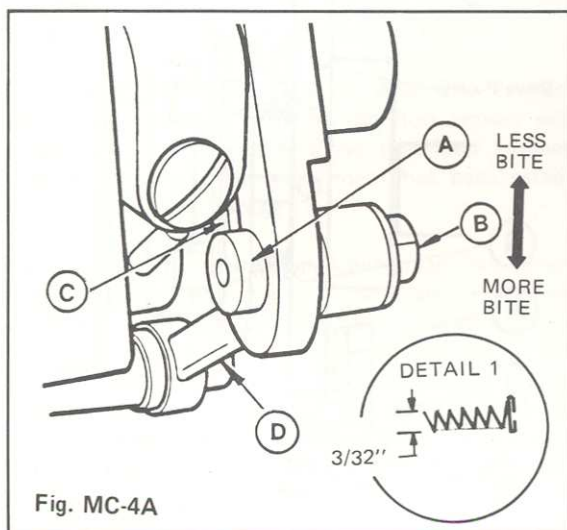

Fig. MC-4A

FOR S3 BUTTONHOLE MACHINES USING REGULAR, MEDIUM OR NARROW BITE THROAT PLATES: —

Bites are R— $3/32$, M— $5/64$, N— $1/16$ inch. Adjust the Needle Thrust in relation to cutting slot in throat plate as follows:— (see page 30 for wide and extra wide bite throat plates).

1. Make sure that Needle is straight.
2. Turn Drive Pulley until the Needle descends on its front stroke as illustrated.
3. Insert 03-0050 Gauge as shown with its flange fitting in the cutting slot of the Throat Plate.
4. Loosen Nut (E) and turn Eccentric Screw (F) until the Needle is directly in line with the Stitching line on the 03-0050 Gauge. Then, while holding Screw (F) in place with a Screw Driver, tighten Nut (E) securely.

NOTE: This setting establishes the relation of the second row of stitches to the Cut, see Detail 2. To adjust for more or less than standard cutting space for sheer or extra heavy material, see page 30.

Adjusting cutting spaces to the first row of stitches, see page 30.

FOR S3 TACKERS, LABEL SEWERS AND CUT AFTER EDGERS —

Centralize Needle Thrust in Needle Hole of Throat Plate as follows:

1. Make sure Needle is straight.
2. Turn Pulley by hand and observe Needle Thrust into the needle hole of the Throat Plate on alternate downward strokes.
3. If adjustment is necessary, loosen Nut (E) and turn Eccentric Screw (F) as required until the correct setting is obtained. Then while holding Screw (F) in place with a Screw Driver, tighten Nut (E) securely.

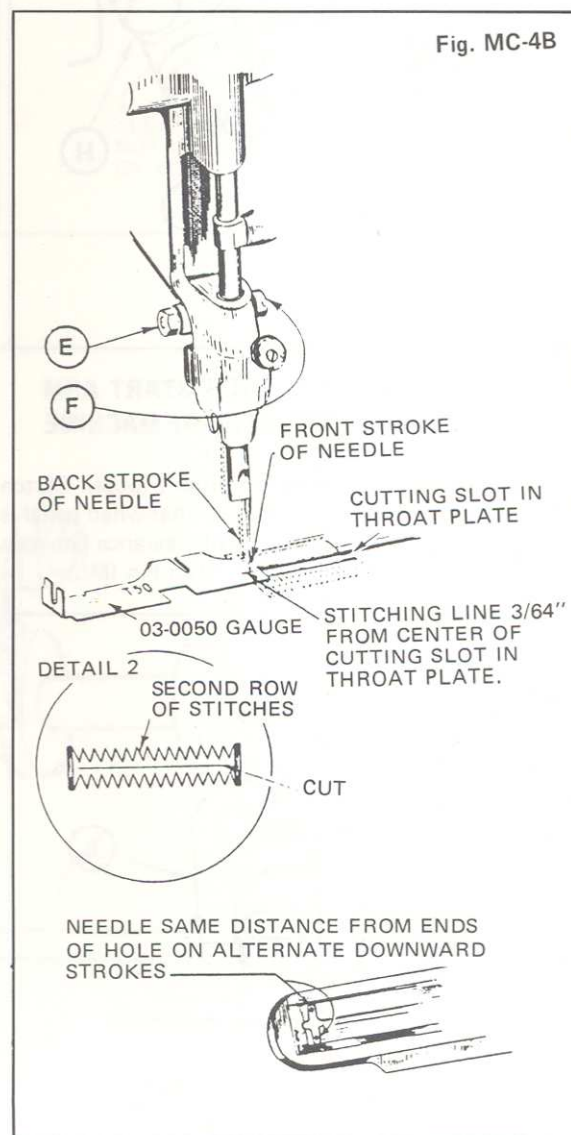
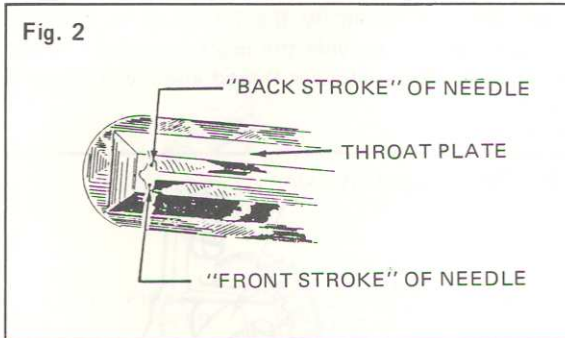
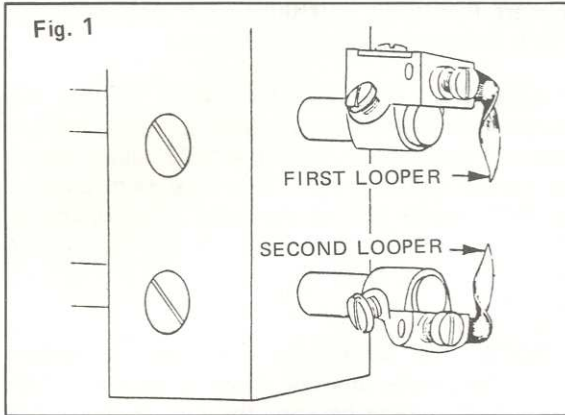

Fig. MC-4B

RELATED LOOPER & NEEDLE BAR SETTINGS

NOTE: In the following adjustments "First" and "Second" Loopers will be referred to as shown in Fig. 1. "Front" and "Back" strokes of Needle will be referred to as shown in Fig. 2.



1. Check to see that Needle is straight and inserted as high as it will go in the Needle Bar.

2. Make sure that needle thrust in respect to cutting slot in Throat Plate is established as described on page 26.

3. Adjust Needle Bar "Rock-over" Position as follows:

Make sure machine is in Normal Stopping Position, that is, with Stop Bolt (E) in the recess of Cam (D).

Using 03-0045 Pin Wrench, as shown, rotate Drive Pulley as far back as it will go in direction of arrow marked (X) and then as far forward as it will go in direction of arrow marked (Y). The spring on the Stop Bolt will be compressed during this movement. As the Pulley is rotated from the back position (X) to the forward position (Y), the Needle Bar should first rise a slight distance and descend twice the distance that it has risen. A Scale may be used, as illustrated, at right, for measuring the Needle Bar rise and descent.

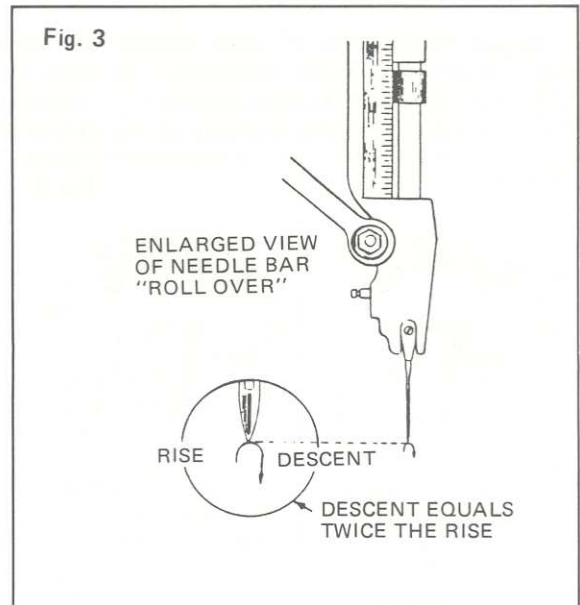

If adjustment is necessary, loosen the two Screws (B) on hub of Gear (C) and while holding the Drive Pulley stationary, adjust the Gear position as specified in Notes 1 and 2, until the required Needle Bar rise and descent has been obtained. Then tighten the two Screws slightly and tap the Gear sidewise as required until a very slight amount of end play exists in the Main Shaft. Then tighten two Screws (B) securely.

4. Check to see that needle bar height adjustment is established as described on Page 10.

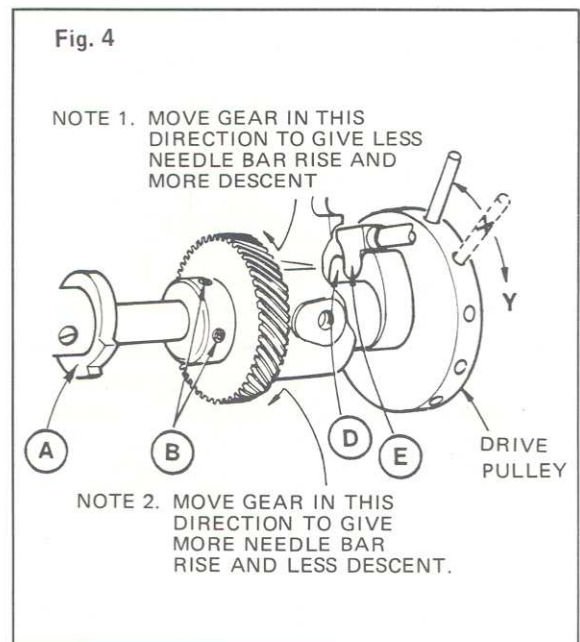

RELATED LOOPER & NEEDLE BAR SETTINGS

5. Set the Loopers to point inward at a very slight angle toward the Needle and position the Looper Holders so that side clearance exist between the Loopers and Needle as shown at Fig. 5 and 6.

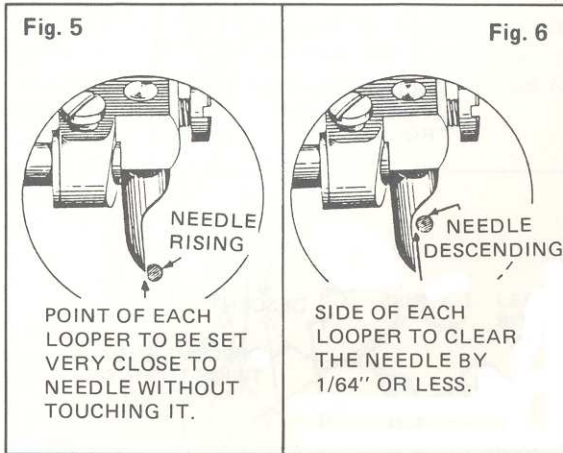

6. Using a Scale for measurement as shown, turn Drive Pulley until the Needle Bar has risen exactly 1/8" from the bottom of its front stroke. In this position, set the second Looper (Fig. 8) so that its point is at the center of the Needle Blade as shown. Again, using the Scale for measurement turn the Drive Pulley until the Needle Bar has risen exactly 1/8" from the bottom of its back stroke. In this position set the first Looper (Fig. 9) at the center of the Needle Blade as shown. After making these adjustments, reset the side clearance between the Loopers and Needle as shown in Fig. 5 & 6.

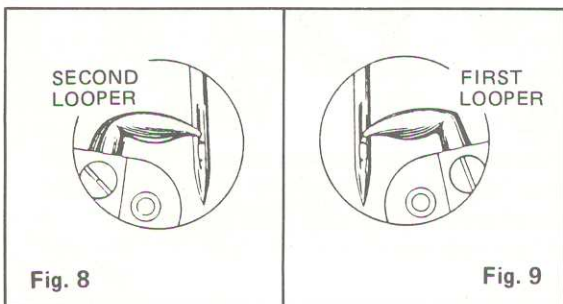
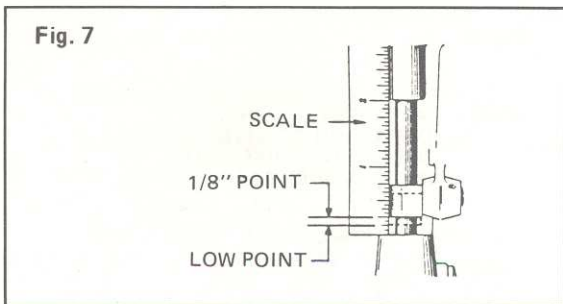

7. Turn Drive Pulley until the Needle is at the bottom of its front stroke. Check distance between point of Loopers using 03-0050 Gauge as illustrated (Fig. 10). This distance should not be less than 1/4" or more than 9/32". If the Looper points are not within these limits, proceed as follows:

If Loopers are less than 1/4" apart, advance the Looper Cam slightly according to following instructions. If Loopers are more than 9/32" apart, retard the Looper Cam slightly. Then reset both Loopers for 1/8" needle rise as described in paragraph 6.

NOTE: 1/8" Looper timing to needle is standard for most types of work, however once the 1/4" to 9/32" setting between the Looper points has been established, the Looper Cam may be advanced or retarded by the following micrometer adjustment, to provide the more favorable Looper action for the particular thread and material used.

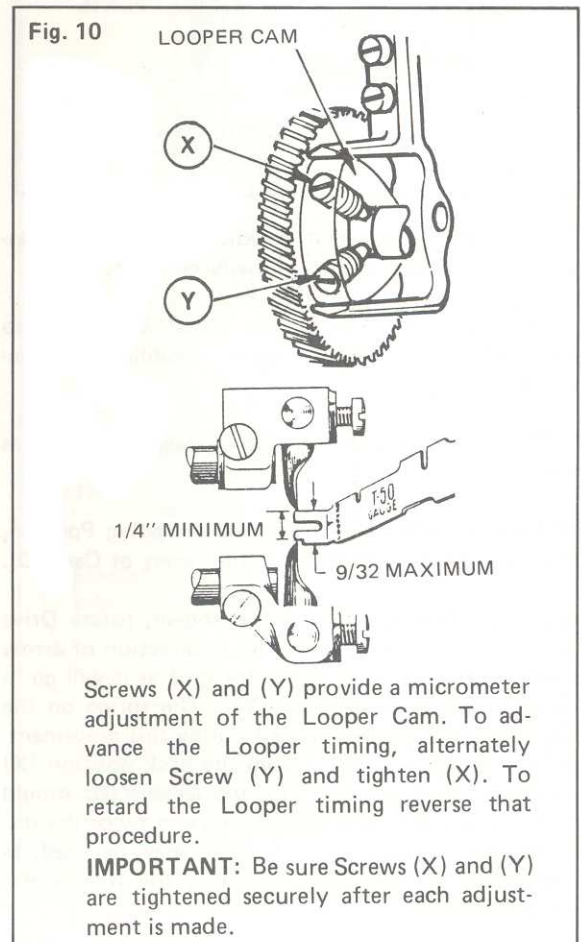

RELATED LOOPER & NEEDLE BAR SETTINGS

8. Thread the needle, place cloth under the clamps, tip machine back on its hinges, and turn drive pulley forward while observing the sewing action. Figures 11 thru 16, when viewed in succession, illustrate the manner in which first one looper and then the other looper should engage and disengage the thread in continuous sequence. Since the Loopers function similarly, the following instructions apply to both the first and second Loopers in the respectively opposite positions illustrated in figures (11 and 14), (12 and 15), (13 and 16).

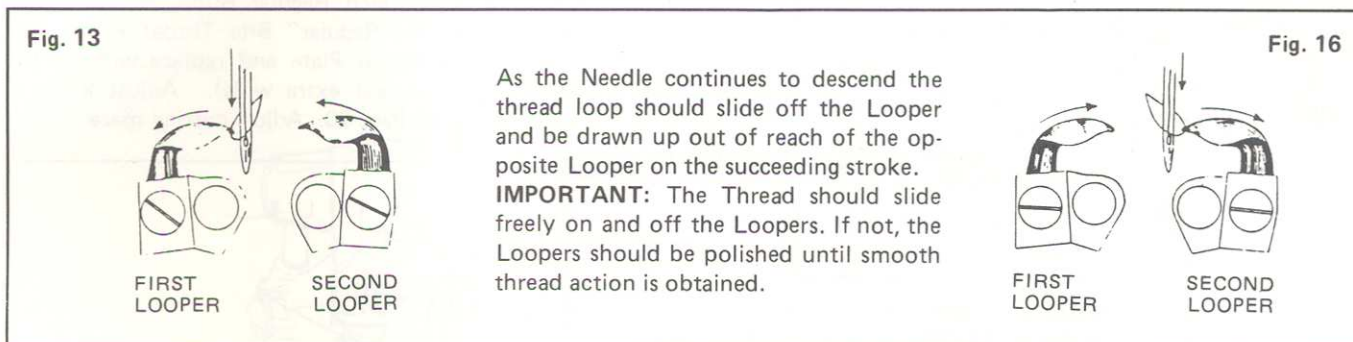
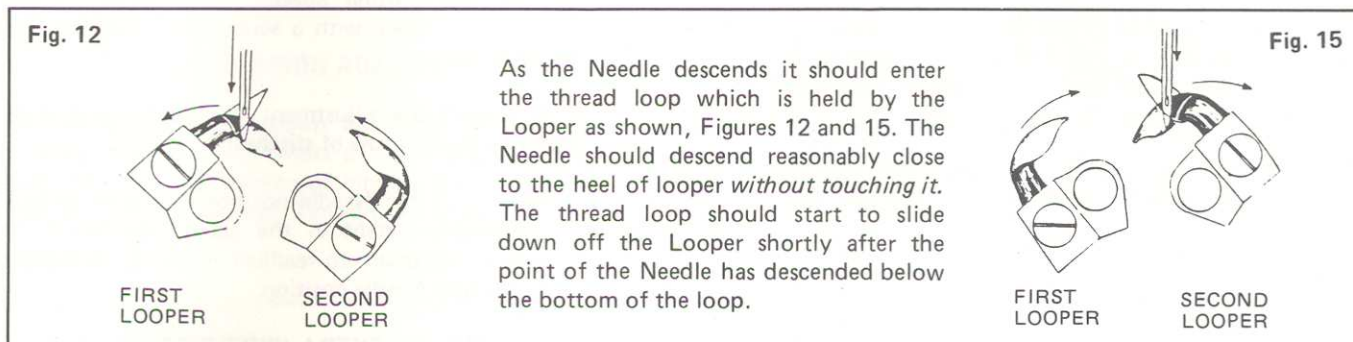
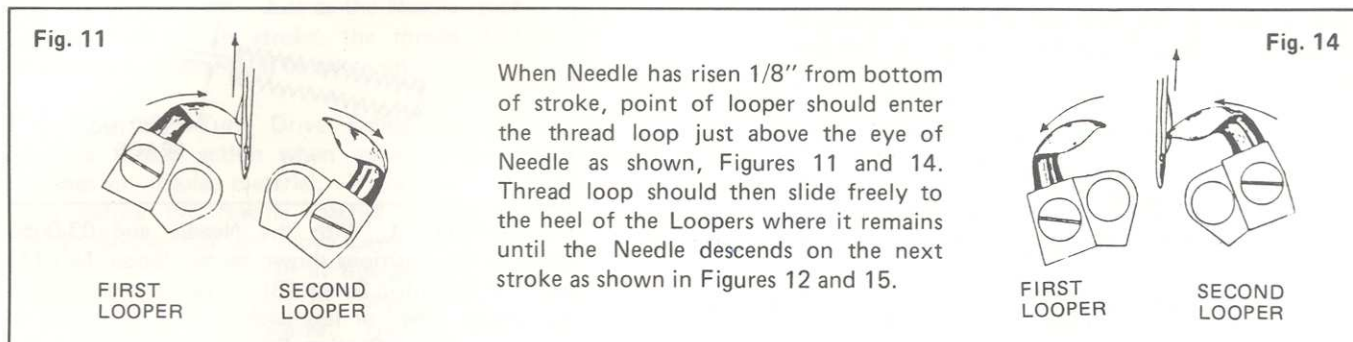

NOTE 1: The illustrations shown on this page apply to standard sewing conditions with a 3/32" stitch bite and normal cutting space between rows of stitches. In the event that the stitch bite or cutting space are abnormally wide or narrow, one Loper will pass higher above the eye of the Needle than the other. Also the Needle will pass closer to the heel of one looper than the other.

NOTE 2: Any changes in stitch bite or centralization of the needle vibration which appreciably alter the needle position will necessitate corresponding readjustment of the Loopers.

CUTTING SPACE

ADJUSTING CUTTING SPACE TO FIRST ROW OF STITCHES (For Buttonhole Machines only)

The Needle Setting to the 03-0050 Gauge shown on Page 26 established the standard cutting space to the second row of stitches. A similar amount of cutting space to the first row of stitches should be established so that the cut will be central between both rows.

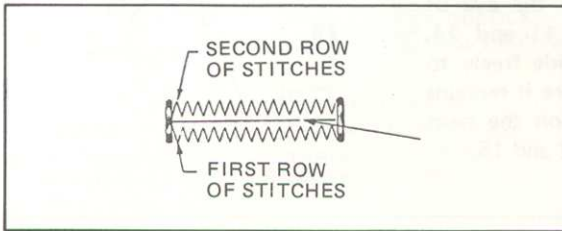

TO ADJUST: Loosen Screw (A). Turn Screw (B) inward or outward as required in accordance with the instructions, until the desired setting has been obtained. Then, tighten Screw (A) securely.

NOTE: To increase or decrease the overall cutting space between both rows of stitches, see below.

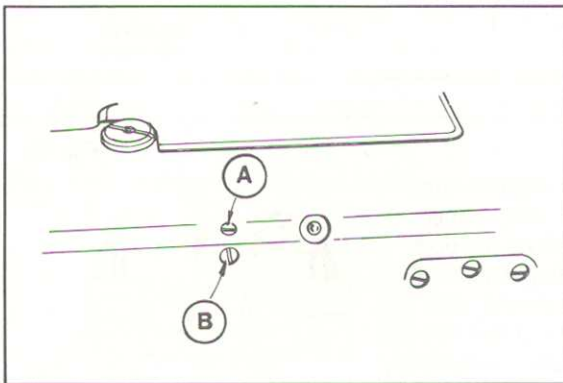

Screw inward for less distance between first row of stitches and the cut — or outward for more distance.

TO ADJUST FOR MORE OR LESS THAN STANDARD CUTTING SPACE FOR SHEER OR EXTRA HEAVY MATERIALS (For Buttonhole Machines only)

The Standard Cutting Space has been established by the two previous adjustments.

1. Setting Needle position to the 03-0050 Gauge as shown Page 26 which established the relation of the second row of stitches to the cut.

2. Setting the distance between the first row of stitches and the cut in the manner described and illustrated at left. Any change in the cutting space (more or less) will therefore require resetting both adjustments as follows.

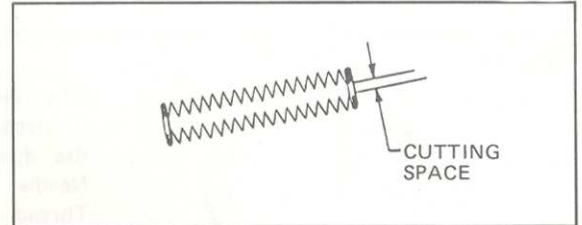

TO ADJUST: 1. With the Needle and 03-0050 Gauge in the positions shown below, loosen Nut (A) and turn Eccentric Screw (B) as required to position the Needle $1/64$ " or less back of Stitching Line on Gauge for more Cutting Space or in front of the line for less Cutting Space. Then while holding Screw (B) in place with a screw driver, tighten Nut (A) securely.

2. Repeat the adjustment, for adjusting Cutting Space to the first row of stitches.

NOTE: If the Needle position is altered to any appreciable extent in the above adjustment, it may be necessary to readjust the Loopers slightly to the new Needle position.

WIDE BITE and EXTRA WIDE BITE Throat Plates utilize a $3/32$ " inch Regular Bite. Adjust needle thrust to an R "Regular" Bite Throat Plate. Remove the R Throat Plate and replace with an EW or EWX (wide and extra wide). Adjust knife in cutting slot, see Page 20. Adjust cutting space.

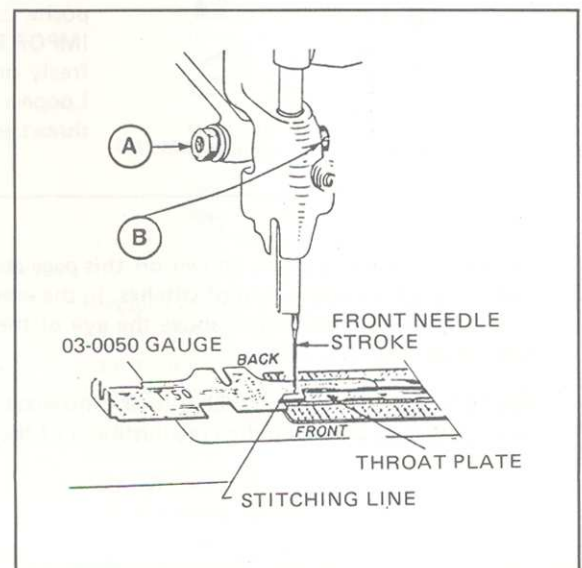

THREAD HANDLING

THREAD TAKE-UP ADJUSTMENT

Thread Take-up is adjustable for various weights or thickness of material. When Thread Take-up Lever (D) is properly adjusted, the thread slack is gradually pulled on the down stroke of the Needle by the function of Thread Guide Adjusting Plate (B) bending the thread path. Just as the Needle reaches the lowest point of its stroke, the thread slack over the entire system should be taken up.

TO ADJUST: Turn Drive Pulley by hand and observe thread action when sewing either row of stitches on regular material. If the thread becomes taut before the Needle reaches its lowest point, loosen Screws (G) and move Lever (D) down, or if slack exists in the thread at this point, move Lever (D) up until the point of correct adjustment is reached as described above. Then tighten Screws (G) securely.

THREAD TENSION ADJUSTMENT

When the Thread Take-up has been adjusted as outlined above, the firmness of the stitch setting is dependent on the degree of tension that is applied on the Thread through Tension Discs (J) and (L).

To adjust tension of the Barring Stitches, screw Nut (K) inward to tighten or outward to loosen. This, also effects the row stitches.

To adjust Tension for the Row Stitches, screw Nut (H) inward to tighten or outward to loosen. This does not effect the barring stitches.

NOTE: During the Barring Operation, the Thread Tension is only effective through Discs (L). Disc (J) automatically open when the Barring Stitches are being sewn.

TO REGULATE LENGTH OF STARTING THREAD

The amount of Thread drawn off to start the first stitch in the buttonhole is controlled by the position of Lever (F). When correctly adjusted, only a slight end of thread will protrude above the material at the first stitch and this will be covered up by the bar at the end of the buttonhole.

To adjust, loosen Nut (E) and move Lever (F) to the right for more starting thread or to the left for less starting thread. Then tighten Nut (E) securely.

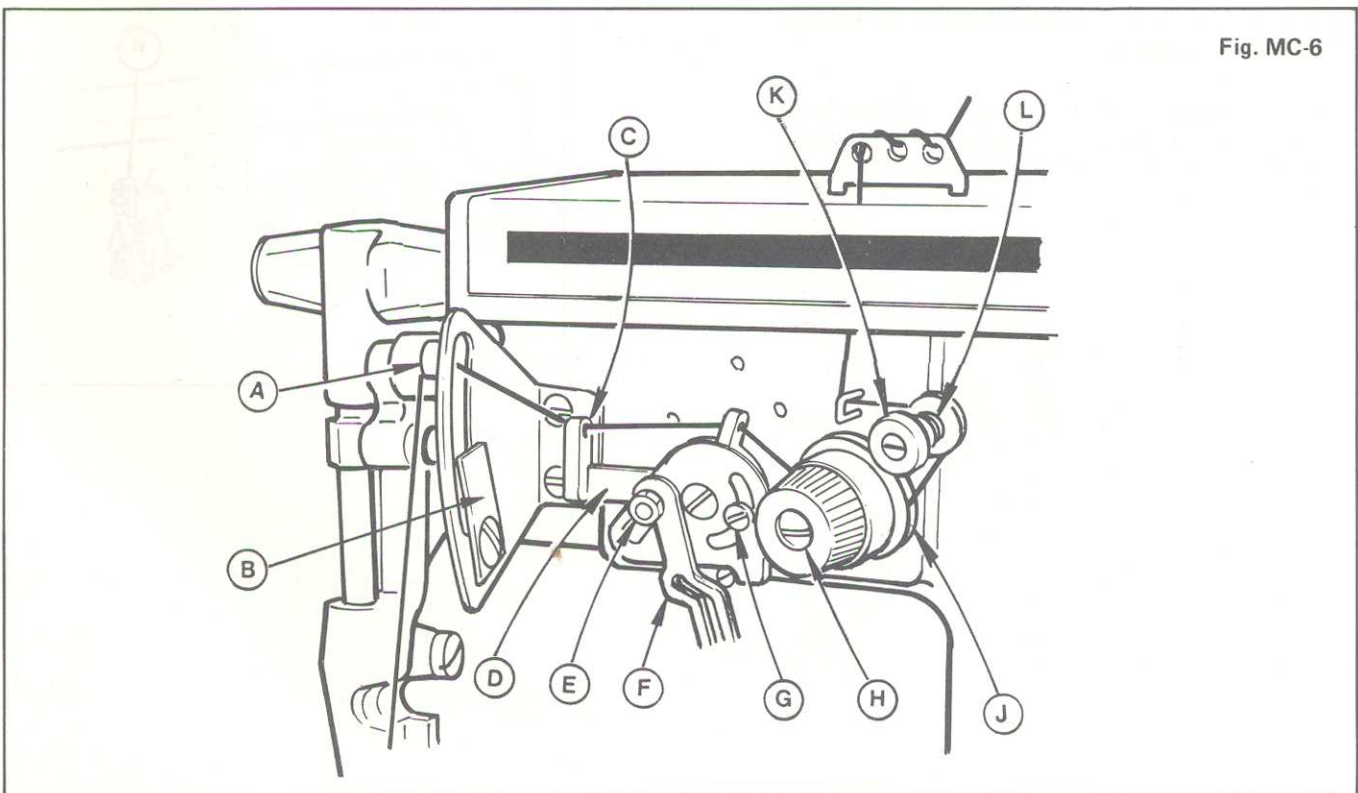
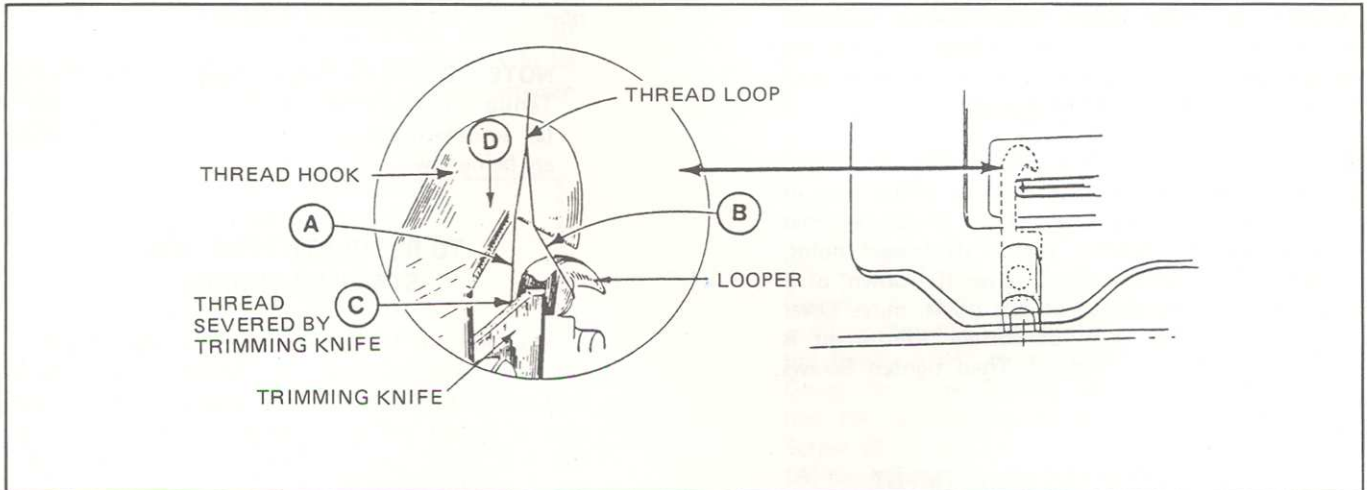

Fig. MC-6

TRIMMING

Thread trimming takes place at the completion of the last stitch in the manner illustrated in enlarged view. As the thread hook moves in the direction of Arrow (D), it pulls both legs (A) and (B) of the thread loop forward.

When the thread hook approaches the end of the stroke, leg (A) is brought into contact with the Trimming Knife causing severance of the Thread at point (C).



SHARPENING KNIFE

Whenever Knife (F) fails to sever the Thread cleanly, it should be removed and stoned to a keen edge. Trimming Knife (F) is readily accessible for removal in the following manner.

Tip the machine back on its hinges and turn Drive Pulley by hand until Loopers assume position shown. Then remove Screw (E) and Trimming Knife (F).

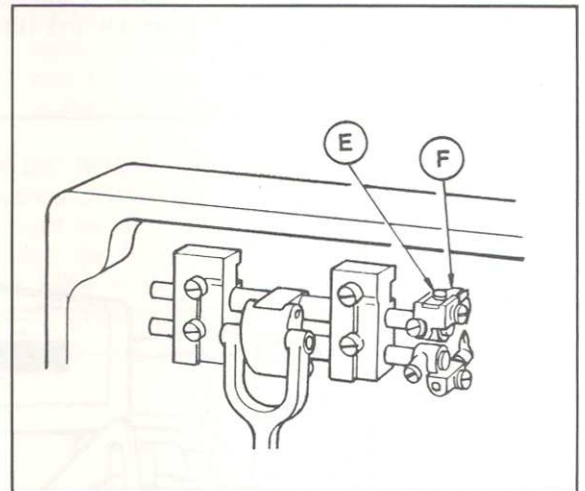

TRIMMING

TO TIME THE OPERATION OF THE THREAD HOOK

Press Stop Bolt Shaft inward until it locks. Turn Drive Pulley approximately 1/2 turn. Unlock Latch (E) so that Stop Bolt Shaft shifts back to the right. Turn Drive Pulley slowly until Pawl (J) engages the first Notch of the Vibrator Cam as shown. Loosen Screw (G) and rotate Ratchet (K) to engage Pawl (L) as shown in detail view. While maintaining this position, make sure that Member (H) is seated on the Bed Plate Boss (F)* and tighten Screw (G) securely. This setting accomplishes two objectives (1) to time the operation of the Thread Hook, and (2) to keep the Thread Hook motionless in the event of a Roll-Back of the Drive Pulley due to the Knife sticking in heavy work or failure of the Drive Pulley to carry fully through to Stop Position. Such Roll-Backs are usually the result of a loose Belt. To test the Setting; turn Drive Pulley forward a short distance and allow it to snap back to the point where Pawl (J) contacts the first Notch of the Vibrator Cam. There should be no

movement of the Thread Hook when this Roll-Back takes place.

TO POSITION THE THREAD HOOK AND THE THREAD HOOK ACTUATOR COLLAR

To position Collar (A): Loosen Screws (B) and (C). Set the Stem of Actuator (D) centrally in the hole of the Thread Hook as shown and tighten Screw (C). Oscillate Actuator (D) back and forth over its entire range to be sure that it operates freely without binding at any point. Then set Collar (A) against the side of Actuator (D) and tighten Screw (B) securely.

To position the Thread Hook: Loosen Screw (C) and swing Actuator (D) so that the point of the Thread Hook is 1/16" below the edge of the Throat Plate as shown below. While maintaining this position press the Actuator against Collar (A) and tighten Screw (B) securely.

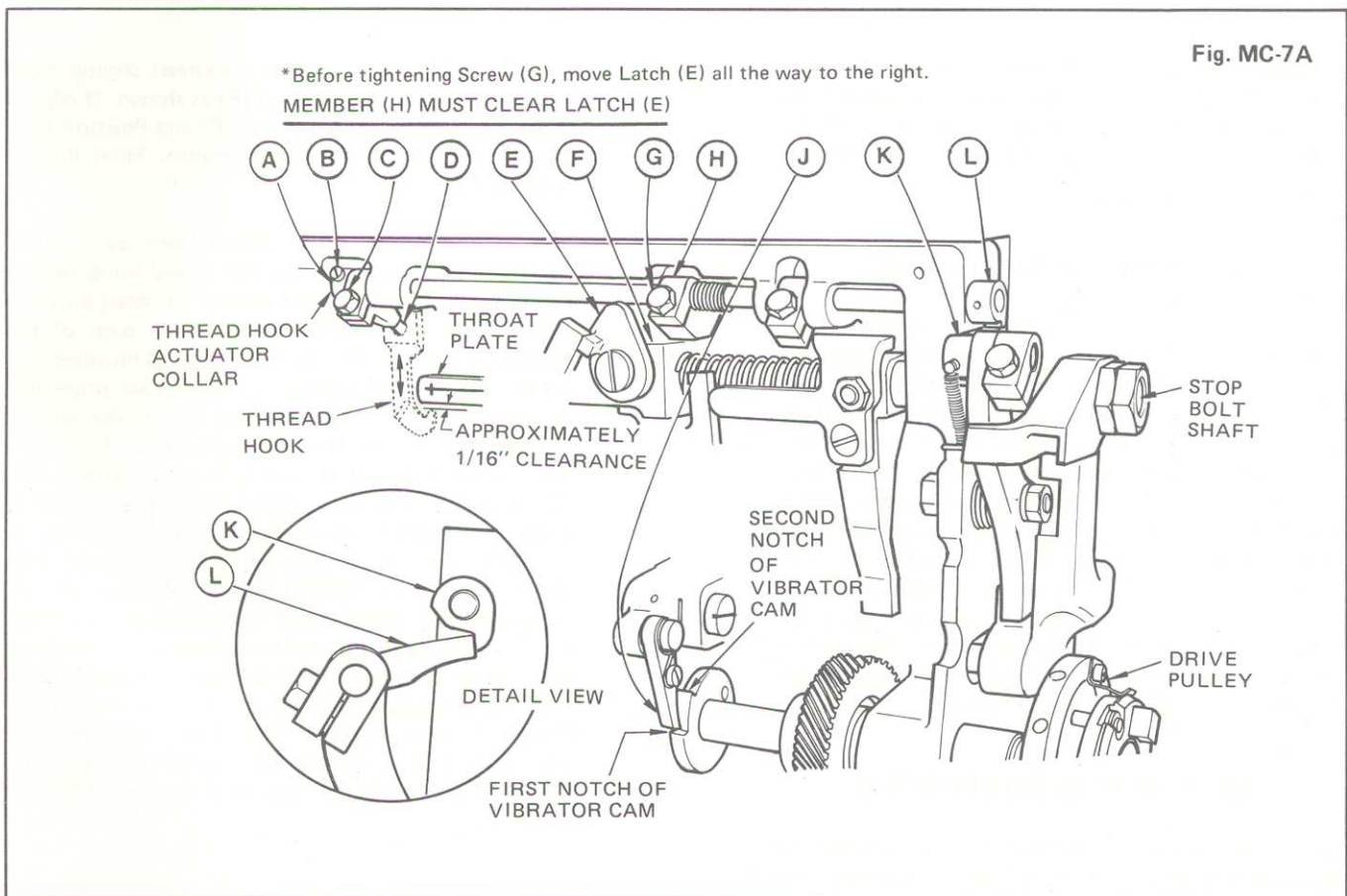

TRIMMING

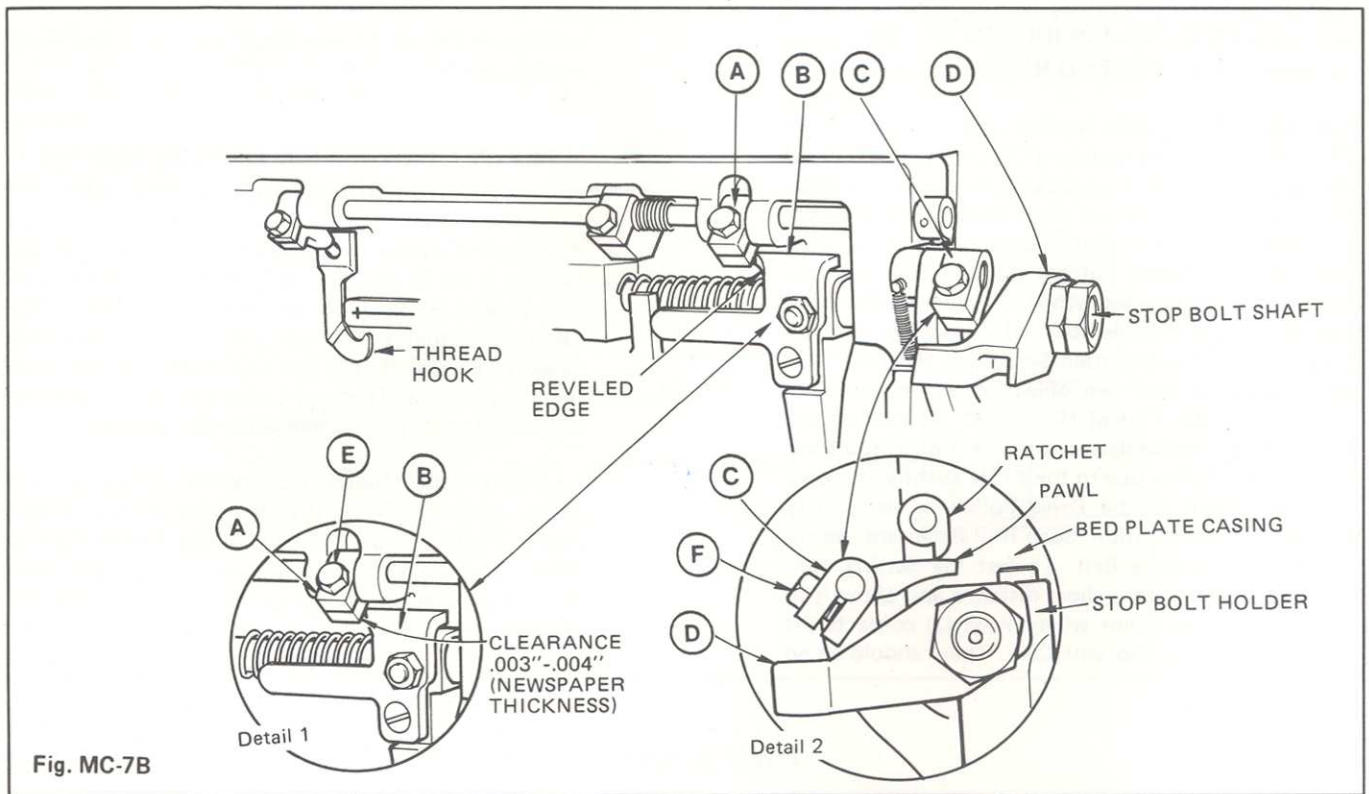

Fig. MC-7B

NOTE: Safety Arms (A) and (C) each serve individual functions as described below to prevent the Thread Hook from coming in contact with the Needle at any point of the machine's operating cycle.

ADJUSTMENT OF SAFETY ARM-C

Press Stop Bolt Shaft inward until it latches. Then with the side of the pawl contacting the ratchet as shown. Loosen Screw (F) and position Safety Arm (C) to lightly contact Actuator (D). While maintaining this position, tighten Screw (F) securely. This adjustment provides that if the machine should stop prematurely due to a loose belt or other causes leaving the ratchet and pawl in the loaded position shown, Actuator (D) as it moves inward at the start of the next operating cycle will force Safety Arm (C) upward to unlatch the pawl. This prevents the previously incompleting trimming stroke from taking place during the next sewing cycle and thus avoids possible damage to the needle or thread hook.

ADJUSTMENT OF SAFETY ARM-A

Press stop bolt holder inward until it contacts the bed plate casting. When held in this position, a clearance

of .003"-.004" (newspaper thickness) should exist between Arm (A) and Bracket (B) as shown. If adjustment is necessary, loosen Screw (E) and Position Arm (A) for the above specified clearance. Then tighten Screw (E) securely.

This setting protects the thread hook as follows: After each trimming stroke, the thread hook should spring back instantly to the normal retracted position shown so that it will be clear of the path of the needle during the next Sewing Cycle. If however, because of lack of lubrication, undue lint accumulation or other causes, the Hook should stick in the path of the needle when the machine stops, it will be forced back before the next sewing cycle starts. Safety Arm (A) in such a case will extend below the surface of Bracket (B) when the machine stops. Therefore, at the start of the next cycle, when the stop bolt shaft moves inward, the beveled edge of Bracket (B) will force Arm (A) outward and this in turn will force the thread hook back to its normal retracted position. Also, when the Stop Bolt is latched for sewing operation the members will be in the position shown (Detail 1) where Bracket (B) blocks movement of Arm (A) so that no possible contact between the Thread Hook and Needle can occur during the Sewing Cycle.