

## TABLE OF CONTENTS

---

Needle Bar .....	3-2
Clamping .....	3-4
Thread Trimmer & Material Trimming .....	3-6
Shifter Mechanism .....	3-8
Feed Mechanism .....	3-10
Looper Mechanism .....	3-14
Base .....	3-16
Bite Mechanism .....	3-18
Thread Draw-OFF mechanism .....	3-20
Main Cam .....	3-22
Head Assembly .....	3-24
Bedplate .....	3-26
Covers .....	3-28
Lubrication .....	3-30
Table .....	3-32
Electrical — I .....	3-34
Electrical — II .....	3-38
Electrical — III .....	3-40
Pneumatics — I .....	3-42
Pneumatics — II .....	3-44
Accessories .....	3-46

Released 05/2010

e-mail: [service@amfreece.cz](mailto:service@amfreece.cz); [parts@amfreece.cz](mailto:parts@amfreece.cz); website: [www.amfreece.com](http://www.amfreece.com)

Phone: +420 582 309 286; Fax: +420 582 360 606

3-1

# NEEDLE BAR

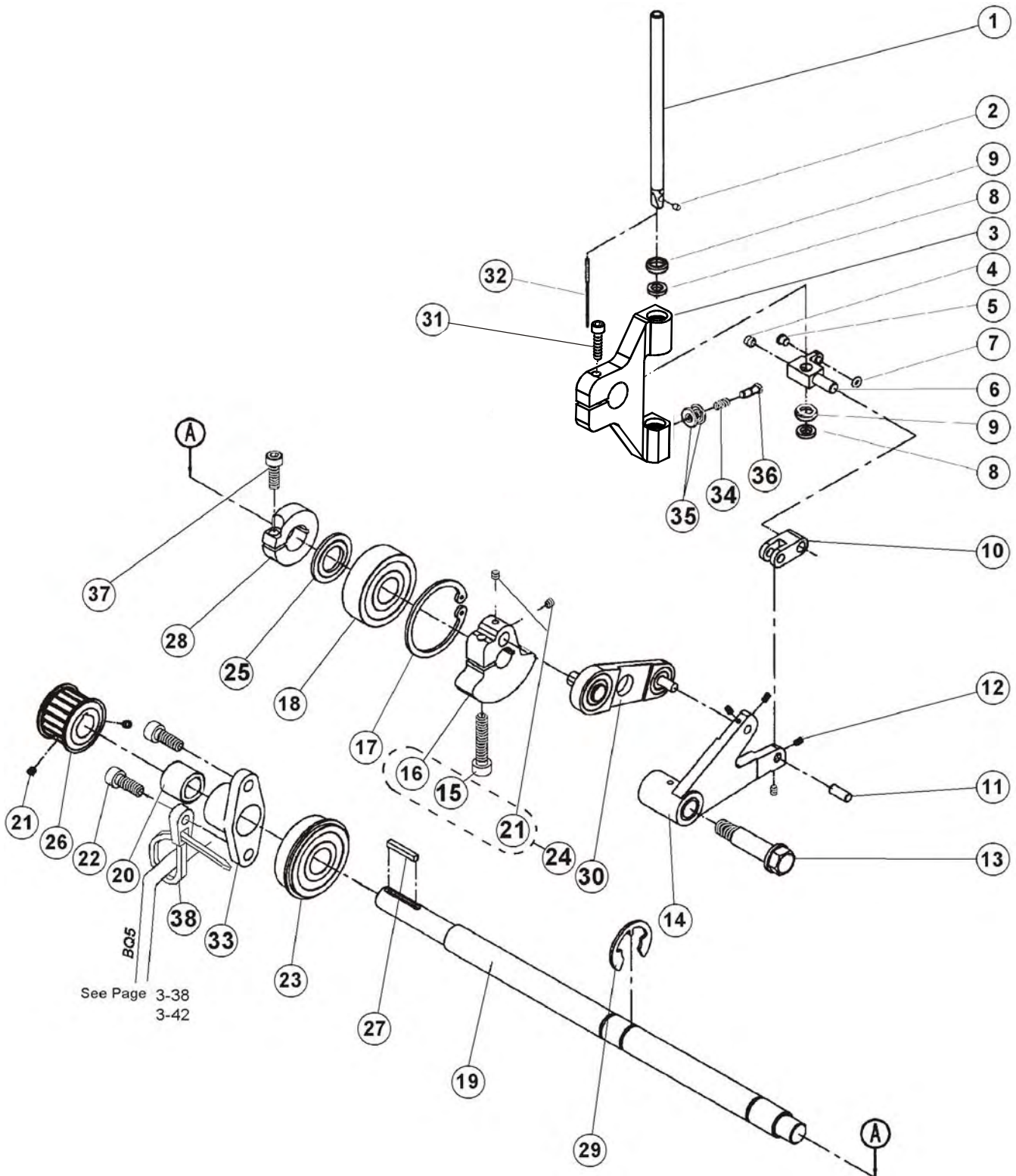

Released 05/2010

e-mail: [service@amfreece.cz](mailto:service@amfreece.cz); [parts@amfreece.cz](mailto:parts@amfreece.cz); website: [www.amfreece.com](http://www.amfreece.com)

Phone: +420 582 309 286; Fax: +420 582 360 606

## NEEDLE BAR

DET	PART NUMBER	DESCRIPTION	QTY.
01	22.0195.0.000	Needle Bar	1
02	01.2193.0.000	Screw 4-60	1
03	24.0510.0.000	Needle Bar Holder ●	1
04	08.6400.5.005	Set Screw M5 x 5	1
05	01.7447.1.000	Porcelain Guide ●●●	1
06	22.0520.0.000	Needle Bar Clamp	1
07	01.6551.0.000	Retaining Ring ●●●	1
08	22.0230.0.000	Cupped Washer ●●●	2
09	22.0239.0.000	Felt Washer	2
10	22.0530.0.000	Needle Bar Connecting Link	1
11	22.0542.0.000	Needle Bar Connecting Link Pin	1
12	08.6400.3.005	Set Screw M3 x 5	4
13	22.0541.0.000	Needle Bar Shoulder Screw	1
14	22.0540.0.000	Needle Bar Connecting Link Pin ● ●●	1
15	08.6000.6.030	Screw M6 x 30	(1)
16	22.0525.0.000	Needle Bar Crank ●	(1)
17	01.7809.0.000	Retaining Ring	1
18	01.7804.0.000	Top Shaft Bearing	1
19	24.0500.0.000	Needle Bar Drive Shaft	1
20	12.2050.0.003	Bearing	1
21	08.6400.4.004	Set Screw M4 x 4	2 (2)
22	08.6000.6.016	Screw M6 x 16	2
23	01.7805.0.000	Shaft Bearing	1
24	22.0525.0.050	Needle Bar Crank Asm.	1
25	22.0545.0.000	Washer	1
26	24.0048.0.000	Needle Bar Drive Pulley ●	1
27	22.0175.0.000	Drive Shaft Key	1
28	24.0002.0.000	Clamp Collar	1
29	12.1045.2.001	Retaining Ring	1
30	22.0535.0.100	Needle Bar Crank Link Asm. ●	1
31	08.6000.6.025	Screw M6 x 25	1
32	02.0750.2.109	Needle	1
33	24.0001.0.000	Bearing Carrier Upper Shaft	1
34	22.0178.0.000	Spring	1
35	22.0177.0.000	Washer	2
36	24.0100.0.000	Screw M3.5 x 0.35-11	1
37	08.6000.5.016	Screw M5 x 16	1
38	12.0010.4.013	Cord Clamp	1

Released 05/2010

e-mail: [service@amfreece.cz](mailto:service@amfreece.cz); [parts@amfreece.cz](mailto:parts@amfreece.cz); website: [www.amfreece.com](http://www.amfreece.com)

Phone: +420 582 309 286; Fax: +420 582 360 606

# CLAMPING

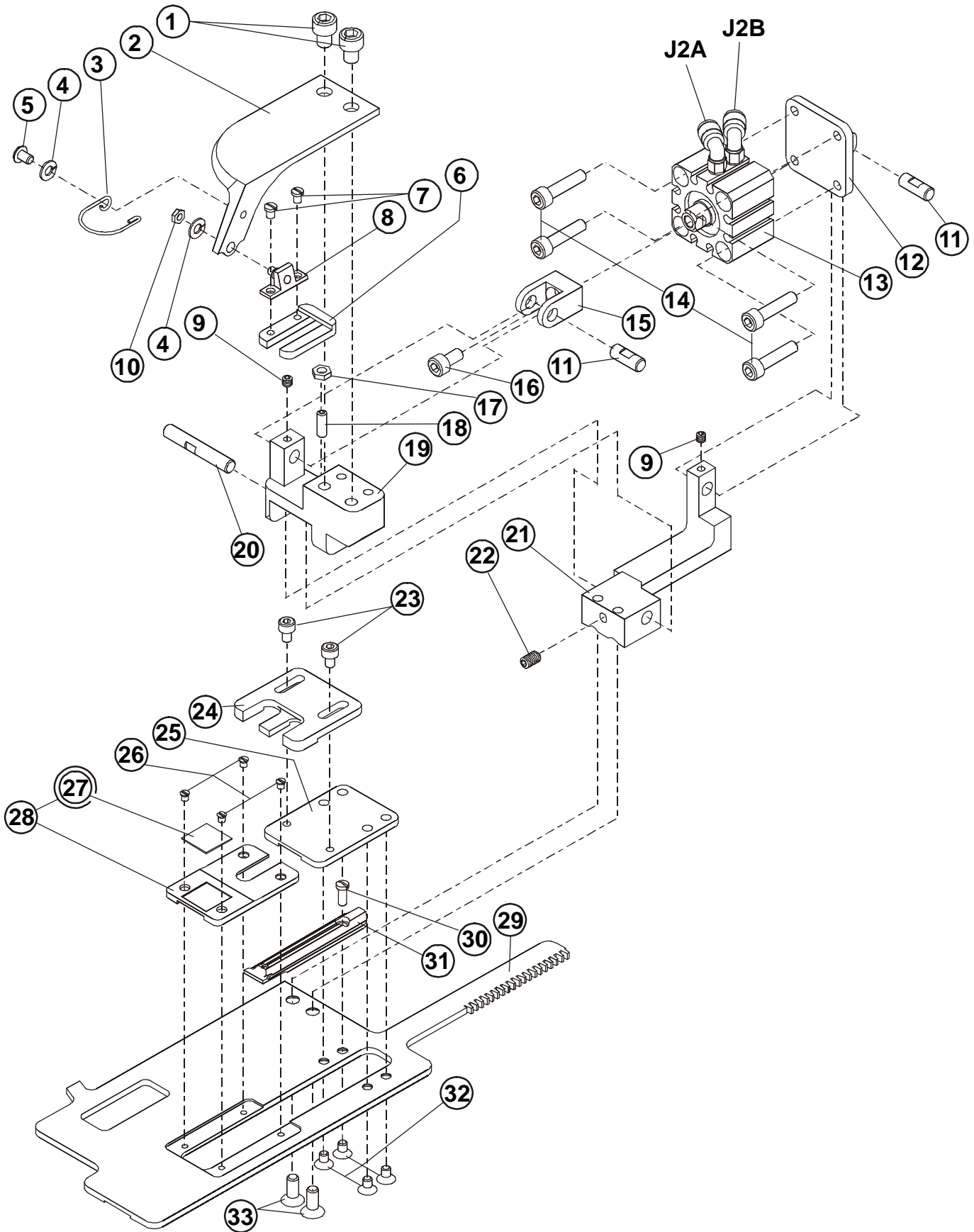

Released 05/2010

e-mail: [service@amfreece.cz](mailto:service@amfreece.cz); [parts@amfreece.cz](mailto:parts@amfreece.cz); website: [www.amfreece.com](http://www.amfreece.com)

Phone: +420 582 309 286; Fax: +420 582 360 606

## CLAMPING

DET	PART NUMBER	DESCRIPTION	QTY.
01	08.6000.6.010	Screw M6 x 10	2
02	24.3305.0.000	Clamp Arm	1
03	24.3306.0.000	Needle Guard	1
04	08.6800.4.000	Lock Washer ● ● ● ●	2
05	08.6200.4.006	Screw M4 x 6	1
06	24.3304.0.000	Clamp Foot	1
07	01.2563.0.000	Screw # 6-52	2
08	22.3251.0.000	Bracket Assembly	1
09	08.6400.4.004	Set Screw M4 x 4	2
10	22.0179.0.000	Nut M3,5	1
11	22.0173.0.000	Clamp Toggle Pivot Pin	2
12	24.0036.1.000	Cylinder Mounting Bracket	1
13	See Page 3-43	Cylinder	—
14	08.6000.5.022	Screw M5 x 22	4
15	24.0035.1.000	Cylinder Clevis	1
16	08.6000.5.012	Screw M5 x 12	1
17	08.6700.4.000	Nut M4	1
18	08.6400.4.012	Set Screw M4 x 12	1
19	24.3026.0.000	Tail Pivot Clamp	1
20	22.0159.0.000	Tail Pivot Clamp Pin	1
21	24.0158.1.000	Tail Bracket Clamp	1
22	08.6400.5.008	Set Screw M5 x 10	1
23	08.6000.4.006	Screw M4 x 6	2
24	24.3303.0.000	Material Guide	1
25	24.3301.0.000	Holder	1
26	01.2376.0.000	Screw # 4-60	4
27	12.0008.4.604	Reflex Tape	(1)
28	24.3302.0.000	Clmping Mat	1
29	22.3028.0.000	Clamp Plate	1
30	01.2084.0.000	Fill. Screw # 6-52	1
31	24.3310.0.000	Throat Plate LT	1
32	08.6100.4.006	Screw M4 x 6	4
33	08.6100.5.012	Screw M5 x 12	2

Released 05/2010

e-mail: [service@amfreece.cz](mailto:service@amfreece.cz); [parts@amfreece.cz](mailto:parts@amfreece.cz); website: [www.amfreece.com](http://www.amfreece.com)

Phone: +420 582 309 286; Fax: +420 582 360 606

# THREAD TRIMMER & MATERIAL TRIMMING

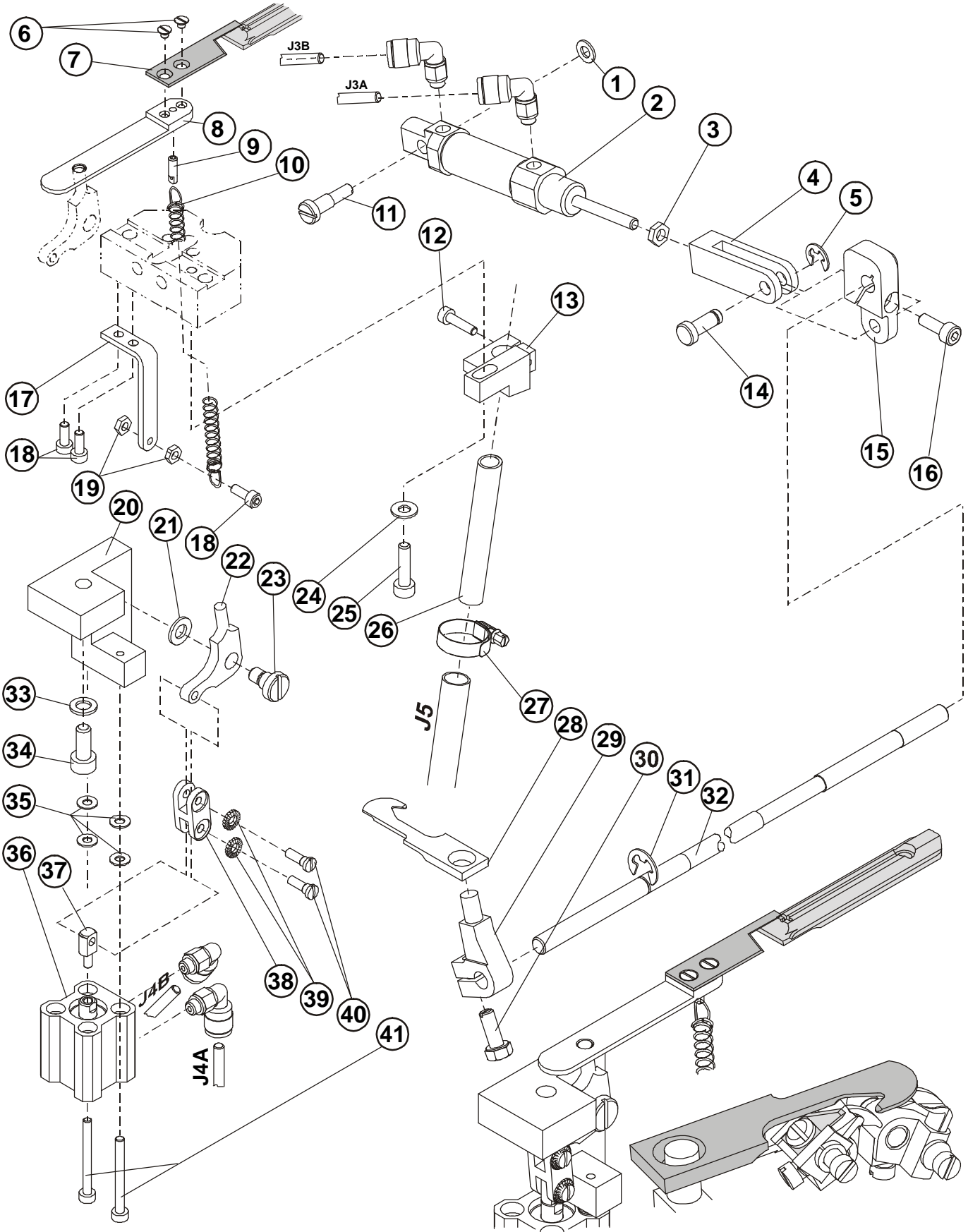

**THREAD TRIMMER & MATERIAL TRIMMING**

DET	PART NUMBER	DESCRIPTION	QTY.
01	08.6850.4.000	Washer	1
02	See Page 3-43	Trimmer Cylinder	—
03	08.6700.4.000	Nut M4	1
04	24.0005.0.000	Clevis	1
05	07.6045.0.042	E-Clip	1
06	08.6117.7.004	Screw M2,5 x 4	2
07	24.3311.0.000	Knife	1
08	24.3312.0.000	Knife Holder	1
09	24.3313.0.000	Hinge Spring	1
10	01.5602.0.000	Spring	1
11	24.0006.0.000	Pivot Screw	1
12	08.6000.3.012	Screw M3 x 12	1
13	24.3320.0.000	Holder Tubbing	1
14	24.0003.0.000	Trimmer Pivot	1
15	24.0004.0.000	Trimmer Clamp Lever	1
16	08.6000.4.012	Screw M4 x 12	1
17	24.3321.0.000	Holder Spring	1
18	08.6000.3.008	Screw M3 x 8	3
19	08.6700.3.000	Nut M3	2
20	24.3314.0.000	Holder, Knife Cylinder	1
21	08.6887.5.000	Washer M5	1
22	24.3315.0.000	Trimmer Actuator	1
23	22.0182.0.000	Shoulder Screw	1
24	08.6850.4.000	Washer	1
25	08.6000.4.016	Screw M4 x 16	1
26	24.3319.0.000	Tubing, Material Absorb	1
27	12.0008.6.251	Air Tubing Clamp	1
28	24.3309.0.000	Trimmer Hook	1
29	20.0092.0.004	Trimmer Actuator	1
30	01.2386.0.000	Hex Screw 3/16-36 x .5	1
31	12.1045.3.001	E-Clip	1
32	24.0080.0.000	Trimmer Shaft	1
33	08.6800.5.000	Lockwasher M5	1
34	08.6000.5.012	Screw M5 x 12	1
35	08.6850.3.000	Washer M3	5
36	See Page 3-43	Cylinder	—
37	24.3317.0.000	Cylinder Clevis	1
38	24.3316.0.000	Connecting Link	1
39	17.0019.5.040	Washer M3,5	2
40	17.0013.5.067	Shoulder Screw	2
41	08.6000.3.040	Screw M3 x 40	2

Released 05/2010

e-mail: [service@amfreece.cz](mailto:service@amfreece.cz); [parts@amfreece.cz](mailto:parts@amfreece.cz); website: [www.amfreece.com](http://www.amfreece.com)

Phone: +420 582 309 286; Fax: +420 582 360 606

# SHIFTER MECHANISM

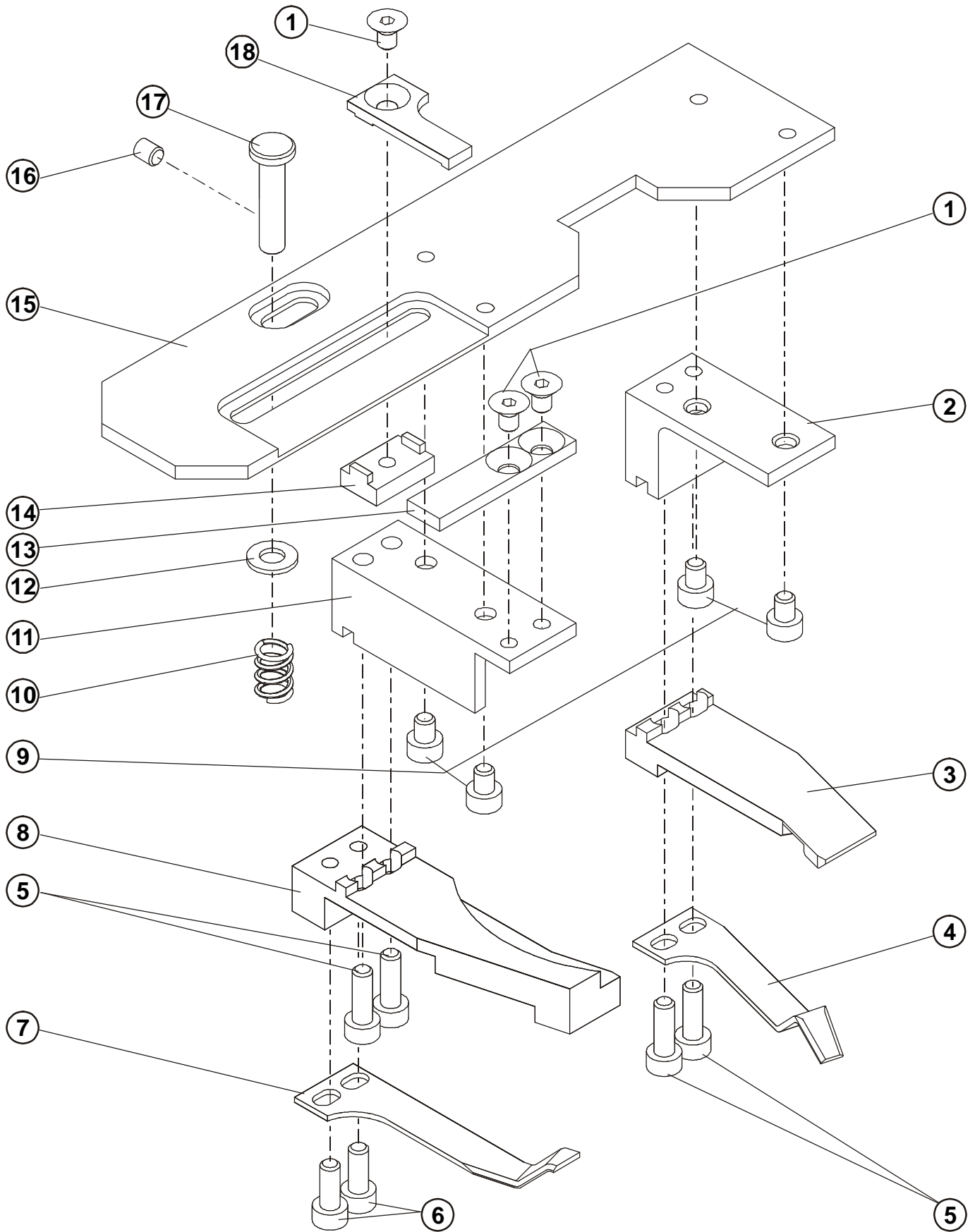

Released 05/2010

e-mail: [service@amfreece.cz](mailto:service@amfreece.cz); [parts@amfreece.cz](mailto:parts@amfreece.cz); website: [www.amfreece.com](http://www.amfreece.com)

Phone: +420 582 309 286; Fax: +420 582 360 606





# FEED MECHANISM

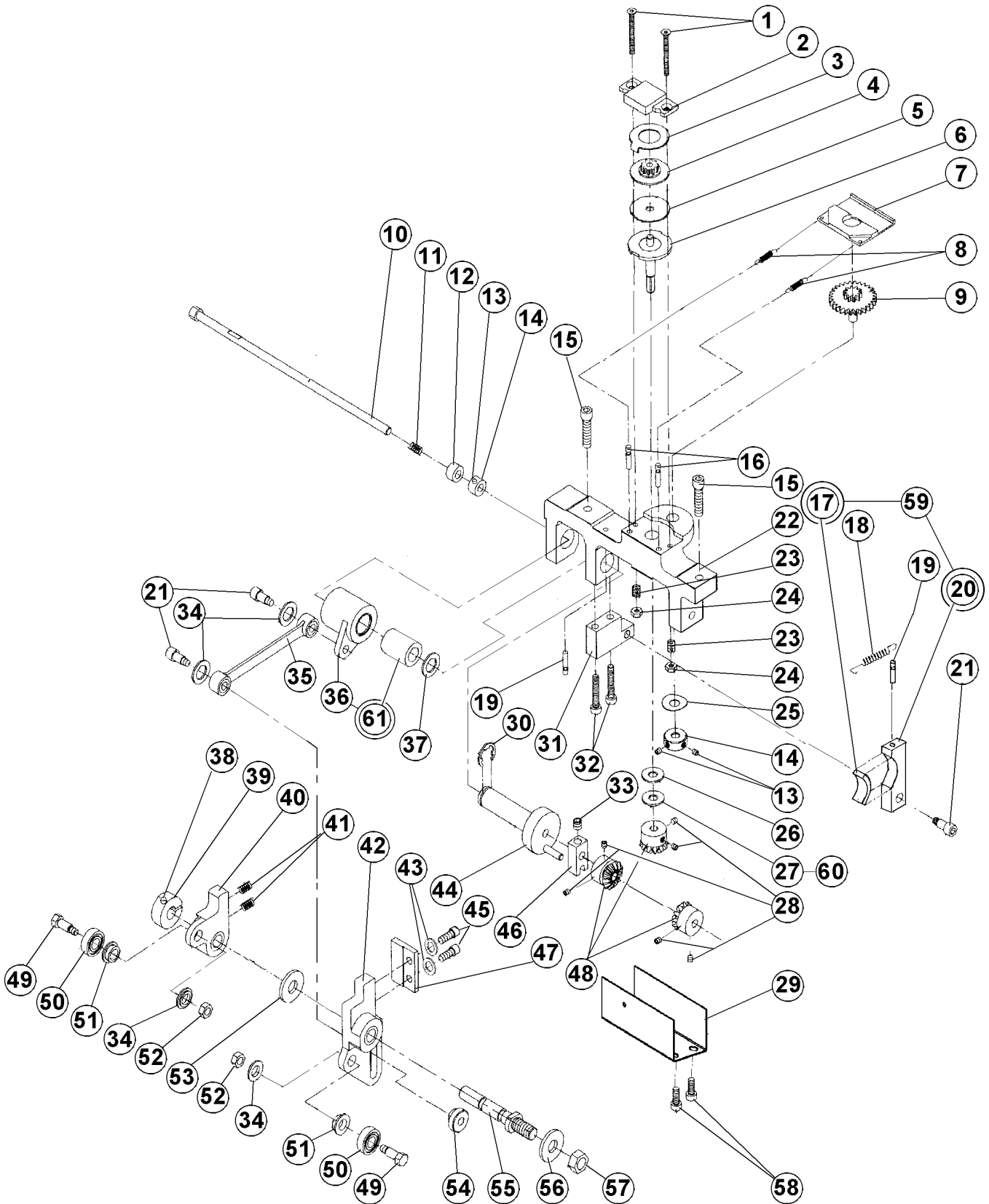

Released 05/2010

e-mail: [service@amfreece.cz](mailto:service@amfreece.cz); [parts@amfreece.cz](mailto:parts@amfreece.cz); website: [www.amfreece.com](http://www.amfreece.com)

Phone: +420 582 309 286; Fax: +420 582 360 606

## FEED MECHANISM

DET	PART NUMBER	DESCRIPTION	QTY.
01	08.6100.3.030	Screw M3 x 30	2
02	22.0114.0.000	Feed Brake Pressure Plate	1
03	22.0121.0.000	Slip Clutch Drive Washer	1
04	22.0354.0.000	Slip Clutch Feed Gear	1
05	24.0126.0.000	Friction Washer ●●●	1
06	22.0312.0.000	Slip Clutch Feed Shaft	1
07	22.0061.0.000	Clamp Plate Gear Rack Retainer	1
08	07.6440.0.033	Spring	2
09	24.0351.0.000	Feed Gear Assembly	1
10	22.0325.0.000	Feed Reversing Shaft	1
11	07.6440.0.041	Spring	1
12	22.0228.0.000	Collar	1
13	08.6400.5.305	Set Screw M5 x 0,5 - 5	4
14	24.0049.0.000	Set Collar	2
15	08.6000.5.020	Screw M5 x 20	2
16	07.6045.0.037	Grooved Pin 3 x 16	2
17	22.0313.0.000	Feed Brake Pad ●●●	(1)
18	07.6440.0.050	Spring	1
19	07.6045.0.009	Pin 3 x 12	2
20	22.0309.0.000	Feed Brake	(1)
21	22.0184.0.000	Screw M5 x 8	3
22	22.0315.0.000	Feed Shaft Bracket ●●	1
23	07.6440.0.028	Spring	2
24	08.6733.3.000	Lock Nut M3	2
25	17.0019.2.057	Lockwasher	1
26	22.0208.0.000	Flat Washer	1
27	22.0186.0.000	Washer Dia. 5.2/17-0.2	1
28	08.6400.4.005	M4 x 5 Set Screw	6
29	24.2035.0.000	Gear Cover	1
30	07.6045.0.034	E-Ring	1
31	22.0049.0.000	Feed Brake Mounting Block ●	1
32	08.6000.4.025	Screw M4 x 25	2
33	08.6400.5.005	Set Screw M5 x 5	1
34	22.0100.0.000	Shoulder Washer	4
35	22.0305.0.000	Feed Connecting Link ●●●	1
36	22.0320.0.000	Feed Shaft Bearing Housing	1
37	17.0019.0.517	Washer	1
38	08.6000.3.010	Screw M3 x 10	1
39	22.0183.0.000	Collar Dia. 8	1
40	22.0026.0.000	L.H. Feed Cam Follower ●●●	1
41	07.6440.0.018	Spring	2
42	24.0127.0.000	R.H. Feed Cam Follower ●●●	1
43	08.6800.4.000	M4 Lockwasher	2
44	22.0336.0.000	Feed Shaft	1
45	08.6000.4.014	Screw M4 x 14	2
46	22.0370.0.000	Feed Crank	1
47	22.0021.0.000	Spring Retain Block	1
48	22.0353.0.000	Steel Bevel Gear ●	3
49	22.0032.0.000	Bearing Shoulder Screw	2
50	07.6321.0.025	Bearing	2

Released 05/2010

e-mail: [service@amfreece.cz](mailto:service@amfreece.cz); [parts@amfreece.cz](mailto:parts@amfreece.cz); website: [www.amfreece.com](http://www.amfreece.com)

Phone: +420 582 309 286; Fax: +420 582 360 606



# FEED MECHANISM

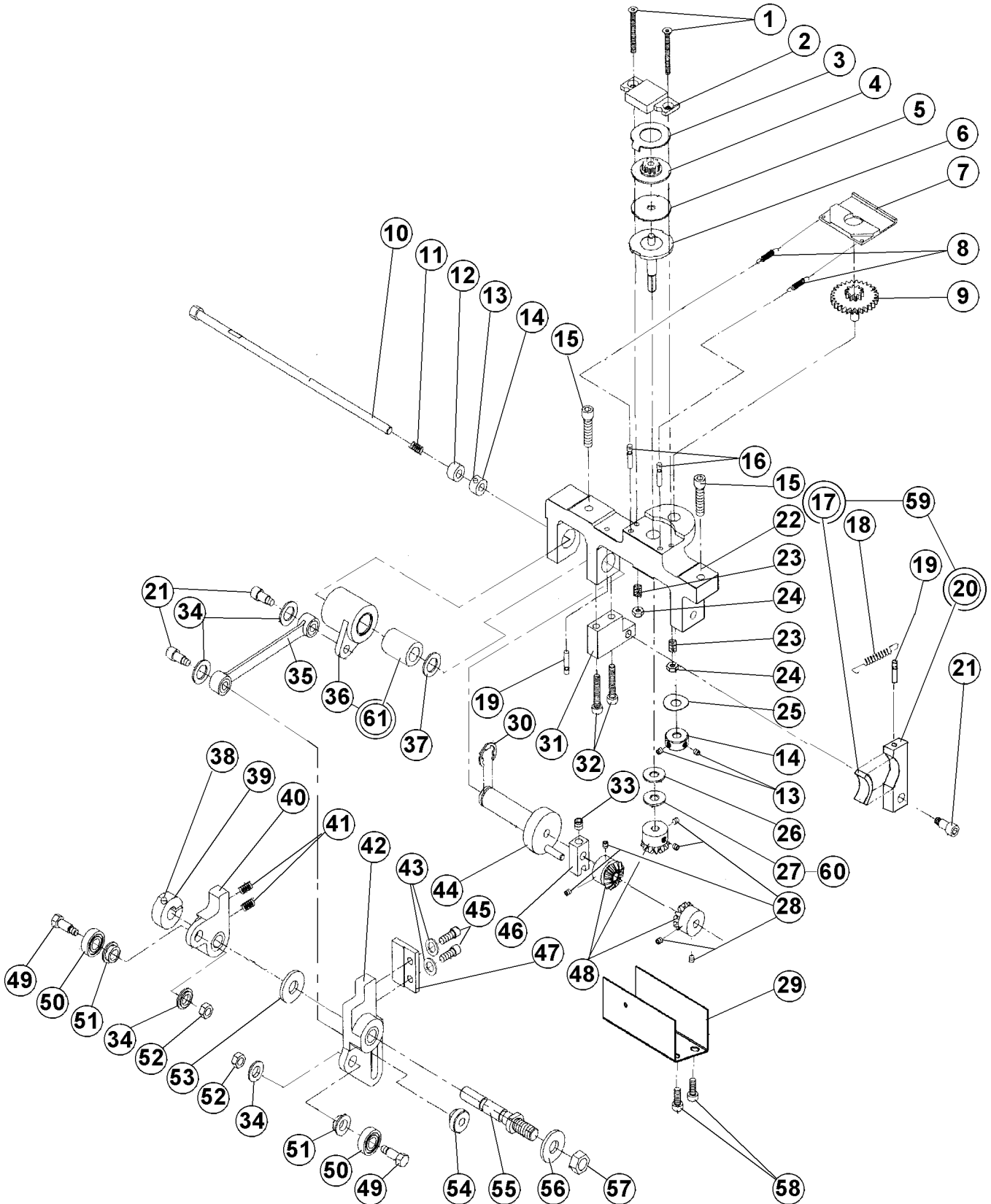

Released 05/2010

e-mail: [service@amfreece.cz](mailto:service@amfreece.cz); [parts@amfreece.cz](mailto:parts@amfreece.cz); website: [www.amfreece.com](http://www.amfreece.com)

Phone: +420 582 309 286; Fax: +420 582 360 606



# LOOPER MECHANISM

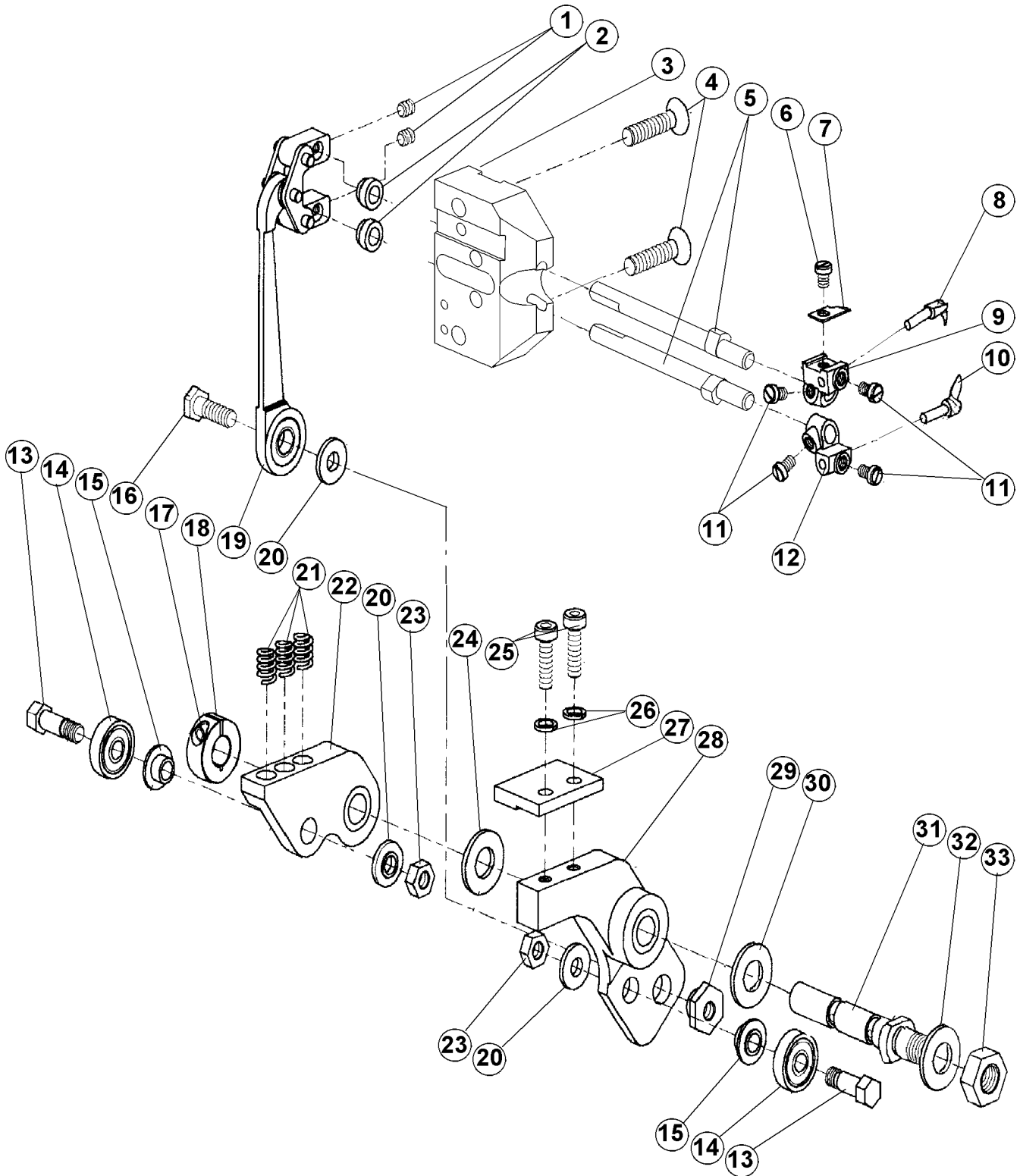

## LOOPER MECHANISM

DET	PART NUMBER	DESCRIPTION	QTY.
01	08.6400.4.004	Set Screw M4 x 4	2
02	22.2442.0.000	Looper Spacer	2
03	24.3321.0.000	Looper Shaft Block	1
04	08.6100.5.020	Screw M5 x 20	2
05	24.3322.0.000	Looper Shaft	2
06	01.1382.0.000	Screw	1
07	20.0094.0.000	Trimmer Knife	1
08	20.0111.0.000	First Looper	1
09	23.2106.0.000	First Looper Holder	1
10	20.0112.0.000	Second Looper	1
11	01.1397.0.000	Screw	4
12	23.2107.0.000	Second Looper Holder	1
13	24.0066.0.000	Bearing Screw	2
14	12.2010.1.002	Cam Follower Bearing	2
15	22.0031.0.000	Bearing Spacer	2
16	22.0064.0.000	Bite Shoulder Screw	1
17	08.6000.3.010	Screw M3 x 10	1
18	22.0183.0.000	Collar	1
19	22.2425.0.050	Looper Link Assembly	1
20	22.0100.0.000	Shoulder Washer	3
21	07.6440.0.036	Spring	3
22	22.0024.0.000	Looper Cam Follower Plate ● ● ●	1
23	08.6710.5.000	Hex Nut M5	2
24	22.0232.0.000	Flat Washer	1
25	08.6000.4.014	Screw M4 x 14	2
26	08.6800.4.000	Lockwasher M4	2
27	22.0021.0.000	Spring Retainer Block	1
28	22.0023.0.000	R.H. Looper Cam Follower Plate ● ● ●	1
29	22.0105.0.000	Looper Eccentric Nut	1
30	22.0233.0.000	Flat Washer	1
31	22.0022.0.000	Pivot Shaft	1
32	08.6850.8.000	Flat Washer M8	1
33	08.6700.8.000	Hex Nut M8	1

Released 05/2010

e-mail: [service@amfreece.cz](mailto:service@amfreece.cz); [parts@amfreece.cz](mailto:parts@amfreece.cz); website: [www.amfreece.com](http://www.amfreece.com)

Phone: +420 582 309 286; Fax: +420 582 360 606

3-15

# BASE

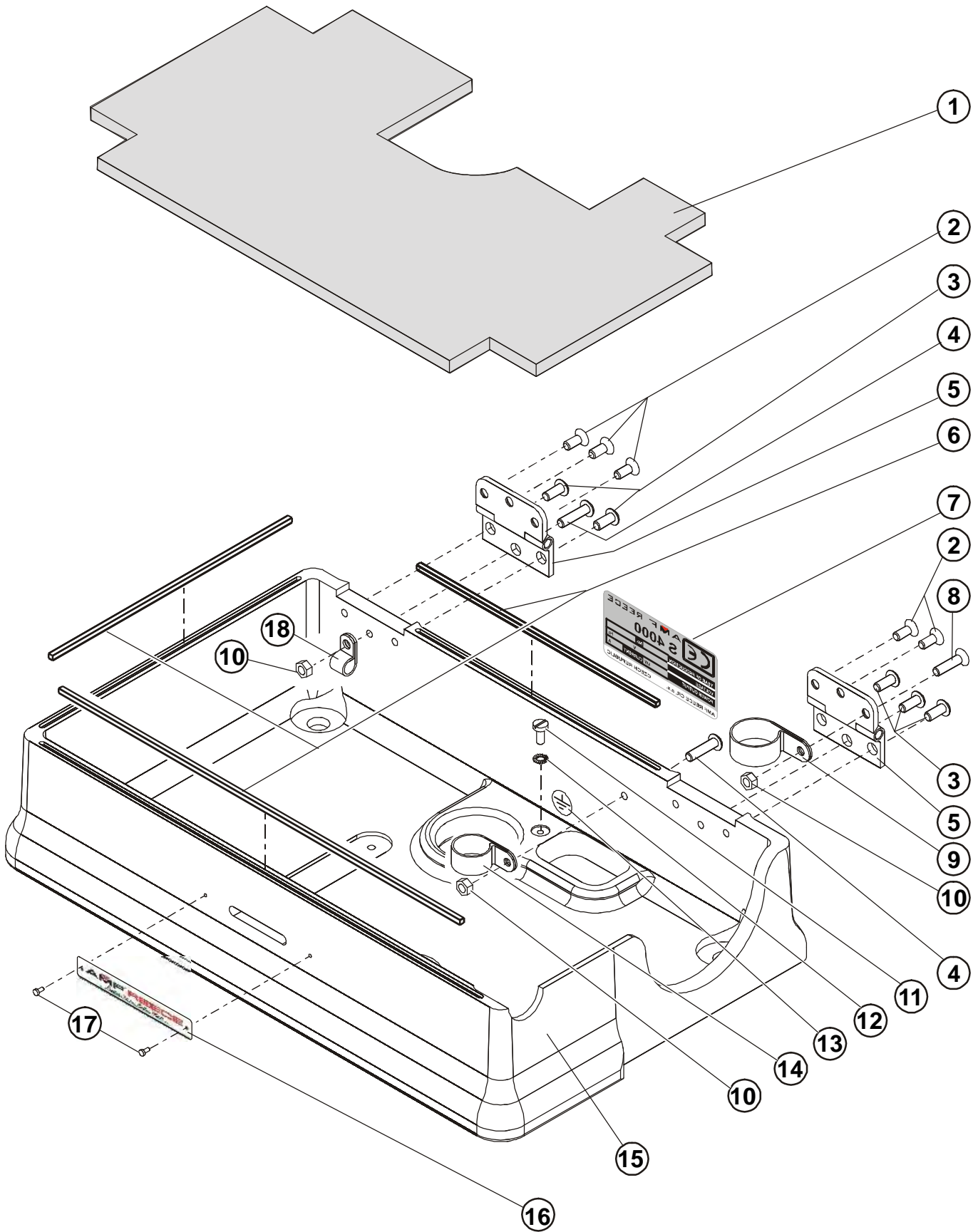

Released 05/2010

e-mail: [service@amfreece.cz](mailto:service@amfreece.cz); [parts@amfreece.cz](mailto:parts@amfreece.cz); website: [www.amfreece.com](http://www.amfreece.com)

Phone: +420 582 309 286; Fax: +420 582 360 606





# BITE MECHANISM

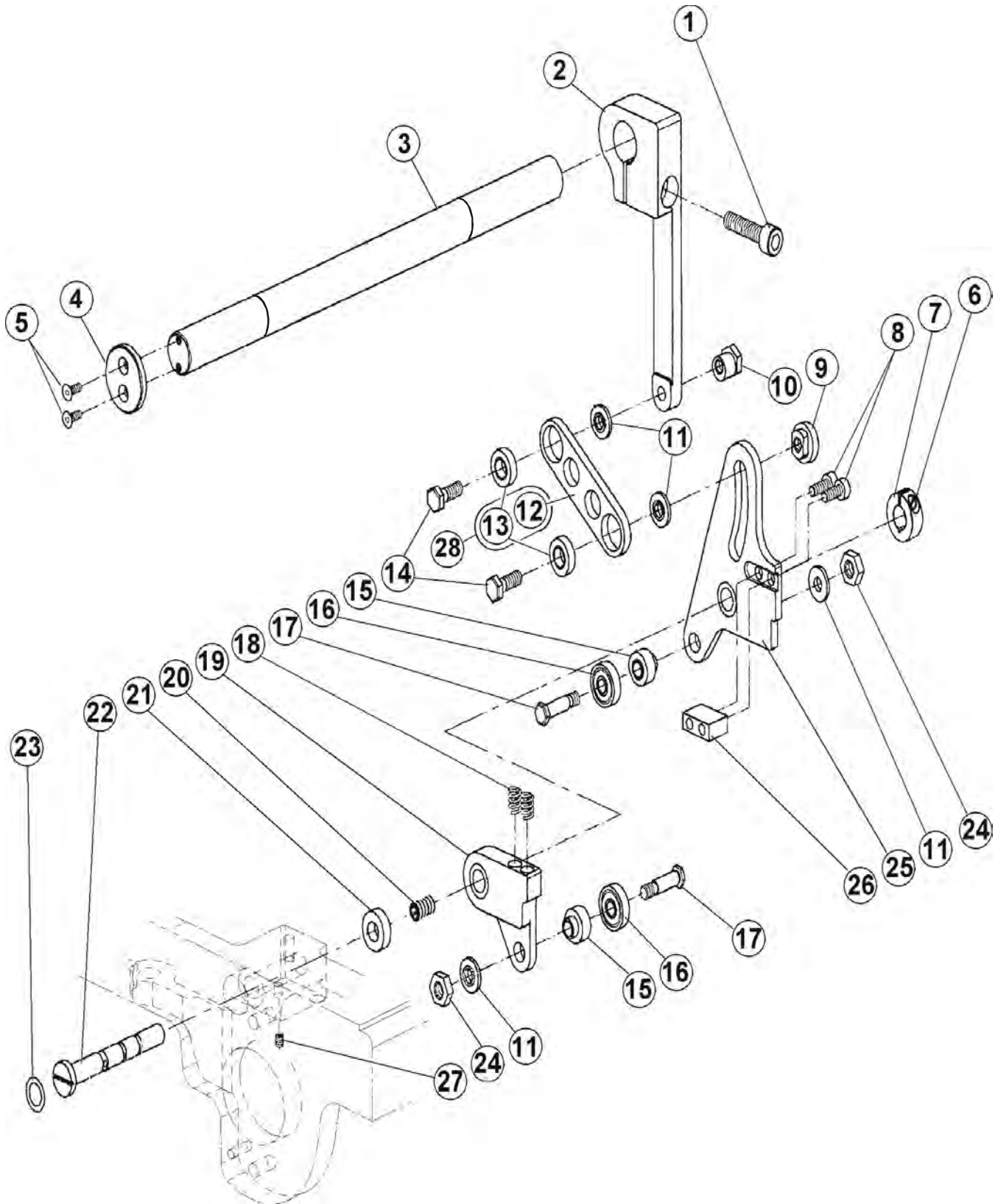

Released 05/2010

e-mail: [service@amfreece.cz](mailto:service@amfreece.cz); [parts@amfreece.cz](mailto:parts@amfreece.cz); website: [www.amfreece.com](http://www.amfreece.com)

Phone: +420 582 309 286; Fax: +420 582 360 606

## BITE MECHANISM

DET	PART NUMBER	DESCRIPTION	QTY.
01	08.6000.6.025	Screw M6 x 25	1
02	22.0008.0.000	Bite Lever ●	1
03	24.0055.0.000	Bite Shaft	1
04	22.0063.0.000	Bite Shaft Retainer	1
05	08.6100.3.008	FH Screw M3 x 8	2
06	08.6000.3.010	Screw M3 x 10	1
07	22.0183.0.000	Collar*Dia. 8	1
08	08.6000.4.014	Screw M4 x 14	2
09	22.0110.0.000	Shoulder Nut M5	1
10	22.0214.0.000	Eccentric Nut M5	1
11	22.0100.0.000	Shoulder Washer	4
12	22.0009.0.000	Bite Adjusting Link ●	(1)
13	07.6321.0.029	Bearing	(2)
14	22.0064.0.000	Bite Shoulder Screw	2
15	22.0029.0.000	Bite Follower Bearing Spacer	2
16	07.6321.0.025	Bearing	2
17	22.0028.0.000	Bite Follower Bearing Screw	2
18	07.6440.0.028	Spring	2
19	22.0027.0.000	Right Cam Follower ● ● ●	1
20	08.6400.4.005	Set Screw M4 x 5	1
21	22.0069.0.000	Bite Follower Spacer	1
22	22.0020.0.000	Bite Pivot Shaft	1
23	12.0008.6.800	Rubber Ring ● ● ●	1
24	08.6700.5.000	Hex Nut M5	2
25	22.0033.0.000	Left Cam Follower ● ● ●	1
26	22.0030.0.000	Bite Follower Spring Retainer	1
27	08.6400.4.004	Screw M4x4	1
28	22.0009.0.050	Bite Adjusting Link Assembly	1

Released 05/2010



e-mail: [service@amfreece.cz](mailto:service@amfreece.cz); [parts@amfreece.cz](mailto:parts@amfreece.cz); website: [www.amfreece.com](http://www.amfreece.com)

Phone: +420 582 309 286; Fax: +420 582 360 606

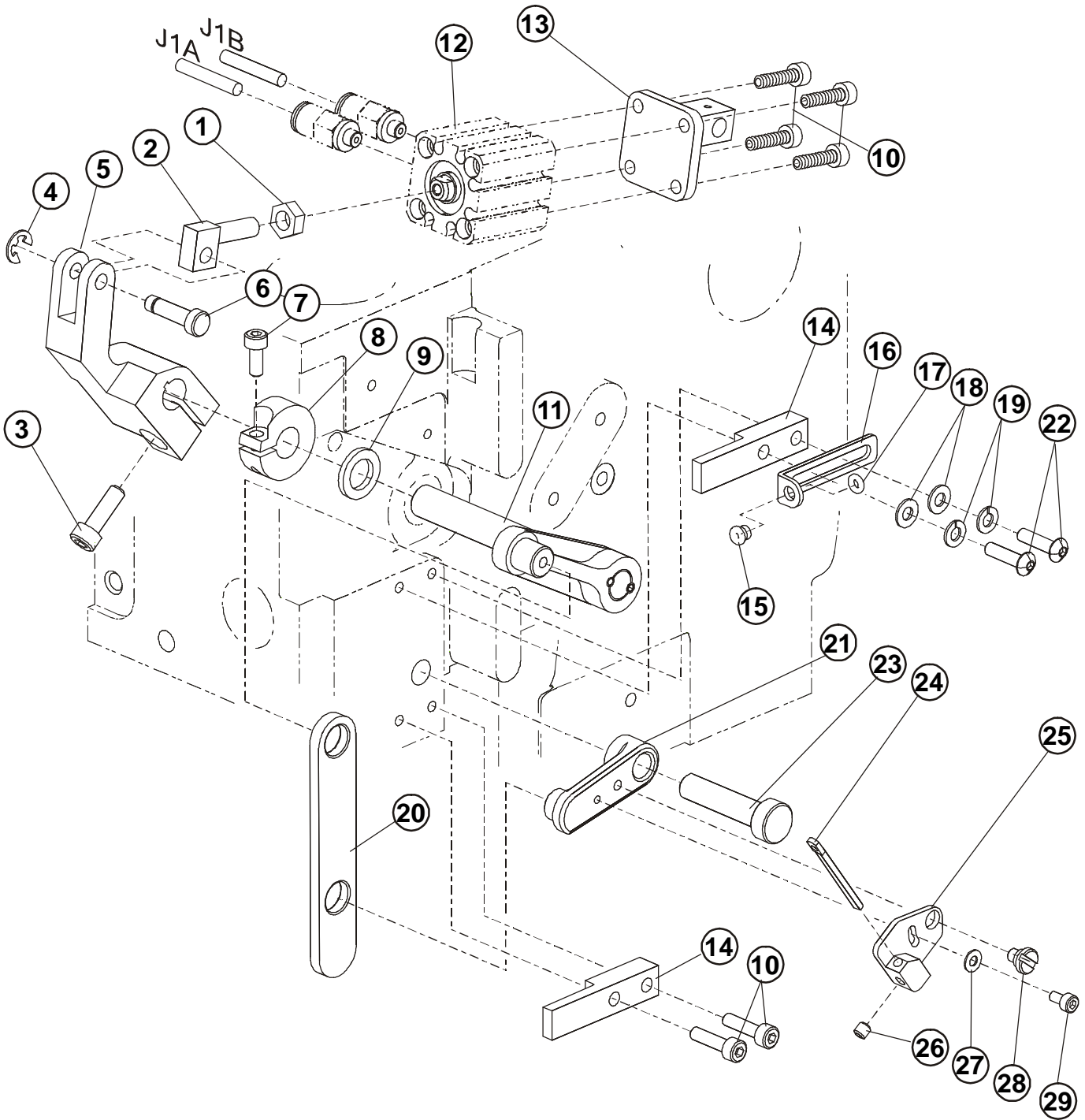
# THREAD DRAW-OFF MECHANISM



**THREAD DRAW-OFF MECHANISM**

DET	PART NUMBER	DESCRIPTION	QTY.
01	08.6710.6.000	Nut M6 	1
02	24.0037.0.000	Cylinder Clevis 	1
03	08.6000.5.016	Screw M5 x 16	1
04	07.6045.0.042	E-Clip	1
05	24.0011.0.000	Knife Drive Lever	1
06	24.0014.0.000	Pivot	1
07	08.6000.4.010	Screw M4 x 10	1
08	24.0010.0.000	Clamp Collar	1
09	24.0009.0.000	Washer	1
10	08.6000.4.016	Screw M4 x 16	6
11	22.1415.0.050	Knife Lever Assembly	1
12	See Page 3-43	Thread Draw-Off Cylinder	—
13	24.0039.1.000	Thread Draw-Off Bracket	1
14	22.1436.0.000	Drive Plate Retainer 	2
15	01.7447.1.000	Porcelain Guide	1
16	22.0046.0.000	Thread Guide Bracket	1
17	01.6551.0.000	Retaining Ring	1
18	08.6850.4.000	Flat Washer M4	2
19	08.6800.4.000	Lockwasher M4	2
20	24.1430.1.000	Drive Plate	1
21	24.0062.0.000	Knife Guide Link	1
22	08.6200.4.016	Screw M4 x 16	2
23	22.0161.0.000	Pivot Eccentric	1
24	22.0091.0.000	Thread Take-Up	1
25	24.0063.0.000	Thread Draw-Off	1
26	08.6400.4.004	Set Screw M4 x 4	1
27	08.6850.3.000	Washer M3	1
28	24.0061.0.000	Shoulder Screw	1
29	08.6000.3.006	Screw M3 x 6	1

Released 05/2010

e-mail: [service@amfreece.cz](mailto:service@amfreece.cz); [parts@amfreece.cz](mailto:parts@amfreece.cz); website: [www.amfreece.com](http://www.amfreece.com)

Phone: +420 582 309 286; Fax: +420 582 360 606

# MAIN CAM

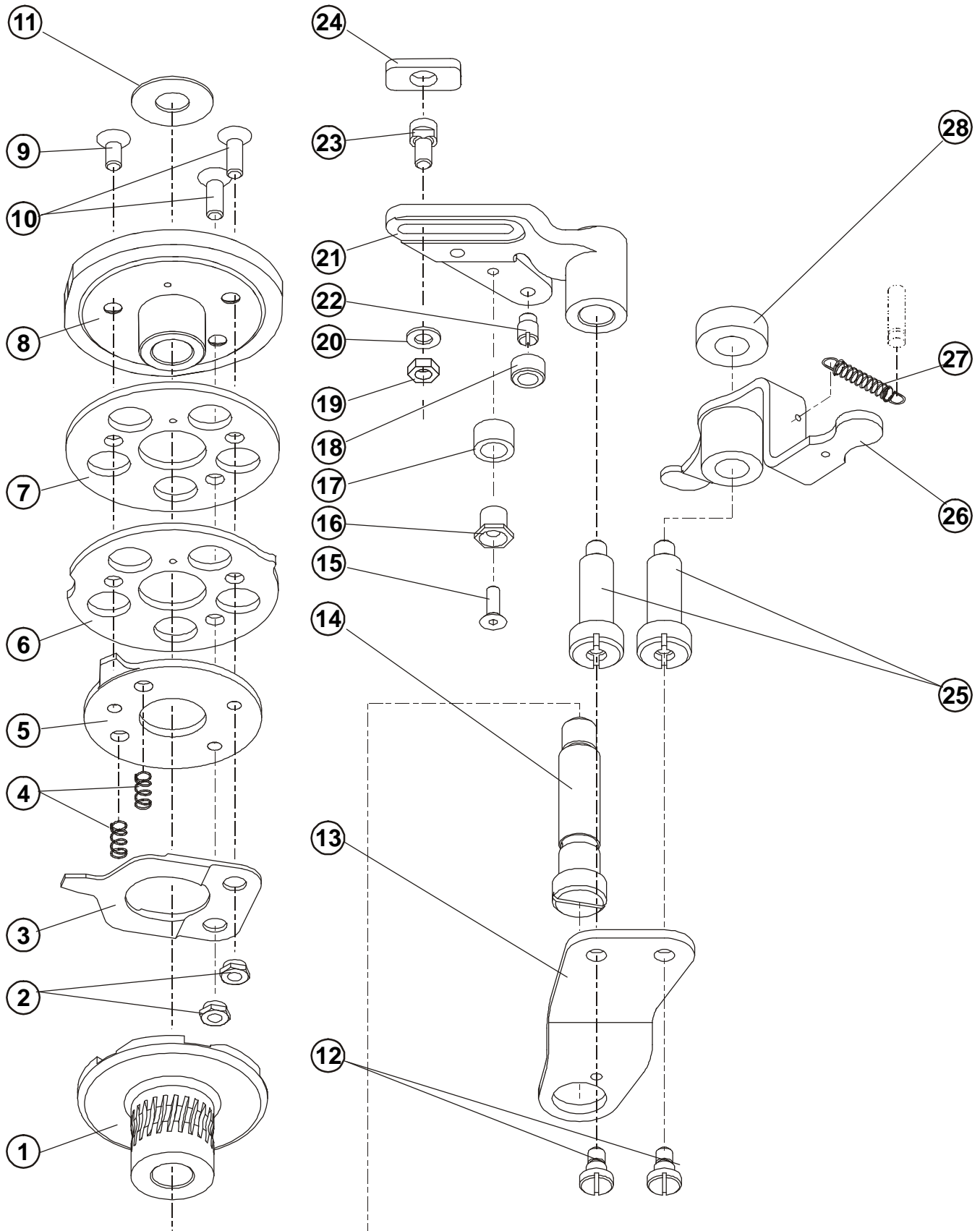



# HEAD ASSEMBLY

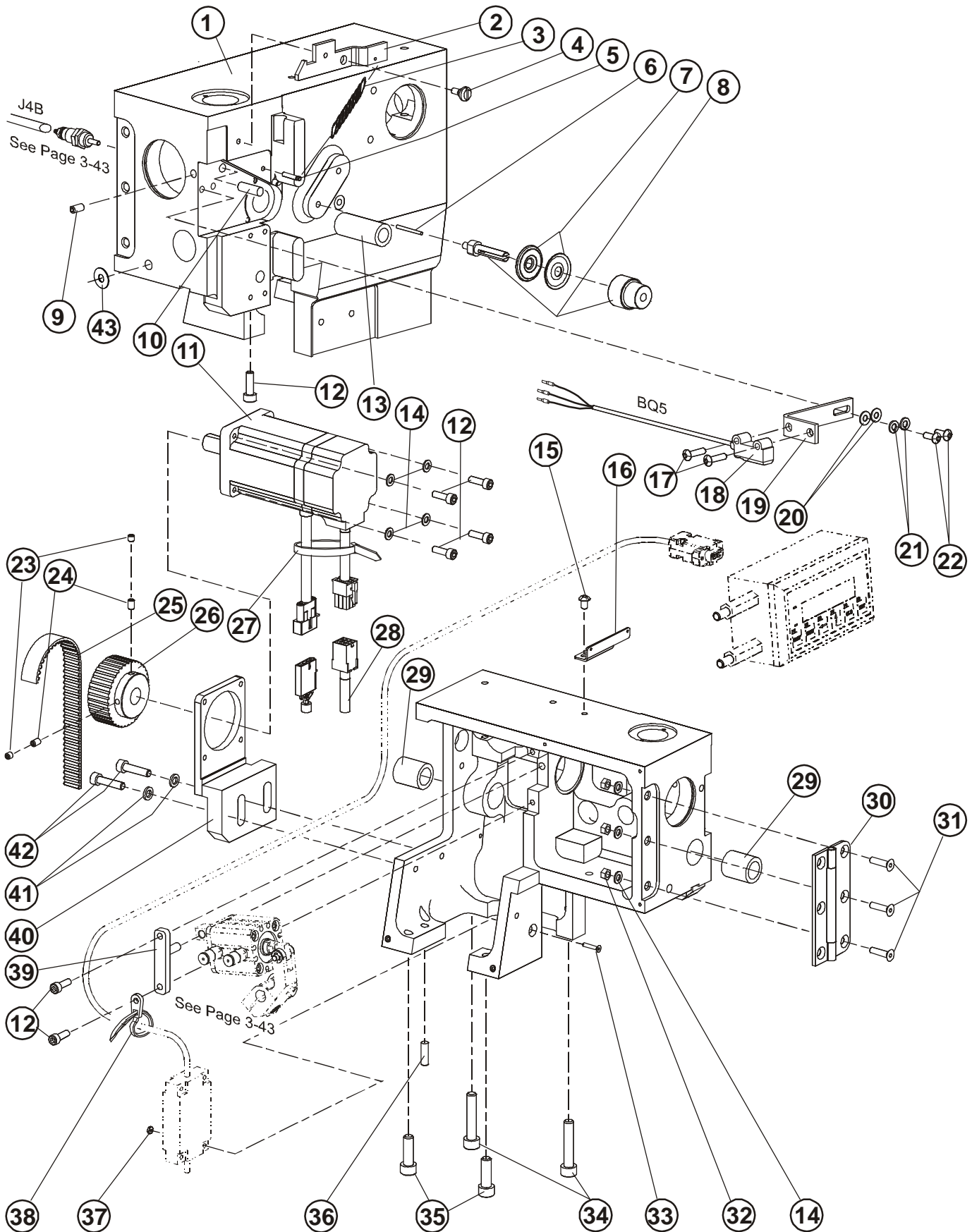

Released 05/2010

e-mail: [service@amfreece.cz](mailto:service@amfreece.cz); [parts@amfreece.cz](mailto:parts@amfreece.cz); website: [www.amfreece.com](http://www.amfreece.com)

Phone: +420 582 309 286; Fax: +420 582 360 606



## HEAD ASSEMBLY

DET	PART NUMBER	DESCRIPTION	QTY.
01	24.6000.5.000	Head	1
02	22.0058.0.000	Sewing Head Latch	1
03	07.6440.0.051	Latch Tension Spring	1
04	22.0062.0.000	Screw M4 x 3	1
05	07.6045.0.037	Grooved Pin 3 x 16	1
06	12.1010.2.003	Pin 2 x 24	1
07	17.0082.8.082	Release Washer	1
08	24.0119.0.050	Large Tension Assembly	●●● 1
09	08.6400.5.010	Screw M5 x 10	1
10	07.6045.0.053	Pin 6 x 20	1
11	See Page 3-35	Servomotor	● ●● ●●● 1
12	08.6000.5.016	Screw M5 x 16	8
13	22.1422.0.000	Knife Shaft Bushing	1
14	08.6850.5.000	Washer M5	7
15	08.6200.5.008	Screw M5 x 8	1
16	22.0054.0.000	Upper Thread Guide	1
17	08.6200.3.012	Screw M3 x 12	2
18	24.0069.9.037	Sensor BQ5 Assembly	1
19	24.3324.0.000	Bracket, Optical Sensor	1
20	08.6850.3.000	Washer	2
21	08.6800.3.000	Lock Washer	2
22	08.6200.3.012	Screw	2
23	08.6400.5.005	Set Screw M5 x 5	2
24	08.6400.5.008	Set Screw M5x8	2
25	12.5050.2.009	Belt	●●● 1
26	24.0108.0.000	Motor Pulley	● 1
27	12.0008.3.023	Ty-wrap	● 1
28	See Page 3-35	Encoder Cable	●●● ●●● 1
29	01.7806.0.000	Oilite Bushing	●● 2
30	22.6002.0.000	Head Hinge Assembly	1
31	08.6100.5.020	Screw M5 x 20	3
32	08.6700.5.000	Nut M5	3
33	08.6100.3.016	Screw M3 x 16	1
34	08.6000.8.040	Screw M8x40	2
35	08.6000.8.025	Screw M8 x 25	2
36	12.1011.0.001	Pin 6 x 20	1
37	08.6700.3.000	Nut M3	1
38	12.0008.4.598	Plastic Cable Fitting	●●● 1
39	24.0016.0.000	Cylinder Pivot Stud Assembly	1
40	24.0106.0.000	Motor Bracket	1
41	08.6850.6.000	Washer M6	2
42	08.6000.6.025	Screw M6 x 25	2
43	01.4980.0.000	Bearing AS 0821	1

Released 27/2012

e-mail: [service@amfreece.cz](mailto:service@amfreece.cz); [parts@amfreece.cz](mailto:parts@amfreece.cz); website: [www.amfreece.com](http://www.amfreece.com)

Phone: +420 582 309 286; Fax: +420 582 360 606

# BEDPLATE

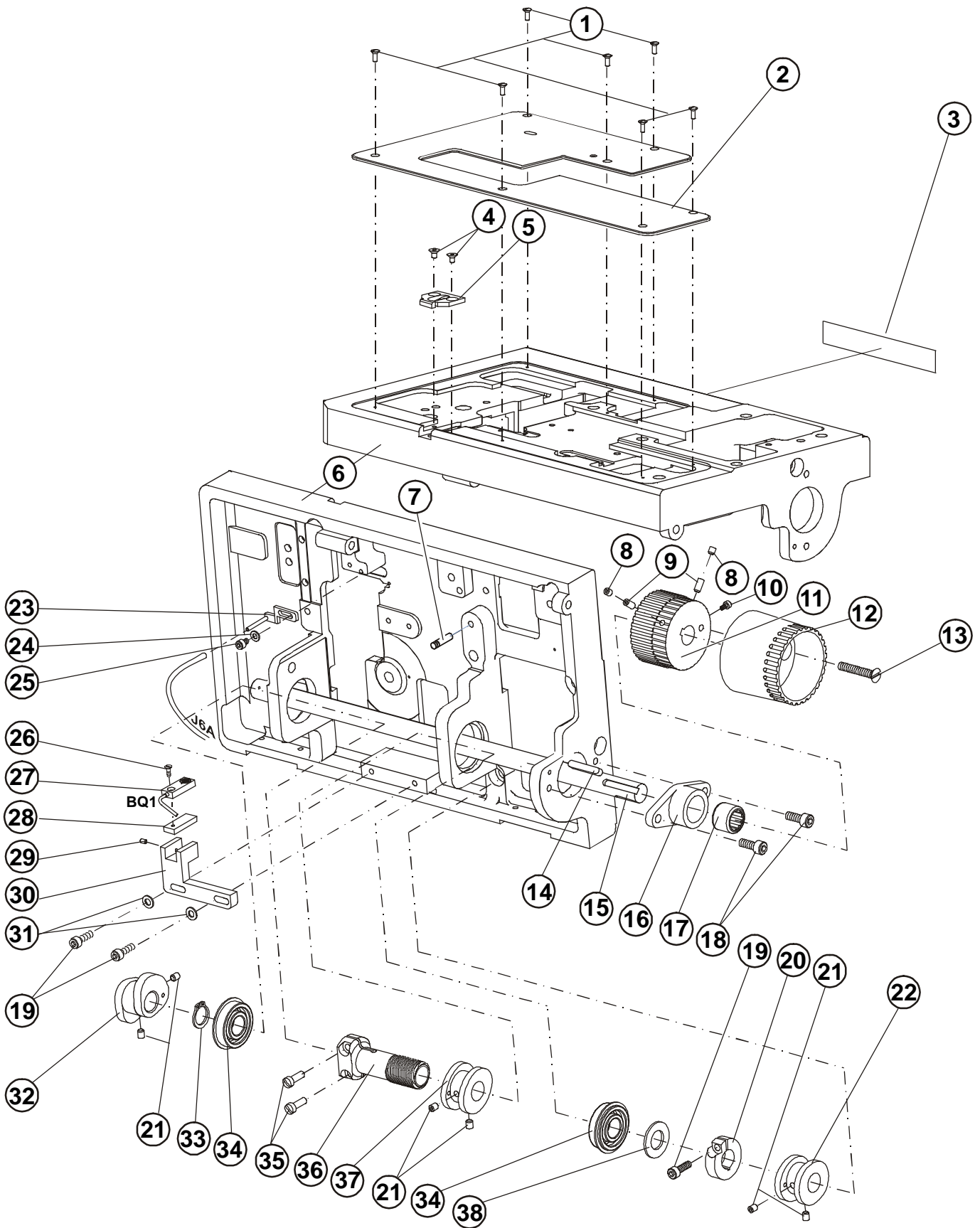

Released 05/2010

e-mail: [service@amfreece.cz](mailto:service@amfreece.cz); [parts@amfreece.cz](mailto:parts@amfreece.cz); website: [www.amfreece.com](http://www.amfreece.com)

Phone: +420 582 309 286; Fax: +420 582 360 606

## BEDPLATE

DET	PART NUMBER	DESCRIPTION	QTY.
01	08.6120.3.008	Screw M3x8	7
02	24.3300.0.000	Cover Plate	1
03	05.1394.0.000	AMF Reece Label - small	1
04	08.6100.4.006	Screw M4x6	2
05	22.0408.1.000	Trimmer Cover Plate	1
06	24.6100.1.000	Bedplate ISBH	1
07	07.6045.0.054	Pin 5 x 20	1
08	08.6400.5.005	Set Screw M5 x 5	2
09	08.6400.5.010	Set Screw M5 x 10	2
10	08.6000.3.006	Screw M3 x 6	1
11	24.0018.0.000	Main Shaft Drive Pulley	● 1
12	24.0051.0.066	Hand Wheel	● 1
13	08.6100.6.035	Screw M6 x 35	1
14	12.4030.0.002	Key 5x5x30	1
15	24.1000.0.000	Main Shaft	1
16	24.0019.0.000	Bearing Carrier Lower Shaft	1
17	12.2050.0.005	Bearing	1
18	08.6000.6.016	Screw M6 x 16	2
19	08.6000.5.016	Screw M5 x 16	3
20	24.0002.0.000	Clamp Collar	1
21	08.6400.5.305	Set Screw M5 x 0.5-5	6
22	22.0006.0.000	Bite Cam	1
23	24.3318.0.000	Blow-Off Assembly	1
24	08.6850.4.000	Washer M4	1
25	08.6000.4.006	Screw M4 x 6	1
26	08.6100.3.008	Screw M3 x 8	1
27	See Page 3-35	End of Cycle Sensor with Cable	●●● —
28	24.0027.0.000	Sensor Mounting Plate	1
29	08.6400.3.004	Set Screw M3 x 4	1
30	24.0020.0.000	End of Cycle Sensor Bracket	1
31	08.6850.5.000	Washer M5	2
32	24.2400.0.000	Looper Cam	1
33	12.1045.2.001	Retaining Ring	1
34	01.7805.0.000	Shaft Bearing	2
35	22.0153.0.000	Screw	2
36	22.8400.0.000	Shaft Worm Gear	1
37	22.0300.0.000	Feed Cam	1
38	22.0545.0.000	Washer	1

Released 05/2010

e-mail: [service@amfreece.cz](mailto:service@amfreece.cz); [parts@amfreece.cz](mailto:parts@amfreece.cz); website: [www.amfreece.com](http://www.amfreece.com)

Phone: +420 582 309 286; Fax: +420 582 360 606

3-27





# LUBRICATION

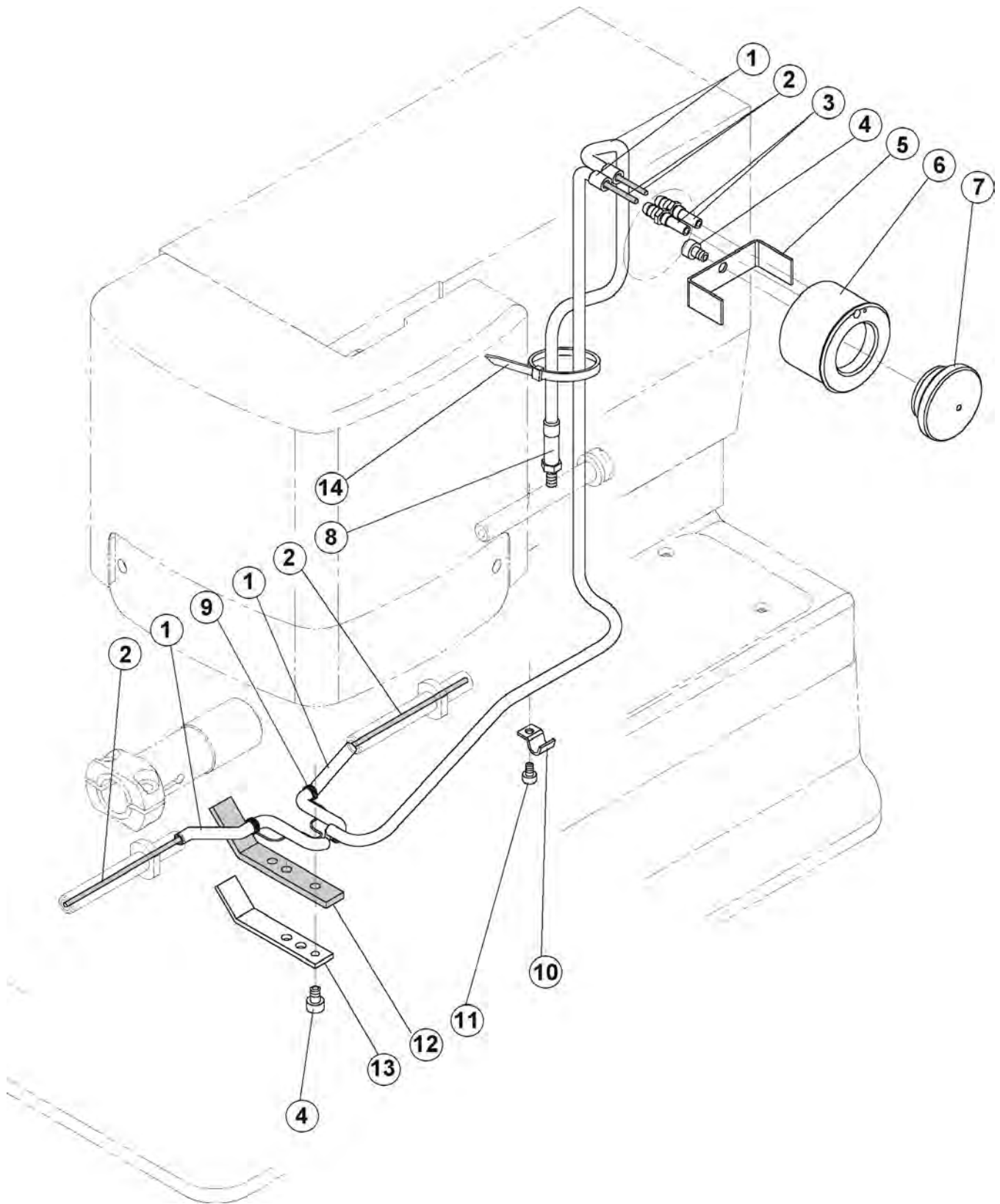



# TABLE

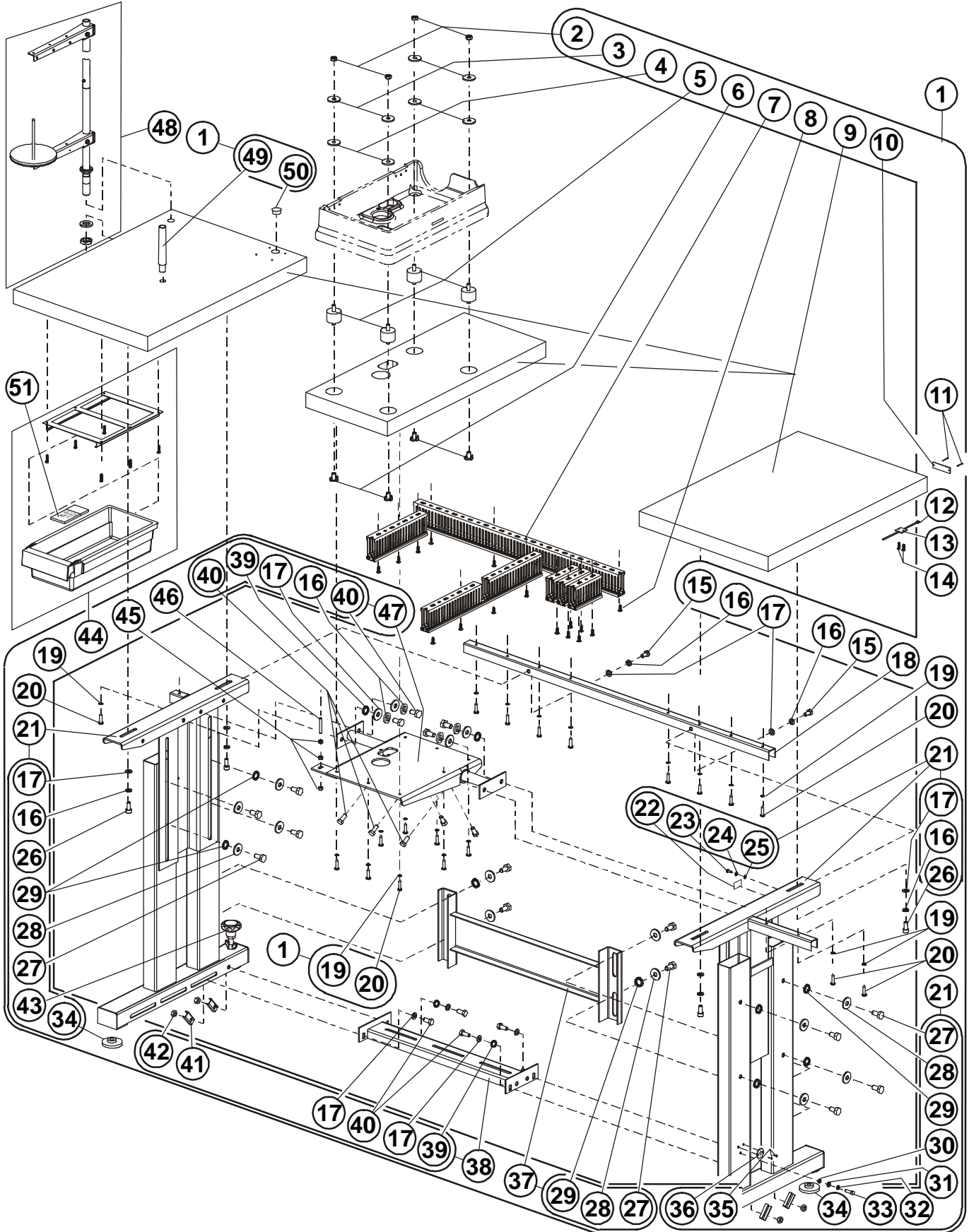

Released 05/2010

e-mail: [service@amfreece.cz](mailto:service@amfreece.cz); [parts@amfreece.cz](mailto:parts@amfreece.cz); website: [www.amfreece.com](http://www.amfreece.com)

Phone: +420 582 309 286; Fax: +420 582 360 606



## TABLE

DET	PART NUMBER	DESCRIPTION	QTY.
01	04.9024.0.002	Frame Assembly	1
02	08.6700.8.000	Nut M8	(4)
03	17.0019.0.441	Washer	(4)
04	17.0095.1.272	Rubber Washer ●●●	(4)
05	12.0008.6.801	Rubber Spring	(4)
06	08.6742.8.000	Nut M8 ●●●	(4)
07	24.0069.9.039	Latch For Kit ●●●	(1)
08	08.6676.3.020	Screw 3,5 x 20	(17)
09	04.9024.0.903	Table ●●●	(1)
10	04.1416.0.003	Label "No. xxxx"	(1)
11	12.1016.1.000	Nail	(2)
12	12.0008.3.023	Ty-wrap ●●●	(1)
13	12.0008.4.058	Clip	(1)
14	08.6652.3.016	Screw 3 x 16	(2)
15	08.6312.8.016	Screw M8 x 16	(2)
16	08.6802.8.000	Spring Washer	(4)+(2)+(4)
17	08.6852.8.000	Washer	(4)+(2)+(4)
18	04.9024.0.361	Reinforcement Crossbar	(1)
19	08.6852.5.000	Washer M5	(19)
20	08.6663.5.025	Screw 4,8 x 25	(19)
21	04.9024.0.002	Frame Assembly	(1)
22	12.0008.4.052	Label	((1))
23	08.6012.4.010	Screw M4 x 10	((1))
24	08.6852.4.000	Washer 4,3	((1))
25	08.6832.4.000	Lock Washer M4	((1))
26	08.6312.8.025	Screw M8 x 25	((4))
27	08.6312.0.020	Screw M10 x 20	((12))
28	08.6882.0.000	Washer M10	((12))
29	08.6832.0.000	Washer 10,5	((8+2+2))
30	08.6832.6.000	Lock Washer M6	((1))
31	08.6852.6.000	Washer 6,4	((1))
32	08.6802.6.000	Spring Washer	((1))
33	08.6312.6.020	Screw M6 x 20	((1))
34	12.0008.6.813	Rubber Washer ●●●	((3))
35	12.1016.0.000	Drive Screw	((2))
36	17.0081.6.225	Label	((1))
37	04.9000.0.225	Crossbar Rear	(1)
38	04.9000.0.125	Crossbar Down	(1)
39	08.6832.8.000	Lock Washer M8	((2)+(2))
40	08.6312.8.020	Screw	((4+9))
41	12.0008.6.964	Washer - U	((4))
42	08.6702.8.000	Nut M8	(4)
43	12.0008.6.965	Yielding Support	(1)
44	12.0008.6.901	Drawer Kit ●●●	(1)
45	08.6700.6.000	Nut M6	(3)
46	08.6700.6.000	Screw M6 x 40	(1)
47	04.9000.0.325	Crossbar Up Assembly	((1))
48	22.0219.0.000	Thread Stand	1
49	12.0008.6.900	Machine Rest Table Pin	(1)
50	12.0008.4.777	Plug	(1)
51	02.0750.2.109	Needle, Size 70	1

Released 05/2010

e-mail: [service@amfreece.cz](mailto:service@amfreece.cz); [parts@amfreece.cz](mailto:parts@amfreece.cz); website: [www.amfreece.com](http://www.amfreece.com)

Phone: +420 582 309 286; Fax: +420 582 360 606

3-33

# ELECTRICAL — I

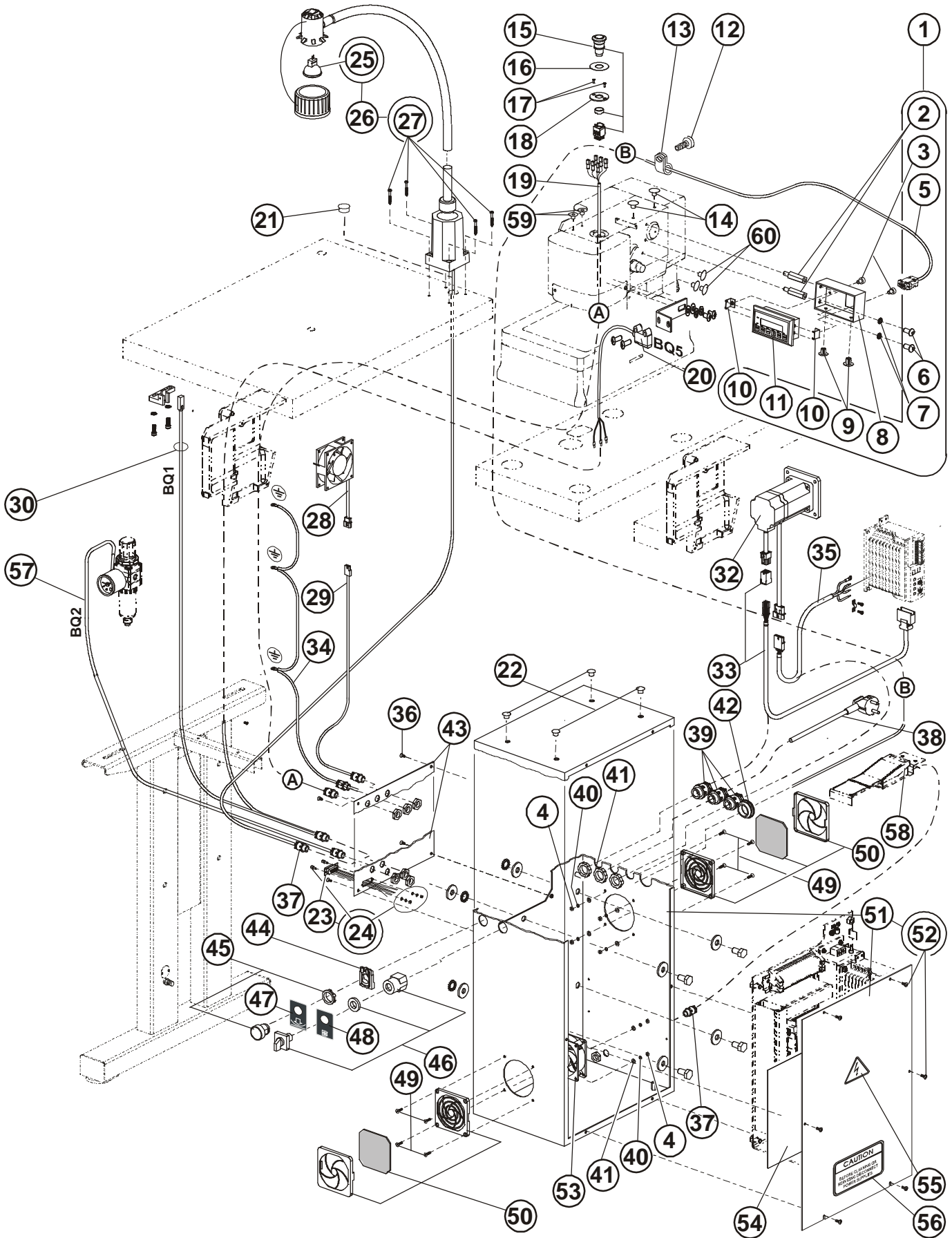

Released 10/2011

e-mail: [service@amfreece.cz](mailto:service@amfreece.cz); [parts@amfreece.cz](mailto:parts@amfreece.cz); website: [www.amfreece.com](http://www.amfreece.com)

Phone: +420 582 309 286; Fax: +420 582 360 606

## ELECTRICAL — I

DET	PART NUMBER	DESCRIPTION	QTY.
01	03.5524.0.024	Panel Kit	1
02	12.0008.4.565	Screw	(2)
03	08.6000.4.006	Screw	(2)
04	08.6702.4.000	Nut M4	8
05	06.2400.0.003	Cable Display	(1)
06	08.6200.6.012	Screw	(2)
07	08.6832.6.000	Serrated Washer	(2)
08	24.0146.0.000	Display Box	(1)
09	12.0008.4.571	Plug	(2)
10	24.0147.0.000	Panel Holder	(2)
11	24.8001.2.002	Display OMRON	(1)
12	See Page 3-2	Screw	—
13	See Page 3-2	Plastic Cable Fitting	—
14	12.0008.4.570	Plug	2
15	12.0008.4.563	Emergency Stop Button	1
16	12.8000.0.142	Label	1
17	08.6102.3.008	Screw	2
18	24.0148.0.000	Emergency Stop Cover	1
19	24.0069.9.023	Emergency Stop Cable	1
20	06.2400.0.401	Sensor BQ5	1
21	12.0008.4.777	Plug	1
22	12.0008.4.215	Plug	4
23	24.0069.9.034	Cable	1
24	12.0008.4.710	Screw Kit	1
25	12.0008.4.679	Bulb 12V/12W	(1)
26	12.0008.4.403	Halogen Lamp Kit 12 V Assembly	1
27	—	Screw	(4)
28	24.0059.9.069	Fan	1
29	24.0069.9.027	Fan Cable	1
30	06.2400.0.009	End of Cycle Sensor with Cable	1
31			
32	12.0010.4.177	Servomotor Assembly	1
33	12.0010.4.178	Encoder Cable	1
34	—	Cable	1
35	12.0010.4.179	Motor Power Cable	1
36	08.6100.4.010	Screw	4
37	12.0008.4.207	Bushing	7
38	12.0008.4.713	Cable	1
39	12.0008.4.231	Bushing	3
40	08.6802.4.000	Washer	4
41	08.6852.4.000	Washer	4
42	12.0008.4.366	Plug PG 29	1
43	24.3325.1.000	Connectors Plate	1
44	12.0008.4.863	Block	1
45	12.0008.4.861	Switch (Black)	1
46	12.0008.4.835	Switch ON — OFF	1
47	12.8000.0.041	Label (Clamp Up/Down)	1
48	12.8000.0.040	Label (Main Switch)	1
49	08.6100.4.014	Screw	1

Released 10/2011

e-mail: [service@amfreece.cz](mailto:service@amfreece.cz); [parts@amfreece.cz](mailto:parts@amfreece.cz); website: [www.amfreece.com](http://www.amfreece.com)

Phone: +420 582 309 286; Fax: +420 582 360 606



# ELECTRICAL — I

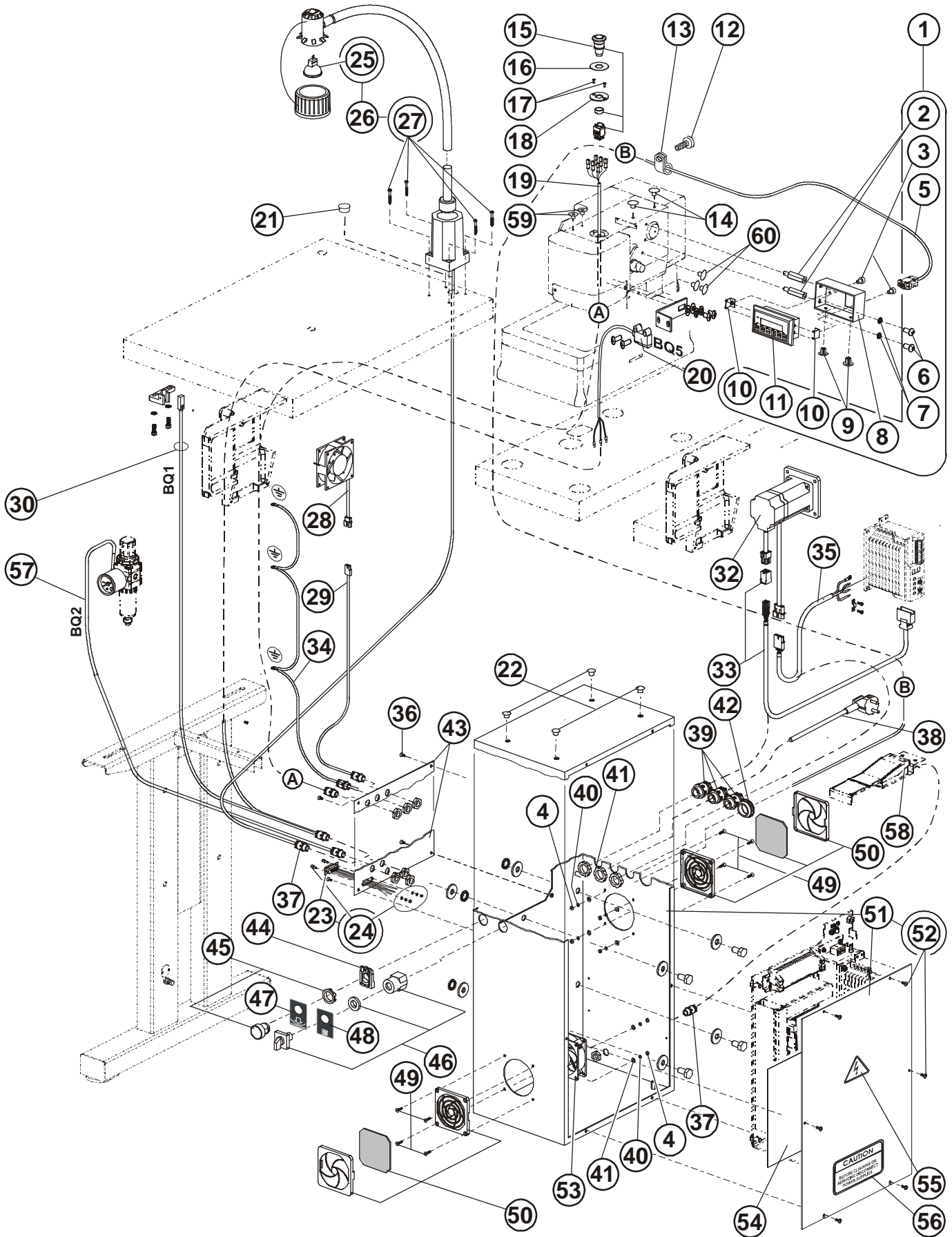

Released 10/2011

e-mail: [service@amfreece.cz](mailto:service@amfreece.cz); [parts@amfreece.cz](mailto:parts@amfreece.cz); website: [www.amfreece.com](http://www.amfreece.com)

Phone: +420 582 309 286; Fax: +420 582 360 606



# ELECTRICAL — II

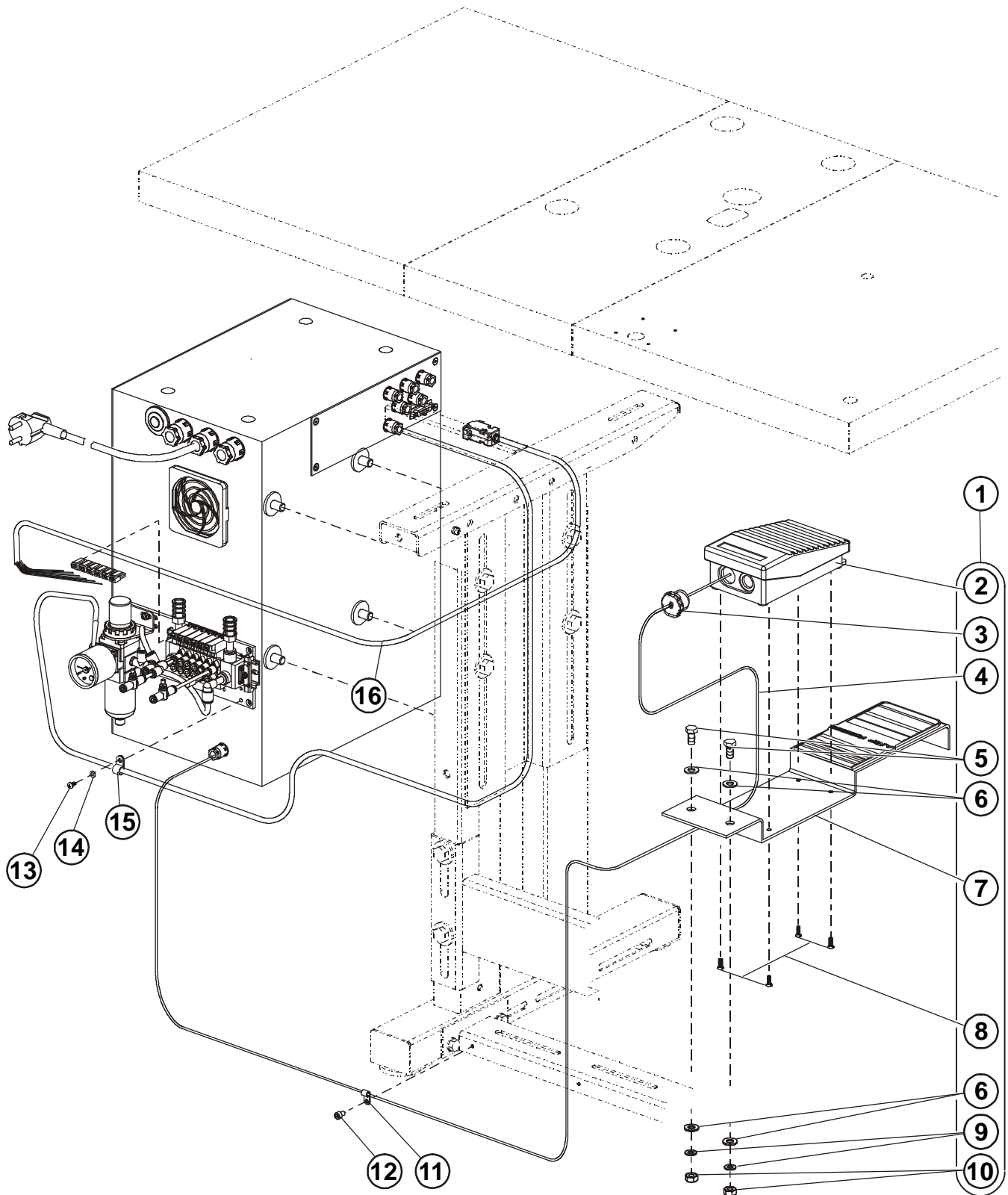

**ELECTRICAL — II**

DET	PART NUMBER	DESCRIPTION	QTY.
1	24.0069.9.038	Pedal Assembly	1
2	06.8800.0.001	Pedal ●●●	(1)
3	12.0008.4.296	Bushing ●●●	(1)
4	24.0069.9.003	Cable	(1)
5	08.6312.8.020	Screw M8x20	(2)
6	08.6852.8.000	Washer M8	(4)
7	24.0097.0.000	Holder Pedal	(1)
8	08.6100.4.012	Screw M4x12	(4)
9	08.6802.8.000	Spring Washer M8	(2)
10	08.6702.8.000	Nut M8	(2)
11	12.0008.4.279	Cord Clamp	1
12	08.6000.5.008	Screw M5x8	1
13	08.6683.4.007	Screw M4x7	1
14	08.6852.4.000	Washer M4	1
15	12.0008.4.280	Cord Clamp	1
16	12.0008.3.682	Cable Valve	1

Released 05/2010

e-mail: [service@amfreece.cz](mailto:service@amfreece.cz); [parts@amfreece.cz](mailto:parts@amfreece.cz); website: [www.amfreece.com](http://www.amfreece.com)

Phone: +420 582 309 286; Fax: +420 582 360 606

# ELECTRICAL — III

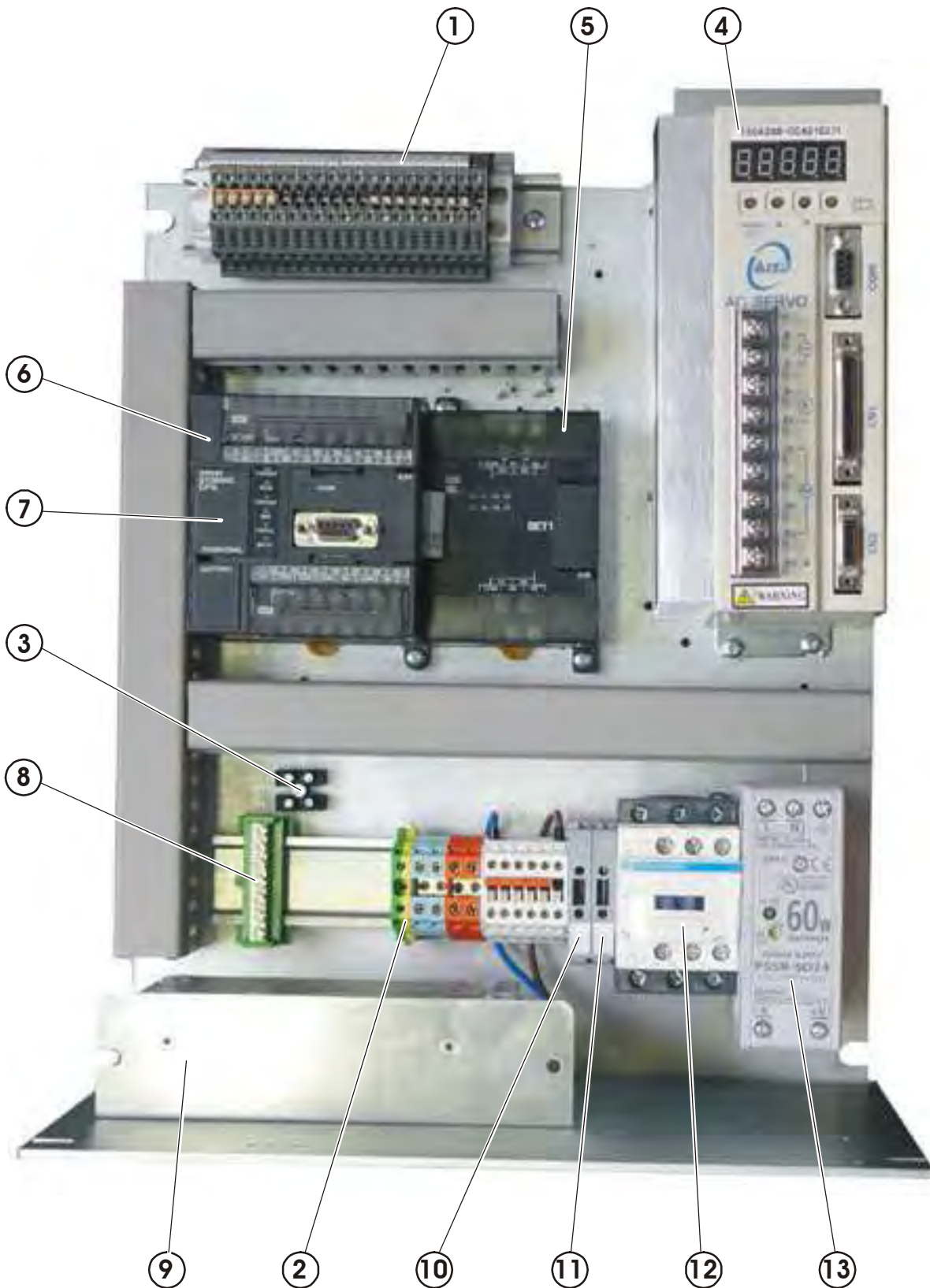







**PNEUMATICS — I**

DET	PART NUMBER	DESCRIPTION	QTY.
01	08.6032.4.012	Screw M4x12	2
02	19.0081.5.419	Plate	1
03	12.0008.3.659	Regulator Holder	1
04	12.0008.3.658	Regulator	1
05	08.6852.4.000	Washer M4	2
06	08.6702.4.000	Nut M4	2
07	12.0008.3.420	Connector	1
08	12.0008.3.484	Silencer	1
09	12.0008.3.479	Air Supply Block Assembly	1
10	12.8000.0.052	Labels Kit	1
11	12.0008.3.023	Ty-wrap	●●● 4
12	12.0008.4.058	Clip	●●● 4
13	12.0008.3.482	Pneumatic Valve	5
14	12.0008.3.480	Connector	1
15	12.0008.3.680	Pneumatic Valve	1
16	12.0008.3.477	Connector	26
17	12.0008.3.476	Rail Stopper	1
18	08.6683.4.007	Screw	3
19	12.0008.3.418	Pressure Gauge	1
20	08.6200.4.006	Screw M4x6	2
21	12.0008.3.605	Connector	1
22	12.0008.3.661	DIN Rail	1
23	12.0008.3.478	Rail Stopper	1
24	12.0008.3.606	Connector	2
25	12.0008.3.623	Connector	1
26	12.0008.3.430	Speed Controller	2
27	12.0008.3.437	Plug 6	1
28	12.0008.3.426	Plug 4	1
29	12.0008.3.413	Cylinder	1
30	12.0008.3.414	Connector	1
31	12.0008.3.433	Cylinder	1
32	12.0008.3.409	Connector	2
33	12.0008.3.411	Connector	6
34	12.0008.3.412	Cylinder	1
35	24.0050.0.000	Trimmer Cylinder	1
36	12.0008.3.683	Cylinder	1
37	24.3326.0.000	Air Tubing 6x1 BL J0I1 = 75 mm J0I2 = 125 mm J5A = 1500 mm  Air Tubing 4x0,75 BL J1A=J1B=J1B1=J2A=J2B=J3A=J3B=J4A=J4B=J6A=J1A1 = 1900 mm Air Tubing 12x2 BL J5 = 500 mm	●●● 1
	See Page 3-45		

Released 05/2010

e-mail: [service@amfreece.cz](mailto:service@amfreece.cz); [parts@amfreece.cz](mailto:parts@amfreece.cz); website: [www.amfreece.com](http://www.amfreece.com)

Phone: +420 582 309 286; Fax: +420 582 360 606

# PNEUMATICS — II

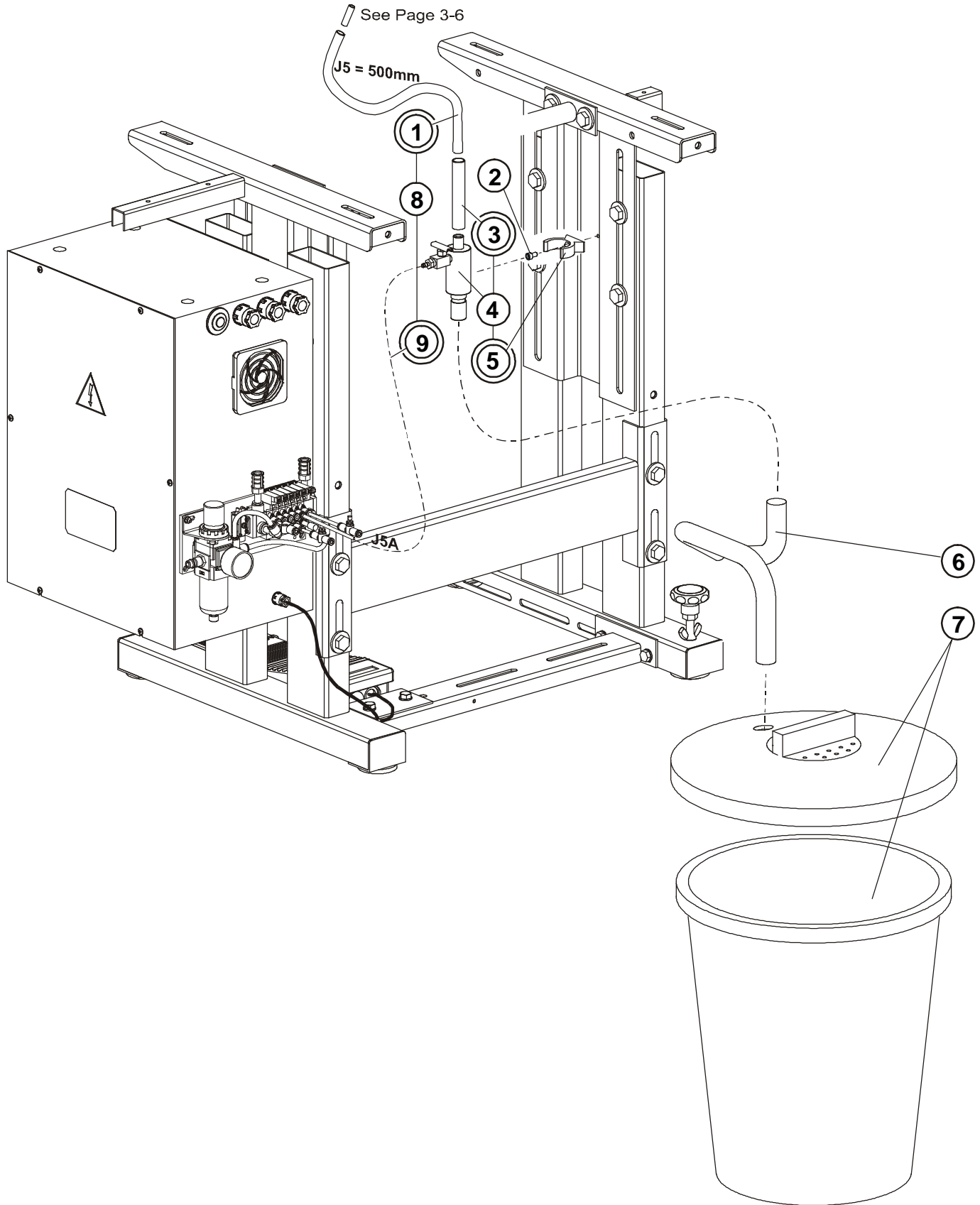

Released 05/2010

e-mail: [service@amfreece.cz](mailto:service@amfreece.cz); [parts@amfreece.cz](mailto:parts@amfreece.cz); website: [www.amfreece.com](http://www.amfreece.com)

Phone: +420 582 309 286; Fax: +420 582 360 606



# ACCESSORIES

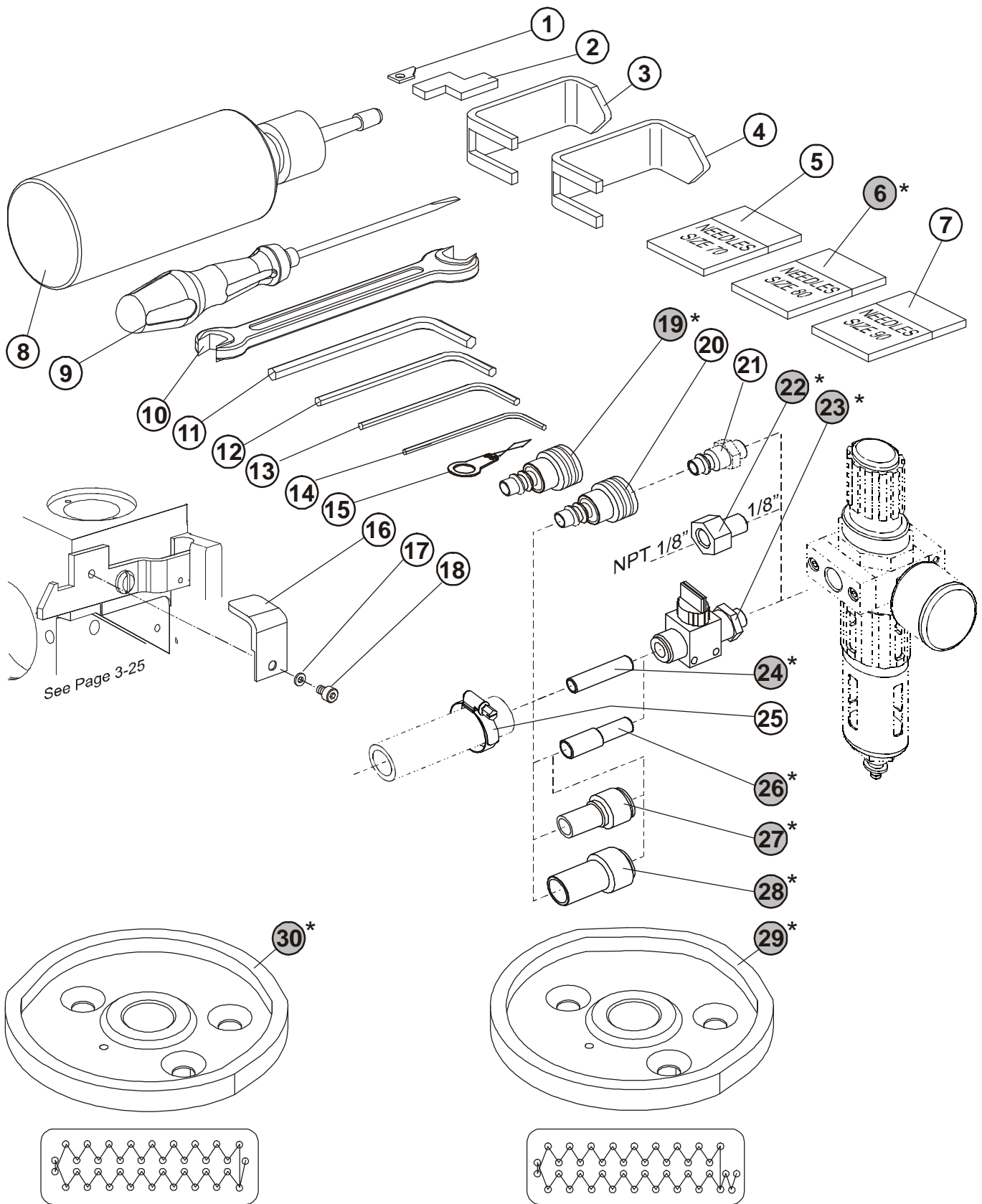

●\* — EXTRA PARTS

## ACCESSORIES

DET	PART NUMBER	DESCRIPTION	QTY.
01	20.0094.0.000	Trimmer Knife	1
02	22.0209.0.000	Looper Gauge	1
03	24.0030.0.000	Main Shaft Pulley Bracket	1
04	24.0024.0.000	Needle Bar Shaft Pulley Bracket	1
05	See Page 3-33	Needle, Size 70	—
06*	02.0750.2.100	Needle, Size 80	10
07	02.0750.2.110	Needles, Size 90	10
08	05.1322.0.000	Oiler <span style="float: right;">●●●</span>	1
09	12.0008.6.001	Screwdriver	1
10	12.0008.6.109	Wrench	1
11	12.0008.6.102	Allen Key Wrench 4	1
12	12.0008.6.101	Allen Key Wrench 3	1
13	12.0008.6.112	Allen Key Wrench 2-1/2	1
14	12.0008.6.100	Allen Key Wrench 2	1
15	12.0008.6.105	Needle Threader	1
16	22.0213.0.000	Bracket	1
17	08.6850.4.000	M4 Washer	1
18	08.6000.4.005	M4 x 5 Screw	1
19*	12.0008.3.607	Connector Dia 8	1
20	12.0008.3.608	Connector Dia 10	1
21	See page 3-43	Connector	—
22*	12.0008.3.081	Pneumatic Adapter (1/8" / NPT 1/8")	1
23*	12.0008.3.463	Handvalve	1
24*	12.0008.3.464	Connector	1
25	12.0008.3.251	Air Tubing Clamp	1
26*	12.0008.3.466	Connector	1
27*	12.0008.3.467	Connector	1
28*	12.0008.3.465	Connector	1
29*	24.3079.0.000	Main Cam - Type II	1
30*	24.3077.0.000	Main Cam - Type I	1

\* — Extra Parts

Released 05/2010

e-mail: [service@amfreece.cz](mailto:service@amfreece.cz); [parts@amfreece.cz](mailto:parts@amfreece.cz); website: [www.amfreece.com](http://www.amfreece.com)

Phone: +420 582 309 286; Fax: +420 582 360 606





# INDEX

PART NUMBER	PAGE	DET	QTY	PART NUMBER	PAGE	DET	QTY	PART NUMBER	PAGE	DET	QTY
<b>00.2751.3.602</b>				<b>07.6045.0.009</b>				08.6000.4.006	3-31	04	2
00.2751.3.602	3-35	56	1	07.6045.0.009	3-11	19	2	08.6000.4.006	3-35	03	(2)
<b>01.1382.0.000</b>				07.6045.0.034	3-11	30	1	08.6000.4.010	3-9	06	2
01.1382.0.000	3-15	06	1	07.6045.0.037	3-11	16	2	08.6000.4.010	3-21	07	1
01.1397.0.000	3-15	11	4	07.6045.0.037	3-25	05	1	08.6000.4.012	3-7	16	1
01.2084.0.000	3-5	30	1	07.6045.0.042	3-7	05	1	08.6000.4.014	3-11	45	2
01.2193.0.000	3-3	02	1	07.6045.0.042	3-21	04	1	08.6000.4.014	3-15	25	2
01.2376.0.000	3-5	26	4	07.6045.0.053	3-25	10	1	08.6000.4.014	3-19	08	2
01.2386.0.000	3-7	30	1	07.6045.0.054	3-27	07	1	08.6000.4.016	3-7	25	1
01.2563.0.000	3-5	07	2	<b>07.6321.0.001</b>				08.6000.4.016	3-9	05	4
01.4980.0.000	3-25	43	1	07.6321.0.001	3-23	11	1	08.6000.4.016	3-21	10	6
01.5602.0.000	3-7	10	1	07.6321.0.025	3-11	50	2	08.6000.4.025	3-11	32	2
01.6551.0.000	3-3	07	1	07.6321.0.025	3-19	16	2	08.6000.4.070	3-29	07	4
01.6551.0.000	3-21	17	1	07.6321.0.029	3-19	13	(2)	<b>08.6000.5.008</b>			
01.7447.1.000	3-3	05	1	07.6321.0.029	3-19	13	(2)	08.6000.5.008	3-39	12	1
01.7447.1.000	3-21	15	1	07.6321.0.030	3-11	61	(1).	08.6000.5.008	3-45	02	1
01.7804.0.000	3-3	18	1	<b>07.6440.0.018</b>				08.6000.5.012	3-5	16	1
01.7805.0.000	3-3	23	1	07.6440.0.018	3-11	41	2	08.6000.5.012	3-7	34	1
01.7805.0.000	3-27	34	2	07.6440.0.028	3-11	23	2	08.6000.5.016	3-3	37	1
01.7806.0.000	3-25	29	2	07.6440.0.028	3-19	18	2	08.6000.5.016	3-21	03	1
01.7809.0.000	3-3	17	1	07.6440.0.033	3-11	08	2	08.6000.5.016	3-25	12	8
<b>02.0750.2.100</b>				07.6440.0.036	3-15	21	3	08.6000.5.016	3-27	19	3
02.0750.2.100	3-47	06*	10	07.6440.0.037	3-23	04	2	08.6000.5.020	3-11	15	2
02.0750.2.109	3-3	32	1	07.6440.0.040	3-9	10	1	08.6000.5.022	3-5	14	4
02.0750.2.109	3-33	51	1	07.6440.0.041	3-11	11	1	<b>08.6000.6.010</b>			
02.0750.2.110	3-47	07	10	07.6440.0.045	3-23	27	1	08.6000.6.010	3-5	01	2
03.5524.0.024	3-35	01	1	07.6440.0.050	3-11	18	1	08.6000.6.016	3-3	22	2
<b>04.1416.0.003</b>				07.6440.0.051	3-25	03	1	08.6000.6.016	3-27	18	2
04.1416.0.003	3-33	10	(1)	<b>08.6000.3.006</b>				08.6000.6.016	3-3	31	1
04.9000.0.125	3-33	38	(1)	08.6000.3.006	3-21	29	1	08.6000.6.025	3-3	31	1
04.9000.0.225	3-33	37	(1)	08.6000.3.006	3-27	10	1	08.6000.6.025	3-19	01	1
04.9000.0.325	3-33	47	((1))	08.6000.3.006	3-31	11	1	08.6000.6.025	3-25	42	2
04.9024.0.002	3-33	01	1	08.6000.3.008	3-7	18	3	08.6000.6.030	3-3	15	(1)
04.9024.0.002	3-33	21	(1)	08.6000.3.010	3-7	18	3	08.6000.8.025	3-25	35	2
04.9024.0.361	3-33	18	(1)	08.6000.3.010	3-11	38	1	08.6000.8.040	3-25	34	2
04.9024.0.500	3-35	51	1	08.6000.3.010	3-15	17	1	08.6012.4.010	3-17	11	1
04.9024.0.903	3-33	09	(1)	08.6000.3.010	3-19	06	1	08.6012.4.010	3-33	23	((1))
<b>05.1322.0.000</b>				08.6000.3.012	3-7	12	1	08.6032.4.010	3-35	52	(6)
05.1322.0.000	3-47	08	1	08.6000.3.016	3-29	09	4	08.6032.4.012	3-43	01	2
05.1394.0.000	3-27	03	1	08.6000.3.040	3-7	41	2	<b>08.6100.3.008</b>			
<b>06.2400.0.003</b>				08.6000.3.040	3-29	08	1	08.6100.3.008	3-19	05	2
06.2400.0.003	3-35	05	(1)	<b>08.6000.4.005</b>				08.6100.3.008	3-27	26	1
06.2400.0.009	3-35	30	1	08.6000.4.005	3-9	09	4	08.6100.3.016	3-25	33	1
06.2400.0.401	3-35	20	1	08.6000.4.005	3-11	58	2	08.6100.3.030	3-11	01	2
				08.6000.4.005	3-47	18	1	08.6100.4.006	3-5	32	4
				08.6000.4.006	3-5	23	2	08.6100.4.006	3-9	01	3
				08.6000.4.006	3-27	25	1	08.6100.4.006	3-27	04	2
				08.6000.4.006	3-29	15	2	08.6100.4.010	3-35	36	4

Revised 10/2011

e-mail: service@amfreece.cz; parts@amfreece.cz; website: www.amfreece.com

Phone: +420 582 309 286; Fax: +420 582 360 606

# INDEX

PART NUMBER	PAGE	DET	QTY	PART NUMBER	PAGE	DET	QTY	PART NUMBER	PAGE	DET	QTY
08.6100.4.012	3-23	15	1	<b>08.6400.5.005</b>				08.6800.4.000	3-21	19	2
08.6100.4.012	3-39	08	(4)	08.6400.5.005	3-3	04	1	08.6800.5.000	3-7	33	1
08.6100.4.014	3-35	49	1	08.6400.5.005	3-11	33	1	08.6802.4.000	3-35	40	4
<b>08.6100.5.010</b>				08.6400.5.005	3-25	23	2	08.6802.6.000	3-33	32	((1))
08.6100.5.010	3-23	09	1	08.6400.5.005	3-27	08	2	08.6802.8.000	3-33	16	4)+(2)+((4)
08.6100.5.012	3-5	33	2	08.6400.5.008	3-5	22	1	08.6802.8.000	3-39	09	(2)
08.6100.5.012	3-17	02	5	08.6400.5.008	3-25	24	2	08.6832.0.000	3-33	29	((8+2+2))
08.6100.5.016	3-29	01	7	08.6400.5.010	3-25	09	1	08.6832.4.000	3-17	12	1
08.6100.5.020	3-15	04	2	08.6400.5.010	3-27	09	2	08.6832.4.000	3-33	25	((1))
08.6100.5.020	3-17	08	1	08.6400.5.305	3-11	13	4	08.6832.6.000	3-33	30	((1))
08.6100.5.020	3-25	31	3	08.6400.5.305	3-27	21	6	08.6832.6.000	3-35	07	(2)
08.6100.6.035	3-27	13	1	<b>08.6652.3.016</b>				08.6832.8.000	3-33	39	(2)+(2)
08.6102.3.008	3-35	17	2	08.6652.3.016	3-33	14	(2)	<b>08.6850.3.000</b>			
08.6117.7.004	3-7	06	2	08.6663.5.025	3-33	20	(19)	08.6850.3.000	3-7	35	5
08.6120.3.008	3-27	01	7	08.6676.3.020	3-33	08	(17)	08.6850.3.000	3-21	27	1
<b>08.6200.3.012</b>				08.6683.4.007	3-39	13	1	08.6850.3.000	3-25	20	2
08.6200.3.012	3-25	17	2	08.6683.4.007	3-43	17	3	08.6850.4.000	3-7	01	1
08.6200.3.012	3-25	22	2	08.6683.4.007	3-43	18	3	08.6850.4.000	3-7	24	1
08.6200.4.006	3-5	05	1	<b>08.6700.3.000</b>				08.6850.4.000	3-21	18	2
08.6200.4.006	3-43	20	2	08.6700.3.000	3-7	19	2	08.6850.4.000	3-27	24	1
08.6200.4.008	3-29	17	2	08.6700.3.000	3-25	37	1	08.6850.4.000	3-47	17	1
08.6200.4.016	3-21	22	2	08.6700.4.000	3-5	17	1	08.6850.5.000	3-23	20	1
08.6200.5.008	3-25	15	1	08.6700.4.000	3-7	03	1	08.6850.5.000	3-25	14	7
08.6200.5.012	3-17	03	5	08.6700.5.000	3-17	10	3	08.6850.5.000	3-27	31	2
08.6200.5.020	3-17	04	2	08.6700.5.000	3-19	24	2	08.6850.5.000	3-29	04	4
08.6200.6.012	3-35	06	(2)	08.6700.5.000	3-23	19	1	08.6850.6.000	3-25	41	2
08.6215.4.006	3-35	59	2	08.6700.5.000	3-25	32	3	08.6850.8.000	3-11	56	1
<b>08.6312.0.020</b>				08.6700.6.000	3-33	45	(3)	08.6850.8.000	3-15	32	1
08.6312.0.020	3-33	27	((12))	08.6700.6.000	3-33	46	(1)	<b>08.6852.4.000</b>			
08.6312.6.020	3-33	33	((1))	08.6700.8.000	3-11	57	1	08.6852.4.000	3-33	24	((1))
08.6312.8.016	3-33	15	(2)	08.6700.8.000	3-15	33	1	08.6852.4.000	3-35	41	4
08.6312.8.020	3-33	40	((4+9))	08.6700.8.000	3-33	02	(4)	08.6852.4.000	3-39	14	1
08.6312.8.020	3-39	05	(2)	08.6702.4.000	3-35	04	8	08.6852.4.000	3-43	05	2
08.6312.8.025	3-33	26	((4))	08.6702.4.000	3-43	06	2	08.6852.4.000	3-43	05	2
<b>08.6400.3.004</b>				08.6702.4.000	3-43	06	2	08.6852.5.000	3-33	19	(19)
08.6400.3.004	3-27	29	1	08.6702.8.000	3-33	42	(4)	08.6852.6.000	3-33	31	((1))
08.6400.3.005	3-3	12	4	08.6702.8.000	3-39	10	(2)	08.6852.8.000	3-33	17	4)+(2)+((4)
08.6400.4.004	3-3	21	2 (2)	08.6710.5.000	3-11	52	2	08.6852.8.000	3-39	06	(4)
08.6400.4.004	3-5	09	2	08.6710.5.000	3-15	23	2	08.6882.0.000	3-33	28	((12))
08.6400.4.004	3-15	01	2	08.6710.6.000	3-21	01	1	08.6887.5.000	3-7	21	1
08.6400.4.004	3-19	27	1	08.6733.3.000	3-11	24	2	08.6887.5.000	3-9	12	1
08.6400.4.004	3-21	26	1	08.6742.8.000	3-33	06	(4)	08-6032-4-012	3-43	01	2
08.6400.4.005	3-9	16	1	<b>08.6800.3.000</b>				<b>12.0008.3.023</b>			
08.6400.4.005	3-11	28	6	08.6800.3.000	3-25	21	2	12.0008.3.023	3-25	27	1
08.6400.4.005	3-19	20	1	08.6800.4.000	3-5	04	2	12.0008.3.023	3-31	14	1
08.6400.4.012	3-5	18	1	08.6800.4.000	3-11	43	2	12.0008.3.023	3-33	12	(1)
				08.6800.4.000	3-15	26	2	12.0008.3.023	3-43	11	4

Revised 10/2011

e-mail: service@amfreece.cz; parts@amfreece.cz; website: www.amfreece.com

Phone: +420 582 309 286; Fax: +420 582 360 606

# INDEX

PART NUMBER	PAGE	DET	QTY	PART NUMBER	PAGE	DET	QTY	PART NUMBER	PAGE	DET	QTY
12.0008.3.023	3-43	11	4	12.0008.3.610	3-43	15	1	12.0008.4.713	3-35	38	1
12.0008.3.081	3-47	22*	1	12.0008.3.623	3-43	23	1	12.0008.4.777	3-33	50	(1)
12.0008.3.251	3-47	25	1	12.0008.3.623	3-43	25	1	12.0008.4.777	3-35	21	1
12.0008.3.265	3-45	04	1	12.0008.3.658	3-43	04	1	12.0008.4.835	3-35	46	1
				12.0008.3.658	3-43	04	1	12.0008.4.861	3-35	45	1
				12.0008.3.659	3-43	03	1	12.0008.4.863	3-35	44	1
<b>12.0008.3.409</b>				12.0008.3.659	3-43	03	1				
12.0008.3.409	3-43	28	2	12.0008.3.661	3-43	20	1	<b>12.0008.6.001</b>			
12.0008.3.409	3-43	32	2	12.0008.3.661	3-43	22	1	12.0008.6.001	3-47	09	1
12.0008.3.411	3-43	29	6	12.0008.3.661	3-43	22	1	12.0008.6.100	3-47	14	1
12.0008.3.411	3-43	33	6	12.0008.3.680	3-43	15	1	12.0008.6.101	3-47	12	1
12.0008.3.412	3-43	30	1	12.0008.3.681	3-45	01	(1)	12.0008.6.102	3-47	11	1
12.0008.3.412	3-43	34	1	12.0008.3.682	3-39	16	1	12.0008.6.105	3-47	15	1
12.0008.3.413	3-43	25	1	12.0008.3.683	3-43	32	1	12.0008.6.109	3-47	10	1
12.0008.3.413	3-43	29	1	12.0008.3.683	3-43	36	1	12.0008.6.112	3-47	13	1
12.0008.3.414	3-43	26	1	12.0008.3.830	3-43	16	1	12.0008.6.251	3-7	27	1
12.0008.3.414	3-43	30	1	12.0008.3.831	3-43	21	1	12.0008.6.800	3-19	23	1
12.0008.3.415	3-45	09	(1)	12.0008.3.892	3-43	14	1	12.0008.6.801	3-33	05	(4)
12.0008.3.418	3-43	18	1					12.0008.6.813	3-33	34	((3))
12.0008.3.418	3-43	19	1	<b>12.0008.4.050</b>				12.0008.6.900	3-33	49	(1)
12.0008.3.420	3-43	07	1	12.0008.4.050	3-41	08	1	12.0008.6.901	3-33	44	(1)
12.0008.3.420	3-43	07	1	12.0008.4.052	3-17	13	1	12.0008.6.964	3-33	41	((4))
12.0008.3.426	3-43	28	1	12.0008.4.052	3-33	22	((1))	12.0008.6.965	3-33	43	(1)
12.0008.3.430	3-43	24	2	12.0008.4.058	3-33	13	(1)				
12.0008.3.430	3-43	26	2	12.0008.4.058	3-43	12	4	<b>12.0010.4.013</b>			
12.0008.3.433	3-43	27	1	12.0008.4.058	3-43	12	4	12.0010.4.013	3-3	38	1
12.0008.3.433	3-43	31	1	12.0008.4.100	3-17	14	1	12.0010.4.067	3-41	07	1
12.0008.3.437	3-43	27	1	12.0008.4.155	3-35	55	1	12.0010.4.071	3-41	05	
12.0008.3.463	3-47	23*	1	12.0008.4.197	3-17	09	1	12.0010.4.071	3-41	13	1
12.0008.3.464	3-47	24*	1	12.0008.4.204	3-39	02	(1)	12.0010.4.078	3-41	09	1
12.0008.3.465	3-47	28*	1	12.0008.4.207	3-35	37	7	12.0010.4.177	3-35	32	1
12.0008.3.466	3-47	26*	1	12.0008.4.215	3-35	22	4	12.0010.4.178	3-35	33	1
12.0008.3.467	3-47	27*	1	12.0008.4.231	3-35	39	3	12.0010.4.179	3-35	35	1
12.0008.3.476	3-43	17	1	12.0008.4.279	3-39	11	1	12.1010.2.003	3-25	06	1
12.0008.3.477	3-43	16	26	12.0008.4.280	3-17	18	1	12.1011.0.001	3-25	36	1
12.0008.3.478	3-43	23	1	12.0008.4.280	3-39	15	1	12.1016.0.000	3-33	35	((2))
12.0008.3.479	3-43	09	1	12.0008.4.296	3-39	03	(1)	12.1016.1.000	3-33	11	(2)
12.0008.3.479	3-43	09	1	12.0008.4.33	3-41	12	1	12.1045.2.001	3-3	29	1
12.0008.3.480	3-43	14	1	12.0008.4.366	3-35	42	1	12.1045.2.001	3-27	33	1
12.0008.3.482	3-43	13	5	12.0008.4.403	3-35	26	1	12.1045.3.001	3-7	31	1
12.0008.3.482	3-43	13	5	12.0008.4.472	3-35	50	2				
12.0008.3.484	3-43	08	1	12.0008.4.563	3-35	15	1	<b>12.2010.1.002</b>			
12.0008.3.484	3-43	08	1	12.0008.4.565	3-35	02	(2)	12.2010.1.002	3-15	14	2
				12.0008.4.570	3-35	14	2	12.2050.0.003	3-3	20	1
				12.0008.4.571	3-35	09	(2)	12.2050.0.005	3-27	17	1
<b>12.0008.3.605</b>				12.0008.4.598	3-25	38	1	12.4030.0.002	3-27	14	1
12.0008.3.605	3-43	19	1	12.0008.4.604	3-5	27	(1)	12.5050.2.009	3-25	25	1
12.0008.3.605	3-43	21	1	12.0008.4.664	3-41	11	1	12.8000.0.040	3-35	48	1
12.0008.3.606	3-43	22	2	12.0008.4.665	3-41	10	1	12.8000.0.041	3-35	47	1
12.0008.3.606	3-43	24	2	12.0008.4.679	3-35	25	(1)	12.8000.0.050	3-35	54	1
12.0008.3.607	3-47	19*	1	12.0008.4.710	3-35	24	1				
12.0008.3.608	3-47	20	1								

Revised 10/2011

e-mail: [service@amfreece.cz](mailto:service@amfreece.cz); [parts@amfreece.cz](mailto:parts@amfreece.cz); website: [www.amfreece.com](http://www.amfreece.com)

Phone: +420 582 309 286; Fax: +420 582 360 606

# INDEX

PART NUMBER	PAGE	DET	QTY	PART NUMBER	PAGE	DET	QTY	PART NUMBER	PAGE	DET	QTY
12.8000.0.052	3-43	10	1	22.0032.0.000	3-11	49	2	<b>22.0208.0.000</b>			
12.8000.0.052	3-43	10	1	22.0033.0.000	3-19	25	1	22.0208.0.000	3-11	26	1
12.8000.0.142	3-35	16	1	22.0046.0.000	3-21	16	1	22.0209.0.000	3-47	02	1
				22.0049.0.000	3-11	31	1	22.0213.0.000	3-47	16	1
<b>17.0013.5.067</b>				22.0054.0.000	3-25	16	1	22.0214.0.000	3-19	10	1
17.0013.5.067	3-7	40	2	22.0057.0.000	3-29	14	1	22.0219.0.000	3-33	48	1
17.0019.0.441	3-33	03	(4)	22.0058.0.000	3-25	02	1	22.0228.0.000	3-11	12	1
17.0019.0.517	3-11	37	1	22.0061.0.000	3-11	07	1	22.0229.0.000	3-31	03	2
17.0019.2.057	3-11	25	1	22.0062.0.000	3-25	04	1	22.0230.0.000	3-3	08	2
17.0019.5.040	3-7	39	2	22.0063.0.000	3-19	04	1	22.0232.0.000	3-11	53	1
17.0027.1.799	3-31	09	1	22.0064.0.000	3-15	16	1	22.0232.0.000	3-15	24	1
17.0081.6.225	3-33	36	((1))	22.0064.0.000	3-19	14	2	22.0233.0.000	3-15	30	1
17.0082.6.000	3-31	10	1	22.0069.0.000	3-19	21	1	22.0239.0.000	3-3	09	2
17.0082.8.082	3-25	07	1	22.0091.0.000	3-21	24	1				
17.0094.5.310	3-31	12	1	22.0097.0.000	3-23	13	1	<b>22.0300.0.000</b>			
17.0095.1.272	3-33	04	(4)					22.0300.0.000	3-27	37	1
17.0095.1.329	3-31	07	1	<b>22.0100.0.000</b>				22.0305.0.000	3-11	35	1
				22.0100.0.000	3-11	34	4	22.0309.0.000	3-11	20	(1)
<b>19.0081.5.419</b>				22.0100.0.000	3-15	20	3	22.0309.0.050	3-11	59	1
19.0081.5.419	3-43	02	1	22.0100.0.000	3-19	11	4	22.0312.0.000	3-11	06	1
19.0081.5.419	3-43	02	1	22.0104.0.000	3-31	06	1	22.0313.0.000	3-11	17	(1)
				22.0105.0.000	3-15	29	1	22.0315.0.000	3-11	22	1
<b>20.0092.0.004</b>				22.0106.0.000	3-23	25	2	22.0320.0.000	3-11	36	1
20.0092.0.004	3-7	29	1	22.0107.0.000	3-31	13	1	22.0325.0.000	3-11	10	1
20.0094.0.000	3-15	07	1	22.0108.0.000	3-31	08	1	22.0336.0.000	3-11	44	1
20.0094.0.000	3-47	01	1	22.0110.0.000	3-11	54	1	22.0353.0.000	3-11	48	3
20.0111.0.000	3-15	08	1	22.0110.0.000	3-19	09	1	22.0354.0.000	3-11	04	1
20.0112.0.000	3-15	10	1	22.0114.0.000	3-11	02	1	22.0370.0.000	3-11	46	1
<b>22.0006.0.000</b>				<b>22.0120.0.000</b>				<b>22.0400.0.000</b>			
22.0006.0.000	3-27	22	1	22.0120.0.000	3-31	05	1	22.0400.0.000	3-9	17	1
22.0008.0.000	3-19	02	1	22.0121.0.000	3-11	03	1	22.0405.0.000	3-9	14	1
22.0009.0.000	3-19	12	(1)	22.0137.0.000	3-23	10	2	22.0408.1.000	3-27	05	1
22.0009.0.050	3-19	28	1	22.0153.0.000	3-27	35	2	22.0520.0.000	3-3	06	1
22.0020.0.000	3-19	22	1	22.0159.0.000	3-5	20	1	22.0525.0.000	3-3	16	(1)
22.0021.0.000	3-11	47	1	22.0161.0.000	3-21	23	1	22.0525.0.050	3-3	24	1
22.0021.0.000	3-15	27	1	22.0173.0.000	3-5	11	2	22.0530.0.000	3-3	10	1
22.0022.0.000	3-11	55	1	22.0175.0.000	3-3	27	1	22.0535.0.100	3-3	30	1
22.0022.0.000	3-15	31	1	22.0177.0.000	3-3	35	2	22.0540.0.000	3-3	14	1
22.0023.0.000	3-15	28	1	22.0178.0.000	3-3	34	1	22.0541.0.000	3-3	13	1
22.0024.0.000	3-15	22	1	22.0179.0.000	3-5	10	1	22.0542.0.000	3-3	11	1
22.0026.0.000	3-11	40	1	22.0182.0.000	3-7	23	1	22.0545.0.000	3-3	25	1
22.0027.0.000	3-19	19	1	22.0182.0.000	3-23	12	2	22.0545.0.000	3-27	38	1
22.0028.0.000	3-19	17	2	22.0183.0.000	3-11	39	1				
22.0029.0.000	3-19	15	2	22.0183.0.000	3-15	18	1	<b>22.1010.0.000</b>			
				22.0183.0.000	3-19	07	1	22.1010.0.000	3-17	05	2
<b>22.0030.0.000</b>				22.0184.0.000	3-11	21	3	22.1415.0.050	3-21	11	1
22.0030.0.000	3-19	26	1	22.0186.0.000	3-11	27	1	22.1422.0.000	3-25	13	1
22.0031.0.000	3-11	51	2	22.0195.0.000	3-3	01	1	22.1436.0.000	3-21	14	2
22.0031.0.000	3-15	15	2								

Revised 10/2011

e-mail: [service@amfreece.cz](mailto:service@amfreece.cz); [parts@amfreece.cz](mailto:parts@amfreece.cz); website: [www.amfreece.com](http://www.amfreece.com)

Phone: +420 582 309 286; Fax: +420 582 360 606

# INDEX

PART NUMBER	PAGE	DET	QTY	PART NUMBER	PAGE	DET	QTY	PART NUMBER	PAGE	DET	QTY
<b>22.2425.0.050</b>				24.0016.0.000	39	39	1	24.0147.0.000	3-35	10	(2)
22.2425.0.050	3-15	19	1	24.0018.0.000	11	11	1	24.0148.0.000	3-35	18	1
22.2442.0.000	3-15	02	2	24.0019.0.000	16	16	1	24.0154.0.000	3-29	16	1
22.2607.0.000	3-23	01	1	24.0020.0.000	30	30	1	24.0158.1.000	3-5	21	1
22.2610.0.000	3-23	14	1	24.0024.0.000	04	04	1	24.0351.0.000	3-11	09	1
22.2626.0.000	3-23	03	1	24.0027.0.000	28	28	1	24.0500.0.000	3-3	19	1
22.2627.0.000	3-23	02	2	24.0030.0.000	03	03	1	24.0510.0.000	3-3	03	1
22.2630.0.000	3-23	21	1	24.0035.1.000	15	15	1				
22.2631.0.000	3-23	24	1	24.0036.1.000	12	12	1	<b>24.1000.0.000</b>			
22.2633.0.000	3-23	23	1	24.0037.0.000	02	02	1	24.1000.0.000	3-27	15	1
22.2635.0.000	3-23	16	1	24.0038.0.000	06	06	1	24.1430.1.000	3-21	20	1
22.2637.0.000	3-23	22	1	24.0039.1.000	13	13	1	24.2035.0.000	3-11	29	1
22.2638.0.000	3-23	17	1	24.0048.0.000	26	26	1	24.2400.0.000	3-27	32	1
22.2639.0.000	3-23	18	1	24.0049.0.000	14	14	2	24.3026.0.000	3-5	19	1
22.2640.0.050	3-23	26	1					24.3070.0.000	3-23	06	1
22.2652.0.000	3-9	08	1	<b>24.0050.0.000</b>				24.3076.0.000	3-23	05	1
22.2653.0.000	3-9	07	1	24.0050.0.000	31	31	1	24.3077.0.000	3-47	30*	1
22.2655.0.000	3-9	02	1	24.0050.0.000	35	35	1	24.3079.0.000	3-47	29*	1
22.2656.0.000	3-9	03	1	24.0051.0.066	12	12	1	24.3080.0.000	3-23	08	1
22.2657.0.000	3-9	04	1	24.0055.0.000	03	03	1				
22.2664.0.000	3-9	18	1	24.0059.9.017	53	53	1	<b>24.3300.0.000</b>			
22.2665.0.000	3-9	15	1	24.0059.9.069	28	28	1	24.3300.0.000	3-27	02	1
				24.0061.0.000	28	28	1	24.3301.0.000	3-5	25	1
<b>22.3003.0.000</b>				24.0062.0.000	21	21	1	24.3302.0.000	3-5	28	1
22.3003.0.000	3-23	28	1	24.0063.0.000	25	25	1	24.3303.0.000	3-5	24	1
22.3028.0.000	3-5	29	1	24.0066.0.000	13	13	2	24.3304.0.000	3-5	06	1
22.3069.0.000	3-23	07	1	24.0067.0.000	03	03	1	24.3305.0.000	3-5	02	1
22.3251.0.000	3-5	08	1	24.0068.0.000	02	02	1	24.3306.0.000	3-5	03	1
22.6002.0.000	3-25	30	1	24.0069.9.003	4	04	(1)	24.3307.0.000	3-9	11	1
22.8400.0.000	3-27	36	1	24.0069.9.023	19	19	1	24.3308.0.000	3-9	13	1
				24.0069.9.027	29	29	1	24.3309.0.000	3-7	28	1
				24.0069.9.034	23	23	1				
<b>23.2044.0.050</b>				24.0069.9.037	18	18	1	<b>24.3310.0.000</b>			
23.2044.0.050	3-25	08	1	24.0069.9.038	1	01	1	24.3310.0.000	3-5	31	1
23.2106.0.000	3-15	09	1	24.0069.9.039	07	07	(1)	24.3311.0.000	3-7	07	1
23.2107.0.000	3-15	12	1	24.0080.0.000	32	32	1	24.3312.0.000	3-7	08	1
				24.0097.0.000	7	07	(1)	24.3313.0.000	3-7	09	1
<b>24.0001.0.000</b>								24.3314.0.000	3-7	20	1
24.0001.0.000	3-3	33	1	<b>24.0100.0.000</b>				24.3315.0.000	3-7	22	1
24.0002.0.000	3-3	28	1	24.0100.0.000	36	36	1	24.3316.0.000	3-7	38	1
24.0002.0.000	3-27	20	1	24.0106.0.000	40	40	1	24.3317.0.000	3-7	37	1
24.0003.0.000	3-7	14	1	24.0108.0.000	26	26	1	24.3318.0.000	3-27	23	1
24.0004.0.000	3-7	15	1	24.0111.0.000	01	01	1	24.3319.0.000	3-7	26	1
24.0005.0.000	3-7	04	1	24.0112.0.000	11	11	1	24.3320.0.000	3-7	13	1
24.0006.0.000	3-7	11	1	24.0126.0.000	05	05	1	24.3321.0.000	3-7	17	1
24.0009.0.000	3-21	09	1	24.0127.0.000	42	42	1	24.3321.0.000	3-15	03	1
				24.0139.0.000	02	02	1	24.3322.0.000	3-15	05	2
<b>24.0010.0.000</b>				24.0140.0.000	60	60	1	24.3324.0.000	3-25	19	1
24.0010.0.000	3-21	08	1	24.0141.0.000	01	01	1	24.3325.1.000	3-35	43	1
24.0011.0.000	3-21	05	1	24.0146.0.000	8	08	(1)	24.3326.0.000	3-43	37	1
24.0014.0.000	3-21	06	1								

Revised 10/2011

e-mail: [service@amfreece.cz](mailto:service@amfreece.cz); [parts@amfreece.cz](mailto:parts@amfreece.cz); website: [www.amfreece.com](http://www.amfreece.com)

Phone: +420 582 309 286; Fax: +420 582 360 606

# INDEX

PART NUMBER	PAGE	DET	QTY	PART NUMBER	PAGE	DET	QTY	PART NUMBER	PAGE	DET	QTY
24.3326.1.000	3-43	33	1								
24.3327.0.000	3-45	06	1								
<b>24.6000.5.000</b>											
24.6000.5.000	3-25	01	1								
24.6001.2.000	3-29	10	1								
24.6003.0.000	3-29	13	1								
24.6004.1.001	3-29	06	1								
24.6005.1.001	3-17	15	1								
24.6100.1.000	3-27	06	1								
24.8001.2.001	3-41	06	1								
24.8001.2.002	3-35	11	(1)								
24.8001.2.005	3-41	04									

Revised 10/2011

e-mail: [service@amfreece.cz](mailto:service@amfreece.cz); [parts@amfreece.cz](mailto:parts@amfreece.cz); website: [www.amfreece.com](http://www.amfreece.com)

Phone: +420 582 309 286; Fax: +420 582 360 606