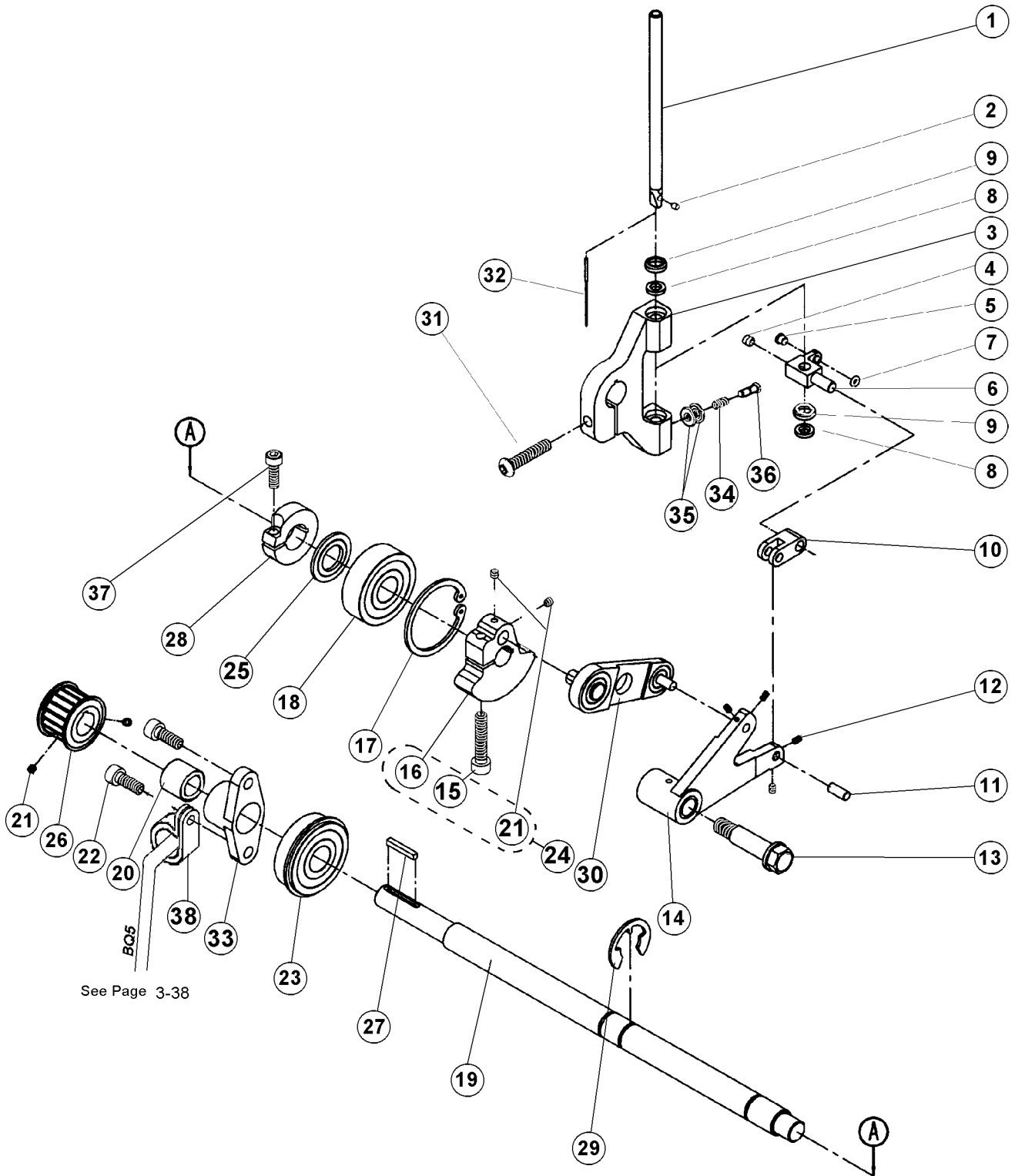

TABLE OF CONTENTS

Needle Bar	3-2
Clamping	3-4
Thread Trimmer	3-6
Shifter Mechanism	3-8
Feed Mechanism	3-10
Looper Mechanism	3-14
Base	3-16
Bite Mechanism	3-18
Knife and Draw	3-20
Main Cam	3-24
Head Assembly	3-26
Bedplate	3-28
Covers	3-32
Lubrication	3-34
Table	3-36
Electrical — I	3-38
Electrical — II	3-42
Electrical — III	3-44
Pneumatics	3-46
Accessories	3-48
Extra Parts	3-50

NEEDLE BAR



Revised 10/2009

e-mail: service@amfreece.cz; parts@amfreece.cz; website: www.amfreece.com

Phones: +420 582 309 146 (Service), +420 582 309 286 (Spare Parts); Fax: +420 582 360 606

NEEDLE BAR

DET	PART NUMBER	DESCRIPTION	QTY.
1	24.0195.4.000	Needle Bar	1
2	01.2193.0.000	4-60 Screw	1
3	24.0510.0.000	Needle Bar Holder ●	1
4	08.6400.5.005	M5 x 5 Set Screw	1
5	01.7447.1.000	Porcelain Guide ●●●	1
6	22.0520.0.000	Needle Bar Clamp	1
7	01.6551.0.000	Retaining Ring ●●●	1
8	22.0230.0.000	Cupped Washer ●●●	2
9	22.0239.0.000	Felt Washer	2
10	22.0530.0.000	Needle Bar Connecting Link	1
11	22.0542.0.000	Needle Bar Connecting Link Pin	1
12	08.6400.3.005	M3 x 5 Set Screw	4
13	22.0541.0.000	Needle Bar Shoulder Screw	1
14	22.0540.0.000	Needle Bar Connecting Link Pin ●●●	1
15	08.6000.6.030	M6 x 30 Screw	(1)
16	22.0525.0.000	Needle Bar Crank ●	(1)
17	01.7809.0.000	Retaining Ring	1
18	01.7804.0.000	Top Shaft Bearing	1
19	24.0500.0.000	Needle Bar Drive Shaft	1
20	12.2050.0.003	Bearing	1
21	08.6400.4.004	M4 x 4 Set Screw	2 (2)
22	08.6000.6.016	M6 x 16 Screw	2
23	01.7805.0.000	Shaft Bearing	1
24	22.0525.0.050	Needle Bar Crank Asm.	1
25	22.0545.0.000	Washer	1
26	24.0048.0.000	Needle Bar Drive Pulley ●	1
27	22.0175.0.000	Drive Shaft Key	1
28	24.0002.0.000	Clamp Collar	1
29	12.1045.2.001	Retaining Ring	1
30	22.0535.0.100	Needle Bar Crank Link Asm. ●	1
31	08.6000.6.025	M6 x 25 Screw	1
32	02.0750.2.109	Needle	1
33	24.0001.0.000	Bearing Carrier Upper Shaft	1
34	17.0026.2.077	Spring	1
35	17.0082.8.017	Washer	2
36	24.0100.0.000	M3.5 x 0.35-11 Screw	1
37	08.6000.5.016	M5 x 16 Screw	1
38	See page 3-38	Plastic Cable Fitting	1

Revised 10/2009

e-mail: service@amfreece.cz; parts@amfreece.cz; website: www.amfreece.com

Phones: +420 582 309 146 (Service), +420 582 309 286 (Spare Parts); Fax: +420 582 360 606

CLAMPING

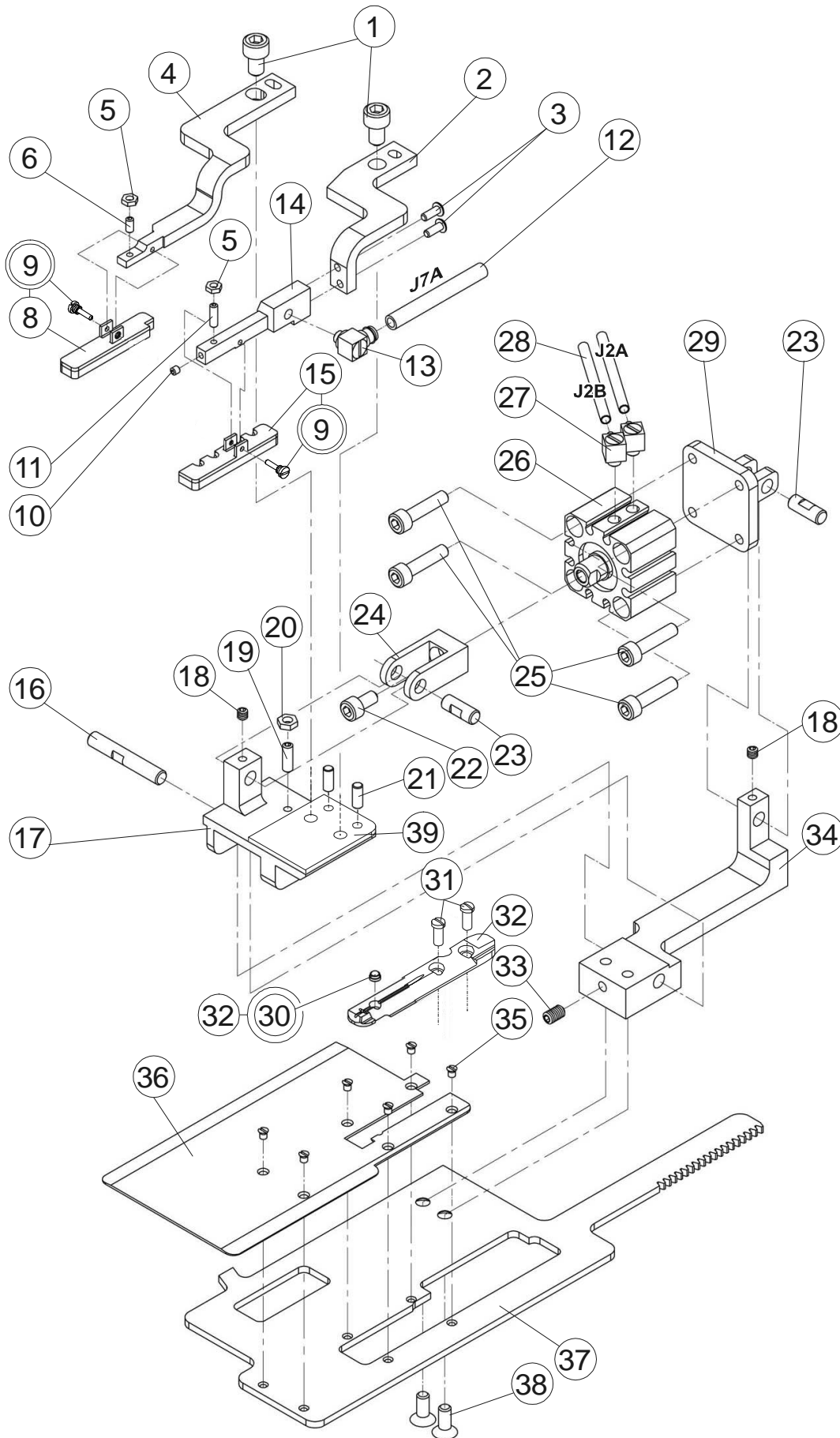

Revised 03/2014

e-mail: service@amfreece.cz; parts@amfreece.cz; website: www.amfreece.com
Phone: +420 582 309 286; Fax: +420 582 360 606

CLAMPING

DET	PART NUMBER	DESCRIPTION	QTY.
01	08.6000.6.012	M6x10 Screw	2
02	24.0227.4.000	R.H. Clamp Arm	1
03	08.6200.3.008	M3x8 Screw	2
04	24.0226.4.000	L.H. Clamp Arm	1
05	08.6710.3.000	M3 Nut	2
06	08.6400.3.006	M3x6 Set Screw	1
07			
08	24.2073.2.000	L.H. Clamp Foot ●●●	1
09	24.2076.0.000	Screw M3,5x0,35	2
10	08.6400.3.004	M3x4 Set Screw	1
11	08.6400.3.010	M3x10 Set Screw	1
12	See page 3-46	Air Tubing ●●●	-
13	See page 3-46	Connector ●	-
14	24.2064.0.000	Clamp Arm Extension	1
15	24.2074.0.000	R.H.Clamp Foot ●●●	1
16	22.0159.0.000	Tail Pivot Clamp Pin	1
17	24.0157.0.000	Tail Pivot Clamp	1
18	08.6400.4.004	M4x4 Set Screw	2
19	08.6400.4.012	M4x12 Set Screw	1
20	08.6700.4.000	M4 Nut	1
21	07.6045.0.046	Pin	2
22	08.6000.5.010	M5x10 Screw	1
23	22.0173.0.000	Clamp Toggle Pivot Pin	2
24	24.2038.0.000	Cylinder Clevis	1
25	08.6000.5.022	M5x22 Screw	4
26	See page 3-46	Cylinder ●	-
27	See page 3-46	Connector ●	-
28	See page 3-46	Air Tubing ●●●	-
29	24.0036.0.000	Cylinder Mounting Bracket	1
30	12.0008.4.477	Glass Eye ●●● (1)	(1)
31	01.2084.0.000	Screw	2
32	24.2075.3.000	Throat Plate CAED	1
33	08.6400.5.008	M5x8 Set Screw	1
34	24.0158.0.000	Tail Bracket Clamp	1
35	01.2376.0.000	Screw	6
36	24.6102.4.004	Loading Plate	1
37	24.0125.6.000	Clamp Plate CAED	1
38	08.6100.5.012	M5x12 Screw	2
39	24.2058.0.000	Distance Plate	1

Revised 10/2009

e-mail: service@amfreece.cz; parts@amfreece.cz; website: www.amfreece.com

Phones: +420 582 309 146 (Service), +420 582 309 286 (Spare Parts); Fax: +420 582 360 606

THREAD TRIMMER

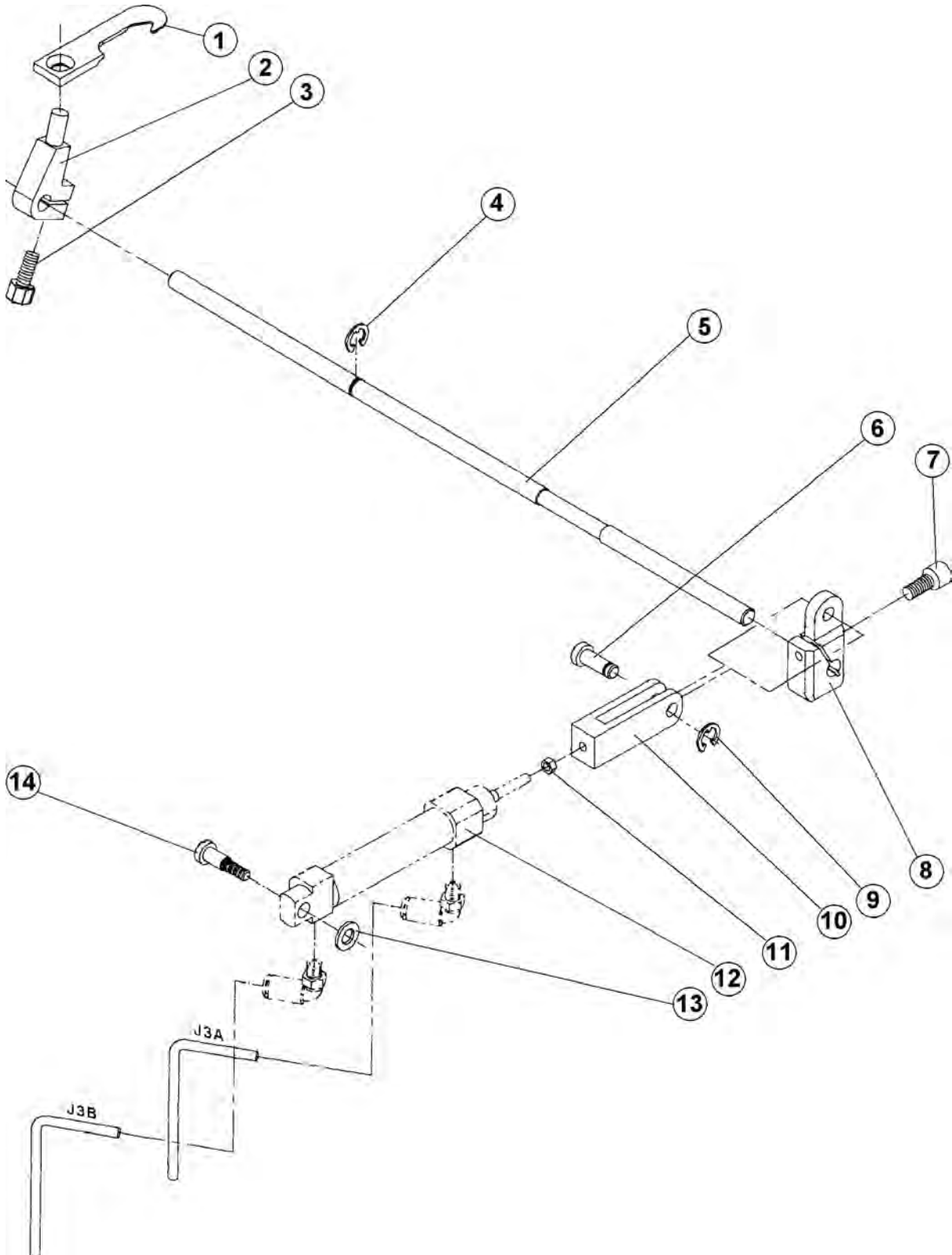

Revised 10/2009

e-mail: service@amfreece.cz; parts@amfreece.cz; website: www.amfreece.com

Phones: +420 582 309 146 (Service), +420 582 309 286 (Spare Parts); Fax: +420 582 360 606

SHIFTER MECHANISM

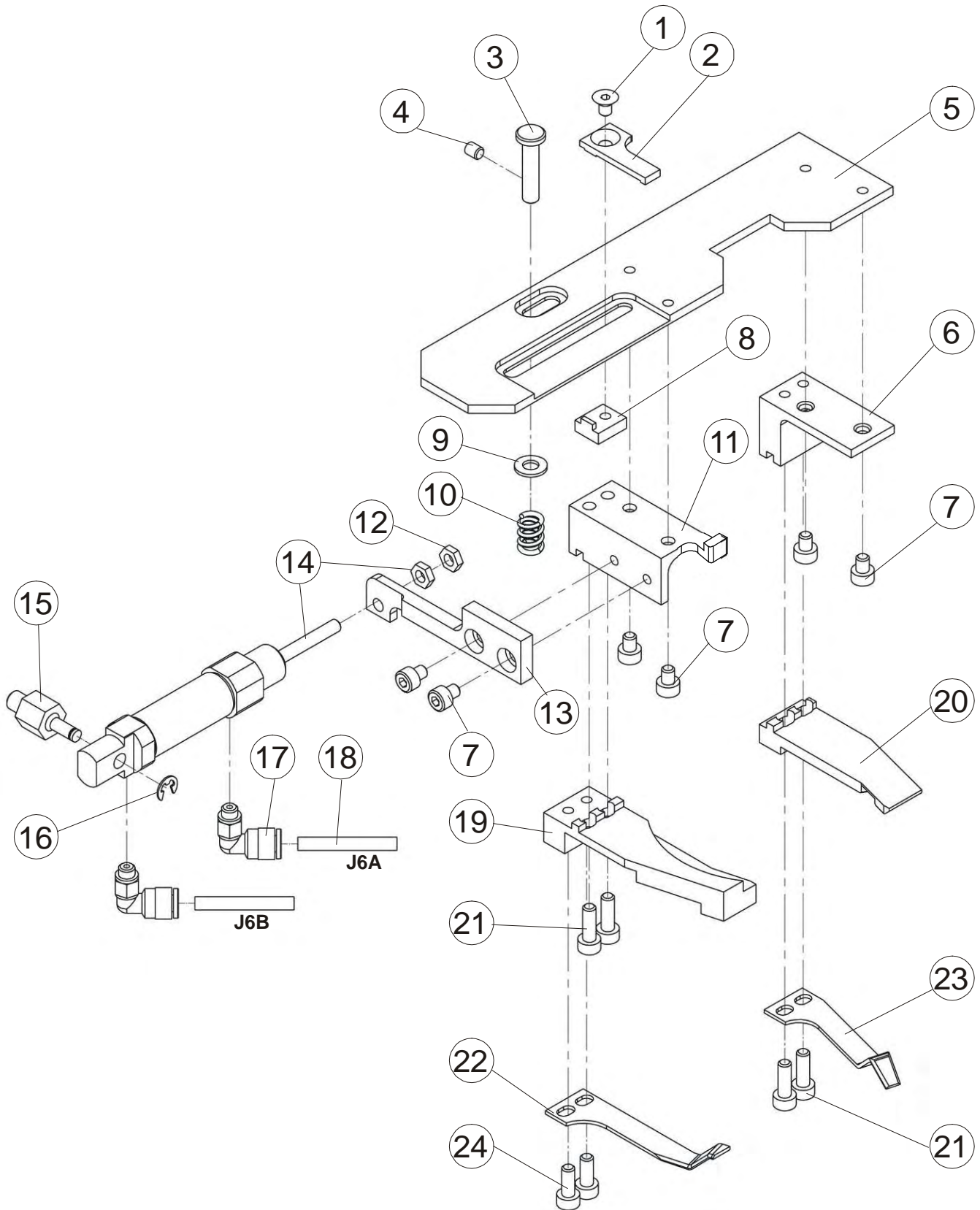

Revised 10/2009

e-mail: service@amfreece.cz; parts@amfreece.cz; website: www.amfreece.com

Phones: +420 582 309 146 (Service), +420 582 309 286 (Spare Parts); Fax: +420 582 360 606

SHIFTER MECHANISM

DET	PART NUMBER	DESCRIPTION	QTY.
1	08.6100.4.006	M4x6 Screw	1
2	24.2664.4.000	Buttonhole Adjusting Link	1
3	22.0400.0.000	Spring Load Pin	1
4	08.6400.4.005	M4x5 Set Screw	1
5	22.2665.0.000	Main Cam Shifter Plate	1
6	22.2655.0.000	Right Shifter Block	1
7	08.6000.4.005	M4x5 Screw	6
8	22.0405.2.000	Adjustable Link Nut	1
9	08.6887.5.000	Washer M5	1
10	07.6440.0.040	Spring	1
11	24.2651.4.001	Left Shifter Block	1
12	08.6710.4.000	Nut M4	1
13	24.2016.0.000	Shifter Pull Of Bracket	1
14	See Page 3-46	Cylinder ●	-
15	24.2017.0.000	Air Cylinder Mounting Post	1
16	07.6045.0.047	E-clip	1
17	See Page 3-46	Conector ●●●	-
18	See Page 3-46	Air Tubing ●●●	-
19	22.2652.0.000	Left Shifter Arm	1
20	22.2656.0.000	Right Shifter Arm	1
21	08.6000.4.016	M4x16 Screw	4
22	22.2653.0.000	Left Shifter Arm Spring	1
23	22.2657.0.000	Right Shifter Arm Spring	1
24	08.6000.4.010	M4x10 Screw	2

Revised 10/2009

e-mail: service@amfreece.cz; parts@amfreece.cz; website: www.amfreece.com

Phones: +420 582 309 146 (Service), +420 582 309 286 (Spare Parts); Fax: +420 582 360 606

FEED MECHANISM

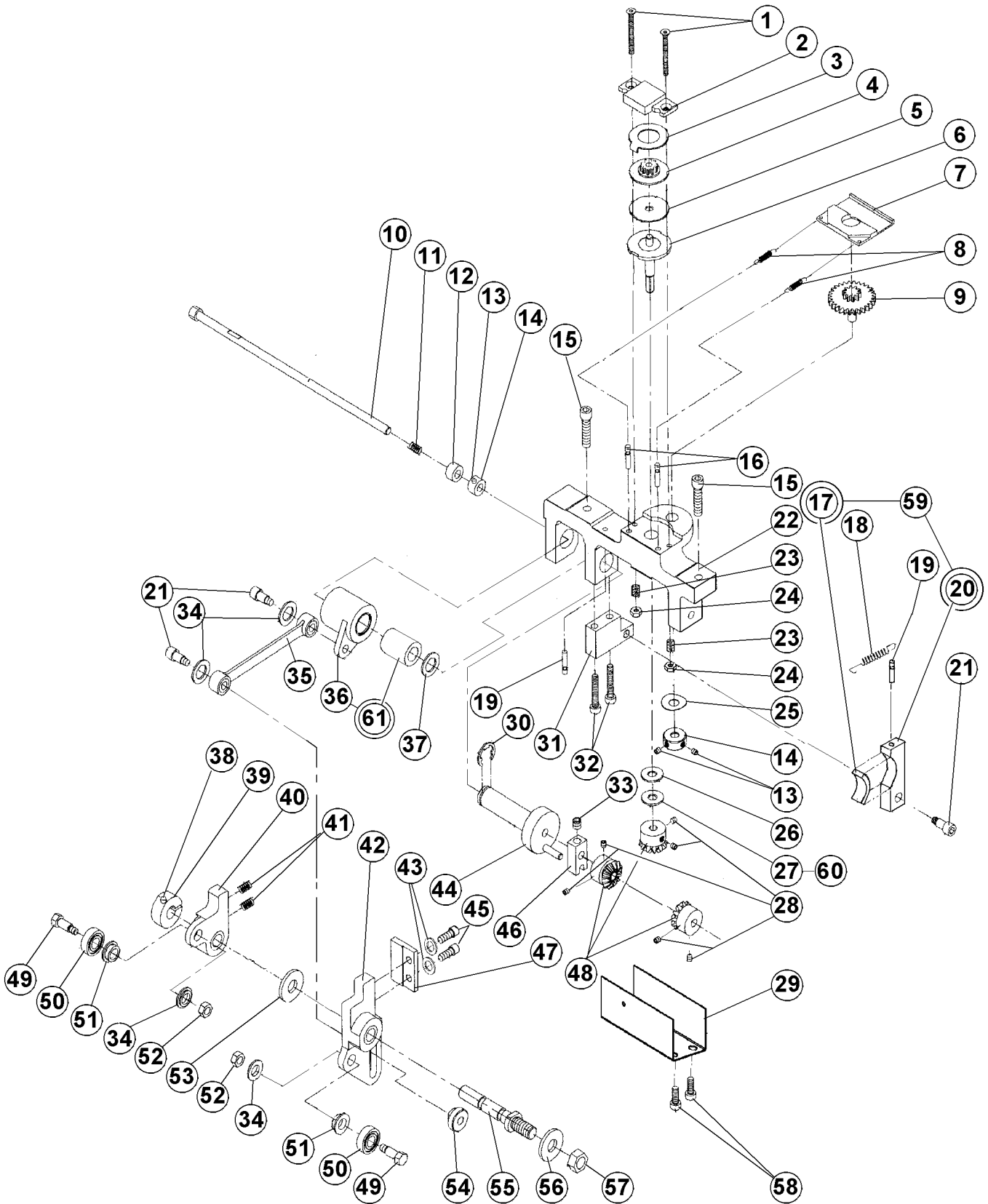

Revised 10/2009

e-mail: service@amfreece.cz; parts@amfreece.cz; website: www.amfreece.com

Phones: +420 582 309 146 (Service), +420 582 309 286 (Spare Parts); Fax: +420 582 360 606

FEED MECHANISM

DET	PART NUMBER	DESCRIPTION	QTY.
01	08.6100.3.030	M3 x 30 Screw	2
02	22.0114.0.000	Feed Brake Pressure Plate	1
03	22.0121.0.000	Slip Clutch Drive Washer	1
04	22.0354.0.000	Slip Clutch Feed Gear	1
05	24.0126.0.000	Friction Washer ●●●	1
06	22.0312.0.000	Slip Clutch Feed Shaft	1
07	22.0061.0.000	Clamp Plate Gear Rack Retainer	1
08	07.6440.0.033	Spring	2
09	24.0351.0.000	Feed Gear Assembly	1
10	22.0325.0.000	Feed Reversing Shaft	1
11	07.6440.0.041	Spring	1
12	22.0228.0.000	Collar	1
13	08.6400.5.305	M5 x 0,5 - 5 Set Screw	4
14	24.0049.0.000	Set Collar	2
15	08.6000.5.020	M5 x 20 Screw	2
16	07.6045.0.037	3 x 16 Grooved Pin	2
17	22.0313.0.000	Feed Brake Pad ●●●	(1)
18	07.6440.0.050	Spring	1
19	07.6045.0.009	3 x 12mm Pin	2
20	22.0309.0.000	Feed Brake	(1)
21	22.0184.0.000	M5 x 8 Screw	3
22	22.0315.0.000	Feed Shaft Bracket ●●	1
23	07.6440.0.028	Spring	2
24	08.6733.3.000	M3 Lock Nut	2
25	17.0019.2.057	Lockwasher	1
26	22.0208.0.000	Flat Washer	1
27	22.0186.0.000	Washer Dia. 5.2/17-0.2	1
28	08.6400.4.005	M4 x 5 Set Screw	6
29	24.2035.0.000	Gear Cover	1
30	07.6045.0.034	E-Ring	1
31	22.0049.0.000	Feed Brake Mounting Block ●	1
32	08.6000.4.025	M4 x 25 Screw	2
33	08.6400.5.005	M5 x 5 Set Screw	1
34	22.0100.0.000	Shoulder Washer	4
35	22.0305.0.000	Feed Connecting Link ● ●●	1
36	22.0320.0.000	Feed Shaft Bearing Housing	1
37	17.0019.0.517	Washer	1
38	08.6000.3.010	M3 x 10 Screw	1
39	22.0183.0.000	Collar Dia. 8	1
40	22.0026.0.000	L.H. Feed Cam Follower ● ●●	1
41	07.6440.0.018	Spring	2
42	24.0127.0.000	R.H. Feed Cam Follower ● ●●	1
43	08.6800.4.000	M4 Lockwasher	2
44	22.0336.0.000	Feed Shaft	1
45	08.6000.4.014	M4 x 14 Screw	2
46	22.0370.0.000	Feed Crank	1
47	22.0021.0.000	Spring Retain Block	1
48	22.0353.0.000	Steel Bevel Gear ●	3
49	22.0032.0.000	Bearing Shoulder Screw	2
50	07.6321.0.025	Bearing	2

Revised 10/2009

e-mail: service@amfreece.cz; parts@amfreece.cz; website: www.amfreece.com

Phones: +420 582 309 146 (Service), +420 582 309 286 (Spare Parts); Fax: +420 582 360 606

FEED MECHANISM

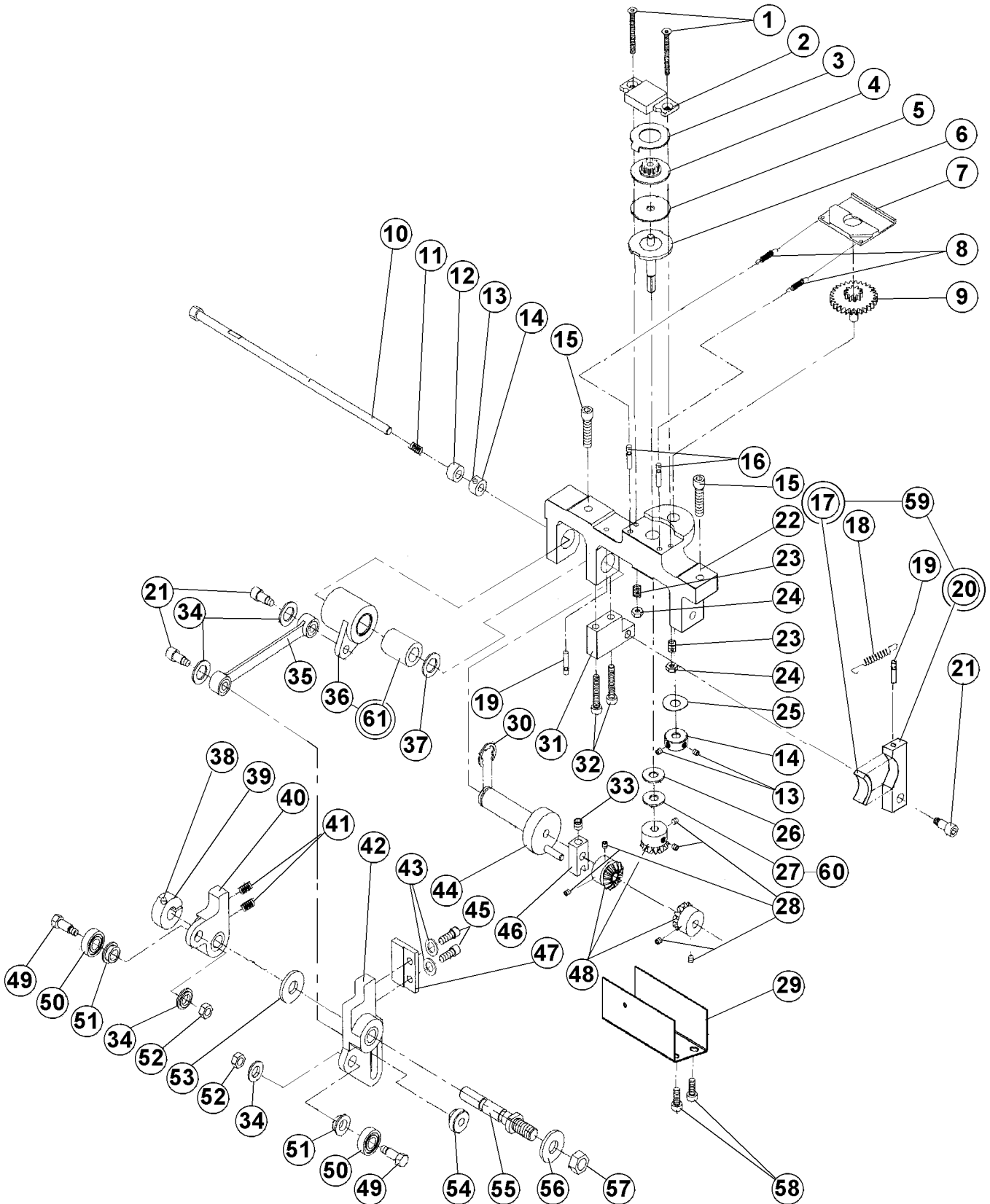

Revised 10/2009

e-mail: service@amfreece.cz; parts@amfreece.cz; website: www.amfreece.com

Phones: +420 582 309 146 (Service), +420 582 309 286 (Spare Parts); Fax: +420 582 360 606

FEED MECHANISM



DET	PART NUMBER	DESCRIPTION	QTY.
51	22.0031.0.000	Bearing Spacer	2
52	08.6710.5.000	M5 Nut	2
53	22.0232.0.000	Washer	1
54	22.0110.0.000	M5 Shoulder Nut	1
55	22.0022.0.000	Pivot Shaft	1
56	08.6850.8.000	M8 Flat Washer	1
57	08.6700.8.000	M8 Nut	1
58	08.6000.4.005	M4 x 5 Screw	2
59	22.0309.0.050	Feed Brake Assembly	1
60	24.0140.0.000	Washer Dia. 5.2/17-0.1	1
61	07.6321.0.030	Bearing	(1).

Revised 10/2009

e-mail: service@amfreece.cz; parts@amfreece.cz; website: www.amfreece.com

Phones: +420 582 309 146 (Service), +420 582 309 286 (Spare Parts); Fax: +420 582 360 606

LOOPER MECHANISM

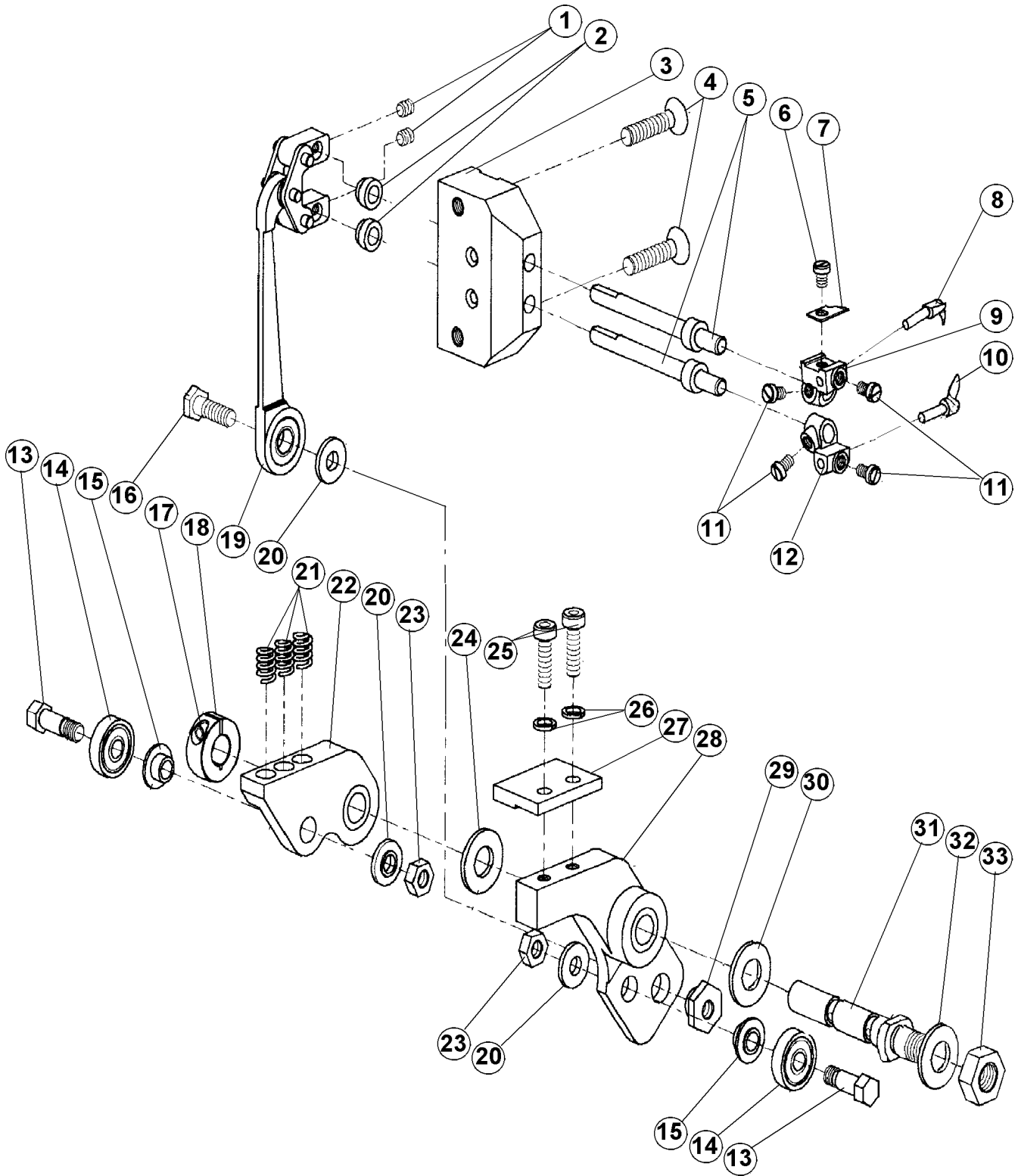

Revised 10/2009

e-mail: service@amfreece.cz; parts@amfreece.cz; website: www.amfreece.com

Phones: +420 582 309 146 (Service), +420 582 309 286 (Spare Parts); Fax: +420 582 360 606

LOOPER MECHANISM

DET	PART NUMBER	DESCRIPTION	QTY.
01	08.6400.4.004	M4 x 4 Set Screw	2
02	22.2442.0.000	Looper Spacer	2
03	22.2410.0.000	Looper Shaft Block	1
04	08.6100.5.020	M5 x 20 Screw	2
05	22.2440.0.000	Looper Shaft	2
06	01.1382.0.000	Screw	1
07	20.0094.0.000	Trimmer Knife	1
08	20.0111.0.000	First Looper	1
09	23.2106.0.000	First Looper Holder	1
10	20.0112.0.000	Second Looper	1
11	01.1397.0.000	Screw	4
12	23.2107.0.000	Second Looper Holder	1
13	24.0066.0.000	Bearing Screw	2
14	12.2010.1.002	Cam Follower Bearing	2
15	22.0031.0.000	Bearing Spacer	2
16	22.0064.0.000	Bite Shoulder Screw	1
17	08.6000.3.010	M3 x 10 Screw	1
18	22.0183.0.000	Collar	1
19	22.2425.0.050	Looper Link Assembly	1
20	22.0100.0.000	Shoulder Washer	3
21	07.6440.0.036	Spring	3
22	22.0024.0.000	Looper Cam Follower Plate ● ● ●	1
23	08.6710.5.000	M5 Hex Nut	2
24	22.0232.0.000	Flat Washer	1
25	08.6000.4.014	M4 x 14 Screw	2
26	08.6800.4.000	M4 Lockwasher	2
27	22.0021.0.000	Spring Retainer Block	1
28	22.0023.0.000	R.H. Looper Cam Follower Plate ● ● ●	1
29	22.0105.0.000	Looper Eccentric Nut	1
30	22.0233.0.000	Flat Washer	1
31	22.0022.0.000	Pivot Shaft	1
32	08.6850.8.000	M8 Flat Washer	1
33	08.6700.8.000	M8 Hex Nut	1

Revised 10/2009

e-mail: service@amfreece.cz; parts@amfreece.cz; website: www.amfreece.com

Phones: +420 582 309 146 (Service), +420 582 309 286 (Spare Parts); Fax: +420 582 360 606

BASE

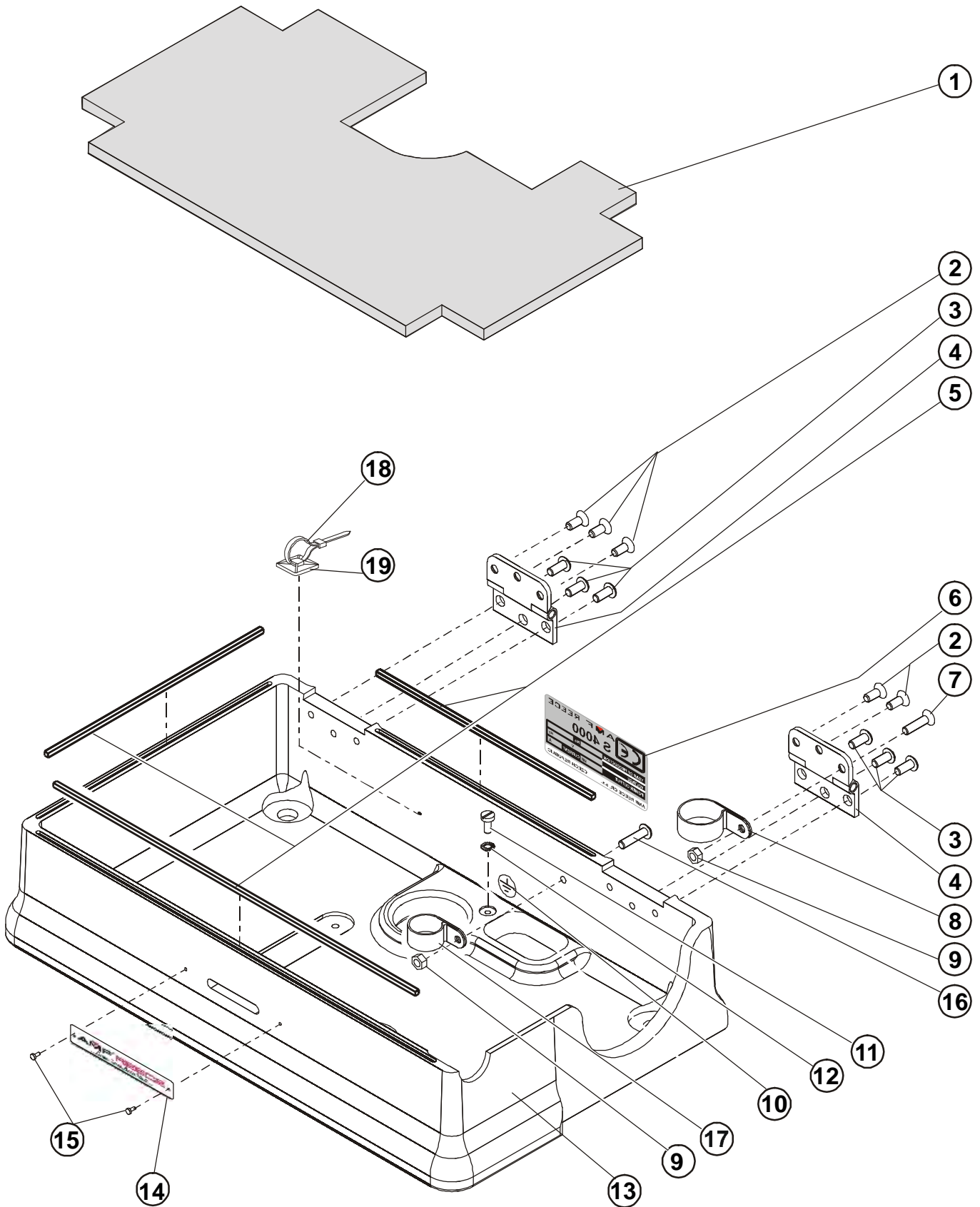

Revised 10/2009

e-mail: service@amfreece.cz; parts@amfreece.cz; website: www.amfreece.com

Phones: +420 582 309 146 (Service), +420 582 309 286 (Spare Parts); Fax: +420 582 360 606

BASE

DET	PART NUMBER	DESCRIPTION	QTY.
01	24.0111.0.000	Base Sound Deadener ●●●	1
02	08.6100.5.012	M5 x 12 Screw	5
03	08.6200.5.012	M5 x 12 Screw	6
04	22.1010.0.000	Base Hinge	2
05	24.0038.0.000	Base Gasket ●●●	1
06	12.8000.1.028	CE"" Label	1
07	08.6100.5.020	M5 x 20 Screw	1
08	12.0008.4.197	Cord Clamp ●●●	1
09	08.6700.5.000	M5 Nut	2
10	12.0008.4.052	Label (Ground)	1
11	08.6012.4.010	M4 x 10 Screw	1
12	08.6832.4.000	M4 Serrated Lockwasher	1
13	24.6005.1.002	Base	1
14	—	Label ●	1
15	—	Drive Screw ●	2
16	08.6200.5.020	Screw	1
17	12.0010.4.013	Cord Clamp ●●●	1
18	12.0008.3.023	Ty-wrap ●●●	2
19	12.0008.4.058	Clip ●●●	1

Revised 10/2009

e-mail: service@amfreece.cz; parts@amfreece.cz; website: www.amfreece.com

Phones: +420 582 309 146 (Service), +420 582 309 286 (Spare Parts); Fax: +420 582 360 606

BITE MECHANISM

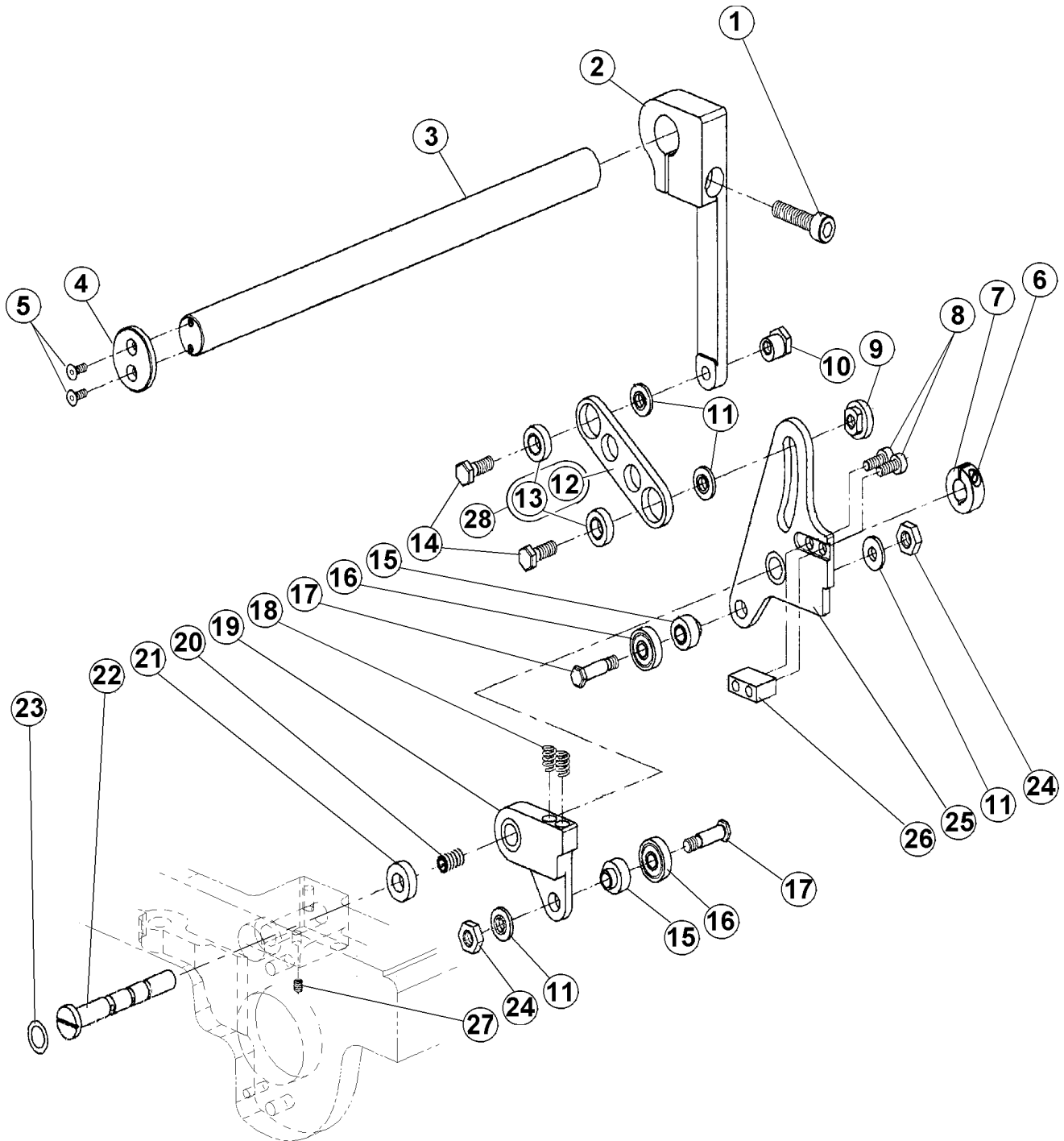

Revised 10/2009

e-mail: service@amfreece.cz; parts@amfreece.cz; website: www.amfreece.com

Phones: +420 582 309 146 (Service), +420 582 309 286 (Spare Parts); Fax: +420 582 360 606

BITE MECHANISM

DET	PART NUMBER	DESCRIPTION	QTY.
01	08.6000.6.025	M6 x 25 Screw	1
02	22.0008.0.000	Bite Lever ●	1
03	22.0005.0.000	Bite Shaft	1
04	22.0063.0.000	Bite Shaft Retainer	1
05	08.6100.3.008	M3 x 8 FH Screw	2
06	08.6000.3.010	M3 x 10 Screw	1
07	22.0183.0.000	Collar*Dia. 8	1
08	08.6000.4.014	M4 x 14 Screw	2
09	22.0110.0.000	M5 Shoulder Nut	1
10	22.0214.0.000	M5 Eccentric Nut	1
11	22.0100.0.000	Shoulder Washer	4
12	22.0009.0.000	Bite Adjusting Link ●	(1)
13	07.6321.0.029	Bearing	(2)
14	22.0064.0.000	Bite Shoulder Screw	2
15	22.0029.0.000	Bite Follower Bearing Spacer	2
16	07.6321.0.025	Bearing	2
17	22.0028.0.000	Bite Follower Bearing Screw	2
18	07.6440.0.028	Spring	2
19	22.0027.0.000	Right Cam Follower ● ● ●	1
20	08.6400.4.005	M4 x 5 Set Screw	1
21	22.0069.0.000	Bite Follower Spacer	1
22	22.0020.0.000	Bite Pivot Shaft	1
23	12.0008.6.800	Rubber Ring ● ● ●	1
24	08.6700.5.000	M5 Hex Nut	2
25	24.0033.0.000	Left Cam Follower ● ● ●	1
26	22.0030.0.000	Bite Follower Spring Retainer	1
27	08.6400.4.004	M4x4 Screw	1
28	22.0009.0.050	Bite Adjusting Link Assembly	1

Revised 01/2010

e-mail: service@amfreece.cz; parts@amfreece.cz; website: www.amfreece.com

Phones: +420 582 309 146 (Service), +420 582 309 286 (Spare Parts); Fax: +420 582 360 606

KNIFE AND DRAW

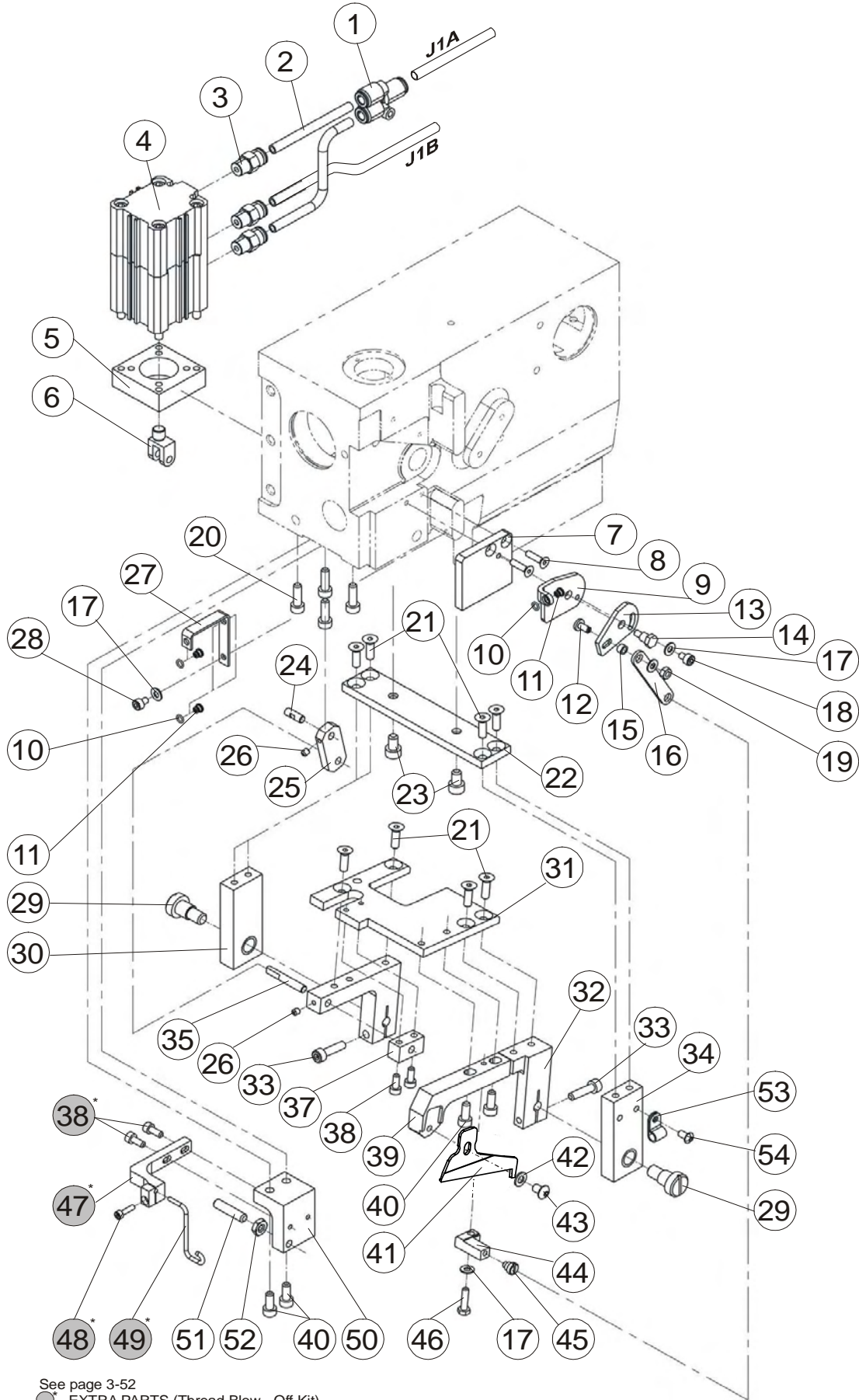

See page 3-52
* - EXTRA PARTS (Thread Blow - Off Kit)

Revised 10/2009

e-mail: service@amfreece.cz; parts@amfreece.cz; website: www.amfreece.com

Phones: +420 582 309 146 (Service), +420 582 309 286 (Spare Parts); Fax: +420 582 360 606

KNIFE AND DRAW

DET	PART NUMBER	DESCRIPTION		QTY.
1	See page 3-46	Connector	●●●	-
2	See page 3-46	Air Tubing	●●●	-
3	See page 3-46	Connector	●●●	-
4	See page 3-46	Cylinder	●	-
5	24.2069.0.000	Cylinder Stand-Off		1
6	24.2014.0.000	Knife Drive Lever		1
7	24.2053.0.000	Thread Take-Up Plate		1
8	08.6100.4.014	M4x14 Screw		2
9	24.2042.0.000	Thread Take-Up		1
10	01.6551.0.000	Retaining Ring	●●●	3
11	01.7447.1.000	Guide	●●●	3
12	24.2044.0.000	Screw-Thread Draw-Off Link		1
13	24.2043.0.000	Thread Draw-Off		1
14	24.2047.0.000	Pivot, Draw-Off		1
15	24.2045.0.000	Bearing		1
16	24.2046.0.000	Thread Draw-Off Lever		1
17	08.6850.4.000	Washer M4		4
18	08.6000.4.006	M4x6 Screw		1
19	08.6700.4.000	Nut M4		1
20	08.6000.5.016	M5x16 Screw		4
21	08.6100.5.016	M5x16 Screw		8
22	24.2001.0.000	Base Plate		1
23	08.6000.6.010	M6x10 Screw		2
24	24.2015.0.000	Clevis Pin		1
25	24.2013.0.000	Clevis Link		1
26	08.6400.4.004	M4x4 Set Screw		2
27	24.2048.0.000	Thread Guide Bracket		1
28	08.6000.4.005	M4x5 Screw		1
29	24.2004.0.000	Adjusting Screw		2
30	24.2002.0.000	Plate Leg, Right Assy.	●●	1
31	24.2005.0.000	Bridge Plate		1
32	24.2007.0.000	Knife Pivot Leg		1
33	08.6000.5.020	M5x20 Screw		2
34	24.2028.0.000	Plate Leg, Right Assy.	●●	1
35	24.2009.0.000	Knife Link Pin		1
36	24.2006.0.000	Bridge Support		1
37	24.2008.0.000	Clevis Link Support		1
38*	08.6000.4.010	M4x10 Screw		4
39	24.2010.0.000	Knife Lever		1
40	08.6000.5.012	M5x12 Screw		4
41	24.2071.2.000	Knife - 90		1
42	08.6850.5.000	Washer M5		1
43	08.6200.5.006	M5x6 Screw		1
44	24.2049.0.000	Thread Take-Up Link Holder		1
45	24.2012.0.000	Thread Draw-Off Shoulder Screw		1
46	08.6310.4.014	M4x14 Screw		1
47*	24.2068.0.000	Bracket		1
48*	08.6000.3.012	M3x12 Screw		1
49*	24.2067.0.000	Thread Holder		1
50	24.2050.0.000	Cutting Lever Block		1
* - EXTRA PARTS				

Revised 10/2009

e-mail: service@amfreece.cz; parts@amfreece.cz; website: www.amfreece.com

Phones: +420 582 309 146 (Service), +420 582 309 286 (Spare Parts); Fax: +420 582 360 606



KNIFE AND DRAW

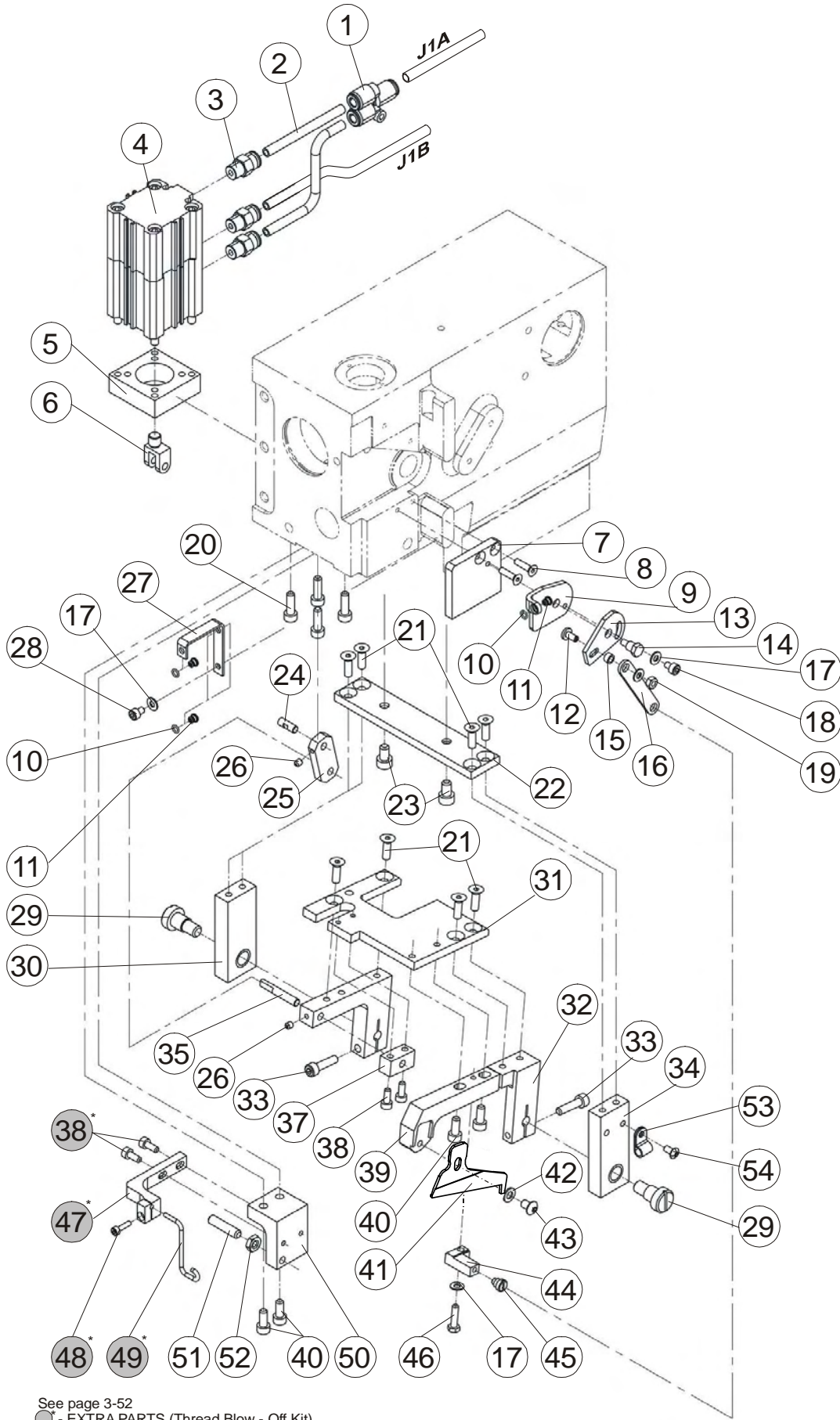

See page 3-52
● - EXTRA PARTS (Thread Blow - Off Kit)

Revised 10/2009

e-mail: service@amfreece.cz; parts@amfreece.cz; website: www.amfreece.com

Phones: +420 582 309 146 (Service), +420 582 309 286 (Spare Parts); Fax: +420 582 360 606

KNIFE AND DRAW



DET	PART NUMBER	DESCRIPTION	QTY.
51	08.6490.6.025	M6x25 Screw	1
52	08.6710.6.000	Nut M6	1
53	12.0008.4.280	Clamp ●●●	1
54	08.6200.4.008	M4x8 Screw	1

--	--	--	--

* - EXTRA PARTS

Revised 10/2009

e-mail: service@amfreece.cz; parts@amfreece.cz; website: www.amfreece.com

Phones: +420 582 309 146 (Service), +420 582 309 286 (Spare Parts); Fax: +420 582 360 606

MAIN CAM

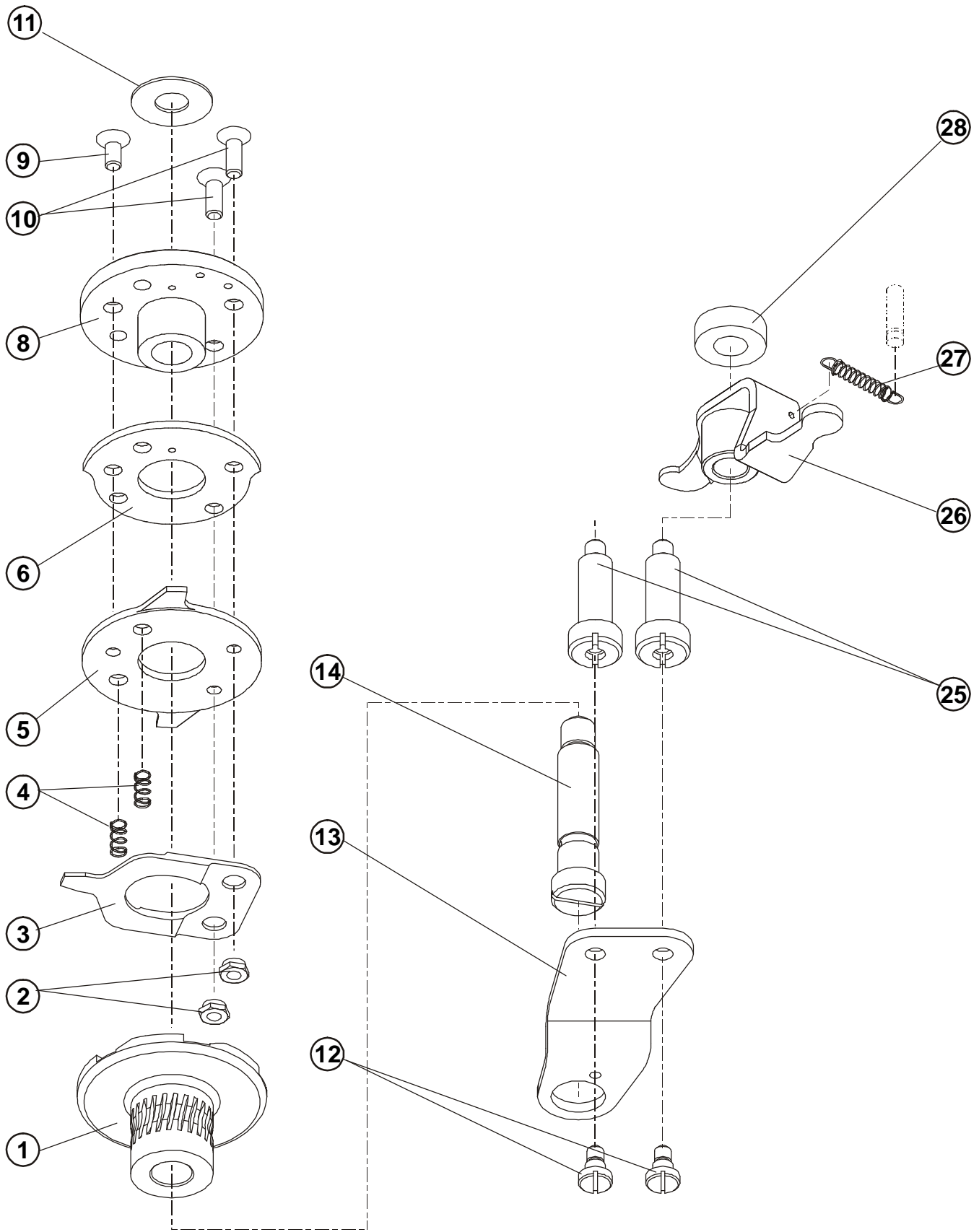

MAIN CAM

DET	PART NUMBER	DESCRIPTION	QTY.
01	22.2607.0.000	Drive Disk/Worm Gear Hub	1
02	22.2627.0.000	Shoulder Nut	2
03	22.2626.0.000	Drive Disk Switch Spring	1
04	07.6440.0.037	Spring	2
05	24.2040.0.000	Stop Disk	1
06	24.3201.0.000	Feed Reversing Cam	1
08	24.3203.0.000	Barring Cam	1
09	08.6100.5.010	M5 x 10 Screw	1
10	22.0137.0.000	M5 x 14 Screw	2
11	07.6321.0.001	Thrust Washer	1
12	22.0182.0.000	M5 x 4 Screw	2
13	22.0097.0.000	Main Cam Brace	1
25	22.0106.0.000	Hub Shoulder Screw	2
26	24.2640.2.000	Feed Reversing Lever	1
27	07.6440.0.045	Extension Spring	1
28	22.3003.0.000	Spacer	1

Revised 10/2009

e-mail: service@amfreece.cz; parts@amfreece.cz; website: www.amfreece.com

Phones: +420 582 309 146 (Service), +420 582 309 286 (Spare Parts); Fax: +420 582 360 606

HEAD ASSEMBLY

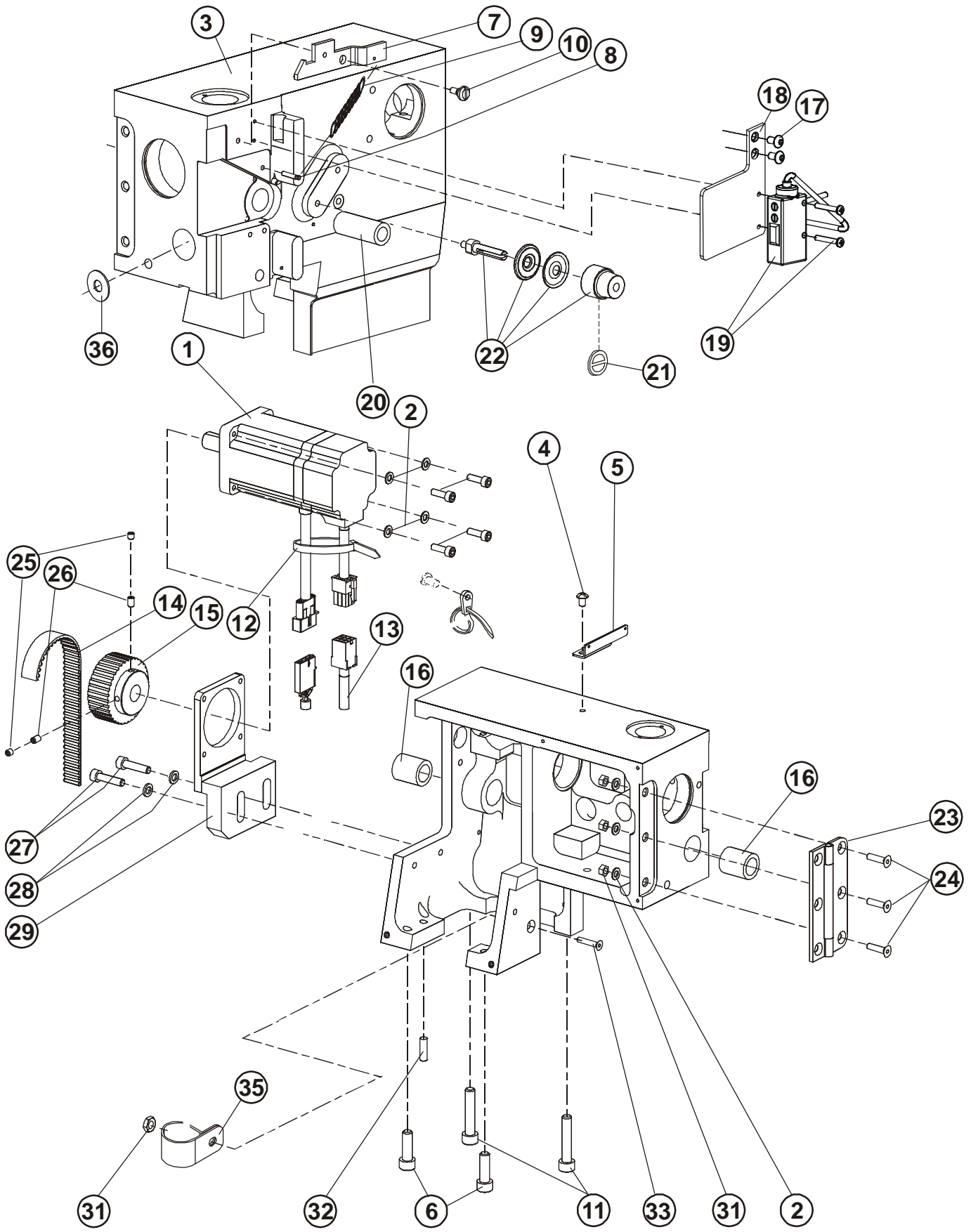

Revised 10/2009

e-mail: service@amfreece.cz; parts@amfreece.cz; website: www.amfreece.com

Phones: +420 582 309 146 (Service), +420 582 309 286 (Spare Parts); Fax: +420 582 360 606

HEAD ASSEMBLY

DET	PART NUMBER	DESCRIPTION	QTY.
01	See Page 3-38	Servomotor ● ●● ●●●	1
02	08.6850.5.000	M5 Washer	7
03	24.6000.6.000	Head	1
04	08.6200.5.008	M5 x 8 Screw	1
05	22.0054.0.000	Upper Thread Guide	1
06	08.6000.8.025	M8 x 25 Screw	2
07	22.0058.0.000	Sewing Head Latch	1
08	07.6045.0.037	3 x 16 Grooved Pin	1
09	07.6440.0.051	Latch Tension Spring	1
10	22.0062.0.000	M4 x 3 Screw	1
11	08.6000.8.040	M8x40 Screw	2
12	12.0008.3.023	Ty-wrap ●●●	1
13	See Page 3-38	Encoder Cable ●● ●●●	1
14	12.5050.2.009	Belt ●●●	1
15	24.0108.0.000	Motor Pulley ●	1
16	01.7806.0.000	Oilite Bushing ●●	2
17	08.6200.4.008	M4x8 Screw	2
18	24.2070.0.000	Optical Senzor Bracket	1
19	24.0069.9.020	Senzor BQ3 Assy ●● ●●●	1
20	22.1422.0.000	Knife Shaft Bushing	1
21	17.0082.8.082	Release Washer	1
22	24.0119.0.050	Large Tension Assembly ●●●	1
23	22.6002.0.000	Head Hinge Assembly	1
24	08.6100.5.020	M5 x 20 Screw	3
25	08.6400.5.005	M5 x 5 Set Screw	2
26	08.6400.5.008	M5x8 Set Screw	2
27	08.6000.6.025	M6 x 25 Screw	2
28	08.6850.6.000	M6 Washer	2
29	24.0106.0.000	Motor Bracket	1
31	08.6700.5.000	Nut M5	4
32	12.1011.0.001	Pin 6 x 20	1
33	08.6100.5.020	Screw M5 x 20	1
35	12.0008.4.197	Clamp ●●●	1
36	01.4980.0.000	Bearing AS 0821	1

Revised 07/2012

e-mail: service@amfreece.cz; parts@amfreece.cz; website: www.amfreece.com

Phone: +420 582 309 286; Fax: +420 582 360 606

BEDPLATE

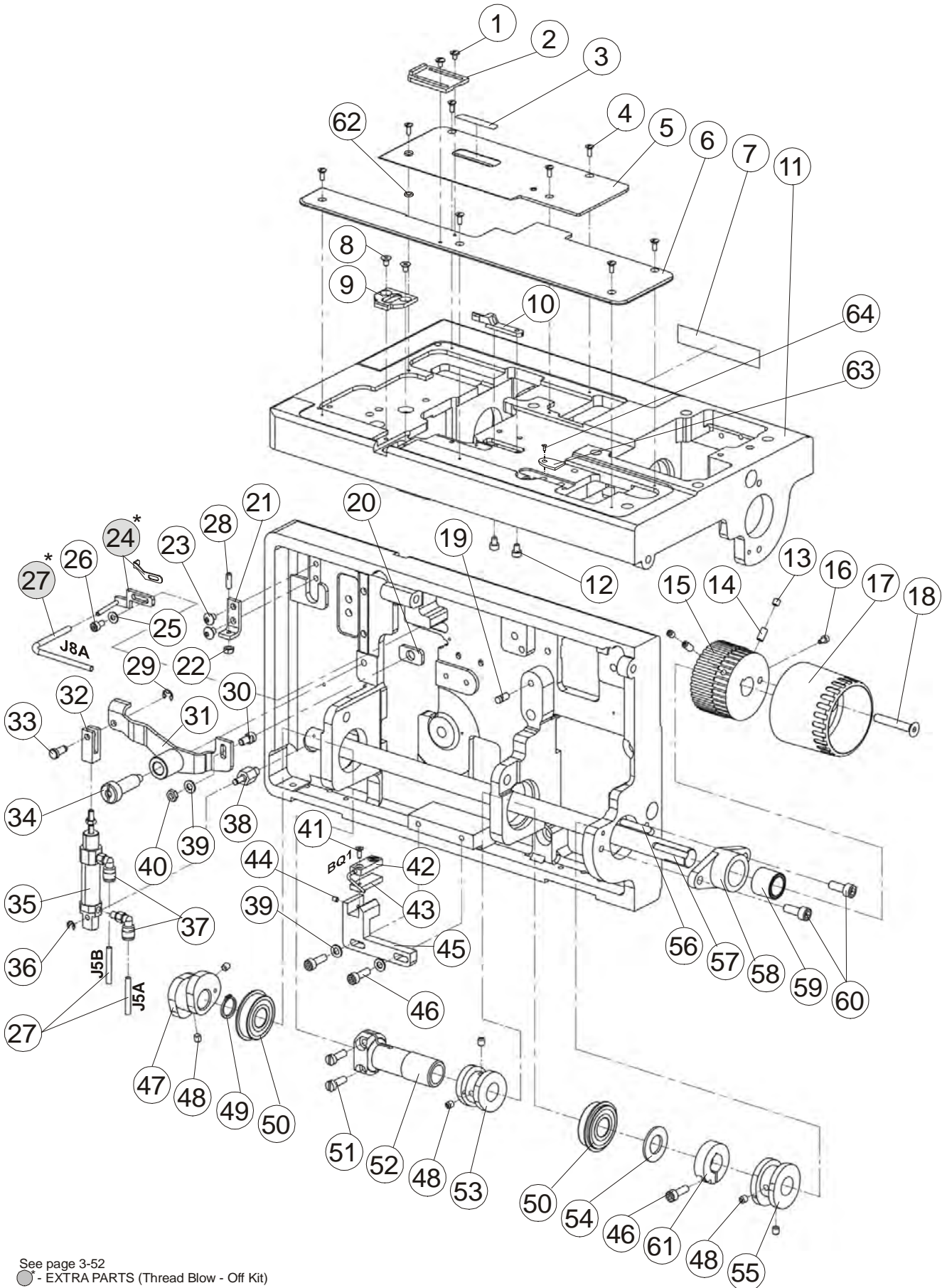

See page 3-52
● - EXTRA PARTS (Thread Blow - Off Kit)

Revised 10/2009

e-mail: service@amfreece.cz; parts@amfreece.cz; website: www.amfreece.com

Phones: +420 582 309 146 (Service), +420 582 309 286 (Spare Parts); Fax: +420 582 360 606

BEDPLATE

DET	PART NUMBER	DESCRIPTION	QTY.
1	22.3068.0.000	Screw	2
2	24.2032.0.000	Material Guide	1
3	12.8000.0.103	Buttonhole Size Sticker	1
4	08.6120.3.008	M3x8 Screw	8
5	24.6102.4.002	Cover Plate Right	1
6	24.6102.4.001	Cover Plate Left	1
7	-	AMF REECE Label - small	1
8	08.6100.4.006	M4x6 Screw	2
9	22.0408.0.000	Trimmer Cover Plate	1
10	24.2066.0.000	Knife Support Block	1
11	24.6100.4.000	Bedplate CAED	1
12	08.6000.4.005	M4x5 Screw	2
13	08.6400.5.005	M5x5 Set Screw	2
14	08.6400.5.010	M5x10 Set Screw	2
15	24.0018.0.000	Main Shaft Drive Pulley	● 1
16	08.6000.3.006	M3x6 Screw	1
17	24.0051.0.066	Hand Wheel	1
18	08.6100.6.035	M6x35 Screw	1
19	07.6045.0.054	5x20 Pin	1
20	22.2631.0.000	Clamp Plate Slidestone	1
21	24.2025.0.000	Slidestone Pivot Screw Bracket	1
22	08.6700.4.000	M4 Nut	1
23	08.6200.5.006	M5x6 Screw	2
24*	24.3318.0.000	Blow-Off Assy.	1
24*	22.3219.0.000	Needle Guard	1
25	08.6850.4.000	M4 Washer	1
26	08.6000.4.005	M4x5 Screw	1
27*	See page 3-52	Air Tubing	●●● -
28	08.6400.4.012	M4x12 Screw	1
29	07.6045.0.042	E-clip	1
30	22.2633.0.000	Slidestone Retainig Screw	1
31	24.2018.0.000	Slidestone Pivot Bracket	1
32	24.2019.0.000	Cylinder Clevis	1
33	24.2020.0.000	Cylinder Clevis Pin	1
34	22.0106.0.000	Hub Shoulder Screw	1
35	See page 3-46	Cylinder	● -
36	07.6045.0.047	E-clip	1
37	See page 3-46	Connector	●●● -
38	24.2017.0.000	Air Cylinder Mounting post	1
39	08.6850.5.000	M5 Flat Washer	3
40	08.6700.5.000	M5 Nut	1
41	08.6100.3.008	M3x8 Screw	1
42	See page 3-38	*Senzor EOC	●●●● -
43	24.0027.0.000	Sensor Mounting Plate	1
44	08.6400.3.004	M3x4 Set Screw	1
45	24.0020.0.000	End Of Cycle Sensor Bracket	1
46	08.6000.5.016	M5x16 Screw	3
47	24.2400.0.000	Looper Cam	1
48	08.6400.5.305	M5x0.5-5 Set Screw	6
49	12.1045.2.001	Retaining Ring	1
50	01.7805.0.000	Shaft Bearing	2
*	- EXTRA PARTS	(Thread Blow - Off Kit)	

Revised 07/2012

e-mail: service@amfreece.cz; parts@amfreece.cz; website: www.amfreece.com

Phone: +420 582 309 286; Fax: +420 582 360 606



BEDPLATE

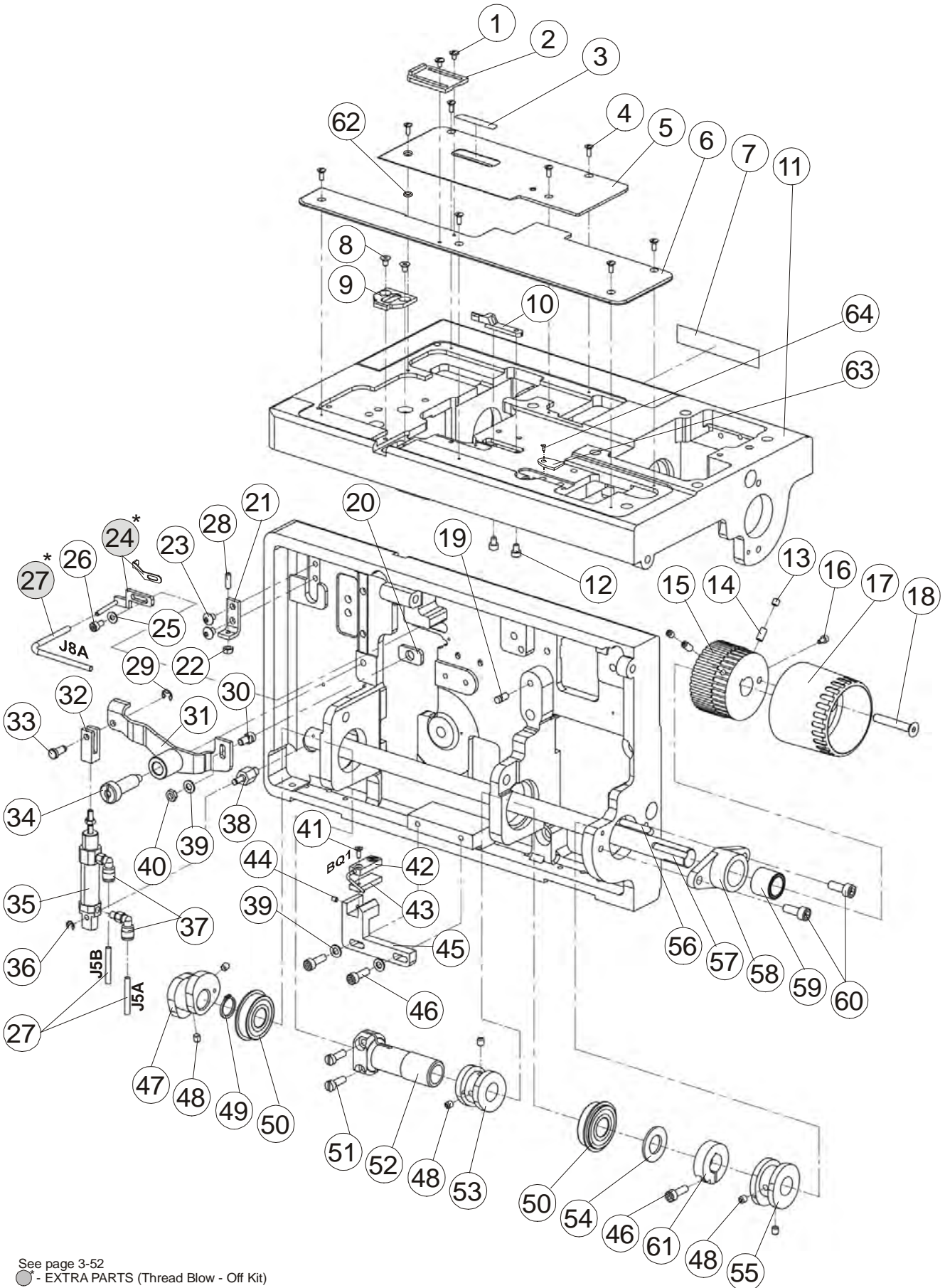

See page 3-52
● - EXTRA PARTS (Thread Blow - Off Kit)

Revised 10/2009

BEDPLATE



DET	PART NUMBER	DESCRIPTION	QTY.
51	22.0153.0.000	Screw	2
52	22.8400.0.000	Shaft Worm Gear	1
53	22.0300.0.000	Feed Cam	1
54	22.0545.0.000	Washer	1
55	22.0006.0.000	Bite Cam	1
56	12.4030.0.002	Key 5x5x30	1
57	24.1000.0.000	Main Shaft	1
58	24.0019.0.000	Bearing Carrier Lower Shaft	1
59	12.2050.0.005	Bearing	1
60	08.6000.6.016	M6x16 Screw	2
61	24.0002.0.000	Clamp Collar	1
62	17.0019.0.228	Washer	1
63	24.2065.0.000	Stop	1
64	22.0143.0.000	Screw	1

--	--	--	--

* - EXTRA PARTS (Thread Blow - Off Kit)

Revised 10/2009

e-mail: service@amfreece.cz; parts@amfreece.cz; website: www.amfreece.com

Phones: +420 582 309 146 (Service), +420 582 309 286 (Spare Parts); Fax: +420 582 360 606

COVERS

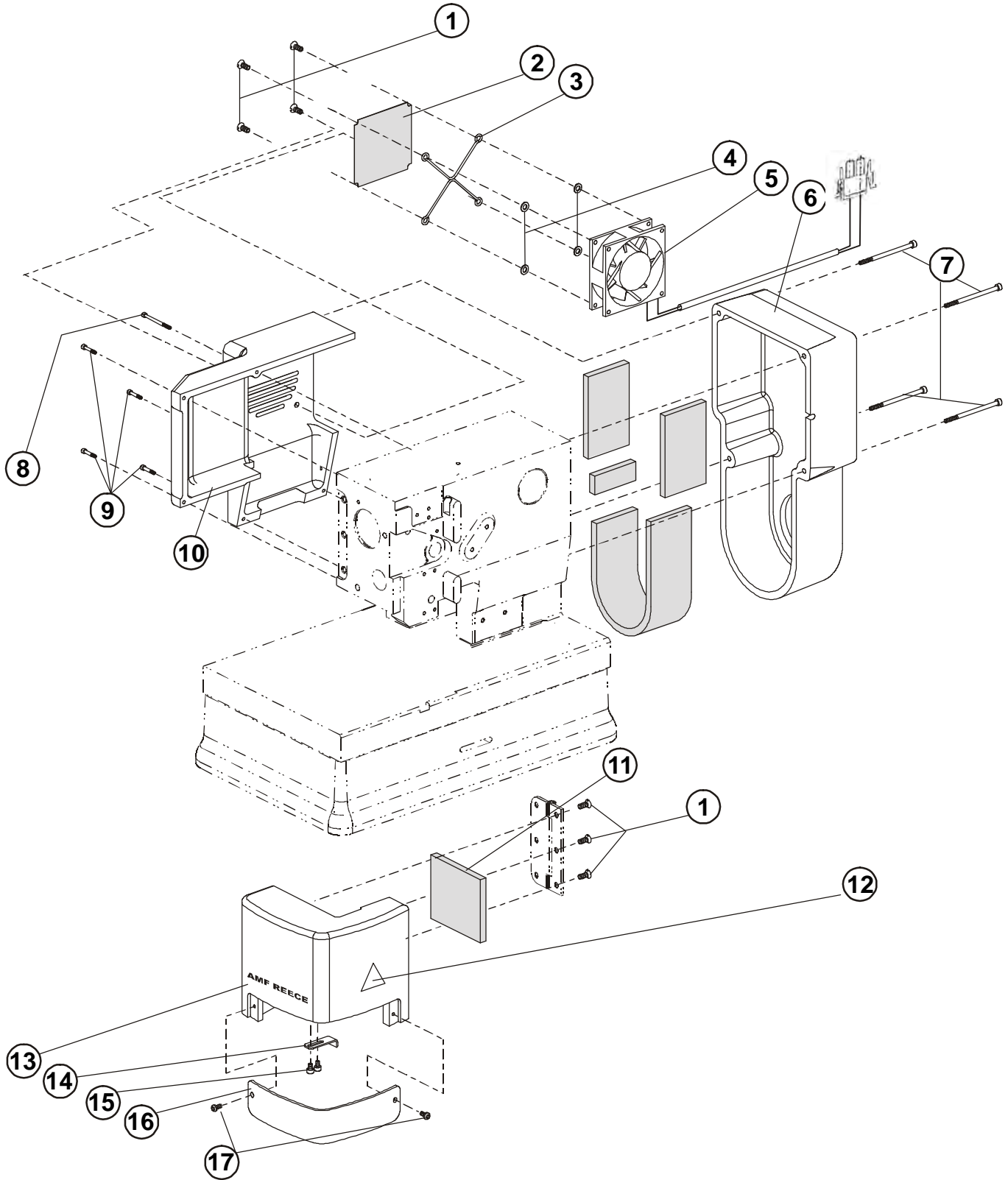

Revised 10/2009

e-mail: service@amfreece.cz; parts@amfreece.cz; website: www.amfreece.com

Phones: +420 582 309 146 (Service), +420 582 309 286 (Spare Parts); Fax: +420 582 360 606

LUBRICATION

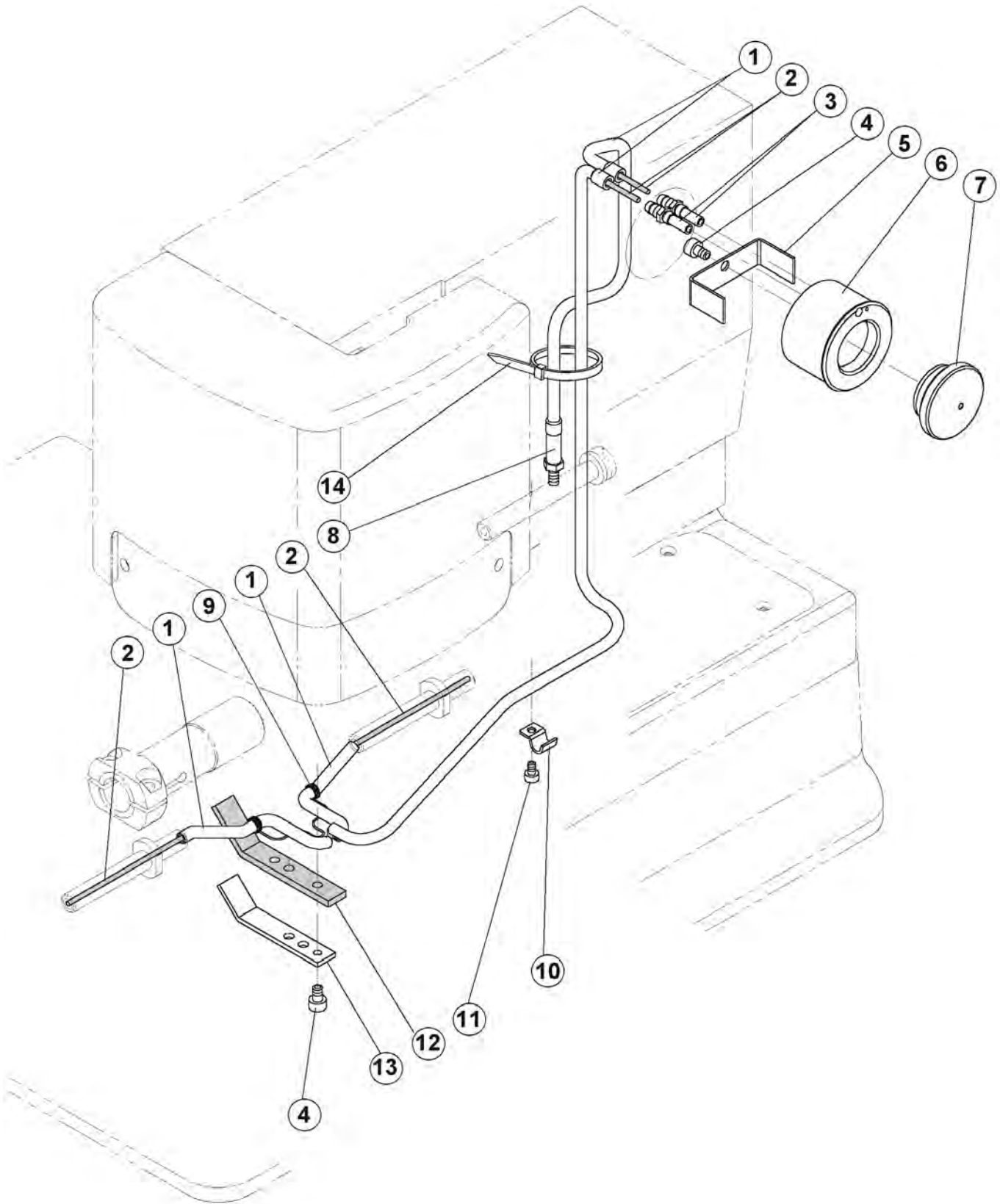

Revised 10/2009

e-mail: service@amfreece.cz; parts@amfreece.cz; website: www.amfreece.com

Phones: +420 582 309 146 (Service), +420 582 309 286 (Spare Parts); Fax: +420 582 360 606

TABLE

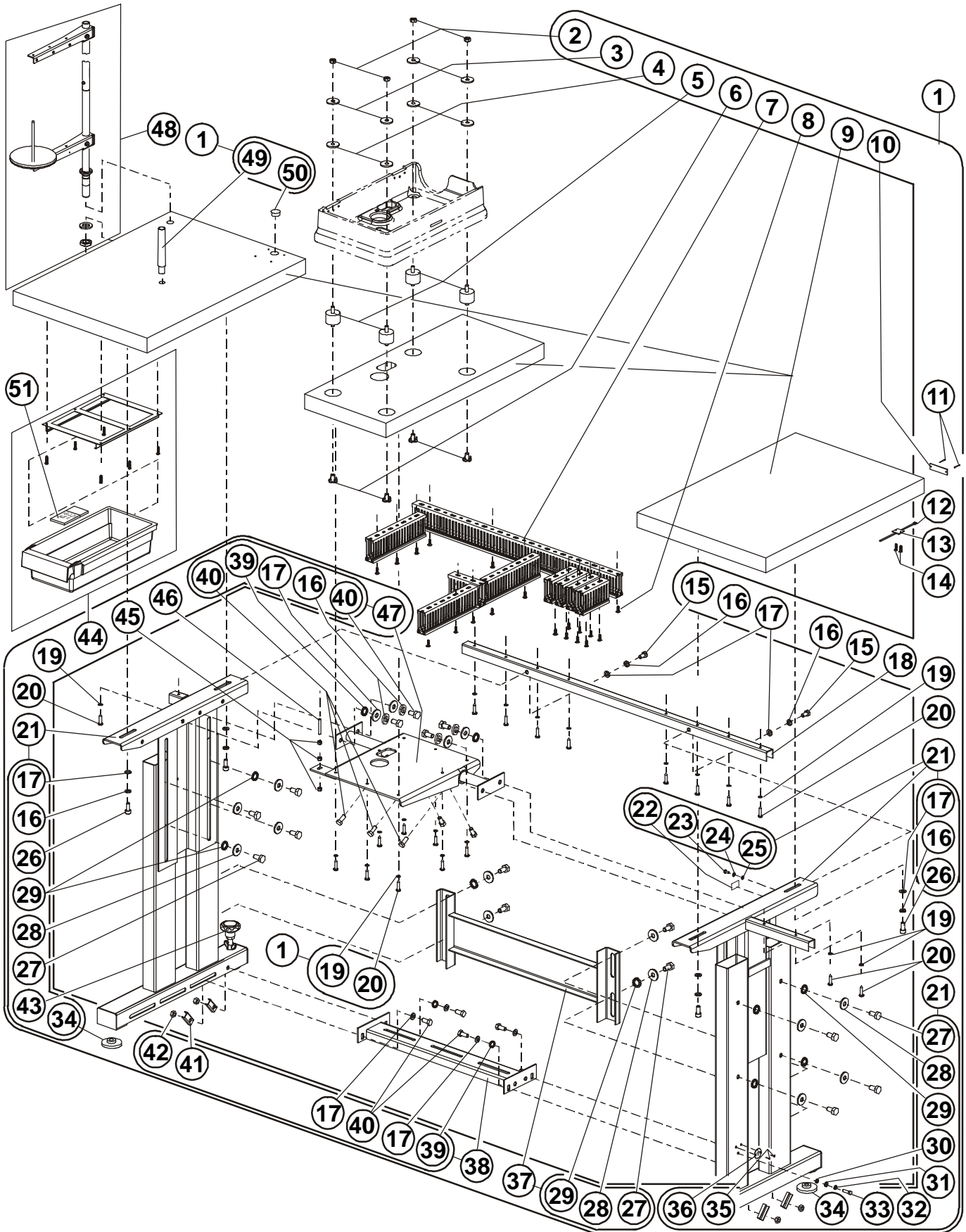

Revised 10/2009

e-mail: service@amfreece.cz; parts@amfreece.cz; website: www.amfreece.com

Phones: +420 582 309 146 (Service), +420 582 309 286 (Spare Parts); Fax: +420 582 360 606

TABLE

DET	PART NUMBER	DESCRIPTION	QTY.
01	04.9024.0.002	Frame Assembly	1
02	08.6700.8.000	Nut M8	(8)
03	17.0019.0.441	Washer	(4)
04	17.0095.1.272	Rubber Washer ●●●	(4)
05	12.0008.6.801	Rubber Spring	(4)
06	12.0008.4.777	Plug	(1)
07	24.0069.9.040	Latch For Kit ●●●	(1)
08	08.6676.3.020	Screw 3,5 x 20	(21)
09	04.9024.0.903	Table ●●●	(1)
10	04.1416.0.003	Label "No. xxxx"	(1)
11	12.1016.1.000	Nail	(2)
12	12.0008.3.023	Ty-wrap ●●●	(1)
13	12.0008.4.058	Clip	(1)
14	08.6652.3.016	Screw 3 x 16	(2)
15			
16	08.6802.8.000	Spring Washer	(4)+((4))
17	08.6852.8.000	Washer	(4)+(4)+((4))
18	04.9024.0.361	Reinforcement Crossbar	(1)
19	08.6852.5.000	Washer M5	(11)
20	08.6663.5.025	Screw 4,8 x 25	(11)
21	04.9024.0.000	Frame Assembly	(1)
22	12.0008.4.052	Label	((1))
23	08.6012.4.010	Screw M4 x 10	((1))
24	08.6852.4.000	Washer 4,3	((1))
25	08.6832.4.000	Lock Washer M4	((1))
26	08.6312.8.025	Screw M8 x 25	((4))
27	08.6312.0.020	Screw M10 x 20	((12))
28	08.6882.0.000	Washer M10	((12))
29	08.6832.0.000	Washer 10,5	((8+2+2))
30	08.6832.6.000	Lock Washer M6	((1))
31	08.6852.6.000	Washer 6,4	((1))
32	08.6802.6.000	Spring Washer	((1))
33	08.6312.6.020	Screw M6 x 20	((1))
34	12.0008.6.813	Rubber Washer ●●●	((3))
35	12.1016.0.000	Drive Screw	((2))
36	17.0081.6.225	Label	((1))
37	04.9000.0.225	Crossbar Rear	(1)
38	04.9000.0.125	Crossbar Down	(1)
39	08.6832.8.000	Lock Washer M8	((2)+(2))
40	08.6312.8.020	Screw	((4)+(4)+(4))
41	12.0008.6.964	Washer - U	((4))
42	08.6702.8.000	Nut M8	(4)
43	12.0008.6.965	Yielding Support	(1)
44	12.0008.6.901	Drawer Kit ●●●	(1)
45	08.6700.6.000	Nut M6	(3)
46	08.6700.6.000	Screw M6 x 40	(1)
47	04.9000.0.325	Crossbar Up Assembly	((1))
48	22.0219.0.000	Thread Stand	1

Revised 10/2009

 e-mail: service@amfreece.cz; parts@amfreece.cz; website: www.amfreece.com

Phones: +420 582 309 146 (Service), +420 582 309 286 (Spare Parts); Fax: +420 582 360 606

ELECTRICAL — I

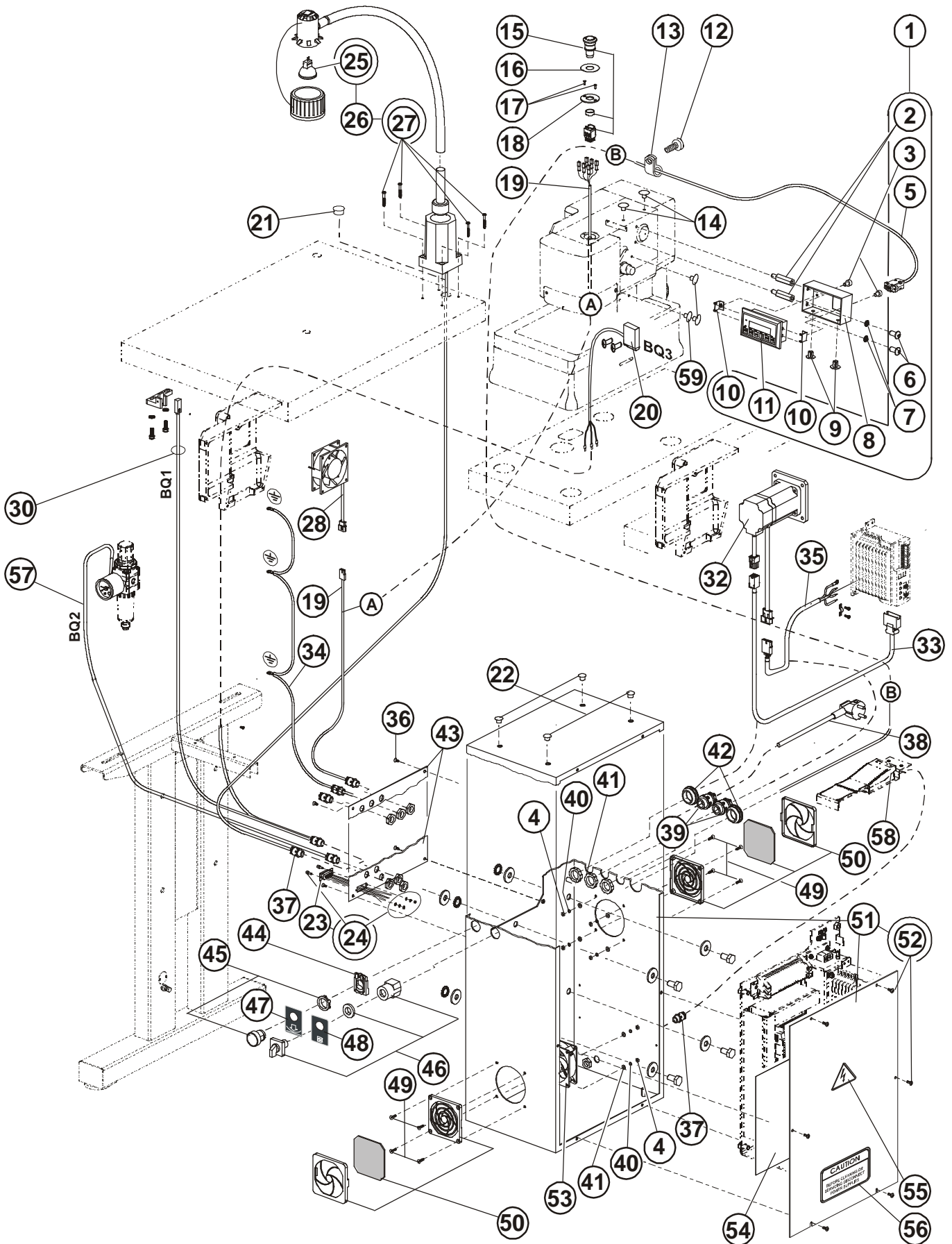

Revised 10/2009

e-mail: service@amfreece.cz; parts@amfreece.cz; website: www.amfreece.com

Phones: +420 582 309 146 (Service), +420 582 309 286 (Spare Parts); Fax: +420 582 360 606

ELECTRICAL — I

DET	PART NUMBER	DESCRIPTION	QTY.
01	03.5524.0.024	Panel Kit Omron	1
02	12.0008.4.565	Screw	(2)
03	08.6000.4.006	Screw	(2)
04	08.6700.4.000	Nut M4	8
05	06.2400.0.003	Cable	(1)
06	08.6200.6.012	Screw	(2)
08	24.0146.0.000	Display Box	(1)
09	12.0008.4.571	Plug	(2)
10	24.0147.0.000	Panel Holder	(2)
11	24.8001.1.002	Display Omron	(1)
12	See Page 3-2	Screw M6x16	
13	12.0010.4.013	Plastic Cable Fitting	1
14	12.0008.4.570	Plug	2
15	12.0008.4.563	Emergency Stop Button	1
16	12.8000.0.047	Label	1
17	08.6102.3.008	Screw	2
19	06.2400.0.012	Emergency Stop Cable	1
20	See Page 3-27	Sensor	1
21	12.0008.4.777	Plug	1
22	12.0008.4.215	Plug	4
23	06.2400.0.702	Cable	1
24	12.0008.4.710	Screw Kit	1
25	12.0008.4.679	Pulb 12V/12W	(1)
26	12.0008.4.403	Halogen Lamp Kit 12V Assembly	1
27		Screw	(4)
28	24.0059.9.069	Fan	1
29			
30	24.0069.9.006	End of Cycle Sensor with Cable	1
31			
32	12.0010.4.177	Servomotor Assembly	1
33	12.0010.4.178	Cable Encoder	1
34		Cable Ground	1
35	12.0010.4.179	Motor Power Cable	1
36	08.6100.4.010	Screw	4
37	12.0008.4.207	Bushing	7
38	12.0008.4.885	Cable	1
18	24.0148.0.000	Emergency Stop Cover	1
39	12.0008.4.231	Bushing	2
40	08.6800.4.000	Washer	4
41	08.6850.4.000	Washer	4
42	12.0008.4.366	Plug PG 29	2
43	24.3325.0.000	Connectors Plate	1
44	12.0008.4.863	Block	1
45	12.0008.4.861	Switch (Black)	1
46	12.0008.4.835	Switch ON - OF	1
47	12.8000.0.041	Label (Clamp Up/Down)	1
48	12.8000.0.040	Label (Main Switch)	1
49	08.6100.4.014	Screw	1
			▶

Revised 10/2009

e-mail: service@amfreece.cz; parts@amfreece.cz; website: www.amfreece.com

Phones: +420 582 309 146 (Service), +420 582 309 286 (Spare Parts); Fax: +420 582 360 606

ELECTRICAL — I

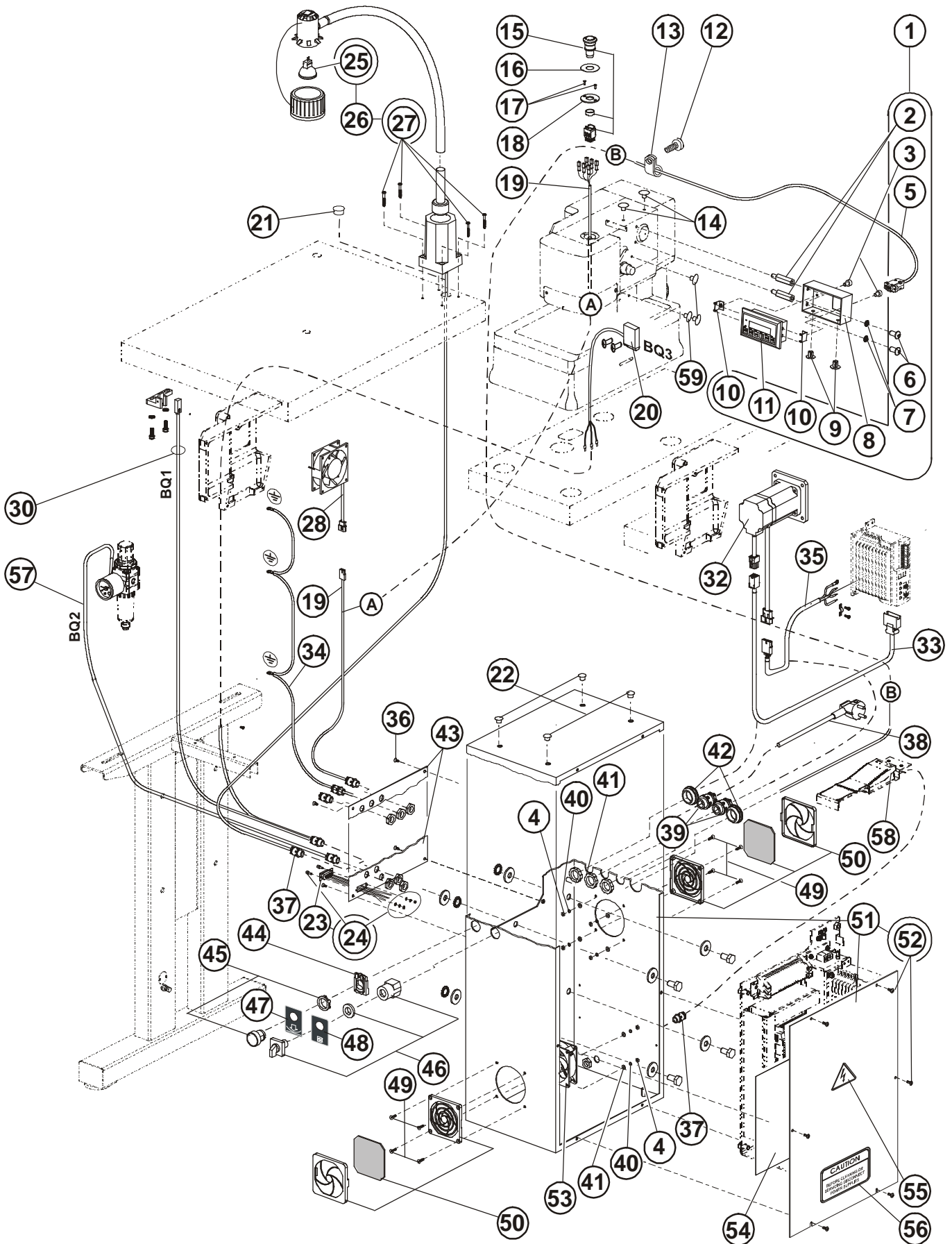

Revised 10/2009

e-mail: service@amfreece.cz; parts@amfreece.cz; website: www.amfreece.com

Phones: +420 582 309 146 (Service), +420 582 309 286 (Spare Parts); Fax: +420 582 360 606

ELECTRICAL — II

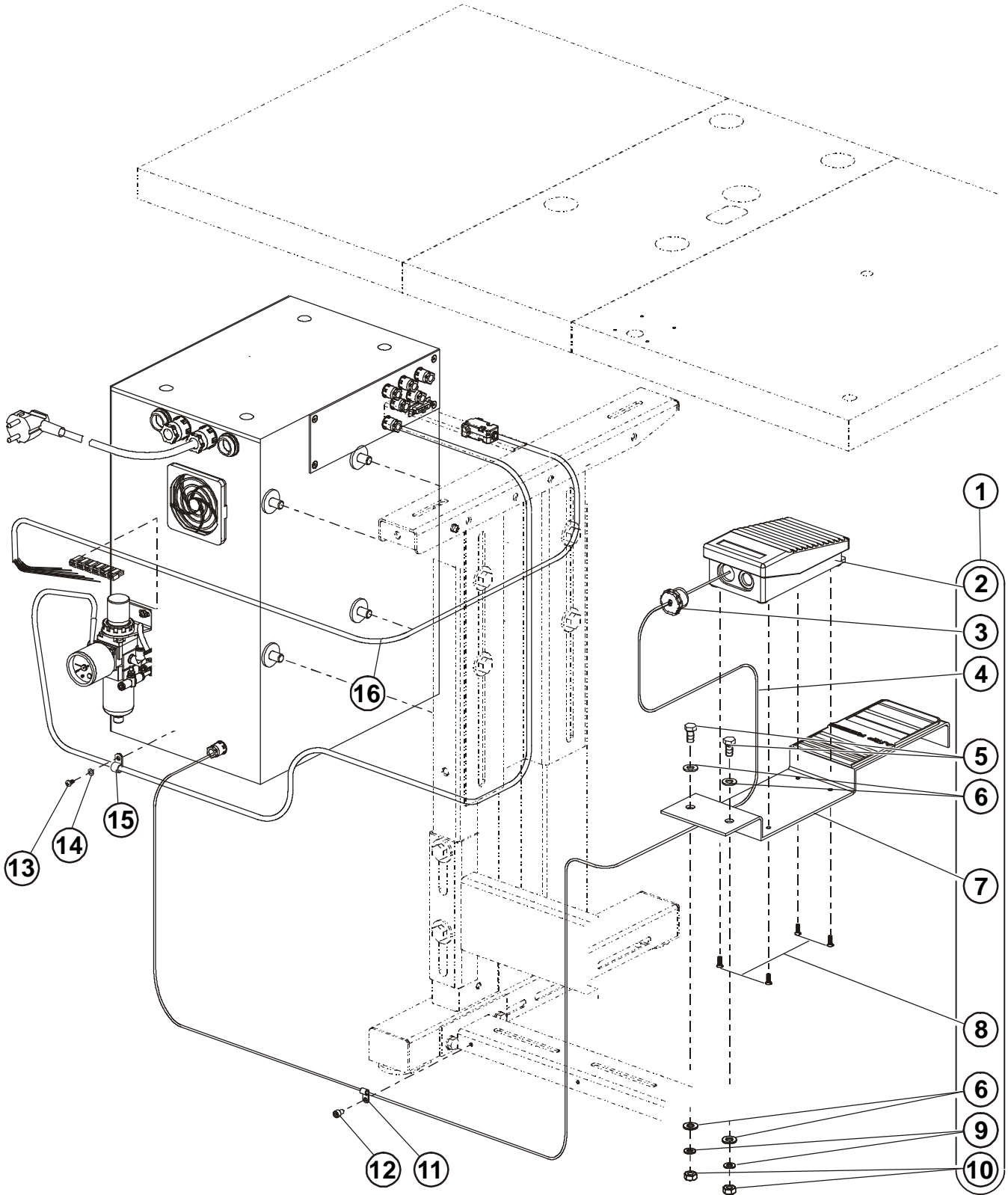

Revised 10/2009

e-mail: service@amfreece.cz; parts@amfreece.cz; website: www.amfreece.com

Phones: +420 582 309 146 (Service), +420 582 309 286 (Spare Parts); Fax: +420 582 360 606

ELECTRICAL — III

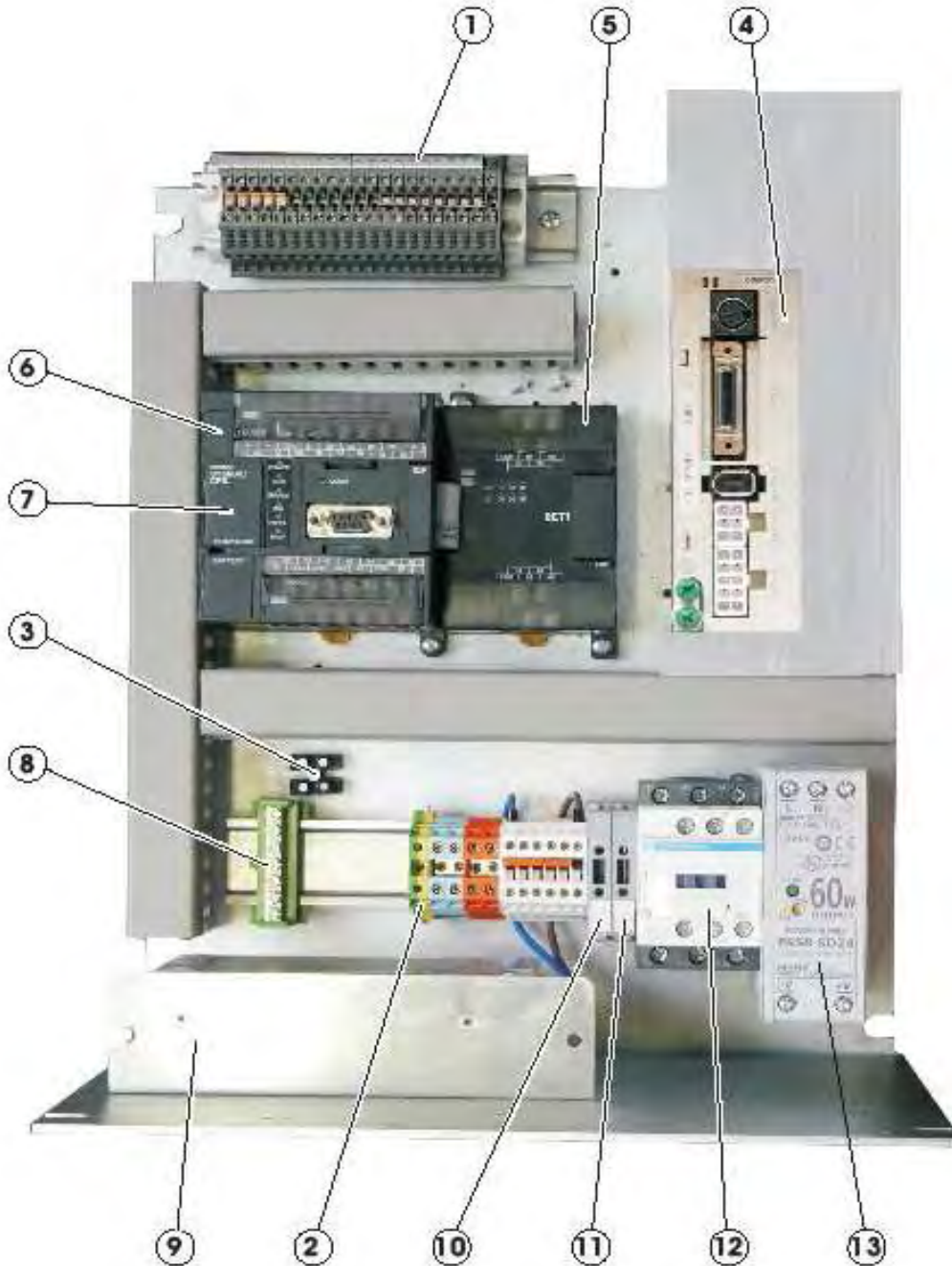

Revised 10/2009

e-mail: service@amfreece.cz; parts@amfreece.cz; website: www.amfreece.com

Phones: +420 582 309 146 (Service), +420 582 309 286 (Spare Parts); Fax: +420 582 360 606

ELECTRICAL — III

DET	PART NUMBER	DESCRIPTION	QTY.
1		Terminal X1	1
2		Terminal X0	1
3		Terminal X12	1
4	24.8001.2.005	Servo (U1)	
5	12.0010.4.071	Extension Block (FX0N)	
6	24.8001.2.001	PLC	1
7	12.0010.4.067	Port RS 232	1
8	12.0008.4.050	Bridge GND	1
9	12.0010.4.078	Filter (Z2)	1
10	12.0008.4.665	Fuse T2A	1
11	12.0008.4.664	Fuse T10A	1
12	12.0008.4.833	Contactactor (KM1)	1
13	12.0010.4.071	Power (GS1)	1

Revised 10/2009

e-mail: service@amfreece.cz; parts@amfreece.cz; website: www.amfreece.com

Phones: +420 582 309 146 (Service), +420 582 309 286 (Spare Parts); Fax: +420 582 360 606

PNEUMATICS

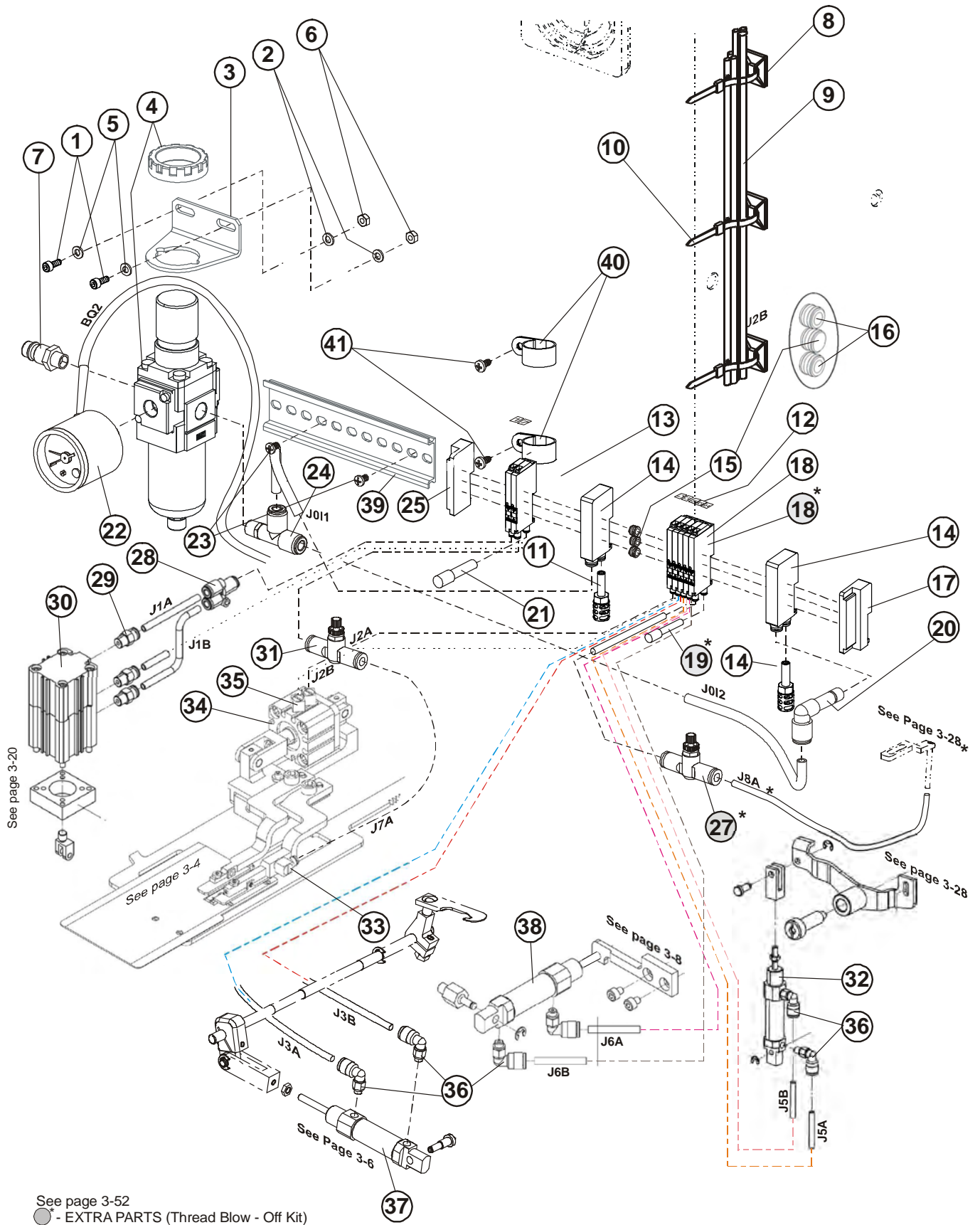

Revised 10/2009

e-mail: service@amfreece.cz; parts@amfreece.cz; website: www.amfreece.com

Phones: +420 582 309 146 (Service), +420 582 309 286 (Spare Parts); Fax: +420 582 360 606

PNEUMATICS

DET	PART NUMBER	DESCRIPTION	QTY.
1	08.6000.5.012	M5x12 Screw	2
2	08.6832.5.000	Washer M5	2
3	12.0008.3.659	Bracket	1
4	12.0008.3.753	Regulator	1
5	08.6850.5.000	Washer M5	2
6	08.6700.5.000	Nut M5	2
7	12.0008.3.420	Connector	1
8	12.0010.4.159	Clip	4
9	24.2061.1.000	Air Tubing - CAED	1
		Air Tubing 6x1 BL JOI1 JOI2 J1A J1B J7A Air Tubing 4x0.75 BL J1A1 = J2A = J3B = J5A = J5B J6A = J6B = J8A	
10	12.0008.3.023	TY-wrap	4
11	12.0008.3.484	Silencer	2
12	12.8000.0.042	Label KIT - CAED	1
13	12.0008.3.852	Valve	2
14	12.0008.3.829	Air Supply Block Assy.	2
15	12.0008.3.839	Blind	2
16	12.0008.3.838	Blind	1
17	12.0008.3.830	Rail Stopper	1
18*	12.0008.3.428	Valve	1
19*	12.0008.3.426	Plug	1
20	12.0008.3.814	Connector	2
21	12.0008.3.437	Plug	1
22	12.0008.3.418	Pressure Gauge	1
23	08.6200.4.006	M4x6 Screw	2
24	12.0008.3.605	Connector	1
25	12.0008.3.831	Rail Stopper	1
26			
27*	12.0008.3.430	Speed Controller	1
28	12.0008.3.449	Connector	1
29	12.0008.3.443	Connector	3
30	12.0008.3.442	Cylinder	1
31	12.0008.3.488	Speed Controller	1
32	12.0008.3.410	Cylinder	1
33	12.0008.3.462	Connector	1
34	12.0008.3.412	Cylinder	1
35	12.0008.3.444	Connector	2
36	12.0008.3.411	Connector	6
37	24.0050.0.000	Cylinder modif.	1
38	24.2072.0.000	Cylinder modif.	1
39	12.0008.3.853	DIN Rail	1
40	12.0008.4.280	Clamp	2
41	08.6683.4.007	Screw	2
*	- EXTRA PARTS (Thread Blow - Off Kit)		

Revised 10/2009

e-mail: service@amfreece.cz; parts@amfreece.cz; website: www.amfreece.com

Phones: +420 582 309 146 (Service), +420 582 309 286 (Spare Parts); Fax: +420 582 360 606

ACCESSORIES

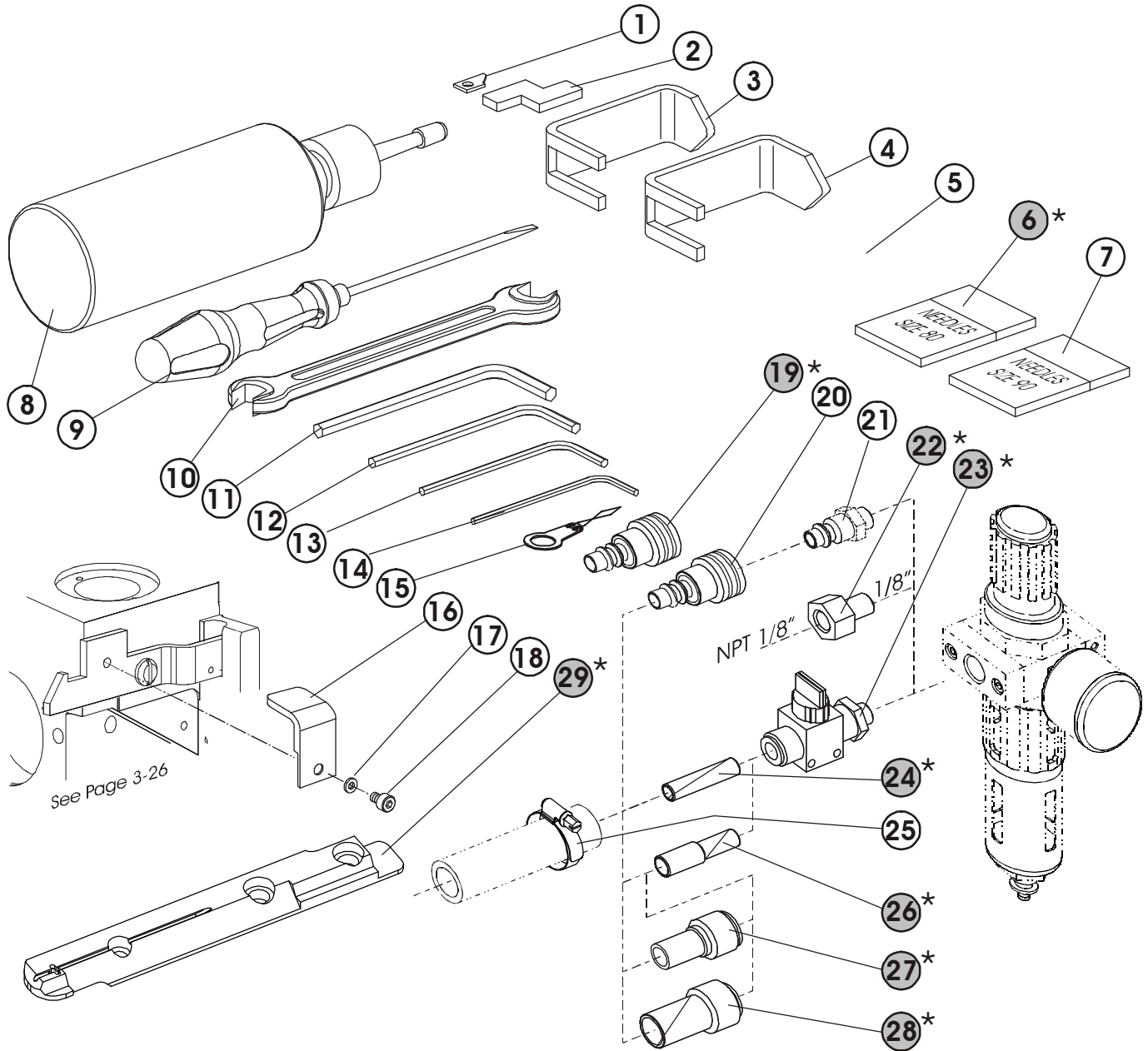

●* — EXTRA PARTS

ACCESSORIES

DET	PART NUMBER	DESCRIPTION	QTY.
01	20.0094.0.000	Trimmer Knife	1
02	22.0209.0.000	Looper Gauge	1
03	24.0030.0.000	Main Shaft Pulley Bracket	1
04	24.0024.0.000	Needle Bar Shaft Pulley Bracket	1
05	02.0750.2.109	Needle, Size 70	10
06*	02.0750.2.100	Needle, Size 80	10
07*	02.0750.2.110	Needles, Size 90	10
08	05.1322.0.000	Oiler ●●●	1
09	12.0008.6.001	Screwdriver	1
10	12.0008.6.109	Wrench	1
11	12.0008.6.102	Allen Key Wrench 4	1
12	12.0008.6.101	Allen Key Wrench 3	1
13	12.0008.6.112	Allen Key Wrench 2-1/2	1
14	12.0008.6.100	Allen Key Wrench 2	1
15	12.0008.6.105	Needle Threader	1
16	22.0213.0.000	Bracket	1
17	08.6850.4.000	M4 Washer	1
18	08.6000.4.005	M4 x 5 Screw	1
19*	12.0008.3.607	Connector Dia 8	1
20	12.0008.3.608	Connector Dia 10	1
21	See page 3-46	Connector	—
22*	12.0008.3.081	Pneumatic Adapter (1/8" / NPT 1/8")	1
23*	12.0008.3.463	Handvalve	1
24*	12.0008.3.464	Connector	1
25	12.0008.3.251	Air Tubing Clamp	1
26*	12.0008.3.466	Connector	1
27*	12.0008.3.467	Connector	1
28*	12.0008.3.465	Connector	1
29*	24.2075.4.000	Throat Plate	1

* — EXTRA PARTS

Revised 10/2009

e-mail: service@amfreece.cz; parts@amfreece.cz; website: www.amfreece.com

Phones: +420 582 309 146 (Service), +420 582 309 286 (Spare Parts); Fax: +420 582 360 606

EXTRA PARTS

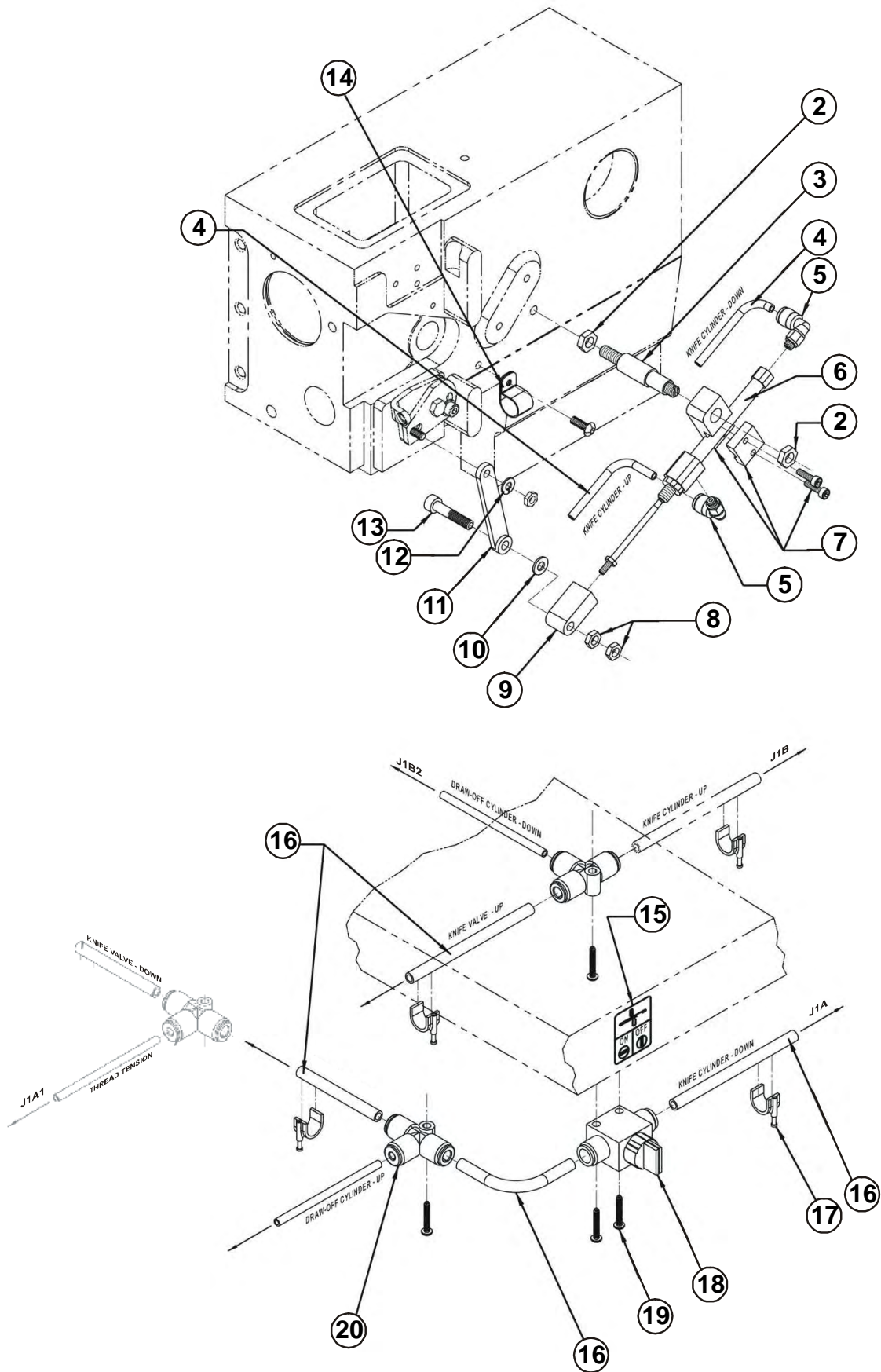

Revised 10/2009

e-mail: service@amfreece.cz; parts@amfreece.cz; website: www.amfreece.com

Phones: +420 582 309 146 (Service), +420 582 309 286 (Spare Parts); Fax: +420 582 360 606

EXTRA PARTS

DET	PART NUMBER	DESCRIPTION	QTY.
1	03.5524.0.004	CAED Thread-draw Off KIT	1
2	08.6700.6.000	Nut M6	(1)
3	24.4053.0.000	Stud	(1)
4	15.0008.3.416	Air Tubing	-
5	12.0008.3.411	Connector	(2)
6	12.0008.3.727	Cylinder	(1)
7	24.4052.0.000	Cylinder Holder	(1)
8	08.6700.5.000	Nut M5	(2)
9	24.4054.0.000	Knuckle	(1)
10	08.6850.5.000	Washer 5,3	(1)
11	24.4055.0.000	Rod Tension	(1)
12	08.6800.4.000	Washer 4,1	(1)
13	08.6000.5.025	Screw M5-25	(1)
14	12.0008.4.253	Clamp	(1)
15	12.8000.0.029	Label On/Off	(1)
16	12.0008.3.415	Air Tubing	-
17	12.0008.4.227	Cable Clamp	(4)
18	12.0008.3.611	Finger Valve	(1)
19	08.6662.3.025	Screw	(4)
20	12.0008.3.461	Connector	(2)

EXTRA PARTS

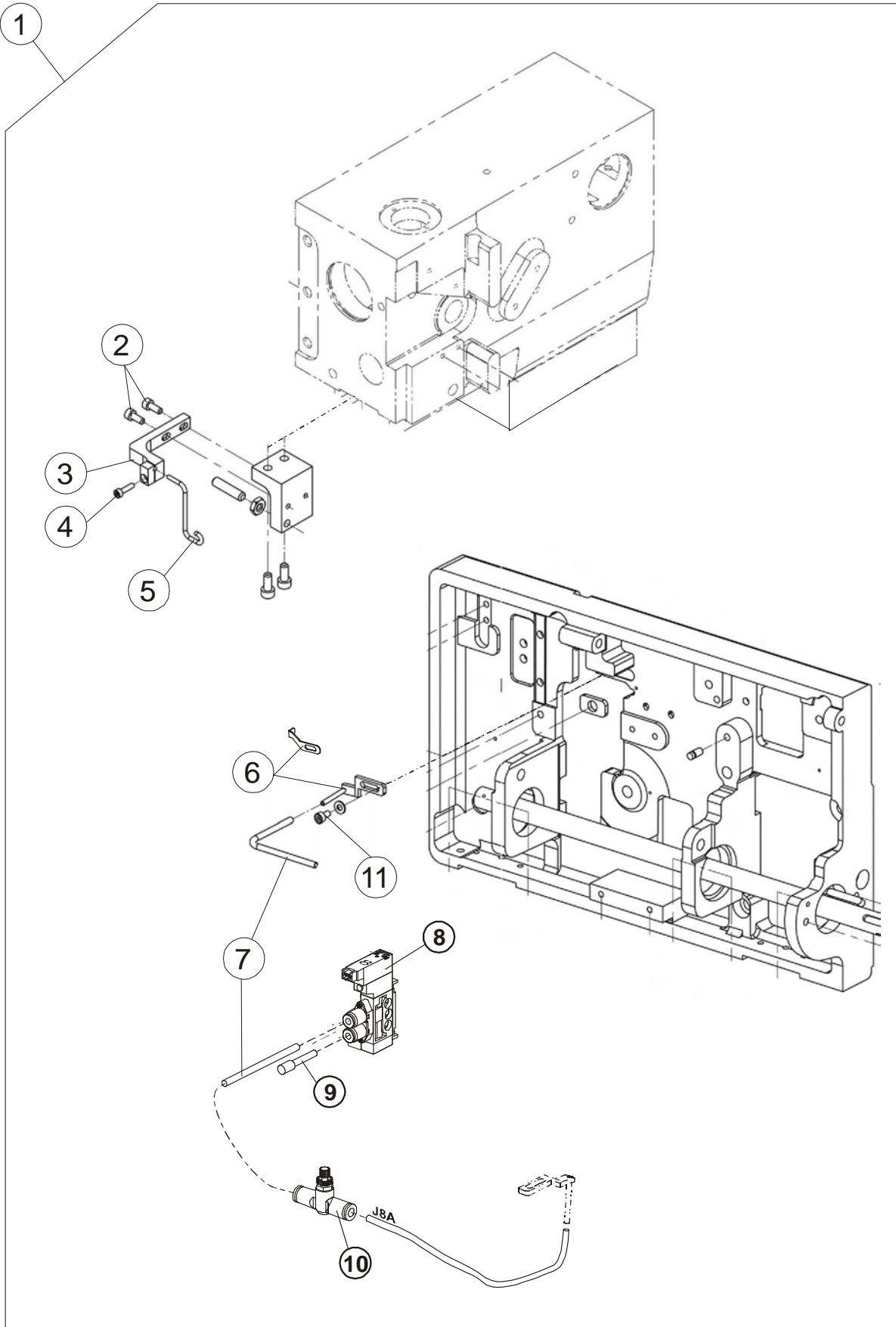

Revised 10/2009

INDEX

PART NUMBER	PAGE	DET	QTY	PART NUMBER	PAGE	DET	QTY	PART NUMBER	PAGE	DET	QTY
00.2751.3.602				07.6045.0.042	3-7	09	1	08.6000.4.014	3-19	08	2
00.2751.3.602	3-41	56	1	07.6045.0.042	3-29	29	1	08.6000.4.016	3-9	21	4
01.1382.0.000	3-15	06	1	07.6045.0.046	3-5	21	2	08.6000.4.025	3-11	32	2
01.1397.0.000	3-15	11	4	07.6045.0.047	3-9	16	1	08.6000.4.070	3-33	07	4
01.2084.0.000	3-5	31	2	07.6045.0.047	3-29	36	1				
01.2193.0.000	3-3	02	1	07.6045.0.054	3-29	19	1	08.6000.5.008			
01.2376.0.000	3-5	35	6	07.6321.0.001	3-25	11	1	08.6000.5.008	3-43	12	1
01.2386.0.000	3-7	03	1	07.6321.0.025	3-11	50	2	08.6000.5.010	3-5	22	1
01.4980.0.000	3-27	36	1	07.6321.0.025	3-19	16	2	08.6000.5.012	3-21	40	4
01.6551.0.000	3-3	07	1	07.6321.0.029	3-19	13	(2)	08.6000.5.012	3-47	01	2
01.6551.0.000	3-21	10	3	07.6321.0.030	3-13	61	(1).	08.6000.5.016	3-3	37	1
01.7447.1.000	3-3	05	1	07.6440.0.018	3-11	41	2	08.6000.5.016	3-21	20	4
01.7447.1.000	3-21	11	3	07.6440.0.028	3-11	23	2	08.6000.5.016	3-29	46	3
01.7804.0.000	3-3	18	1	07.6440.0.028	3-19	18	2	08.6000.5.020	3-11	15	2
01.7805.0.000	3-3	23	1	07.6440.0.033	3-11	08	2	08.6000.5.020	3-21	33	2
01.7805.0.000	3-29	50	2	07.6440.0.036	3-15	21	3	08.6000.5.022	3-5	25	4
01.7806.0.000	3-27	16	2	07.6440.0.037	3-25	04	2	08.6000.5.025	3-51	13	(1)
01.7809.0.000	3-3	17	1	07.6440.0.040	3-9	10	1	08.6000.6.010	3-21	23	2
				07.6440.0.041	3-11	11	1	08.6000.6.012	3-5	01	2
02.0750.2.100				07.6440.0.045	3-25	27	1	08.6000.6.016	3-3	22	2
02.0750.2.100	3-49	06*	10	07.6440.0.050	3-11	18	1	08.6000.6.016	3-31	60	2
02.0750.2.109	3-3	32	1	07.6440.0.051	3-27	09	1	08.6000.6.025	3-19	01	1
02.0750.2.109	3-49	05	10					08.6000.6.025	3-27	27	2
02.0750.2.110	3-49	07*	10	08.6000.3.006				08.6000.6.030	3-3	15	(1)
03.5524.0.004	3-51	01	1	08.6000.3.006	3-29	16	1	08.6000.8.025	3-27	06	2
03.5524.0.024	3-39	01	1	08.6000.3.006	3-35	11	1	08.6000.8.040	3-27	11	2
03.5524.0.029	3-53	01		08.6000.3.010	3-11	38	1	08.6012.4.010	3-17	11	1
				08.6000.3.010	3-15	17	1	08.6012.4.010	3-37	23	((1))
				08.6000.3.010	3-19	06	1	08.6032.4.010	3-41	52	(6)
04.1416.0.003				08.6000.3.012	3-21	48*	1				
04.1416.0.003	3-37	10	(1)	08.6000.3.012	3-53	04	(1)	08.6100.3.008			
04.9000.0.125	3-37	38	(1)	08.6000.3.016	3-33	09	4	08.6100.3.008	3-19	05	2
04.9000.0.225	3-37	37	(1)	08.6000.3.040	3-33	08	1	08.6100.3.008	3-29	41	1
04.9000.0.325	3-37	47	((1))	08.6000.4.005	3-9	07	6	08.6100.3.030	3-11	01	2
04.9024.0.002	3-37	01	1	08.6000.4.005	3-13	58	2	08.6100.4.006	3-9	01	1
04.9024.0.002	3-37	21	(1)	08.6000.4.005	3-21	28	1	08.6100.4.006	3-29	08	2
04.9024.0.361	3-37	18	(1)	08.6000.4.005	3-29	12	2	08.6100.4.010	3-39	36	4
04.9024.0.500	3-41	51	1	08.6000.4.005	3-29	26	1	08.6100.4.012	3-43	08	(4)
04.9024.0.903	3-37	09	(1)	08.6000.4.005	3-49	18	1	08.6100.4.014	3-21	08	2
05.1322.0.000	3-49	08	1	08.6000.4.006	3-21	18	1	08.6100.4.014	3-39	49	1
				08.6000.4.006	3-33	15	2	08.6100.5.010	3-25	09	1
06.2400.0.003				08.6000.4.006	3-35	04	2	08.6100.5.012	3-5	38	2
06.2400.0.003	3-39	05	(1)	08.6000.4.006	3-39	03	(2)	08.6100.5.012	3-17	02	5
06.2400.0.012	3-39	19	1	08.6000.4.008	3-53	11	(1)	08.6100.5.016	3-21	21	8
06.2400.0.702	3-39	23	1	08.6000.4.010	3-9	24	2	08.6100.5.016	3-33	01	7
06.8800.0.001	3-43	02	(1)	08.6000.4.010	3-21	38*	4	08.6100.5.020	3-15	04	2
				08.6000.4.010	3-53	02	(2)	08.6100.5.020	3-17	07	1
07.6045.0.009				08.6000.4.012	3-7	07	1	08.6100.5.020	3-27	24	3
07.6045.0.009	3-11	19	2	08.6000.4.014	3-11	45	2	08.6100.5.020	3-27	33	1
07.6045.0.034	3-11	30	1	08.6000.4.014	3-15	25	2	08.6100.6.035	3-29	18	1
07.6045.0.037	3-11	16	2								

Revised 01/2010

e-mail: service@amfreece.cz; parts@amfreece.cz; website: www.amfreece.com

Phones: +420 582 309 146 (Service), +420 582 309 286 (Spare Parts); Fax: +420 582 360 606

INDEX

PART NUMBER	PAGE	DET	QTY	PART NUMBER	PAGE	DET	QTY	PART NUMBER	PAGE	DET	QTY
08.6102.3.008	3-39	17	2	08.6400.5.305	3-29	48	6	08.6832.5.000	3-47	02	2
08.6120.3.008	3-29	04	8	08.6490.6.025	3-23	51	1	08.6832.6.000	3-37	30	((1))
08.6200.3.008				08.6652.3.016				08.6832.8.000	3-37	39	((2)+(2))
08.6200.3.008	3-5	03	2	08.6652.3.016	3-37	14	(2)	08.6850.4.000	3-7	13	1
08.6200.4.006	3-47	23	2	08.6662.3.025	3-51	19	(4)	08.6850.4.000	3-21	17	4
08.6200.4.008	3-23	54	1	08.6663.5.025	3-37	20	(11)	08.6850.4.000	3-29	25	1
08.6200.4.008	3-23	54	1	08.6676.3.020	3-37	08	(21)	08.6850.4.000	3-39	41	4
08.6200.4.008	3-27	17	2	08.6683.4.007	3-43	13	1	08.6850.4.000	3-49	17	1
08.6200.4.008	3-33	17	2	08.6683.4.007	3-47	41	2	08.6850.5.000	3-21	42	1
08.6200.5.006	3-21	43	1	08.6700.4.000				08.6850.5.000	3-27	02	7
08.6200.5.006	3-29	23	2	08.6700.4.000	3-5	20	1	08.6850.5.000	3-29	39	3
08.6200.5.008	3-27	04	1	08.6700.4.000	3-7	11	1	08.6850.5.000	3-33	04	4
08.6200.5.012	3-17	03	6	08.6700.4.000	3-21	19	1	08.6850.5.000	3-47	05	2
08.6200.5.020	3-17	16	1	08.6700.4.000	3-29	22	1	08.6850.5.000	3-51	10	(1)
08.6200.6.012	3-39	06	(2)	08.6700.4.000	3-39	04	8	08.6850.6.000	3-27	28	2
08.6200.6.025	3-3	31	1	08.6700.5.000	3-17	09	2	08.6850.8.000	3-13	56	1
08.6310.4.014				08.6700.5.000	3-19	24	2	08.6850.8.000	3-15	32	1
08.6310.4.014	3-21	46	1	08.6700.5.000	3-27	31	4	08.6852.4.000	3-37	24	((1))
08.6312.0.020	3-37	27	((12))	08.6700.5.000	3-29	40	1	08.6852.4.000	3-43	14	1
08.6312.6.020	3-37	33	((1))	08.6700.5.000	3-47	06	2	08.6852.5.000	3-37	19	(11)
08.6312.8.020	3-37	40	((4)+(4)+(4))	08.6700.5.000	3-51	08	(2)	08.6852.6.000	3-37	31	((1))
08.6312.8.020	3-43	05	(2)	08.6700.6.000	3-37	45	(3)	08.6852.8.000	3-37	17	4)+(4)+(4)
08.6312.8.025	3-37	26	((4))	08.6700.6.000	3-37	46	(1)	08.6852.8.000	3-43	06	(4)
08.6400.3.004				08.6700.6.000	3-51	02	(1)	08.6882.0.000	3-37	28	((12))
08.6400.3.004	3-5	10	1	08.6700.8.000	3-13	57	1	08.6887.5.000	3-9	09	1
08.6400.3.004	3-29	44	1	08.6700.8.000	3-15	33	1	12.0008.3.023			
08.6400.3.005	3-3	12	4	08.6700.8.000	3-37	02	(8)	12.0008.3.023	3-17	18	2
08.6400.3.006	3-5	06	1	08.6702.8.000	3-37	42	(4)	12.0008.3.023	3-27	12	1
08.6400.3.010	3-5	11	1	08.6702.8.000	3-43	10	(2)	12.0008.3.023	3-35	14	1
08.6400.4.004	3-3	21	2 (2)	08.6710.3.000	3-5	05	2	12.0008.3.023	3-37	12	(1)
08.6400.4.004	3-5	18	2	08.6710.4.000	3-9	12	1	12.0008.3.023	3-47	10	4
08.6400.4.004	3-15	01	2	08.6710.5.000	3-9	12	1	12.0008.3.081	3-49	22*	1
08.6400.4.004	3-19	27	1	08.6710.5.000	3-13	52	2	12.0008.3.251	3-49	25	1
08.6400.4.004	3-21	26	2	08.6710.5.000	3-15	23	2	12.0008.3.410			
08.6400.4.005	3-9	04	1	08.6710.6.000	3-23	52	1	12.0008.3.410	3-47	32	1
08.6400.4.005	3-11	28	6	08.6710.6.000	3-23	52	1	12.0008.3.411	3-47	36	6
08.6400.4.005	3-19	20	1	08.6733.3.000	3-11	24	2	12.0008.3.411	3-51	05	(2)
08.6400.4.012	3-5	19	1	08.6800.4.000				12.0008.3.412	3-47	34	1
08.6400.4.012	3-29	28	1	08.6800.4.000	3-11	43	2	12.0008.3.415	3-47	34	1
08.6400.5.005	3-3	04	1	08.6800.4.000	3-15	26	2	12.0008.3.415	3-51	16	-
08.6400.5.005	3-11	33	1	08.6800.4.000	3-39	40	4	12.0008.3.416	3-53	07	(2m)
08.6400.5.005	3-27	25	2	08.6800.4.000	3-51	12	(1)	12.0008.3.418	3-47	22	1
08.6400.5.005	3-29	13	2	08.6802.6.000	3-37	32	((1))	12.0008.3.420	3-47	07	1
08.6400.5.008	3-5	33	1	08.6802.8.000	3-37	16	(4)+(4)	12.0008.3.426	3-47	19*	1
08.6400.5.008	3-27	26	2	08.6802.8.000	3-43	09	(2)	12.0008.3.426	3-53	09	(1)
08.6400.5.010	3-29	14	2	08.6832.0.000	3-37	29	((8+2+2))	12.0008.3.428	3-47	18*	1
08.6400.5.305	3-11	13	4	08.6832.4.000	3-17	12	1	12.0008.3.430	3-47	27*	1
				08.6832.4.000	3-37	25	((1))	12.0008.3.431	3-53	10	(2)
								12.0008.3.437	3-47	21	1

Revised 01/2010

e-mail: service@amfreece.cz; parts@amfreece.cz; website: www.amfreece.com

Phones: +420 582 309 146 (Service), +420 582 309 286 (Spare Parts); Fax: +420 582 360 606

INDEX

PART NUMBER	PAGE	DET	QTY	PART NUMBER	PAGE	DET	QTY	PART NUMBER	PAGE	DET	QTY
12.0008.3.442	3-47	30	1	12.0008.4.280	3-43	15	1	12.0010.4.179	3-39	35	1
12.0008.3.443	3-47	29	3	12.0008.4.280	3-47	40	2	12.1011.0.001	3-27	32	1
12.0008.3.444	3-47	35	2	12.0008.4.296	3-43	03	(1)	12.1016.0.000	3-37	35	((2))
12.0008.3.449	3-47	28	1	12.0008.4.306	3-43	04	(1)	12.1016.1.000	3-37	11	(2)
12.0008.3.461	3-51	20	(2)	12.0008.4.366	3-39	42	2	12.1045.2.001	3-3	29	1
12.0008.3.462	3-47	33	1	12.0008.4.403	3-39	26	1	12.1045.2.001	3-29	49	1
12.0008.3.463	3-49	23*	1	12.0008.4.472	3-41	50	2	12.1045.3.001	3-7	04	1
12.0008.3.464	3-49	24*	1	12.0008.4.477	3-5	30	(1)	12.2010.1.002	3-15	14	2
12.0008.3.465	3-49	28*	1	12.0008.4.563	3-39	15	1	12.2050.0.003	3-3	20	1
12.0008.3.466	3-49	26*	1	12.0008.4.565	3-39	02	(2)	12.2050.0.005	3-31	59	1
12.0008.3.467	3-49	27*	1	12.0008.4.570	3-39	14	2	12.4030.0.002	3-31	56	1
12.0008.3.484	3-47	11	2	12.0008.4.571	3-39	09	(2)	12.5050.2.009	3-27	14	1
12.0008.3.488	3-47	31	1	12.0008.4.664	3-45	11	1	12.8000.0.029	3-51	15	(1)
				12.0008.4.665	3-45	10	1	12.8000.0.040	3-39	48	1
12.0008.3.605				12.0008.4.679	3-39	25	(1)	12.8000.0.041	3-39	47	1
12.0008.3.605	3-47	24	1	12.0008.4.710	3-39	24	1	12.8000.0.042	3-47	12	1
12.0008.3.607	3-49	19*	1	12.0008.4.777	3-37	06	(1)	12.8000.0.047	3-39	16	1
12.0008.3.608	3-49	20	1	12.0008.4.777	3-39	21	1	12.8000.0.103	3-29	03	1
12.0008.3.611	3-51	18	(1)	12.0008.4.833	3-45	12	1	12.8000.0.147	3-41	54	1
12.0008.3.659	3-47	03	1	12.0008.4.835	3-39	46	1	12.8000.1.028	3-17	06	1
12.0008.3.727	3-51	06	(1)	12.0008.4.861	3-39	45	1	15.0008.3.416	3-51	04	-
12.0008.3.753	3-47	04	1	12.0008.4.863	3-39	44	1				
12.0008.3.814	3-47	20	2	12.0008.4.885	3-39	38	1	17.0019.0.228			
12.0008.3.828	3-53	08	(4)					17.0019.0.228	3-31	62	1
12.0008.3.829	3-47	14	2	12.0008.6.001				17.0019.0.441	3-37	03	(4)
12.0008.3.830	3-47	17	1	12.0008.6.001	3-49	09	1	17.0019.0.517	3-11	37	1
12.0008.3.831	3-47	25	1	12.0008.6.100	3-49	14	1	17.0019.2.057	3-11	25	1
12.0008.3.838	3-47	16	1	12.0008.6.101	3-49	12	1	17.0026.2.077	3-3	34	1
12.0008.3.839	3-47	15	2	12.0008.6.102	3-49	11	1	17.0027.1.799	3-35	09	1
12.0008.3.852	3-47	13	2	12.0008.6.105	3-49	15	1	17.0081.6.225	3-37	36	((1))
12.0008.3.853	3-47	39	1	12.0008.6.109	3-49	10	1	17.0082.6.000	3-35	10	1
12.0008.3.854	3-43	16	1	12.0008.6.112	3-49	13	1	17.0082.8.017	3-3	35	2
				12.0008.6.800	3-19	23	1	17.0082.8.082	3-27	21	1
12.0008.4.050				12.0008.6.801	3-37	05	(4)	17.0094.5.310	3-35	12	1
12.0008.4.050	3-45	08	1	12.0008.6.813	3-37	34	((3))	17.0095.1.272	3-37	04	(4)
12.0008.4.052	3-17	10	1	12.0008.6.901	3-37	44	(1)	17.0095.1.329	3-35	07	1
12.0008.4.052	3-37	22	((1))	12.0008.6.964	3-37	41	((4))				
12.0008.4.058	3-17	19	1	12.0008.6.965	3-37	43	(1)	20.0092.0.004			
12.0008.4.058	3-37	13	(1)					20.0092.0.004	3-7	02	1
12.0008.4.155	3-41	55	1	12.0010.4.013				20.0093.2.004	3-7	01	1
12.0008.4.197	3-17	08	1	12.0010.4.013	3-17	17	1	20.0094.0.000	3-15	07	1
12.0008.4.197	3-27	35	1	12.0010.4.013	3-39	13	1	20.0094.0.000	3-49	01	1
12.0008.4.207	3-39	37	7	12.0010.4.067	3-45	07	1	20.0094.0.000	3-49	01	1
12.0008.4.215	3-39	22	4	12.0010.4.071	3-45	05		20.0111.0.000	3-15	08	1
12.0008.4.227	3-51	17	(4)	12.0010.4.071	3-45	13	1	20.0112.0.000	3-15	10	1
12.0008.4.231	3-39	39	2	12.0010.4.078	3-45	09	1				
12.0008.4.253	3-51	14	(1)	12.0010.4.094	3-41	59	3	22.0005.0.000			
12.0008.4.279	3-43	11	1	12.0010.4.159	3-47	08	4	22.0005.0.000	3-19	03	1
12.0008.4.280	3-23	53	1	12.0010.4.177	3-39	32	1	22.0008.0.000	3-19	02	1
12.0008.4.280	3-23	53	1	12.0010.4.178	3-39	33	1	22.0009.0.000	3-19	12	(1)

Revised 01/2010

e-mail: service@amfreece.cz; parts@amfreece.cz; website: www.amfreece.com

Phones: +420 582 309 146 (Service), +420 582 309 286 (Spare Parts); Fax: +420 582 360 606

INDEX

PART NUMBER	PAGE	DET	QTY	PART NUMBER	PAGE	DET	QTY	PART NUMBER	PAGE	DET	QTY
22.0009.0.050	3-19	28	1	22.0183.0.000	3-11	39	1	22.0545.0.000	3-31	54	1
22.0020.0.000	3-19	22	1	22.0183.0.000	3-15	18	1	22.1010.0.000	3-17	04	2
22.0021.0.000	3-11	47	1	22.0183.0.000	3-19	07	1	22.1422.0.000	3-27	20	1
22.0021.0.000	3-15	27	1	22.0184.0.000	3-11	21	3				
22.0022.0.000	3-13	55	1	22.0186.0.000	3-11	27	1	22.2410.0.000			
22.0022.0.000	3-15	31	1					22.2410.0.000	3-15	03	1
22.0023.0.000	3-15	28	1	22.0208.0.000				22.2425.0.050	3-15	19	1
22.0024.0.000	3-15	22	1	22.0208.0.000	3-11	26	1	22.2440.0.000	3-15	05	2
22.0026.0.000	3-11	40	1	22.0209.0.000	3-49	02	1	22.2442.0.000	3-15	02	2
22.0027.0.000	3-19	19	1	22.0209.0.000	3-49	02	1	22.2607.0.000	3-25	01	1
22.0028.0.000	3-19	17	2	22.0213.0.000	3-49	16	1	22.2626.0.000	3-25	03	1
22.0029.0.000	3-19	15	2	22.0214.0.000	3-19	10	1	22.2627.0.000	3-25	02	2
22.0030.0.000	3-19	26	1	22.0219.0.000	3-37	48	1	22.2631.0.000	3-29	20	1
22.0031.0.000	3-13	51	2	22.0228.0.000	3-11	12	1	22.2633.0.000	3-29	30	1
22.0031.0.000	3-15	15	2	22.0229.0.000	3-35	03	2	22.2652.0.000	3-9	19	1
22.0032.0.000	3-11	49	2	22.0230.0.000	3-3	08	2	22.2653.0.000	3-9	22	1
22.0049.0.000	3-11	31	1	22.0232.0.000	3-13	53	1	22.2655.0.000	3-9	06	1
22.0054.0.000	3-27	05	1	22.0232.0.000	3-15	24	1	22.2656.0.000	3-9	20	1
22.0057.0.000	3-33	14	1	22.0233.0.000	3-15	30	1	22.2657.0.000	3-9	23	1
22.0058.0.000	3-27	07	1	22.0239.0.000	3-3	09	2	22.2665.0.000	3-9	05	1
22.0061.0.000	3-11	07	1					22.3003.0.000	3-25	28	1
22.0062.0.000	3-27	10	1	22.0300.0.000				22.3068.0.000	3-29	01	2
22.0063.0.000	3-19	04	1	22.0300.0.000	3-31	53	1	22.3219.0.000	3-29	24*	1
22.0064.0.000	3-15	16	1	22.0305.0.000	3-11	35	1	22.3219.0.000	3-53	06	(1)
22.0064.0.000	3-19	14	2	22.0309.0.000	3-11	20	(1)	22.6002.0.000	3-27	23	1
22.0069.0.000	3-19	21	1	22.0309.0.050	3-13	59	1	22.8400.0.000	3-31	52	1
22.0097.0.000	3-25	13	1	22.0312.0.000	3-11	06	1				
22.0100.0.000				22.0313.0.000	3-11	17	(1)	23.2044.0.050			
22.0100.0.000	3-11	34	4	22.0315.0.000	3-11	22	1	23.2044.0.050	3-27	22	1
22.0100.0.000	3-15	20	3	22.0320.0.000	3-11	36	1	23.2106.0.000	3-15	09	1
22.0100.0.000	3-19	11	4	22.0325.0.000	3-11	10	1	23.2107.0.000	3-15	12	1
22.0104.0.000	3-35	06	1	22.0336.0.000	3-11	44	1				
22.0105.0.000	3-15	29	1	22.0353.0.000	3-11	48	3	24.0001.0.000			
22.0106.0.000	3-25	25	2	22.0354.0.000	3-11	04	1	24.0001.0.000	3-3	33	1
22.0106.0.000	3-29	34	1	22.0370.0.000	3-11	46	1	24.0002.0.000	3-3	28	1
22.0107.0.000	3-35	13	1	22.0400.0.000	3-9	03	1	24.0002.0.000	3-31	61	1
22.0108.0.000	3-35	08	1	22.0405.2.000	3-9	08	1	24.0003.0.000	3-7	06	1
22.0110.0.000	3-13	54	1	22.0408.0.000	3-29	09	1	24.0004.0.000	3-7	08	1
22.0110.0.000	3-19	09	1					24.0005.0.000	3-7	10	1
22.0114.0.000	3-11	02	1	22.0510.0.000				24.0006.0.000	3-7	14	1
22.0120.0.000	3-35	05	1	22.0510.0.000	3-3	03	1	24.0006.0.000	3-31	55	1
22.0121.0.000	3-11	03	1	22.0520.0.000	3-3	06	1	24.0018.0.000	3-29	15	1
22.0137.0.000	3-25	10	2	22.0525.0.000	3-3	16	(1)	24.0019.0.000	3-31	58	1
22.0143.0.000	3-31	64	1	22.0525.0.050	3-3	24	1	24.0020.0.000	3-29	45	1
22.0153.0.000	3-31	51	2	22.0530.0.000	3-3	10	1	24.0024.0.000	3-49	04	1
22.0159.0.000	3-5	16	1	22.0535.0.100	3-3	30	1	24.0027.0.000	3-29	43	1
22.0173.0.000	3-5	23	2	22.0540.0.000	3-3	14	1	24.0030.0.000	3-49	03	1
22.0175.0.000	3-3	27	1	22.0541.0.000	3-3	13	1	24.0033.0.000	3-19	25	1
22.0182.0.000	3-25	12	2	22.0542.0.000	3-3	11	1	24.0036.0.000	3-5	29	1
				22.0545.0.000	3-3	25	1	24.0038.0.000	3-17	05	1

Revised 01/2010

e-mail: service@amfreece.cz; parts@amfreece.cz; website: www.amfreece.com

INDEX

PART NUMBER	PAGE	DET	QTY	PART NUMBER	PAGE	DET	QTY	PART NUMBER	PAGE	DET	QTY
24.0048.0.000	3-3	26	1	24.2010.0.000	3-21	39	1	24.2640.2.000	3-25	26	1
24.0049.0.000	3-11	14	2	24.2012.0.000	3-21	45	1	24.2651.4.001	3-9	11	1
24.0050.0.000	3-47	37	1	24.2013.0.000	3-21	25	1	24.2664.4.000	3-9	02	1
24.0051.0.066	3-29	17	1	24.2014.0.000	3-21	06	1	24.3201.0.000	3-25	06	1
24.0059.0.017	3-41	53	1	24.2015.0.000	3-21	24	1	24.3203.0.000	3-25	08	1
24.0059.9.069	3-39	28	1	24.2016.0.000	3-9	13	1	24.3318.0.000	3-29	24*	1
24.0066.0.000	3-15	13	2	24.2017.0.000	3-9	15	1	24.3318.0.000	3-53	06	(1)
24.0067.0.000	3-33	03	1	24.2017.0.000	3-29	38	1	24.3325.0.000	3-39	43	1
24.0068.0.000	3-33	02	1	24.2018.0.000	3-29	31	1	24.4052.0.000	3-51	07	(1)
24.0069.9.006	3-39	30	1	24.2019.0.000	3-29	32	1	24.4053.0.000	3-51	03	(1)
24.0069.9.020	3-27	19	1	24.2020.0.000	3-29	33	1	24.4054.0.000	3-51	09	(1)
24.0069.9.038	3-43	01	1	24.2025.0.000	3-29	21	1	24.4055.0.000	3-51	11	(1)
24.0069.9.040	3-37	07	(1)	24.2028.0.000	3-21	34	1	24.6000.6.000	3-27	03	1
24.0080.0.000	3-7	05	1	24.2032.0.000	3-29	02	1	24.6001.2.000	3-33	10	1
24.0097.0.000	3-43	07	(1)	24.2035.0.000	3-11	29	1	24.6003.0.000	3-33	13	1
				24.2038.0.000	3-5	24	1	24.6004.1.001	3-33	06	1
24.0100.0.000				24.2040.0.000				24.6005.1.002	3-17	13	1
24.0100.0.000	3-3	36	1	24.2040.0.000	3-25	05	1	24.6100.4.000	3-29	11	1
24.0106.0.000	3-27	29	1	24.2042.0.000	3-21	09	1	24.6102.4.001	3-29	06	1
24.0108.0.000	3-27	15	1	24.2043.0.000	3-21	13	1	24.6102.4.002	3-29	05	1
24.0111.0.000	3-17	01	1	24.2044.0.000	3-21	12	1	24.6102.4.004	3-5	36	1
24.0112.0.000	3-33	11	1	24.2045.0.000	3-21	15	1	24.8001.1.002	3-39	11	(1)
24.0125.6.000	3-5	37	1	24.2046.0.000	3-21	16	1	24.8001.2.001	3-45	06	1
24.0126.0.000	3-11	05	1	24.2047.0.000	3-21	14	1	24.8001.2.005	3-45	04	
24.0127.0.000	3-11	42	1	24.2048.0.000	3-21	27	1				
24.0139.0.000	3-35	02	1	24.2049.0.000	3-21	44	1				
24.0140.0.000	3-13	60	1	24.2050.0.000	3-21	50	1				
24.0141.0.000	3-35	01	1	24.2053.0.000	3-21	07	1				
24.0146.0.000	3-39	08	(1)	24.2058.0.000	3-5	39	1				
24.0147.0.000	3-39	10	(2)	24.2061.1.000	3-47	09	1				
24.0148.0.000	3-39	18	1	24.2064.0.000	3-5	14	1				
24.0154.0.000	3-33	16	1	24.2065.0.000	3-31	63	1				
24.0157.0.000	3-5	17	1	24.2066.0.000	3-29	10	1				
24.0158.0.000	3-5	34	1	24.2067.0.000	3-21	49*	1				
24.0195.4.000	3-3	01	1	24.2067.0.000	3-53	05	(1)				
24.0226.4.000	3-5	04	1	24.2068.0.000	3-21	47*	1				
24.0227.4.000	3-5	02	1	24.2068.0.000	3-53	03	(1)				
24.0351.0.000	3-11	09	1	24.2069.0.000	3-21	05	1				
24.0500.0.000	3-3	19	1								
24.1000.0.000	3-31	57	1								
				24.2070.0.000							
24.2001.0.000				24.2070.0.000	3-27	18	1				
24.2001.0.000	3-21	22	1	24.2071.2.000	3-21	41	1				
24.2002.0.000	3-21	30	1	24.2072.0.000	3-47	38	1				
24.2004.0.000	3-21	29	2	24.2073.2.000	3-5	08	1				
24.2005.0.000	3-21	31	1	24.2074.0.000	3-5	15	1				
24.2006.0.000	3-21	36	1	24.2075.3.000	3-5	32	1				
24.2007.0.000	3-21	32	1	24.2075.4.000	3-49	29*	1				
24.2008.0.000	3-21	37	1	24.2076.0.000	3-5	09	2				
24.2009.0.000	3-21	35	1	24.2400.0.000	3-29	47	1				

Revised 01/2010

e-mail: service@amfreece.cz; parts@amfreece.cz; website: www.amfreece.com

Phone: +420 582 309 286; Fax: +420 582 360 606

INDEX
