



MODEL S-4000 ISBH Omron

STRAIGHT BUTTONHOLE MACHINE FOR IMITATION SLEEVE BUTTONHOLES

PARTS AND SERVICE MANUAL

MACHINE SERIAL No.:

PART NUMBER 97.2433.1.001

This manual is valid from the machine serial No. M241403



LIMITED WARRANTY ON NEW AMF REECE EQUIPMENT

Warranty provisions:

A ninety (90) day limited service labor warranty to correct defects in installation, workmanship, or material without charge for labor. This portion of the warranty applies to machines sold as "installed" only.

A one (1) year limited material warranty on major component parts to replace materials with defects. Any new part believed defective must be returned freight prepaid to AMF Reece, Inc. for inspection. If, upon inspection, the part or material is determined to be defective, AMF Reece, Inc. will replace it without charge to the customer for parts or material.

Service labor warranty period shall begin on the completed installation date. Material warranty shall begin on the date the equipment is shipped from AMF Reece, Inc.

Exclusions:

Excluded from both service labor warranty and material warranty are: (1) Consumable parts which would be normally considered replaceable in day-to-day operations. These include parts such as needles, knives, loopers and spreaders. (2) Normal adjustment and routine maintenance. This is the sole responsibility of the customer. (3) Cleaning and lubrication of equipment. (4) Parts found to be altered, broken or damaged due to neglect or improper installation or application. (5) Damage caused by the use of non-Genuine AMF Reece parts. (6) Shipping or delivery charges.

There is no service labor warranty for machines sold as "uninstalled".

Equipment installed without the assistance of a certified technician (either an AMF Reece Employee, a Certified Contractor, or that of an Authorized Distributor) will have the limited material warranty only. Only the defective material will be covered. Any charges associated with the use of an AMF Reece Technician or that of a Distributor to replace the defective part will be the customer's responsibility.

NO OTHER WARRANTY, EXPRESS OR IMPLIED, AS TO DESCRIPTION, QUALITY, MERCHANTABILITY, and FITNESS FOR A PARTICULAR PURPOSE, OR ANY OTHER MATTER IS GIVEN BY SELLER OR SELLER'S AGENT IN CONNECTION HEREWITH. UNDER NO CIRCUMSTANCES SHALL SELLER OR SELLER'S AGENT BE LIABLE FOR LOSS OF PROFITS OR ANY OTHER DIRECT OR INDIRECT COSTS, EXPENSES, LOSSES OR DAMAGES ARISING OUT OF DEFECTS IN OR FAILURE OF THE EQUIPMENT OR ANY PART THEREOF.

WHAT TO DO IF THERE IS A QUESTION REGARDING WARRANTY

If a machine is purchased through an authorized AMF Reece, Inc. distributor, warranty questions should be first directed to that distributor. However, the satisfaction and goodwill of our customers are of primary concern to AMF Reece, Inc. In the event that a warranty matter is not handled to your satisfaction, please contact AMF Reece office:

Prostejov, Czech Republic
Phone: (+420) 582-309-286
Fax: (+420) 582-360-608
e-mail: service@amfreece.cz



Warranty Registration Card

(Please Fax or Mail immediately after installation)

Note: All Warranty Claims Void, unless Registration Card on file at AMF Reece HQ

Machine model number:

(S100, S101, S104, S105, S 311, Deco, S4000 , EBS Mark II, ES505, etc)

Manufacturer's serial or production number:

Installation Site Information:

Customer's Name:

Customer's Mailing Address:

Customer's Telephone Number:

Supervising Mechanic's or Technician's Name:

Signature of Supervising Technician:

AMF Reece Technician's Name:

AMF Reece Technician's Signature:

Type of garment produced at this location?

Average Daily Production Expected from this machine?

(number of buttonholes, jackets sewn, pants produced, buttons sewn, etc)

Any special requirements required at this location?

What other AMF Reece Machines are at this location?

How can we serve you better?

Tovární 837, 798 11 Prostejov, Czech Republic

Fax: +420 582 360 606, e-mail: service@amfreece.cz, website: www.amfreece.com

TABLE OF CONTENTS

A - INTRODUCTION

1. Basic information	1-1
2. Safety devices and labels	1-2
3. General machine parts descriptions	1-3
4. Specifications	1-4
5. Table type	1-5
6. Instructions for operator safety and maintenance	1-6
6. Special accessories	1-7

B - MACHINE ASSEMBLY

1. Contents of the shipping box	1-9
2. Accessories	1-9
3. Power and air connection	1-10
4. Thread stand installation	1-12

C - PROPER APPLICATION

1. Power up / home position	1-13
2. Needle installation	1-14
3. Threading	1-15

D - MACHINE CONTROLS

1. Progress for sewing a buttonhole	1-16
2. Operator controls	1-17
3. Control panel information	1-18
4. The programming menu	1-19
5. Tests	1-21
6. Program version	1-23
7. Parameter checklist	1-24

E - MACHINE ADJUSTMENT

1. Machine home position	1-25
2. Main Cam Adjustment	1-26
3. The principles for the machine adjustment	1-26
4. Needle bar	1-27
5. Bite	1-28
6. Feeding	1-30
7. Slip clutch	1-31
8. Stitch density	1-31

TABLE OF CONTENTS

E - MACHINE ADJUSTMENT

9. Adjustment of Barring Stitches	1-32
10. Space between the first and second row of stitches	1-34
11. Buttonhole length change	1-35
12. Loopers adjustment	1-36
13. Thread draw-off	1-39
14. Thread tension	1-40
15. Thread trimming	1-42
16. Machine clamp feet adjustment	1-43
17. Adjustment of the stopping sensor position	1-44
18. Changing the drive belt	1-45
19. The main cam change.....	1-46

F - MACHINE MAINTENANCE

1. Machine cleaning and maintenance	1-48
2. Periodic maintenance	1-50
3. Lubrication diagram	1-51
4. Machine lubrication	1-52
5. Machine disposal	1-54

G - PNEUMATIC DIAGRAM

H - ELECTRICAL DIAGRAM

A - INTRODUCTION

1. BASIC INFORMATION

The sewing machine S4000 ISBH is designed and produced to be very reliable. Important design goals have been to provide a safe machine that is simple and inexpensive to maintain.

The patented rotary needle bar shaft drive, a major benefit, delivers longer needle bar life. The added benefits of lower vibration and less noise, translate into less operator fatigue.

Simple buttonhole length adjustment located outside the machine, eliminates the need for tilt back, while the quick stop repair function delivers safety and makes repairs easier.

Special electronic and mechanical safety devices protect the operator and the machine. There is a special power lock out switch that permits the machine to be locked in the off position, so that it cannot be cycled accidentally. There is an emergency off switch. There is a low air pressure detector that will not permit machine operation if air pressure is dangerously low.

There are safety-warning labels on the machine in all areas that require special care. These must not be removed. If they are lost replace them immediately.

You are the most important safety equipment of all. Be sure you understand the proper operation of the machine. Never remove safety mechanisms or labels. We have made every effort to provide the safest possible machine, but without complete knowledge of how this machine operates, and the use of proper care by the operator, this machine can cause serious injury or death. That is why there are safety warnings throughout these instructions that carry one of these messages.

DANGER! Possible loss of life.

WARNING! Possible serious injury or machine damage.

NOTICE! Possible injury or machine damage.

We recommend that service workers from AMF Reece oversee the installation and initial training of your mechanics and operators.

The most effective safety precaution is a well-managed safety program. Be sure those who use this machine are properly trained. Never disable safety equipment.

Always wear safety goggles when operating or servicing the machine.

A - INTRODUCTION

SAFETY DEVICE AND LABELS

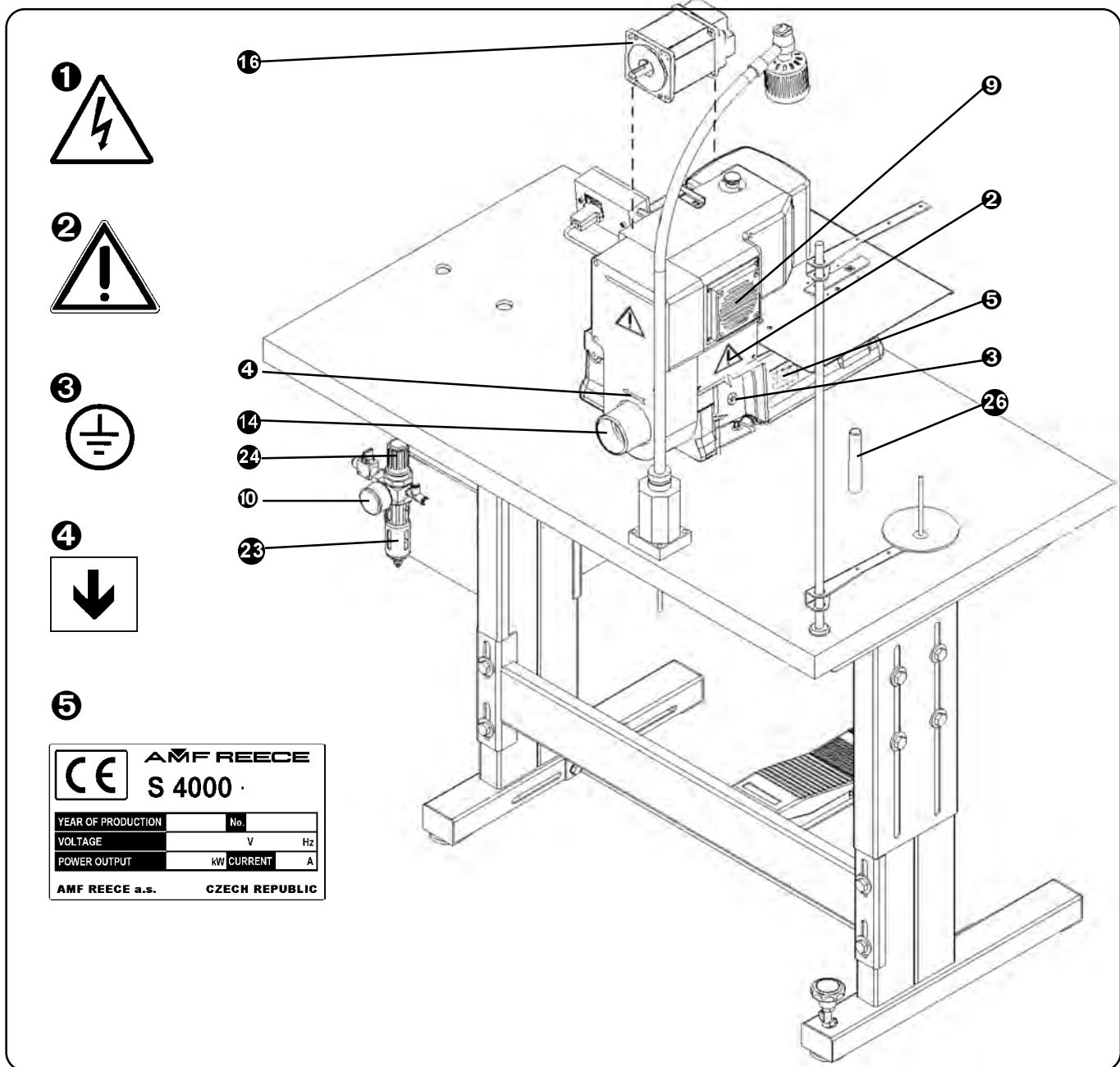

- 1 Warning
- 2 Covers removed, possible injury
- 3 Grounding
- 4 Rotational direction
- 5 Standard Label
- 6 Needle bar cover
- 7 Eye guard
- 8 Head cover
- 9 Fan cover
- 10 Manometer with pressure sensor
- 11 Machine head
- 12 Table

A - INTRODUCTION

3. GENERAL MACHINE PARTS DESCRIPTIONS

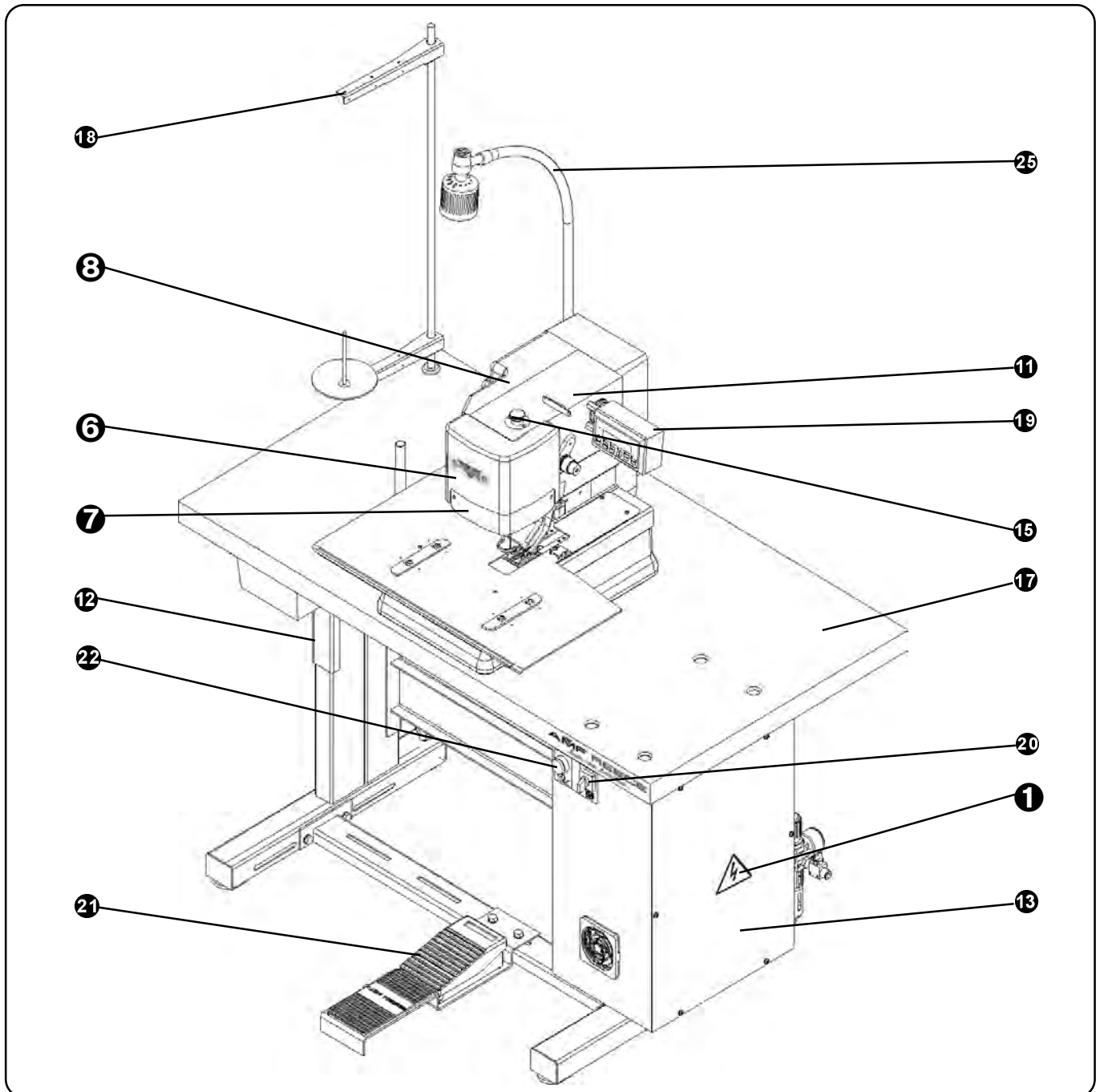

- 13 Control box
- 14 Hand wheel
- 15 Emergency Stop Button
- 16 Motor
- 17 Table top
- 18 Thread Stand
- 19 Control panel

- 20 Main switch
- 21 Foot pedal
- 22 Clamps Up/Down
- 23 Air pressure regulator
- 24 Air pressure adjustment knob
- 25 Halogen Lamp
- 26 Rest Pin

Revised 01/2009

e-mail: service@amfreece.cz; parts@amfreece.cz; website: www.amfreece.com

Phone: +420 582 309 146 (Service), +420 582 309 286 (Spare Parts); Fax: +420 582 360 606

A - INTRODUCTION

4. SPECIFICATIONS

Machine type	S 4000 ISBH
Description	electronic controlled chain stitch straight buttonhole machine for sewing imitaion buttonholes on cuff Wiggins
Sewing speed	1500-3800 stitches/min (500 - 1900 rev/min of the drive shaft)
Buttonhole length	15.8 - 25 mm (5/8" - 1")
Stitch density	4 - 12 stitches/cm (10 - 30 spi)
Type of the buttonhole	single thread chain stitch without center cutting
Machine clamp foot height	12.7 mm (1/2")
Maximum work thickness	to 4 mm (5/32")
Bite range	1.6 - 2.3 (1/16" - 3/32")
Distance between the first and the second row of stitches	0 - 0.9 mm
Recommended thread	thread size 80, 100, 120
Needle system	Needle 750 SC 90/14 (it is possible to order 80/12)
Lubrication	semi-automatic
Operating Conditions	according to IEC 364-3, IEC 364-5-51 temperature from +5°C to 40°C, relative air humidity from 30 to 80 %
Air pressure	0.55 MPa (80 PSI)
Machine db level	Laeg = 74dB; LWA = 87dB; LpC, peak = 103dB
Machine head dimension	340 mm (height) x 470 (width) x 250 mm (length)
Machine head weight	62 kg
Table Dimension	700 mm (height) x 600 mm (width) x 1100 mm (length)
Electrical Requirements	1NPE~60Hz 230V/TN-S (according to EN 60204-1)
	1NPE~50Hz 230V/TN-S (according to EN 60204-1)
Line Circuit Breaker	10A characteristic C (according to EN 60947-2)
	16A characteristic B (according to EN 60947-2)

A - INTRODUCTION

5. TABLE TYPE

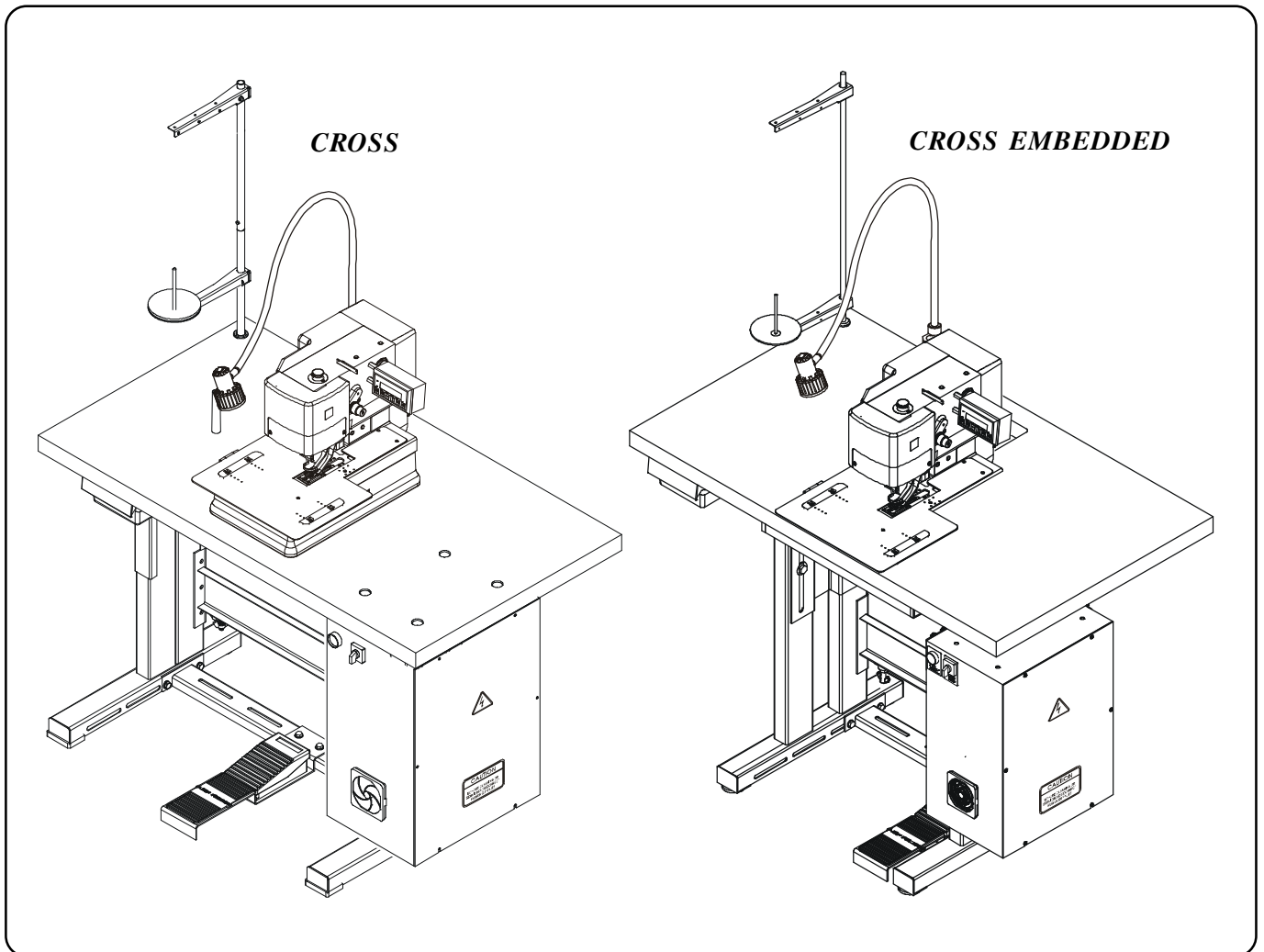

Revised 01/2009

e-mail: service@amfreece.cz; parts@amfreece.cz; website: www.amfreece.com

Phone: +420 582 309 146 (Service), +420 582 309 286 (Spare Parts); Fax: +420 582 360 606

A - INTRODUCTION

6. INSTRUCTIONS FOR OPERATOR SAFETY AND MAINTENANCE

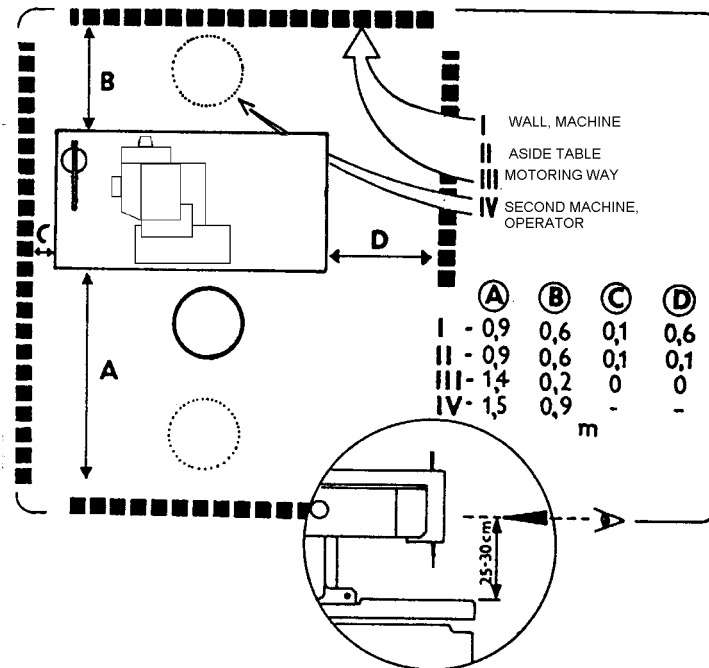

When installing the machine we recommend the minimum clearances noted above around the machine. Read all of the instructions that follow. **DO NOT PUT THE MACHINE INTO OPERATION UNTIL YOU ARE COMPLETELY FAMILIAR WITH ALL INSTALLATION AND OPERATING INSTRUCTIONS.**

DANGER!

- Before connecting the machine to the power supply, be positive that all safety covers are correctly installed.
- Always engage the power lockout switch, or disconnect the main power supply, before removing any safety covers.

WARNING!

- Locate the Emergency Stop button. Be sure you know how to use it.
- Be sure that you have a reliable and uniform power supply.
- Be sure that all electrical supply lines are in good condition and have no signs of damage to avoid electrical shock.
- If any covers become damaged, they must be repaired or replaced immediately.
- Do not touch moving parts of the machine while it is operating.
- Keep clear of the needle.
- Always switch off the main power before changing the needle.
- Before cleaning the machine or performing service to the machine, engage the power lock out switch or disconnect the main power supply.
- When the machine is not in use engage the power lock out switch or disconnect the main power supply.
- When this machine is used incorrectly, or is incorrectly maintained, it can be dangerous. Everyone who uses this machine, or maintains this machine, must be completely familiar with this manual.

A - INTRODUCTION

CAUTION!

- Perform all regular service as described by this manual.
- If there is any problem with the power supply, turn off the main power switch.
- Do not remove, paint over, damage or in any way change safety labels. If a safety label cannot be easily read, replace it.
- Long hair and loose clothing may be dangerous near any machinery. Always contain long hair and avoid loose clothing, so that it cannot be caught by machinery and cause injury.
- Never use this machine while under the influence of drugs or alcohol.
- If anything seems to be operating incorrectly in the machine call for maintenance assistance immediately.
- Be sure that there is adequate light for safe operation. A normal minimum light level is 750 lux.

6. SPECIAL ACCESSORIES

- machine device, which is not included in the standard equipment of the machine and a customer can order it

Light

- customer can order - no. 12.0008.4.403
- connection according to chart (terminal connectors X0; cable clamps N,L)

Warning: When installing the light on the machine, disconnect the machine from the power supply.

- in case, you do not want to interfere into the machine wiring, it is possible to order the work light LBH-T65, order no. 12.0008.4.875, which contains its own clip fork the table and supply conductor with forprk (plug) CEE7 for connection to the power supply ~ 230 V.

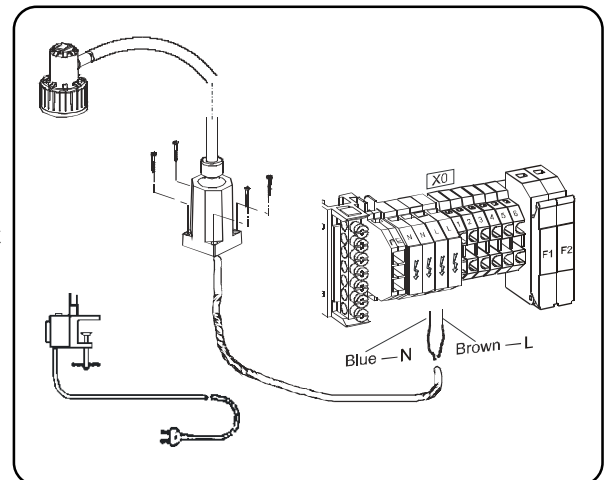

A - INTRODUCTION

Sewing cam

- it is possible to sew a different buttonhole shape E than standard buttonhole ②, ③ is
- a customer can order it - ② part number 24.3079.0.000
- ③ part number 24.3080.0.000
- to change a cam - see section E20

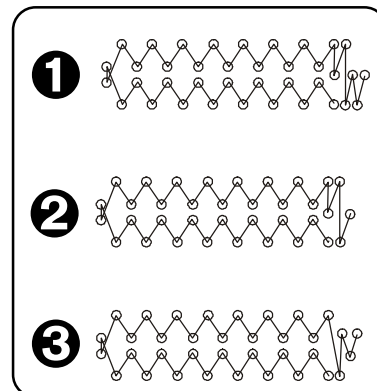

Needles 750 SC 80/12, 70/10

- the manufacturer recommends to use these needles when sewing the thin materials
- part number 02.0750.2.100 (80/12), 02.0750.2.109 (70/10)

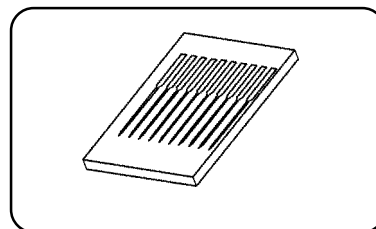

Connector Ø 8 ①

- order it if the connecting tube has the inner diameter 8 mm. The connector Ø 10 is supplied with the machine.
- part number is 12.0008.3.607

Pneumatic Adapter ②

- order it if using 1/8" NPT
- part number 12.0008.3.081

Hand valve ③

- to dissipate any air from the machine, order it (air circuit is bled). It is necessary to order the connectors (see below) to the hand valve for connection to the air tubes.
- part number 12.0008.3.463

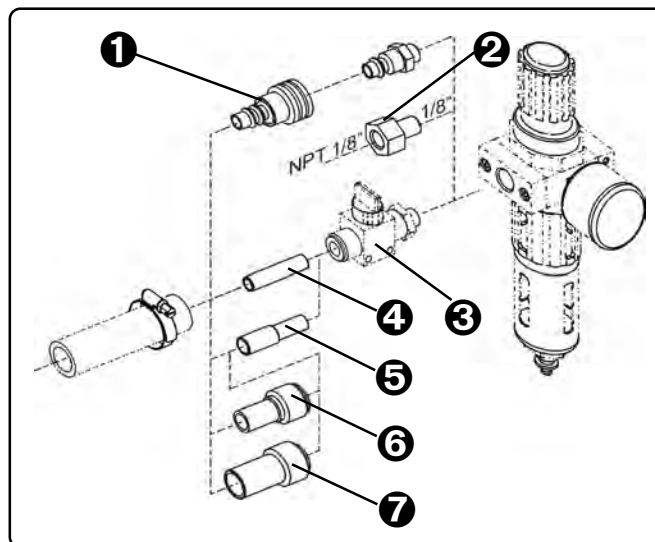

Connectors

④	12.0008.3.464	Ø 8	for connection to the tube with inner Ø 8 mm
⑤	12.0008.3.466	Ø 10	for connection to the tube with inner Ø 10 mm
⑥	12.0008.3.467	Ø 12	for connection to the tube with inner Ø 12 mm*
⑦	12.0008.3.465	Ø 16	for connection to the tube with inner Ø 16 mm*

* To connect the tube with inner Ø 12 and Ø 16, it is also necessary to order Ø 10

B - MACHINE ASSEMBLY

1. CONTENT OF THE SHIPPING BOX

1. The shipment contains one box.
2. There is a carton with accessories, service manual with parts section and thread stand ❶ in the box.
3. During unpacking the shipment, follow the labels which are on a cover.

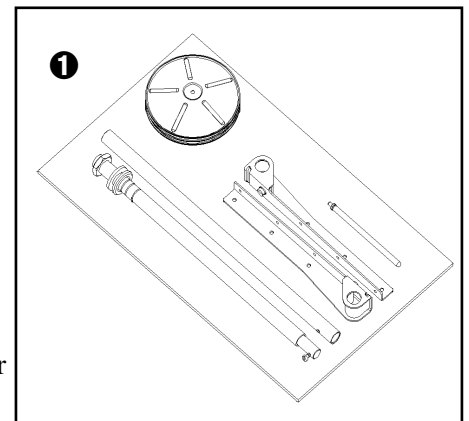

CAUTION: If the machine or crate was damaged in shipment inform the freight company immediately. Check the contents of the crate immediately and report any damage or missing items to the manufacturer immediately, late reports will not be considered.

2. ACCESSORIES

A package of accessories is supplied with this machine, please refer to page 3-69 for detailed descriptions. The height of the working area is standardly set in range 830 - 850 mm from the manufacturer and for embedded table is in range 780 — 800 mm. When using this height of the working area, recommended height of the operator seat is in range 430 - 460 mm. The height of the table can be set in range 670 - 880 mm by screws ❸. Remove the shipping strap ❷ after unpacking the machine, the use of this strap is recommended anytime the machine is

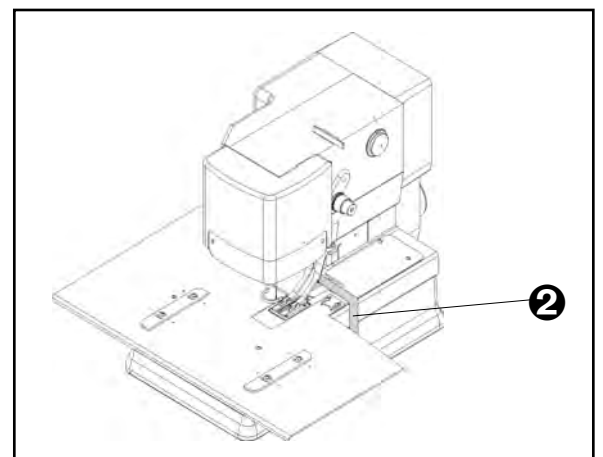
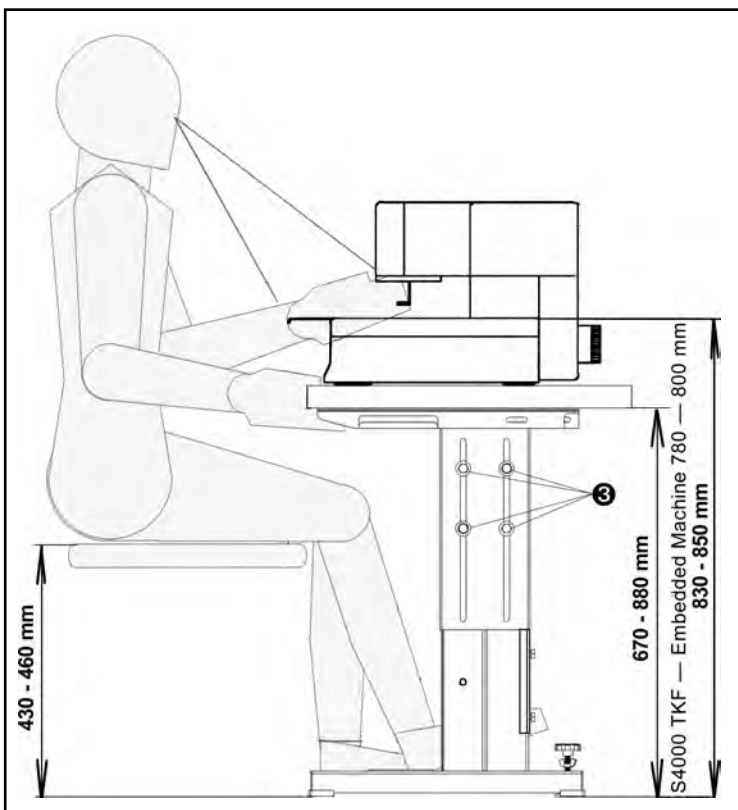
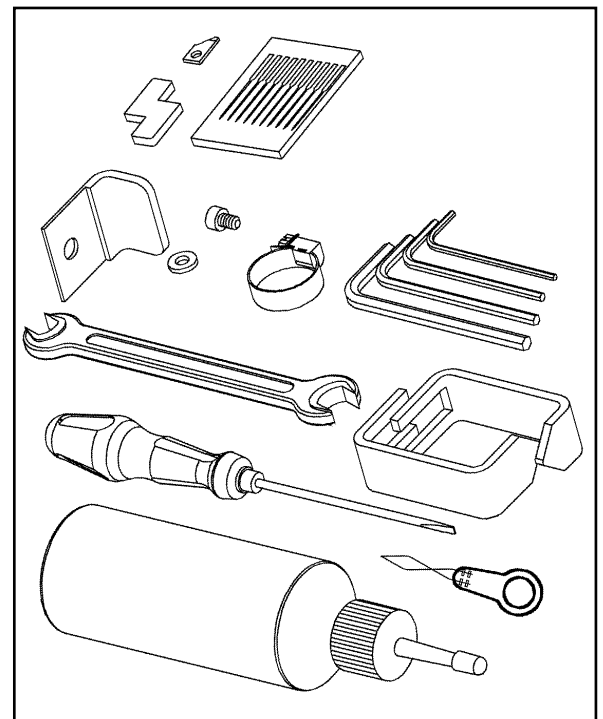

Revised 01/2009

e-mail: service@amfreece.cz; parts@amfreece.cz; website: www.amfreece.com
 Phone: +420 582 309 146 (Service), +420 582 309 286 (Spare Parts); Fax: +420 582 360 606

B - MACHINE ASSEMBLY

3. POWER AND AIR CONNECTION

- The machine is equipped with a quick coupler **4** required with connector for inner \varnothing of the tube 10. The connector for inner \varnothing of the tube 8 is not supplied with the machine, a customer has to order it. The manufacturer recommends to use connector **6** for customers who requires to connect the tube with connector NPT.

If a customer needs to use a shut off valve **1**, which allows fast releasing of the air from the circuit, he must order it.

A variety of connectors **2** can be used separately or in combination to adapt to the available input supply hose. It depends on type of the tube which is used by a customer. These connectors are not included in the accessories. A tubing clamp **3** is provided.

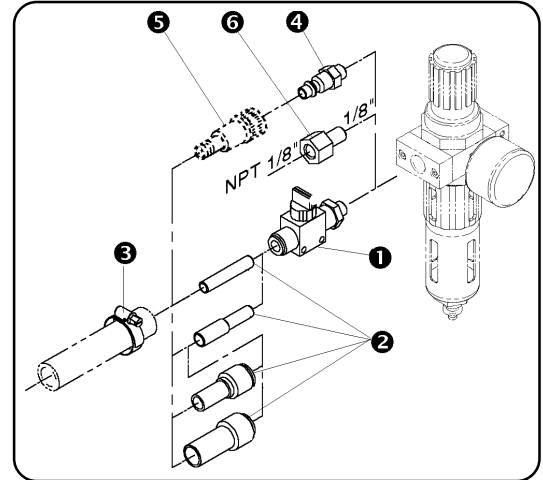

NOTE: Parts **1**, **2**, **5**, **6** are included in Extra Parts - see 3-69.

- After air connection check the set air pressure on the dial of the regulator. It should be in range 0.5 - 0.6 MPa. The green pointer **7** indicates the lowest working air pressure 0.5 MPa, which is set from the manufacturer on the regulator **8**. If the air pressure is lower than 0.5 Mpa after connecting the machine to the power supply „Low Pressure“ message appears on the control panel display. To adjust the working pressure, loosen the regulator cap lock **10** and turn the regulator cap clockwise to increase the pressure. Push the regulator cap **10** down.
- Power supply must be 208 to 230 volts 1 phase, 50 or 60 hertz. Receptacle plug must meet requirements of IEC standard 364-4-41, its circuit breaker must be minimal 10A with characteristic C according to the EN 60947-2 (or 16A with characteristic B). No other devices must not be connected to the circuit breaker of the socket. The hand wheel **12** must turn counter clockwise. **The machine is equipped with a filters which contain capacitors which generate an high frequency leakage current. In order to prevent nuisance tripping, residual current protection device must be protected against these high frequency currents: this is the case for industrial residual current device (example „S“ type).**

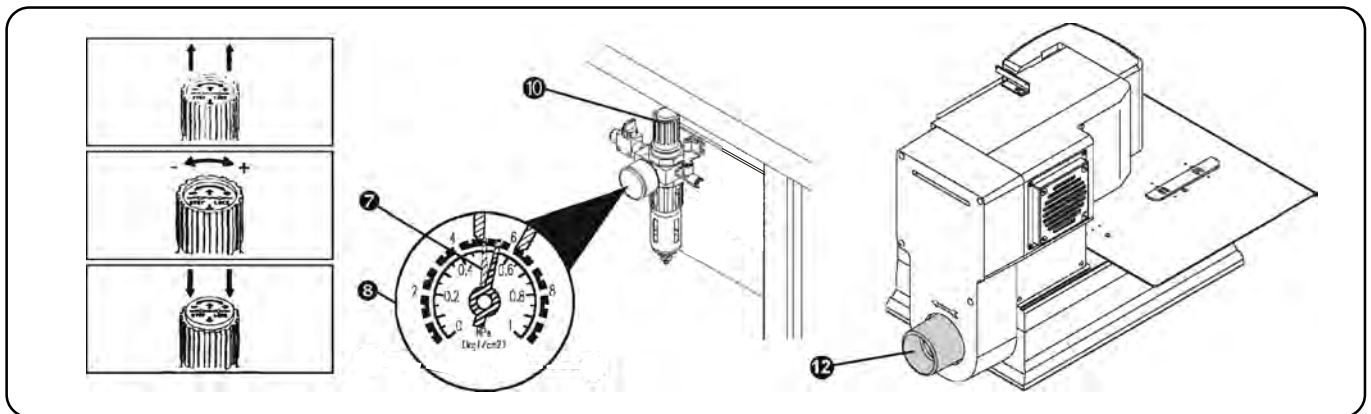

B - MACHINE ASSEMBLY

4. Head Pneumatic

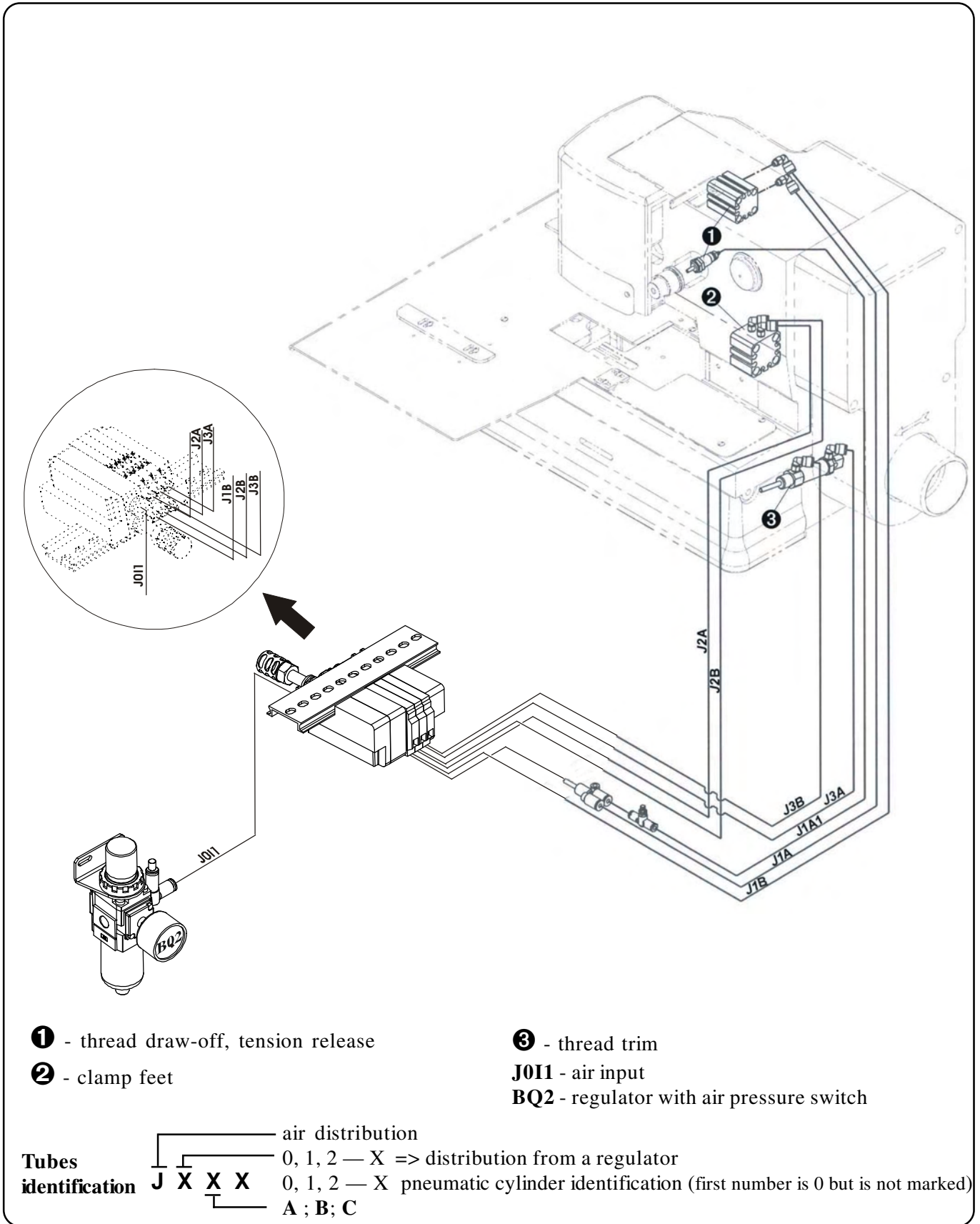

Revised 06/2009

e-mail: service@amfreece.cz; parts@amfreece.cz; website: www.amfreece.com

Phone: +420 582 309 146 (Service), +420 582 309 286 (Spare Parts); Fax: +420 582 360 606

B - MACHINE ASSEMBLY

4. THREAD STAND INSTALLATION

1. Put the thread stand together according to the drawing.
2. Position of the locking ring **1** allows assembly of the thread stand for various thickness of the table top. Threaded end of the post **6** must not extend more than 1 mm (1/32) through the locking nut **5**.
3. Insert the washer **2** and the post into the hole provided in the right rear of the table top **3**. Insert the washer **4** and tighten the nut **5**.

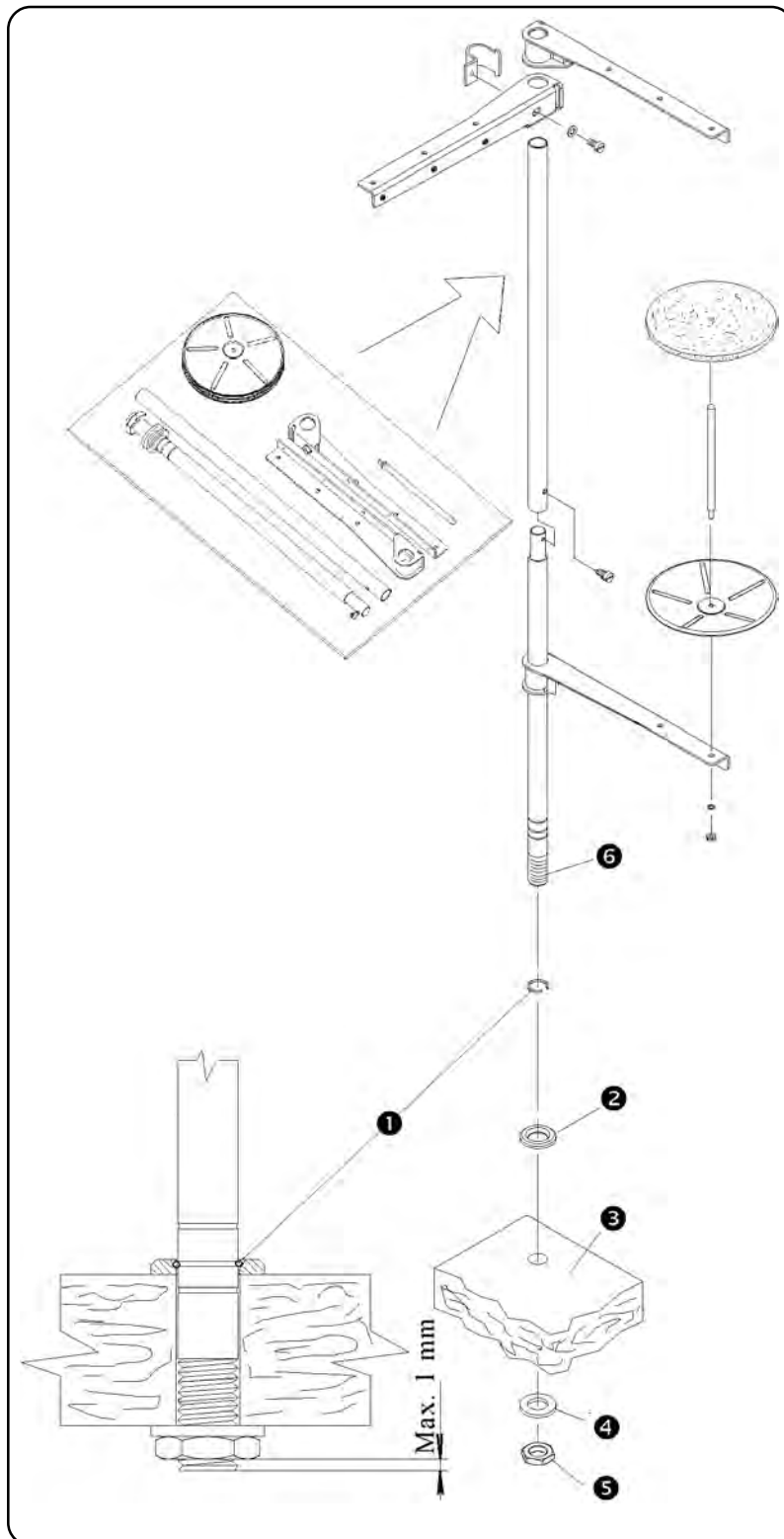

C - PROPER APPLICATION

1. POWER UP / HOME POSITION

1. Turn the main power switch on **1** by turning clockwise to the **I** position.
2. The machine is ready for operation when the control panel display lights, the Ready message appears on the display and the green LED lights on display.



The machine must be in the home position before starting to sew (to be certain, press the foot pedal and sew one dummy buttonhole).

3. It is possible to instal power voltage control (Voltage monitoring relay HRN 35) in to the machine control system. This power voltage control cautions a machine operator if the supply voltage is not in the required range (185V - 255V) and the machine could be damaged - see section **E19**.

Note: The power voltage guard is installed in the machine only if a customer has ordered it with a machine.

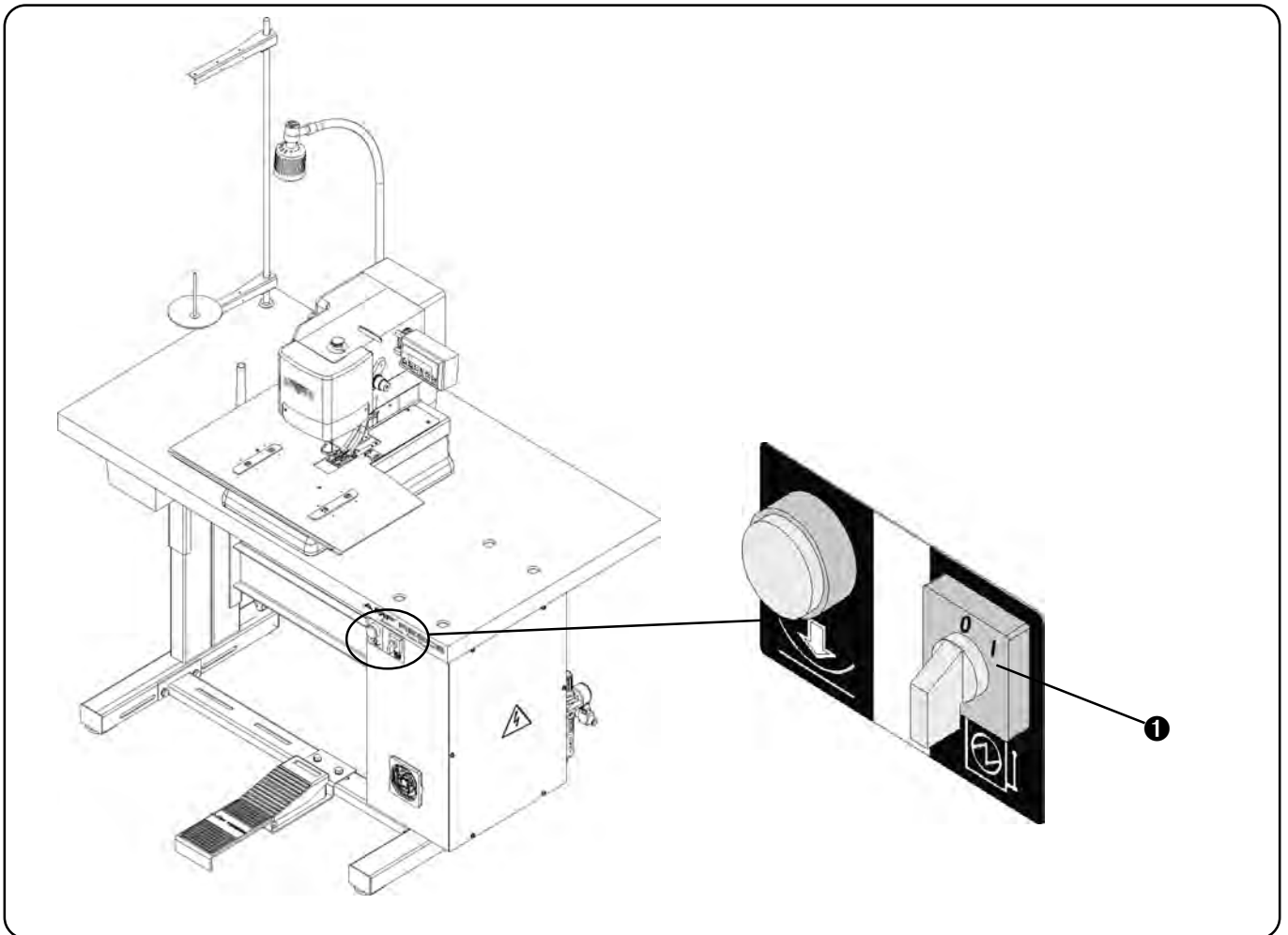

C - PROPER APPLICATION

2. NEEDLE INSTALLATION

WARNING! Before performing this adjustment, switch the main machine power off to prevent accidental starting of the machine. Disconnect the air supply and dissipate any stored energy.

Use needles ordering number 02.0750.2.110 (750SC 90/14) only - see accessories.

It is also possible to use needles ordering number 02.0750.2.100 (750 SC 80/12) for sewing the thin materials - these needles are not included in the standard machine equipment.

- Using the screwdriver push the latch **1** and open the needle bar cover **2**.

Note: The accessories contain the lever **5** (ordering number 22.0213.0.000) and screw (ordering number 08.6000.4.005) with washer (08.6850.4.000) **6**, which is possible to fit to the latch. It allows opening of the cover without using the tool.

- Loosen the screw **3** and remove the needle.
- Insert the new needle so that the long thread groove **4** is in the rear and the spot for the clamping screw **3** is in line. Do not install a bent or broken needle. Roll the needle on a flat surface to check for straightness.
- Tighten the screw **3** well.

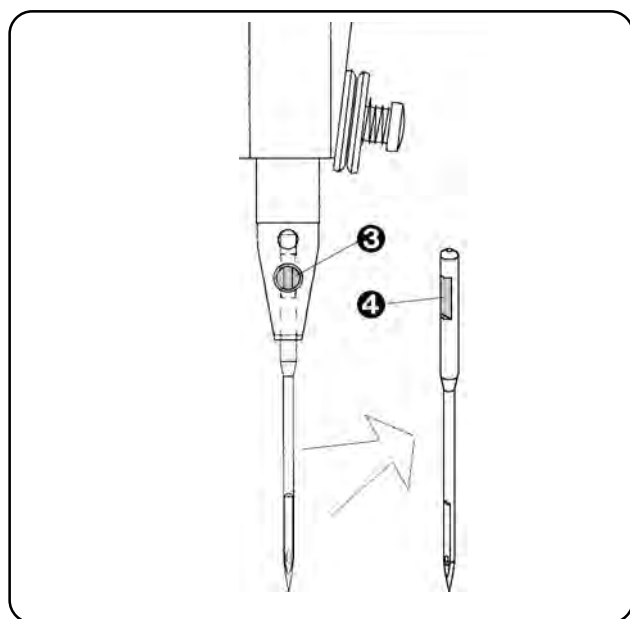
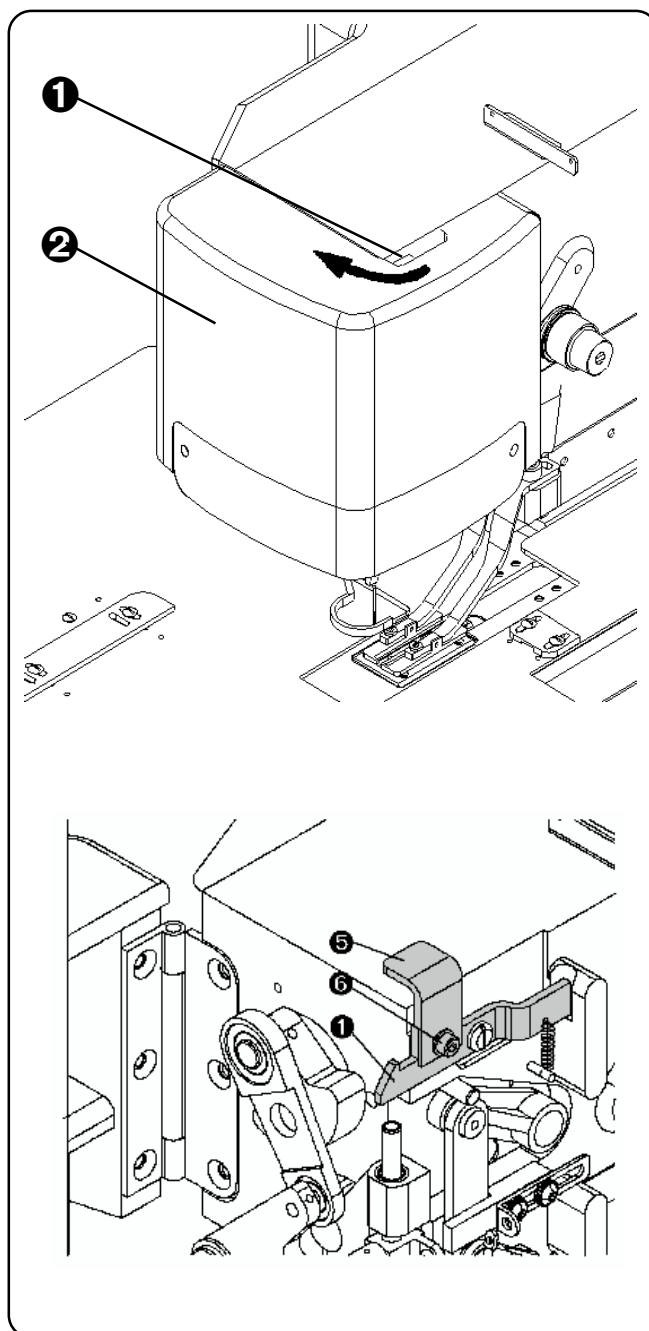

C - PROPER APPLICATION

3. THREADING

WARNING! Switch the main machine power off to prevent accidental starting of the machine. Disconnect the air supply and dissipate any stored energy.

When threading, see the pictures below. Change the thread tension by nut **1** according to the sewing conditions. To increase the thread draw off (for example sewing on the thin fabrics) there is an arm **2** installed on the thread draw off lever.

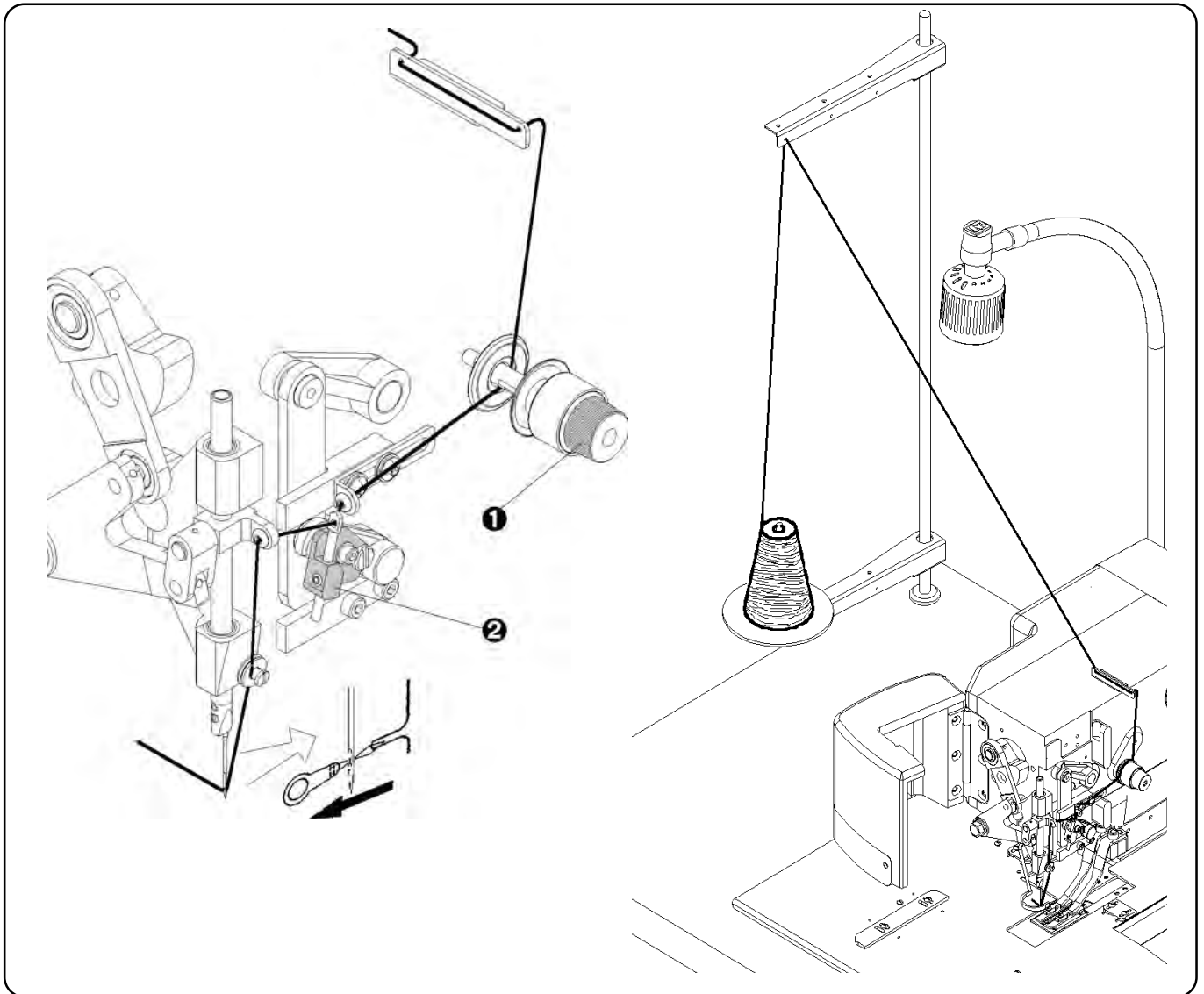

The appearance and quality of the buttonhole may be affected by one or more of the following:

- clamping of the material
- bartack quality
- thread tension
- type of thread (size, etc.)
- sewing width
- sewn material (thickness, density)

Revised 01/2009

e-mail: service@amfreece.cz; parts@amfreece.cz; website: www.amfreece.com

Phone: +420 582 309 146 (Service), +420 582 309 286 (Spare Parts); Fax: +420 582 360 606

D - MACHINE CONTROLS

1. PROGRESS FOR SEWING A BUTTONHOLE

1. Bring the machine to the home position according to the section C1.
2. Be certain that the machine is threaded correctly according to the section C3 and insert the sewn work under the clamp feet. To place a buttonhole, use the adjustable front stop ❶ and side gages ❷.
3. When the foot pedal ❸ is pressed to the first position, the sewn work is clamped by the head clamp feet. (Releasing the foot treadle will raise the clamp feet).

Note: It is possible to set the control so that both the clamping and the sew start are simultaneous, consult the programming section for this information.

4. When the foot pedal is pressed to its second position, the sewing is started. When the buttonhole is sewn and the thread is trimmed, the machine goes to the home position and clamp feet raise.
5. When the clamp feet are up, it is possible to move the sewn work for sewing the second buttonhole.
6. Machine can be stopped in any place of the cycle by pressing the Emergency Stop button ❹ which is placed on the machine head. After releasing the Emergency Stop button, pressing  button and pressing the foot pedal, the machine finishes the buttonhole.
7. When the work is done, switch the machine off by ❺ button (to O position), then stop the air supply by closing valve which is behind the regulator.

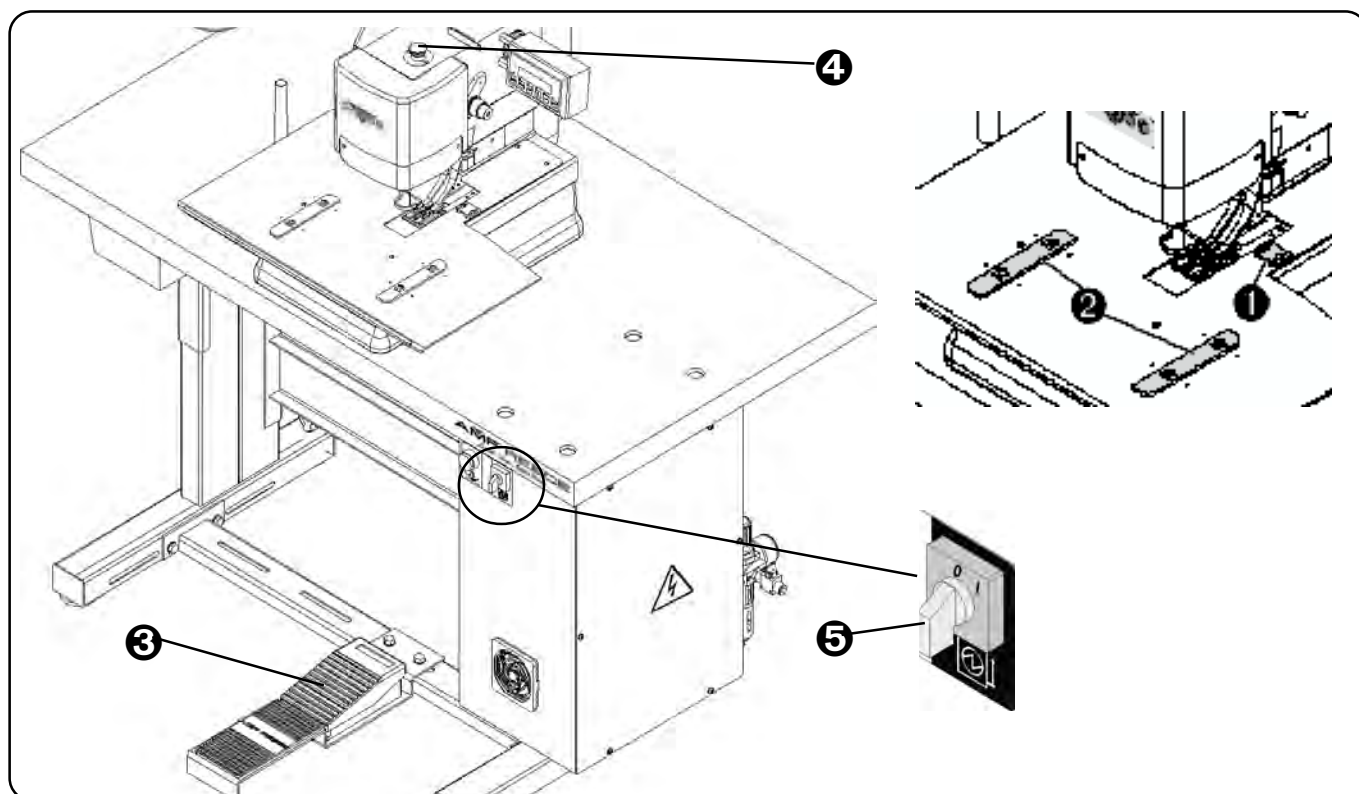

D - MACHINE CONTROLS

2. OPERATOR CONTROL PANEL PUSH BUTTONS AND SWITCHES

Red LED - activated when the Emergency Stop button is activated

Green LED - activated when the machine is Ready for sewing

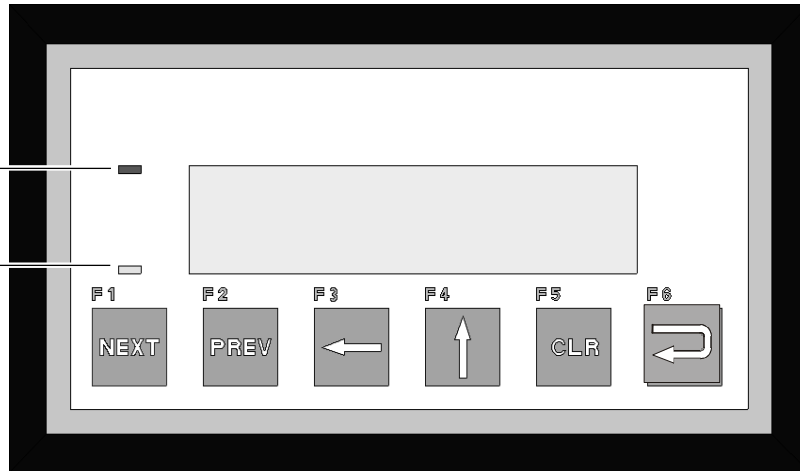

F1



Next - scrolling down key

F2



Previous - scrolling up key

F3



Key for setting the parameter value

F4



Key for setting the parameter value

F5



Clear Key - return to the main screen, return to the last changed screen or last viewed screen

F6



Enter Key



Emergency Stop Button



Clamps Button

D - MACHINE CONTROLS

3. CONTROL PANEL INFORMATION

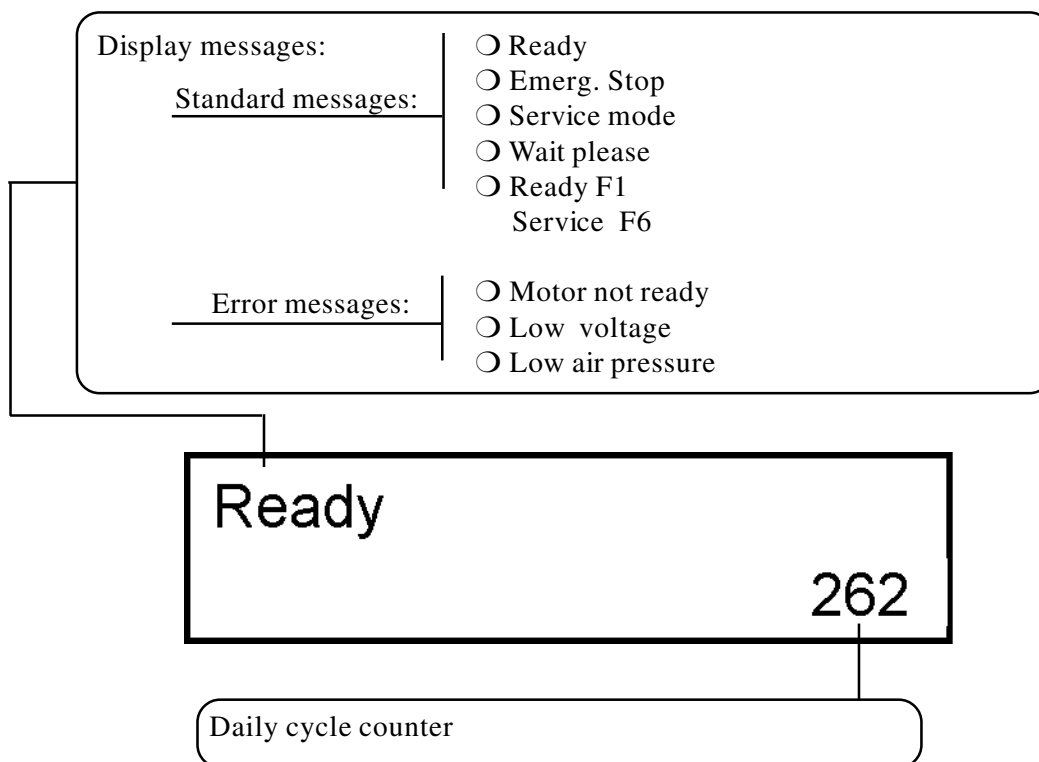











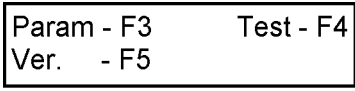

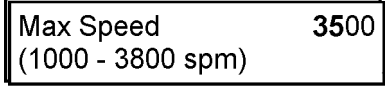
WARNING! Keep hands out of the needle area during any adjustment. Machine start is controlled by the foot pedal. Keep your foot off of the foot pedal.

Error messages on the display are mentioned in *Troubleshooting* section.

D - MACHINE CONTROLS

4. THE PROGRAMMING MENU

Main screen  - press  (F1),  appears on the display. To enter the programming menu, press  (F3).  appears on the display. The first line of the display shows the parameter, which is set, and the second line indicates the range of setting. To scroll the lines down, press  (F1) key, to scroll the lines up, press  (F2) key. To change the value of any parameter, press  (F6) key. Press  (F4) key to set the first digit. Press  (F3) key. The second digit starts flashing on the display, to set the value, press  (F4) key. Press  (F3) key. The third digit starts flashing on the display. Repeat this setting until all digits of the parameter are set. To confirm the set value of a parameter, press  (F6) key.

Example: To change the sewing speed from 2000 to 3450

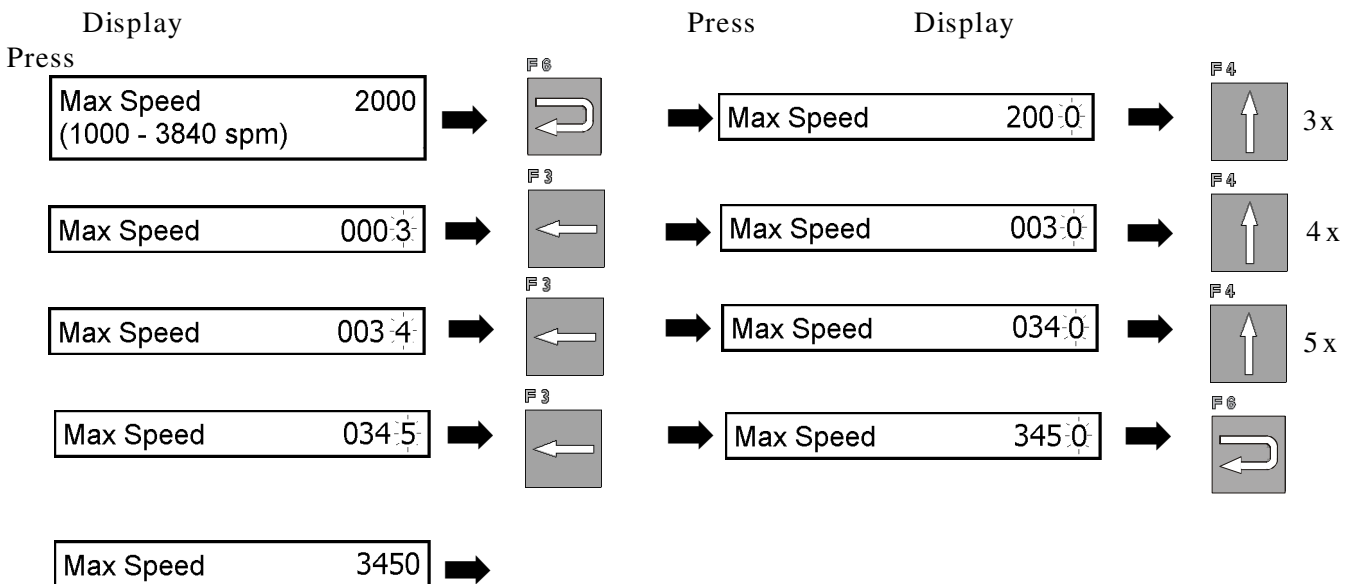

D - MACHINE CONTROLS

1. **Max speed** - maximal speed. Range *1000-3800* spm.
2. **Slow stitch** - selecting the number of stitches in slow start. Range *0-3*.
3. **Slow speed** - setting the slow start speed at the beginning of the sewing cycle. Range *500-1000* spm.
4. **Ndl Up pos** - correction of the needle bar upper position. Range *0 - 600* imp.
5. **D off delay** - draw-off delay. It is possible to set it in range *60-150* ms.
6. **D off tm** - timing of the knife/draw-off activation. It is possible to set it in range *30-200* ms.
7. **Trim delay** - setting the trim delay. It is possible to set it in range *0 - 200* ms.
8. **Trim time** - setting the trim timing activation. It is possible to set in range *30 - 60* ms.
9. **Clamp delay** - setting the clamp delay. It is possible to set in range *0-100* ms.
10. **Cycle delay** - setting the delay between the sewing cycles. Cycling parameter must be activated.
It is possible to set it in range *500-2500* ms.
11. **Cycling** - setting the machine cycling. It is possible to set *Yes / No*.
12. **Pedal** - setting the foot pedal position. Possible setting *1 step / 2 steps*.
13. **Double Sew** - setting the number of buttonhole repeat. It is possible to set *1, 2 = 1 or 2, 3 = 2*.
14. **L Count** - life counter
15. **Count Rst** - counter restart

To return to the main screen, press  key.

D - MACHINE CONTROLS

5. TESTS

WARNING! ONLY PROFESSIONAL SERVICE TECHNICIANS SHOULD PERFORM THESE TESTS!



The main screen appears on the display. Press  ,

Back - F2	Param - F3
Test - F4	Ver. - F5

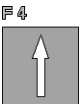
 appears on the display. To

enter the tests menu, press  key. The following screen appears on the display .

Input test	
Z Phase Pls	Off

 To scroll this menu down, press  key, to scroll this menu up, press 

key.

NOTE: Before performing the tests, press and release the Emergency Stop button to disconnect the motor.

INPUTS TESTS

1. **Low air pressure** - *Low air pressure off* appears on the display. If the air pressure is lower than 0,5 MPa, the message *Low air pressure on* appears on the display. The switch BQ 2 is tested by this parameter.
2. **Home sensor** - the end position sensor. *Home sensor off* appears on the display. Activate the sensor using a metal tool. *Home sensor on* appears on the display. Switch BQ1 is tested by this parameter.
3. **Voltage rly** - *Voltage rly off* appears on the display. If the power supply drops below 185 V, the *Voltage rly on* appears on the display. Only in case the relay VC 1 is installed.
4. **Pedal 1 step** - *Pedal 1 step off* appears on the display. When the foot pedal is pressed to its first position, the *Pedal 1 step on* appears on the display. Switch SB4 is tested by this parameter.
5. **Pedal 2 step** - *Pedal 2 step off* appears on the display. When the foot pedal is pressed to its second position, the *Pedal 2 step on* appears on the display. Switch SB5 is tested by this parameter.
6. **Em Stop** - after the Emergency Stop button is pressed, the *Em Stop off* appears on the display. After the Emergency Stop button is released, the *Em Stop on* appears on the display. Switch SA1 is tested by this parameter.
7. **Clamp Button** - *Clamps button off* appears on the display. When the clamp Up/Down button is pressed the *Clamp button on* appears on the display. Switch SB3 is tested by this parameter.
8. **Motor ready** - *Motor ready off* appears on the display (motor is off).
Motor ready on appears on the display (motor is on) servodrive U2 is tested B4 this parameter.

Revised 01/2009



e-mail: service@amfreece.cz; parts@amfreece.cz; website: www.amfreece.com

Phone: +420 582 309 146 (Service), +420 582 309 286 (Spare Parts); Fax: +420 582 360 606



D - MACHINE CONTROLS

OUTPUTS



The following parameters can be tested only in case the air supply is connected to the machine. After

pressing  key, Out put
Clamps Off appears on the display. To selected the line press  key used for change.

1. Clamps -

Clamps off appears on the display. When the  key is pressed, the clamp feet are activated and *clamps on* appears on display, to confirm the value press the  key and clamp feet are closed.

Lifting up the clamp feet:

press the  key, to change the valve press the  key and *clamp off*



appears on the display. To confirm the set values press the  key and the clamp feet are lifted up.

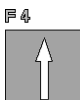

The valve YV2 is tested by this parameter.

2. D off -

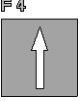
D off Off appears on the display. After pressing  the key *Off* is blinking and by pressing the  key tension is activated and *D off on* appears on the display. To confirm the set valve press this key. The valve YV1 is tested by this parameter.



3. Trim -

Trim off appears on the display. After pressing the  key the thread trim is activated and *trim on* appears on the display, by pressing the  button the set value is confirmed. The valve YV3 is tested by this parameter.



To return in tests press the  key, to finish the tests press the  key.

D - MACHINE CONTROLS

6. PROGRAM VERSION

Home screen appears on the display. Press ,  appears on the display. To

find out loaded program version into the machine. press the  key.

 appears on the display. Press again  key to return back to main screen.

D - MACHINE CONTROLS

7. PARAMETER CHECKLIST

PARAMETER	RANGE	SETTING
MAX SPEED	1000-3800 <i>szm</i>	3500
SLOW STITCH	0-3	0
SLOW SPEED	500-1000 <i>szm</i>	1000
NDL UP POS	0-600 <i>imp</i>	300 - 400
D OFF DELAY	60-150 <i>ms</i>	120
D OFF TIME	30-200 <i>ms</i>	100
TRIM DELAY	0-200 <i>ms</i>	150
TRIM TIME	30-60 <i>ms</i>	50
CLAMP DELAY	0-100 <i>ms</i>	50
CYCLE DELAY	500-2500 <i>ms</i>	500
CYCLING	yes/no	No
PEDAL	1 step / 2 steps	2 step
DOUBLE SEW	1, 2=1 or 2, 3 = 2	1

E - MACHINE ADJUSTMENTS

1. MACHINE HOME POSITION

1. The needle bar is in the upper position. The needle **1** descends to the right side of the throat plate slot **2** during the first stitch. The marks **3** on the handwheel and cover casting are aligned.
2. The clamp plate **3** with clamp feet **4** is in the full forward position against the adjustable stop **5**. The clamp plate moves to the rear during the first row of stitching.

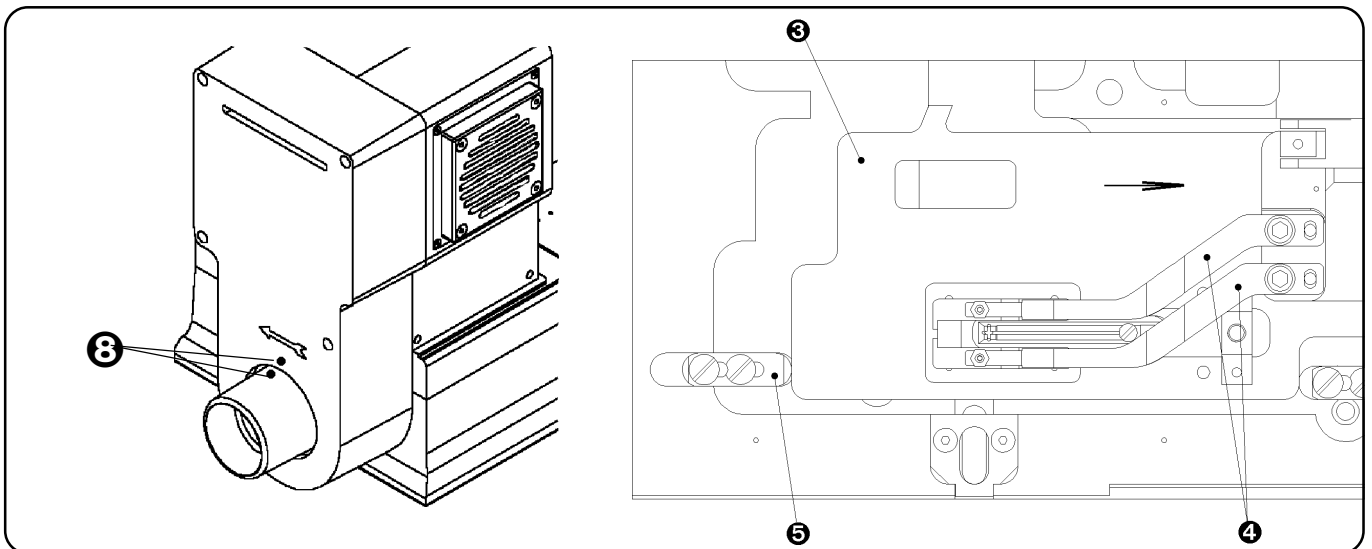
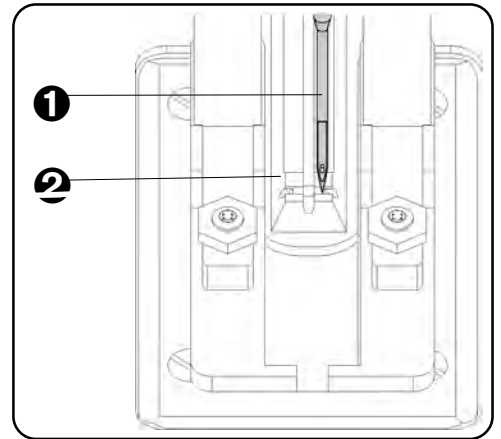

E - MACHINE ADJUSTMENTS

2. MAIN CAM ADJUSTMENT

1. Bring the machine to the home position.
2. Tilt the machine on the rest pin and view the main cam assembly. The distance between the control spring **6** and the right shifter block **7** is 2 mm.
3. If incorrect - see section E9, point 1.

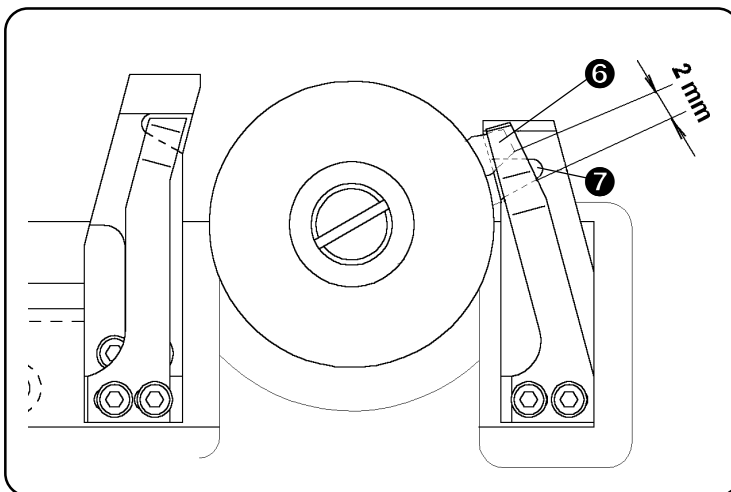

3. THE PRINCIPLES FOR THE MACHINE ADJUSTMENT

1. *Before making mechanical adjustments, the machine should be switched to the Service mode.* Press the Emergency stop button on the machine head, then release it

Ready - F1
Service - F6

appears on the display.

Then press the  **1** key (on control panel).

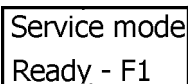
 appears on the display. Now is possible to make the mechanical adjustments with hand wheel.

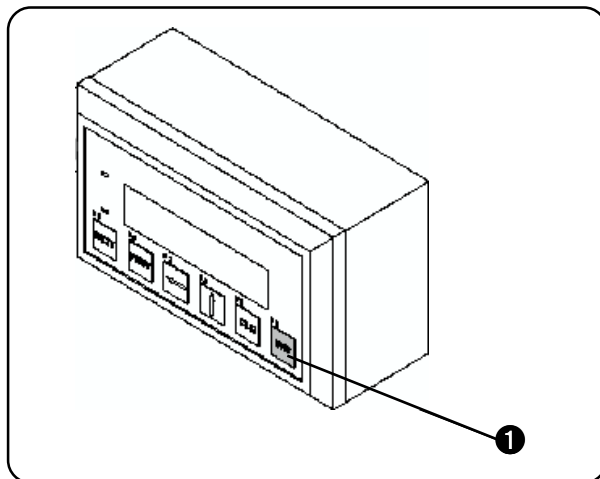

CAUTION: It is not possible to start sewing by pressing the foot pedal when working in Service Mode.

2. Press  **NEXT** key to return to the main screen.

E - MACHINE ADJUSTMENTS

4. NEEDLE BAR

1. *Needle bar crank position*

Turn the handwheel ⑤ and loosen the screw ① in the needle bar crank ②. Turn the handwheel until the needle bar reaches the upper position. Pulley screw ③ on the main shaft should be in the same line with screw ④. Tighten the screw ①.

NOTE: The needle bar should be in the top dead center position when the screw ③ is at 12 o'clock. To check, turn the handwheel clockwise and counter clockwise. The needle bar must move downward in either direction. The needle ⑩ makes its first stroke into the right side of the throat plate.

2. *The needle bar height adjustment*

Adjust the needle bar ⑥ height to 16 mm (5/8") from the surface of the throat plate ⑦ to the lower edge of the needle eye. Use height gauge ⑨.

Loosen the set screw ⑧ and move the needle bar up or down as necessary.

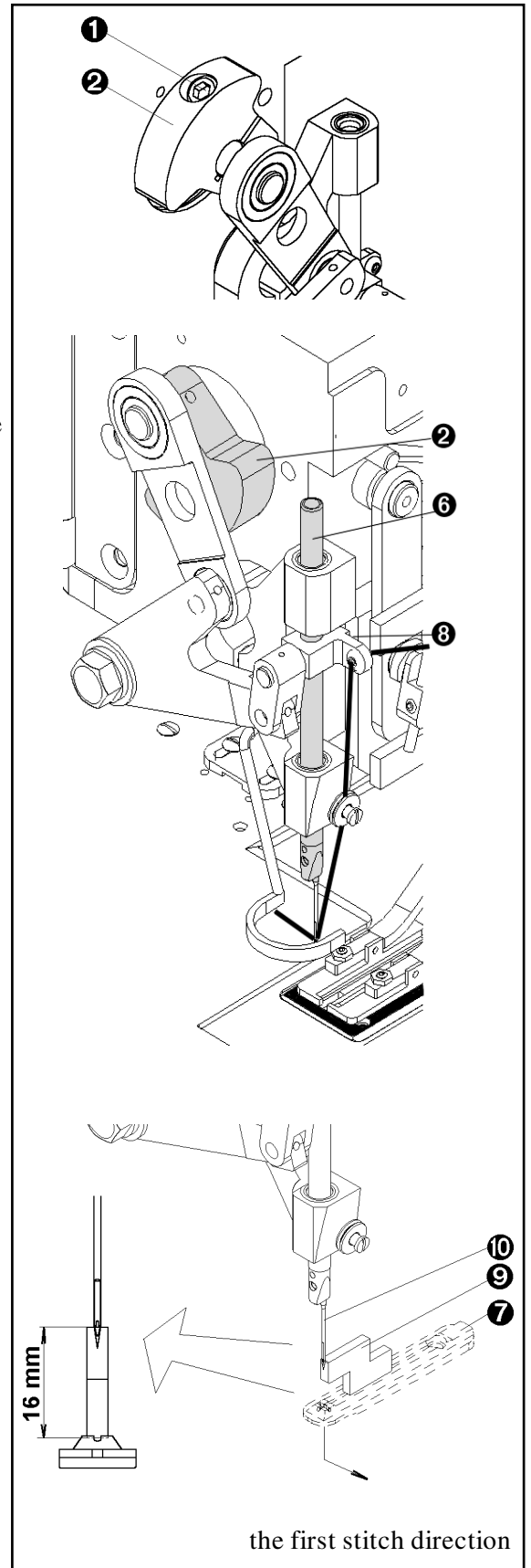
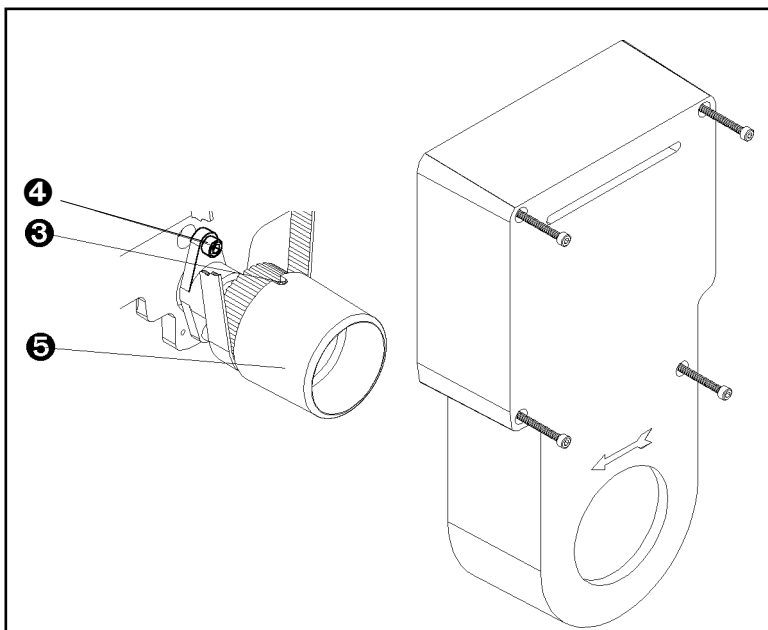

E - MACHINE ADJUSTMENTS

5. BITE

Before the bite adjustment, remove the pulley cover **2** and the head cover **1**.

1. *Bite cam*

- a) Check if the machine is in the home position.
- b) Tilt the machine on the rest pin **7**. If the adjustment is correct, the second cam locking screw **3** (counter clockwise of the bite cam **9**) must be roughly perpendicular to the bedplate casting.
- c) Adjust the position of the bite cam so that all of the needle bite motion occurs equally with the needle out of the work piece on the up and down stroke.

Note: There must be no bite movement before the needle **10** comes out of the work nor after it has descended into the work - see illustration. Tighten both locking screws **3** securely.

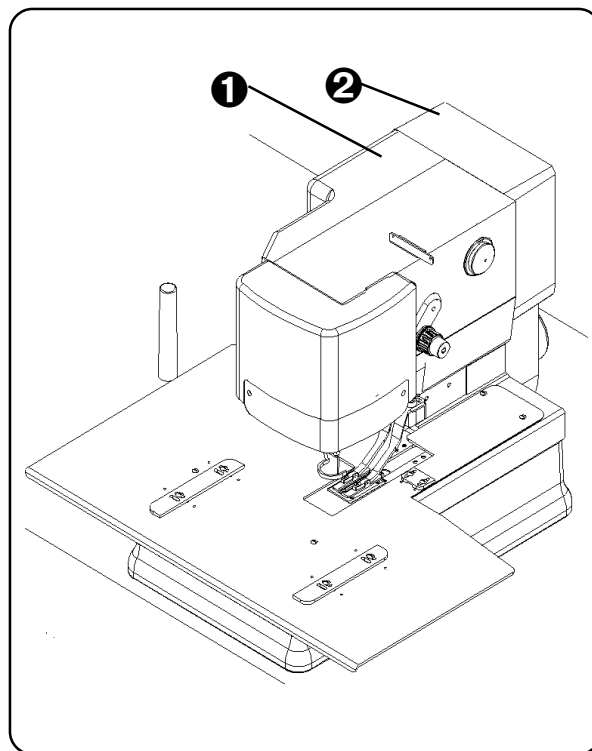

Needle upper position

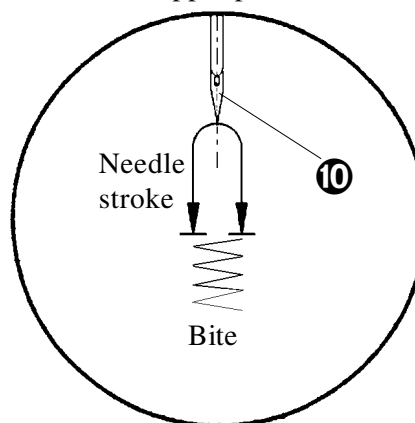

E - MACHINE ADJUSTMENTS

2. *Bite width adjustment*

To adjust the bite width, first remove the head cover for access to adjustments. The S-4000 ISBH is fitted with a regular bite throat plate **11**, that allows a bite range of 1.5 mm (1/16") to 2.3 mm (3/32").

- a) loosen the adjusting screw **12**
- b) to increase the bite width, raise the bite lever **13**
- c) to decrease the bite width, lower the bite lever **13**
- d) tighten the adjusting screw **12**

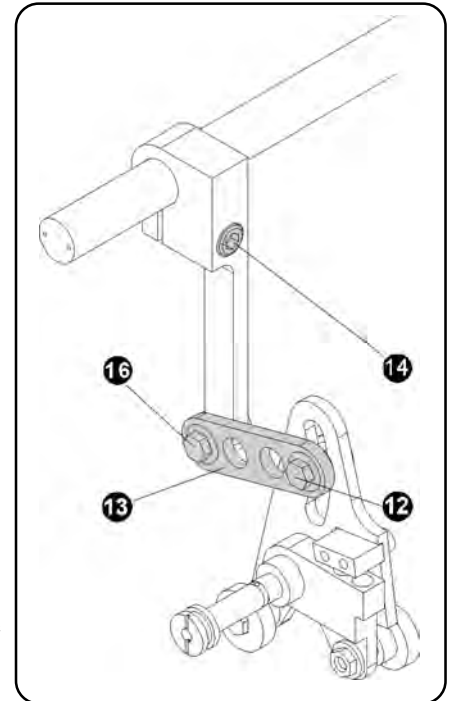

3. *Centering the bite over the throat plate*

- a) with the machine in the home position - loosen the clamping screw **14** on the bite lever **15**
- b) for rough adjustment, using the handwheel, rotate the needle bar to its full down position and move the needle to the right side of the throat plate slot **11**. Turn the hand wheel to the second needle **10** down stroke and compare the needle position in the left side of the throat plate. Continue adjusting until the needle is roughly of equal distance from the right and left sides.
- c) tighten the clamping screw **14**
- d) For finite adjustment loosen the screw **16** and rotate the eccentric nut **17**. Tighten the locking screw **15**.

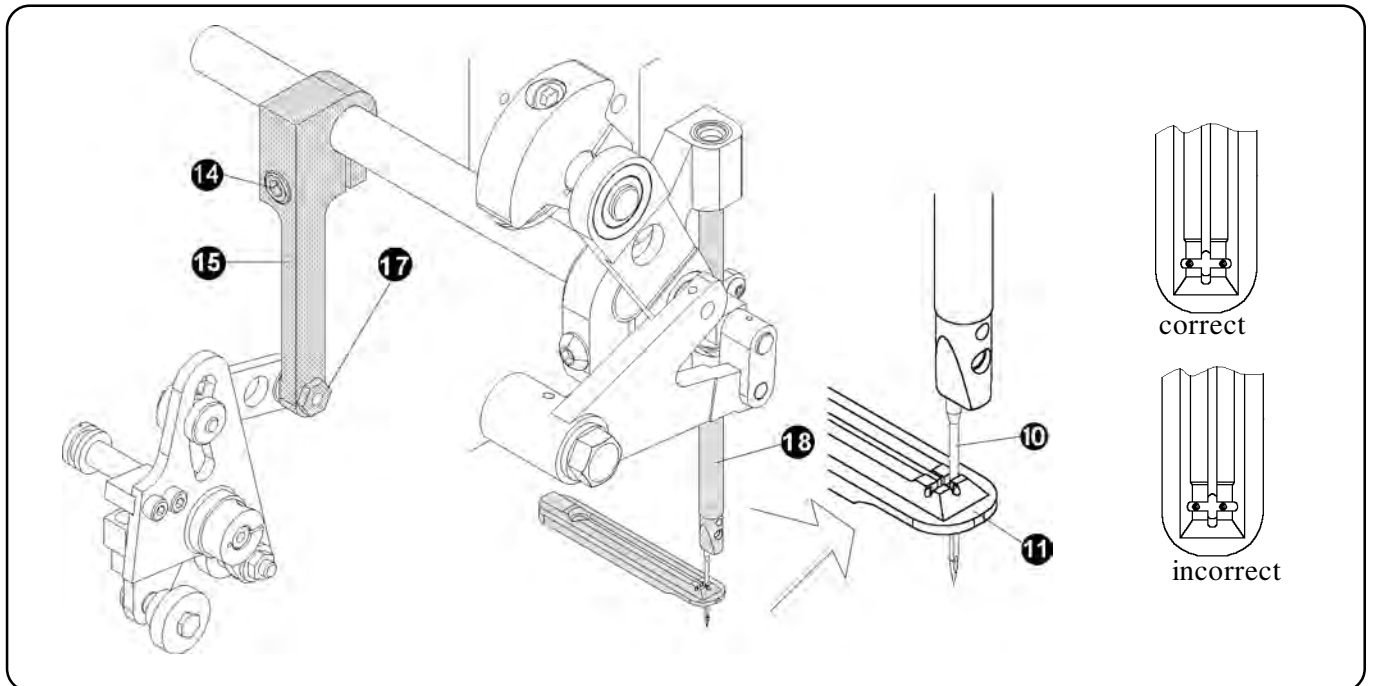

E - MACHINE ADJUSTMENTS

6. FEEDING

1. Tilt the sewing head on the rest pin.
2. **Bevel Gear Adjustment**
Manually turn the hand wheel counter clockwise, until the drive spring in the main cam engages with a detent (first row of stitches). Remove the bevel gear cover and loosen the screws **1**, **2** on the horizontal bevel gears and screw **3** on the stop.
3. Loosen two adjusting screws **4** in the right collar **5**.
Adjust the dimension 11mm from the end of the feed shaft **6** to the collar **7** by pressing the feed shaft **6** against the right collar **5**. Tighten the adjusting screws **4** in the right collar **5**. The tension of the left collar on the shaft is set.
4. Engage the left bevel gear **8** with the vertical bevel gear **9** and lock its position by set screws **2**. Move the stop against the gear and tighten set screw **3**.
5. Manually turn the hand wheel counter clockwise until the feed shifter lever moves to its full left position then slide the right gear **10** into engagement with the vertical gear **9**.
Tighten set screws **1** securely.

The bevel gear adjustment is done. By manually turning the handwheel finish the sewing cycle and bring the machine to the home position. Reinstall the bevel gear cover.

6. Clamp plate movement occurs only when the needlepoint has risen above the work piece and must be completed before the needle descends into the work.
7. For adjustment use a piece of paper to see the needle punctures.

If feeding occurs while the needle is in the work, engage the drive spring into a detent.

Loosen the screws **11** on the feed cam and adjust its position as needed so that all feed motion occurs with the needle out of the work. Retighten the feed cam set screws.

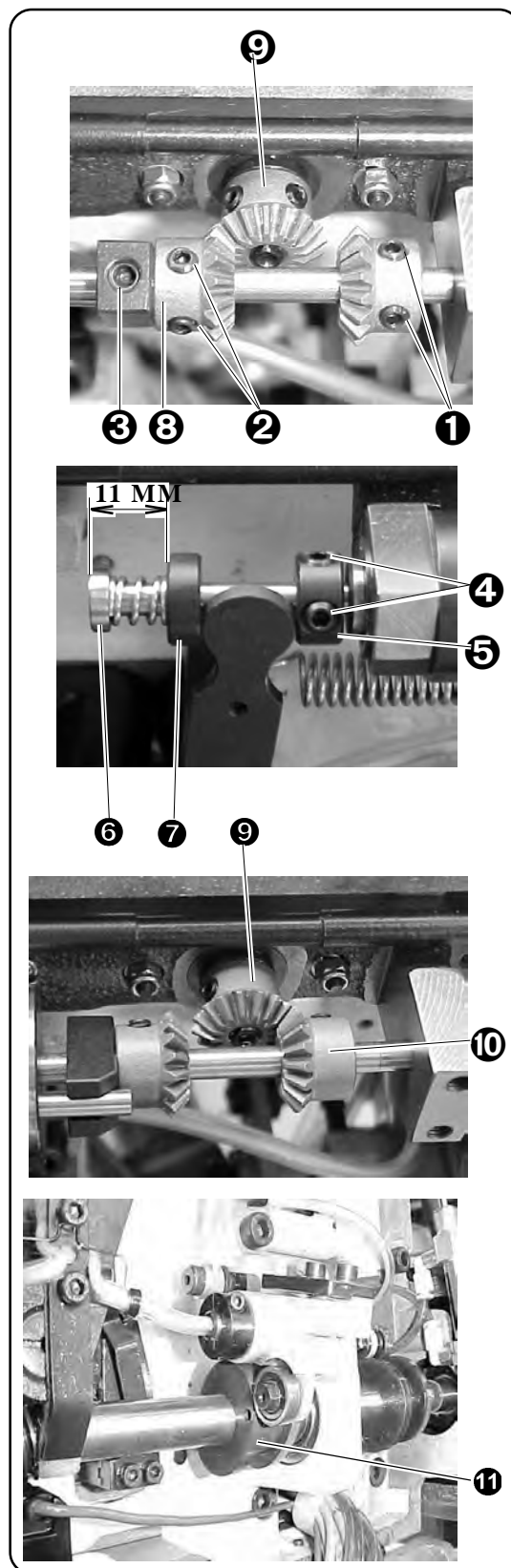

E - MACHINE ADJUSTMENTS

7. SLIP CLUTCH

The slip clutch pressure is factory set and under normal conditions will not need adjusting. The correct clutch torque setting is 0.43 Nm (60 to 65 inch ounces).

Hold the nut **1** and tighten the adjusting screws **2** with a torque screwdriver. Apply an equal amount of pressure to both sides of the clutch.

NOTE: If a torque screwdriver is not available, tighten the lock nuts so that the screws **2** extend through the nuts **1** 1.5 mm.

CAUTION: Too little torque will produce an improper material feed.
 Too much torque may damage parts (bevel gears).

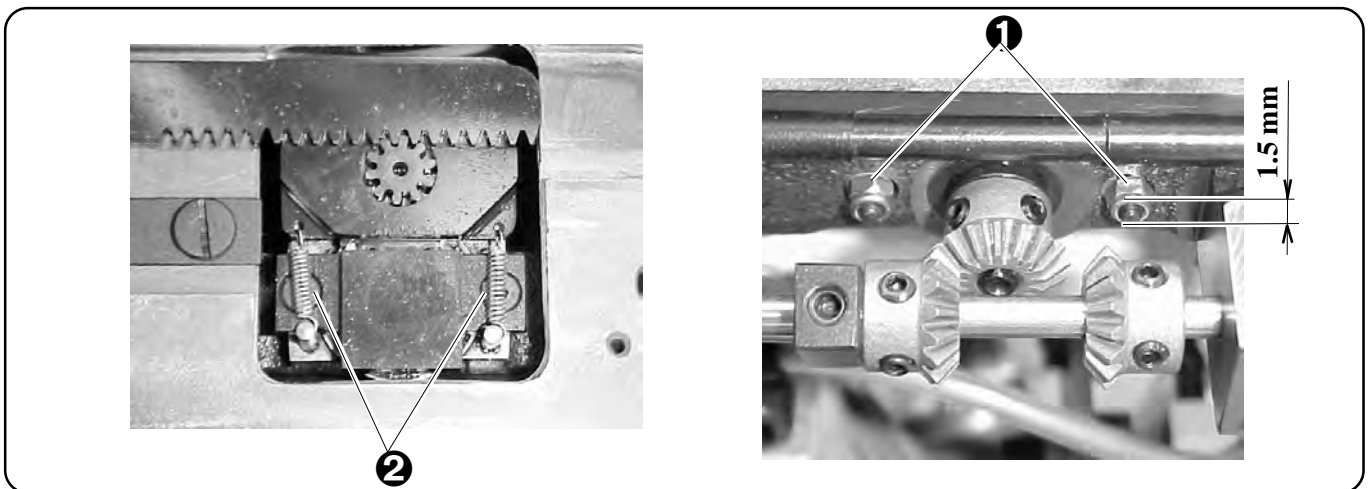

8. STITCH DENSITY

Adjust the feed connecting link position **1** in the cam follower slot **2** to obtain the correct stitch density.

To increase the density 1:

- a) Loosen the hex socket screw **3** and lower the link **1** away from the bedplate to increase density.
- b) Tighten the hex socket screw **3**.
 Maximum density is 12 stitches per 10 mm (30 stitches per inch).

To decrease the density 2:

- a) Loosen the hex socket screw **3** and raise the link **1** toward the bedplate to decrease density.
- b) Tighten the hex socket screw **3**.
 Minimum density is 4 stitches per 10 mm (10 stitches per inch).

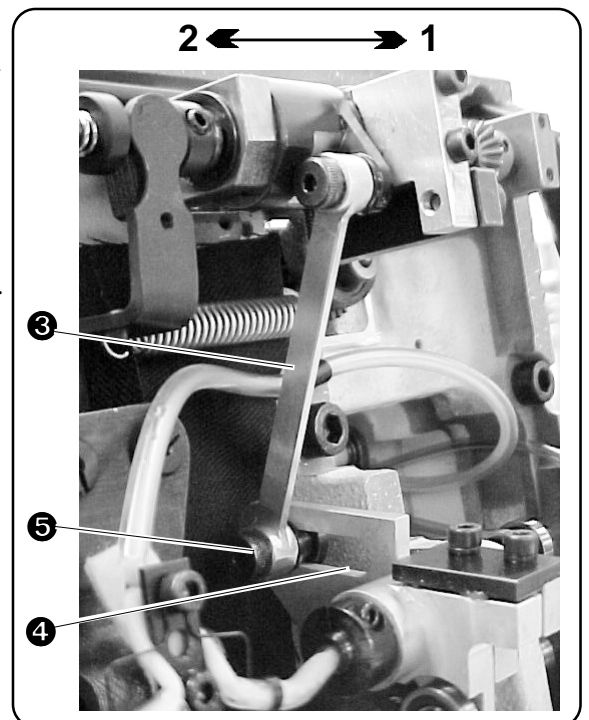

E - MACHINE ADJUSTMENTS

9. ADJUSTMENT OF BARRING STITCHES

To properly set the first bar **1**, the second bar **2** must be properly adjusted.

1. *Second bar adjustment*

Insert a piece of paper under the clamp feet. Turn the handwheel through the sewing cycle until the control spring **5** release the left shifter arm pocket **6**. Check to see that the clamp plate starts to move to the left just as the needle point rises from the work piece approximately 1 mm.

If the adjustment is incorrect:

a) *If the clamp plate moves when the needle is in the work*

- a1) loosen the screws **3** in the worm gear
- a2) hold the worm gear **4** by hand and turn the handwheel counter clockwise slightly
- a3) tighten the screws **3** and recheck the adjustment. Repeat as needed.

b) *The clamp plate moves when the needle tip is higher than 1 mm above the work surface*

- b1) loosen the screws **3** of the worm gear
- b2) hold the worm gear **4** by hand and turn the handwheel clockwise
- b3) tighten the screws **3** and recheck the adjustment. Repeat as needed.

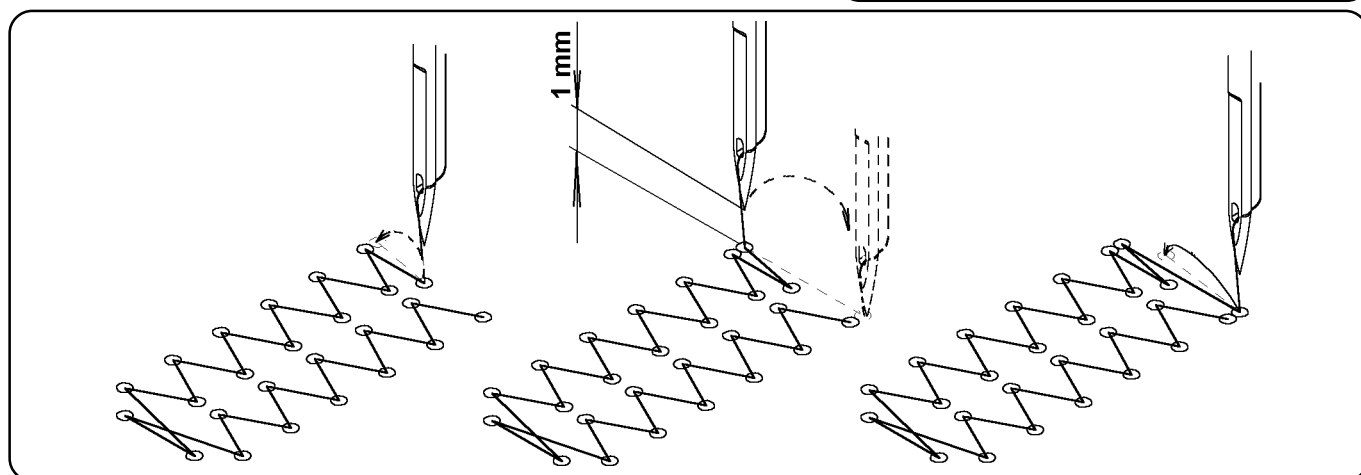
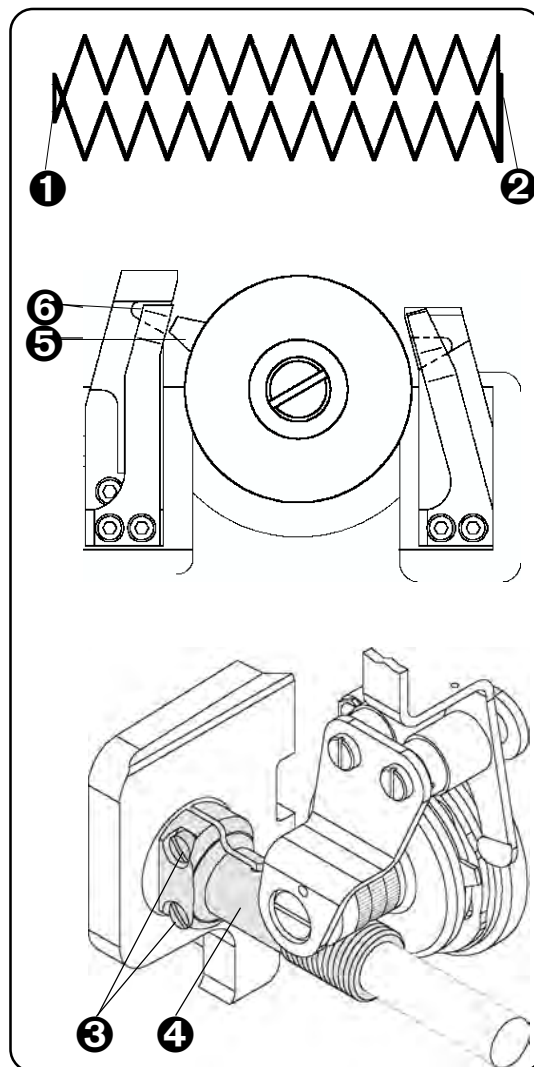

E - MACHINE ADJUSTMENTS

2. First bar adjustments

Turn the handwheel until the control spring engages into a detent. Check the distance 1-2 mm between the control spring and the shifter arm. If the distance is different, move the shifter arm after which is locked by two M4 screws ⑤.

Check the quality of the sewn buttonhole on the paper. If the stitches are uneven ⑥ follow below described adjustment:

Loosen the nut ⑦ and turn the nut ⑧ clockwise. This adjustment will provide the even stitches ⑨ in the first bar.

If the length of the buttonholes ⑩ is not the same, adjust the brake.

NOTE: If the spring tension on the brake is too strong, the stitch density in the bar may be increased.

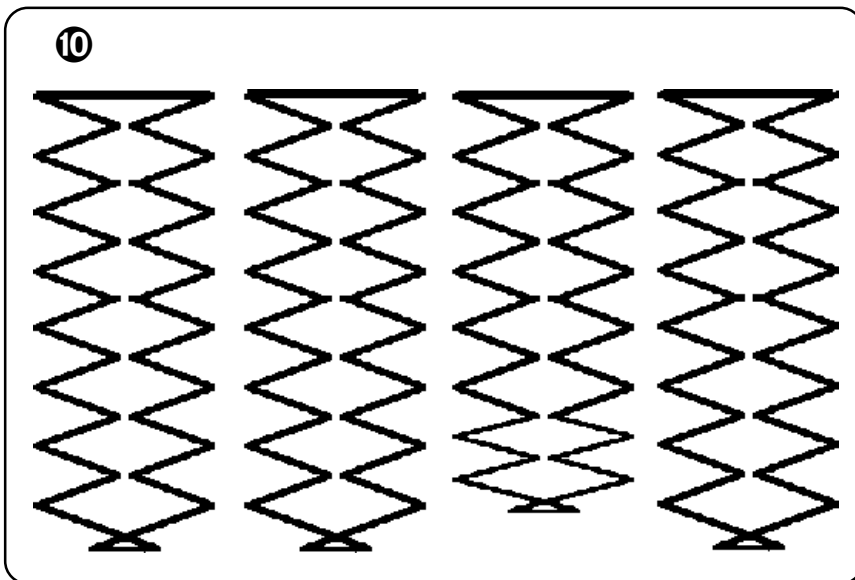
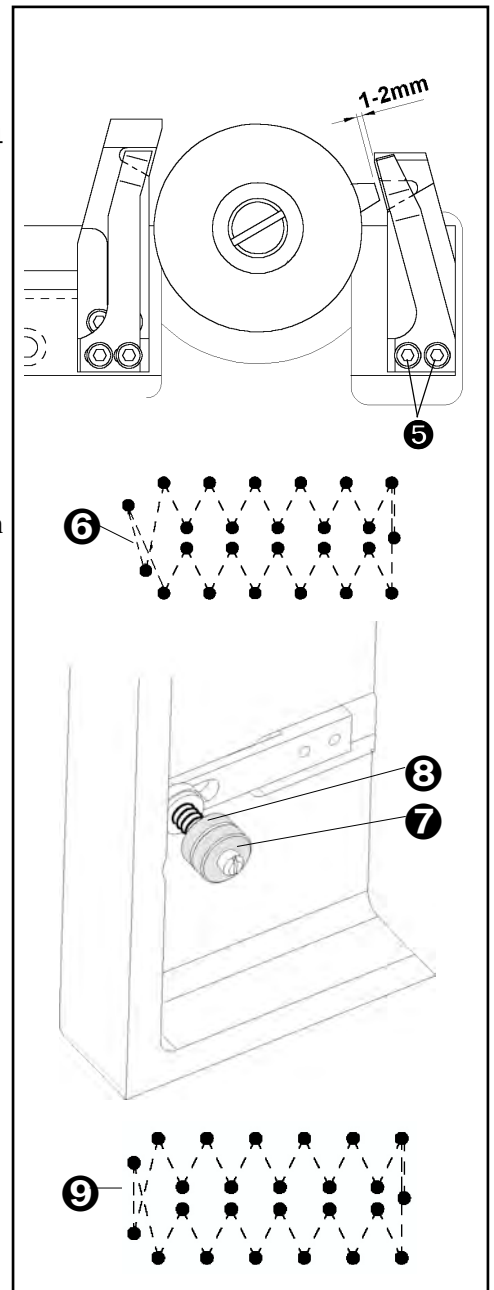

E - MACHINE ADJUSTMENTS

3. The clearance adjustment on the cam during the first bar sewing

- Turn the handwheel until the control engages into the detent of the left shifter arm
- Continue turning the handwheel. The main cam assembly ① starts turning and moving the rod ⑫.
- Check the minimal clearance by hand on the rod ⑫ when the control spring is not engaged with shifter arm.
- Check the rod tension when the control spring leaves the detento of the right shifter. The clearance must approximately be the same. If incorrect:
 - Slightly loosen M4 screw ⑬ and turn the eccentric ⑭ (clockwise - clearance decreases, anti-clockwise - clearance increases).
- Tighten M4 screw after adjustment and check the clearance in both positions.

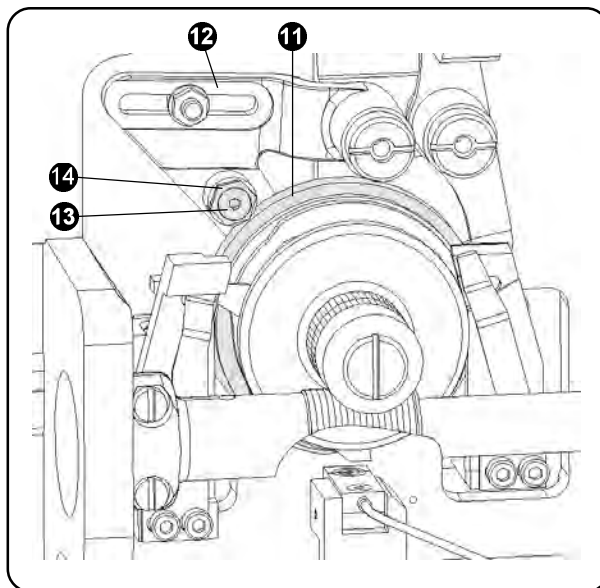

10. SPACE BETWEEN THE FIRST AND SECOND ROW OF STITCHES

- Tilt the sewing head on the rest pin.
- Loosen the nut ① and move the stud ② to the required position (to the right - space ③ decreases, to the left - space increases). The space can be adjusted in range 0 - 0.9 mm.
- Sew buttonhole on scrap fabric to check setting.

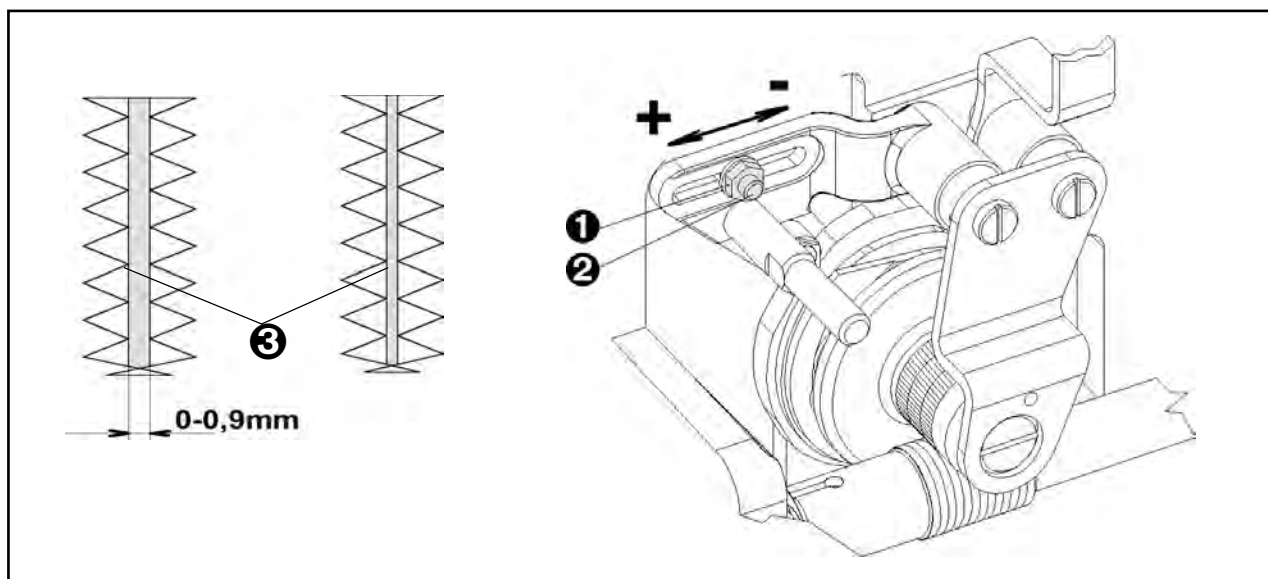

E - MACHINE ADJUSTMENTS

11. BUTTONHOLE LENGTH CHANGE

To change the sewn buttonhole length, remove the 7 screws **3** and the cover plate **4**.

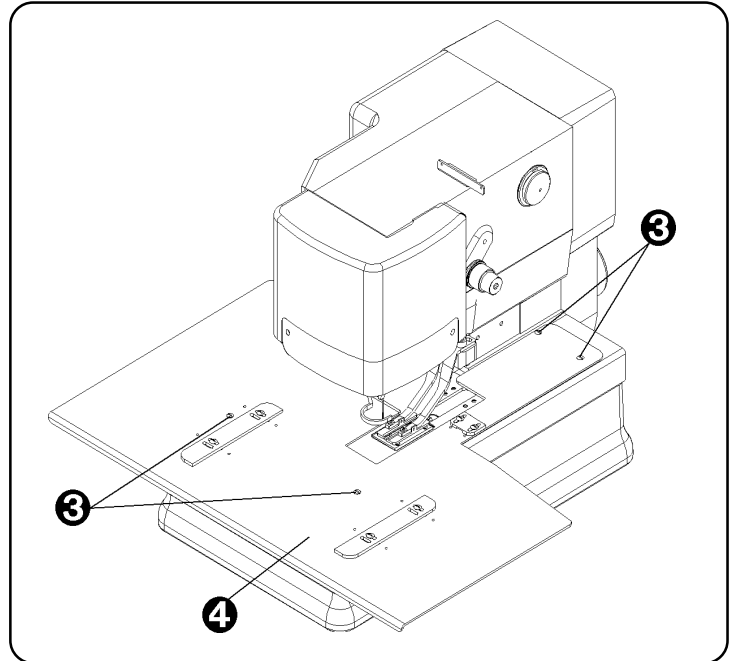

1. Loosen the screw **5** and move the stop **6** as needed. To the right - the buttonhole is shortened, to the left - the buttonhole is extended. The length can be set in range 15,8 - 25 mm (0.62 - 0.98").
2. Loosen the 2 screws **7** and slide the stop **3** temporarily forward (away from the clamp plate).
 the cover plate **4**. Sew two sample buttonholes on paper and measure their length.
3. Reinstall the cover plate **4** again and move the front stop **3** against the edge of the clamp plate **9**.
4. Install the cover plate **4**. The machine is ready for sewing with the changed buttonhole length.

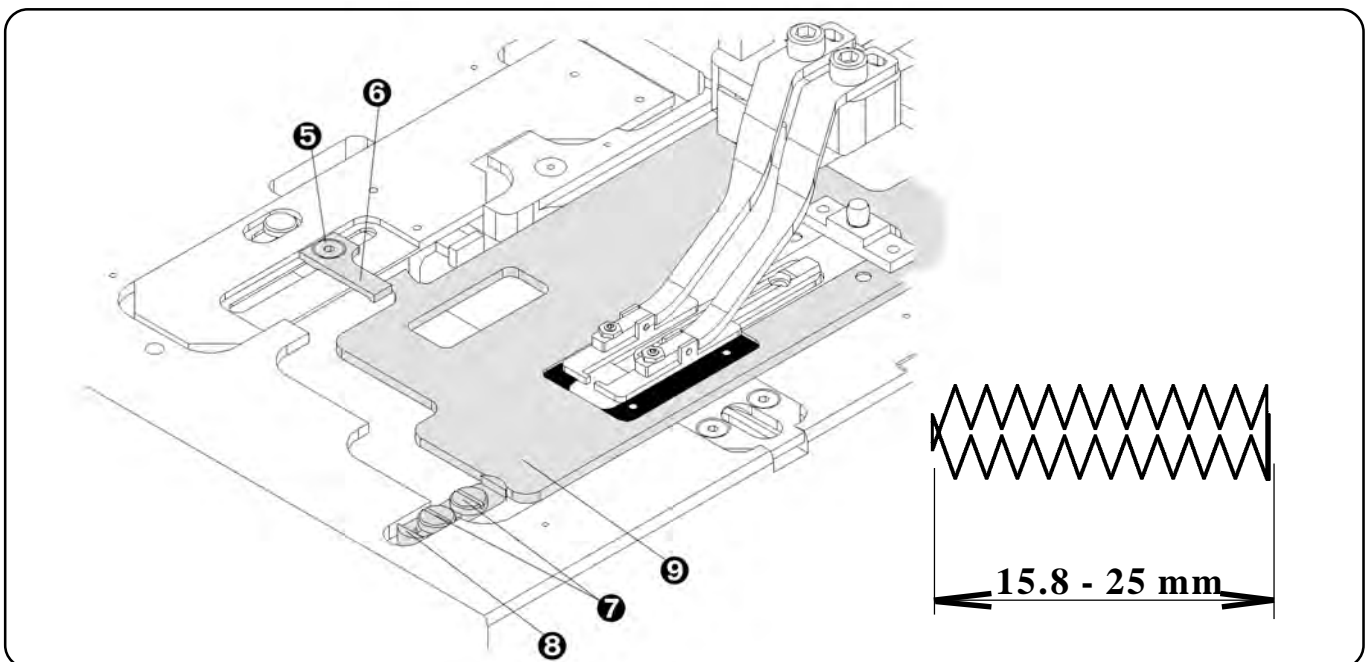

Revised 01/2009

e-mail: service@amfreece.cz; parts@amfreece.cz; website: www.amfreece.com

Phone: +420 582 309 146 (Service), +420 582 309 286 (Spare Parts); Fax: +420 582 360 606

E - MACHINE ADJUSTMENTS

12. LOOPER ADJUSTMENT

Before making this adjustment, follow the below described points:

- Turn the handwheel and observe the position of the connecting link **1** at both ends of the looper link arm travel **2**. Angle A **3** must equal angle B **4**.
- If incorrect - loosen the hex mounting screw **5** and rotate the eccentric adjusting nut **6** as needed. Tighten the hex mounting screw **5**.
- Turn the handwheel and bring the needle bar to the upper position.
- Check if the needle is straight.
- Tilt the machine head on the rest pin and check if the mark **7** on the looper cam **8** is on the left side. If the mark is on the right side, remove it and install it correctly. Return the sewing head back.
- Remove the cover plate **9**, disconnect the air tubes from the clamp feet cylinder and remove the clamping assembly **10** from the machine, remove the throat plate **11**, trimming hook cover **12** and trimming hook. Dismantle the loopers with holders.

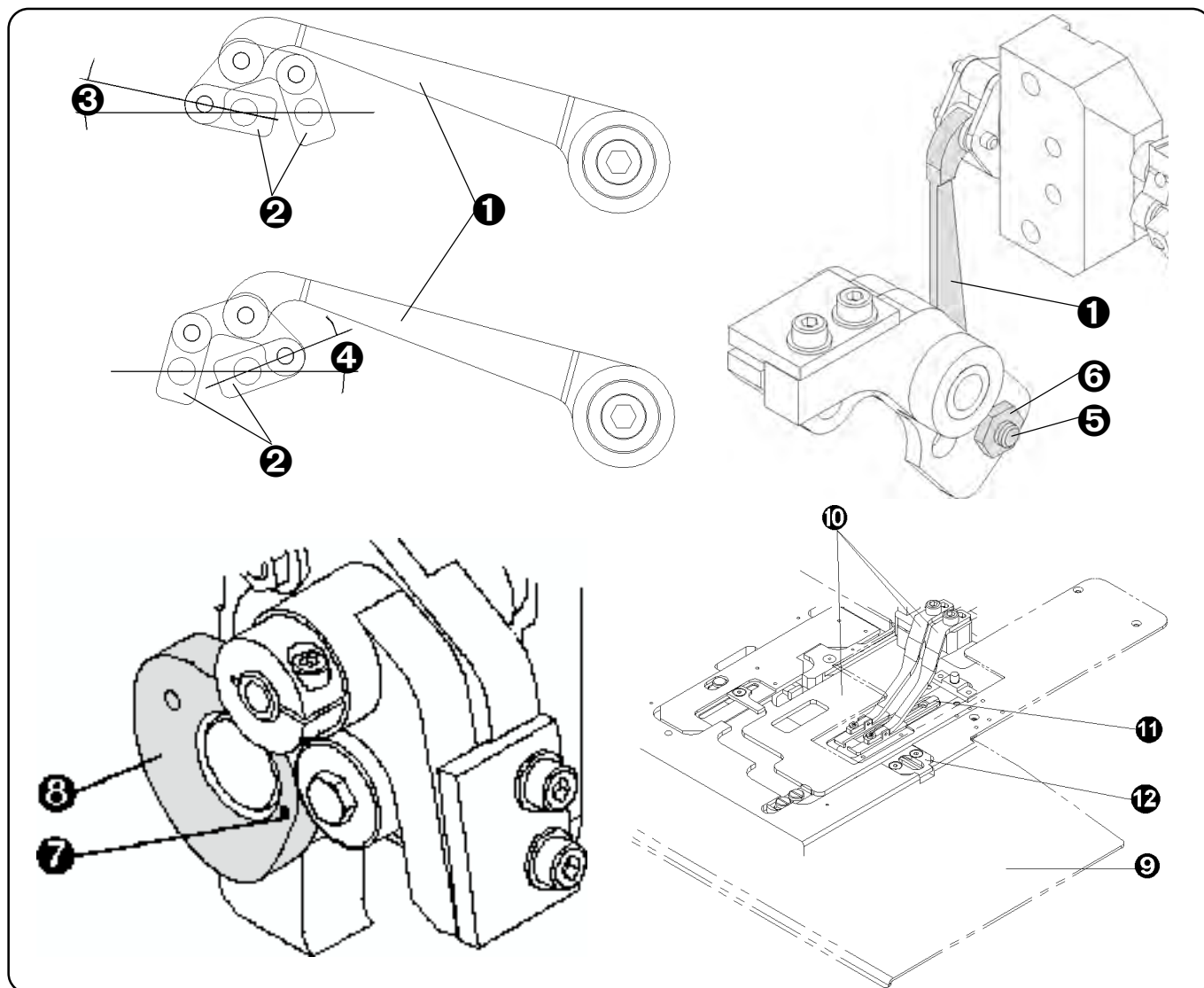

E - MACHINE ADJUSTMENTS

The first looper adjustment

1. Bring the machine to the home position and loosen the screws **13** of the looper cam **8** and adjust the looper cam to the lowest position.
2. Loosen the looper set screw **15** and turn the looper to be perpendicular to the hole in the looper holder.
3. Install the holder with the first looper **14** on the shaft.
4. Loosen the looper holder screw **16** and move the holder so that the needle passes the looper in the center of the looper recess. There must be clearance 0,4 mm between the needle and the looper recess. Tighten the looper holder screw **16**.
5. Loosen the looper screw **15** and turn the looper **14** to the needle to obtain the distance 0,1 mm between the needle and the looper tip.
6. Turn the hand wheel counter clockwise and insert the gauge **17** with 1 mark (wider side of the gauge) between the needle bar holder and the needle bar clamp when the needle returns to the home position from the lower position.
7. Check to determine if the tip of the looper is at the centerline of the needle 1 mm above the needles eye.
8. If incorrect - loosen the looper cam screw **13** by the wrench and hold it . Turn the hand wheel (counter clockwise - if the looper tip is higher than 1 mm; clockwise - if less than 1 mm). Tighten both looper cam screws **13** securely.
9. If it is necessary to adjust the looper cam again, check the clearance 0,4 mm between the needle and the looper recess.

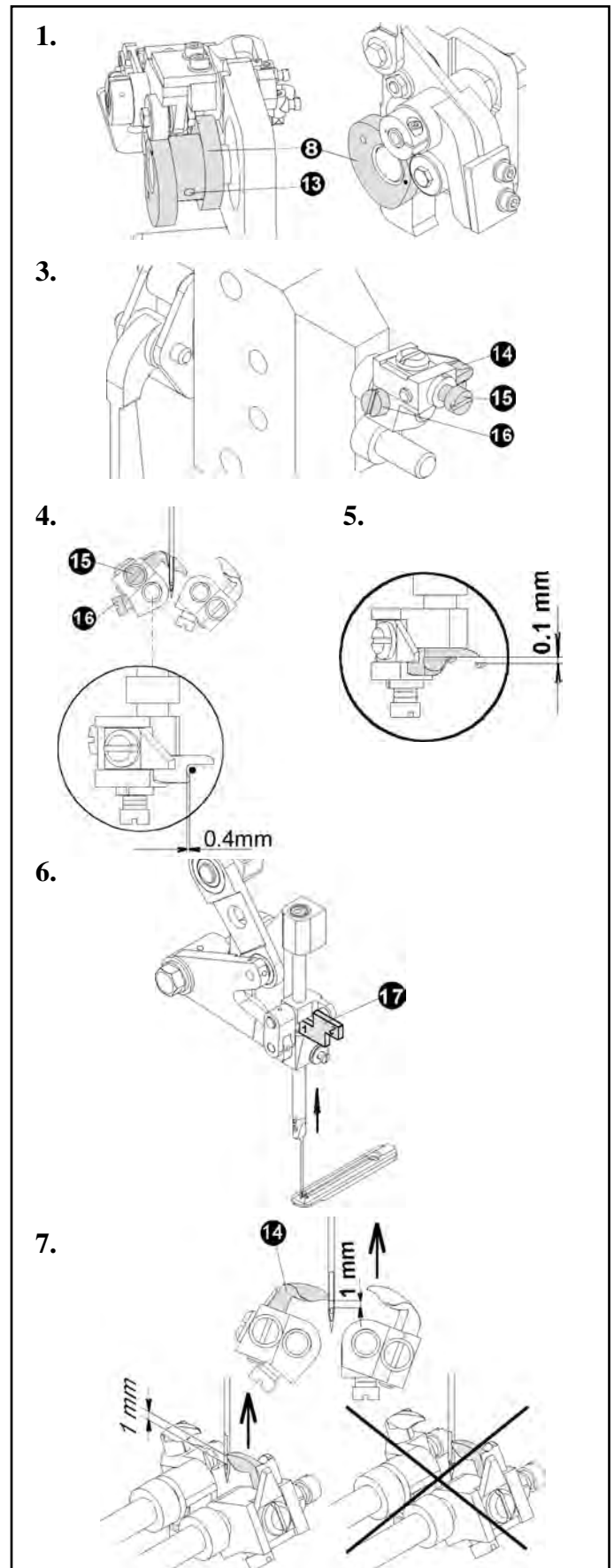

E - MACHINE ADJUSTMENTS

The second looper adjustment

10. Insert the second looper **18** on the looper shaft.
11. Loosen the looper holder screw **19** and move the holder so that the needle passes the center of the looper recess. There must be clearance 0,4 mm between the needle and the looper recess. Tighten the looper holder screw.
12. Loosen the looper screw **20** and turn the looper **18** to the needle to obtain the distance 0,1 mm between the needle and the looper tip.
13. Turn the handwheel counter clockwise, insert gage **17** with mark 2 (narrower side of the gage) between the needle bar holder and needle bar clamp.
14. Check if the looper tip crosses the axis of the needle 1 mm above the needle eye.
15. If it is necessary to adjust the looper cam again, check the first looper adjustment.

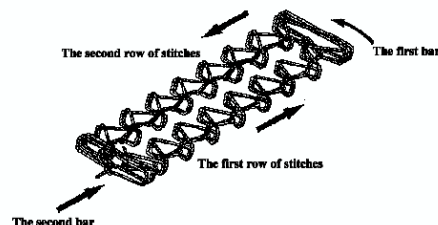
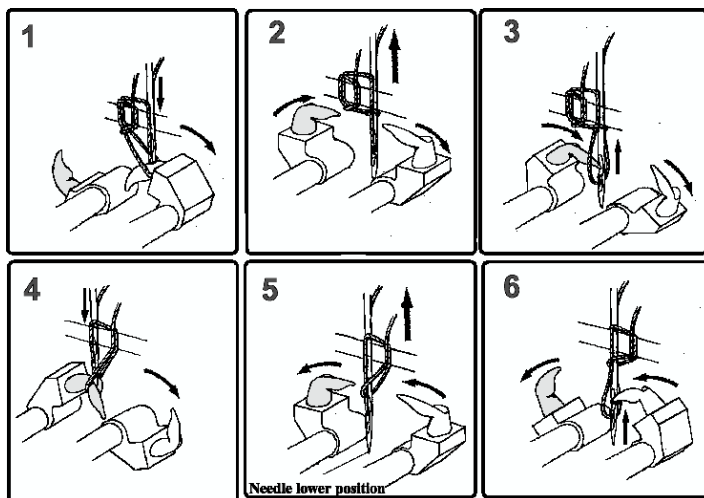
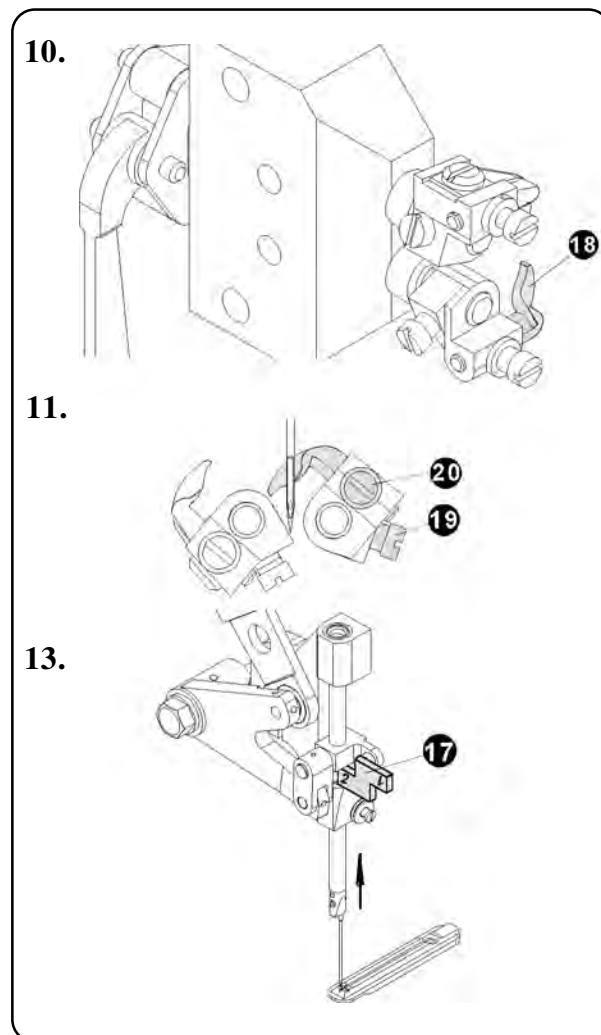

E - MACHINE ADJUSTMENTS

13. THREAD DRAW-OFF

1. *Adjustment of the Draw-Off Lever Position*

The correct adjustment ensures a long enough thread tail for starting the sewing of the next buttonhole. Remove the covers because this mechanism adjustment is performed in the rear of the head. Air supply is necessary for this adjustment.

- a) loosen the screw **6**
- b) the piston **7** of the cylinder **8** is in the home position (retracted). Move the lever **9** to the pin **10** with minimal clearance 0.1 mm. Tighten the screw **6**
- c) check the correct clearance adjustment by switching the valve **11** of the draw-off cylinder (YV1).

2. *The thread end adjustment*

If the first stitches are missing or the buttonhole is not sewn, follow the below mentioned steps:

- a) loosen the screw **1**.
- b) turn the draw-off lever **2** counter clockwise to increase the thread tail length; turn the draw-off lever clockwise to decrease the thread tail length

3. *Locking the stitches*

If the skipped stitches problem appears during the sewing, follow the below mentioned steps:

- a) loosen the screw **3**
- b) move the thread take-up **4** to increase the size of the needle loop

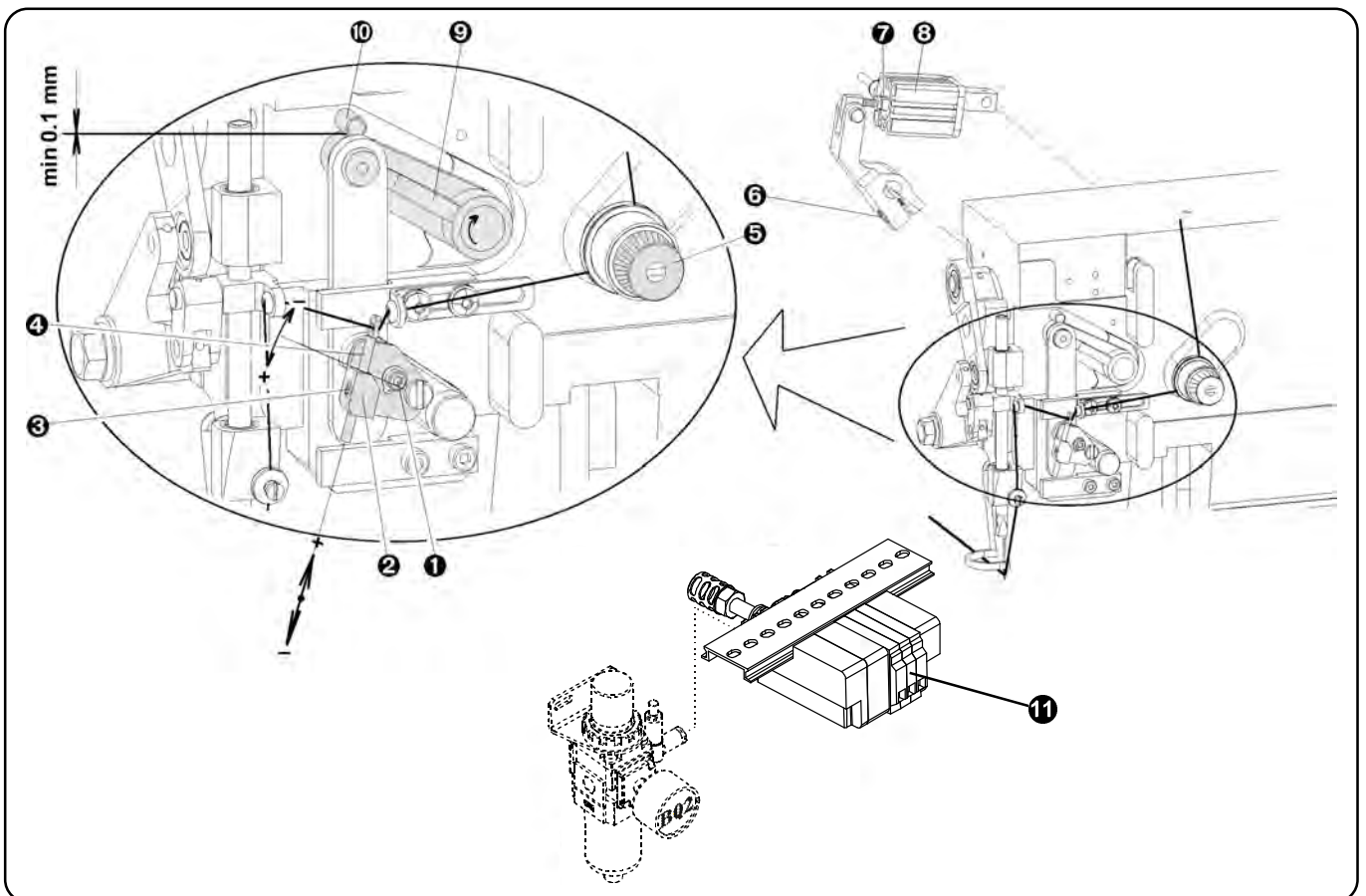

E - MACHINE ADJUSTMENTS

14. THREAD TENSION

The thread tension influences the appearance of the buttonhole. A thread tension change may be needed if the thread and fabric change. Check to be certain all parts, which contact the thread, are smooth and polished with no burrs or sharp edges.

- By turning the tension knob **1** clockwise, the thread tension increases.
- By turning the tension knob **1** anti-clockwise, the thread tension decreases.

NOTE: Too big thread tension can cause the unsightly appearance of the buttonhole when sewing on a thin and elastic material.

1. *Adjustment of the tension discs opening*

The opening of the tension discs is performed when the second bar is sewn. When the tension discs are opened, it is possible:

- a) to pull the thread from the spool when the draw-off lever **2** receives the impulse for operation
- b) by decreasing or increasing of the air flow it is possible to regulate the tightening of the last loop in the sewn buttonhole

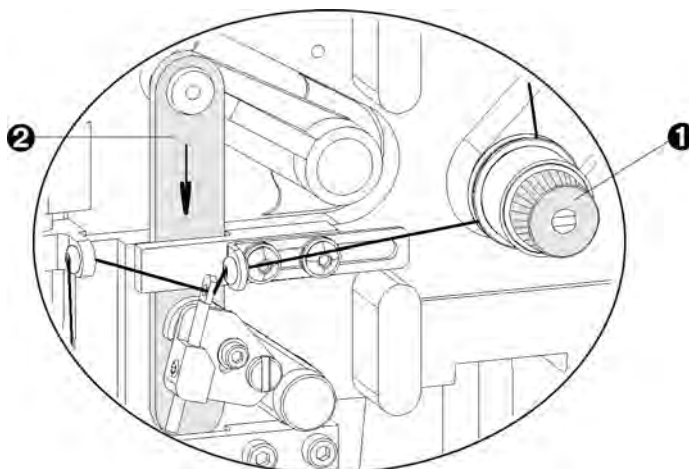

E - MACHINE ADJUSTMENTS

2. *The correct position of the tension mechanism*

- a) remove the tension assembly ③ from the shaft ④
- b) check if the distance between the stud slot edge and the pin ⑤ is 3.5 mm. If incorrect, it is necessary to adjust the position on the pin.
- c) remove the pulley cover and the head cover to obtain a good access for this adjustment. Switch off the air supply.
- d) disconnect the air tube ⑥ from the cylinder.
- e) loosen the nut ⑦ and turn the cylinder ③ as necessary. Turning clockwise the pin is extended. Tighten the nut ⑦ when the correct measurement is obtained.
- f) connect the air tube ⑥ to the cylinder, open the air supply and install the covers.

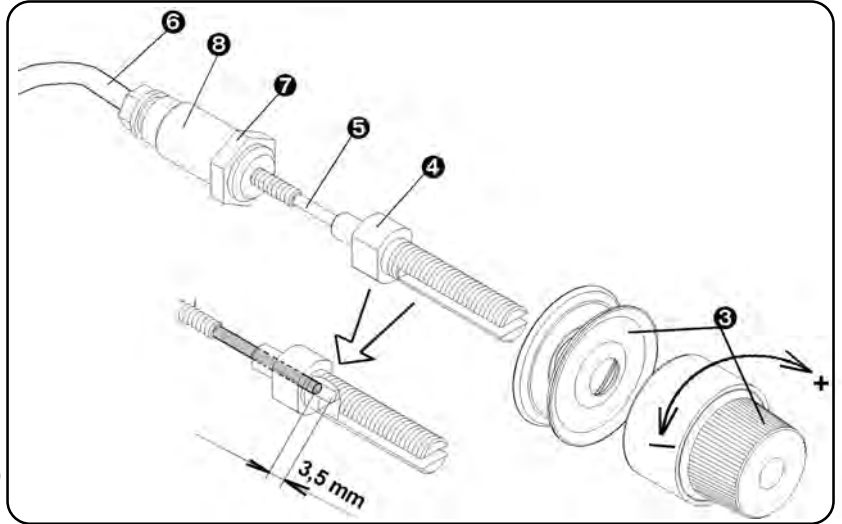

3. *Regulation of the tension discs opening*

If the last stitch is not tightened, follow the below mentioned steps:

- a) loosen the locking nut ⑨ on the speed controller ⑩
- b) To obtain better tightening of the last stitch, tighten screw ⑪ and lock the nut ⑨ securely.

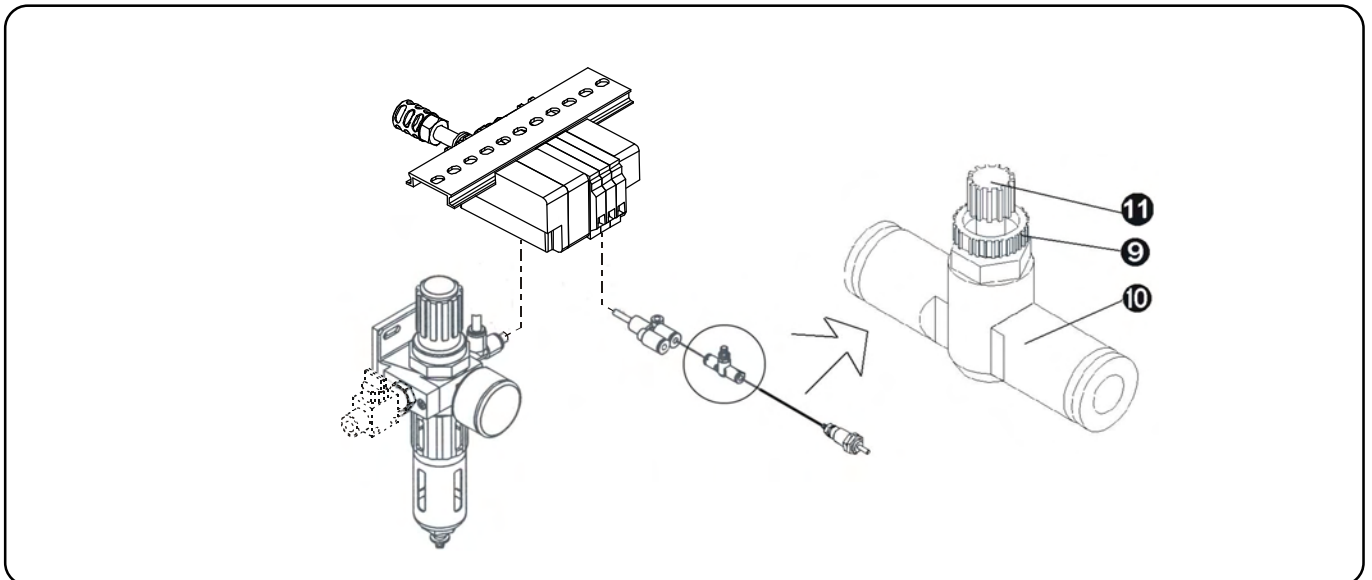

E - MACHINE ADJUSTMENTS

15. THREAD TRIMMING

Trimming mechanism ensures the correct thread trimming after sewing the last stitch. At the trimming hook moves in the direction of arrow, both thread loop legs A and B are pulled forward. When the thread hook approaches the end of the stroke, leg A contacts the trimming knife, cutting the thread.

1. *Trimming cylinder adjustment*

- tilt the machine head on the rest pin and close the air supply. Extend the piston **1** of the cylinder **2** to the maximum position.
- check to be certain that the cylinder does not push the lever **3** too high and into contact with the bedplate casting **4**. If no clearance exists, adjust as described in c, d, and e below:
 - loosen the screw **6**
 - to obtain the correct position of the lever **3**, loosen the nut **5** and turn the cylinder piston **1** in or out as needed
 - tighten the nut **5** and the screw **6**. After this adjustment check if no axial clearance exists on the shaft **7**.
 - if the axial clearance exists on the shaft, loosen the screw **6**, move the shaft **7** to the left so that the locking ring **3** touches the recess in the plate **3**. Move the lever to the right and tighten the screw **6**.

2. *The trimming hook **11** adjustment*

- push the piston **1** of the trimming cylinder **2** to the maximal position and loosen the screw **9** of the trimming actuator **10**.
- turn the trimming actuator **10** and set the clearance 1.0 mm between the throat plate and the point of the trimming hook.
- tighten the screw **9** of the trimming actuator **10**.
- open the air supply and check by switching the valve of the trimming cylinder if the actuator **10** does not hit the bedplate casting.

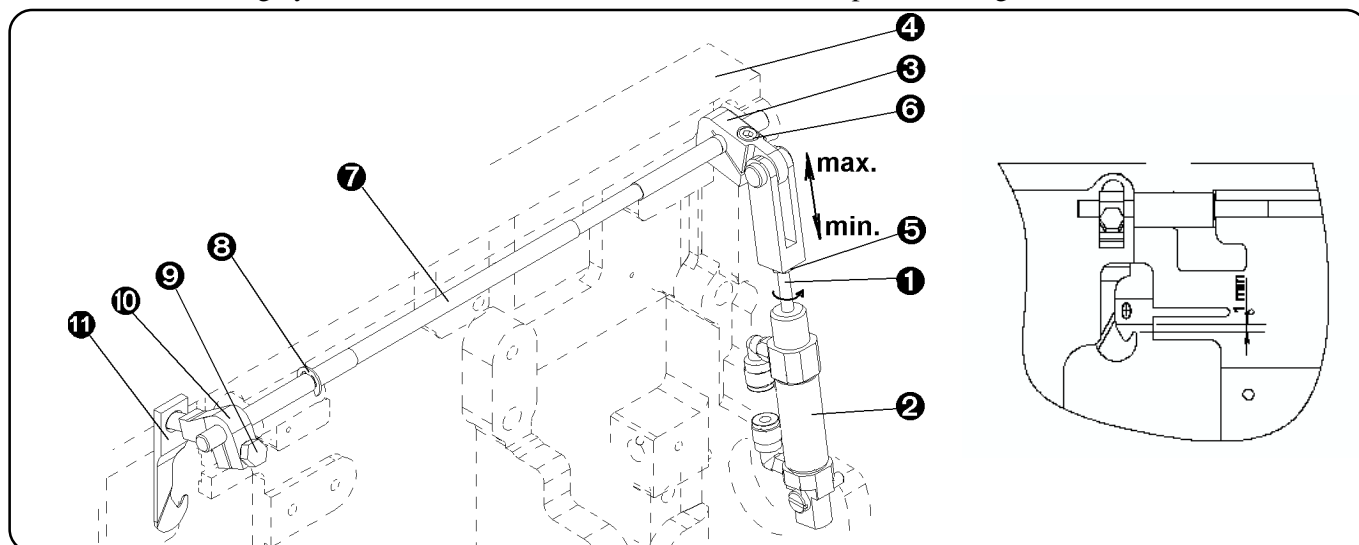
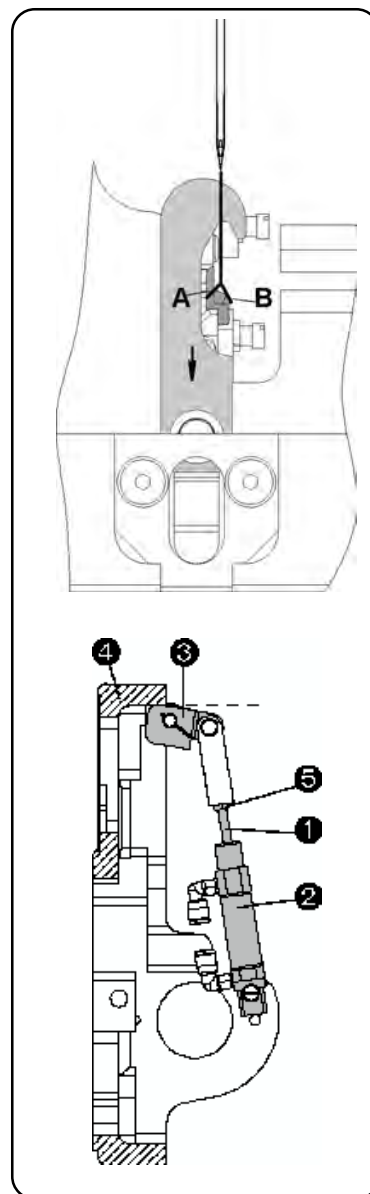

E - MACHINE ADJUSTMENTS

16. MACHINE HEAD CLAMP FEET ADJUSTMENT

1. *Adjustment for clamp height*

Be sure that air supply is switch on and the clamp feet are opened. If clamp feet are not opened, push the clamp Up / Down button.

- a) loosen the nut ❶
- b) turning the screw ❷ clockwise lowers the clamp feet mechanism ❸ to clamp mat ❹.
- c) tighten the nut ❶

NOTE: Correct height is when the underside of the clamp feet are slightly lower than the point of the needle in the home position.

2. *Adjustment of the distance between the clamp feet*

Be sure that the clamp feet are closed. If clamp feet are not closed, push the clamp Up / Down button.

- a) turn the handwheel to be sure that needle does not hit the clamp feet ❸. If it hits:
- b) push the clamp up/down button to open the clamp feet
- c) loosen the screw ❺ and get the clamp feet arm further from the needle and tighten the screw ❺
- d) to check this adjustmet, turn the handwheel when the clamp feet are closed. The needle must not hit the clamp feet.

NOTE: Keep minimal distance between the needle bar and the clamp feet during this adjustment. Too big distance of the clamp feet can cause the missing stitches when sewing on thin and elastic fabrics.

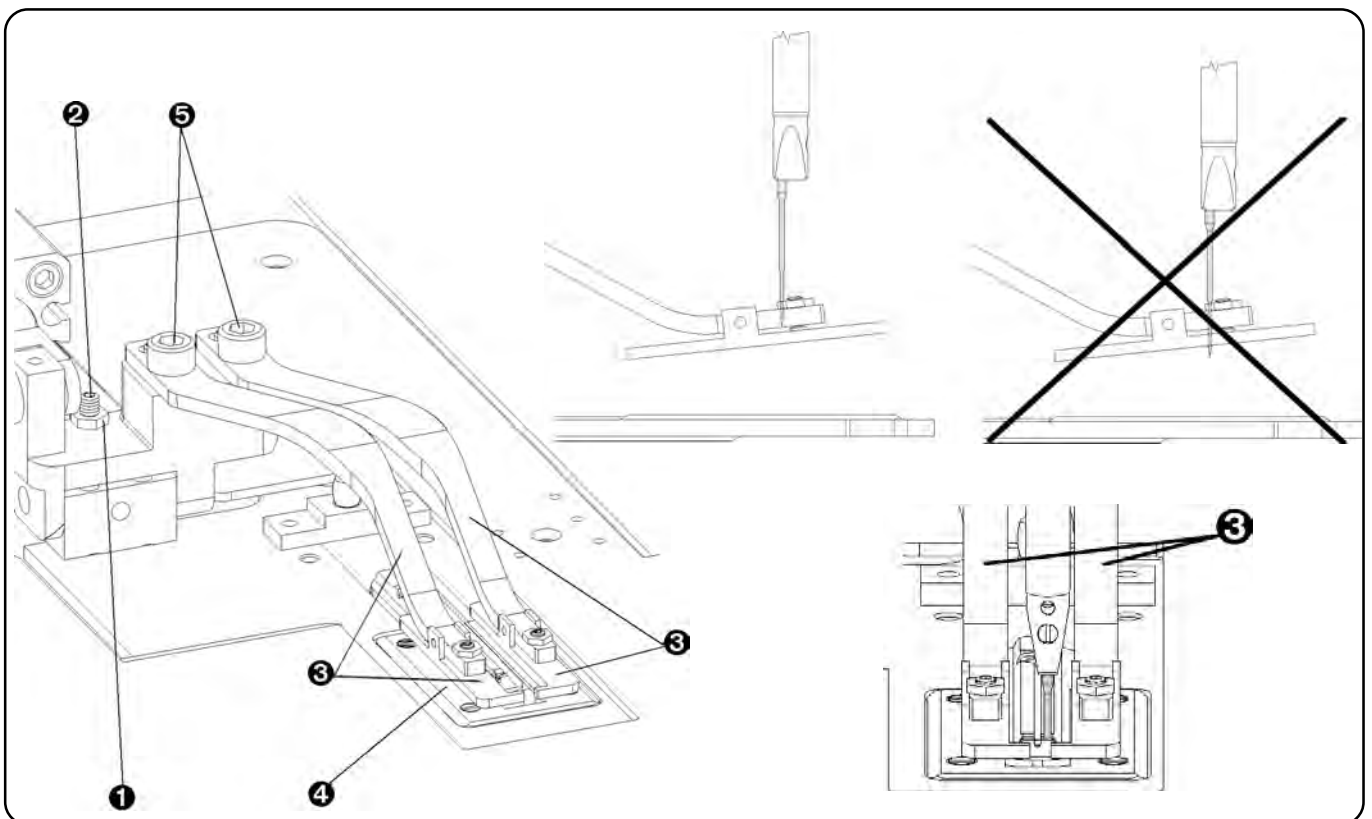

E - MACHINE ADJUSTMENTS

3. *Clamp feet pressure adjustment*

The whole length of the clamp feet must hold the sewn work with the same pressure.

- Push the clamp up/down button to close the clamp feet **3**.
- To adjust the clamp feet to the correct position, loosen the nut **6** and turn the screw **7**.
- tighten the nut **6**.

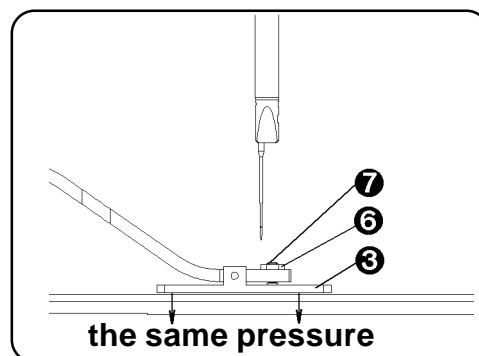

17. ADJUSTMENT OF THE STOPPING SENSOR POSITION

Follow the below described steps to set the position of the sensor.

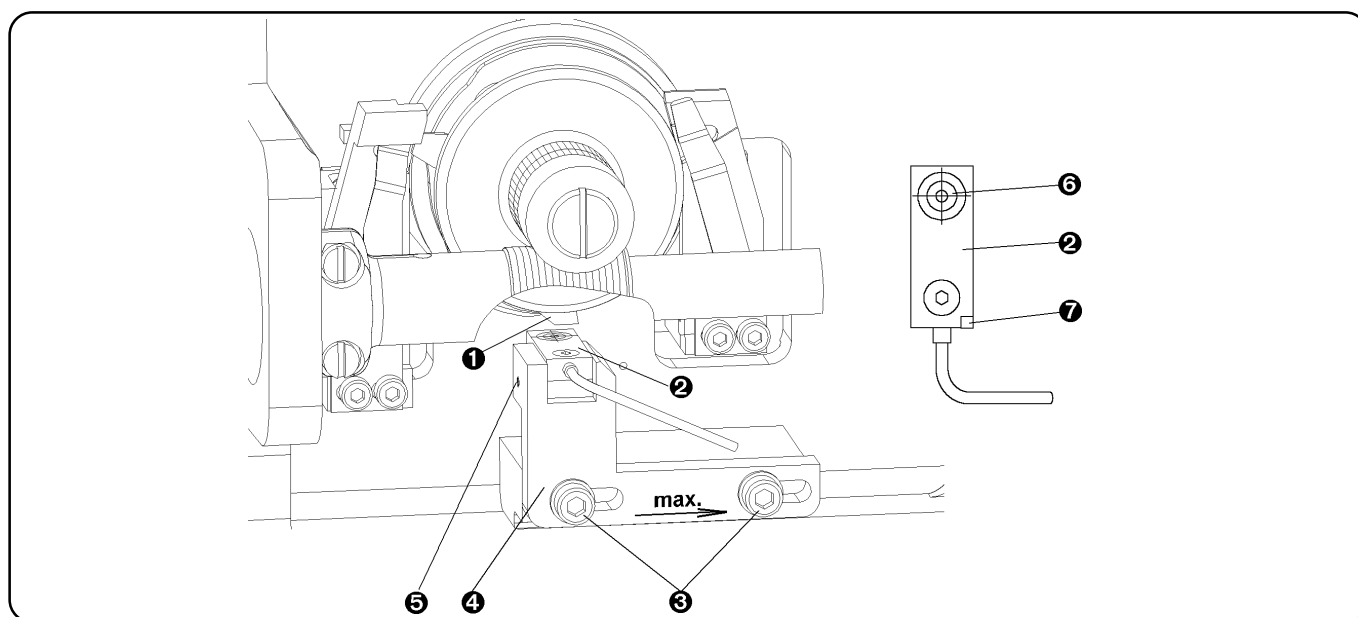

- Put machine in the service mode (see E-3).
- Turn the handwheel counter clockwise until the machine is in the position for sewing the second bar. The stop disk finger **1** must be perpendicular to the sensor **2**.
- Loosen the screws **3** and move the sensor bracket **4** to the right. Tighten the screws **3**.
- Loosen M3 screw **5** and adjust the sensor position so that the stop disk finger **1** is in the center of the sensor mark **6**. The red LED **7** lights up on the sensor.
- Tighten the M3 screw **5**.
- Return the machine head back to the working position.
- Push the F6 key on the control panel and switch the machine to the working mode.
- Connect the air tubes with the indexer clamp feet. Open the air supply.
- Start the machine and check the correct stopping of the machine. The needle bar must stop in the home (upper) position.





E - MACHINE ADJUSTMENTS

18. CHANGING THE DRIVE BELT

1. Remove the pulley cover **1** after loosening the M4 screws **2**.
2. By turning the handwheel **3** adjust the position of the shaft so that the screw **4** on the pulley **5** is level with screw **6** on the bearing carrier lower shaft.
3. Lock the position by the holder 24.0030.0.000 **7**, which is included in the accessories. Using the screw **6** fix the holder to the bearing holder upper screw.
4. Turn the pulley **8** of the needle bar shaft, until the needle bar reaches the upper position.
5. Lock the position by the holder 24.0024.0.000 **9**, which is included in the accessories. Using the screw **10** fix the holder to the bearing carrier lower mounting screw.
6. Rotate the motor pulley **11** until the marks **17** on the motor pulley and the motor bracket are aligned.
7. Loosen the screws **13** on the motor bracket **14** and move the motor with the machine bracket down to fit the belt.
8. Fit the belt **15** on the shaft pulleys **5**, **8** and motor pulley **11**. To tighten the belt **15**, move the motor bracket **14** with motor **16** up. Tighten the screws **13** to lock the motor bracket. Be sure the marks **17** are aligned.
9. Remove the pulley holders **7**, **9**.
10. Press the pedal to check the adjustment. The needle bar must be in the upper position.
11. Small changes of the needle bar adjustment are possible in the program parameters:
 - a) **needle bar did not reach the upper position**

- push  => „Ndl up pos 315“ appears on the display. After pressing the button  number is lightening. Requested value is



adjusted with  and .

Press  to confirm.

- to obtain the correct position of the needle bar, increase the value

- press , to return to the main screen

- b) **needle bar went beyond the upper position**

- push  =>  => „Ndl up posimp“

- to obtain the correct position of the needle bar, decrease the value

- push , to return to the main screen.

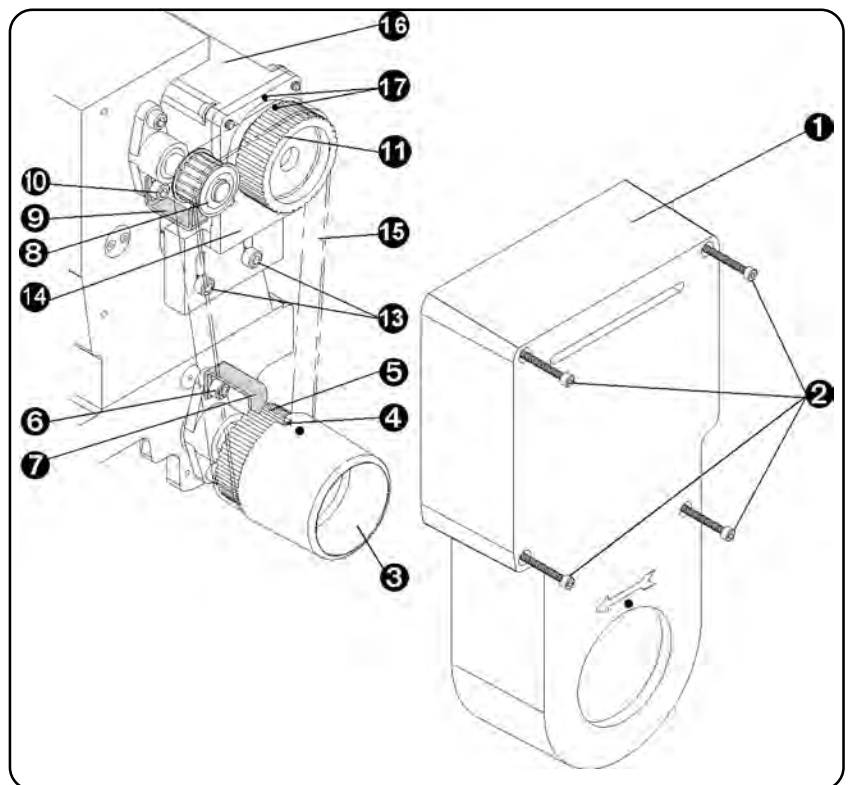

E - MACHINE ADJUSTMENTS

20. THE MAIN CAM CHANGE

1. Loosen the screws **1** and remove the holder **2**.
2. Unscrew the screws **3** and remove the right control spring **4** and the holder **5**.
3. Loosen the stud **6** and remove the worm gear hub **20** and the main cam assembly **7**. Dismantle the assembly.
4. Assemble the main cam assembly according to the following steps:
 - a) Install the washer **9** on the barring cam **3**. The mounting hole **22** must be covered.
 - b) Install the feed reversing cam **10** by the same way.
 - c) Place the stop disc **13** on the feed reversing cam **10** and fix it using the screws **11** and **12**.
 - d) Insert the springs **14** into the holes in the stop disc and install the drive disc spring **15**. Lock it using two screws **16**.
5. Remove the spring **17** from the pin **18**.
6. Using a grease, place the thrust washer **19** on a bedplate.
7. Install the main cam assembly **7** and the worm gear hub on the thrust washer. Lock it by stud **6**.
8. Install the spring **17** on the pin **18**.
9. Install the holder **5**, control spring **4** and tighten the screws **3**.
10. Install the holder **2** and lock it by screws **1**.
11. Turn the hand wheel to check the clearance on the main cam - see section E9, point 3.
12. Switch the machine on and check if the machine stops in the home position - see section E2, E9, point 1
13. Check the shape of a bar - see E9, point 2.
14. Sew a few buttonholes . The shape of a bar must be as shown on picture below.

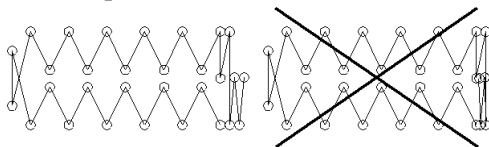

15. If incorrect, tilt the machine head and move the left shifter arm to the left to obtain correct shape of a bar (the clearance between the control spring and the shifter arm spring **21** must approximately be 1,2 - 1,5 mm)

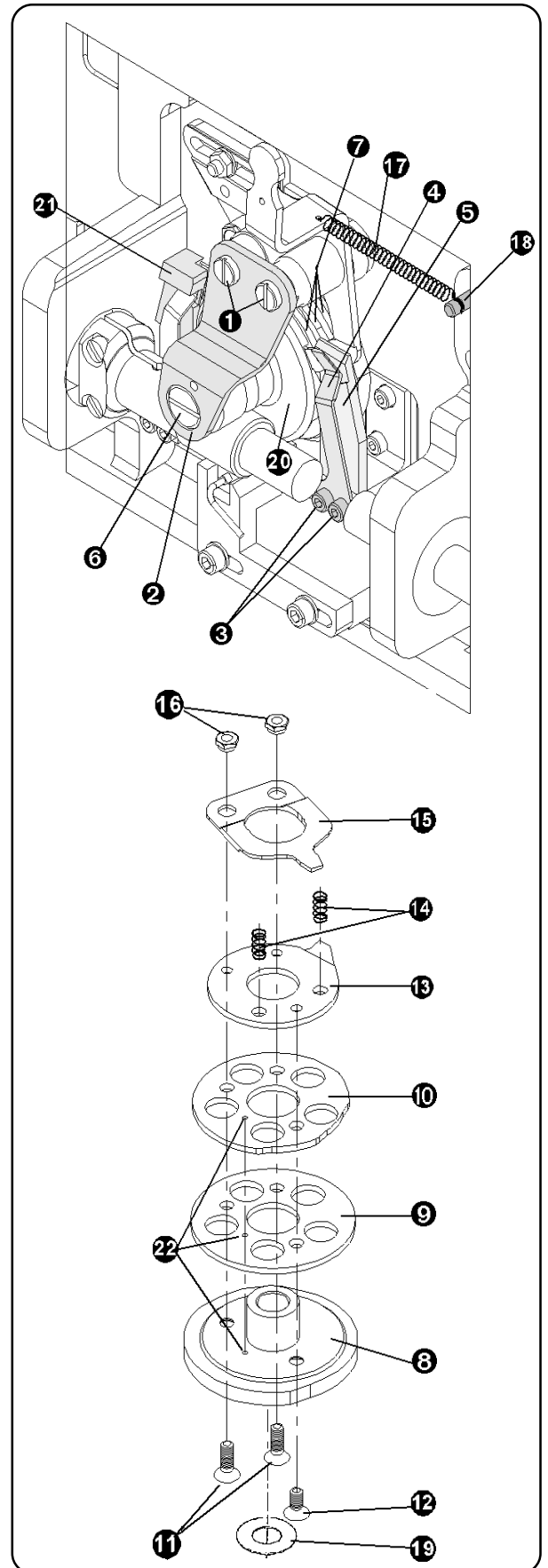

Revised 01/2009

e-mail: service@amfreece.cz; parts@amfreece.cz; website: www.amfreece.com
 Phone: +420 582 309 146 (Service), +420 582 309 286 (Spare Parts); Fax: +420 582 360 606

F - MACHINE MAINTENANCE

- Warning:**
- Check for damage to electrical cables
 - Check safety covers for damage and replace if needed immediately
 - Keep your hands out of the sewing area
 - Do not modify the machine in any way, which could eliminate safety parts
 - Do not attach external lights or other devices to the machine's electrical system
- Caution:**
- Do not neglect periodic maintenance.
 - If you have fault in electrical power supply, switch off the operating switch (circuit breaker).
 - Do not damage, correct and remove safety labels.
 - Do not work with the machine when you are under the influence of the drugs or alcohol.
 - User has to ensure the lighting of the working area minimal 750 Luxes.

1. MACHINE CLEANING AND MAINTENANCE

1. Switch the power off and disconnect air supply.
2. For cleaning and oiling, remove the cover **1** and take out the clamp feet mechanism **2**.
Clean the clamping area from the fabric and thread lints.
3. Open the needle bar cover **3** and clean the thread lints from the guides **4** and thread tension **5**.
4. Clean the thread lints and fabric from the sewing area - throat plate, loopers.
5. Lubricate the machine according to the section G 4.

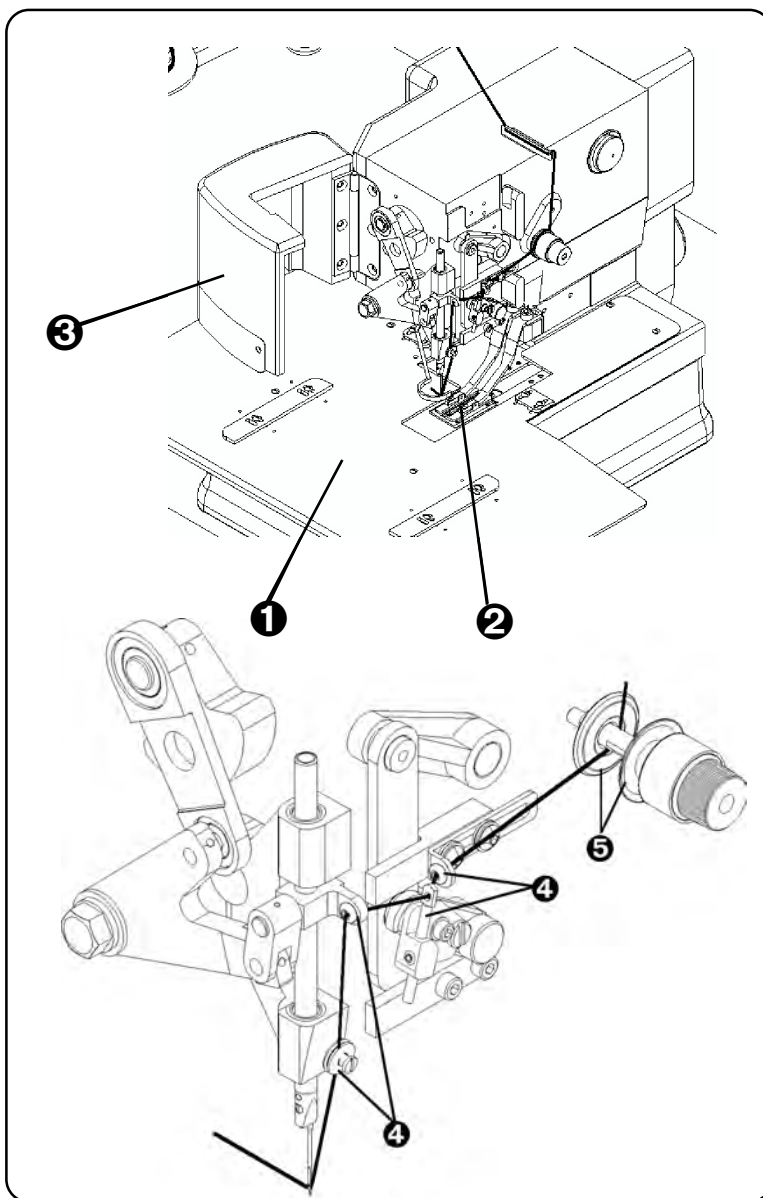

F - MACHINE MAINTENANCE

6. Remove the filter cover **6** with cleaning pad **7**.
 Remove the dust from the cleaning pad or in case of considerable dirt, wash it using a mild detergent.
 Perform the same cleaning on the rear fan .

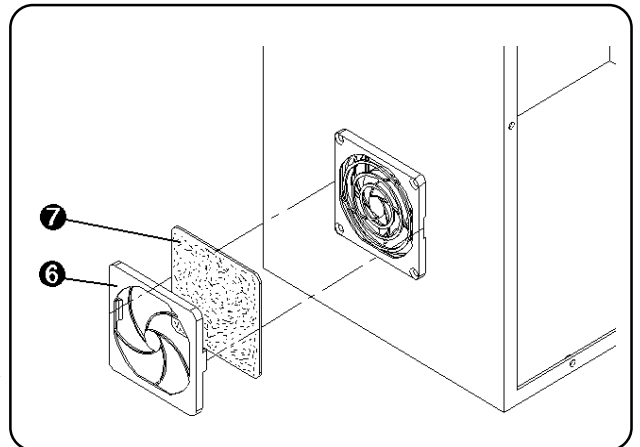

7. The filter and regulator maintenance
Bowl assembly - polycarbonate bowls may be damaged and possibly fail if exposed to synthetic oils, thinner solvents, trichlorethylene, kerosene and other aromatic hydrocarbons. Clean only with a neutral detergent .

Auto drain - Drain line length should be shorter than 5 m. Be sure not to have any upward turns in the drain line which would prevent drainage.

If the unit has no function it is necessary to:

- check if the supplied pressure is higher than the set pressure of the regulator
- check if the valve assembly is clean
- check the membrane or spring because of damage
- check if the air flow direction is correct

Change of the filter element

Conditions

- low flow rate
- high pressure drop
- when the pressure drops to 0.7 bar
- filter element change after one year (in case it has not been changed)

- unscrew the polycarbonate bowl **8**
- take the filter element out **9** with baffle **10**
- change old filter element with new one
- fit the baffle **10** into new filter element **9** and place them both back
- place the polycarbonate bowl back

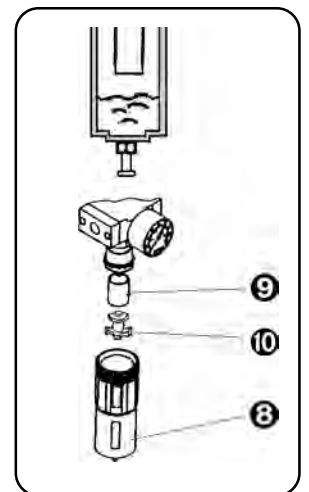

8. Check the mechanisms especially in the sewing area by sight.
9. When the maintenance and checking are finished, insert the clamp feet mechanism to the machine.

F - MACHINE MAINTENANCE

2. PERIODIC MAINTENANCE

once a day (8 hours of operation)



- cleaning of the sewing mechanism area and inner frame of the machine

once a week (40 hours of operation)

- lubrication of mechanisms - see area F4.

once a month (160 hours of operation)

- visual check - external and internal mechanisms
- fill oil into reservoir with oil level indicator, or sooner if required
- check of the clearance in sewing mechanism drive
- check of the screw connections tightening (obtain values below)
- check of condensate in regulator
- check of dirty of cleaning pads in control box

Recommended values for screws tightening (Nm):			
			
M3	0,5	0,6	0,8
M4	1,2	1,5	2,0
M5	2,5	3,0	4,0
M6	4,0	5,0	7,0
M8		8,0	16,0
M10		10,0	30,0

F - MACHINE MAINTENANCE

3. LUBRICATION DIAGRAM

The machine is mostly equipped with needle and ball bearings, which in combination with single lubrication circuit decrease the requirements for maintenance.

Circuit I - with the oil supply in oil indicator for lubrication of the bite, feeding and looper levers and worm gears. In case of replacement of any part of distribution, it is possible to order the tube kits and wicks. To connect the tubes - see picture.

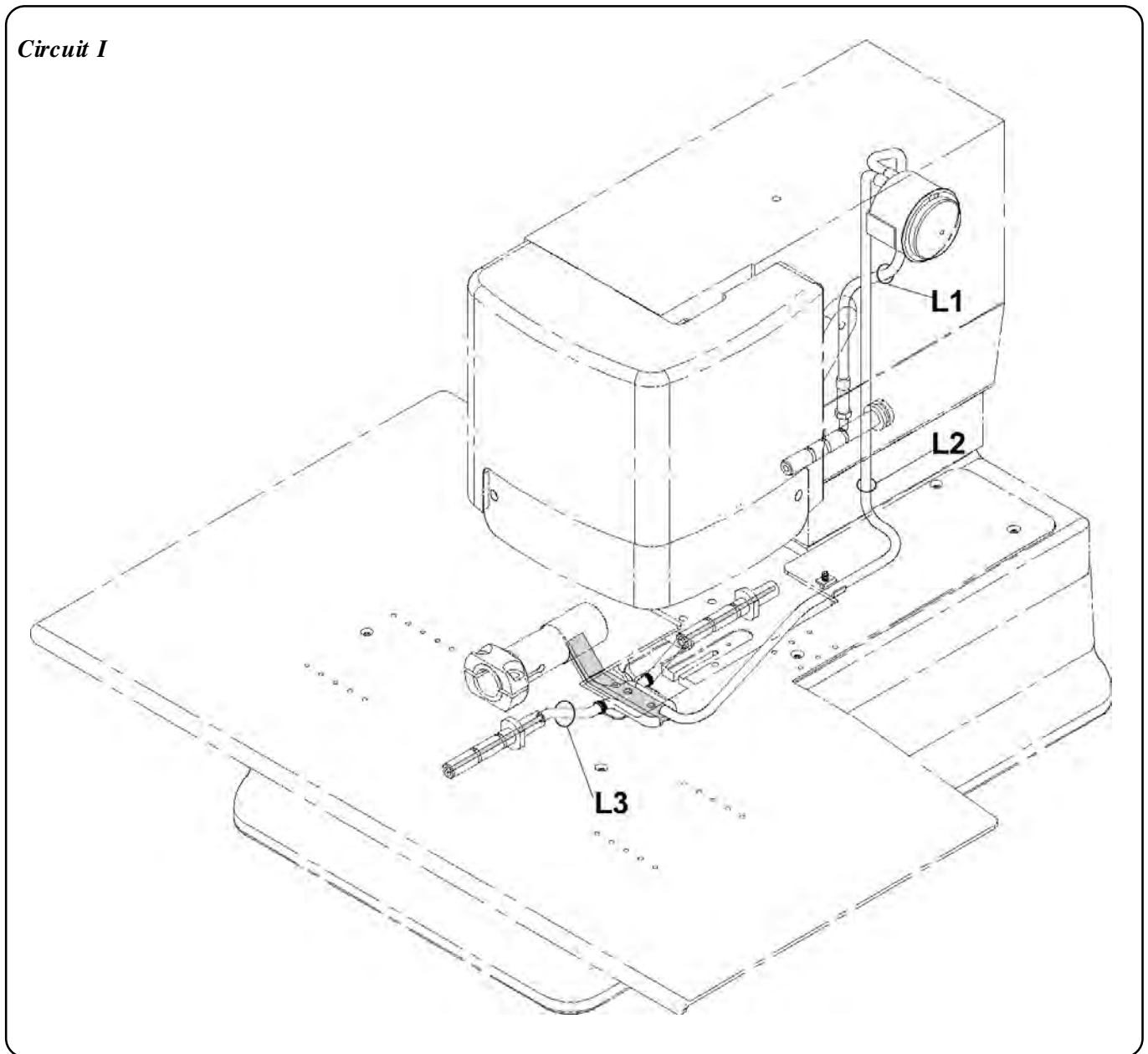

F - MACHINE MAINTENANCE

4. MACHINE LUBRICATION

1. It is necessary to lubricate the places shown below before the machine is switched on for the first time or after a long idle period. Use oil ESSO TERESSO 32 or similar quality.
2. The amount of oil in the reservoir **①** is indicated by the red mark. Too much oil may cause its overflowing from the base area.
3. The reservoir is fitted through the hole **②** in front of the gage.
4. The points for lubrication of the needle bar mechanism **③** and draw-off mechanism **④** are shown in the illustration below (after opening the needle bar cover **⑤**). Lubricate the main cam worm gear through the hole **⑥**. Lubricate all of these points every 8 hours.

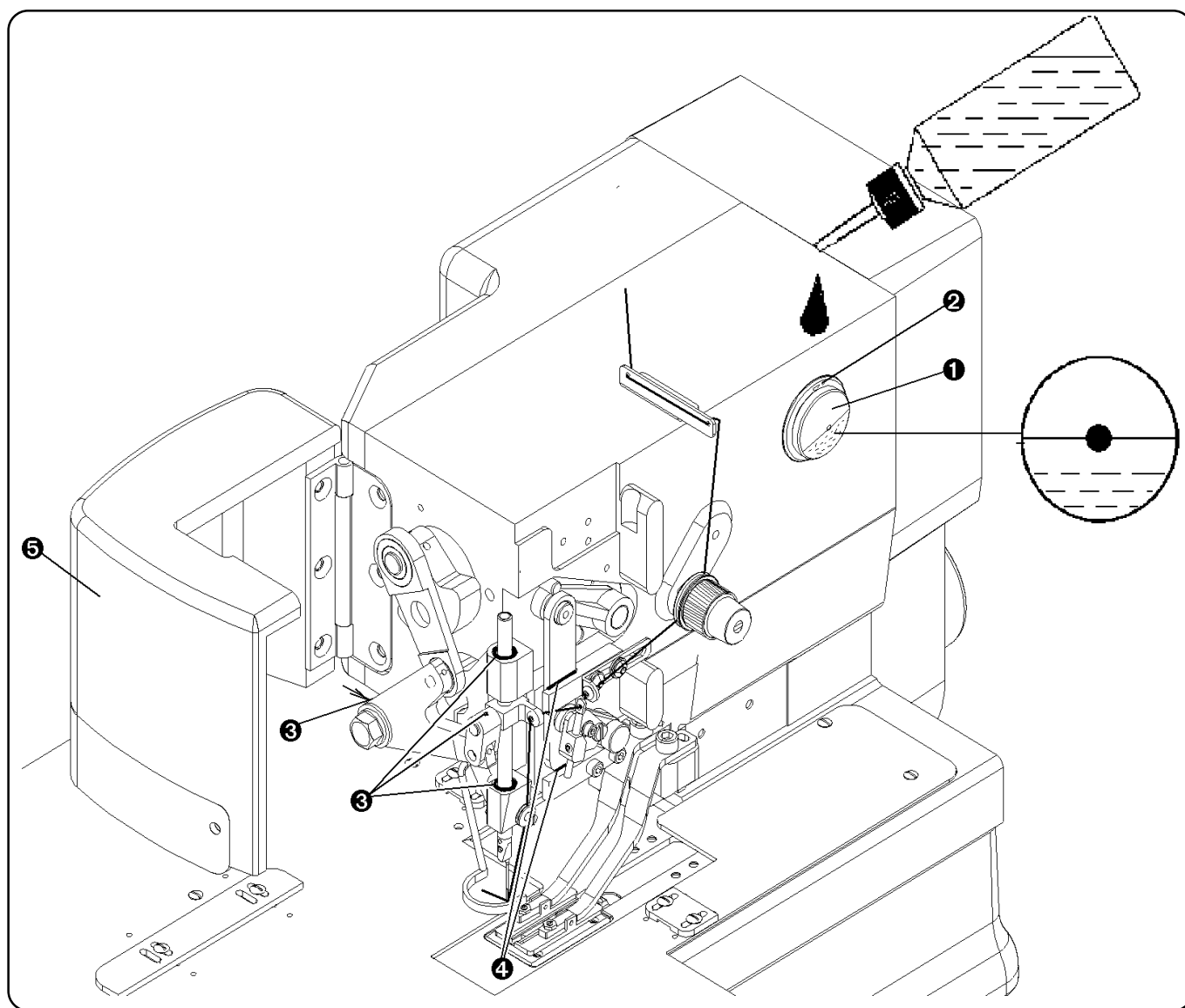

F - MACHINE MAINTENANCE

5. Tilt the machine head on the rest pin and lubricate the places shown in the picture.

- | | | | |
|---|---------------|---|---------------------|
| ⑦ | looper shafts | ⑪ | looper cam surfaces |
| ⑧ | roller | ⑫ | feed cam surfaces |
| ⑨ | shifter | ⑬ | bite cam surfaces |
| ⑩ | bevel gears | ⑭ | trimmer shaft |

Tilt the sewing head back into the sewing position.

6. After lubrication it is important to sew minimum 10 buttonholes on scrap fabric to dispel any excess oil. Wipe all visible excess oil from the mechanism in the work area.

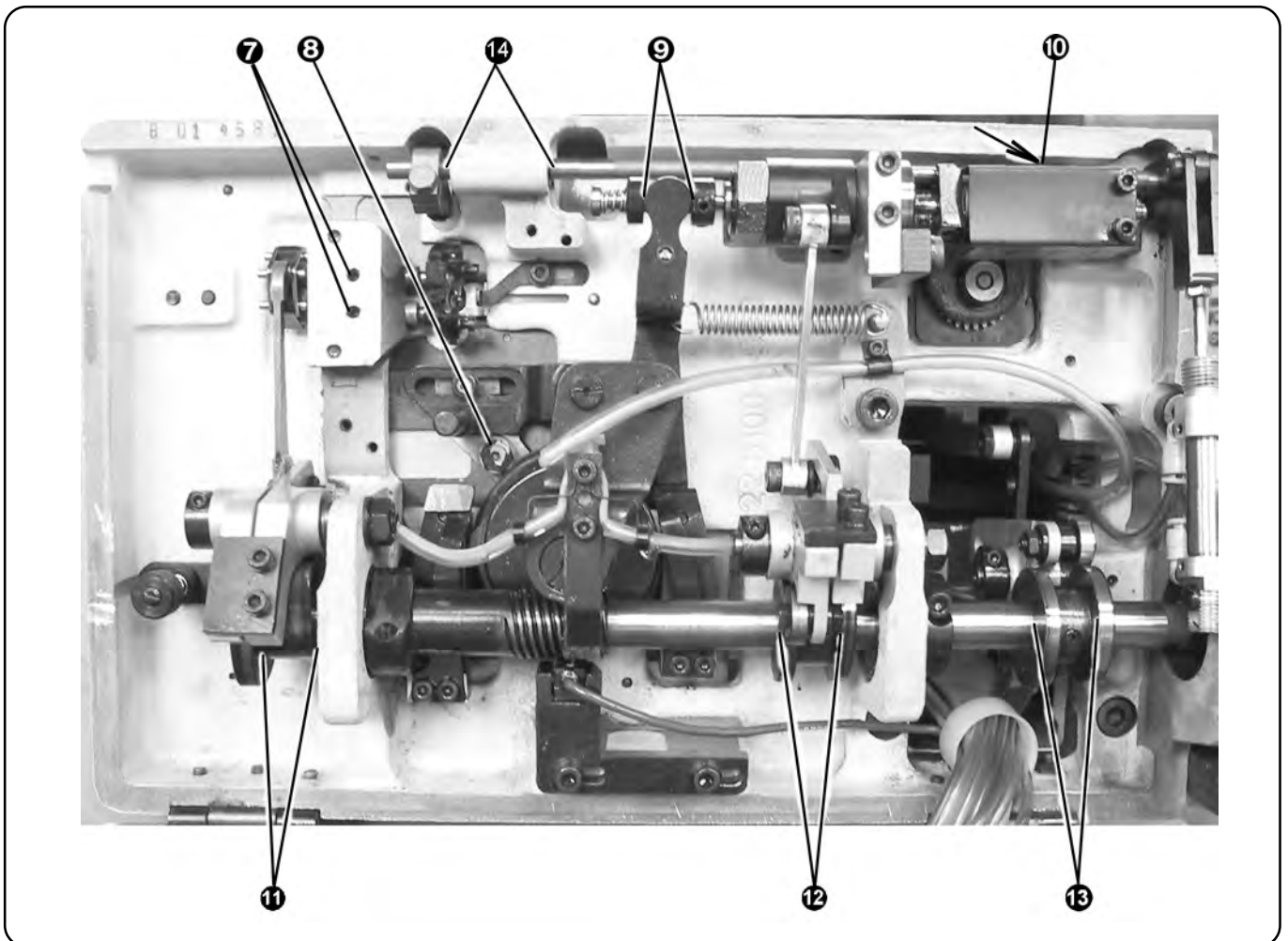

F - MACHINE MAINTENANCE

5. MACHINE DISPOSAL

1. To ensure machine ecological disposal, it is necessary to remove nonmetallic parts from the machine. To take these parts out, it is necessary to perform the partial dismantling of the machine, remove covers, dismantle the machine arm and remove the frame.
2. Aluminium and duralumin parts must be treated separately, also nonferrous metal parts and plastic parts.
3. Parts mentioned in point 2 can be found in the spare parts manual with these marks:

- aluminium parts
- non-ferrous metal parts
- plastic and non-metalic parts

G - PNEUMATIC DIAGRAM

S4000 ISBH - P n e u m a t i c d i a g r a m

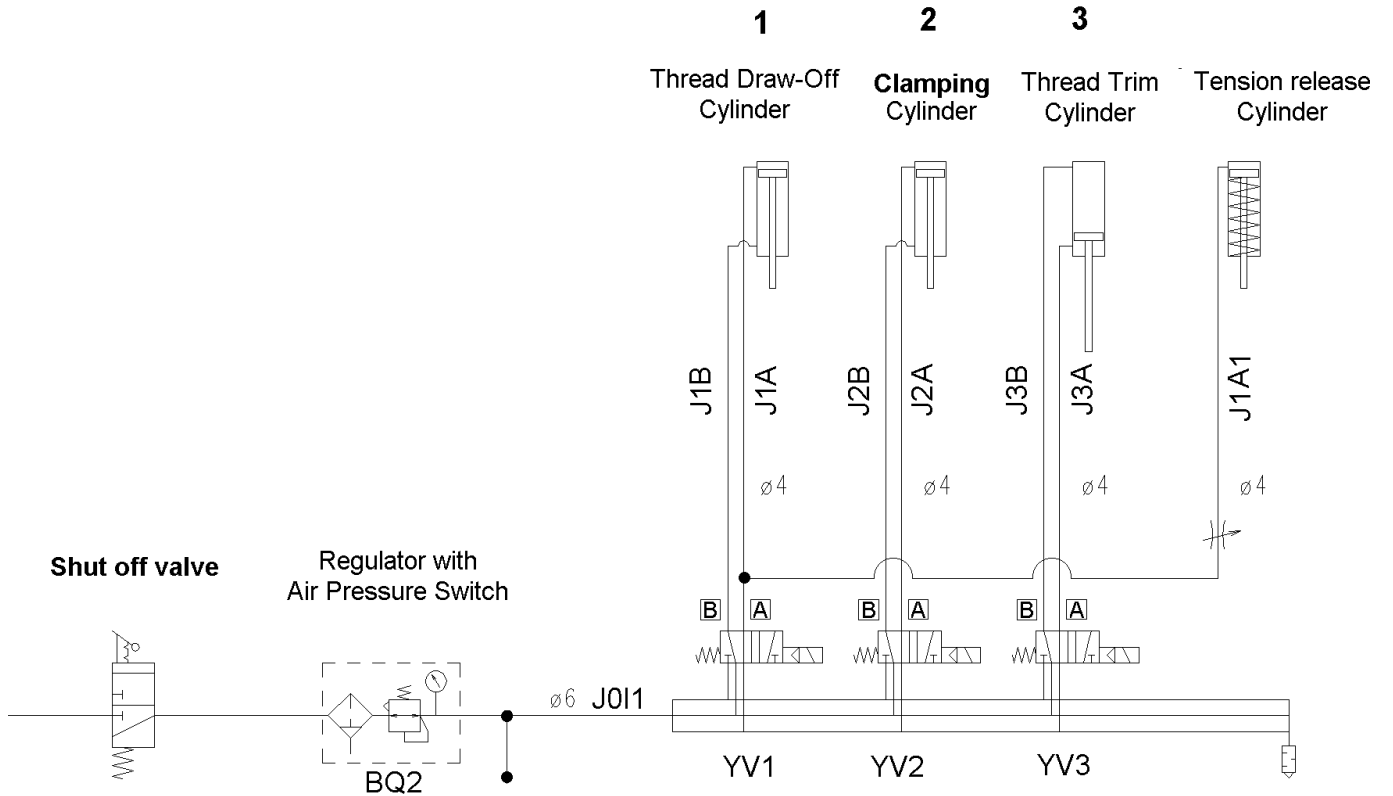

H - ELECTRICAL DIAGRAM

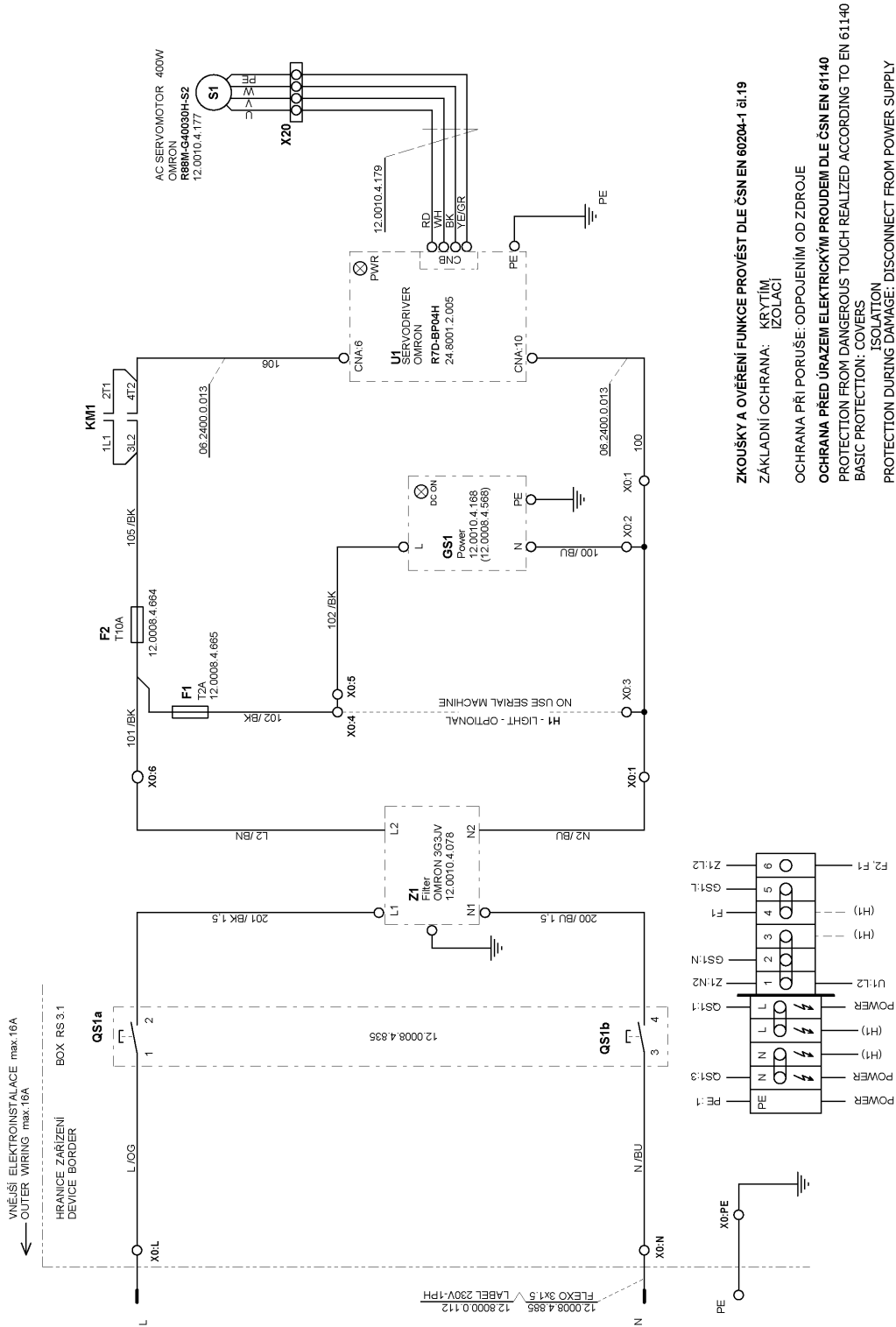

ZKOUŠKY A OVĚŘENÍ FUNKCE PROVĚST DLE ČSN EN 60204-1 čl.19

ZÁKLADNÍ OCHRANA: KRYTÍM, IZOLACÍ

OCHRANA PŘI PORUŠĚ: ODPOJENÍM OD ZDROJE

OCHRANA PŘED ÚRAZEM ELEKTRICKÝM PROUDEM DLE ČSN EN 61140

PROTECTION FROM DANGEROUS TOUCH REALIZED ACCORDING TO EN 61140

BASIC PROTECTION: COVERS

ISOLATION PROTECTION DURING DAMAGE: DISCONNECT FROM POWER SUPPLY

H - ELECTRICAL DIAGRAM

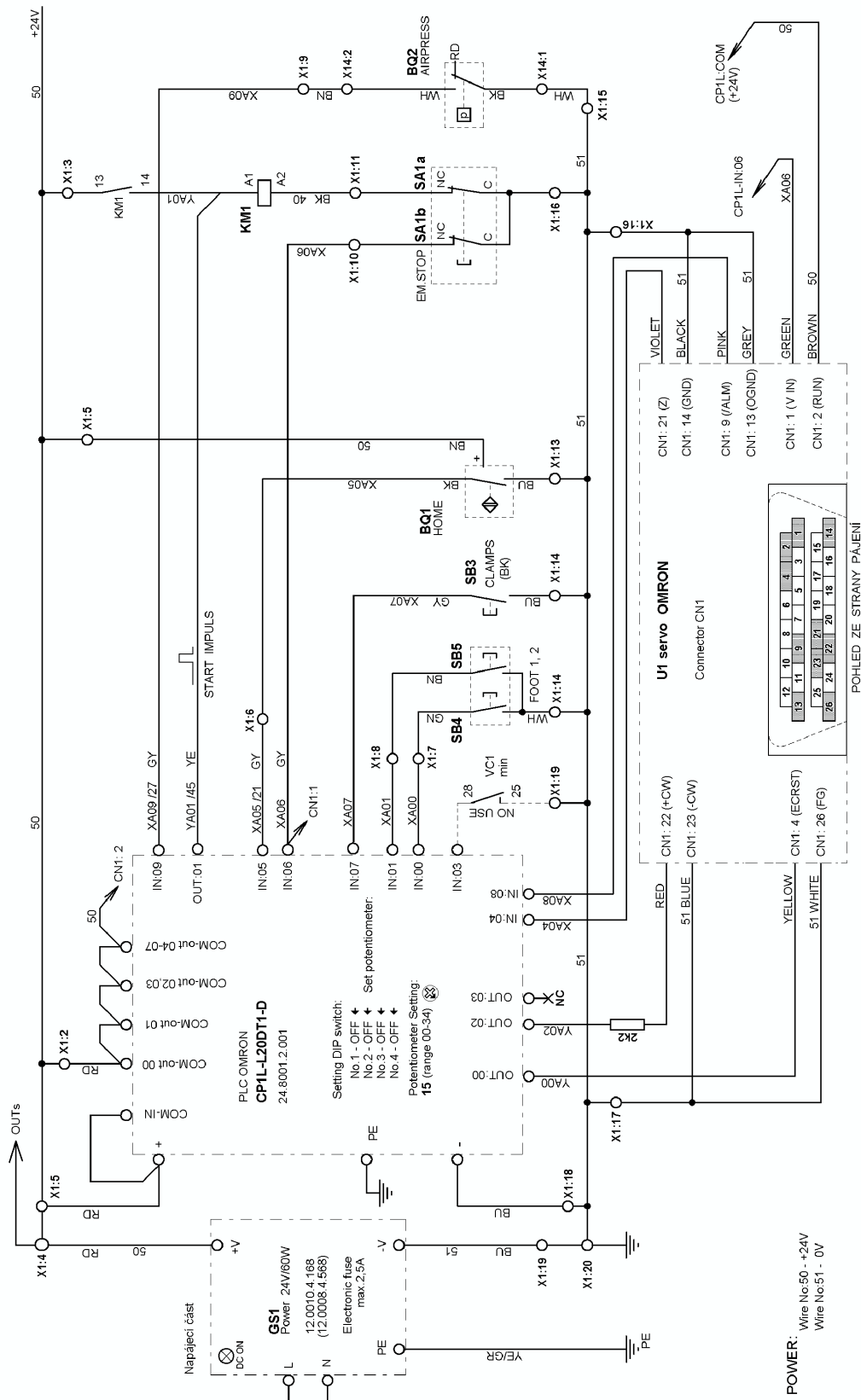

POWER:
Wire No:50 - +24V
Wire No:51 - 0V

Revised 11/2009

e-mail: service@amfreece.cz; parts@amfreece.cz; website: www.amfreece.com

Phone: +420 582 309 146 (Service), +420 582 309 286 (Spare Parts); Fax: +420 582 360 606

H - ELECTRICAL DIAGRAM

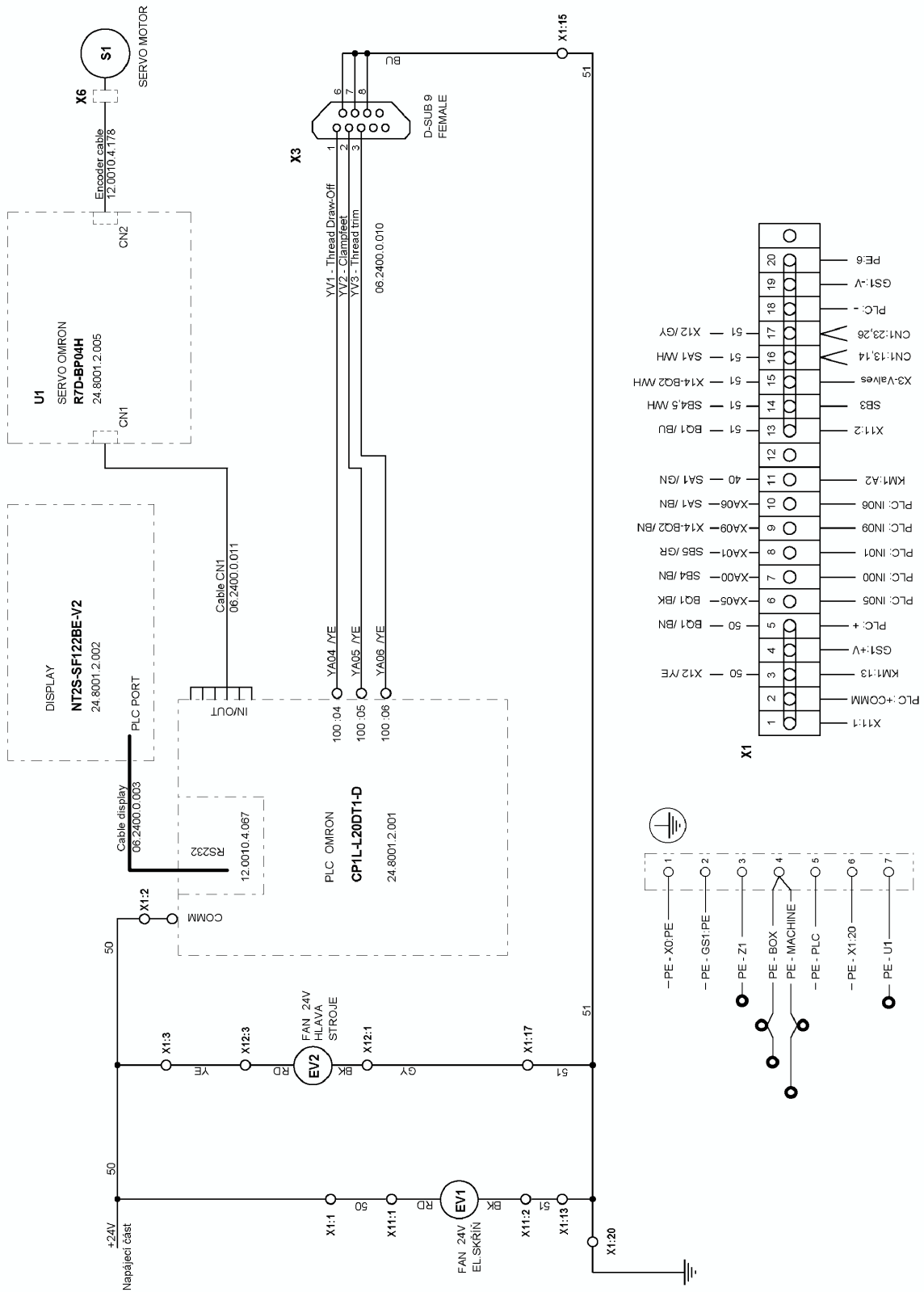

H - ELECTRICAL DIAGRAM

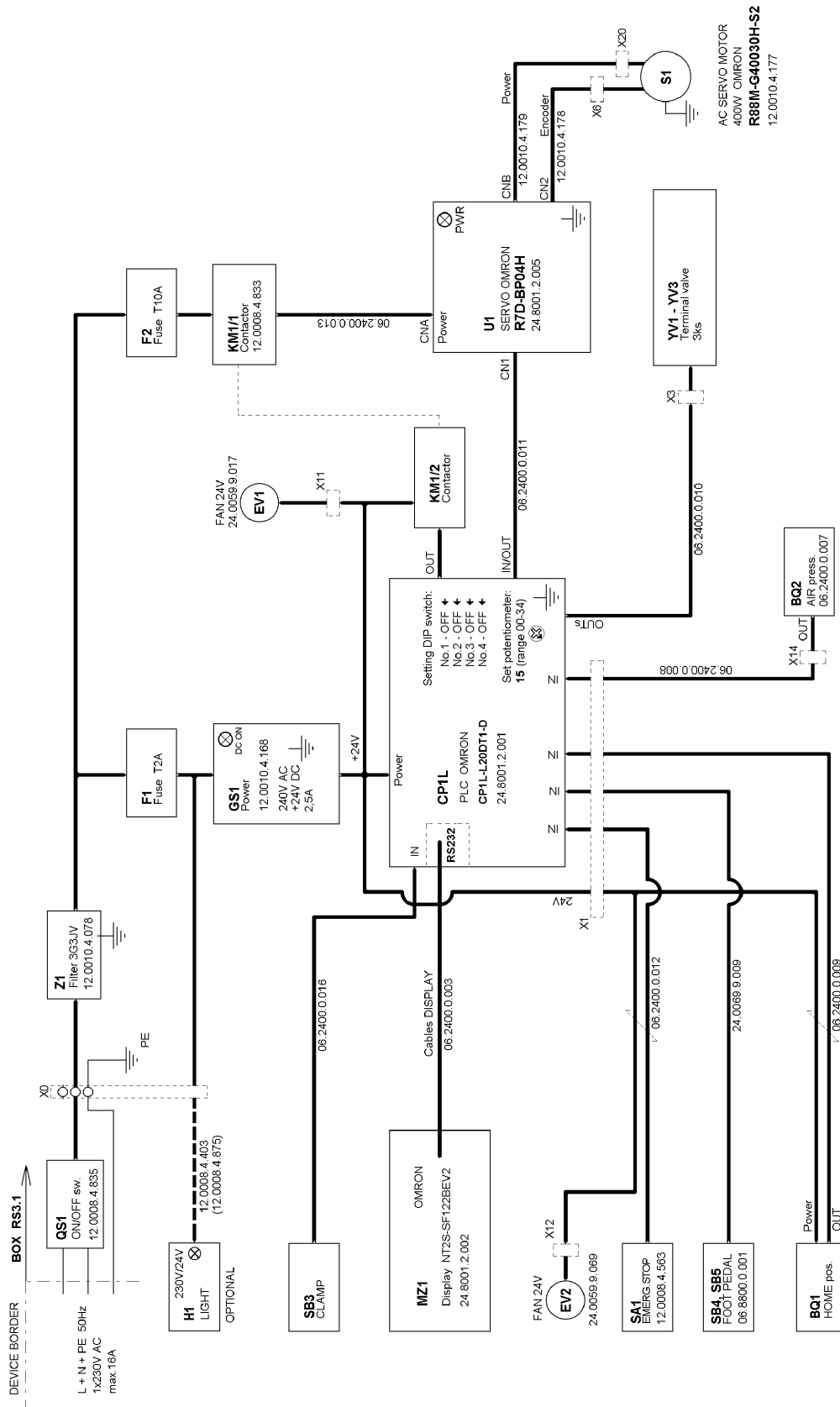

Revised 11/2009

e-mail: service@amfreece.cz; parts@amfreece.cz; website: www.amfreece.com

Phone: +420 582 309 146 (Service), +420 582 309 286 (Spare Parts); Fax: +420 582 360 606

H - ELECTRICAL DIAGRAM

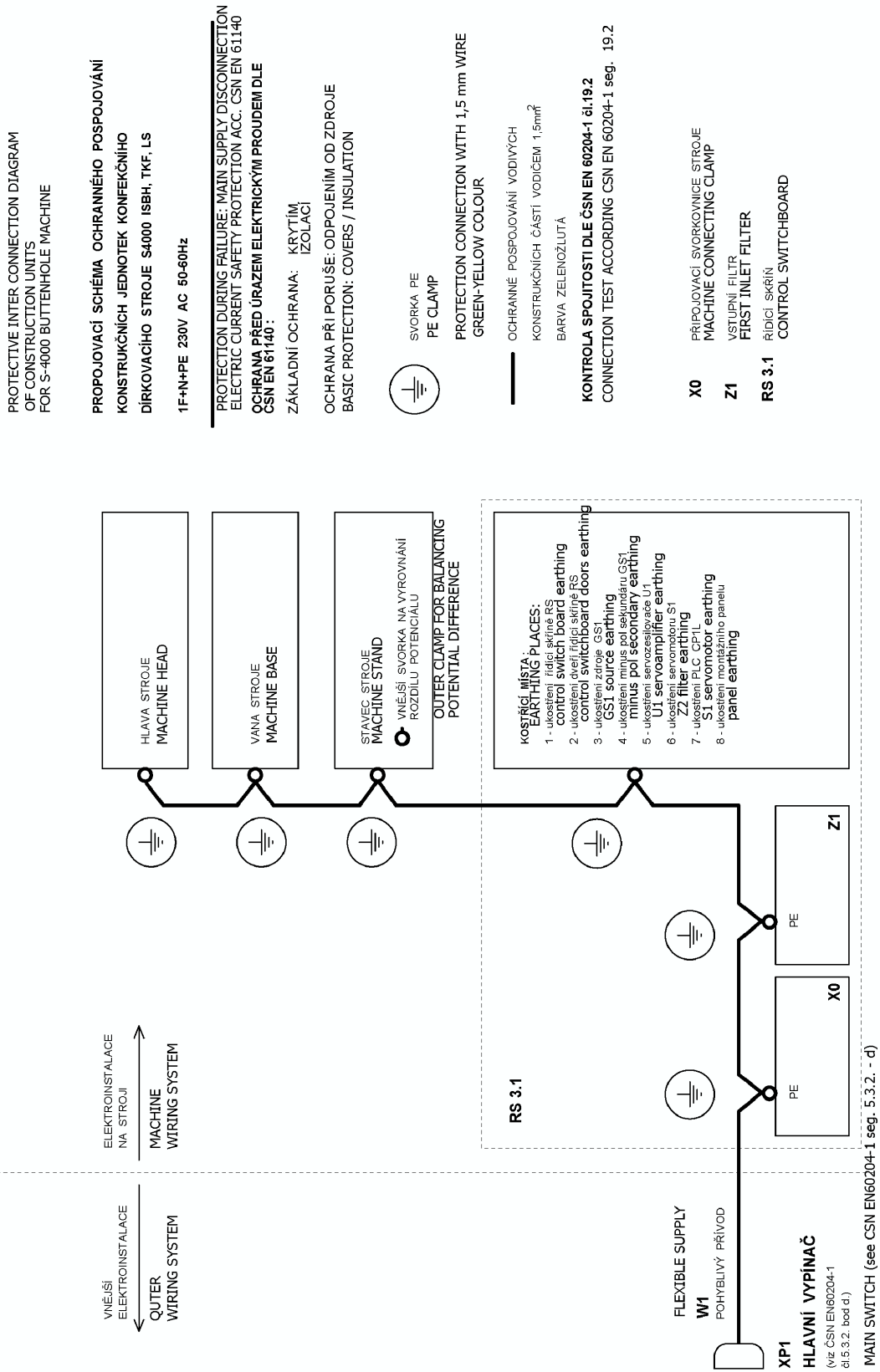

TROUBLESHOOTING - TABLE OF CONTENTS

1. MECHANICAL FAULTS	2-2
2. CONTROL PANEL DISPLAY ERROR MESSAGES	2-5
3. SERVO ERROR MESSAGES	2-6
4. ELECTRICAL FAULTS	2-7

Revised 01/2009

e-mail: service@amfreece.cz; parts@amfreece.cz; website: www.amfreece.com

Phones: +420 582 309 160 (Service), +420 582 309 189 (343) (Spare Parts); Fax: +420 582 360 606

TROUBLESHOOTING

1. MECHANICAL FAULTS

SYMPTOM	POSSIBLE CAUSE	PROBABLE SOLUTION
Thread breakage	Needle, looper, throat plate damaged	Change damaged parts
	Incorrect needle and sewing mechanism adjustment	Check the adjustment of the mechanisms
	Thread tension is too tight	Adjust correct tension
	Incorrect threading	See section C3 for checking.
	Thread guides polished incorrectly	Polish
	Poor thread quality	Replace thread
	Thread is too heavy for selected needle and throat plate	Use recommended thread sizes - see section A4
Machine fails to sew	Needle, looper, throat plate damaged	Change damaged parts
	Incorrectly adjusted needle bar height	See section E4 for checking
	Incorrectly adjusted clearance between needle and throat plate	See section E5 for checking
	Incorrect loopers timing	See section E12 for checking
Machine sews in one spot	Incorrectly adjusted front stop	Adjust the stop - see section E11

TROUBLESHOOTING

SYMPTOM	POSSIBLE CAUSE	PROBABLE SOLUTION
Stitch skip at the beginning of sewing	Needle, looper, throat plate damaged	Change damaged parts
	Needle thread end is too short	See section E13, point 2
	Incorrectly adjusted needle bar height	See section E4
	Incorrectly adjusted clearance between needle and throat plate	See section E5
	Incorrect loopers timing	See section E12
	Incorrectly adjusted clamp feet pressure	See section E 16, point 3
Stitch skip during sewing	Needle, looper, throat plate damaged	Change damaged parts
	Incorrectly adjusted needle bar height	See section E4
	Incorrectly adjusted clearance between needle and throat plate	See section E5
	Incorrect loopers timing	See section E12
	Incorrect thread tension adjustment	Adjust the tension correctly
	Incorrect threading	See section C3
	Thread loops are too small	See section E13 point 3
	Incorrectly adjusted clamp feet pressure	See section E16 point 1
	The clamp feet are adjusted too far from the sewing	See section E16 point 2

TROUBLESHOOTING

SYMPTOM	POSSIBLE CAUSE	PROBABLE SOLUTION
Thread not trimmed at the end of the cycle	Trimming knife damaged	Replace
	Low air pressure at trimming cylinder	Check supply pressure
	Flow control valve to tension cylinder closed	See section E14 point 3
	Incorrect loopers timing	See section E12
	Incorrect setting of trimming delay	Change Trim delay parameter
	Trimming length incorrectly set	Change Trim time parameter
Sewing motor turns, machine does not sew	Belt broken or loose	See section E18 for changing
Machine sews continually, does not stop	Stopping sensor adjusted incorrectly	See section E17 for correct position adjustment
Zero pressure on regulator	Shut off valve closed	Open the shut off valve
Low air pressure	Filter element dirty	Change the filter element
	Air fitting or tubing obstruction	Check supply guides

TROUBLESHOOTING

2. ERROR MESSAGES OF THE CONTROL PANEL DISPLAY

SYMPTOM	POSSIBLE CAUSE	PROBABLE SOLUTION
Low air pressure	Hand valve of the regulator switched off - if assembled	Open the hand valve
	The air pressure in the air supply piping below 5 MPa	Increase the air pressure
Emergency stop	Emergency Stop button is switched on	Release the Emergency Stop button
Operation mode	The machine is in the operation mode, motor is disconnected	Press F6 key on the control panel
Low voltage	The power supply is below 185V - relay HRN-35 is installed	Call electroengineer in a plant
Motor not ready	The power supply is below 185V - relay HRN-35 is not installed	Call electroengineer in a plant

TROUBLESHOOTING

3. ERROR MESSAGES OF THE SERVO

The following messages can be seen on the servo display, which is placed inside the control box. In order to eliminate these messages, switch off the machine for 1 minutes. Then switch the machine on again. The error message should not appear on the display. If the message appears - call AMF Reece service.

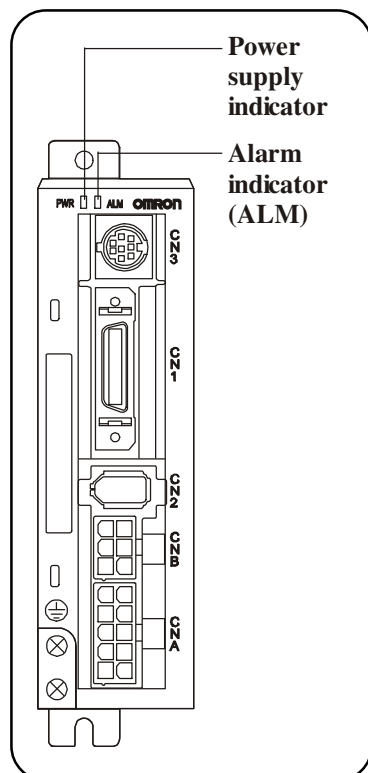

PWR - Power supply indication:



INDICATOR	STATUS
Lit green	Voltage is good
Lit orange - Flashes at a 1 sec. intervals	Warning - i.e.: - Exceeded power - Exceeded feed back - Default of inner fan
Lit red	Alarm - default

ALM - Default indication (Alarm indicator):

in case default appears, the indicator is switched on.

TROUBLESHOOTING

4. ELECTRICAL FAULTS

SYMPTOM	POSSIBLE CAUSE	PROBABLE SOLUTION
 <p>When switch in position I, neither the work light, display or the cooling fan operate</p>	No power supply	Check main power supply or voltage in the socket
	Fuse F1 failure	Replace fuse PN 12.0008.4.665
	Power switch QS1 damaged	Replace the switch 12.0008.4.835
	Power GS1 failure	Replace the power 12.0010.4.168
	The supply voltage is above 255 V - relay VC1 installed	Call electroengineer in the plant
	Relay VC1 failure	Replace the relay 12.0008.4.690
	Damaged Z1 filter	Replace the filter 12.0010.4.078
 <p>When switch in position I, display does not operate</p>	Cable from the display disconnecte	Check the display connection
	Display or its control damaged	Replace display PN 24.8001.2.002
<p>When sewing operation started, motor does not operate. Contactor KM1 switched on.</p>	Fuse F2 damaged	Replace fuse 12.0008.4.664
	Contactor KM1 damaged	Replace contactor 12.0008.4.833
	Servo U1 error or filter Z2 error	Call AMF Reece service or replace servo U1 24.8001.2.005
	Error in sewing motor circuit	Switch the machine off for 1 minute, or restart it, alternatively call AMF Reece service
<p>When the machine is switched on, incorrect type of the machine appear on the display (example: S4000 ISBH instead of S4000 BH)</p>	The PLC incorrectly set	Set the potentiometer on the PLC according to the electrical diagram - see service section, section H)

TROUBLESHOOTING

SYMPTOM	POSSIBLE CAUSE	PROBABLE SOLUTION
When sewing operation started, motor fails to operate. Contactor KM1 switched off.	Make sure the machine is ready for operation	Press key F6 - see D1, point 6
	Contactor KM1 damaged	Replace contactor 12.0008.4.833
	Check the Emergency Stop button	Replace button 12.0008.4.563
	Control unit PLC error	Replace the control unit PLC 24.8001.2.001
The needle does not stop in the upper position	Position of the sensor BQ1 incorrectly adjusted	Adjust according to section E17
	Sensor BQ1 failure	Replace the sensor 06.2400.0.009
	Check the servo amplifier and servo	To set the servo amplifier - call AMF Reece service, alternatively replace motor 12.0010.4.177 and servo amplifier 24.8001.2.005
When sewing operation started, air valves do no operate. The air pressure correct.	Fork is not fitted properly into connector X3	Check the connector X3 connection
	Control unit PLC error	Replace the control unit 24.8001.2.001

TROUBLESHOOTING

Notes:

TROUBLESHOOTING
