

EFKA dc 1500

CONTROL

AB286A5400

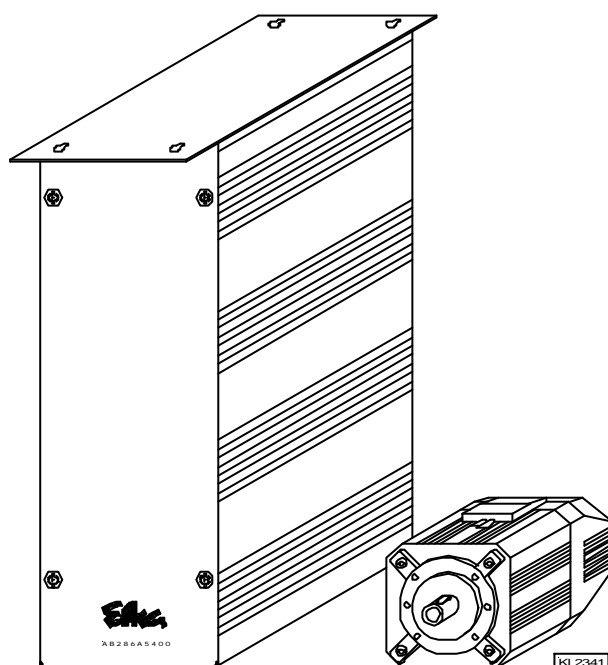

INSTRUCTION MANUAL

No. 402280

English

EFKA
FRANKL & KIRCHNER
GMBH & CO KG

EFKA
EFKA OF AMERICA INC.

EFKA
EFKA ELECTRONIC MOTORS
SINGAPORE PTE. LTD.

CONTENTS	Page
1 IMPORTANT SAFETY INSTRUCTIONS	5
2 RANGE OF APPLICATIONS	6
2.1 USE IN ACCORDANCE WITH REGULATIONS	6
3 COMPLETE DRIVE UNIT CONSISTING OF	6
3.1 SPECIAL ACCESSORIES	6
4 STARTING SERVICE	7
5 SOCKET CONNECTORS	7
6 CONNECTION DIAGRAM	8
7 INTERFACE DEFINITION	11
7.1 BAUD RATE SELECTION	11
7.2 PROTOCOL	11
7.3 TRANSMIT TIMEOUT BEFORE "NAK"	11
7.4 BYTE TO BYTE TIMEOUT	11
7.5 COMMUNICATION MONITORING (SYSTEM VALUES D, GROUP E)	12
7.6 CONTROL CHARACTERS	12
7.7 SPECIAL CHARACTERS	12
7.8 DATA LINK ESTABLISHMENT	12
7.9 RTS	12
7.10 TEXT	12
7.11 STOP INPUT	13
7.12 ERROR OUTPUT	13
8 PARAMETERS	13
8.1 SPECIAL FEATURES	17
8.2 BIT DESCRIPTIONS	17
8.2.1 "RDY" BIT 5 IN STATUS BYTE 1	17
8.2.2 "NPE" BIT 6 IN STATUS BYTE 1	18
8.2.3 "P1E, P1A, P2E, P2A, P3E, P3A" IN STATUS BYTE 2	18
8.2.4 "PSYN" BIT 7 IN STATUS BYTE 1	18
8.2.5 "P2T" BIT 0 IN CONTROL BYTE 2	18
8.2.6 "2N" BIT 1 IN CONTROL BYTE 2	18
8.2.7 "ZSTP_" BIT 2 IN CONTROL BYTE 2	18
8.2.8 "PNLIM" BIT 5 IN CONTROL BYTE 2	18
8.3 FUNCTIONAL DESCRIPTIONS	18
8.3.1 STOP SEGMENT ANGLE FOR POSITIONING (SYSTEM -VALUES C, GROUP 7)	18
8.3.2 RUN-OUT ANGLE FOR POSITIONING (SYSTEM VALUES D, GROUP E)	19
8.3.3 ACCURATE POSITIONING	19
8.4 TABLE OF PARAMETERS	20
9 ASCII DATA TRANSFER	21
10 LIST CALL	21
11 INTERRUPT CONTROL	23

CONTENTS	Page
12 EXAMPLES FOR SERIAL DATA TRANSFER	24
12.1 POWER ON	24
12.2 OPERATION	24
13 POSITION SETTINGS	27
14 AUDIBLE SIGNALS	28
14.1 AUDIBLE ERROR SIGNALS	28
14.2 AUDIBLE SIGNAL OF THE MODULE ADDRESS	28
15 EXAMPLES OF CONNECTIONS	29
15.1 RESET WITH EXTERNAL 24V SUPPLY	29
15.2 RESET WITH OPTOCOUPLER	29
15.3 BUS-CAPABLE SIGNALS IRQ1 AND IRQ2	30
15.4 SIGNALS U/D, SYN AND G1	30
15.5 BUS-CAPABLE SIGNALS POS1 AND FEHLER [ERROR]	30
15.6 DIFFERENTIAL SIGNAL LINK	31
15.7 RS485 DATA TRANSFER WITH ONE DRIVE	31
15.8 RS485 DATA TRANSFER WITH SEVERAL DRIVES	32
15.9 ACTIVATE / DEACTIVATE TERMINATING RESISTOR	32
15.10 SYNCHRONIZATION SIGNAL FOR POSITIONING	33

1 Important Safety Instructions

When using an EFKA drive and accompanying devices (e.g. for sewing machines), basic safety precautions should always be followed, including the following:

- Read all instructions thoroughly before using this drive.
- Drive, its accessories and accompanying devices should be mounted and put into operation by qualified personnel in accordance with the guidelines provided in the instruction manual.

To reduce the risk of burns, fire, electric shock, or personal injury:

- Use this drive only for its intended use as described in the instruction manual.
- Use only attachments recommended by the manufacturer or as contained in the instruction manual.
- Do not operate without corresponding protective devices.
- Never operate this drive if one or more parts (e.g. cables, plugs) are damaged, if it is not working properly, if any damages can be identified or are to be suspected (e.g. after it has been dropped). Only qualified personnel are authorized to make adjustments, eliminate faults and complete repair work.
- Never operate the drive with the air openings blocked. Keep ventilation openings of the drive free from the accumulation of lint, dust and loose cloth.
- Never drop or insert any object into any opening.
- Do not use drive outdoors.
- Do not operate where aerosol (spray) products are being used or where oxygen is being administered.
- To disconnect, turn off main switch, then remove plug from outlet.
- Do not unplug by pulling on cord. To unplug, grasp the plug, not the cord.
- Keep fingers away from all moving machine parts. Special care is required e.g. around the sewing machine needle and the V-belt.
- Before mounting and adjusting accompanying devices, i.e. position transmitter, reversing device, light barrier, etc., disconnect drive from mains (turn off main switch, remove mains plug from outlet [DIN VDE 0113 part 301; EN 60204-3-1; IEC 204-3-1]).
- Always switch off (0) machine and remove plug from outlet, when removing covers, mounting accompanying devices, position transmitter especially, light barrier, etc., or any other devices mentioned in the instruction manual.
- Only qualified personnel are authorized to work on the electrical components.

- Work on high voltage circuit areas is forbidden, except as stated in the respective regulations, e.g. DIN VDE 0105 part 1.
- Only specially trained personnel are authorized to complete repair work.
- Cables to be wired must be protected against expectable strain and fastened adequately.
- Cables near moving machine parts (e.g. V-belts) must be wired at a minimum distance of 25 mm (see DIN VDE 0113 part 301; EN 60204-3-1; IEC 204-3-1).
- For safety it is preferred to wire the cables separately from each other.
- Before connecting the mains line make sure that the mains voltage corresponds to the specifications on the motor rating plate and on the nameplate of the power pack.
- Connect this drive to a properly grounded outlet only. See Grounding Instructions.
- Electric accompanying devices and accessories must only be connected to safety low voltage.
- EFKA DC drives are protected according to overvoltage class 2 (DIN VDE 0160 § 5.3.1).
- Observe all safety guidelines before undertaking conversions or modifications.
- For repair and maintenance use only original replacement parts.



Warnings in the instruction manual which point out particular risks of personal injury or risk to the machine are marked with this symbol wherever applicable.



This symbol is a warning on the control and in the instruction manual. It indicates hazardous voltage.

CAUTION – In the case of failure this area can be current-carrying even after having turned the power off (non discharged capacitors).

- The drive is not an independently operating unit, but is designed to be incorporated into the machinery. It must not be put into service until the machinery into which it is to be incorporated has been declared in conformity with the provisions of the EC Directive.

Save these instructions for future reference.

2 Range of Applications

The drive is suitable for industrial sewing machines and sewing automats of various manufacturers.

2.1 Use in Accordance with Regulations

The drive is not an independently operating machine, but is designed to be incorporated into other machinery. It must not be put into service until the machinery into which it is to be incorporated has been declared in conformity with the provisions of the EC Directive (Appendix II, paragraph B of the Directive 89/392/EEC and supplement 91/368/EEC).

The drive has been developed and manufactured in accordance with the relevant EC standards:

EN 60204-3-1:1990 Electrical equipment of industrial machines:
 Particular requirements for industrial sewing machines, sewing units and sewing systems.

Operate the drive only:

- on thread processing machines
- in dry areas



CAUTION

When selecting the installation site and the layout of the connecting cable, the Safety Instructions in Section 1 must be followed with no exceptions. Particular attention should be paid to maintaining the proper distance from moving

3 Complete Drive Unit Consisting of

1	Direct current motor	DC1500
1	Electronic control - Power pack	AB286A5400 N202
1	Set of standard accessories consisting of:	B156 Set of hardware Documentation
1	Set of accessories consisting of cord	Z56 Potential equalization

Note

If there is no metallical contact between drive (motor) and machine head, the potential equalization cord supplied with the unit is to be wired from the machine head to the terminal provided on the control box!

3.1 Special Accessories

- | | |
|--------------------------------------------------------------------------------------------------|-----------------------------------------------------------------------|
| External actuator type EB301A with approx. 250 mm connecting cable and 9-pin SubminD plug | - part no. 4170023 |
| Extension cable for motor connection, approx. 400 mm long | - part no. 1111858 |
| Extension cable for motor connection, approx. 1500 mm long | - part no. 1111857 |
| Sewing light transformer | - please indicate line voltage and sewing light voltage (6.3V or 12V) |

4 Starting Service

Before putting the control into operation, the following must be ensured, checked and/or adjusted:

- The correct installation of the drive, the position transmitter and accompanying devices, if necessary
- The correct adjustment of the direction of rotation of the motor

5 Socket Connectors

The drive receives the commands necessary for its operation from a master computer. A socket with an RS485 interface and further signal lines is provided for that. Moreover, the control has sockets for the connection of the motor, position transmitter and external actuator.

- B2** Socket for position transmitter in the motor
- B18** Socket for 180° sensor
- B41** Socket for motor power supply
- B80** Socket for actuator
- B485** Socket for RS485 interface and further signal lines
- S1** Jumper for terminating resistor (see chapter “Activate/Deactivate Terminating Resistor“)
- Factory setting: Jumper S1 closed!

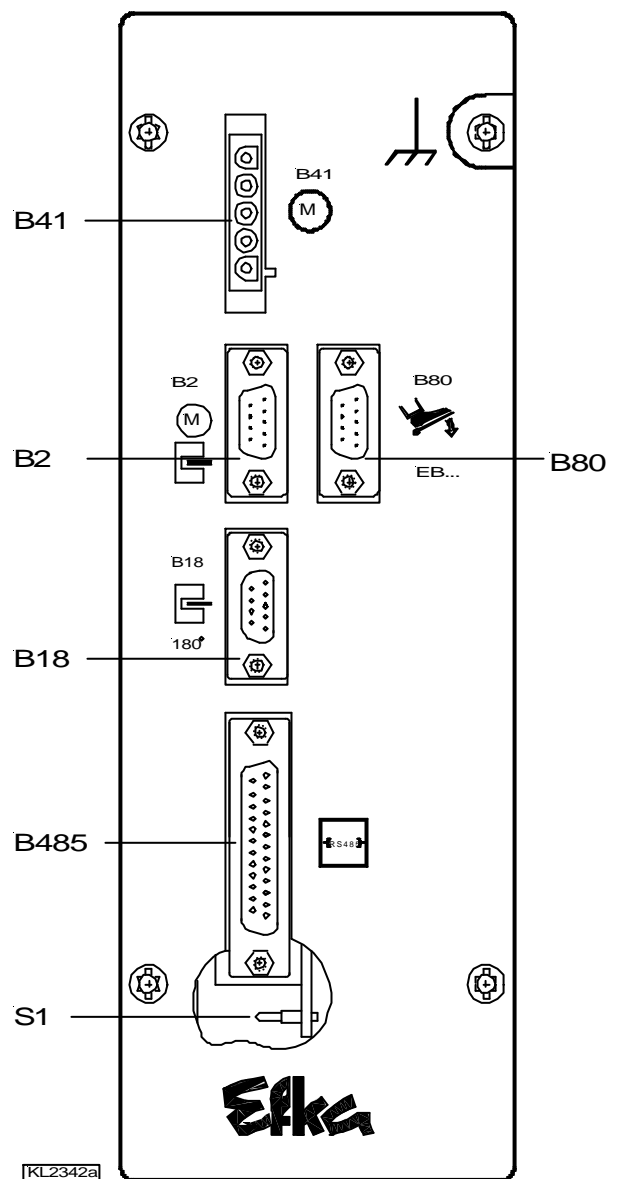

6 Connection Diagram

See chapter 15 for examples of connections!

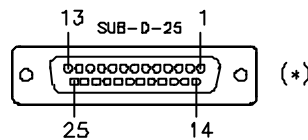
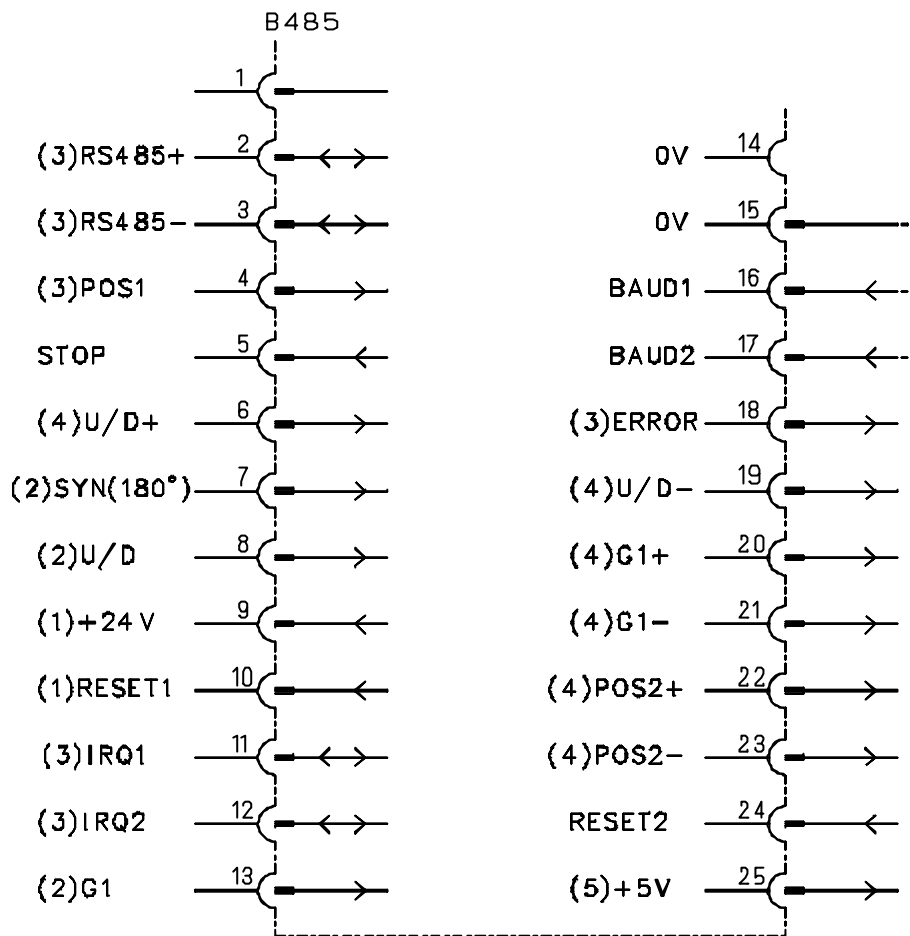

BI1161a

Symbols: → = Output ← = Input ↔ = bidirectional

Note
The connecting cable between computer and AB286A control must be shielded!

Note
All inputs and outputs of the AB286A control (socket B485) are potential-free!

- 1) RESET 1 in connection with external nominal voltage =24V, no-load voltage max. =36V
- 2) Output +5V, max. 15mA
- 3) TRI-STATE line (BUS-capable)
- 4) Differential driver outputs
- 5) Voltage +5V, I_{max} = 200mA

POS1	Counting signal position 1
POS2+ / POS2-	Differential outputs position 2
STOP	Input for stop of the drive
SYN	Synchronization window (180° track)
U/D	Direction of rotation of the position transmitter (counterclockwise = low / clockwise = high)
U/D+ / U/D-	Differential outputs of the direction of rotation of the position transmitter
RESET 1	Reset 1 (low active with $U = < 11V$)
RESET 2	Reset 2 (low active with $U = < 1.5V$)
IRQ 1	Interrupt 1 (low active)
IRQ 2	Interrupt 2 (low active)
G1	512 impulses / rotation
G1+ / G1-	Differential outputs 512 impulses / rotation
BAUD 1	Input 1 to set baud rates (low active)
BAUD 2	Input 2 to set baud rates (low active)
FEHLER	Error output

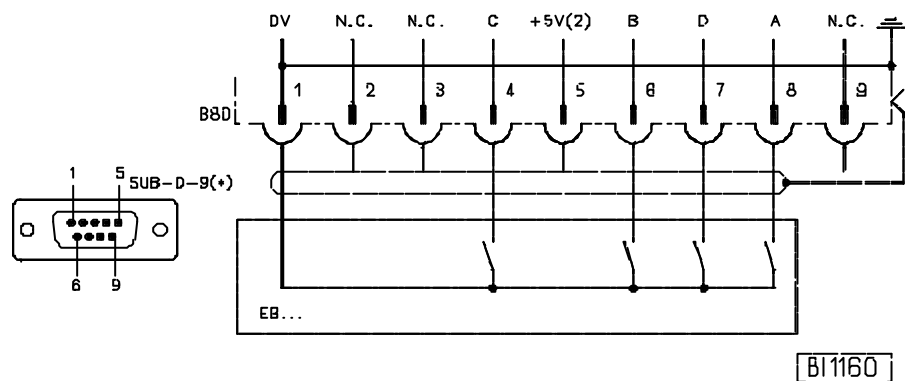

EB... Actuator

2) Voltage +5V, $I_{\max} = 200\text{mA}$

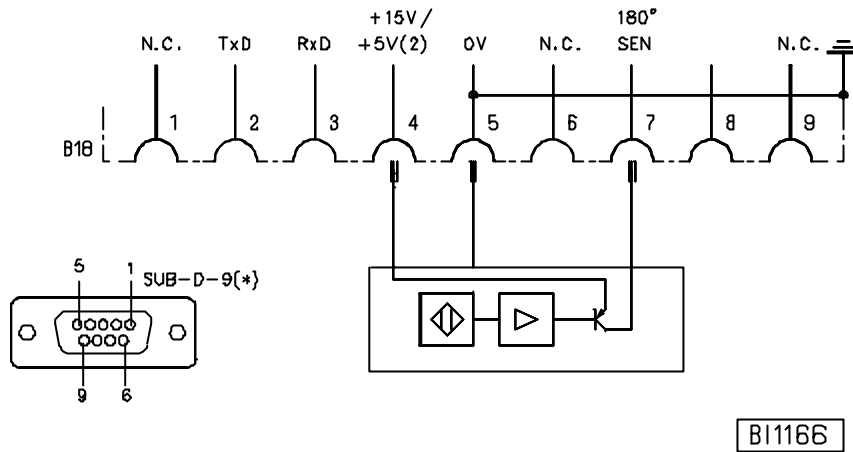

- 180° SEN External signal
- TxD/RxD No function (Do not connect anything to this socket!)

For external devices there is a supply voltage of +5V on socket B18/4. After opening the cover, this voltage can be changed to +15V by moving a multipole connector J4 to a different position on the printed circuit board.



ATTENTION!
Before opening the cover, turn power off and remove mains plug from outlet!

- +15V = Connect righthand pins 3 and 4 with jumper
- +5V = Connect lefthand pins 1 and 2 with jumper (factory setting)

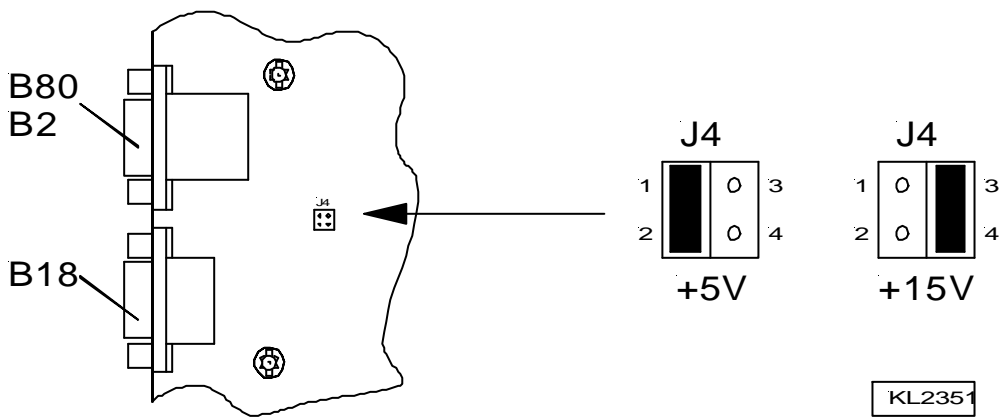

- 2) Nominal voltage +5V, 100mA (can be changed to +15V, 100mA)

7 Interface Definition

Hinweis

In the BUS system with an EFKA interface motor other modules (e. g. I/O) must have an address less than \$7F.

Note

A BUS termination resistor of 100 Ohm is provided in the control. Therefore, the control must be the last module to be connected to the RS485 BUS. If several controls are connected, see chapter "Examples of Connections".

7.1 Baud Rate Selection

Baud rate	Jumper in plug B3
125,000 Baud	All pins open
41,667 Baud	Connect pin 16 to pin 15 (0V)
31,250 Baud	Connect pin 17 to pin 15 (0V)
9,600 Baud	Connect pins 16 and 17 to pin 15 (0V)

7.2 Protocol

- Data transfer according to ISO 1745.
- Only the commands **data link establishment** and **RTS** are valid.
- The control is selected with **address \$F0** (preset value). If several controls are connected further addresses up to **\$FF** are valid.
- Data transfer in **ASCII** (see also chapter **ASCII Data Transfer**).
- One word = 10 bit (1 start bit, 8 data bits, 1 stop bit, no parity bit).

7.3 Transmit Timeout before "NAK"

After detecting an error the "NAK" acknowledgment will only be sent after a "timeout". See the following table for the length of the "timeout" depending on the baud rate.

125,000 Baud	2 ms	Timeout
41,667 Baud	3 ms	Timeout
31,250 Baud	4 ms	Timeout
9,600 Baud	10 ms	Timeout

7.4 Byte to Byte Timeout

If, in a telegram, a "timeout" is exceeded from one word to the next, "NAK" will be sent. Simultaneously, bit 6 is set in the communication register (parameter 00). See the following table for the length of the "timeout" depending on the baud rate.

125,000 Baud	6 ms	Timeout
41,667 Baud	8 ms	Timeout
31,250 Baud	10 ms	Timeout
9,600 Baud	22 ms	Timeout

7.5 Communication Monitoring (System Values D, Group E)

A “timeout” for communication monitoring can be set by means of parameter E3. This “timeout” can be set at 10-millisecond steps within a range of 0 and 255 (max. 2.5 seconds). If, in this parameter, a value not equal to zero is inputted, there must always be an RTS to or a data link establishment with the slave within the allowed time. If the “timeout” is exceeded, the drive stops in position 2 and sets bit 6 in the communication register (parameter 00). The “timeout” starts with the next telegram after the data link establishment for parameter E3. Monitoring can be deactivated by inputting the value zero in parameter E3 (preset value). Please note that the new value becomes effective only with the next telegram.

7.6 Control Characters

SOH	\$01	start of header
ADR	\$F0	address (can be set)
STX	\$02	start of text
ETX	\$03	end of text
ACK	\$06	acknowledge
NAK	\$15	not acknowledge
ENQ	\$05	enquiry
BCC		Check sum EXOR logic operation from ADR to ETX

7.7 Special Characters

=	\$3D	equals / value assignment
,	\$2C	Separator in list call
.	\$2E	Separator

7.8 Data Link Establishment

Higher level control = Master, AB286A = Slave

Master transmits	-	SOH	ADR	STX	<u>Text</u>	ETX	BCC
Slave transmits	-	ADR	ACK				If telegram o.k.
	-	ADR	NAK				In case of error

Parameters in the control are modified by the data link establishment. The Text contains the modification information.

The general form of a modification is: **Parameter = Value**.

Parameter number and corresponding range of values are described in chapter **Parameters**.

7.9 RTS

Master transmits	-	SOH	ADR	STX	<u>Text</u>	ENQ	
Slave transmits	-	SOH	ADR	STX	<u>Text</u>	ETX	BCC
	-	ADR	NAK				In case of error

The Master receives information on the control status by means of RTS. This information is transmitted in the form of status bytes. RTS only transmits the parameter number. More information on status bytes is described in chapter **Parameters**.

7.10 Text

The Text contains all default options for the modification of settings in the AB286A control or polling of operational statuses. These settings and operational statuses are described in detail in chapter **Parameters**.

7.11 Stop Input

0 = Run / 1 = Stop

The start of the drive can be suppressed or the running motor can be stopped immediately by the “stop“ signal. The drive can only be restarted after a reset (hardware or software). The stop signal must be on for at least 10ms.

7.12 Error Output

0 = Ready for operation / 1 = Error

The “error“ signal is issued whenever one of the following items applies:

- Hardware error
- Software error
- External 180° signal missing
- Commutation transmitter cord or frequency converter disturbed
- Line voltage too low
- Blocking, motor overstrained

Error description parameter 01 bit 2: If the external synchronization window is found after the command “go to reference point“, this bit will be set. The error signal is issued and the drive stops.

The error signal can be reset (hardware or software).

8 Parameters

The parameters are divided into the following groups:

- Group 0:** **Status and Control Registers**
Contain information on the actual control status.
- Group 1-4:** **Control Values**
The control values correspond to the system values after power on. They can be modified online during the functional sequence.
- Group 5-7:** **System Values**
The system values serve as basic settings which are rarely modified. These values can be programmed once and are saved after power off.
Attention: The system values cannot be modified during sewing.
- Group E:** **Operational Statuses**
The actual operational statuses can be read out here, e. g. actual counter reading or actual speed.
- Group F:** **Characteristics**
Contain information on the control, e. g. software version and module address.

<u>Group 0</u>		
Parameter 00 - Communication Byte		
Bit 0	= 1	In response to an RTS a list of parameter settings is transmitted (see chapter ASCII Data Transfer)
Bit 1	= 0	Reserved (must always be 0)
Bit 2	= 1	Overflow in data link establishment (parameter value above or below setting range)
Bit 3	= 1	Access not authorized
Bit 4	= 1	Noise error in communication
Bit 5	= x	Reserved
Bit 6	= 1	Timeout error in communication
Bit 7	= 1	Block check error (BCC) in communication

Bits 0 and 1 can be overwritten and read. All others can only be read.

Parameter 01 - Error Byte		
Bit 0	= 1	Hardware error
Bit 1	= 1	Software error
Bit 2	= 1	External 180° signal missing
Bit 3	= 1	Commutation transmitter cord or frequency converter disturbed
Bit 4	= 1	Line voltage too low
Bit 5	= 1	Blocking, motor overstrained
Bit 6	= 1	Parameter does not exist
Bit 7	= 1	Transmission is temporarily interrupted

Parameter 02 - Status Byte 1		
Bit 0	= 1	Motor at standstill
Bit 1	= 1	Speed has been reached
Bit 2	= 1	Position has been reached
Bit 3	= 1	Is in position 2
Bit 4	= 1	Is in position 1
Bit 5	= 1	Drive is ready (after RESET)
Bit 6	= 1	Reference point has been reached
Bit 7	= 1	Position transmitter synchronized

Parameter 03 - Status Byte 2		
Bit 0	= 1	Position 1E has been reached (E = leading)
Bit 1	= 1	Position 1A has been reached (A = trailing)
Bit 2	= 1	Position 2E has been reached
Bit 3	= 1	Position 2A has been reached
Bit 4	= 1	Position 3E has been reached
Bit 5	= 1	Position 3A has been reached
Bit 6	= 1	180° window has been reached
Bit 7	= 1	Reserved

Parameter 04 - Control Byte 1		
Bit 0	= 1	Triggers a software reset
Bit 1	= 1	Direction of rotation cw
Bit 3/2	= 00	Speed 1 (Parameter 10)
	= 01	Speed 2 (Parameter 11)
	= 10	Speed 30 (Parameter 63)
	= 11	Speed 40 (Parameter 64)
Bit 6-4	= 000	Motor operation
	= 001	Fast stop (unpositioned)
	= 010	Stop in position 1
	= 011	Stop in position 2
	= 100	Stop in position 3
	= 111	Release the pedal
Bit 7	= 1	Go to reference point

Parameter 05 - Control Byte 2		
Bit 0	= 1	Single impulse of position 2
Bit 1	= 1	Double speed (Attention: speed has been increased in steps of 4 RPM. This does not apply to the positioning speed)
Bit 2	= 1	Disable accurate positioning
Bit 3-4	= 00	Stop with pedal in position 0 (neutral) → unpositioned (preset)
	= 01	Stop with pedal in position 0 (neutral) → position 1
	= 10	Stop with pedal in position 0 (neutral) → position 2
	= 11	Stop with pedal in position 0 (neutral) → position 3
Bit 5		Limit speed to the value set in parameter 64 (speed 40)
Bit 6		Enable control byte 03 (bits 3-4 will be blocked)
Bit 7		Reserved

Parameter 06 - Status Byte 3		
Bit 0-1	= 00	Stop with pedal in position -1 → unpositioned (preset)
	= 01	Stop with pedal in position -1 → position 1
	= 10	Stop with pedal in position -1 → position 2
	= 11	Stop with pedal in position -1 → position 3
Bit 2-3	= 00	Stop with pedal in position -2 → unpositioned (preset)
	= 01	Stop with pedal in position -2 → position 1
	= 10	Stop with pedal in position -2 → position 2
	= 11	Stop with pedal in position -2 → position 3
Bit 4-5	= 00	Stop with pedal in position 0 (neutral) → unpositioned (preset)
	= 01	Stop with pedal in position 0 (neutral) → position 1
	= 10	Stop with pedal in position 0 (neutral) → position 2
	= 11	Stop with pedal in position 0 (neutral) → position 3
Bit 6-7	= 00	Stop with pedal in position +1 → unpositioned (preset)
	= 01	Stop with pedal in position +1 → position 1
	= 10	Stop with pedal in position +1 → position 2
	= 11	Stop with pedal in position +1 → position 3

Parameter 08 - Status Byte 3		
Bit 0	= 1	Pedal contact A closed
Bit 1	= 1	Pedal contact B closed
Bit 2	= 1	Pedal contact C closed
Bit 3	= 1	Pedal contact D closed
Bit 4	= 1	Pedal in position -2
Bit 5	= 1	Pedal in position -1
Bit 6	= 1	Pedal in off-position
Bit 7	= 1	Pedal pressed forward

Parameter 0A - Status Byte 3		
Bit 0		Reserved
Bit 1	= 1	Counting direction from motor to handwheel inverted
Bit 2-7		Reserved

Parameter 0F - Interrupt Control Byte		
Bit 0	= 1	Receive interrupt line 1 (IRQ1)
Bit 1	= 1	Transmit interrupt line 1
Bit 2	= 1	Receive interrupt line 2 (IRQ2)
Bit 3	= 1	Transmit interrupt line 2
Bit 5/4	= 00	IRQ1 delay with counter 1 (parameter 4C)
	= 01	IRQ1 delay with counter 1, then with timer 1 (parameter 4D)
	= 10	IRQ1 delay with timer 1, then with counter 1
	= 11	IRQ1 delay with timer 1
Bit 7/6	= 00	IRQ2 delay with counter 2 (parameter 4E)
	= 01	IRQ2 delay with counter 2, then with timer 2 (parameter 4F)
	= 10	IRQ2 delay with timer 2, then with counter 2
	= 11	IRQ2 delay with timer 2

The function of the interrupt control is described in chapter **Interrupt Control** !

Group 1	Control Value A	
Parameter 10	- Speed 01	Speed 1 in [2 RPM] (with control byte 2 bit 1 = 1, then [4 RPM])
Parameter 11	- Speed 02	Speed 2 in [2 RPM] (with control byte 2 bit 1 = 1, then [4 RPM])
Parameter 12	- Positioning speed	Positioning speed at [2 RPM]
Parameter 17	- Braking power	Braking power at standstill (value changeable from 0 to 30). After RESET parameter 57 will be read as preset value.
Parameter 18	- Ramp 1	Accelerating ramp [1/min * ms]
Parameter 19	- Ramp 2	Slowing down to intermediate speed [1/min * ms]
Parameter 1A	- Ramp 3	Slowing down for positioning [1/min * ms]
Parameter 1B	- Ramp 4	Positioning intensity

Group 4	Control Value D	
Parameter 4C	- Stitch counter IRQ1	Stitch delay for transmitting or receiving interrupt line 1
Parameter 4D	- Timer IRQ1	Time delay for transmitting or receiving interrupt line 1
Parameter 4E	- Stitch counter IRQ2	Stitch delay for transmitting or receiving interrupt line 2
Parameter 4F	- Timer IRQ2	Time delay for transmitting or receiving interrupt line 2

Group 5	System Value A	
Parameter 50	- Position 1E	Position 1 leading edge
Parameter 51	- Position 1A	Position 1 trailing edge
Parameter 52	- Position 2E	Position 2 leading edge
Parameter 53	- Position 2A	Position 2 trailing edge
Parameter 54	- Position 3E	Position 3 leading edge
Parameter 55	- Position 3A	Position 3 trailing edge
Parameter 56	- Syn. signal	0 = The reference point is generated by the transmitter in the motor 1 = Falling edge of the ext. sensor with positive counting direction is the reference point 2 = Increasing edge of the ext. sensors with positive counting direction is the reference point
Parameter 57	- Braking power	Preset value for braking power at standstill (preset value = 0; i. e. braking at standstill is not effective)
Parameter 58	- Ramp 1	Accelerating ramp [1/min * ms] Is transferred to ramp 1 in case of reset. (parameter 18)
Parameter 59	- Ramp 2	Slowing down to intermediate speed [1/min * ms] Is transferred to ramp 2 in case of reset. (parameter 19)
Parameter 5A	- Ramp 3	Slowing down for positioning [1/min * ms] Is transferred to ramp 3 in case of reset. (parameter 1A)
Parameter 5C	- Ramp 4	Positioning intensity Is transferred to ramp 4 in case of reset. (parameter 1B)

Group 6	Control Value B	
Parameter 60	- Direction of rotation	Direction of rotation of the motor ccw = 0, cw = 1
Parameter 61	- Speed 10	Contents is transferred to the control byte in case of reset Speed 10 in [2 RPM] (with control byte 2 bit 1 = 1, then [4 RPM]) Is transferred to speed 1 in case of reset. (parameter 10)
Parameter 62	- Speed 20	Speed 20 at [2 RPM] (with control byte 2 bit 1 = 1, then [4 RPM]) Is transferred to speed 2 in case of reset. (parameter 11)
Parameter 63	- Speed 30	Speed 30 at [2 RPM] (with control byte 2 bit 1 = 1, then [4 RPM])
Parameter 64	- Speed 40	Speed 40 at [2 RPM] (with control byte 2 bit 1 = 1, then [4 RPM])
Parameter 65	- Maximum speed	The speed is internally limited to this value
Parameter 66	- Positioning speed	Positioning speed at [2 RPM] Is transferred to positioning speed in case of reset. (parameter 12)

Group 7		System Values C
Parameter 70	- P-divisor	Dividing factor P-controller for adapting the running behavior to the machine
Parameter 71	- I-divisor	Dividing factor I-controller for adapting the running behavior to the machine
Parameter 72	- Stop segment	Number of increments before stop position

Group E		System Values D
Parameter E0	- Actual counter reading	The actual counter reading of the position transmitter can be read out. After a reset synchronization is necessary. Use command "go to reference
Parameter E1	- Actual speed	The actual speed can be read out. It is issued at 2/min. The value must thus be multiplied by 2.
Parameter E2	- Run-out stop segment	Number of increments after stop position.
Parameter E3	- Communication monitoring	Timeout between the transfers. If the preset time is exceeded, the drive stops in position 2 and sets bit 6 in the communication byte (0 = funktion disabled).

Group F		Characteristics
Parameter F0	- Entry 1	2 bytes as for ex. serial number can be entered here
Parameter F1	- Entry 2	2 bytes as for ex. workplace number can be entered here
Parameter F2	- Operating hours	2-byte operating hours.
Parameter F3	- Entry 3	2 bytes as for ex. repair note can be entered here
Parameter FA	- P.c.b. no.	Main board number
Parameter FB	- Control box no.	Control box number
Parameter FC	- Efka type	Type number with state of development
Parameter FD	- Efka date code	ID code
Parameter FE	- Software version	Program number with modification index
Parameter FF	- Address	The address of the AB286A control is filed here (preset = F0)

8.1 Special Features

When setting the speeds (parameters 10, 11, 61, 62, 63 and 64), half the value must be transmitted, i.e. the value "2000" [2 RPM] must be transmitted for a requested speed of 4000 [RPM].

8.2 Bit Descriptions

8.2.1 "RDY" Bit 5 in Status Byte 1

The "ready bit" will not be set in case of the following errors:

0 = Error, as described below / 1 = Ready for operation

- Hardware error
- Software error
- Position transmitter not connected or defective
- Commutation transmitter cord or frequency converter disturbed
- Line voltage too low
- Blocking, motor overstrained

8.2.2 “NPE“ Bit 6 in Status Byte 1

This status bit will be set if the drive is within a window of +/- 8 increments around the reference point after the command “go to reference point”. When leaving this range, the bit will be erased. The drive goes to the reference point in conjunction with control byte 1 bit 7 and the positioning speed (parameter 12). In order to stop exactly at the reference point the positioning speed should be as low as possible.

8.2.3 “P1E, P1A, P2E, P2A, P3E, P3A“ in Status Byte 2

Status bits “PxE“ with increasing edge and “PxA“ with falling edge will be set for the corresponding position. These bits are preserved until the next change of status of the respective position. Furthermore, the bits can be used for triggering an interrupt (synchronization with position...).

8.2.4 “PSYN“ Bit 7 in Status Byte 1

This status bit is set after the position transmitter has been synchronized. Then the value in parameter E0 as well as all other status signals of the positions are valid.

8.2.5 “P2T“ Bit 0 in Control Byte 2

If this bit has been set, a single impulse (LOW – HIGH – LOW) is issued at the output of position 2. This command will only be executed at standstill. The bit is reset after issuing this impulse or whenever the drive has not stopped.

8.2.6 “2N“ Bit 1 in Control Byte 2

If this bit is set, the speeds are doubled. The quadruple speed must now be transmitted. Internally, the speed is limited to 10000 RPM. The positioning speed will not be doubled.

Control Byte 2	bit 1 = 0	➔	double speed
Control Byte 2	bit 1 = 1	➔	quadruple speed

8.2.7 “ZSTP_“ Bit 2 in Control Byte 2

If this bit is set, accurate positioning is disabled. The drive stops out of the positioning speed (parameter 68).

8.2.8 “PNLIM“ Bit 5 in Control Byte 2

At this setting the speed is limited if the pedal speed is higher. The pedal speed has priority if it is lower than this limit.

8.3 Functional Descriptions

8.3.1 Stop Segment Angle for Positioning (System -values C, Group 7)

An angle with which the stop point can be moved backward depending upon the set stop position can be set by means of parameter 72. The positions (1E, 1A, 2E, 2A, 3E, 3A) will not be changed.

The preset value for parameter 72 is 0. The maximum value is 50 increments (e. g. $50 * 1.4^\circ = 71.1^\circ$) and can be changed in single increments. Transmission is done at 2 bytes.

8.3.2 Run-Out Angle for Positioning (System Values D, Group E)

An angle with which the stop point can be moved forward depending upon the set stop position can be set by means of parameter E2. The positions (1E, 1A, 2E, 2A, 3E, 3A) will not be changed. The preset value for parameter E2 is 6. The maximum value is 25 increments and can be changed in single increments (i. e. $25 * 1.4^\circ = 35^\circ$). Transmission is done at 2 bytes.

8.3.3 Accurate Positioning

Accurate positioning is time-optimized and reproducible. Ensure that the value of ramp 3 (the preset value in parameter 1A corresponds to the value in parameter 5A) is lower than the maximum braking ramp determined by the system (3 to 5 [1/min * ms] lower than the maximum value). In order to determine the maximum braking ramp, set the value of ramp 3 to the maximum (255). The value for ramp 3 is the quotient of speed and braking time (in ms).

In the example, the ramp is the quotient of speed change / time.

$$4500 \text{ [1/min]} / 150 \text{ [ms]} = 30 \text{ [1/min * ms]}$$

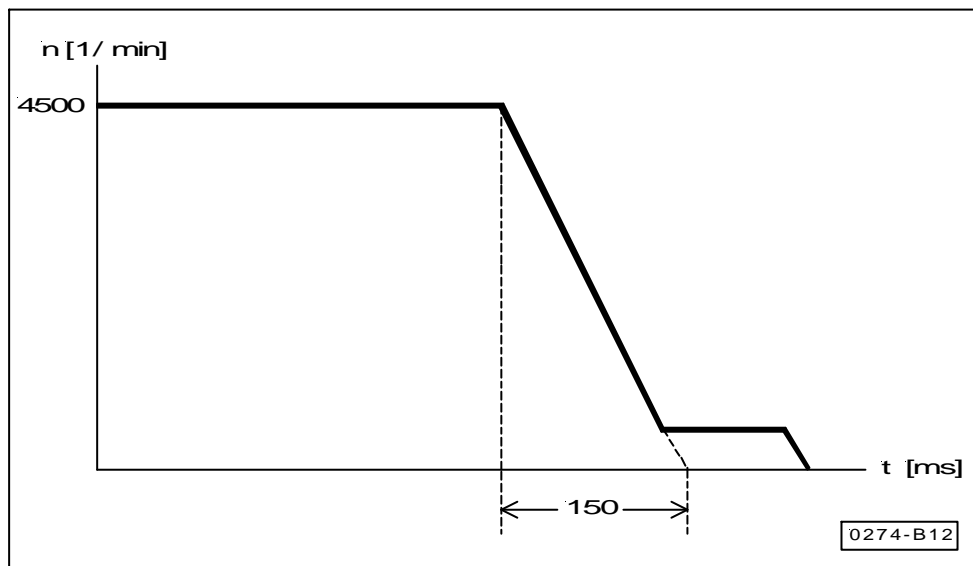

8.4 Table of Parameters

Values – Ranges – Preset (all data in decimal and hexadecimal form = \$xxx)

Group	No.	Description	MINIMUM		MAXIMUM		PRESET		STEP
			HEX	DEC	HEX	DEC	HEX	DEC	
1	10	Speed 1, [2 RPM]	\$023	35	\$DAC	3500	Speed 10		1
1	11	Drehzahl 2, [2 RPM]	\$023	35	\$DAC	3500	Speed 20		1
1	12	Positioning speed	\$23	35	\$FA	250	Parameter 68		1
1	17	Braking power at standstill	\$00	0	\$32	50	Parameter 57		1
1	18	Ramp 1 [1/min*ms]	\$01	1	\$37	55	Parameter 58		1
1	19	Ramp 2 [1/min*ms]	\$01	1	\$37	55	Parameter 59		1
1	1A	Ramp 3 [1/min*ms]	\$01	1	\$37	55	Parameter 5A		1
1	1B	Ramp 4 [1/min*ms]	\$01	1	\$37	55	Parameter 5C		1
4	4C	Stitch counter IRQ1	\$00	0	\$FF	255	\$00	0	1
4	4D	Timer IRQ1 [5ms]	\$00	0	\$FF	255	\$00	0	1
4	4E	Stitch counter IRQ2	\$00	0	\$FF	255	\$00	0	1
4	4F	Timer IRQ2 [5ms]	\$00	0	\$FF	255	\$00	0	1
5	50	Position 1E	\$00	0	\$FF	255	\$80	128	1
5	51	Position 1A	\$00	0	\$FF	255	\$8A	138	1
5	52	Position 2E	\$00	0	\$FF	255	\$00	0	1
5	53	Position 2A	\$00	0	\$FF	255	\$0A	10	1
5	54	Position 3E	\$00	0	\$FF	255	\$C0	12	1
5	55	Position 3A	\$00	0	\$FF	255	\$CA	202	1
5	56	Synchronization signal	\$00	0	\$FF	255	\$00	0	1
5	57	Braking power ar standstill	\$00	0	\$32	50	\$00	0	1
5	58	Ramp 1 [1/min *ms]	\$01	1	\$37	55	\$1C	28	1
5	59	Ramp 2 [1/min *ms]	\$01	1	\$37	55	\$14	20	1
5	5A	Ramp 3 [1/min *ms]	\$01	1	\$37	55	\$1C	28	1
5	5C	Ramp 4 [1/min *ms]	\$01	1	\$37	55	\$0A	10	1
6	60	Direction of rotation	\$00	0	\$01	1	\$00	0	1
6	61	Speed 10	\$023	35	\$DAC	3500	\$8CA	2250	1
6	62	Speed 20	\$023	35	\$DAC	3500	\$190	400	1
6	63	Speed 30	\$023	35	\$DAC	3500	\$2FE	766	1
6	64	Speed 40	\$023	35	\$DAC	3500	\$4E2	1250	1
6	65	Maximum speed	\$023	35	\$DAC	3500	\$BB8	3000	1
6	66	Positioning speed	\$23	35	\$FA	250	\$5A	90	1
7	70	P-divisor	\$01	1	\$14	20	\$04	10	1
7	71	I-divisor	\$01	1	\$28	40	\$06	6	1
7	72	Stop segment	\$00	0	\$32	50	\$06	6	1
E	E0	Read out actual position	\$00	0	\$FF	255	---		-
E	E1	Read out speed	\$0000	0	\$0FFF	4095	---		-
E	E2	Run-out angle	\$00	0	\$32	50	\$06	6	1
E	E3	Communication monitoring	\$00	0	\$FF	255	\$00	0	1
F	F0	Entry 1 (serial no.)	\$0000	0	\$FFFF	65535	\$0000	0	1
F	F1	Entry 2 (workplace)	\$0000	0	\$FFFF	65535	\$0000	0	1
F	F2	Operating hours	\$0000	0	\$FFFF	65535	\$0000	0	1
F	F3	Entry 3 (repair note)	\$0000	0	\$FFFF	65535	\$0000	0	1
F	FA	P.c.b. no.	Text 12		Text 12		-----		-
F	FB	Control box no.	Text 8		Text 8		-----		-
F	FC	Efka type	Text 8		Text 8		-----		-
F	FD	Efka date code	Text 8		Text 8		-----		-
F	FE	Software version	Text 8		Text 8		-----		-
F	FF	Module address	\$F0	240	\$FF	255	\$F0	240	1

Group	No.	Description	Bit	7	6	5	4	3	2	1	0
0	00	Communication byte	BCC	TIM	---	NOI	ZUG	BER	---	LST	
0	01	Error byte	X0F	PNV	BLCK	NETZ	---	---	SOFT	HARD	
0	02	Status byte 1	PSYN	NPE	RDY	P01	P02	P0E	DZE	STP	
0	03	Status byte 2	---	180	P3A	P3E	P2A	P2E	P1A	P1E	
0	04	Control byte 1	NPA	STP3	STP2	STP1	V2	V1	DRI	RES	
0	05	Control byte 2	---	---	PNLIM	PDST2	PDST1	ZSTP_	2N	P2T	
0	08	Status byte 3	PED+	PED0	PED-1	PED-2	PEDD	PEDC	PEDB	PEDA	
0	0A	Status byte 3	---	---	---	---	---	---	CNTD	---	
0	0F	Interrupt control byte	TIQ2	ZIQ2	TIQ1	ZIQ1	SIQ2	EIQ2	SIQ1	EIQ1	

BCC = Block check error	P02 = Is in position 2	ZSTP_ = Disable accurate stop
TIM = Timeout error	POE = Position reached	2N = Double speed
NOI = Noise error	DZE = Speed reached	P2T = Single impulse of position 2
ZUG = Access not authorized	STP = Motor at standstill	PED+ = Pedal pressed forward
BER = Overflow	180 = 180° window reached	PED0 = Pedal in off-position
LST = List is issued	P3A = Position 3A reached	PED-1 = Pedal position -1
XOF = Transmission interrupted	P3E = Position 3E reached	PED-2 = Pedal position -2
PNV = Parameter does not exist	P2A = Position 2A reached	PEDD = Pedal contact D closed
BLCK = Motor overstrained, blocked	P2E = Position 2E reached	PEDC = Pedal contact C closed
NETZ = Line voltage too low	P1A = Position 1A reached	PEDB = Pedal contact B closed
SOFT = Software error	P1E = Position 1E reached	PEDA = Pedal contact A closed
HARD = Hardware error	NPA = Go to reference point	TIQ2 = Timer bit IRQ2
PSYN = Position transmitter synchronized	STP3 = Stop bit 3	ZIQ2 = Counter bit IRQ2
NPE = Reference point reached	STP2 = Stop bit 2	TIQ1 = Timer bit IRQ1
RDY = Drive is ready	STP1 = Stop bit 1	ZIQ! = Counter bit IRQ1
P01 = Is in position 1	V2 = Speed bit 2	SIQ2 = Transmit IRQ2
PNLIM = Limited speed (using pedal)	V1 = Speed bit 1	EIQ2 = Receive IRQ2
PDST1 = Pedal stop bit 1	DRI = Direction of rotation	SIQ1 = Transmit IRQ1
PDST2 = Pedal stop bit 2	RES = Software reset	EIQ1 = Receive IRQ1
CNTD = Counting direction		

9 ASCII Data Transfer

The complete transfer of a protocol is done in ASCII.

Example: Parameter 61 = \$8CA = 2250 2RPM (speed 10 = 4500 RPM)

ASCII value	of 6	=	54 decimal	=	\$36 hexadecimal
	of 1	=	49 decimal	=	\$31 hexadecimal
	of (=)	=	61 decimal	=	\$3D hexadecimal
	of 8	=	56 decimal	=	\$38 hexadecimal
	of C	=	67 decimal	=	\$43 hexadecimal
	of A	=	65 decimal	=	\$41 hexadecimal

The data link establishment for parameter 61 = \$8CA must therefore be as follows:

SOH	ADR	STX	(6	1	=	8	C	A)	ETX	BCC
\$01	\$F0	\$02	\$36	\$31	\$3D	\$38	\$43	\$41	\$03	\$F1

10 List Call

All marginal conditions of each parameter can be queried by a list call.

Group	No.	Description	Bit	7	6	5	4	3	2	1	0
0	00	Communication byte		BCC	TIM	---	NOI	ZUG	BER	---	LST

The value of a parameter is transmitted back to the master by RTS.

Example:

Master transmits	SOH	ADR	STX	(parameter no.)	ENQ	
Slave transmits	SOH	ADR	STX	(parameter = value)	ETX	BCC

If, however, bit **LST** is set to 1 in the communication byte before RTS, not only the value of the parameter but also all marginal conditions will be transmitted in the form of a list.

Example:

Master transmits	SOH	ADR	STX (communication byte = xxxxxxx1)	ETX	BCC
Slave transmits	ADR	ACK	If telegram o.k.		
	ADR	NAK	In case of error		

Thus bit **LST** is set to 1 in the communication byte.

Then the master requests RTS:

Master transmits	SOH	ADR	STX	(parameter no.)	ENQ	
Slave transmits	SOH	ADR	STX	(LIST)	ETX	BCC

A list is always transmitted in response to RTS until the master resets bit **LST** in the communication byte.

LIST means in this case:

Parameter = Value, Minimum, Maximum, Step, Preset, Access Authorization

The list values are separated by commas (ASCII \$2C)!

12 Examples for Serial Data Transfer

12.1 Power On

Before power on, ensure that the right baud rate has been selected by jumpers in the plug. After power on and/or restart, the control needs approx. 2 seconds to be ready for operation. This status is signalled by **bit 5 in status byte 1**.

Group	No.	Description	Bit 7	6	5	4	3	2	1	0
0	02	Status Byte 1	PSYN	NPE	RDY	P01	P02	POE	DZE	STP

Example:		Query for readiness for operation after power on (RTS parameter 2)								
Master transmits		SOH	ADR	STX	(\$30 \$32)					ENQ
Slave transmits		SOH	ADR	STX	(\$30 \$32 \$3D \$xx \$xx)				ETX	BCC
The master recognizes the readiness for operation from bit 5.										

12.2 Operation

Example: Sequence of the speed profile below.

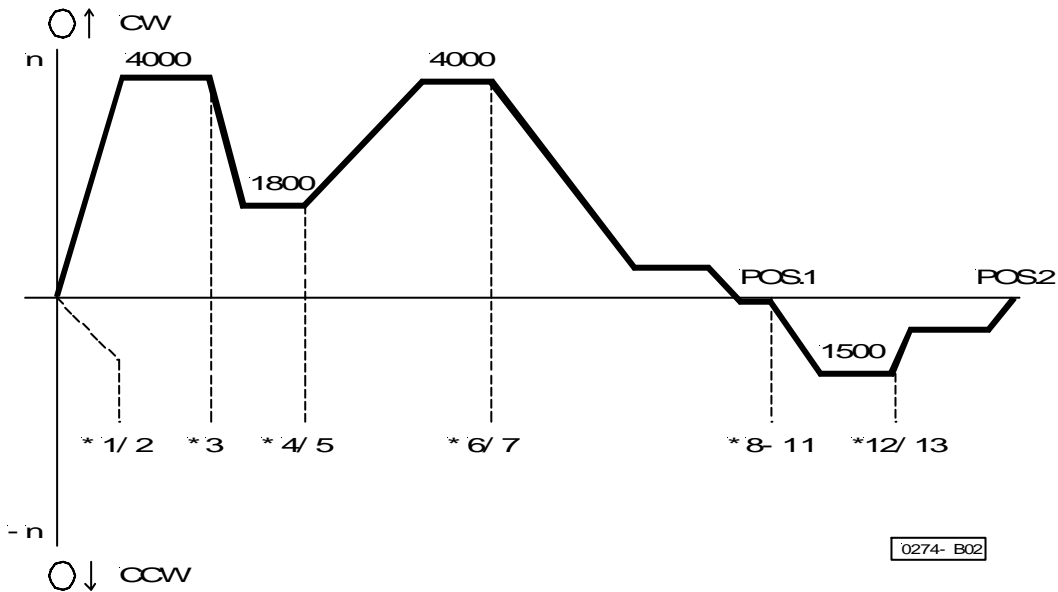

* = Step

Step 1	Determine speed 1 = 4000 [RPM]				Control value A Parameter 10 = 2000 [2 RPM]					
Master		SOH	ADR	STX	(\$31 \$30 \$3D \$37 \$44 \$30)				ETX	BCC
Slave	ADR	ACK								

Step 2		Drive operation. Default options by means of control byte 04						
	No reset			Control Byte 04	Bit 0	- RES	= 0	
	Determine direction of rotation				Bit 1	- DRI	= 0	
	Select speed 1				Bit 2	- V1	= 0	
					Bit 3	- V2	= 0	
	Motor operation				Bit 4	- STP1	= 0	
					Bit 5	- STP2	= 0	
					Bit 6	- STP3	= 0	
	Do not go to reference point				Bit 7	- NPA	= 0	
Master	SOH	ADR	STX	(\$30 \$34 \$3D \$30 \$30)		ETX	BCC	
Slave	ADR	ACK						

Drive runs at 4000 RPM

Step 3		Determine speed 1 = 1800 [RPM]			Control value A Parameter 10 = 900 [2 RPM]		
Master	SOH	ADR	STX	(\$31 \$30 \$3D \$33 \$38 \$34)		ETX	BCC
Slave	ADR	ACK					

Drive runs at 1800 RPM

Step 4		Reduce acceleration			Control value A Parameter 18 = 10		
Master	SOH	ADR	STX	(\$31 \$38 \$3D \$30 \$41)		ETX	BCC
Slave	ADR	ACK					

Step 5		Determine speed 1 = 4000 [RPM]			Control value A Parameter 10 = 2000 [2 RPM]		
Master	SOH	ADR	STX	(\$31 \$30 \$3D \$37 \$44 \$30)		ETX	BCC
Slave	ADR	ACK					

The drive accelerates with flat edge to 4000 RPM

Step 6		Reduce braking ramp 3			Control value A Parameter 1A = 10		
Master	SOH	ADR	STX	(\$31 \$41 \$3D \$30 \$41)		ETX	BCC
Slave	ADR	ACK					

Step 7		Drive is to stop in position 1. Default options by means of control byte 04						
	No reset			Control Byte 04	Bit 0	- RES	= 0	
	Determine direction of rotation				Bit 1	- DRI	= 0	
	Select speed 1				Bit 2	- V1	= 0	
					Bit 3	- V2	= 0	
	Drive is to stop in pos. 1				Bit 4	- STP1	= 0	
					Bit 5	- STP2	= 1	
					Bit 6	- STP3	= 0	
	Do not go to reference point				Bit 7	- NPA	= 0	
Master	SOH	ADR	STX	(\$30 \$34 \$3D \$32 \$30)		ETX	BCC	
Slave	ADR	ACK						

The drive moves to position 1 while braking slightly and then stops.

Step 8		Determine speed 1 = 1500 [RPM]			Control value A Parameter 10 = 750 [2 RPM]		
Master	SOH	ADR	STX	(\$31 \$30 \$3D \$32 \$45 \$45)		ETX	BCC
Slave	ADR	ACK					

Step 9	Increase acceleration			Control value A Parameter 18 = 30		
Master	SOH	ADR	STX	(\$31 \$38 \$3D \$31 \$45)	ETX	BCC
Slave	ADR	ACK				

Step 10	Increase braking ramp 3			Control value A Parameter 1A = 80		
Master	SOH	ADR	STX	(\$31 \$41 \$3D \$35 \$30)	ETX	BCC
Slave	ADR	ACK				

Step 11	Drive is to run in the opposite direction of rotation. Default options by means of control byte 04					
	No reset		Control Byte 04	Bit 0	- RES	= 0
	Change direction of rotation			Bit 1	- DRI	= 1
	Select speed 1			Bit 2	- V1	= 0
				Bit 3	- V2	= 0
	Drive operation			Bit 4	- STP1	= 0
				Bit 5	- STP2	= 0
				Bit 6	- STP3	= 0
	Do not go to reference point			Bit 7	- NPA	= 0
Master	SOH	ADR	STX	(\$30 \$34 \$3D \$30 \$32)	ETX	BCC
Slave	ADR	ACK				

The drive runs in the opposite direction of rotation at 1500 [RPM]

Step 12	Drive is to stop in position 2. Default options by means of control byte 04					
	No reset		Control Byte 04	Bit 0	- RES	= 0
	Change direction of rotation			Bit 1	- DRI	= 1
	Select speed 1			Bit 2	- V1	= 0
				Bit 3	- V2	= 0
	Drive is to stop in pos. 2			Bit 4	- STP1	= 1
				Bit 5	- STP2	= 1
				Bit 6	- STP3	= 0
	Do not go to reference point			Bit 7	- NPA	= 0
Master	SOH	ADR	STX	(\$30 \$34 \$3D \$33 \$32)	ETX	BCC
Slave	ADR	ACK				

Step 13	Query as to whether drive has reached the position. Query by means of status byte 02					
Master	SOH	ADR	STX	(\$30 \$32)	ENQ	
Slave	SOH	ADR	STX	(\$30 \$32 \$3D \$xx \$xx)	ETX	BCC

The status can be evaluated by the master control.

The query of the status byte requires constant polling by the master.

In order to avoid this, the slave must be requested to signal by interrupt when the position is reached.

Step A	Interrupt Timer IRQ1			Set parameter 4D to 20 ms		
Master	SOH	ADR	STX	(\$34 \$44 \$3D \$31 \$34)	ETX	BCC
Slave	ADR	ACK				

Example: Reaching the position is signalled by interrupt after a delay of 20ms

Step B		Provide interrupt line 1 for slave by means of control byte 0F					
	No reception IRQ1			Interrupt Byte 0F	Bit 0	- EIQ1	= 0
	Transmit on IRQ1				Bit 1	- SIQ1	= 1
	No reception IRQ2				Bit 2	- EIQ2	= 0
	No transmission IRQ2				Bit 3	- SIQ2	= 0
	With delay IRQ1				Bit 4	- ZIQ1	= 1
					Bit 5	- TIQ1	= 1
	Without delay IRQ2				Bit 6	- ZIQ2	= 0
					Bit 7	- TIQ2	= 0
Master	SOH	ADR	STX	(\$30 \$46 \$3D \$33 \$32)		ETX	BCC
Slave	ADR	ACK					

Step C		Selection of bit 2 in status byte 1 for triggering the interrupts, when position is reached.					
Master	SOH	ADR	STX	(\$30 \$32 \$3D \$30 \$34)		ETX	BCC
Slave	ADR	ACK					

Step D		Drive is to stop in position 2. Default options by means of control byte 04					
	No reset			Control Byte 04	Bit 0	- RES	= 0
	Change direction of rotation				Bit 1	- DRI	= 1
	Select speed 1				Bit 2	- V1	= 0
					Bit 3	- V2	= 0
	Drive is to stop in pos. 2				Bit 4	- STP1	= 1
					Bit 5	- STP2	= 1
					Bit 6	- STP3	= 0
	Do not go to reference point				Bit 7	- NPA	= 0
Master	SOH	ADR	STX	(\$30 \$34 \$3D \$33 \$32)		ETX	BCC
Slave	ADR	ACK					

When bit 2 in status byte 1 changes from 0 to 1, time IRQ1 = 20ms starts and interrupt IRQ1 is triggered by the slave.

The master can identify without polling whether the position has been reached, by receiving interrupt 1.

13 Position Settings

Group	No.	Description	MINIMUM	MAXIMUM	PRESET	STEP
5	50	Position 1E	\$00	\$FF	\$80	1
5	51	Position 1A	\$00	\$FF	\$8A	1
5	52	Position 2E	\$00	\$FF	\$00	1
5	53	Position 2A	\$00	\$FF	\$0A	1
5	54	Position 3E	\$00	\$FF	\$C0	1
5	55	Position 3A	\$00	\$FF	\$CA	1

Group	No.	Description	Bit 7	6	5	4	3	2	1	0
0	02	Status Byte 1	PSYN	NPE	RDY	P01	P02	P0E	DZE	STP
0	03	Status Byte 2		180	P3A	P3E	P2A	P2E	P1A	P1E
0	04	Control Byte	NPA	STP3	STP2	STP1	V2	V1	DRI	RES

PSYN	=	Position transmitter synchronized 180	=	180° window reached	STP3	=	Stop bit 3	
NPE	=	Reference point reached	P3A	=	Position 3A reached	STP2	=	Stop bit 2
RDY	=	Drive is ready	P3E	=	Position 3E reached	STP1	=	Stop bit 1
P01	=	Is in position 1	P2A	=	Position 2A reached	V2	=	Speed bit 2
P02	=	Is in position 2	P2E	=	Position 2E reached	V1	=	Speed bit 1
P0E	=	Position reached	P1A	=	Position 1A reached	DRI	=	Direction of rotation
DZE	=	Speed reached	P1E	=	Position 1E reached	RES	=	Software reset
STP	=	Motor at standstill	NPA	=	Go to reference point			

14 Audible Signals

14.1 Audible Error Signals

Note
Whenever an error signal is issued, the drive is made to stop. The signal can be heard until the drive is turned off.

ERROR 1: Position transmitter error
(1 short, 1 long signal)

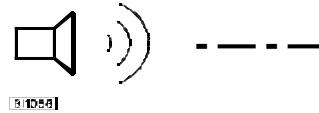

- Position transmitter defective or not connected
- Position transmitter not mounted on the sewing machine shaft

ERROR 2: Mains interruption
(2 short, 1 long signal)

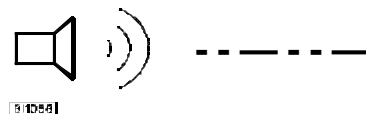

- Brief interruption of the mains supply (up to approx. 2 sec.)
- Loading relay is not switched

ERROR 3: Blocking control
(3 short, 1 long signal)

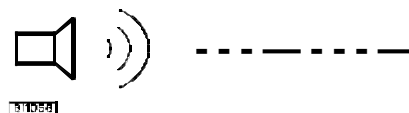

- Sewing machine shaft does not move despite motor activation
- Set speed is not reached

ERROR 4: Processor breakdown (illegal opcode)
(4 short, 1 long signal)



- Microprocessor does not work properly
 - Interferences from outside (e. g. sewing machine head not grounded, line voltage disturbed)
 - Hardware malfunction on the computer printed circuit board

ERROR 5: Commutation transmitter error
(5 short, 1 long signal)

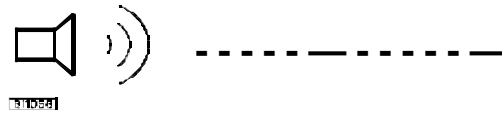

- Commutation transmitter defective

14.2 Audible Signal of the Module Address

If the pedal is not in position zero (neutral), when switching the power on, the module address is issued. The leading hexadecimal digit “F” is suppressed. At the preset address “F0”, only a long beep is issued after a long pause. At all other addresses, the second hexadecimal digit determines the number of short beeps, e. g. “F3”: **3 short beeps, pause, long beep, long pause**. The phases of the error signals are considerably shorter.

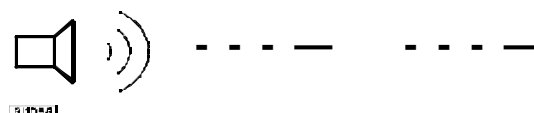

15 Examples of Connections



ATTENTION!
Use shielded cables only.

15.1 Reset with External 24V Supply

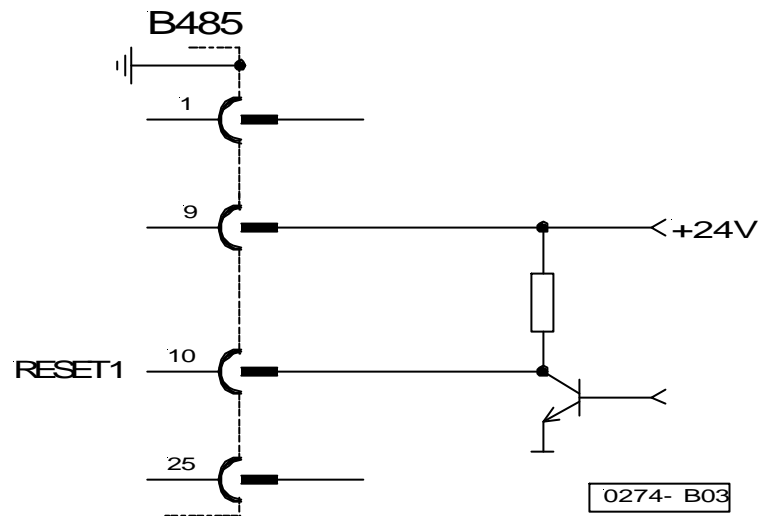

15.2 Reset with Optocoupler

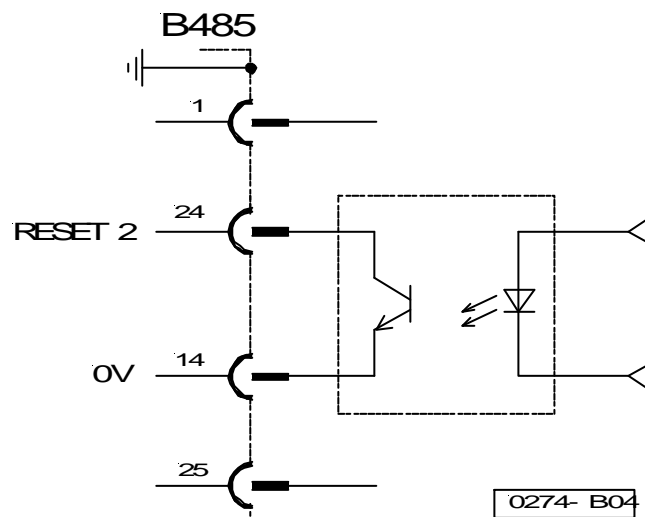

15.3 Bus-Capable Signals IRQ1 and IRQ2

(See also software agreements in chapter "Parameters"!)

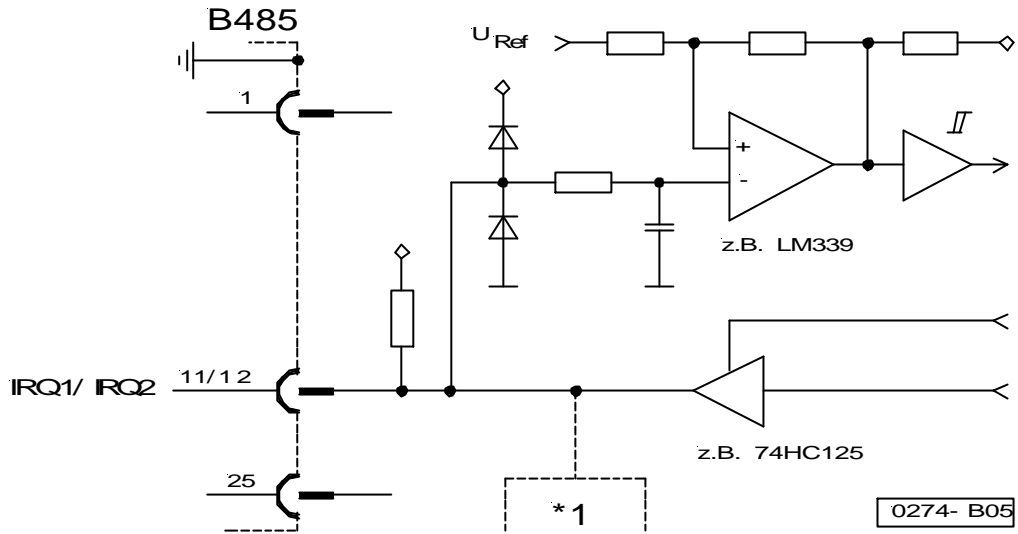

15.4 Signals U/D, SYN and G1

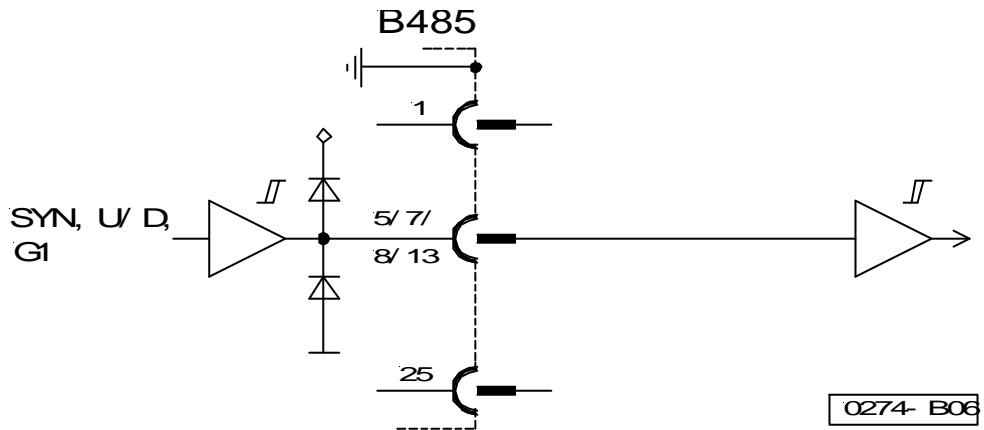

15.5 Bus-Capable Signals POS1 and FEHLER [ERROR]

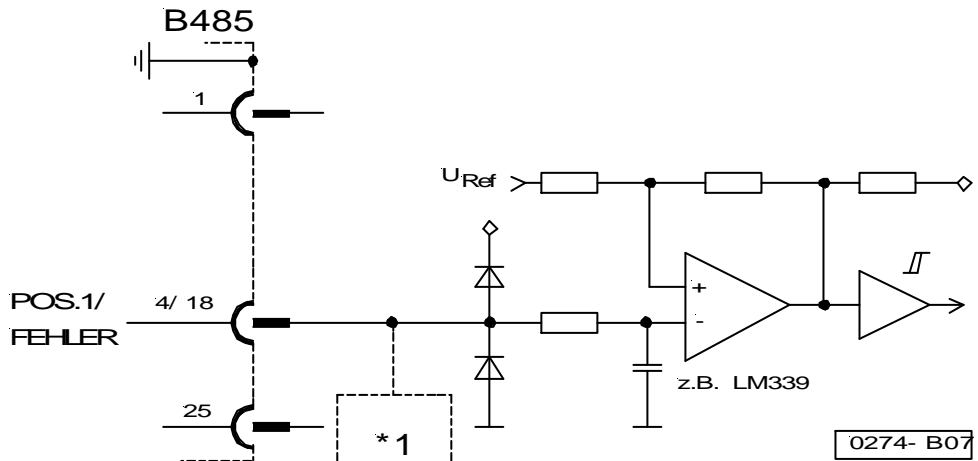

*1 = Further modules can be connected here!

15.6 Differential Signal Link

- G1 = Generator 512 impulses / rotation
- POS2 = Position 2
- U/D = Clockwise / counterclockwise rotation

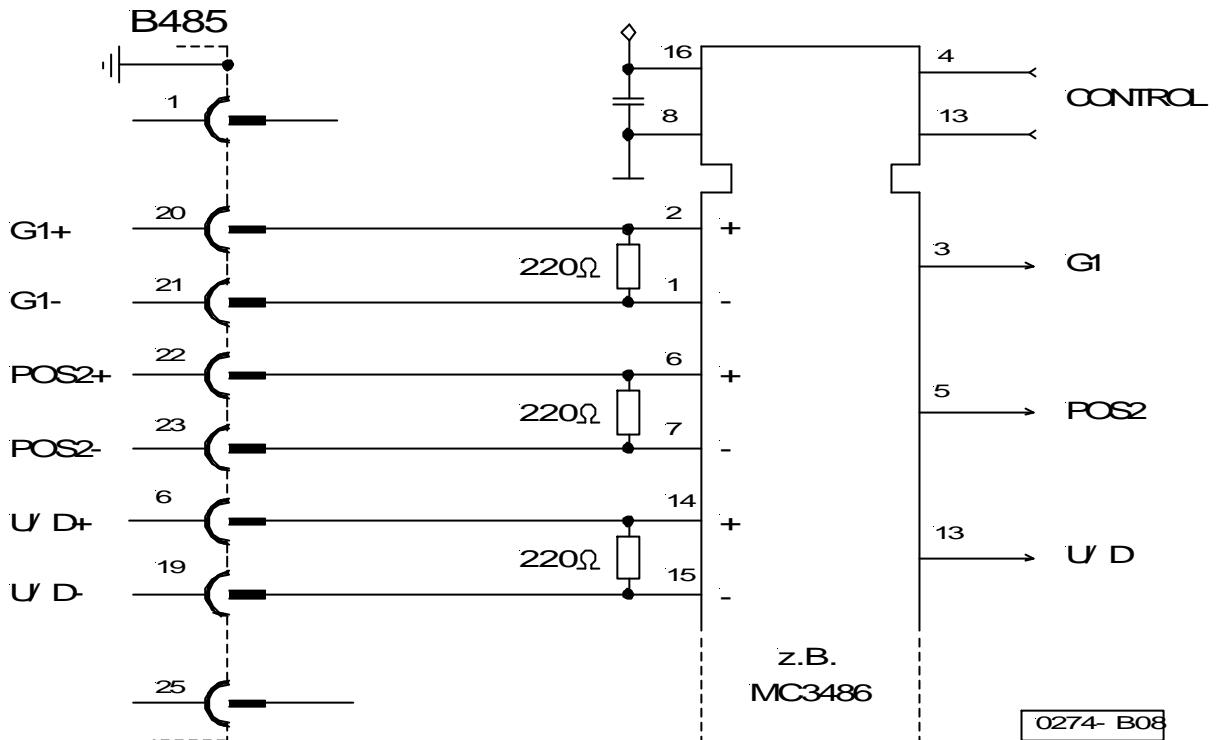

15.7 RS485 Data Transfer with One Drive

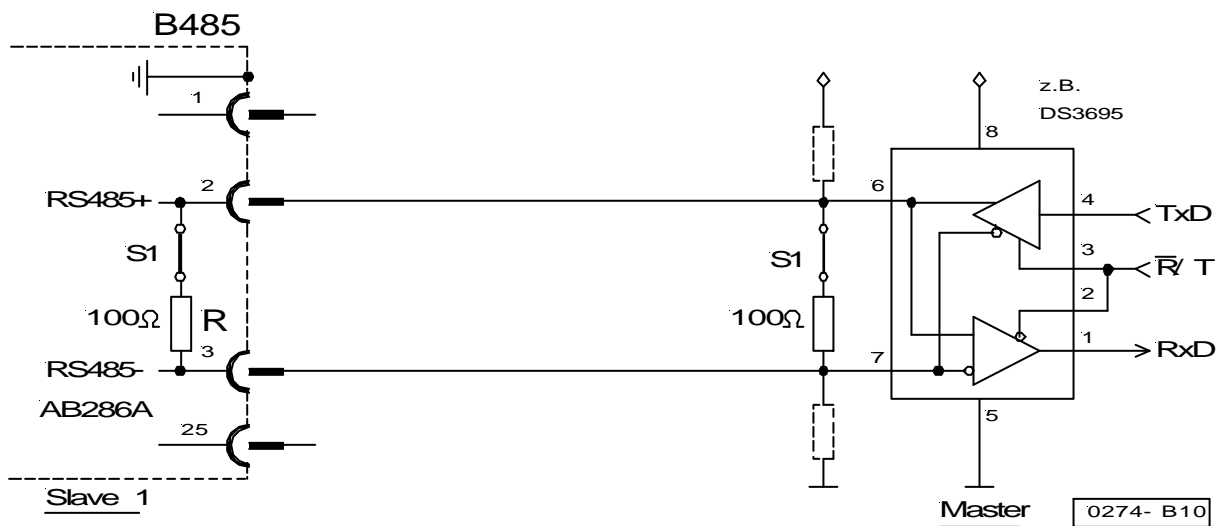

15.8 RS485 Data Transfer with Several Drives

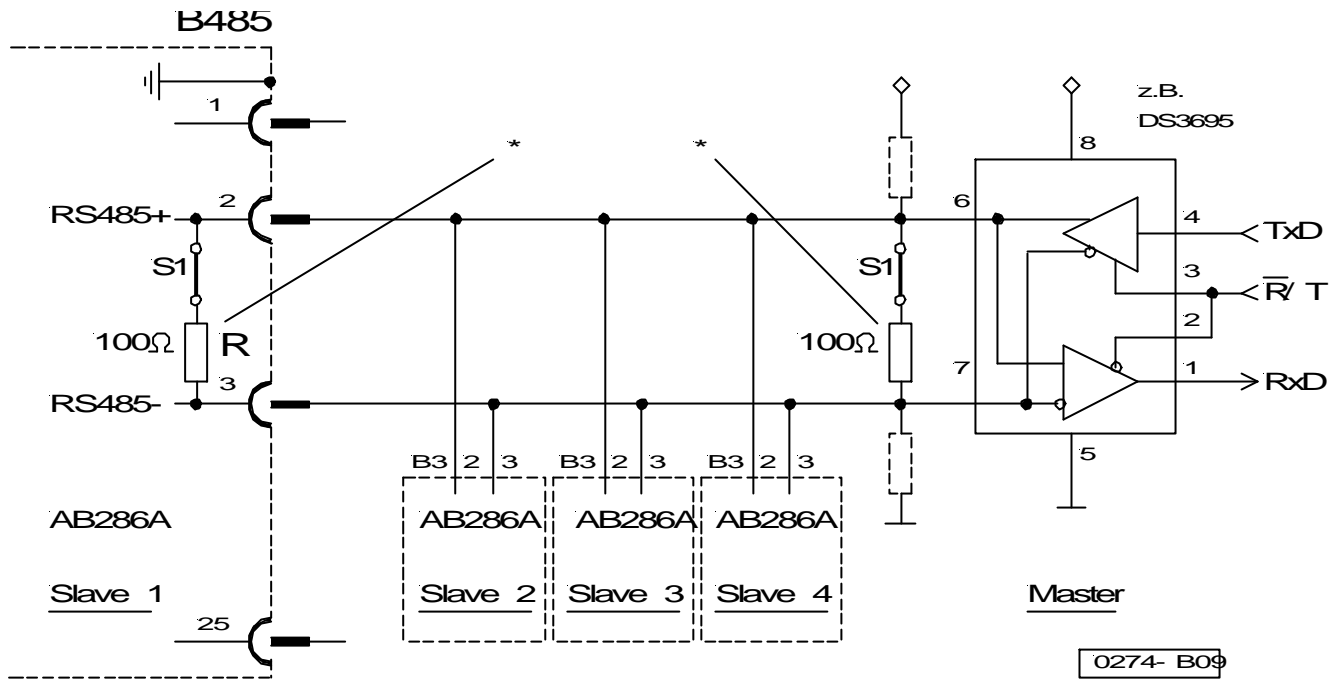

* = Jumper S1 for terminating resistors

Deactivate terminating resistors “R” in AB286A control on “slave 2, 3, 4” by means of a jumper! Determine different addresses (max. 16) if several drives are connected.

15.9 Activate / Deactivate Terminating Resistor

- Disconnect mains
- Remove rear (component side) control cover after loosening the 4 screws
- Close jumper S1 (see figure in chapter “Socket Connectors”) on small p.c.b. = terminating resistor is effective
- Open jumper S1 on small p.c.b. = terminating resistor is not effective
- Put cover on again and tighten the screws



ATTENTION!
Before removing the cover, turn power off and remove mains plug from outlet!

Parameter 56 = 01 Sensor active low (edge) Signal on B18/7

* = Reference point
 2E = 0
 2A = 10
 2A' = 20

Motor 1:1

Handwheel +180°

ccw rotation (positive counting direction)

cw rotation (positive counting direction)

1')

PARAM. 0A = xxxxxx0x
 PARAM. 04 = xxxxxx0x

0274-B28

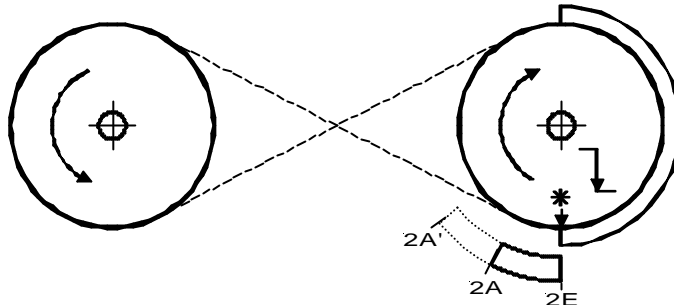

cw rotation (negative counting direction)

cw rotation (positive counting direction)

4')

PARAM. 0A = xxxxxx1x
 PARAM. 04 = xxxxxx1x

0274-B29

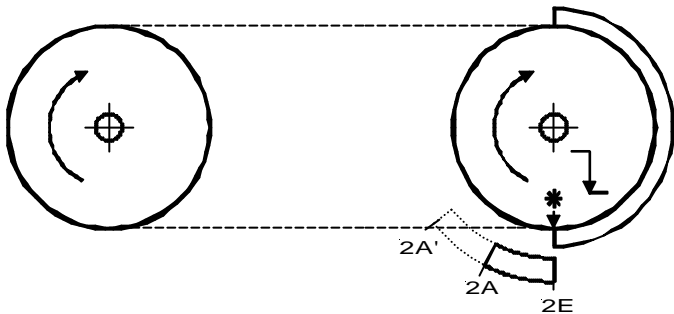

The type of synchronization signal for generating the positions can be determined by parameter 56:

Parameter 56 = 0 The reference point is generated by the transmitter in the motor.

Parameter 56 = 1 The reference point is the falling edge of the external sensor with positive counting direction.

Parameter 56 = 2 The reference point is the increasing edge of the external sensor with positive counting direction.

The direction of rotation which can only be measured on the motor is used as counting direction for the motor shaft and the handwheel shaft. If control bit CNTD = 0 (parameter 0A bit 1), the counting direction of the motor and the handwheel is the same. If control bit CNTD = 1, the counting direction of the motor and the handwheel is not the same.

The examples are based on the condition that the signal disk of the sensor is fixed on the handwheel.

If the falling edge (examples 1 and 2) is selected as synchronization signal, the reference point remains the same for both directions of rotation. With control bit CNTD it is possible to set the reference point to the same spot on the handwheel if the motor is mounted in the opposite direction, i.e. motor and handwheel rotate in different directions (examples 3 and 4).



FRANKL & KIRCHNER GMBH & CO KG
SCHEFFELSTRASSE 73 – D-68723 SCHWETZINGEN
TEL.: (06202)2020 – TELEFAX: (06202)202115
email: info@efka.net – <http://www.efka.net>



OF AMERICA INC.
3715 NORTHCREST ROAD – SUITE 10 – ATLANTA – GEORGIA 30340
PHONE: (770)457-7006 – TELEFAX: (770)458-3899 – email: efkaus@aol.com



ELECTRONIC MOTORS SINGAPORE PTE. LTD.
67, AYER RAJAH CRESCENT 05-03 – SINGAPORE 139950
PHONE: 7772459 – TELEFAX: 7771048 – email: efkaems@cyberway.com.sg