

JUKI®

COMPUTER SEWING MACHINE

HZL-T100

SERVICE MANUAL

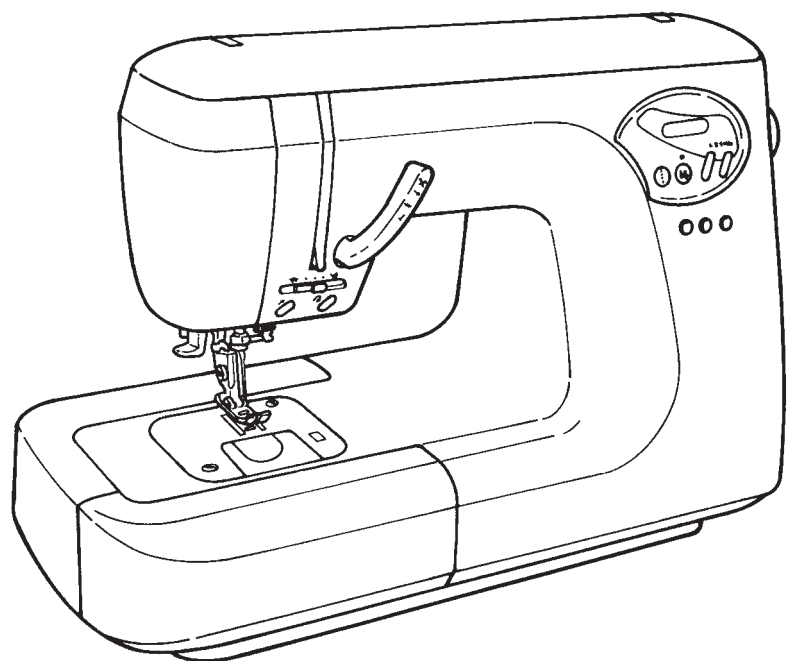

CONTENTS

[1] SPECIFICATIONS	1
[2] CONFIGURATION	4
[3] ASSEMBLY / DIASSEMBLY	5

Frame components

1. Top cover, top board	5
2. Handle, face plate cover	5
3. Operating lever	5
4. Front panel	6
5. Bed base, cylinder bed lower cover	6

Functional components

1. Microcomputer circuit board, main shaft detecting	7
2. Motor, control box	7
3. Idler, bobbin winder base (asm.)	8
4. Transformer, power switch	8
5. Needle bar connecting rod, needle throwing STM ..	9
6. Face plate (asm.)	9
7. Main shaft, operating lever receiving plate	10
8. Cylinder bed receiving plate (asm.)	10
9. Needle bar frame stud (asm.)	11

[4] CIRCUIT BOARD CONNECTING DIAGRAM	12
---	-----------

[5] ADJUSTMENT	13
-----------------------------	-----------

Sewing components

1. Height of needle bar	13
2. Needle entry (lateral) in the throat plate (needle plate)	13
3. Height of the presser foot	13
4. Height of the feed dog	14
5. Adjusting the needle to hook timing	14
6. Clearance between the needle and the blade point	15
7. Position of the detent plate of the inner hook (position of the bobbin case opening lever)	15
8. Adjusting the longitudinal feed	16
9. Buttonhole change-over switch	17
10. Vertical position of automatic threader hook	17
11. Adjusting the tension	18-21

Automatic thread trimmer components

1. Position of the thread trimming switch and one-stitch switch	22
2. Timing of thread trimming	22
3. Position of the moving knife (draw-in position of the moving knife)	23
4. Adjustment of the knife driving link	23
(Clearance between the driving link roller and the thread trimming cam)	
5. Adjustment of the knife disengaging plate	24
(Engagement of the disengaging plate and the thread trimming cam)	
6. Looper stroke (vertical stroke)	24
7. Adjusting the position of knife	25
8. Stop position of thread trimmer	25



WARNING :

To avoid the risk of fire, electric shock, injury to persons or damage to components, especially keep the following:

- When disassembling, assembling or adjusting the sewing machine, remove the power plug.
- When assembling, be careful about the electrical cord being caught with other components, damage to the covered parts of the cord or miswiring.
- When replacing the part(s), use the genuine part(s).

[1] SPECIFICATIONS

(1) Speed regulating components

Slide control system		
Stepless speed change gear	For straight stitching	: 116 to 750 rpm
	For stitching methods other than straight stitching	: 116 to 500 rpm
	For winding a bobbin	: 116 to 700 rpm

When using this controller, the slide control mechanism is inoperative.
The control speed is same as the speed controlled by the slide control mechanism.

(2) Table stand components

Main unit case	: The main unit case covers the components exclude the under cover and the handle.
Handle	: Designed to be tilted from the main unit of the sewing machine.

(3) Bed type

Cylinder bed and flat bed
Quickly change over by a finger control

(4) General mechanism

1. Thread take-up : Link type thread take-up with slit for one-touch utility thread eyelet
2. Hook : Full-rotary, vertical-axis hook
3. Pressure regulator : Constant pressure applying system
4. Lighting mechanism : Built in face plate cover
The power switch of the sewing machine is commonly used as the lamp switch.
5. Needle thread stand : Horizontal type thread stand built in the top board
6. Bobbin thread winder : Bobbin winder shaft sliding method
The bobbin winder starts winding a bobbin by operating the start/stop switch.
7. Needle threader : One-touch
8. Presser foot : Exclusive transparent presser foot
9. Replacement of presser foot : Snap-on/-off type
10. Power switch : 2-step power switch commonly used as the lamp switch
11. Lubrication : No lubrication is required (under the normal operating conditions).
* Lubricating the inner hook is prohibited.
12. Cable : A 1.9 m long power cable is removable.

(5) Needle bar rocking mechanism

1. Needle bar rocking method : By the arc method
2. Straight stitching : Left, center, right
3. Stitch width : Max. 6 mm depending on the stitch pattern
4. Adjustment of stitch width : By sliding the lever (The stitch width adjusting mechanism is effective when the manual operation indication LED lights up.)
When manually adjusting, notice of change-over of the set value is given by the buzzer sound.*
As for the part of automatic set value, the notice is given by the flash on/off of LED.*
5. Standard line : Left standard line
6. Needle bar driving system : By a stepping motor

(6) Feed mechanism

1. Feed amount : 0 to 4 mm
2. Reverse feed amount : 0 to 2.4 mm
3. Adjustment of feed amount : By sliding the lever (The feed amount adjusting mechanism is effective when the manual operation indication LED lights up.)
When manually adjusting, notice of change-over of the set value is given by the buzzer sound.*
As for the part of automatic set value, the notice is given by the flash on/off of LED.*
4. Reverse feed stitch : The machine performs reverse feed stitching at low speed only when the switch is ON.
5. Feed mechanism : By a stepping motor

(7) Special-purpose mechanism

1. Automatic thread trimmer The moving knife trims the thread while the main shaft makes a revolution (or a shaft revolution from its lower stop position) by setting the operation lever to the thread trimming position. (116 rpm)
2. Automatic needle threading device The hook automatically rotates and returns to its home position by lowering the threading lever.
3. Automatic buttonholing Auto-return type full automatic buttonholing
Buttonhole size can be specified as desired. When the buttonhole is finished, the machine automatically stops after performing fastening stitching. (The machine gives an error message on the LCD to prevent the operator from starting the machine without setting the machine for the buttonholing.)
4. Selection of stitch patterns Straight stitch Direct selection by the touch switch *
Other stitch patterns by shift selection (99 stitch patterns)*
Shift direction change-over switch is provided. *

5. Number of stitch patterns	Continuous stitch patterns 43*, One point stitch patterns 57* Total 100 stitch patterns Buttonhole : Buttonhole(small), Buttonhole(large), Eyelet buttonhole *, Decorative buttonhole
6. Slow start function	Approx. 1 stitch is sewn at the speed of 116 rpm after the start switch is turned ON.
7. Constant stop position of the needle bar	Needle bar can be stopped in its highest position or lowest position by using the synchronizer shielding plate and photo-interrupter. · Needle bar stops in its lowest position at the time of the end of sewing. · Needle bar stops in its highest position when the stitch pattern is selected while it stops in its lowest position. · Needle bar stops in its highest position at the time of thread trimming, bobbin winding or lifting the presser foot.
8. Prevention of incorrect needle insertion	A needle can be attached on the machine only when installing direction of the needle is correct.
9. Prevention of overheat	If the sewing machine rotation is locked for two seconds, the power to the motor is automatically turned OFF. When the temperature of the motor abnormally rise, the power to the motor is turned OFF. (Thermal cut) After the temperature of the motor has sufficiently lowered, the machine can be started.
10. Bobbin case	Integral with the inner hook
11. Presser foot storage box	Presser feet supplied as standard accessories of the machine are stored in the auxiliary bed of the main unit of the sewing machine.
12. Automatic lock stitch	When the lock stitch is set, 3-stitches of the lock stitch are automatically performed at sewing -start & -end. In case of the one-point stitch pattern, the lock stitch switch is automatically turned ON. *
13. Thread tension unit:	Pre-tension, Disc pressure type thread tension with 2nd tension.
14. Memory:	Memory capacity 20 pcs. Every time the clear key is pressed, the stitch patterns set are cleared from the last one. * When keeping pressing the clear key, all the stitch patterns set are cleared.

(8) Dimensions and weight

Dimensions	400 mm (width) x 175 mm (depth) x 280 mm (height)
Weight	8.5 kg

(9) Electric rating

Entire unit of the sewing machine	220-240 V, 85 W, 50 Hz
Lamp	(12 V, 5 W)

[2] CONFIGURATION

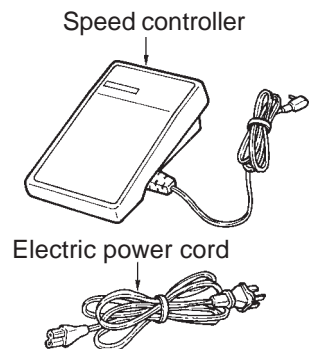
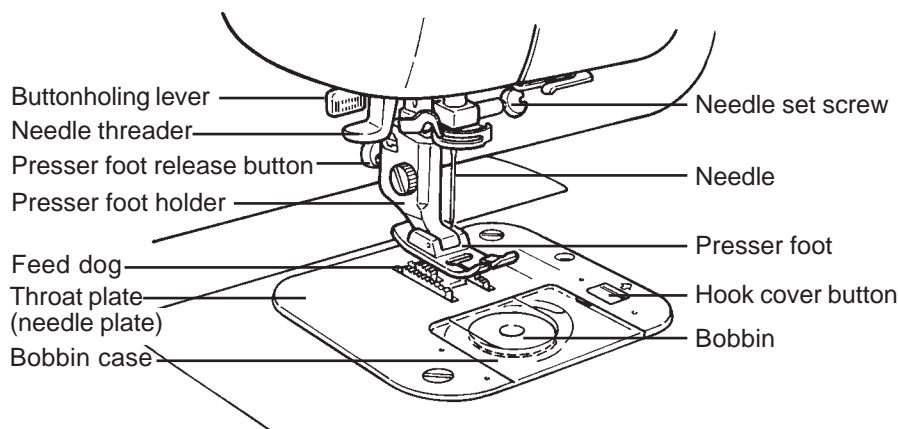
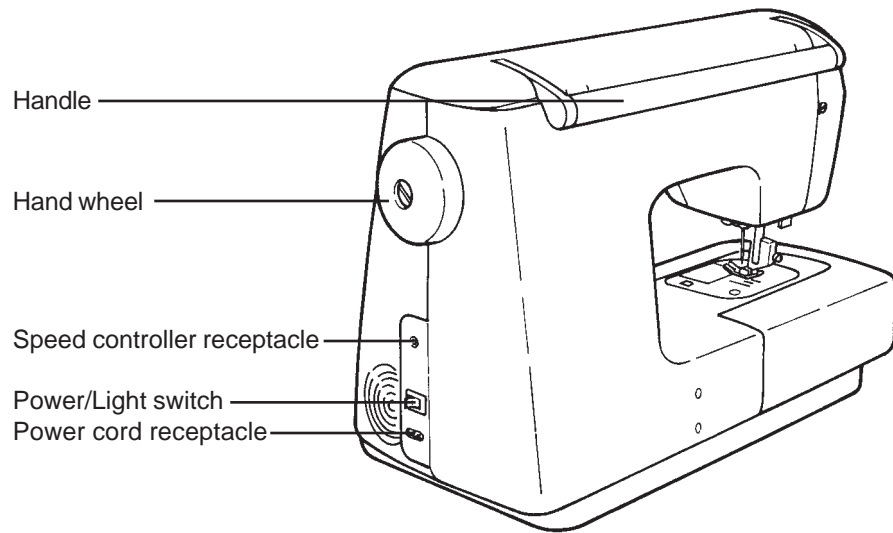
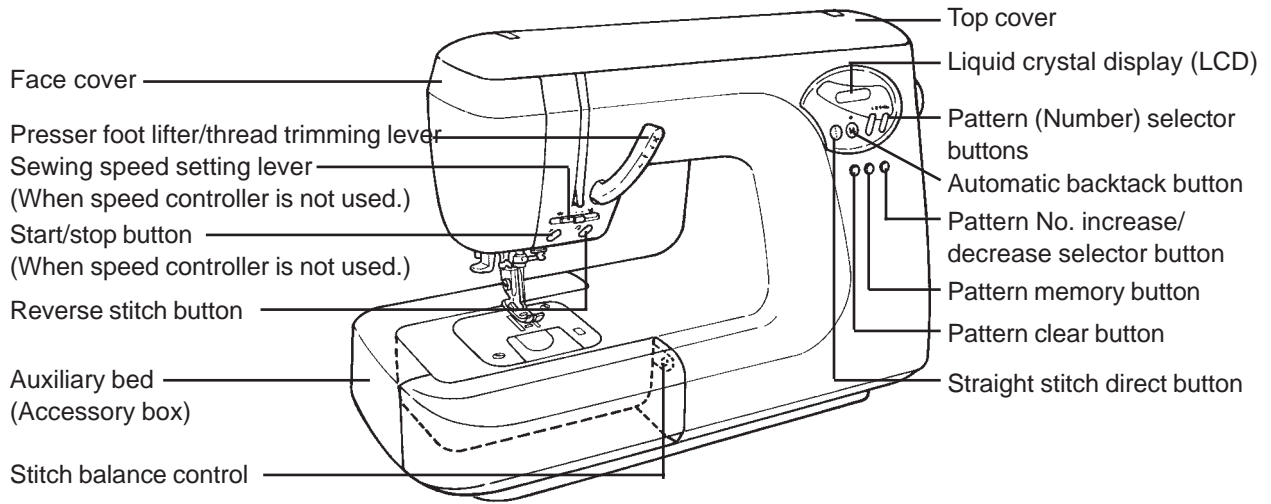
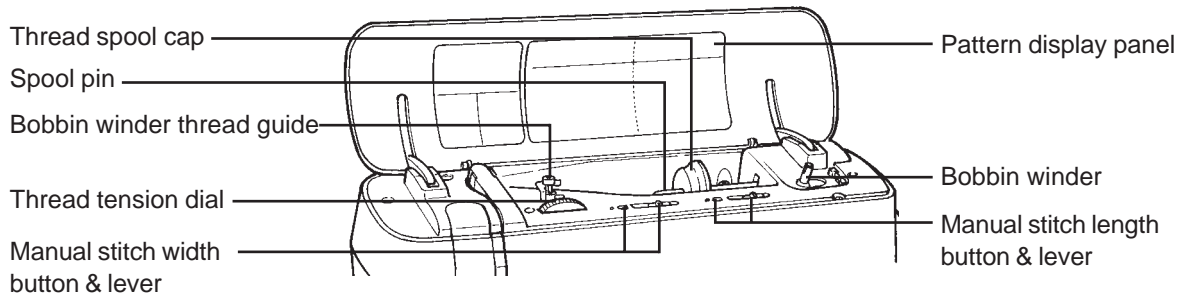

[3] ASSEMBLY / DISASSEMBLY

Frame components

1. Top cover, top board

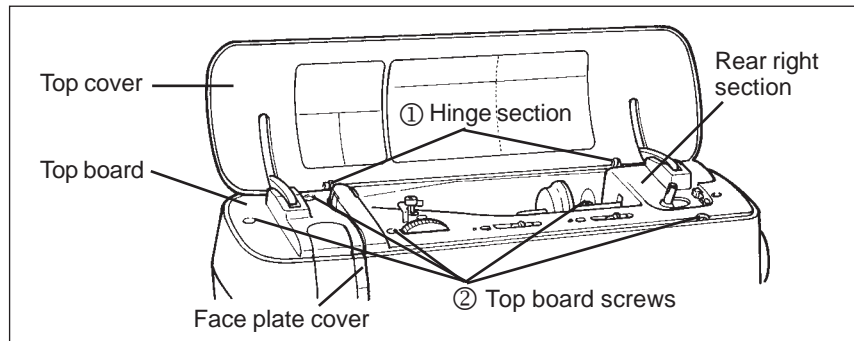

Disassembly	Assembly	Point to be checked
<p>When removing the top cover, bend hinge ①. (The top board can be removed with the arm cover attached.)</p> <p>Remove five screws ② in the top board. Lifting the top board, draw out the connector.</p> <p>* Do not remove the screw in the bobbin thread winding amount adjusting plate.</p>	<ul style="list-style-type: none"> Set the top cover in place with closed. Set the top board on the frame. Set the top board with its rear right section accurately fitted with the face plate cover. 	<ul style="list-style-type: none"> The hinge easily bend when closing the top cover. Be careful to connect the connector without fail. Take care not to allow the top board to become loose.

2. Handle, face plate cover

Preparation required
 ○ Remove the top board.

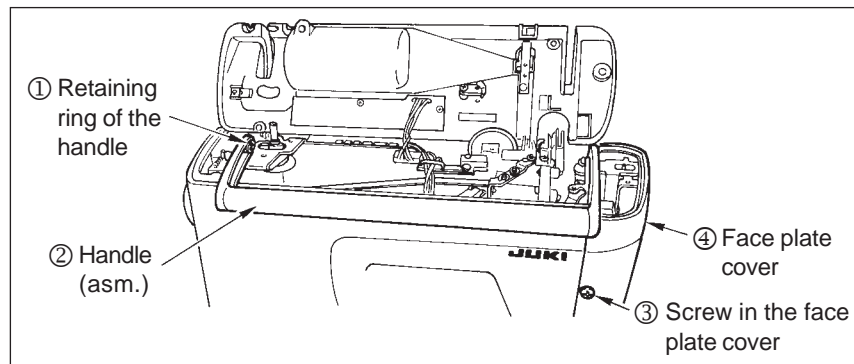

Disassembly	Assembly	Point to be checked
<p>Remove one retaining ring ① of the handle.</p> <p>Remove handle ②.</p> <p>Loosen screw ③ in the face plate cover, and remove the cover.</p>	<ul style="list-style-type: none"> Set the handle on the frame. Attach the retaining ring to the handle. Set the cover on the frame, and tighten the screw. 	<ul style="list-style-type: none"> Carefully check the installing direction of the handle. Securely attach the two installing bosses in the face plate.

3. Operating lever

Preparation required
 ○ Remove the top board.

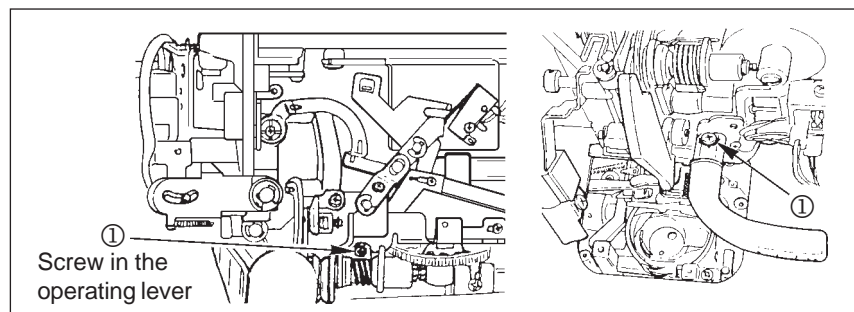

Disassembly	Assembly	Point to be checked
<p>Loosen screw ① in the operating lever, and draw out the operating lever.</p>	<ul style="list-style-type: none"> Set the lever in place, and tighten the screw. 	<ul style="list-style-type: none"> Take care not to allow the screw to become loose while the sewing machine is in operation.

4. Front panel

Preparation required

- Remove the top board.
- Remove the front cover.
- Remove the operating lever.

[Top surface of the frame]

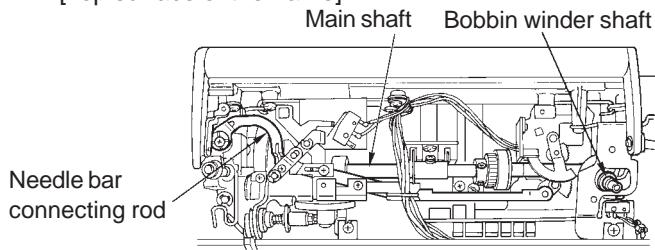

[Side face of frame (face frame)]

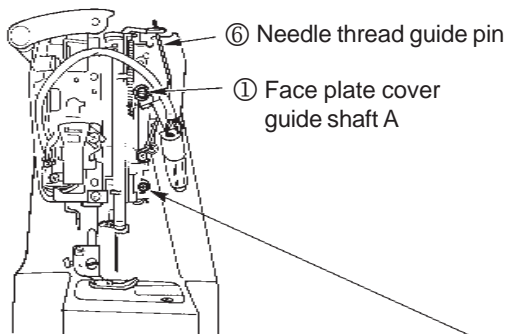

③ Center screw of panel Engaging section at the center of panel

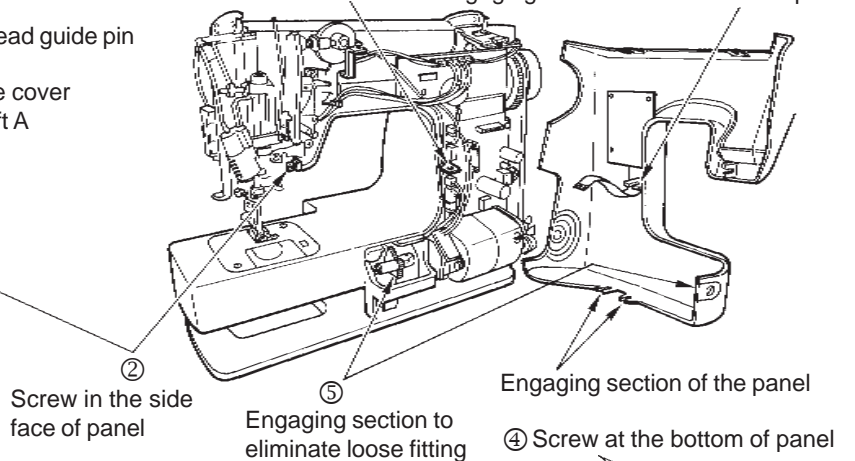

[Bottom view of frame]

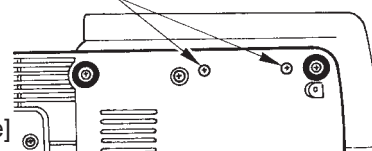

Disassembly	Assembly	Point to be checked
Loosen screw ② in the face plate of the panel. (You may loosen ① and tilt the lamp instead of loosening screw ②.) Loosen screw ③ at the center of panel. Loosen two screws ④ in the bottom of panel. · In order to release the engaging section ⑤ to eliminate loose fitting, remove the panel while lifting it.	Assemble ② through ⑤ without fail. · Tighten the four screws which have been loosened. Caution: Make sure that the indicator connecting cable has been connected.	Fit needle thread guide pin ⑥ in the groove on the front panel in the correct manner.

5. Bed base, cylinder bed lower cover

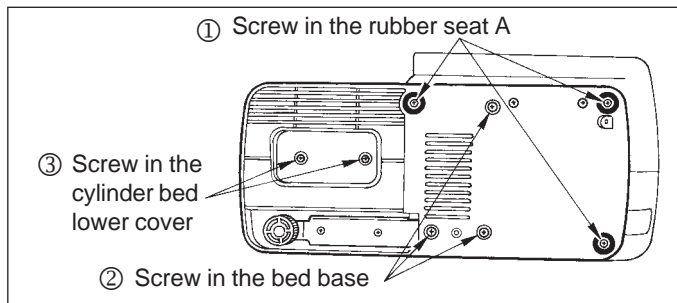

Disassembly	Assembly	Point to be checked
Remove three screws ① in the rubber seat A. Remove three screws ② in the bed base. Remove two screws in cylinder bed lower cover ③, and remove the cover.	· Attach the bed base on the frame. · Fix the bed base by tightening the screw which have been removed.	· Set the three rubber seat A on the bed base with accuracy.

Functional components

1. Microcomputer circuit board, main shaft detecting

Preparation required

- Remove the top board.
- Remove the face plate cover .
- Remove the front panel.

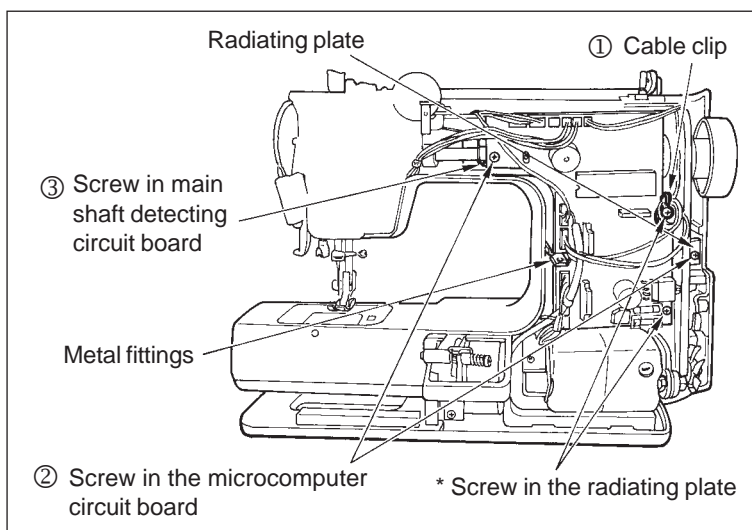

Disassembly	Assembly	Point to be checked
<ul style="list-style-type: none"> · Remove connectors (14 connectors). Cut cable clip ①, and remove the lead from the radiating plate. Remove two screws ② in the microcomputer circuit board. (Do not remove the screw in the radiating plate attached by an asterisk (*).) Remove one screw ③ in the main shaft detecting plate circuit board, and remove the circuit board. 	<ul style="list-style-type: none"> · Attach the microcomputer circuit board on the frame, and fix it by tightening the two screws. · Connect the connectors. (See page 12.) · Attach the main shaft detecting plate printed circuit board in place, and fix it using the screw. 	<p>Caution:</p> <p>Removing/attaching the microcomputer circuit board.</p> <p>Be sure to carefully remove the microcomputer circuit board taking care not to prevent the printed circuit board from coming in contact with the metal fittings marked with a double circuit and not to allow the radiating plate marked with a double circle to come in contact with the motor belt, transformer and other components.</p> <ul style="list-style-type: none"> · The shielding plate of the main shaft should not come in contact with the sensor when installing the printed circuit board in place.

2. Motor, control box

Preparation required

- Remove the top board.
- Remove the face plate cover.
- Remove the front panel.

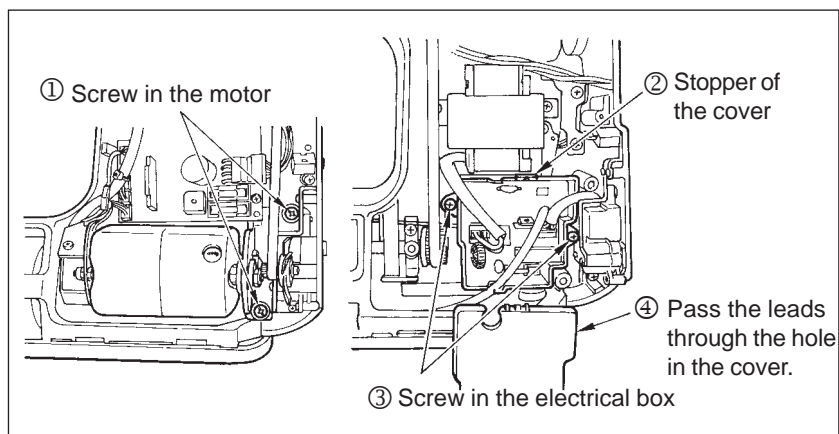

Disassembly	Assembly	Point to be checked
<ul style="list-style-type: none"> Remove two screws ① in the motor. Lift stopper ② in the cover, and remove the cover. · Remove the motor belt and the connector, then remove the motor. Remove screws ③ in the electrical box. 	<ul style="list-style-type: none"> · Attach the electrical box in place, and fix it with the screws. · Set the leads in place. (See page 12.) · Fit the cover to the electrical box. (Pass leads ④ through the hole in the cover.) · Attach the motor in place. 	<ul style="list-style-type: none"> · Fit the leads of the motor in the indented section of the cover. · Take care of the belt tension.

3. Idler, bobbin winder base (asm.)

Preparation required

- Remove the top board and the handle.
- Remove the face plate cover.
- Remove the front panel.
- Remove the microcomputer circuit board.

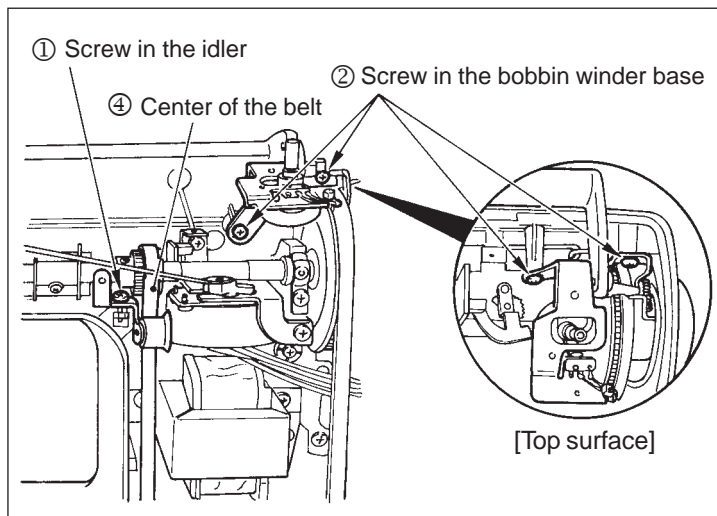

Disassembly	Assembly	Point to be checked
Loosen screw ① in the idler, then pull the idler (asm.) toward you. Remove two screws ② in the bobbin winder base, and remove the base. * Set the bobbin winder to its operating state (by setting the shaft to its right side).	<ul style="list-style-type: none"> • Check the timing of thread trimming, then attach the idler (asm.). • Attach the bobbin winder base in place, and fix it with the screws. 	<ul style="list-style-type: none"> • Refer to No. 2 on page 12 for the correct timing of thread trimming. • Belt tension: The belt should slacken by 4 to 6 mm when applying a 200g load to center ④ of the belt. • When winding a bobbin, the bobbin winding switch should be turned OFF.

4. Transformer, power switch

Preparation required

- Remove the top board and the front face cover.
- Remove the front panel.
- Remove the microcomputer circuit board.
- Remove the idler and the motor. (Remove the timing belt.)
- Remove the cover of the electrical box.

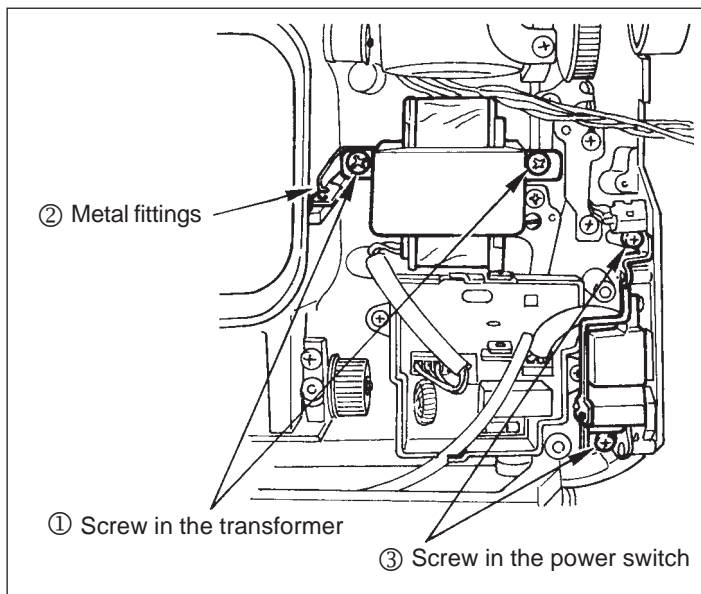

Disassembly	Assembly	Point to be checked
Remove two screws ① in the transformer. (Metal fittings ② come off simultaneously with the screws.) • Remove the connector from the printed circuit board. Remove two screws ③ in the power switch. • Remove the connector from the printed circuit board.	<ul style="list-style-type: none"> • Attach the transformer to the frame, and fix it with the screws. • Attach the power switch to the frame, and fix it with the screws. 	<ul style="list-style-type: none"> • Refer to page 12 for how to connect the connector. • Take care of the polarity of the connector.

5. Needle bar connecting rod, needle throwing STM

Preparation required

- Remove the top board.
- Remove the face plate cover.
- Remove the front panel.
- Remove the microcomputer circuit board.

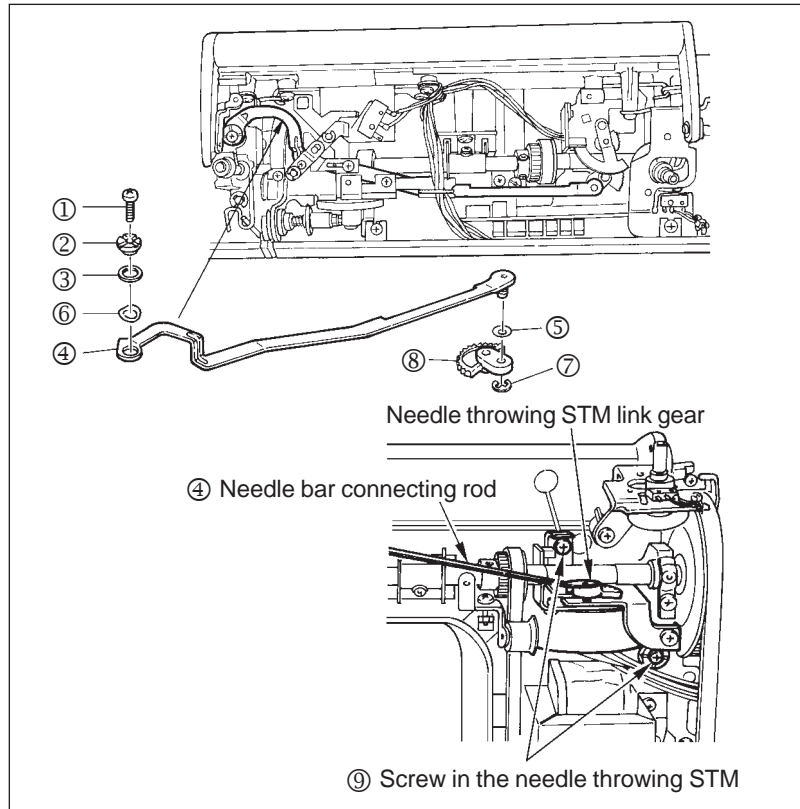

Disassembly	Assembly	Point to be checked
<p>Remove screw ① in the needle entry adjusting collar, and remove components ②, ③ and ⑥.</p> <p>Remove E ring ⑦ of the needle bar connecting rod shaft.</p> <p>Then remove washer ⑤ and needle bar connecting rod ④.</p> <p>Remove two screws ⑨ in the needle throwing STM, then remove STM (stepping motor).</p>	<ul style="list-style-type: none"> • Fix the needle throwing STM with the screws. • Check the performance of the needle throwing STM and the needle bar frame. • Attach the connecting rod in place. • Attach the components which have been removed in place. 	<ul style="list-style-type: none"> • Do not bend the connecting rod. • Be sure to attach the components properly.

6. Face plate (asm.)

Preparation required

- Remove the top board.
- Remove the face plate cover.
- Remove the front panel.

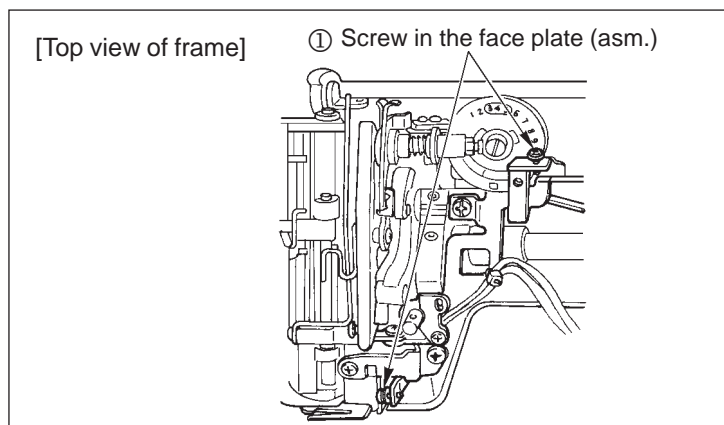

Disassembly	Assembly	Point to be checked
<p>Remove two screws ① in the face plate (asm.), then remove the face plate (asm.).</p>	<ul style="list-style-type: none"> • Attach the face plate (asm.) on the frame, and fix it with the screws. 	<ul style="list-style-type: none"> • Make sure that the front panel and the face plate cover are spaced equidistantly with respect to the lateral direction.

7. Main shaft, operating lever receiving plate

Preparation required

- Remove the top board and the face plate cover.
- Remove the front panel.
- Remove the microcomputer circuit board and the idler.
- Remove the timing belt.
- Remove the needle bar connecting rod.
- Remove the motor belt.

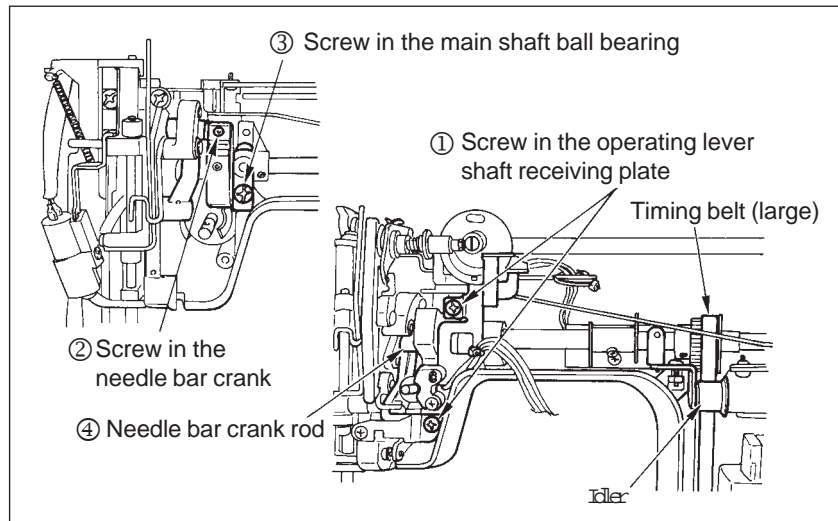

Disassembly	Assembly	Point to be checked
<p>Remove two screws ①, and remove the operating lever shaft receiving plate (asm.).</p> <p>Loosen screw ② in the needle bar crank. Remove screw ③ in the ball bearing receiving plate located at the right-hand side and remove the right-hand receiving plate. Also, remove screw ③ in the ball bearing receiving plate located at the left-hand side and remove the left-hand receiving plate.</p> <p>· Detach the right-hand end of the main shaft from the frame, and draw out needle bar crank rod ④ from the needle bar connecting stud.</p> <p>Or, remove the needle bar crank.</p>	<p>· Attach the main shaft in place. (Engage the main shaft with the needle bar crank or the crank rod.)</p> <p>· Set the operating lever shaft receiving plate in place, and fix it with the screws.</p>	<p>* Set the timing belt and the motor belt in place.</p> <p>· Check the torque and thrust play of the main shaft.</p> <p>· Check the retaining position of the leads.</p>

8. Cylinder bed receiving plate (asm.)

- Remove the top board and the bed base.
 - Remove the cylinder bed lower cover.
 - Loosen the idler.
- (See No.3 on page 8)

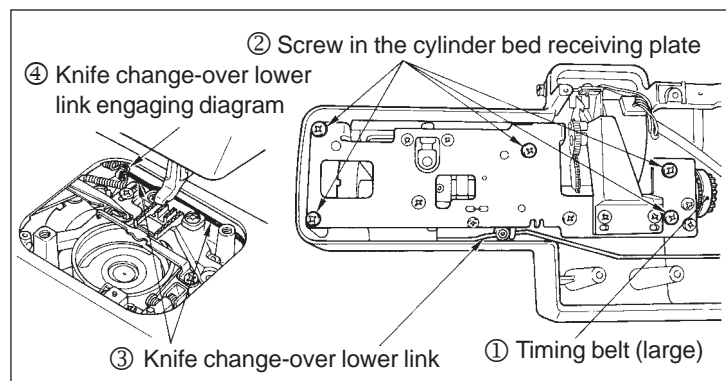

Disassembly	Assembly	Point to be checked
<p>Remove timing belt (large) ① from the hook driving shaft pulley.</p> <p>Remove five screws in receiving plate ②.</p> <p>· Remove the receiving plate of the cylinder bed.</p> <p>Remove knife change-over lower link ③ from engaging section ④.</p>	<p>· Engage the knife change-over lower link with the receiving plate, and fix them with the five screws.</p> <p>· Put the timing belt (large) in place. Check the needle entry and the clearance provided between the needle and the blade point of the hook.</p>	<p>· A uniform clearance should be provided between the frame and the throat plate (needle plate).</p> <p>· Check the torque of the hook driving shaft.</p> <p>· When putting the timing belt in place, refer to the description indicating the timing of thread trimming (No.2 on page 22.)</p>

9. Needle bar frame stud (asm.)

Preparation required

- Remove the presser foot holder and the needle.
- Remove the top board and the face plate cover.
- Remove the front panel.
- Remove the screw (located at the upper right section) of the microcomputer circuit board.
- Remove the connectors J2, J3 and J6 through J8.
- Cut the cable clip.
- Remove the operating lever shaft receiving plate (asm.).
- Remove the joint (left) of the needle bar connecting rod.
- Loosen the screw in the needle bar crank.
- Bring the moving knife to the rightmost end of its stroke.

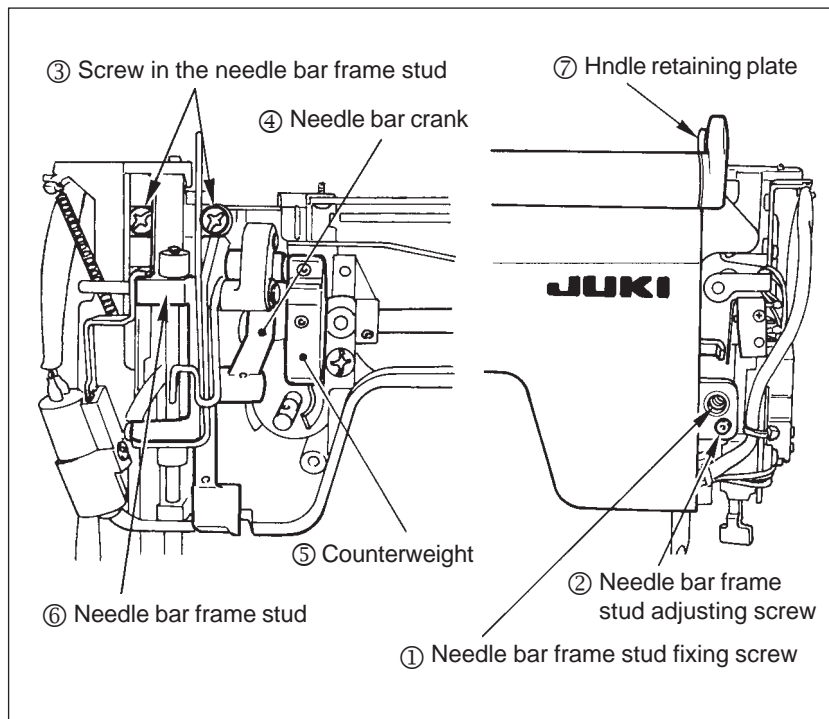

Disassembly	Assembly	Point to be checked
<p>Remove needle bar frame stud fixing screw ① .</p> <p>Loosen needle bar frame stud adjusting screw ② .</p> <p>Remove two screws in needle bar frame stud ③ .</p> <p>Draw out needle bar crank ④ from counterweight ⑤ .</p> <p>At this time, draw needle bar frame stud to the left so that it opens.</p> <ul style="list-style-type: none"> · Disconnect the knife change-cover upper link. <p>* Removing the handle and handle retaining plate ⑦ will allow you to carry out the aforementioned disassembling procedure with ease.</p>	<ul style="list-style-type: none"> · Connect the knife change-over upper link properly. · Set the needle bar crank in the counterweight. · Fit the needle bar frame stud fixing screw in place. · Tighten the two screws in the needle bar fame stud. · Attach the operating lever shaft receiving plate (asm.) in place. <p>Then adjust the needle entry with respect to the predetermined three points referring to No. 2 on page 13 and No. 6 on page 15.</p>	<ul style="list-style-type: none"> · Do not bend the connecting rod and the microcomputer circuit board. · When setting the needle bar crank on the counterweight, fix the crank by tightening the screw in the flat part of the crank. <ul style="list-style-type: none"> · Check the lateral movement of the needle bar.

[4] CIRCUIT BOARD CONNECTING DIAGRAM

[Manual circuit board]

[Indicator circuit board]

[Power circuit board for 120V]

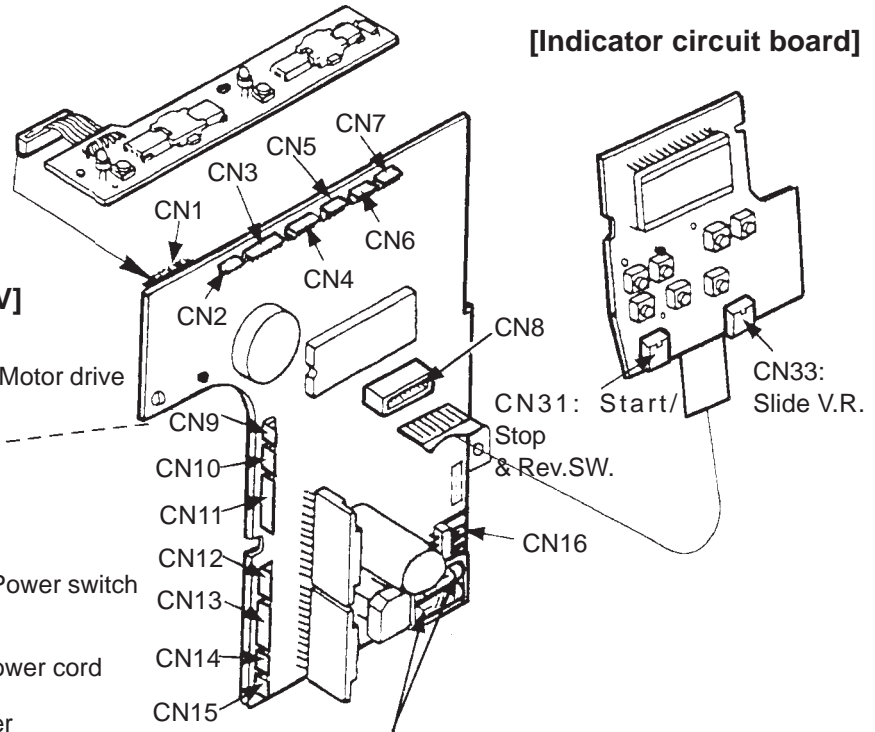
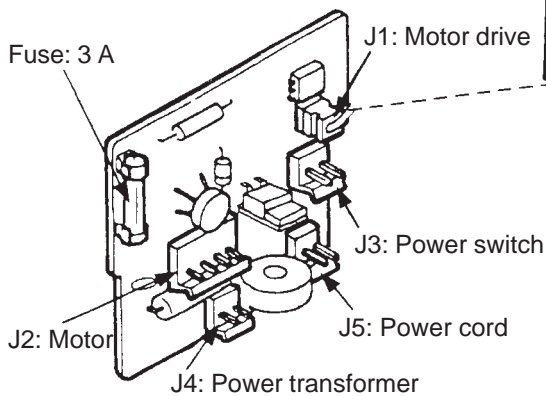

Fuse: 3 A...2 pcs m.c.c.board for 120V
 Fuse: 3.15 A...2 pcs m.c.c.board for 230V

[Power circuit board for 230V]

[Micro computer circuit board]

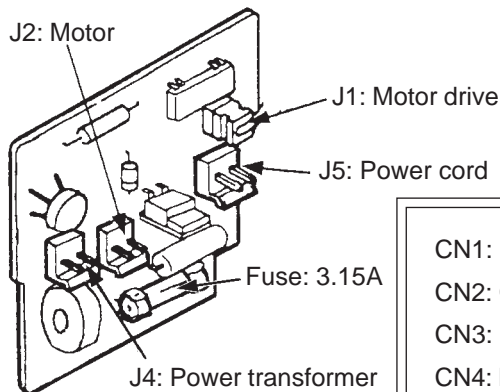

- CN1: Manual circuit board — GRA
- CN2: One stitch switch — PRP
- CN3: Main shaft detector circuit board — RED
- CN4: Button hole switch — WHT
- CN5: Lamp — WHT
- CN6: Thread trimmer switch — BLU
- CN7: Winder switch — GRA
- CN8: M. computer c. board – indicator c. board connecting wire
- CN9: Power circuit board J1 — BLK
- CN10: Needle bar rocking detector circuit board — ORN
- CN11: Needle bar rocking STM — BSTM
- CN12: Feed detector circuit board STM — WHT
- CN13: Feed STM — FSTM
- CN14: Foot controller V.R. — YEL
- CN15: Motor pulse detector circuit board — BLK
- CN16: Power transformer (11 V AC 23 V AC line)

[5] ADJUSTMENT

Sewing components

1. Height of the needle bar

- Remove the face cover, top cover and front panel.

Adjustment

- Dimension from the lower end of needle bar pin to the race face of hook : 28.72 mm
- In case needle attached incline the angle from which the needle hole is visible by 0 to 5° to the right.
(Hitched stitch prevention at the time of reverse stitch)

How to adjust

1. Make a gauge needle by cutting a household use needle to the length of 28.72 mm and attach it to the needle bar.
2. Lower the needle bar up to the lowest lead point, and slightly loosen the needle bar bushing set screw ① the extent that the needle bar does not slip down.
3. Move the needle bar up or down by hand and turn the needle bar by 10 to 5° as shown in the figure so that the cut face of the gauge needle is aligned with the race face of the hook.
4. Temporarily tighten screw ①, and after re-checking the adjustment condition, tighten further the screw.

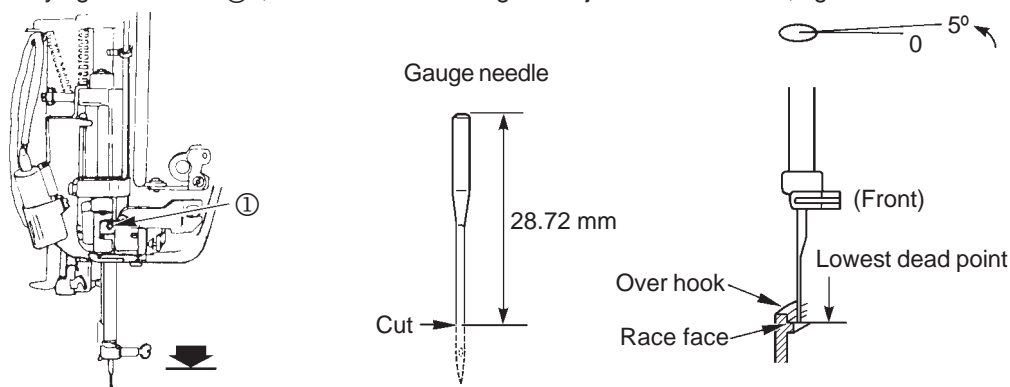

2. Needle entry (lateral) in the throat plate (needle plate)

- Remove the top board.
- Bring the needle to the straight stitching position.

How to adjust

- Loosen screw ① in the needle entry adjusting collar.
- Adjust the needle entry by turning adjusting collar ②.

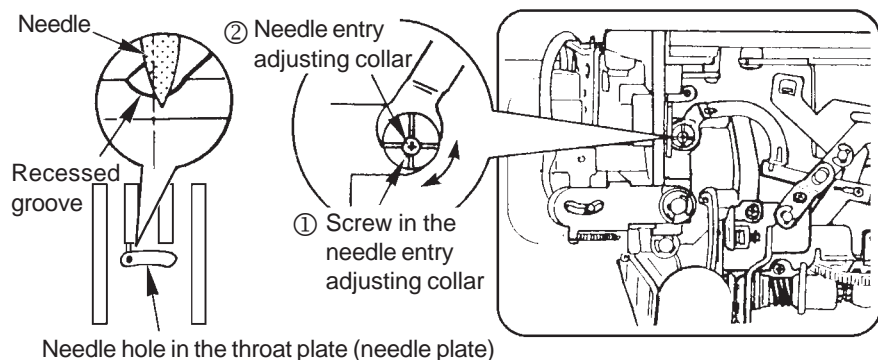

3. Height of the presser foot

- Remove the face plate cover. (Page 5)
- Left the presser foot until the sole of the presser foot is positioned 5.5 mm above the top surface of the throat plate (needle plate).

How to adjust

- Loosen presser bar position bracket, and adjust the height of presser foot.
- Adjust the orientation of presser foot so that it is in parallel with the groove in the throat plate (needle plate).

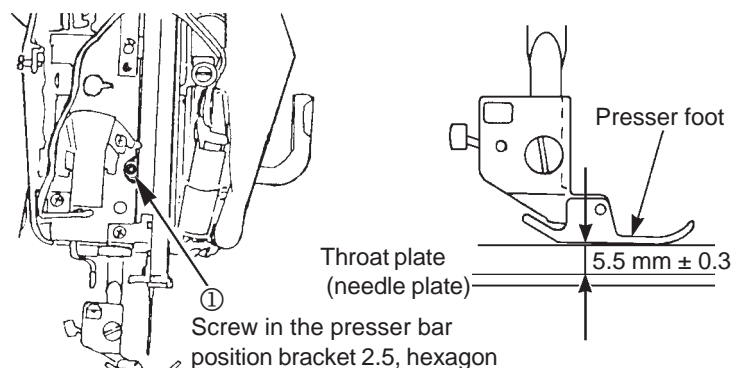

4. Height of the feed dog

○ Remove the throat plate (needle plate) to check the adjusting place.

How to adjust

1. Height of the feed dog is the height of the feed dog portion corresponding to the position of the needle hole center of the throat plate (needle plate) measured from the upper surface of the throat plate (needle plate).
2. Insert a hexagonal screwdriver into the hole for the screwdriver located in the rear side of the free arm, and loosen the hexagonal screw ① (1.5 mm).
3. Insert a small slit screwdriver from the small hole in the throat plate (needle plate), turn the adjusting screw ② and adjust so that from the upper surface of the throat plate (needle plate) to the upper end of the feed dog should become 0.9 to 1.1 mm when the feed dog is at its height point.
4. After the adjustment, tighten the screw ① .

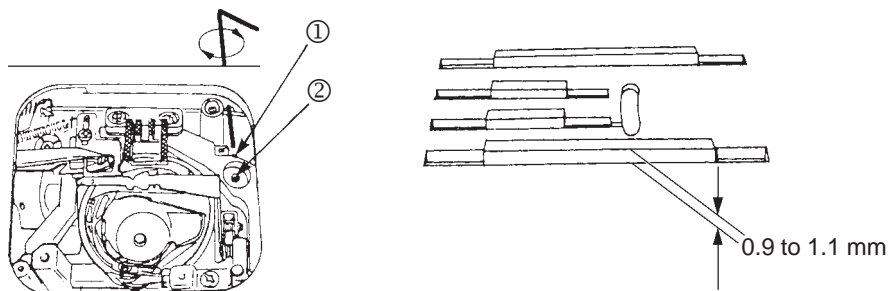

5. Adjusting the needle to hook timing

○ Remove the throat plate (needle plate), bed base, and free arm lower cover.

Checking method

1. Select the straight stitch (left position)
2. Check the needle entry point and the height of the needle bar are correct. Lowest dead point
3. Remove the throat plate (needle plate).
4. Turn the hand wheel to place the needle bar at its lowest dead point.
5. Further turn the handwheel by hand to raise the needle bar little by little, and stop the needle bar at the point B where the center of the needle is aligned with the tip of blade point of hook. At this time, check that the dimension C from the tip of the blade point of the hook to the upper end of the needle hole is 1.5 to 1.8 mm.

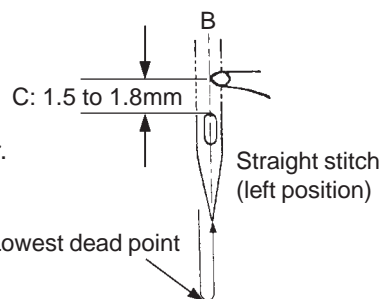

If the dimension is not correct, perform following adjustment.

How to adjust

1. Loosen the 2nd set screw in the hook driving gear.
2. Set the zigzag width to 5 mm. (Select "03" and make max. needle throw.)
3. Turn the handwheel by hand, and loosen the 1st set screw in the hook driving gear and move the gear in the rotating direction so that the tip of the blade point of the hook comes to the center of the rear side of the needle when the needle throws to the right side and the needle bar comes up (1.7 ± 0.075 mm) from the lowest dead point.

At this time, pay attention to both the rotating direction and the axis direction, and adjust by temporarily tightening the 1st set screw as the black lash of the hook driving gear with the hook side gear changes according to the position of the hook driving shaft direction of the hook driving gear.

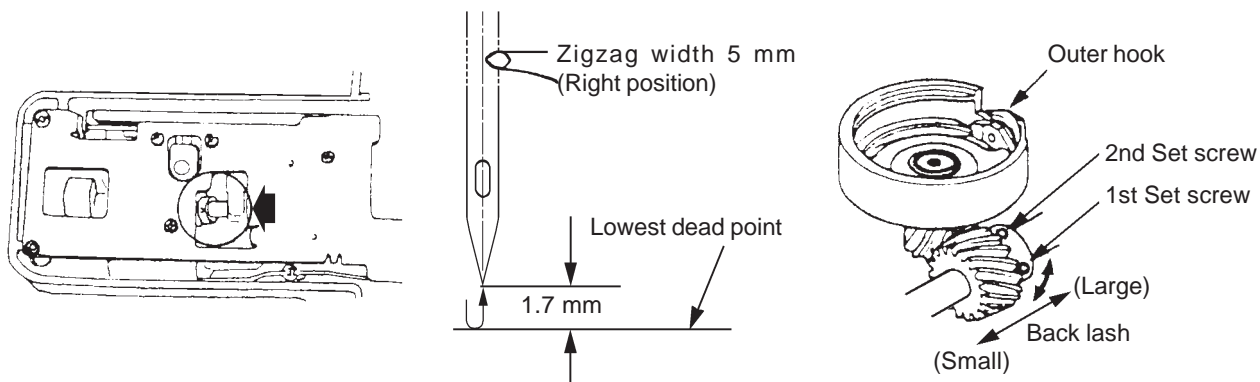

6. Clearance between the needle and the blade point

- Remove the front panel. (Page 6)
- A clearance of 0.02 to 0.07 mm should be provided between the center of the needle and the blade point of the hook when the needle which is ascending from its lowest dead point meets the blade point.
- Check the clearance with the left and right needle entry points.

How to adjust

- 6-1** ○ Loosen screw ① in the stopper and clamping screw ② in the needle bar frame stud.
- Adjust the clearance between the needle and the blade point using adjusting screw ③.
- 6-2** ○ If the clearance between the blade point and the left-hand side needle is different from that between the blade point and the right-hand side needle, loosen screw ④, and move needle bar frame stud (asm.) ⑤ in the right or left.

* Tightening screws ② and ③ change the clearance. Check the clearance with the screws tightened. Tighten screw ④ while pressing the stopper against the frame.

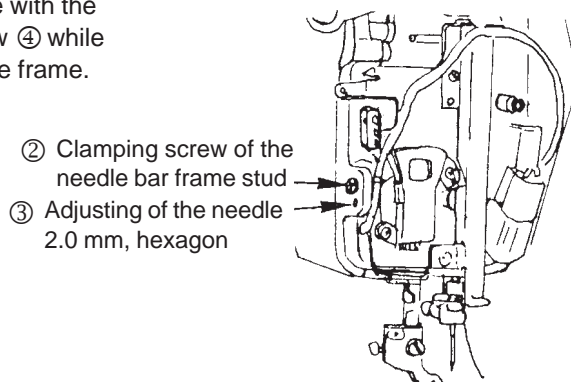
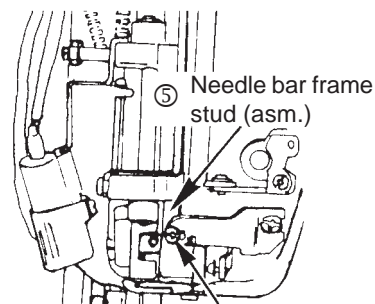
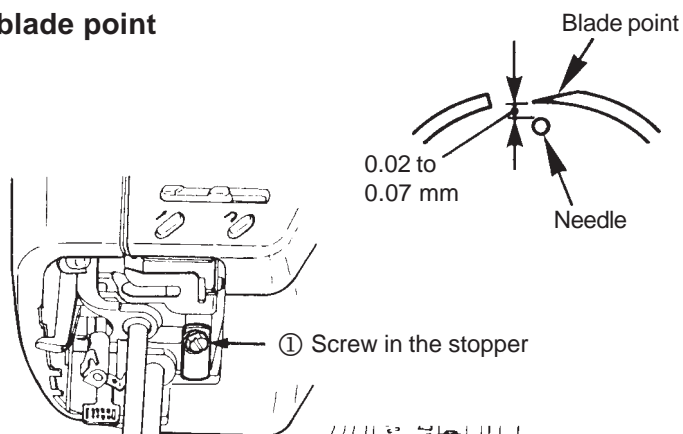

7. Position of the detent plate of the inner hook (position of the bobbin case opening lever)

- Remove the throat plate (needle plate).
- Press the detent plate of inner hook against the detent plate attaching boss.

How to adjust

- Loosen screw ①, and adjust the position of the detent plate.

* Inner hook ② should be flush with the detent plate.

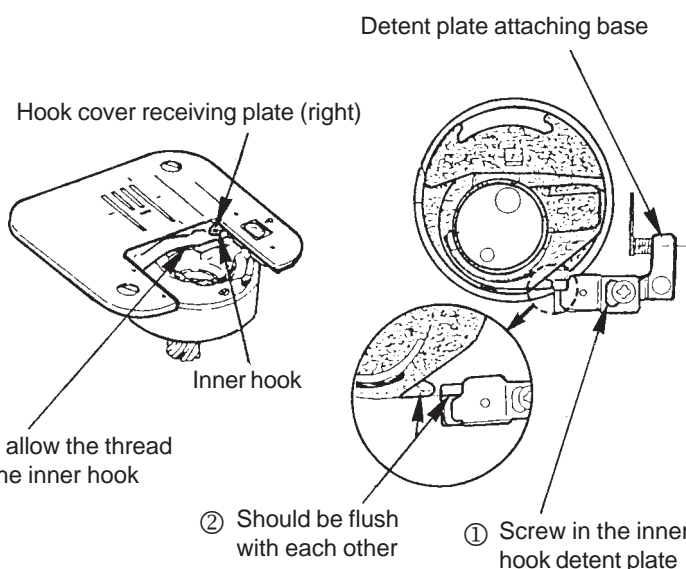

8. Adjust the longitudinal feed

Preparation for adjustment

1. Hold pressing the start/stop button after turning OFF the power switch. Then turn on the machine so that the pattern is changed over to the pattern for adjusting the darning, and "dr" is displayed in the LCD.

How to adjust

(Program for adjustment)

The sewing conditions

2. 2-layer cotton broad, Dual Duty #50 (for both needle and bobbin threads) and automatic high speed
3. Sew three pieces or more of the stitch pattern under the conditions of step 2) above.
Turn the pattern adjusting knob so that the last seam of "B" is overlapped as illustrated in the figure below.
4. Sew BH (buttonhole) and check the stitch pitch.
5. After the adjustment, in case the screwdriver groove of the pattern adjusting knob is not flush, remove the cover of the pattern adjusting knob and rearrange so that the knob is in the flush position.

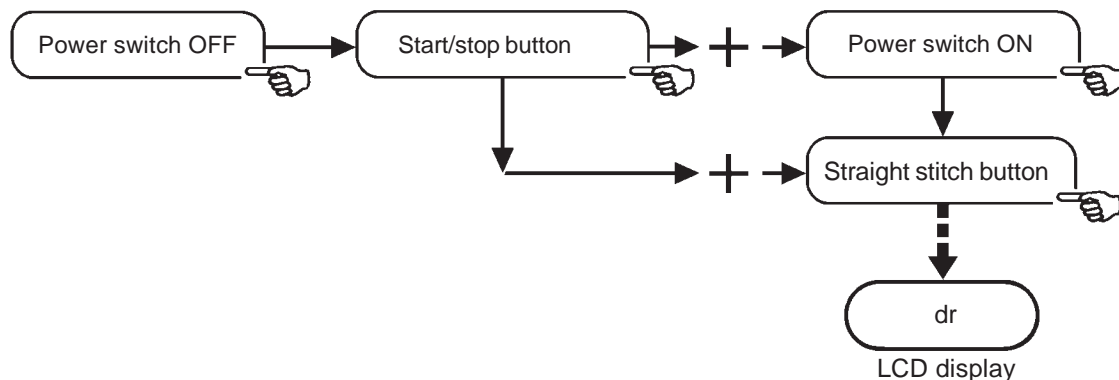
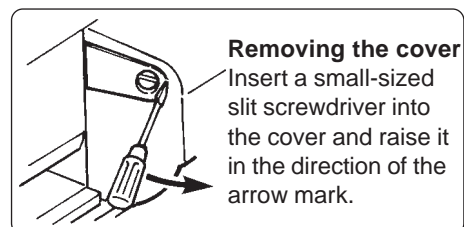
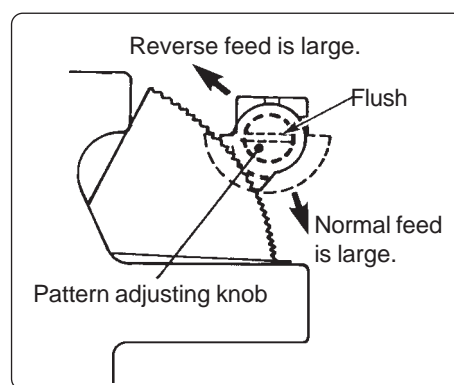
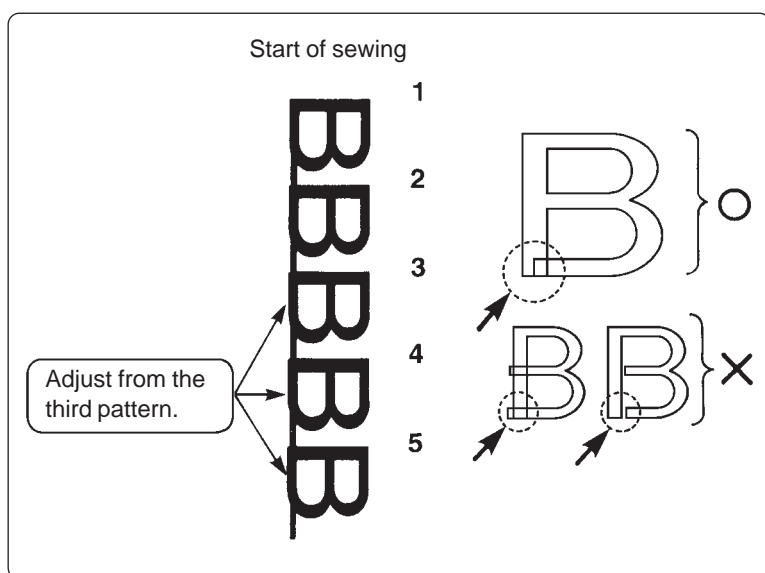

9. Buttonhole change-over switch

- Remove the top cover. (Page 5)

Adjustment

1. Attach the BH (buttonhole) presser foot in place and lower the presser foot.
2. Lower the BH (buttonhole) change-over lever.
3. Select BH (buttonhole) (#13). Normally, in this state, BH (buttonhole) error mark is not indicated on the LCD indication panel.
4. Loosen screws ① and ② in the BH (buttonhole) switch base Y.
When Y is moved while using screw ① as a fulcrum, the BH (buttonhole) error mark is indicated.
5. Gradually move Y in the direction to make the BH (buttonhole) error mark go out, stop Y at the position where the mark goes out, and tighten screws ① and ②.
In addition, move the presser foot up or down to check that the mark goes out.
6. Place a sheet of paper under the BH (buttonhole) presser foot and make the sewing machine run idle without threading to check the return position of the buttonhole and stop state. Perform re-adjustment if there is any trouble.

When these tests are OK, thread the machine head and perform the test sewing of the buttonhole.

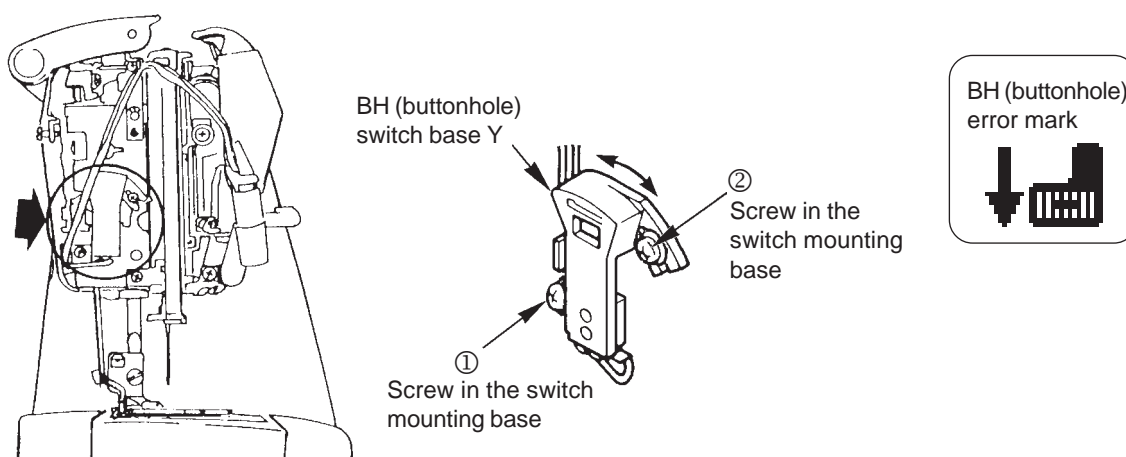

10. Vertical position of automatic threader hook

- Remove the front panel. (Page 6)
- The clearance provided between the top end of hook ② and the top end of the needle eyelet should be adjusted to 0.

How to adjust

- Bring the needle bar to its highest dead point.
Now, you can see the screw in the threading needle bar guide through clearance ①.
Loosen the screw, and adjust the position of the threading hook by moving the guide up or down.

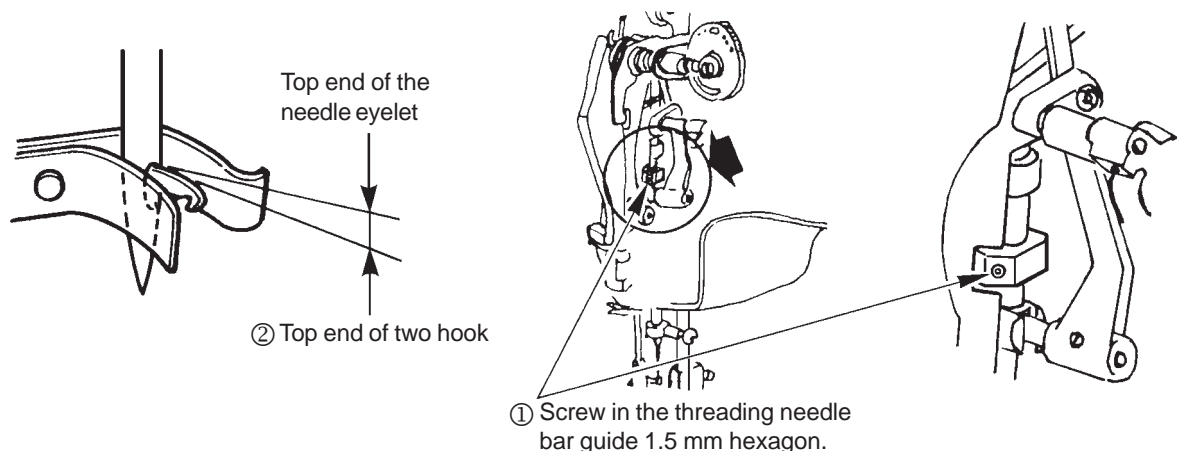

11. Adjusting the tension

11-1. Principles of the thread tension mechanism

1. There are thick threads to thin threads. Normal thread tension unit adjusts the thread tension by one thread tension unit against each thread.

HZL-T100, by adopting the principle by which the tension is individually secured according to the thickness of the thread used, enable the users to adjust the thread tension with ease.

[Principle diagram]

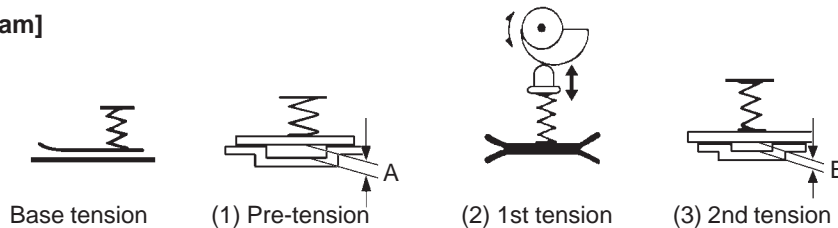

[Role]

- Base tension (untwisting)

Base tension performs to remove the twisting so as the thread twisting not to enter the thread paths.
(Attached in the rear side of the arm cover.)

- Pre-tension

Pre-tension is located at clearance A to correspond to tick thread and gives the tension to think thread.

Thick thread is given the necessary tension mainly by (1) + (2) + (3).

- 1st tension (main tension)

This tension basically gives the tension to thin thread.

This tension has the function of manual tension adjustment as well.

- 2nd tension

This tension is located at clearance B for medium-weight thread to correspond to medium-sized thread.
Medium-weight thread is given the proper tension mainly by (2) + (3).

Thread thickness and effect tension			
Thread thickness	(1) Pre-tension	(2) 1st tension	(3) 2nd tension
Thin	—	○	—
Medium	—	○	○
Thick	○	○	○

2. External adjusting function to re-set the thread tension is provided for users' choice.

The mechanism that the tension cam holds the dial can disengage the engagement of the both ratchets by inserting a small-sized slit screwdriver or the like.

By shifting the both position in this state, re-setting of the dial graduation can be performed.

[Configuration diagram]

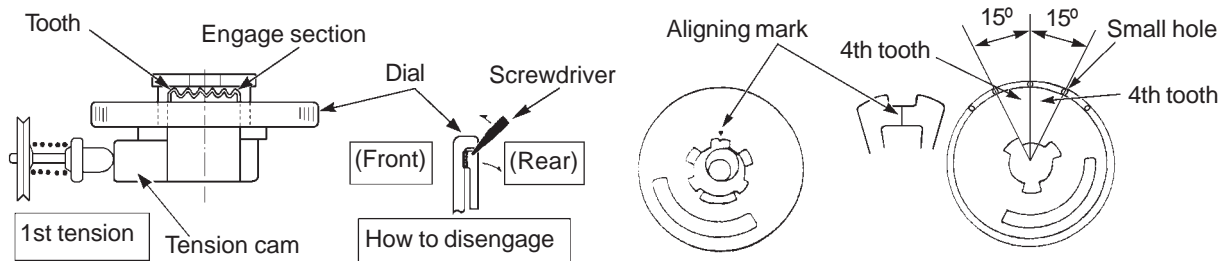

How to adjust

- In case adjusting the tension after assembling the front panel and arm cover is desired, the dial of 1st tension can be adjusted because of the machine construction.

1. By inserting a small-sized slit screwdriver into the center of the groove located in the rear side of the tension knob, the engagement of the knob and the tension cam be disengaged.

2. Adjustment can be performed by moving the tension cam or the knob to the right or left. However, the adjustment should be performed within the 4th tooth of the right or left side.

In case the adjustment more than 4th tooth is necessary, re-check the tension components.

(For the angle, the adjustment is in the range of 15° left or 15° right. For the reference there are 4 small holes at the rim of the knob and the angle between the respective small holes is in a unit of 15° each.)

11-2. Opening amount of the pre-tension disk

- Remove the top cover.

How to adjust

- When raising the operation lever, loosen the screw ① and move the tension disk releasing link adjuster plate to the left and so that the pre-tension disk opens by approx. 1 mm. Then securely tighten the screw ①.

Caution

- Install the pre-tension (asm.) so that the pre-tension disk is aligned with the 1st tension disk. Then securely tighten the screw ②. However, the tension of the pre-tension is a fixed type and cannot be adjusted.

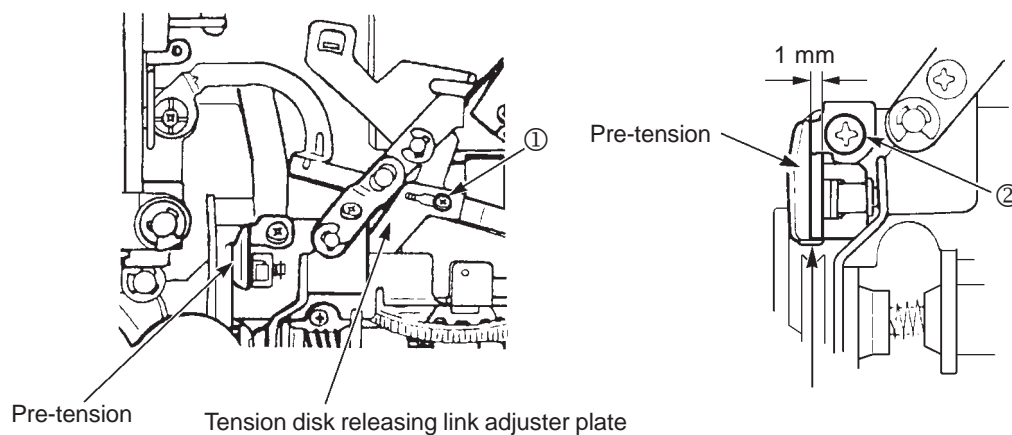

11-3. Opening amount of the 2nd tension disk

- Remove the top cover and front panel.

- When raising the operation lever, loosen the screw ③ and move the tension disk releasing plate so that a clearance of 1 to 1.5 mm is provided between the 2nd tension disk and the face plate. Then securely tighten the screw ③.

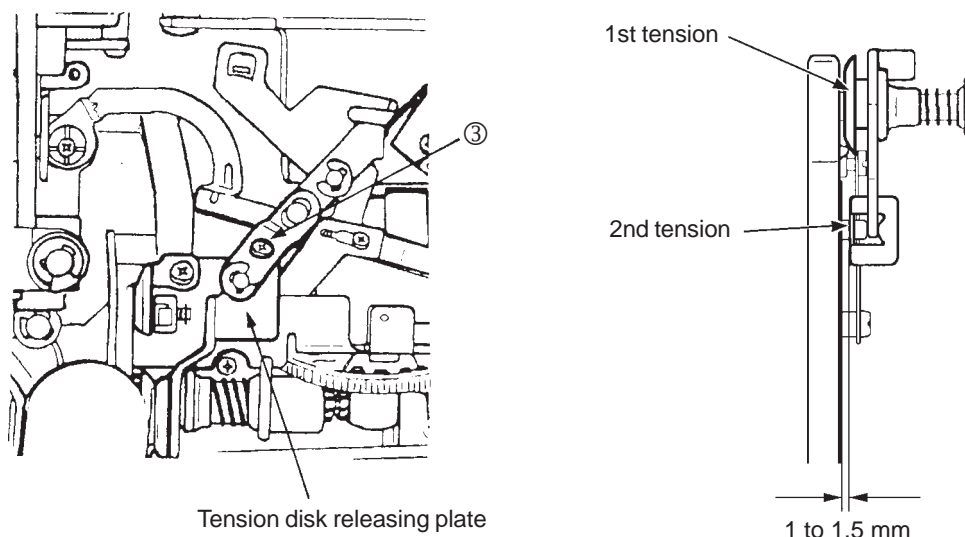

11-4. Adjusting the needle thread tension

· Remove the face cover, top cover front panel.

How to adjust

1. Remove to the front panel and make a condition that the arm cover is attached.
 2. Place right above the number ③ among the numbers on the tension knob.
 3. Raise the operation lever, and pass a fine thin thread of polyester through the base tension, pre-tension and 1st tension.
- * Use a thread of diameter that can pass through the groove section of the pre-tension disk and that the tension of the pre-tension is not put on the thread.

Example: Polyester thread 70D/1X2(Z)

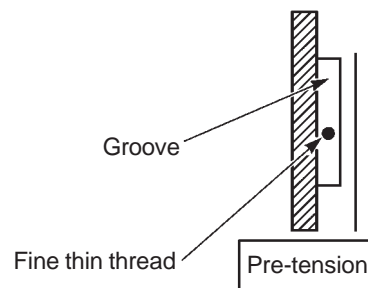

4. Lower the operation lever, and attach the tip of fine thin thread to the tension gauge. Then loosen the nut ① and turn the screw ③ so that the tension becomes $0.107 \pm 0.019\text{N}$ ($11 \pm 2\text{g}$). (The thread should not touch the components around the 2nd tension.)
 - Turn the screw ③ clockwise → Decrease the tension.
 - Turn the screw ③ counterclockwise → Increase the tension.
5. After the adjustment, tighten the nut ①.
6. Then adjust the total tensions (base tension, pre-tension, 1st tension and 2nd tension).
Replace the thread with the Dual Duty #50, and loosen the nut ② of the 2nd tension and turn the adjusting screw ④ so that the total tensions become $0.294 \pm 0.019\text{N}$ ($30 \pm 2\text{g}$).
7. After re-checking the tension, perform a trial sewing.
If further adjustment is necessary, make a fine adjustment using the screw ④ of the 2nd tension.
8. Tighten the nut ② to fix it.

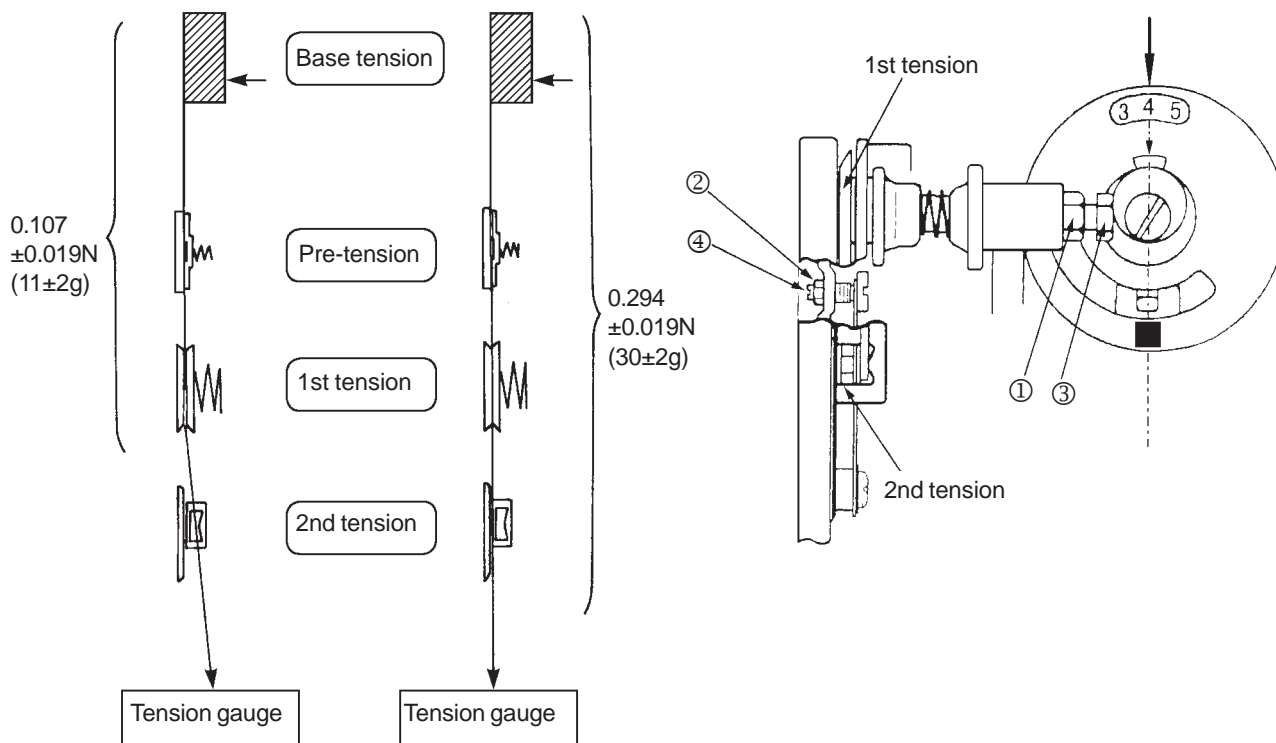

11-5. Adjusting the bobbin thread tension

- Remove the throat plate (needle plate).

How to adjust

1. Position the inner hook and the tension gauge as shown in the figure, and adjust using the adjusting screw "8" so that the tension becomes $0.127 \pm 0.0098\text{N}$ ($13 \pm 1\text{g}$) with the Dual Duty #50 thread.

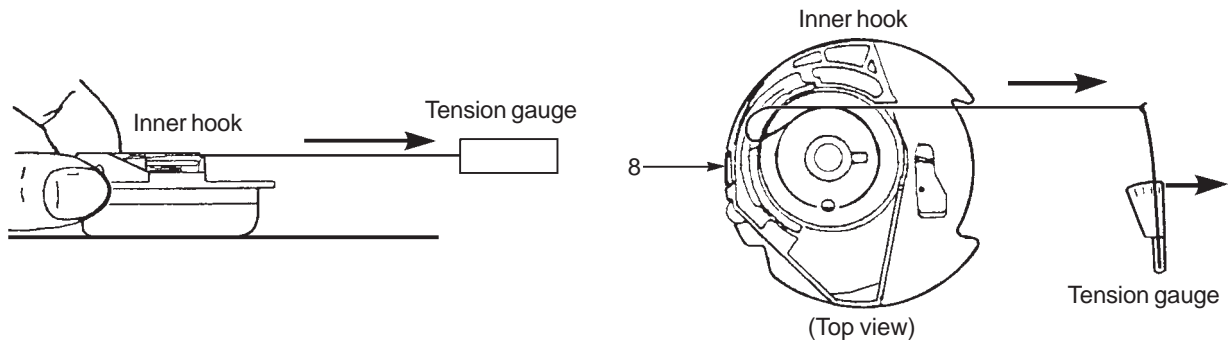

Automatic thread trimmer components

1. Position of the thread trimming switch and one-stitch switch

- Remove the top board and the face plate cover. (Page 5)
- 1-1 The one-stitch switch should turn ON when raising the presser foot, or turn OFF when lowering it.
Loosen screw ① in the one-stitch switch, and make the adjustment.
- 1-2 ○ The one-stitch switch should turn ON when the operating lever is set at the thread trimming retaining position.
On the other hand, the thread trimming switch should turn OFF at the aforementioned moment.
- The thread trimming switch should turn ON when the lever is further lowered from the retaining position.
Make the adjustment using screw ② in the thread trimming switch.

② Screw in the thread trimming switch

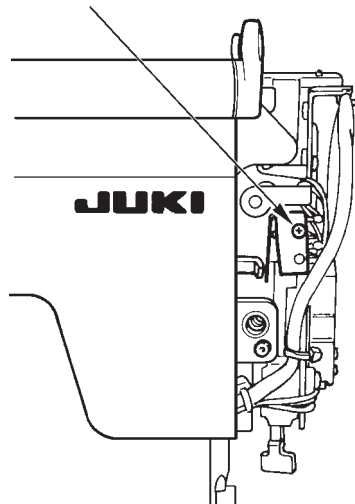

① Screw in the one-stitch switch

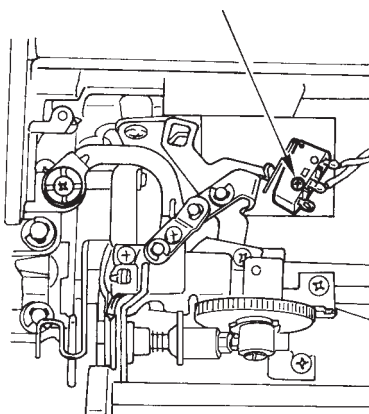

2. Timing of thread trimming

- Remove the top board and the throat plate (needle plate). (Page 5)
- The timing adjusting groove (positioning groove) in the thread trimming cam should come to the top when the needle bar is in its lowest dead point.
- * How to check the timing of thread trimming
Lower the operating lever until the needle bar is brought its lowest dead point. At this time, the moving knife should be move a little.
(The moving knife moves a little since the moving knife roller fits in the timing adjusting groove in the thread trimming cam.)

How to adjust

- Loosen two screws ① in the main shaft pulley, and adjust the timing of thread trimming.

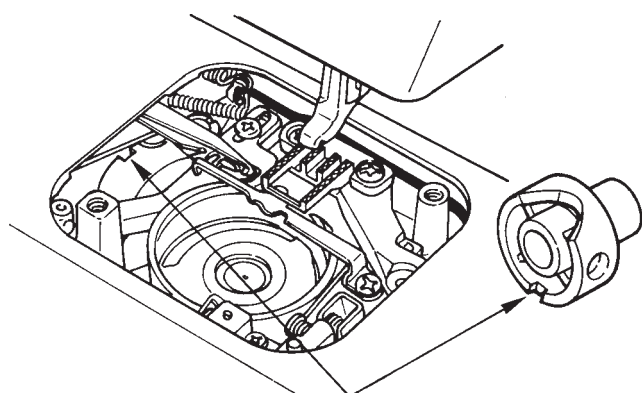

* Timing adjusting groove
in the thread trimming cam

① Screw in the main shaft pulley 2.0 mm hexagon

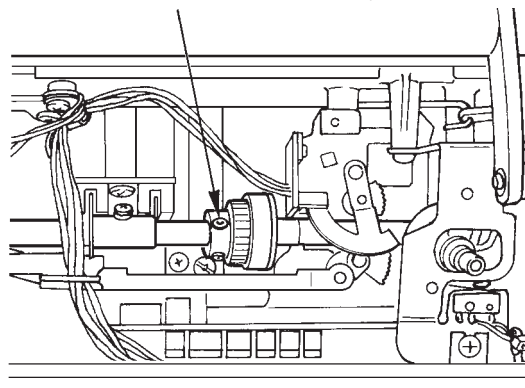

3. Position of the moving knife (draw-in position of the moving knife)

- Remove the throat plate (needle plate).
- A clearance of 0.5 to 1.5 mm should be provided between the moving knife blade and the end face of square hole in the moving knife guide plate (upper) when lowering the operating lever.

How to adjust

1. As for the left and right stopping positions of the moving knife guide plate, temporarily tighten the screw ① at the extreme right front position of the moving knife guide plate. (Secure the clearance of 0.7 mm from the left end of the feed dog.)
2. Turn OFF the power switch and turn the handwheel in a condition that the operation lever is lowered. Then slowly return the moving knife.
3. When the blade section of the moving knife has passed the right end of the knife guide plate (upper), the movement of the moving knife does not change against the movement of handwheel. At that position, stop turning the handwheel.
4. At that position, check the position and dimension of the moving knife and the knife guide plate. Then loosen again the screw ① and make a fine adjustment of the position of the knife guide plate so that dimensions 0.5 to 1 mm (C) and 1.0 mm or less (D) are covered.

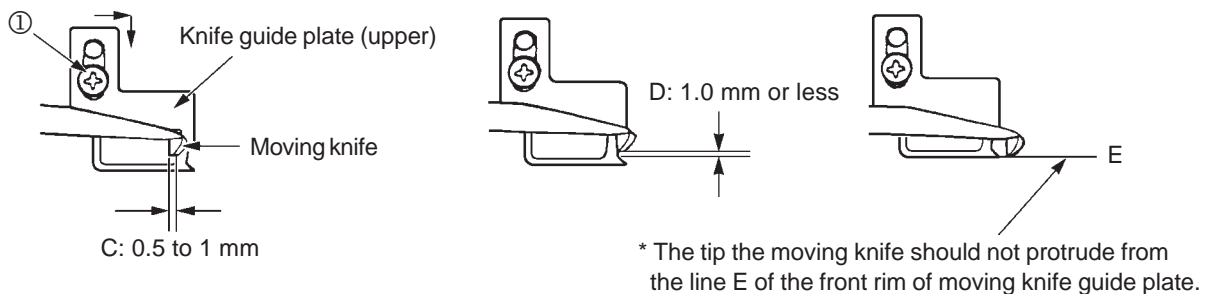

4. Adjustment of the knife driving link (Clearance between the driving link4 roller and the thread trimming cam)

- Remove the throat plate
- A clearance of 0.5 mm should be provided between the thread trimming cam and the driving roller when the operating lever is positioned horizontally.

How to check

The moving knife should move (by approximately 0.7 to 1.0 mm) when raising/lowering the presser foot with the needle bar positioned in the intermediate position of its strike.

How to adjust

- Loosen screw ① in the collar, and adjust the knife driving link by turning the lower eccentric collar. The eccentric collar should face you.

- ① Screw in the eccentric collar of knife

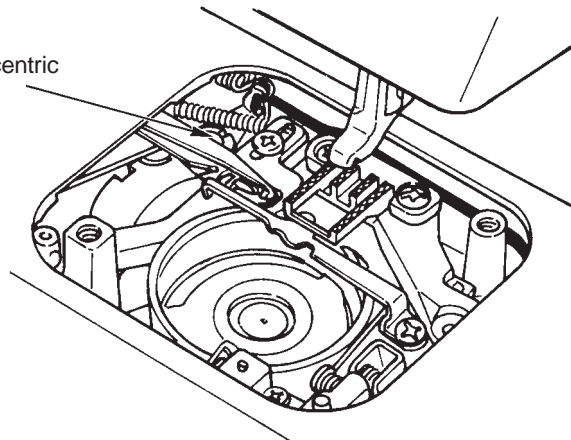

5. Adjustment of the knife disengaging plate (Engagement of the disengaging plate and the thread trimming cam)

- Remove the throat plate (needle plate) and the front panel.
- A clearance of 0.5 ± 0.3 mm should be provided between knife disengaging plate ① and moving knife link roller ② when the operating lever is positioned horizontally.

How to adjust

- Loosen screw ③, and adjust the knife disengaging plate using the eccentric shaft.

How to check

- Turn eccentric shaft ④ until moving knife change-over link ⑤ loosen once.
- Then, turn eccentric shaft ④ until the moving knife change-over link. Tighten screw ③ at that position.

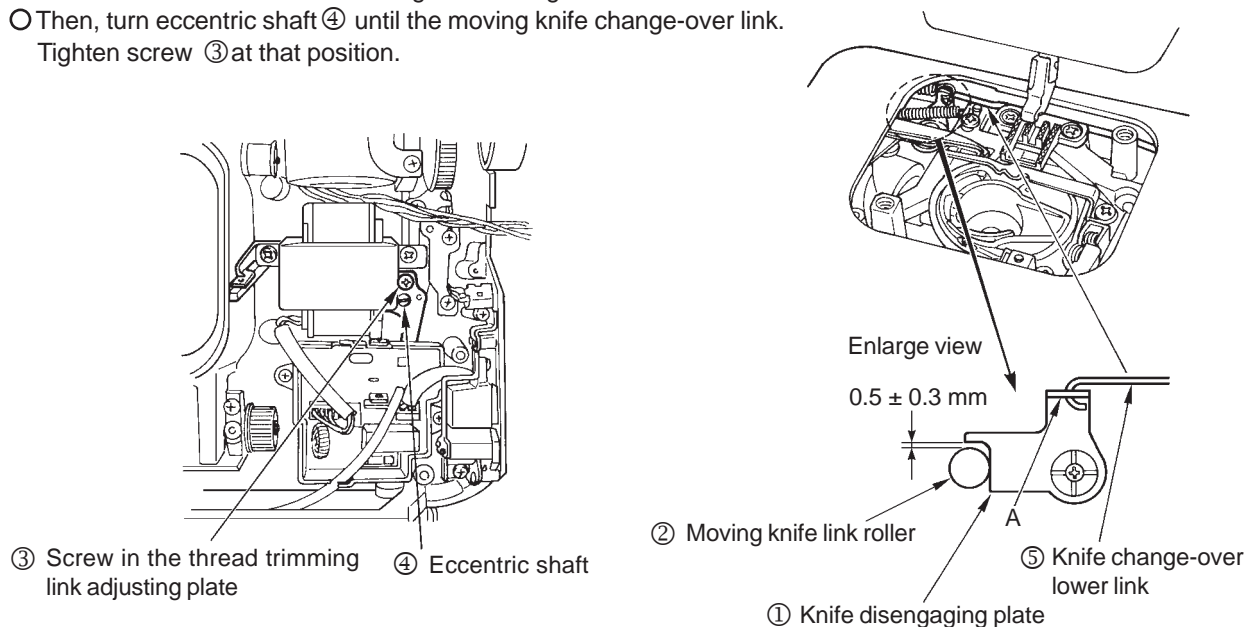

6. Loooper stroke (vertical stroke)

- Remove the throat plate (needle plate) and the bed base. (Page 6)
- Remove the cylinder bed lower cover. (Page 6)
- When the operating lever by one step (approx. 43°), looper ① should ride over projecting section ② of the inner hook.
- * The looper should not come down even if further lowering the lever (approx 55°).

How to adjust

Loosen screw ③, and move it to the right or left.

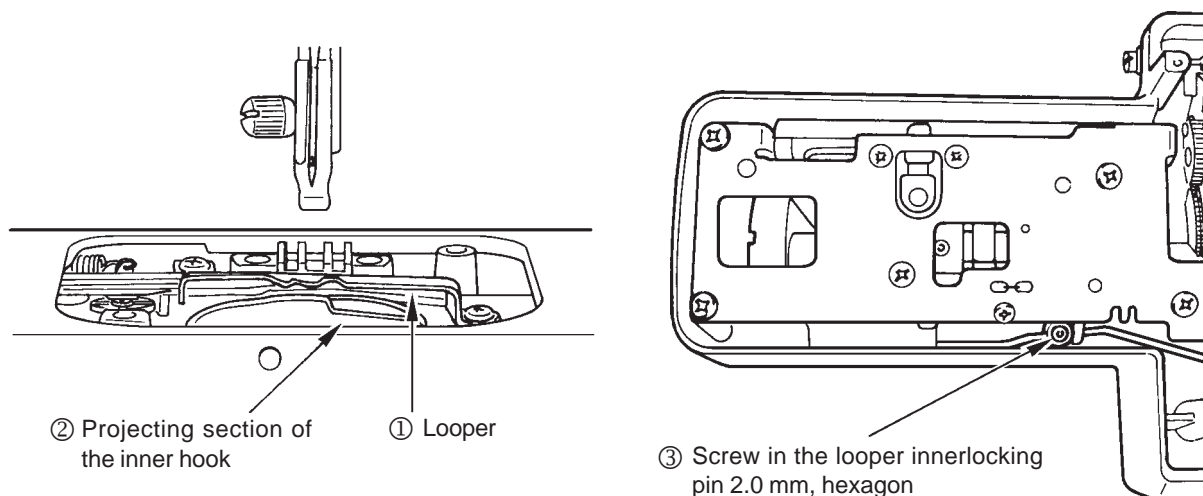

7. Adjusting the position of knife

○ Remove the throat plate (needle plate).

[Position of the moving knife]

How to adjust

1. Turn OFF the power switch, and turn the handwheel in a condition that the operation lever is lowered to protrude to moving knife.
Then slowly return the handwheel.
2. When the section B of the moving knife base has come to the looper position in the figure, stop the movement of the moving knife.
Then check the position and dimension, 0 to 0.5 mm, of the looper and the moving knife base. If the position is incorrect, perform following procedure.
3. Following the aforementioned procedure 1, protrude the moving knife, and slightly loosen two set screws ① in the moving knife base to the extent that the moving knife base can be moved.
4. Turn the eccentric shaft ② and adjust the position and dimension. Then securely tighten the set screws ①.

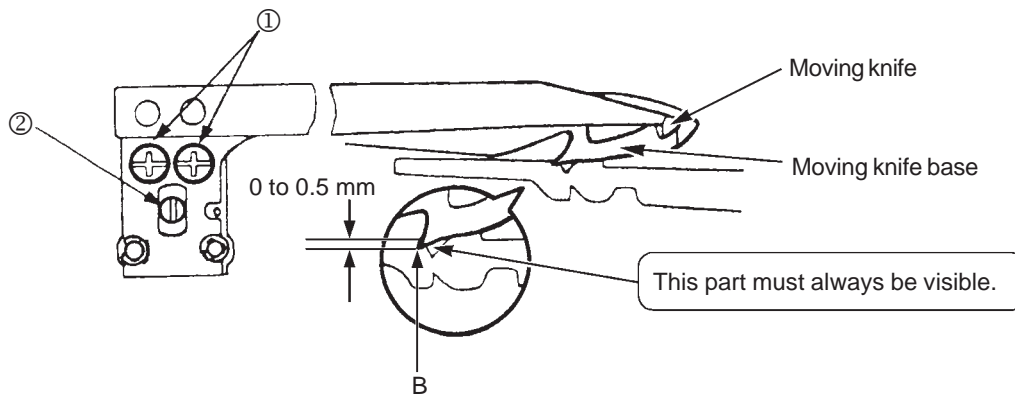

8. Stop position of thread trimmer

○ Remove the face cover, top cover and front panel.

How to adjust

1. Set the operation lever in thread trimming (lower the lever) condition.
2. Turn the motor pulley by hand, and stop at the position where the needle bar stops.
3. At this time, measure the distance from the upper surface of the throat plate (needle plate) to the tip of needle.
Make sure that the distance is 12.56 ± 0.3 mm.
4. Loosen two screws ① and adjust the position by sliding the thread trimming link installing plate A up or down.
In case needle is excessively low → Lower the A
In case needle is excessively high → Raise the A

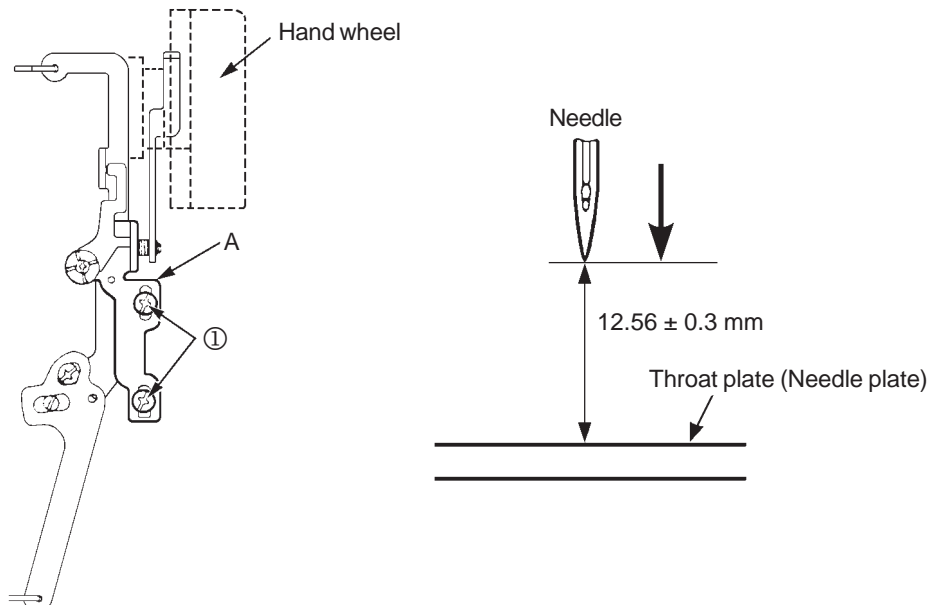

JUKI®

JUKI CORPORATION

8-2-1, KOKURYO-CHO,
CHOFU-SHI, TOKYO 182-8655, JAPAN
PHONE : (81)3-3480-5034
FAX : (81)3-3480-5037

Copyright © 2002 JUKI CORPORATION.
All rights reserved throughout the world.

www.promelectroavtomat.ru