

smart™  
BY PFAFF



OWNER'S MANUAL

100 S

[www.promelectroavtomat.ru](http://www.promelectroavtomat.ru)

This household sewing machine is designed to comply with IEC/EN 60335-2-28 and UL1594

## IMPORTANT SAFETY INSTRUCTIONS

When using an electrical appliance, basic safety precautions should always be followed, including the following:

Read all instructions before using this household sewing machine.

### DANGER - To reduce the risk of electric shock:

- A sewing machine should never be left unattended when plugged in. Always unplug this sewing machine from the electric outlet immediately after using and before cleaning.
- Always unplug before relamping. Replace bulb with same type rated 10W (110-120V), 15W (220-240V).

### WARNING - To reduce the risk of burns, fire, electric shock, or injury to persons:

- Do not allow to be used as a toy. Close attention is necessary when this sewing machine is used by or near children or infirm person.
- Use this sewing machine only for its intended use as described in this manual. Use only attachments recommended by the manufacturer as contained in this manual.
- Never operate this sewing machine if it has a damaged cord or plug, if it is not working properly, if it has been dropped or damaged, or dropped into water. Return the sewing machine to the nearest authorized dealer or service center for examination, repair, electrical or mechanical adjustment.

- Never operate the sewing machine with any air openings blocked. Keep ventilation openings of the Sewing machine and foot controller free from the accumulation of lint, dust, and loose cloth.
- Keep fingers away from all moving parts. Special care is required around the Sewing machine needle.
- Always use the proper needle plate. The wrong plate can cause the needle to break.
- Do not use bent needles.
- Do not pull or push fabric while stitching. It may deflect the needle causing it to break.
- Switch the sewing machine off ("0") when making any adjustment in the needle area, such as threading needle, changing needle, threading bobbin, or changing presser foot, etc.
- Always unplug the sewing machine from the electrical outlet when removing covers, lubricating, or when making any other user servicing adjustments mentioned in the instruction manual.
- Never drop or insert any object into any opening.
- Do not use outdoors.
- Do not operate where aerosol (spray) products are being used or where oxygen is being administered.
- To disconnect, turn all controls to the off ("0") position, then remove plug from outlet.
- Do not unplug by pulling on cord. To unplug, grasp the plug, not the cord.

## SAVE THESE INSTRUCTIONS

## **Congratulations**

As the owner of a new sewing machine, you are about to begin an exciting adventure in creativity. From the moment you first use your machine, you will know you are sewing on one of the easiest to use sewing machines ever made.

May we recommend that, before you start to use your sewing machine, you discover the many advantages and the ease of operation by going through this instruction, step by step, seated at your machine.

To ensure that you are always provided with the most modern sewing capabilities, the manufacturer reserves the right to change the appearance, design or accessories of this sewing machine.

[www.promelectroavtomat.ru](http://www.promelectroavtomat.ru)

## List of contents

---

Principal parts of the machine .....	2/3	3-step zigzag stitch.....	25
Accessories .....	4	Straight stretch stitch and Stretch triple zigzag stitch .....	26
Extension table .....	5	Free-motion darning .....	27
Accessory tray .....	6	Darning .....	28
Connecting machine to power source .....	7	Free-motion monogramming and embroidering .....	29
Changing the light bulb.....	8	Quilting .....	30
Presser foot lifter .....	9	Twin needle (Optional) .....	31
Adjusting presser foot pressure.....	9	Maintenance.....	32
Attaching the presser foot holder/presser foot/seam guide.....	10	Troubleshooting guide .....	33
Winding the bobbin.....	11		
Inserting the bobbin.....	12		
Inserting and changing needle .....	13		
Threading the upper thread.....	14		
Thread tension .....	15		
Raising the bobbin thread .....	16		
Reverse sewing.....	17		
Changing sewing directions .....	17		
Removing your work.....	17		
Cutting the thread.....	17		
Matching needle/ fabric/ thread .....	18		
How to choose your stitch .....	19		
Straight stitching .....	20		
Zigzag stitching .....	21		
Overcasting stitches .....	22		
Buttonholes .....	23		
Zipper and piping .....	24		

## Principal parts of the machine

1. Tension dial
2. Bobbin thread guide
3. Thread take-up
4. Reverse lever
5. Thread cutting
6. Presser foot
7. Needle plate
8. Accessory tray
9. Bobbin winder
10. Stitch width dial
11. Stitch length dial
12. Stitch selection dial
13. Extension table

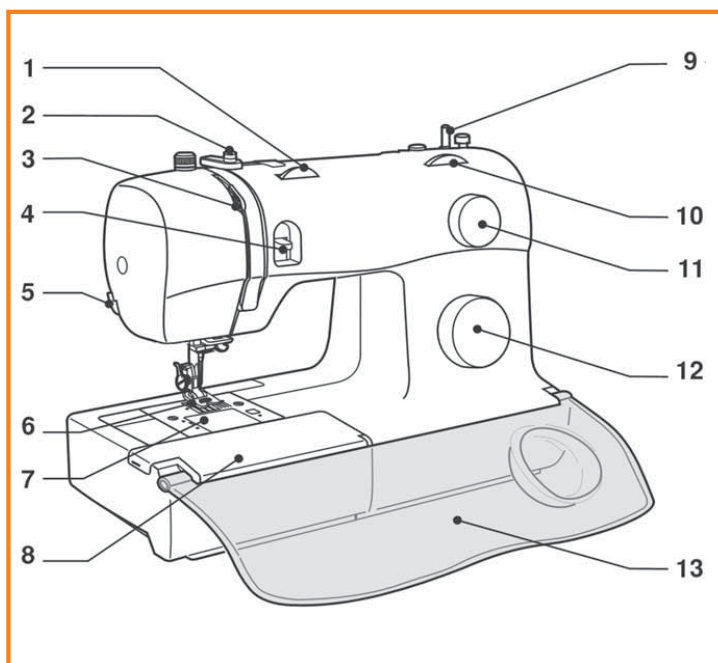

## Principal parts of the machine

- 14. Spool pin
- 15. Bobbin winder stop
- 16. Hole for second spool pin
- 17. Handwheel
- 18. Main switch
- 19. Main plug socket
- 20. Presser foot pressure
- 21. Upper thread guide
- 22. Handle
- 23. Presser foot lifter

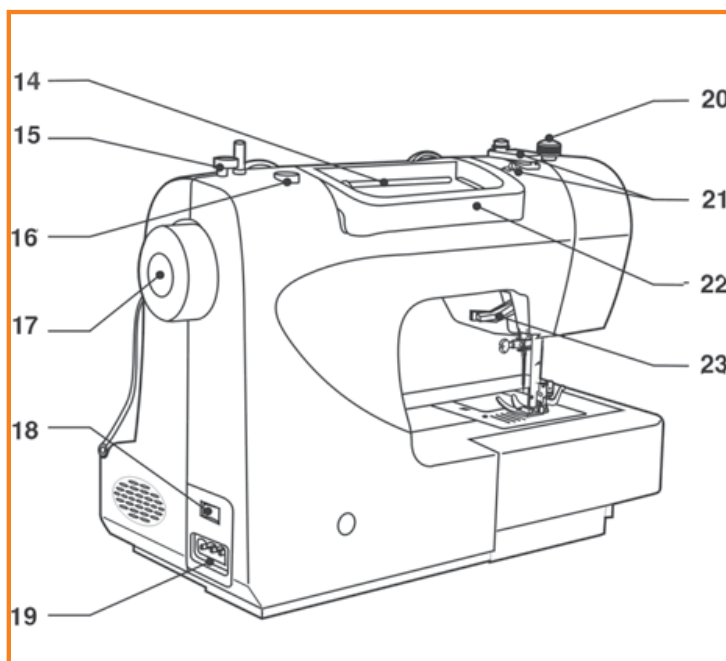

## Accessories

- a. Standard foot
- b. Zipper foot
- c. Buttonhole foot
- d. Quilting foot
- e. Second spool pin
- f. Seam ripper/ brush
- g. Seam guide
- h. Needles
- i. Spool caps
- j. Bobbins
- k. Off-set screwdriver
- l. Feed dog cover
- m. Free-motion/darning foot
- n. Hard cover
- o. Felt pad

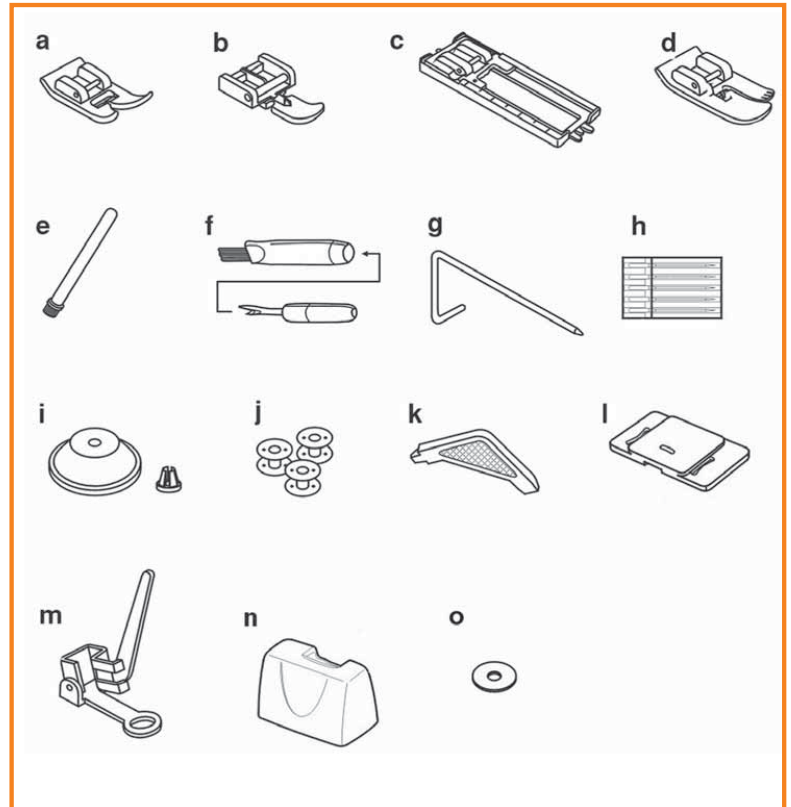



## Extension table

Before sewing, please follow the arrow (1) of the drawing, and pull down the extension table.

Extension table can help your fabric flow easier during sewing.

When the sewing machine is not being used, store the machine with the extension table folded up.

If you don't need extension table, you can also easily take it off.

First, move the extension table slightly to the left, as the arrow (2), to unhook the left side and then move it to the right unhooking the right side (3). You can then take it off.

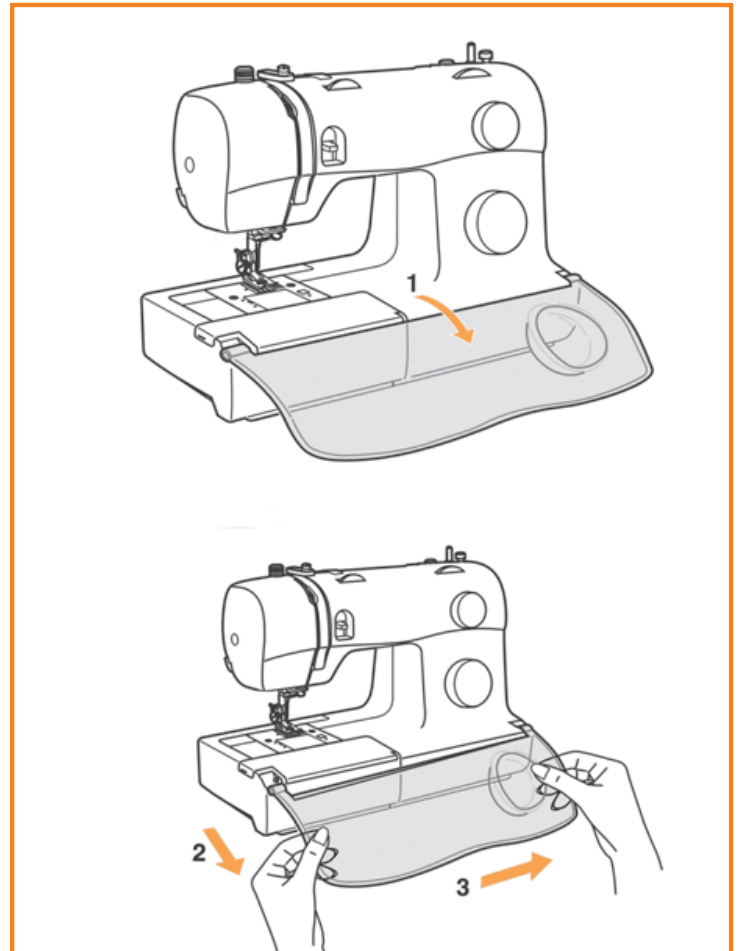

## Accessory tray

Keep the snap-in accessory tray horizontal, and push it in the direction of the arrow. (1)

Remove the accessory tray to sew cylindrical pieces such as sleeve cuffs.

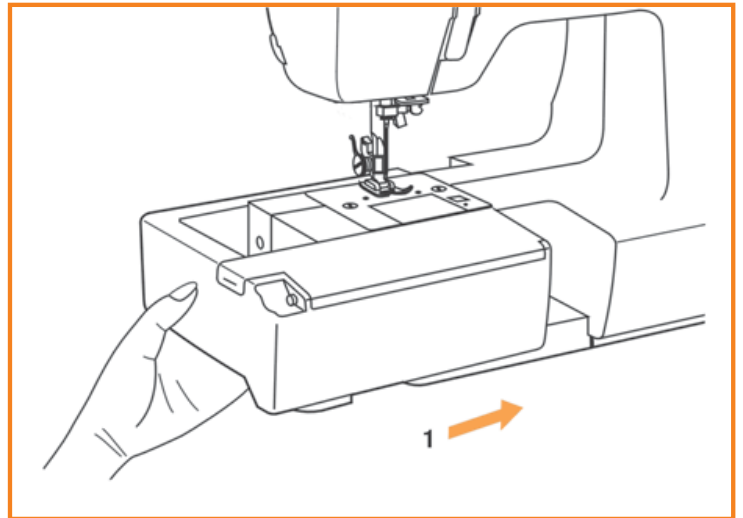

The inside of the snap-in accessory tray can be utilized to store your accessories.

To open, lift up at the point of the arrow. (2)

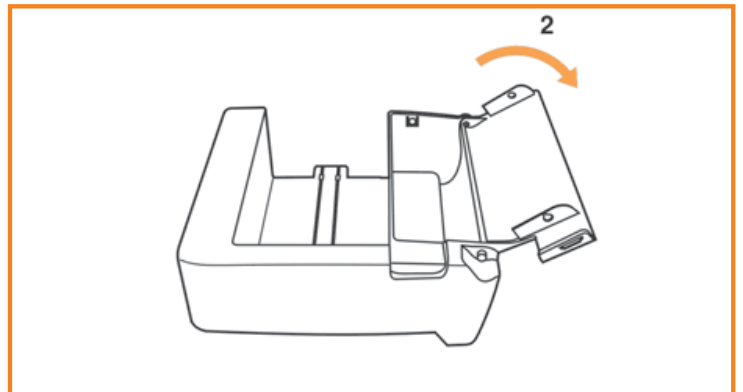

6

## Connecting machine to power source

Connect the machine to a power source as illustrated. (1)  
The appliance is equipped with a polarized plug which must be used with the appropriate polarized outlet.

### Attention:

Unplug power cord when machine is not in use.

### Foot control

Foot control regulates the sewing speed. (2)



### Attention:

Consult a qualified electrician if in doubt as to how to connect machine to power source.

Unplug power cord when machine is not in use.

The appliance must be used with the foot controller:

For USA and Canada, 110-120V: KD-1902

For Australia and Europe, 220-240V: KD-2902

### Sewing light

Press main switch (A) for power and light on "I".

### For USA and Canada

For appliance with a polarized plug (one blade is wider than the other). To reduce the risk of electric shock, this plug is intended to fit in a polarized outlet only one way. If it does not fit fully in the outlet, reverse the plug. If it still does not fit, contact a qualified electrician to install the proper outlet. Do not modify the plug in any way.

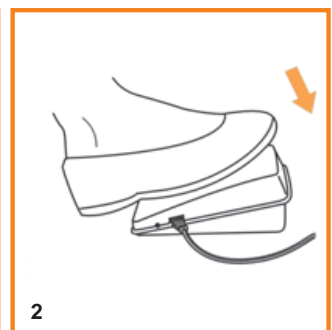
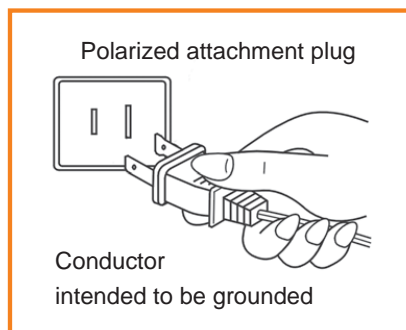
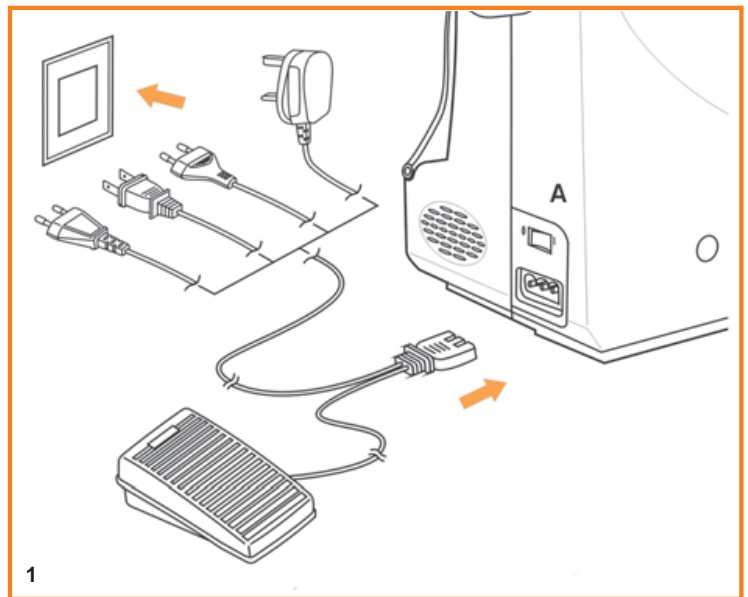

## Changing the light bulb

 Disconnect the machine from the power supply by removing the plug from the main socket!

Replace bulb with same type rated 10 watts (110-120V) or 15 watts (220-240V).

- Loosen screw (A) as illustrated. (1)
- Remove the cover (B).
- Turn the bulb half a rotation counter clock-wise (C) (2) and remove the bulb. Push the new bulb upward into the holder as far as it will go and turn it half a rotation in a clock-wise direction until it held firmly.
- Replace the cover and tighten screw.

Should there be any problem, ask your authorized Pfaff dealer for advice.

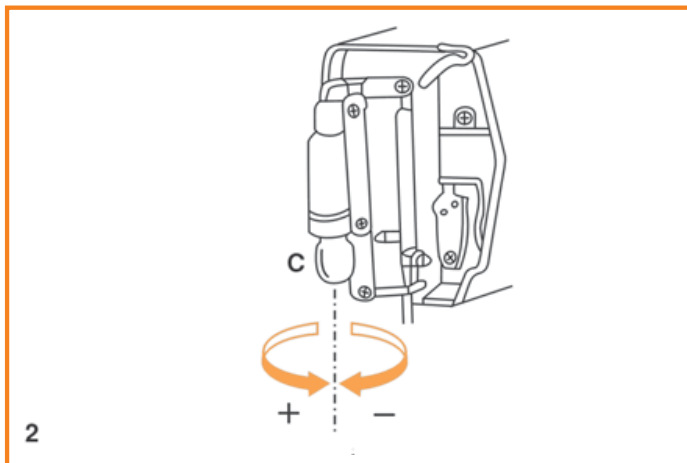
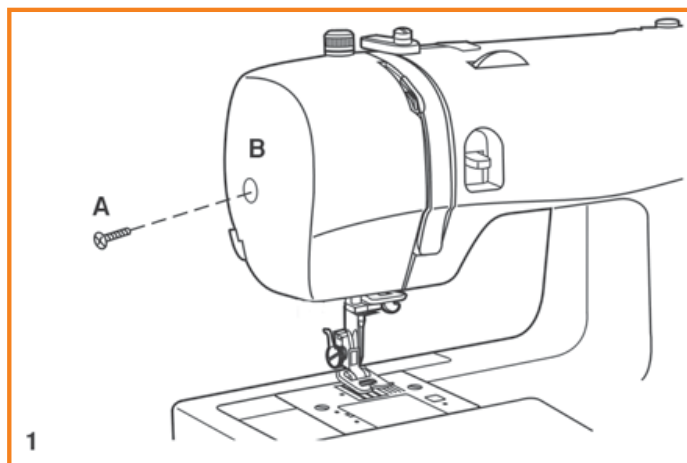

## Presser foot lifter

The presser foot lifter raises and lowers your presser foot. (A)

When sewing several layers or thick fabrics, the presser foot can be raised higher for easy positioning of the work. (B)

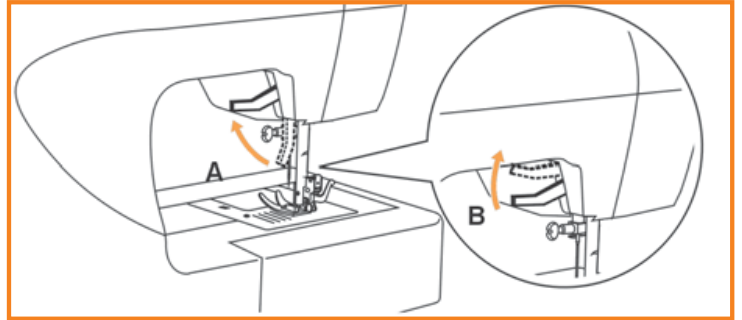

## Adjusting presser foot pressure

Standard presser foot pressure is set at "2".

The presser foot pressure of the machine has been pre-set and there is no need for change unless sewing particular type of fabric (light-or-heavy weight).

If you do need to adjust the presser foot pressure, turn the presser adjusting knob as shown in the picture.

For sewing very thin fabric, loosen the pressure by turning the knob counterclockwise. The knob will move upward and the pressure will decrease. If you keep turning the knob, it can be taken out. By that time, just turn the screw clockwise, until it locks back in place and readjust the pressure.

For heavy fabric, tighten the pressure by turning the knob clockwise and the knob will move downward and the pressure is increased. When the knob can not be moved any further, it has reached the bottom. Please do not turn it any more.

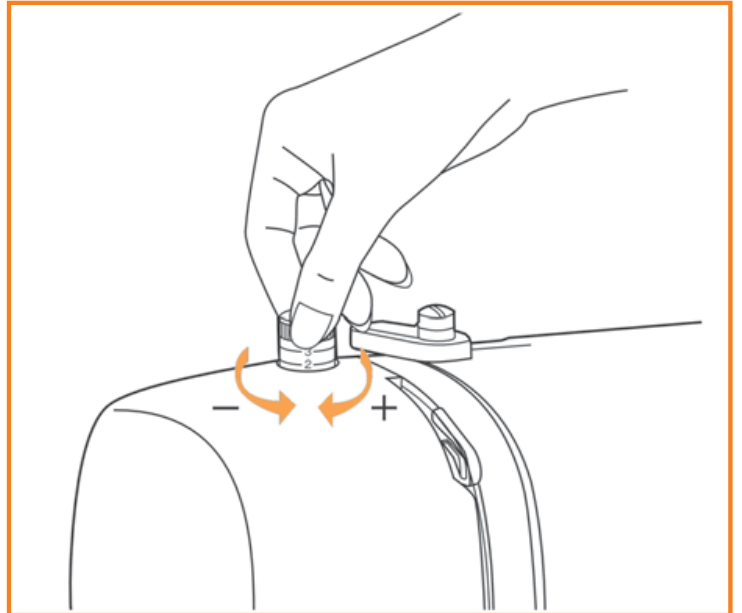

## Attaching the presser foot holder/presser foot/seam guide

Raise the presser bar (a). (1)

Attach the presser foot holder (b) as illustrated.

### Attaching the presser foot

Lower the presser foot holder (b) until the cut-out (c) is directly above the pin (d). (2)

Raise the lever (e).

Lower the presser foot holder (b) and the presser foot (f) will engage automatically.

### Removing the presser foot

Raise the presser foot. (3)

Raise the lever (e) and the foot disengages.

*Note: You can use the standard foot for all stitches.*

### Attaching the seam guide

Attach the seam guide (g) in the slot as illustrated.

Adjust according to need for hems, pleats, etc. (4)

### ⚠ Attention:

*Turn power switch to off ("O") when carrying out any of the above operations!*

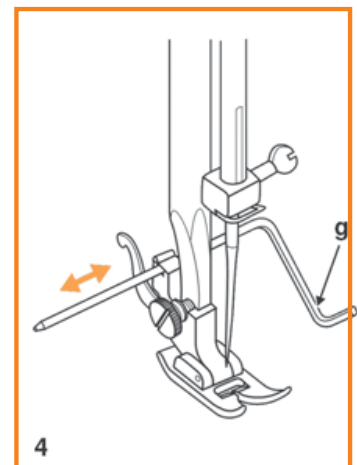
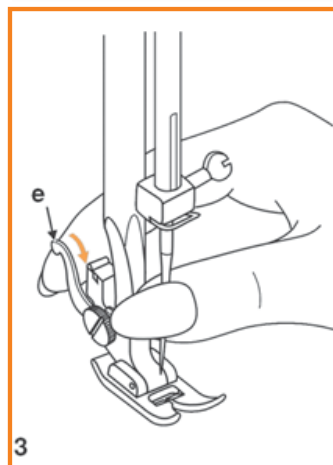
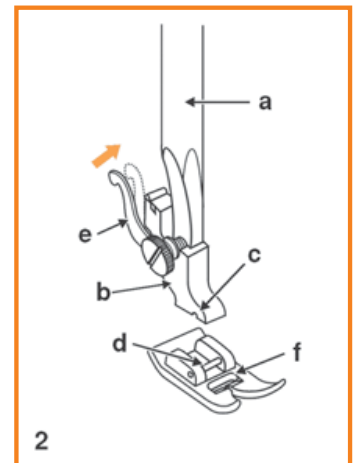
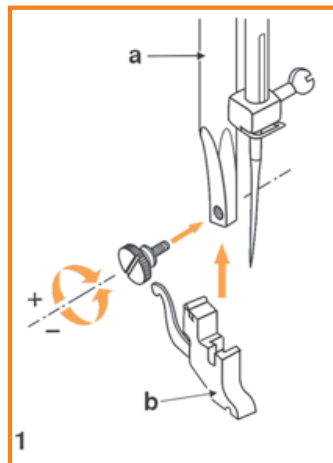

## Winding the bobbin

- Place thread and spool cap onto spool pin (1).  
For smaller spools of thread place spool cap with small side next to spool (2).
- Snap thread into thread guide (3).
- Wind thread clockwise around bobbin winder tension discs (4).
- Thread bobbin as illustrated and place on spindle (5).
- Push bobbin to right (6).
- Hold thread end (7). Step on foot control (8).
- Cut thread (9). Press bobbin to left (10) and remove.

### Please Note:

When the bobbin winder spindle is in "bobbin winding" position, the machine will not sew and the handwheel will not turn. To start sewing, push the bobbin winder spindle to the left (sewing position).

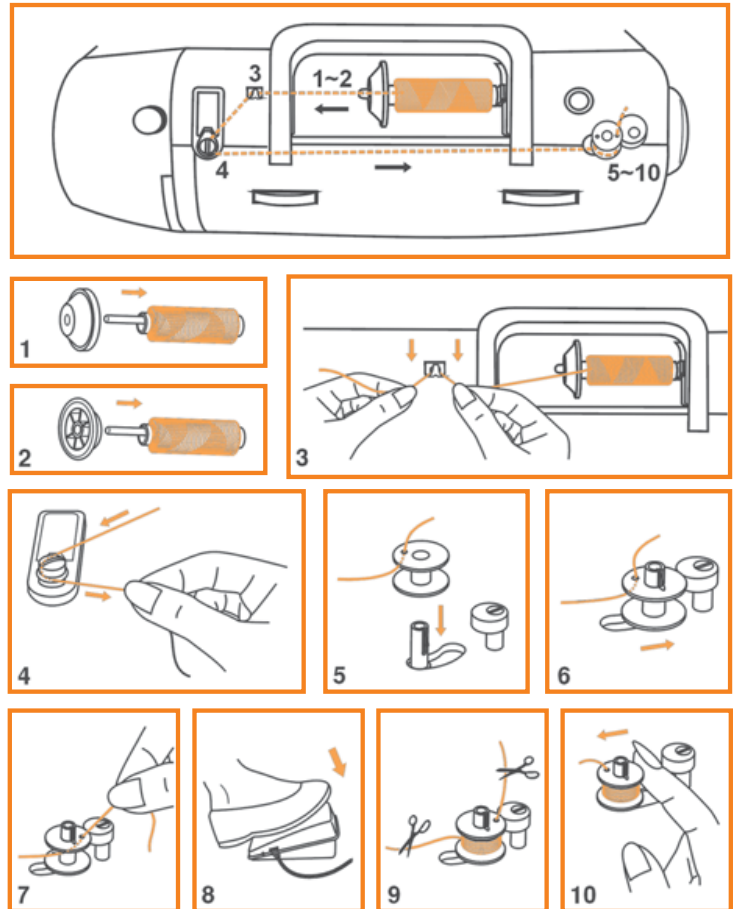

## Inserting the bobbin

When inserting or removing the bobbin, the needle must be in the highest position.

1. Insert the bobbin in the bobbin case with the thread running counterclockwise direction (arrow).
2. Pull the thread through the slit (A).
3. Draw the thread clockwise until it slips into the notch (B).
4. Pull out about 15 cm (6 inches) of thread and attach the bobbin cover plate. (C)

### Attention:

Turn power switch to off ("O") before inserting or removing the bobbin.

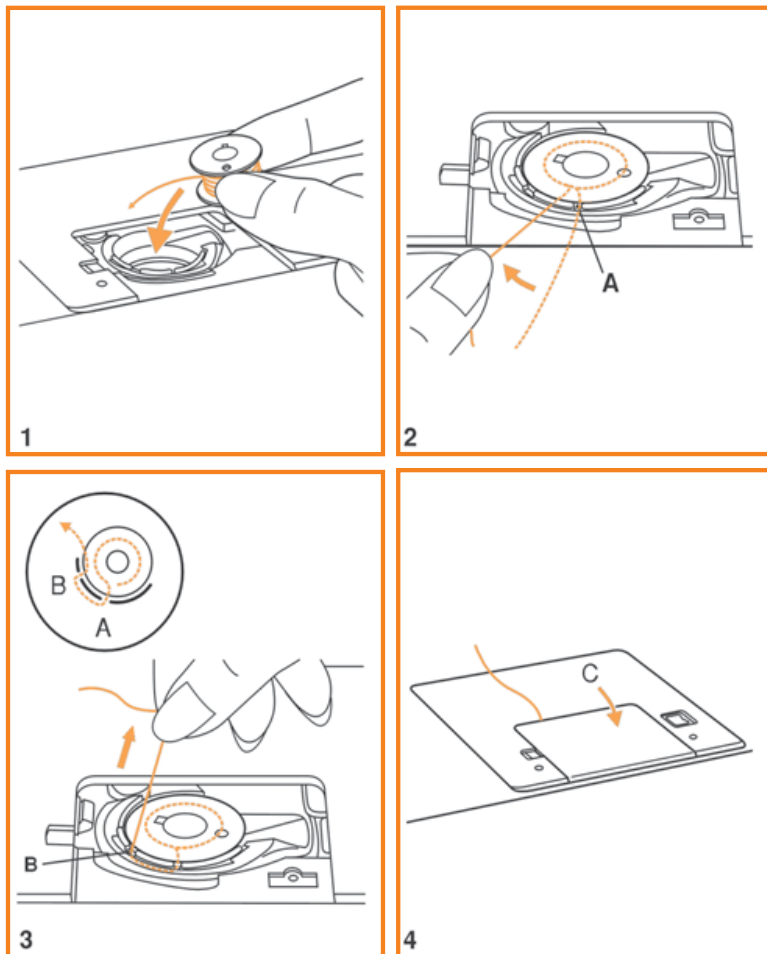



## Inserting and changing needle

Change the needle regularly, especially if it is showing signs of wear and causing problems.

Insert the needle following the illustrated instructions.

- A. Loosen the needle clamp screw and tighten again after inserting the new needle. (1)
- B. The flat side of the needle should be towards the back.
- C-D. Insert the needle as far up as it will go.

### Attention:

Turn power switch to off ("0").

Needles must be in perfect condition. (2)

Problems can occur with:

- A. Bent needles
- B. Damaged points
- C. Blunt needles

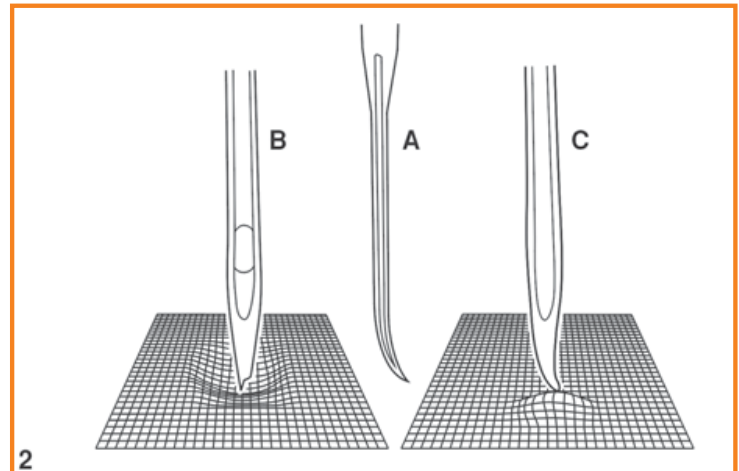
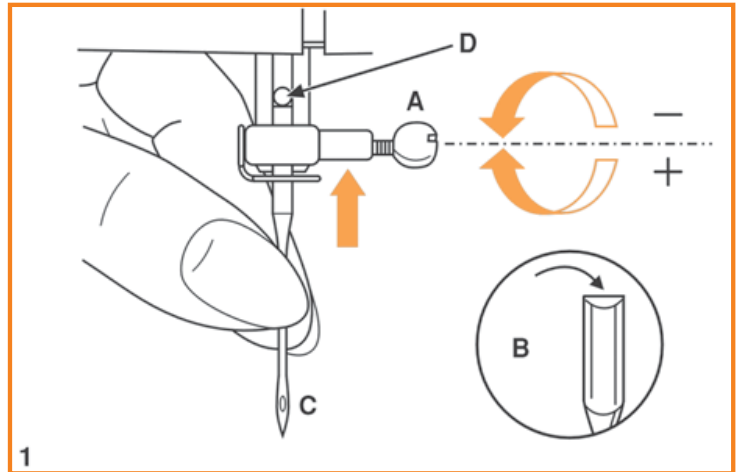

## Threading the upper thread

*This is a simple operation but it is important to carry out correctly.*

- Start by raising the needle to its highest point (1), and also raise the presser foot to open the tension discs. (2)

*Note:*

*For safety, it is strongly suggested you turn off the power before threading.*

- Lift up the spool pin. Place the spool of thread on the holder with the thread coming off the spool as shown. For small thread spools, place small side of spool cap next to spool. (3)
- Draw thread from spool through the upper thread guide. (4)
- Guide thread around thread guide (5) pulling thread through pre-tension spring as illustrated.
- Thread tension module by leading thread down right channel and up left channel (6). During this process it is helpful to hold the thread between the spool and thread guide (4).
- At the top of this movement pass thread from right to left through the slotted eye of the take-up lever and then downwards again. (7)
- Pass thread behind the flat, horizontal thread guide. (8)
- Now take thread behind the thin wire needle clamp guide and then down to the needle which should be threaded from front to back. (9)

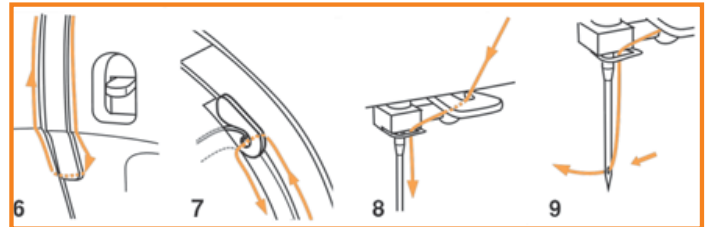
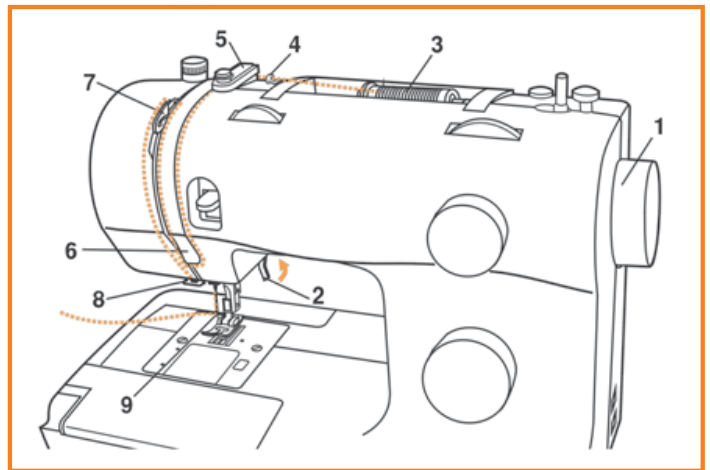
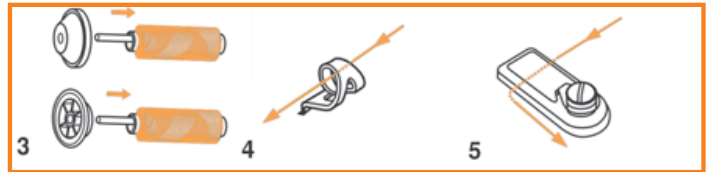

## Thread tension

### Upper thread tension

Basic thread tension setting: "4"

To increase the tension, turn the dial to the next number up.

To reduce the tension, turn the dial to the next number down.

- A. Normal thread tension for straight stitch sewing.
- B. Thread tension too loose for straight stitch sewing.  
Turn dial to higher number.
- C. Thread tension too tight for straight stitch sewing.  
Turn dial to lower number.
- D. Normal thread tension for zigzag and decorative sewing.

### Please note:

- Proper setting of tension is important to good sewing.
- There is no single tension setting appropriate for all stitch functions, thread on fabric.
- A balanced tension (identical stitches both top and bottom) is usually only desirable for straight stitch construction sewing.
- 90% of all sewing will be between "3" and "5" ("4" is basic setting).
- For zigzag and decorative sewing stitch functions, thread tension should generally be less than for straight stitch sewing.
- For all decorative sewing you will always obtain a nicer stitch and less fabric puckering when the upper thread appears on the bottom side of your fabric.

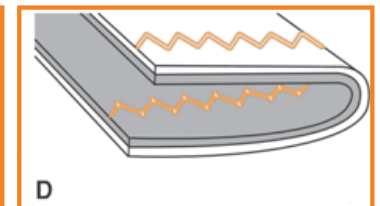
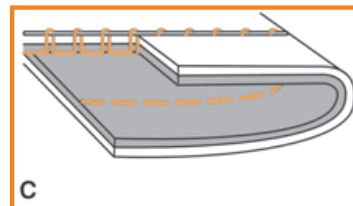
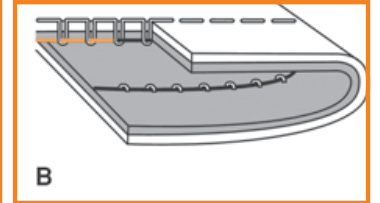
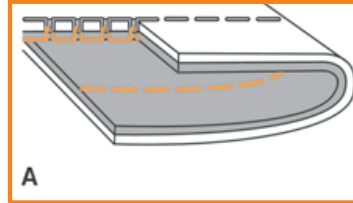
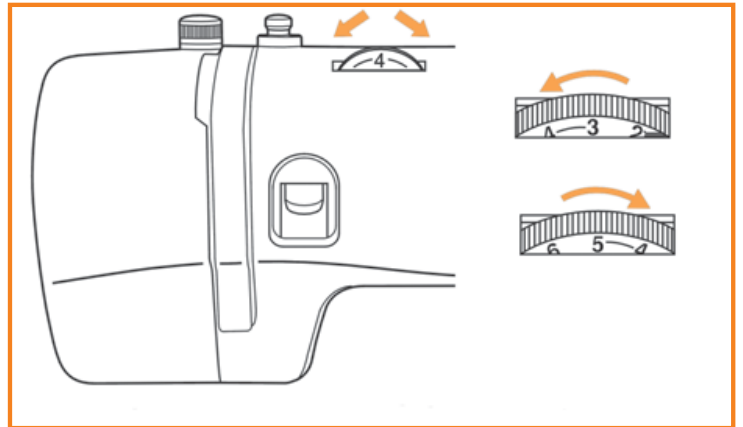

## Raising the bobbin thread

Hold the upper thread with the left hand. Turn the handwheel (1) towards you (counterclockwise) lowering, then raising needle.

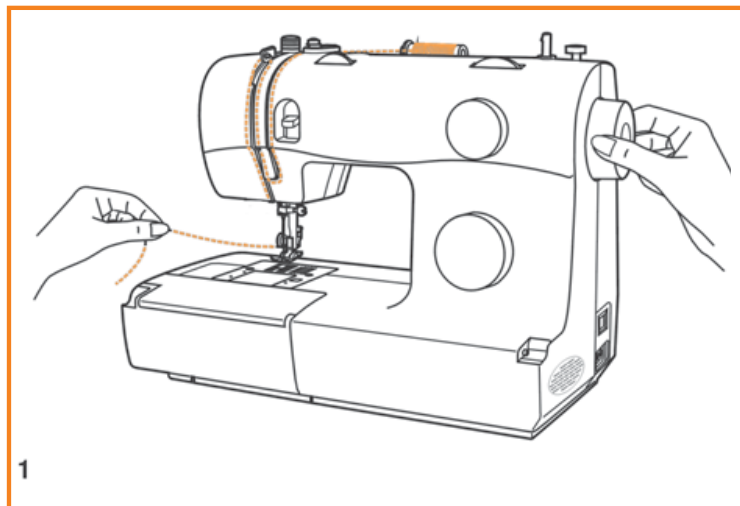

Gently pull on the upper thread to bring the bobbin thread up through the needle plate hole (2).

Lay both threads to the back under the presser foot. (3)

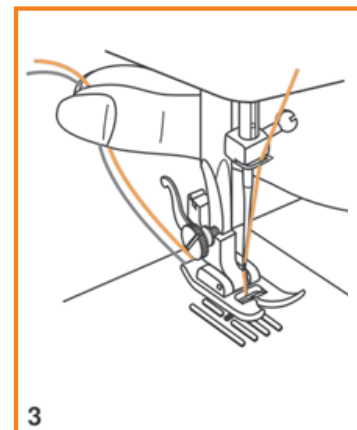
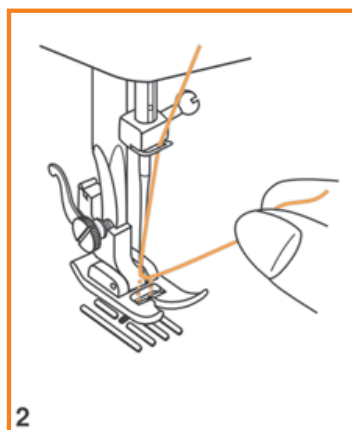

## Reverse sewing

Reverse sewing is used for locking the end of seams and where reinforcement is needed. At the end of seam, press down the reverse sewing lever and touch the foot control lightly. Sew a few reverse stitches. Release lever and the machine will sew forwards again (A/1).

## Changing sewing directions

1. Stop the machine at the point where you wish to change directions with the needle still in the fabric.
2. Raise the presser foot and turn the fabric to line up its new direction using the needle as a turning point. (2)
3. Lower the presser foot and start sewing in the new direction.

## Removing your work

Turn the handwheel towards you to bring the thread take up lever to its highest position. Raise the presser foot and draw the fabric away from you. (3)

## Cutting the thread

Hold the threads behind the presser foot with both hands, guide them to the slit (B) and press down. (4)

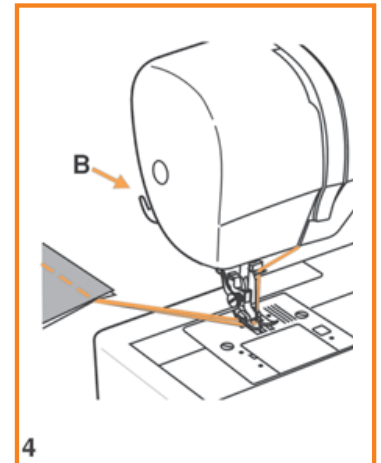
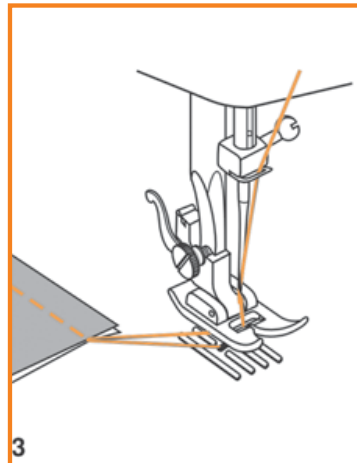
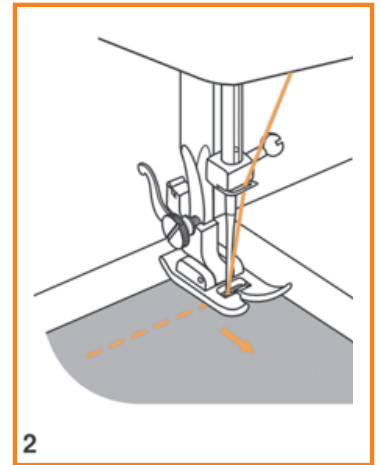
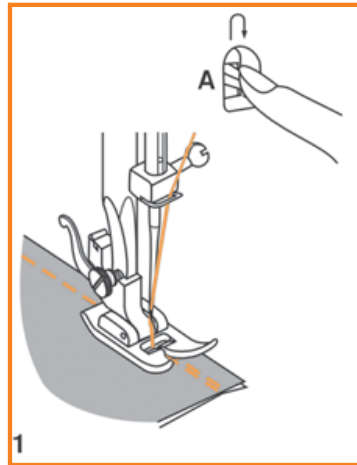

## Matching needle/ fabric/ thread

### NEEDLE, FABRIC, THREAD SELECTION GUIDE

NEEDLE SIZE	FABRICS	THREAD
9-11 (70-80)	Lightweight fabrics: thin cottons, voile, serge, silk, muslin, Qiana, interlocks, cotton knits, tricot, jerseys, crepes, woven polyester, shirt & blouse fabrics.	Light-duty thread in cotton, nylon, polyester or cotton wrapped polyester.
11-14 (80-90)	Medium weight fabrics: cotton, satin, kettlecloth, sailcloth, double knits, lightweight woollens.	Most threads sold are medium size and suitable for these fabrics and needle sizes.
14 (90)	Medium weight fabrics: cotton duck, woolen, heavier knits, terrycloth, denims.	Use polyester threads on synthetic materials and cotton on natural woven fabrics for best results. Always use the same thread on top and bottom.
16 (100)	Heavyweight fabrics: canvas, woolens, outdoor tent and quilted fabrics, denims, upholstery material (light to medium).	
18 (110)	Heavy woolens, overcoat fabrics, upholstery fabrics, some leathers and vinyls.	Heavy duty thread, carpet thread. (Use heavy foot pressure-heavy numbers.)

IMPORTANT: Match needle size to thread size and weight of fabric.

### NEEDLE, FABRIC SELECTION

NEEDLES	EXPLANATION	TYPE OF FABRIC
HA x 1 15 x 1	Standard sharp needles. Sizes range thin to large. 9 (65) to 18 (110)	Natural woven fabrics-wool, cotton, silk, etc. Qiana. Not recommended for double knits.
15 x 1/705H	Semi-ball point needle, scarfed. 9 (65) to 18 (110)	Natural and synthetic woven fabrics, polyester blends. Knits-polyesters, interlocks, tricot, single and double knits. Can be used instead of 15 x 1 for sewing all fabrics.
15 x 1/705H (SUK)	Twin Needle.	Woven fabrics and knits.
130 PCL	Leather needles. 12 (80) to 18 (110)	Leather, vinyl, upholstery. (Leaves smaller hole than standard large needle.)

- Note:
1. Twin needles, can be purchased for utility and decorative work.
  2. When sewing with twin needles, the stitch width dial should be set at less than "3".
  3. For best sewing results always use genuine needles.
  4. Replace needle often (approximately every other garment) and/ or at first thread breakage or skipped stitches.

## How to choose your stitch

To select a stitch, simply turn the stitch selection dial. The stitch selection dial may be turned in either direction. The following page shows the recommended range of stitch lengths and widths.

Adjust the stitch length with the stitch length dial. You may choose stitch width by turning the stitch width dial.

Adjust the stitch length and stitch width according to the fabric being used.

To obtain any of the other stitches shown in the upper row on the stitch selection panel, select the letter above the stitch with the stitch selection dial. Adjust the stitch length and the stitch width with the control dials according to the result desired.

To obtain any of the stitches on the second row, turn the stitch length dial to "S1" or "S2", select the stitch desired with stitch selection dial, and adjust the stitch width with the stitch width dial.

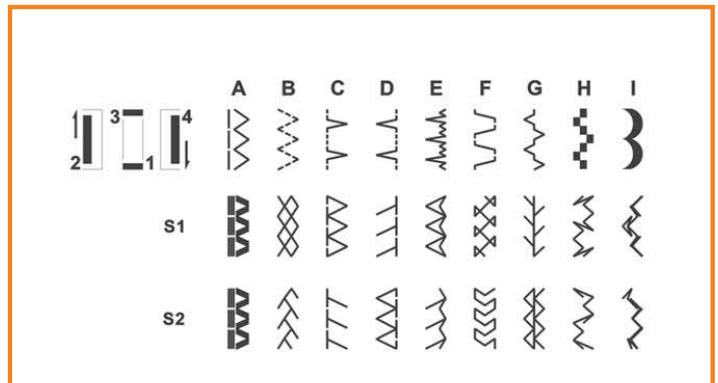
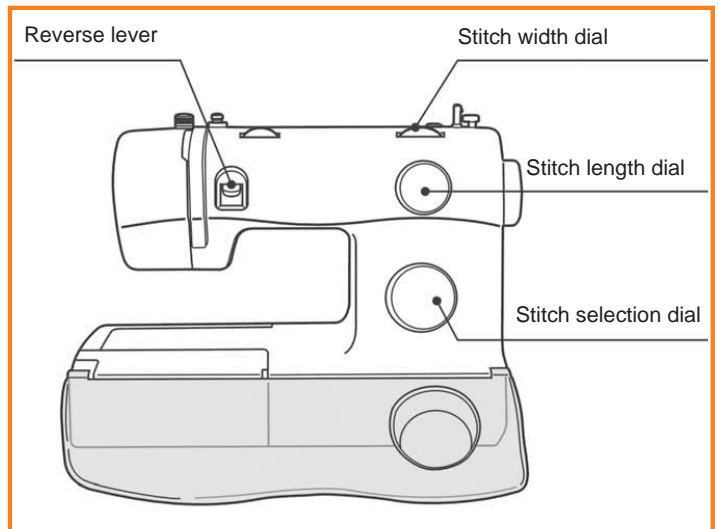

## Straight stitching

Turn the stitch selection dial so that the stitch display shows the straight stitch position.

Generally speaking, the thicker the fabric, thread and needle, the longer the stitch should be.

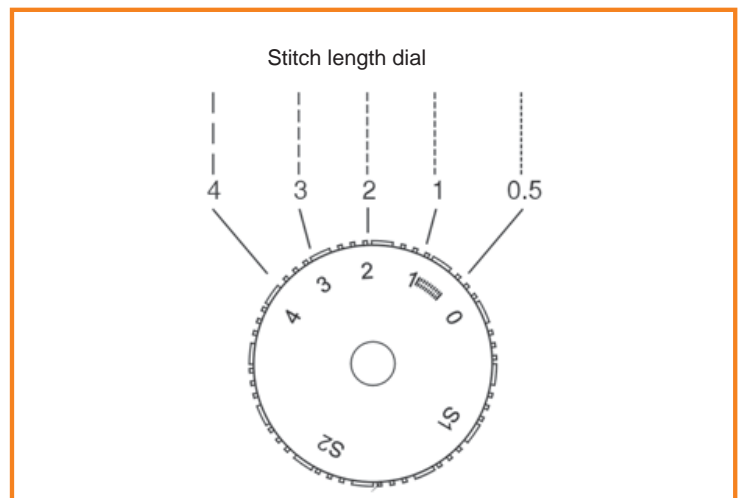
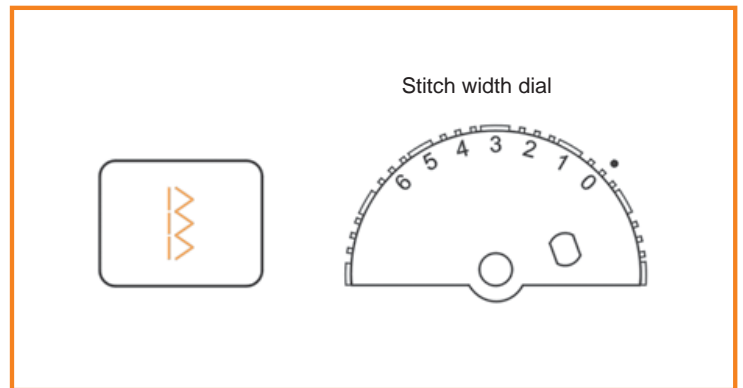



## Zigzag stitching

Turn the stitch selector dial to "A".

### Function of stitch width dial

The maximum zigzag stitch width for zigzag stitching is "6"; however, the width can be reduced on any pattern. The width increases as you move zigzag dial from "0" - "6".

For twin needle sewing, never set the width wider than "3". (1)

### Function of stitch length dial while zigzagging

The density of zigzag stitches increase as the setting of stitch length dial approaches "0".

Neat zigzag stitches are usually achieved at "2.5" or below.

Closed up zigzag stitches (close together) are referred to as a satin stitch. (2)

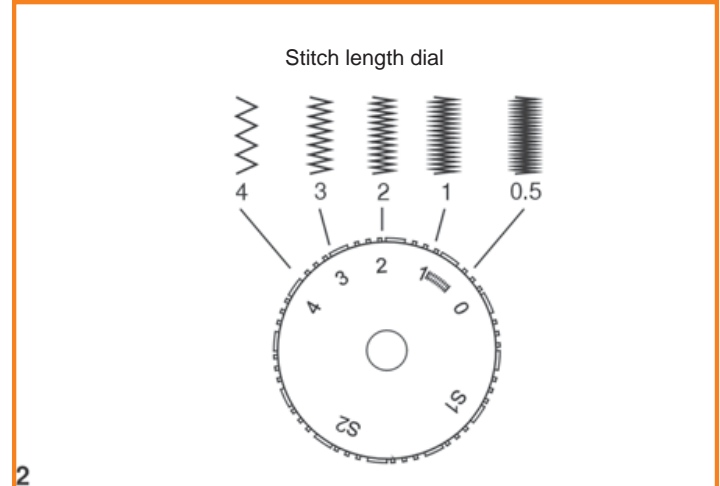
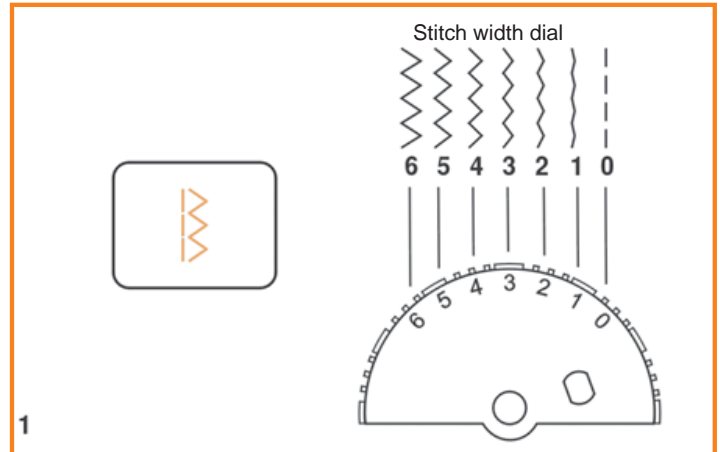

## Overcasting stitches

Seams, overcasting, visible hems.  
Turn stitch width dial to "6".

### Stretch overlock: (1)

Turn stitch length dial to "S1".  
The stitch width can be adjusted to suit the fabric.  
For fine knits, jerseys, neck edges, ribbing.

### Standard overlock: (2)

Turn stitch length dial to "S2".  
The stitch width can be adjusted to suit the fabric.  
For fine knits, jerseys, neck edges, ribbing.

All overlock stitches are suitable for sewing and neatening edges and visible seams in one operation.

When neatening, the needle should just go over the edge of the fabric.

### Attention:

*Use new needles or ball point needles or stretch needle!*

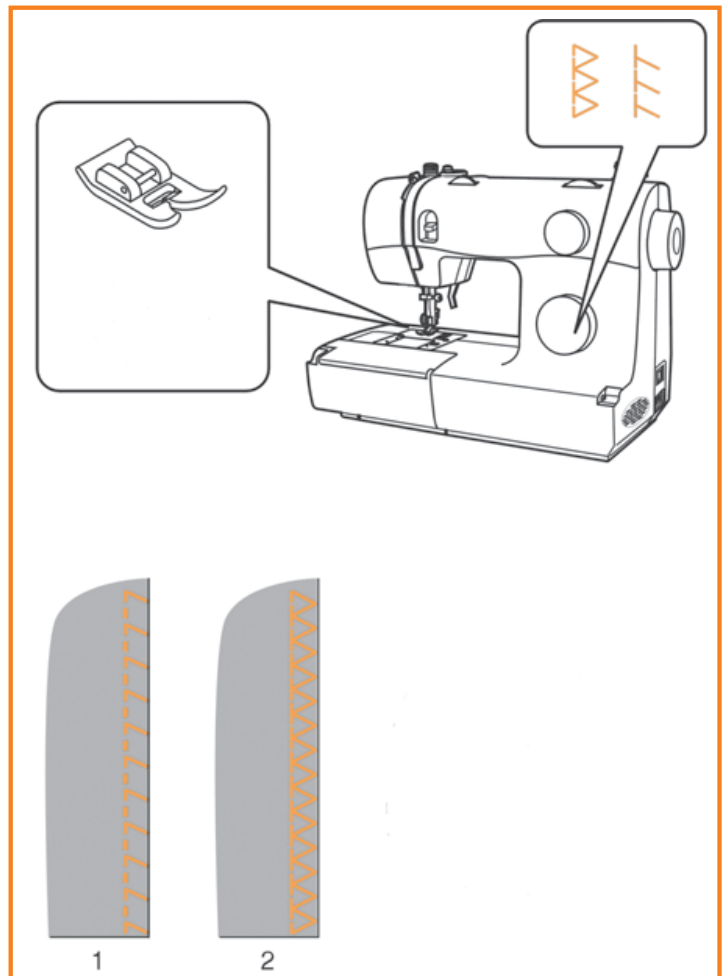

## Buttonholes

### Prepare

1. Take off the standard foot and attach the buttonhole foot.
2. Measure diameter and thickness of button and add 0.3 cm (1/8") for bar tacks; mark buttonhole size on fabric.
3. Place fabric under the foot, so that marking of the buttonhole foot aligns with marking of fabric. Lower the foot, so that the center line of the fabric buttonhole come to the center of the foot hole.

Adjust the stitch length dial in the "  " to set stitch density.

Set stitch width control between "4" - "6".

*Note: density varies according to the fabric. Always sew a test buttonhole.*

Follow the 4-step sequence changing from one step to another with the stitch pattern selector dial. Take care not to sew too many stitches in stages 1 and 3. Cut buttonhole open from both ends towards the middle.

### Tips:

- Slightly reduce upper thread tension produce better results.
- Use a backing for fine or stretchy fabrics.
- It is advisable to use heavy thread or cord for stretch or knit fabrics.
- The zigzag should sew over the heavy thread or cord.

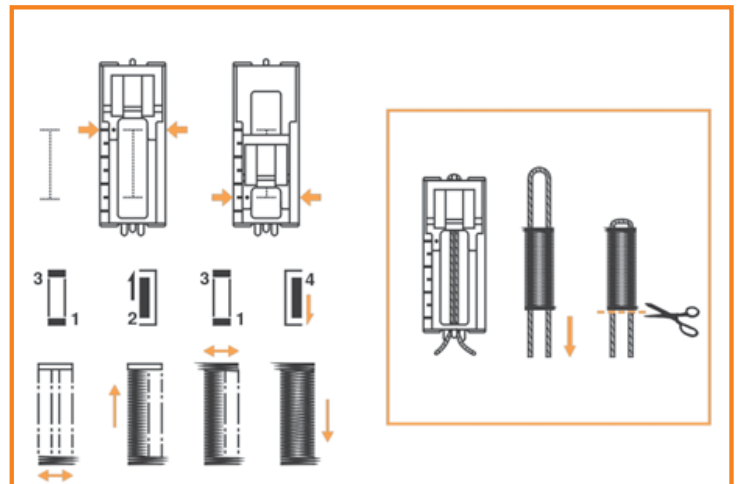
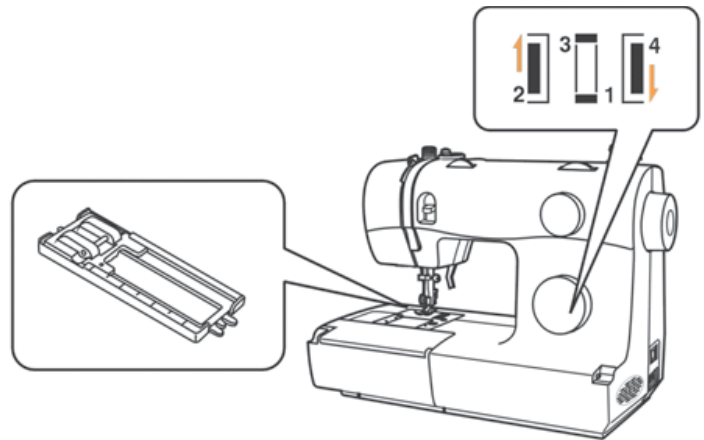

## Zippers and piping

Set the pattern selector dial to " ".

Turn stitch width dial to "0".

Set stitch length control between "1" - "4".

Change to zipper foot (1).

The zipper foot can be attached right (2) or left (3) depending on which side of the foot you are going to sew.

To sew past the zipper pull, lower the needle into the fabric, raise the presser foot and push the zipper pull behind the presser foot. Lower the foot and continue to sew.

It is also possible to sew in a length of cord, into a bias strip to form a welt (4).

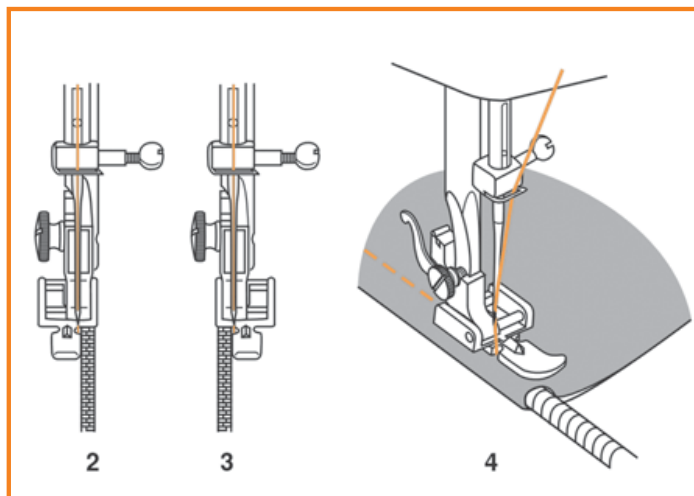
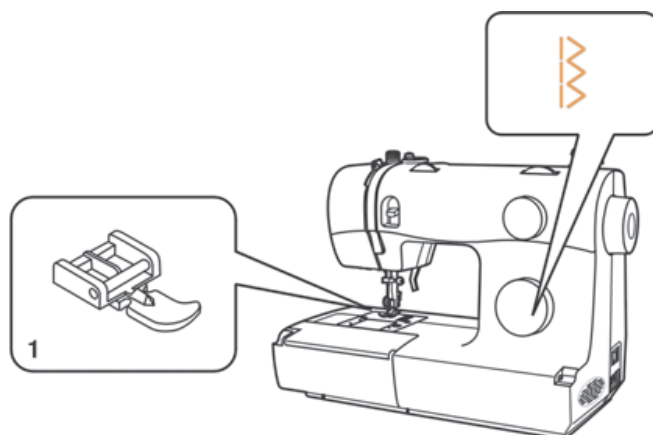

### 3-step zigzag stitch

Sewing on lace and elastic, darning, mending, reinforcing edges.

Set the machine as illustrated.

Set stitch width control between "4" - "6".

Set stitch length control between "1" - "2".

Place the patch in position. The stitch length can be shortened to produce very close stitches. (1)

When mending tears, it is advisable to use a piece of backing fabric to reinforce. The stitch density can be varied by adjusting the stitch length. First sew over the center and then overlap on both sides.

Depending on the type of fabric and damage, sew between 3 and 5 rows. (2)

#### Sewing elastic

- Place the elastic on the fabric.
- As you sew, stretch the elastic both in the front and behind the presser foot as shown in fig. (3).

#### Joining fabric

The elastic stitch can be used to join two pieces of fabric together and is very effective when sewing knitted fabrics. If nylon thread is used, the stitch will not be visible.

- Place the edges of the two pieces of fabric together and center them under the presser foot.
- Sew them together using the elastic stitch taking care to keep the two fabric edges close together as shown in fig. (4).

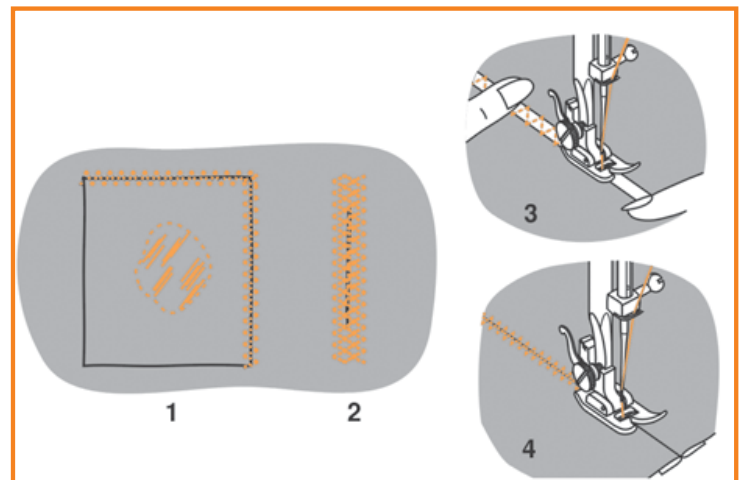
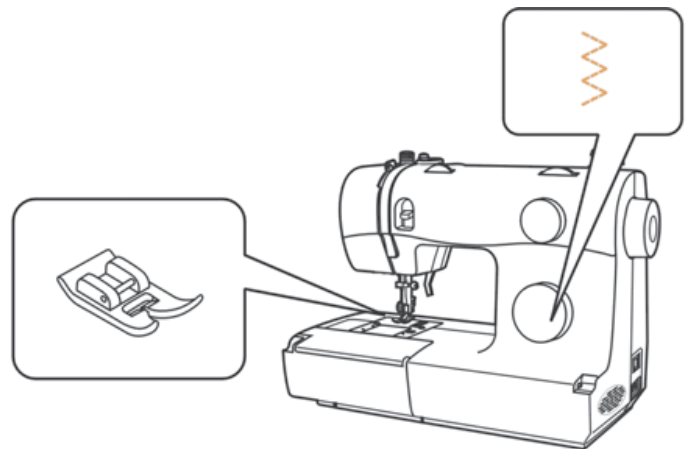

## **Straight stretch stitch and Stretch triple zigzag stitch**

### **Straight stretch stitch**

Set the stitch pattern dial to "A".

Used to add triple reinforcement to stretch and hardwearing seams.

Set the stitch length dial to "S1".

Set the stitch width dial to "0".

### **Stretch triple zigzag stitch**

Set the stitch pattern dial to "A".

Used primarily as a decorative stitch.

Set the stitch length dial to "S1".

Adjust the stitch width dial to between "4" and "6".

Stretch triple zigzag stitch is suitable for firm fabrics like denim, poplin, duck, etc.

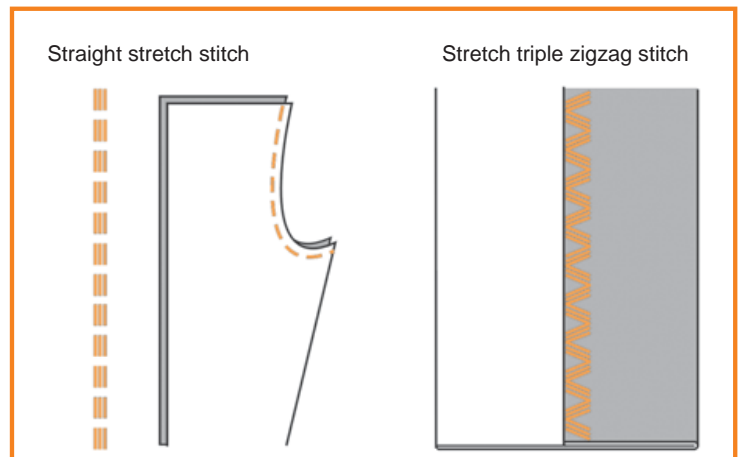
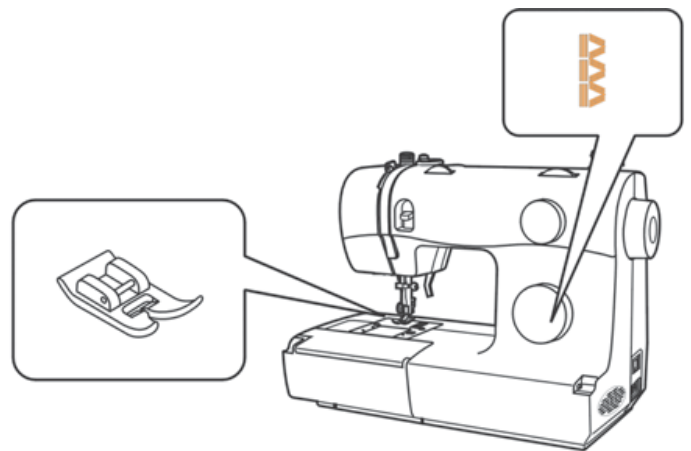

## Free-motion darning

Install the feed dog cover. (1)  
Set the stitch length dial to "0".  
Set the stitch width dial to "0".

Remove the presser foot clamp. (2)

Attach the free-motion/darning foot to the presser foot holder. The lever (A) should be behind the needle clamp screw (B). Press the free-motion foot on firmly from behind with your index finger and tighten the screw (C). (3)

For darning, first sew around the edge of the hole (to secure the threads). (4)

First row: Always work from left to right. Turn work by 1/4 and oversew.

A darning hoop is recommended for easier sewing and better results.

### Note:

*Free-motion darning is accomplished without the sewing machine internal feed system. Movement of the fabric is controlled by the operator. It is necessary to coordinate sewing speed and movement of fabric.*

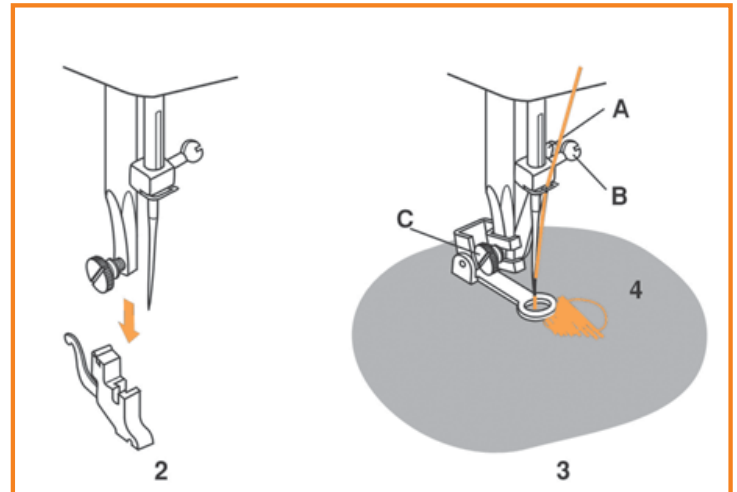
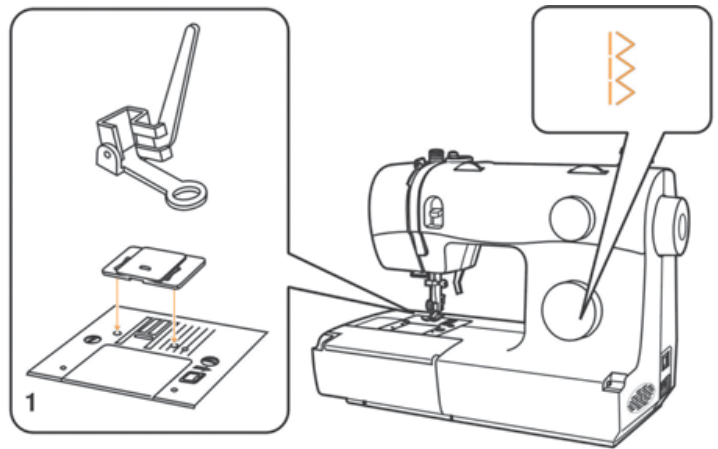

## Darning

---

- Set the machine as illustrated.
- Turn stitch width dial to "0".
- Turn stitch length dial to the desired length.
- Position the fabric to be darned under the presser foot together with the under laying fabric to be used.
- Lower the presser foot and alternately sew forward or reverse using the lever.
- Repeat this motion until the area to be darned is filled with rows of stitching.

For reverse sewing instructions, see page 17.

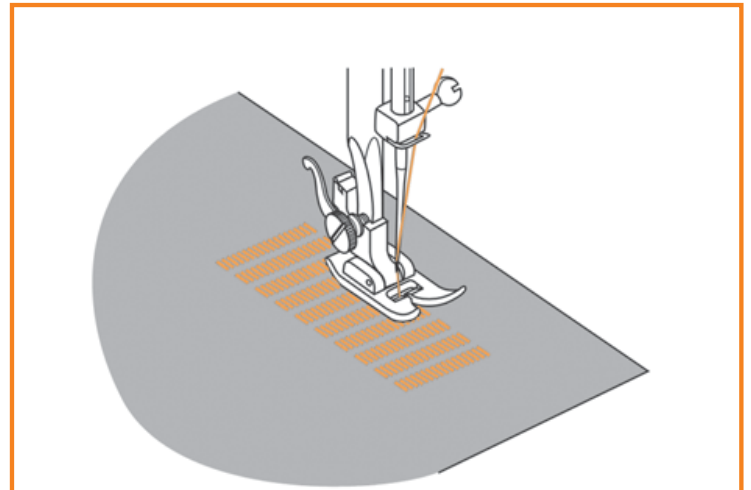
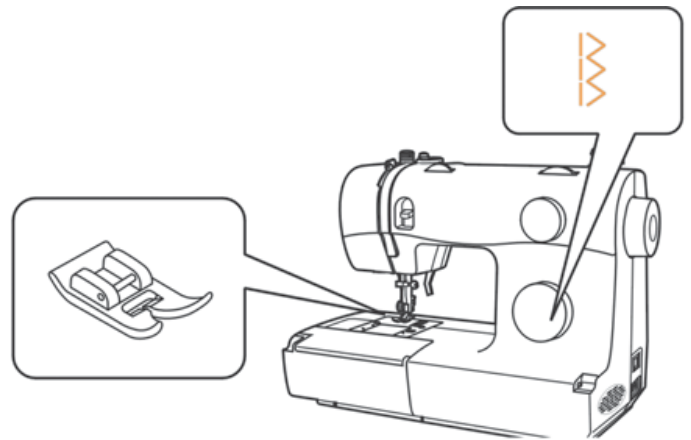



## Free-motion monogramming and embroidering

- Set the machine as illustrated.
- Turn stitch width dial to "0".
- Remove the presser foot and the presser foot holder.
- Attach the feed dog cover. (1)
- Lower presser foot lever before starting to sew.
- Adjust the stitch width according to the size of lettering or design.

### Preparation for Monogramming and Embroidering\*

- Draw the desired lettering or design on the right side of the fabric.
- Stretch the fabric between embroidery hoop as firmly as possible.
- Place the fabric under the needle. Make sure the presser foot bar is down in its lowest position.
- Turn the balance wheel towards you to bring up the lower thread through the fabric. Sew a few securing stitches at the starting point.
- Hold the hoop with thumb and forefingers of both hands while pressing the material with the middle and third fingers and supporting the outside of hoop with smaller finger.

\* Embroidery hoop not included with machine.

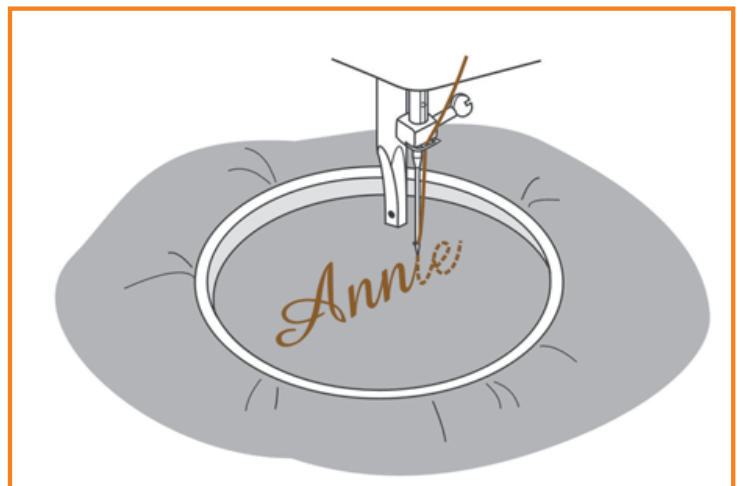
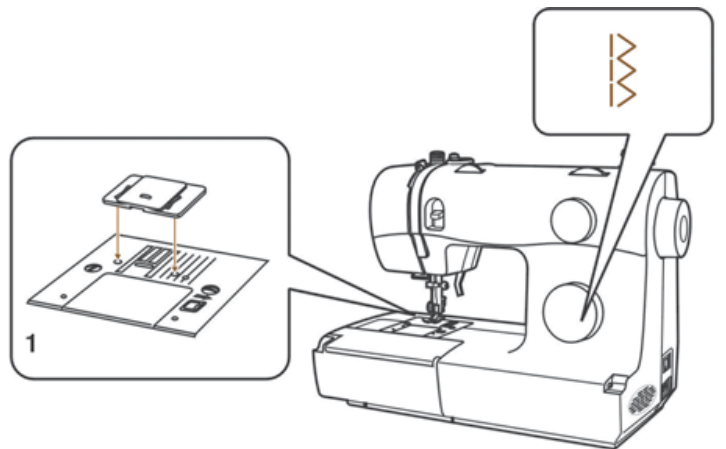

## Quilting

---

Set stitch selector as illustrated.

Turn stitch width dial to "0".

Turn stitch length dial to the desired length.

Insert the quilting guide in presser foot holder and set the space as you desired. Use the quilting foot.

Move the fabric over and sew successive rows with the guide riding along on the previous row of stitching.

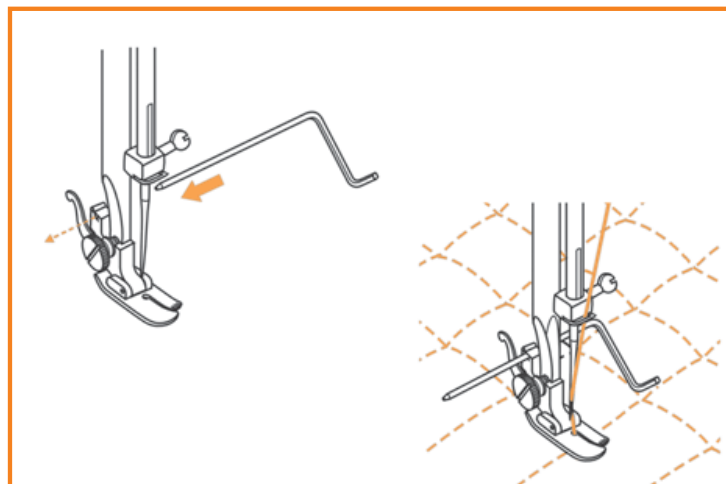
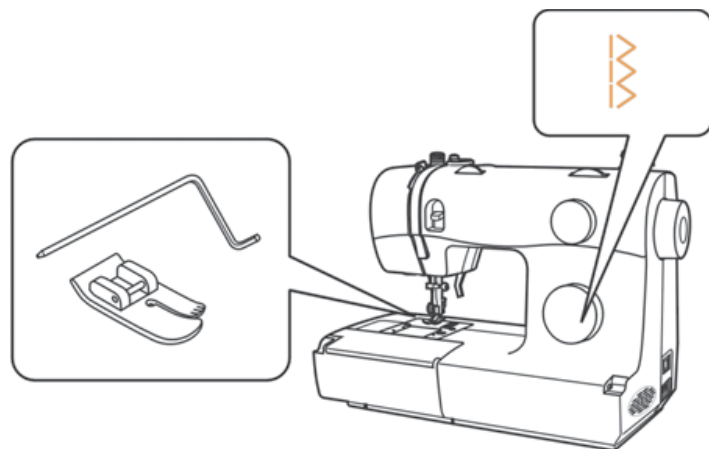

## Twin needle (Optional)

- Turn stitch width dial to "0".
- Turn stitch length dial to the desired stitch length.
- Turn stitch selector to straight stitch, center needle position.
- For twin needle sewing, insert the extra spool pin (included with the accessories) into the hole on top of the machine.
- Make sure that the two threads used to thread the twin needle are of the same weight. You can use one or two colors.
- Insert the twin needle in the same way as single needle. Flat side of needle should face away from you.
- Follow instructions for single needle threading. Thread each needle separately.

### *Please Note:*

*When sewing with twin needle, always proceed slowly, and make sure to maintain a low speed to insure quality stitching.*

*When using twin needle on zigzag make sure the stitch width dial is set between "1" and "3". Do not use twin needle at setting above "3".*

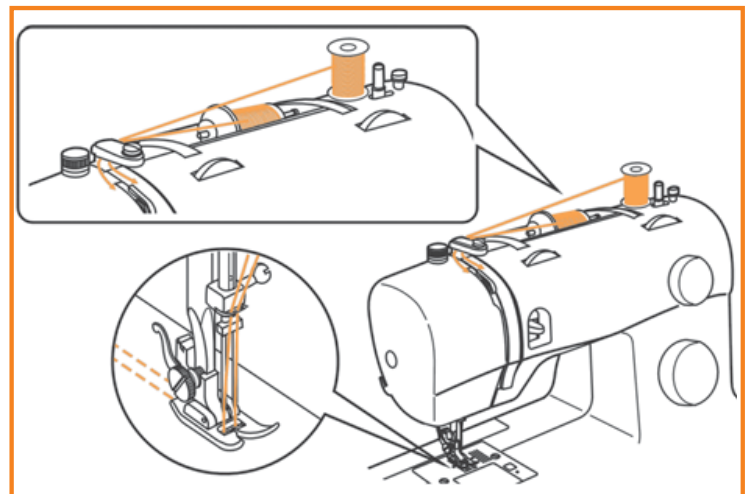
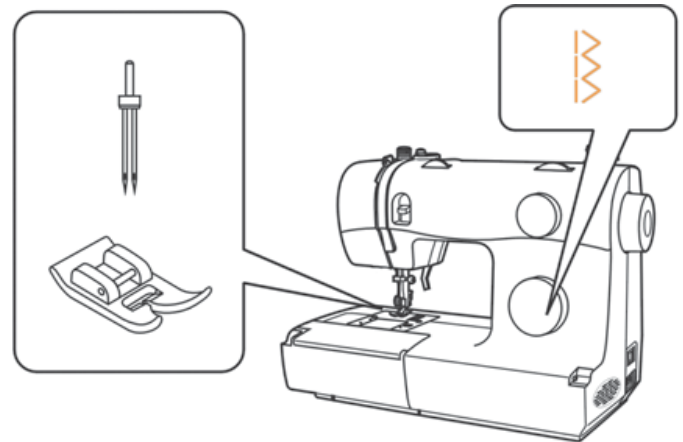

## Maintenance

### Attention:

Disconnect the machine from the wall outlet before carrying out any maintenance or changing the sewing light bulb.

### Cleaning

If lint and bits of thread accumulate in the hook, this will interfere with the smooth operation of the machine. Check regularly and clean the stitching mechanism when necessary.

#### A. Bobbin holder

1. Remove the bobbin cover plate and bobbin.
2. Clean the bobbin holder with a brush.

#### B. Hook race and feed dog

1. Remove the needle, presser foot and holder.  
Remove the bobbin cover plate and bobbin.  
Remove the screw holding the needle plate and remove the needle plate.
2. Lift up bobbin case and remove it.
3. Clean the hook race, feed dog and bobbin case with a brush. Also clean them, using a soft, dry cloth.
4. Replace the bobbin case into the hook race so that the tip (a) fits to the stopper (b) as shown.

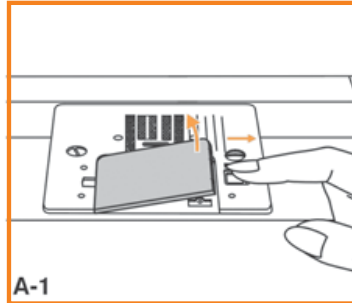

A-1

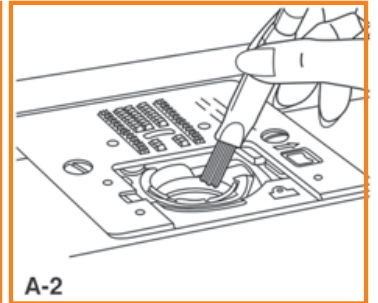

A-2

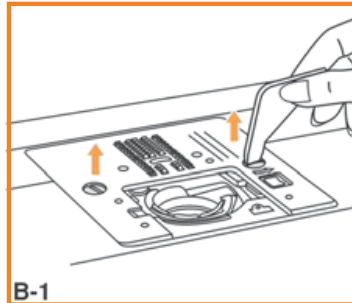

B-1

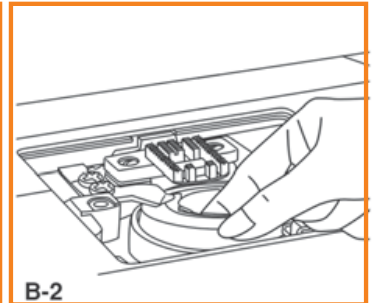

B-2

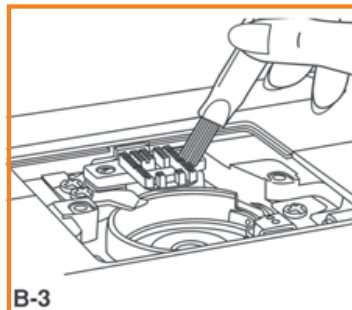

B-3

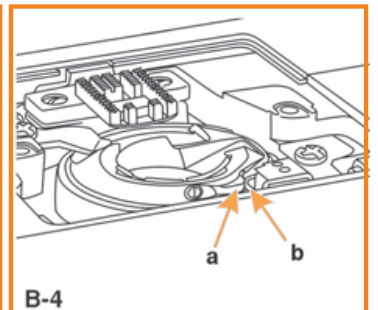

B-4

## Troubleshooting guide

Problem	Cause	Correction
Upper thread breaks	<ol style="list-style-type: none"> <li>1.The machine is not threaded correctly.</li> <li>2.The thread tension is too tight.</li> <li>3.The thread is too thick for the needle.</li> <li>4.The needle is not inserted correctly.</li> <li>5.The thread is wound around the spool holder pin.</li> <li>6.The needle is damaged.</li> </ol>	<ol style="list-style-type: none"> <li>1.Rethread the machine.</li> <li>2.Reduce the thread tension. (lower number)</li> <li>3.Select a larger needle.</li> <li>4.Remove and reinsert the needle. (flat side towards the back)</li> <li>5.Remove the spool and thread from the spool holder pin.</li> <li>6.Replace the needle.</li> </ol>
Lower thread breaks	<ol style="list-style-type: none"> <li>1.The bobbin case is not inserted correctly.</li> <li>2.The bobbin case is threaded wrong.</li> <li>3.The lower thread tension is too tight.</li> </ol>	<ol style="list-style-type: none"> <li>1.Remove and reinsert the bobbin case and pull on the thread. The thread should pull easily.</li> <li>2.Check both bobbin and bobbin case.</li> <li>3.Loosen lower thread tension as described.</li> </ol>
Skipped stitches	<ol style="list-style-type: none"> <li>1.The needle is not inserted correctly.</li> <li>2.The needle is damaged.</li> <li>3.The wrong size needle has been used.</li> <li>4.The foot is not attached correctly.</li> </ol>	<ol style="list-style-type: none"> <li>1.Remove and reinsert needle. (flat side towards the back)</li> <li>2.Insert a new needle.</li> <li>3.Choose a needle to suit the thread and fabric.</li> <li>4.Check and attach correctly.</li> </ol>
Needle breaks	<ol style="list-style-type: none"> <li>1.The needle is damaged.</li> <li>2.The needle is not correctly inserted.</li> <li>3.Wrong needle size for the fabric.</li> <li>4.The wrong foot is attached.</li> </ol>	<ol style="list-style-type: none"> <li>1.Insert a new needle.</li> <li>2.Insert the needle correctly. (flat side towards the back)</li> <li>3.Choose a needle to suit the thread and fabric.</li> <li>4.Select the correct foot.</li> </ol>
Loose stitches	<ol style="list-style-type: none"> <li>1.The machine is not correctly threaded.</li> <li>2.The bobbin case is not correctly threaded.</li> <li>3.Needle/ fabric/ thread combination is wrong.</li> <li>4.Thread tension wrong.</li> </ol>	<ol style="list-style-type: none"> <li>1.Check the threading.</li> <li>2.Thread the bobbin case as illustrated.</li> <li>3.The needle size must suit the fabric and thread.</li> <li>4.Correct the thread tension.</li> </ol>
Seams gather or pucker	<ol style="list-style-type: none"> <li>1.The needle is too thick for the fabric.</li> <li>2.The stitch length is wrong adjusted.</li> <li>3.The thread tension is too tight.</li> </ol>	<ol style="list-style-type: none"> <li>1.Select a finer needle.</li> <li>2.Readjust the stitch length.</li> <li>3.Loosen the thread tension.</li> </ol>
Uneven stitches, uneven feed	<ol style="list-style-type: none"> <li>1.Poor quality thread.</li> <li>2.The bobbin case is wrong threaded.</li> <li>3.Fabric has been pulled.</li> </ol>	<ol style="list-style-type: none"> <li>1.Select a better quality thread.</li> <li>2.Remove bobbin case, thread and insert correctly.</li> <li>3.Do not pull on the fabric while sewing, let it be taken up by the machine.</li> </ol>
The machine is noisy	<ol style="list-style-type: none"> <li>1.Fluff or oil have collected on the hook or needle bar.</li> <li>2.The needle is damaged.</li> </ol>	<ol style="list-style-type: none"> <li>1.Clean the hook and feed dog as described.</li> <li>2.Replace the needle</li> </ol>
The machine jams	Thread is caught in the hook.	Remove the upper thread and bobbin case, turn the handwheel backwards and forwards by hand and remove the thread remands.

[www.promelectroavtomat.ru](http://www.promelectroavtomat.ru)



Please note that on disposal, this product must be safely recycled in accordance with relevant National legislation relating to electrical/electronic products. If in doubt please contact your retailer for guidance



VSM Group AB • SE-561 84 Huskvarna • SWEDEN  
www.pfaff.com

412 97 76-288 • English • Inhouse production • © 2005 VSM Group AB • All statements valid at time of printing • Printed in China on environmental-friendly paper •

[www.promelectroavtomat.ru](http://www.promelectroavtomat.ru)