

**1525**  
**1525-S**

INSTRUCTION MANUAL

**1525-G**  
**1526**

This instruction manual applies to machines from the following serial numbers onwards:

# 2 722 168 →



This Instruction Manual is valid for all models and subclasses listed in the chapter "**Specifications**".



The adjustment manual for the machines can be downloaded free of charge from the internet address

**[www.pfaff-industrial.com/pfaff/de/service/downloads](http://www.pfaff-industrial.com/pfaff/de/service/downloads)**

As an alternative to the internet download the adjustment manual can also be ordered in book form under part no. **296-12-18 597/002**.

The reprinting, copying or translation of PFAFF Instruction Manuals, whether in whole or in part, is only permitted with our previous authorization and with written reference to the source.

**PFAFF Industriesysteme  
und Maschinen AG**

Hans-Geiger-Str. 12 - IG Nord  
D-67661 Kaiserslautern

|          | Contents .....   | Chapter - Page |
|----------|--|----------------|
| <b>1</b> | <b>Safety .....</b>  | <b>1 - 1</b>   |
| 1.01     | Regulations .....  | 1 - 1          |
| 1.02     | General notes on safety .....                                  | 1 - 1          |
| 1.03     | Safety symbols .....   | 1 - 2          |
| 1.04     | Important notes for the user .....                             | 1 - 2          |
| 1.05     | Notes for operating and technical staff .....                  | 1 - 3          |
| 1.05.01  | Operating staff .....  | 1 - 3          |
| 1.05.02  | Technical staff .....  | 1 - 3          |
| 1.06     | Danger warnings .....  | 1 - 4          |
| <b>2</b> | <b>Proper use .....</b>  | <b>2 - 1</b>   |
| <b>3</b> | <b>Specifications .....</b>                                    | <b>3 - 1</b>   |
| 3.01     | PFAFF 1525, PFAFF 1526 .....                                   | 3 - 1          |
| 3.02     | Possible work aids .....                                       | 3 - 2          |
| <b>4</b> | <b>Machine disposal .....</b>                                  | <b>4 - 1</b>   |
| <b>5</b> | <b>Transportation, packing and storage .....</b>               | <b>5 - 1</b>   |
| 5.01     | Transportation to customer's premises .....                    | 5 - 1          |
| 5.02     | Transportation inside customer's premises .....                | 5 - 1          |
| 5.03     | Disposal of packing materials .....                            | 5 - 1          |
| 5.04     | Storage .....  | 5 - 1          |
| <b>6</b> | <b>Explanation of symbols .....</b>                            | <b>6 - 1</b>   |
| <b>7</b> | <b>Controls .....</b>  | <b>7 - 1</b>   |
| 7.01     | On/off switch .....  | 7 - 1          |
| 7.02     | Keys on machine head .....                                     | 7 - 1          |
| 7.03     | Pedal .....  | 7 - 2          |
| 7.04     | Knee switch .....  | 7 - 2          |
| 7.05     | Presser foot fixing key .....                                  | 7 - 3          |
| 7.06     | Adjusting the stitch length (on the PFAFF 1525 and 1526) ..... | 7 - 3          |
| 7.07     | Adjusting the stitch length (on the PFAFF 1525-S) .....        | 7 - 4          |
| 7.08     | Reverse-feed control .....                                     | 7 - 4          |
| 7.09     | Edge trimmer -731/02 .....                                     | 7 - 5          |

---

---

# Contents

---

|           | Contents .....   | Chapter - Page |
|-----------|--|----------------|
| 7.10      | Secondary needle-thread tension .....                                      | 7 - 5          |
| 7.11      | Adjusting the top feed stroke .....  | 7 - 6          |
| 7.12      | Bobbin-thread supply monitor -926/06 .....                                 | 7 - 6          |
| 7.13      | Bobbin thread control by stitch counting .....                             | 7 - 7          |
| 7.14      | Control panel (only on machines with Quick-Eco drive) .....                | 7 - 7          |
| <b>8</b>  | <b>Installation and commissioning .....</b>                                | <b>8 - 1</b>   |
| 8.01      | Installation .....   | 8 - 1          |
| 8.01.01   | Adjusting the table-top height .....                                       | 8 - 1          |
| 8.01.02   | Assembling the motor (only on machines with Quick-motor) .....             | 8 - 2          |
| 8.01.03   | Tightening the V-belt .....  | 8 - 2          |
| 8.01.04   | Mounting the bottom V-belt guard .....                                     | 8 - 3          |
| 8.01.05   | Fitting the bottom V-belt guard .....                                      | 8 - 3          |
| 8.01.06   | Fitting the synchronizer .....   | 8 - 4          |
| 8.01.07   | Fitting the tilt lock .....  | 8 - 4          |
| 8.01.08   | Fitting the reel stand .....   | 8 - 5          |
| 8.02      | Connecting the plug-in connections and earth cables .....                  | 8 - 6          |
| 8.03      | Installation .....   | 8 - 7          |
| 8.04      | Switching the machine on/off .....   | 8 - 8          |
| 8.05      | Basic position of the machine drive unit .....                             | 8 - 8          |
| 8.05.01   | On machines with Quick-EcoDrive and control unit P70ED .....               | 8 - 8          |
| 8.05.02   | On machines with Quick-PicoDrive and control unit P41 PD-L .....           | 8 - 8          |
| <b>9</b>  | <b>Setting up .....</b>  | <b>9 - 1</b>   |
| 9.01      | Inserting the needle .....   | 9 - 1          |
| 9.02      | Winding the bobbin thread, regulating the winder tension .....             | 9 - 2          |
| 9.03      | Bobbin-changing/threading, and regulating the bobbin thread tension .....  | 9 - 3          |
| 9.04      | Threading needle thread and regulating its tension on the PFAFF 1525 ..... | 9 - 4          |
| 9.05      | Threading needle threads and regulating tensions on the PFAFF 1526 .....   | 9 - 5          |
| <b>10</b> | <b>Care and maintenance .....</b>  | <b>10 - 1</b>  |
| 10.01     | Cleaning the hook area .....   | 10 - 1         |
| 10.02     | Oiling the hook .....  | 10 - 2         |
| 10.03     | Checking/adjusting the air pressure .....                                  | 10 - 3         |
| 10.04     | Cleaning the air filter of the air-filter/lubricator .....                 | 10 - 3         |

---

|           |   |                |
|-----------|---|----------------|
|           | Contents .....  | Chapter - Page |
| 10.05     | Parameter settings .....  | 10 - 4         |
| 10.05.01  | Parameter list .....  | 10 - 4         |
| <b>11</b> | <b>Mounting the table top and Circuit diagrams .....</b>                      | <b>11 - 1</b>  |
| 11.01     | Table top cutout .....  | 11 - 1         |
| 11.02     | Mounting the table top (with Quick-EcoDrive and control unit P 70 EDx) .....  | 11 - 2         |
| 11.03     | Mounting the table top (with Quick-PicoDrive and control unit P41 PD-L) ..... | 11 - 3         |
| 11.04     | Circuit diagrams (with Quick-EcoDrive and control unit P 70 EDx) .....        | 11 - 4         |
| 11.05     | Block diagram PFAFF 1525 S with control unit P41 PD-L .....                   | 11 - 10        |
| 11.06     | Circuit diagrams (with Quick-PiccoDrive and control unit P41 PD-L) .....      | 11 - 11        |
| <b>12</b> | <b>Wearing parts .....</b>  | <b>12 - 1</b>  |

---

## 1 Safety

### 1.01 Regulations

This machine is constructed in accordance with the European regulations indicated in the conformity and manufacturer's declarations.

In addition to this instruction manual, please also observe all generally accepted, statutory and other legal requirements, including those of the user's country, and the applicable pollution control regulations!

The valid regulations of the regional social insurance society for occupational accidents or other supervisory authorities are to be strictly adhered to!

### 1.02 General notes on safety

- The machine must only be operated by adequately trained operators and only when the instruction manual has been fully read and understood!
- All notices on safety and the instruction manual of the motor manufacturer are to be read before the machine is put into operation!
- All notes on the machine concerning danger and safety must be observed!
- The machine must be used for the purpose for which it is intended and must not be operated without its safety devices; all regulations relevant to safety must be adhered to.
- When part sets are changed (e.g. needle, presser foot, needle plate, feed dog or bob-bin), during threading, when the workplace is left unattended and during maintenance work, the machine must be isolated from the power supply by turning off the on/off switch or removing the plug from the mains!
- Daily maintenance work must only be carried out by appropriately trained persons!
- Repairs and special maintenance work must only be carried out by qualified technical staff or persons with appropriate training!
- During maintenance or repairs on the pneumatic system the machine must be isolated from the compressed air supply! The only exception to this is when adjustments or function checks are carried out by appropriately trained technical staff!
- Work on the electrical equipment must only be carried out by technical staff who are qualified to do so!
- Work on parts or equipment connected to the power supply is not permitted! The only exceptions to this are specified in regulations EN 50110.
- Conversion or modification of the machine must only be carried out under observation of all relevant safety regulations!

- Only spare parts which have been approved by us are to be used for repairs! We draw special attention to the fact that spare parts and accessories not supplied by us have not been subjected to testing nor approval by us. Fitting and/or use of any such parts may cause negative changes to the design characteristics of the machine. We shall not accept any liability for damage caused by the use of non-original parts.

## 1.03 Safety symbols



Danger!  
Special points to observe.



Danger of injury to operating or technical staff!



### Caution

Do not operate without finger guard and safety devices. Before threading, changing bobbin and needle, cleaning etc. switch off main switch.

## 1.04 Important notes for the user

- This instruction manual belongs to the equipment of the machine and must be available to the operating staff at all times.  
This instruction manual must be read before the machine is operated for the first time.
- Both operating and technical staff must be instructed on the safety devices of the machine and on safe working methods.
- It is the duty of the user to operate the machine in perfect running order only.
- The user must ensure that none of the safety devices are removed nor put out of working order.
- The user must ensure that only authorized persons operate and work on the machine.

For further information please refer to your PFAFF agency.

## 1.05 Notes for operating and technical staff

### 1.05.01 Operating staff

Operating staff are the persons responsible for setting up, operating and cleaning the machine and for removing any disturbances in the sewing area.

The operating staff are obliged to observe the following points, and must:

- always observe the notes on safety in this instruction manual!
- avoid using any working methods which adversely effect the safety of the machine!
- avoid wearing loose-fitting clothing or jewelry such as necklaces or rings!
- also ensure that only authorized persons are allowed near the danger area of the machine!
- immediately report to the user any changes to the machine that may affect its safety!

### 1.05.02 Technical staff

Technical staff are persons who have been trained in electrical engineering, electronics, pneumatics and mechanical engineering. They are responsible for lubricating, servicing, repairing and adjusting the machine.

The technical staff are obliged to observe the following points, and must:

- always observe the notes on safety in this instruction manual!
- switch off the on/off switch before carrying out adjustment and repair work and ensure it cannot be switched on again unintentionally!
- never work on parts or equipment still connected to the power supply! Exceptions to this are only permissible according to regulations EN 50110;
- isolate the machine from the compressed air supply when carrying out maintenance or repair work on pneumatic equipment!  
Exceptions to this are only permissible for function checks;
- replace all safety covers after carrying out maintenance or repair work!



1.06

Danger warnings



A working area of 1 m must be kept free both in front of and behind the machine, so that easy access is possible at all times.



Never put your hands in the sewing area during sewing!  
Danger of injury by the needle!



While setting or adjusting the machine do not leave any objects on the table nor in the needle plate area! Objects may be trapped or slung out of the machine!

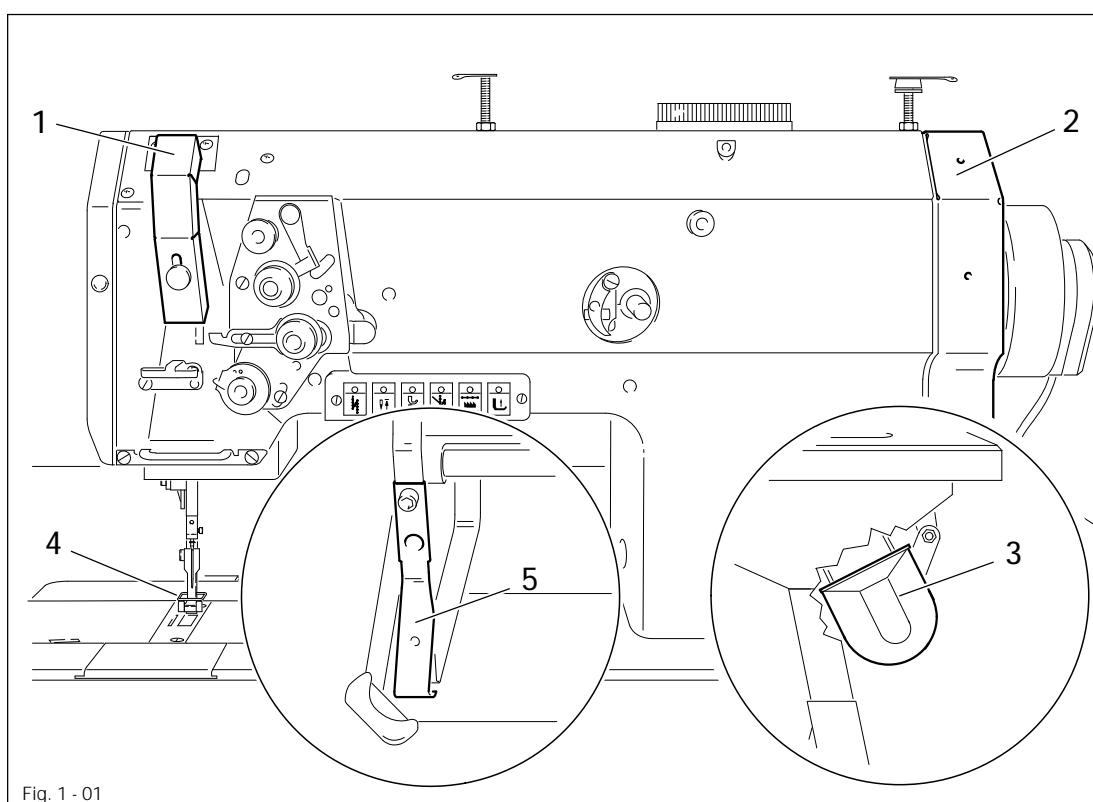

Fig. 1 - 01



Do not operate the machine without take-up lever guard 1!  
Danger of injury due to movement of the take-up lever!



Do not operate the machine without belt guards 2 und 3!  
Dange of injury by the rotating v-belt!



Do not operate the macine without finger guard 4!  
Danger of injury by the needle!



Do not operate the machine without tilt lock 5!  
Danger of crushing between sewing head and table!

### 2

#### Proper use

The **PFAFF 1525** and **PFAFF 1525-S** are single needle, special high-speed lockstitch sewing machines with unison feed and a large hook.

The **PFAFF 1525-G** is a single needle, special high-speed lockstitch sewing machines with unison feed and an extra large hook.

The **PFAFF 1526** is a two-needle, special high-speed lockstitch sewing machines with unison feed and a large hook.

Die Maschinen dienen zur Herstellung von Doppelsteppstichnähten in der Textilindustrie.



Any use of these machines which is not approved by the manufacturer shall be considered as improper use! The manufacturer shall not be liable for any damage arising out of improper use! Proper use shall also be considered to include compliance with the operation, adjustment, service and repair measures specified by the manufacturer!

**3 Specifications****3.01 PFAFF 1525, PFAFF 1526**

Stitch type: ..... 301 (lockstitch)

Needle system: ..... 134-35

Version:

PFAFF 1525: ..... CN8; DN8

PFAFF 1526: ..... CN8

Needle sizes in 1/100 mm:

Version CN8: ..... 100 - 140

Version DN8: ..... 150 - 200

Max. thread size max. ( Synthetik▲):

Version CN8: ..... 15/3

Version DN8: ..... 8/3

Fabric clearance: ..... 18 mm

Clear workspace width: ..... 285 mm

Clear workspace height: ..... 115 mm

Max. stitch length: ..... 8 mm

Noise data:

Emission sound level at the workplace at appropriate speed

(Noise measurement in accordance with DIN 45 635-48-A-1, ISO 11204, ISO 3744, ISO 4871)

PFAFF 1525 at a speed of 2800 spm.: .....  $L_{pA} = 78 \text{ dB(A)}$  ■PFAFF 1526 at a speed of 2400 spm.: .....  $L_{pA} = 80 \text{ dB(A)}$  ■

Motordaten: ..... siehe Typenschild des Motors

Air consumption per working cycle: ..... 0,146 NI

Net weight of sewing head, PFAFF 1525: ..... approx. 50 kg

Net weight of sewing head, PFAFF 1526: ..... approx. 52 kg

Gross weight, PFAFF 1525: ..... approx. 58 kg

Gross weight, PFAFF 1526: ..... approx. 60 kg

◆ Subject to alterations

▲ synthetic, or other sizes of comparable thread types

■  $K_{pA} = 2,5 \text{ dB}$

# Specifications

## Maximum sewing speed

The maximum sewing speed depends on the material to be sewn, and thus on the top feed stroke.

| Top feed stroke | PFAFF 1525, 1525-S,<br>Max. speed/min.<br>Version B and C | PFAFF 1525-G,<br>Max. speed/min.<br>Version C | PFAFF 1525-G,<br>Max. speed/min.<br>Version D |
|-----------------|---|---|---|
| 1 - 2 mm        | 4000  | 3400  | 2700  |
| 2,5 - 4 mm      | 2800  | 2800  | 2700  |
| 4,5 - 5 mm      | 2200  | 2200  | 2200  |
| 5,5 - 7 mm      | 1800  | 1800  | 1800  |

| Top feed stroke | PFAFF 1526 Max. sewing speed in s.p.m. at needle gauges: |       |       |       |       |
|-----------------|--|-------|-------|-------|-------|
|                 | 6 mm   | 12 mm | 20 mm | 28 mm | 40 mm |
| 1 mm            | 3800   | 3600  | 3400  | 3200  | 3000  |
| 2 mm            | 3400   | 3200  | 3000  | 2850  | 2700  |
| 3 mm            | 3000   | 2850  | 2700  | 2500  | 2300  |
| 4 mm            | 3000   | 2500  | 2300  | 2150  | 2000  |
| 5 mm            | 2200   | 2100  | 2000  | 1900  | 1800  |
| 6 mm            | 1800   | 1900  | 1800  | 1700  | 1600  |
| 7 mm            | 1800   | 1700  | 1600  | 1500  | 1400  |

## 3.02 Available versions and workaids

Version CN8: ..... for sewing medium-heavy materials

Version DN8: ..... for sewing heavy materials

### Work aids:

-731/02 ..... Edge trimmer

-900/81 ..... Thread trimmer

-900/82 ..... Thread trimmer

-900/86 ..... Thread trimmer

-909/12 ..... pneumatically-controlled thread clamp

-910/04 ..... Automatic presser foot lift

-911/35 ..... Backtacking mechanism

-918/29 ..... Quick-change stepping control and stitch-length adjustment

-926/06 ..... Bobbin thread supply monitor

### 4 Disposal of Machine

- Proper disposal of the machine is the responsibility of the customer.
- The materials used for the machine are steel, aluminium, brass and various plastic materials.  
The electrical equipment comprises plastic materials and copper.
- The machine is to be disposed of according to the locally valid pollution control regulations; if necessary, a specialist is to be commissioned.



Care must be taken that parts soiled with lubricants are disposed of separately according to the locally valid pollution control regulations!

---

## *Transportation, packing and storage*

---

### 5 Transportation, packing and storage

#### 5.01 Transportation to customer's premises

The machines are delivered completely packed.

#### 5.02 Transportation inside the customer's premises

The manufacturer cannot be made liable for transportation inside the customer's premises nor to other operating locations. It must be ensured that the machines are only transported in an upright position.

#### 5.03 Disposal of packing materials

The packing materials of this machine comprise paper, cardboard and VCE fibre. Proper disposal of the packing material is the responsibility of the customer.

#### 5.04 Storage

If the machine is not in use, it can be stored as it is for a period of up to six months, but it should be protected against dust and moisture.

If the machine is stored for longer periods, the individual parts, especially the surfaces of moving parts, must be protected against corrosion, e.g. by a film of oil.

### 6 Explanation of symbols

In this instruction manual, work to be carried out or important information is accentuated by symbols. These symbols have the following meanings:



Note, information



Cleaning, care



Lubrication

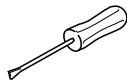

Maintenance, repairs, adjustment, service work  
(only to be carried out by technical staff)

## 7

### Controls

#### 7.01

#### On/off switch

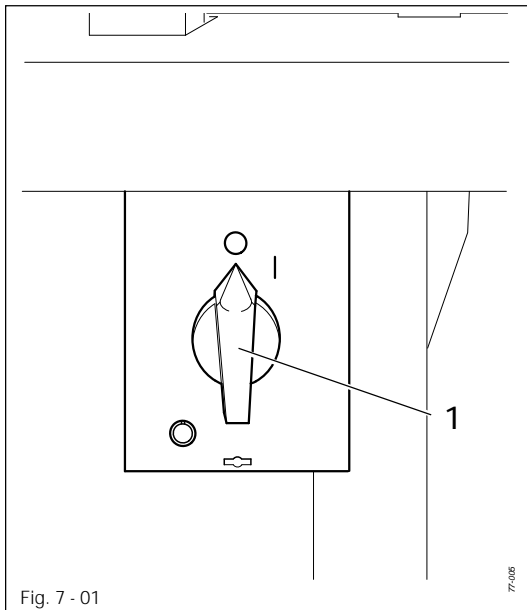

#### Maschinen with Quick-EcoDrive

- The power supply to the machine is switched on or off by turning switch 1.

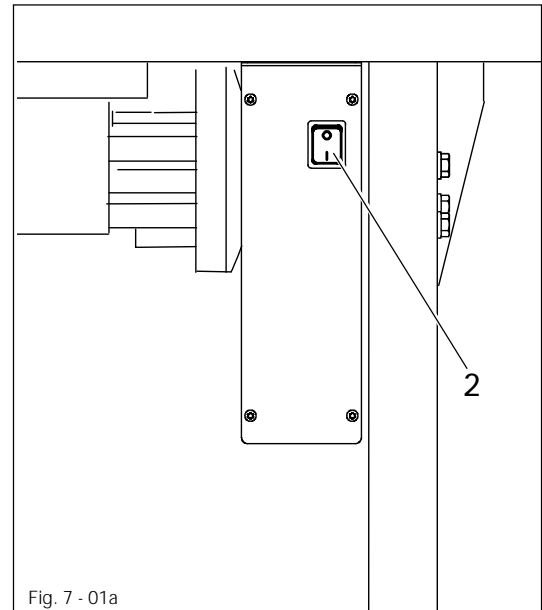

#### Maschinen with Quick-PicoDrive

- Operate main switch 2 to switch the machine on or off.

#### 7.02

#### Keys on machine head

(no keyboard on the PFAFF 1525-S)

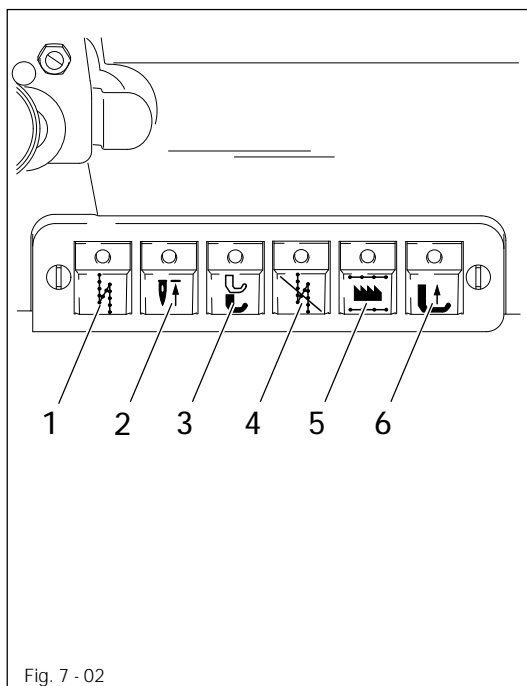

- The keys on the machine head are pressed to set off certain functions.

Key 1: Reverse sewing or intermediate backtack within the seam

Key 2: Raise needle

Key 3: Activate pre-set top-feed stroke (on machines with quick-change stepping control) -918/29)  
 Diode on = high stroke  
 Diode off = low stroke

Key 4: Switch off backtack function for one tack

Key 5: Activate pre-set stitch length (on machines with quick-change stepping control -918/29)  
 Diode on = long stitch length  
 Diode off = short stitch length

Key 6: EMERGENCY key. presser foot and needle are raised and the machine switched off (diode on).



7.03

Pedal

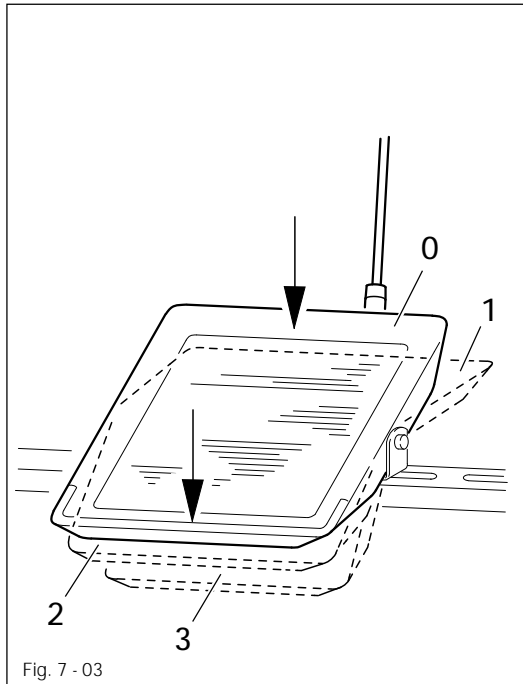

0 = Neutral position

1 = Sewing

2 = Raise presser foot

3 = Trim sewing threads



Other pedal functions are listed in the instruction manual for the control panel.

7.04

Knee switch

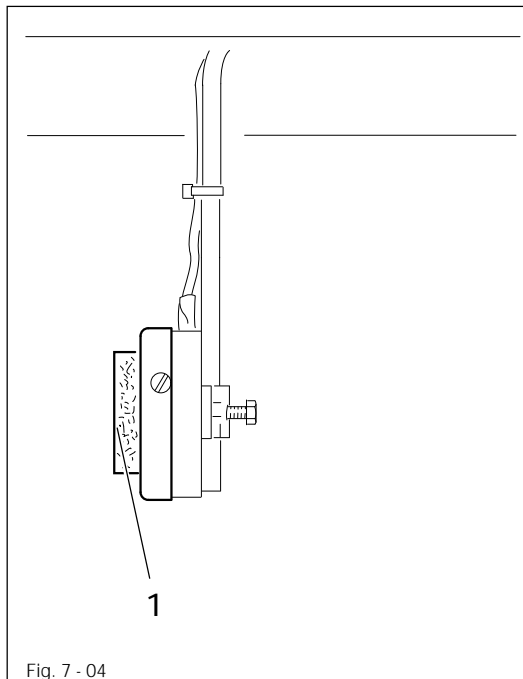

- By operating knee switch 1 it is possible to alternate between two pre-selected feed stroke settings.



For the high stroke setting the speed is reduced.

The knee switch function can be altered, see the instruction manual for the control panel.

## 7.05 Presser foot fixing key

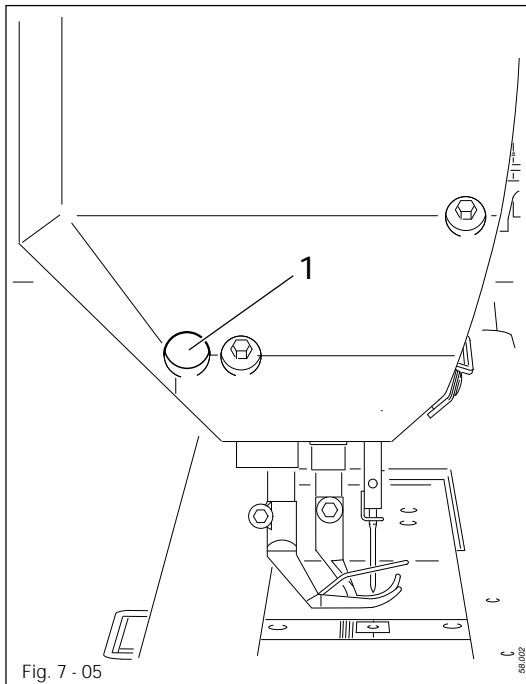

- To fix the presser foot, raise it with the pedal, then press key 1 and release the pedal again.
- To release the presser foot, raise it briefly with the pedal.

## 7.06 Adjusting the stitch length (on the PFAFF 1525 and 1526)

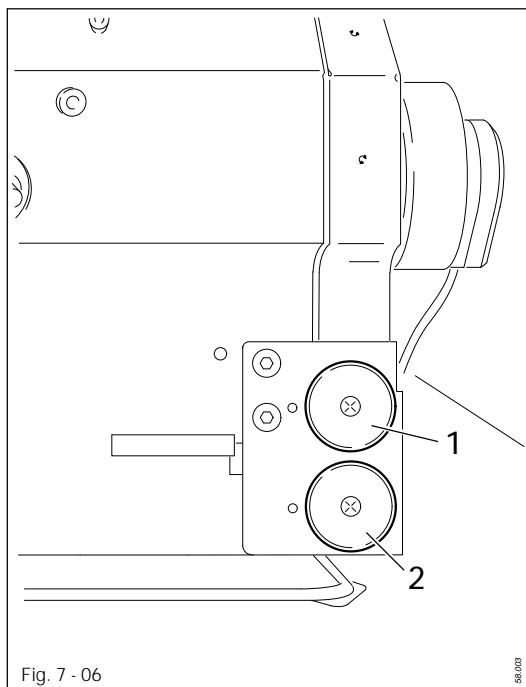

- The thumb wheels 1 and 2 can be used to pre-select the stitch lengths.
- The adjustment is made by pressing and at the same time turning the thumb wheels.
- The maximum stitch length is set with thumb wheel 1 and the minimum stitch length with thumb wheel 2.
- The pre-selected stitch lengths can be called up with key 5, see Chapter 7.02 Keys on the machine head.

7.07 Adjusting the stitch length (on the PFAFF 1525-S)

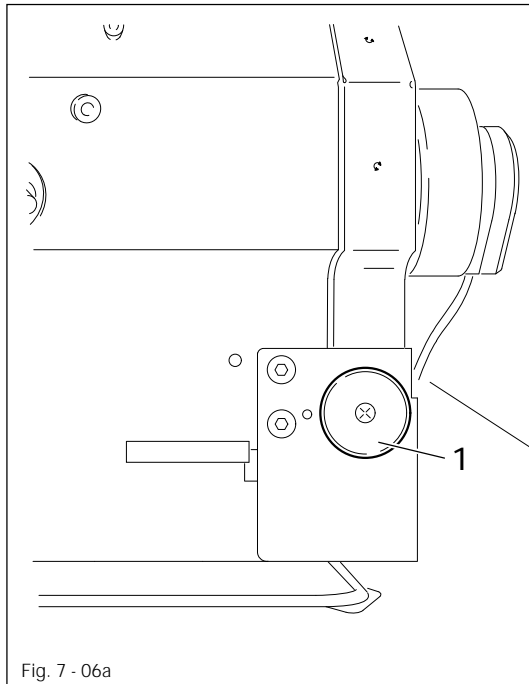

- Adjustment wheel 1 is used to pre-select the stitch length.

7.08 Reverse-feed control

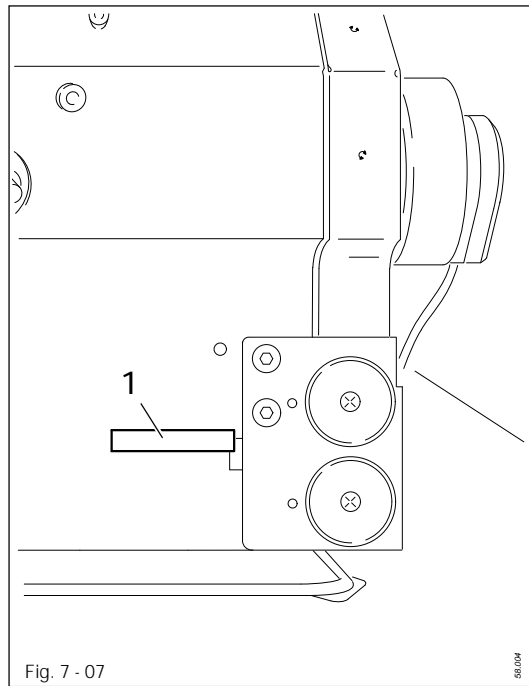

- To sew in reverse, press reverse-feed control lever 1.

## 7.09 Edge trimmer -731/02

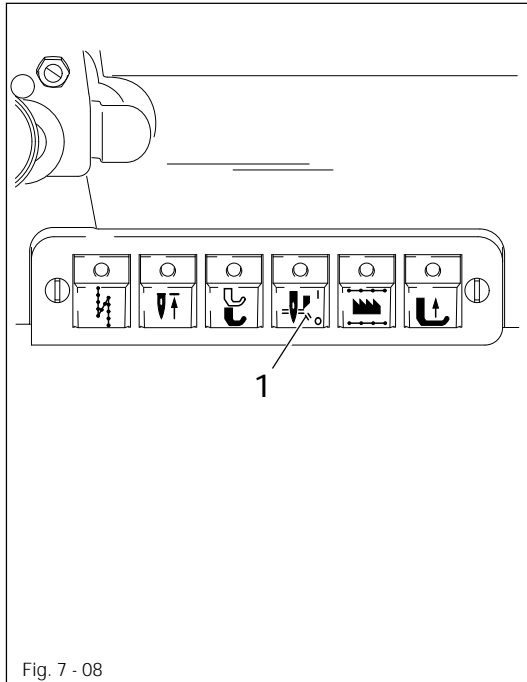

Keep your hands away from the moving knife! Danger of injury!

- Press key 1 to switch the knife drive on or off.



The bartack suppression key is omitted, see **Chapter 7.02 Keys on the machine head.**

## 7.10 Secondary needle-thread tension

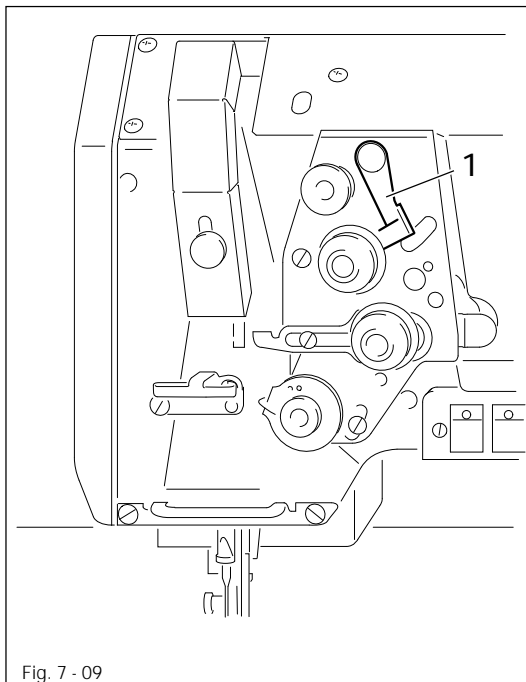

- To increase the needle-thread tension dis-engage lever 1 by pushing it to the right.

7.11 Adjusting the top feed stroke

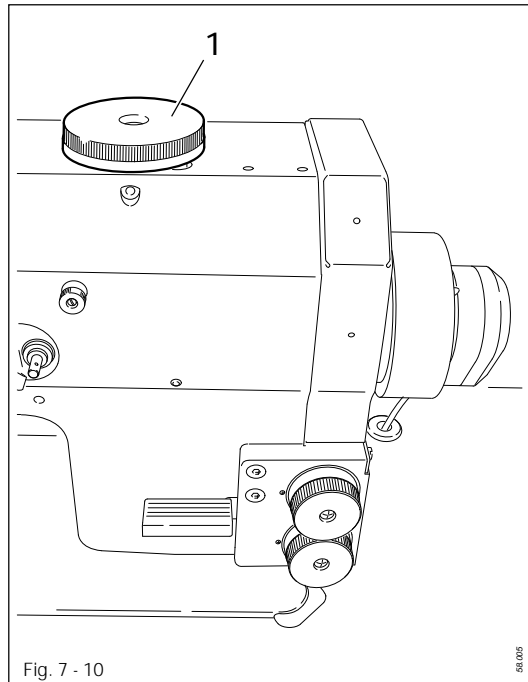

- The top feed stroke can be adjusted by turning knob 1.



The maximum top feed stroke is limited by the manufacturer. The limitation can be altered by skilled personnel, see **Adjustment Manual Chapter 13.05.11 Top feed lift.**

7.12 Bobbin thread supply monitor -926/06

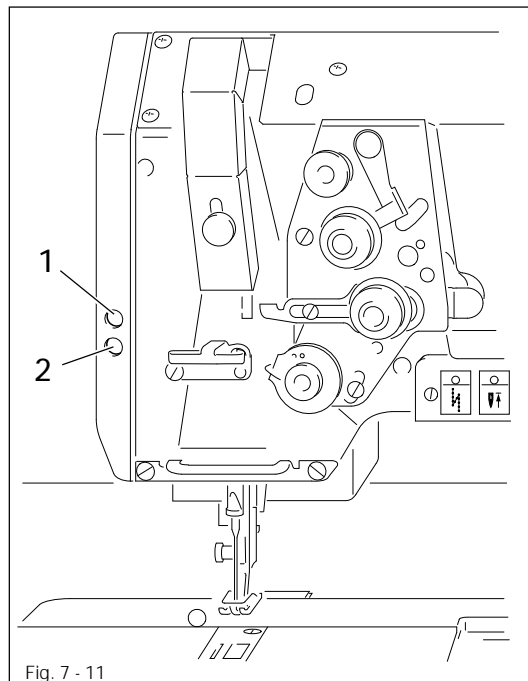

**PFAFF 1525**

- When the set thread-end length is reached, diode 1 flashes and the machine is stopped.

**PFAFF 1526**

- When the set thread end-length is reached, diode 1 (left bobbin) or 2 (right bobbin) flashes.

To finish sewing the seam, release the pedal and press it forwards again.

7.13

## Bobbin thread control by stitch counting

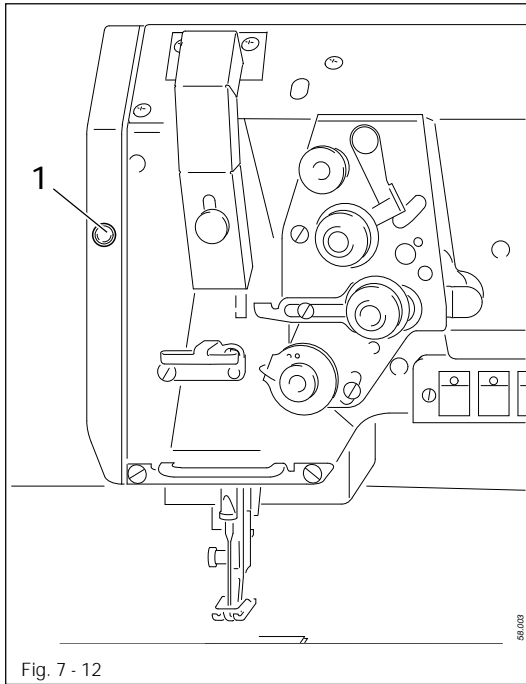

Fig. 7 - 12

- When the pre-set number of stitches is reached, LED 1 flashes.



After a bobbin change, the "scroll" key on the control panel must be pressed.

- Pre-setting the number of stitches, see the instruction manual for the control panel.

7.14

## Control panel (only on machines with Quick-EcoDrive or Quick-EcoDrive)

The description can be found in the separate instruction manual for the control panel.

## 8 Installation and commissioning



The machine must only be mounted and commissioned by qualified personnel! All relevant safety regulations are to be observed!



If the machine is delivered without a table, it must be ensured that the frame and the table top which you intend to use can hold the weight of the machine and the motor. It must be ensured that the supporting structure is sufficiently sturdy, including during all sewing operations.

### 8.01 Installation

The necessary electricity supply must be available at the machine's location. There must be a stable and horizontal surface and adequate lighting at the machine's location.



The method of packaging used requires that the table top be lowered for transport. The following is a description of how to adjust the height of the table top.

#### 8.01.01 Adjusting the table-top height

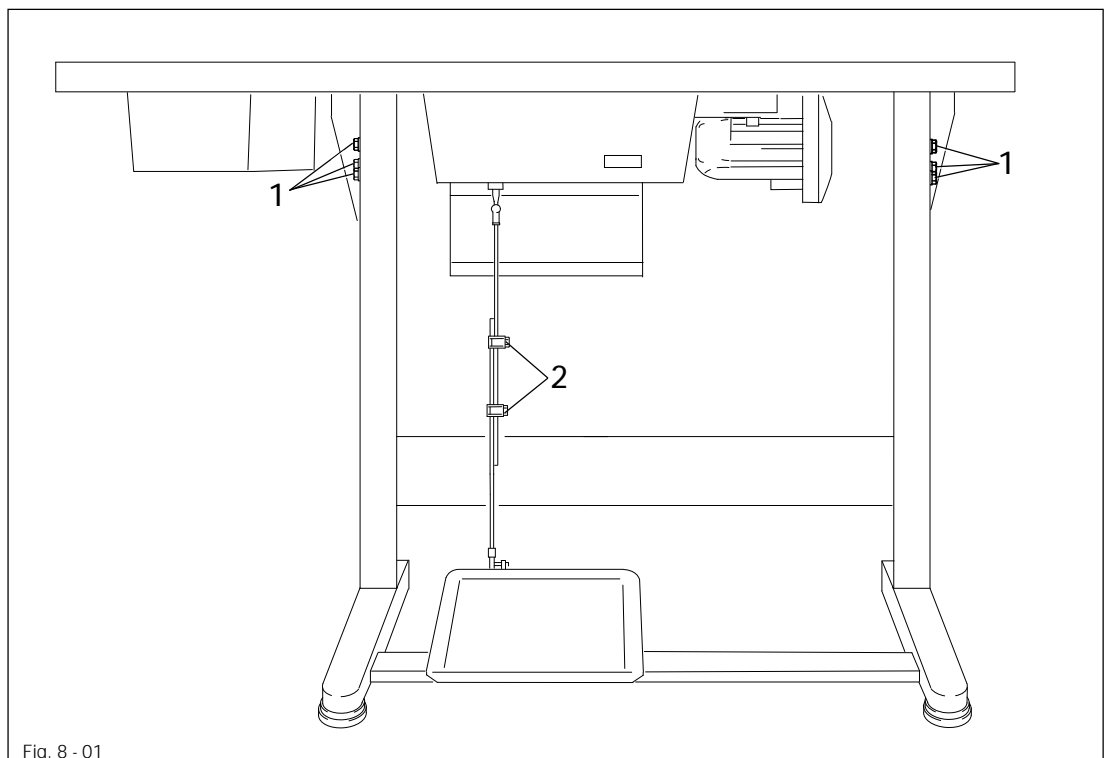

- Loosen screws 1 and 2 and set the desired table-top height
- Tighten screws 1 well.
- Adjust the position of the pedal so that you can operate it comfortably and tighten screw 2.

# Installation and commissioning

## 8.01.02 Assembling the motor (only on machines with Quick-motor)

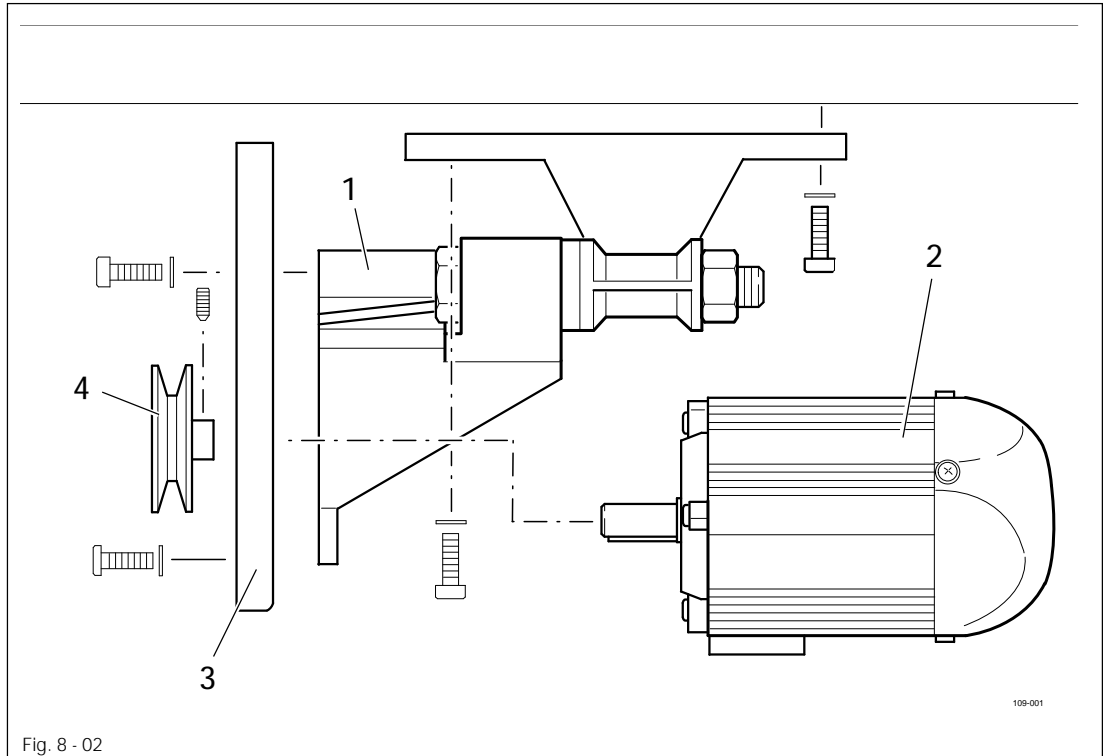

- Assemble motor mounting 1, motor 2, belt guard support 3 and belt pulley 4 as shown in Fig. 8-02.

## 8.01.03 Tightening the V-belt

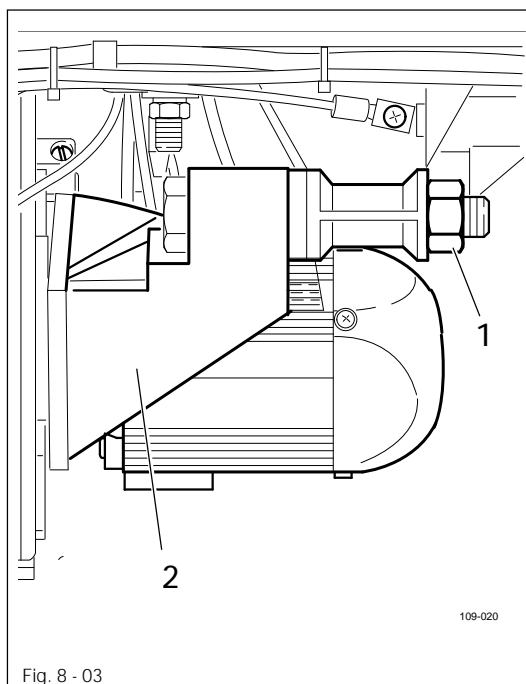

- Fit the V-belt.
- Loosen nut 1 and tighten the V-belt by turning motor mounting 2.
- Tighten nut 1.



## 8.01.04 Mounting the bottom V-belt guard

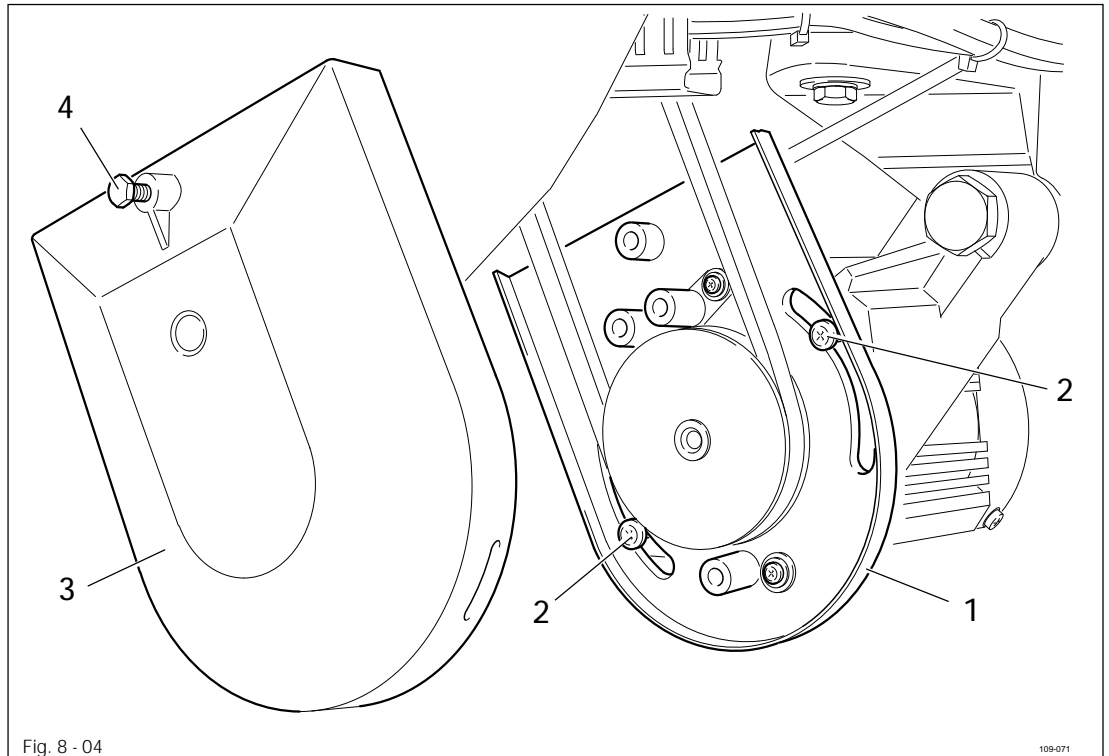

- Loosen screws 2 and adjust belt guard support 1 so that the motor pulley and V-belt run freely.
- Tighten screws 2.
- Fasten belt guard 3 with screw 4.



**Fig. 8-04** shows a Quick-motor. If a different motor is used, follow the instructions of the Motor Instruction Manual.

## 8.01.05 Fitting the upper V-belt guard

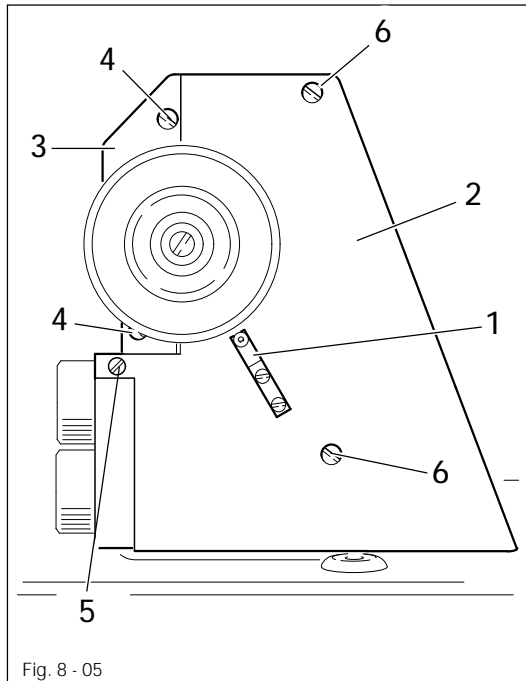

- Screw position stop 1 to the right belt guard section 2.
- Attach belt guard section 3 with screws 4.
- Push the slots of the right belt guard section 2 behind the heads of retaining screws 2 and attach it with screws 5 and 6.

## 8.01.06 Fitting the synchronizer

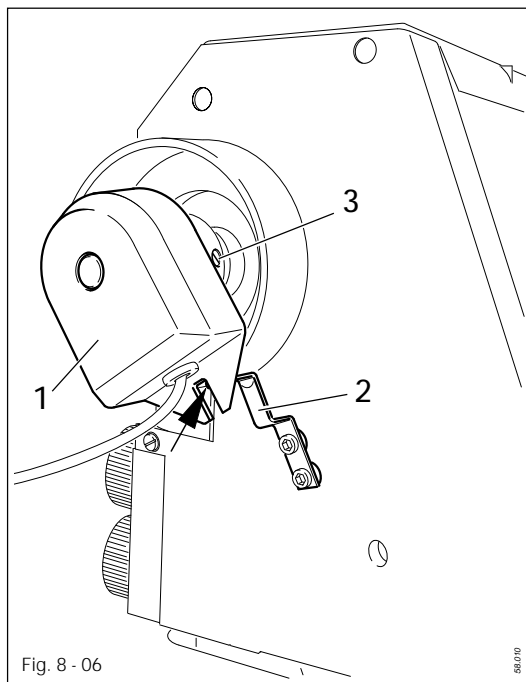

- Push synchronizer 1 onto the shaft so that stop 2 is standing in the slot on the synchronizer (see arrow)
- Tighten screws 3.
- Connect the synchronizer plug to the control box.
- Adjust the synchronizer, see Chapter 8.05 Basic position of the machine.

## 8.01.07 Fitting the tilt lock

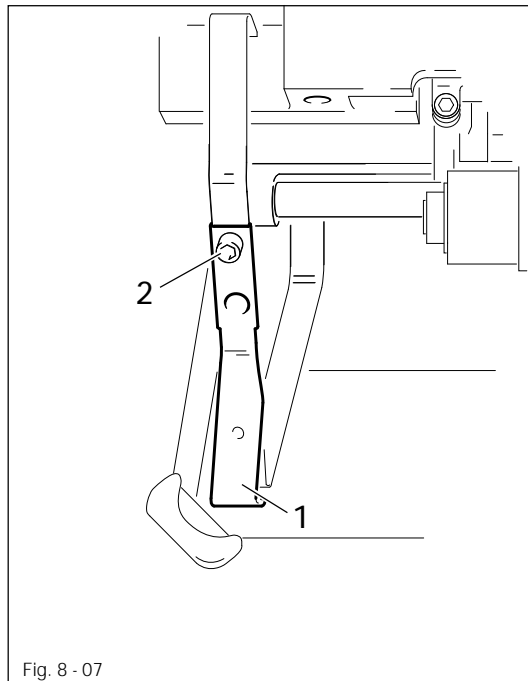

Fig. 8 - 07

- Screw on tilt lock 1, provided in the accessories, using screw 2.



Do not operate the machine without tilt lock 1!  
Danger of crushing between sewing head and table top!

## 8.01.08 Fitting the reel stand

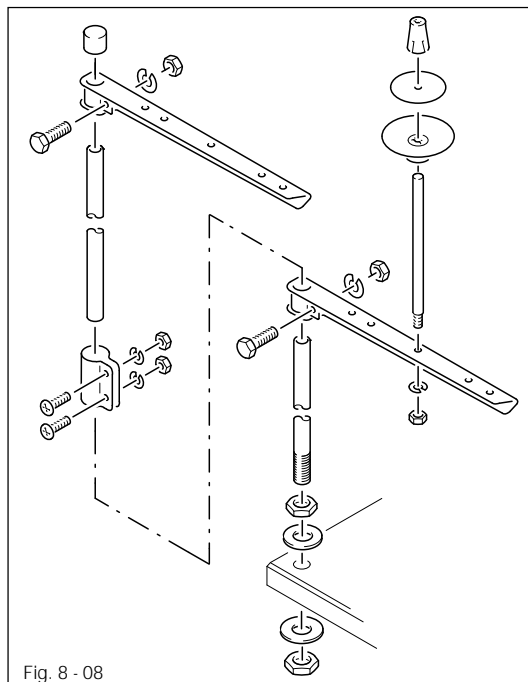

Fig. 8 - 08

- Fit the reel stand as shown in Fig. 8 - 08.
- Afterwards insert the stand in the hole in the table top and secure it with nuts provided.

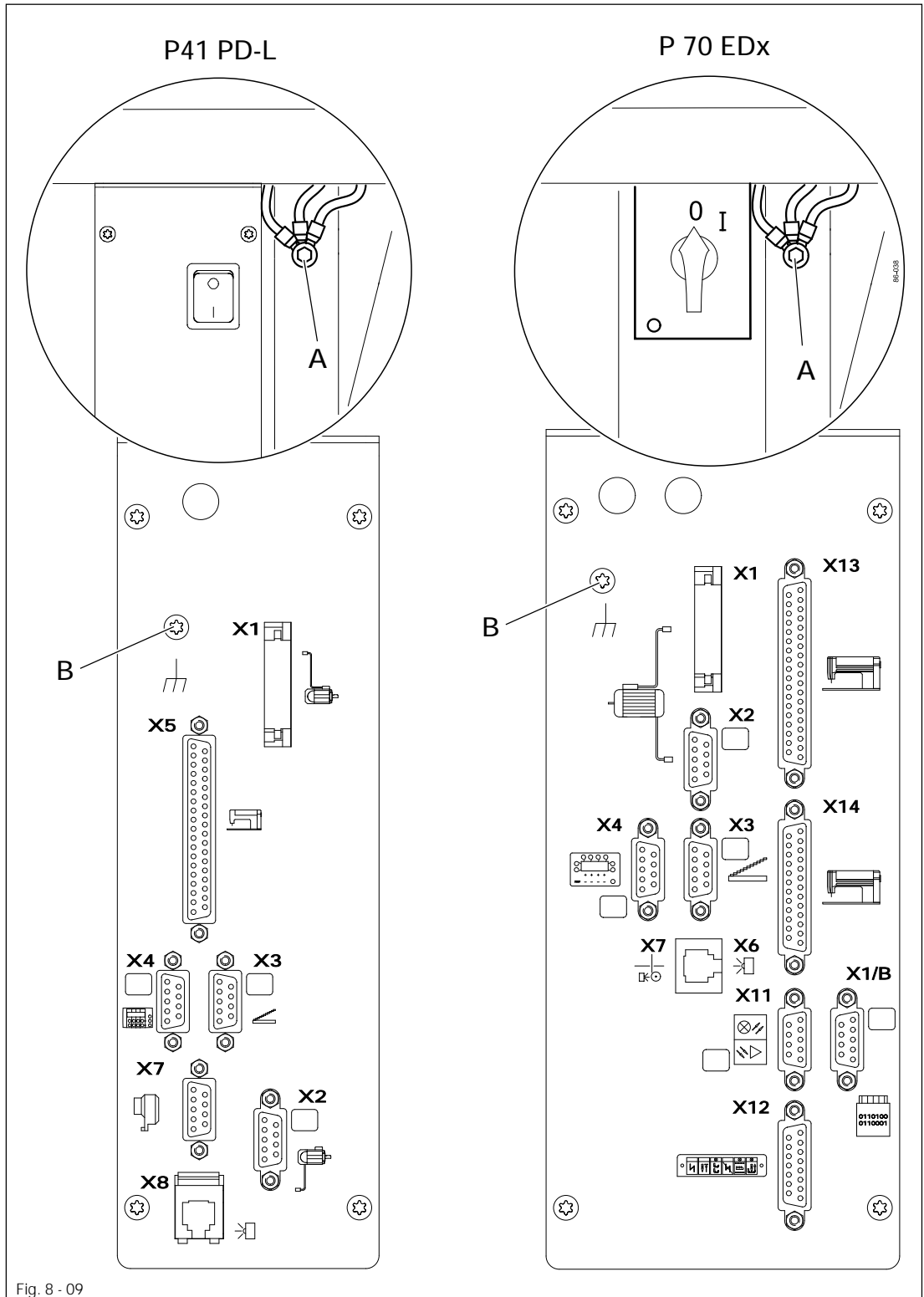

Table top mounting and circuit diagrams  
(see Chapter 11)

# Installation and commissioning

8.02

Connecting the plug-in connections and earth cables



- Connect all plugs as labelled to the control box .
- Screw the earth cable from the sewing head and the main switch to earth point A.
- Connect earth point A to earth point B with earth cable.
- Fasten the earth cable from plug X1 to earth point B.

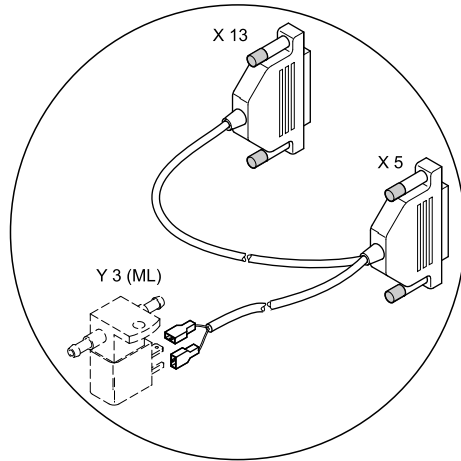

### Attention!

When using the control unit P41 PD-L, the cable of the adapter lead must be connected to oil valve Y3.

## 8.03 Installation

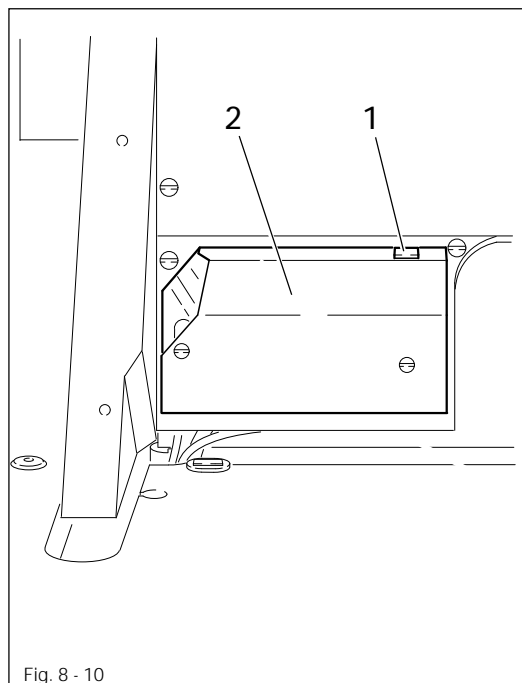

Fig. 8 - 10

- Check the machine, particularly its electrical wiring and pneumatic tube connections, for any damage.
- Remove stopper 1 from oil tank 2. The stopper is only used as a transit lock and must not be used during sewing operation.
- Clean the machine thoroughly and afterwards fill with oil and oil the machine (see Chapter 10, Care and maintenance).
- Have skilled personnel check if the machine can be operated with the available mains voltage.



Do not operate the machine if there is any discrepancy.



Before starting the machine for the first time, have specialists check whether the parameter 799 (machine class) is set at "3" or "5", depending on the control unit, and parameter 800 (rotation direction) is set at "1". If necessary have this adjustment carried out (see Chapter 8.05 Basic setting of the machine drive).



The machine may only be connected to an earthed socket!

- Connect the machine to the compressed air supply. When it is connected, the gauge should indicate a pressure of approx. 6 bar. If necessary have this reading correctly set (see Chapter 10.03, Checking/adjusting the air pressure).

### 8.04 Switching the machine on/off

- Switch the machine on (see Chapter 7.01, On/off switch).

### 8.05 Basic position of the machine drive unit

#### 8.05.01 On machines with Quick-EcoDrive and control unit P70ED

- Switch on the machine.
- Press the TE/speed key twice to select the input mode.
- Select parameter "798" by pressing the corresponding +/- key, and select service level C, see Chapter Selecting the user level in the instruction manual for the control panel.
- By pressing the corresponding +/- key select the parameter "799" (Selecting the machine class).
- Press the corresponding +/- key to set the value for the parameter at "3".
- By pressing the corresponding +/- key, select parameter "700".
- Sew a stitch by operating the pedal.
- Turn the balance wheel in the sewing direction until the descending needle is level with the top edge of the needle plate.
- Conclude the adjustment of the sewing motor by pressing the TE/Speed key.

#### 8.05.02 On machines with Quick-PicoDrive and control unit P41 PD-L

- Switch on the machine.
- Call up the parameter input by pressing the scroll key.
- Press the TE key to switch the function keys to input function (LED in the TE key is illuminated).
- Press the corresponding +/- keys to select parameter "798" and select the service level C, see chapter Selecting the User Level in the separate instruction manual for the control panel.
- Select parameter "799" by pressing the corresponding +/- keys.
- Check whether the value is set at "5" and alter if necessary.
- Switch the machine off and then on again.
- "Pulley" appears on the display.
- Call up the parameter input by pressing the scroll key.
- Press the TE key to switch the function keys to input function (LED in the TE key is illuminated).
- Press the corresponding +/- keys to select parameter "798" and select the service level C.
- Select parameter "800" by pressing the corresponding +/- keys.
- Check whether the value is set at "1" (balance wheel turns towards operator) and alter if necessary.
- Press the scroll key until "Pulley" appears on the display.
- If the pedal is operated, the control unit carries out a teach-in operation.
- The machine runs at low speed until the teach-in operation is completed. This operation cannot be interrupted.
- After the teach-in operation, the "Pulley" disappears from the screen - display returns to standard.
- Select parameter "700" by pressing the +/- keys.
- Sew one stitch by operating the pedal.
- Turn the balance wheel in the direction of rotation until the needle point, descending from above, is flush with the top edge of the needle plate.
- Conclude the adjustment of the sewing motor by pressing the scroll key.

9

Setting up



All instructions and regulations in this instruction manual must be observed. Special attention must be given to all safety regulations!



All setting-up work must only be done by personnel with the necessary training. For all setting-up work the machine must be isolated from its power supply by turning off the on/off switch or removing the machine plug from the electric power socket!

9.01

Inserting the needle

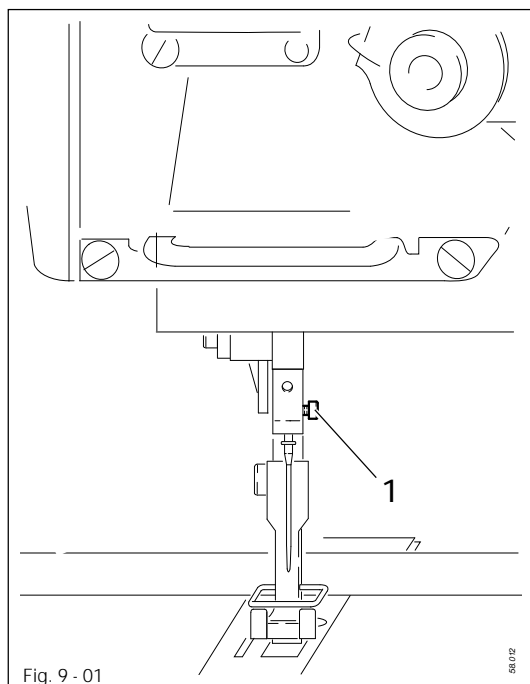

Fig. 9-01

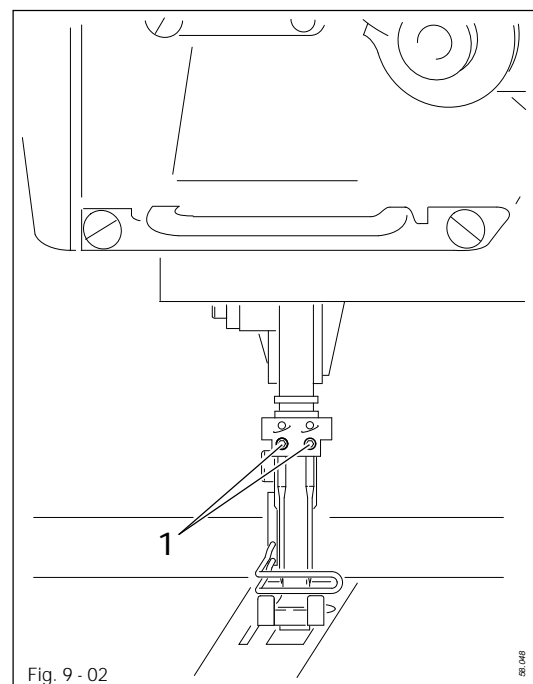

Fig. 9-02



Switch the machine off!  
Danger due to unintentional starting of the machine!



Only use needles from the system intended for the machine, see **Chapter 3 Specifications**.

**PFAFF 1525**

- Set needle bar at top position and loosen screw 1.
- Push the needle fully in (the long needle groove must face to the left).
- Tighten screw 1 again.

**PFAFF 1526**

- Set needle bar at top position and loosen screw 1.
- Push the needle fully in (the long groove of the left needle must face to the right and that of the right needle to the left).
- Tighten screw 1 again.



If the needle bar is adjusted accordingly, it is also possible to use needle system 134.

The choice of needle depends on the model of the machine and the thread and material used for sewing (see **Chapter 3, Specifications**).

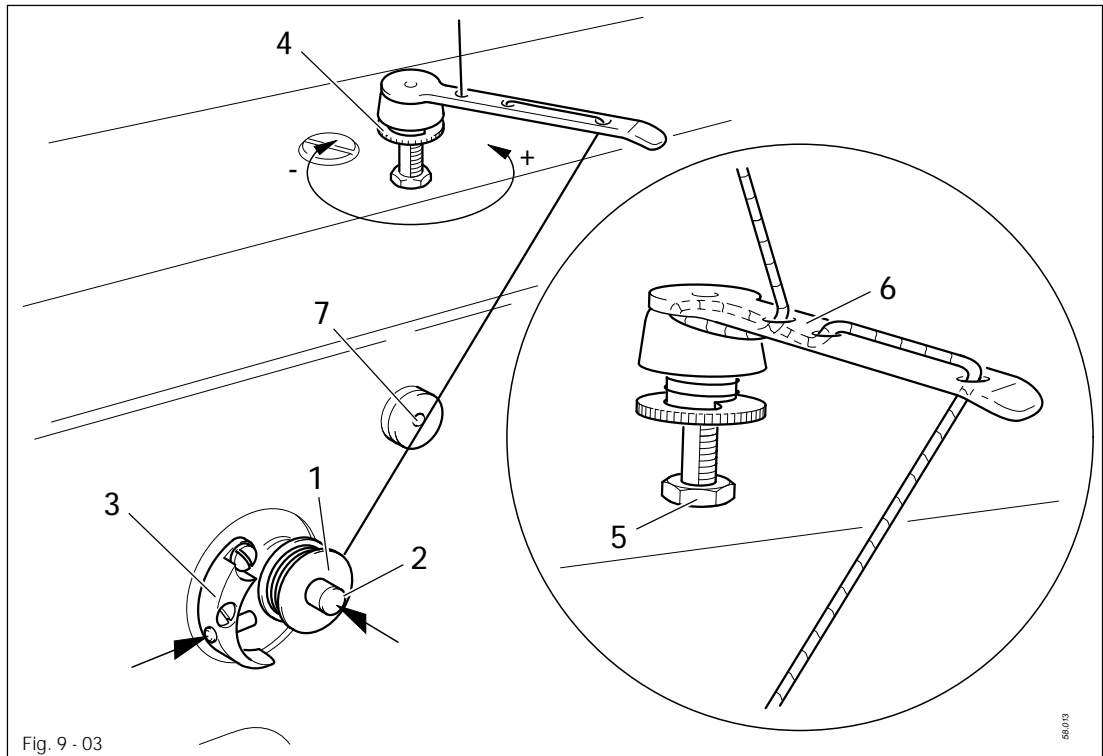

- Place an empty bobbin 1 on winder spindle 2.
- Thread up as shown in Fig. 9 - 03 and wind the thread a few times clockwise around bobbin 1.
- Engage the bobbin winder by pressing spindle 2 and lever 3 simultaneously.



The bobbin is wound during sewing.

- The tension of the thread wound onto bobbin 1 is set on milled screw 4.
- The bobbin winder will stop when sufficient thread is wound onto bobbin 1.
- Guide the thread under thread knife 7 and cut it off, whereby the end of the thread is fastened.

If the thread is wound on unevenly:

- Loosen nut 5.
- Turn thread guide 6 as required.
- Tighten nut 5 again.



9.03

Bobbin-changing/threading, and regulating the bobbin thread tension

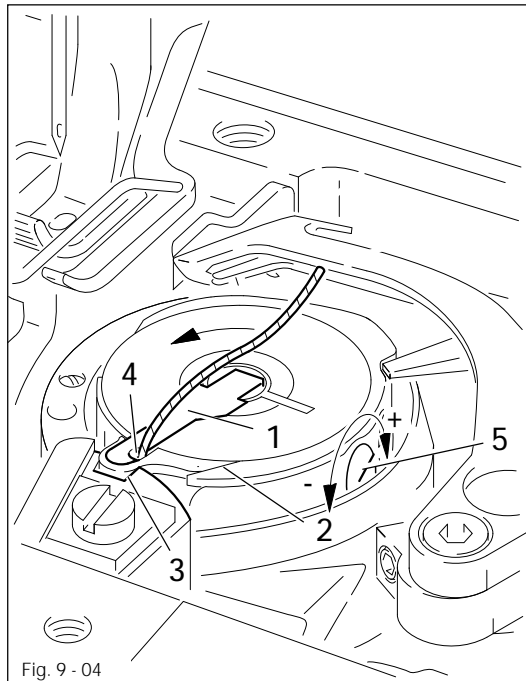

Switch the machine off!  
 Danger due to unintentional starting of the machine!

- Set take-up lever at its top position.
- Open bed slide, lift latch 1 and take out the bobbin. Place the filled bobbin into the hook so that the bobbin turns as shown by the arrow when the thread is pulled.
- Close latch 1 again.
- Pull the thread through slot 2, around stop 3 and into hole 4. Close the bed slide again.
- Regulate the bobbin-thread tension by turning screw 5.



Do not run the machine with the bed slide open.  
 Danger of injury by moving parts.

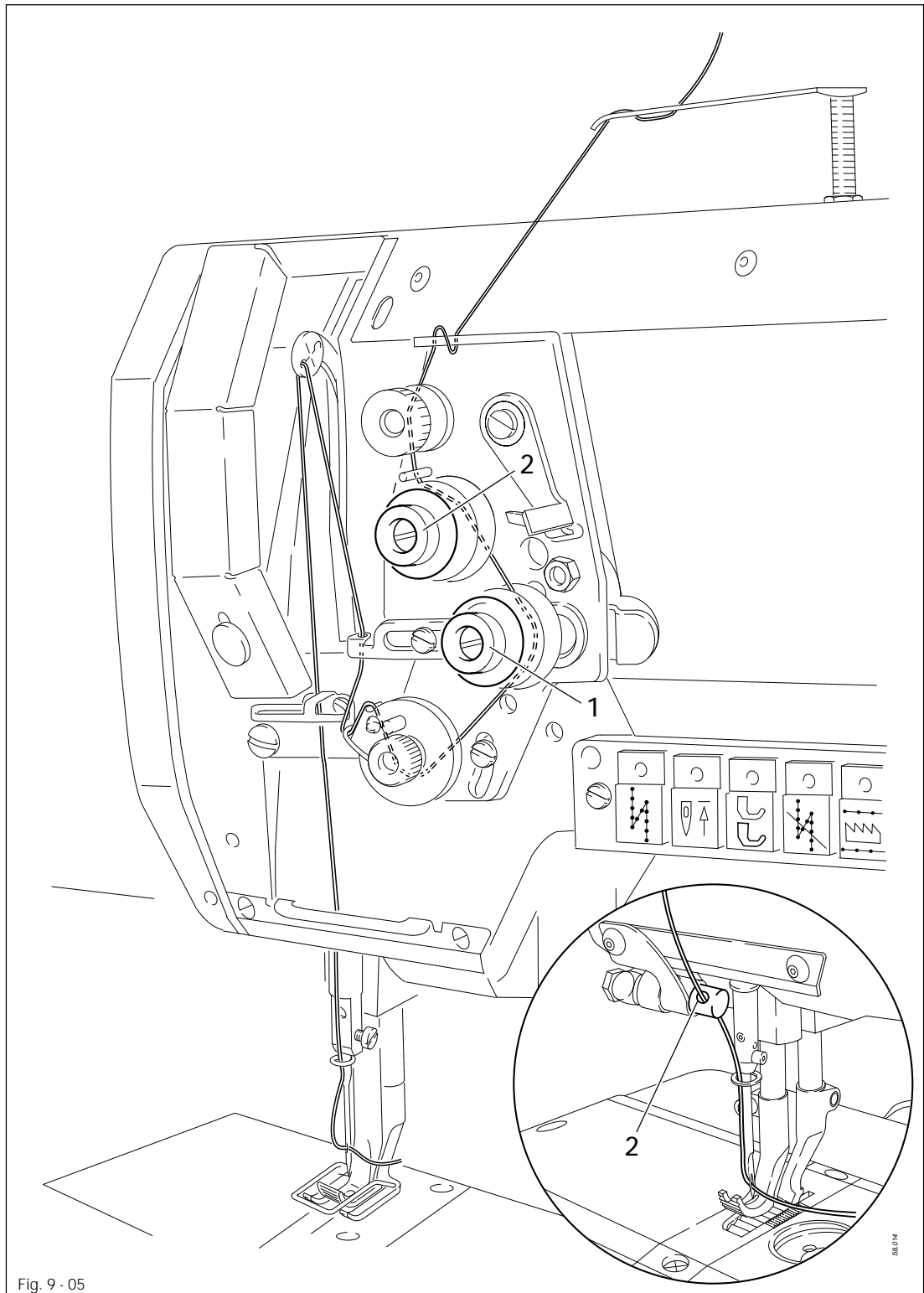

Switch the machine off!

Danger due to unintentional starting of the machine!

- Thread the needle thread as shown in Fig. 9 - 05.
- On machines with sub-class -909/12 guide the thread through ring 2.
- Regulate the needle-thread tension by turning milled screw 1 or 2.

9.05

Threading needle threads and regulating tensions on the PFAFF 1526

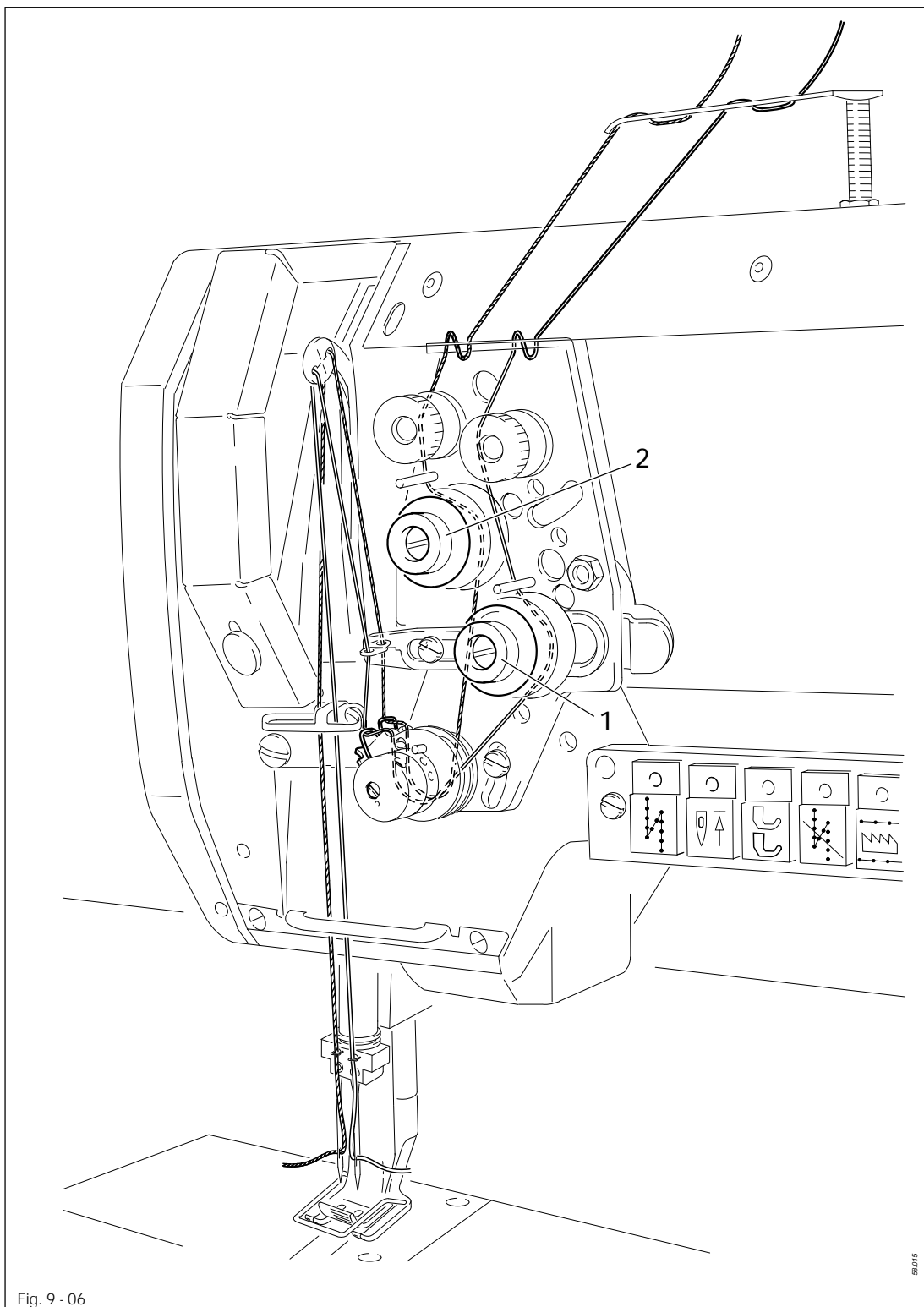

Switch the machine off!  
 Danger due to unintentional starting of the machine!

- Thread the needle thread as shown in Fig. 9 - 06.
- Regulate the needle-thread tension by turning milled screw 1 (right needle) or 2 (left needle).

## 10 Care and maintenance

|   |   |
|---|---|
| Clean hook area .....                           | daily; more frequently if in continuous operation |
| Check oil level (hook-oil container) .....      | daily, before operation                           |
| Check/adjust air pressure .....                 | daily, before operation                           |
| Clean air filter of air-filter/lubricator ..... | when required                                     |



These maintenance intervals apply to the average machine running time in single-shift operation. If machine running times are increased, it is advisable to shorten these intervals.

### 10.01 Cleaning the hook area

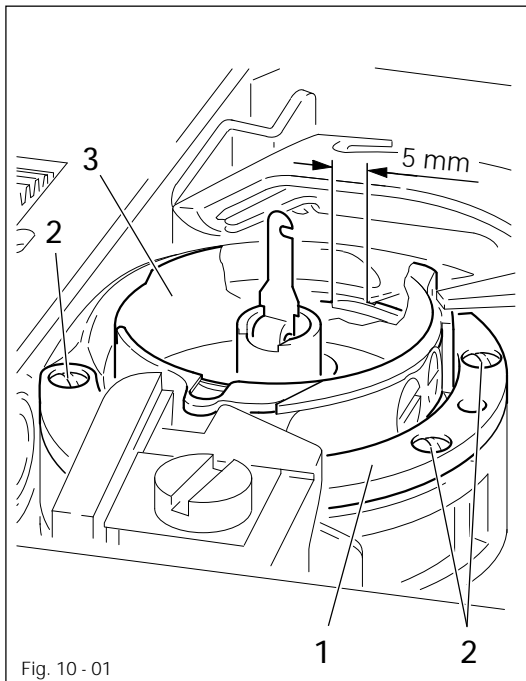

Switch the machine off!  
Danger due to unintentional starting of the machine!

- Set needle bar at its top position.
- Open bed slide and take out bobbin..
- Unscrew and remove hook gib 1 (screws 2).
- Turn the balance wheel until the tip of bobbin case 3 has entered the groove in the hook race by about 5 mm .
- Take out bobbin case 3.
- Clean the hook race.
- When inserting bobbin case 3 make sure that the lug of bobbin case 3 en-gages the cutout in the bobbin-case position stop.
- Screw on hook gib 1.
- Insert the bobbin and close the bed slide.

10.02 Oiling the hook

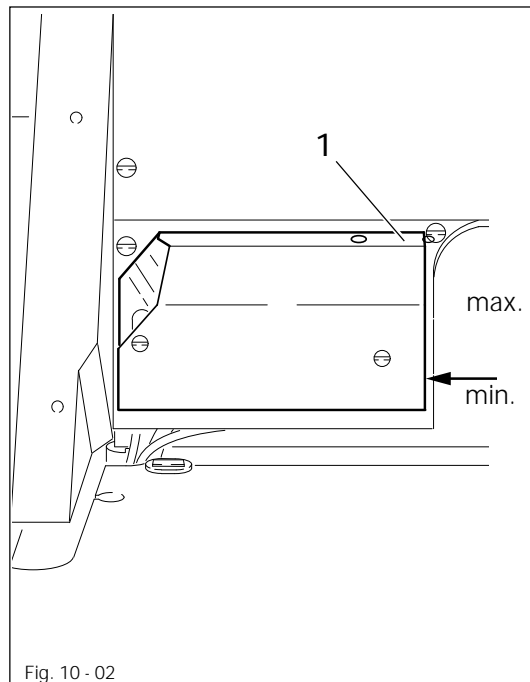

Fig. 10 - 02

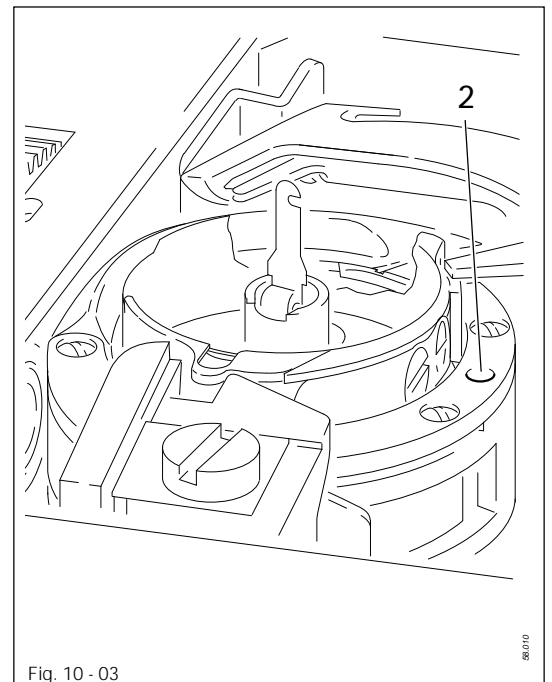

Fig. 10 - 03



Switch the machine off!  
Danger of injury due to unintentional starting of the machine!



Always check the oil level before starting operation.  
The oil level must not drop below the marking "**min.**", nor rise above the marking "**max.**".

- Top up the oil through hole 1 in the oil reservoir when required.
- Before commissioning the machine, and after longer periods out of operation, apply 1 to 2 drops of oil in hole 2 of the hook gib.



Only use oil with a medium viscosity of 22.0 mm<sup>2</sup>/s at 40° C and a density of 0.865 g/cm<sup>3</sup> at 15 C.

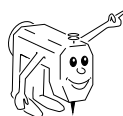

We recommend PFAFF sewing machine oil, No. 280-1-120 144.

### 10.03 Checking/adjusting the air pressure

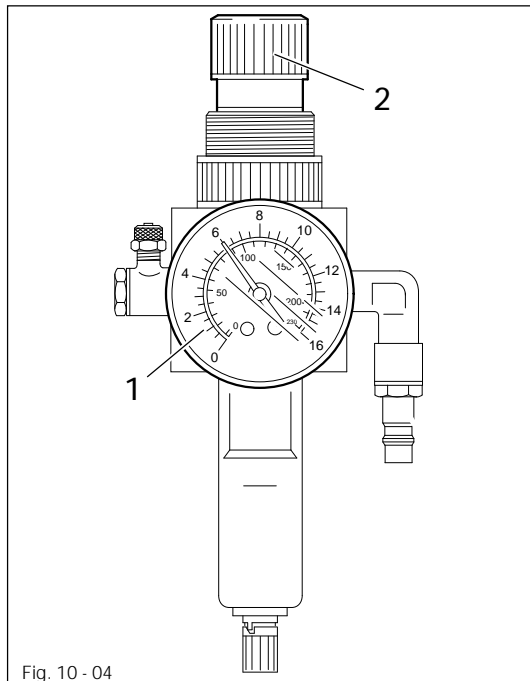

Fig. 10 - 04

- Before operating the machine, always check the air pressure on gauge 1.
- Gauge 1 must show a pressure of 6 bar.
- If necessary adjust to this reading.
- To do so, pull knob 2 upwards and turn it so that the gauge shows a pressure of 6 bar.

### 10.04 Cleaning the air filter of the air-filter/lubricator

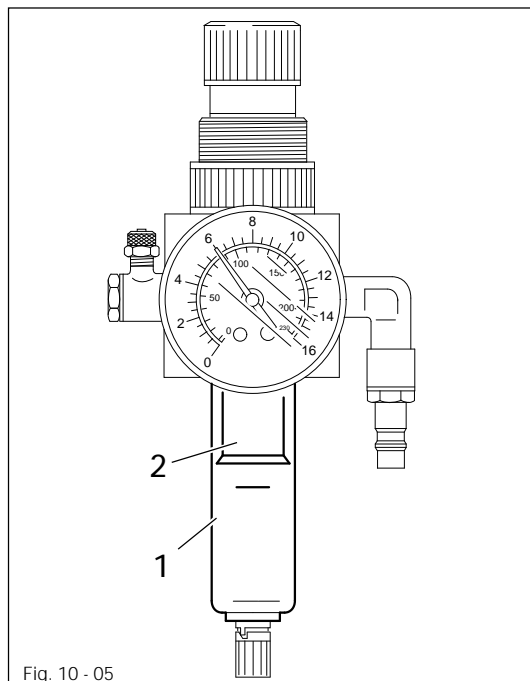

Fig. 10 - 05



Switch the machine off!  
Disconnect the air hose at the  
air-filter/lubricator.

#### To drain water bowl 1:

- Water bowl 1 drains itself automatically when the compressed-air hose is disconnected from the air-filter/lubricator.

#### Cleaning filter 2:

- Unscrew water bowl 1.
- Take out filter 2.
- Clean filter 2 with compressed air or isopropyl alcohol (part No. 95-665 735-91).
- Screw in filter 2 and screw on water bowl 1.

10.05 Parameter settings

(only on machines with Quick-EcoDrive and control unit P70ED or Quick-PicoDrive and control unit P41 PD-L)

- The selection of the user level and the alteration of parameters is described in the separate instruction manual for the drive unit.

10.05.01 Parameter list

| Group | Parameter   | Description  | User level         | Setting range | Set value P70 ED | Set value P41 PD-L |
|-------|---|--|--------------------|---------------|------------------|--------------------|
| 6     | 607   | Speed max.   | B, C               | 300 - 6000    | ▲                | ▲                  |
|       | 660   | Bobbin monitor function<br>0 = Off<br>I = by sensor (-926/06)<br>II = by stitch counting             | B, C               | 0 - II        | 0                | -                  |
| 7     | 700   | Needle position 0,<br>Needle reference position  | B, C               | 0 - 255       |                  |                    |
|       | 702   | Needle position 1 (needle lowered)<br>on the 1525 and 1526<br>on the 1526-G                          | B, C               | 0 - 255       | 80               | 85                 |
|       |   |  | B, C               | 0 - 255       | 25               |                    |
|       | 703   | Needle position 2 (take-up lever raised)<br>on the -900/81<br>on the -900/82<br>on the 1525-G-900/86 | B, C               | 0 - 255       | 213              | 234                |
|       |   |  | B, C               | 0 - 255       | 225              |                    |
|       |   |  | B, C               | 0 - 255       | 230              |                    |
|       | 705   | Needle position 5 (end cutting signal 1)<br>on the -900/81 and -900/86<br>on the -900/82             | B, C               | 0 - 255       | 175              | 186                |
|       |   |  | B, C               | 0 - 255       | 225              |                    |
| 707   | Needle position 6<br>(Start tension release signal 2)<br>on the 1525 and 1526<br>on the 1525-G                        | B, C<br>B, C   | 0 - 255<br>0 - 255 | 180<br>200    | 192              |                    |
| 727   | Counter for bobbin monitoring brings<br>ON = stop and signal at output Y36<br>OFF = signal at output Y36 without stop | B, C   | ON - OFF           | 0             | -                |                    |
| 760   | Multiplier for the fixed value (200) for<br>stitch count  | A, B, C  | 0 - 250            | 10            | -                |                    |

▲ See Chapter 3 Specifications

| Group | Parameter | Description  | User level | Setting range | Set value P70 ED | Set value P41 PD-L |
|-------|-----------|--|------------|---------------|------------------|--------------------|
| 7     | 799       | Selected machine class   | C          | 1 - 4         | 3                | -                  |
|       |           |  | C          | 1 - 5         | -                | 5                  |
| 8     | 800       | Rotating direction of the motor  | C          | 0 - 1         | 1                | 1                  |
| 9     | 989       | Thread trapper at beginning of seam<br>0 = OFF<br>I = ON<br>II = ON and raise presser foot | C          | 0 - 2         | 0                | 0                  |



Further parameters and the description for an internet update of the machine software and reset /cold start of the machine can be found in the instruction manual for the control panel.



11.01 Table top cutout

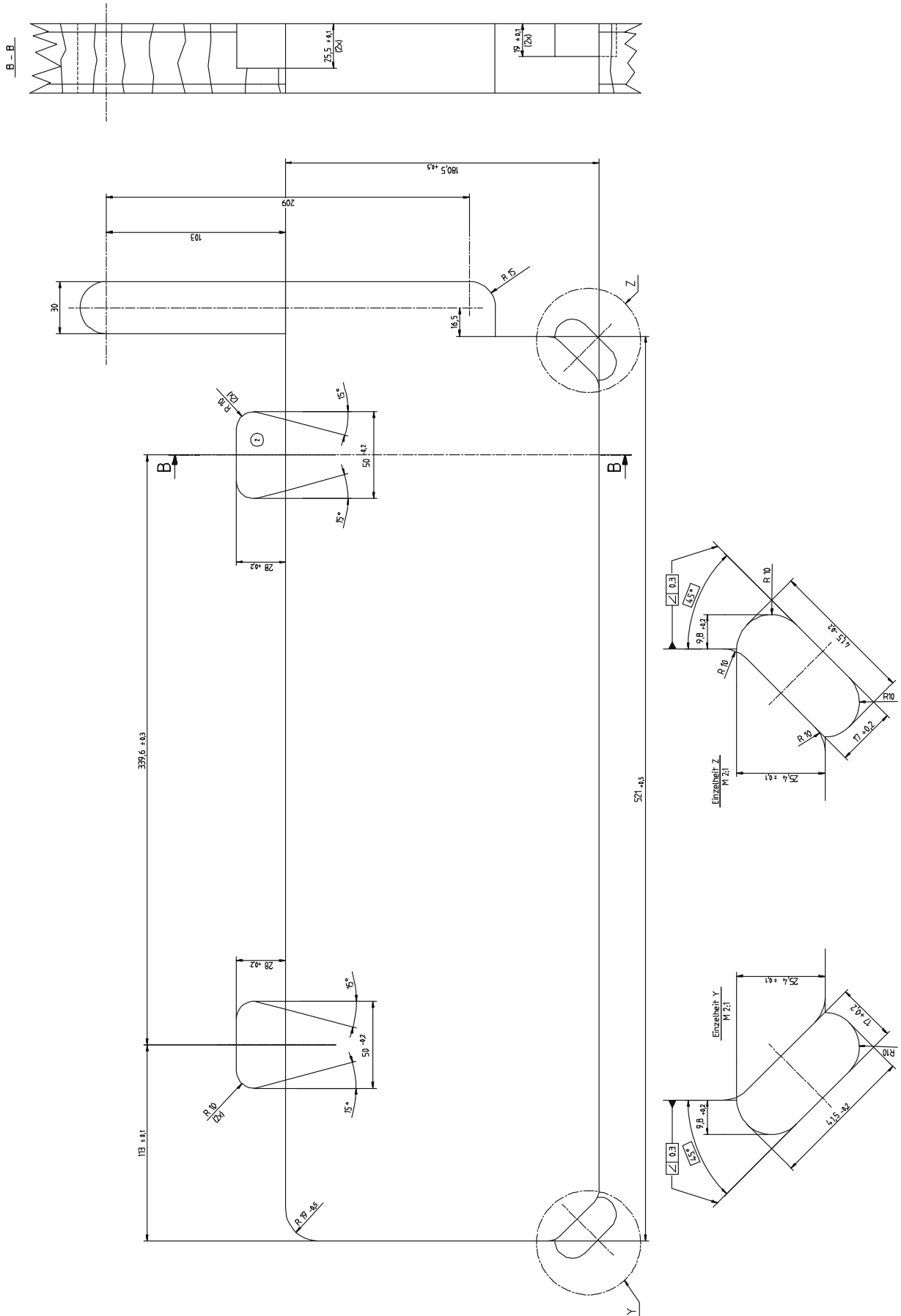

906-7000-405

# Mounting the table top

## 11.02 Mounting the table top (with Quick-EcoDrive and control unit P 70 EDx)

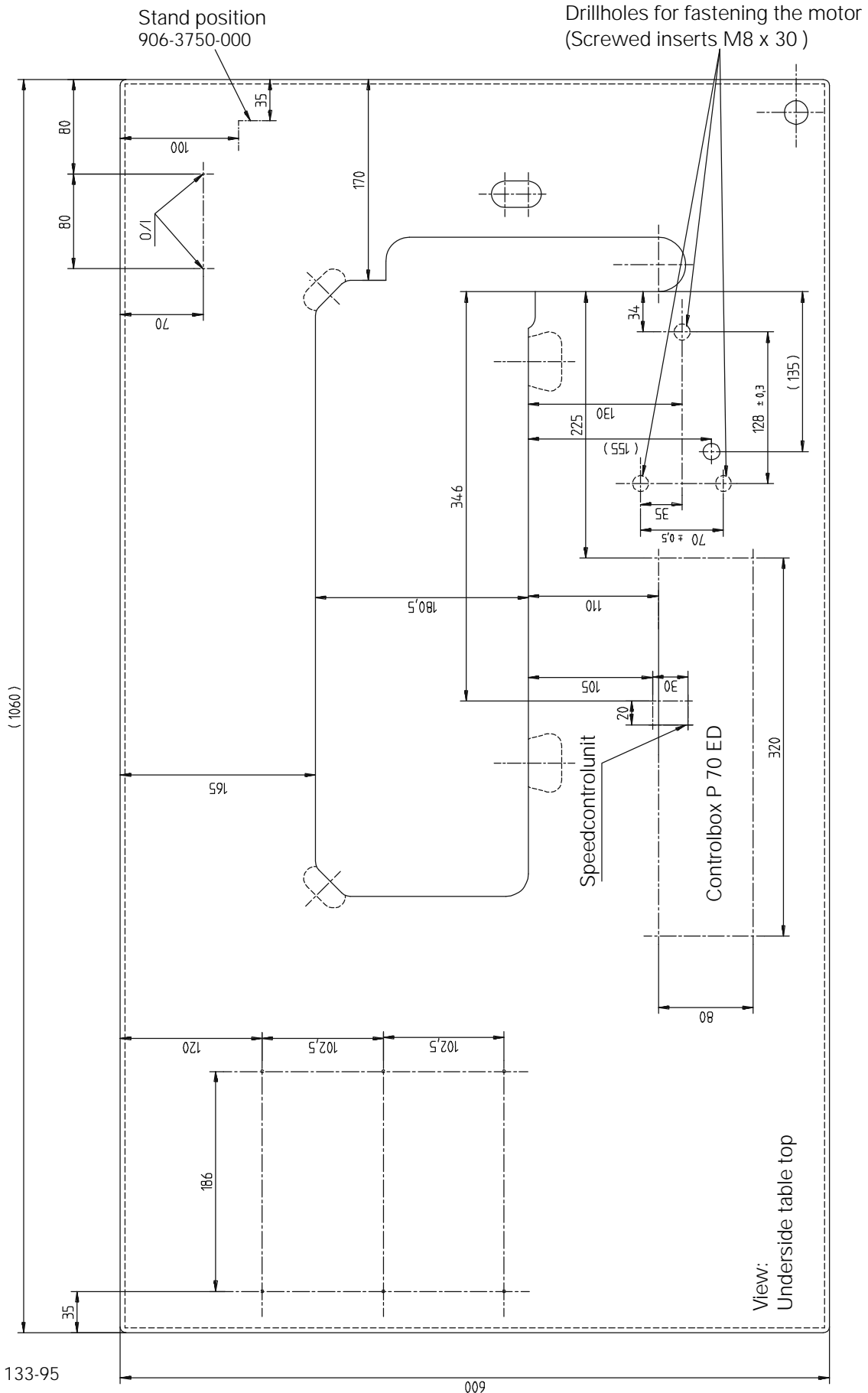

91-280 133-95

009

## 11.03 Mounting the table top (with Quick-PicoDrive and control unit P41 PD-L)

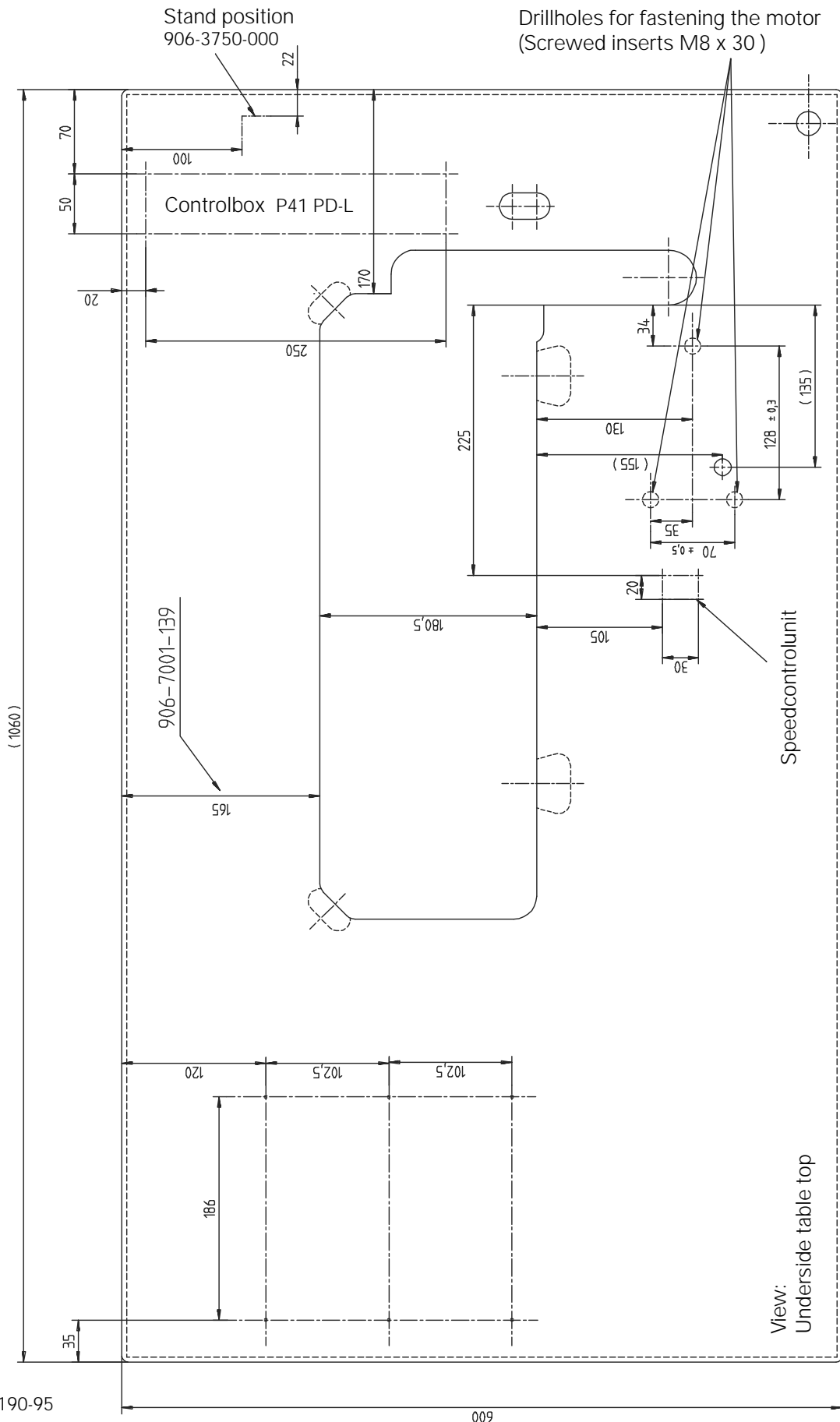

### 11.04 Circuit diagrams (with Quick-EcoDrive and control unit P 70 EDx)

#### Reference list for the Circuit diagrams

|      |   |
|------|---|
| A1   | Control unit Quick P70 ED                       |
| A2   | Control panel S2                                |
| A14  | Sewing head recognition system (OTE)            |
| H1   | Sewing lamp                                     |
| H8   | -926/07 LED stitch counting                     |
| M1   | Sewing motor                                    |
| Q1   | Main switch                                     |
| S1.1 | Pedal speed control unit                        |
| S1   | Key 1 other function depending on parameter     |
| S2   | Key 2 other function depending on parameter     |
| S3   | Key 3 other function depending on parameter     |
| S4   | Key 4 other function depending on parameter     |
| S5   | Key 5 other function depending on parameter     |
| S6   | Key 6 other function depending on parameter     |
| S7   | Key 7 other function depending on parameter     |
| S13  | Speed 1   |
| S15  | Speed 2   |
| S17  | Knee switch lift adjustment                     |
| V1   | LED 1 (2) other function depending on parameter |
| V2   | LED 2 (3) other function depending on parameter |
| V3   | LED 3 (4) other function depending on parameter |
| V4   | LED 4 (5) other function depending on parameter |
| V5   | LED 5 (6) other function depending on parameter |
| V6   | LED 6 (7) other function depending on parameter |
| V7   | LED 7 (1) other function depending on parameter |
| X0   | PC-interface (RS 232)                           |
| X1   | Sewing motor                                    |
| X1B  | A14 Sewing head recognition                     |
| X2   | Incremental transducer                          |
| X2.1 | Incremental transducer                          |
| X2.2 | Synchronizer PD 3                               |
| X2B  | S2 control panel                                |
| X3   | Speed control unit                              |
| X7   | Light barrier plug (optional))                  |

|       |   |
|-------|---|
| X11   | Bobbin thread monitor (optional)                                  |
| X12   | Plug key row  |
| X13   | Output-input plug 1   |
| X14   | Output-input plug 2   |
| XH8   | -926/07 reverse stitch counting                                   |
| XY2   | -900/.. thread trimmer  |
| XY2.1 | -900/82 short thread trimmer                                      |
| XY3   | -909/.. thread wiper  |
| XY4   | -910/.. automatic foot lift                                       |
| XY5   | -911/.. backtacking device  |
| XY6   | -918/.. lift adjustment or -720/.. right needle                   |
| XY9   | -918/.. second top stitch length or -720/.. left needle           |
| XY10  | Thread tension release  |
| XY12  | -918/.. second bottom stitch length                               |
| XY13  | -748/.. lift puller   |
| XY14  | Thread tension switchover (optional)                              |
| XY15  | -748/.. lift puller on automatic foot lift and backtacking device |
| XY37  | Oil valve open while machine running                              |
| XY38  | Clean hook X11 bobbin thread monitor (optional)                   |
| Y2    | -900/.. thread trimmer  |
| Y2.1  | -900/82 thread trimmer  |
| Y3    | -909/.. thread wiper  |
| Y4    | -910/.. automatic foot lift                                       |
| Y5    | -911/.. backtacking device  |
| Y6    | -918/.. lift adjustment or -720/.. right needle                   |
| Y9    | -918/.. second top stitch length or -720/.. left needle           |
| Y10   | Thread tension release  |
| Y12   | -918/.. second bottom stitch length                               |
| Y13   | -748/.. lift puller   |
| Y14   | Zero stitch - cut (optional)                                      |
| Y15   | -748/.. lift puller on automatic foot lift and backtacking device |
| Y37   | Oil valve open while machine running                              |
| Y38   | Clean hook X11 bobbin thread monitor (optional)                   |

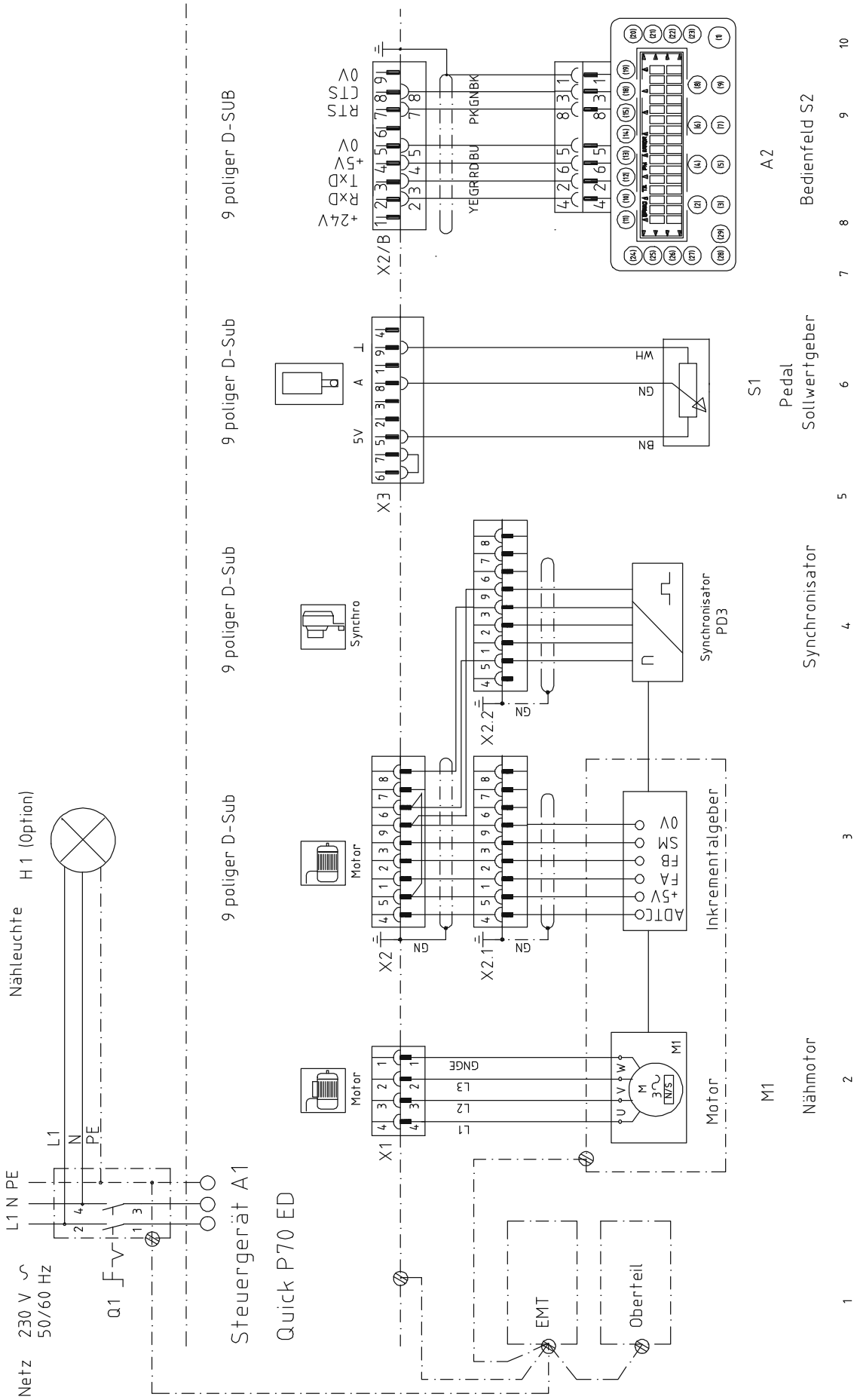

- 1 Nähmotor
- 2 M1
- 3 Inkrementalgeber
- 4 Synchronisator PD3
- 5 Synchronisator
- 6 Pedal Sollwertgeber
- 7 S1
- 8 Bedienfeld S2
- 9 A2
- 10

Ausgänge und Eingänge Steuergerät A1 Quick P70 ED

37 poliger D-Sub

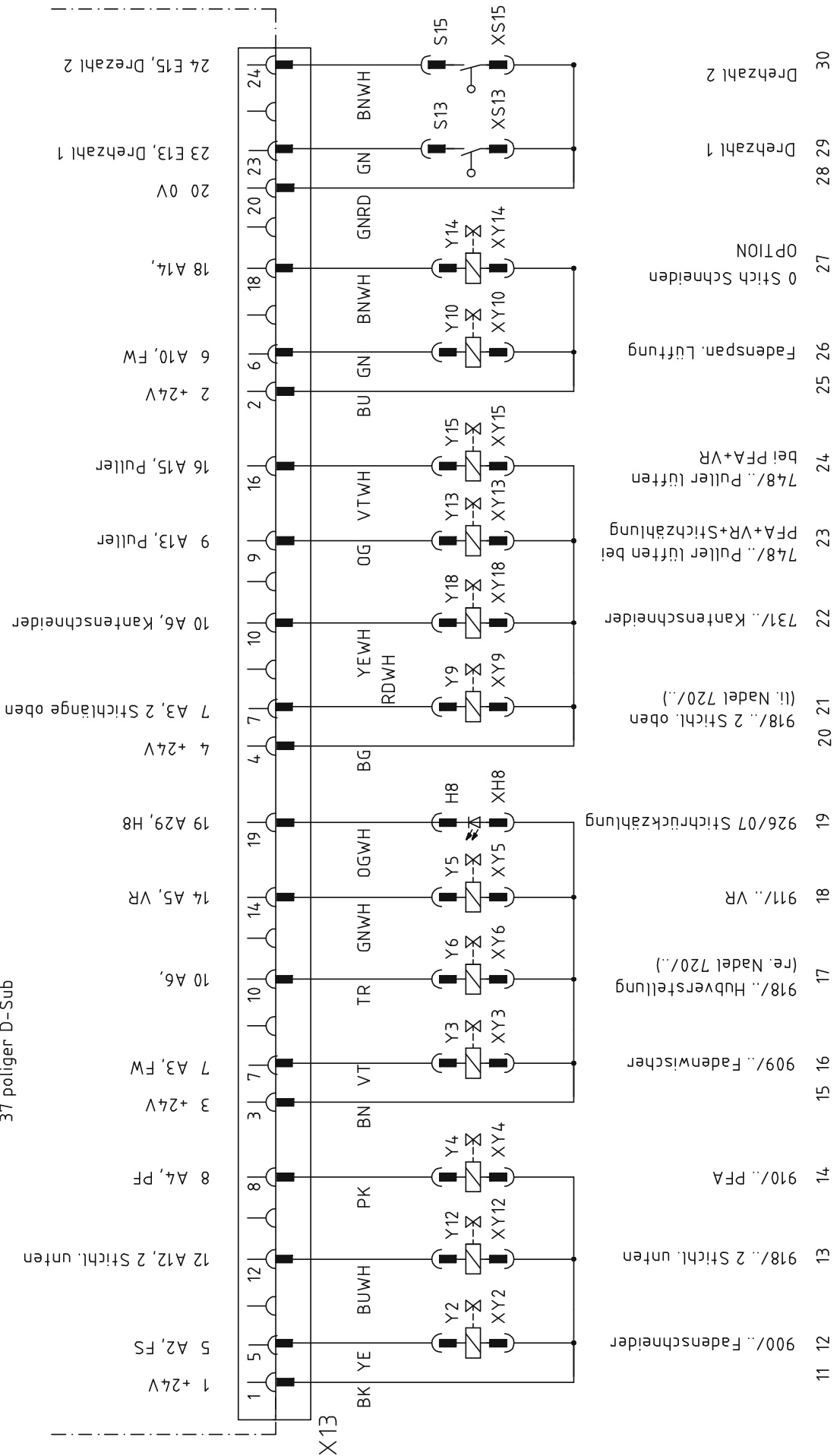

Steuergerät A1 Quick P70 ED

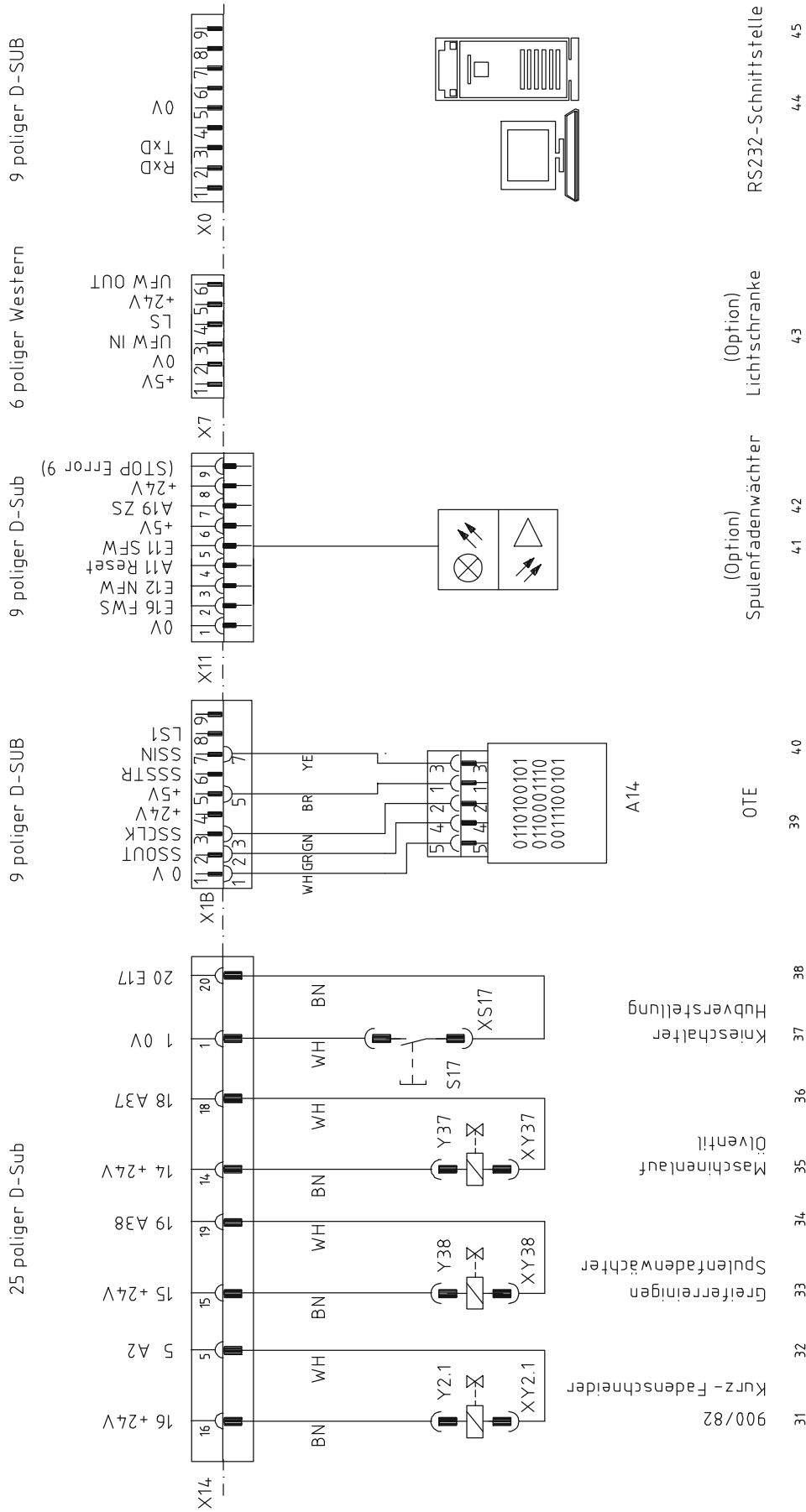



Steuergerät A1 Quick P70 ED

15pol. SUB-D  
Tastenreihe

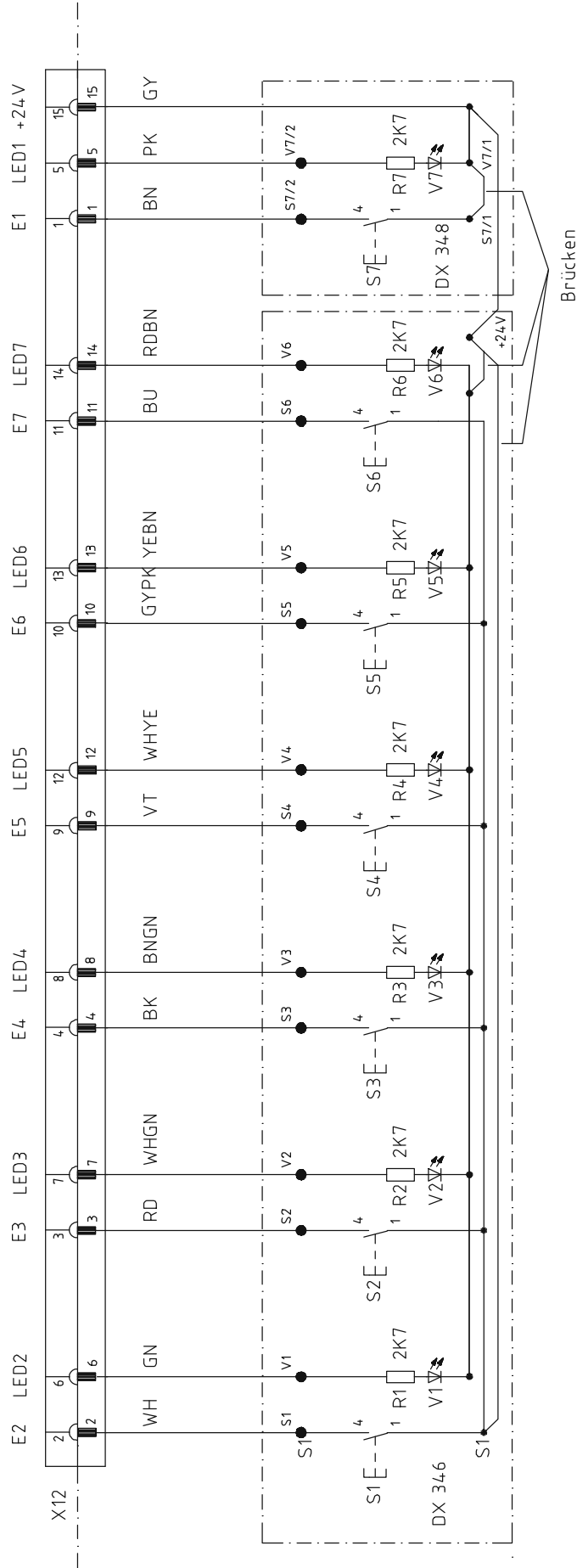

Tastenreihe KL 1520

46 47 48 49 50 51 52 53 54 55 56 57 58 59 60

11.05 Block diagram PFAFF 1525 S with control unit P41 PD-L

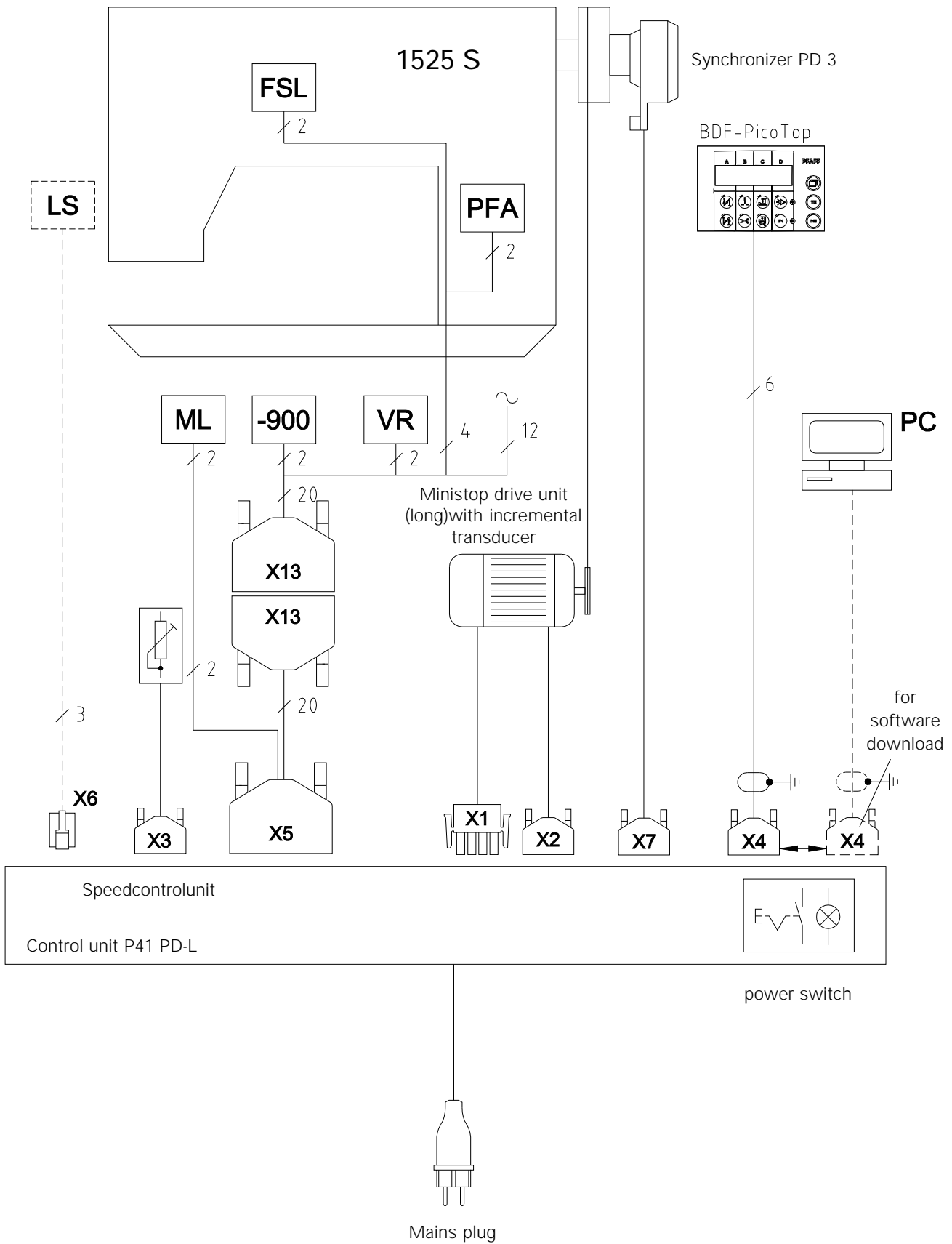

**11.06 Circuit diagrams** (with Quick-PiccoDrive and control unit P41 PD-L)**Reference list for the Circuit diagrams 91-191 518-95**

|     |  |
|-----|--|
| A1  | Control unit Quick P41PD-L                         |
| A2  | Control panel Pico-Top                             |
| HQ1 | Main switch-lamp                                   |
| M1  | Sewing motor with incremental transmitter          |
| Q1  | Main switch  |
| S1  | Pedal speed control unit                           |
| X1  | M1 Sewing motor                                    |
| X2  | M1 Incremental transducer                          |
| X3  | S1 Speedcontrolunit                                |
| X4  | A2 Control panel Pico-Top or PC-interface (RS 232) |
| X5  | Output-input plug                                  |
| X8  | Light barrier plug (optional)                      |
| X9  | Synchronizer PD 3                                  |
| X13 | Adapter lead plug                                  |
| XY1 | -910/.. automatic foot lift                        |
| XY2 | -911/.. backtacking device                         |
| XY3 | Lubrication hook (ML)                              |
| XY4 | Thread tension release FSL                         |
| XY5 | -900/.. thread trimmer                             |
| Y1  | -910/.. automatic foot lift                        |
| Y2  | -911/.. backtacking device                         |
| Y3  | Lubrication hook (ML)                              |
| Y4  | Thread tension release (FSL)                       |
| Y5  | -900/.. thread trimmer                             |

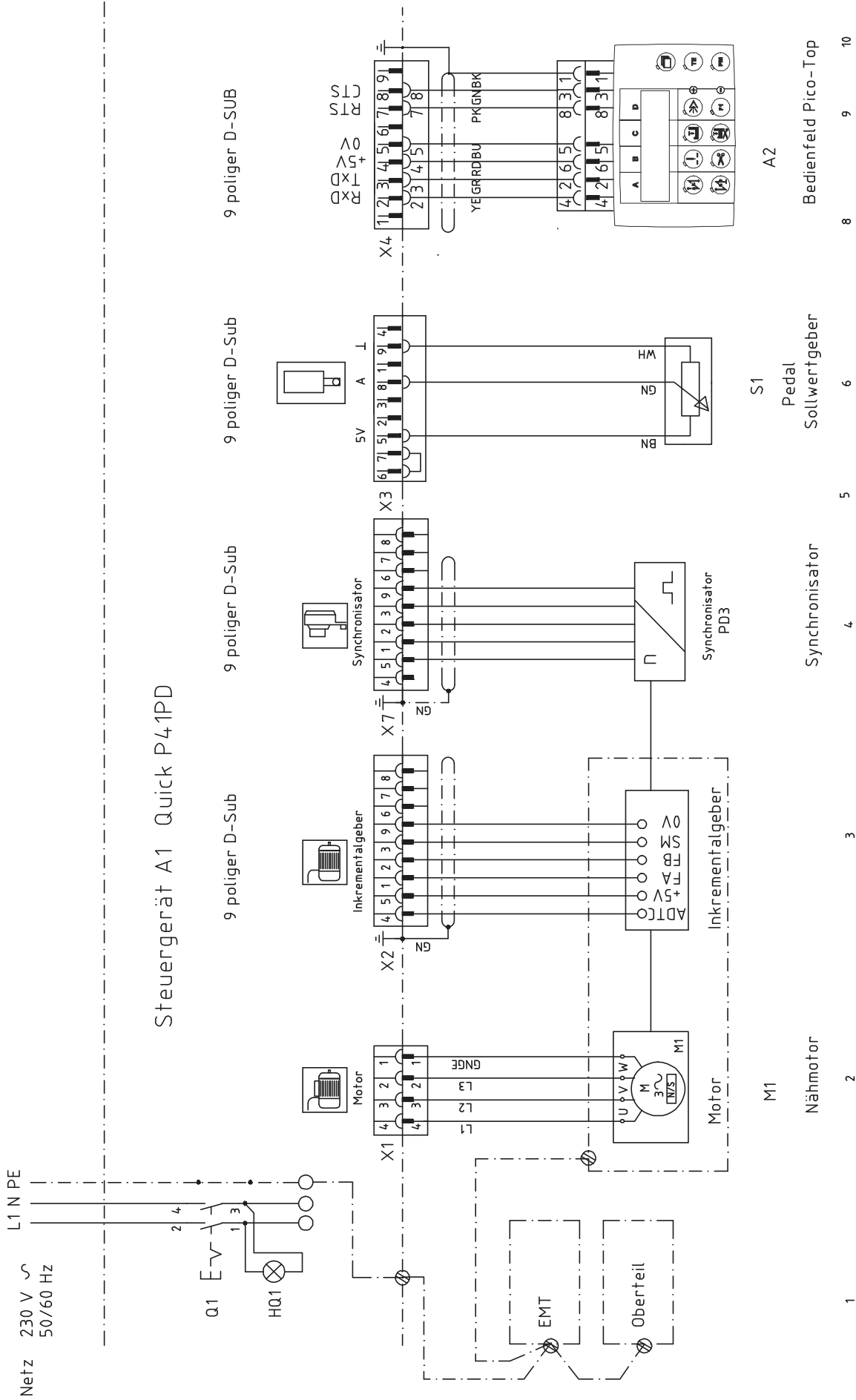

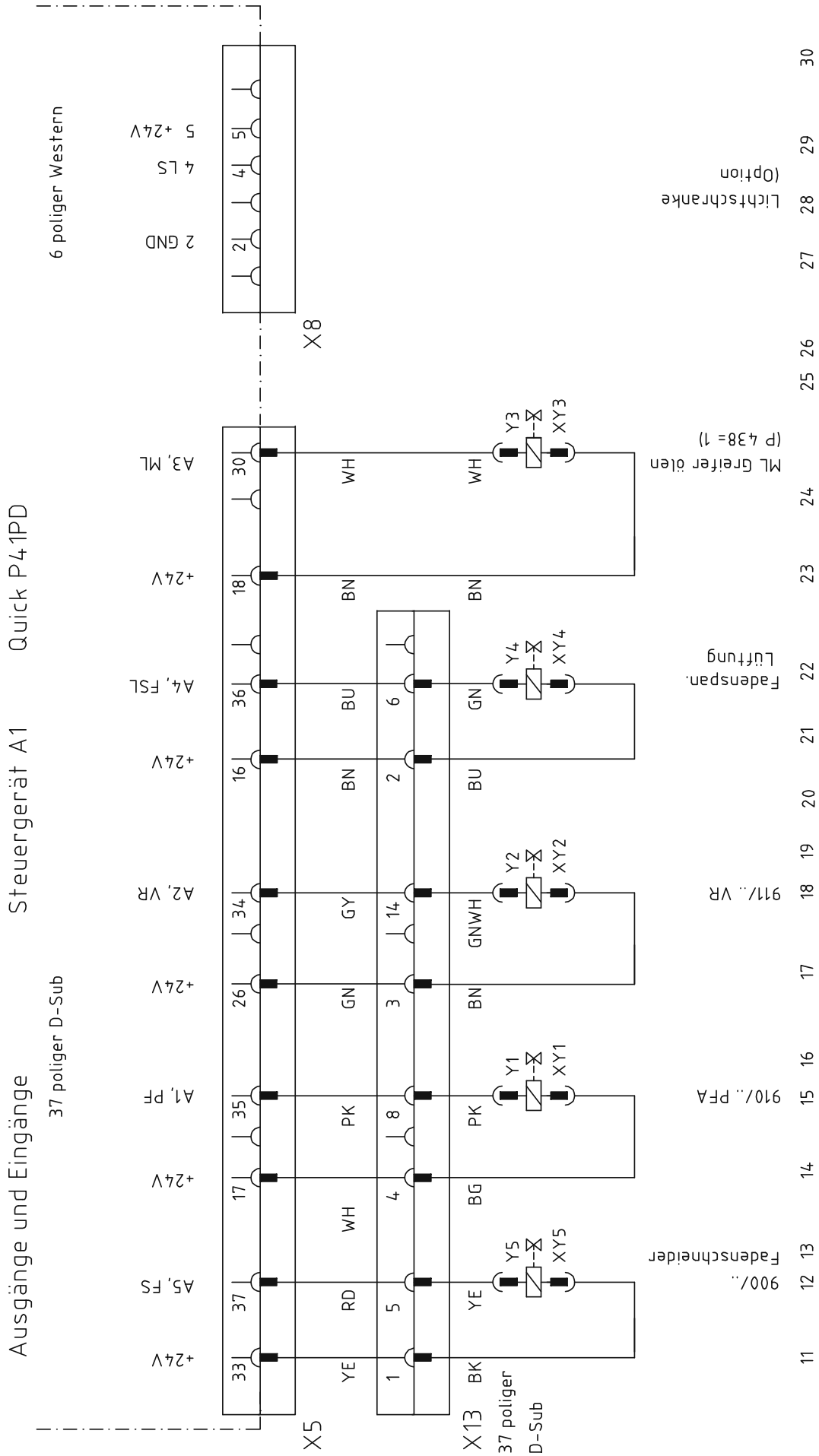

mit Adapterleitung  
Nr. 91-292 321-91



This is a list of the most important wearing parts.

A detailed parts list for the complete machine is included with the accessories.

In case of loss, the parts list can be downloaded from the internet address [www.pfaff-industrial.com/pfaff/de/service/downloads](http://www.pfaff-industrial.com/pfaff/de/service/downloads) As an alternative to the internet download the parts lists can also be ordered in book form under part no. 296-12-18 596.

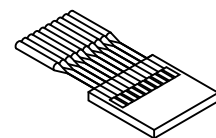
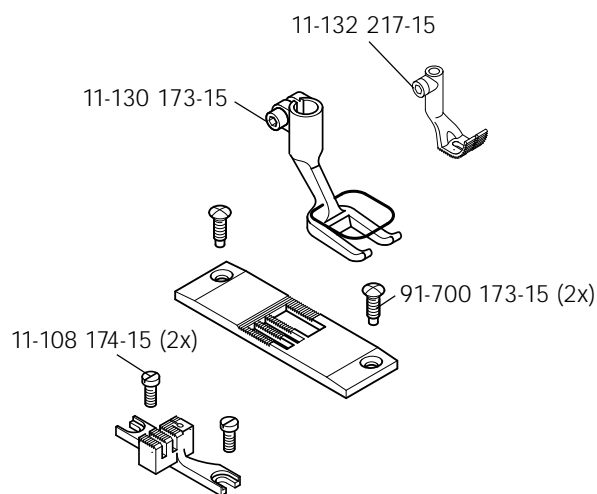
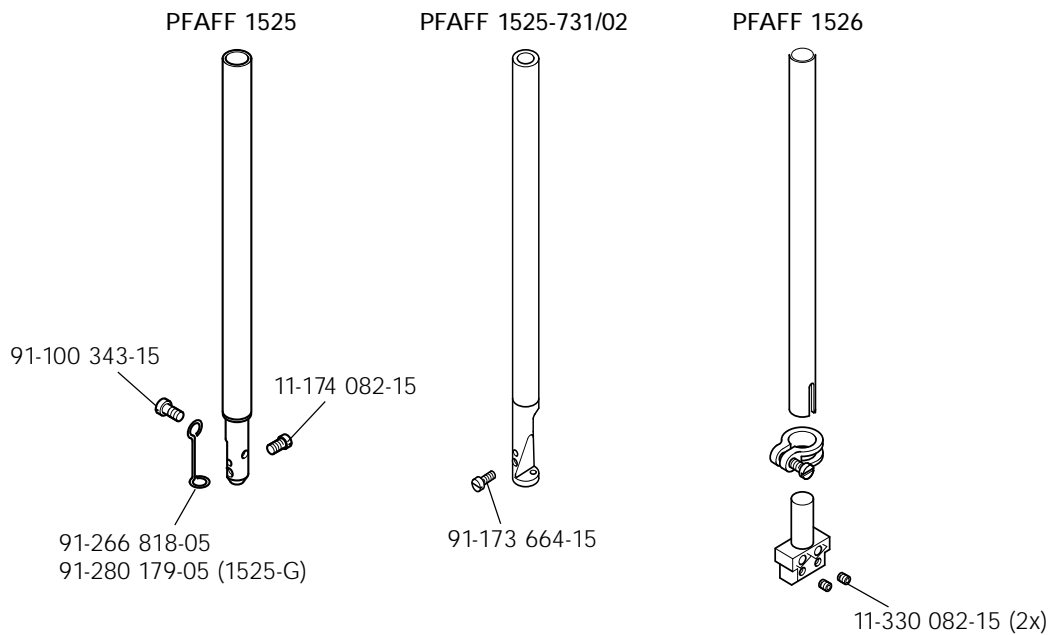

System 134-35

91-266 504-91 (1525; 1525-S)

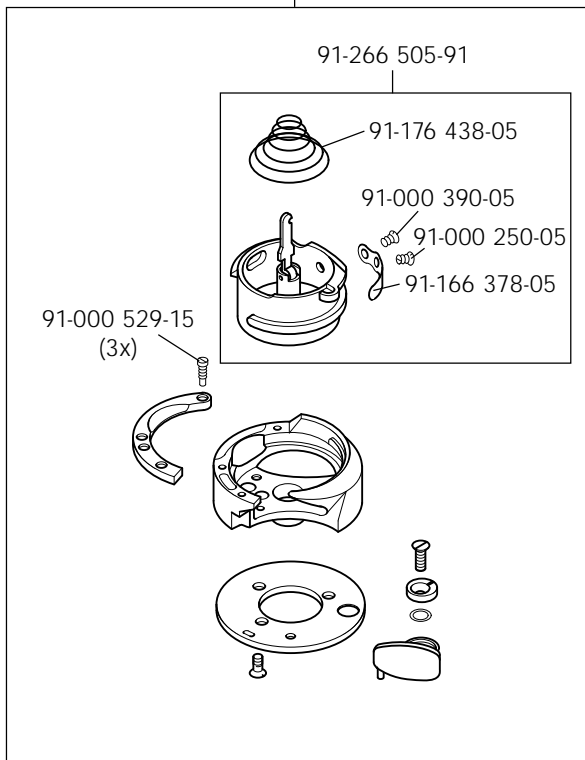

91-266 685-91 (1525; 1525-S)

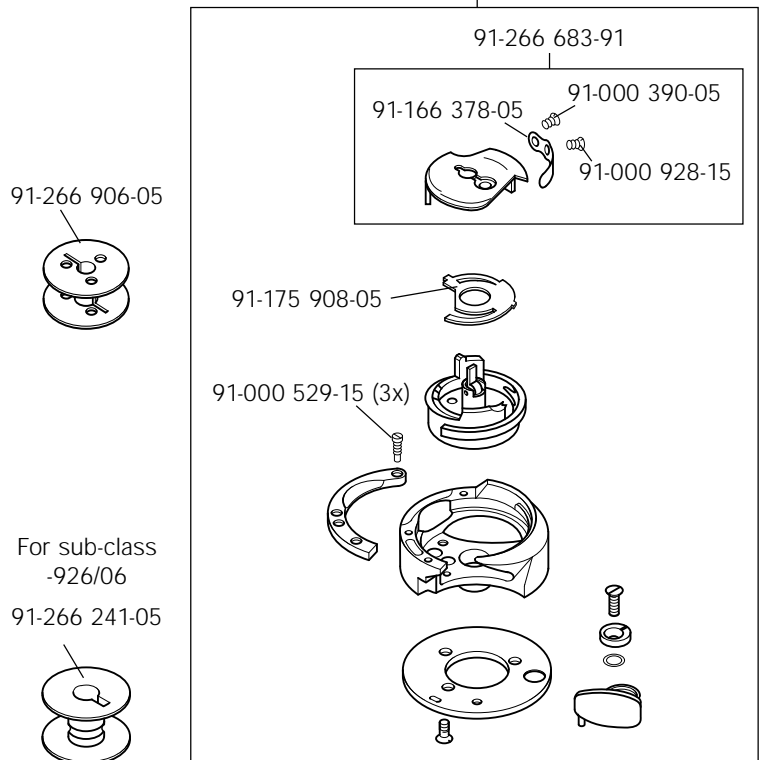

91-280 140-91 (1525-G)

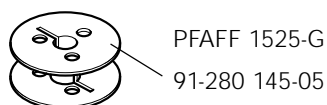
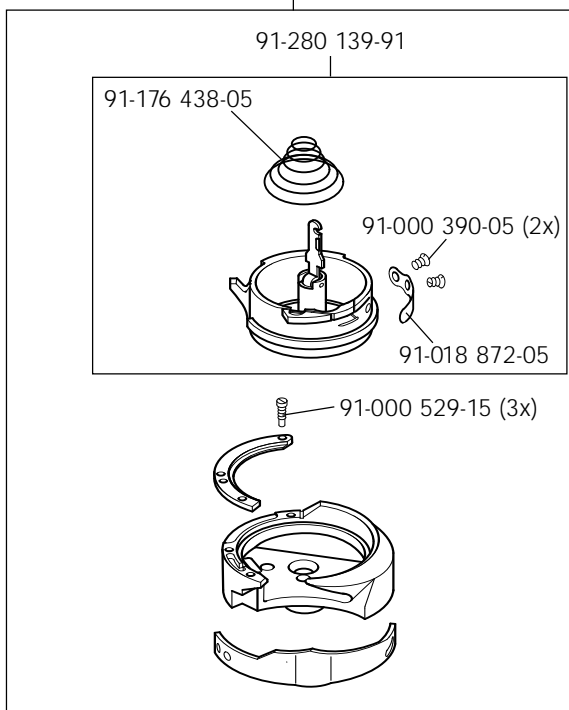

-900/81

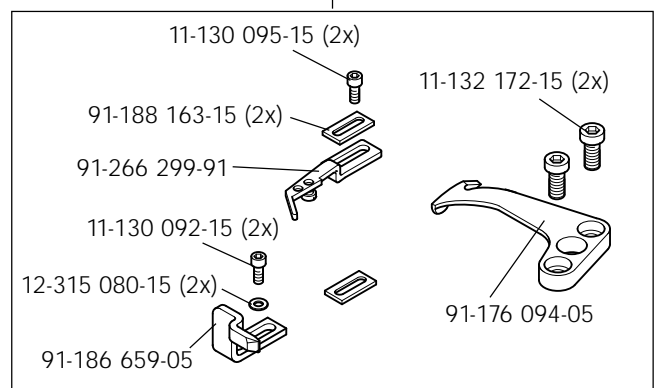

-900/82

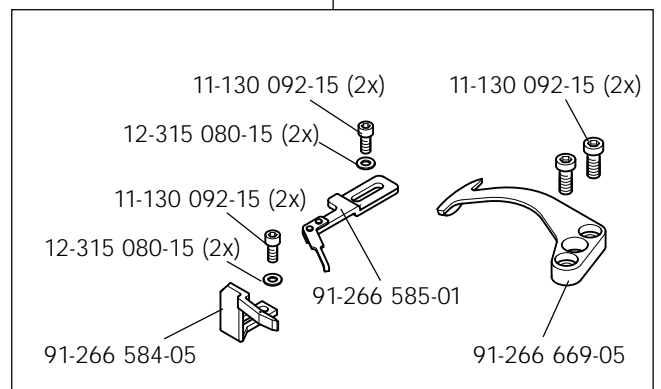

# Wearing parts

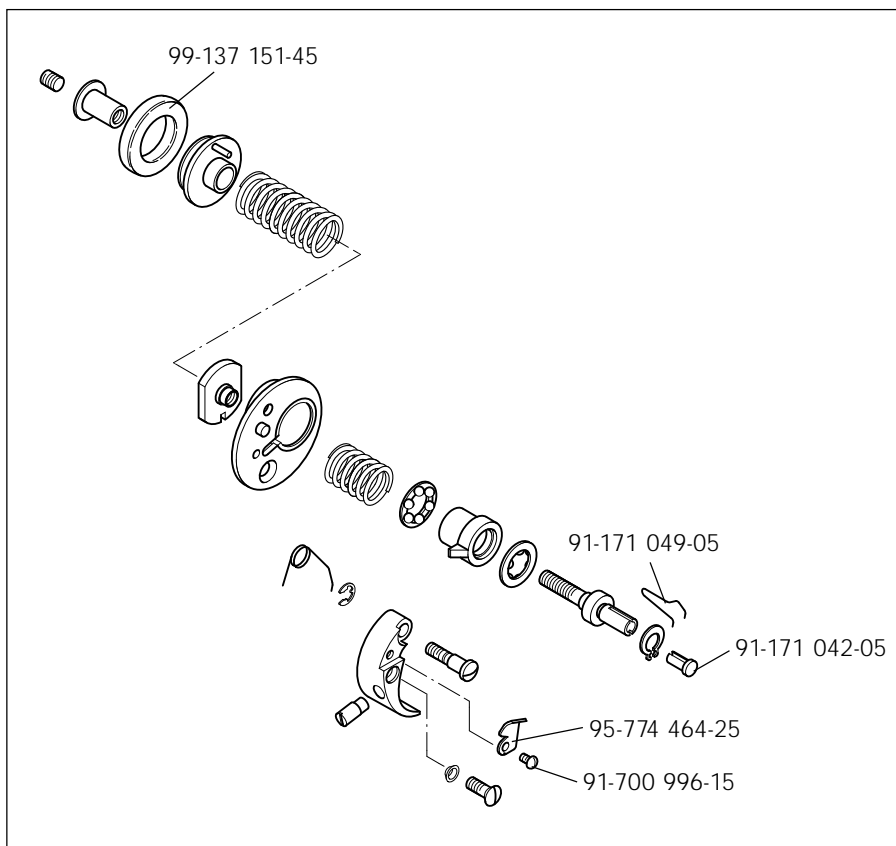
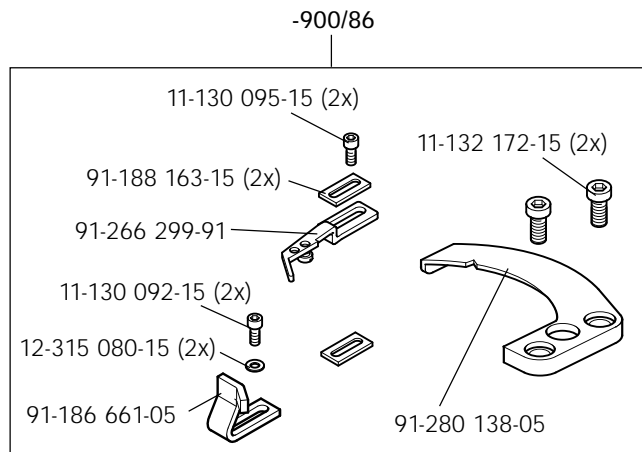

PFAFF 1525

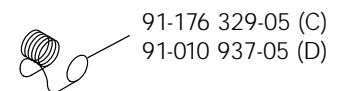

PFAFF 1526

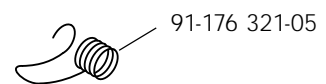

For sub-class -731/02

Cutting depth 2,5 - 4,9 mm

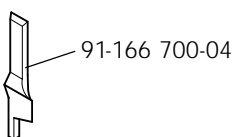

Cutting depth 5,0 - 8,0 mm

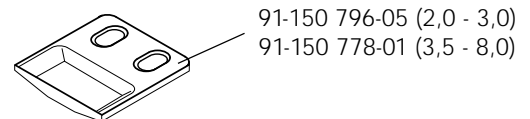
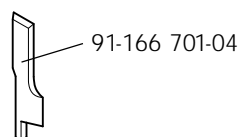







**Europäische Union**  
Wachstum durch Innovation – EFRE



## PFAFF Industriesysteme und Maschinen AG

Hans-Geiger-Str. 12 - IG Nord  
D-67661 Kaiserslautern

Phone: +49-6301 3205 - 0  
Fax: +49-6301 3205 1386  
E-mail: [info@pfaff-industrial.com](mailto:info@pfaff-industrial.com)

### Hotlines:

Technical service: +49-175/2243-101  
Application consultancy: +49-175/2243-102  
Spare-parts hotline: +49-175/2243-103

Printed in Germany