

***POWER*Line**

2231

2235

SET-UP INSTRUCTIONS

2545

2546

The reprinting, copying or translation of PFAFF Service Manuals - whether in whole or in part - is only permitted with our prior consent and with reference to the source.

**PFAFF Industriesysteme
und Maschinen AG**

Hans-Geiger-Str. 12 - IG Nord
D-67661 Kaiserslautern

Contents		Page
1	General Notes	4
1.01	Explanation of the symbols.....	4
2	Scope of delivery	5
2.01	Sewing machine accessories	5
2.02	Accessories for the sewing machine drive with PicoDrive P45 PD2-L	7
2.03	Accessories for the sewing machine drive with EcoDrive P74 ED-L.....	8
3	Stand and table top	10
3.01	Table top cutout	10
3.02	Assembly drawing for the table top (for machines with P45 / P74)	11
3.03	Assembling the stand and table top	12
3.04	Adjusting the table-top height.....	13
4	Assembling the sewing machine drive	14
4.01	Assembling the EcoDrive or PicoDrive motor.....	14
4.02	Assembling the PicoDrive control unit P45 PD2-L and motor	15
4.03	Assembling the EcoDrive control unit P74 ED-L and motor.....	16
5	LED-Lamp (optional).....	17
5.01	Assembling the LED lamp	17
5.02	Fitting the transformer to the LED lamp	18
6	Installation	19
6.01	Setting the sewing machine into the stand	19
6.02	Fitting the V-belt and assembling the bottom belt guard.....	20
6.03	Assembling the thread guide and take-up lever guard.....	21
6.04	Assembling the top V-belt guard and sewing head support.....	22
6.05	Mounting the control panel.....	23
6.06	Connecting the plug-in connections and earth cables	24
6.07	Block diagram	25
6.07.01	PFAFF 2231 and 2235 with PicoDrive P45 PD2-L.....	25
6.07.02	PFAFF 2235 and 2545/46 with EcoDrive P74 ED-L.....	26
6.07.03	PFAFF 2545/46 BASIC with PicoDrive P45 PD2-L.....	27
6.08	Mounting / connecting the maintenance unit.....	28
7	Commissioning	29
7.01	Switching the machine on/off	29
7.02	Basic position of the machine drive	30

1 General Notes



The machine may only be set-up and commissioned by qualified personnel!
All notes in Chapter 1 Safety of the Instruction Manual must be observed!



There must be suitable electrical connections at set-up site, see Chapter 3 Specifications of the Instruction Manual. A firm, level surface and adequate lighting must also be available at the set-up site.



If the machine was delivered without a table, both the stand and the table top intended for use must be constructed for a weight of at least **100 kilos**.

1.01 Explanation of the symbols

In these Set-Up Instructions, symbols emphasize operations to be carried out or important information. The symbols used have the following meaning:



Note, information

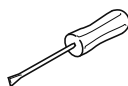

Service, repair, adjustment, maintenance
(work to be carried out by qualified staff only)

Safety symbols



Danger!
Points to be observed.



Danger of injury for operating and specialist personnel!



2 Scope of delivery

The scope of delivery of the machine **depends on the order**.

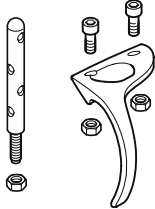
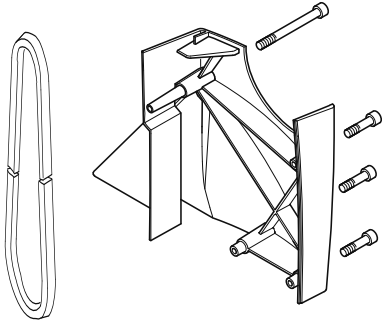

Before setting up the machine, check whether all the required parts have been included.

The following description only applies to one special sewing machine, for which all individual components have been delivered by the PFAFF Industriesysteme und Maschinen AG.

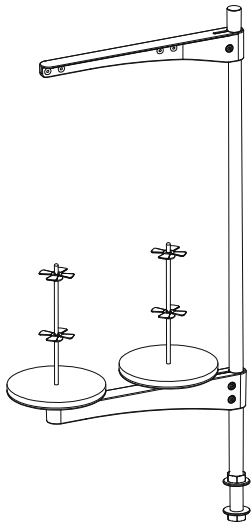
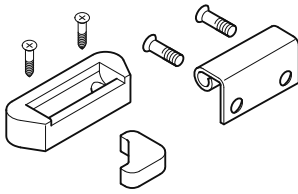
2.01 Sewing machine accessories

Sewing machine accessories	Description / No. of pieces
	Thread guide and take-up lever guard with screws and nuts (1x)
	V-belt and belt guard with screws (1x)
	Bobbin (5x)
	Reel stand complete (1x)
	Rear rubber pads with screws (2x) Front rubber pads (2x) Hinge with screws (2x)

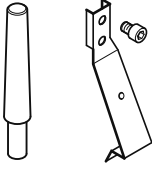
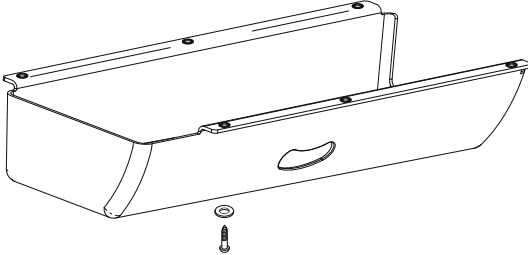
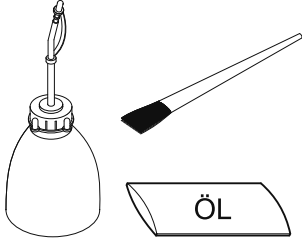
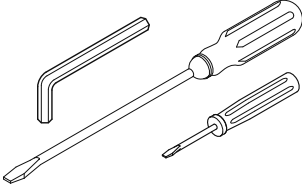
Scope of delivery

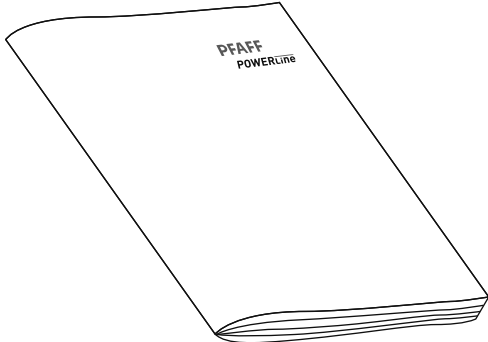
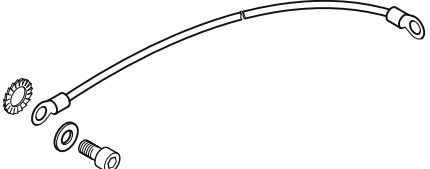
Sewing machine accessories	Description / No. of pieces
	<p>Sewing head support (1x), Tilt lock (1x) (only on the PFAFF 2545 and 2545)</p>
	<p>Oil pan with 6 screws and washers</p>
	<p>Oilcan (1x), Sachet with 80 ml oil, Dusting brush (1x)</p>
	<p>Allan key 3 mm (1x), Screwdriver large (1x), Screwdriver small (1x)</p>
	<p>Sewing head protective cover</p>
	<p>Set-up instructions, instruction manual for the machine</p>
	<p>Earth cable 2231 + 2235 (2x), 2545 (3x) , Screw and washers</p>

2.02 Accessories for the sewing machine drive with PicoDrive P45 PD2-L

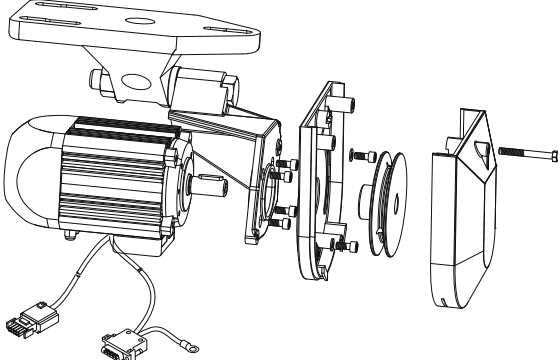
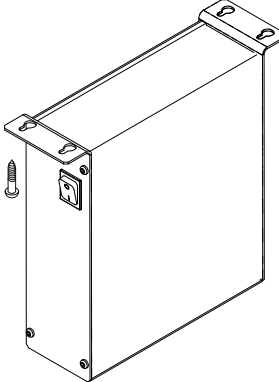
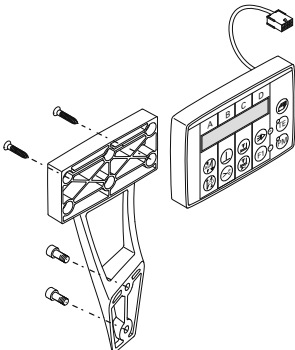
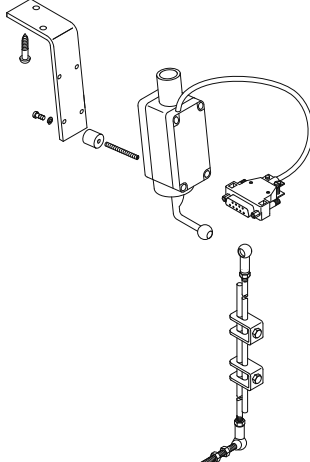
Control package PicoDrive P45 PD2-L	Description
	<p>Motor mounting with motor and fastening screws</p>
	<p>Control box with fastening screws</p>
	<p>Control panel bracket with control panel and fastening screws</p>
	<p>Speed control unit with holder and fastening screws, and connecting rod to the pedal</p>

Scope of delivery

2.03

Accessories for the sewing machine drive with EcoDrive P74 ED-L

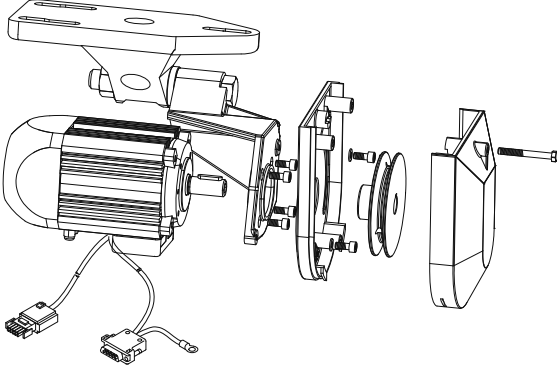
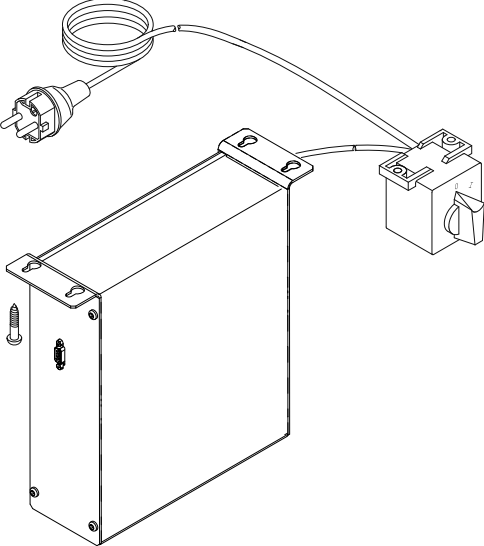
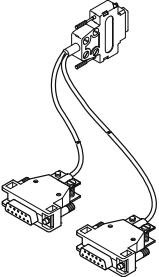
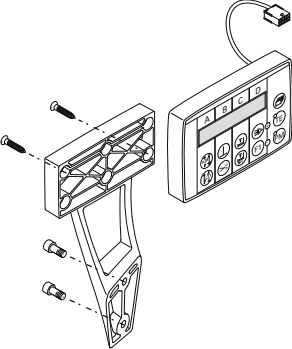
Control package EcoDrive P74 ED-L	Description
	Motor mounting with motor and fastening screws
	Control box with switch, fastening screws and cable
	Adapter cable for synchronizer
	Control panel bracket with control panel and fastening screws

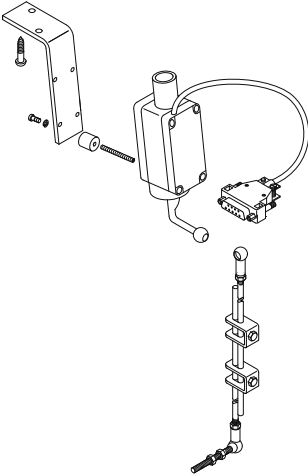
Control package EcoDrive P74 ED-L	Description
	<p>Speed control unit with holder and fastening screws, and connecting rod to the pedall</p>

Stand and table top

3 Stand and table top

3.01 Table top cutout

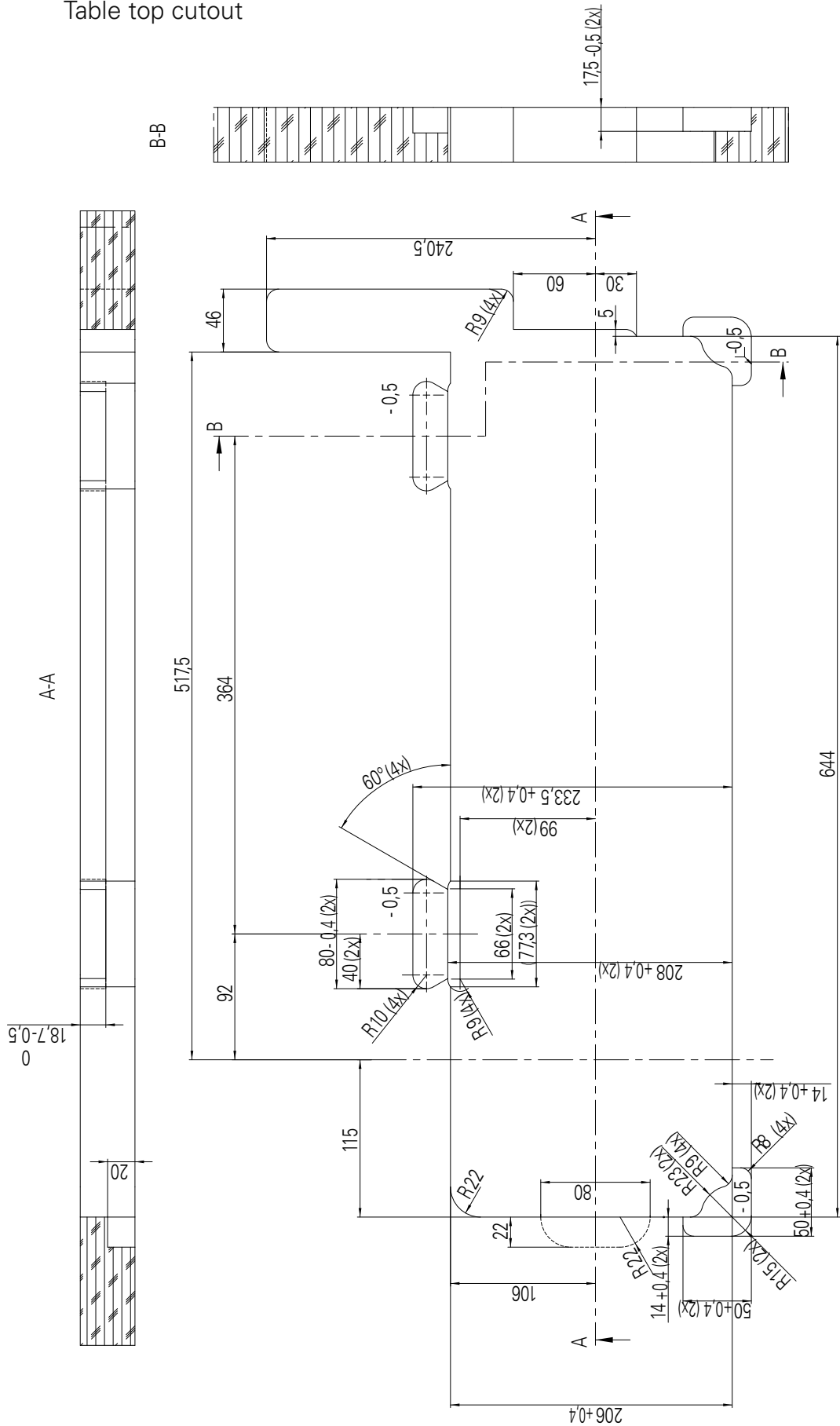

3.02 Assembly drawing for the table top (for machines with P45 / P74)

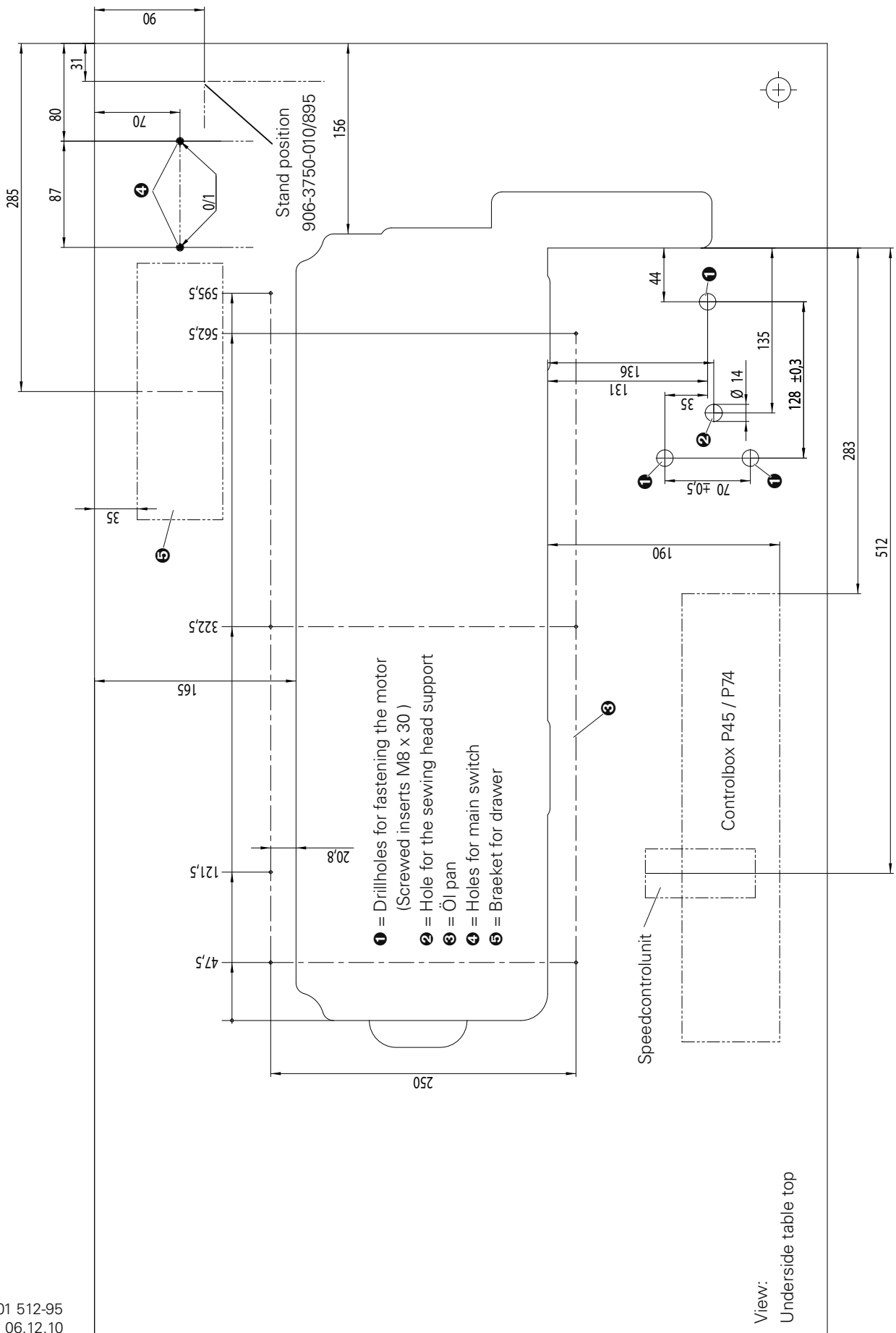

Stand and table top

3.03 Assembling the stand and table top

- Assemble the stand (part no. 906-3750-010/895) and table top as shown in the following illustration.



The stand and table top must be constructed for a weight of at least **100 kg**.

- When assembling the table top, please observe the assembly drawing (Chapter 3.02).

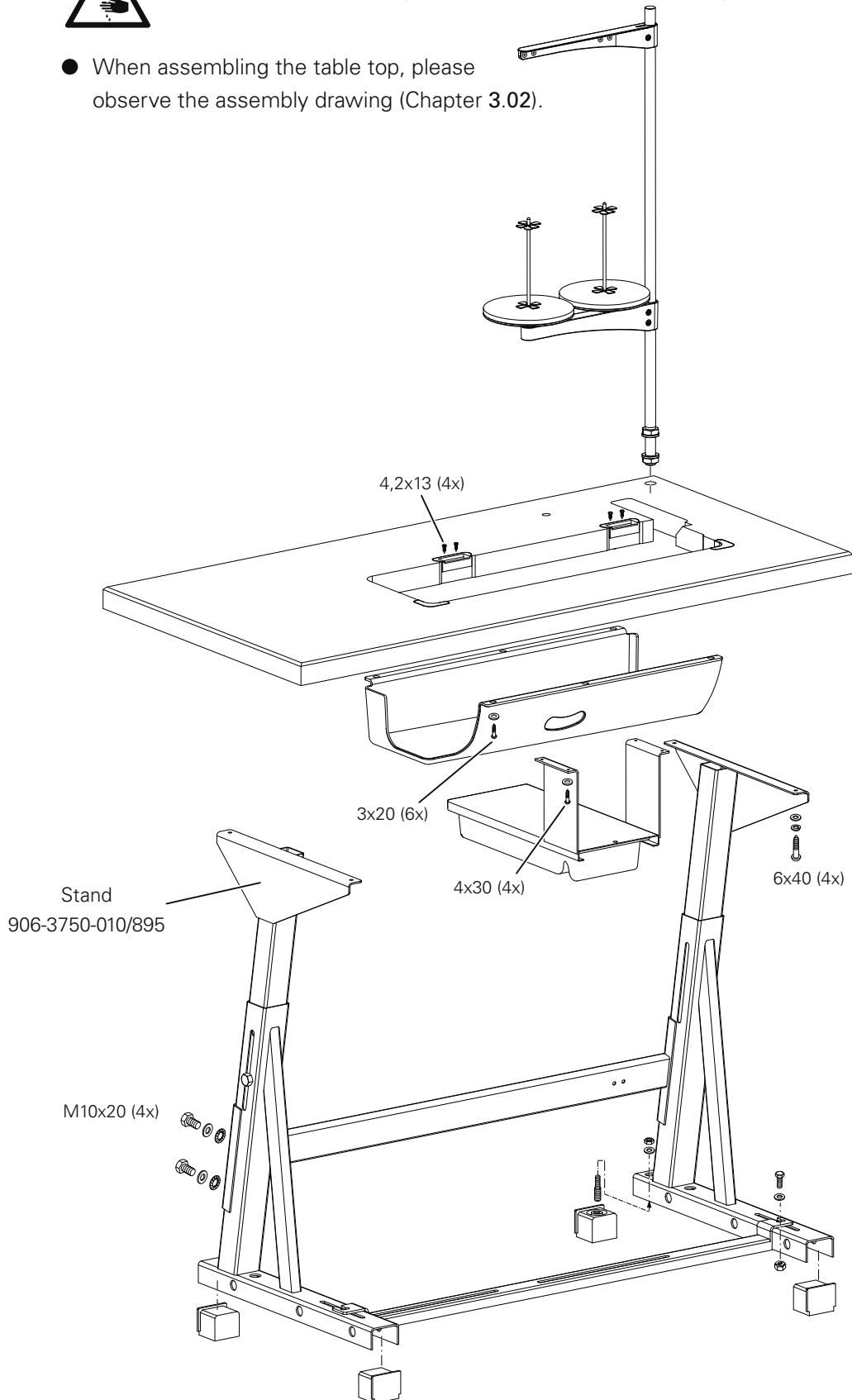
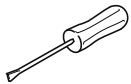
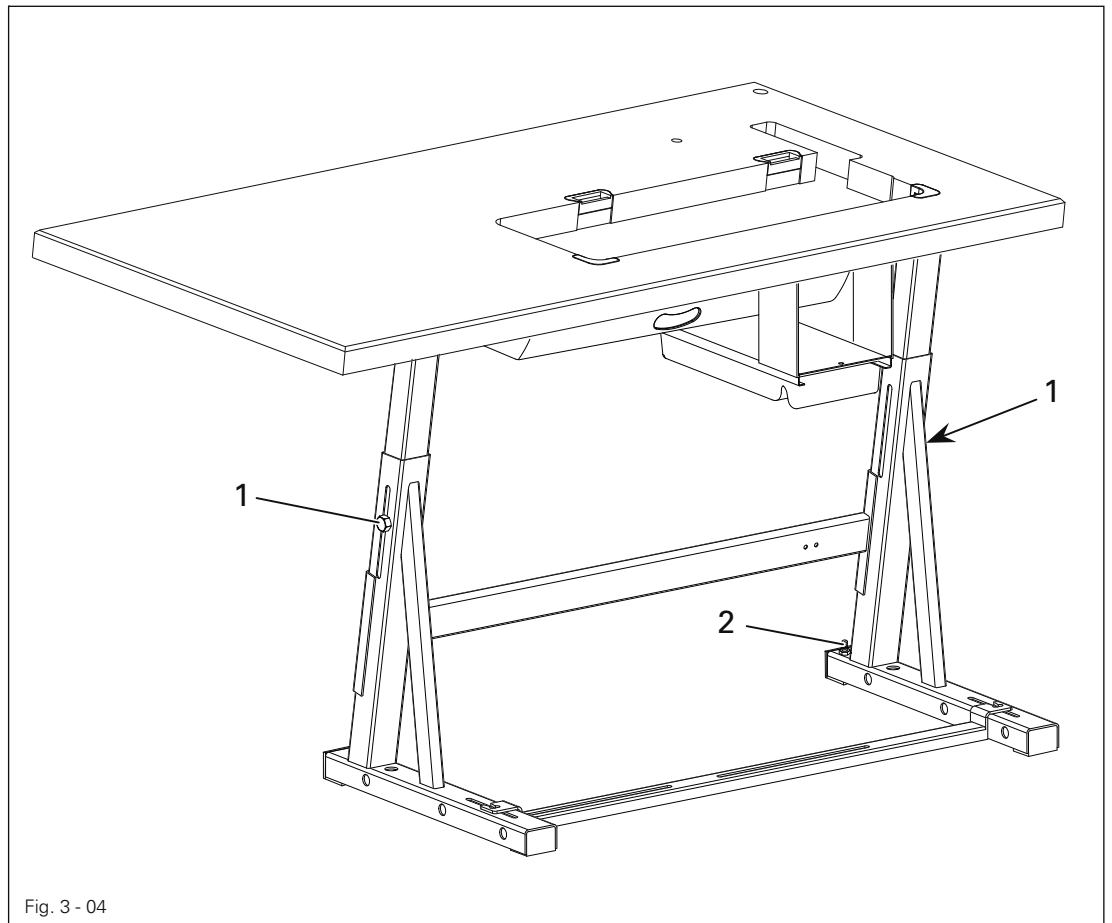

Fig. 3- 03

3.04 Adjusting the table-top height



- Loosen screw 1.
- Adjust the table top to the required working height by increasing or reducing the height of the stand and then level the table-top horizontally.



To avoid the stand tilting, adjust it evenly on both sides.

- To guarantee that the stand is standing securely, it must be positioned securely on the ground with all four legs.
- The height can be adjusted with screw 2.

4 Assembling the sewing machine drive

4.01 Assembling the EcoDrive or PicoDrive motor

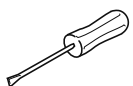
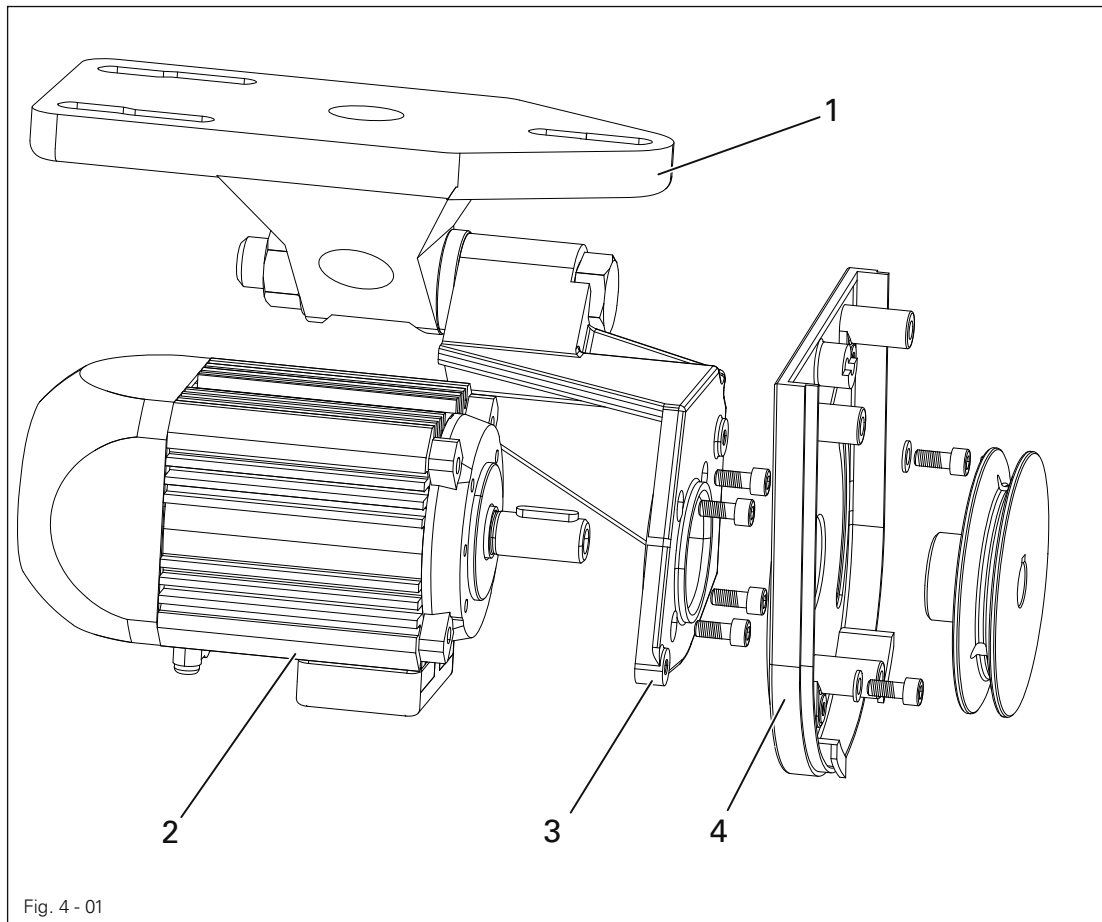

- Assemble motor mounting 1, motor 2, belt guard support 3 and belt pulley 4 as shown in Fig. 4-01.

4.02 Assembling the PicoDrive control unit P45 PD2-L and motor

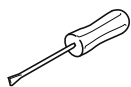
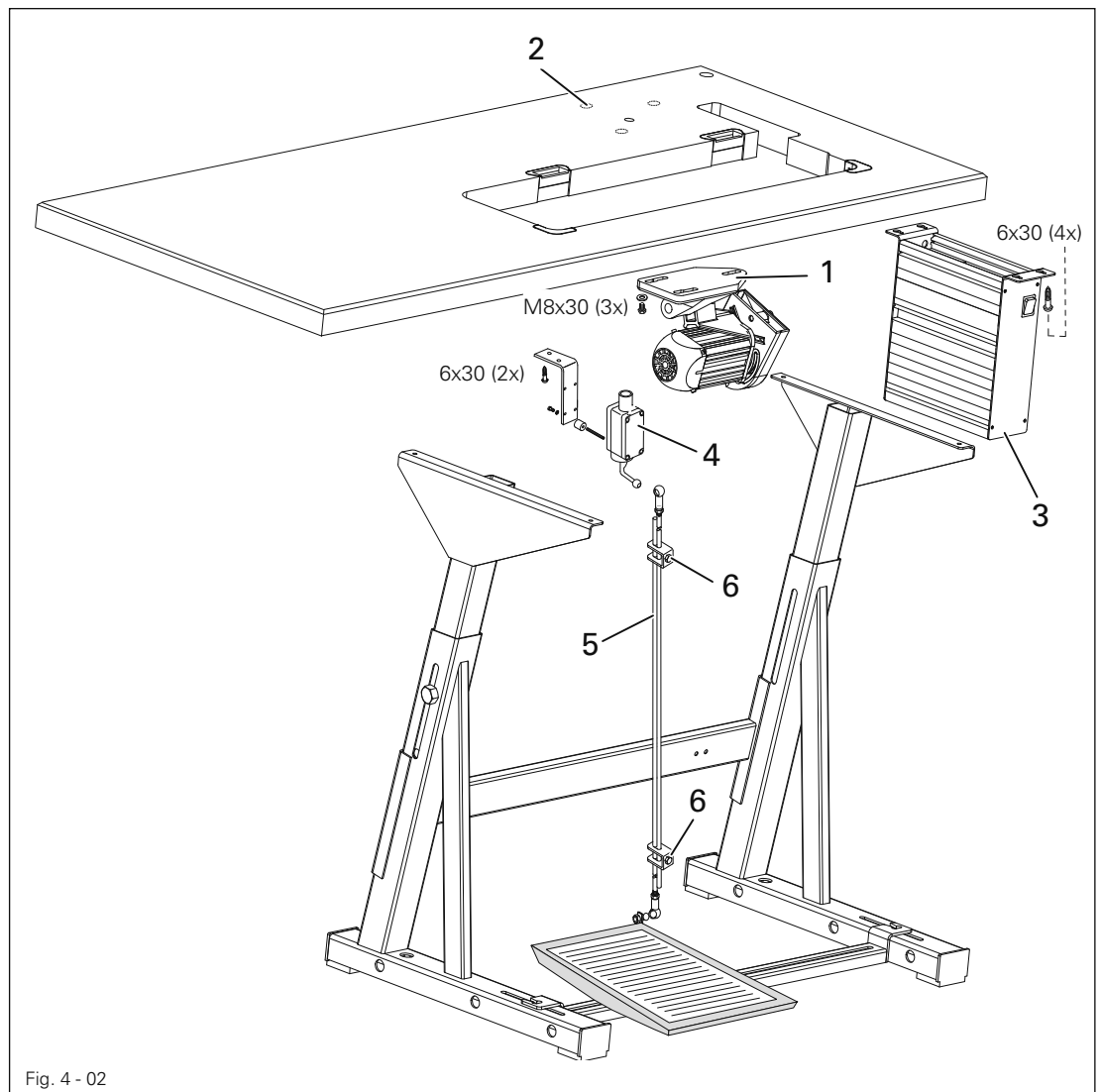

- Fasten the motor mounting 1 with motor to the screwed inserts 2 of the table top with three hexagon bolts M8 x 30.
- Fit the control box 3 to the table top with four screws 6x30.
- Screw the mains cable of the control box 3 to the table top with a mains lead cleat.
- Assemble the speed control unit 4 and attach it to the table top with two screws 6x30.
- Mount the pedal on the stand's cross-bar, aligning the middle of the pedal with the centre of the needle.
- Fit connection rod 5 to speed control unit 4 and to the pedal.
- The slant of the pedal can be adjusted after loosening screw 6 (slant angle approx. 10°).

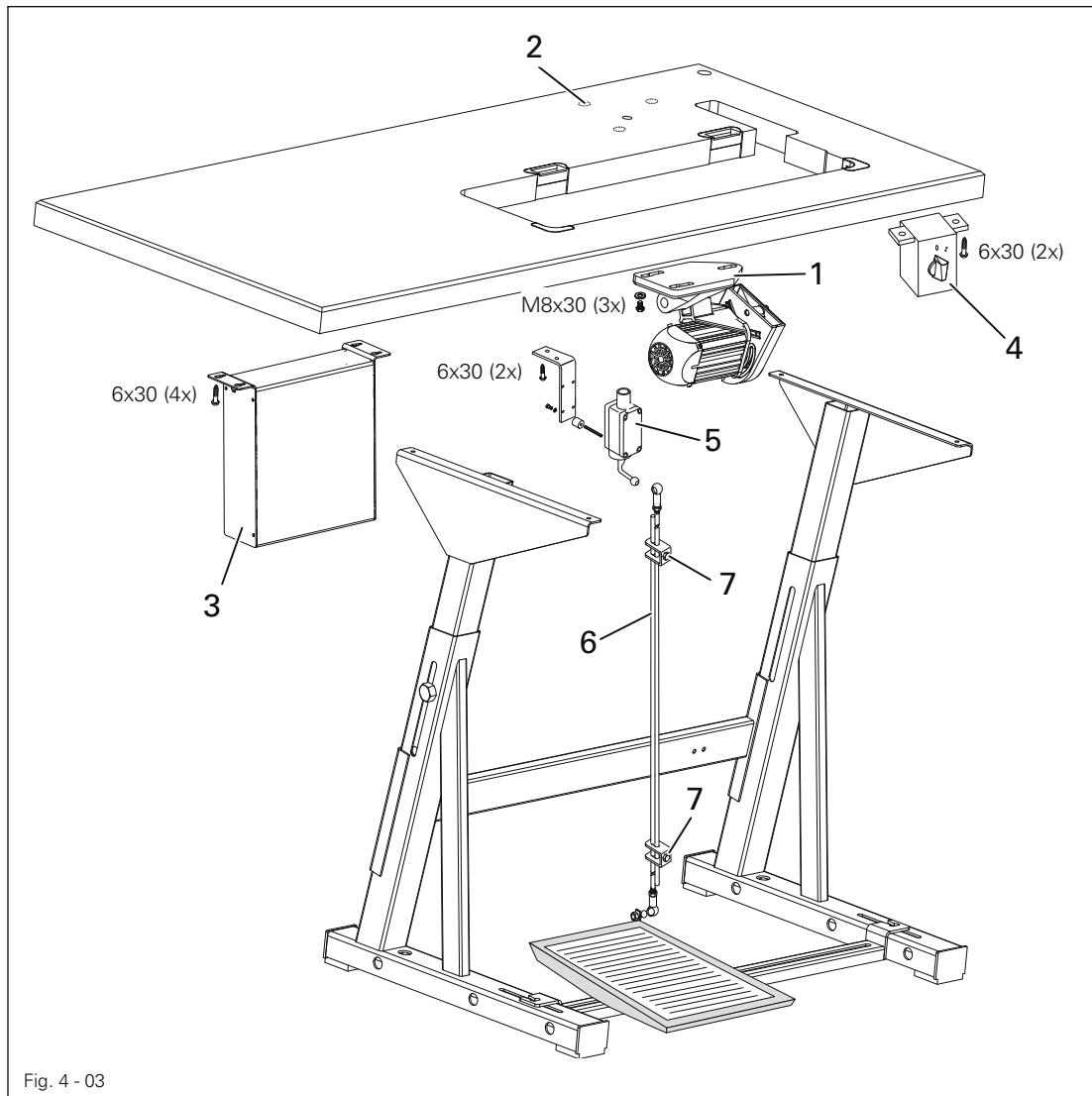
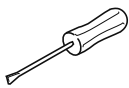

Fig. 4 - 03



- Fasten the motor mounting 1 with motor to the screwed inserts 2 of the table top with three hexagon bolts M8 x 30.
- Fit the control box 3 to the table top with four screws 6x30.
- Attach the mains switch 4 to the table top with two screws 6x30.
- Screw the mains cable of the control box 3 to the table top with a mains lead cleat.
- Assemble the speed control unit 4 and attach it to the table top with two screws 6x30.
- Mount the pedal on the stand's cross-bar, aligning the middle of the pedal with the centre of the needle.
- Fit connection rod 5 to speed control unit 4 and to the pedal.
- The slant of the pedal can be adjusted after loosening screw 6 (slant angle approx. 10°).

5 LED-Lamp (optional)

5.01 Assembling the LED lamp

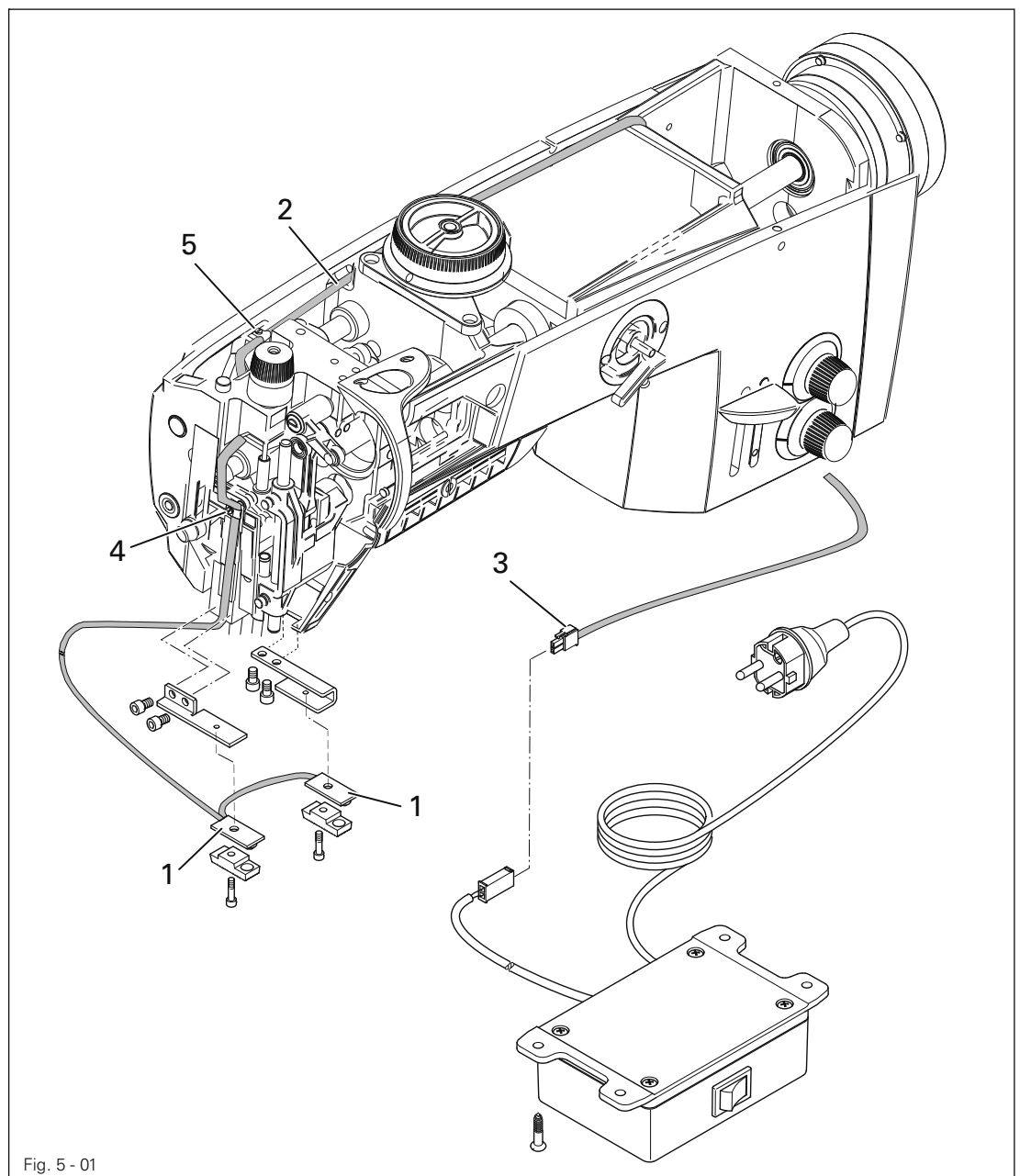
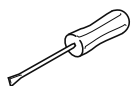
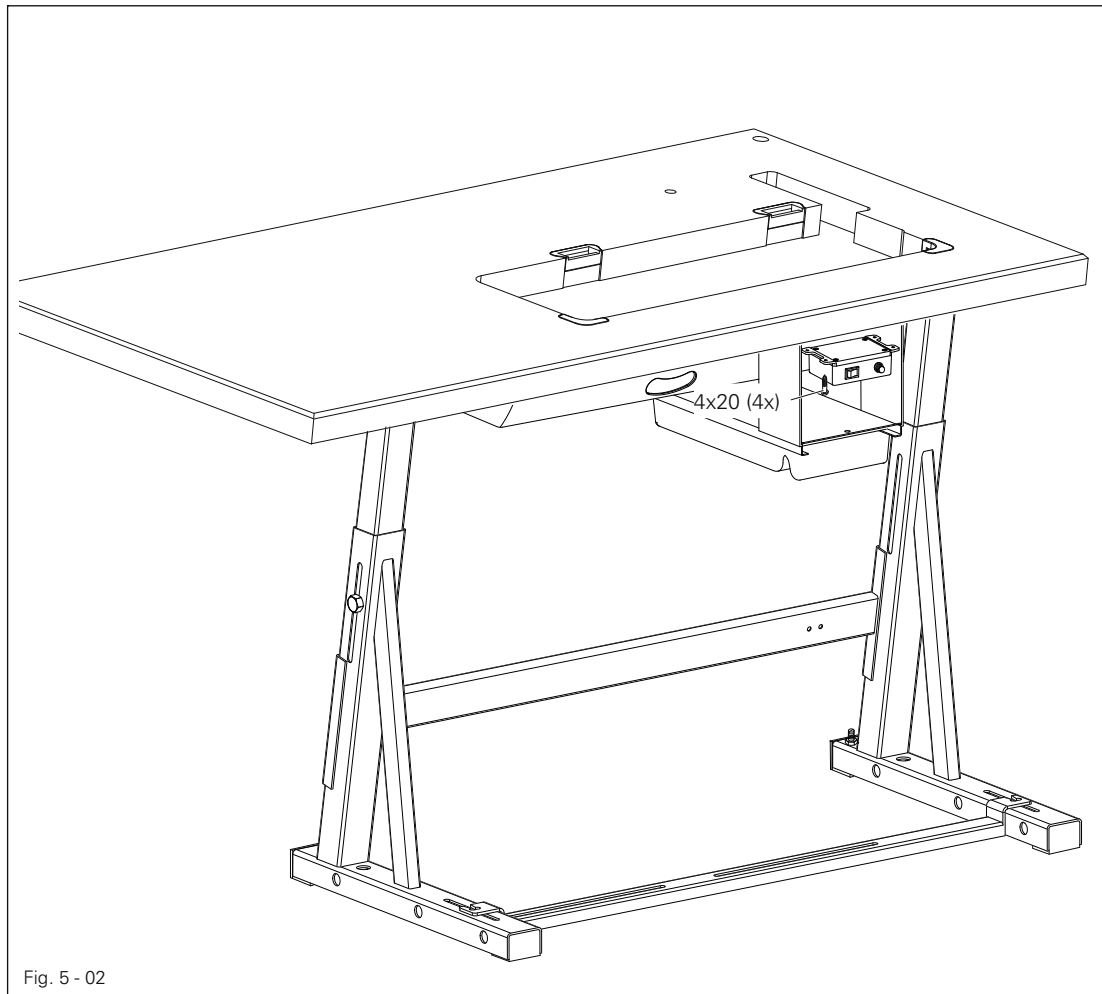

Fig. 5 - 01



- Unscrew the head and arm cover.
- Remove the complete voltage mounting plate.
- Assemble the LED lamps 1 as shown in Fig. 5-01.
- Install cable 2 in the recess of the machine arm and lead plug 3 down through the machine.
- Secure cable 2 with clamps 4 and 5 and the corresponding available screw.
- Reattach the voltage mounting plate and head and arm cover.

5.02 Fitting the transformer to the LED lamp



- Attach transformer 1 to the table top with four screws 4 x 20.
- Screw the power line with clamps and main leads cleat to the table top.
- Connect the cable to the LED lamp with a connector.

6 Installation

6.01 Setting the sewing machine into the stand

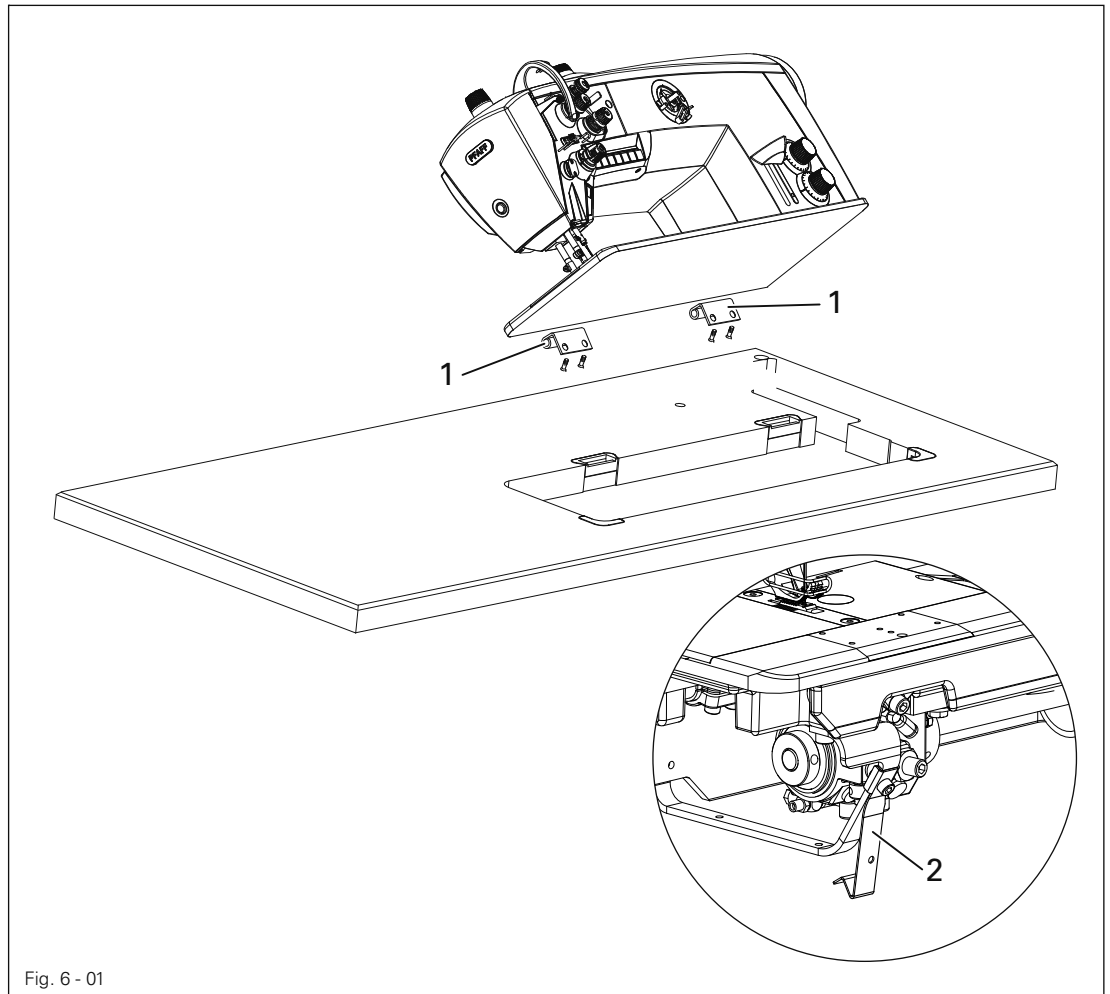
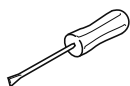
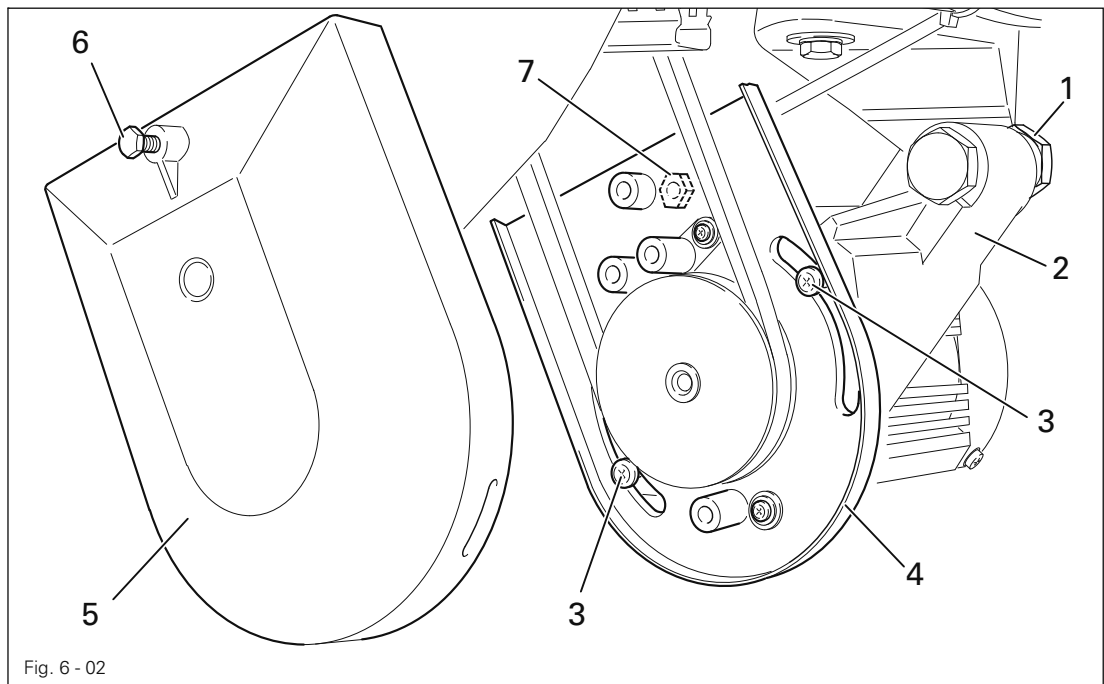

Fig. 6 - 01



- Attach each of the hinges 1 to the sewing head with two screws M6 x 16.
- On the PFAFF 2545 attach tilt lock 2 with a M5 x 6 screw
(on the PFAFF 2231 + 2235 the tilt lock is already attached)
- Set the sewing machine into the table top.

6.02 Fitting the V-belt and assembling the bottom belt guard



- Fit the V-belt to the balance wheel and the motor pulley.
- Loosen nut 1 and apply tension to the V-belt by turning motor mounting 2.
- Tighten nut 1.
- Loosen screws 3 and adjust belt guard bracket 4 so that the driver pulley and V-belt are running freely.
- Tighten screws 3 and fasten belt guard 5 with screw 6 (nut 7).

6.03 Assembling the thread guide and take-up lever guard

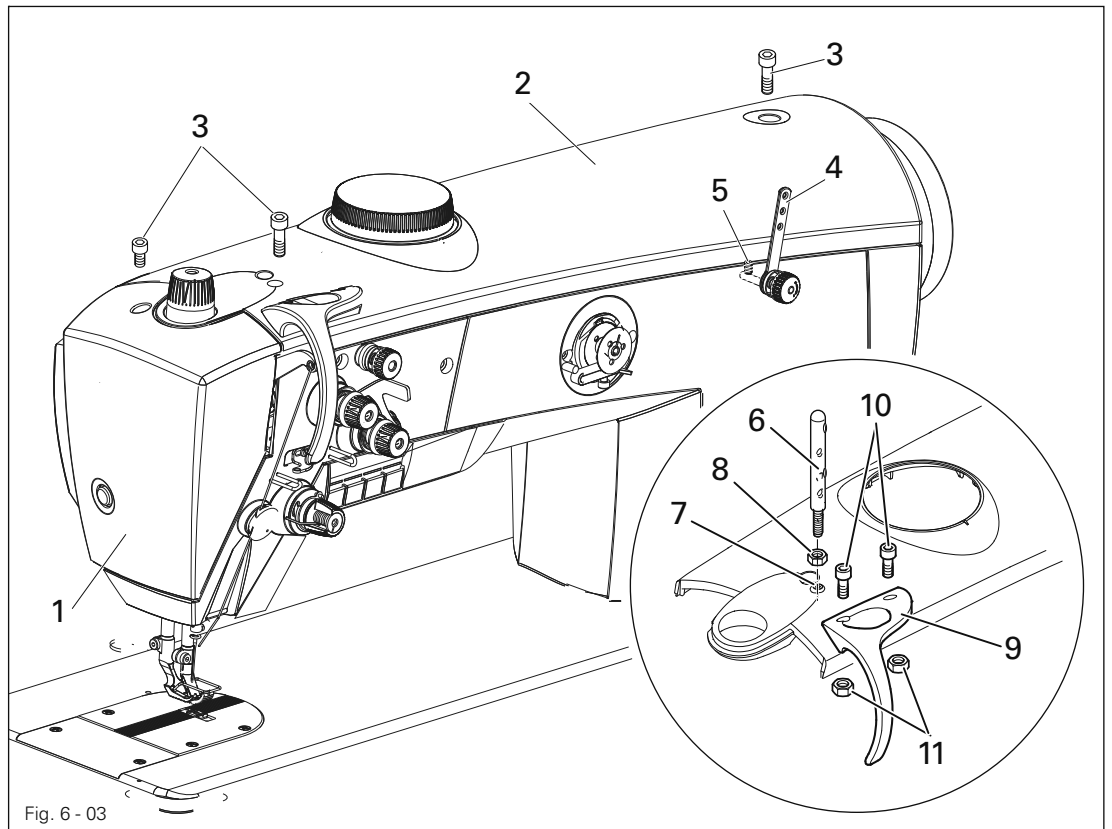

Fig. 6 - 03

- Remove face plate 1 and arm cover 2 (screws 3).
- Adjust thread guide 4 (screw 5) as shown in Fig. 6 - 03.
- Screw thread guide 6 into threaded hole 7 and fit counter nut 8 from below.
- Fasten take-up lever guard 9 to the arm cover 2 with screws 10 (M4x10) and nuts 11 as shown in Fig. 6 - 03.



Leave face plate and arm cover unscrewed for the next assembly steps.

6.04 Assembling the top V-belt guard and sewing head support

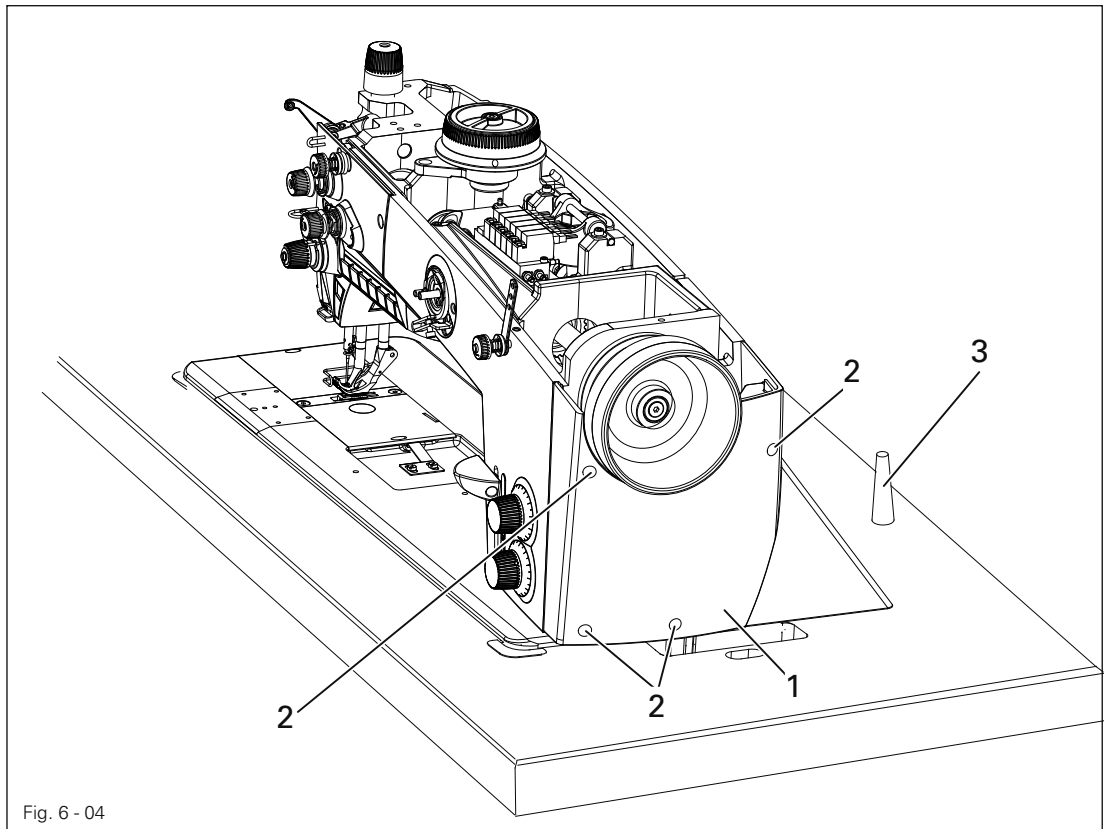

- Attach guard belt 1 with screws 2.
- Insert sewing head support 3 into the hole in the table top.



Do not operate the machine with support 3! Danger from top-heavy sewing head! Machine cannot fall over when tilted backwards!

6.05 Mounting the control panel

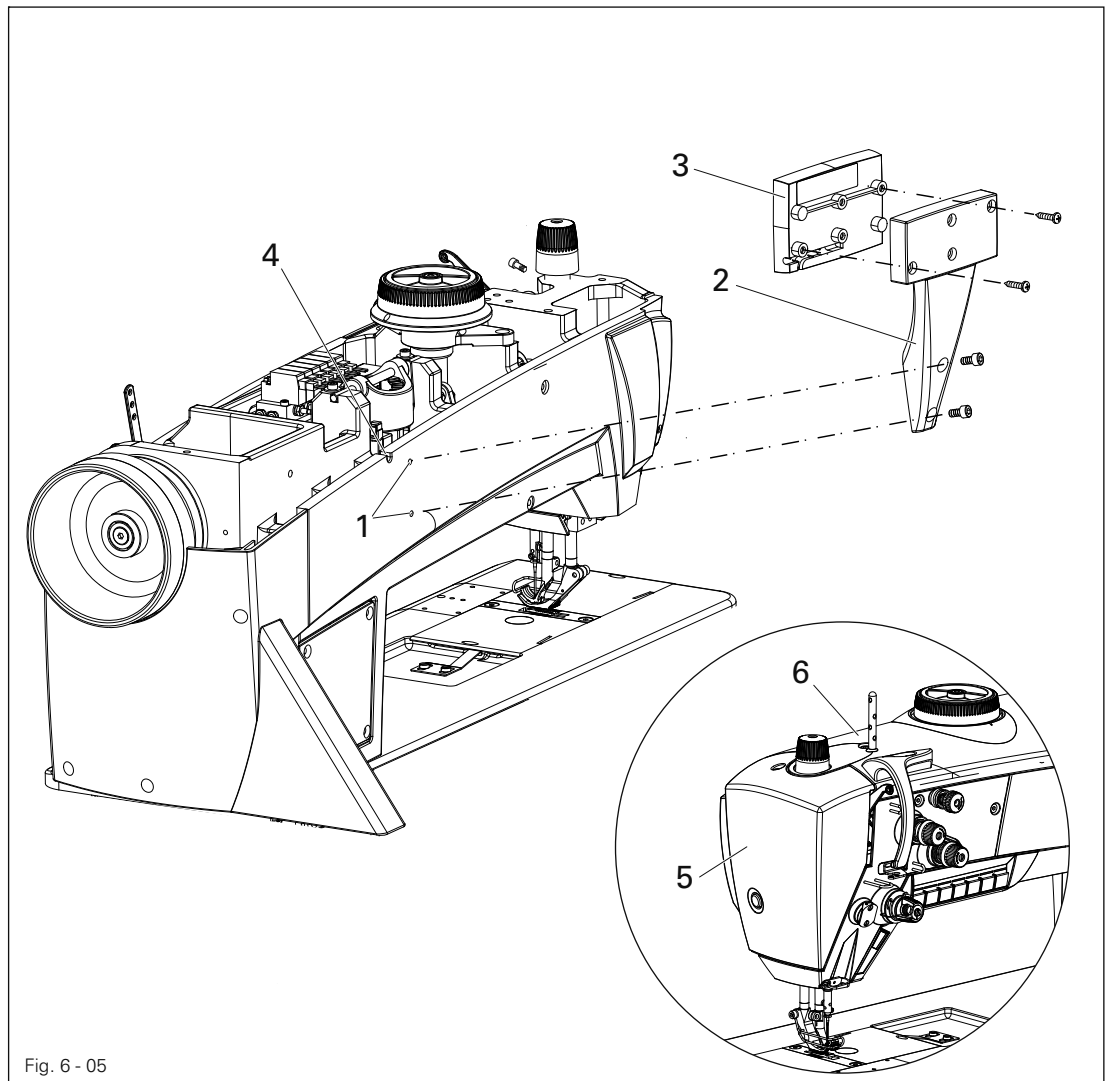

Fig. 6 - 05

- Fasten the control panel bracket 2 to the threaded holes 1 with two screws M5 x 12.
- Attach control panel 3 to bracket 2 with two screws 5 x 10.
- Lead the control panel cable through hole 4 in the case.
- Connect the control panel plug with the connector provided for the control panel in the arm of the machine.
- Reattach face plate 5 and arm cover 6.

6.06 Connecting the plug-in connections and earth cables

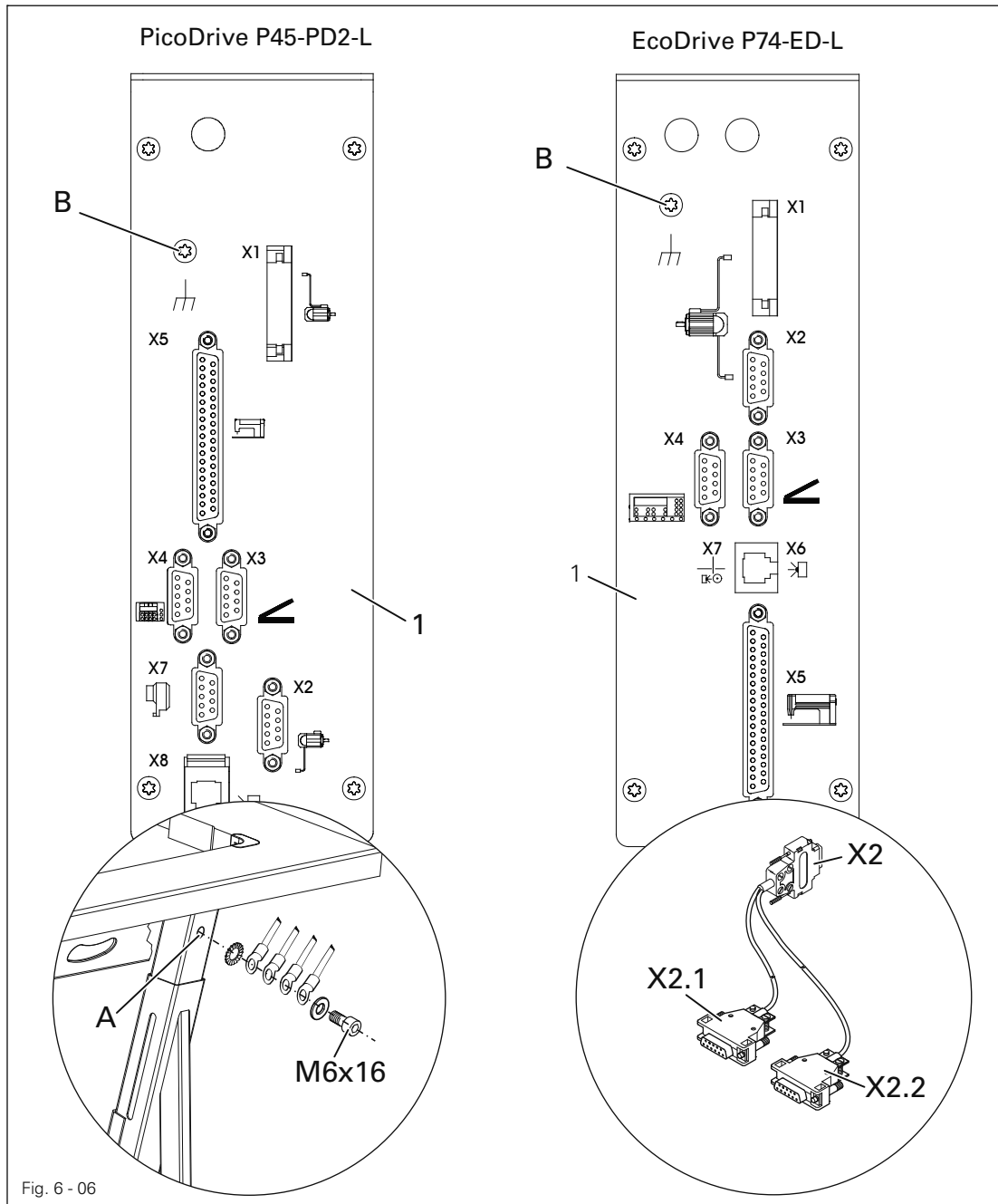

Fig. 6 - 06

- Connect all plugs as labelled on the control box 1
- In the case of control unit EcoDrive P74 ED-L the adapter cable X2 is to be connected to socket X2. Plug X2.1 is to be connected to the motor and plug X2.2. to the synchronizer.
- Connect the earth cable from the superstructure (480 mm) to the earthing connection A.
- Join earthing connection A and earthing connection B with the earth cable (700 or 100 mm).
- Connect the earthing connection on the motor base with earthing connection A with the earth cable (700 mm)
- On control P74 ED-L connect main switch and earthing connection A with the earth cable (500 mm).
- Fasten the earth cable from plug X1 to earth point B.

6.07 Block diagram

6.07.01 PFAFF 2231 and 2235 with PicoDrive P45 PD2-L

Synchronizer PD 6

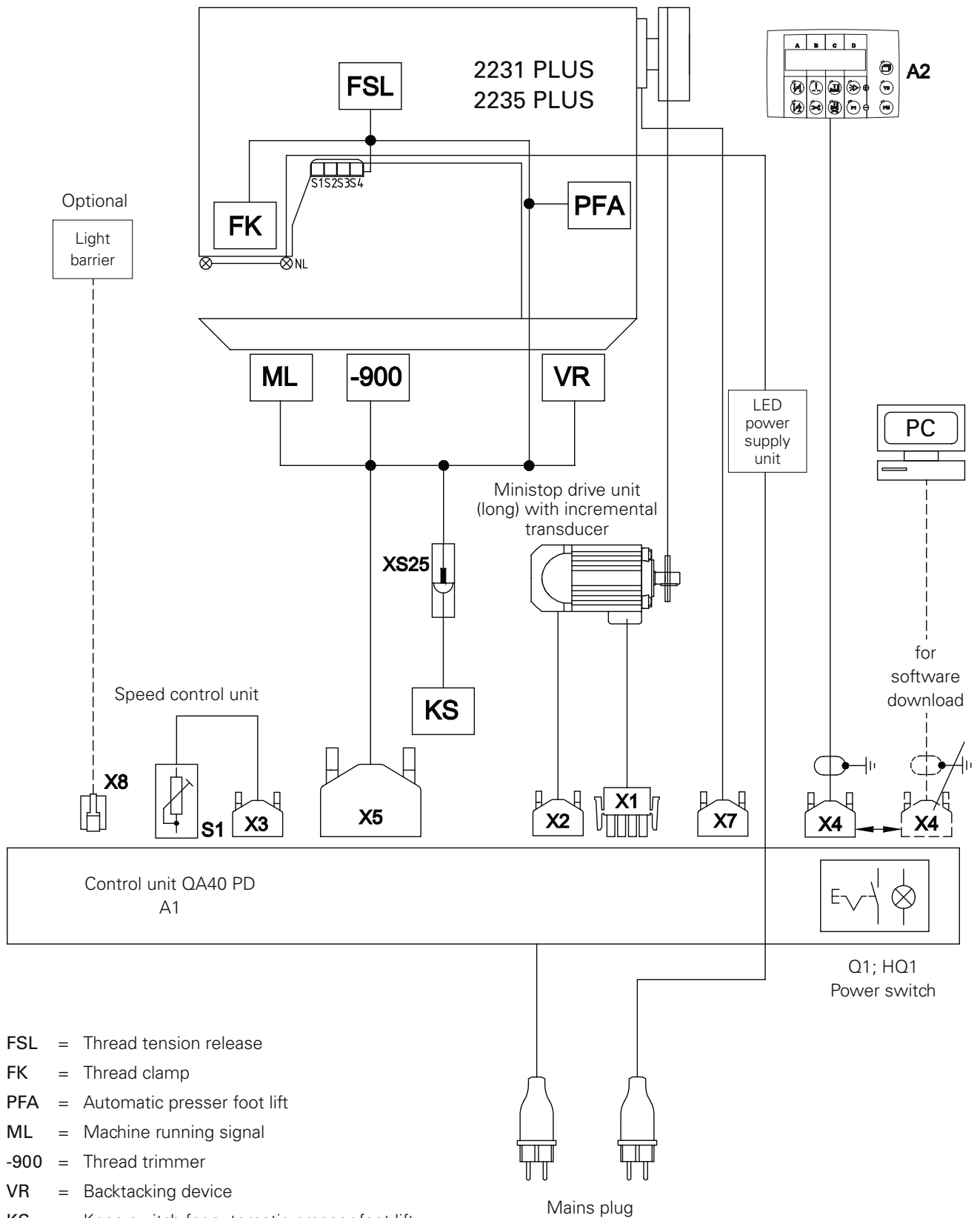

Installation

6.07.02 PFAFF 2235 and 2545/46 with EcoDrive P74 ED-L

Synchronizer PD 6

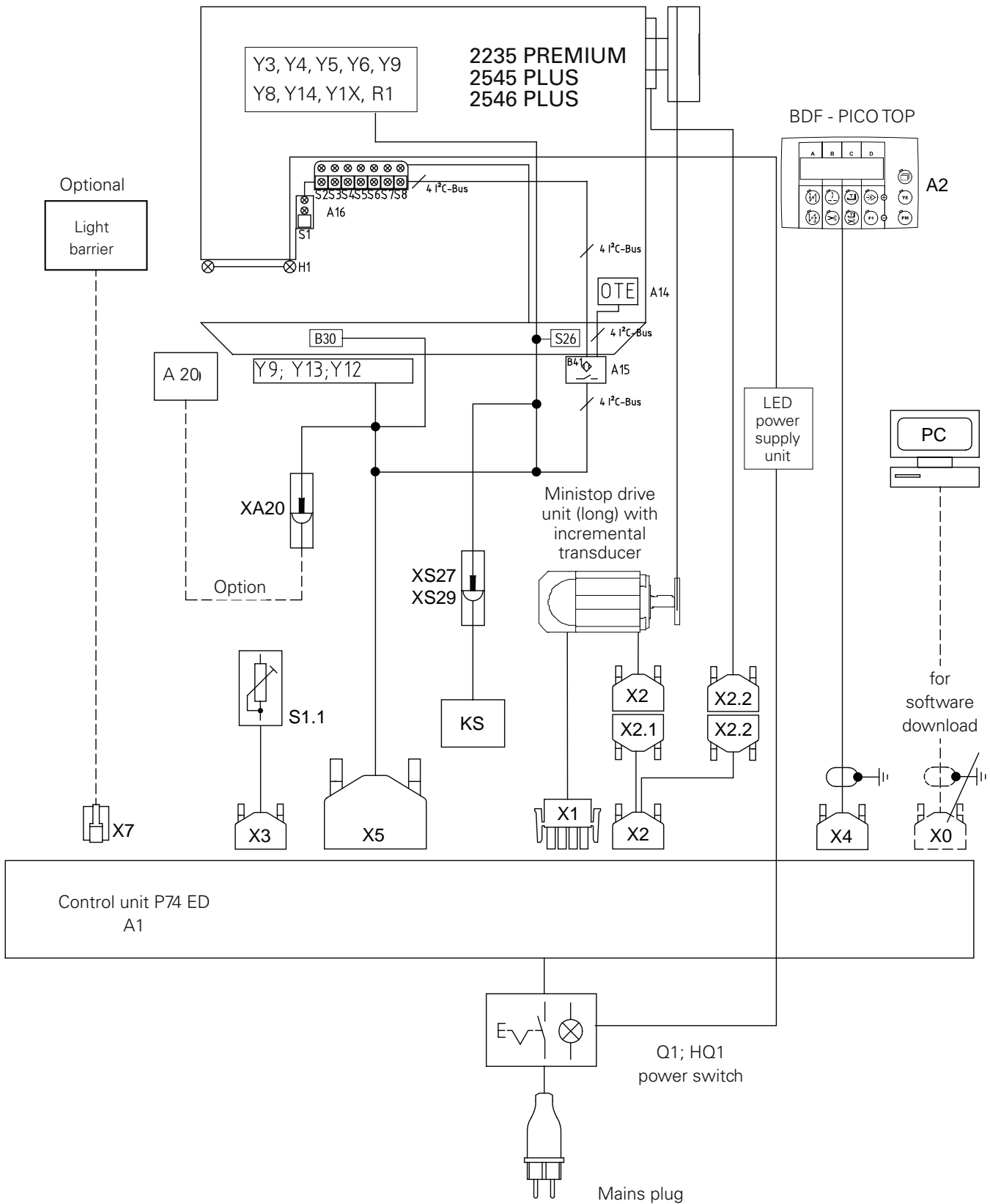

6.07.03 PFAFF 2545/46 BASIC with PicoDrive P45 PD2-L

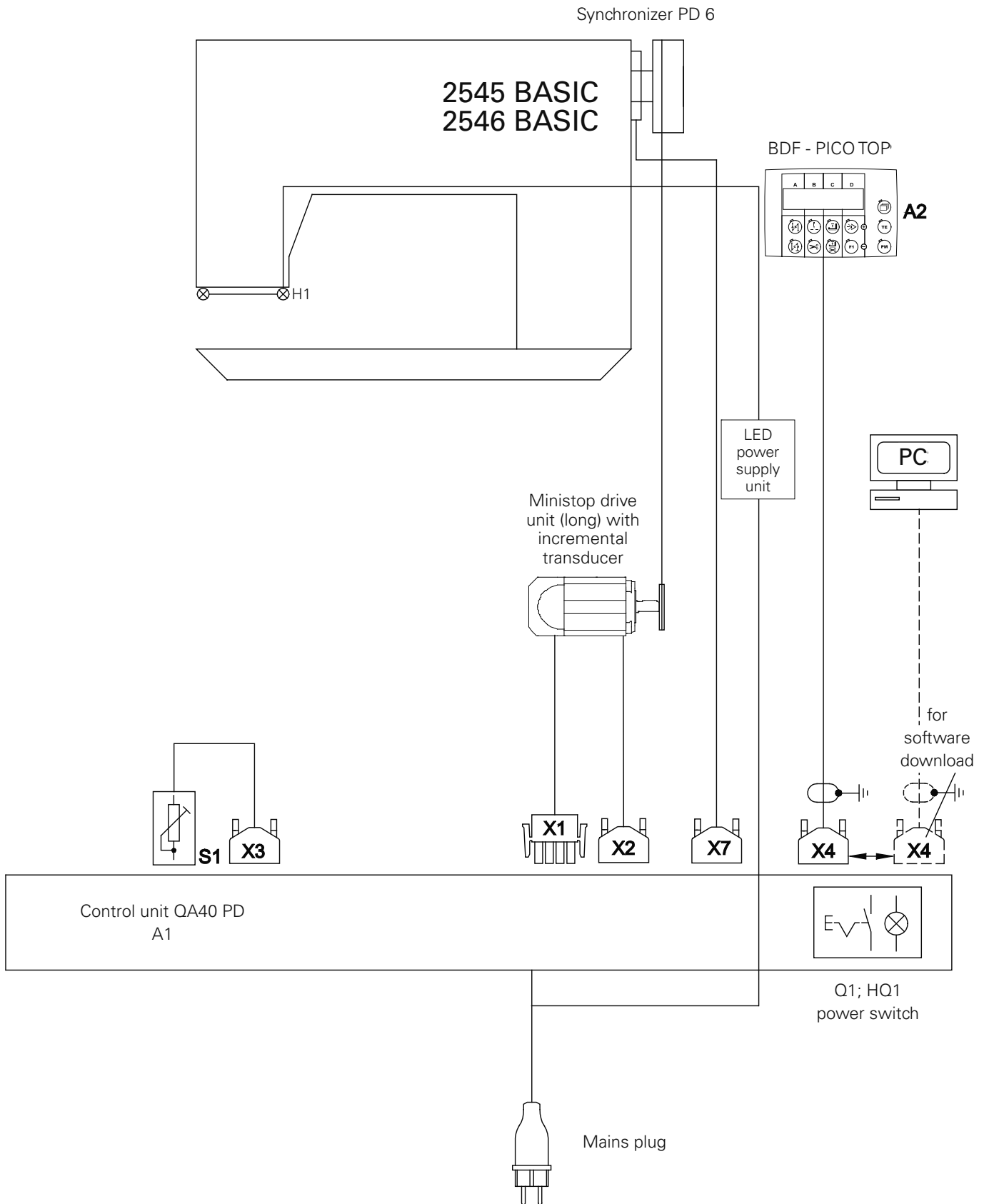

6.08 Mounting / connecting the maintenance unit

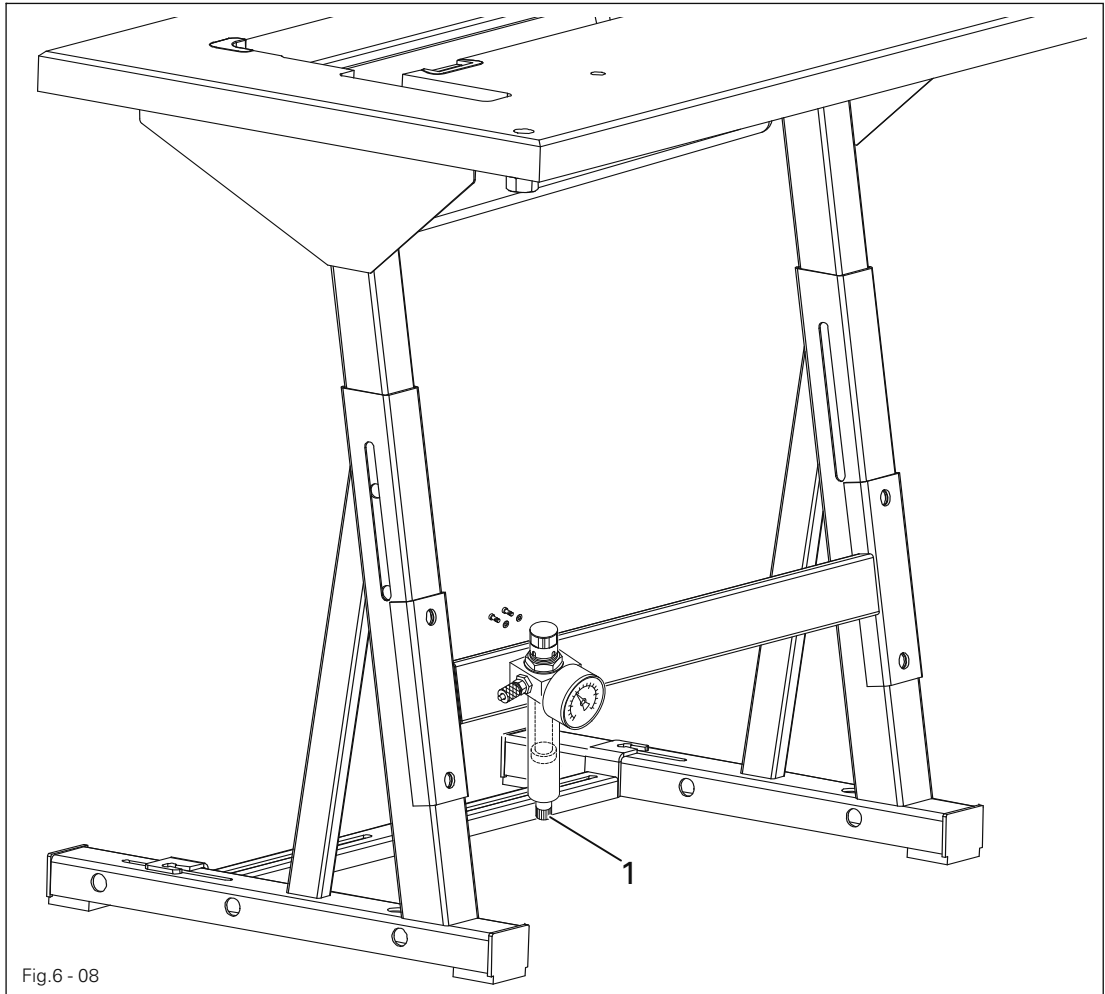

- Attach maintenance unit 1 to the stand with two screws M6 x 25.
- Connect the maintenance unit to the machine's pneumatic tube.



To ensure the perfect functioning of all pneumatic devices, there must be a supply system pressure of between **8** and **10** bar.
The operating pressure is **6** bar (also see Chapter 9 Care and Maintenance of the Service Manual).

7 Commissioning



Before commissioning the machine, it must be thoroughly cleaned and then oiled., see chapter 9 **Care and maintenance** in the instruction manual.

- Check the machine, particularly its electrical wiring and pneumatic tube connections, for any damage.
- Have skilled personnel check if the machine can be operated with the available mains voltage.



Do not operate the machine if there is any discrepancy.



The machine may only be connected to an earthed socket!

- In the case of machines with PicoDrive and **P45 PD2-L** control unit, have specialists check the basic position of the machine drive before commissioning the machine (see Chapter 7.02 **Basic position of the machine drive**).

7.01 Switching the machine on/off

- Switch the machine on (see Chapter 7.01, **On/off switch** in the instruction manual).

7.02 Basic position of the machine drive

(only on machines with PicoDrive)

- Switch on the machine.
- When the machine is commissioned, "**Pulley**" appears on the display.
- Call up the parameter input by pressing the scroll key.
- Press the **TE key** to switch the function keys to input function (LED in the **TE key** is illuminated).
- Press the corresponding **+/- keys** to select parameter "**798**" and select the service level **C**, see chapter Selecting the User Level in the separate instruction manual for the control panel.
- Select parameter "**800**" by pressing the corresponding **+/- keys**.
- Check whether the value is set at "**1**" (balance wheel turns towards operator) and alter if necessary.
- Press the **scroll key** until "**Pulley**" appears on the display.
- If the pedal is operated, the control unit carries out a teach-in operation.
- The machine runs at low speed until the teach-in operation is completed.
- This operation cannot be interrupted.
- After the teach-in operation, the "**Pulley**" disappears from the screen - display returns to standard.
- Select parameter "**700**" by pressing the **+/- keys**.
- Sew one stitch by operating the pedal.
- Turn the balance wheel in the direction of rotation until the needle point, **descending from above**, is flush with the top edge of the needle plate.
- Conclude the adjustment of the sewing motor by pressing the **scroll key**.



On machines with EcoDrive P74 ED-L it is not necessary to check the basic position of the machine drive unit.

These machines are equipped with an automatic sewing head recognition function.



Europäische Union
Wachstum durch Innovation – EFRE



PFAFF Industriesysteme und Maschinen AG

Hans-Geiger-Str. 12 - IG Nord
D-67661 Kaiserslautern

Phone: +49-6301 3205 - 0
Fax: +49-6301 3205 1386
E-mail: info@pfaff-industrial.com

Hotlines:

Technical service: +49-175/2243-101
Application consultancy: +49-175/2243-102
Spare-parts hotline: +49-175/2243-103

Printed in Germany