

***POWER*Line**

**2545**

**2546**

ADJUSTMENT MANUAL

This Adjustment Manual is valid for machines  
from the following serial numbers onwards:

# 7 206 577 →

The reprinting, copying or translation of PFAFF Service Manuals, whether in whole or in part, is only permitted with our previous authorization and with written reference to the source.

**PFAFF Industriesysteme  
und Maschinen AG**

Hans-Geiger-Str. 12 - IG Nord

D-67661 Kaiserslautern

[www.promelectroavtomat.ru](http://www.promelectroavtomat.ru)

Contenu .....	Page
<b>1</b>	<b>Ajustage..... 4</b>
1.01	Remarques liées au réglage..... 4
1.02	Outils, calibres et autres moyens auxiliaires ..... 4
1.03	Abréviations ..... 4
1.04	Explication des symboles ..... 4
1.05	Ajustage de la machine de base ..... 5
1.05.01	Position initiale du volant (aide au réglage) ..... 5
1.05.02	Contrepoids ..... 6
1.05.03	Position initiale du transport inférieur, supérieur et du transport de l'aiguille ..... 7
1.05.04	Mouvement de décalage du transport inférieur, supérieur et du transport de l'aiguille ..... 8
1.05.05	Mouvement de levage du transport inférieur..... 9
1.05.06	Hauteur du transport inférieur ..... 11
1.05.07	Différence de déplacement ..... 12
1.05.08	Prérégler la hauteur d'aiguille..... 13
1.05.09	Remontée d'aiguille, écartement crochet / aiguille, hauteur d'aiguille et pare-aiguille..... 14
1.05.10	Course du transport supérieur ..... 16
1.05.11	Mouvement de levage du transport inférieur..... 17
1.05.12	Réglage du potentiomètre pour la réduction de la vitesse ..... 18
1.05.13	Trajet du dégageur de capsule ..... 19
1.05.14	Réglage du point de coupure raccourci ..... 20
1.05.15	Bobinoir..... 21
1.05.16	Ressort de relevage du fil et régulateur du fil ..... 22
1.05.17	Pression du pied-de-biche ..... 23
1.05.18	Lubrification ..... 24
1.05.19	Limitation de la longueur de points..... 25
1.05.20	Réduction de la vitesse..... 26
1.05.21	Réenclenchement de l'accouplement à glissement ..... 27
1.06	Réglage du dispositif coupe-fil -900/81 ..... 28
1.06.01	Position de repos du levier à galet / Position radiale de la came de commande ..... 28
1.06.02	Position et hauteur de l'attrape-fil ..... 29
1.06.03	Pression du couteau ..... 30
1.06.04	Ressort de friction du fil inférieur..... 31
1.06.05	Essai de coupe manuel..... 32
<b>2</b>	<b>Schéma fonctionel PFAFF 2545/46 PLUS avec PF 321 ..... 34</b>

## 1 Adjustment



Please observe all notes from Chapter 1 **Safety** of the instruction manual!  
In particular care must be taken to see that all protective devices are refitted properly after adjustment, see Chapter 1.06 **Danger warnings** of the instruction manual!



If not otherwise stated, the machine must be disconnected from the electrical power supply. Danger of injury due to unintentional starting of the machine!

### 1.01 Notes on adjustment

All following adjustments are based on a fully assembled machine and may only be carried out by expert staff trained for this purpose.

Machine covers, which have to be removed and replaced to carry out checks and adjustments, are not mentioned in the text.

The order of the following chapters corresponds to the most logical work sequence for machines which have to be completely adjusted. If only specific individual work steps are carried out, both the preceding and following chapters must be observed.

Screws, nuts indicated in brackets ( ) are fastenings for machine parts, which must be loosened before adjustment and tightened again afterwards.

### 1.02 Tools, gauges and other accessories for adjusting

- Screwdrivers with blade width from 2 to 10 mm
- Spanners (wrenches) with jaw width from 7 to 14 mm
- 1 set Allen keys from 1.5 to 6 mm
- 1 gauge for the top feed stroke 5.0 mm (Part No. 61-111 633-60)
- 1 feed dog adjustment gauge, Part No. 61-111 689-04
- Metal rule (part No. 08-880 218-00)
- Sewing thread and test materials

### 1.03 Abbreviations

t.d.c. = top dead centre

b.d.c. = bottom dead centre

### 1.04 Explanation of the symbols

In this adjustment manual, symbols emphasize operations to be carried out or important information. The symbols used have the following meaning:



Note, information

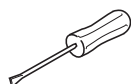

Service, repair, adjustment, maintenance  
(work to be carried out by qualified staff only)

## 1.05 Adjusting the basic machine

### 1.05.01 Basic position of the balance wheel (adjustment aid)

#### Requirement

When the needle bar is positioned at t.d.c., the marking "0" on the scale should be level with the top edge of the belt guard (see arrow).

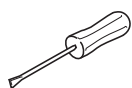
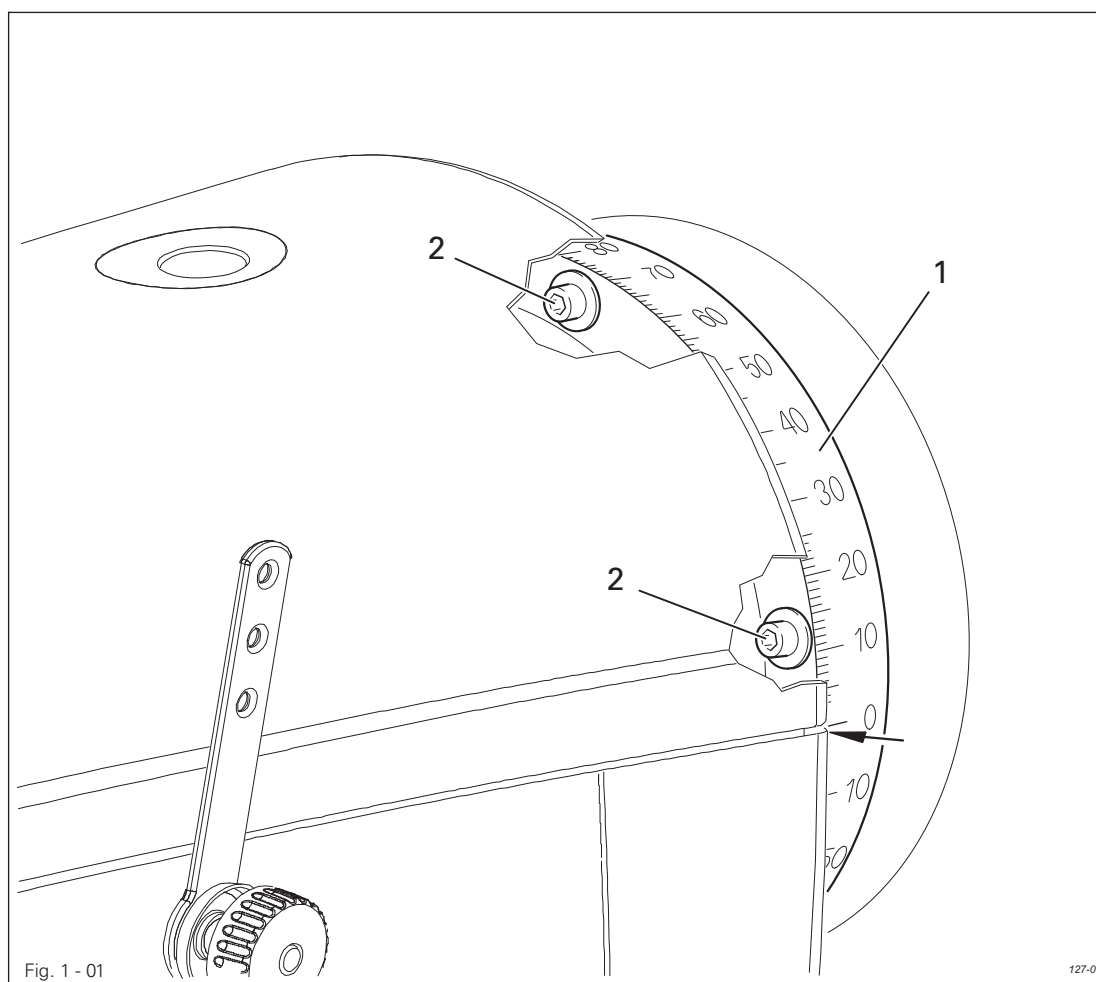

Adjust the scale dial 1 (four screws 2) in accordance with the requirement.

# Adjustment

## 1.05.02 Balance weight

### Requirement

When the needle bar is positioned at b.d.c. (balance wheel position  $180^\circ$ ) the largest eccentricity of the balance weight 1 should be at the top.

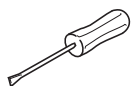
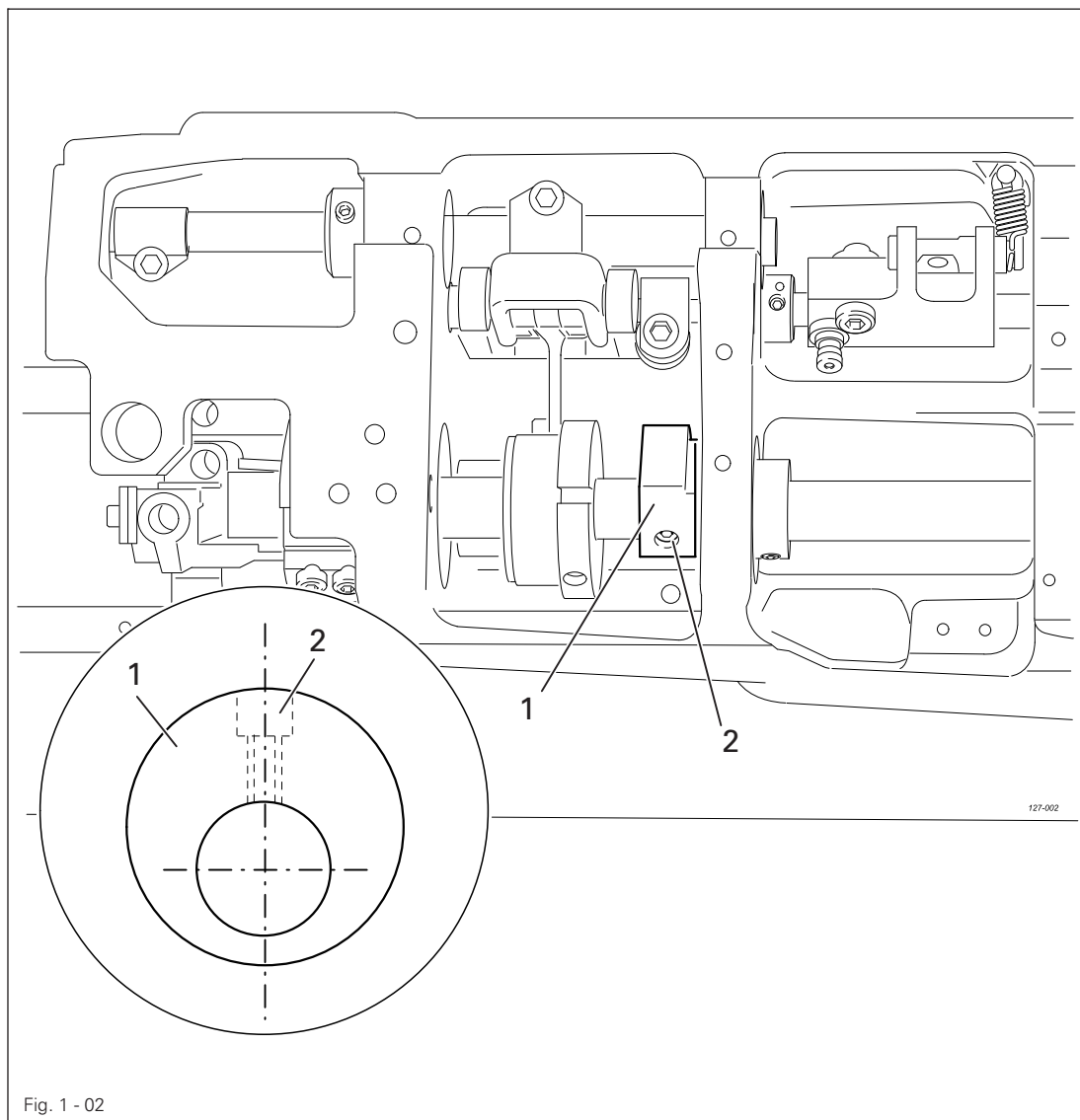

- Adjust balance weight 1 (screw 2) in accordance with the requirement.

## 1.05.03 Zero position of the unison feed

**Requirement**

When the stitch length is set at "0", the top and bottom feed dogs and the needle bar should not make any feeding motion when the balance wheel is turned.

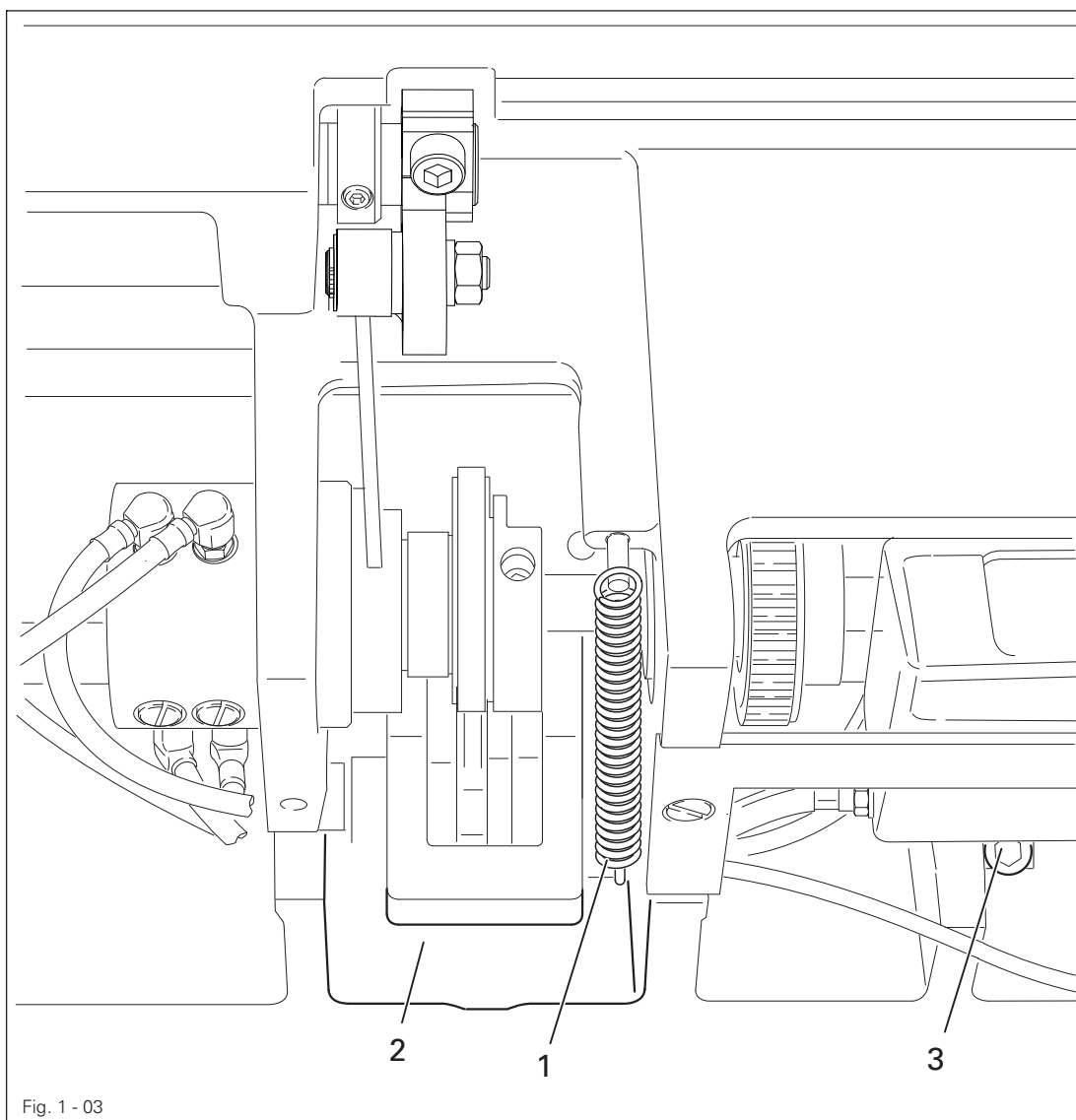
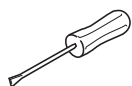

Fig. 1 - 03



- Remove spring 1.
- Adjust crank 2 (screw 3) in accordance with the requirement.
- Replace the spring 1.

## 1.05.04 Feeding motion of the unison feed

### Requirement

When the needle bar is positioned at b.d.c. (balance wheel position  $180^\circ$ ), and the maximum stitch length is set, the top and bottom feed dogs and the needle bar should not make any feeding motion when the reverse-feed lever is pressed.

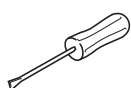
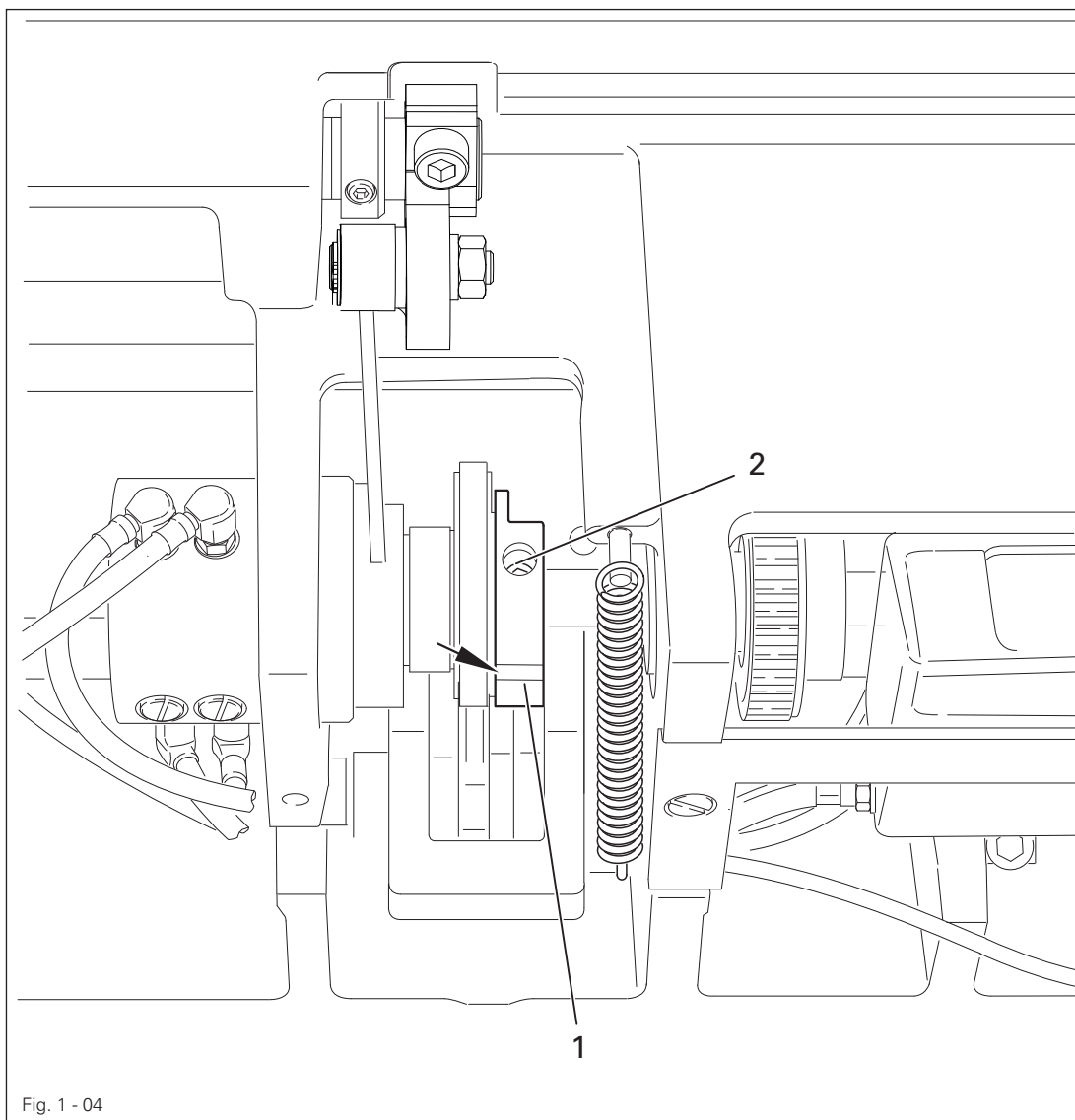

- Adjust eccentric **1** (screws **2**) in accordance with the **requirement**. Make sure that the cut-out (see arrow) is visible.



## 1.05.05 Lifting motion of the bottom feed dog

**Requirement**

When the balance wheel is positioned at  $180^\circ$ , the feed dog should be at t.d.c.

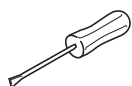
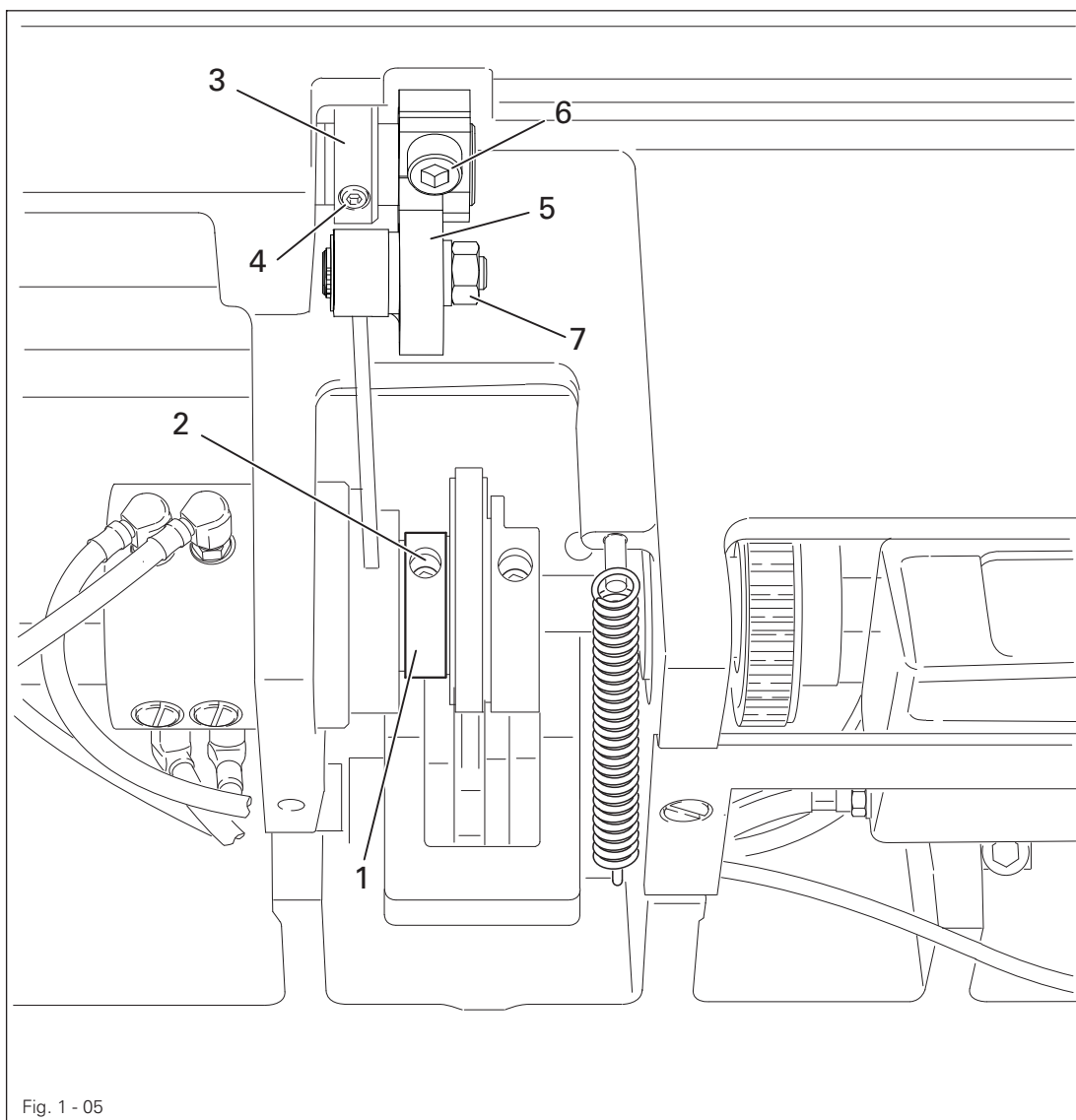

- Adjust eccentric 1 (screws 2) in accordance with the **requirement**.



Use the kit with the Order No. 91-501 399-90 to deactivate the transporter lifting movement.

**Install assembly and adjust**

- Remove collar 3 (screws 4) and crank 5 (screw 6, nut 7).
- Mount the preassembled parts of the kit as shown in figures 1 - 05a.
- Adjust bottom transporter height and stroke movement where required.

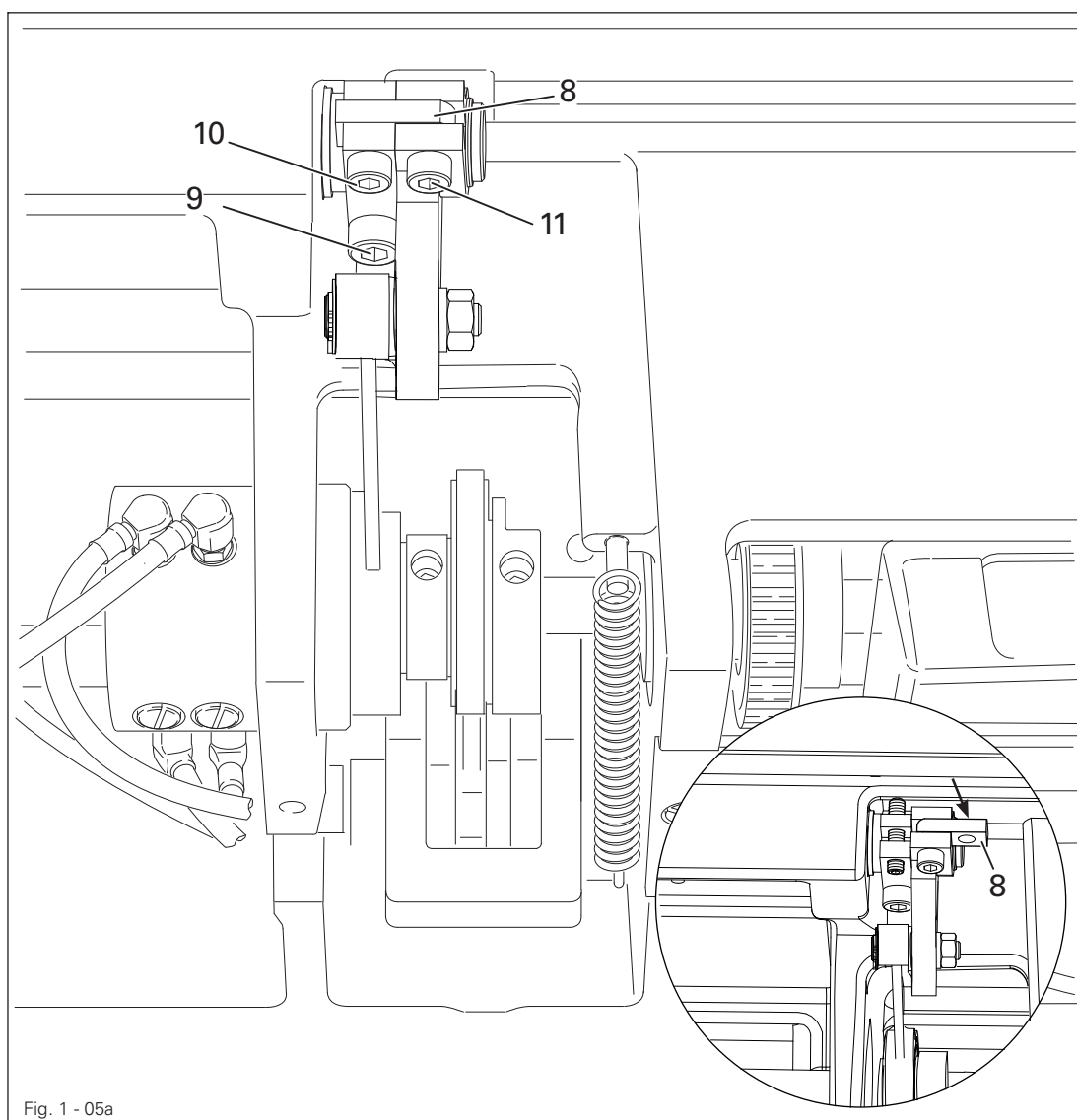
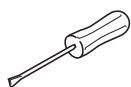

Fig. 1 - 05a



### Activate lifting movement

- Lifting movement is activated if connection part **8** is swiveled in as shown in figures 1 - 05a, and screws **9** (M6 x 16) and **10** (M5 x 16) have been attached.

### Deactivate lifting movement

- Remove screws **9** and **10** and swivel connection part **8** (screw **11**) towards the right.
- Replace screw **9** with a screw M6 x 25.
- Replace screw **10** with a threaded pin M5 x 25 and tighten to stop.



Adjust transporter height with deactivated stroke movement so that the upper edge of the transporter is at the height of the upper edge of the needle plate. Adjust the transporter height once again with the stroke movement activated, as described in chapter 1.05.06.

## 1.05.06 Height of the bottom feed dog

**Requirement**

1. When the needle bar is positioned at b.d.c. (balance wheel position  $180^\circ$ ), the bottom feed dog should be positioned **0.5 mm** horizontally above the top edge of the needle plate, when crank **5** is in the centre of the slot.
2. In the direction of sewing, the bottom feed dog should be positioned in the centre of the needle plate slot.

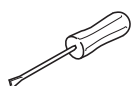
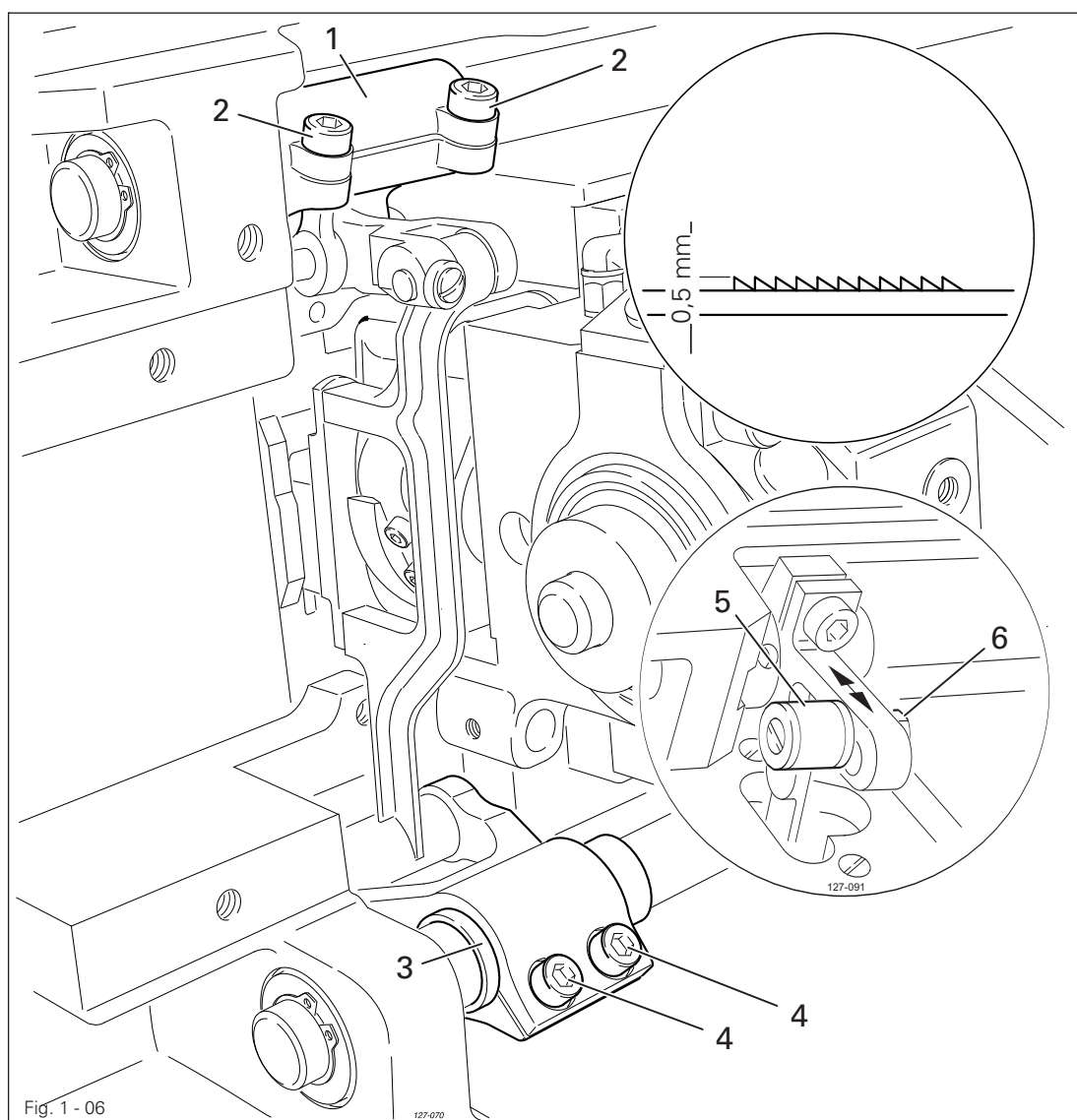

- Turn lifting crank **1** (screws **2**) and eccentric sleeve **3** (screws **4**) according to **Requirement 1**, and set feed dog in centre of needle-plate slot as shown in **Requirement 2**.



The height of the bottom feed dog can also be increased or reduced as required by moving crank **5** (nut **6**) up or down.

## Adjustment

### 1.05.07 Feeding stroke difference

#### Requirement

With the maximum stitch length set, when the balance wheel is turned the feeding strokes of the needle and the bottom feed dog should be the same.

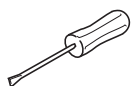
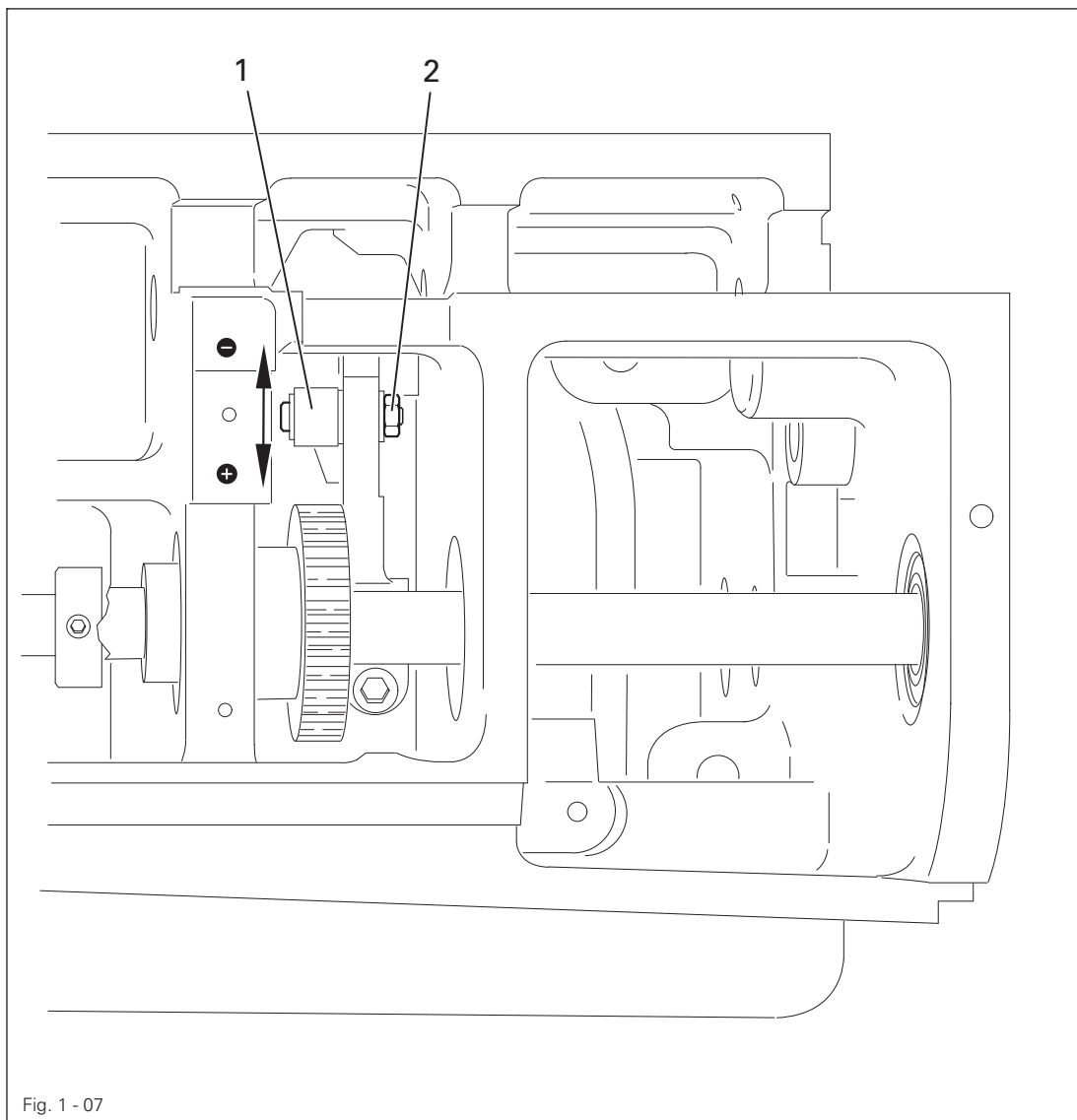

- With connecting rod 1 (nut 2) increase ("+") or reduce (-) the needle feed stroke in accordance with the **requirement**.

## 1.05.08 Preliminary adjustment of the needle height

### Requirement

When the needle bar is positioned at t.d.c. (balance wheel position 0°), the clearance between the needle point and the needle plate should be 22 mm.

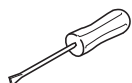
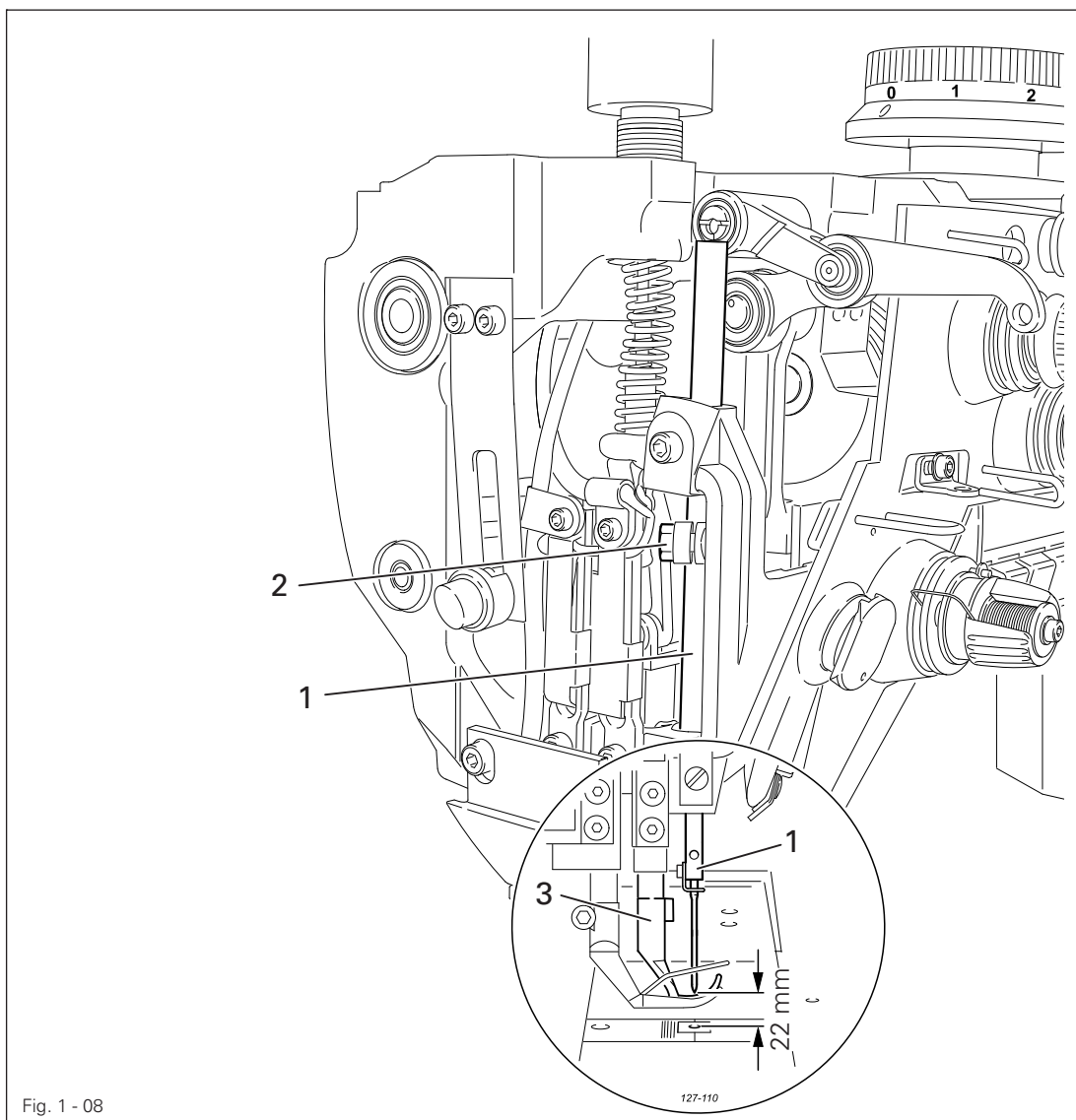

- Without turning it, re-position needle bar 1 (screw 2) in accordance with the requirement.



Make sure that needle bar 1 and foot 3 do not collide.

## 1.05.09 Needle rise, hook clearance, needle height and needle guard

### Requirement

With the stitch length set at "4.5" and in the needle rise position (see table)

1. The hook point **6** should be positioned at "needle centre" with a hook-to-needle clearance of **0.05 – 0.10 mm**.
2. The top of the needle eye should be positioned **0.8 mm** below hook point **6**.
3. and needle guard **7** must touch the needle just lightly.



### Needle rise position

Model C: Balance wheel position **204° / 2.0 mm**

Model D: Balance wheel position **206° / 2.4 mm**

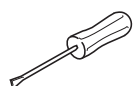
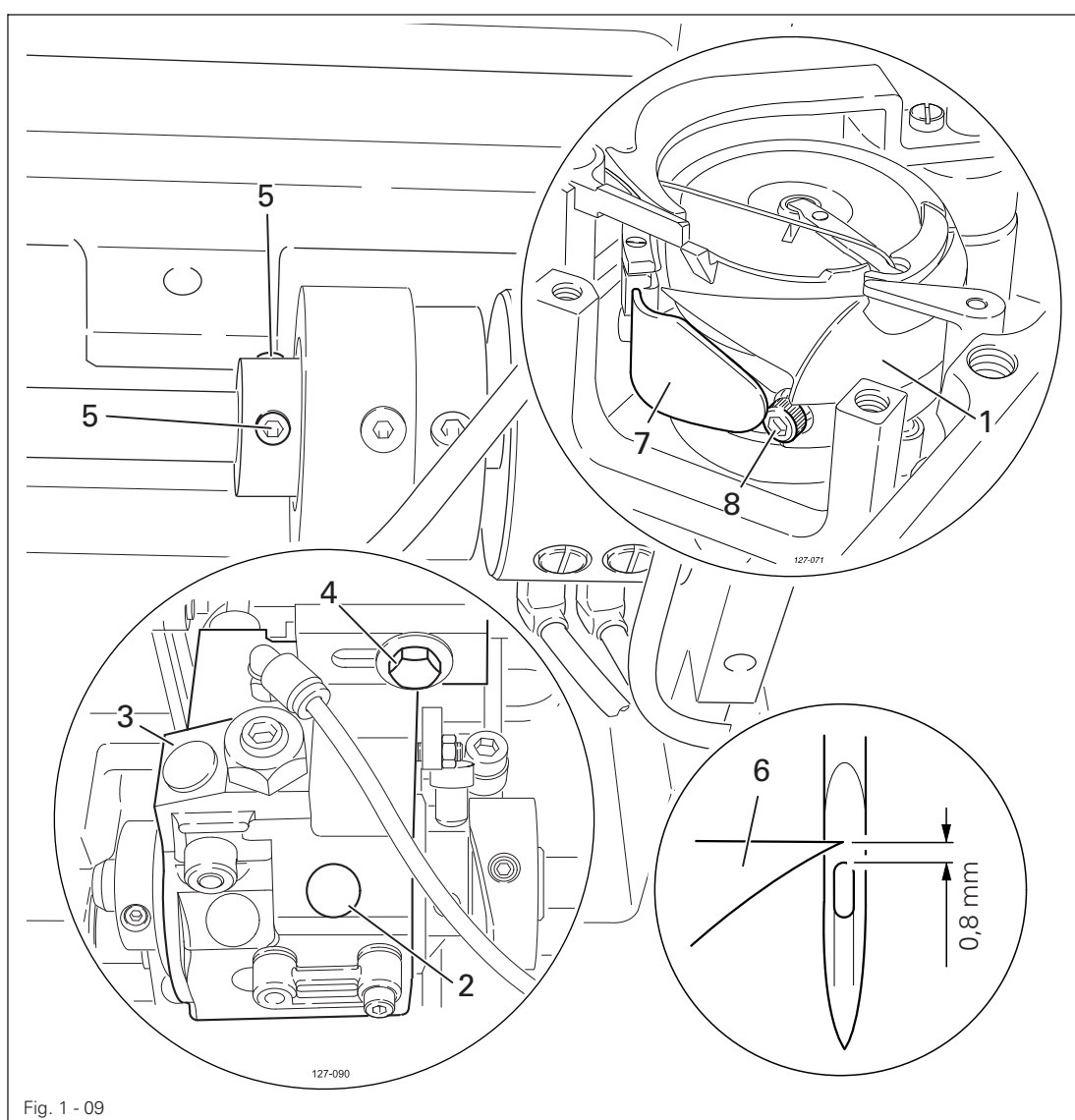

- Loosen both screws of the gear drive of hook **1** (under cover **2**).
- Adjust hook **1** and hook bearing **3** (screws **4** and **5**) in accordance with **requirement 1**.
- Without turning it, re-position the needle bar in accordance with the **requirement 2**, also see Chapter 1.05.08 Preliminary adjustment of the needle bar.

- Adjust needle guard 7 (screw 8) in accordance with requirement 3.



If the needle size is changed, a quick adjustment of hook bearing 3 is possible, after loosening screws 4 and 5.

## 1.05.10 Top feed stroke

### Requirement

With adjustment wheel 1 set at "5", the top feed dog 7 and presser foot 4 should each rise by 5.0 mm.

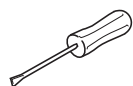
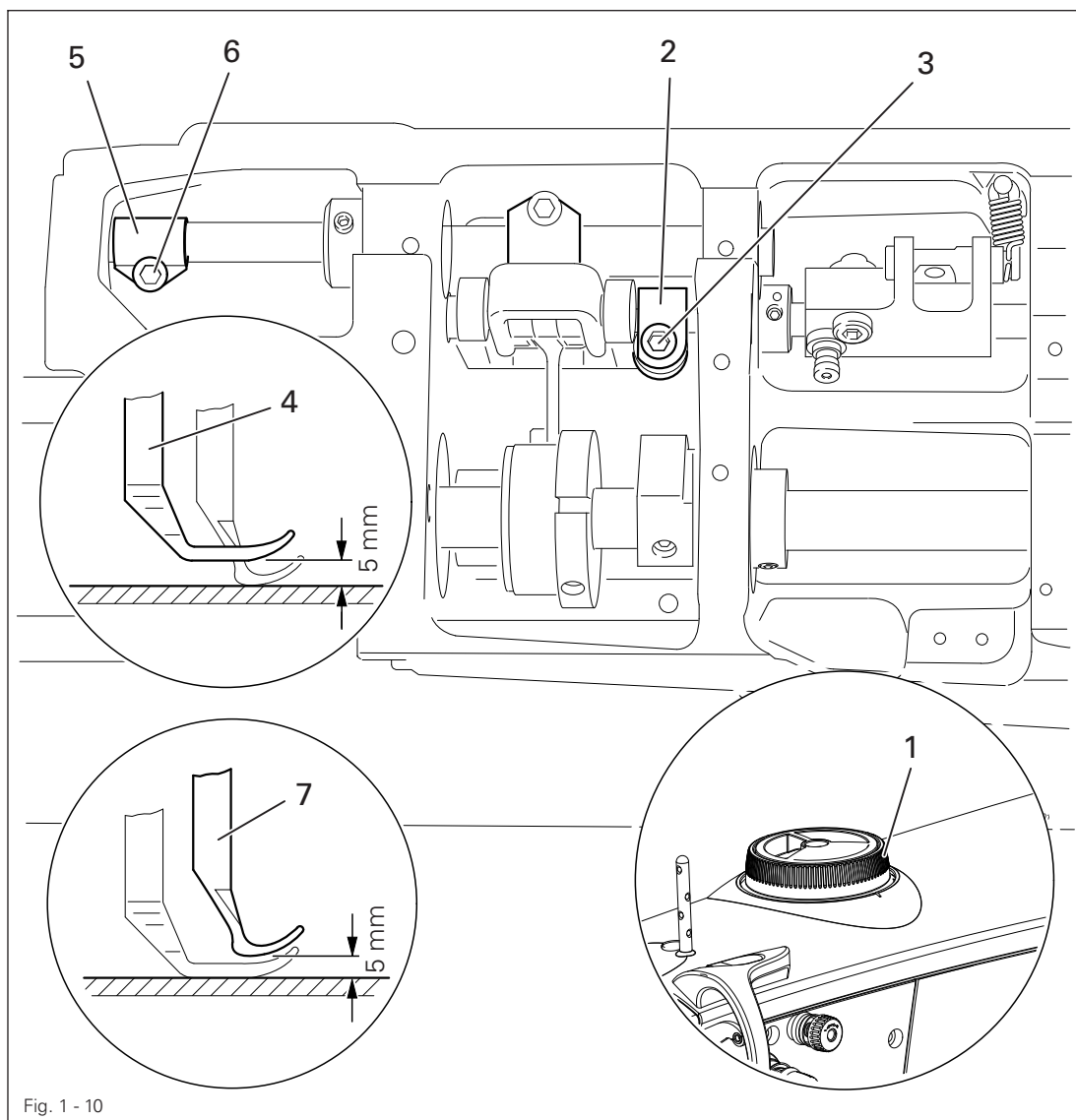

- Remove the bottom feed dog and set adjustment wheel 1 at "5".
- Loosen the screws of the needle plate, place the metal gauge over the opening of the needle plate slot so that both sewing feet can be lowered onto the metal gauge.
- For the preliminary adjustment, adjust crank 2 (screw 3) so that there is a clearance of 5 mm between presser foot 4 and the needle plate.
- Adjust crank 5 (screw 6) so that top feed dog 7 and presser foot 4 have the same stroke.
- Check the adjustment in accordance with the **requirement**, and correct if necessary.



## 1.05.11 Top-feed lifting motion

**Requirement**

The top feed dog should just have reached the needle plate when the presser foot lift is set at **5 mm** and the needle descending from above is **2 mm** above the needle plate.

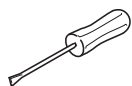
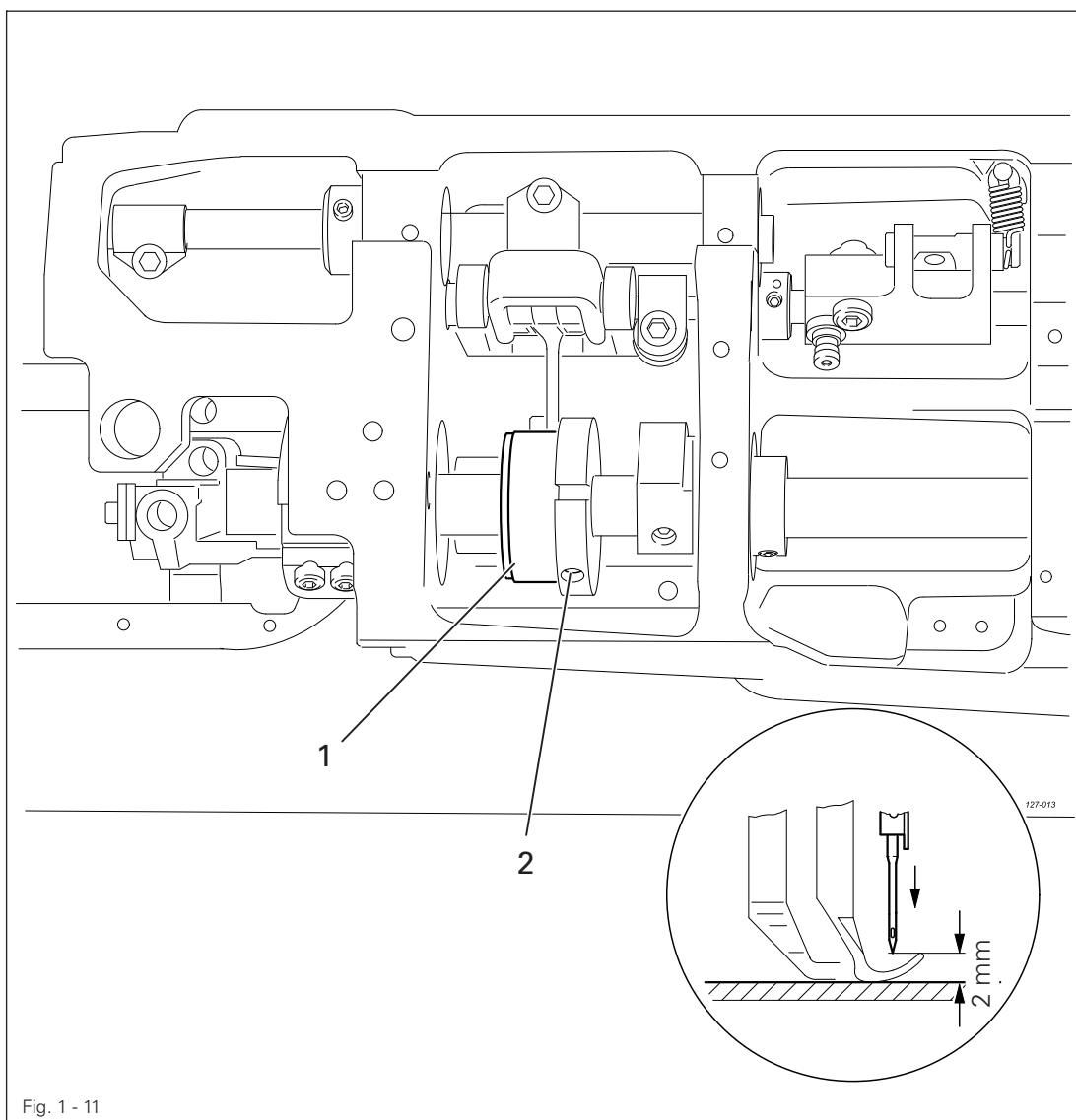

- Turn eccentric 1 (screw 2) in accordance with the requirement.

### 1.05.12 Adjusting the potentiometer for speed reduction

- Press "P" on the control panel, while simultaneously switching the machine on.
- Enter the code **3112** via the numbered keys and confirm by pressing "E".
- Select parameter **501** via the numbered keys and confirm by pressing "E".
- Set the smallest stroke "0".
- Using the stroke adjustment function, call up the small stroke (LED off), see instruction manual.
- Take over the value displayed under parameter **501** by pressing "+".
- Select parameter **502** via the numbered keys.
- Set the largest stroke "0".
- Using the stroke adjustment function, call up the large stroke (LED on).
- Take over the value displayed under parameter **502** by pressing "+".
- Press "P" twice to quit the input level
- The new values are taken over when sewing is started, and these are maintained even after the machine is switched off.



The speed is adjusted in accordance with Chapter **3.03 Maximum Speed** in the instruction manual.

Under parameter **117** the speed at max. stroke adjustment can be reduced again.

## 1.05.13 Bobbin case opener stroke

**Requirement**

When the balance wheel is turned

1. The beak 4, when it is at the right point of reversal of the bobbin case opener 1, should rise from the needle plate 5 by the thickness of the thread.
2. The bobbin case opener 1 should be at its left point of reversal when the balance wheel is positioned at "10°".

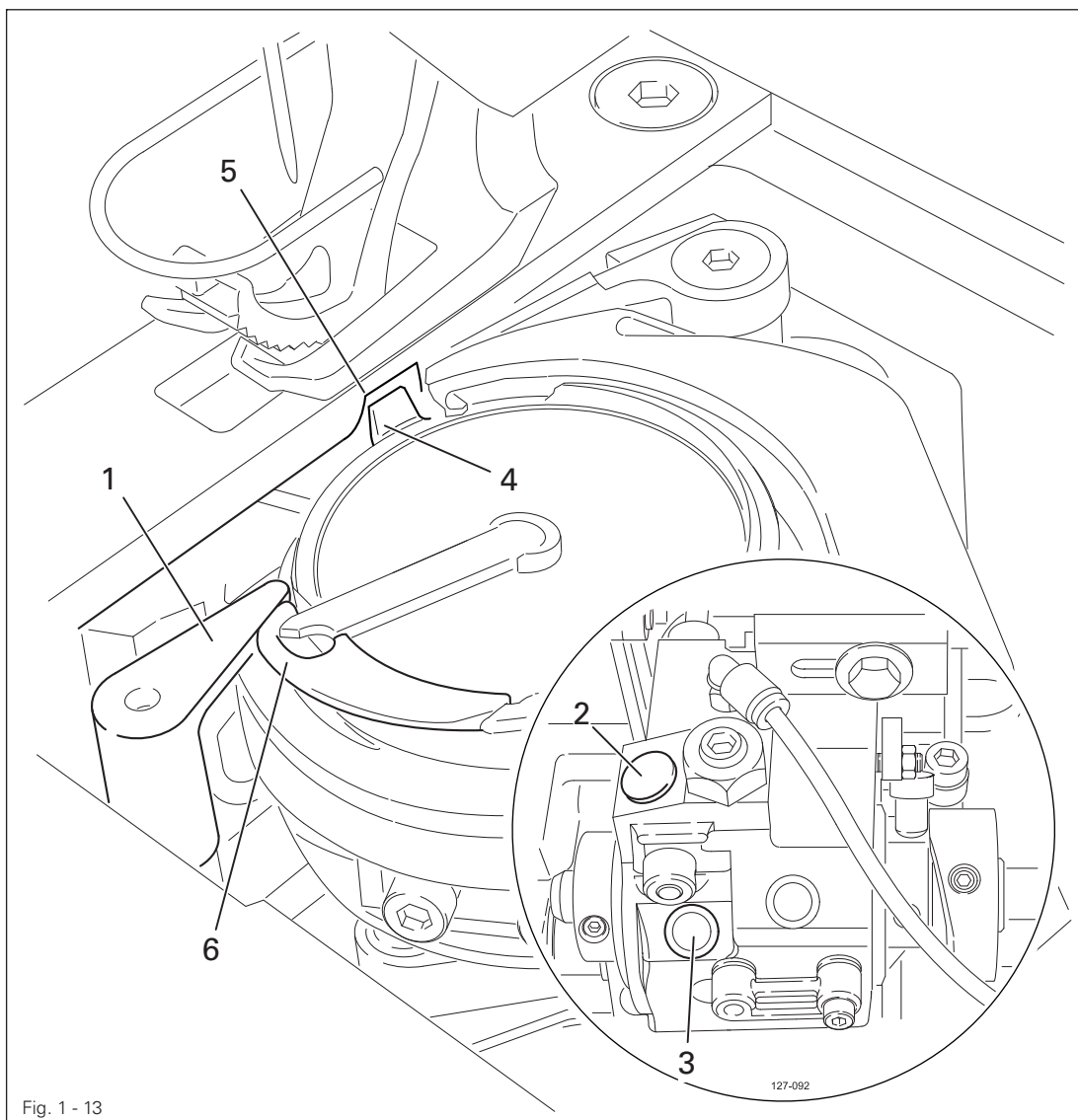
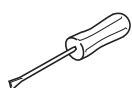

Fig. 1 - 13



- Adjust bobbin case opener 1 (screw under cover 2) in accordance with **requirement 1**.
- Adjust the eccentric (screw under cover 3) in accordance with **requirement 2**.



The thread must be able to pass unhindered between bobbin case opener 1 and bobbin case 6.

## Adjustment

### 1.05.14 Adjusting the shortened trim stitch

#### Requirement

For the trim stitch the machine should carry out a stitch length of **0.5 – 1.0 mm**.

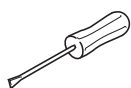
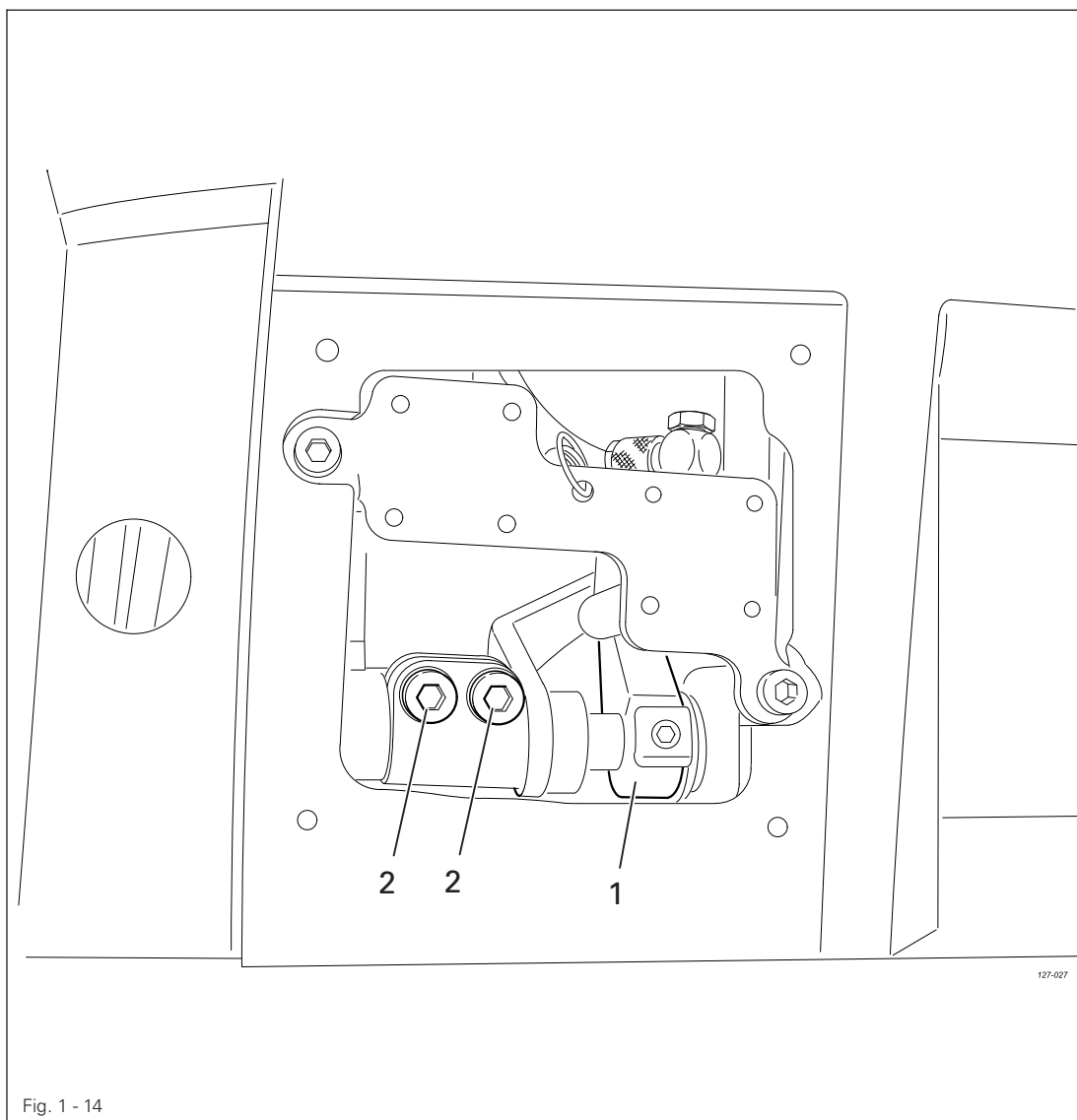

- Adjust lever 1 (screws 2) in accordance with the **requirement**.

## 1.05.15 Bobbin winder

**Requirement**

1. When the bobbin winder is engaged, the winding spindle must be driven reliably.  
When it is disengaged, friction wheel **3** should not be touching drive wheel **1**.
2. When it is switched off, the bobbin winder must click securely into its end position (knife raised).

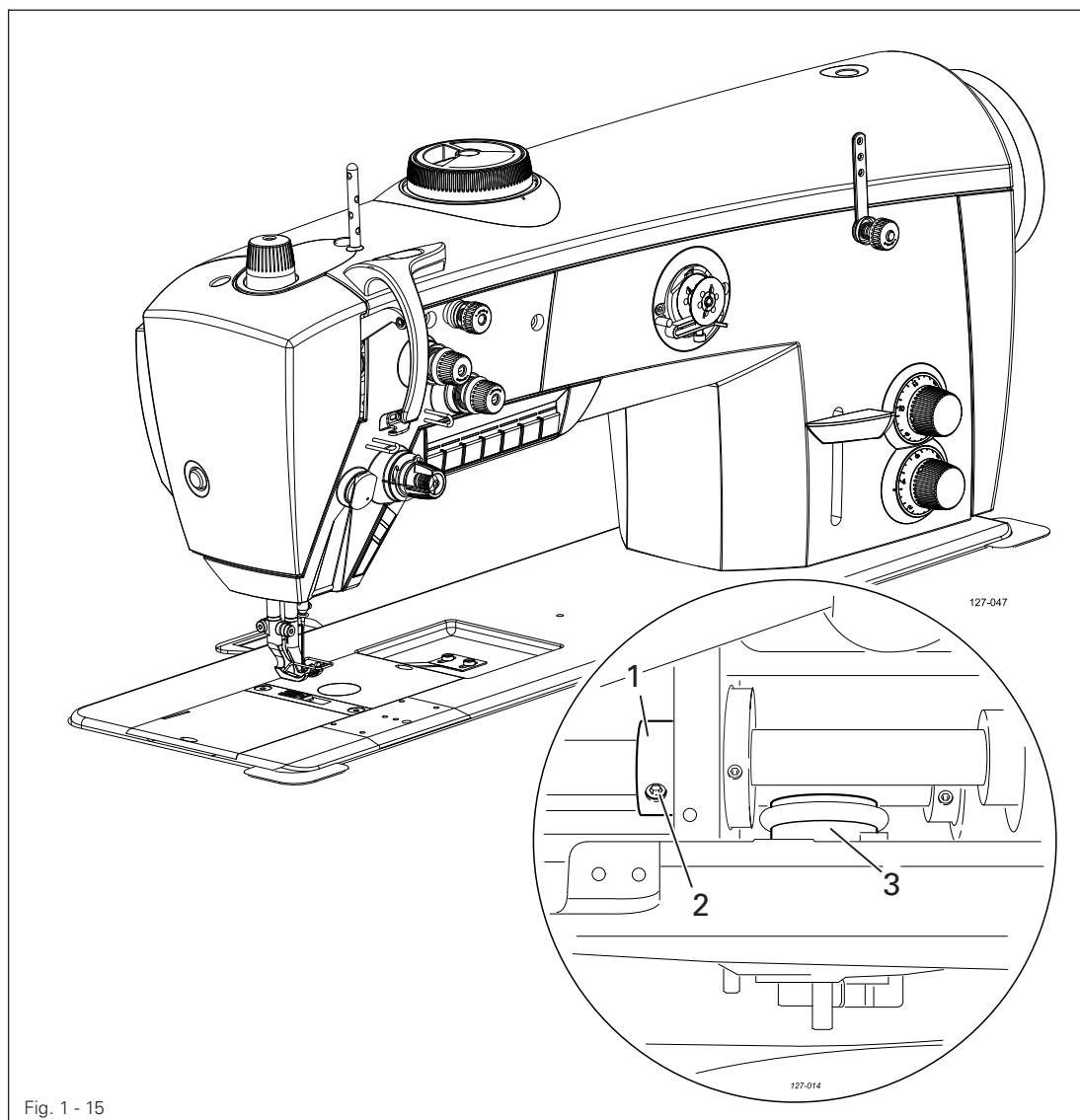
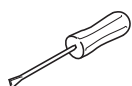

Fig. 1 - 15



- Adjust drive wheel **1** (screw **2**) in accordance with the requirement.

## 1.05.16 Thread check spring and thread regulator

### Requirement

1. The movement of thread regulator **3** must be completed when the needle point enters the material.
2. When the thread loop is at its largest while being passed around the hook, the check thread spring **3** should rise slightly from the rest **1**.

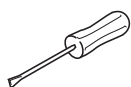
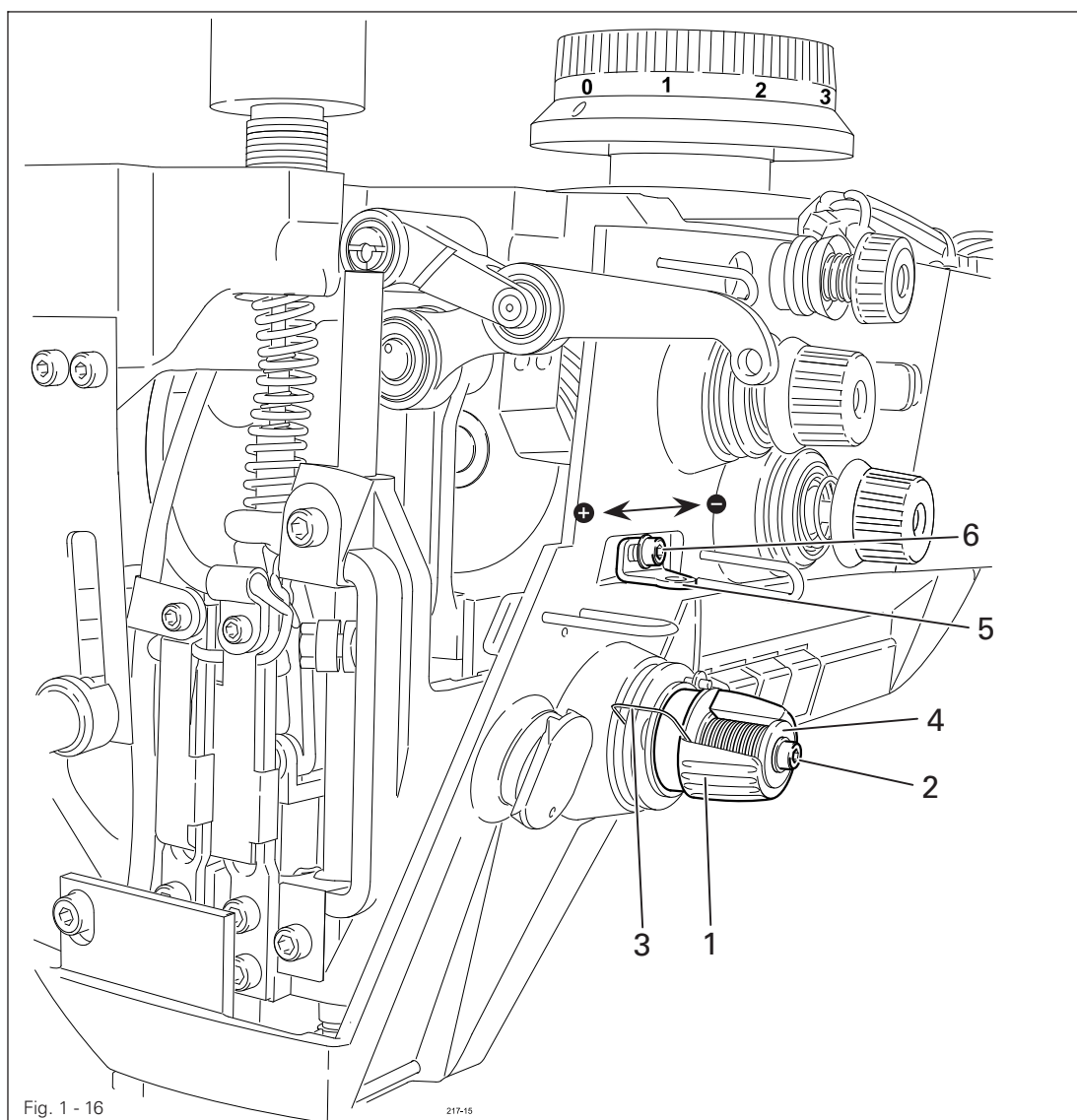

- Position rest **1** (screw **2**) in accordance with **requirement 1**.
- Turn sleeve **4** (screw **2**) to adjust the tension of thread check spring **3**.
- Position thread regulator **5** (screw **6**) in accordance with **requirement 2**.



For technical reasons it may be necessary to deviate from the indicated spring stroke or spring tension.

Move thread regulator **5** (screw **6**) towards ("**+**") (= more thread) or ("**-**") (= less thread).

## 1.05.17 Sewing foot pressure

### Requirement

The material should be fed properly even at maximum speed and with the smallest stroke.

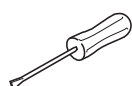
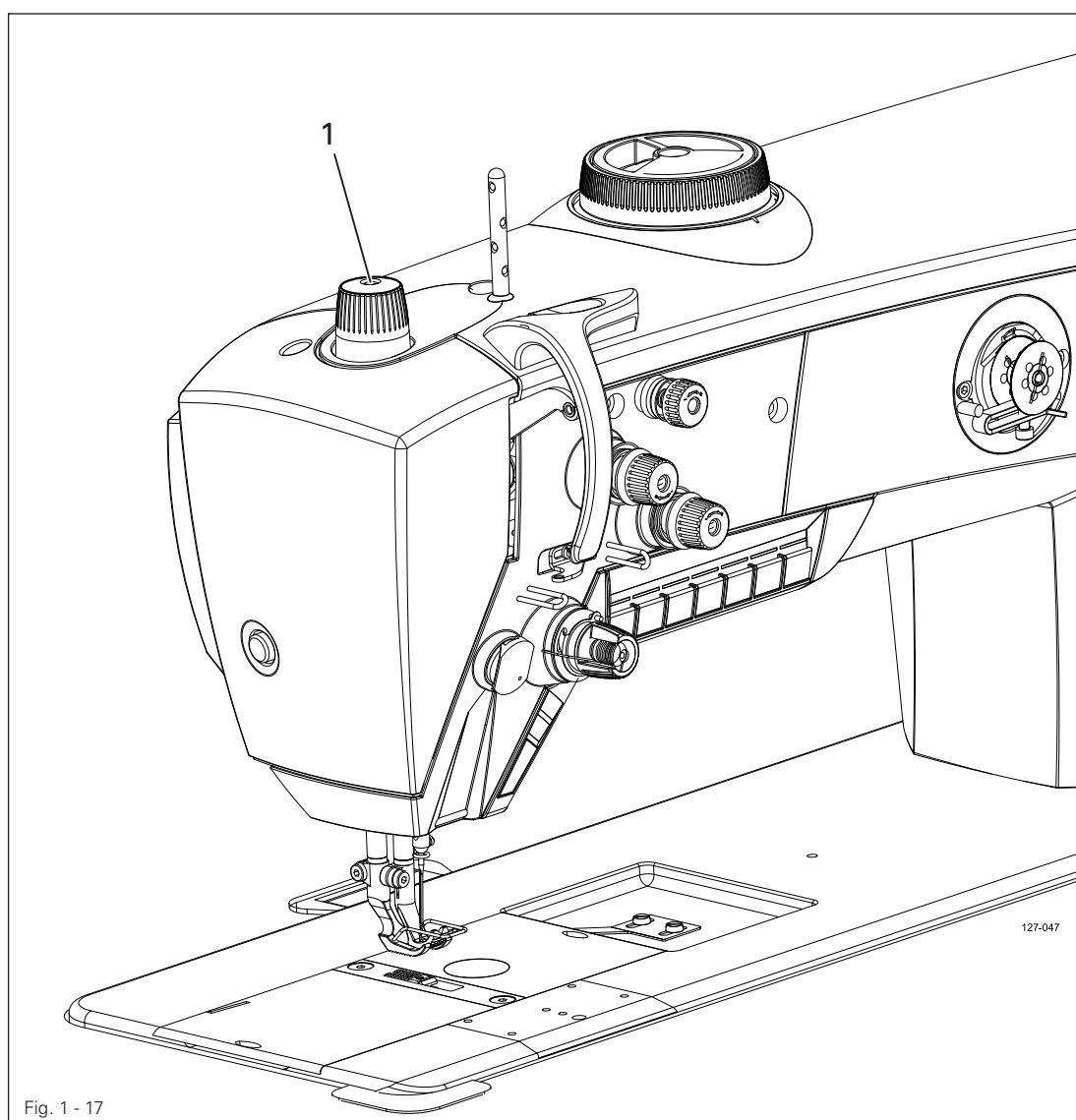

- Turn adjustment wheel 1 in accordance with the requirement.

## 1.05.18 Lubrication

### Requirement

After a running time of **10** seconds a thin film of oil should be visible on paper strip **1** when this is held over the hook.

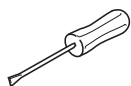
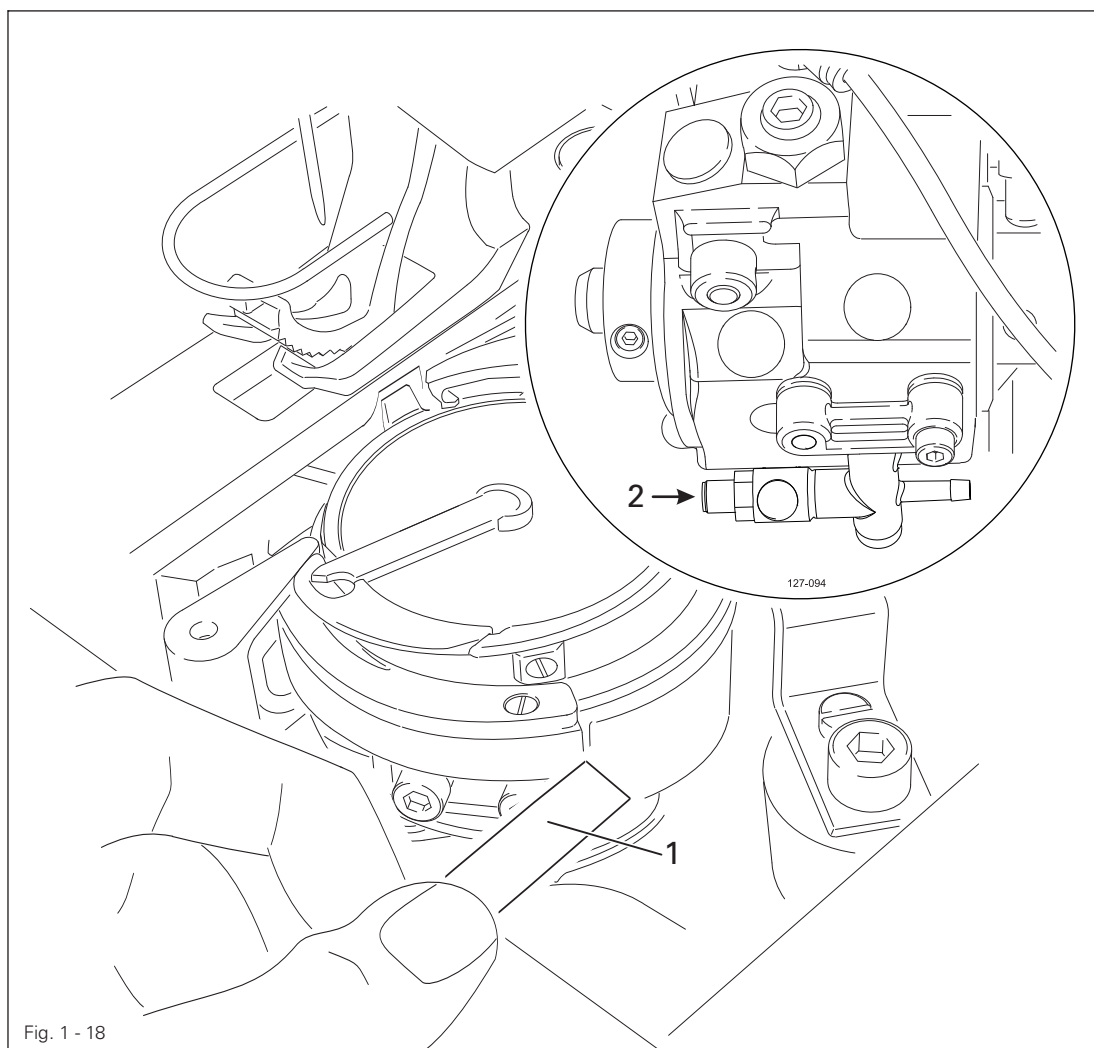

- Check that the machine is filled with oil and that the oil lines are free of air.
- Run the machine for **2 – 3 min.**



Do not put your hands into the needle area when the machine is running!  
Danger of injury from moving parts!

- With the machine running, hold paper strip **1** against the hook and check the **requirement**.
- If necessary, regulate amount of oil with screw **2**.



## 1.05.19 Limiting the stitch length



When exchanging the parts kit with stitch lengths differing from the as-delivered state of the machine, limit the max. stitch length using stitch adjuster 4.

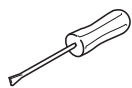
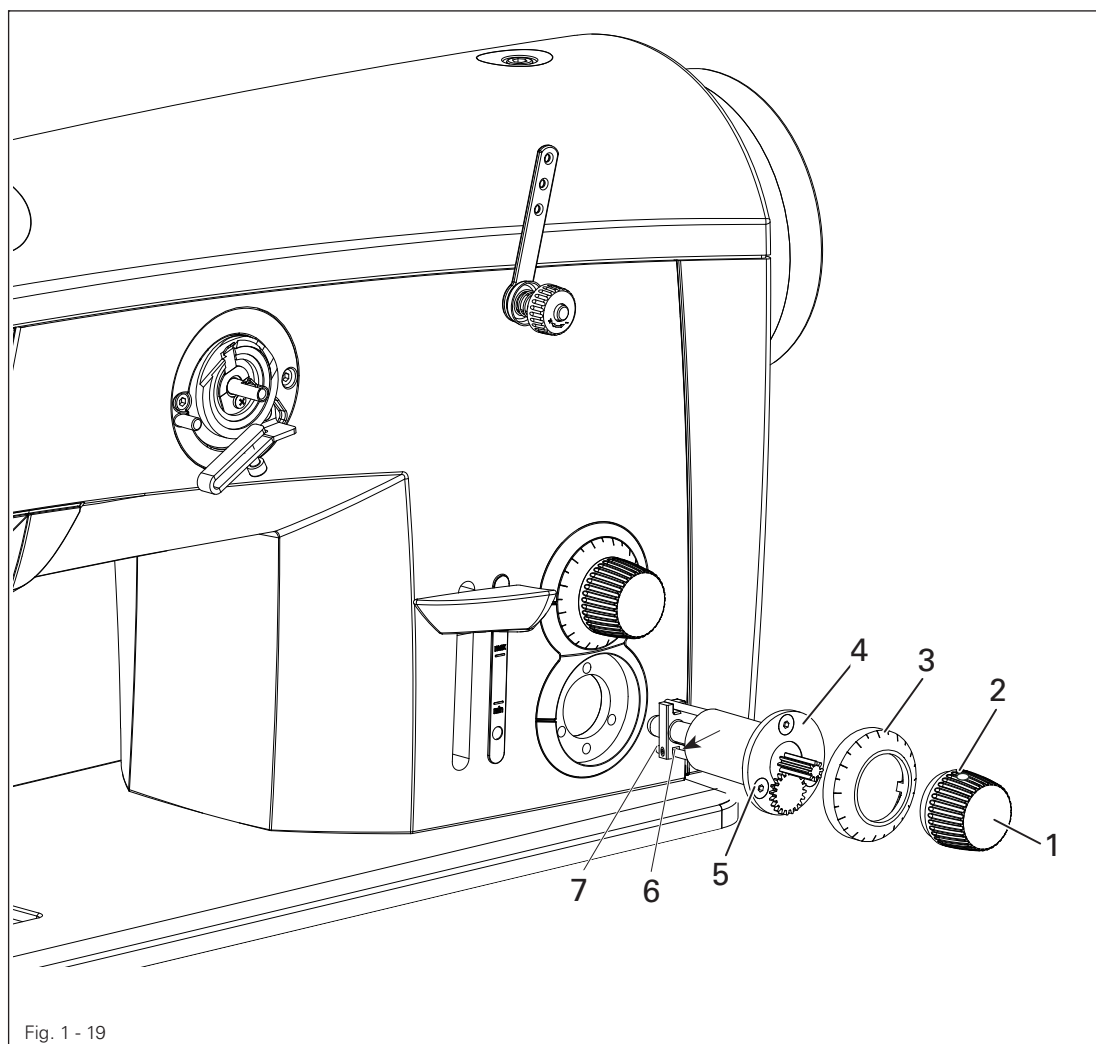

- Set the desired max. stitch length at control button 1 (on model CN9 = 9.0 mm, on model DN12 = 12 mm)
- Remove adjustment knob 1 (screws 2) and scale dial 3.
- Remove adjustment unit 4 (screws 5).
- Bring lineal 6 (screw 7) to the unit using stitch adjuster 4 (see arrow).
- Replace adjustment unit 4, scale dial 3 and adjustment knob 1.

## 1.05.20 Speed reduction

### Requirement

If a stitch length longer than 9 mm is set, the speed reduction switch 3 must be pressed.

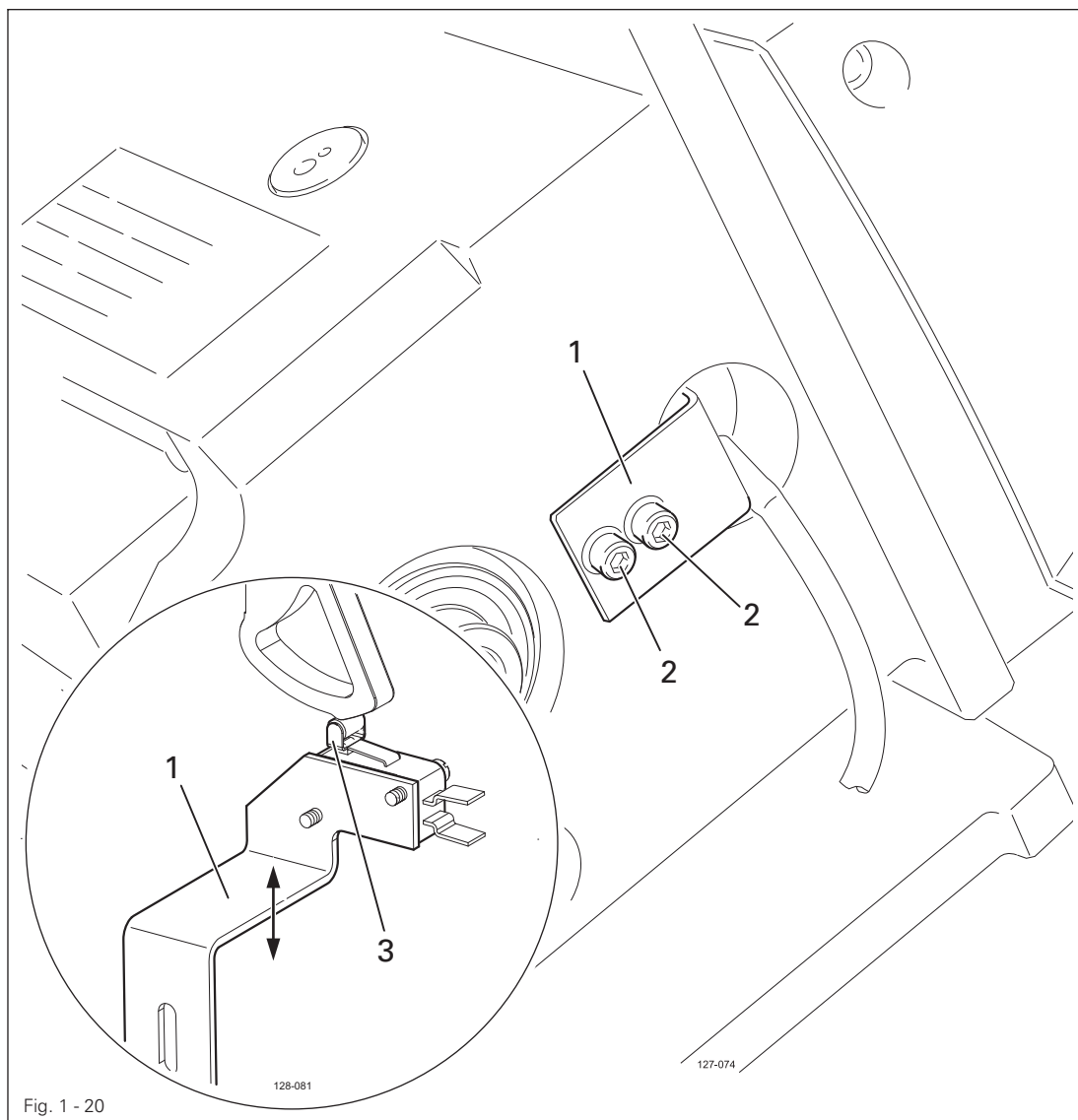
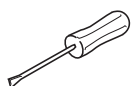

Fig. 1 - 20



- Adjust retaining plate 1 (screws 2) in accordance with the requirement.

## 1.05.21 Re-engaging the slip-clutch



Clutch 1 is adjusted at the works. In the case of a thread jamming, clutch 1 will disengage, in order to avoid damage to the hooks.  
The following describes how to re-engage clutch 1.

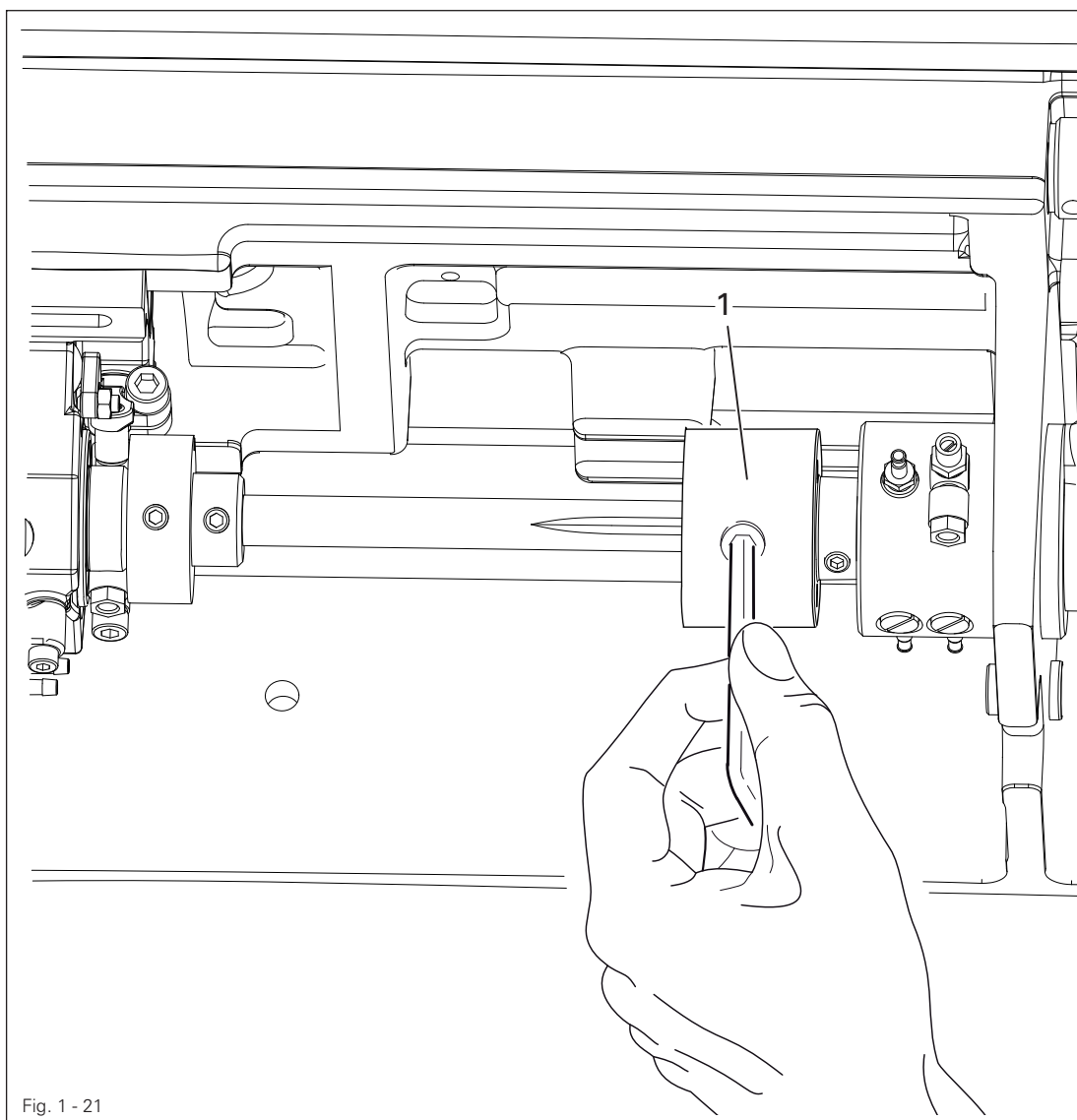

Fig. 1 - 21

- Remedy jammed thread fault.
- Hold clutch 1 firmly, as shown in Fig. 13-22, and turn the balance wheel until clutch 1 re-engages.

## Adjustment

### 1.06 Adjusting the thread trimmer -900/81

#### 1.06.01 Resting position of roller lever/radial position of control cam

##### Requirement

1. When the take-up lever is at t.d.c. (balance wheel position  $60^\circ$ ), control cam 1 should just have moved roller lever 5 into its basic position.
2. When the thread trimmer is in its resting position, there should be a clearance of **0.1 mm** between roller lever 5 and control cam 1.

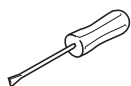
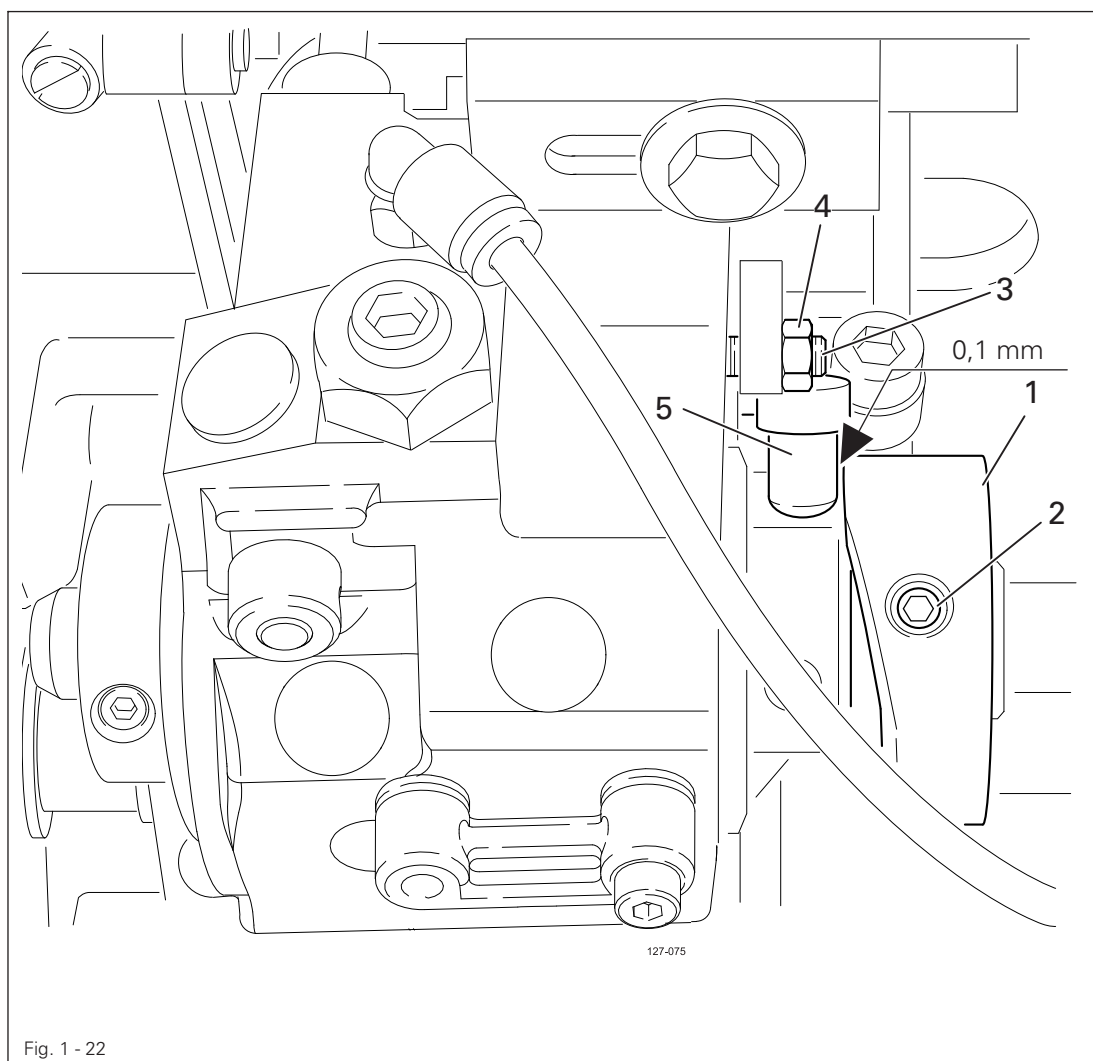

- Adjust control cam 1 (screws 2) in accordance with **requirement 1**.
- Adjust screw 3 (nut 4) in accordance with **requirement 2**.

## 1.06.02 Position and height of the thread catcher

### Requirement

When the needle bar is positioned at b.d.c. (balance wheel position 180°) the edges of thread catcher 3 and knife 5 should be flush (see arrow).

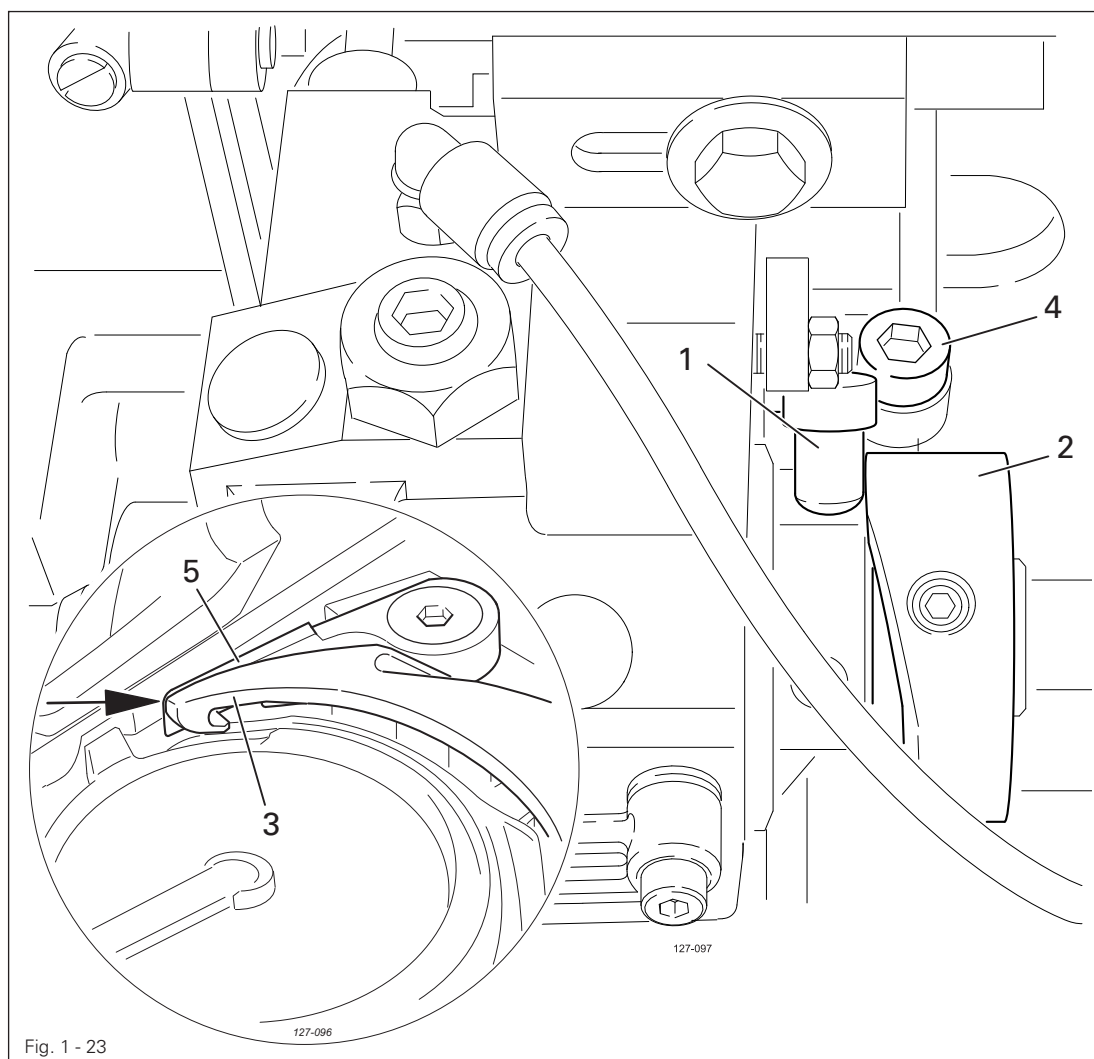
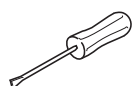

Fig. 1 - 23



- Press roller lever 1 against control cam 2.
- Adjust thread catcher 3 (screw 4) in accordance with the **requirement**



The height of thread catcher 3 is pre-set by the manufacturer and, if necessary, it can be adjusted with washers under thread catcher 3 on the base of the hook bearing.

## 1.06.03 Knife pressure

### Requirement

When the front edge of thread catcher 3 is 5 – 6 mm in front of the knife blade, the knife 4 should be touching the catcher edge with slight pressure.

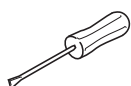
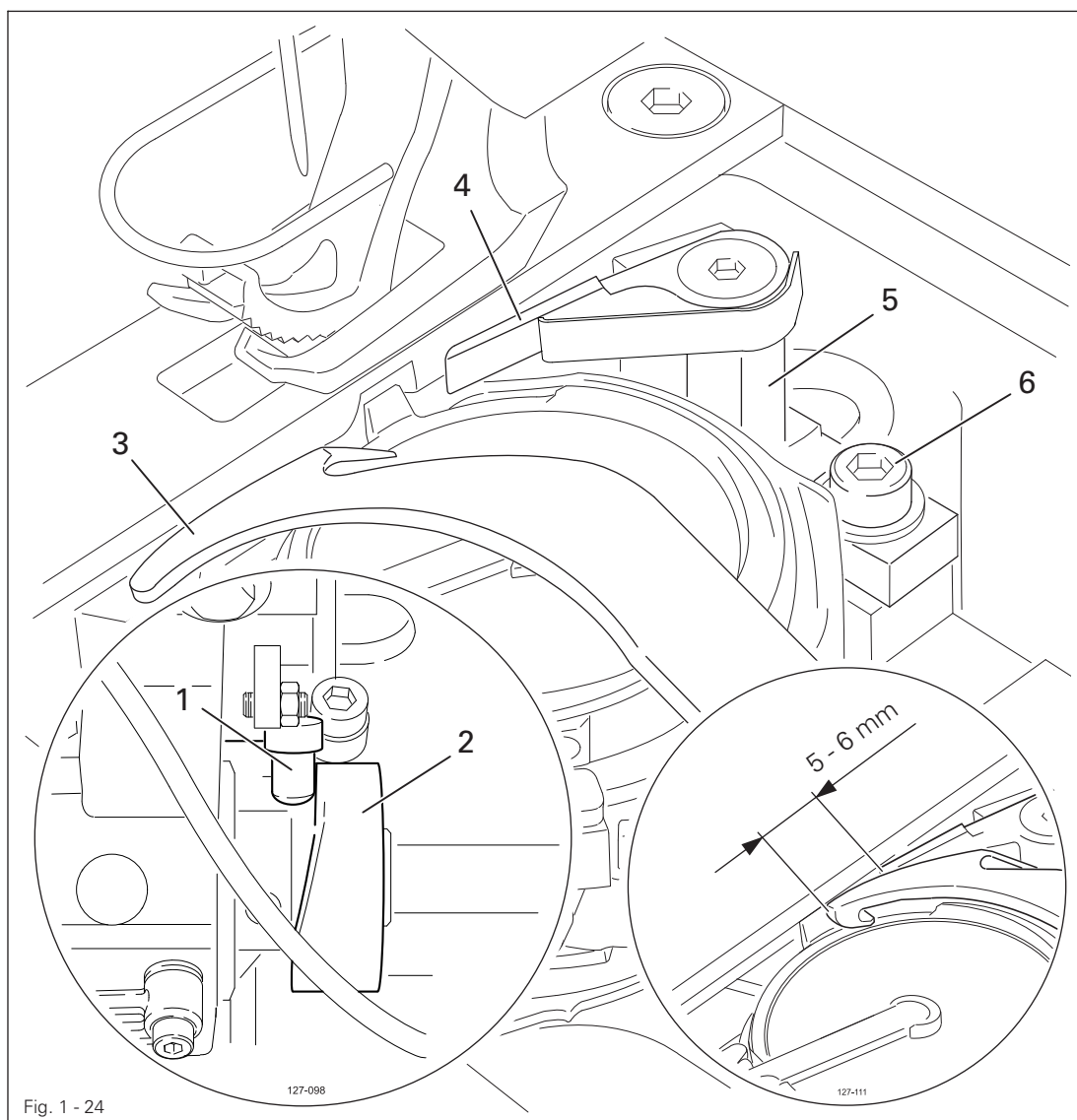

- Bring the take-up lever to its b.d.c and press roller lever 1 into the control cam 2.
- Turn the balance wheel until the front edge of catcher 3 is at a distance of 5 – 6 mm from the blade of knife 4.
- Swing knife bearing 5 (screw 6) in accordance with the **requirement**.



After completing the adjustment, recheck the position of the thread catcher in accordance with Chapter 1.06.02 **Position and height of the thread catcher**.

## 1.06.04 Bobbin thread clamp spring

### Requirement

When the thread trimmer is in its cutting position, the clamp spring should slightly touch the thread catcher and hold the thread reliably.

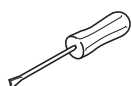
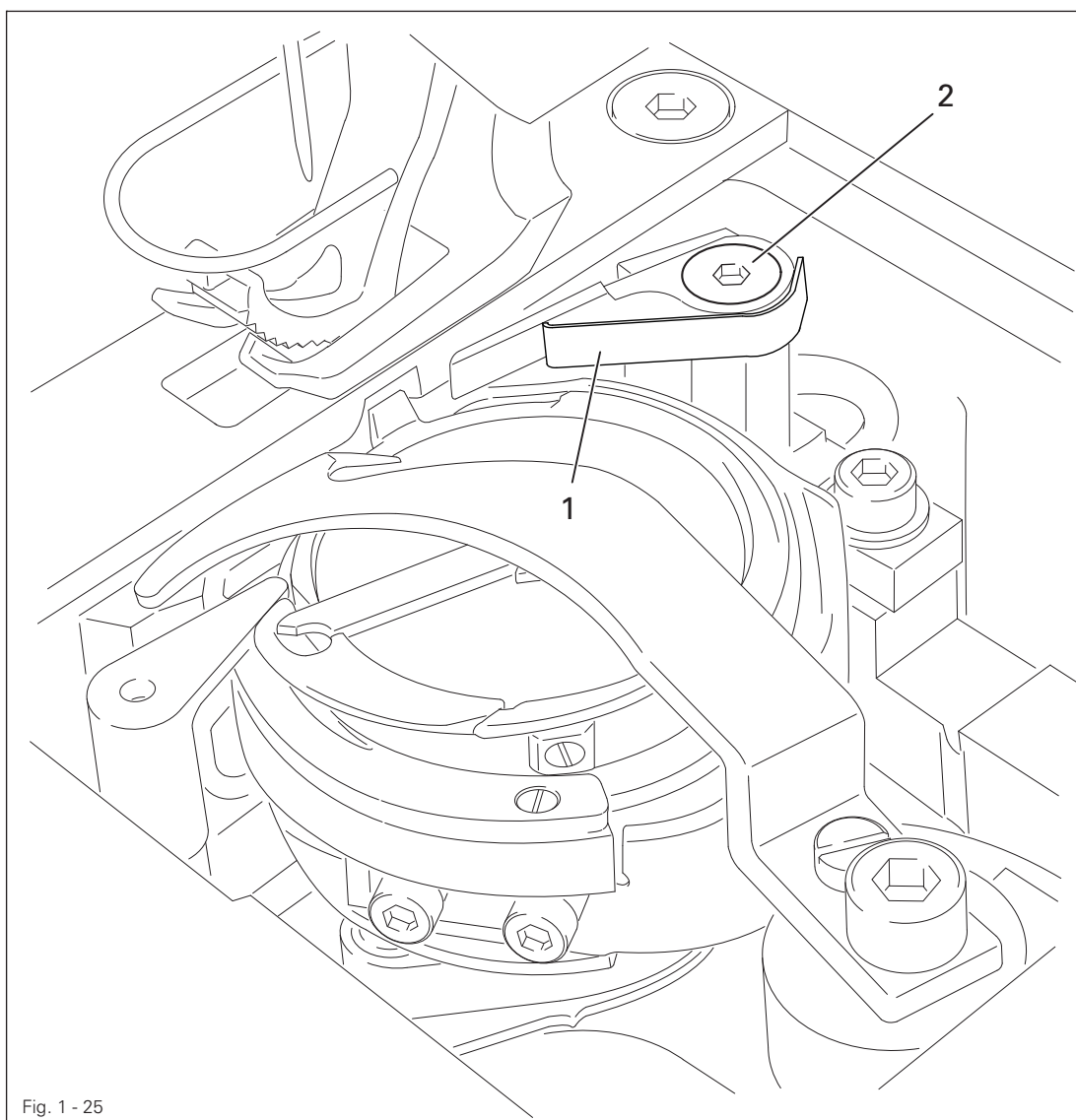

- Adjust clamp spring 1 (screw 2) in accordance with the **requirement**.
- Carry out the cutting operation by hand and check the setting. Readjust if necessary.

## 1.06.05 Manual cutting test

### Requirement

1. When moving forward, thread catcher 1 must not move bobbin thread 3
2. When thread catcher 1 is at its front point of reversal, bobbin thread 3 should be in the centre of the marked area (see arrow).
3. After the cutting operation has been completed, needle and bobbin thread should be cut neatly and bobbin thread 3 held.

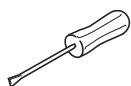
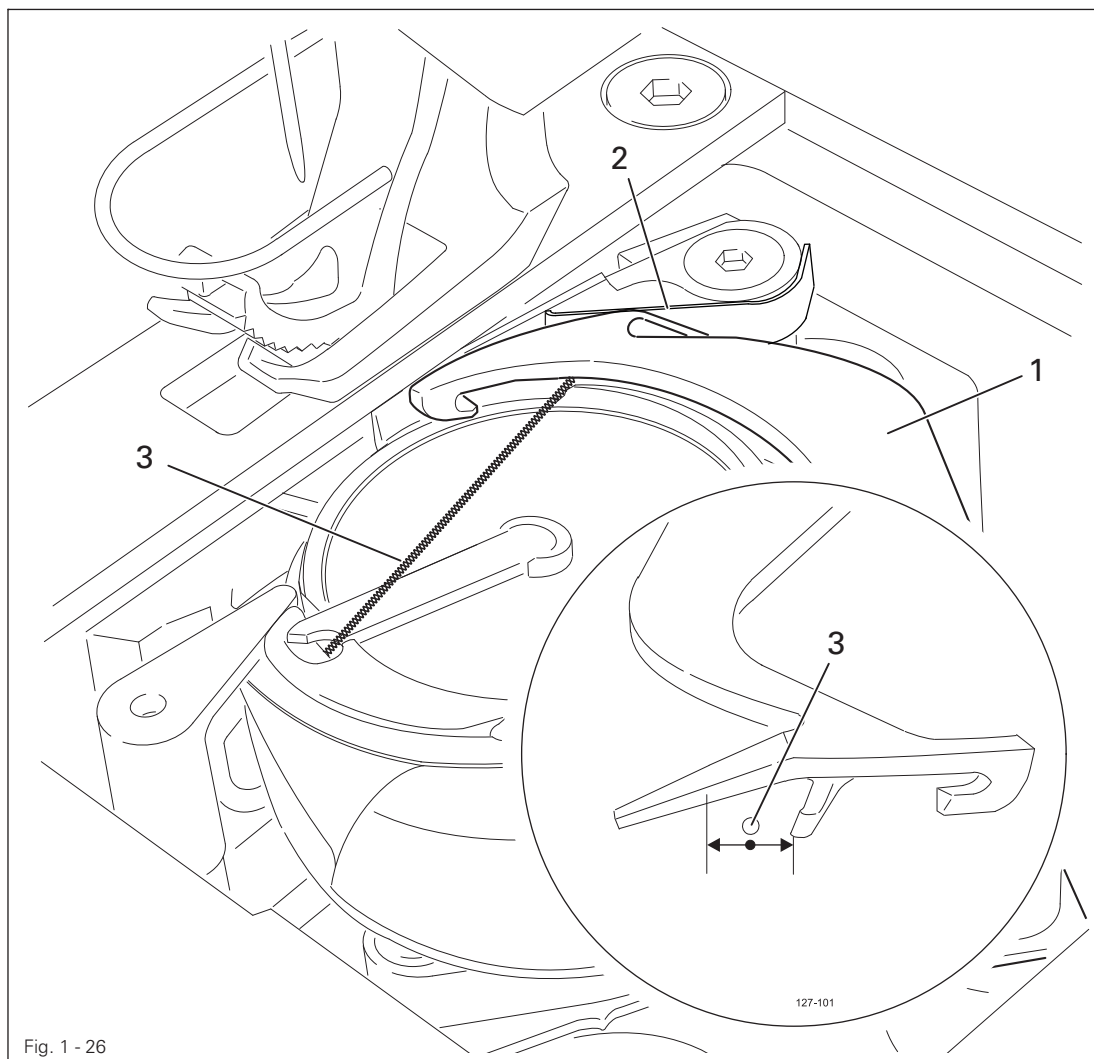

- Sew a few stitches.
- Switch off the main switch and the compressed air.
- Carry out a manual cutting test.
- Check **requirement 1**. If necessary, readjust thread catcher 1 in accordance with Chapter 1.06.02 **Position and height of the thread catcher**.
- Check **requirement 3**. If necessary, readjust bobbin thread clamp spring 2 in accordance with Chapter 1.06.04 **Bobbin thread clamp spring**.





Consult the instruction manual for the drive for a description of the parameter settings and a list of the parameters.

2 Block diagram PFAFF 2545/46 PLUS with PF 321

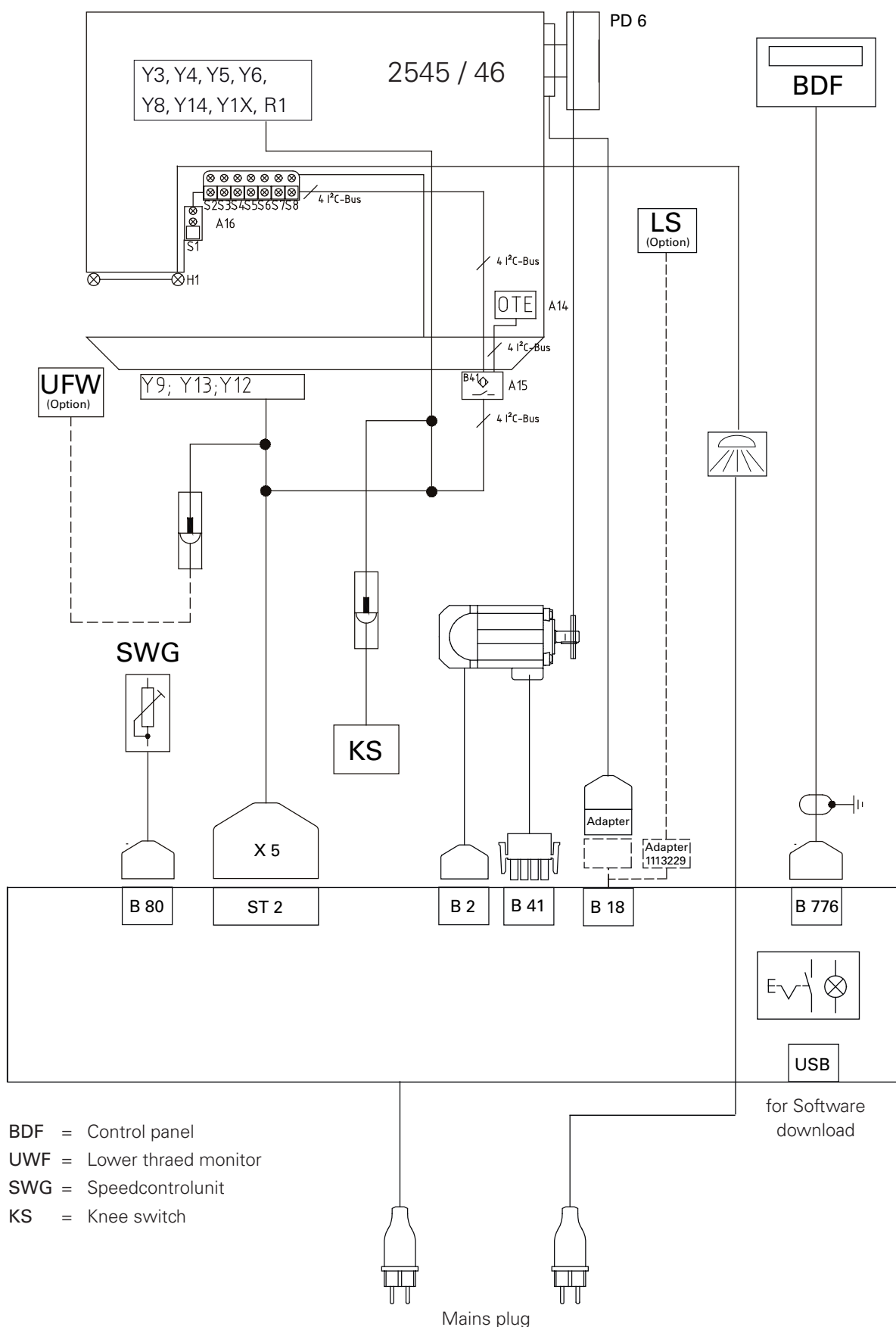





**Europäische Union**  
Wachstum durch Innovation – EFRE



## PFAFF Industriesysteme und Maschinen AG

Hans-Geiger-Str. 12 - IG Nord  
D-67661 Kaiserslautern

Phone: +49-6301 3205 - 0  
Fax: +49-6301 3205 1386  
E-mail: [info@pfaff-industrial.com](mailto:info@pfaff-industrial.com)

### Hotlines:

Technical service: +49-175/2243-101  
Application consultancy: +49-175/2243-102  
Spare-parts hotline: +49-175/2243-103

Printed in Germany

[www.promelectroavtomat.ru](http://www.promelectroavtomat.ru)