

# 335

## INSTRUCTION MANUAL

This instruction manual applies to machines from the following serial numbers onwards:

# 2 734 226 →



This Instruction Manual is valid for all models and subclasses listed in the chapter "**Specifications**".



The adjustment manual for the machines can be downloaded free of charge from the internet address

**[www.pfaff-industrial.com/pfaff/de/service/downloads](http://www.pfaff-industrial.com/pfaff/de/service/downloads)**

As an alternative to the internet download the adjustment manual can also be ordered in book form under part no. **296-12-18 642/002**.

The reprinting, copying or translation of PFAFF Instruction Manuals, whether in whole or in part, is only permitted with our previous authorization and with written reference to the source.

**PFAFF Industriesysteme  
und Maschinen AG**

Hans-Geiger-Str. 12 - IG Nord  
D-67661 Kaiserslautern

|             | Contents .....  | Page      |
|-------------|---|-----------|
| <b>1</b>    | <b>Safety .....</b>   | <b>5</b>  |
| <b>1.01</b> | <b>Directives .....</b>                                       | <b>5</b>  |
| 1.02        | General notes on safety.....                                  | 5         |
| 1.03        | Safety symbols .....  | 6         |
| 1.04        | Important points for the user .....                           | 6         |
| 1.05        | Operating and specialist personnel.....                       | 7         |
| 1.05.01     | Operating personnel .....                                     | 7         |
| 1.05.02     | Specialist personnel .....                                    | 7         |
| 1.06        | Danger warnings.....  | 8         |
| <b>2</b>    | <b>Proper use .....</b>                                       | <b>9</b>  |
| <b>3</b>    | <b>Specifications .....</b>                                   | <b>10</b> |
| 3.01        | PFAFF 335.....  | 10        |
| 3.02        | Versions and subclasses .....                                 | 10        |
| <b>4</b>    | <b>Disposal of Machine .....</b>                              | <b>11</b> |
| <b>5</b>    | <b>Transportation, packing and storage .....</b>              | <b>12</b> |
| 5.01        | Transportation to customer's premises .....                   | 12        |
| 5.02        | Transportation inside the customer's premises.....            | 12        |
| 5.03        | Disposal of packing materials .....                           | 12        |
| 5.04        | Storage .....   | 12        |
| <b>6</b>    | <b>Explanation of symbols .....</b>                           | <b>13</b> |
| <b>7</b>    | <b>Controls .....</b>   | <b>14</b> |
| 7.01        | On/off switch .....   | 14        |
| 7.02        | Pedale .....  | 14        |
| 7.03        | Lever for lifting the presser foot .....                      | 15        |
| 7.04        | Stitch-length adjustment lever / reverse sewing.....          | 15        |
| 7.05        | Adjustment nut for the top-feed stroke .....                  | 16        |
| 7.06        | Control panel (only on machines with Quick EcoDrive) .....    | 16        |
| <b>8</b>    | <b>Installation and commissioning .....</b>                   | <b>17</b> |
| 8.01        | Installation.....   | 17        |
| 8.01.01     | Adjusting the table-top height.....                           | 17        |
| 8.01.02     | Assembling the motor (only on machines with Quick-motor)..... | 18        |
| 8.01.03     | Tightening the V-belt .....                                   | 18        |
| 8.01.04     | Mounting the bottom V-belt guard .....                        | 19        |
| 8.01.05     | Fitting the upper belt guard.....                             | 20        |
| 8.01.06     | Fitting the synchronizer .....                                | 20        |
| 8.01.07     | Fitting the reel stand.....                                   | 21        |
| 8.01.08     | Connecting the plug-in connections and earth cables .....     | 22        |

|           | Contents .....   | Page      |
|-----------|--|-----------|
|           | Contents .....   | Page      |
| 8.02      | Commissioning .....  | 23        |
| 8.03      | Switching the machine on/off .....   | 23        |
| 8.04      | Basic position of the machine drive unit .....                             | 24        |
| <b>9</b>  | <b>Setting up .....</b>  | <b>25</b> |
| 9.01      | Inserting the needle .....   | 25        |
| 9.02      | Winding the bobbin thread, adjusting the thread tension.....               | 26        |
| 9.03      | Removing / Inserting the bobbin case .....                                 | 27        |
| 9.04      | Threading the bobbin thread and regulating the bobbin thread tension ..... | 27        |
| 9.05      | Threading needle thread/adjusting needle thread tension .....              | 28        |
| 9.06      | Adjusting the stitch counter for the bobbin thread control.....            | 29        |
| <b>10</b> | <b>Care and maintenance.....</b>   | <b>30</b> |
| 10.01     | Care and maintenance intervals.....  | 30        |
| 10.02     | Cleaning .....   | 30        |
| 10.03     | General oiling .....   | 31        |
| 10.04     | Oiling the sewing hook .....   | 32        |
| 10.05     | Oiling the needle-head parts.....  | 32        |
| 10.06     | Lubricating the bevel gears.....   | 33        |
| 10.07     | Lubricating the top-feed drive excentric.....                              | 34        |
| 10.08     | Checking/regulating the air pressure .....                                 | 34        |
| 10.09     | Emptying/cleaning the water bowl of the air filter/regulator .....         | 35        |
| 10.10     | Parameter settings .....   | 36        |
| 10.10.01  | Parameter list .....   | 36        |
| <b>11</b> | <b>Table top cutout and circuit diagrams.....</b>                          | <b>37</b> |
| 11.01     | Table top cutout .....   | 37        |
| 11.02     | Mounting the table top .....   | 37        |
| 11.03     | Circuit diagrams .....   | 38        |
| <b>12</b> | <b>Wearing parts .....</b>   | <b>42</b> |

## 1 Safety

### 1.01 Directives

This machine is constructed in accordance with the European regulations contained in the conformity and manufacturer's declarations.

In addition to this Instruction Manual, also observe all generally accepted, statutory and other regulations and legal requirements and all valid environmental protection regulations! The regionally valid regulations of the social insurance society for occupational accidents or other supervisory organizations are to be strictly adhered to!

### 1.02 General notes on safety

- This machine may only be operated by adequately trained operators and only after having completely read and understood the Instruction Manual!
- All Notes on Safety and Instruction Manuals of the motor manufacturer are to be read before operating the machine!
- The danger and safety instructions on the machine itself are to be followed!
- This machine may only be used for the purpose for which it is intended and may not be operated without its safety devices. All safety regulations relevant to its operation are to be adhered to.
- When exchanging sewing tools (e.g. needle, roller presser, needle plate and bobbin), when threading the machine, when leaving the machine unattended and during maintenance work, the machine is to be separated from the power supply by switching off the On/Off switch or by removing the plug from the mains!
- Everyday maintenance work is only to be carried out by appropriately trained personnel!
- Repairs and special maintenance work may only be carried out by qualified service staff or appropriately trained personnel!
- Work on electrical equipment may only be carried out by appropriately trained personnel!
- Work is not permitted on parts and equipment which are connected to the power supply! The only exceptions to this rule are found in the regulations EN 50110.
- Modifications and alterations to the machine may only be carried out under observance of all the relevant safety regulations!
- Only spare parts which have been approved by us are to be used for repairs! We expressly point out that any replacement parts or accessories which are not supplied by us have not been tested and approved by us. The installation and/or use of any such products can lead to negative changes in the structural characteristics of the machine. We are not liable for any damage which may be caused by non-original parts.

## 1.03 Safety symbols



Danger!  
Points to be observed..



Danger of injury for operating and specialist personnel!



### Caution

Do not operate without finger guard and safety devices.  
Before threading, changing bobbin and needle, cleaning etc. **switch off main switch.**

## 1.04 Important points for the user

- This Instruction Manual is an integral part of the machine and must be available to the operating personnel at all times.
- The Instruction Manual must be read before operating the machine for the first time.
- The operating and specialist personnel is to be instructed as to the safety equipment of the machine and regarding safe work methods.
- It is the duty of the user to only operate the machine in perfect running order.
- It is the obligation of the user to ensure that none of the safety mechanisms are removed or deactivated.
- It is the obligation of the user to ensure that only authorized persons operate and work on the machine.

Further information can be obtained from your PFAFF agent.

## 1.05 Operating and specialist personnel

### 1.05.01 Operating personnel

Operating personnel are persons responsible for the equipping, operating and cleaning of the machine as well as for taking care of problems arising in the sewing area.

The operating personnel is required to observe the following points and must:

- always observe the Notes on Safety in the Instruction Manual!
- never use any working methods which could adversely affect the safety of the machine!
- not wear loose-fitting clothing or jewelery such as chains or rings!
- also ensure that only authorized persons have access to the potentially dangerous area around the machine!
- always immediately report to the person responsible any changes in the machine which may limit its safety!

### 1.05.02 Specialist personnel

Specialist personnel are persons with a specialist education in the fields of electrics, electronics and mechanics. They are responsible for the lubrication, maintenance, repair and adjustment of the machine.

The specialist personnel is obliged to observe the following points and must:

- always observe the Notes on Safety in the Instruction Manual!
- switch off the On/Off switch before carrying out adjustments or repairs, and ensure that it cannot be switched on again unintentionally!
- wait until the luminous diode on the control box is no longer blinking or on before beginning adjustment or repair work.
- never work on parts which are still connected to the power supply! Exceptions are explained in the regulations EN 50110.
- replace the protective coverings and close the electrical control box after all repairs or maintenance work!

## 1.06

### Danger warnings



A working area of 1 m must be kept free both in front of and behind the machine, so that easy access is possible at all times.



Never put your hands or fingers in the sewing area during sewing!  
Danger of injury by the needle!



While setting or adjusting the machine do not leave any objects on the table nor in the needle plate area! Objects may be trapped or flung out of the machine!

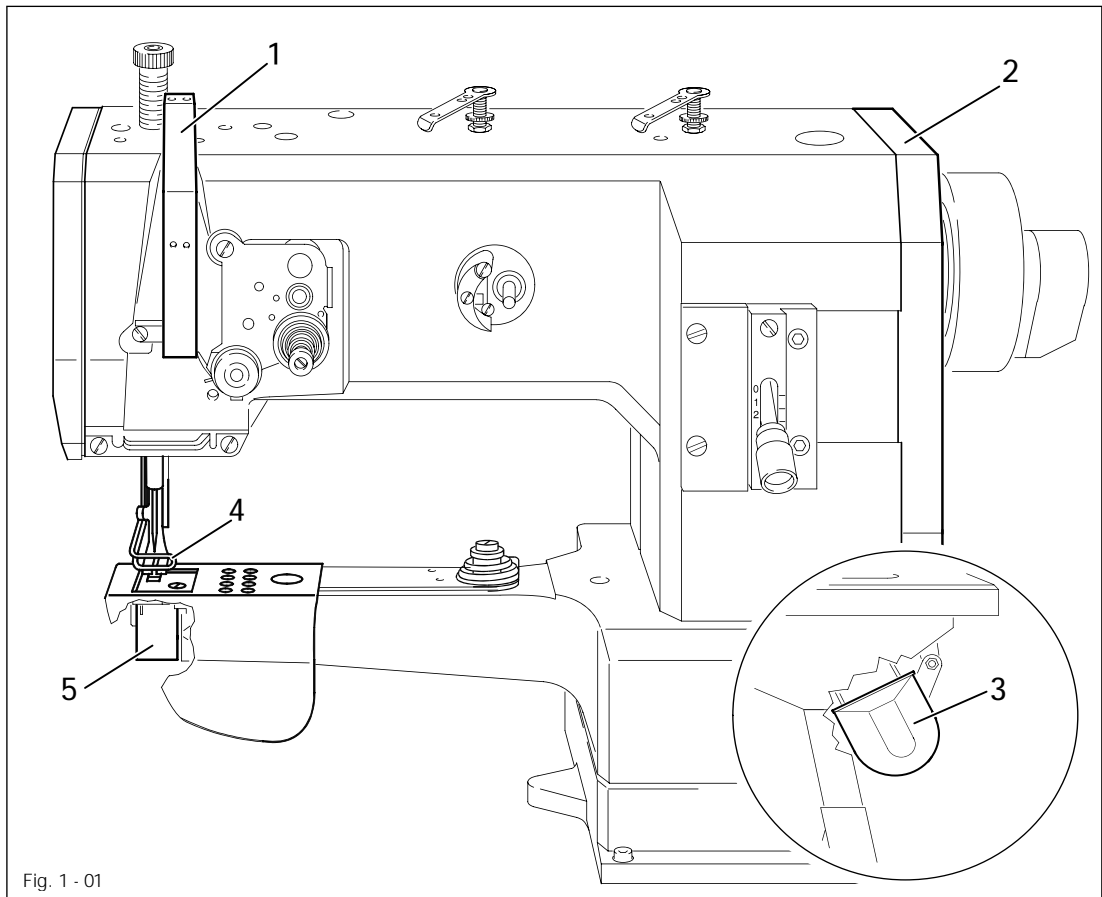

Fig. 1 - 01



Do not run the machine without take-up lever guard 1!  
Danger of injury by moving take-up lever!



Do not run the machine without belt guards 2 and 3!  
Danger of injury by rotating v-belt!



Do not run the machine without finger guard 4!  
Danger of injury by up and down movement of needle!



Do not run the machine without cylinder-bed cap 5!  
Danger of injury by rotating hook!



## Proper use

The PFAFF 335 is a single needle, free-arm sewing machine with bottom, top and needle feeds for sewing lockstitch seams.



Any and all uses of this machine which have not been approved of by the manufacturer are considered to be inappropriate! The manufacturer cannot be held liable for any damage caused by the inappropriate use of the machine! The appropriate use of the machine includes the observance of all operational, adjustment, maintenance and repair measures required by the manufacturer!

## 3 Specifications

### 3.01 PFAFF 335 ♦

Stitch type: ..... 301 ( lockstitch)  
Model: ..... B  
Needle system: ..... 134 - 35  
Needle thickness (Nm) in 1/100 mm: ..... 80 - 100

Max. stitch length:  
on sub classes -940/01-6/01 ..... 4,5 mm  
on sub classes -2/27; -6/01; -17/01; -39/21 ..... 6,0 mm  
on sub classes -900/52 ..... 5,5 mm

Handwheel effective dia.: ..... 80 mm  
Max. speed: ..... 2800 spm  
Dimensions of the machine:  
Free-arm head dia.: ..... 51 mm  
Free-arm size: ..... approx. 165 mm  
Length: ..... approx. 770 mm  
Width: ..... approx. 380 mm  
Height: ..... approx. 630 mm

Width of fabric clearance: ..... 265 mm  
Height of fabric clearance: ..... 115 mm  
Clearance under the sewing foot: ..... 7 mm

Net weight (sewing head): ..... approx. 40 kg  
Working air pressure: ..... 6 bar  
Air consumption: ..... ~0.8 l / work cycle

Motor data: ..... see motor specification plate  
Noise data:  
Emission sound level at workplace at a speed of 1800 spm: .....  $L_{pA} = 81.0 \text{ dB(A)}$  ■  
(Noise measurement in accordance with DIN 45 635-48-B-1, ISO 11204, ISO 3744, ISO 4871)

### 3.02 Versions and subclasses

Version B: ..... for sewing medium-weight materials  
Version P: ..... additional lifting phase of the bottom feed dog

Additional equipment:  
Subclass -900/52 ..... Thread trimmer  
Subclass -911/97 ..... Backtacking device

♦ Subject to alterations

■  $K_{pA} = 2,5 \text{ dB}$

### 4 Disposal of Machine

- Proper disposal of the machine is the responsibility of the customer.
- The materials used for the machine are steel, aluminium, brass and various plastic materials. The electrical equipment comprises plastic materials and copper.
- The machine is to be disposed of according to the locally valid pollution control regulations; if necessary, a specialist is to be commissioned.



Care must be taken that parts soiled with lubricants are disposed of separately according to the locally valid pollution control regulations!

---

## *Transportation, packing and storage*

---

### 5 Transportation, packing and storage

#### 5.01 Transportation to customer's premises

The machines are delivered completely packed.

#### 5.02 Transportation inside the customer's premises

The manufacturer cannot be made liable for transportation inside the customer's premises nor to other operating locations. It must be ensured that the machines are only transported in an upright position.

#### 5.03 Disposal of packing materials

The packing materials of this machine comprise paper, cardboard and VCE fibre. Proper disposal of the packing material is the responsibility of the customer.

#### 5.04 Storage

If the machine is not in use, it can be stored as it is for a period of up to six months, but it should be protected against dust and moisture.

If the machine is stored for longer periods, the individual parts, especially the surfaces of moving parts, must be protected against corrosion, e.g. by a film of oil.

### 6 Explanation of symbols

In this instruction manual, work to be carried out or important information is accentuated by symbols. These symbols have the following meanings:



Note, information



Cleaning, care



Lubrication

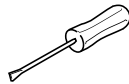

Maintenance, repairs, adjustment, service work  
(only to be carried out by technical staff)

## 7 Controls

### 7.01 On/off switch

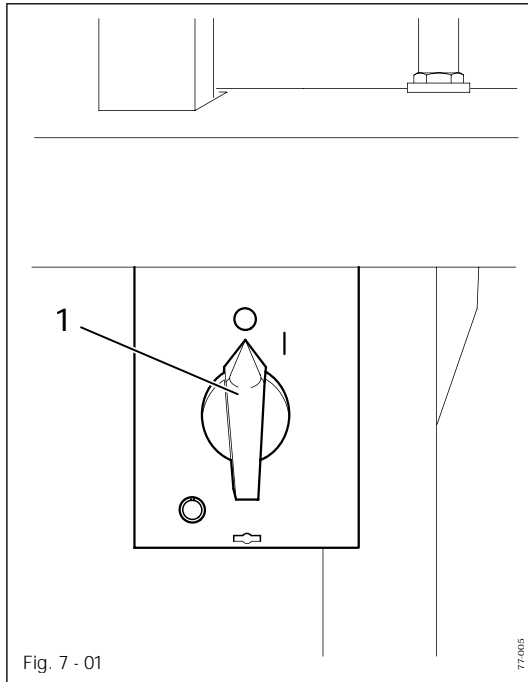

- The power supply to the machine is switched on or off by turning switch 1.



The illustrated on/off switch is fitted to machines with Quick motors. If other motors are used, a different switch may be fitted.

### 7.02 Pedale

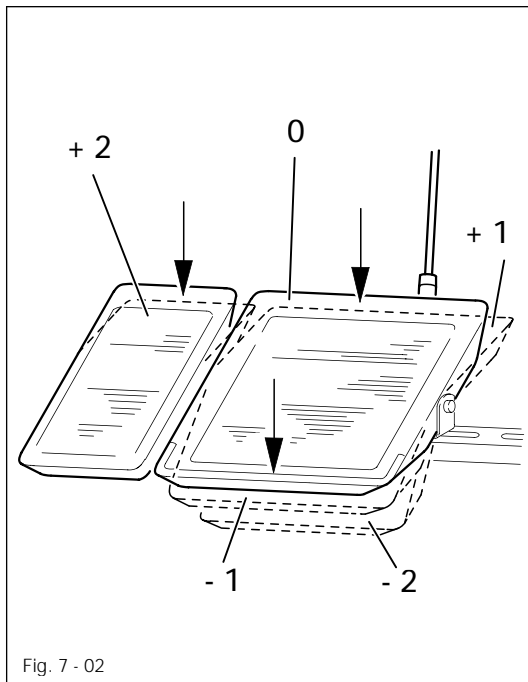

- With the on/off switch on
  - +1 = Sew
  - 1 = Raise presser foot (on machines with -911/97)
  - 2 = Trim thread (on machines with thread trimmer -900/52)
  - +3 = Raise presser foot (on machines without automatic presser-foot -911/97)

7.03 Lever for lifting the presser foot

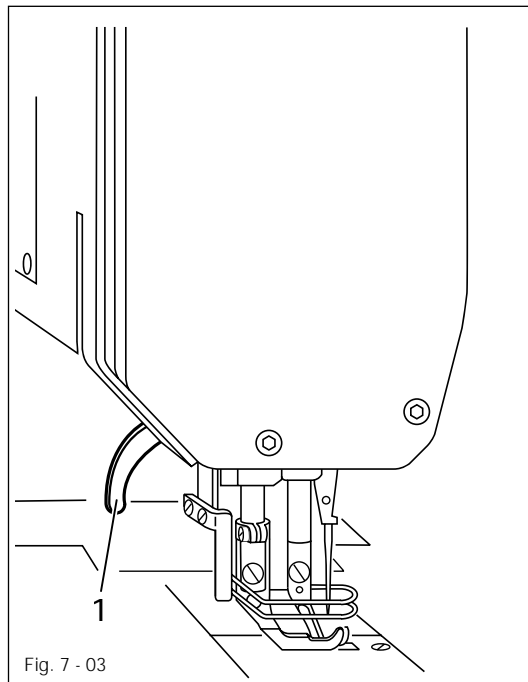

- The sewing foot can be lifted by raising lever 1.

7.04 Stitch-length adjustment lever / reverse sewing

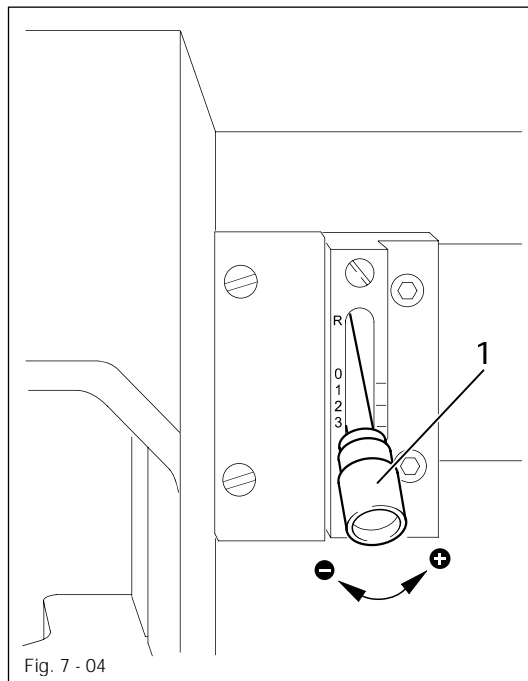

- Adjust the stitch length by turning the milled nut on lever 1 as required.

**Reverse sewing**

- For reverse sewing, push lever 1 up during sewing.

## 7.05 Adjustment nut for the top-feed stroke

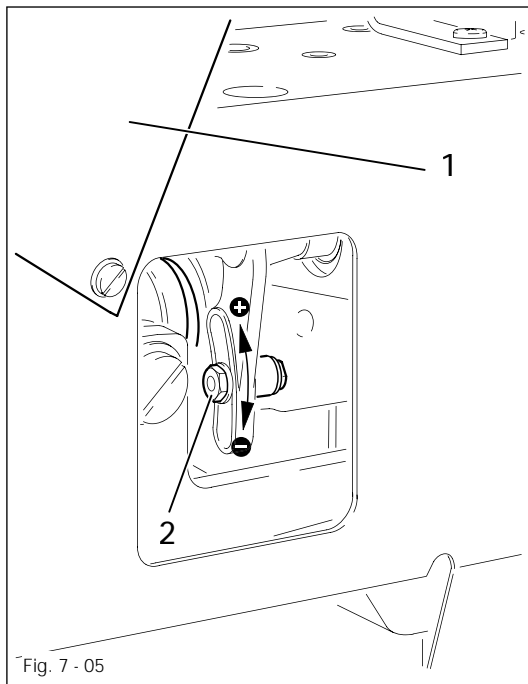

Switch the machine off!  
Danger due to unintentional starting of the machine!

- Open cover 1 on the back of the machine, loosen screw 2 and move as required.

## 7.06 Control panel (only on machines with Quick EcoDrive)

The description can be found in the separate instruction manual for the control panel.



## 8 Installation and commissioning



The machine must only be mounted and commissioned by qualified personnel!  
All relevant safety regulations are to be observed!

If the machine is delivered without a table, it must be ensured that the frame and the table top which you intend to use can hold the weight of the machine and the motor. It must be ensured that the supporting structure is sufficiently sturdy, including during all sewing operations.

### 8.01 Installation

The site where the machine is installed must be provided with suitable connections for the electric current, see Chapter 3 Specifications.

It must also be ensured that the standing surface of the machine site is firm and horizontal, and that sufficient lighting is provided.



The method of packaging used requires that the table top be lowered for transport. The following is a description of how to adjust the height of the table top.

#### 8.01.01 Adjusting the table-top height

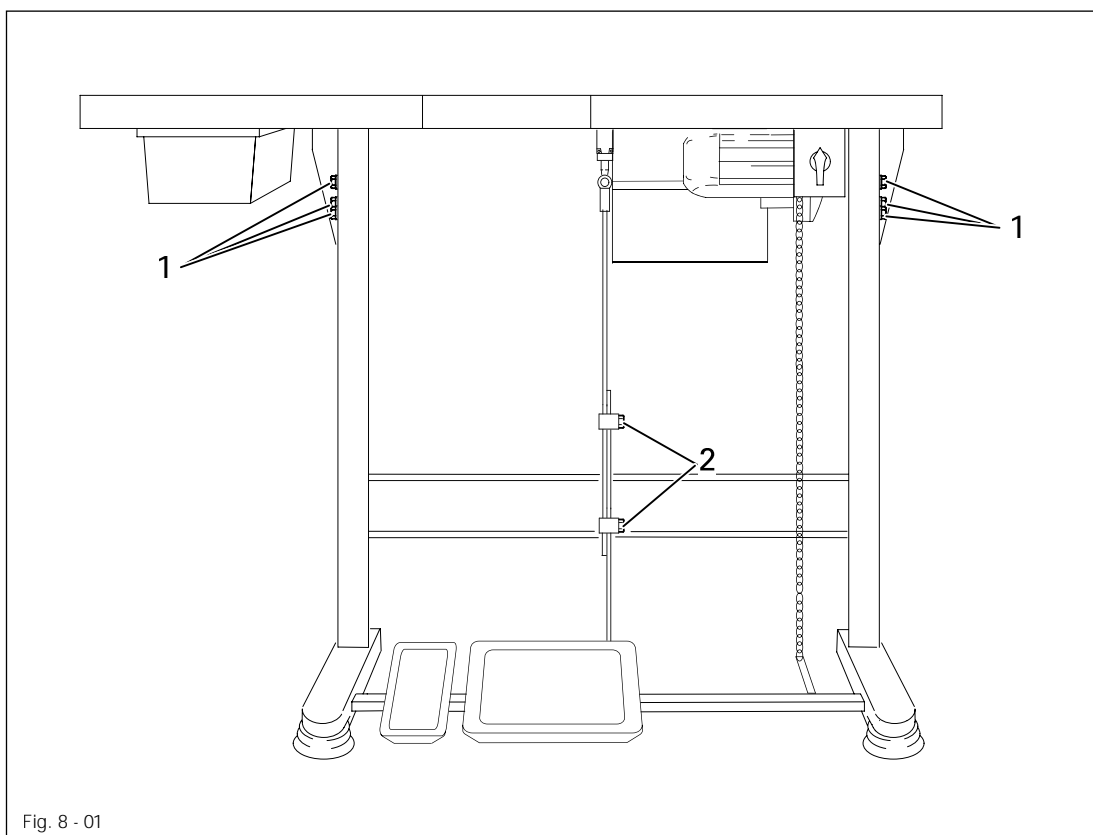
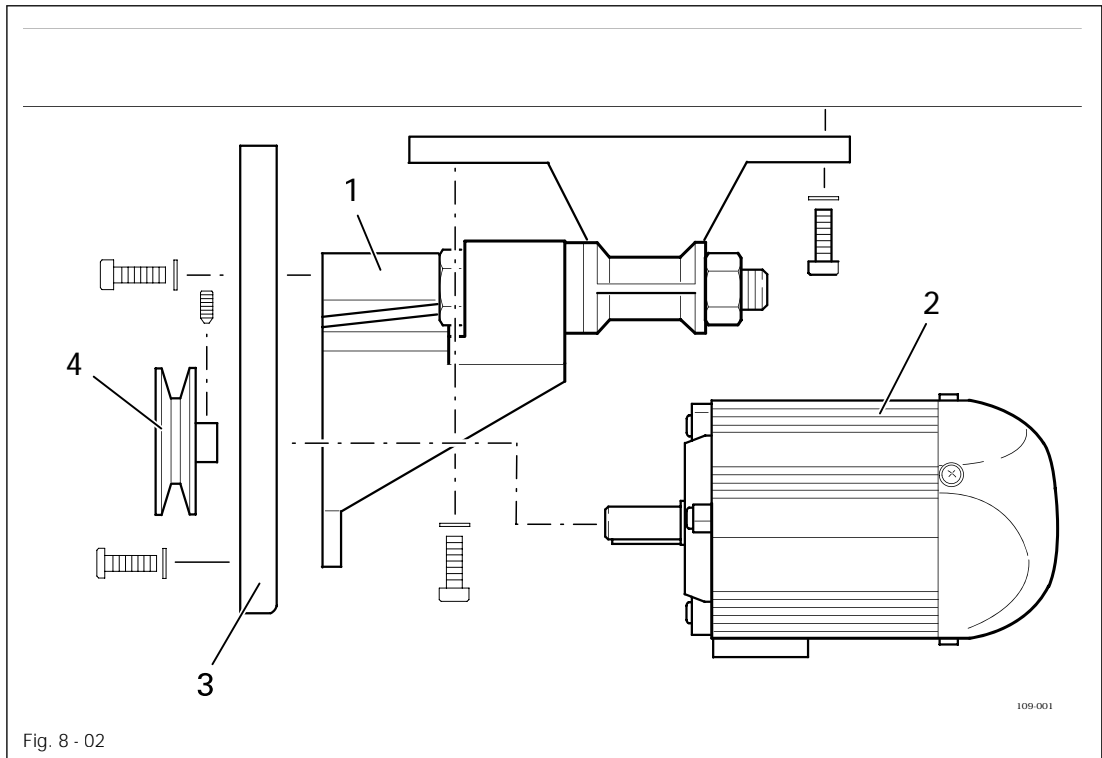

Fig. 8 - 01

- Loosen screws 1 and 2 and set the desired table-top height
- Tighten screws 1 well.
- Adjust the position of the pedal so that you can operate it comfortably and tighten screw 2.

## 8.01.02 Assembling the motor (only on machines with Quick-motor)



- Assemble motor mounting 1, motor 2, belt guard support 3 and belt pulley 4 as shown in Fig. 8-02.

## 8.01.03 Tightening the V-belt

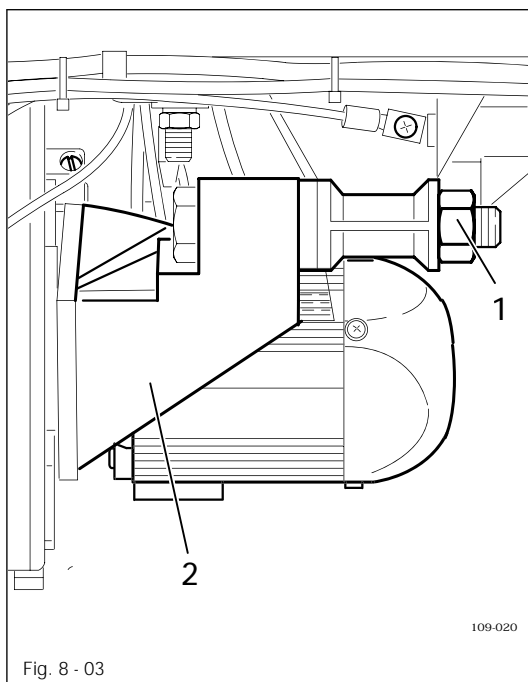

- Fit the V-belt.
- Loosen nut 1 and tighten the V-belt by turning motor mounting 2.
- Tighten nut 1.

## 8.01.04 Mounting the bottom V-belt guard

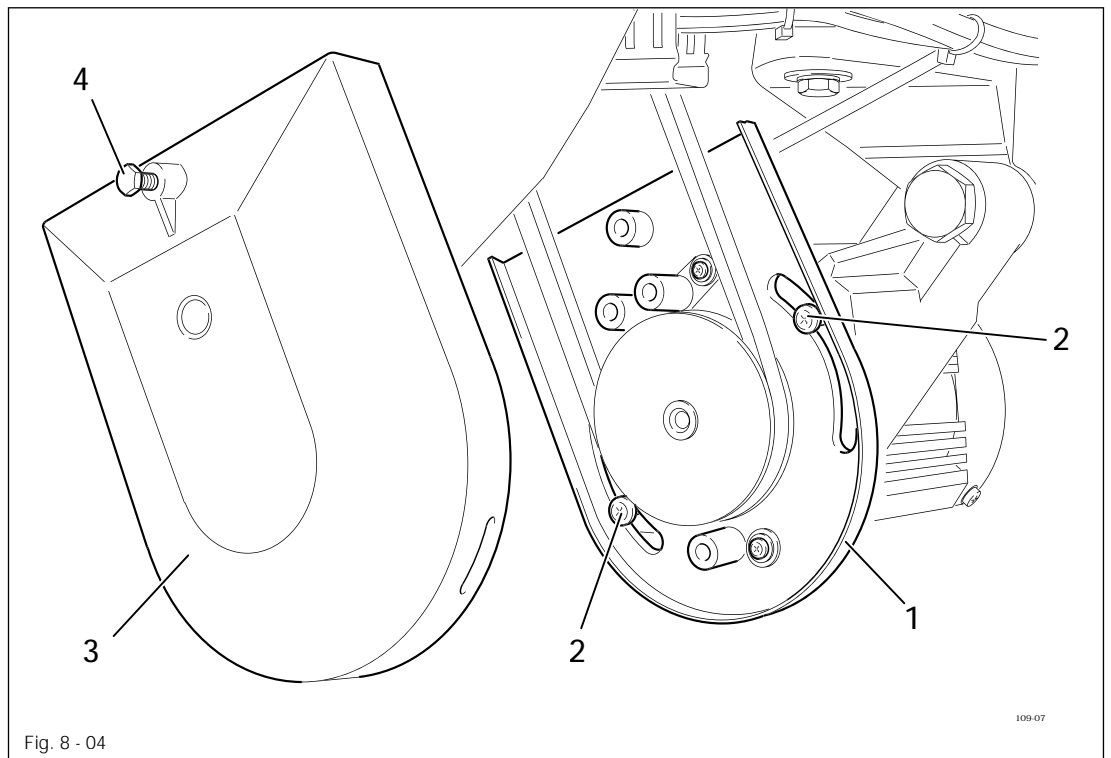

- Loosen screws 2 and adjust belt guard support 1 so that the motor pulley and V-belt run freely.
- Tighten screws 2.
- Fasten belt guard 3 with screw 4.



Fig. 8-04 shows a Quick-motor. If a different motor is used, follow the instructions of the Motor Instruction Manual.

## 8.01.05 Fitting the upper belt guard

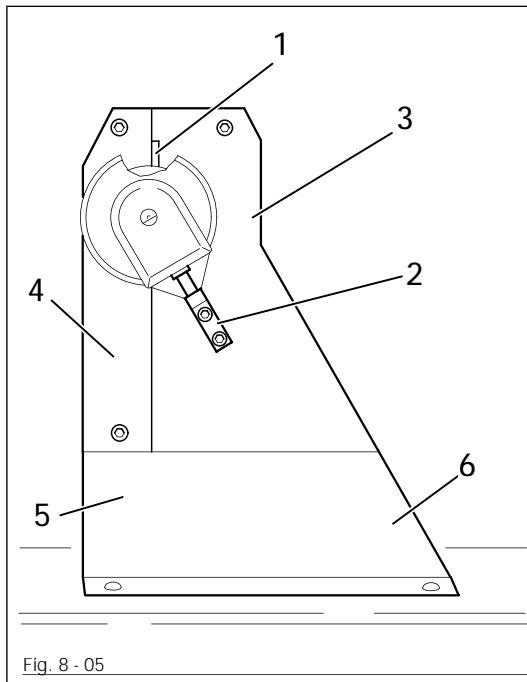

If a large balance wheel is used, the corner 1 of the belt guard 3 must be broken out.

- Screw stop piece 2 onto belt guard part 3.
- Screw on belt guard part 3 onto the housing.
- Screw on belt guard part 4 onto the housing.
- Secure belt guard parts 5 and 6 onto the table top.

## 8.01.06 Fitting the synchronizer

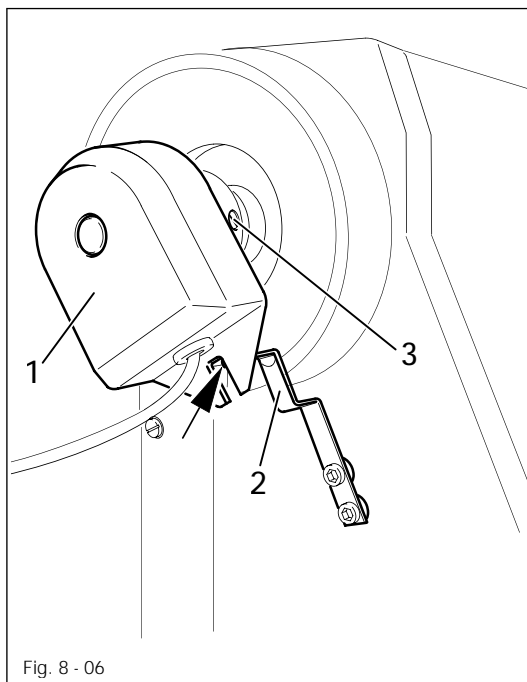

- Push synchronizer 1 onto the shaft so that stop 2 is standing in the slot on the synchronizer (see arrow)
- Tighten screws 3.
- Connect the synchronizer plug to the control box.
- Connect the synchronizer plug to the adapter (see Chapter 8.01.08 Connecting the plug connections and earth cables).

## 8.01.07 Fitting the reel stand

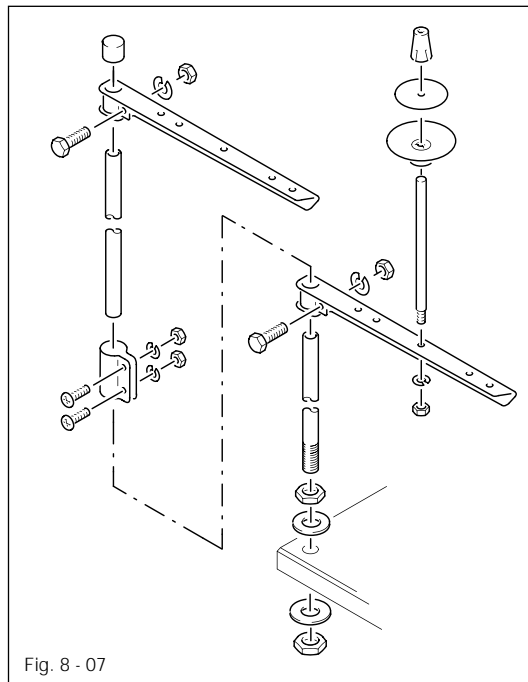

- Fit the reel stand as shown in Fig. 8 - 07.
- Afterwards insert the stand in the hole in the table top and secure it with nuts provided.



Table top mounting and circuit diagrams  
(see Chapter 11)

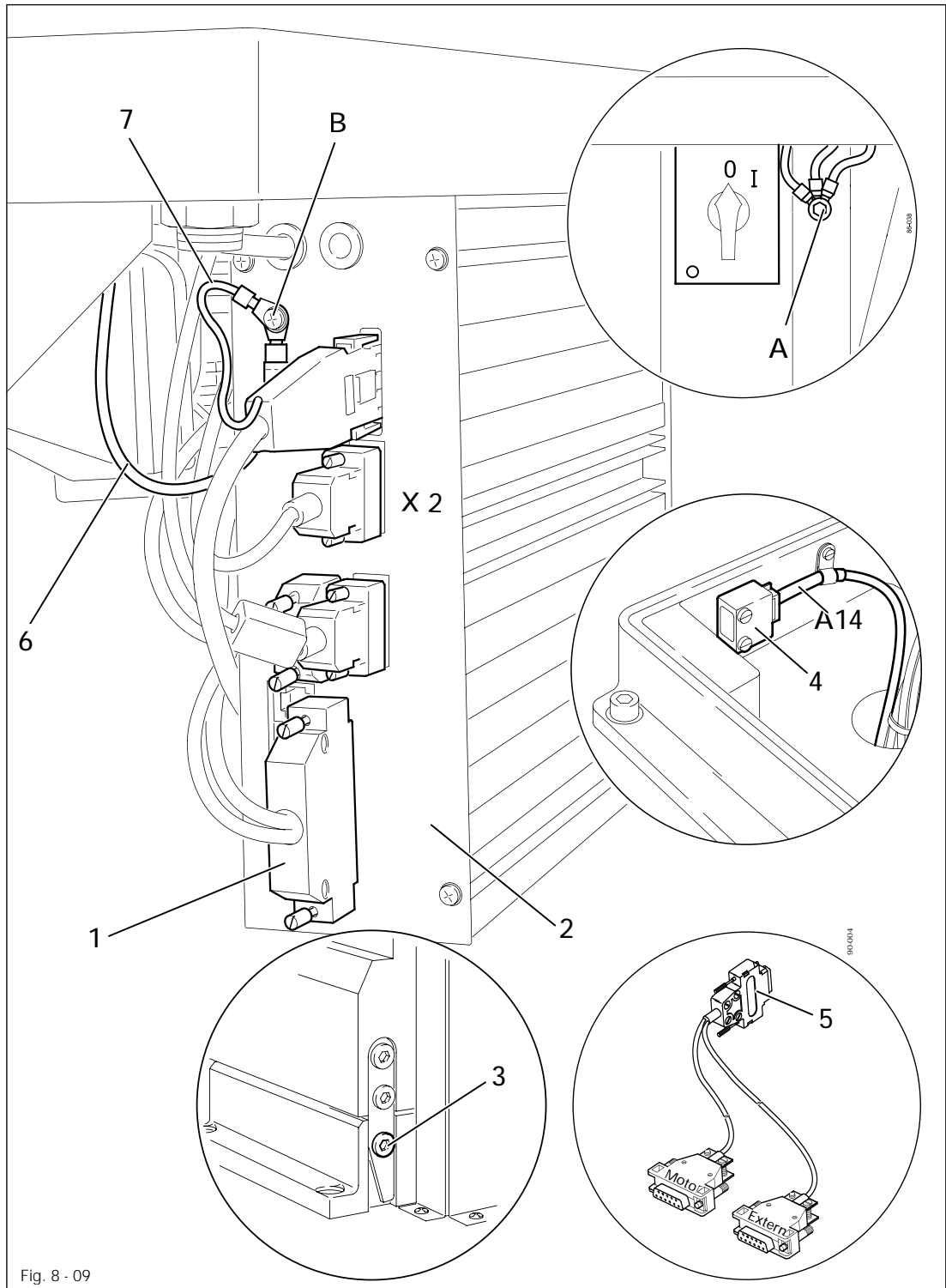

Fig. 8 - 09

- Plug adapter cable 1 into control box 2.
- Remove screw 3 and tilt the machine back.
- Plug the cable coming from the machine to adapter cable 1 as marked.
- Plug the cable A14 coming from adapter 1 to the sewing head recognition unit 4.



Use both hands to set the sewing head upright!

Danger of crushing between the sewing head and the table top!

- Insert plug 5 from the adapter cable to bush X 2.
- Connect the motor to the "motor" plug and the synchronizer to the "external" plug.
- Screw the earth cable from the sewing head and the main switch to earth point A.
- Connect earth point A to earth point B with earth cable 6.
- Screw the earth cable 7 from the motor to earth point B.

### 8.02 Commissioning

- Check the machine, particularly its electrical wiring and pneumatic tube connections, for any damage.
- Clean the machine thoroughly and oil it (see chapter 10 **Care and maintenance**).
- Have skilled personnel check if the machine can be operated with the available mains voltage. .



Do not operate the machine if there is any discrepancy.



Before commissioning the machine, have specialized personnel check whether the parameter 799 (machine class) is set at "2" and the parameter 800 (sewing direction) is set at "1". If necessary, have the adjustment carried out (see Chapter 8.04 **Basic position of the machine drive unit**).



The machine may only be connected to an earthed socket!

- Connect the machine to the compressed air supply. When it is connected, the gauge should show a pressure of approx. 6 bar. If necessary, have this reading correctly set (see Chapter 10.08, **Checking/adjusting the air pressure**).

### 8.03 Switching the machine on/off

- Switch the machine on (see Chapter 7.01, **On/off switch**).

### 8.04 Basic position of the machine drive unit

(only on machines with Quick-EcoDrive and control unit P40ED)

- Switch on the machine.
- Press the **TE/speed** key twice to select the input mode.
- Select parameter "798" by pressing the corresponding +/- key, and select service level C, see Chapter **Selecting the user level** in the instruction manual for the control panel.
- By pressing the corresponding +/- key select the parameter "799" (Selecting the machine class).
- Check whether value "2" is set, and correct it if necessary.



If the parameter has to be altered, operate the **TE/Speed** key and then switch off the machine and switch it on again. Then select service level C again as described above.

- By pressing the corresponding +/- key, select parameter "800" (selecting the sewing direction).
- By pressing the corresponding +/- key, select the value for the parameter at "1".
- By pressing the corresponding +/- key, select parameter "700".
- Sew a stitch by operating the pedal.
- Turn the balance wheel in the sewing direction until the descending needle is level with the top edge of the needle plate.
- Then check the parameter values listed in the parameter list (see Chapter **10.09 Parameter Settings**) and adjust them if necessary.
- Conclude the adjustment of the sewing motor by pressing the **TE/Speed** key.



9

## Setting up



All instructions and regulations in this instruction manual must be observed. Special attention must be given to all safety regulations!



All setting-up work must only be done by personnel with the necessary training. For all setting-up work the machine must be isolated from its power supply by turning off the on/off switch or removing the machine plug from the electric power socket!

9.01

## Inserting the needle

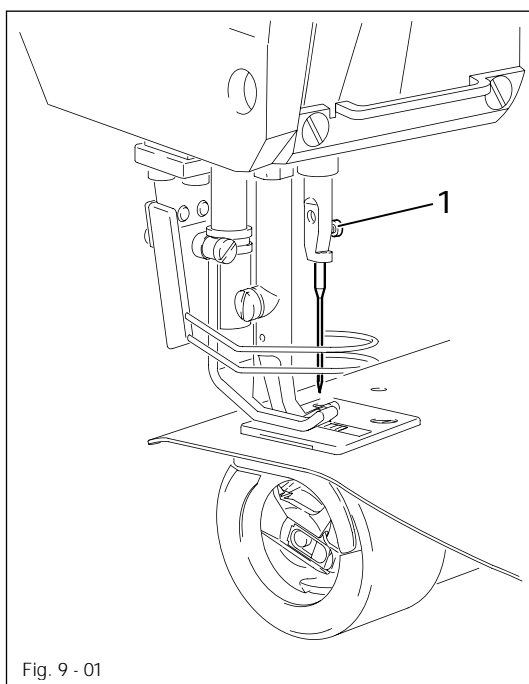

Switch the machine off!  
Danger due to unintentional starting of the machine!



Only use needles from the system intended for the machine, see Chapter 3 **Specifications**.

- Raise needle bar.
- Loosen screw 1 and insert needle until you feel it stop.
- The long needle groove must be aligned in the direction of the machine head.
- Tighten screw 1.

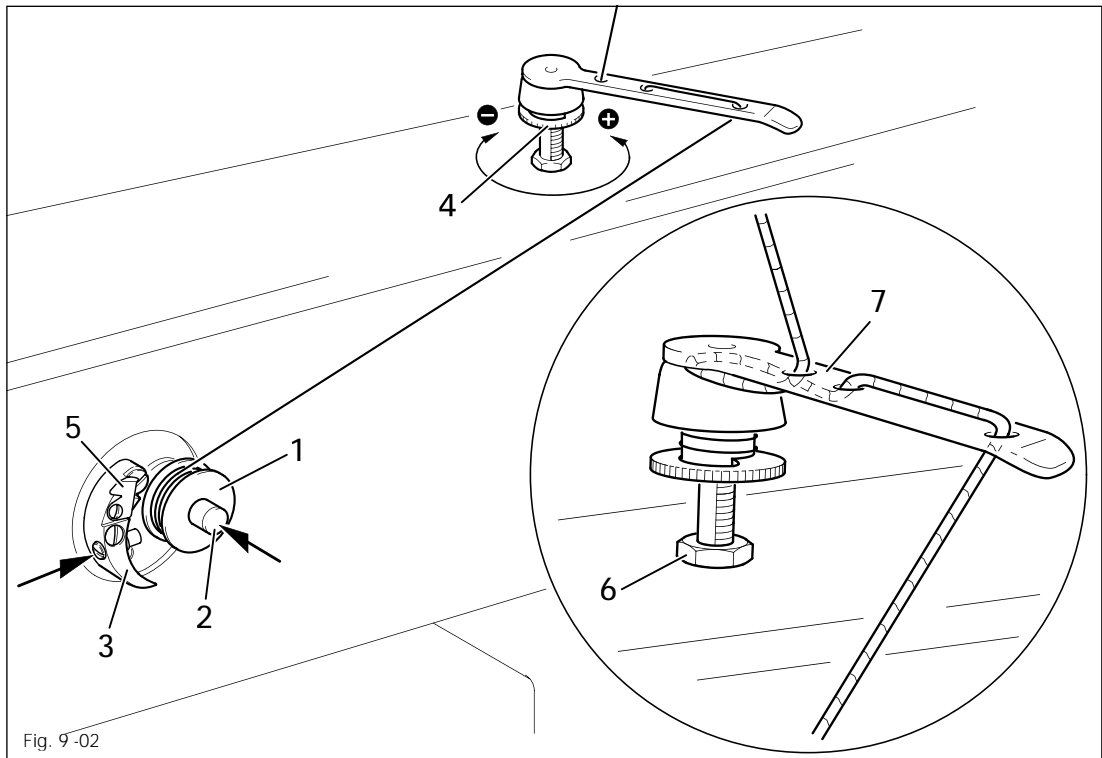

- Place an empty bobbin 1 onto bobbin shaft 2.
- Thread the bobbin in accordance with Fig. 9-02 and wind it anti-clockwise around bobbin 1 a few times.
- Switch on the bobbin winder while at the same time pressing bobbin winder spindle 2 and lever 3.



The bobbin fills up during sewing.

- The tension of the thread on bobbin 1 can be adjusted with knurled screw 4.
- The bobbin winder stops automatically when bobbin 1 is full.
- Remove the filled bobbin 1 and cut the thread on knife 5.



If the thread is wound unevenly, loosen nut 6 and turn thread guide 7 accordingly. Retighten nut 6 after the adjustment.

## 9.03 Removing / Inserting the bobbin case

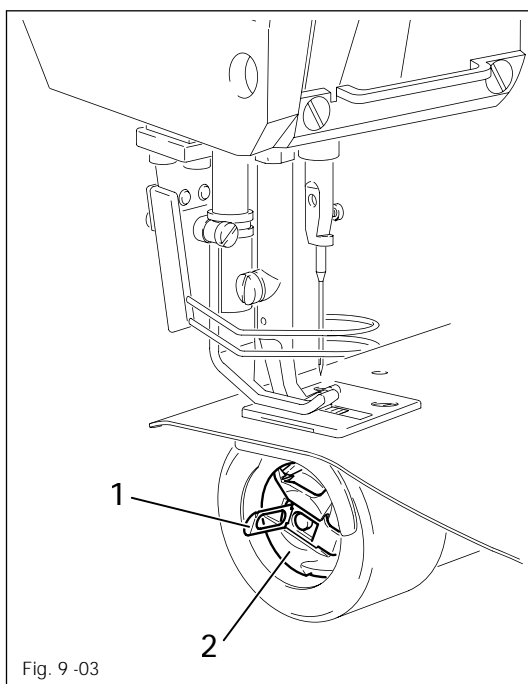

Switch the machine off!  
 Danger due to unintentional starting of the machine!

### Removing the bobbin case:

- Lift latch 1 and take out bobbin case 2.

### Inserting the bobbin case:

- Insert full bobbin case 2 so that you feel it snap in place.

## 9.04 Threading the bobbin thread and regulating the bobbin thread tension

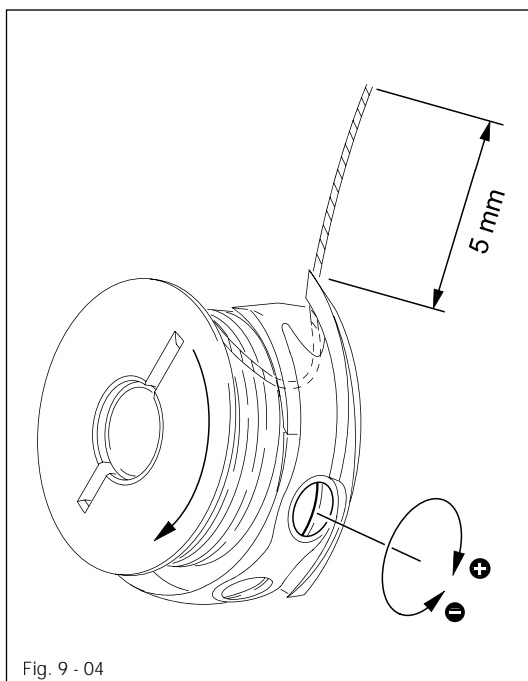

- Thread the bobbin as shown in Fig. 9-04.
- When the thread is pulled, the bobbin must rotate as shown by the arrow.
- Regulate the bobbin thread tension on screw 1.

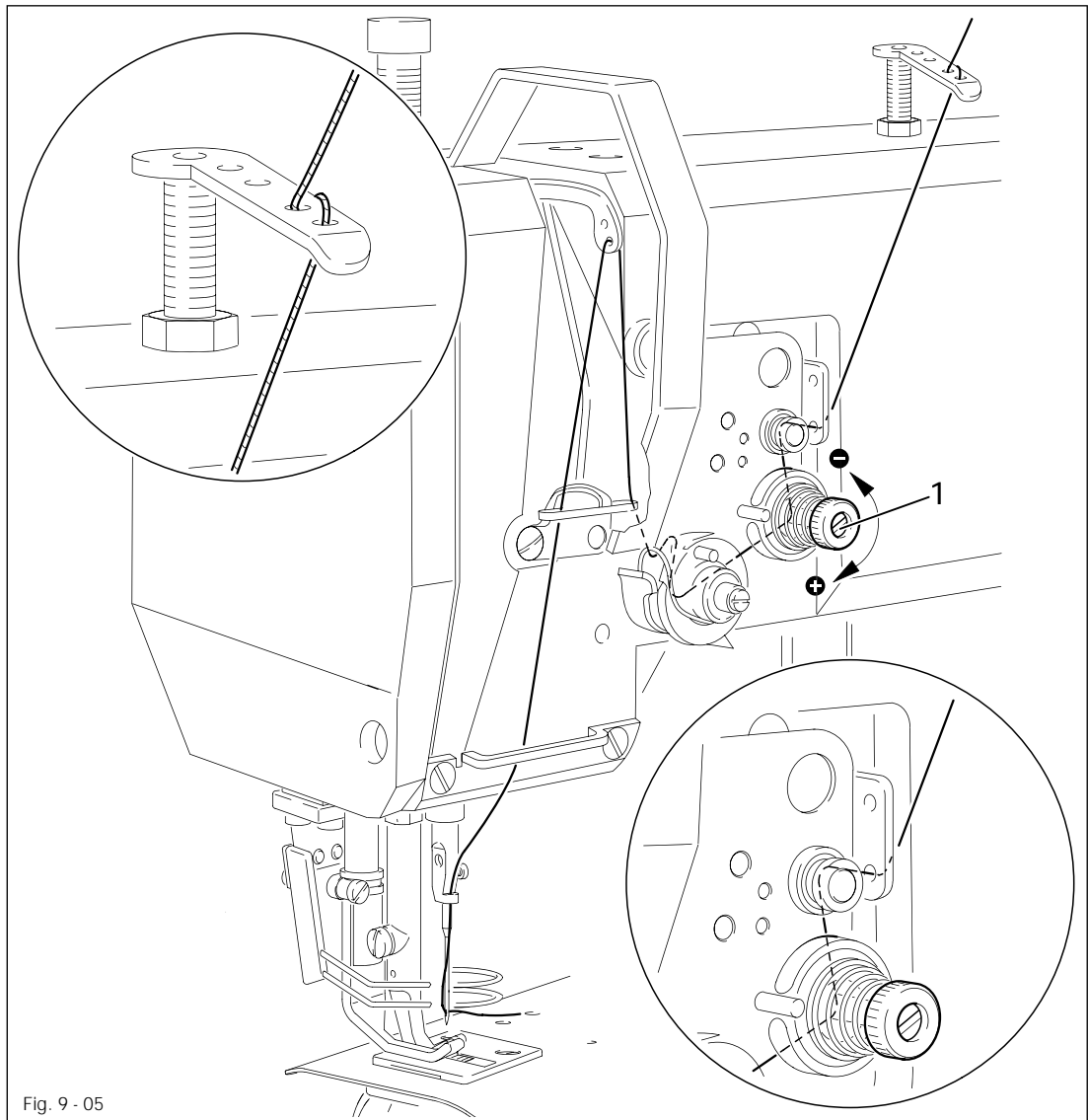

Fig. 9 - 05



Switch the machine off!

Danger due to unintentional starting of the machine!

- Thread needle thread as shown in Fig. 9-05.
- Be sure to thread the needle from the left.
- Regulate the needle thread tension by turning knurled screw 1.

9.06      **Adjusting the stitch counter for the bobbin thread control**

(only on machines with Quick Motor and P40 (ED) control unit)

Please see the description in the separate control panel instruction manual.  
werden.

## 10 Care and maintenance

### 10.01 Care and maintenance intervals

|  |  |
|--|--|
| Cleaning .....                                 | daily, in continuous operation several times |
| General oiling .....                           | twice a week                                 |
| Oil the hook.....                              | daily, before putting into operation         |
| Oil needle-head parts .....                    | twice a week                                 |
| Lubricate the bevel gears.....                 | once a year                                  |
| Lubricate the top-feed drive eccentric .....   | Annually                                     |
| Check/adjust air pressure.....                 | daily, before putting into operation         |
| Check water bowl of air filter/regulator ..... | daily, before putting into operation         |



The maintenance intervals in the table refer to the average machine running time in single-shift operation. If the machine running time is longer than this, it is advisable to shorten these intervals.

### 10.02 Cleaning

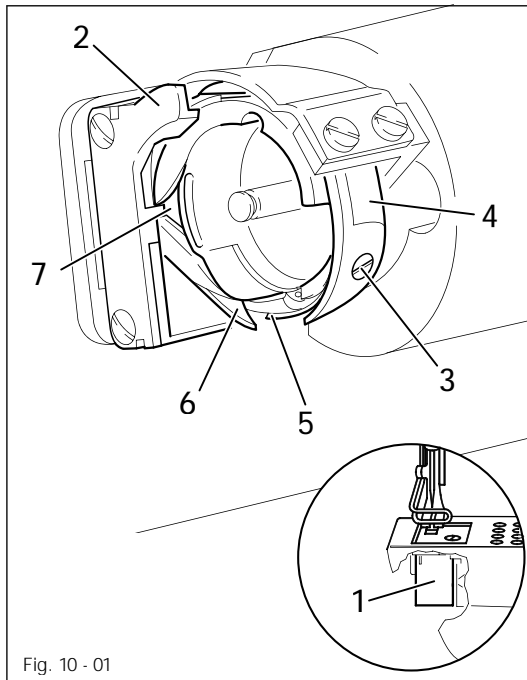

Fig. 10 - 01



Switch off the machine!  
Danger of injury due to unintentional starting of the machine!

#### Cleaning the hook area

- Clean hook area with a brush daily, in continuous operation several times daily.

#### Cleaning the hook

- Open cylinder-bed cap 1.
- Set needle bar at its highest position.
- Remove top of bobbin case together with bobbin
- Unscrew and remove bobbin case position stop 2.
- Remove screw 3 and take off hook gib 4.
- Turn balance wheel until point 5 is aligned with point 6.

- Take out bobbin case and clean hook race with petroleum spirit.
- When inserting the bobbin case, make sure that the lug on the rear side of bobbin case position stop 2 enters into groove 7.
- Screw on hook gib 4.
- Insert bobbin case and close cylinder-bed cap 1.



Do not run the machine without cylinder-bed cap 1!  
Danger of injury by rotating hook!

10.03 General oiling

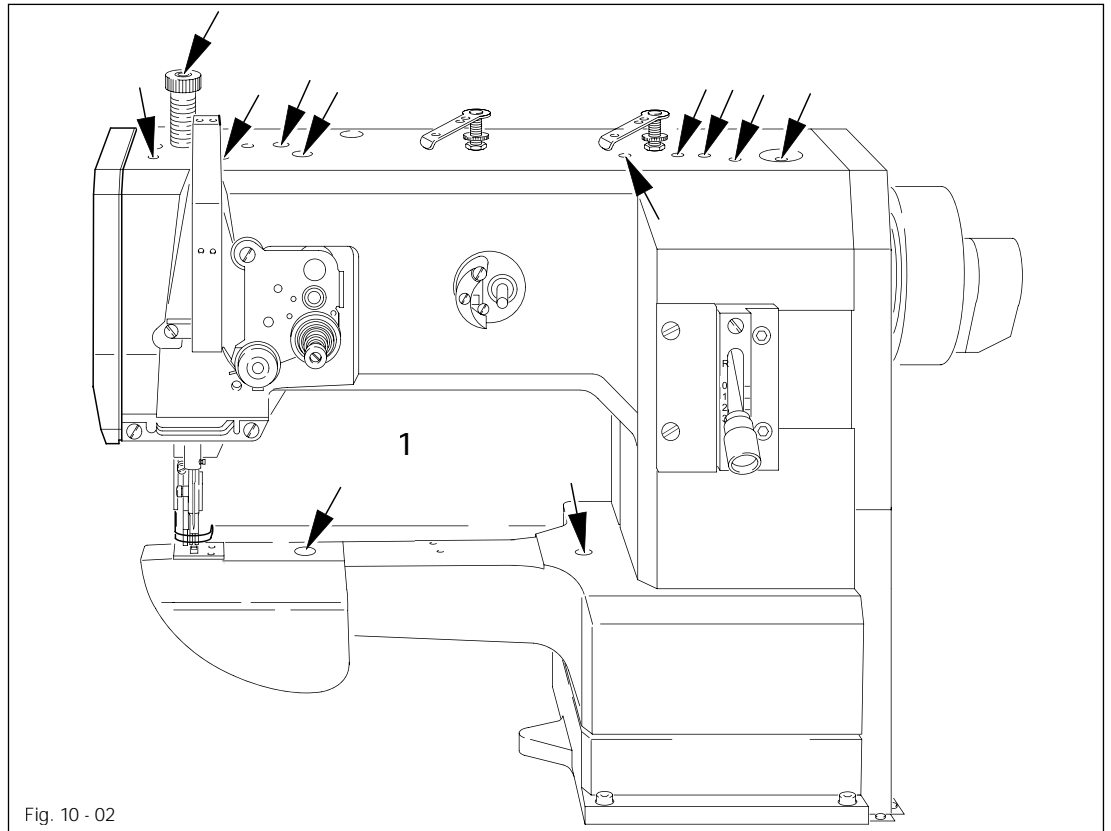

Fig. 10 - 02



Switch off the machine!  
 Danger of injury due to unintentional starting of the machine!

- Oil all bearing parts above the table top twice a week ( see arrows ).

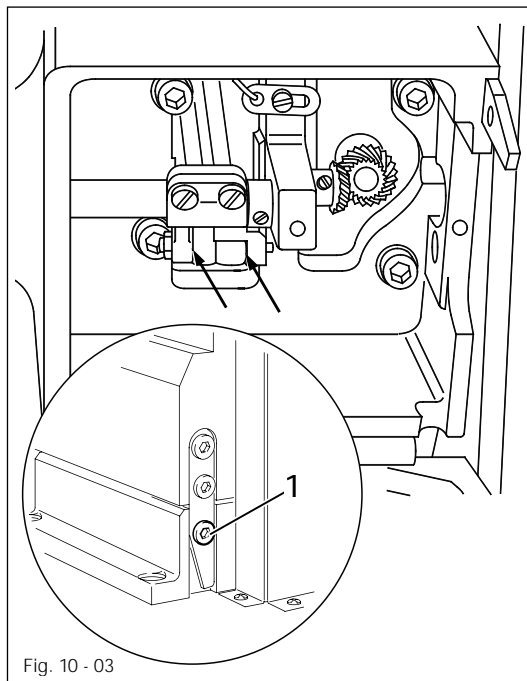

Fig. 10 - 03

- Remove screw 1 and tilt machine backwards.
- Apply oil at all bearing points beneath the table (see arrows) twice a week.



Set the machine upright with both hands!  
 Danger of crushing between sewing head and table!

- Tighten screw 1 again.



Only use oil with a viscosity of 22.0 mm<sup>2</sup>/s at 40° C and a density of 0.865 g/cm<sup>3</sup> at 15°C!

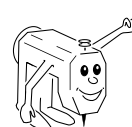

We recommend PFAFF sewing-machine oil, part No. 280-1-120 144.

## 10.04 Oiling the sewing hook

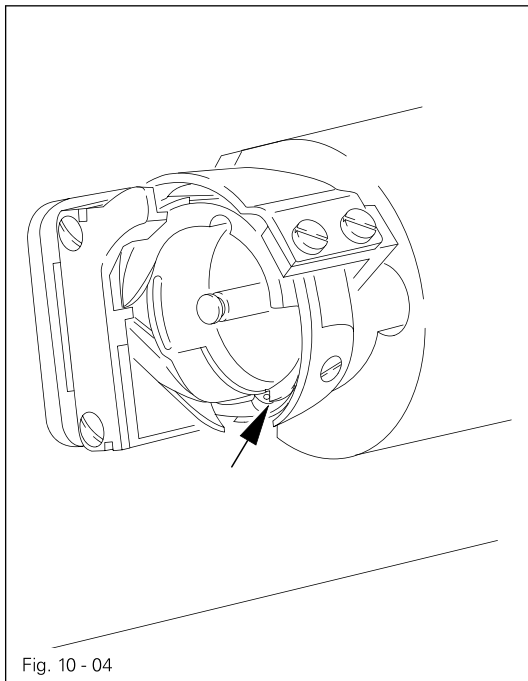

Switch off the machine!  
Danger of injury due to unintentional starting of the machine!

- Remove the bobbin case.
- Apply 1 - 2 drops of oil to the hook race daily (see arrow).
- Replace the bobbin case.



Only use oil with a viscosity of  $22.0 \text{ mm}^2/\text{s}$  at  $40^\circ \text{ C}$  and a density of  $0.865 \text{ g/cm}^3$  at  $15^\circ \text{ C}$ !

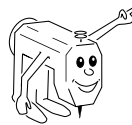

We recommend PFAFF sewing-machine oil, part No. 280-1-120 144.

## 10.05 Oiling the needle-head parts

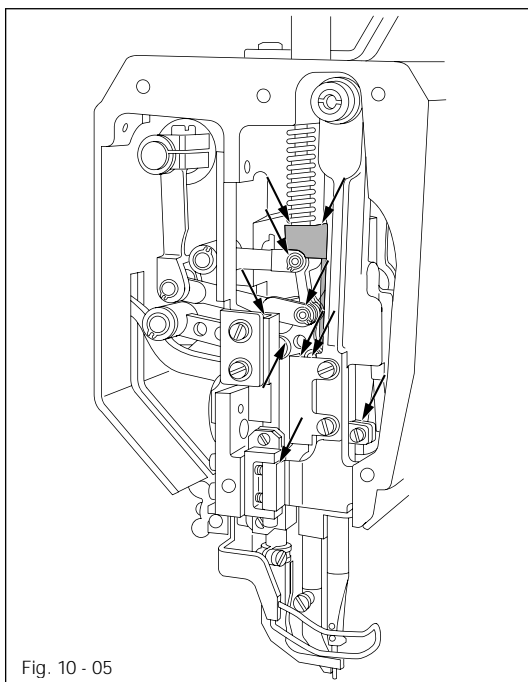

Switch off the machine!  
Danger of injury due to unintentional starting of the machine!

- Remove the faceplate.
- Oil all moving parts and bearing points (see arrows) twice a week.
- Refit the faceplate.



Only use oil with a viscosity of  $22.0 \text{ mm}^2/\text{s}$  at  $40^\circ \text{ C}$  and a density of  $0.865 \text{ g/cm}^3$  at  $15^\circ \text{ C}$ !

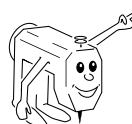

We recommend PFAFF sewing-machine oil, part No. 280-1-120 144.



10.06 Lubricating the bevel gears

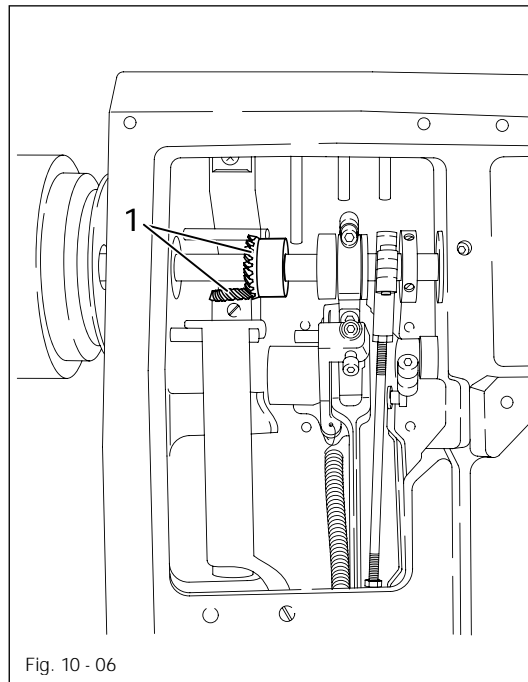

Fig. 10 - 06

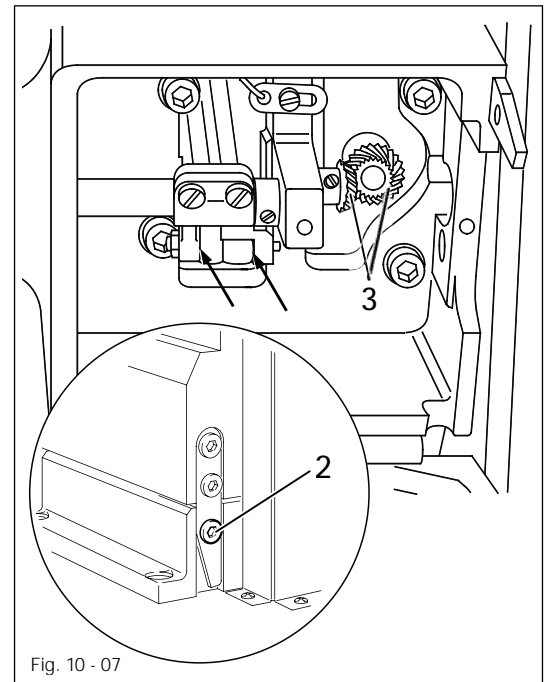

Fig. 10 - 07



Switch off the machine!  
 Danger of injury due to unintentional starting of the machine!



All bevel gears must be supplied with new grease once a year.

**Top bevel gears**

- Unscrew the cover on the rear side of the machine.
- Apply fresh grease to the top bevel gears 1.
- Screw the cover to the rear side of the machine again.

**Bottom bevel gears**

- Remove screw 2 and tilt the machine back.
- Apply fresh grease to the bottom bevel gears 3.



Use both hands to set the sewing head upright!  
 Danger of crushing between the sewing head and the table top!

- Retighten screw 2.

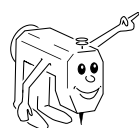

We recommend PFAFF sodium grease with a dripping point of approx. 150C,  
 Order No. 280-1-120 243.

### 10.07 Lubricating the top-feed drive excentric

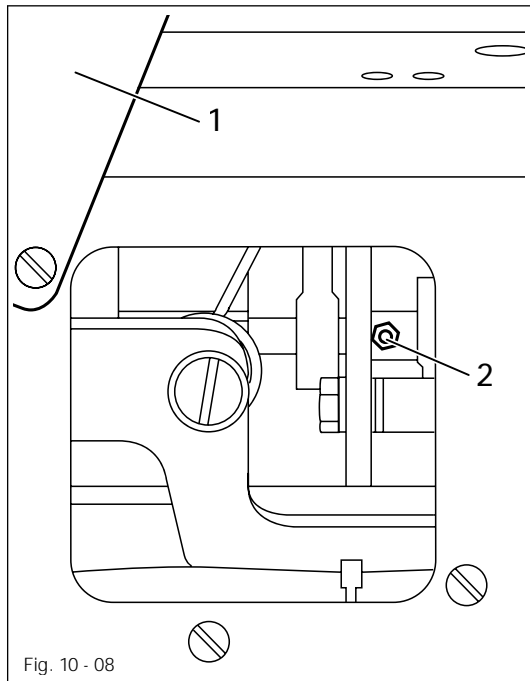

Switch off the machine!  
Danger of injury due to unintentional starting of the machine!

- Open cover 1 on the back of the machine.
- Grease nipple 2 at least once a year (use grease gun).
- Screw cover 1 back on.



Only use lithium base grease with a dripping point of 185°C and a worked penetration of 22-25 mm at 25°C.

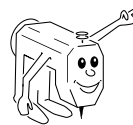

We recommend Pfaff sewingmachine grease Part no. 280-1-120 247

### 10.08 Checking/regulating the air pressure

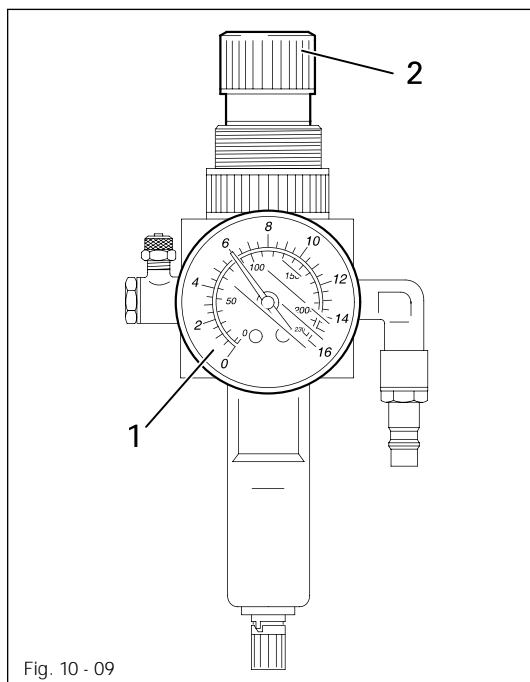

- Check the air pressure on gauge 1 every time before operation.
- Gauge 1 must show a pressure of 6 bar.
- Regulate this pressure if required.
- To do so, pull knob 2 up and turn it accordingly.

10.09 Emptying/cleaning the water bowl of the air filter/regulator

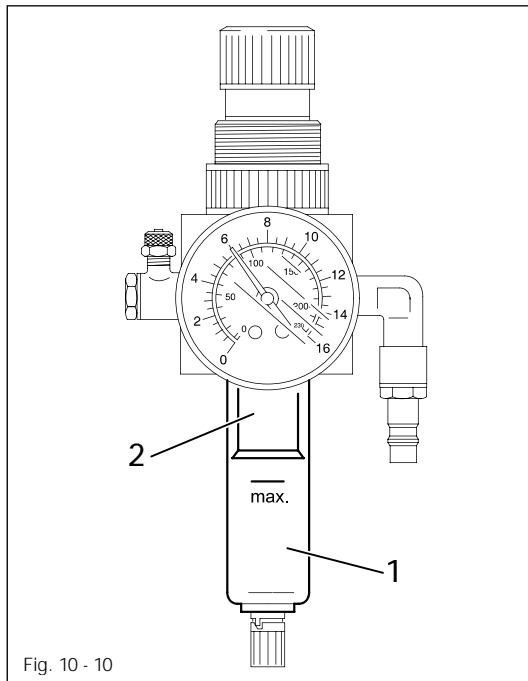

Fig. 10 - 10



Switch off the machine.  
Disconnect the air hose at the  
air filter/regulating unit.

**Emptying the water bowl**

- Water bowl 1 empties itself automatically when the air hose is disconnected from the air filter/regulator.

**Cleaning the filter**

- Unscrew water bowl 1 and take out filter 2.
- Clean the filter with compressed air or with isopropyl-alcohol, part number 95-665 735-91.
- Screw in filter 2 and screw on water bowl 1.

## 10.10 Parameter settings

(only on machines with Quick-EcoDrive and control unit P40ED)

- The selection of the user level and the alteration of parameters is described in the separate instruction manual for the drive unit.

### 10.10.01 Parameter list

| Group | Parameter              | Description   | User level | Setting range | Set value |
|-------|------------------------|---|------------|---------------|-----------|
| 1     | 105                    | Speed for start backtack  | B, C       | 300 - 2000    | 800       |
|       | 110                    | Speed for end backtack  | B, C       | 300 - 2000    | 1000      |
| 6     | 607                    | Speed max.  | B, C       | 300 - 2000    | ▲         |
|       | 609                    | Cutting speed 1   | B, C       | 60 - 300      | 180       |
| 7     | 700                    | Needle position 0 (needle reference position)                         | B, C       | 0 - 255       | *         |
|       | 702                    | Needle position 1 (needle lowered)                                    | B, C       | 0 - 255       | 85        |
|       | 703                    | Needle position 2 (take-up lever raised)                              | B, C       | 0 - 255       | 230       |
|       | 705                    | Needle position 5 (end cutting signal 1)                              | B, C       | 0 - 255       | 100       |
|       | 706                    | Needle position 5 (start cutting signal 2)                            | B, C       | 0 - 255       | 85        |
|       | 707                    | Needle position 9 (start thread tension release/start thread catcher) | B, C       | 0 - 255       | 195       |
|       | 722                    | Acceleration ramp   | B, C       | 0 - 255       | 50        |
|       | 723                    | Brake ramp  | B, C       | 0 - 255       | 40        |
|       | 734                    | Tact output A2 (thread trimming)                                      | B, C       | 001 - 009     | 0         |
|       | 760                    | Multiplier for the fixed value (200) stitch count                     | A,B,<br>C  | 0 - 250       | 5         |
| 799   | Selected machine class | C   | 1 - 4      | 2             |           |
| 8     | 800                    | Rotating direction of the motor                                       | C          | 0 - 1         | 1         |
|       | 884                    | Proportional sensitivity of the speed control unit                    | B,C        | 03 - 24       | 10        |
|       | 897                    | Variant mini-motor, 1 = long, 2 = short                               | C          | 0 - 1         | 0         |
| 9     | 900                    | Additional P- sensitivity of the speed control unit                   | B,C        | 1 - 24        | 9         |

▲ See Chapter 3 Specifications

\* Adjustment see Chapter 8.05 Basic position of the machine drive unit.



Further parameters and the description for an internet update of the machine software and reset /cold start of the machine can be found in the instruction manual for the control panel.

## 11.01 Table top cutout

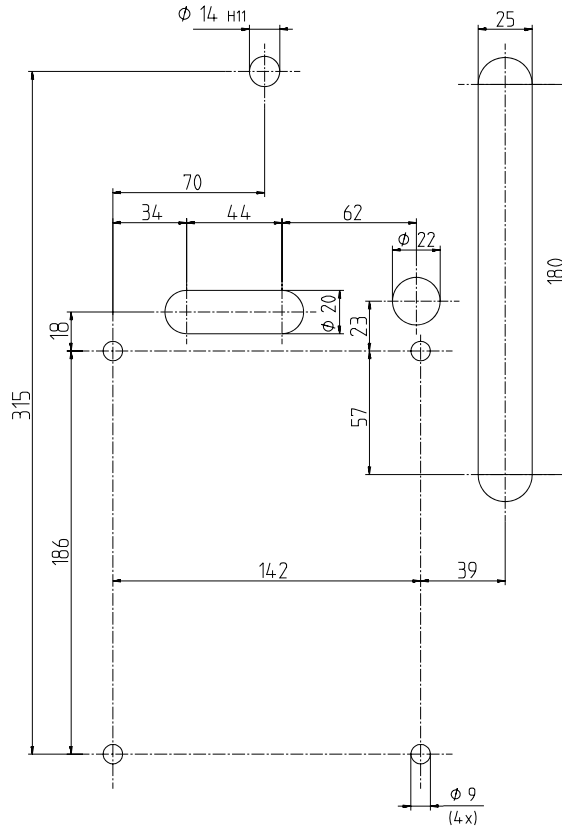

## 11.02 Mounting the table top

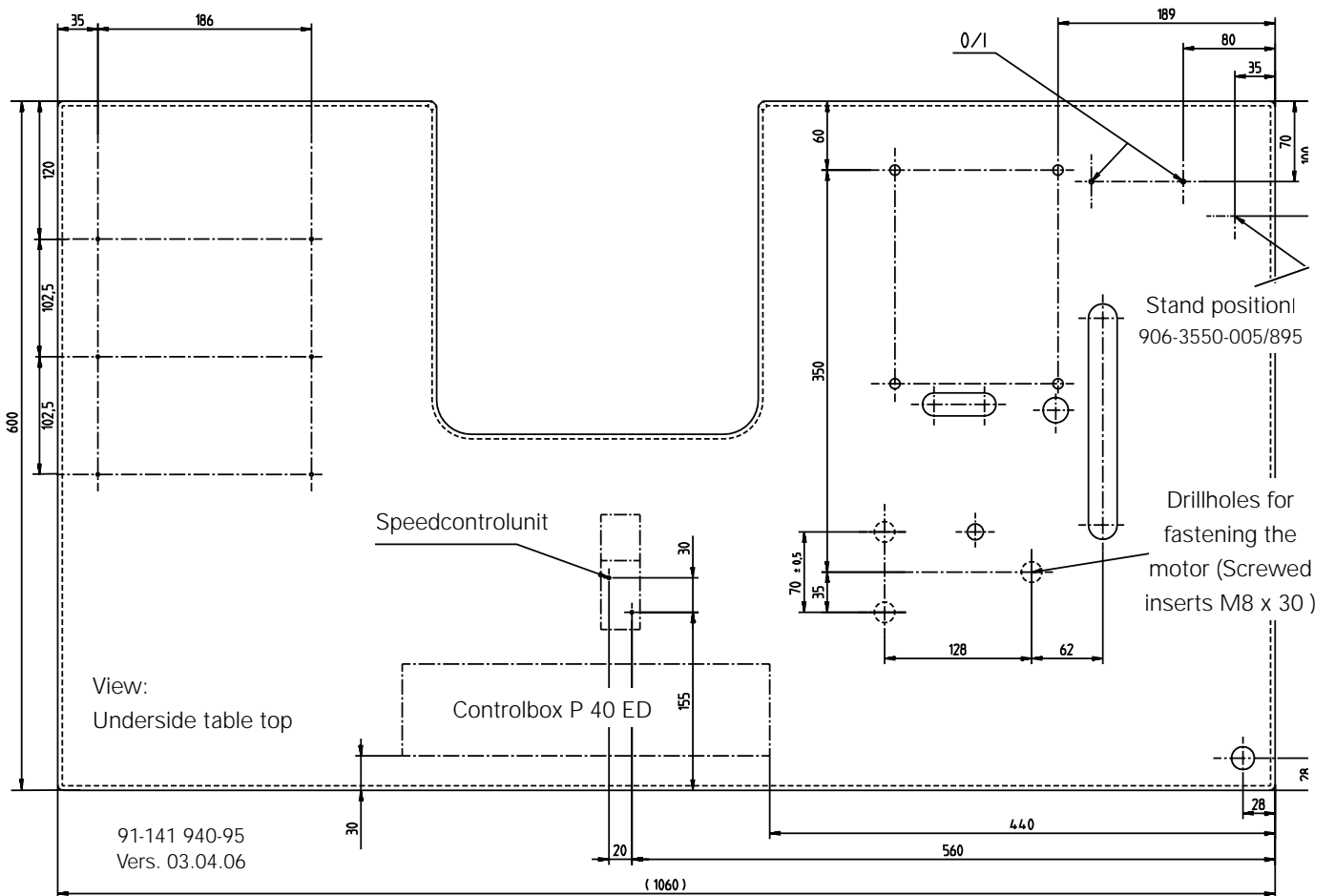

## 11.03 Circuit diagrams

### Reference list for the Circuit diagrams

|      |  |
|------|--|
| A1   | Control unit Quick P40 ED                |
| A2   | Control panel BDF S2                     |
| A14  | Sewing head recognition system (OTE)     |
| H1   | Sewing lamp (optional)                   |
| H10  | LED stitch counter                       |
| M1   | Sewing motor                             |
| Q1   | Main switch                              |
| S1   | Manual backtacking key                   |
| S1.1 | Pedal speed control unit                 |
| S2   | Needle position change key               |
| S3   | Single stitch key                        |
| S6   | Start inhibitor (E6 stop)                |
| X0   | PC-interface (RS 232)                    |
| X1   | Motor                                    |
| X2   | Incremental transducer                   |
| X2.1 | Incremental transmitter adapter          |
| X2.2 | Synchronizer adapter                     |
| X2.3 | Y5-911/.. backtacking device             |
| X3   | Speed control unit                       |
| X3.1 | Y2-900/.. thread trimmer (FS )           |
| X4   | A2 control panel plug BDF S2             |
| X4.1 | Y4 -910/.. automatic foot lift           |
| X5   | Out-/input                               |
| X6   | Bobbin thread monitor (optional)         |
| X6.1 | Y8 Thread tension release                |
| X7   | Photoelectric barrier (optional)         |
| X22  | Y2 -900/.. thread trimmer (FS )          |
| X24  | Y4 -910/.. automatic foot lift           |
| X25  | Y5 -911/.. backtacking device            |
| X28  | Y8 Thread tension release                |
| X40  | S1-3 Control panel                       |
| X50  | A14 Sewing head recognition system (OTE) |
| Y2   | -900/.. thread trimmer                   |
| Y4   | -910/.. automatic foot lift              |
| Y5   | -911/.. backtacking device               |
| Y8   | Thread tension release                   |

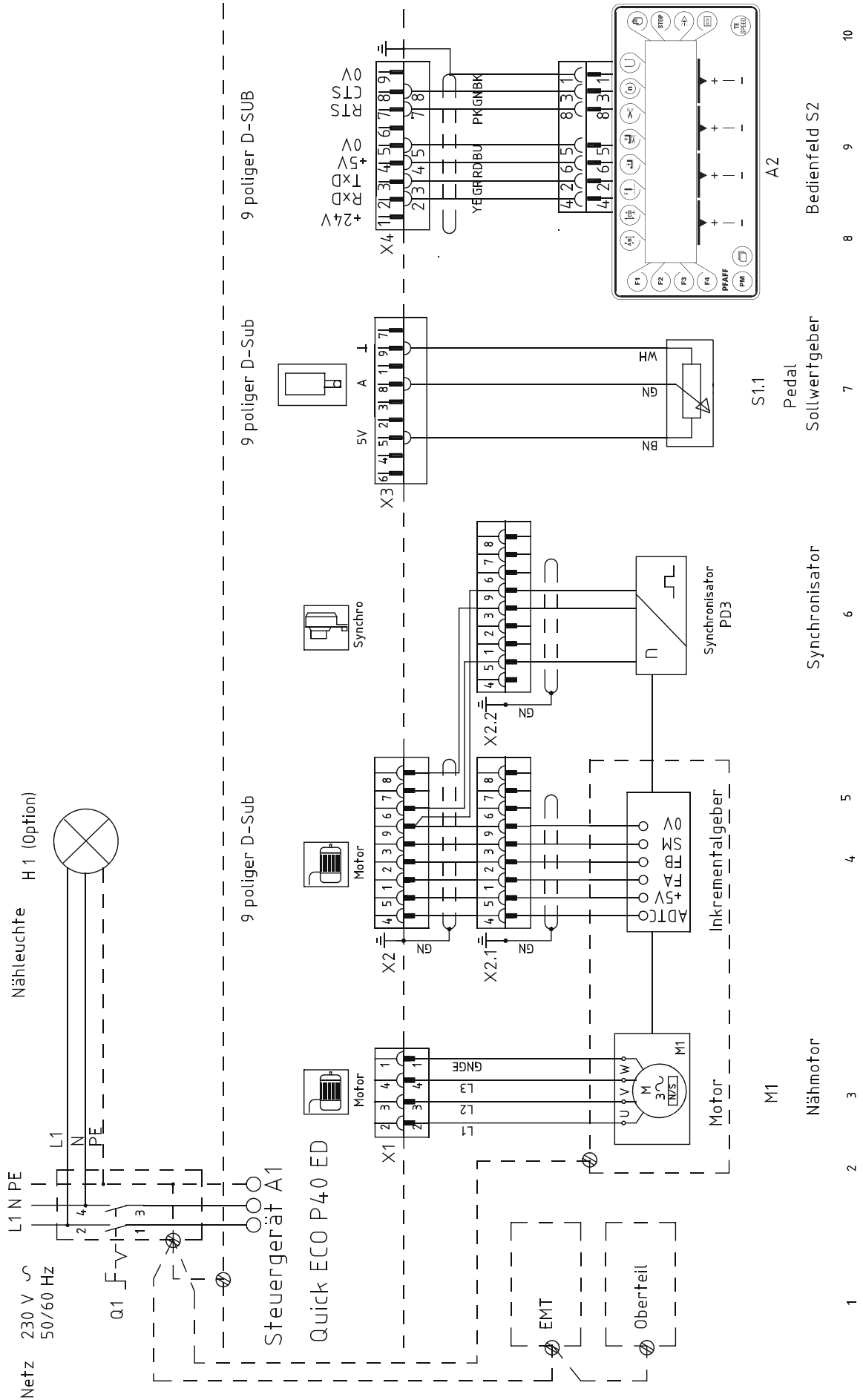

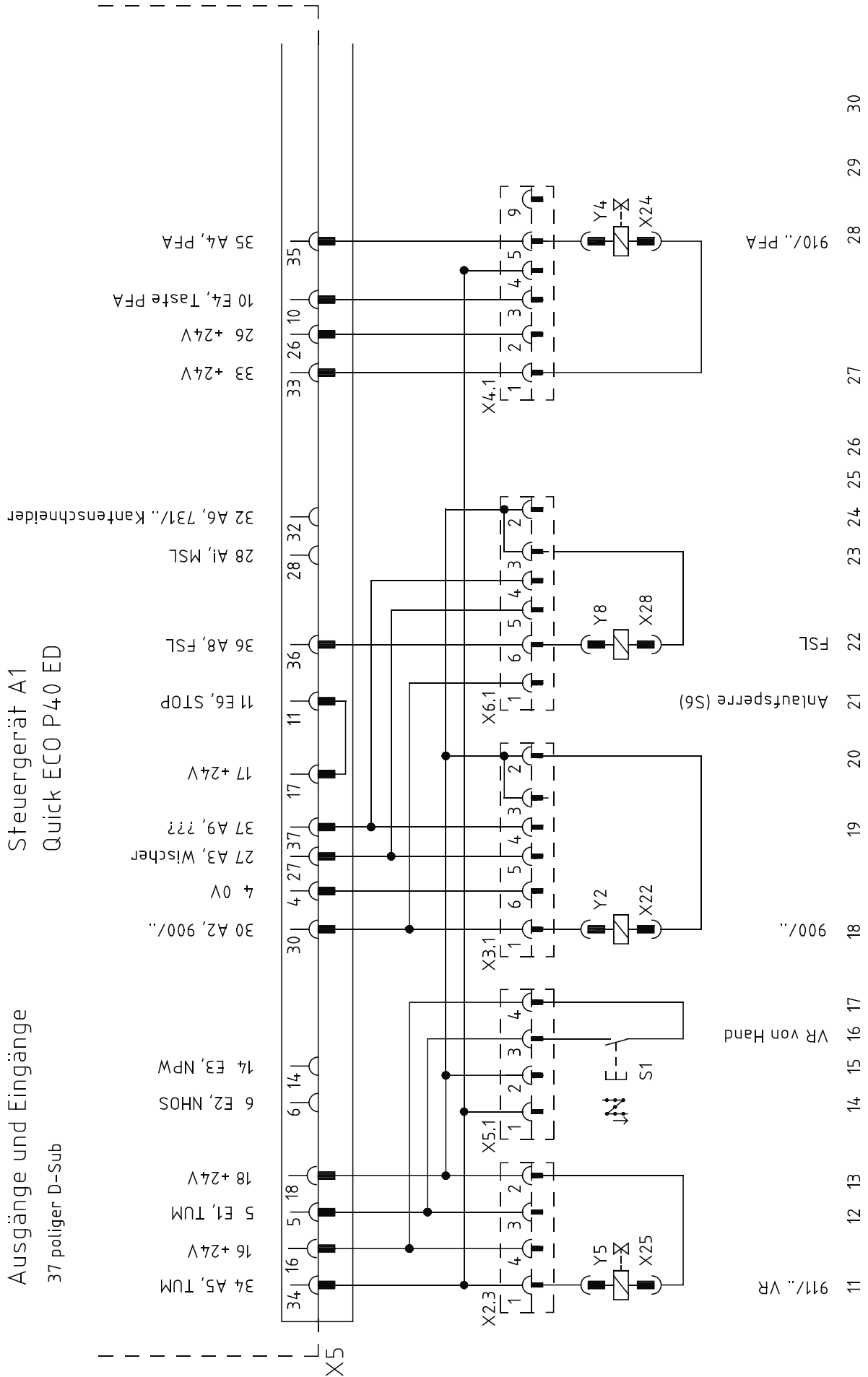



Steuergerät A1 Quick P40 ED

Sonderfunktionen

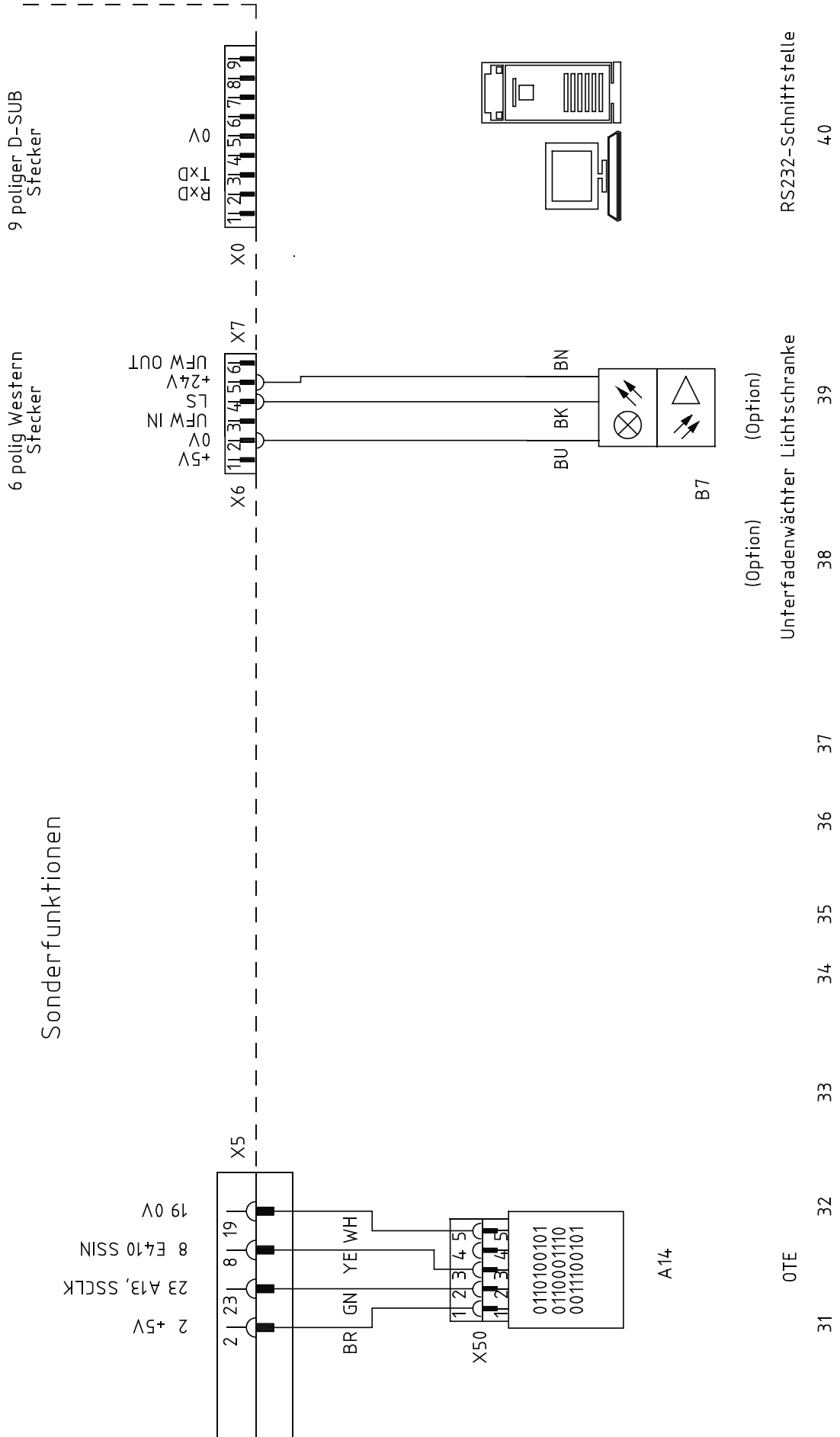

## 12

## Wearing parts

This is a list of the most important wearing parts.

A detailed parts list for the complete machine is included with the accessories.

In case of loss, the parts list can be downloaded from the internet address [www.pfaff-industrial.com/pfaff/de/service/downloads](http://www.pfaff-industrial.com/pfaff/de/service/downloads) As an alternative to the internet download the parts lists can also be ordered in book form under part no. 296-12-18 641

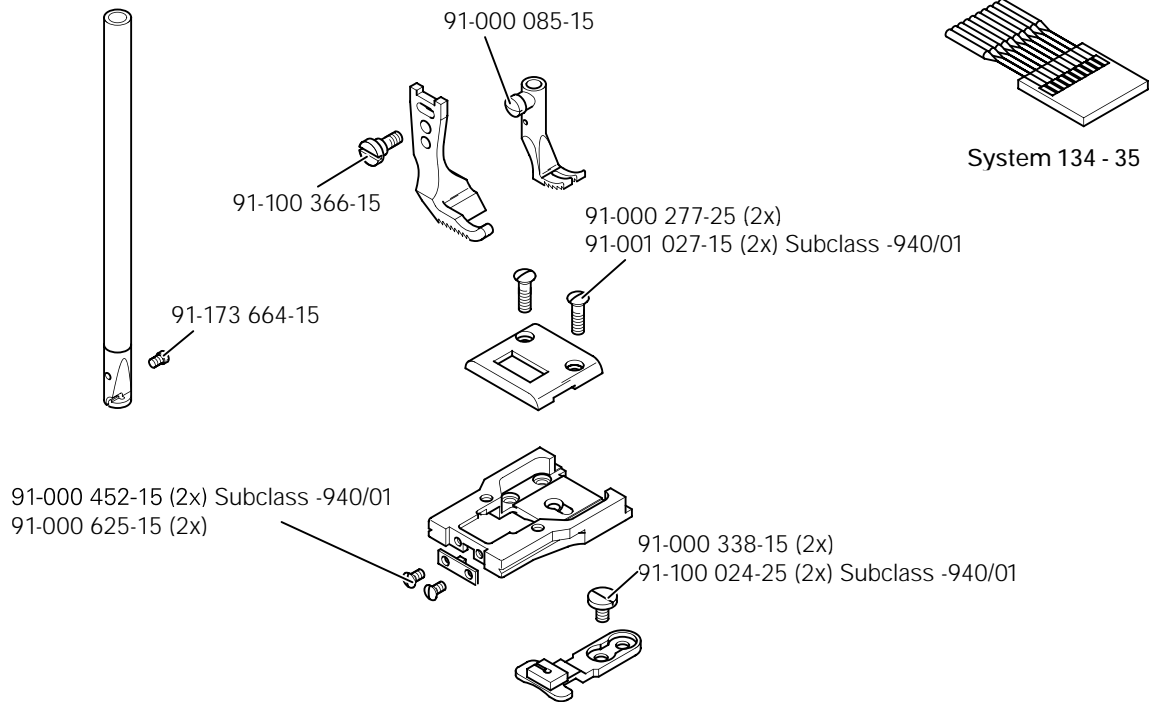

### PFAFF 335

91-060 461-91

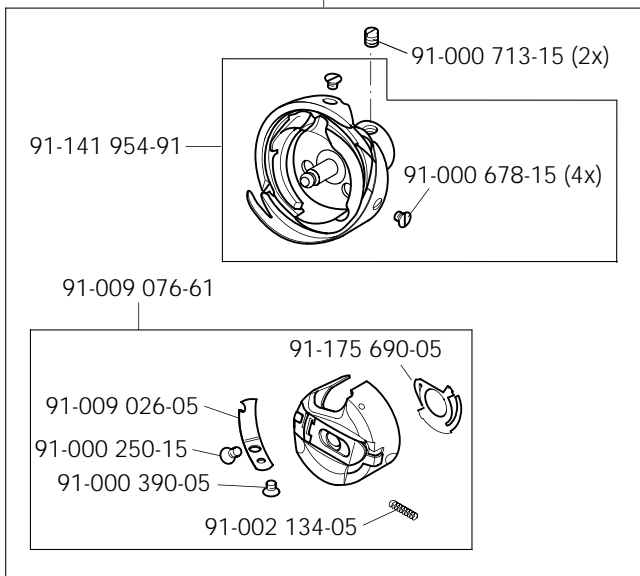

### PFAFF 335-G

91-060 581-91

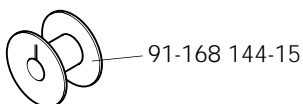
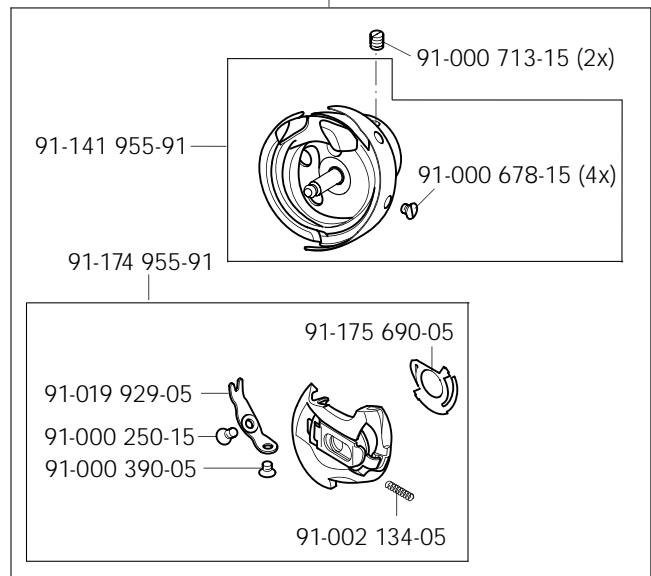

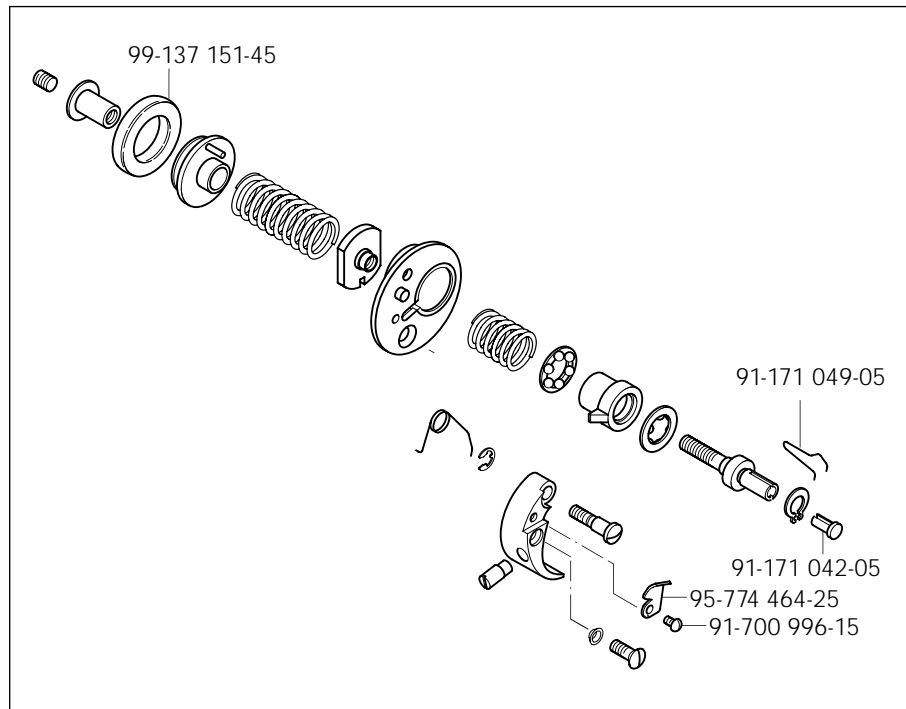

PFAFF 335-900/52

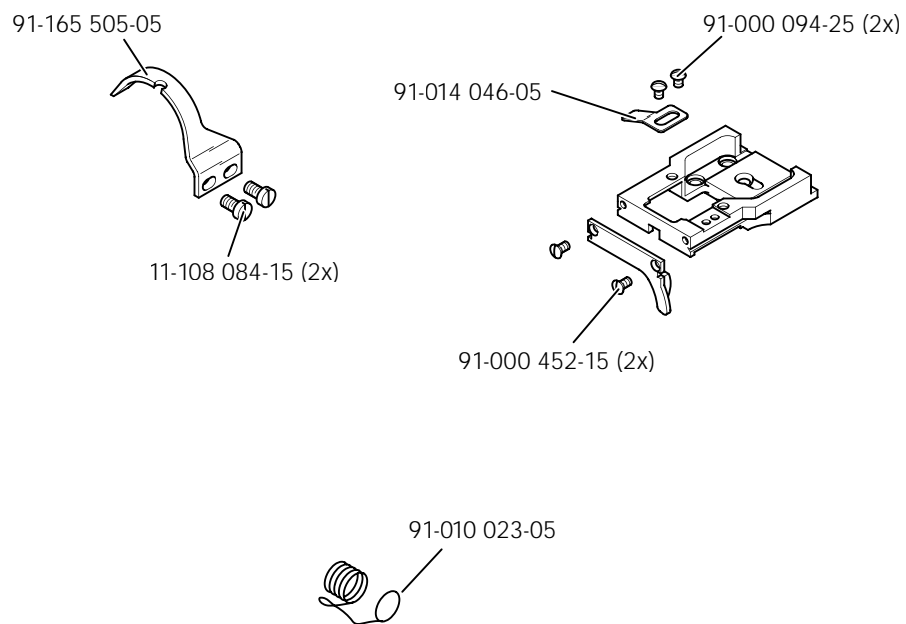



**Europäische Union**  
Wachstum durch Innovation – EFRE

## PFAFF Industriesysteme und Maschinen AG

Hans-Geiger-Str. 12 - IG Nord  
D-67661 Kaiserslautern

Phone: +49-6301 3205 - 0  
Fax: +49-6301 3205 1386  
E-mail: [info@pfaff-industrial.com](mailto:info@pfaff-industrial.com)

### Hotlines:

Technical service: +49-175/2243-101  
Application consultancy: +49-175/2243-102  
Spare-parts hotline: +49-175/2243-103

Printed in Germany