

# 3511-2/01

## INSTRUCTION MANUAL

This instruction manual applies to machines from the following serial numbers **2 736 439** and software version **1-912-19** onwards:

The reprinting, copying or translation of PFAFF Instruction Manuals, whether in whole or in part, is only permitted with our previous authorization and with written reference to the source.

**PFAFF Industriesysteme  
und Maschinen AG**

Hans-Geiger-Str. 12 - IG Nord  
D-67661 Kaiserslautern

---

	Contents .....	Page
<b>1</b>	<b>Safety .....</b>	<b>6</b>
<b>1.01</b>	<b>Directives .....</b>	<b>6</b>
1.02	General notes on safety .....	6
1.03	Safety symbols .....	7
1.04	Important points for the user .....	7
1.05	Operating and specialist personnel .....	8
1.05.01	Operating personnel .....	8
1.05.02	Specialist personnel .....	8
1.06	Danger warnings .....	9
<b>2</b>	<b>Proper use .....</b>	<b>10</b>
<b>3</b>	<b>Specifications .....</b>	<b>11</b>
<b>4</b>	<b>Disposal of Machine .....</b>	<b>12</b>
<b>5</b>	<b>Transportation, packing and storage .....</b>	<b>13</b>
5.01	Transportation to customer's premises .....	13
5.02	Transportation inside the customer's premises .....	13
5.03	Disposal of packing materials .....	13
5.04	Storage .....	13
<b>6</b>	<b>Explanation of symbols .....</b>	<b>14</b>
<b>7</b>	<b>Controls .....</b>	<b>15</b>
7.01	On/off switch .....	15
7.02	Lever for lifting the presser foot .....	15
7.03	Pedal .....	16
7.04	Photo sensor .....	16
7.05	Control panel .....	17
7.05.01	Screen displays .....	17
7.05.02	Symbole im Display .....	17
7.05.03	Function keys .....	18
<b>8</b>	<b>Installation and commissioning .....</b>	<b>21</b>
8.01	Installation .....	21
8.01.01	Adjusting the table height .....	21
8.01.02	Mounting the spool holder .....	22
8.01.03	Connecting the plug-in connections and earth cables .....	23
8.02	Commissioning .....	24
8.03	Switching the machine on/off .....	24
8.04	Basic position of the machine drive unit .....	25
<b>9</b>	<b>Preparation .....</b>	<b>26</b>
9.01	Inserting the needle .....	26
9.02	Winding the bobbin thread, adjusting the thread tension .....	27
9.03	Removing / Inserting the bobbin case .....	28
9.04	Inserting the bobbin case / Adjusting the bobbin thread tension .....	28
9.05	Threading the needle thread / Adjusting the needle thread tension .....	29

---

	Contents .....	Page
9.06	Entering the stitch length.....	30
9.07	Entering the start and end backtacks.....	30
9.08	Inserting and removing the SD-memory card.....	31
9.09	Inserting the workpiece .....	32
9.09.01	Loading the sewing jig .....	32
9.09.02	Inserting the sewing jig.....	33
<b>10</b>	<b>Sewing .....</b>	<b>34</b>
10.01	Manual sewing .....	35
10.02	Programmed sewing.....	36
10.03	Creating / altering seam patterns.....	37
10.03.01	Creating a seam pattern in the "teach in mode".....	37
10.03.02	Altering seam patterns.....	41
10.03.03	Switch on edge trimmer with delay (waistband extension) .....	42
10.04	Program management .....	43
10.04.01	Calling up the program management .....	43
10.04.02	Displaying programs in the machine memory .....	44
10.04.03	Displaying programs on the SD-memory card.....	45
10.04.04	Copying individual programs to the SD-memory card .....	46
10.04.05	Copying all programs to the SD-memory card.....	47
10.04.06	Copying individual programs to the machine memory.....	48
10.04.07	Copying all programs to the machine memory .....	49
10.04.08	Deleting programs in the machine memory .....	50
10.04.09	Deleting programs on the SD-memory card.....	51
10.04.10	Formatting the SD-memory card .....	52
10.05	Error messages.....	52
<b>11</b>	<b>Care and maintenance.....</b>	<b>53</b>
11.01	Maintenance intervals.....	53
11.02	Cleaning the machine .....	53
11.03	Topping up the oil tank.....	54
11.04	Checking/regulating the air pressure .....	54
11.05	Emptying/cleaning the water bowl of the air filter/regulator.....	55
<b>12</b>	<b>Adjustment.....</b>	<b>56</b>
12.01	Notes on adjustment .....	56
12.02	Tools, gauges and other accessories for adjusting .....	56
12.03	Abbreviations .....	56
12.04	Checking and adjusting aids.....	57
12.05	Adjusting the basic machine .....	58
12.05.01	Basic position of the machine drive .....	58
12.05.02	Preadjusting the needle height .....	59
12.05.03	Needle in needle hole center.....	60
12.05.04	Hook shaft bearing and toothed belt tension.....	61
12.05.05	Hook lubrication .....	62
12.05.06	Needle rise, hook-to-needle clearance, needle height and bobbin case position finger .....	63
12.05.07	Thread check spring and slack thread regulator .....	64
12.05.08	Bobbin winder.....	65
12.05.09	Presser foot pressure .....	66
12.06	Adjusting the edge trimmer.....	67
12.06.01	Zero position of the knife .....	67
12.06.02	Cutting motion .....	68

---

---

Contents .....		Page
12.06.03	Knife height.....	69
12.06.04	Knife position in sewing direction .....	70
12.06.05	Cutting angle of the knife.....	71
12.06.06	Knife position crosswise to sewing direction .....	72
12.07	Adjusting the thread trimming device.....	73
13.0.01	Adjusting the solenoid / preliminary adjustment of the control cam .....	73
12.07.02	Lateral alignment of the thread catcher .....	74
12.07.03	Knife position .....	75
12.07.04	Front point of reversal of the thread catcher.....	76
12.07.05	Manual trimming check.....	77
12.07.06	Needle thread tension release.....	78
12.07.07	Readjusting the control cam .....	79
12.08	Adjusting the automatic presser foot lift.....	80
12.09	Adjusting the jig drive .....	81
12.09.01	Position of the jig drive in the sewing direction .....	81
12.09.02	Position of the jig drive crosswise to the sewing direction.....	82
12.09.03	Jig drive contact pressure.....	83
12.09.04	Adjusting the support roller.....	84
12.10	Adjusting the retainer .....	85
12.11	Adjusting the photo sensor and jig stop .....	86
12.12	Parameter settings.....	87
12.12.01	Selecting the user level.....	87
12.12.02	Example of parameter input .....	88
12.12.03	List of parameters.....	89
12.13	Explanation of the error messages .....	93
12.13.01	Sewing motor errors .....	93
12.13.02	Error SD memory card.....	93
12.14	Hardware-Test.....	94
12.14.01	Carry out the hardware test.....	94
12.14.02	Test block 1 – inputs .....	94
12.14.03	Test block 2 – outputs .....	95
12.14.04	Test block 3 – Set value sender and actual value sender .....	95
12.14.05	Test block 4 – photo sensor and thread monitor.....	96
12.15	Reset .....	96
12.16	Internet update of the machine software .....	97
<b>13</b>	<b>Wearing parts .....</b>	<b>98</b>
<b>14</b>	<b>Circuit diagram.....</b>	<b>100</b>

---

## 1 Safety

### 1.01 Directives

This machine is constructed in accordance with the European regulations contained in the conformity and manufacturer's declarations.

In addition to this Instruction Manual, also observe all generally accepted, statutory and other regulations and legal requirements and all valid environmental protection regulations! The regionally valid regulations of the social insurance society for occupational accidents or other supervisory organizations are to be strictly adhered to!

### 1.02 General notes on safety

- This machine may only be operated by adequately trained operators and only after having completely read and understood the Instruction Manual!
- All Notes on Safety and Instruction Manuals of the motor manufacturer are to be read before operating the machine!
- The danger and safety instructions on the machine itself are to be followed!
- This machine may only be used for the purpose for which it is intended and may not be operated without its safety devices. All safety regulations relevant to its operation are to be adhered to.
- When exchanging sewing tools (e.g. needle, roller presser, needle plate and bobbin), when threading the machine, when leaving the machine unattended and during maintenance work, the machine is to be separated from the power supply by switching off the On/Off switch or by removing the plug from the mains!
- Everyday maintenance work is only to be carried out by appropriately trained personnel!
- Repairs and special maintenance work may only be carried out by qualified service staff or appropriately trained personnel!
- Work on electrical equipment may only be carried out by appropriately trained personnel!
- Work is not permitted on parts and equipment which are connected to the power supply! The only exceptions to this rule are found in the regulations EN 50110.
- Modifications and alterations to the machine may only be carried out under observance of all the relevant safety regulations!
- Only spare parts which have been approved by us are to be used for repairs! We expressly point out that any replacement parts or accessories which are not supplied by us have not been tested and approved by us. The installation and/or use of any such products can lead to negative changes in the structural characteristics of the machine. We are not liable for any damage which may be caused by non-original parts.

## 1.03 Safety symbols



Danger!  
Points to be observed..



Danger of injury for operating and specialist personnel!



### Caution

Do not operate without finger guard and safety devices.  
Before threading, changing bobbin and needle, cleaning etc. **switch off main switch.**

## 1.04 Important points for the user

- This Instruction Manual is an integral part of the machine and must be available to the operating personnel at all times.
- The Instruction Manual must be read before operating the machine for the first time.
- The operating and specialist personnel is to be instructed as to the safety equipment of the machine and regarding safe work methods.
- It is the duty of the user to only operate the machine in perfect running order.
- It is the obligation of the user to ensure that none of the safety mechanisms are removed or deactivated.
- It is the obligation of the user to ensure that only authorized persons operate and work on the machine.

Further information can be obtained from your PFAFF agent.

## 1.05 Operating and specialist personnel

### 1.05.01 Operating personnel

Operating personnel are persons responsible for the equipping, operating and cleaning of the machine as well as for taking care of problems arising in the sewing area.

The operating personnel is required to observe the following points and must:

- always observe the Notes on Safety in the Instruction Manual!
- never use any working methods which could adversely affect the safety of the machine!
- not wear loose-fitting clothing or jewelery such as chains or rings!
- also ensure that only authorized persons have access to the potentially dangerous area around the machine!
- always immediately report to the person responsible any changes in the machine which may limit its safety!

### 1.05.02 Specialist personnel

Specialist personnel are persons with a specialist education in the fields of electrics, electronics and mechanics. They are responsible for the lubrication, maintenance, repair and adjustment of the machine.

The specialist personnel is obliged to observe the following points and must:

- always observe the Notes on Safety in the Instruction Manual!
- switch off the On/Off switch before carrying out adjustments or repairs, and ensure that it cannot be switched on again unintentionally!
- wait until the luminous diode on the control box is no longer blinking or on before beginning adjustment or repair work.
- never work on parts which are still connected to the power supply! Exceptions are explained in the regulations EN 50110.
- replace the protective coverings and close the electrical control box after all repairs or maintenance work!



## 1.06 Danger warnings



A working area of 1 m must be kept free both in front of and behind the machine, so that easy access is possible at all times.



Never put your hands or fingers in the sewing area during sewing!  
Danger of injury by the needle!



While setting or adjusting the machine do not leave any objects on the table nor in the needle plate area! Objects may be trapped or flung out of the machine!

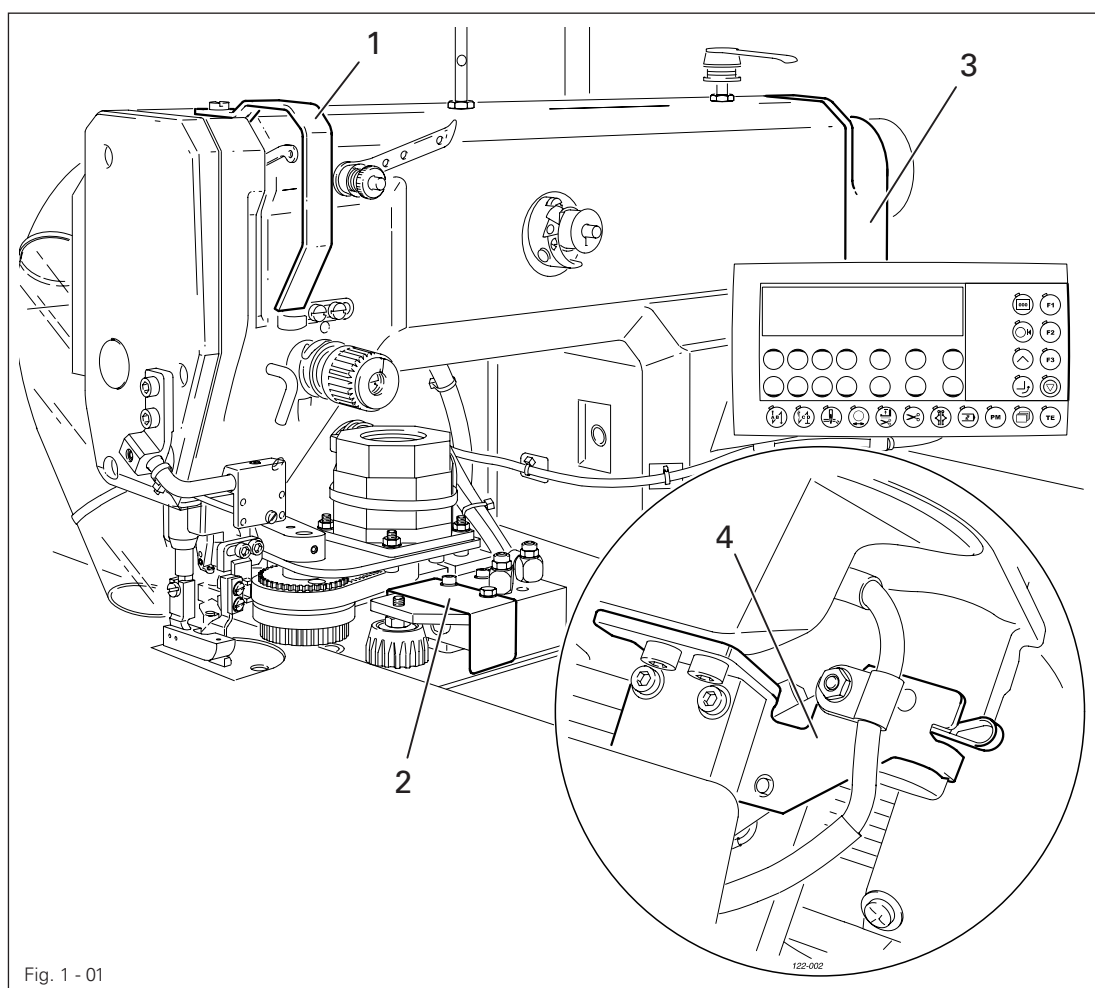

Do not run the machine without take-up lever guard **1!**  
Danger of injury by moving take-up lever!



Do not operate the machine without covers **2** and **3!**  
Danger of injury from moving parts!



Do not operate the machine without start inhibitor **4!**  
Danger of injury if the machine is started accidentally!

### 2 Proper use

The PFAFF 3511-2/01 is an ultra-high-speed, single-needle lockstitch sewing machine for stitching and turning small parts.



Any and all uses of this machine which have not been approved of by the manufacturer are considered to be inappropriate! The manufacturer cannot be held liable for any damage caused by the inappropriate use of the machine! The appropriate use of the machine includes the observance of all operational, adjustment, maintenance and repair measures required by the manufacturer!

## 3 Specifications ▲

Stitch type:.....	301 (lockstitch)
Needle system:.....	134 KK
Needle size in 1/100 mm: .....	80 -100
Max. stitch length: .....	3,5 mm
Max. speed: .....	3000 Sti/min♦
Trimming margin (depends on version).....	3.5 or 5.0 mm
Bed-plate dimensions: .....	476 x 177 mm
Dimensions of machine:	
Length:.....	approx. 1250 mm
Width: .....	approx. 800 mm
Height (above table):.....	approx. 300 mm
Electrical data	
Power supply:.....	230 V ± 10 %, 50/60 Hz
Max. output: .....	400 VA
Fuse protection: .....	1 x 16 A, inert
Working air pressure:.....	6 bar
Air consumption:.....	approx. 25 l/work cycle
Noise data:	
Noise emission level at workplace with a sewing speed of 2000 spm: .....	$L_{pA} = 78$ dB(A) ■
(Noise measurement in accordance with DIN 45 635-48-B-1, ISO 11204, ISO 3744, ISO 4871)	
Net weight: .....	approx. 105 kg
Gross weight .....	approx. 176 kg

▲ Subject to alterations

♦ The max. speed is reduced automatically depending on the stitch length.

■  $K_{pA} = 2,5$  dB

4

### **Disposal of Machine**

- Proper disposal of the machine is the responsibility of the customer.
- The materials used for the machine are steel, aluminium, brass and various plastic materials. The electrical equipment comprises plastic materials and copper.
- The machine is to be disposed of according to the locally valid pollution control regulations; if necessary, a specialist is to be commissioned.



Care must be taken that parts soiled with lubricants are disposed of separately according to the locally valid pollution control regulations!

### **5 Transportation, packing and storage**

#### **5.01 Transportation to customer's premises**

The machines are delivered completely packed.

#### **5.02 Transportation inside the customer's premises**

The manufacturer cannot be made liable for transportation inside the customer's premises nor to other operating locations. It must be ensured that the machines are only transported in an upright position.

#### **5.03 Disposal of packing materials**

The packing materials of this machine comprise paper, cardboard and VCE fibre. Proper disposal of the packing material is the responsibility of the customer.

#### **5.04 Storage**

If the machine is not in use, it can be stored as it is for a period of up to six months, but it should be protected against dust and moisture.

If the machine is stored for longer periods, the individual parts, especially the surfaces of moving parts, must be protected against corrosion, e.g. by a film of oil.

---

## Explanation of symbols

---

### 6 Explanation of symbols

In this instruction manual, work to be carried out or important information is accentuated by symbols. These symbols have the following meanings:



Note, information



Cleaning, care



Lubrication

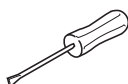

Maintenance, repairs, adjustment, service work  
(only to be carried out by technical staff)

7 Controls

7.01 On/off switch

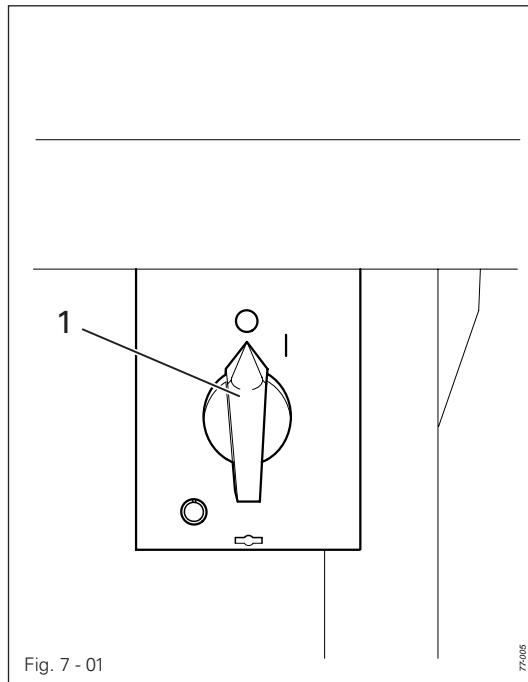

- Switch the machine on or off by turning main switch 1.

7.02 Lever for lifting the presser foot

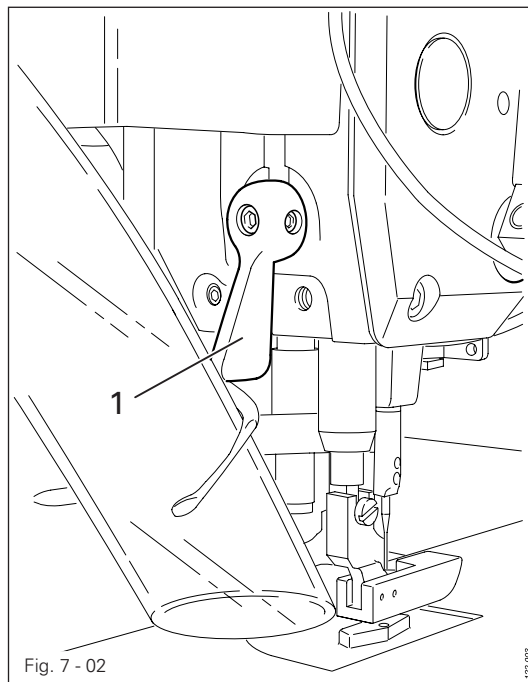

- The presser foot is raised by turning lever 1.

## 7.03 Pedal

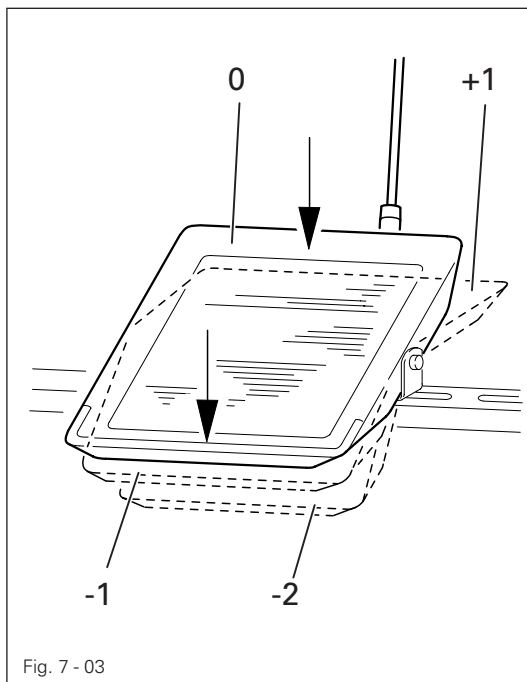

The pedal functions depend on the selected operating mode, see Chapter 10 Sewing.

### In manual sewing:

- +1 = sewing
- 0 = neutral position
- 1 = raise sewing foot
- 2 = cut thread

### In programmed sewing:

- +1 = start sewing cycle
- 0 = neutral position
- 1 = no function
- 2 = seam stop.

## 7.04 Photo sensor

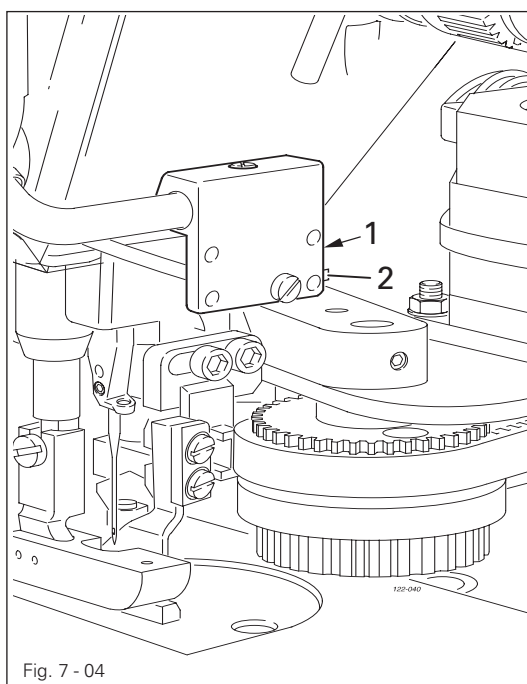

The LED 1 in the photo sensor indicates the following status:

- LED shows green light = indicates reception
- LED shows green flashing light = adjustment aid / indicates soiling
- LED shows yellow light = indicates ready status

Button 2 on the photo sensor is used to adjust the photo sensor, see Chapter 12.11 Adjusting the photo sensor.



7.05 Control panel

The control panel is used to call up machine functions for setting up the machine and for sewing operation, for entering parameter values and for reading error messages and service settings.

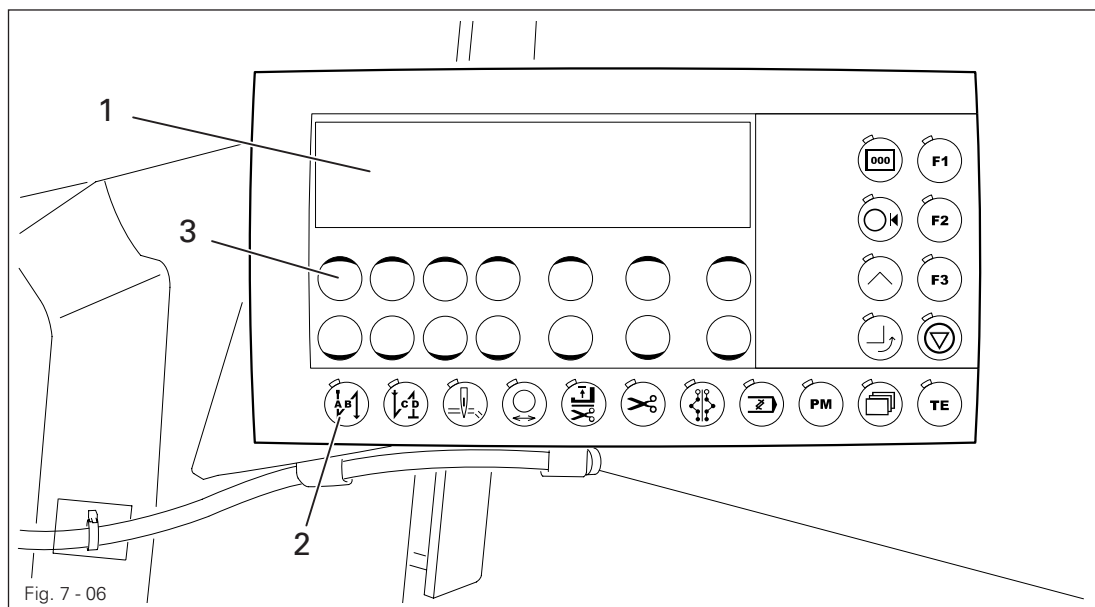

The control panel consists of display screen 1 with the function keys described below. The display 1 consists of a two-row alphanumerical LCD display with 16 symbols per row. The function keys 2 are located below and to the right of the display screen. The status of the function keys and the machine operating modes are shown with LEDs in the corresponding keys. Every time the function keys 2 are operated, a key tone sounds as confirmation of the input. If the input required is invalid, e.g. because the max. permissible value for the parameter input has been reached, a double tone is audible. An SD-card reader for data transfer is integrated.

7.05.01 Screen displays

- In the sewing mode all relevant sewing data is displayed and can be changed directly, depending on the status of the machine, see also Chapter 10 Sewing.
- During the parameter input the selected parameter number with the corresponding value is displayed, see Chapter "12.12 Parameter settings".



7.05.02 Symbole im Display

- ▢ Program
- Machine memory
- ▭ SD-memory card
- ↵ Enter
- ∧ Program with corners

## 7.05.03 Function keys

The functions keys described below are used essentially to switch machine functions on and off. When the function is switched on, the **diode in the key is illuminated**.

If a corresponding value has to be fixed for the activated function, this can be carried out with the corresponding +/- keys 3.

-  By pressing and holding the corresponding +/- **key**, firstly the numerical value displayed above it is altered slowly. If the +/- **key** is pressed longer, the numerical value changes more quickly. The respective +/- **keys** shown opposite are described below.
- 



### Start backtacks

- If this key is pressed, the backtack function at the beginning of the seam (start backtacks) is switched on or off. In manual sewing the number of forward stitches (A) or reverse stitches (B) for the start backtacks can be changed respectively by pressing the +/- key underneath. To convert from double backtack to single backtack, reset the number of stitches for the corresponding seam section.



### End backtacks

- If this key is pressed, the backtack function at the end of the seam (end backtacks) is switched on or off. In manual sewing the number of reverse stitches (C) or forward stitches (D) can be changed respectively by pressing the +/- key underneath. To convert from double backtack to single backtack, reset the number of stitches for the corresponding seam section.



### Edge trimmer

- Press this key to switch the edge trimming knife on or off.



### Jig drive

- Press this key to switch the jig drive unit on or off.



### Foot position after trimming

- If this key is pressed the "foot raised after thread trimming" function is switched on or off. When the function is switched on, the presser foot is raised after thread trimming.



### Thread trimmer

- If this key is pressed the thread trimming function is switched on or off.



### Alternate sewing

- If this key is pressed, it is possible to switch between the linked programs.



## Sewing / correcting seam programs

- If this key is pressed, the sewing/correcting seam programs function is switched on. By operating the pedal, the individual seam sections of a program can be sewn after each other and corrected if necessary.



## PM

- Press this key to switch the sewing of programmed seam patterns on or off. The specific program parameters are shown in the alphanumerical section of the display.



## Line selection

- If this key is pressed, the activated line in the display is selected. Parameter alterations can only be made in the current active line. If this function is switched on, the top line of the display is active.



## TE

- If this key is pressed in the sewing mode, the machine changes to the parameter input function.
- If this key is pressed during the seam pattern input the "teach in mode" is selected.
- If this key is pressed during the parameter input, the altered values are stored and the sewing mode is called up.
- Press this key twice to call up the program management function, see Chapter 10.04 Program Management.



## Piece Counter

- Press this key to switch the piece counter on or off. When the function is switched on the actual value is shown on the display.



## Support roller

- If this key is pressed during seam programming, the support roller function for the corresponding section of the seam pattern is switched on or off. In programmed sewing with the seam pattern the support roller retracts in the appropriate seam section.



## Corner programming

- If this key is pressed, the corresponding function is switched on or off. If the function is switched on, the corner programming function is carried out for the appropriate section of the seam pattern.



## Turning the corner

- If this key is pressed, the corresponding function is switched on or off. If the function is switched on, the "turning the corner" function for the current seam section is carried out for the segment shown on the display.



F1 (cycle time)

- If this key is pressed, the display function for the cycle time (duration of a seam sequence) is switched on or off.



F2 (adjustment aid for the edge trimmer)

- If this key is pressed, the corresponding function is switched on or off. If the function is switched on in the manual sewing mode, the edge trimmer moves to the cutting position.



F3

- After the corresponding "PC" (piece counter) function has been selected, press the key to reset the piece counter, see Chapter 10.03.03 **Switch on edge trimmer with delay** (waistband extension)



**Start inhibitor**

- Press this key to switch the start inhibitor on or off. When the function is switched on, sewing or the seam sequence cannot be started.

## 8 Installation and commissioning



The machine must only be installed and commissioned by qualified personnel! All relevant safety regulations must be strictly adhered to!  
If the machine is delivered without a table, be sure to use a stand and table top that can hold the weight of the machine with its motor.  
It is very important to ensure that the stand of the machine is firm and steady, also during sewing.

### 8.01 Installation

The site where the machine is installed must be provided with suitable connections for the electric current, see Chapter 3 **Specifications**.  
It must also be ensured that the standing surface of the machine site is firm and horizontal, and that sufficient lighting is provided.



For packing reasons the table top is in the lowered position. The table height is adjusted as described below.

#### 8.01.01 Adjusting the table height

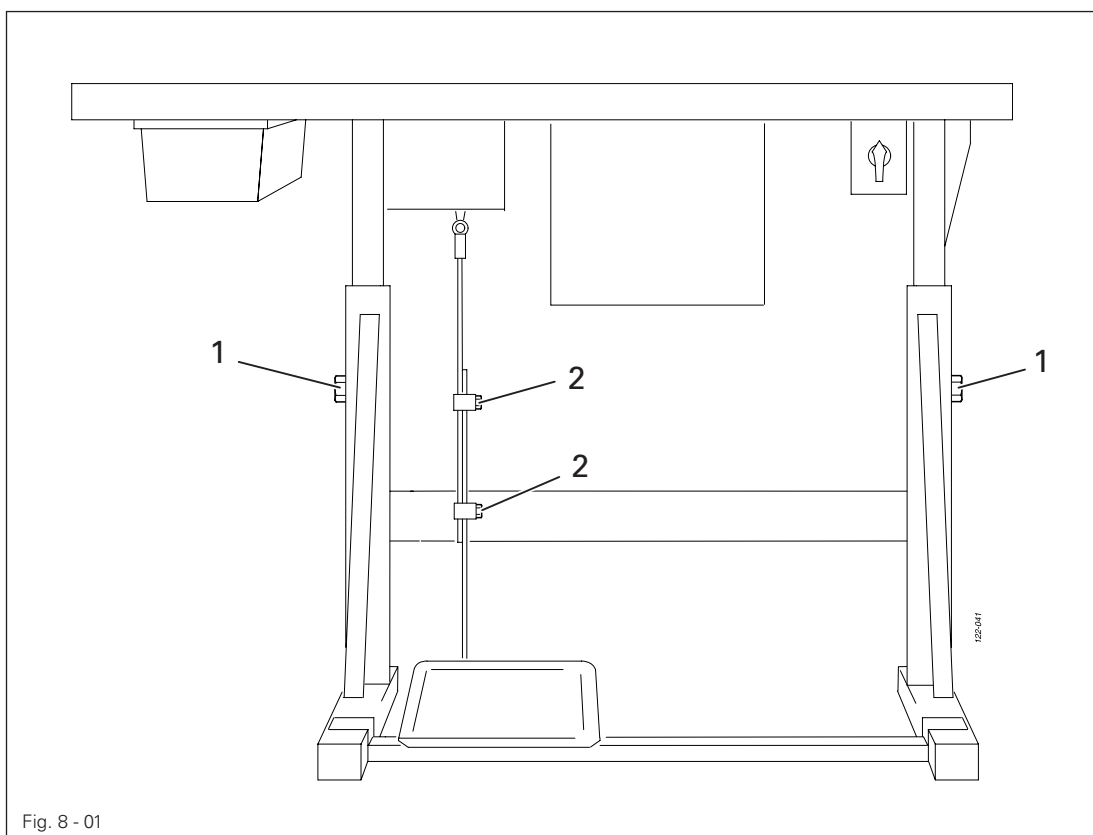

- Loosen screws 1 and 2 and set the table height as required.
- Firmly tighten screw 1.
- Set the required pedal position and tighten screws 2.

### 8.01.02 Mounting the spool holder

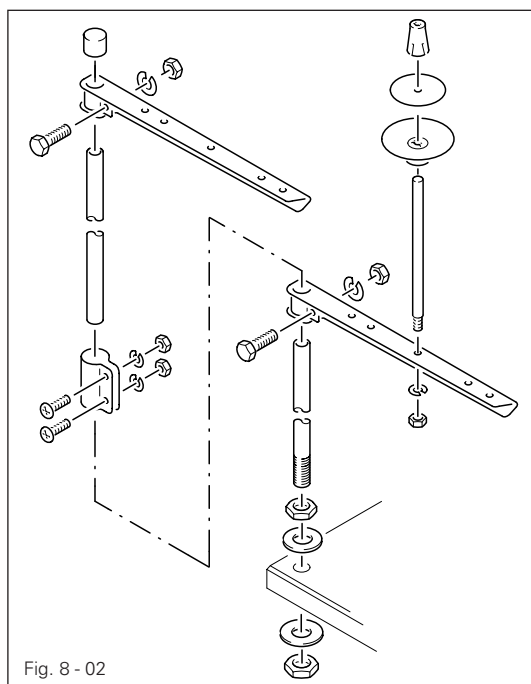

- Mount the spool holder as shown in Fig. 8-02.
- Insert the spool holder into the hole in the table top and fasten it with the nuts enclosed..

## 8.01.03 Connecting the plug-in connections and earth cables

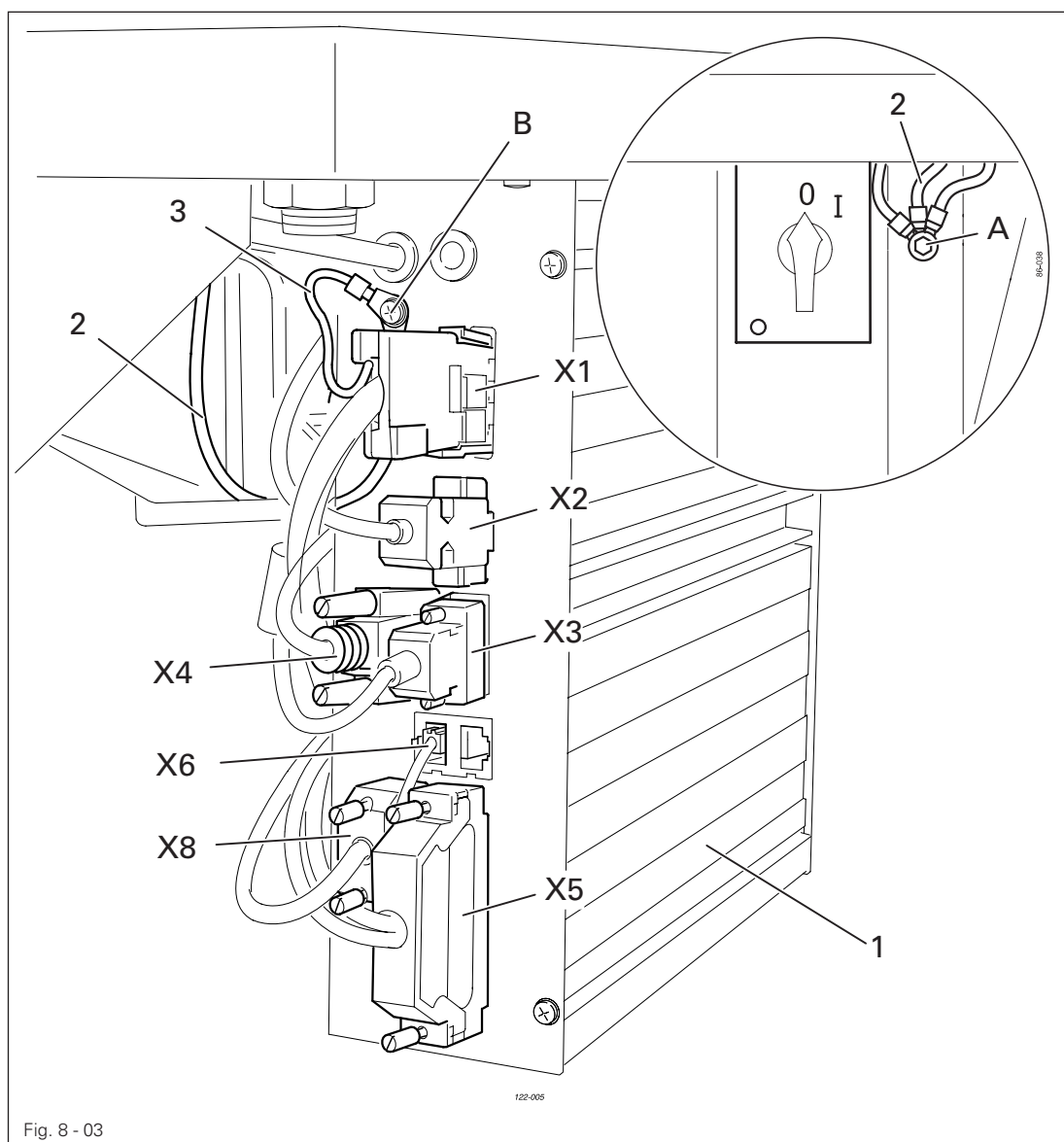
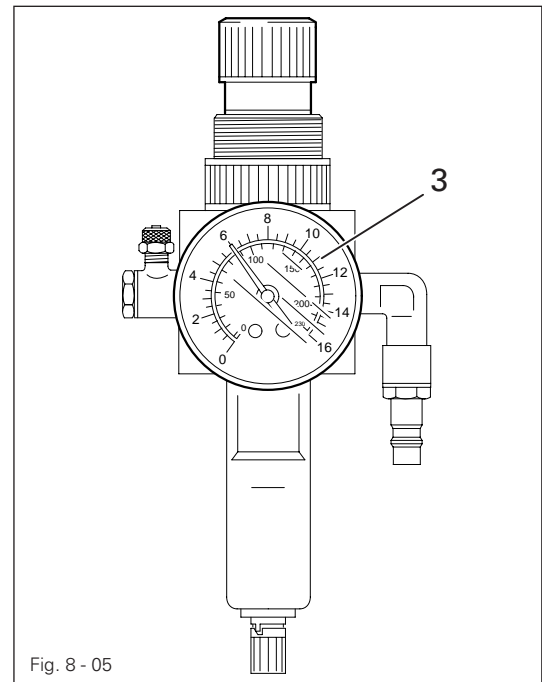
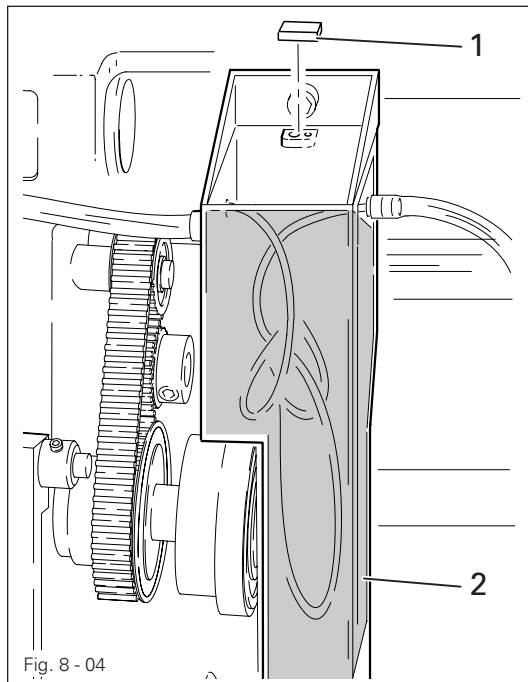

Fig. 8 - 03

- Connect all plugs as labelled to the control box 1.
- Screw the earth cable from the sewing head and the main switch to earth point A.
- Connect earth point A to earth point B with earth cable 2.
- Screw the earth cable 3 from the motor to earth point B.

## 8.02 Commissioning



- Check the machine, especially the electrical leads, for any damage
- Before commissioning the machine, remove grommet 1 of oil container 2.



Grommet 1 is only needed for support during transportation and must not be used while the machine is in operation.

- Clean the machine thoroughly and oil it (see chapter 11 **Care and maintenance**).
- Connect the machine to the compressed air supply. When it is connected, the gauge should show a pressure of approx. 6 bar. If necessary, have this reading correctly set (see Chapter 11.04, **Checking / adjusting the air pressure**).
- Have skilled personnel check if the machine can be operated with the available mains voltage.



Do not operate the machine if there is any discrepancy.



The machine may only be connected to an earthed socket!

- When the machine is running, the balance wheel must turn towards the operator. If this is not the case, have the motor adjusted by specialist staff, see Chapter 12.12 **Parameter settings**.

## 8.03 Switching the machine on/off

- Switch the machine on (see Chapter 7.01, **On/off switch**).



## 8.04 Basic position of the machine drive unit

- Activate service level "c", see Chapter 12.12.01 Selecting the user level.

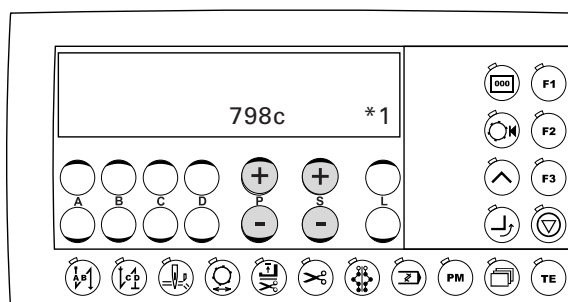

- Call up parameter "700" by pressing the +/- keys (P) or (S).

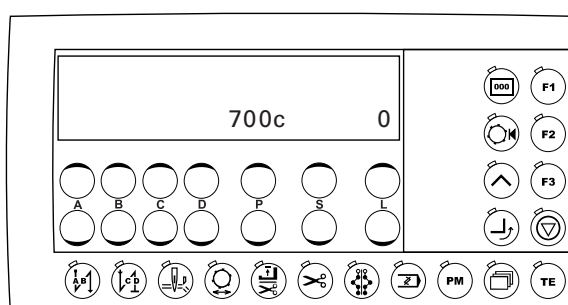

- Use the pedal function to sew one stitch.
- Turn the balance wheel in the sewing direction until the lower edge of the descending needle eye is level with the upper edge of the needle plate.



- Conclude the adjustment of the sewing motor by pressing the "TE" key.

9

## Preparation



All regulations and instructions in this Instruction Manual are to be observed!  
Special attention is to be paid to the safety regulations!



All preparation work is only to be carried out by appropriately trained personnel.  
Before all preparation work, the machine is to be separated from the electricity supply by removing the plug from the mains or switching off the On/Off switch!

9.01

## Inserting the needle

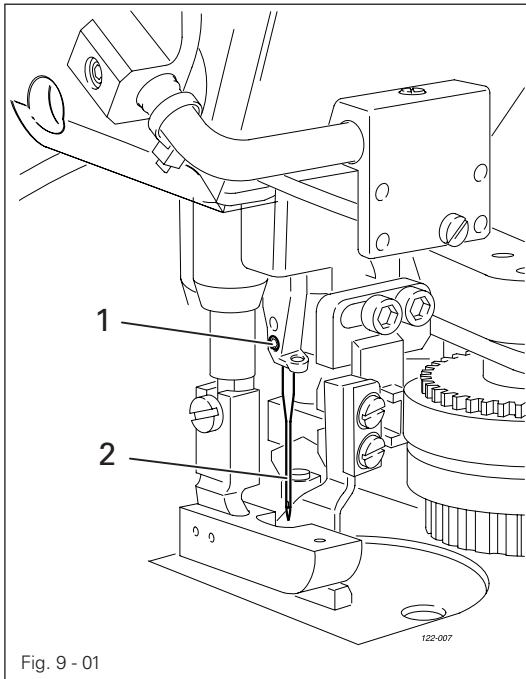

Fig. 9 - 01



Switch off the machine!  
Danger of injury due to unintentional starting of the machine!



Only use needles from the system intended for the machine, see Chapter 3 Specifications.

- Raise needle bar.
- Loosen screw 1 and insert needle 3 until you feel it stop.
- The long needle groove must be aligned in the direction of the machine head.
- Tighten screw 1.

## 9.02 Winding the bobbin thread, adjusting the thread tension

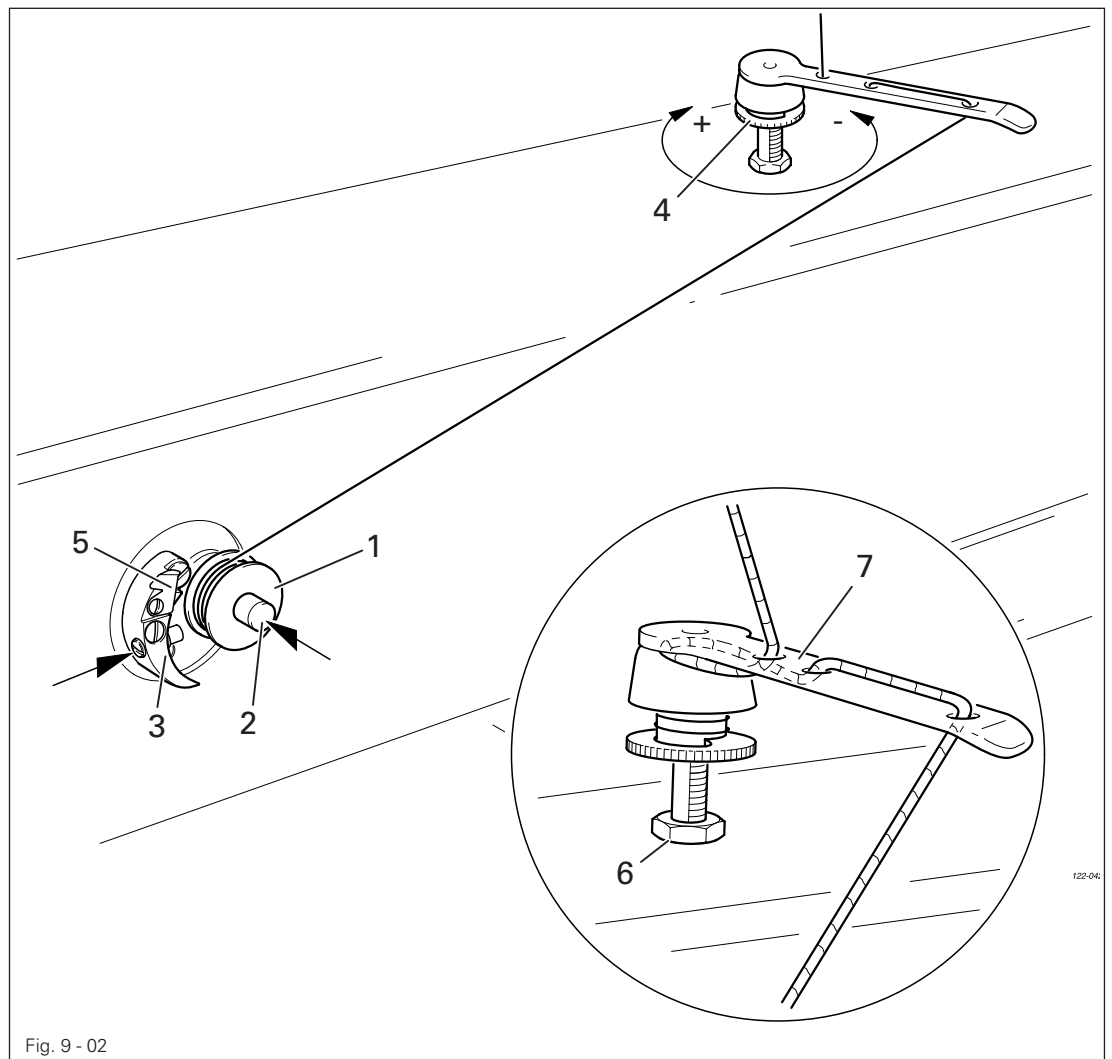

Fig. 9 - 02

- Place an empty bobbin 1 onto bobbin shaft 2.
- Thread the bobbin in accordance with Fig. 9-02 and wind it anti-clockwise around bobbin 1 a few times.
- Switch on the bobbin winder while at the same time pressing bobbin winder spindle 2 and lever 3.



The bobbin fills up during sewing.

- To adjust the bobbin winder tension turn knurled screw 4.
- The bobbin winder stops automatically, when bobbin 1 is filled sufficiently.
- Remove the filled bobbin 1 and cut the thread on knife 5.



If the thread is wound unevenly, loosen nut 6 and turn thread guide 7 accordingly. Retighten nut 6 after the adjustment.

## 9.03 Removing / Inserting the bobbin case

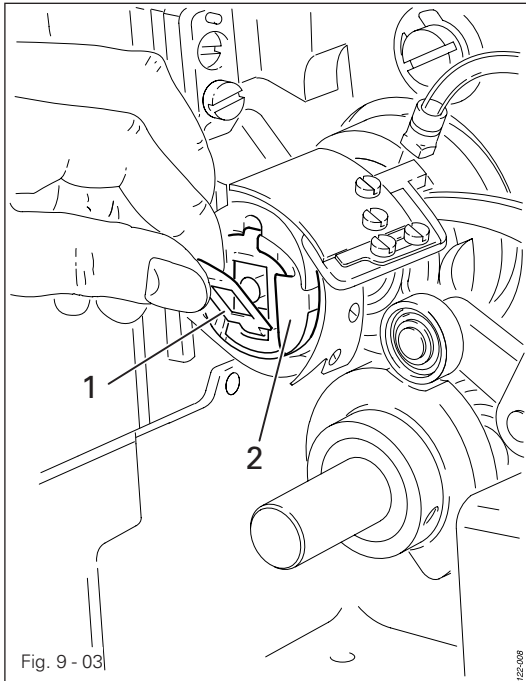

Switch off the machine!  
Danger of injury due to unintentional starting of the machine!

### Removing the bobbin case:

- Tilt back the machine.
- Raise latch 1 and remove bobbin case 2.

### Inserting the bobbin case:

- Press bobbin case 2 until you feel it snap into the bobbin case base.



Return the machine to its upright position using both hands!  
Danger of injury by crushing between the machine and the table top!

## 9.04 Inserting the bobbin case / Adjusting the bobbin thread tension

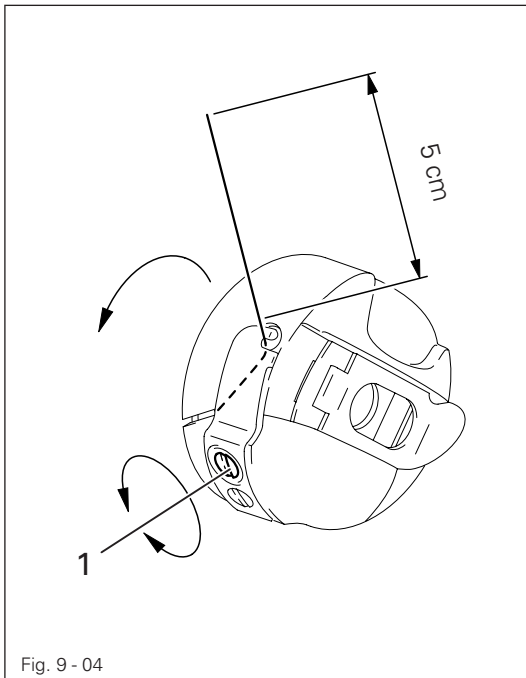

- Insert the bobbin into the bobbin case.
- Pass the thread through the slot under the spring according to Fig. 9-04.
- Pass the thread through the notch.
- Adjust the thread tension by turning screw 1



When the thread is pulled, the bobbin must rotate in the direction of the arrow.

## 9.05 Threading the needle thread / Adjusting the needle thread tension

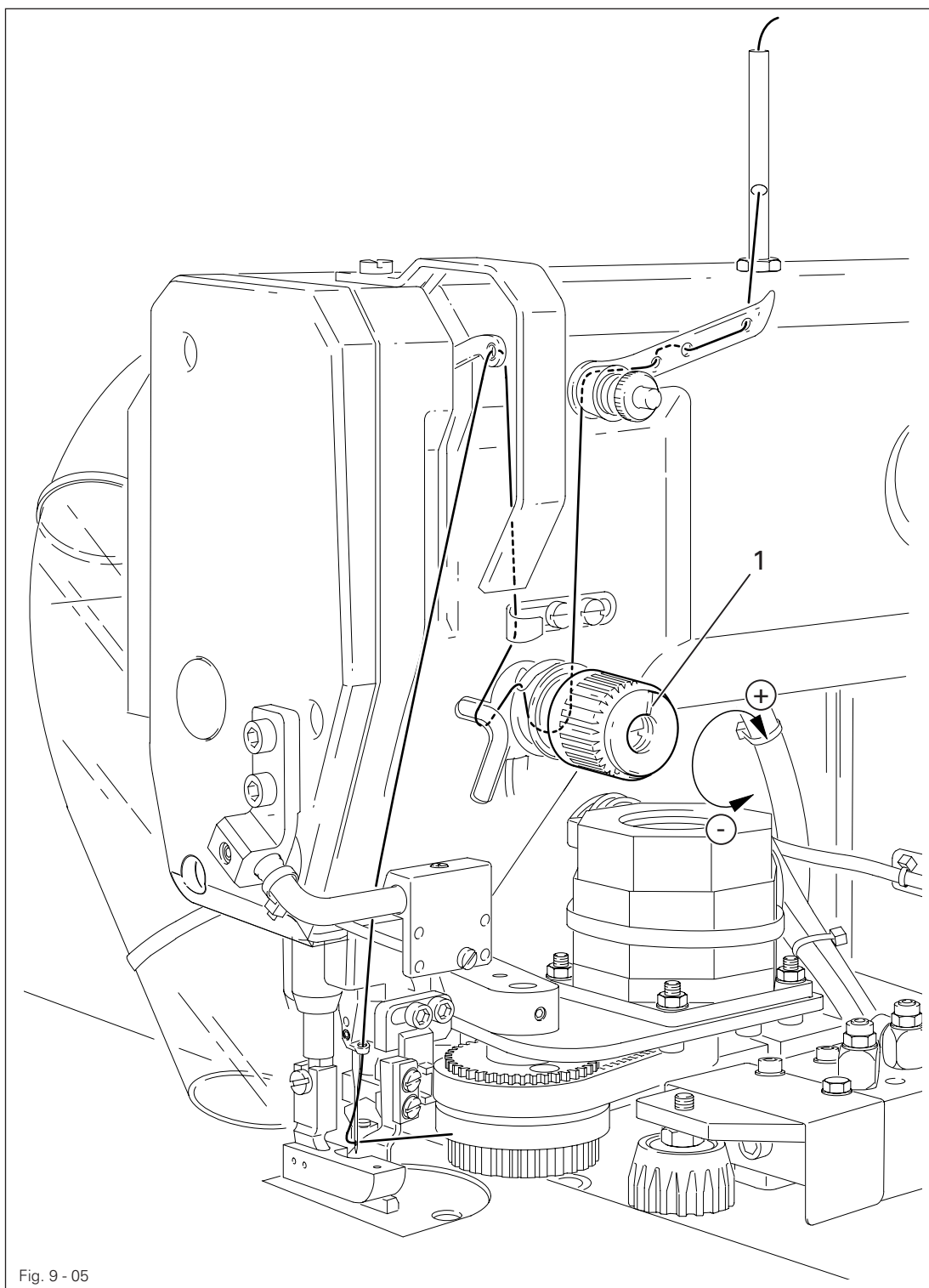

Switch off the machine!  
Danger of injury due to unintentional starting of the machine!

- Thread the machine as shown in Fig. 9-05.
- Adjust the needle thread tension by turning disk 1.

## 9.06 Entering the stitch length

- Activate mechanic level "b", see Chapter 12.12.01 **Selecting the user level**.



- Activate the top line (LED in the key is illuminated) by pressing the line selection key.

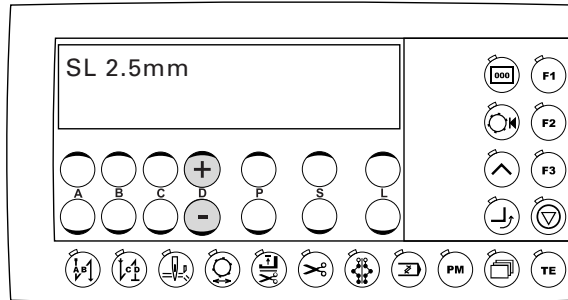

- Select the desired stitch length value by pressing the +/- keys (D).

## 9.07 Entering the start and end backtacks

- Switch on the machine.

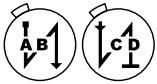

- Activate the corresponding function by pressing the keys **Start backtacks** and/or **End backtacks** (LED is illuminated).

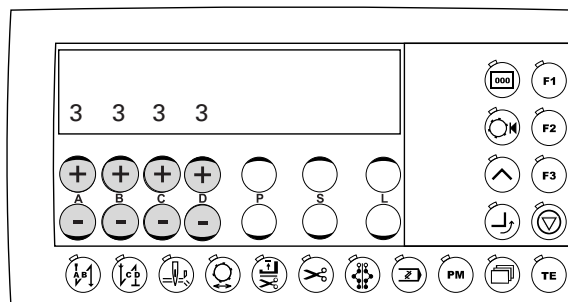

- By pressing the corresponding +/- key ("A") select the desired value for the number of forward stitches (A) of the start backtack.
- By pressing the corresponding +/- key ("B") select the desired value for the number of reverse stitches (B) of the start backtack.
- By pressing the corresponding +/- key ("C") select the desired value for the number of reverse stitches (C) of the end backtack.
- By pressing the corresponding +/- key ("D") select the desired value for the number of forward stitches (D) of the end backtack.

## 9.08 Inserting and removing the SD-memory card

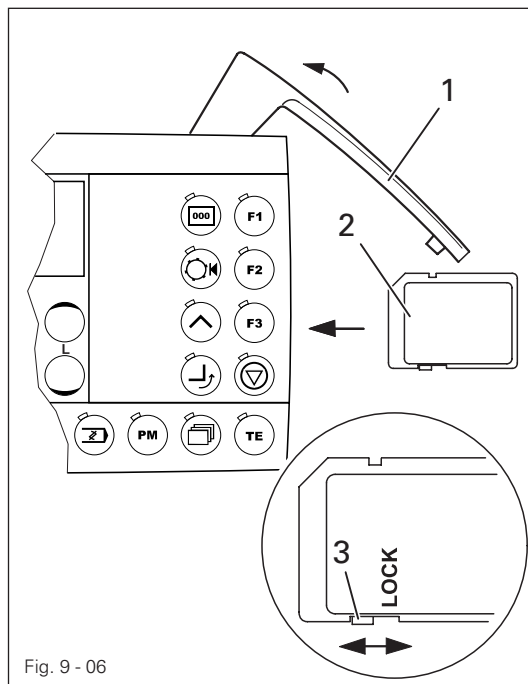

Fig. 9 - 06

**Inserting the SD-memory card**

- Open cover 1.
- Insert SD-memory card 2 into the card slot with the label at the front.
- Close cover 1 again.

**Removing the SD-memory card**

- Open cover 1.
- Press the edge of the SD-memory card 2 lightly – the SD-card is ejected.
- Close cover 1 again.



By moving slide 3 it is possible to activate (position "LOCK") or deactivate the write protection function of the SD-memory card. To store, process or delete data on the SD-memory card, the write protection function must be deactivated.

### 9.09 Inserting the workpiece

#### 9.09.01 Loading the sewing jig

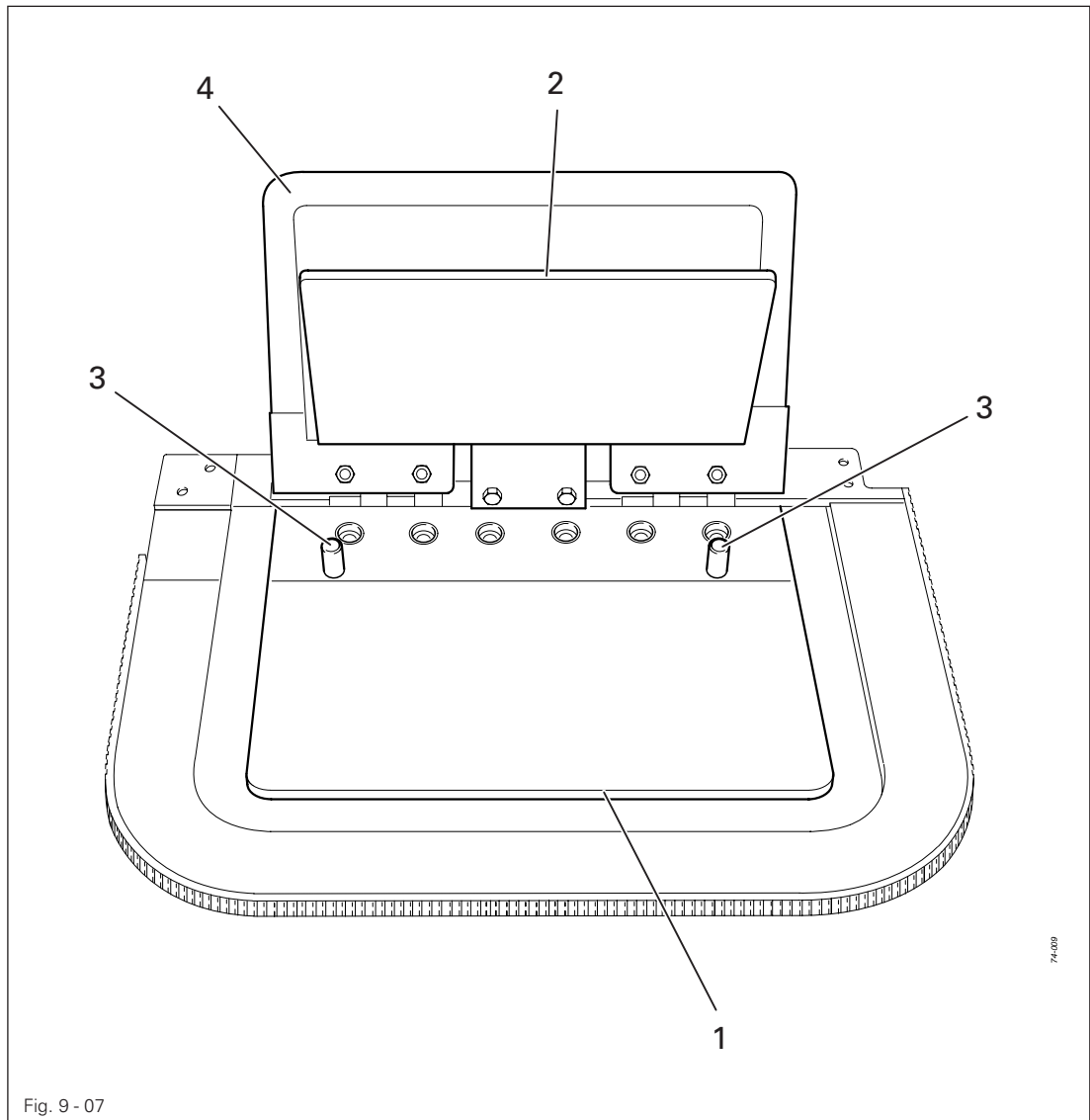
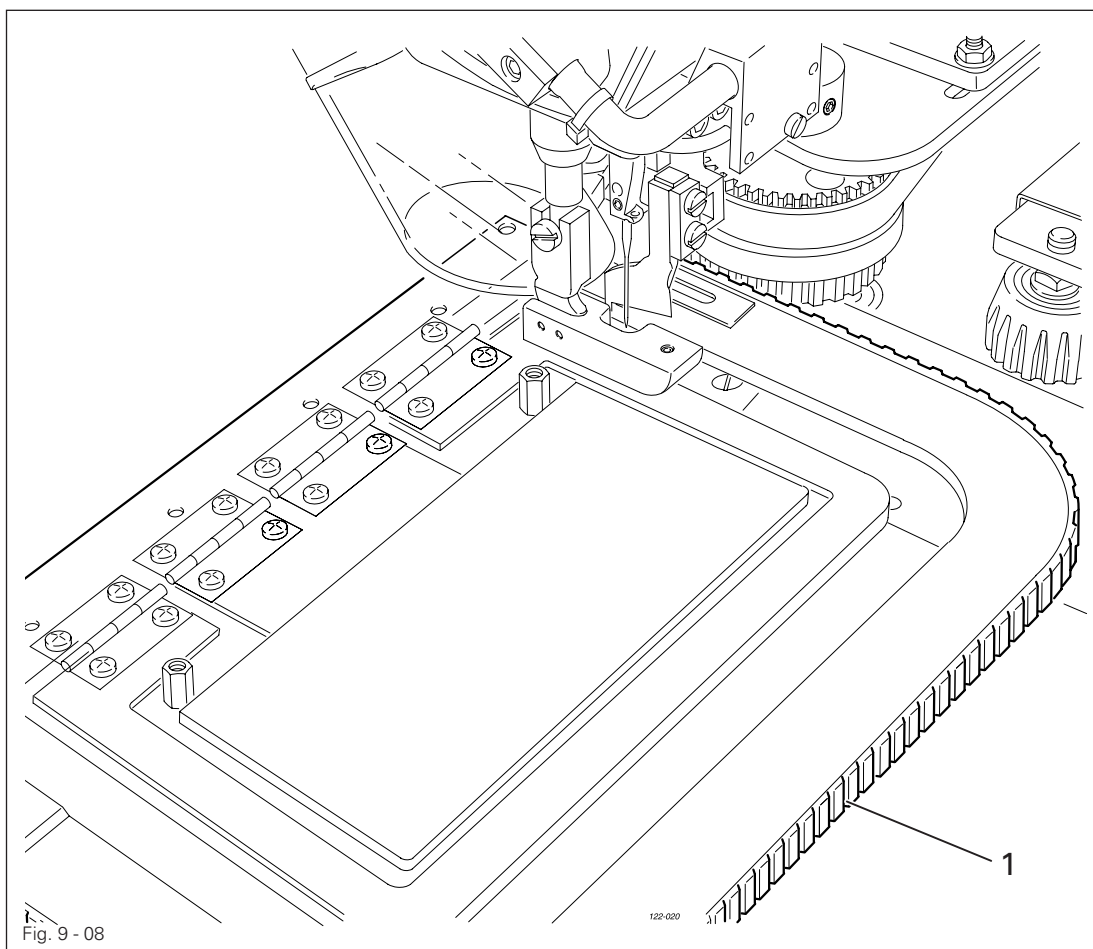

Fig. 9 - 07

- Insert the lining between cloth plate 1 and material clamp 2 so that it is touching guide pins 3.
- Close the material clamp 2.
- Place the preliminary cut workpiece for the fullness on material clamp 2 and close material clamp 4.



9.09.02 Inserting the sewing jig



- Position the sewing jig 1 in the guide bar on the needle plate and push it until it reaches the stop. The machine is ready for operation.



The machine may only be operated by appropriately trained personnel! The operating personnel must ensure that only authorised persons are in the danger area of the machine!

In addition to the input mode, in particular for production the sewing mode is available. Depending on the program selected and the machine status, in the sewing mode all sewing data relevant for the production is shown on the display. Standard operation is in the programmed sewing mode. It is possible to switch to the manual sewing mode to install and check operating sequences.

For sewing the following conditions must be fulfilled:

- All safety devices must be fitted, see Chapter **1.06 Danger warnings**.
- The machine must be properly installed and commissioned in accordance with Chapter **8 Installation and Commissioning**.
- All setting-up work must have been completed, see Chapter **9 Setting up**.

10.01 Manual sewing

The manual sewing mode is used for installing and checking. It is not normally used for production.







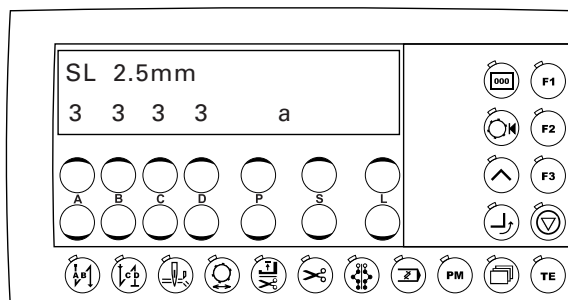





- Switch on the machine, see Chapter 8.03 Switching the machine on/off.



- If necessary call up the manual sewing mode. (The LED in the key is not illuminated.)



Functions in manual sewing, also see Chapter 7.04.03 Function keys:

- |   |   |   |                                      |
|---|---|---|--------------------------------------|
|   | Start backtacks on/off                          |   | Line selection*                      |
|  | End backtacks on/off                            |  | Parameter input / program management |
|  | Edge trimmer on/off                             |  | Piece counter display on/off         |
|  | Jig drive on/off                                |  | Support roller on/off                |
|  | Sewing foot raised after thread trimming on/off |  | Adjustment aid edge trimmer on/off   |
|  | Thread trimmer on/off                           |  | Start inhibitor on/off               |

\* The function is available from mechanic level "b" on, see Chapter 12.12.01 Selecting the user level.

- If necessary insert the workpiece, see Chapter 9.09 Inserting the workpiece.
- Sewing takes place with the pedal functions, see Chapter 7.03 Pedal.

## 10.02 Programmed sewing



For programmed sewing a seam pattern must have been created beforehand and stored in the machine memory, see Chapter 10.03 **Creating/altering seam patterns** or Chapter 10.04 **Program management**.



- Switch on the machine, see Chapter 8.03 **Switching the machine on/off**.
- If necessary call up the programmed sewing mode. (The LED in the key must be illuminated.)

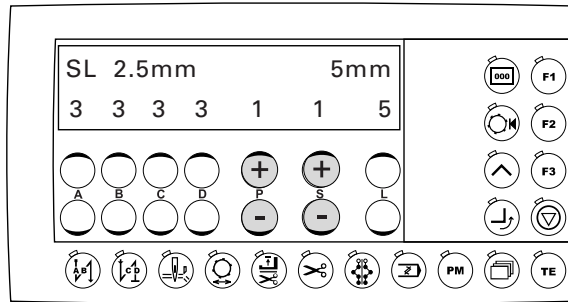

Functions in manual sewing, also see Chapter 7.04.03 **Function keys**:



Start backtacks on/off



Alter seam pattern\*



End backtacks on/off



Line selection\*



Edge trimmer on/off



Piece counter display on/off



Jig drive on/off



Support roller on/off



Sewing foot raised after thread trimming on/off



Corner programming\*



Thread trimmer on/off



Cycle time display on/off



Alternate sewing







Start inhibitor on/off

\* The function is available from mechanic level "b" on, see Chapter 12.12.01 **Selecting the user level**.

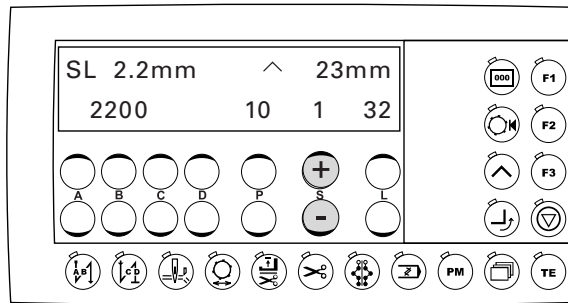



- Insert the workpiece, see Chapter 9.09 **Inserting the workpiece**.
- Select the program number of the desired seam pattern by pressing the +/- keys (P).
- Start the sequence by operating the pedal, see Chapter 7.03 **Pedal**.



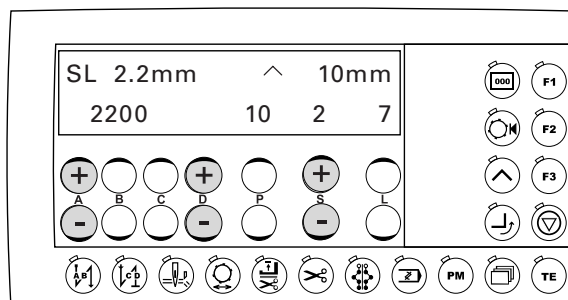

- Sew the first seam section to the first corner using the pedal function (e.g. **32** stitches).
-  ● Call up the corner programming function. (LED in the key is illuminated).
-  ● Activate the top line of the display. (LED in the key is illuminated).
- Press the +/- key (**S**) to select the desired turn (e.g. **23 mm**).
-  ● Switch on the "turn corner" function for the seam section. The turn is carried out (the turning area can be corrected by pressing the +/- key (**S**)).
-  ● Activate the bottom line of the display (LED in the key is not illuminated).
- Press the +/- key (**S**) to select the second seam section.



-  ● Activate the bottom line of the display. (LED in the key is not illuminated).
- Press the +/- key (**D**) to select the desired stitch length value (e.g. **2.2 mm**).
- Sew the second seam section using the pedal function (e.g. **7** stitches).
-  ● Activate the bottom line of the display (LED in the key is not illuminated).
- Press the +/- key (**A**) to select the desired speed (e.g. **2200**).
-  ● Call up the corner programming function. (LED in the key is illuminated).
- Press the +/- key (**S**) to select the desired turn (e.g. **10 mm**).
-  ● Switch on the "turn corner" function for the seam section. The turn is carried out.
- Press the +/- key (**A**) to select the desired speed (e.g. **2200**).
- Press the +/- key (**S**) to select the third seam section.

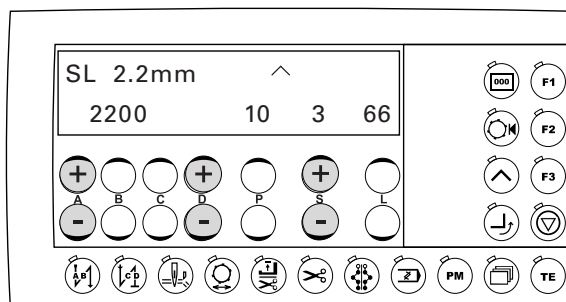

- Activate the top line of the display. (LED in the key is illuminated).
- Press the +/- key (D) to select the desired stitch length value (e.g. 2.2 mm).



- Activate the bottom line of the display (LED in the key is not illuminated).
- Sew the third seam section using the pedal function (e.g. 66 stitches).
- Press the +/- key (A) to select the desired speed (e.g. 2200).
- Press the +/- key (S) to select the fourth seam section.

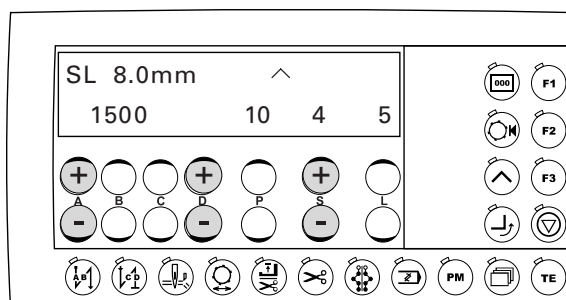

- Press the +/- key (A) to select the desired speed (e.g. 1500).
- Activate the top line of the display. (LED in the key is illuminated).
- Press the +/- key (D) to change the stitch length value (e.g. 8 mm).
- Sew the fourth seam section using the pedal function (e.g. 5 stitches).



- Activate the bottom line of the display (LED in the key is not illuminated).
- Press the +/- key (S) to select the fifth seam section.

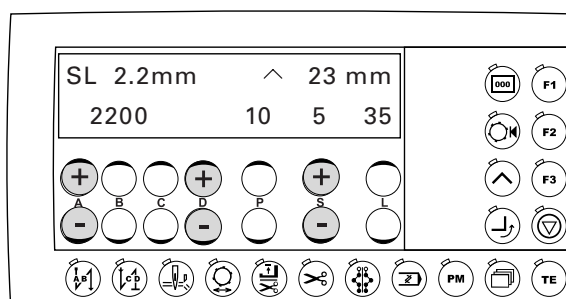



- Press the +/- key (**A**) to select the desired speed (e.g. **2200**).
- Activate the top line of the display. (LED in the key is illuminated).

- Press the +/- key (**D**) to change the stitch length value (e.g. **2.2 mm**).
- Sew the fifth seam section using the pedal function (e.g. **35** stitches).



- Call up the corner programming function. (LED in the key is illuminated).
- Press the +/- key (**S**) to select the desired turn (e.g. **23 mm**).



- Switch on the "turn corner" function for the seam section. The turn is carried out.



- Activate the bottom line of the display (LED in the key is not illuminated).



- Conclude the "teach in mode". (LED in the key is not illuminated).  
The machine starts the thread trimming function and stores the program.

- Sew a test seam and, if necessary, make corrections to the seam pattern, see Chapter **10.03.02 Altering seam patterns**.



By switching on functions such as "start backtacks/end backtacks", "edge trimmer", "thread trimmer" etc., these can be assigned to the corresponding seam pattern.



## 10.03.02 Altering seam patterns

If a seam pattern has been created in the "teach in mode", minor corrections are usually necessary. These can be made as described below.

- Switch on the machine.
- Activate mechanic level "b", see Chapter 12.12.01 **Selecting the user level.**

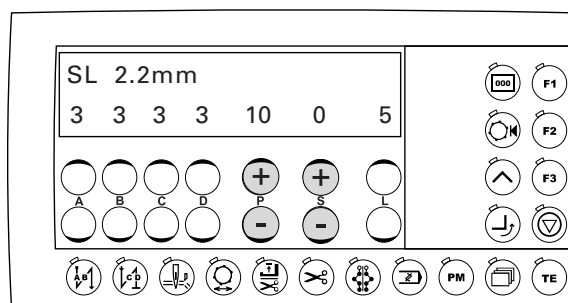

- Select the program number of the seam pattern, which is to be altered (e.g. 10), by pressing the +/- key (P).
- If necessary, alter the stitch length, see Chapter 9.06 **Entering the stitch length.**
- If necessary alter the start and end backtacks, see Chapter 9.07 **Entering the start and end backtacks.**
- Press the +/- key (S) to select the section of the seam pattern, which is to be altered (e.g. 2).

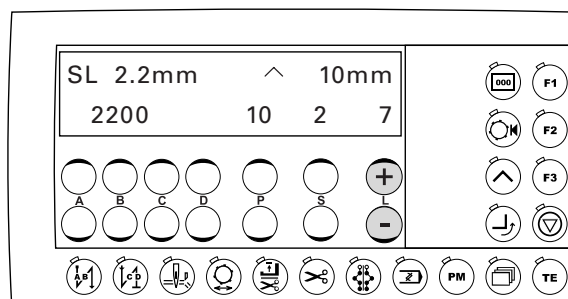

- If necessary, alter the number of stitches for the current seam section by pressing the +/- key (L).



Since each alteration affects the subsequent seam sections, these must also be corrected!

## 10.03.03 Switch on edge trimmer with delay (waistband extension)

- Switch on the machine.
- Activate mechanic level "b", see Chapter 12.12.01 **Selecting the user level.**

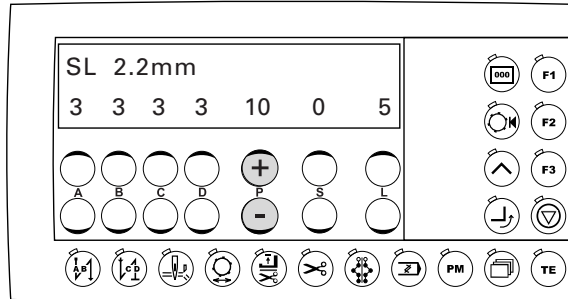

- Activate the top line of the display (LED in the key is illuminated).
- By pressing "+" the +/- key (P) call up the function
  - "PC" (piece counter),
  - "EDGE CUT" (edge trimmer),
  - "SL" (stitch length)
  - "BTM OFF (thread monitor) or
  - "Software version"

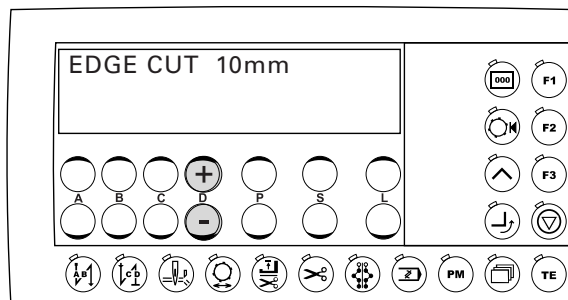

- Press the +/- key (D) to alter the number of stitches for the waistband extension.



After the appropriate function has been selected, the stitch counter can be re-set by pressing the "F3" key.

The thread monitoring method or the number of stitches can be selected with parameter "660", respectively "760", see Chapter 12.12.03 **List of parameters** or enter directly after selecting the appropriate function.

## 10.04 Program management

In program management the program numbers of the seam patterns filed in the machine memory or on the inserted SD-memory card are displayed. The programs (seam patterns) can be deleted or copied. Commercially available SD-memory cards with a storage capacity of max. 512 MB can be inserted in the control panel. The programs are filed in machine-related sub-directories. The way to insert or remove the SD-memory card is described in Chapter 9.08 **Inserting/removing the SD-memory card**. Up to 99 programs can be stored in the machine memory.

If SD-memory cards have to be formatted with the PC, they must be formatted in the format "FAT16". Alternatively the SD-memory cards can also be formatted with the formatting function of the appropriate machine, see Chapter 10.04.08 **Formatting the SD-memory card**.

### 10.04.01 Calling up the program management

- Switch on the machine.
- If necessary, call up the manual sewing mode. (LED in the key is not illuminated.)
- Press the **TE** key twice.

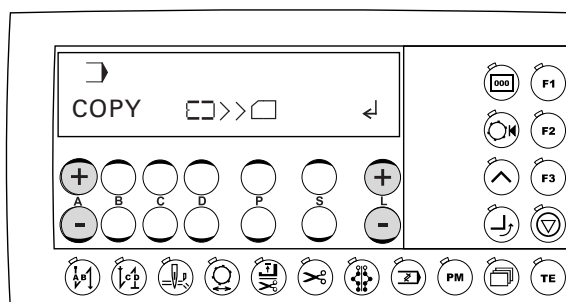

After the program management has been called, the first menu item (copying data to the SD-memory card) appears.

Confirm the selection of the menu item by pressing "+" on the +/- keys (L).

To scroll through the other menu items, press the +/- keys (A), see following chapters.

The following menu items are available in the program management:

- Display of the programs in the machine memory
- Display of the programs on the connected SD-memory card
- Copying individual programs to the SD-memory card
- Copying all programs to the SD-memory card
- Copying individual programs to the machine memory
- Copying all programs to the machine memory
- Deleting programs in the machine memory
- Deleting programs on the SD-memory card
- Formatting the SD memory card

## 10.04.02 Displaying programs in the machine memory

- Call up the program management, see Chapter 10.04.01 Calling up the program management.

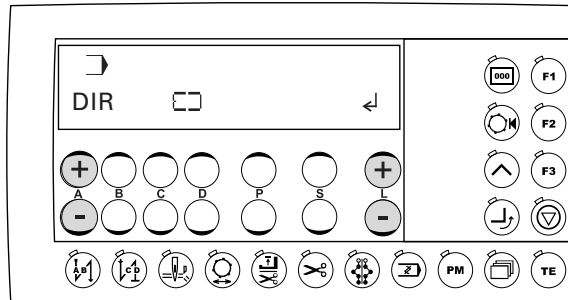

- Press the +/- keys (A) until the appropriate menu item appears.
- Confirm the selection of the menu item by pressing "+" on the +/- keys (L).

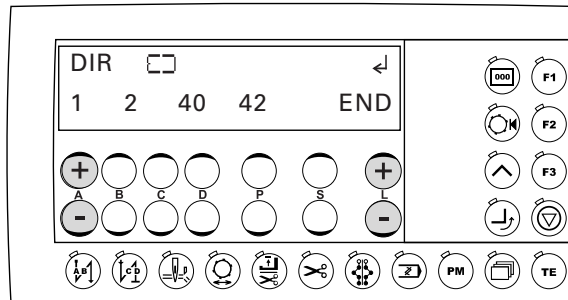

- By pressing "+" on the +/- keys (L) it is possible to scroll within the display of the machine memory (programs 1 - 99). Only assigned program spaces (existing seam patterns) are displayed.
- Press +/- keys (A) to call up the other menu items of the program management.

## 10.04.03 Displaying programs on the SD-memory card

- Call up the program management, see Chapter 10.04.01 Calling up the program management.

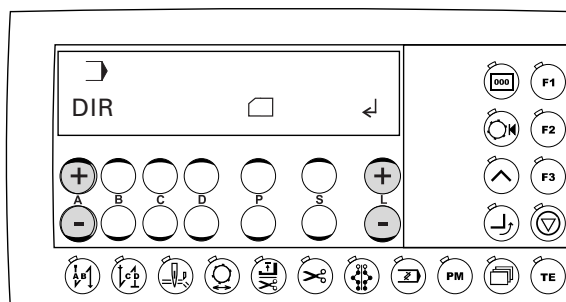

- Press the +/- keys (A) until the appropriate menu item appears.
- Confirm the selection of the menu item by pressing "+" on the +/- keys (L).

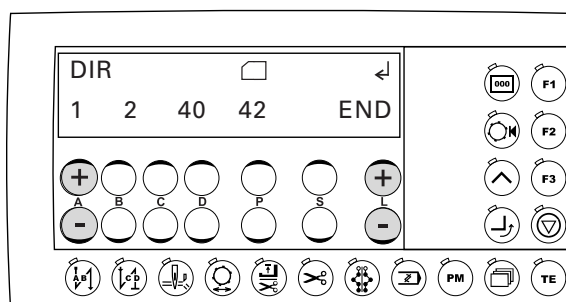

- By pressing "+" on the +/- keys (L) it is possible to scroll within the display of the SD-memory card (programs 1 - 99). Only assigned program spaces (existing seam patterns) are displayed.
- Press +/- keys (A) to call up the other menu items of the program management.

## 10.04.04 Copying individual programs to the SD-memory card

- Call up the program management, see Chapter 10.04.01 Calling up the program management.

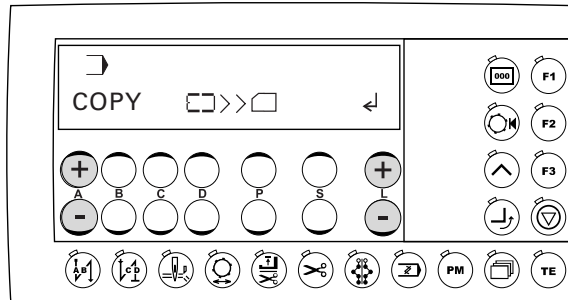

- Press the +/- keys (A) until the appropriate menu item appears.
- Confirm the selection of the menu item by pressing "+" on the +/- keys (L).

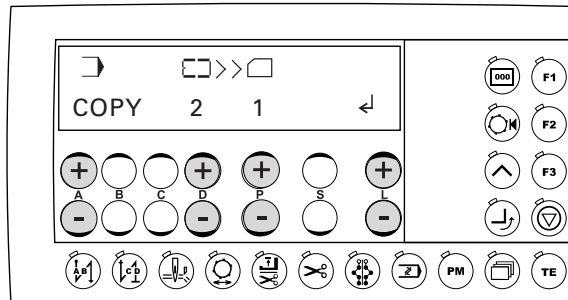

- Press the +/- keys (D) to select the programs, which are to be copied from the machine memory to the SD-memory card (programs 1 - 99).
- Press the +/- keys (P) to select the program number to be stored on the SD-memory card.
- Confirm the copying process by pressing "+" on the +/- keys (L).
- Press +/- keys (A) to call up the other menu items of the program management.



Non-assigned (active) program numbers are marked with a "?".

## 10.04.05 Copying all programs to the SD-memory card

- Call up the program management, see Chapter 10.04.01 Calling up the program management.

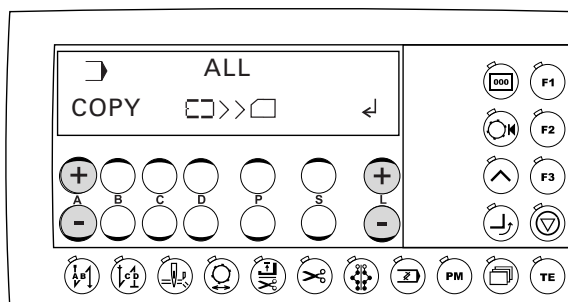

- Press the +/- keys (A) until the appropriate menu item appears.
- Confirm the selection of the menu item by pressing "+" on the +/- keys (L).

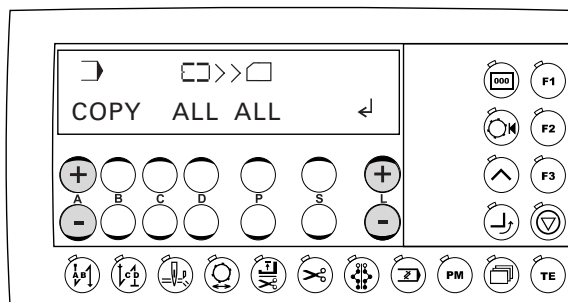

- Confirm the copying process by pressing "+" on the +/- keys (L).
- Press +/- keys (A) to call up the other menu items of the program management.

## 10.04.06 Copying individual programs to the machine memory

- Call up the program management, see Chapter 10.04.01 Calling up the program management.

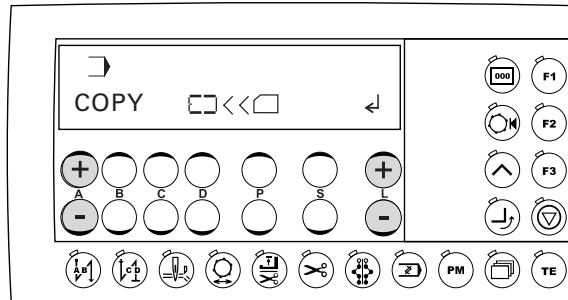

- Press the +/- keys (A) until the appropriate menu item appears.
- Confirm the selection of the menu item by pressing "+" on the +/- keys (L).

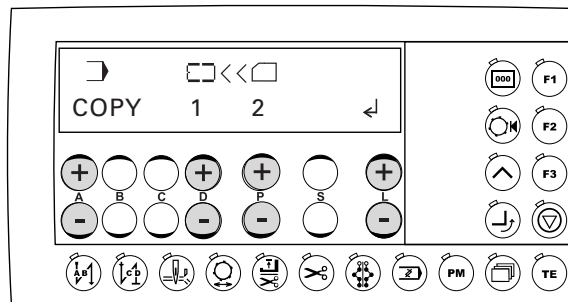

- Press the +/- keys (P) to select the programs, which are to be copied from the SD-memory card to the machine memory (programs 1 - 99).
- Press the +/- keys (D) to select the program number to be stored in the machine memory.
- Confirm the copying process by pressing "+" on the +/- keys (L).
- Press +/- keys (A) to call up the other menu items of the program management.



## 10.04.07 Copying all programs to the machine memory

- Call up the program management, see Chapter 10.04.01 Calling up the program management.

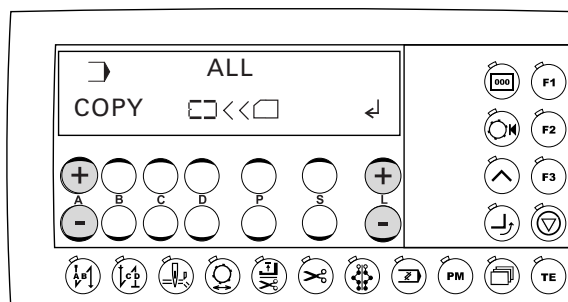

- Press the +/- keys (A) until the appropriate menu item appears.
- Confirm the selection of the menu item by pressing "+" on the +/- keys (L).

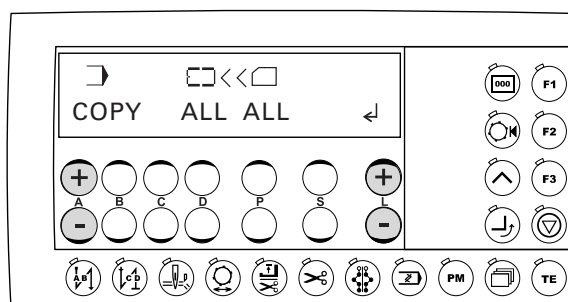

- Confirm the copying process by pressing "+" on the +/- keys (L).
- Press +/- keys (A) to call up the other menu items of the program management.

## 10.04.08 Deleting programs in the machine memory

- Call up the program management, see Chapter 10.04.01 Calling up the program management.

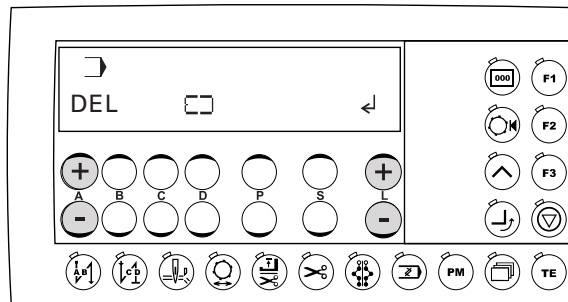

- Press the +/- keys (A) until the appropriate menu item appears.
- Confirm the selection of the menu item by pressing "+" on the +/- keys (L).

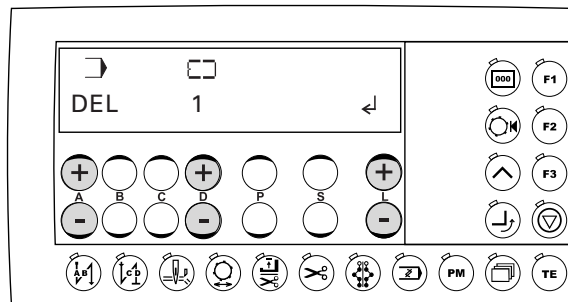

- Press the +/- keys (D) to select the programs, which are to be deleted from the machine memory (programs 1 - 99).
- Confirm the deleting process by pressing "+" on the +/- keys (L).
- Press +/- keys (A) to call up the other menu items of the program management.

## 10.04.09 Deleting programs on the SD-memory card

- Call up the program management, see Chapter 10.04.01 Calling up the program management.

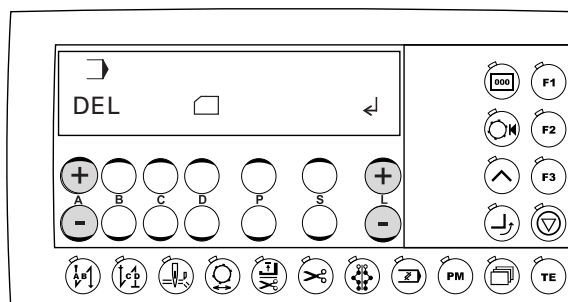

- Press the +/- keys (A) until the appropriate menu item appears.
- Confirm the selection of the menu item by pressing "+" on the +/- keys (L)..

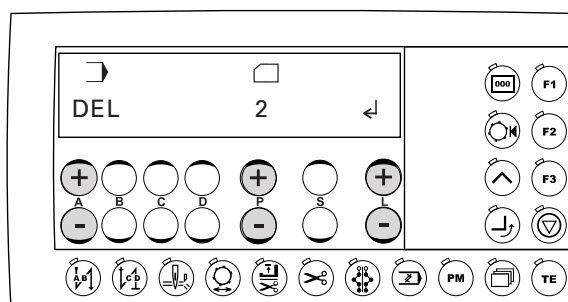

- Press the +/- keys (P) to select the programs, which are to be deleted from the SD-memory card (programs 1 - 99).
- Confirm the deleting process by pressing "+" on the +/- keys (L).
- Press +/- keys (A) to call up the other menu items of the program management.

## 10.04.10 Formatting the SD-memory card

- Call up the program management, see Chapter 10.04.01 Calling up the program management.

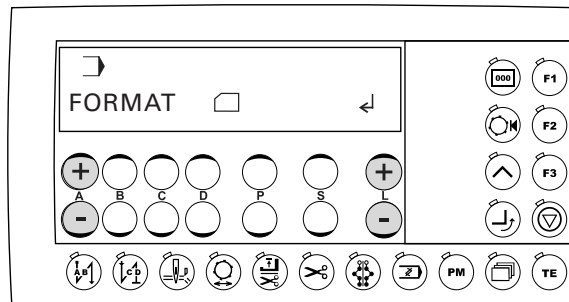

- Press the +/- keys (A) until the appropriate menu item appears.
- Confirm the selection of the menu item by pressing "+" on the +/- keys (L).



Before formatting begins a safety query is made. Press "+" on the +/- keys (L) to confirm the formatting process. The formatting process can be interrupted by pressing "-" on the +/- keys (L).

- Press +/- keys (A) to call up the other menu items of the program management.

## 10.05 Error messages

If a malfunction occurs, an error code appears on the display together with short instructions. In addition the diode in the memory card slot lights up red (see arrow). An error message may be caused by incorrect settings, defective elements or seam programs, as well as by overload conditions.

For a description of the error codes see Chapter "12.13 Description of the error codes".

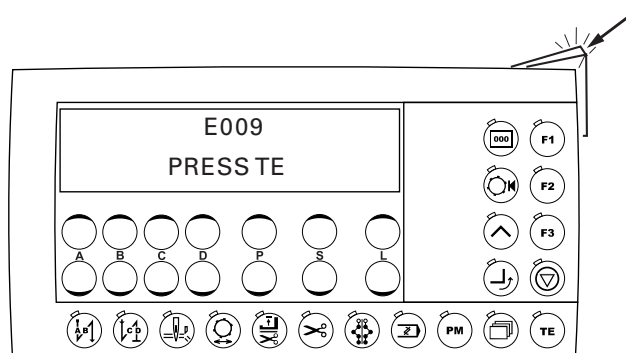

- Eliminate the error.
- Acknowledge the elimination of the error by pressing the TE-key. The diode in the memory card slot (see arrow) turns yellow again.



11 Care and maintenance

11.01 Maintenance intervals

Cleaning .....	daily, more often if in continuous operation
Checking the oil level .....	once a year
Checking/adjusting the air pressure .....	daily, before use
Cleaning the air filter of the air filter/lubricator .....	as required



During all cleaning work the machine must be disconnected from the power supply by switching off the main switch or pulling out the plug!  
 Danger of injury if the machine is started accidentally!

11.02 Cleaning the machine

The cleaning cycle required for the machine depends on following factors:

- Single or several shift operation
- Amount of dust resulting from the workpiece

It is therefore only possible to stipulate the best possible cleaning instructions for each individual case.



For all cleaning work the machine must be disconnected from the mains by switching off the on/off switch or by removing the mains plug!  
 Danger of injury if the machine suddenly starts up .

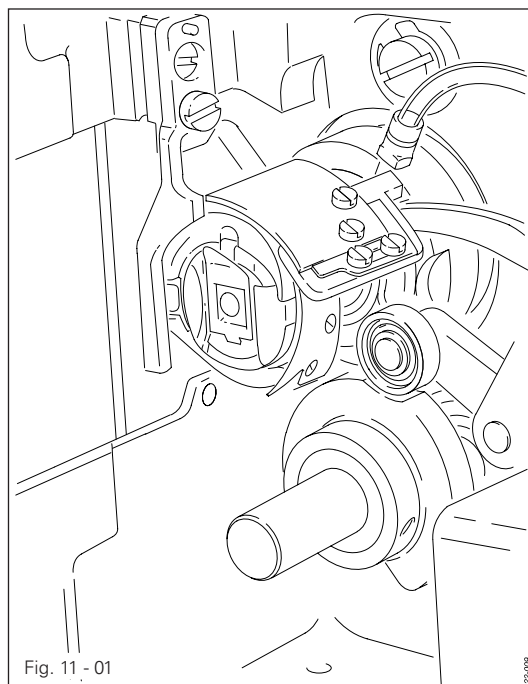

To avoid breakdowns, the following cleaning work is recommended for single shift operation:

- Swing out the cover plate and tilt back the sewing head.
- Clean the hook and hook compartment daily, more often if in continuous operation.



Return the machine to its upright position using **both** hands!  
 Danger of injury by crushing between the edge of the machine and the table top!

### 11.03 Topping up the oil tank

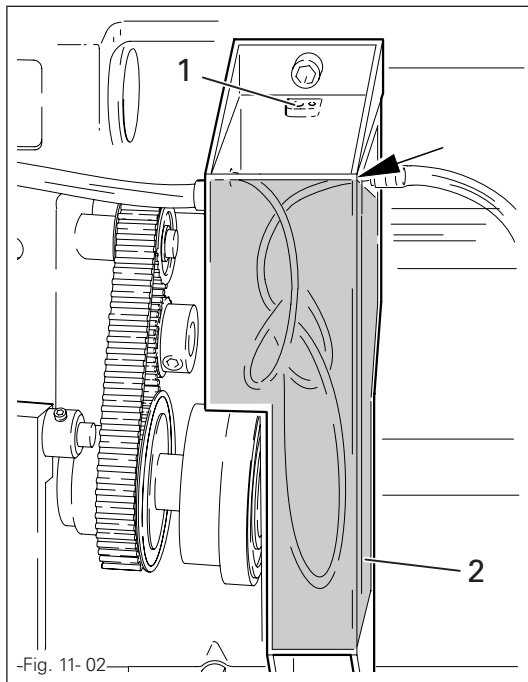

The oil reservoir must always have oil in it.

- Whenever it is necessary to refill the reservoir, tilt back the machine and let it rest on the sewing head support.
- Fill oil through hole **1** into the reservoir **2** up to the level of the front edge (see arrow).



Return the machine to its upright position using **both** hands! Danger of injury by crushing between the machine and the table top!



Only use oil with a mean viscosity of  $22.0 \text{ mm}^2/\text{s}$  at  $40^\circ\text{C}$  and a density of  $0.865 \text{ g/cm}^3$  at  $15^\circ\text{C}$ .

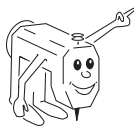

We recommend PFAFF sewing machine oil, part no. **280-1-120 144**.

### 11.04 Checking/regulating the air pressure

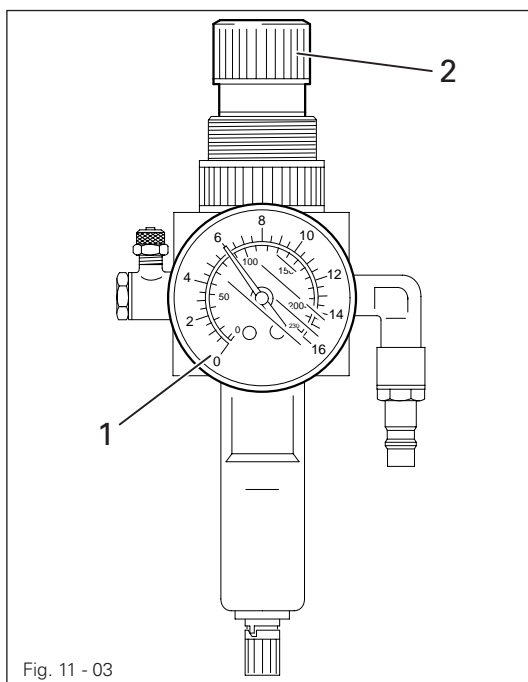

- Check the air pressure on gauge **1** every time before operation.
- Gauge **1** must show a pressure of **6 bar**.
- Regulate this pressure if required.
- To do so, pull knob **2** up and turn it accordingly..

### 11.05 Emptying/cleaning the water bowl of the air filter/regulator

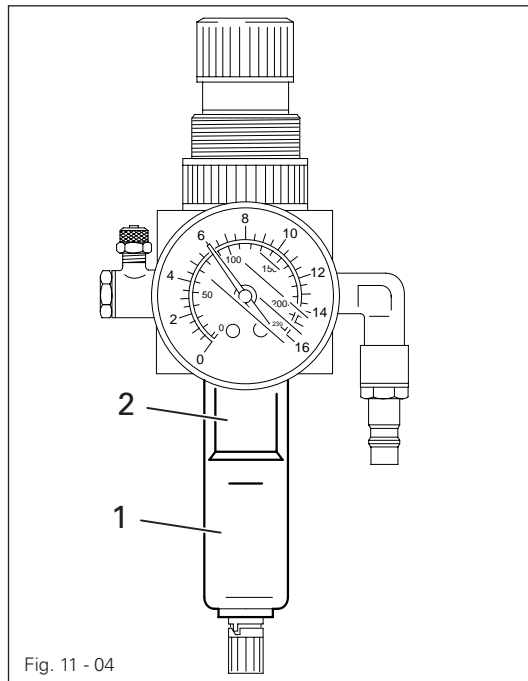

Fig. 11 - 04



Switch off the machine.  
Disconnect the air hose at the  
air filter/regulating unit.

#### Emptying the water bowl

- Water bowl 1 empties itself automatically when the air hose is disconnected from the air filter/regulator.

#### Cleaning the filter

- Unscrew water bowl 1 and take out filter 2.
- Clean the filter with compressed air or with isopropyl-alcohol, part number 95-665735-91.
- Screw in filter 2 and screw on water bowl 1

## 12 Adjustment



On the PFAFF 3511-2/01 do not use a screw clamp on the needle bar!  
The special coating of the needle bar could be damaged..

### 12.01 Notes on adjustment

All following adjustments are based on a fully assembled machine and may only be carried out by expert staff trained for this purpose.

Machine covers, which have to be removed and replaced to carry out checks and adjustments, are not mentioned in the text.

The order of the following chapters corresponds to the most logical work sequence for machines which have to be completely adjusted. If only specific individual work steps are carried out, both the preceding and following chapters must be observed.

Screws, nuts indicated in brackets ( ) are fastenings for machine parts, which must be loosened before adjustment and tightened again afterwards.



If not otherwise stated, the machine must be disconnected from the electrical power supply. Danger of injury due to unintentional starting of the machine!

### 12.02 Tools, gauges and other accessories for adjusting

- 1 set of screwdrivers with blade widths from 2 to 10 mm
- 1 set of wrenches with jaw widths from 7 to 14 mm
- 1 set of Allan keys from 1.5 to 6 mm
- 1 metal rule, (Part No. 08-880 218-00)
- 1 adjustment pin (5 mm dia.), Part No. 13-033 346-05
- Adjustment gauge, part No. 61-111 639-73
- 1 adjustment gauge for tightening the hook drive belt, Part-No. 61-111 639-76
- Sewing thread and test material

### 12.03 Abbreviations

TDC = top dead center

BDC = bottom dead center



## 12.04 Checking and adjusting aids



With the aid of blocking pin 1 (part No. 13-033346-05) and if necessary adjustment gauge 3 (part No. 61-111 639-73) the machine can be blocked in the following positions for adjustment

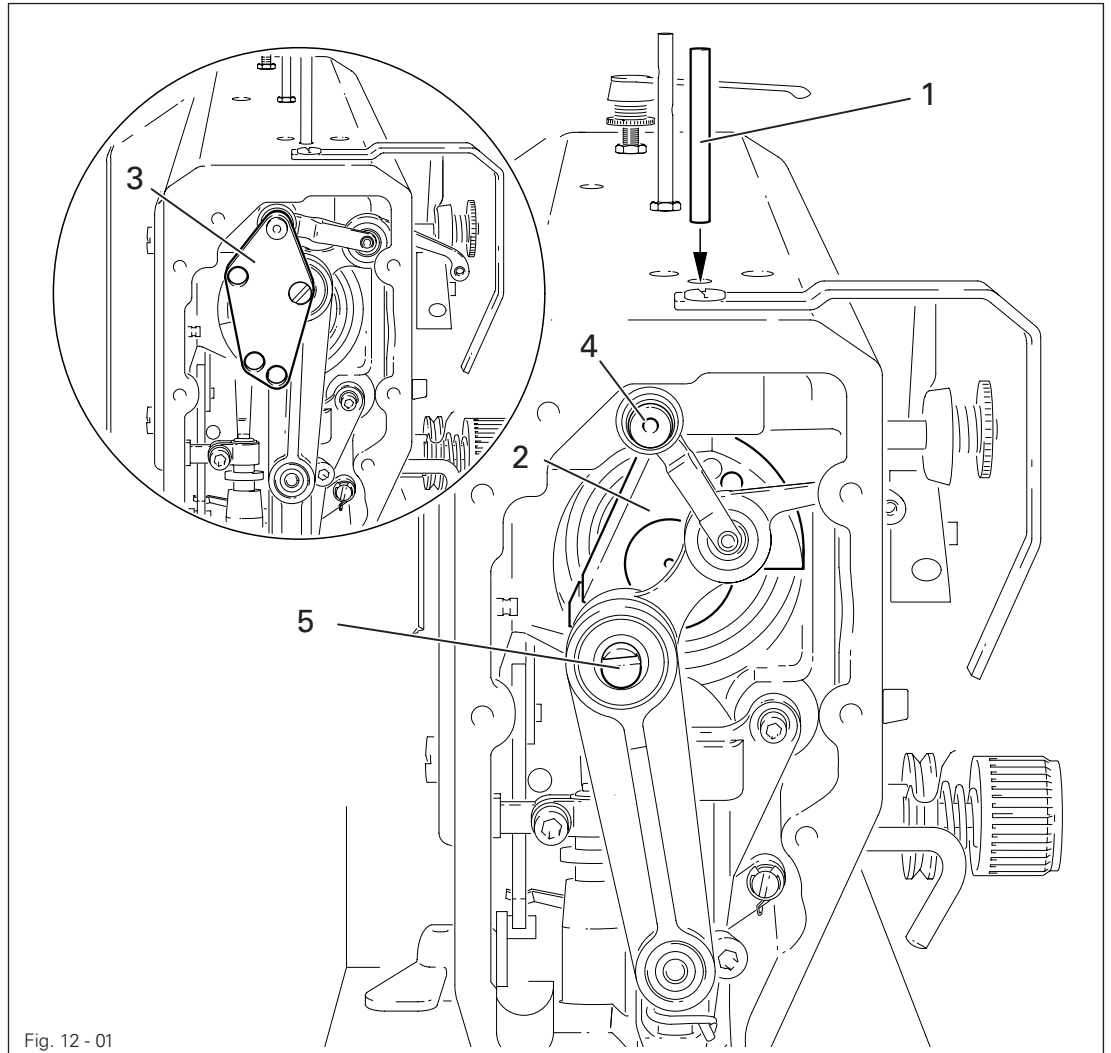
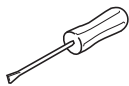

Fig. 12 - 01

**Needle bar position 1.8 mm past b.d.c.**

- Turn balance wheel until needle bar is roughly in required position
- Insert blocking pin 1 in hole
- Turn balance wheel slightly back and forth until blocking pin engages crank 2

**Needle bar position 0.6 mm past t.d.c.**

- Set needle bar roughly at required position
- Place adjustment gauge 3 onto pins 4 and 5, making sure right side is used (for 30 or 36 mm needle bar stroke)

**Needle bar position 0.6 mm past b.d.c.**

- Set needle bar roughly at required position
- Place adjustment gauge 3 onto pins 4 and 5, making sure right side is used (for 30 or 36 mm needle bar stroke)

## Adjustment

### 12.05 Adjusting the basic machine

#### 12.05.01 Basic position of the machine drive



This adjustment is only required if toothed belt 2 has been removed.

#### Requirement

When the needle bar is positioned 0,6 mm past b.d.c., the markings 3 and 4 should be in alignment..

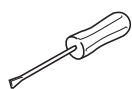
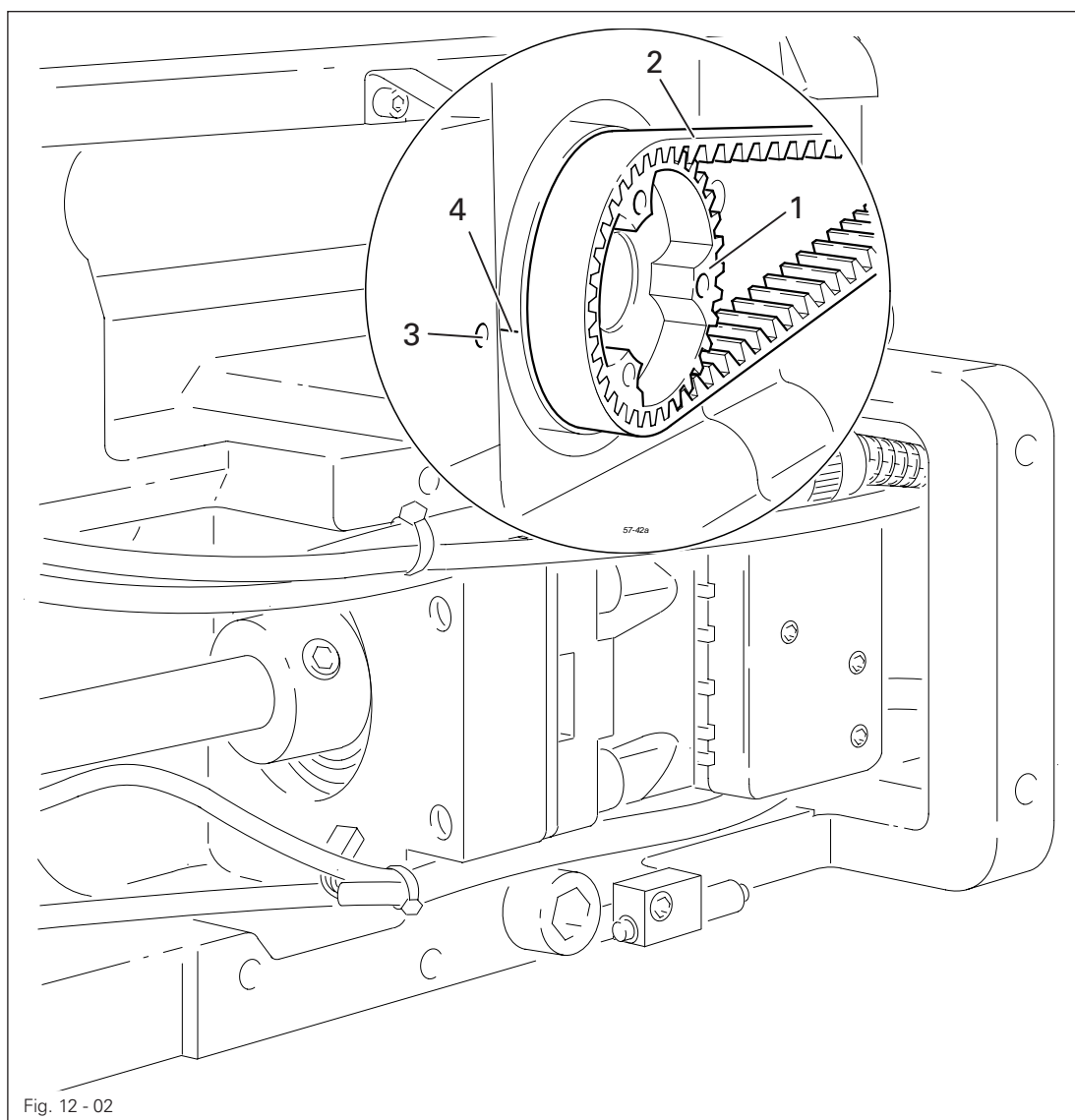

- Turn toothed belt sprocket 1 according to Requirement and push on toothed belt 2.



When installing the motor pay attention to the correct position of shaft flange, shock absorber and motor flange!

## 12.05.02 Preadjusting the needle height

### Requirement

When the needle bar is positioned at t.d.c., the needle point should be 9 mm above the needle plate.

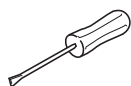
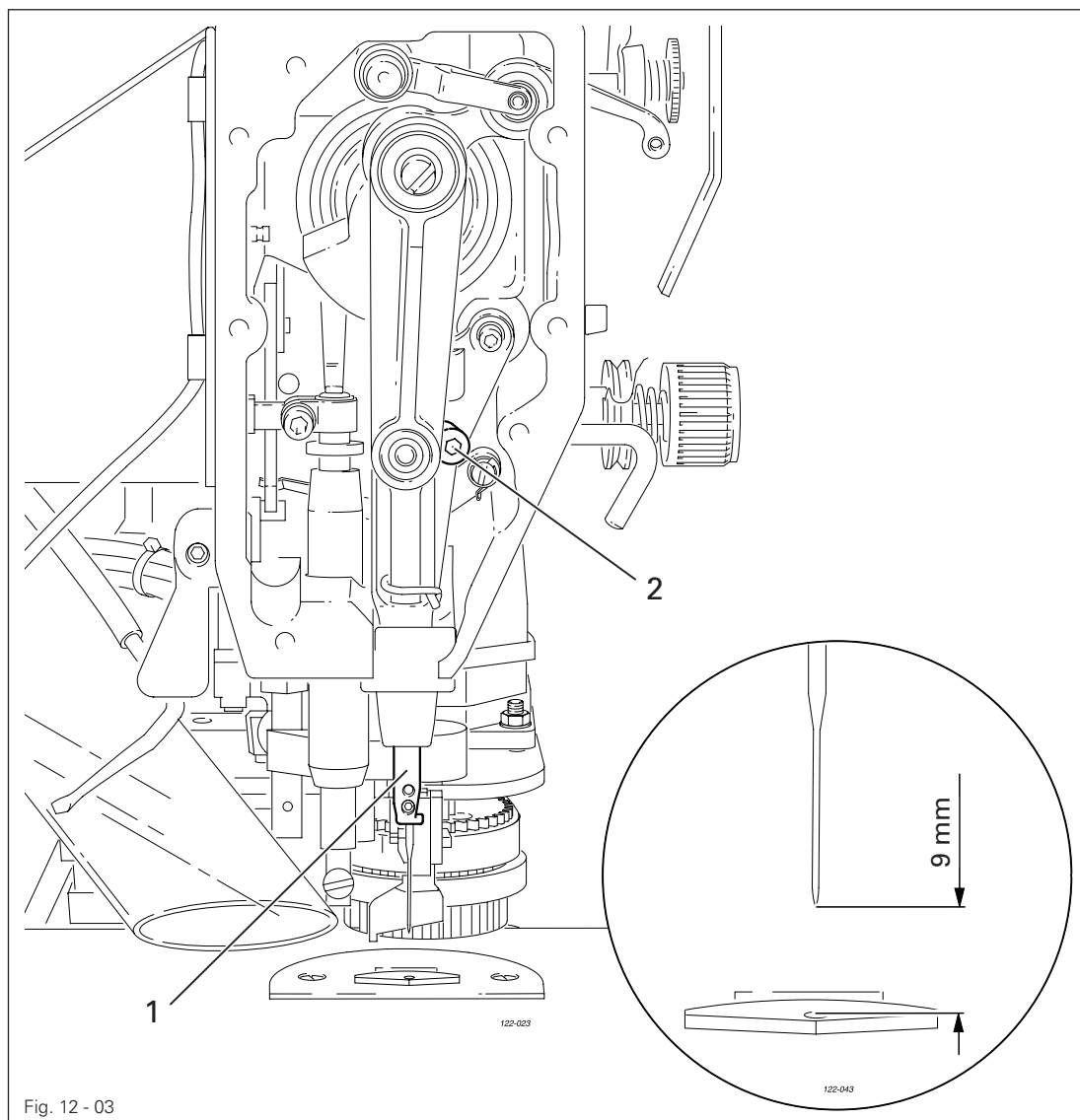

- Move needle bar 1 (screw 2), without turning it, according to the requirement.

# Adjustment

## 12.05.03 Needle in needle hole center

### Requirement

The needle must penetrate the needle hole exactly in the middle.

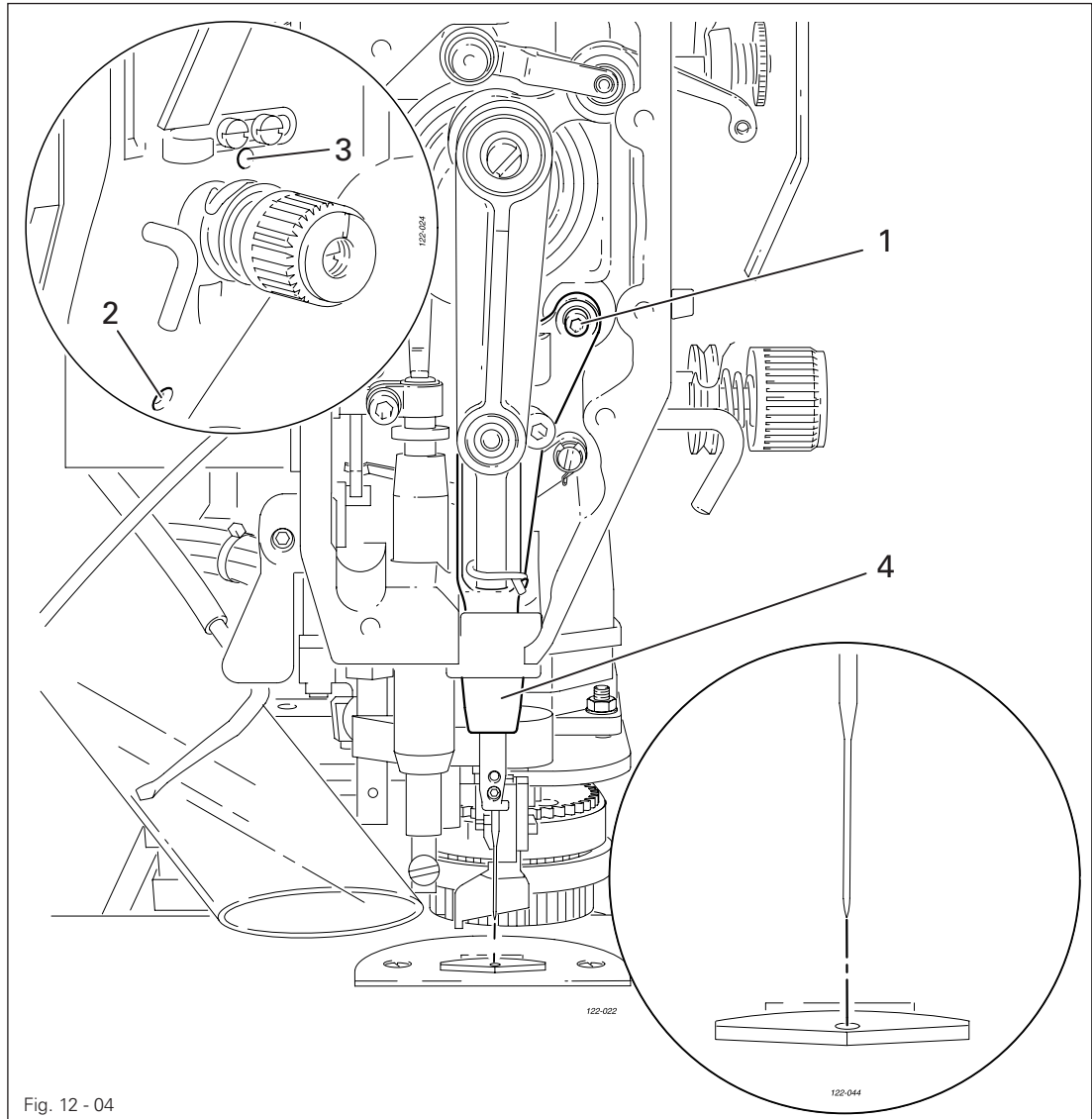
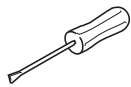

Fig. 12 - 04



- Position the needle directly above the needle hole.
- Loosen screws **1**, **2** and **3**.
- Move the needle bar frame **4** according to the requirement.
- Tighten screw **2** and turn screw **3** slightly.
- Via screw **1**, bring the retracted guide bolt to the eye of the needle bar frame **4** and tighten it.
- Turn the handwheel a few times to prevent distortion to the needle bar frame **4**.
- Tighten screw **3**.

## 12.05.04 Hook shaft bearing and toothed belt tension

**Requirement**

1. The front edge of the hook shaft **6** must be at a distance of **14.5 mm** to the needle center. At the same time, the slot in the hook shaft bearing **1** (see arrow) must be parallel to the bedplate and pointing opposite to the direction of sewing.
2. The toothed belt should be tightened in such a way that, when the gauge is pushed onto the toothed belt, the marking in the gauge window corresponds to the marking on the bushing.

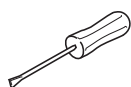
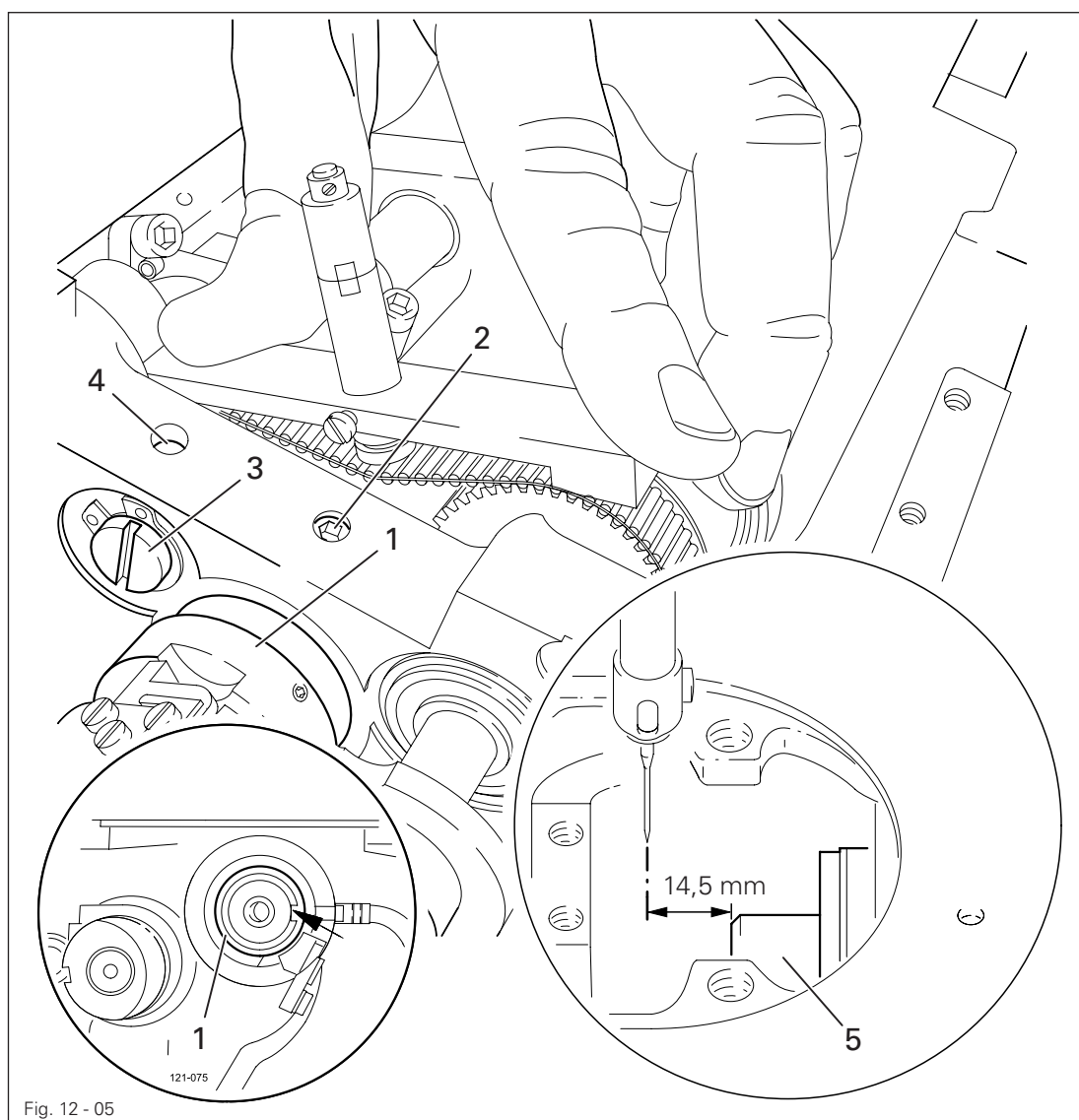

- Align hook shaft bearing **1** (screw **2**) according to **requirement 1**.
- Push the gauge (Part-No. 61-111 639-76) onto the toothed belt so that it is centred to the toothed belt and touching the bearing of the sliding shaft. The gauge window must be facing the hook.
- Eccentric **3** (screw **4**) clockwise in accordance with **requirement 2**, taking care that the axial position of eccentric **3** is not altered.

### Requirement

1. The centrifugal disk **1** must be positioned **1.5 mm** in front of the oil ring **3**.
2. When the machine is running at full speed, after approx. **10 seconds** a mark should be made by a fine stripe of oil on the strip of paper placed over the needle plate cutout.

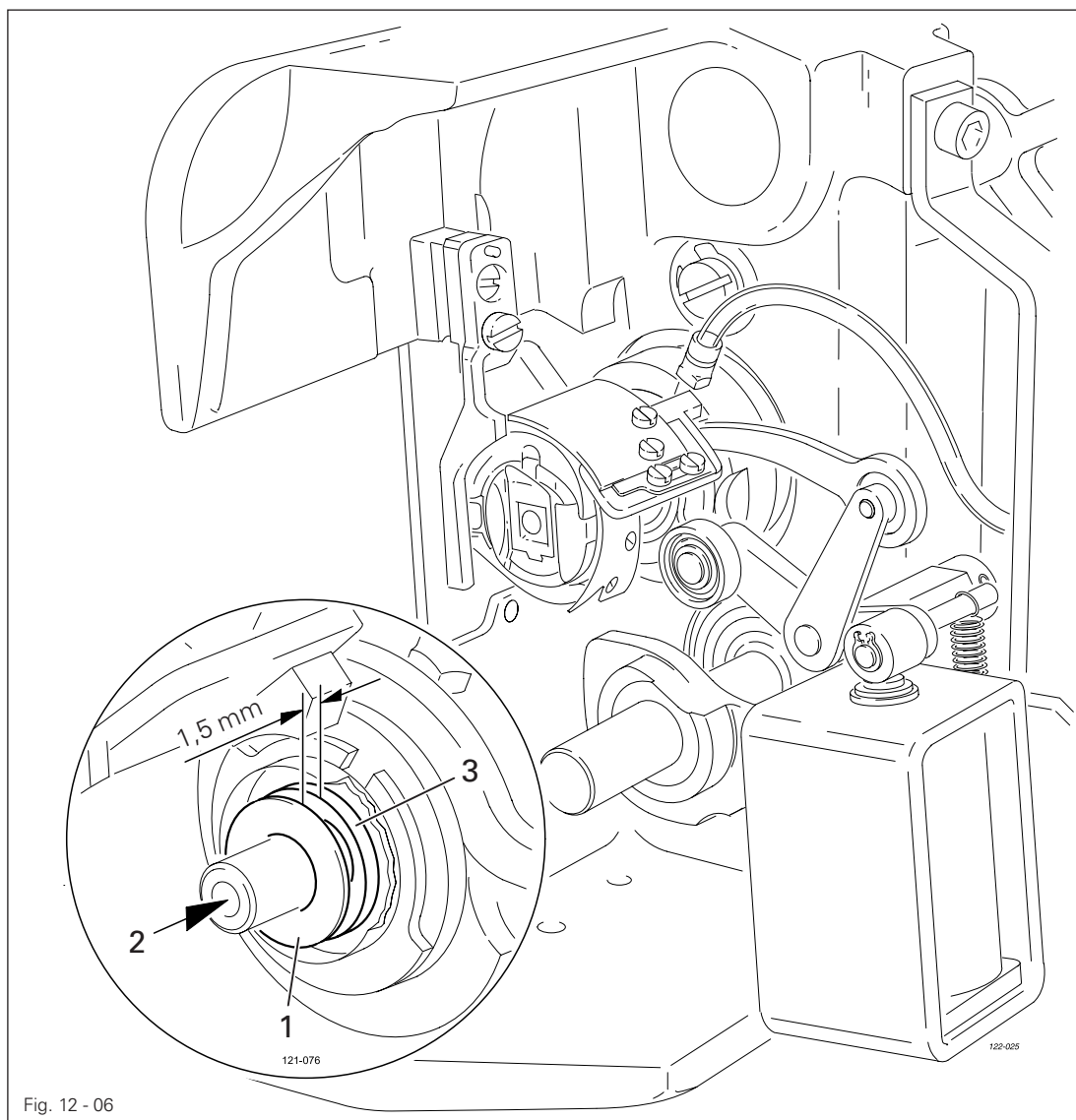

The adjustment is only necessary if the wick has been replaced.  
When replacing the wick, make sure that the new wick is impregnated with oil.

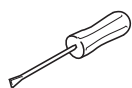

- Move the centrifugal disk **1** (screw **2**) according to requirement **1**.
- Check requirement **2**. If necessary, move centrifugal disk **1**.

12.05.06 Needle rise, hook-to-needle clearance, needle height and bobbin case position on finger

**Requirement**

With the needle at **1.8 mm** after BDC,

1. the hook point **6** must point to the middle of the needle and be at a distance of **0.05 mm - 0.1 mm** to the clearance cut of the needle, and
2. the top edge of the needle eye must be **0.8 mm** below the hook point.
3. Between the projection of the bobbin case position finger **4** and the bottom of the retaining groove there should be a distance of **0.5 mm**.

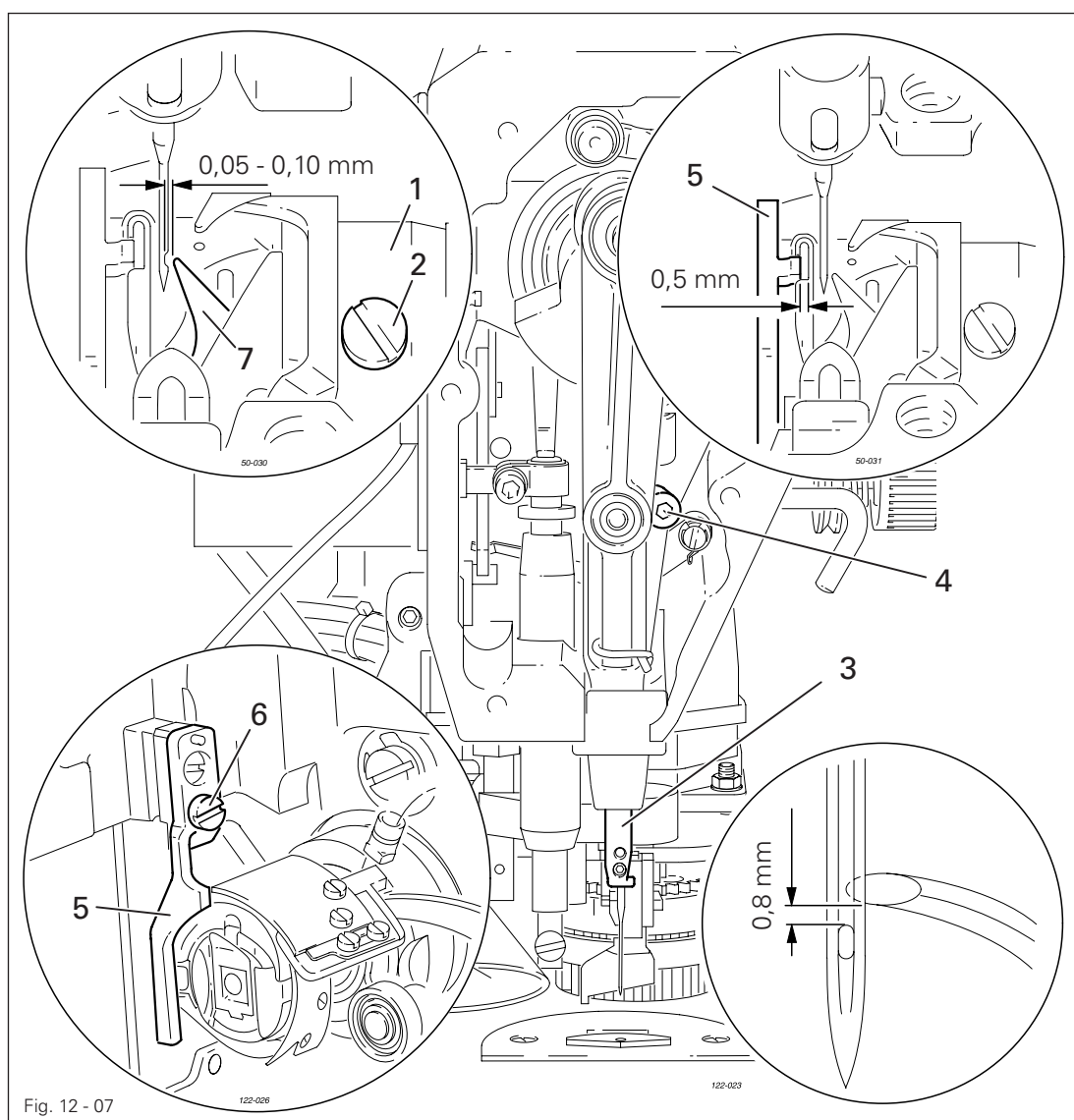
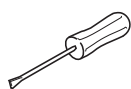

Fig. 12 - 07



- Using the adjustment pin, position the needle bar at **1.8 mm** after BDC.
- Adjust hook **1** (screws **2**) in accordance with **requirement 1**.
- Tighten screw **1**.
- Move needle bar **2** (screw **3**) without turning it according to **requirement 2**.
- Align bobbin case position finger **4** (screw **5**) according to **requirement 3**.

## 12.05.07 Thread check spring and slack thread regulator

### Requirement

1. The motion of the thread check spring must be completed when the needle point enters the material (spring stroke approx. **7 mm**).
2. When the thread loop is at its largest when going around the hook, the thread check spring must have moved by approx. **1 mm**.

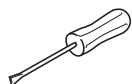
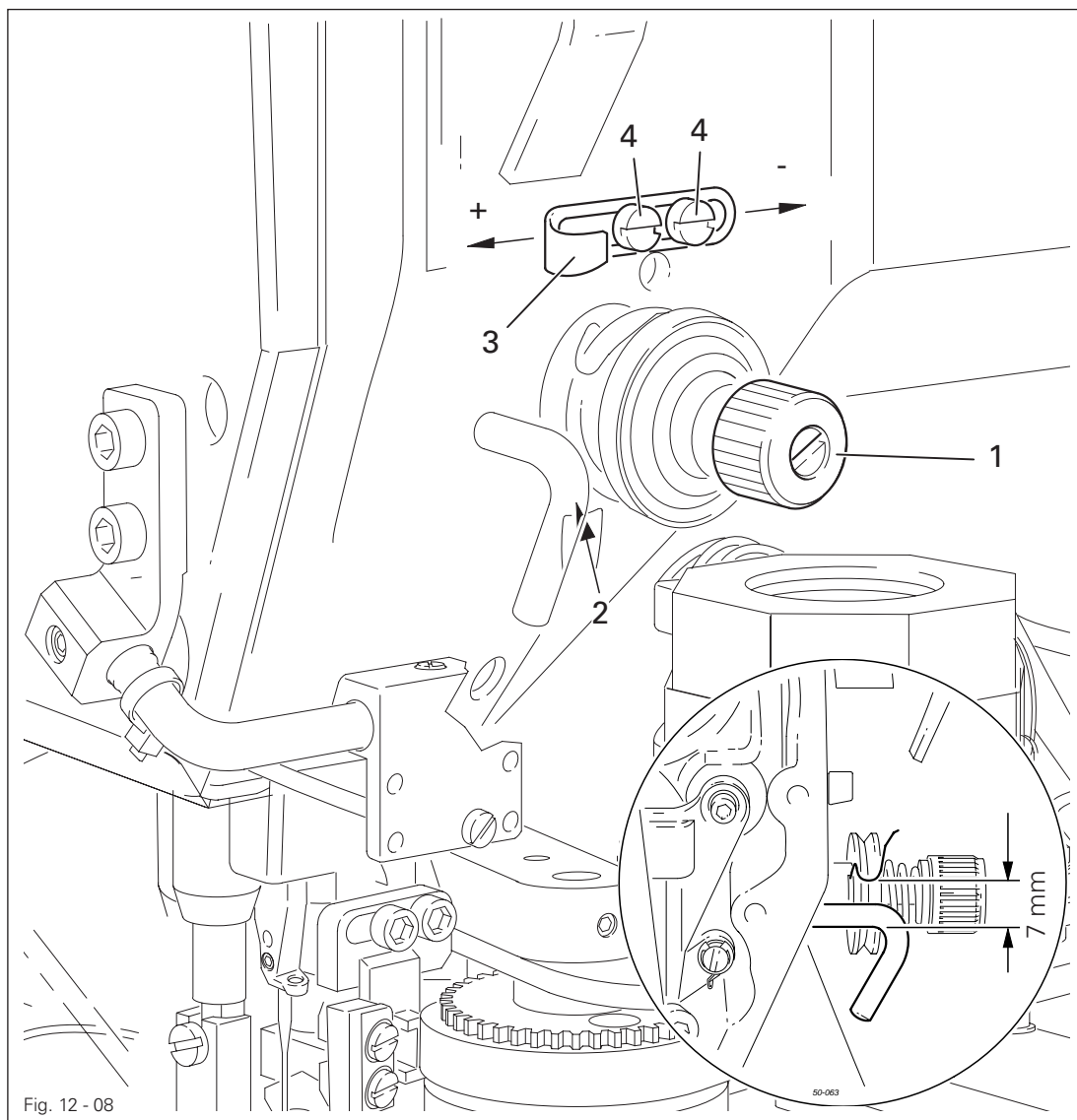

- Turn thread tension **1** (screw **2**) according to **requirement 1**.
- Turn thread tension **3** (screw **4**) according to **requirement 2**.



Due to technical sewing reasons it may be necessary to deviate from the spring stroke indicated above.

Move the slack thread regulator **3** (screw **4**) toward the "+" (= more thread) or toward the "-" (= less thread)



## 12.05.08 Bobbin winder

**Requirement**

1. With the bobbin winder on, the drive wheel **1** must engage reliably.
2. With the bobbin winder off, the friction wheel **5** must not be driven by the drive wheel **1**.
3. The bobbin winder must turn off automatically when the thread level is approx. **1 mm** from the edge of the bobbin.

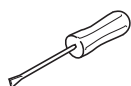
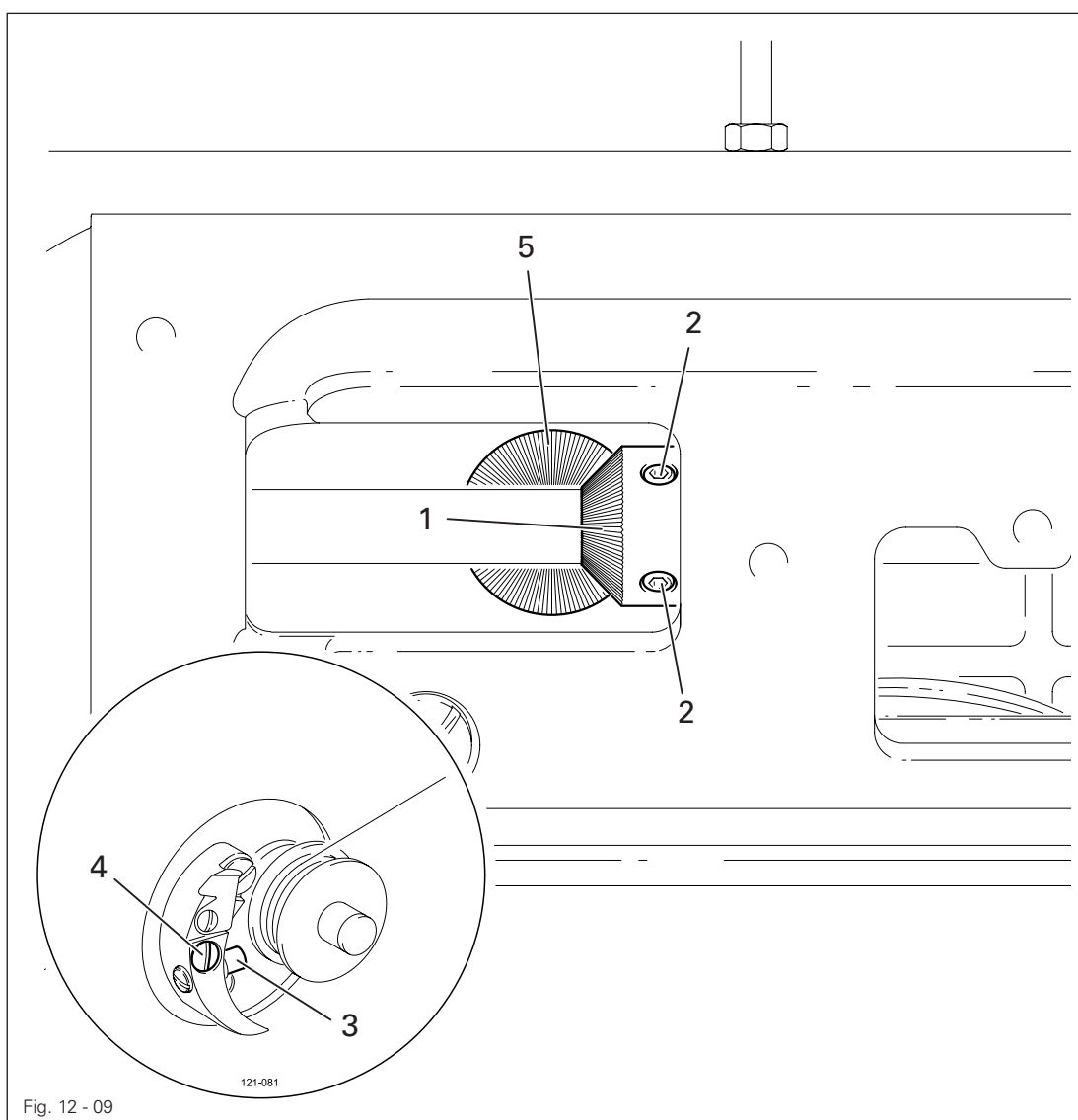

- Move drive wheel **1** (screws **2**) in accordance with **requirement 1** and **2**.
- Move bolt **3** (screw **4**) in accordance with **requirement 3**.

# Adjustment

## 12.05.09 Presser foot pressure

### Requirement

1. The sewing jig should be transported reliably.
2. The presser foot pressure should be as low as possible.

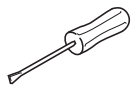
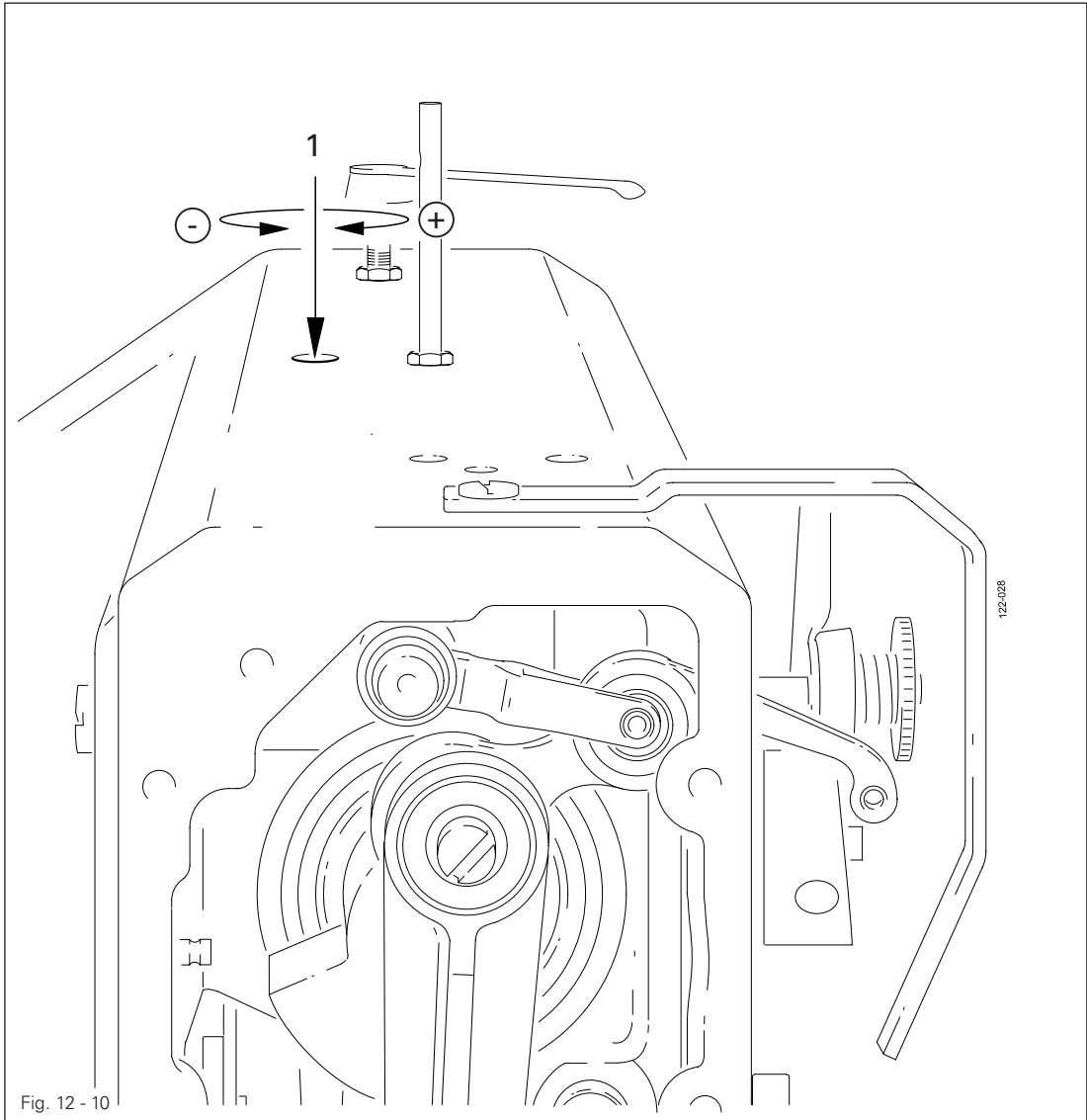

- Turn screw 1 in accordance with the requirement.

## 12.06 Adjusting the edge trimmer

### 12.06.01 Zero position of the knife

#### Requirement

When the edge trimmer is switched off

1. Lever **5** should be slightly supported (without play) and
2. The knife should not move when the balance wheel is turned.

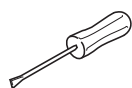
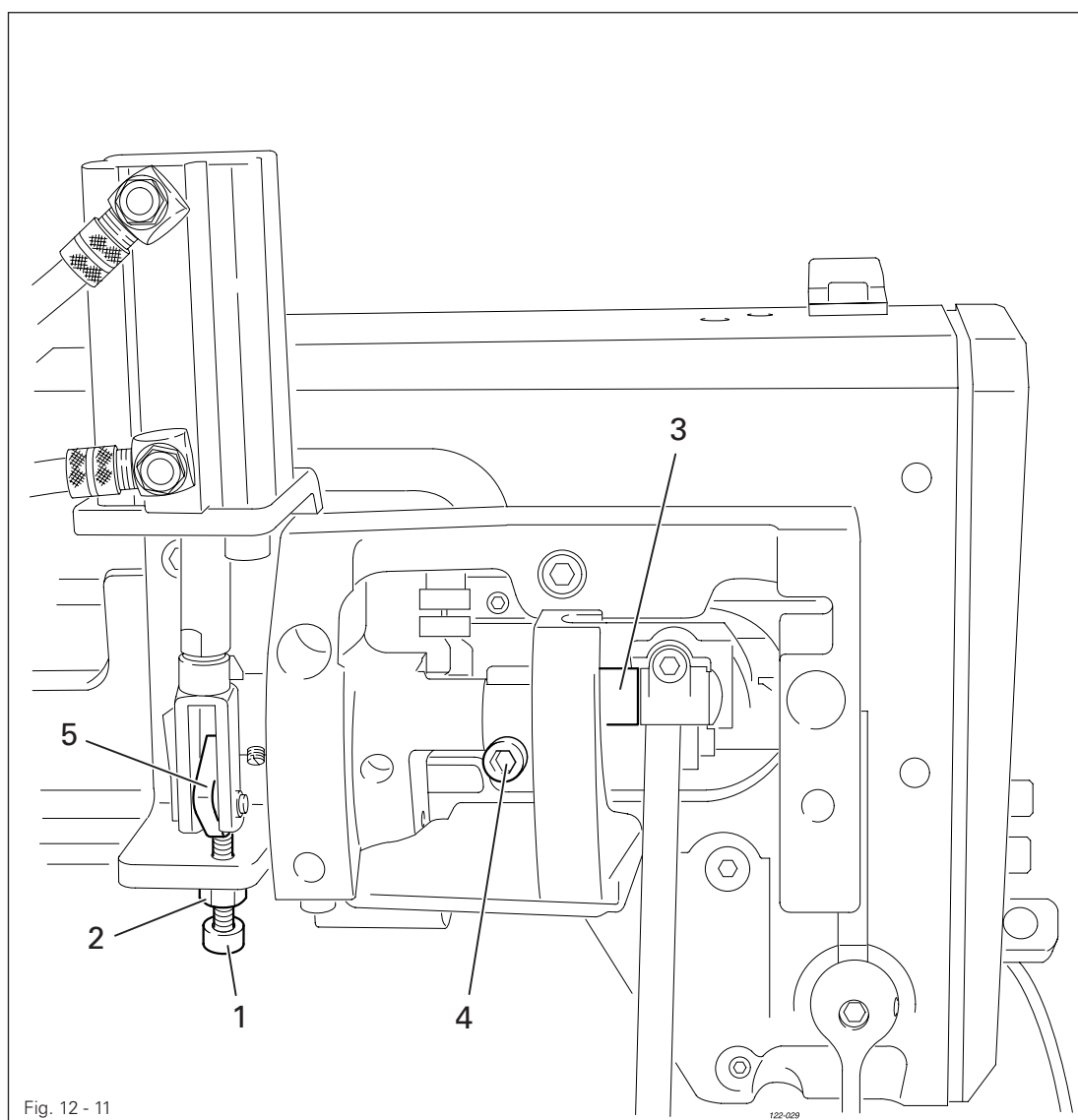

- Adjust screw **1** (nut **2**) in accordance with requirement 1.
- Adjust slotted lever **3** (screws **4**) in accordance with requirement 2.

# Adjustment

## 12.06.02 Cutting motion

### Requirement

When the edge trimmer is switched on, the knife should be at the bottom of its stroke when the needle bar is at b.d.c.

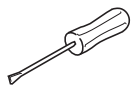
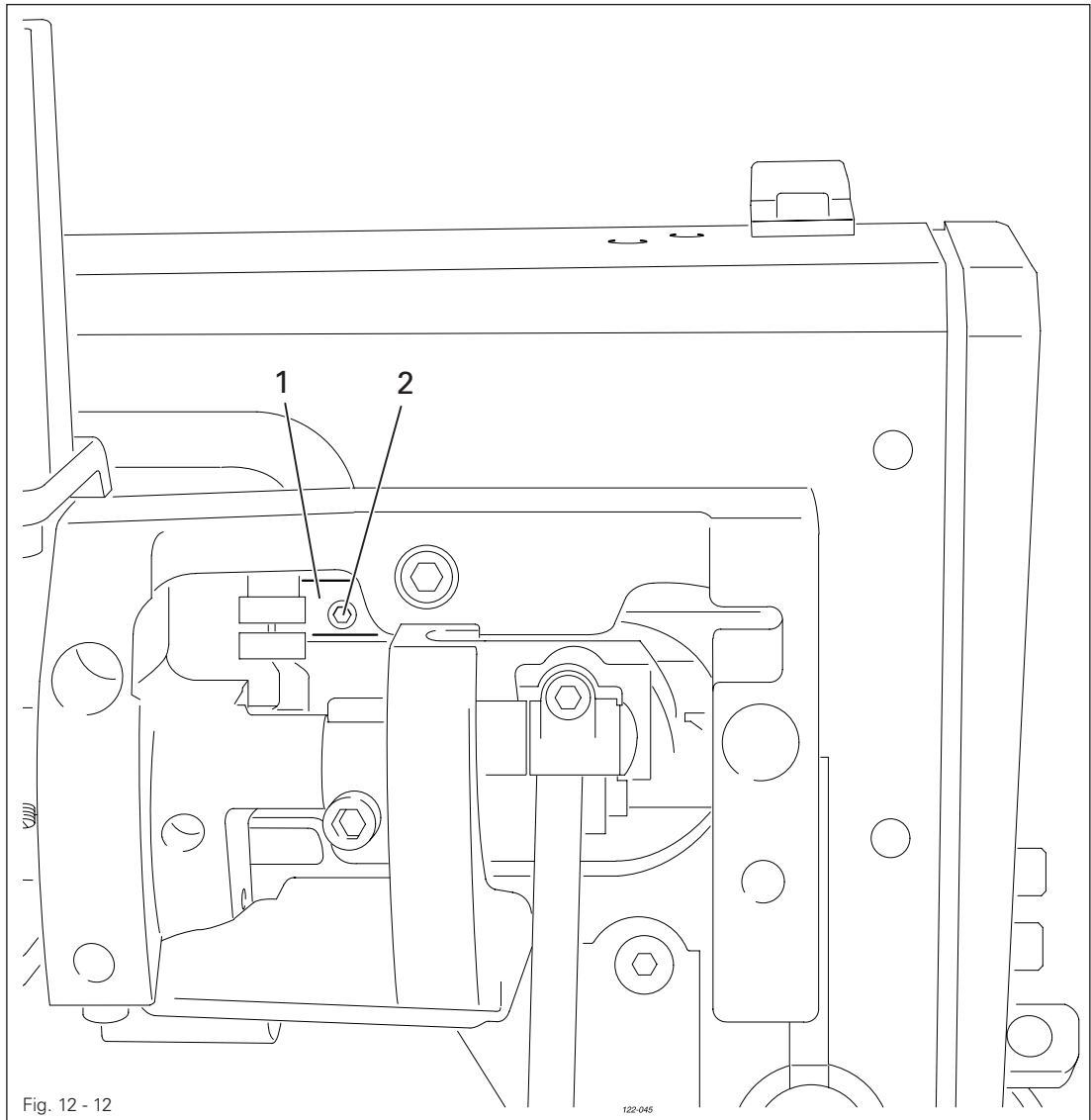

- Adjust eccentric 1 (two screws 2) in accordance with the requirement.

## 12.06.03 Knife height

### Requirement

When the knife is at the bottom of its stroke, the front edge of the knife blade should be approx. **0.5 mm** below the top edge of the stationary knife.

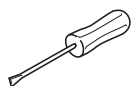
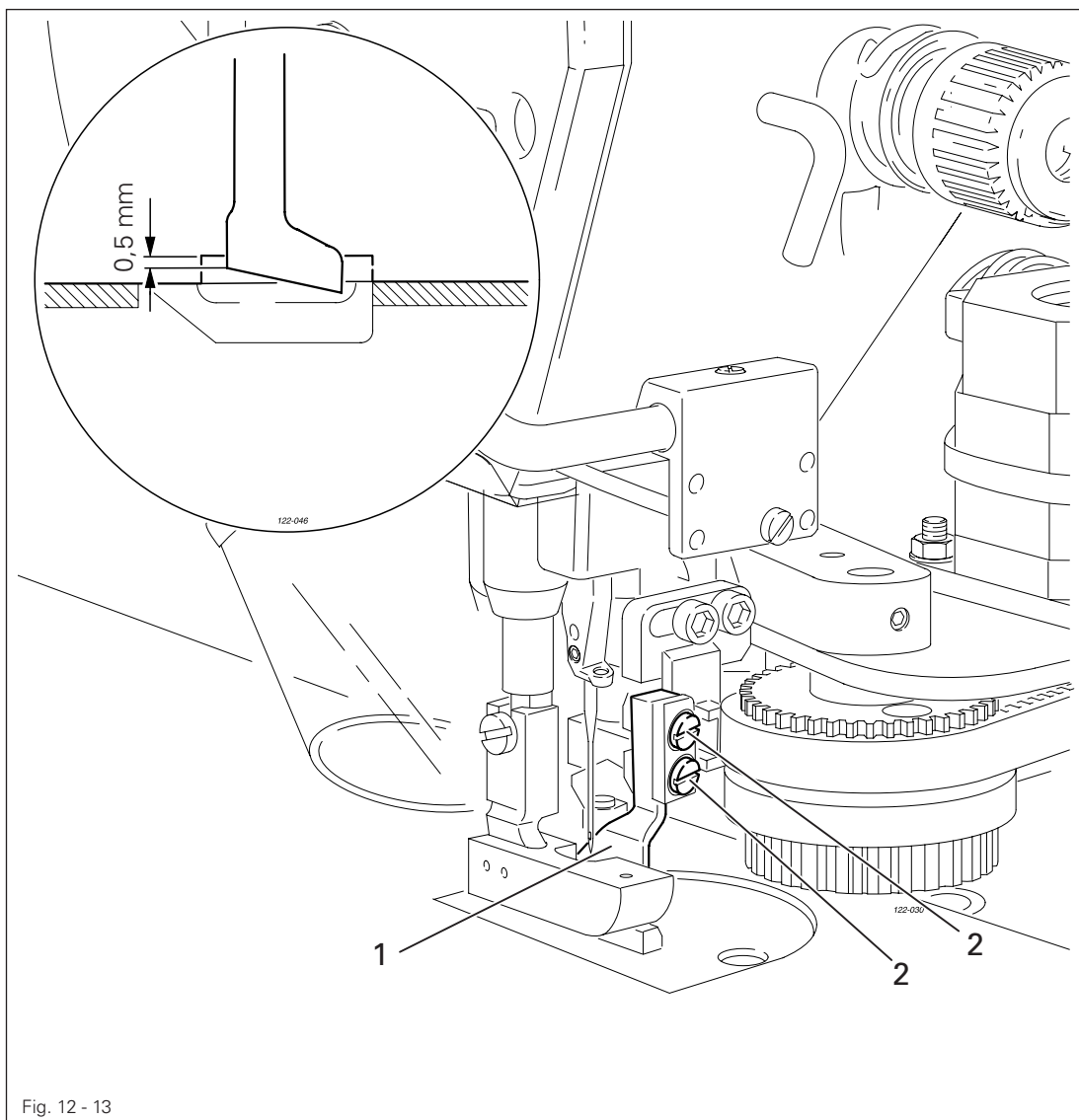

- Adjust knife 1 (screws 2) according to the requirement.

## Adjustment

### 12.06.04 Knife position in sewing direction

#### Requirement

When the needle bar is at b.d.c., the knife blade should be at a distance of 1 mm from the edge of the stationary knife.

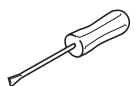
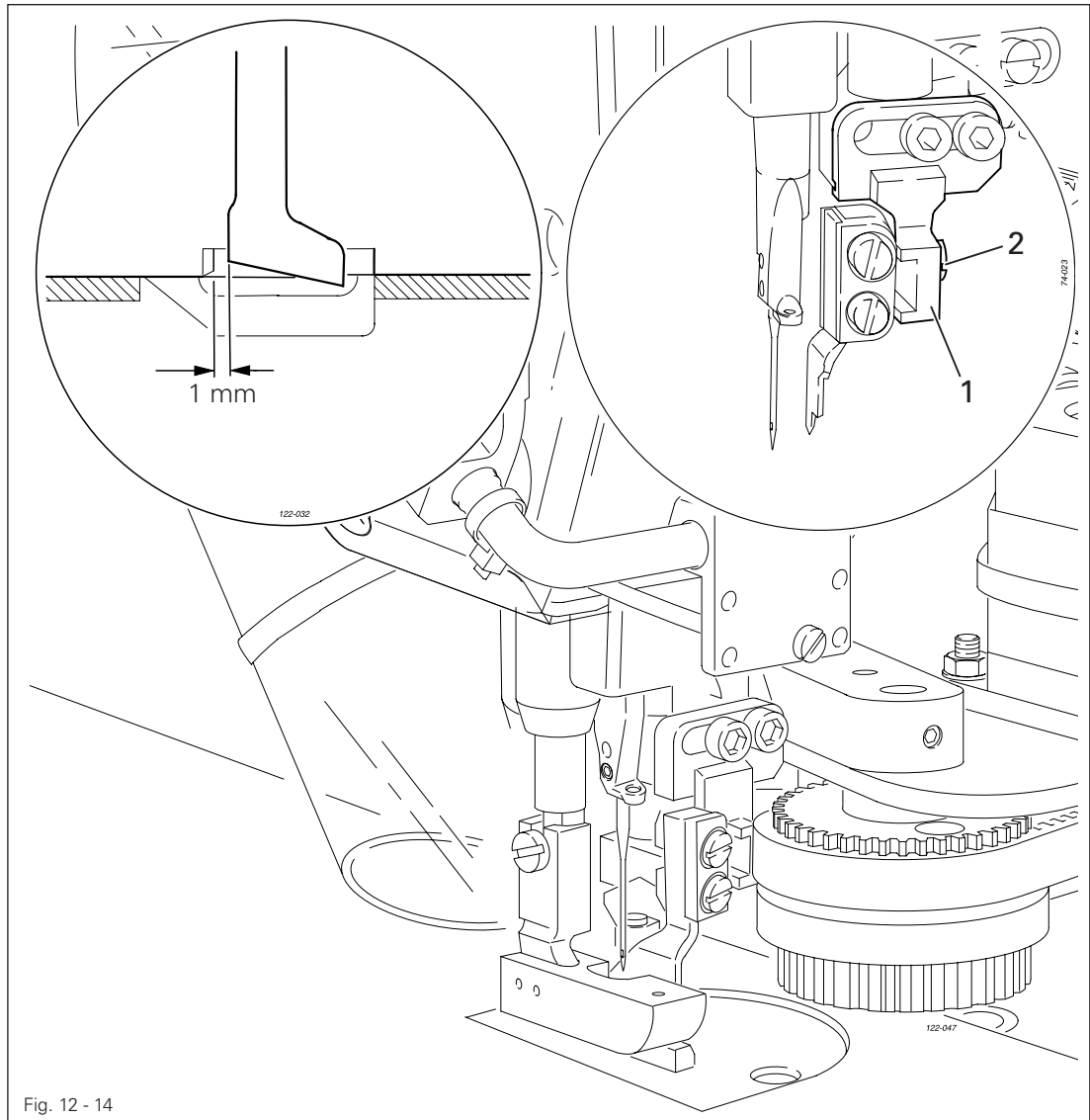

- Adjust knife bracket 1 (screw 2) according to the requirement.

## 12.06.05 Cutting angle of the knife

**Requirement**

The knife should be

1. Touching the stationary knife 6 without counter pressure and
2. Be at a 0.1 mm slant to the stationary knife 6.

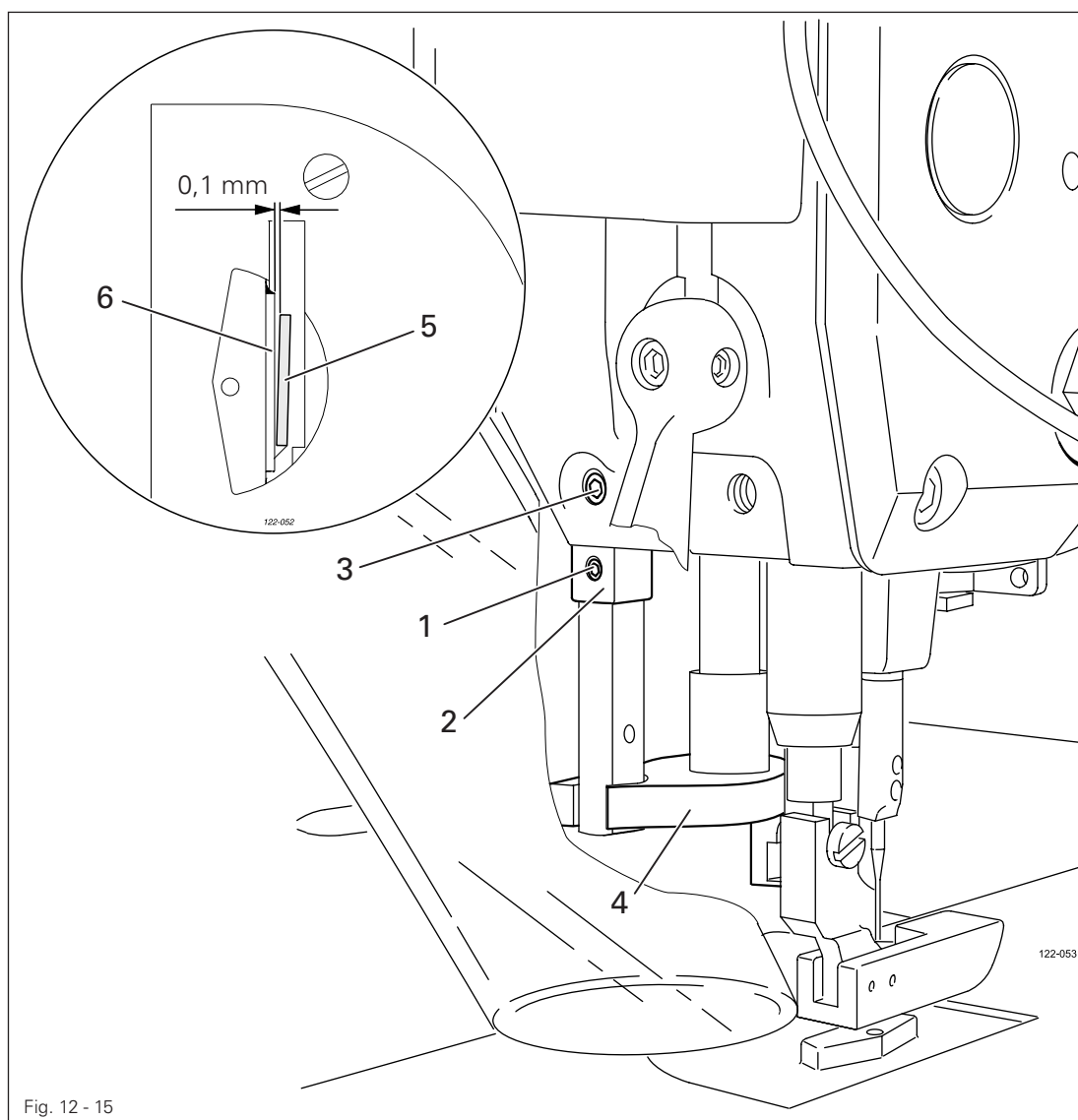
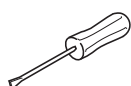

Fig. 12 - 15



- Loosen screws 1.
- Adjust eccentric 2 (screw 3) in accordance with the requirements.
- Tighten screws 1.



Make sure that knife guide 4 is moving smoothly!

## Adjustment

### 12.06.06 Knife position crosswise to sewing direction

#### Requirement

The knife should be resting on the stationary knife with light pressure.

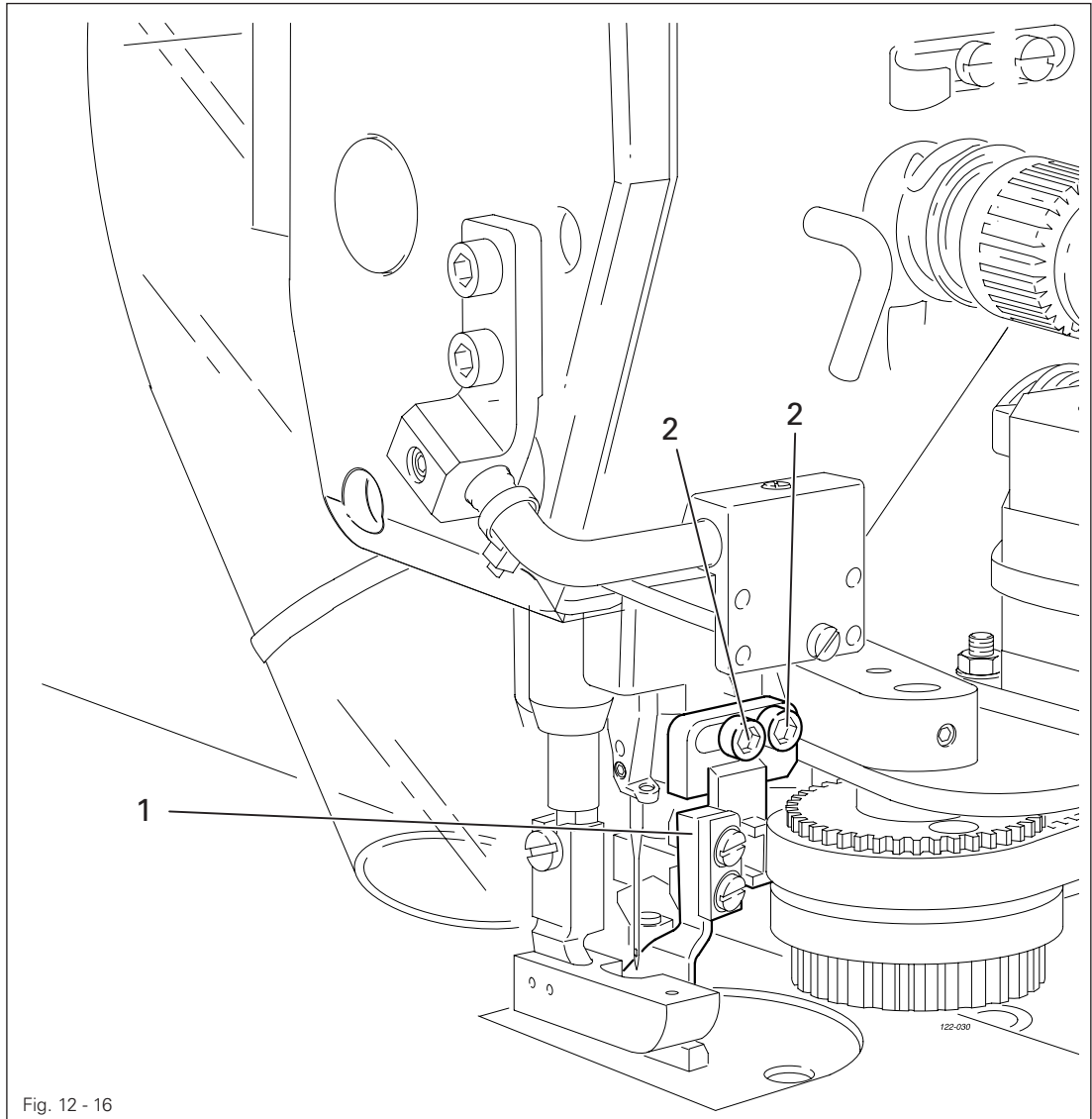
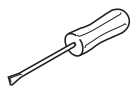

Fig. 12 - 16



- Adjust knife bracket 1 (screw 2) according to the requirement.



## 12.07 Adjusting the thread trimming device

## 13.0.01 Adjusting the solenoid / preliminary adjustment of the control cam

**Requirement**

1. When solenoid **3** is completely extended, roller lever **4** should be at the lowest point of the control cam.
2. When the needle bar is positioned at 1.8 mm after b.d.c. (needle rise position), roller lever **4** should engage in the appropriate recess of the control cam.

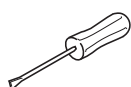
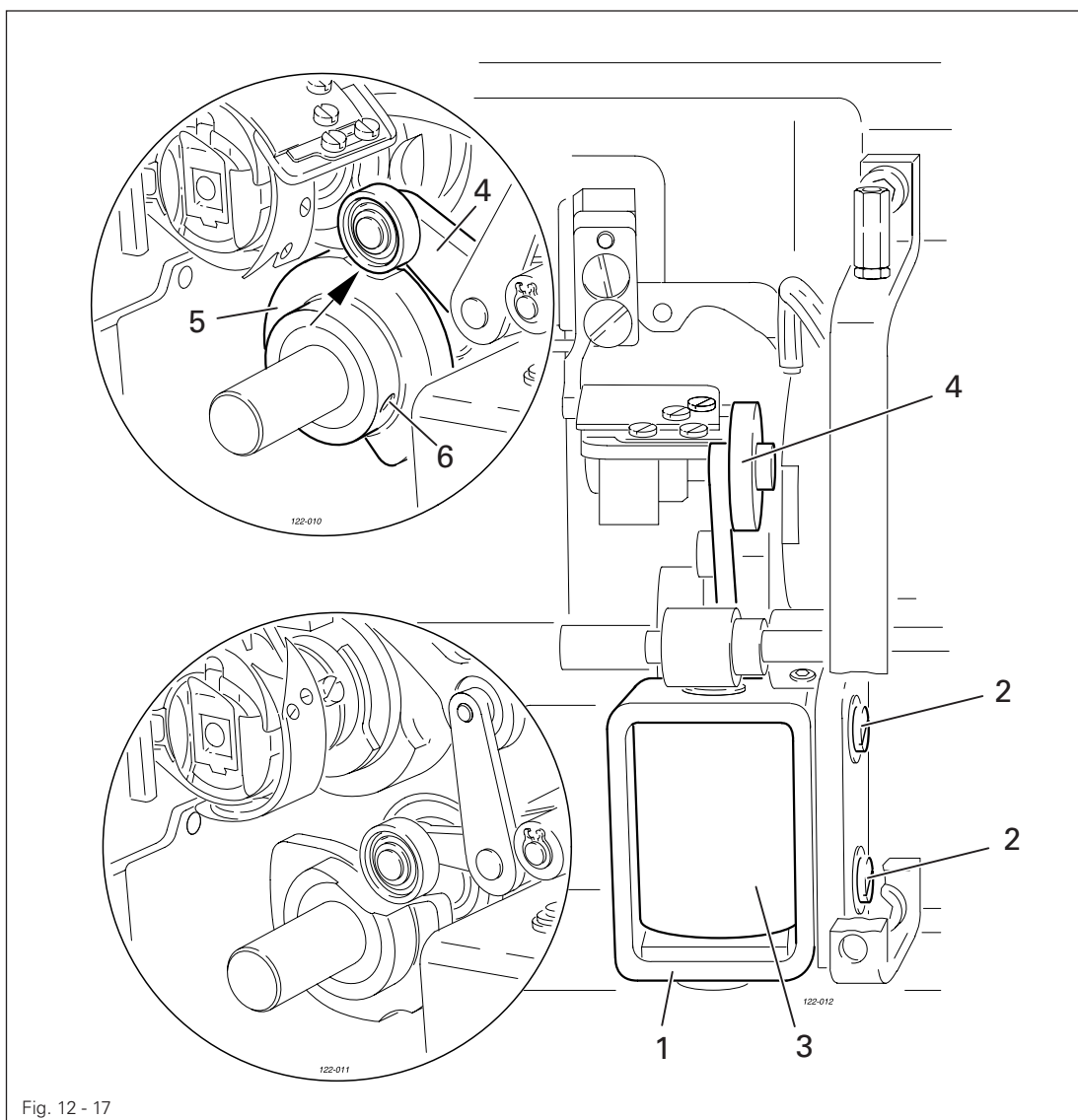

- Adjust solenoid holder **1** (screws **2**) in accordance with requirement 1.
- Adjust control cam **5** (screws **6**) in accordance with requirement 2.

## 12.07.02 Lateral alignment of the thread catcher

### Requirement

1. The tip of the thread catcher **5** must point exactly to the center of the needle.
2. The thread catcher **5** must be horizontal. It must not graze anything when it is operating.

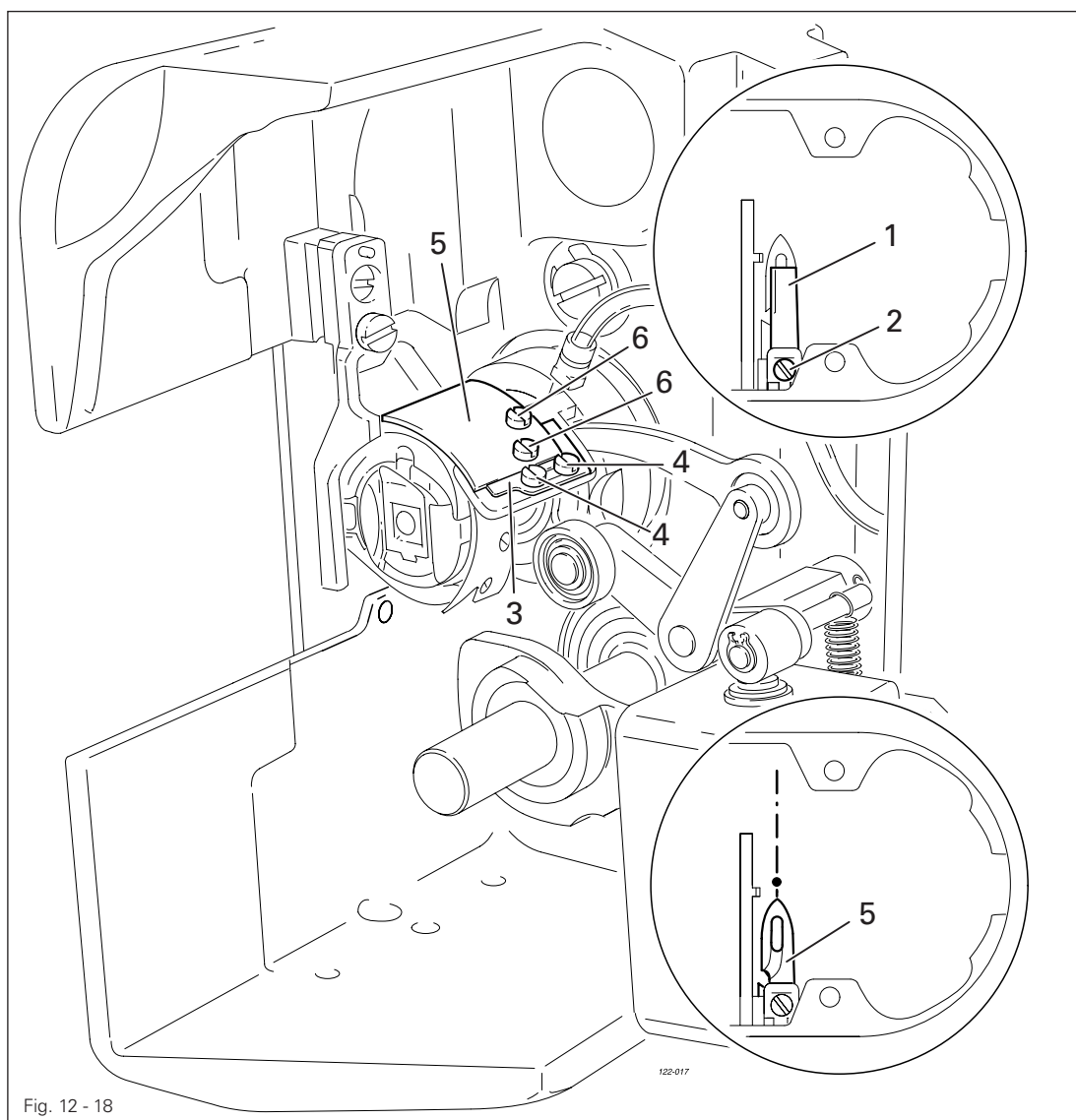
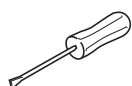

Fig. 12 - 18



- Remove knife **1** (screw **2**).
- Move needle bar to its BDC.
- Loosen stop **3** (screws **4**).
- Position thread catcher **5** (screw **6**) manually in front of the needle.
- Align thread catcher **5** (screws **7**) according to the requirements.



For further adjustments, leave knife **1** removed and stop **3** loosened.

## 12.07.03 Knife position

**Requirement**

1. There must be a distance of 4 mm between the cutting edge of the knife and the needle.
2. The right edge of the knife 1 must not extend beyond the right edge of the thread catcher (see arrow).

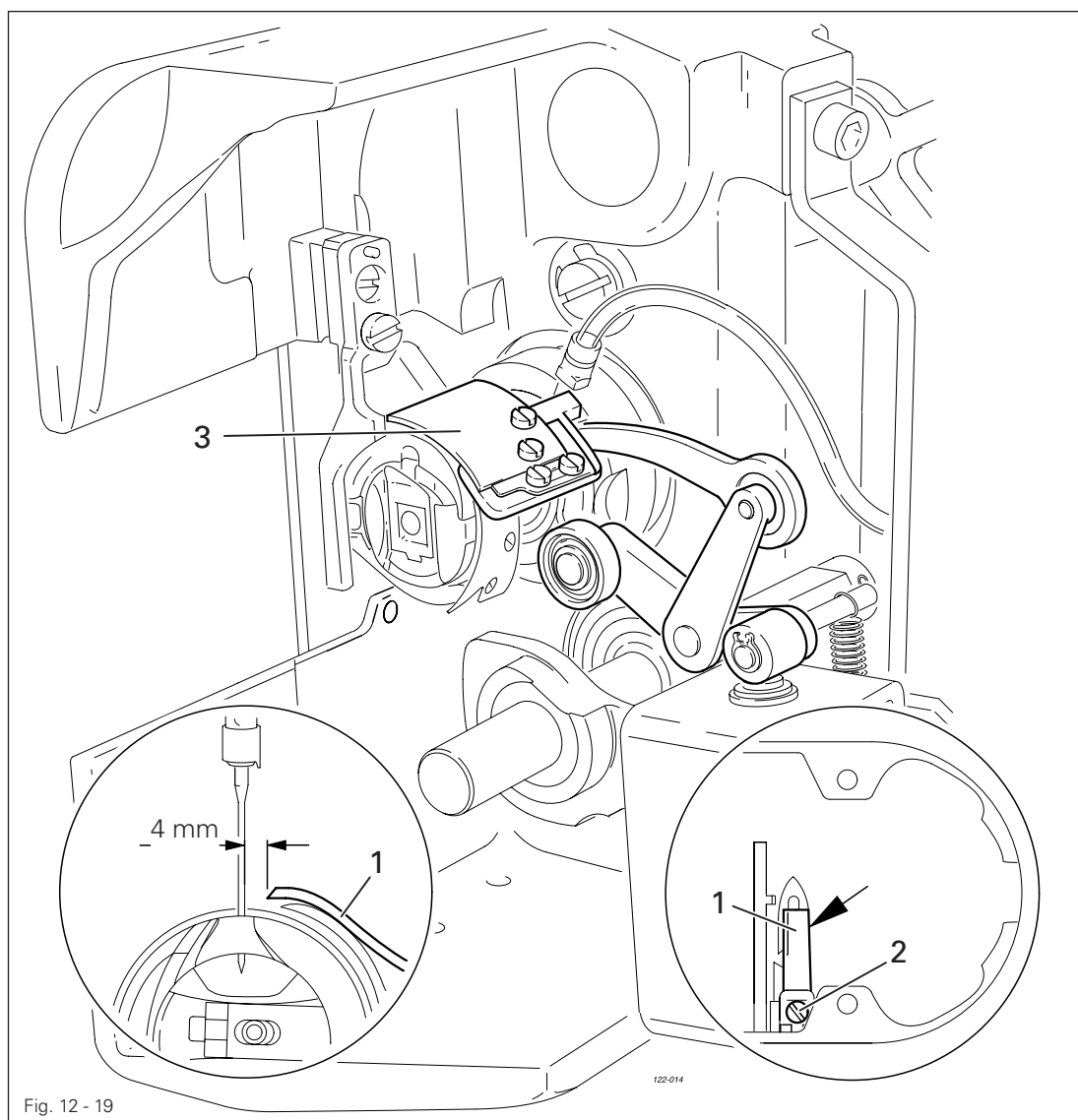
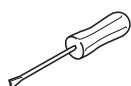

Fig. 12 - 19



- Bring the needle bar to BDC.
- Slide knife 1 under the locking tab and align according to requirement 1.
- Tighten screw 2 lightly.
- Adjust thread catcher carrier 3 by hand until the wedge point in the thread catcher is positioned just in front of the cutting edge of the knife.
- Align knife 1 according to requirement 2 and tighten screw 2.

## Adjustment

### 12.07.04 Front point of reversal of the thread catcher

#### Requirement

At the front point of reversal of thread catcher **4**, the tip of the thread catcher cutout should be **1 mm** in front of the bobbin case position finger **5**.

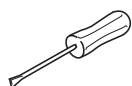
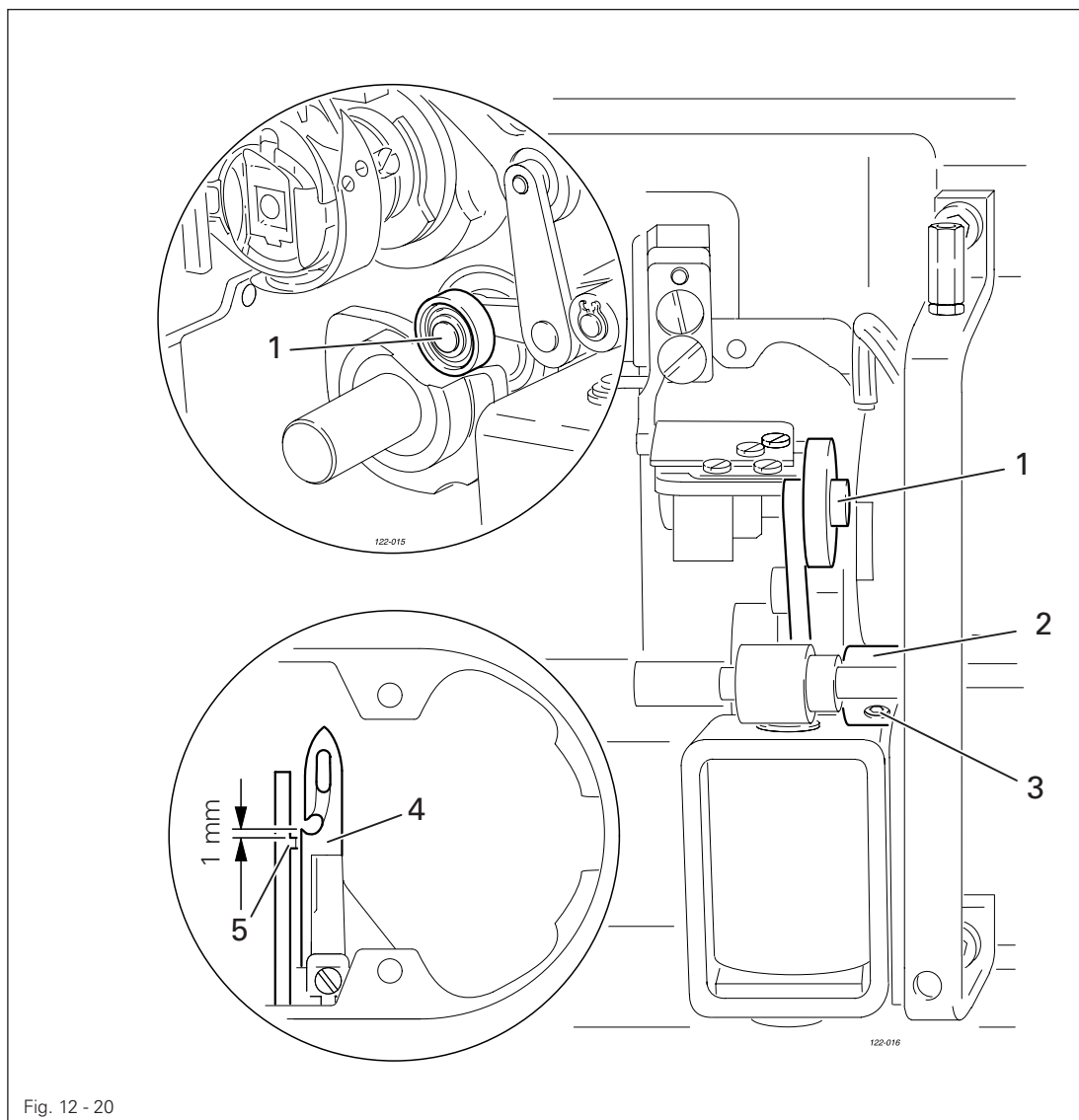

- Position roller lever **1** at the lowest point of the control cam.
- Adjust bush **2** (screws **3**) according to the requirement.

## 12.07.05 Manual trimming check

**Requirement**

Two threads must be cut perfectly both left and right in the cutout of thread catcher 1.

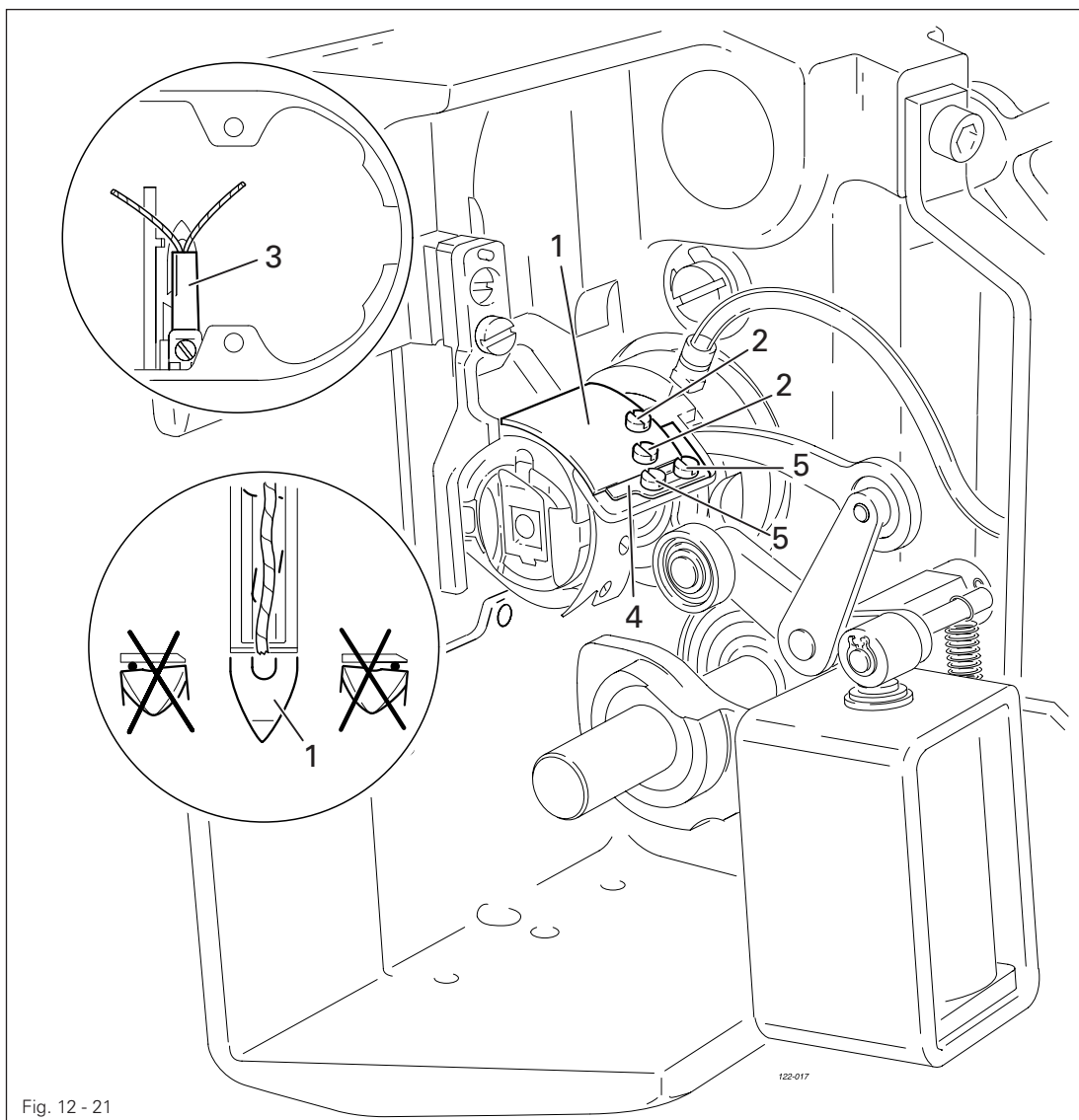
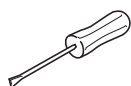

Fig. 12 - 21



- Move thread catcher 1 by hand to its front point of reversal.
- Double the thread and insert into catcher cutout.
- Carry out trimming operation manually.
- If the threads are not cut according to the requirement, align thread catcher 1 (screws 2) with knife 3 accordingly.
- Move stop 4 against thread catcher 1 and tighten screws 5.
- Check chapter 12.07.02 Lateral alignment of the thread catcher, and readjust if necessary.

# Adjustment

## 12.07.06 Needle thread tension release

### Requirement

1. The magnet lift should be **1.5 mm**.
2. When the magnet **5** is operated by hand, there should be a distance of at least **0.5 mm** between the tension discs **6**.

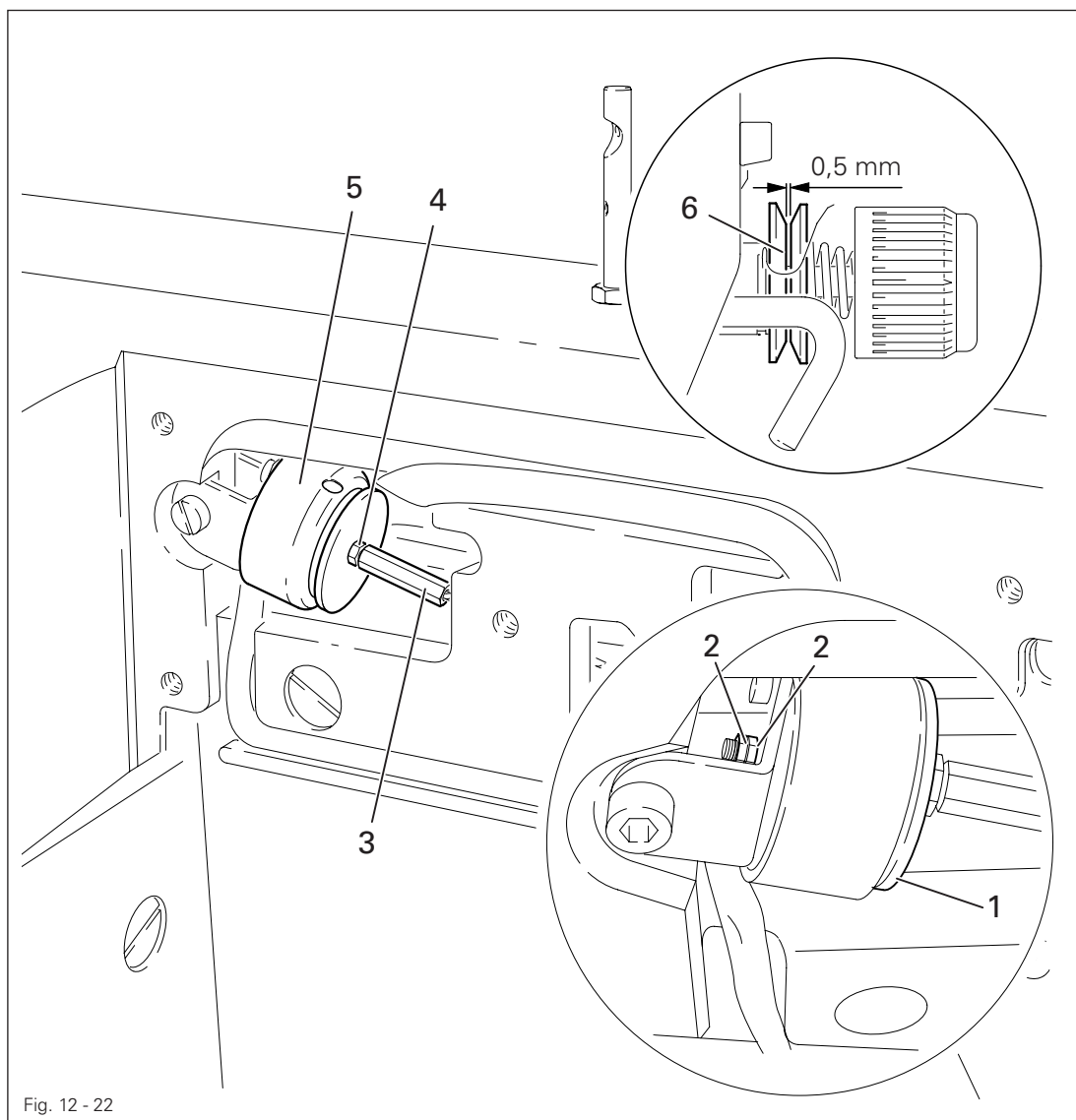
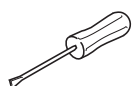

Fig. 12 - 22



- Adjust disc **1** (nuts **2**) according to the requirement.
- Adjust screw **3** (nut **4**) according to the requirement.

## 12.07.07 Readjusting the control cam

### Requirement

When the take-up lever is in its t.d.c., control cam 1 should have moved thread catcher 3.

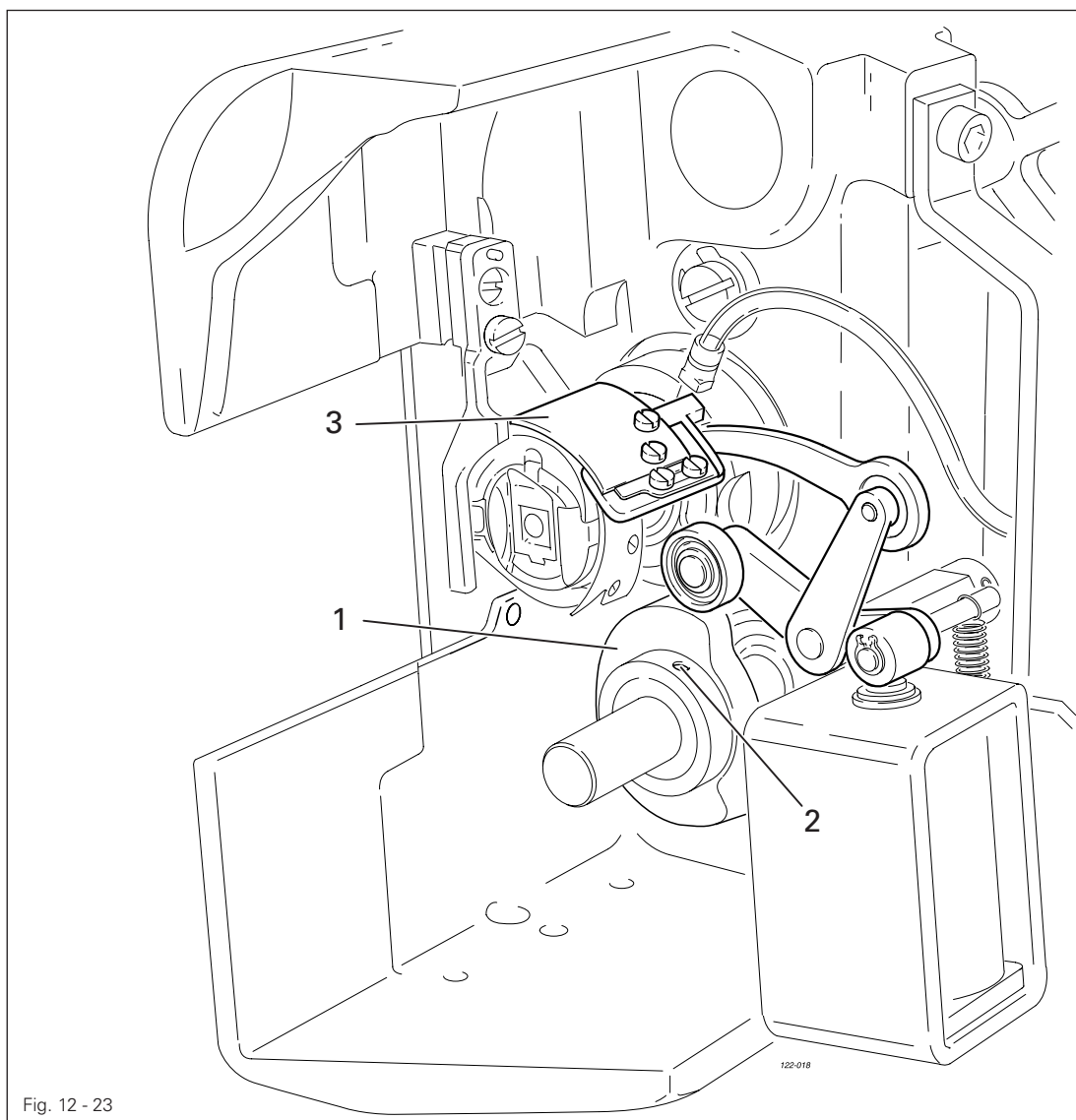
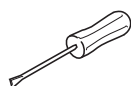

Fig. 12 - 23



- Adjust control cam 1 (screws 2) according to the requirement.

## 12.08 Adjusting the automatic presser foot lift

### Requirement

When the automatic presser foot lift is activated there should be a clearance of 7 mm between the presser foot and the top part of the needle plate.

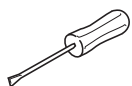
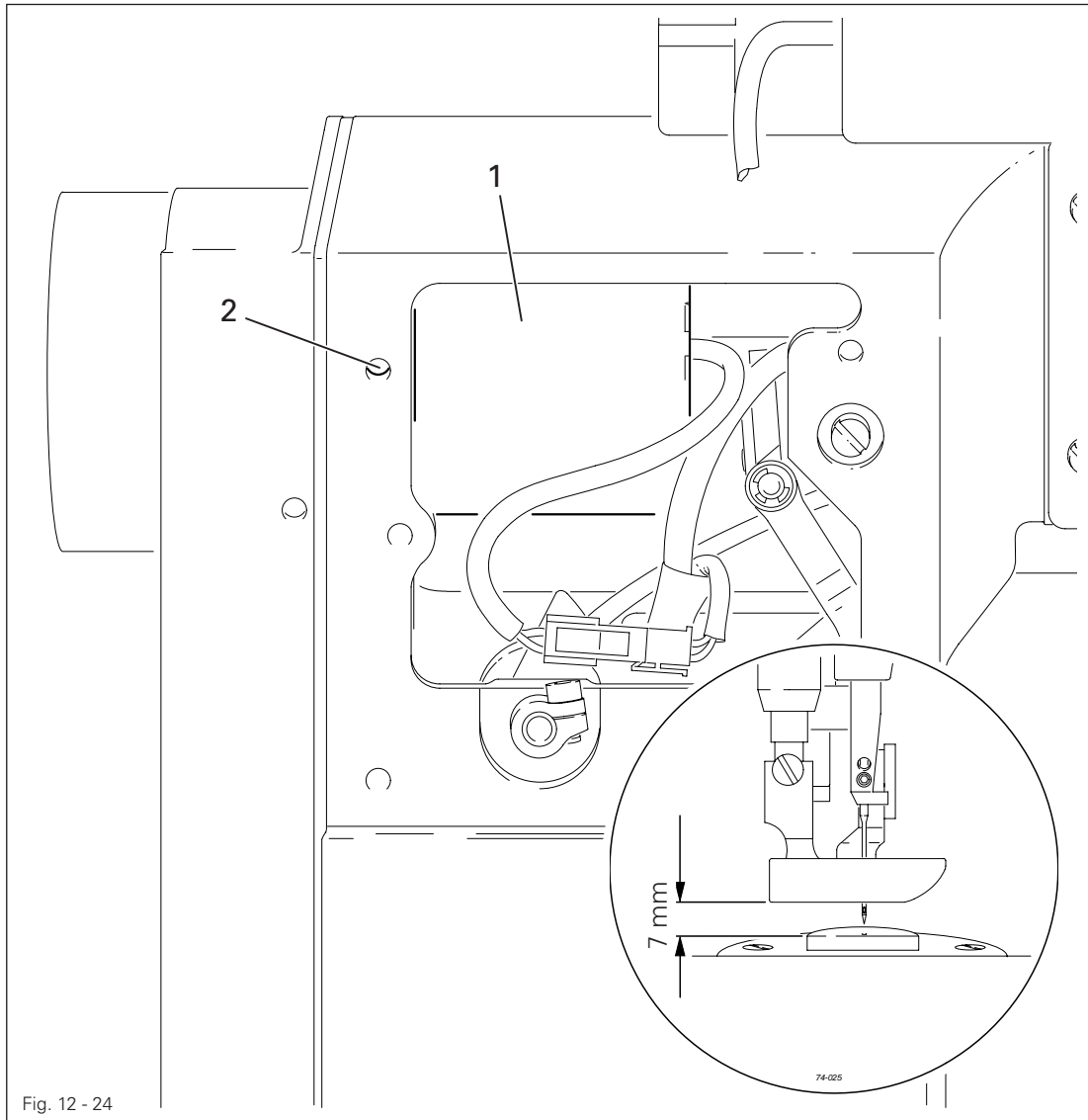

- Move magnet 1 (screw 2) according to the requirement.



## 12.09 Adjusting the jig drive

### 12.09.01 Position of the jig drive in the sewing direction

#### Requirement

Drive 1 should be parallel to and at a distance of 6 mm to the edge of the bed plate.

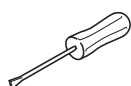
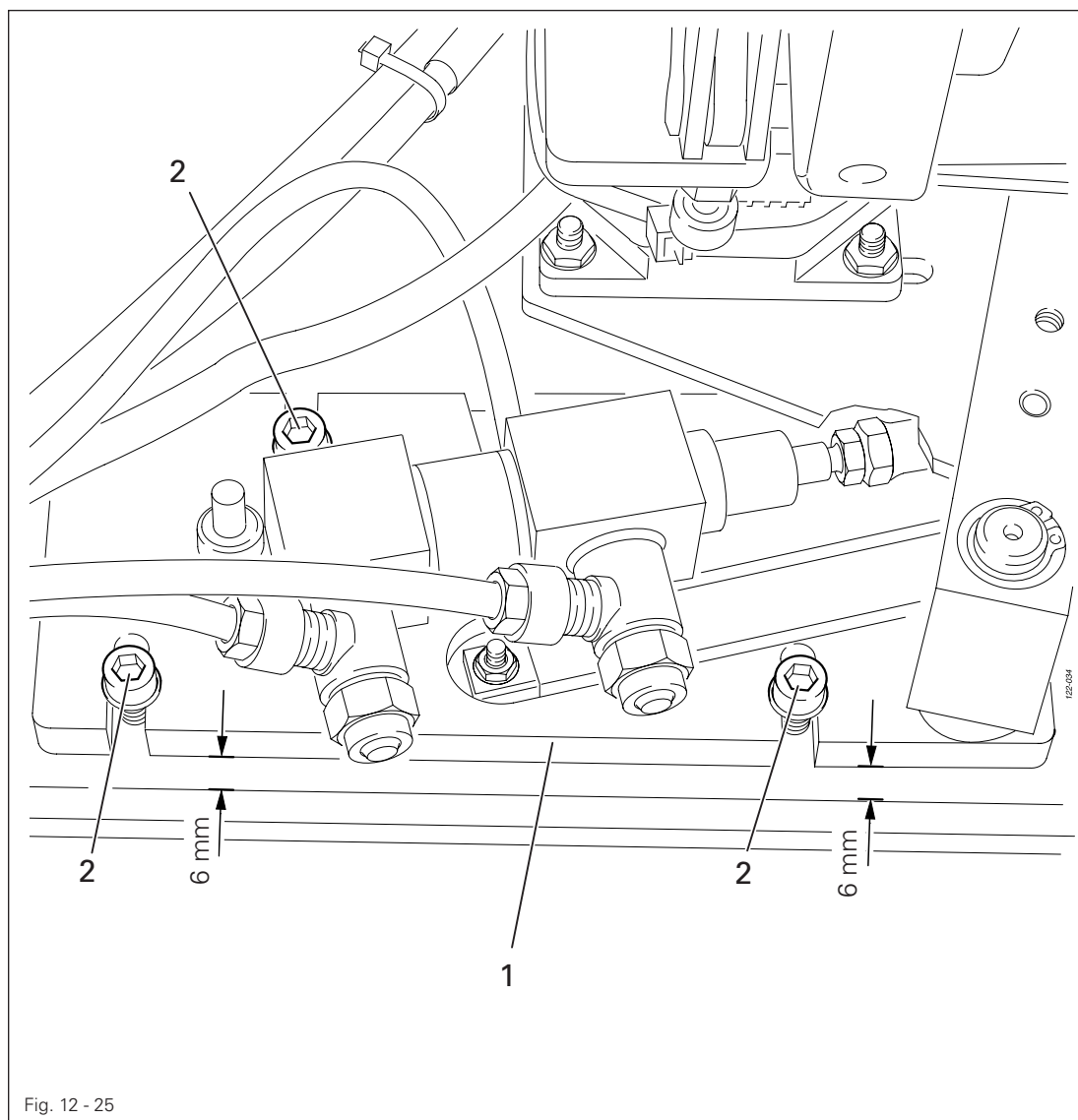

- Adjust drive 1 (screws 2) in accordance with the requirement.

# Adjustment

## 12.09.02 Position of the jig drive crosswise to the sewing direction

### Requirement

Drive wheel 3 should firmly touch the sewing jig at all times.

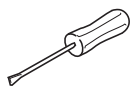
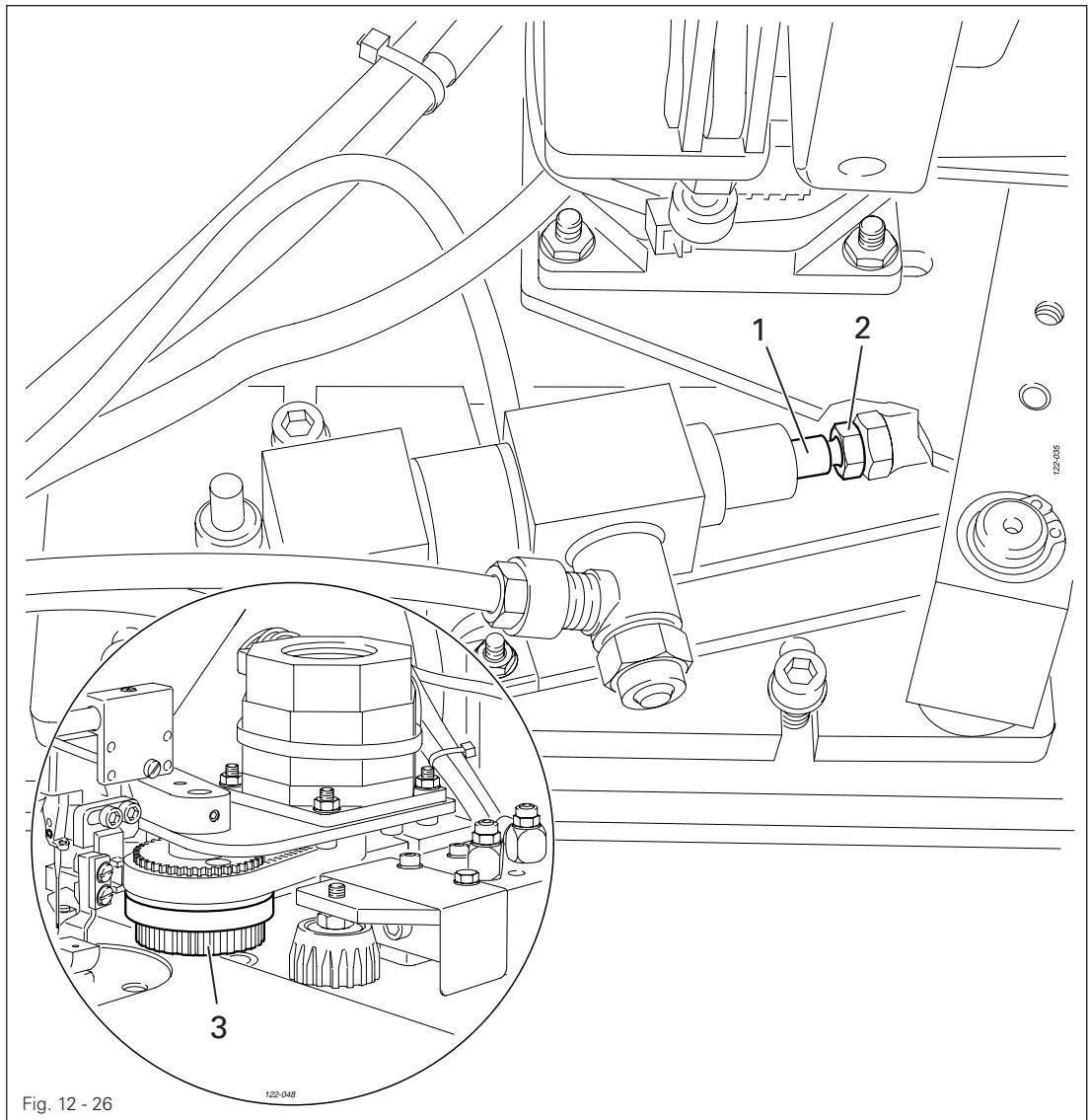

- Adjust piston rod 1 (nut 2) in accordance with the requirement.

## 12.09.03 Jig drive contact pressure

### Requirement

1. The sewing jig must be transported reliably at all times.
2. The contact pressure should be as low as possible.

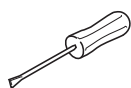
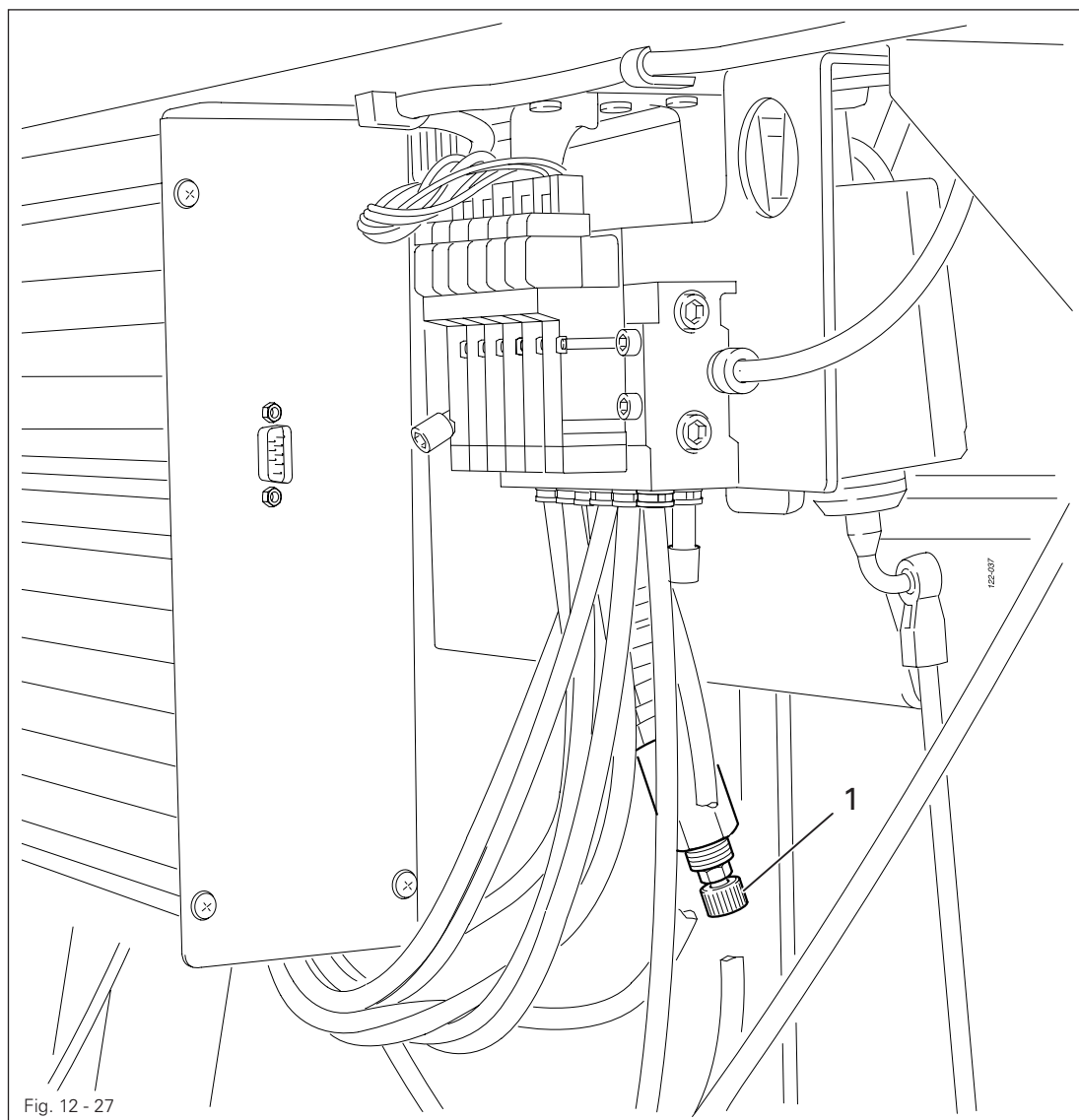

- Adjust throttle 1 in accordance with the requirements.

# Adjustment

## 12.09.04 Adjusting the support roller

### Requirement

When the support roller **3** is extended, the sewing jig should be guided parallel to the edge of the cover plate.

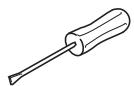
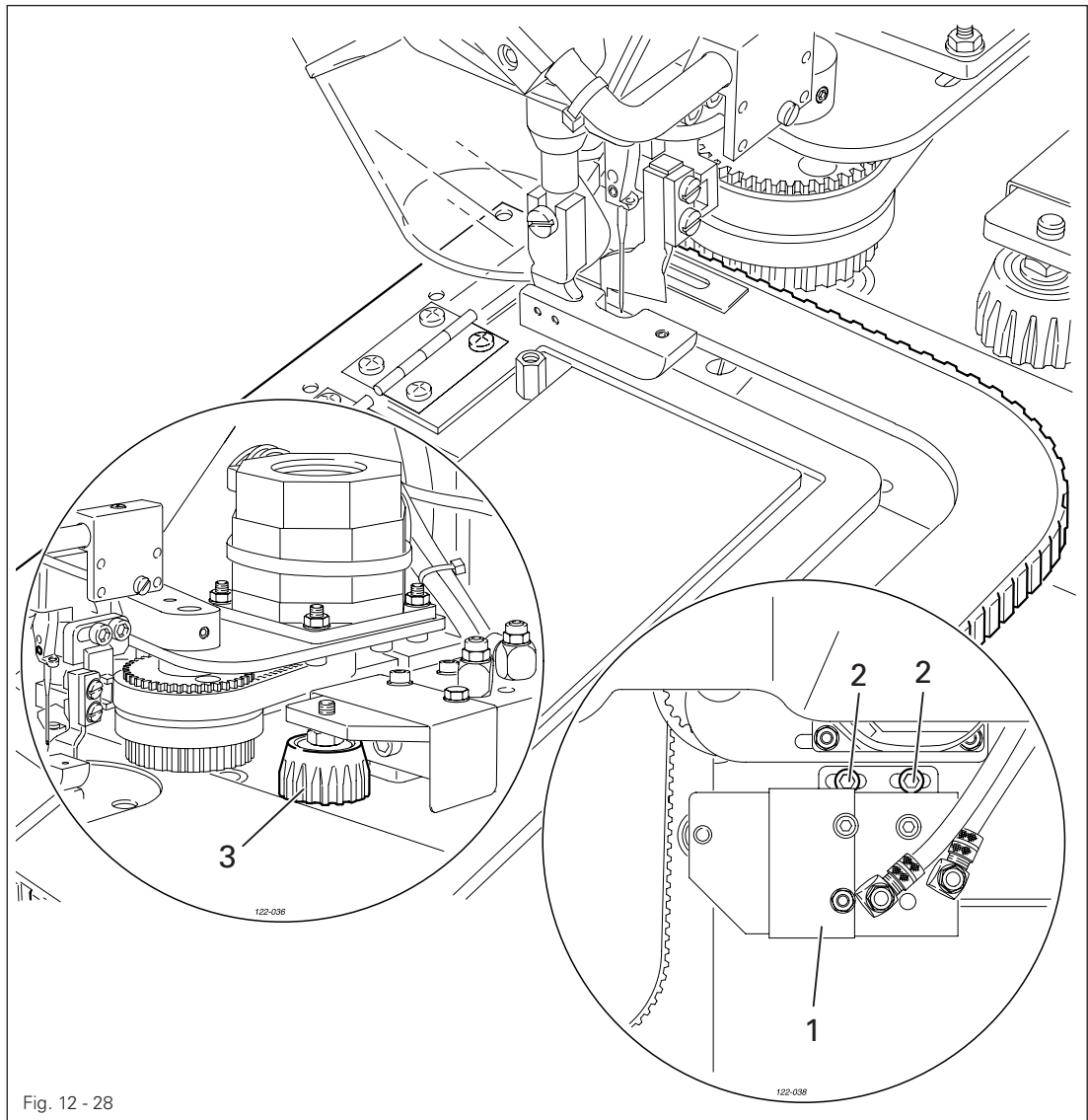

- Adjust unit **1** (screws **2**) in accordance with the requirement.

## 12.10 Adjusting the retainer

**Requirement**

1. The distance between the retainer 1 and the edge trimmer 3 should be as short as possible.
2. Retainer 1 and edge trimmer 3 should not touch each other.

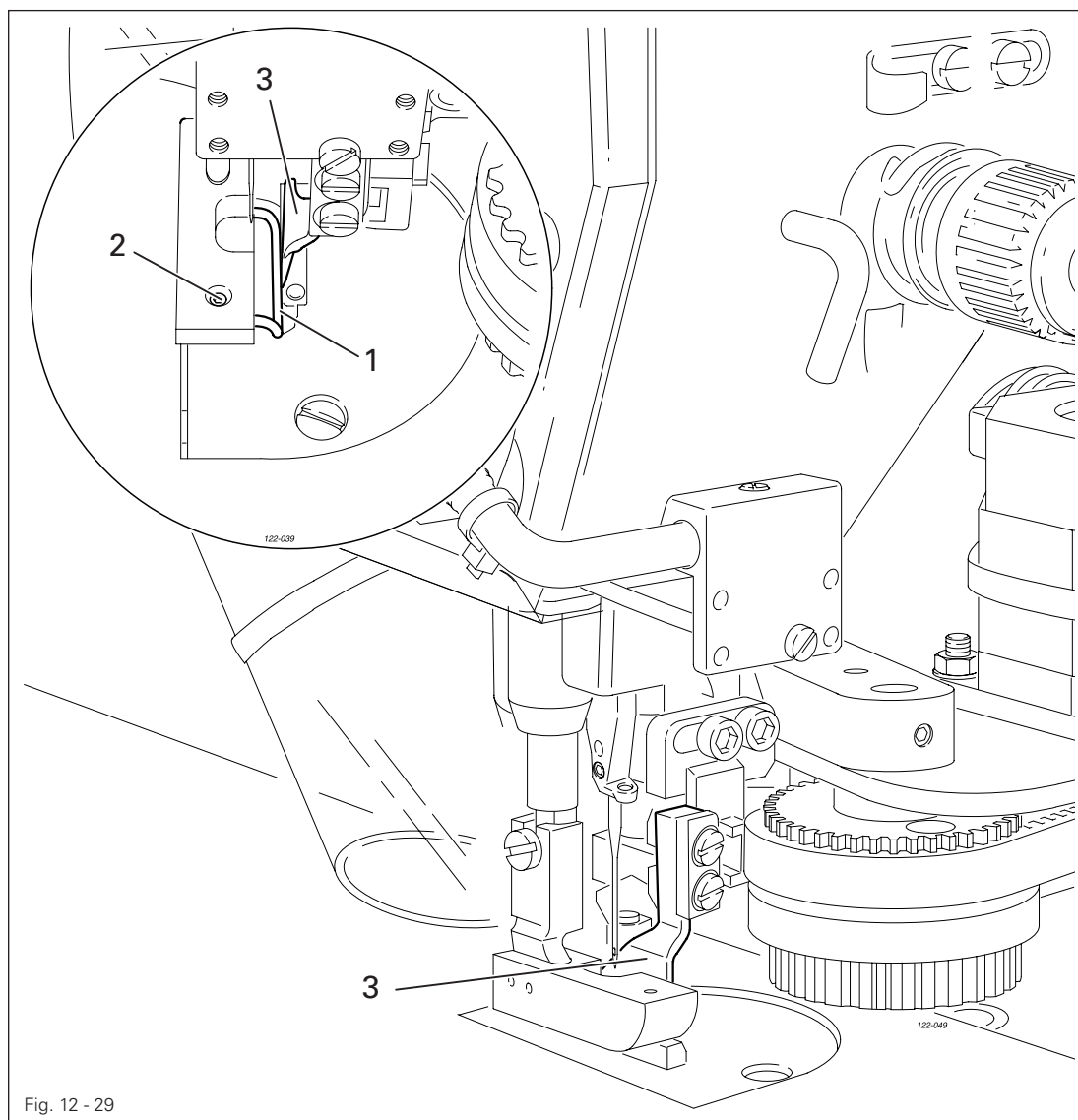
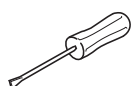

Fig. 12 - 29



- Adjust retainer 1 (screw 2) in accordance with the requirements.

# Adjustment

## 12.11 Adjusting the photo sensor and jig stop

### Requirement

1. The scanning point of photo sensor 1 should always be at a distance of 15 mm to the edge of the needle plate (see enlarged section of the illustration).
2. Adhesive tape 3 should be attached to the jig in such a way that it is flush to the edges of the jig (see arrows).
3. The first needle penetration (seam start) should be within the material.

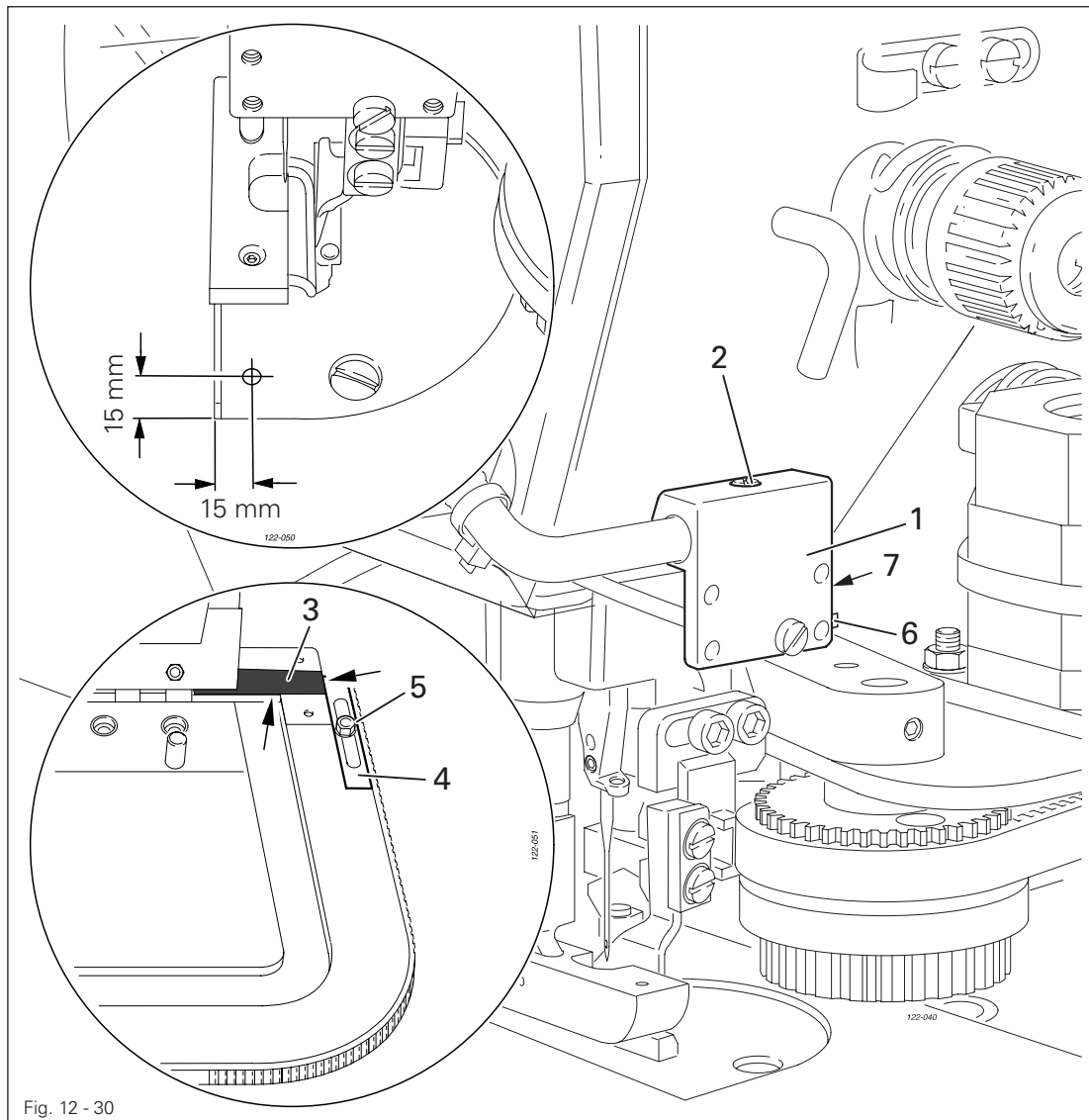
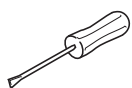

Fig. 12 - 30



- Adjust photo sensor 1 (screw 2) in accordance with requirement 1.
- If necessary, correct the position of the adhesive tape 3 in accordance with requirement 2.
- Adjust stop 4 (nut 5) in accordance with requirement 3.

### Aligning the photo sensor

- Bring the sensor to the static teach-in mode by pressing button 6 for approx. 2 seconds until LED 7 flashes green.
- Position the jig with adhesive tape 3 under the scanning point of photo sensor 1 and press button 6 on the sensor for a short time. (ON-position of the sensor)
- Remove the jig and press button 6 again for a short time. (OFF-position of the sensor)

## 12.12 Parameter settings

### 12.12.01 Selecting the user level



As a standard, when the machine is switched on, it is in user level "a". Below is a description of how to call up the service level "c" via mechanic level "b". The set values in the parameters of the user level "b" and "c" may only be altered by appropriately trained personnel!

- Switch on the machine.



- If necessary call up the manual sewing mode. (The LED in the key is not illuminated.)



- Call up parameter input.

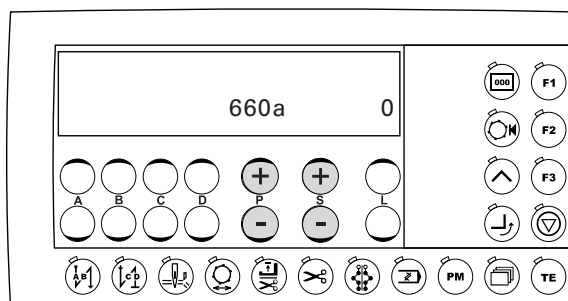

- Call up parameter "798" by pressing the appropriate +/- keys (P) or (S).

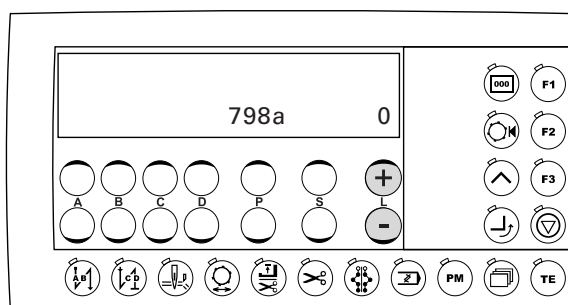

- Enter the appropriate value for the desired user level by pressing the +/- keys (L):

0 = operating level "a"  
 1 = mechanic level "b"  
 11 = service level "c"



- Press the TE key to conclude the selection.



After the machine has been switched off and then on again the user level "a" is reactivated. The corresponding letter "a", "b" or "c" for the current user level is shown on the display.

## 12.12.02 Example of parameter input

- Switch on the machine.



- Press the TE key to call up the parameter input function.

The selection of the editable parameter depends on the active user level, see Chapter 12.12.01 Selecting the user level and Chapter 12.12.03 List of parameters.

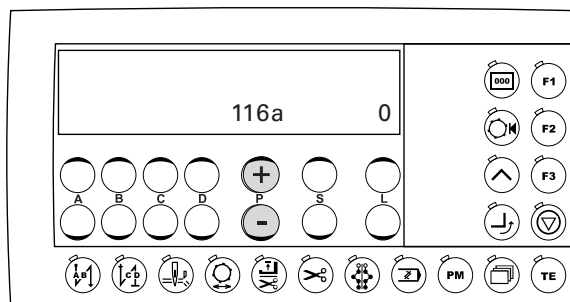

- Press the +/- keys (P) to select the desired parameter, e.g. parameter "660" (bobbin thread monitoring).

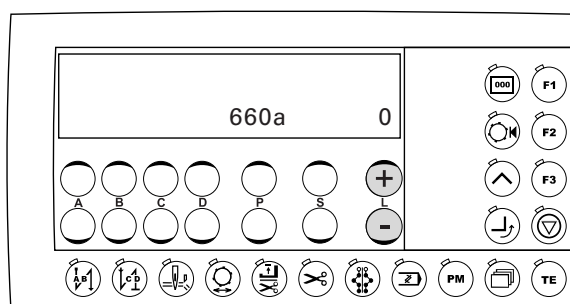

- Press the +/- keys (L) to set the desired value for the parameter, e.g. value "2" (bobbin thread monitoring by stitch counting).

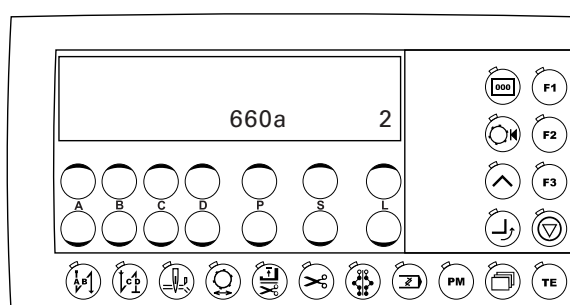

The value for the number of stitches for the bobbin thread monitoring can be entered with parameter "760".



- Press the TE key to take over the values of the altered parameter and to call up the sewing mode.



## 12.12.03 List of parameters

Group	Parameter	Description	User level	Setting range	Set value
1	105	Seam start speed	B,C	300 - 1500	1000
	110	Seam end speed	B,C	300 - 1500	1000
	116	Soft start stitches	B,C	0 - 30	0
	117	Speed for soft start stitches	B,C	30 - 1000	400
3	382	Switching threshold of the analog input for the thread monitor	B,C	0 - 100	15
	387	Output Ax (motor running) is activated 1 = with pedal 1D (motor running) 0 = with pedal 1 (lower presser foot)	B,C	0 - 1	1
4	407	Cable fault detection on speed control unit 1 = on; 0 = off	B,C	0 - 1	1
	452	Input "operation lock" 1 = on; 0 = off (no function)	B,C	0 - 1	1
5	521	Needle position if sewing stop before seam end 1 = needle position "2" (take-up lever raised); 0 = needle position "1" (lowered)	B,C	0 - 1	1
	538	Tacting output Ax (thread tension release) 0 = 100% power up	B,C	10 - 50	30
6	605	Actual value on display 1 = on; 0 = off	B,C	0 - 1	0
	606	Speed level 1 (min.)	B,C	30 - 300	180
	607	Speed level 2 (max.)	B,C	300 - 3500	2500
	609	Cutting speed 1	B,C	60 - 300	180
	615	End recognition with photo sensor 1 = from bright to dark; 0 = from dark to bright	B,C	0 - 1	1
	618	Reversing after seam end 1 = on; 0 = off	B,C	0 - 1	1
	623	Switch on delay for reversing [ms]	B,C	0 - 2000	30
	660	Bobbin thread monitoring 0 = without monitoring 1 = with sensor 2 = with stitch counting	A,B,C	0 - 2	0

## Adjustment

Group	Parameter	Description	User level	Setting range	Set value
6	668	Thread wiper / thread blower 1 = on; 0 = off	B,C	0 - 1	1
7	700	Needle position "0" (needle reference position)	B,C	0 - 255	0
	702	Needle position "1" (needle lowered)	B,C	0 - 255	80
	703	Needle position "2" (take-up lever raised)	B,C	0 - 255	226
	705	Needle position "5" (magnetic thread trimming / end of cutting signal "1", start of tacting of cutting signal "1")	B,C	0 - 255	200
	706	Needle position "6" (pneumatic thread cutting / start of cutting signal "2")	B,C	0 - 255	80
	707	Needle position "9" (start thread tension release / start thread catcher)	B,C	0 - 255	164
	715	Switch on time for thread wiper [ms]	B,C	0 - 2000	90
	718	Stop brake tacting 0 = brake off	B,C	0 - 100	0
	719	Tacting adjustment A4 (presser foot) 0 = 100 % power up	B,C	10 - 60	40
	722	Acceleration ramp 1 = flat; 50 = steep	B,C	1 - 60	50
	723	Brake ramp 1 = flat; 50 = steep	B,C	1 - 60	40
	729	Start delay after lowering presser foot [ms]	B,C	10 - 2000	150
	730	Delay for raising presser foot after seam end [ms]	B,C	0 - 2000	50
	734	Tacting output A2 (thread trimming)	B,C	10 - 60	40
760	No. of stitches for remaining thread after response of bobbin thread monitor with direct bobbin thread monitoring (with sensor) Multiplier for the fixed value "200" for determining initial value for stitch counter with indirect bobbin thread monitoring (with stitch counting)	A,B,C	0 - 250	5	

Group	Parameter	Description	User level	Setting range	Set value
7	761	Extension thread tension release / thread drawing	B,C	0 - 80	0
	770	Delay for raising pressure foot when pedal set at "-1"	C	10 - 250	80
	789	Needle position "10" (bearing position)	B,C	0 - 255	239
	797	Hardware test 1 = on; 0 = off	C	0 - 1	0
	798	User lever "C" 1 = on; 0 = off	B,C	0 - 1	0
	799	Selected machine class	C	1	1
8	800	Motor rotation direction when looking at V-belt pulley 1 = anti-clockwise; 0 = clockwise	C	0 - 1	0
	801	Reversing angle at end of seam	B,C	10 - 212	16
	880	Max. starting power [A]	C	1 - 30	10
	884	Proportional sensitivity of the speed control unit (general)	B,C	1 - 24	10
	885	Integral sensitivity of the speed control unit	C	10 - 80	50
	886	Proportional sensitivity of the positioner	C	1 - 15	8
	887	Differential sensitivity of the positioner	C	1 - 15	8
	889	Time for positioning action 0 = always	C	0 - 2500	400
	890	Proportional sensitivity of the superset positioner for stop brake	C	1 - 25	15
	897	MINI-motor variant 1 = long; 0 = short	C	0 - 1	0
898	No existing comment	C	0	0	
9	900	Additional P-sensitivity for speed control unit	B,C	1 - 24	12
	901	Cutting release - speed	B,C	30 - 500	300
	933	Switchover for display 1 = diagnosis; 0 = normal display	C	0 - 1	0
10	1000	Number of steppers	B,C	0 - 1	1
	1001	Starting angle of stepper	B,C	0 - 255	110
	1003	Feed roller radius	C	5 - 50	11

## Adjustment

Group	Parameter	Description	User level	Setting range	Set value
11	1100	Operating mode of stepper 1 (puller, differential-regulation etc.)	C	0 - 1	1
	1101	Rotation direction of stepper 1 1 = anti-clockwise; 0 = clockwise	C	0 - 1	1
	1102	Stepping mode of stepper 1 1 = full step 2 = half-step 3 = quarter step 4 = eighth step	C	1 - 4	2
	1103	Maximum current stepper 1 [%]	C	1 - 100	90
	1104	Reducing current stepper 1 [%]	C	0 - 60	50
	1105	Start-stop-time for stepper 1, (time for one step at start-stop-speed)	C	10 - 4000	250
	1106	Pulse time for stepper 1 (time for one step at pulse speed)	C	10 - 4000	820
	1107	Acceleration for stepper 1 (percentage increase of speed from start- stop to pulse speed)	C	1 - 50	8
	1108	Number of brake steps of stepper 1	C	1 - 50	5
	1110	Offset after reference run	C	0 - 30	5
	1111	Adjustment range of stepper 1	C	0 - 100	100

## 12.13 Explanation of the error messages

### 12.13.01 Sewing motor errors

Error message	Description
Error 1	Pedal in operation at switch-on
Error 9	Start inhibitor at stop (sewing head tilted)
Error 10	Incorrect machine class or machine class changed
Error 50	Cable speed control unit
Error 62	Short circuit <b>24 V</b>
Error 63	Power supply unit overloaded ( <b>24 V</b> )
Error 65	Extint low at initialisation
Error 66	Short circuit <b>2</b>
Error 68	Extint low in operation
Error 69	No increments (stepper start signal)
Error 70	Motor stalling
Error 71	No incremental plug
Error 74	No external Syma
Error 88	RAM-error
Error 92	Starat inhibitor for motor operation (sewing head tilted)
Error 173	Starting error

### 12.13.02 Error SD memory card

The error numbers for he SD memory card are shown in the input mode opposite the SD memory card symbol.

- 1	Error in SD card reader / no SD memory card inserted
- 4	SD memory card read-only
- 8	Incorrect file size
- 11	No directory
- 15	Overwrite

## 12.14 Hardware-Test

The hardware test is a test program, with which it is possible, with the aid of the control panel, to check various components of the control unit and the machine installation. The test is carried out by scanning five test blocks.

### 12.14.01 Carry out the hardware test

- Switch on the machine.
- Activate service level "C", see Chapter 12.12.01 Selecting the user level.
- Select parameter "797" and set it at "ON" by pressing the appropriate +/- key. Test block 1 appears on the display.
- The other test blocks can be called up by pressing the +/- key A.

### 12.14.02 Test block 1 – inputs

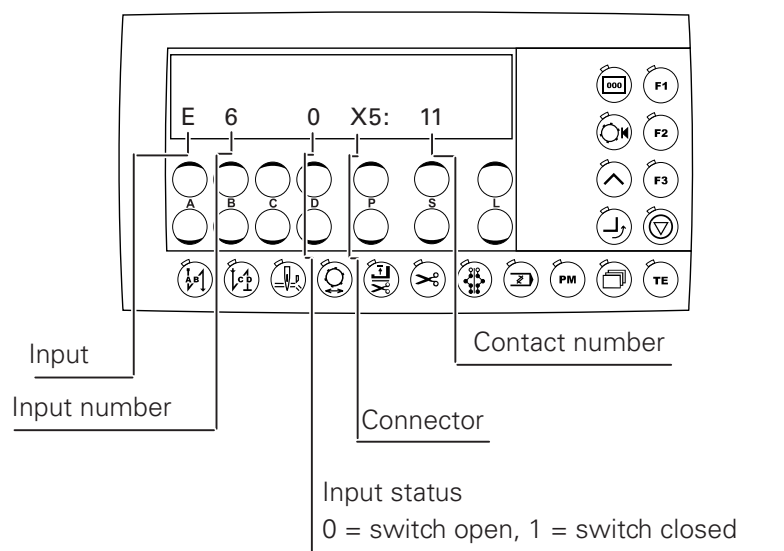

- The current input is displayed with the +/- key B.  
Press the +/- key B to display the other inputs.

## 12.14.03 Test block 2 – outputs

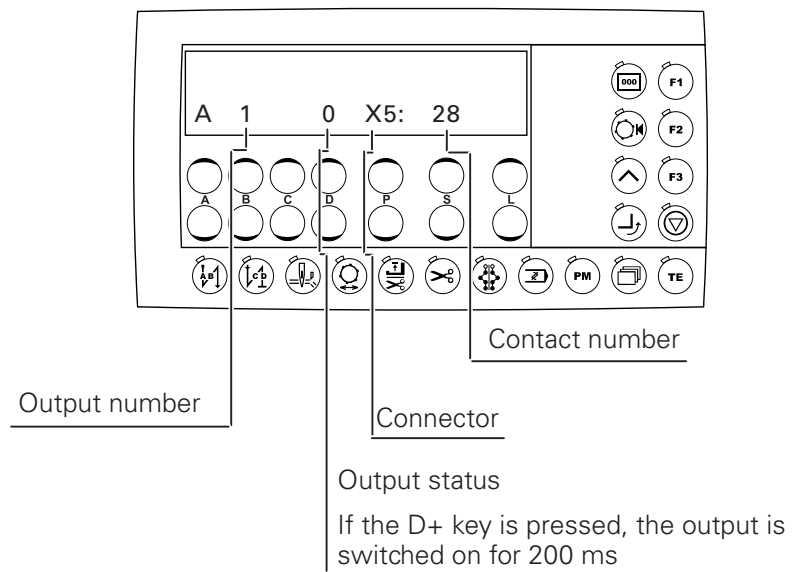

- The current output is displayed with the +/- key B.
- Press the +/- key B to display the other outputs.
- If the +/- key D is pressed, the output is switched on for 200 ms

## 12.14.04 Test block 3 – Set value sender and actual value sender

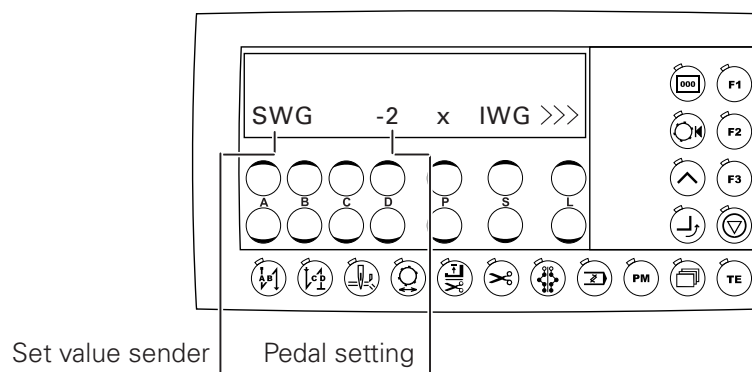

- All 16 switch positions can be called up by operating the pedal. If all positions from -2, -1, 0, 1, 1D to 12D appear on the display, the set value sender is in order.
- The actual value can be checked by turning the balance wheel. If all increments from 0 - 255 appear on the display, the actual value sender is in order.

## 12.14.05 Test block 4 – photo sensor and thread monitor

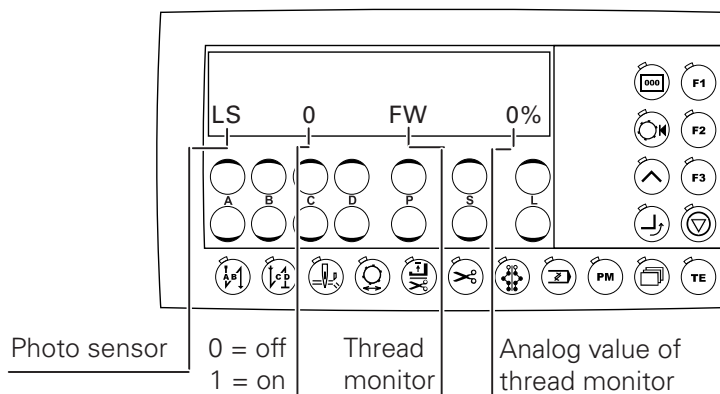

## 12.15 Reset

After the menu has been selected, by pressing the appropriate key it is possible to delete seam parameters or seam patterns, or to carry out a cold start.

- Press and hold key **P+** and key **L+** and switch on the machine.

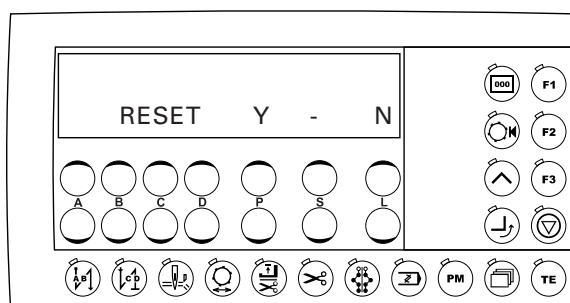

### Parameter reset

- Press the **P+** key to carry out a parameter reset.

### Program reset

- To carry out a program reset, press the **P+** key and the edge trimming key at the same time.



## 12.16 Internet update of the machine software

The machine software can be updated with PFAFF flash programming. For this purpose the PFP boot program and the appropriate control software for the machine type must be installed on a PC. To transfer the data to the machine, the PC and the machine control unit must be connected with an appropriate null modem cable (part no. 91-291 998-91).



The PFP boot program and the control software of the machine type can be downloaded from the PFAFF-homepage using the following path:  
[www.pfaff-industrial.de/pfaff/de/service/downloads](http://www.pfaff-industrial.de/pfaff/de/service/downloads)

To update the machine software carry out the following steps:



While the machine software is being updated, no setting up, maintenance or adjustment work may be carried out on the machine!

- Switch off the machine.
- Connect the PC (serial interface or appropriate USB-adaptor) and the machine control unit (RS232).
- Switch on the PC and start the PFP boot program.
- Select the machine type.
- Press the "programming" button.
- An extra program (quick loader) is started.
- Switch on the machine within **60 seconds**.
- The software update is carried out, the update progress is shown on the bar display.
- When the update has been completed, the message "**software update successfully completed**" appears.



If this message does not appear, the entire procedure must be repeated!  
The machine is not safe for operation until the programming has been completed successfully and without faults.

- Switch off the machine and end the quick loader and PFP boot program.
- End the connection between the PC and the machine control unit.
- Switch on the machine.
- A plausibility control is carried out and, if necessary, a cold start.



More information and assistance is at your disposal in the file "PFPHILFE.TXT", which can be called up from the PFP boot program by pressing the "help" button.

This is a list of the most important wearing parts.



A detailed parts list for the complete machine is included with the accessories. In case of loss, the parts list can be downloaded from the internet address [www.pfaff-industrial.de/pfaff/de/service/downloads](http://www.pfaff-industrial.de/pfaff/de/service/downloads). As an alternative to the internet download the parts lists can also be ordered in book form under part no. 296-12-19 009.

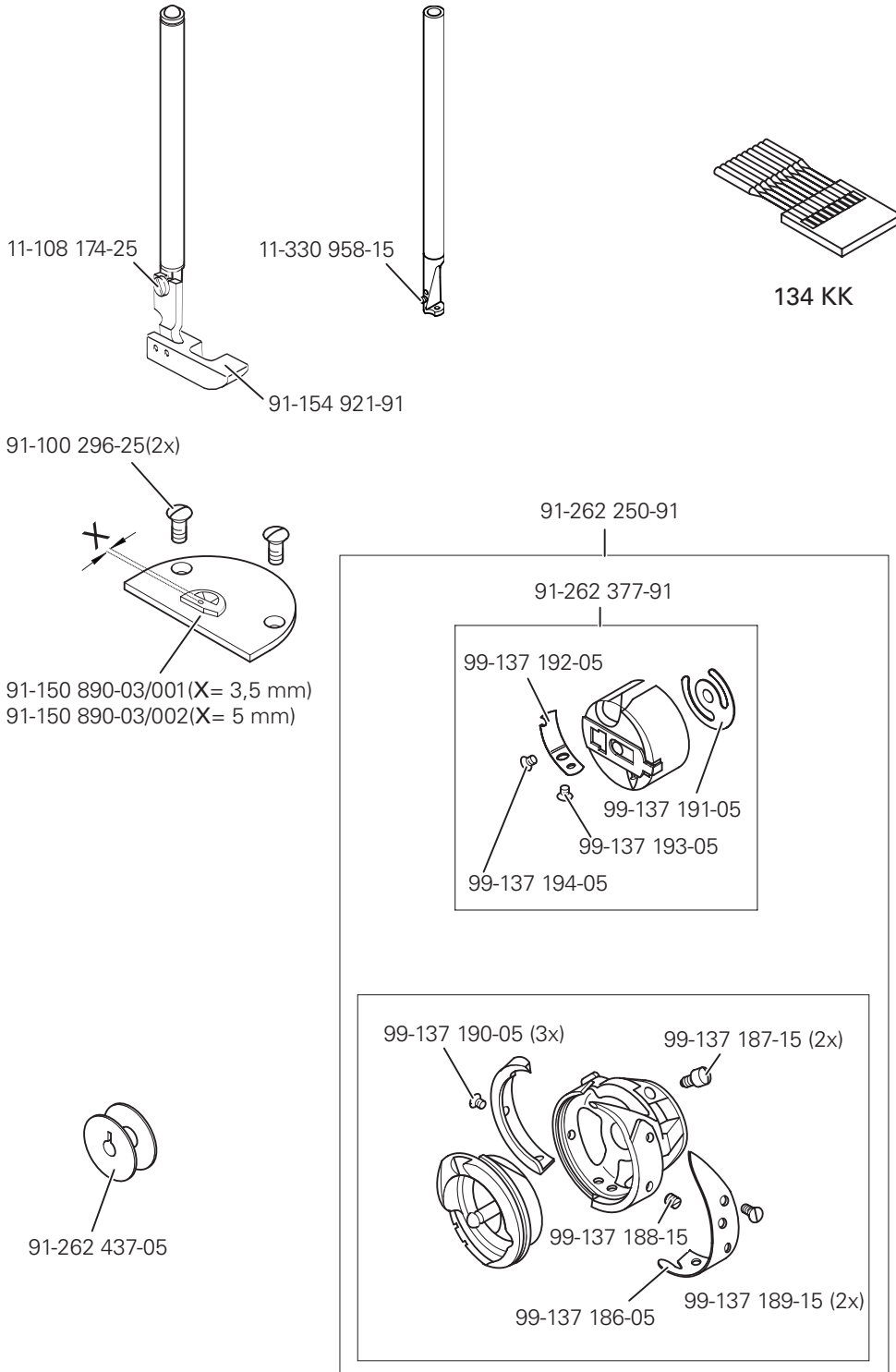

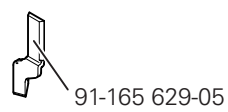
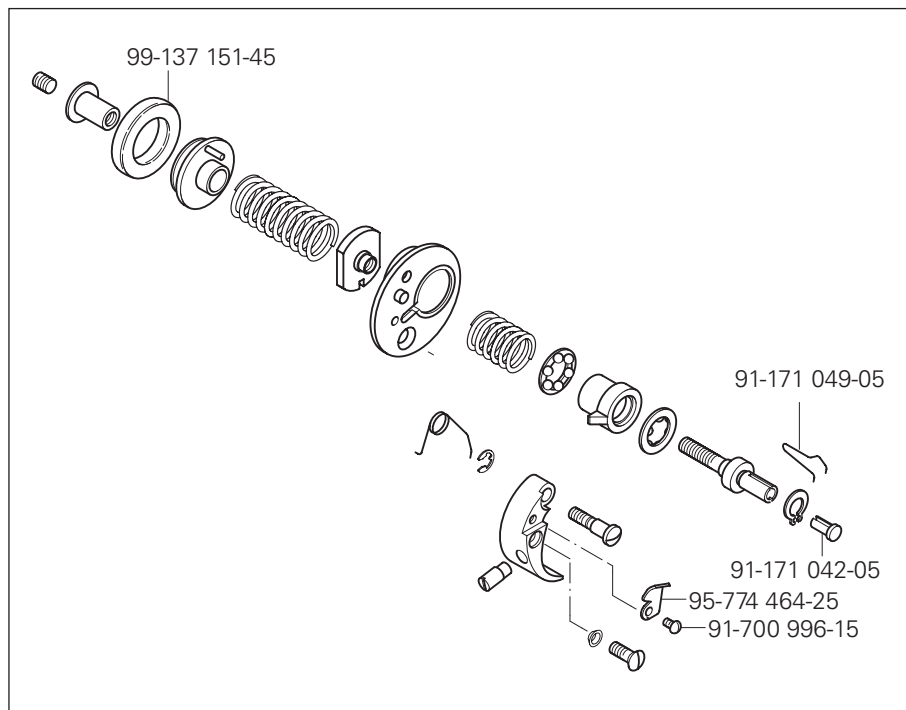
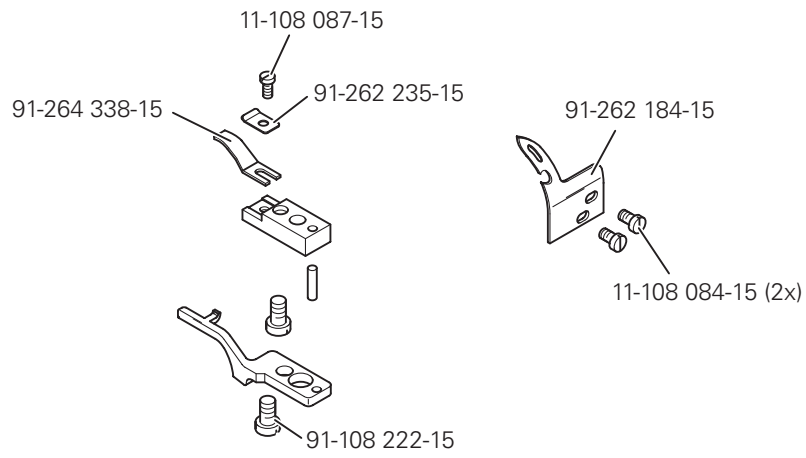

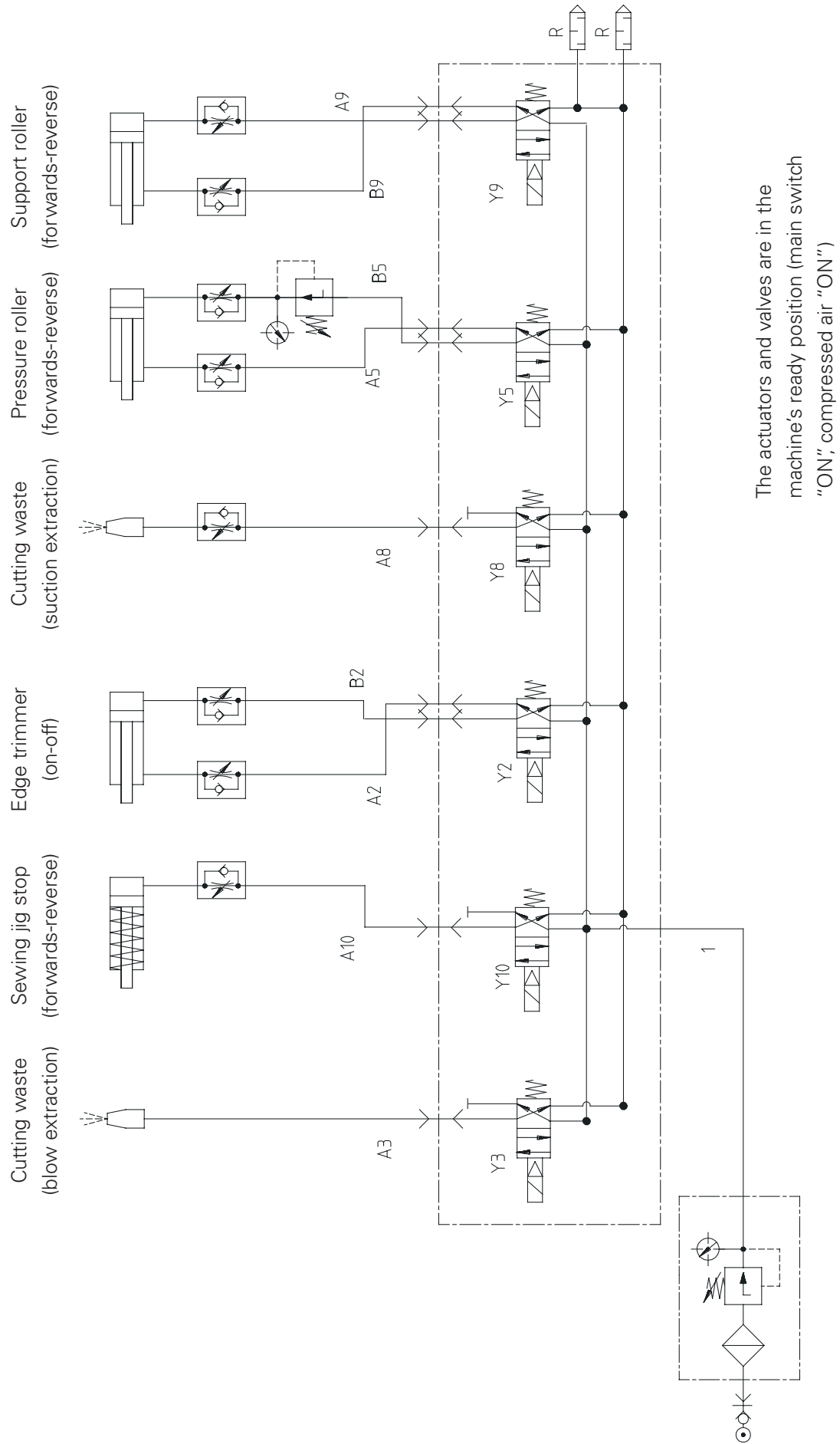

## Circuit diagram reference list

A1	Controller Quick P310 ED
A2	Control panel S31
A50	Sewing head recognition system (OTE)
B6	Photo sensor
H1	Sewing lamp
M1	Sewing motor
M2	Jig feed unit (stepper SM1)
Q1	Main switch
S1	Pedal speed control unit
S47	Start inhibitor stop
X0	Interface 1 (RS232)
X1	Sewing motor (M1)
X2	Incremental transmitter (sewing motor M1)
X3	Pedal speed control unit
X4	Control panel S31 (A2)
X4A	Jig feed (stepper SM1)
X5	Inputs and outputs
X6	Photo sensor (B6)
X7	Bobbin thread monitor (option)
X21	Jig feed (stepper SM1)
X22	Y2 Edge trimmer -731/..
X23	Y3 Blowing
X24	Y4 automatic presser foot lift (-910/..)
X25	Y5 Pressure roller
X26	Y6 Thread trimmer (-900/..)
X27	Y7 Thread tension release
X28	Y8 Suction
X29	Y9 Support roller
X30	Y10 Jig stop
X47	S47 Start inhibitor (stop)
X50	A50 Sewing head recognition system (OTE)
Y2	Edge trimmer (-731/..)
Y3	Blowing
Y4	Automatic presser foot lift (-910/..)
Y5	Pressure roller
Y6	Thread trimmer (-900/..)
Y7	Thread tension release
Y8	Suction
Y9	Support roller
Y10	Jig stop



Schrittmotor  
Steuergerät A1  
Quick P310 ED

9 poliger D-Sub

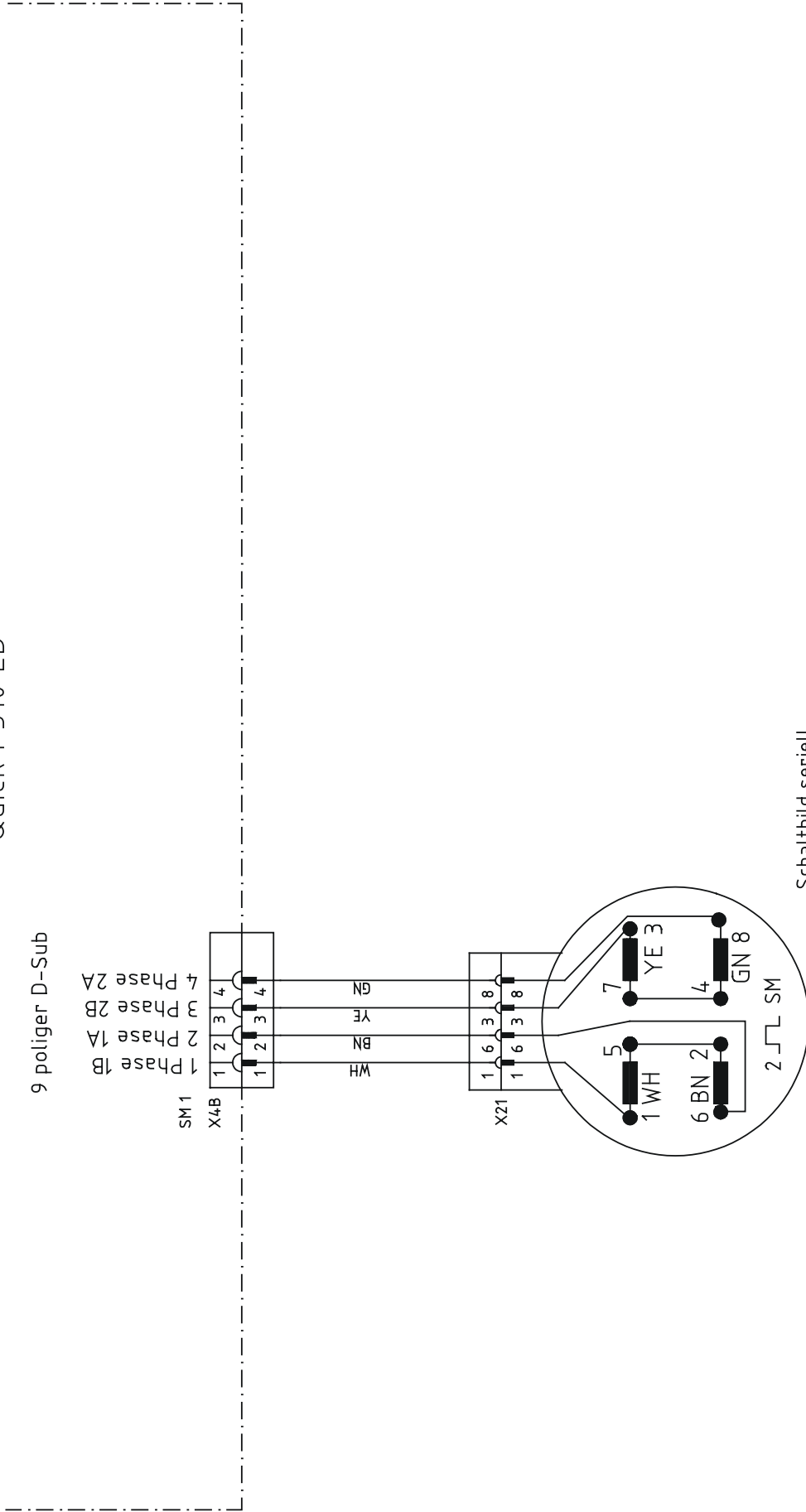

Schaltbild seriell

M2

SM 1 Schablonentransport

11 12 13 14 15 16 17 18 19 20

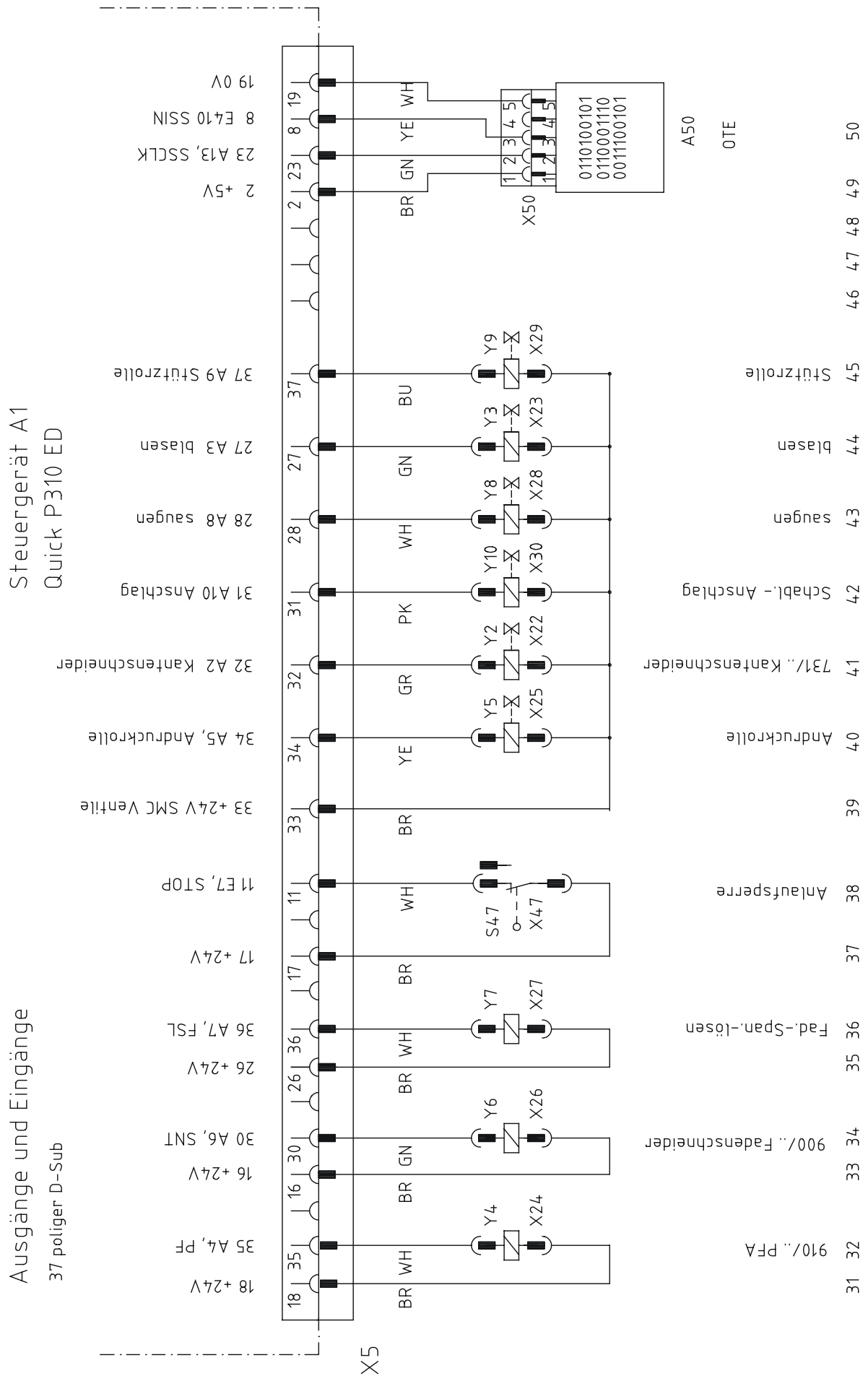



Steuergerät A1 Quick P310 ED

Sonderfunktionen

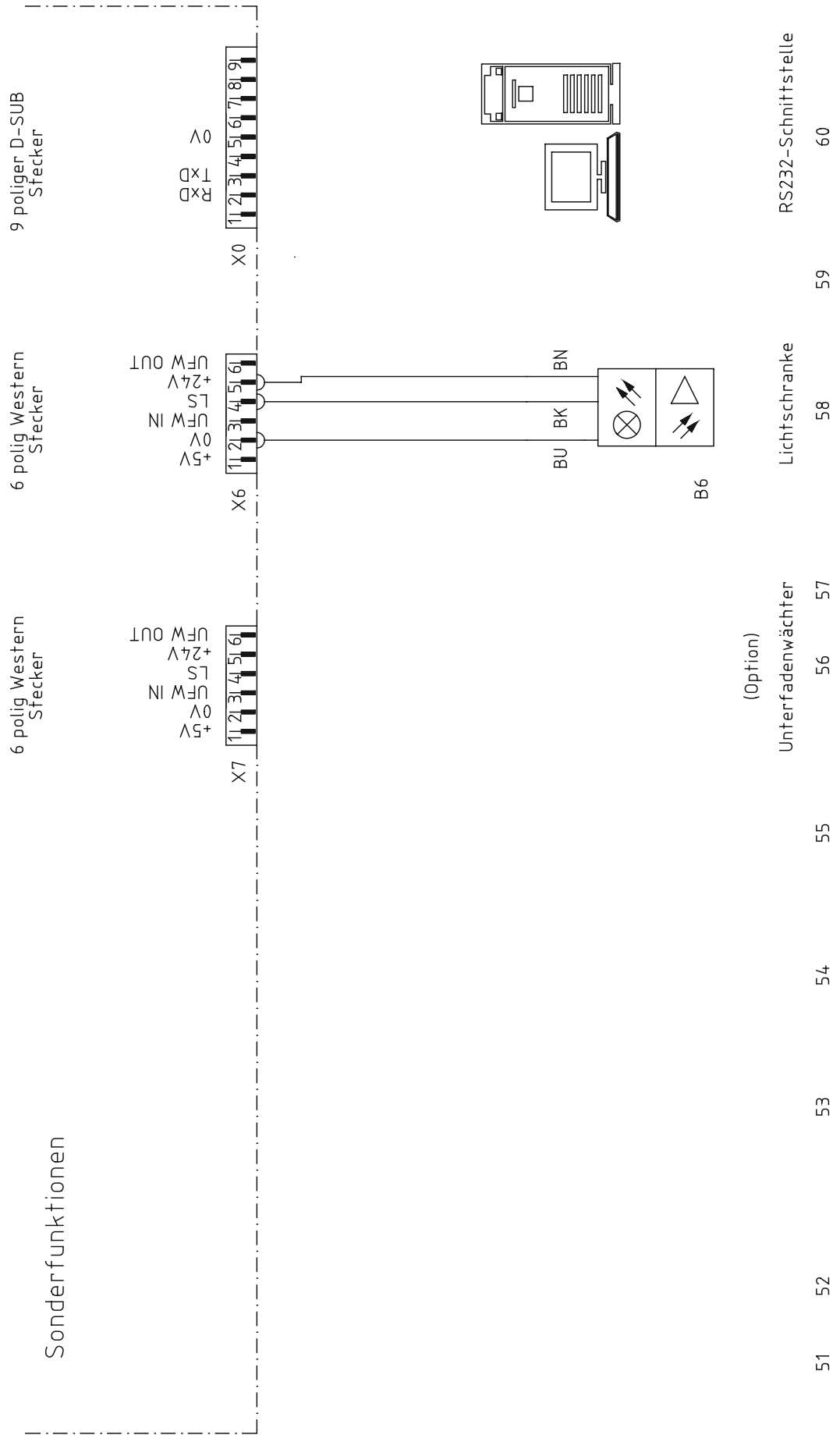



**Europäische Union**  
Wachstum durch Innovation – EFRE



## PFAFF Industriesysteme und Maschinen AG

Hans-Geiger-Str. 12 - IG Nord  
D-67661 Kaiserslautern

Phone: +49-631 200-0  
Fax: +49-631 17202  
E-mail: [info@pfaff-industrial.com](mailto:info@pfaff-industrial.com)

### Hotlines:

Technical service: +49-175/2243-101  
Application consultancy: +49-175/2243-102  
Spare-parts hotline: +49-175/2243-103