

# EcoDrive

## INSTRUCTION MANUAL

Part 1

General description

# Contents

	Page
<b>Part 1</b>	
1. General Safety Information	1.1 - 1.2
2. Technical Specifications	2.1 - 2.3
3. Range of Application	3.1
4. Scope of Supply	3.1
5. Transport and Storage	3.1
6. Mounting Instructions	6.1 - 6.7
6.1 Mounting of the Motor	
6.2 Adjustment of the motor and machine	
6.3 Electrical connection	
6.4 Preventive Action Against Electrostatic Charges	
6.5 Mounting of Speed Control Unit (SWG)	
<b>Part 2</b>	
7. Construction and Description of the EcoDrive Drive System	
8. Application	
9. Programming by the User	
10. Start of Operation	
<b>Part 3</b>	
11. Survey and List of Parameters	
12. Electrical Connections Diagram	

Technical updatings reserved !

The **CE** symbol confirms that the respective drive system meets the applicable safety requirements of the following EU directives:

- EC Maschine Directive 98/37/EG
- EMV Directive 89/336/EWG
- Low Voltage Directive 73/23/EWG

## 1. General Safety Information

This EcoDrive Sewing Drive System has been constructed and tested in compliance with the relevant regulations and safety standards and has left our factory in proper safety condition.

In order to maintain this condition and to ensure non-hazardous operation, the user is obliged to observe the information and warning notes contained in this Operating Instructions Manual.

The EcoDrive is not a ready-to-use machine, but is designed for installation into machines of the sewing-thread processing industry operating in clean and dry localities. It is not allowed to operate the EcoDrive in any machine unless the machine destined for receiving installation of this motor is specifically identified as being in compliance with the regulations of the EC Rule on machines.

Any application or use beyond the conditions stipulated above, such as outdoors, in moist or explosion hazardous environment, is not considered to be in compliance with specifications. Application in compliance with regulations and standards also includes close observation of the operating, maintenance and repair conditions stipulated by the manufacturer.

The EcoDrive can function safely and reliably only when used in compliance with this Operating Instructions Manual and in compliance with the use it is intended for.

Read this Operating Instructions Manual thoroughly before unpacking and commissioning the ECO-DRIVE. Please make yourself acquainted with all safety, installation, operating and maintenance instructions before starting operation of the EcoDrive, its accessories and attachments.

Any and all activities on and by means of the EcoDrive must be carried out exclusively under close observation of the general and specific safety instructions given in the ensuing sections of this Operating Instructions Manual!

All persons involved must be made thoroughly familiar with these safety instructions, requiring them to observe these closely. Non-observation of these safety instructions can cause injury to persons, damage to objects or malfunction of or damage to the drive system itself.

Any and all accident prevention regulations as well as the rules on work in compliance with proper practices and safety standards valid in the user country involved must be fully observed. This drive system is subject to installation and commissioning by properly trained personnel!

Installation and commissioning of the EcoDrive must be made with due care by qualified technicians so as to minimize the effects of any disturbing influences which are likely to constitute health hazards to personnel or any other perilous condition.

Doing any work on any parts or elements of the equipment being under live voltage is not permitted! Exceptions are subject to EN 50110.

Before removing any cover parts or installing any attachments or accessories - such as speed control unit, light barrier control etc. - switch the machine off, shut off physical connection with mains voltage, and wait for the machine to come to complete stop. Do not open the control box before ten minutes have elapsed!

In order to reduce any hazard of burns, fire, electrical shock, or injury, it is basically not permitted to make any structural modifications or other changes on the EcoDrive.

It is not allowed to operate the equipment with any cover or protection elements removed!

Before leaving the workplace, turn the ON/OFF switch into its OFF position. In case of prolonged pauses of operation, remove the mains plug from the wall outlet so as to safeguard the drive system against being inadvertently switched on again.

Any equipment or auxiliary facilities additionally connected to the control system of the EcoDrive are only allowed to be operated on low voltage generated by a safety transformer!

Never use the drive system with its ventilation louvers clogged. Make sure that ventilation louvers are unobstructed by fibres, lint, dust etc.

Do not introduce or drop any objects, such as needles, into the ventilation louvers.

Keep your hands out of the area of moving parts!

Do not operate the EcoDrive when using aerosols (sprays) or oxygen!

This Operating Instructions Manual is an integral part of the EcoDrive and must be passed on with it in case of change of ownership.

The instructions given in the sections below are destined for your own safety as well as for that of other persons.



Warnings given in various section of this Operating Instructions Manual for the purpose of preventing specific hazards of injury to persons or damage to the equipment are identified by the symbol shown at left.



This symbol is a warning given on the EcoDrive, indicating dangerous voltage.



The EcoDrive is permitted to operate only in a properly functional protection earth system in compliance with all local rules and regulations.

## 2. Technical Specifications

Rated Values:	ED QE3760	EDL QE5540
Voltage ( $U_N$ ) [V]	230, single phase AC	
Frequency ( $f_N$ ) [cps]	50/60	
Current (drive system) ( $I_N$ ) [A]	3,5	5,0
Current (control system) [A]	0,6	
Power (output) ( $P_2$ ) [W]	375	550
Speed ( $n_n$ ) [1/min]	6000	4000
Torque ( $M_n$ ) [Nm]	0,63	1,2
Moment of motor inertia ( $J_{mot}$ ) [kgcm <sup>2</sup> ] (without belt pulley)	0,5	1,0
Operating mode	S5 (40 % duty cycle at $t_s = 2.5$ s) Intermittent operation with electrical brake action, relative duty cycle 40 %, operating cycle time 2.5 s	
Protection type	IP40	
Insulation class	E	
Limit Values		
Range of voltage [V]	190 - 240 +/- 10% single phase	
Speed ( $n_{max}$ ) [1/min]	9000	4500
Torque (acceleration) ( $M_{max, short-time}$ ) [Nm]	3	7
Power (short-time) ( $P_{2max, short-time}$ ) [W]	1000	1500
Maximum permissible ( $J_{masch}$ ) [kg cm <sup>2</sup> ] sewing machine inertia, reduced to the motor shaft ( $J_{mach}$ )	4,5	9,0
Conditions of Use		
Ambient temperature [°C]	+ 5 bis 45	
Ambient temperature (24 hour average) [°C]	< 35	
Humidity (relative)	85% bei 30 °C	
Driving voltage of the Outputs		
Idling voltage [V]	25 DC	
Voltage under load [V]	24 DC at $I = 4$ amps (20 DC at $I = 10$ amps short-time)	
Power	96 (200, short-time)	
Load current	4	
Maximum load current	10, (short-time)	

**Note: The accumulated load currents of all simultaneously operated outputs**

## Dimensions of the Control System (small version) ED

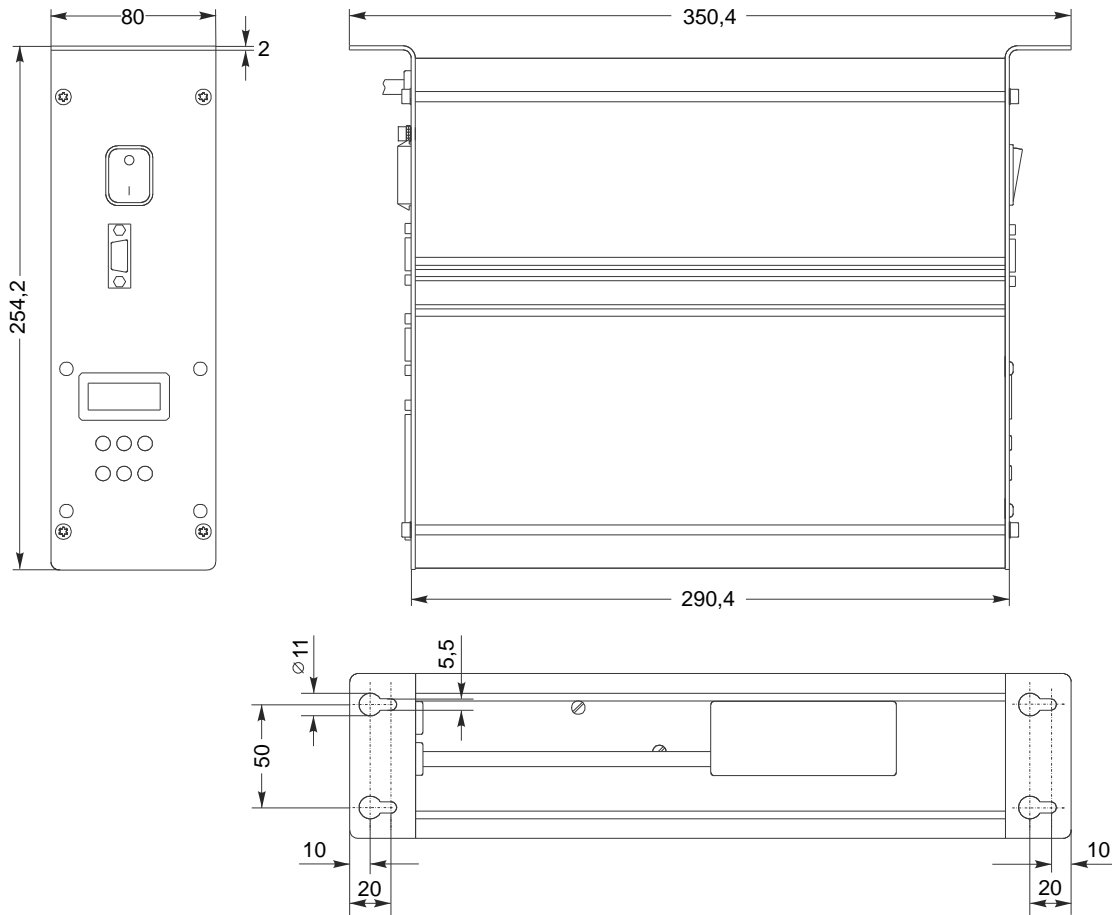

## Control System (broad version) EDx

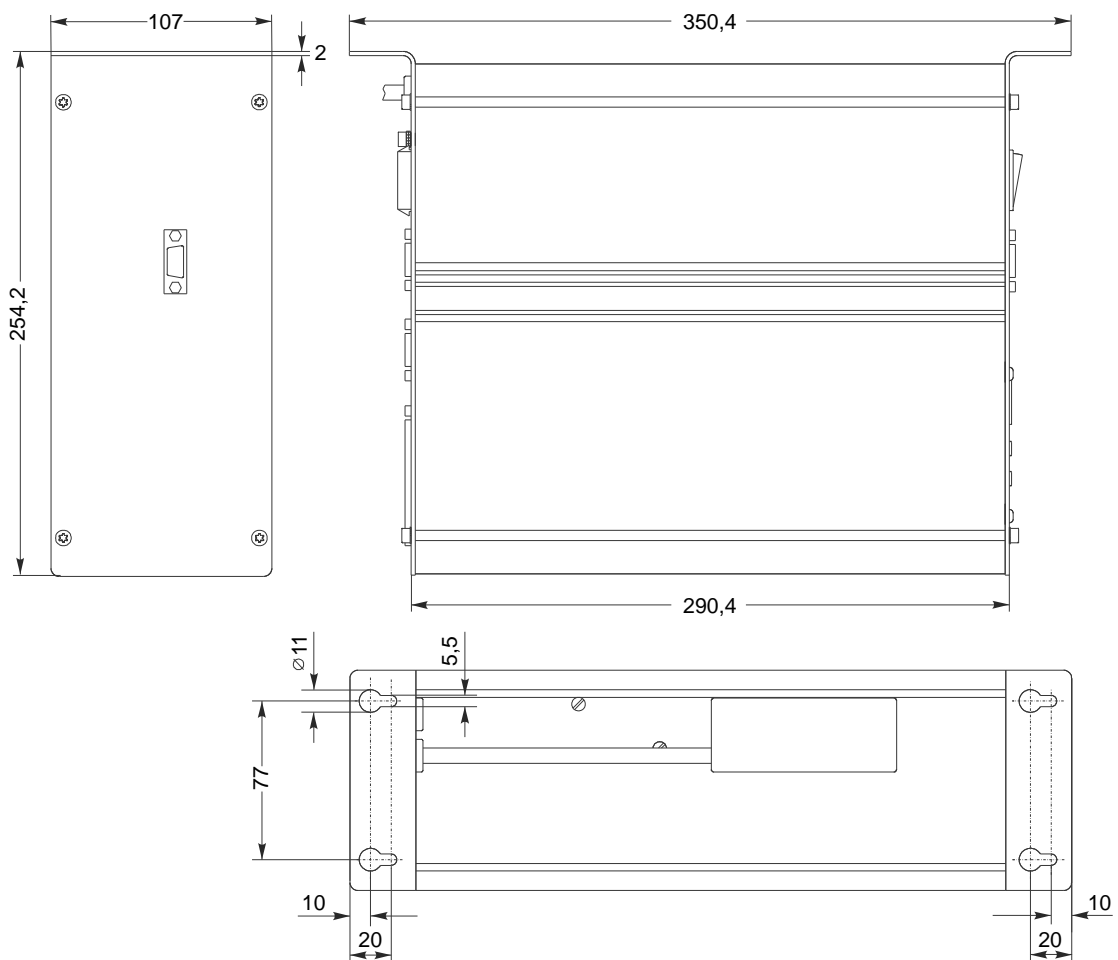

# Motor

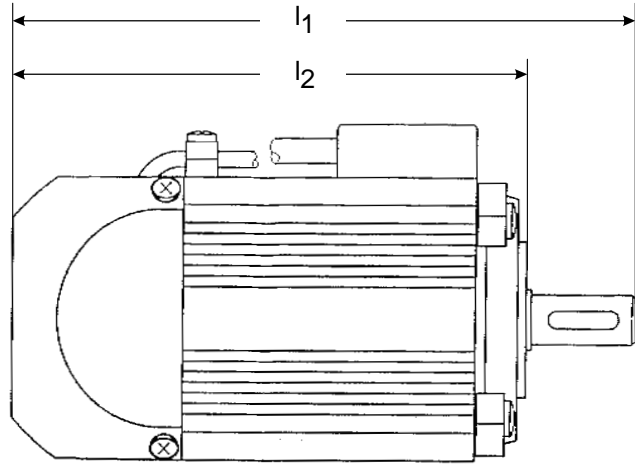
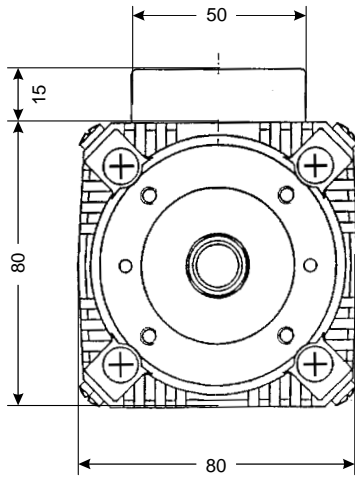

	MS	MSL
$l_1 =$	179	219
$l_2 =$	147,5	187,5

### 3. Range of Application

The EcoDrive is not a ready-to use machine, but is intended for installation into other machines, such as sewing units and sewing equipment used by the sewing thread processing industry.

The EcoDrive is destined for use in clean and dry localities.

Any application or use beyond the conditions stipulated above, such as outdoors, in moist or explosion-hazardous environment, is not considered to be in compliance with specifications.

Application in compliance with regulations and standards also includes close observation of the operating, maintenance and repair conditions stipulated by the manufacturer.

### 4. Scope of Supply

1x Synchronous motor QE3760 with commutation transmitter  
or Synchronous motor QE5540 with commutation transmitter

1x Control system with mains power switch

1x Speed control unit SWG2 (Art.Nr.63.012) + accessories

1x Operating Instructions Manual

Optional:

1 Synchronizer (Art.Nr. 62.055)

1 Operator panel EcoTop

### 5. Transport and Storage

The EcoDrive has left our factory after thorough final inspection.

Please check the drive system for any transport damages.

If necessary, file claims with the carrier.

Complaints for missing parts will be accepted within 14 days from the date of purchase.

The EcoDrive and its accessories are shipped in a carton with polyurethane insert;

outside dimensions:     L = 600 mm,  
                                  W = 405 mm  
                                  H = 280 mm

This packing material protects the EcoDrive against outside influences during transport and storage.

The EcoDrive is designed to withstand temperatures during transport and storage of between -25°C and +55°C and briefly, but not longer than 24 hours, up to +70°C.

Storage in the packing material must be in a dry environment.

**Handle the carton and its contents with care!**



## 6. Mounting Instructions

Before starting installation, please remove all parts from the packing material. The carton holds the EcoDrive, accessories and Operating Instruction manual. Check the content if complete.

If you have any questions with the installation, not clarified through the Instruction Manual, please contact us or one of our nearest Service Stations.

Assemble the EcoDrive in compliance with the instructions and illustrations.

### 6.1 Motor assembly

Es gibt drei Varianten des Anbaus des Motors an die Maschine

1. Machine head mount (rear / external)
2. Under the table top mount
3. Machine head mount (direct drive, internal)

There are three different ways to transmit the motor drive:

- Timing belt and timing gears.
- "V" belt and pulley.
- Direct drive on main shaft.

#### 6.1.1 Use of timing belt.

Transmitting torque through timing belt, slippage is avoided. Transmission ratio between motor and machine is 1:1. Being so, no reference signal from sewing machine is required. Many transmission ratios in both directions are possible, on the available timing belt wheels. In this case a reference position signal is needed by the machine.

#### 6.1.2 Use of "V" belt

Transmitting torque through "V" belt, slippage is possible. Transmission ratio between motor and machine is variable. Reference signal from sewing machine is required.

#### 6.1.3 Assembly of the motor to the machine head.

Following, list of parts required:

- Assembly bracket (machine type related)
- Motor timing gear
- Machine timing gear
- Timing belt
- Belt cover

#### 6.1.4 Assembly of the motor under the table

Following list of parts required:

- Assembly bracket
- Motor pulley
- Machine pulley
- "V" belt
- Belt cover
- If necessary synchronizer PD3
- Yadapter

## 6.2 Motor and machine adjustment

- a) Adjust motor shaft to reference position (zero position)
  - Terminal box at top (viewpoint)
  - Motor shaft groove (-90°) quarter to twelve in relation to terminal box equals zero position, rotate motor shaft.
  
- b) Adjust machine reference position (zero position)
  - Rotate machine pulley (sewing rotation) until needle point starts penetrating needle hole of throat plate (zero position)
  
- c) Assembly of timing belt
  - Slide belt to motor and machine timing gear maintain and guarantee positions described in a) and b).

## 6.3 Electrical Connection (to Mains Power)

All work on the electrical equipment (connection, maintenance, repair) is permitted to be performed only by or under the supervision of a properly qualified technician.

The EcoDrive is designed for connection to an earthed AC mains power system having a rated voltage between

190 and 260 Volts, 50/60 cps.

Before connecting the power supply line, make sure that your mains power voltage is within the rated voltage range specified on the nameplate of the EcoDrive.

Connection to mains power is permitted only by means of a multi-contact plug with protection earth contact. Fixed connection is not permitted.

Connect the following potentials:

Phase	(L1 or L2 or L3)
Neutral conductor	(N)
Protection earth	(PE)

The EcoDrive is designed for connection to the following types of mains power systems:

- TN (system with a directly earthed point and with a protection earth conductor (PE) connected to this point)
- TT (system with a directly earthed point, the protection earth conductor (PE) not being connected to this point)
- IT (system not directly earthed)

IT-Netz

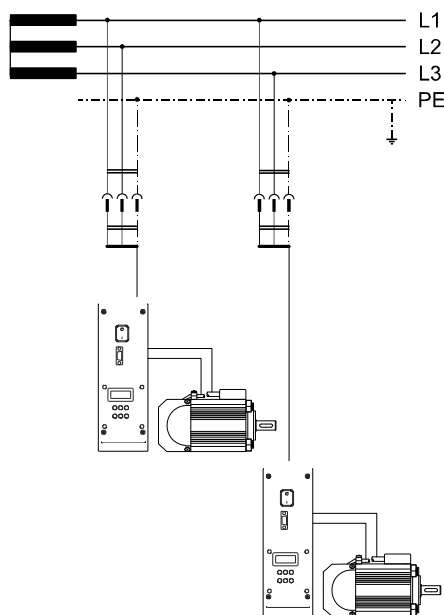

TT-Netz

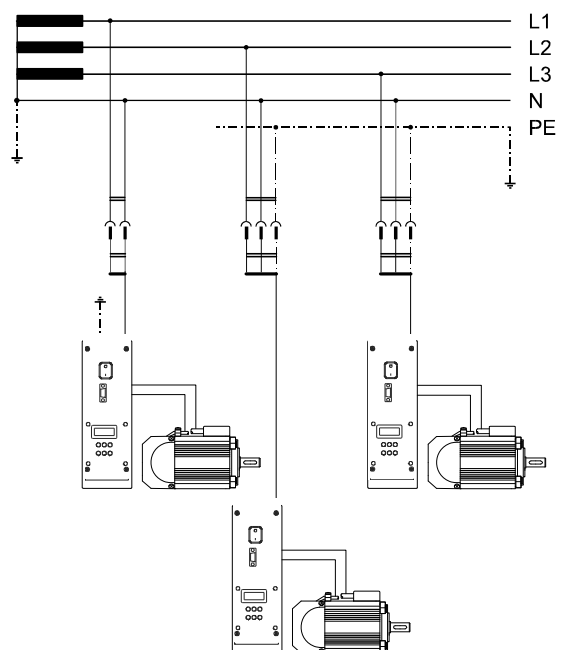

TN-Netz

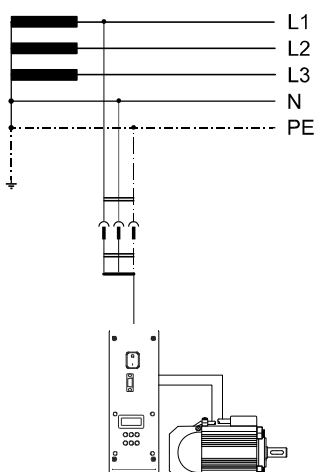

The following applies to TT and IT systems:

All elements protected by a common protective device must be connected to the same earthing via protection earth conductors.

All elements apt to be touched simultaneously must be connected to a common earthing.

The following applies additionally to IT systems::

No active conductor within the installation is permitted to be earthed directly. All elements must be connected individually, in groups, or in total with a protection earthing conductor.

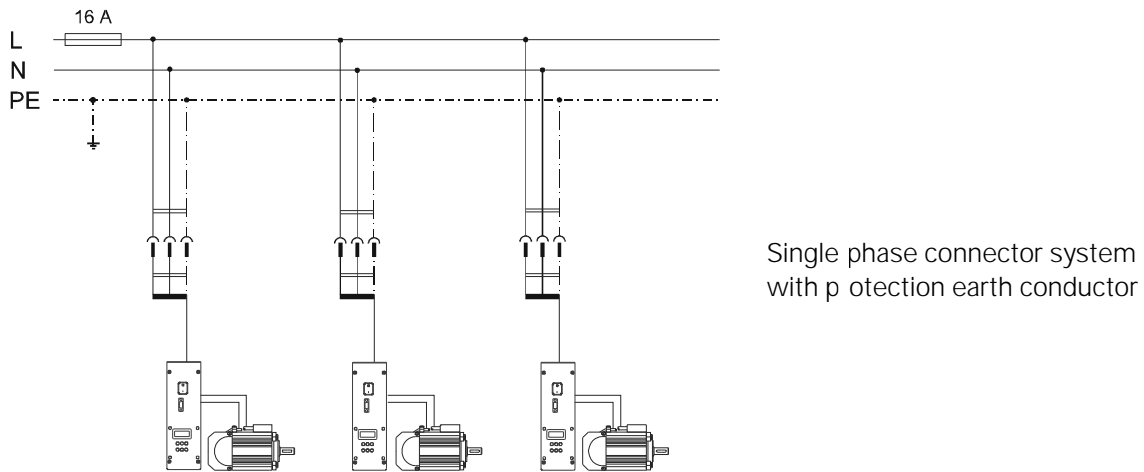

Do not operate more than 5 EcoDrives on one circuit fused with 16 amps.

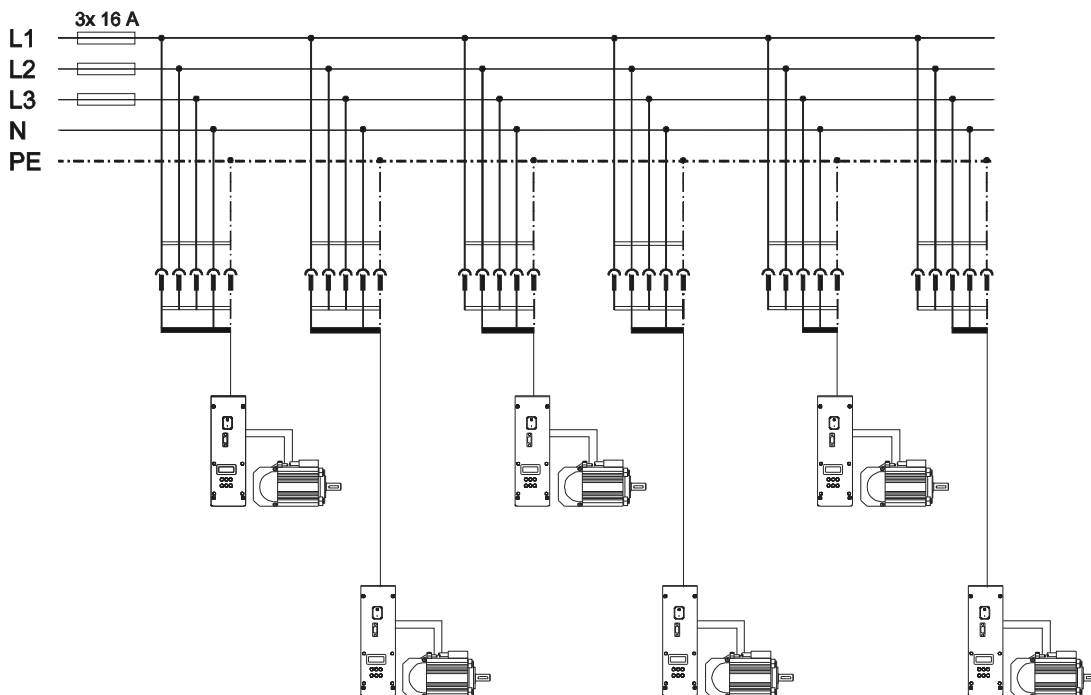

Threephase connector system with protection earth conductor

Make sure to distribute loads evenly in a three-phase AC system!  
Do not operate more than 3 EcoDrives on one face fused with 16 amps in order not to overload the N-conductor!

The EcoDrive is a protection class I device, i.e. for protection at indirect touching it comprises a protection earth connection.



The EcoDrive is permitted to operate only in a properly functional protection earth system in compliance with all local rules and regulations in order to avoid danger to persons by electric shock or fire hazards in case of malfunction.

It is not permitted to disable the protection system by using extension cables not equipped with a protection earth conductor.



**Caution:**

Any interruption of the protection earth conductor within the EcoDrive or outside, or by disconnecting the protection earth connection, can result in making the equipment hazardous.

Any intentional interruption is inadmissible.

**Fault Current Protection Devices**

If any EcoDrives are to be monitored via fault current protection devices, then the latter must be shock puls proof, short pulse delayed as well as suited for alternating and pulsating constant fault currents.

For connections, use line types not lighter than plastic- insulated sheathed flexible cables H05 VV. The minimum conductor cross section must be 1 mm<sup>2</sup>, with the line length not in excess of 5 m. The voltage drop in the protection earth conductor is not permitted to exceed 3.3 V at a measuring current of 10 amps.

Any lines installed must be properly protected against anticipated loads and must be properly fastened.

Place and attach lines so as to maintain a minimum distance of 25 mm relative to any moving parts.

Place lines, mains power leads and low voltage circuits at a proper distance from each other to achieve adequate separation.

For replacement make sure to use exclusively fuses of the type and current rating specified.

Any bridging-over of fuses is inadmissible and will create electrical or fire hazards.

If there is reason to presume that operation without hazards will not be possible, discontinue operation of the drive system and safeguard the equipment against inadvertant use.

Reasons to presume that operation without hazards will not be possible are as follows:

- if the drive system presents visible damage, for instance mains power connection cable,
- if the drive system fails to function,
- after lengthy storage at unfavourable conditions.

The control box may be opened only by properly qualified personnel and after having separated the drive system from mains power by pulling the plug out. (After switching the system off, wait at least 10 minutes.)

Insert and lock carefully the connectors on the control system after having checked the pin and socket configuration and the plug-in direction, to avoid malfunction.

The brake action will not be initiated when mains power supply is switched off or power failure occurs during operation of the EcoDrive.



When leaving the workplace or when doing maintenance work, separate the machine from mains power by pulling out the plug. For this, do not pull at the cable, but grip the plug and pull it out.

Before separating the EcoDrive from mains power, bring all control elements into „OFF“ or „0“ position.

## 6.4 Electro-Magnetic Compatibility (EMC)

The EcoDrive is designed for installation/attachment to EMC sewing units and equipment, i.e. it complies with the relevant EMC regulations (CDV IEC 204-3-1 44 sec 169) for a cable length of 500 mm at each input or output connector. In accordance with experience, this is adequate for sewing units.

More complicated sewing equipment may require additional action due to longer cables, unfavourable cable placement, neighbouring strong interference fields etc.

The following action can be appropriate for reducing or eliminating interference:

- The use of appropriate filters, delay units, line material or line placement.
- Lines belonging to different circuits (such as mains power, low voltage) being placed at a proper distance from each other to minimize interference.
- Reference potential conductors for the circuits, or a common connection point: star-type wiring with one or more reference points earthed via insulated conductors having a large cross section.
- Electrically conductive parts of the sewing unit or equipment should be connected via potential compensation leads to the protection earth conductor on the EcoDrive control box. (Use leads suited for high frequencies: fine-gauge stranded leads with a cross section of at least 2.5 mm<sup>2</sup>, or large-area copper bands.)  
When connecting potential compensation leads, make sure to achieve good contact, i.e. use toothed washers for connections to painted parts.

Include the following parts in potential compensation:

- sewing machine head
- sewing machine stand
- treadle
- housings of solenoids or solenoid valves
- holding brackets for push-button switches
- stands for stackers, band feeders etc.
- Mass Connections  
Lead mass connection lines from each equipment element to a common point.  
Use large cross section braided leads between moving parts and casings while keeping mass connection as short as possible.
- Signal Transmission  
Use electrostatic and magnetic screening, twisted conductors and appropriate line placement to ensure that transmission of interference voltages from control or mains power lines to signal lines is prevented.  
(Right-angle line crossings are better than any lower angles; by all means avoid parallel placement.)
- Separation of Equipment Parts  
Equipment parts that are susceptible to interference parts (pulse-processing and/or low-level subassemblies) should be mounted separately from and/or be screened against switching devices such as electromagnetic relays, thyristors etc.
- Although being largely unsusceptible to interference, the EcoDrive should not be operated in the immediate vicinity of HF welding devices or similar equipment to avoid malfunction.
- The EcoDrive is capable of complying with EMC regulations only when the control box front is provided with its cover!
- The covers of the control box must remain closed during operation in order to avoid malfunction due to EMC causes as well as pollution by dust penetration.

Whenever trouble should occur, please contact the manufacturer.

## 6.5 Mounting of the Speed Control Unit (SWG)

- Attach the speed control unit by means of the mounting bracket under the machine table.
- Connect the push/pull bar of the SWG with the machine treadle by means of a pitman rod.
- Install the mounting bracket for the SWG in such a way that the pitman rod and the push/pull bar of the speed control unit (SWG) line up to the treadle.  
This guarantees a optimal force transmission from treadle to SWG.
- The pitman rod and the treadle should form an angle as close to 90 degrees as possible.
- The speed control unit can be swivelled on the control box within a range of 40 degrees.
- Make sure that the treadle can move with ease!



**Europäische Union**  
Wachstum durch Innovation – EFRE

## PFAFF Industriesysteme und Maschinen AG

Hans-Geiger-Str. 12 - IG Nord  
D-67661 Kaiserslautern

Phone: +49-631 200-0  
Fax: +49-631 17202  
E-mail: [info@pfaff-industrial.com](mailto:info@pfaff-industrial.com)

### Hotlines:

Technical service: +49-175/2243-101  
Application consultancy: +49-175/2243-102  
Spare-parts hotline: +49-175/2243-103