

Preface and General Safety Information

Description of proper use or proper application

Part 1: Operating Instructions Cl. 195

1. Product Description	5
1.1 Short Description and Proper Use	5
1.2 Sub-Classes	5
1.3 Technical Specification	6
1.4 Optional Equipment	6
2. Operating Elements and Their Function	7
2.1 Elements at the Sewing Head	7
2.2 Elements on the Frame	11
3. Operating the Sewing Machine	13
3.1 Threading the Needle Thread	13
3.2 Needle Thread Quantity for Sure Stitch Formation	14
3.3 Threading the Bobbin Thread	15
3.4 Setting the Thread Tensions	16
3.5 Setting the Bobbin Thread Take-Up	17
3.6 Setting the Pressure Foot Stroke	18
3.7 Edge trimmer shut-on and shut-off	19
4. Maintenance	20

Following Patents and Registered Utility Models apply:

Status April 1994

DE 30 43 141

JP 1 258 920

IT 209 238

JP 1 339 944

KR 24 686

JP 1 803 181

TW 31 498

JP 1 931 464

US 4 116 145

US 4 446 803



1. Product Description

1.1 Short Description and Proper Use

The special sewing machine 195 is a single needle-double chain stitch machine with lower transport and an upper transport with alternating pressure feet. The hook of the 195 is set crosswise to the direction of sewing (Crossline). With the parts set 195 5002 it can be converted to a two-needle sewing machine.

The machines are designed and may only be used for sewing materials of textile fiber and leather.

As of 11/95 Class 195-171110 is equipped at the factory so that thread thicknesses greater than 25/3 Nm can be sewn (airbag production). For this, the machine and the parts kit 195 5002 each have a second hook, this means that:

The **single needle machine** can be equipped with

hook 195 4753 for threads up to 25/3 Nm or with
hook 195 4753a for threads thicker than 25/3 Nm as required.

The **dual needle machine** can be equipped with the

hooks 195 4753 and 195 5055 for threads up to 25/3 Nm or with
hooks 195 4753a and 195 5055a for threads thicker than 25/3 Nm as required.

Attention!

The hook or hooks not inserted in the machine are enclosed with the machine.

1.2 Sub-Classes

195-171110

Execution without thread trimmer.
Electropneumatic lifting of the
pressure foot

195-171521

Execution with electropneumatic
thread trimmer for needle and
bobbin thread, electropneumatic
automatic interlock and
pressure foot stroke



1.3 Technical Specification

Needle system:	933
Maximum number of stitches:	4000 rpm dependent on pressure foot stroke and stitch length
Maximum stitch length:	Upper transport 10 mm Lower transport 8 mm
Maximaler pressure foot stroke:	2-7 mm
Clearance under the pressure feet:	
when sewing:	10 mm
when raised:	17 mm
Maximum thread thickness:	20/3 Nm
Operating pressure:	6 +/- 0,5 bar
Line pressure:	7-10 bar
Air consumption per work cycle:	
-171110	0,05 NI
-171521	0,1 NI
Through-feed area:	280 x 132 mm

1.4 Optional Equipment

195 5002	Parts set for converting a single-needle to a two-needle machine. Max. needle pitch 14 mm dependent on the E-Nr. Not for 195-171521.
Z 133 601	Reflecting light barrier for recognizing the seam end.
Z 132 1501	Needle cooling from above.



2. Operating Elements and Their Function

2.1 Elements on the Sewing Head

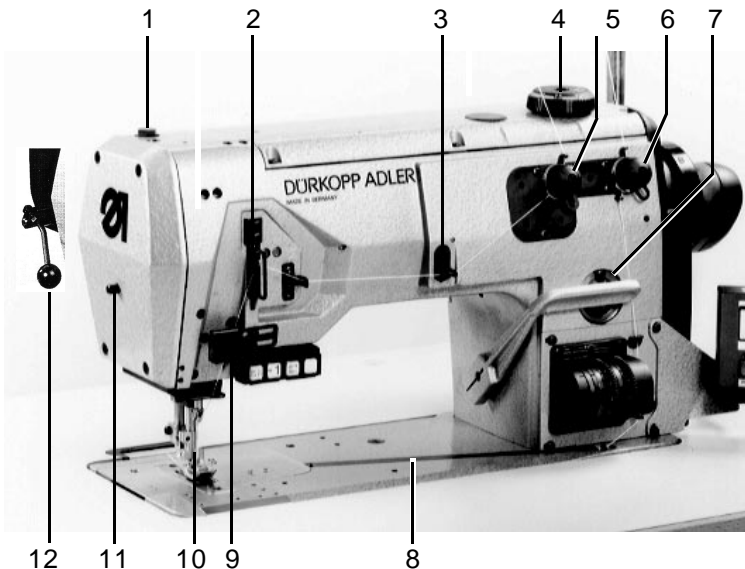

Element	Function
1 - Screw	- This screw for the pressure foot pressure is screwed in completely at the factory. Do not alter the screw position!
2 - Thread regulator	- Setting the correct needle thread quantity
3 - Needle thread puller	- For formation clean stitches at the beginning of the seam pull out sufficient thread.
4 - Adjustment wheel	- Setting pressure foot stroke.
5 - Control knob	- Setting needle thread tension.
6 - Control knob	- Setting bobbin thread tension.
7 - Viewing glass with fill opening	- Show the oil level in the reservoir. The oil level must be kept above "MIN". If necessary fill "Esso SP NK 10" oil up to the "MAX" marking.
8 - Plate	- Bobbin thread guide
9 - Light barrier	- Recognition of the material edge and thereby the precise position of the stitch condensation at the seam end.
10 - Needle	- 933, Needle thicknesses depending on the sewing arrangement. Caution Risk of Injury!
11 - Knob	- Lock the pressure foot in the raised position.
12 - Lever	- Edge trimmer shut-on and shut-off. (195-671110)

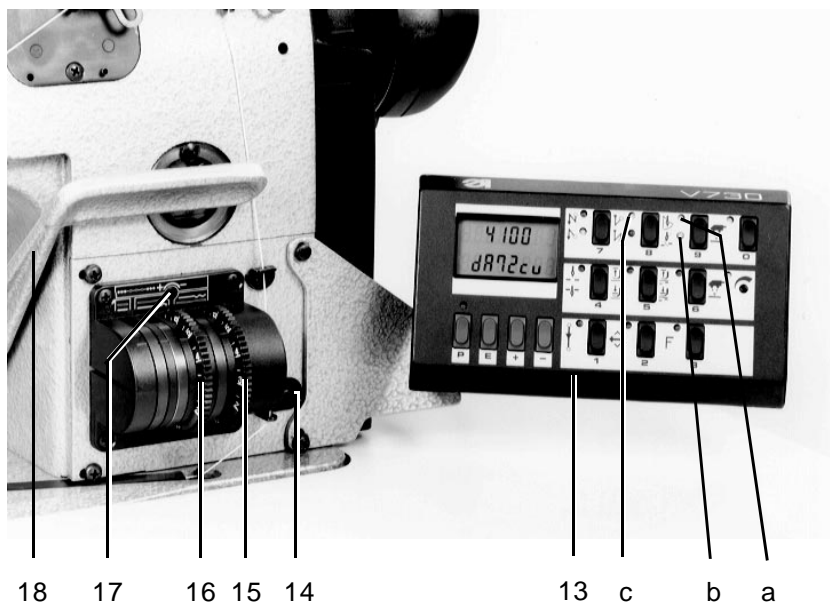

Element	Function
13 - Operating field	- See motor manufacturer's instructions Note: For thread trimming with the sub-class 171521 the thread wiper on the thread trimming key must also always be turned on. Diodes a and b must be lit. The upper diode c must be lit on the "Stitch Condensation at the Seam End" key.
14 - Bobbin thread-puller	- For formation a clean stitch at the seam beginning pull out sufficient thread.
15 - Adjustment wheel	- Setting the stitch length of the upper transport.
16 - Adjustment wheel	- Setting the stitch length of the lower transport.
17 - Screw	- Setting the stitch condensation (Length of the stitches).
18 - Hand lever	- Continuous adjustment of the stitch length.

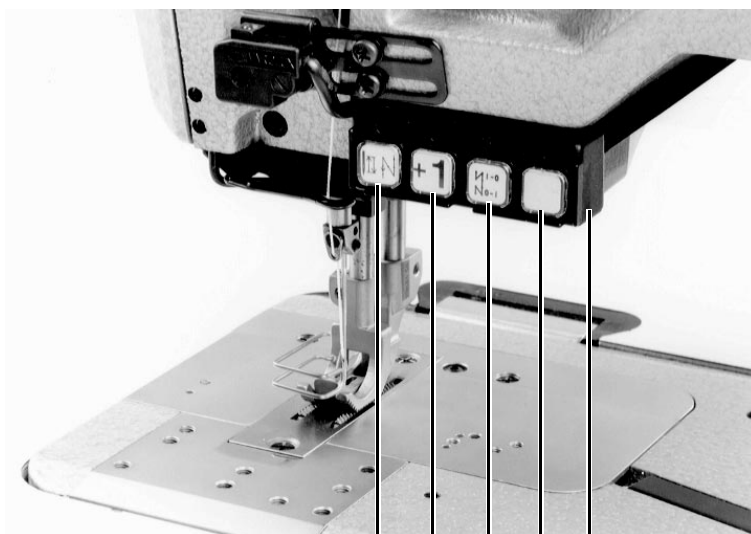

20 19 18 17 16

Element	Function
16 - Block of Keys	
17 - Key	- Key not just.
18 - Key	- Suppression of stitch condensation at seam beginning
19 - Key	- Sew single stitches
20 - Key	- Bring the needle alternatingly in position high/low, stitch condensation at any desired seam position during sewing.



Element	Function
---------	----------

- | | |
|----------------|--|
| 20 - Dip stick | - Measuring the oil level in the hook drive housing . Dip stick is in the enclosed package. |
| 21 - Screw | To check the oil level screw out screw 21 and place the dip stick 20 in the opening. The oil level must be between the markings. Fill only Esso SP NK 10-type oil. |



Attention!

When overfilling the excess oil will come out of the ventilation hole in screw 21.

- | | |
|---------------------|---|
| 22 - Thread take-up | - Automatic adaption of the bobbin thread quantity to the set stitch length. Settings for tight, normal and highly elastic seams see Section 3.5. |
|---------------------|---|

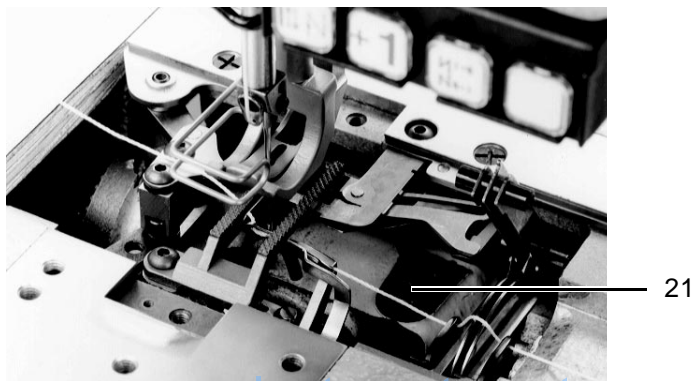
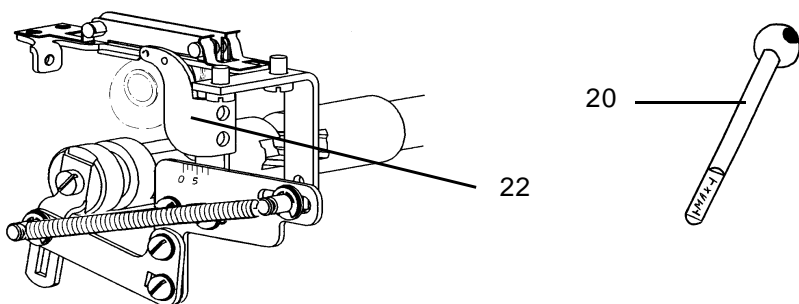



2.2 Elements on the Frame

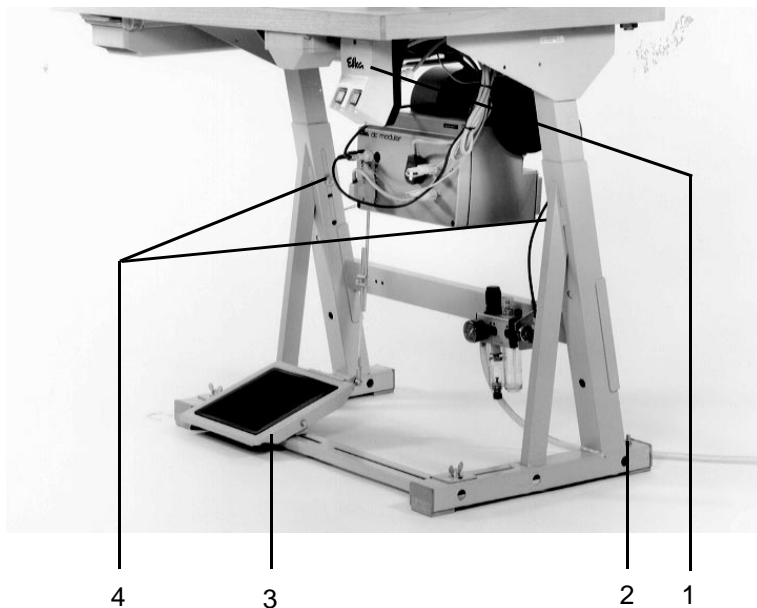

Element

Function

1 - Main switch	- Switch the machine on and off.
2 - Screw	- Compensation for floor irregularities
3 - Pedal	
Rest position	- No function
Position forward	- Sewing with desired rpm
Position "half back"	- Raise pressure foot when machine at rest
Position "full back"	- Thread trimming and raise pressure foot
4 - Screws	- Adjusting the work height



Maintenance Unit

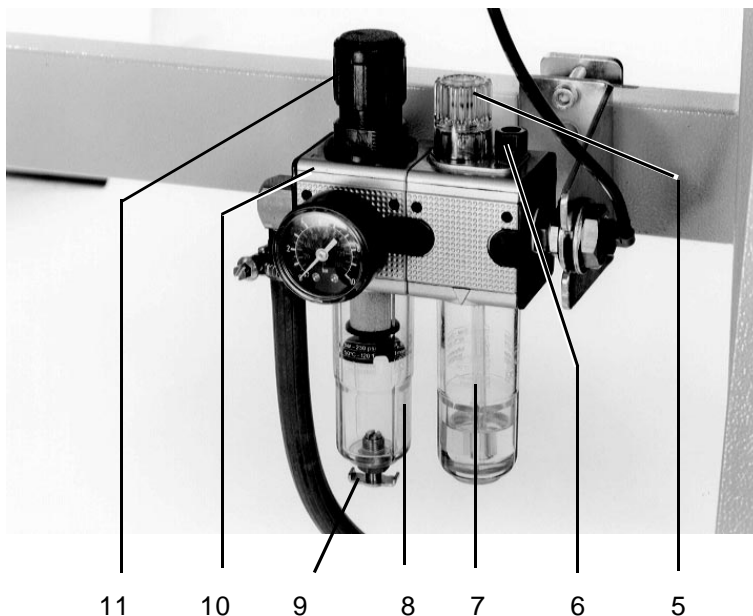

Element	Function
7 - Oil mister	- With the regulating screw 5 set approx. 1 drop for 10 work cycles. To fill interrupt the compressed air feed and vent the system with screw 9. Screw out screw 6 and fill "Esso SP NK 10"-type oil up to the groove in the glass.
8 - Air filter and water trap	- Before the water level reaches the filter, screw in screw 9 far enough to drain water. Do not interrupt the compressed air supply.
10 - Pressure Regulator	- To set to 6 bar pull the bushing 11 up and turn appropriately.

www.promelectroavtomat.ru



3. Operating the Sewing Machine

3.1 Threading the Needle Thread

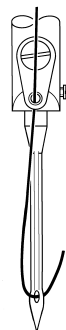
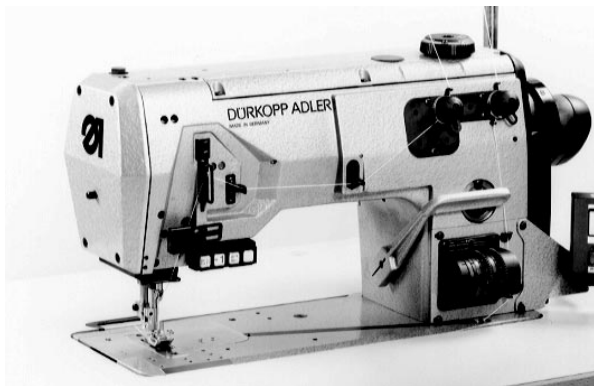
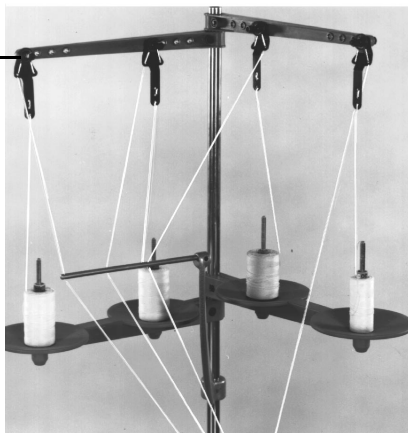
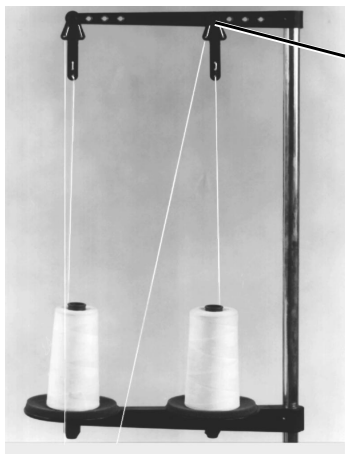

Caution Risk of Injury!

Turn off main switch before threading.

- Thread the needle thread as shown in the illustrations.

Important!

By machines with thread trimming it is essential that the needle thread be threaded through the pre-tensioners (1).



3.2 Needle Thread Quantity for Sure Stitch Formation

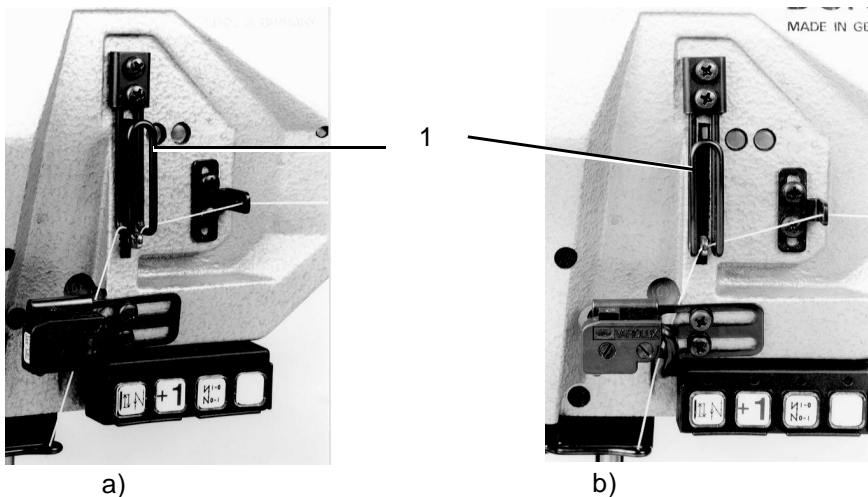

With elastic sewing threads, e.g. synthetic fiber threads, a certain needle thread quantity must be pulled out for sure stitch formation.

This occurs in the low position of the take-up lever in conjunction with the thread regulator 1.

For this the thread regulator is set as follows:

- Bring the thread regulator into its lowest position.
- Adjust the thread regulator.

With elastic threads:

The thread hole must be visible below the thread regulator.

Thread the needle to the **left** past the bar. Illus. a

With non-elastic threads, e.g. cotton:

Thread hole should be visible above the thread regulator.

Thread the needle thread to the **right** past the bar. Illus. b



3.3 Threading the Bobbin Thread

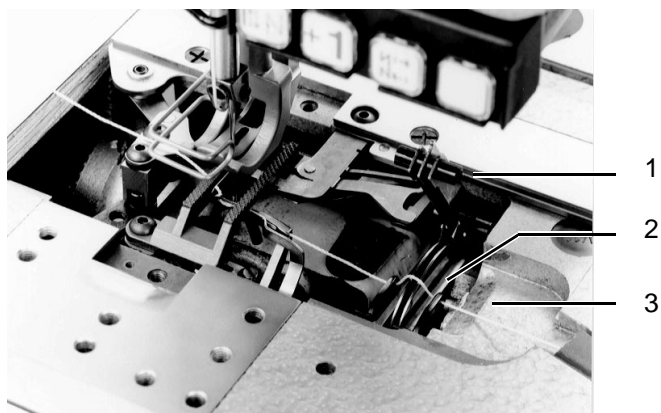

Caution Risk of Injury !

Turn off the main switch before threading.

- Lift the thread holder 1 out of its catch.
- Draw the thread through the holes 2 and 3.
- Draw the thread through the hook holes.
- Close the hook holder.



3.4 Setting the Thread Tensions

The thread tension of the needle thread must be higher than that of the bobbin thread. The control knob for the bobbin thread tension thus has a spring of thinner wire.

Too high thread tensions cause a puckering of the material.

Too low bobbin thread tensions can cause faulty stitches.

For setting a greater thread quantity in the seam see Section 3.5.

Furthermore, one can work with or without pneumatic tension opening during the stroke of the sewing foot.

The tension opening is necessary when the sewing material with thread is to be pulled forward under the sewing foot. Here the arm cover must be removed and the coupling plug inserted into the preattached coupling socket.

Attention!

When sewing corners with sewing foot stroke a loose stitch results. Thus, pneumatic tension opening should only be used when there is no sewing foot stroke during the course of the seam.



3.5 Setting the Hook Thread Take-up

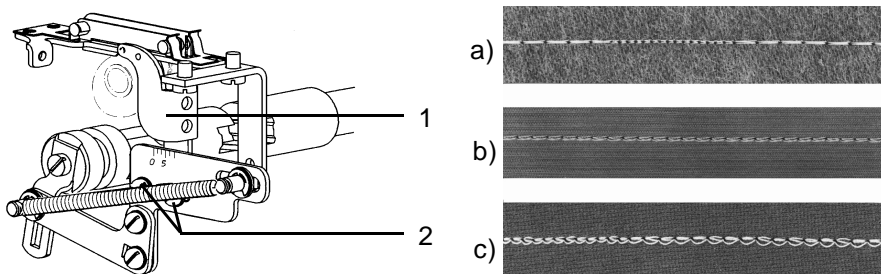

The thread take-up 1 provides for an automatic adjustment of the thread quantity to the set stitch length.

Because of this, stitch pull and stitch formation are always optimal for every stitch length, also for stitch condensation. The drawn-in thread quantities can be altered for each type of seam.

Results without altering the thread tensions are:

- a) tight
- b) normal
- c) highly elastic (ballon stitch) seams.

- Loosen screws 2.
- Adjust the thread take-up.
Direction 0 tighter seam
Direction 5 elastic seam.

Important!

1) With extreme settings, e.g. a smallest possible stitch length and a highest possible thread quantity (elastic seam), care must be taken that a positive stitch of the needle into the thread delta is possible. Faulty stitches can occur by too large hook thread quantities.

2) If the stitch length is greatly increased by the settings described under 1, it is necessary to set back the thread guide in the direction 0. Otherwise the hook thread may jump off of the thread take-up disc.



3.6 Setting the Pressure Foot Stroke



Attention!

The machine does not have automatic revolution reduction. When sewing with a large pressure foot stroke it is imperative to manually reduce the number of revolutions.

Too high revolutions become obvious through louder sewing noise.



3.7 Edge trimmer activating and deactivating

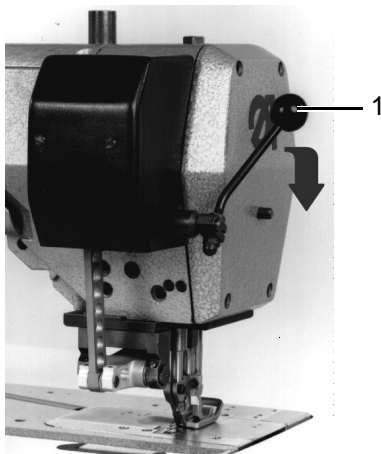

The edge trimmer off CI. 195-671110 may be actuated at any time. It's upper knife is such as formed that also a save cutting aktion is achieved at activating while sewing.



Attention Danger of injuring

Don't reach into cutting zone at activating the trimmer. Remove finger guard only for repair aktions. immediately replace finger guard at damages.

For activating of the trimmer pull lever 1 downwardly, for deactivating push lever upwardly



4. Maintenance



Caution Risk of Injury !

Turn off the main switch before cleaning the machine.

At the very latest maintenance work must be conducted after the number of operating hours listed in the column " Interval". Shorter maintenance intervals may necessary when working with very linty material.

Procedure	Interval	Remarks	
Head			
Removal of lint accumulations	8	Particularly at following points: Underside of the stitch plate Transporter stays Area around the hook	
Check oil level in the reservoir	40	See Subject 2.1 Element 10	
Maintenance Unit			
Clean insert in the air filter	8	500	First vent the system
Check oil level in the oil mister	6	180	Do not allow the oil level to fall the opening in the suction pipe
Check the oil feed in the oil mister	180	See Subject 2.2	
Check all compressed air lines for leaks	500		