

Service Manual

Model. SCM-269 series

Sewmaster Industrial Co., Ltd.

Satimaco Industries Co., Ltd.

(Sewing machine of rotary hook)

1.Presser bar	_____	P.1
2.Needle depth	_____	P.2
3.Needle position	_____	P.3
4.Feed dog (position)	_____	P.4
5.Timing	_____	P.5
6.Distance between needle & shuttle race	_____	P.6
7.Postion of bobbin	_____	P.7
8.Tension dial	_____	P.8
9.Tension of bobbin case	_____	P.9
10.Auto threader	_____	P.10
11.Open external cover	_____	P.11
12.Adjust the starting point	_____	P.12
13.Electronic parts & circuit board position	_____	P.13
14.Circuit cord connection	_____	P.14
15.Change Y shaft puise motor (regulated motor)	_____	P.15
16.BH motion switch adjust	_____	P.16

1. PRESSER BAR

TOOL: 2.0mm hexagon screwdriver, 6.0mm gauge.

STANDARD: Height of presser foot-6.0mm.

- A. Open face cover.
- B. Lift presser bar lifter to upper position.
- C. Loosen hexagon screw (A) of presser bar guide bracket.
- D. Adjust presser bar until presser foot lifting height is 6.0mm
- E. Tighten hexagon screw.(A)

CHECK:

Repeat the presser bar lifter down & up for confirm the height of presser foot is 6.0mm.

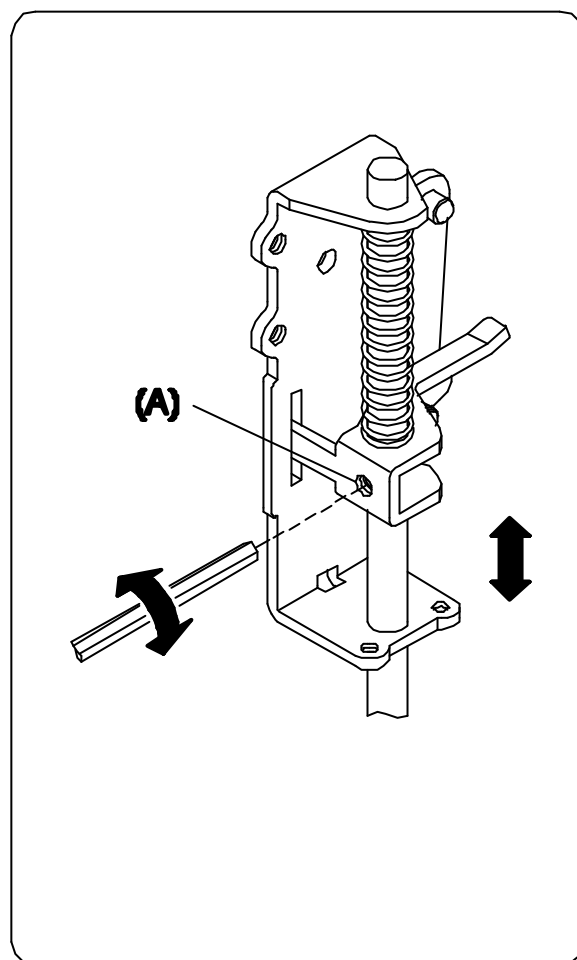
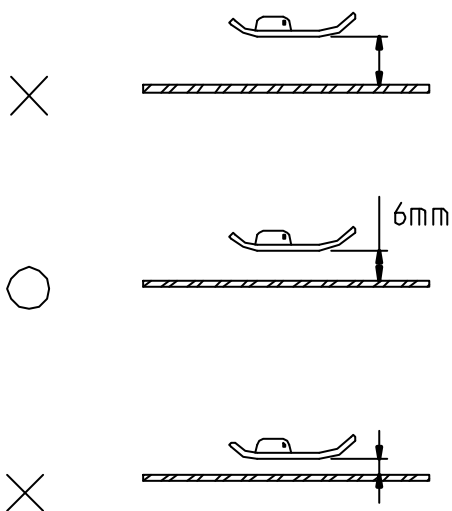

2.NEEDLE DEPTH

TOOL: 2.0mm hexagon screwdriver, "—" type screwdriver (large)

STANDARD: Sharp of needle touch with bottom of shuttle race related.

NOTE: Needle must be at the deepest of the hole, tighten the presser foot thumbscrew for fix the needle in needle clamp.

CHECK:

- A. Open needle plate, take bobbin case out.
- B. Turn the hand wheel, make needle at the bottom point.
- C. Check the distance between needle and the bottom of shuttle race.(see fig)

ADJUSTMENT:

- A. Loosen the hexagon screw (A) of needle bar bracket adjust to up or down until needle at correct position.
- B. Tighten the hexagon screw of needle bar bracket.

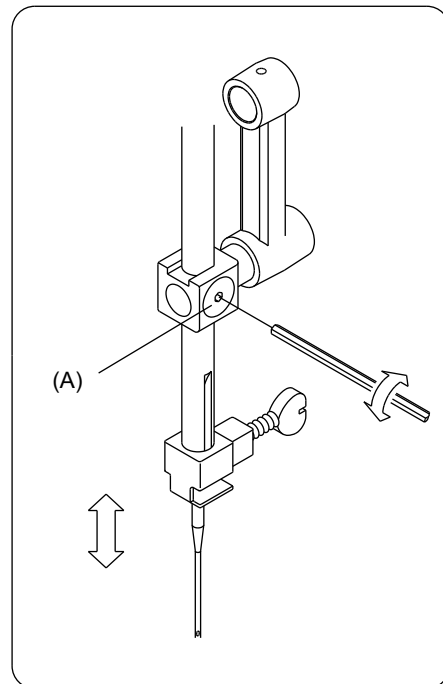
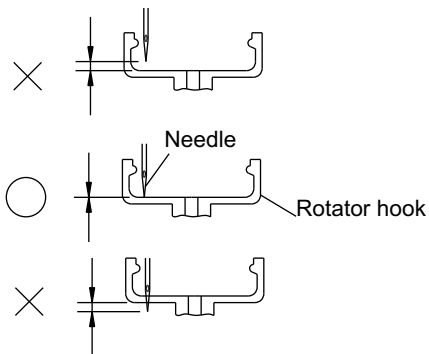
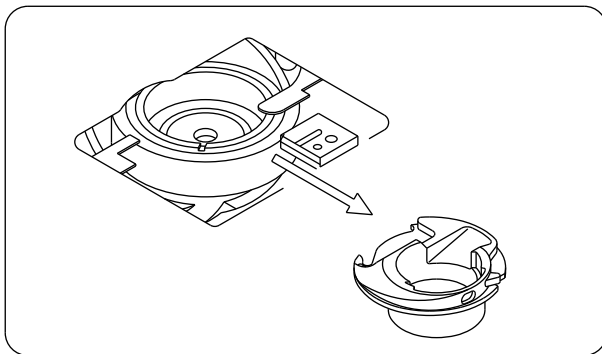
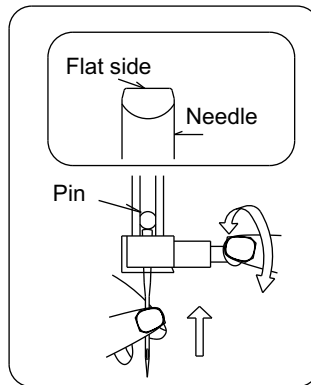
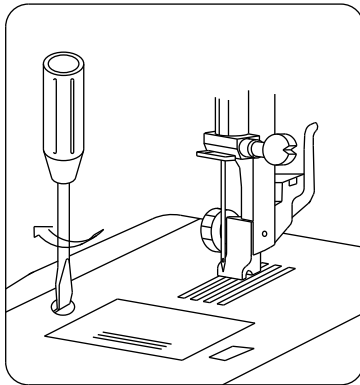

3. NEEDLE POSITION

TOOL: 2.0mm hexagon screwdriver, "_" type screwdriver (small), special tool (sleeve)

STANDARD: Between needle body with needle plate hole 0.6mm left & right side each.

ADJUSTMENT: Right position _____

CHECK:

- A. Open front cover.
- B. Move the stitch width dial to "0" position.
- C. Turn hand wheel, make needle through needle plate hole, check the distance between needle body with right side of need plate hole.

ADJUSTMENT:

- A. Use 2.0mm hexagon screwdriver, loosen the hexagon screw of needle bar crank.
- B. Use "_" type screwdriver adjust zigzag eccentric pin until the needle right position at standard position.
- C. Tighten the hexagon screw of needle bar crank.
Left position _____

ADJUSTMENT:

- A. Move the stitch width dial to "6" position. (see fig)
- B. Turn hand wheel, make needle through needle plate hole.
- C. Use "_" type screwdriver loosen a little bit of the binding head screw on zigzag regulate nut.
- D. Use sleeve adjust zigzag regulate nut.
Left needle position lean on right: Turn to left
Left needle position lean on left: Turn to right
- E. Tighten the binding head screw (B) of zigzag regulate nut.

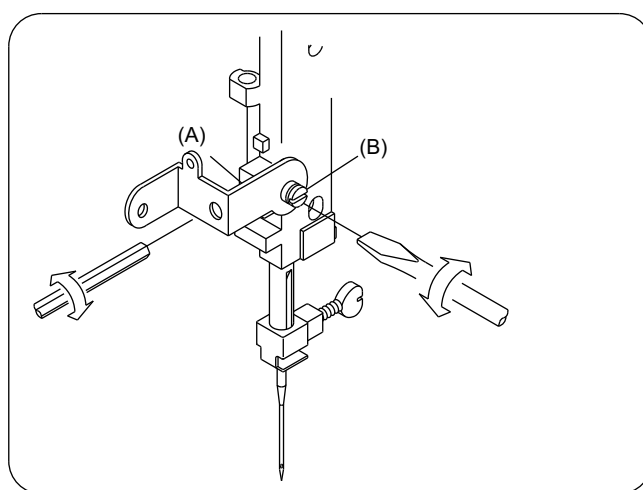
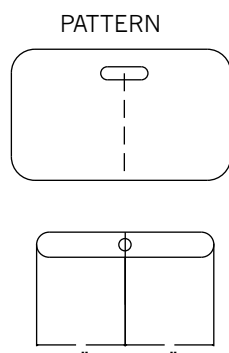

4. FEED DOG (POSITION)

TOOL: 7.0mm hexagon sleeve, "—" type screwdriver.(small)
Gauge for feed dog height.

STANDARD: Feed dog height 0.9mm (move)-1.1mm (stable).

- A. Turn hand wheel, make needle at the highest point.
- B. Open bottom cover.
- C. When feed dog lower than 0.9mm, use "—" type screwdriver, turn the screw to right, until feed dog match standard.
- D. When feed dog higher than 1.1mm, use "—" type screwdriver, turn the screw to left, until feed dog match standard.
- E. Use sleeve, tighten hexagon nut.

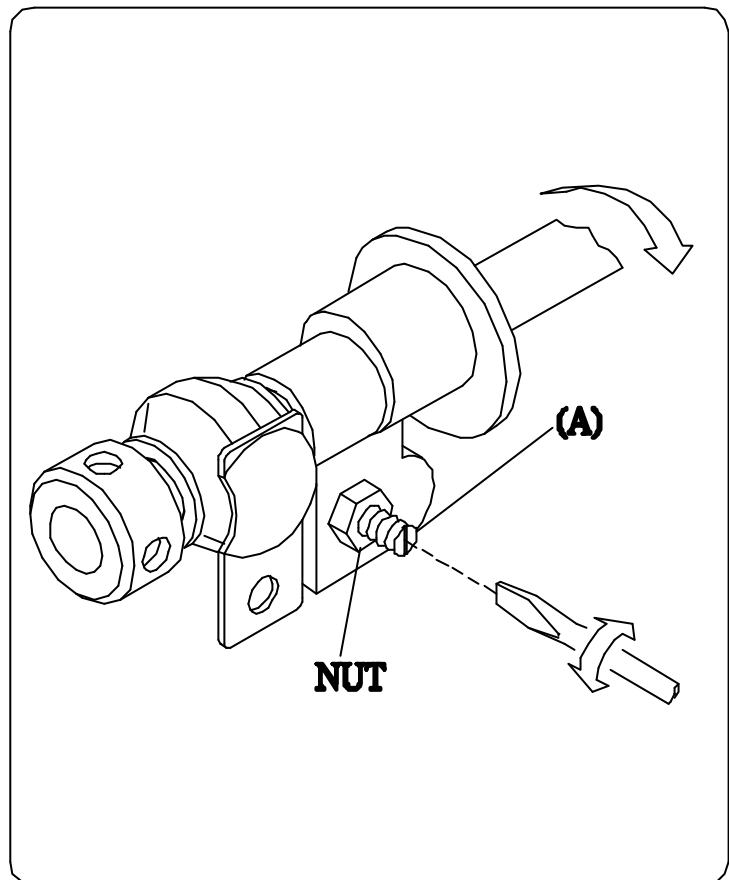
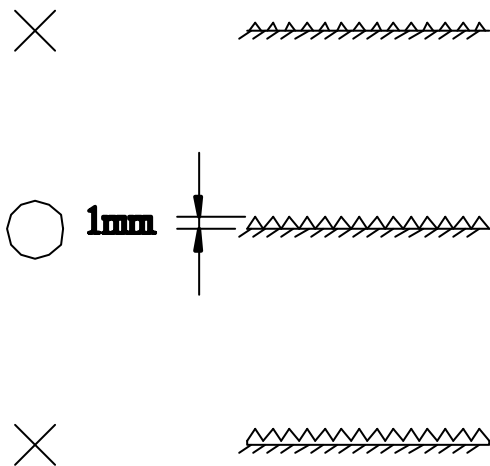

5. FEED DOG (REGULATE)

TOOL: 2.5mm hexagon screwdriver .

STANDARD: move down the needle from the highest point, feed dog transmission between 0-1mm.

ADJUSTMENT:

- A. Turn hand wheel, make needle at the highest point, check transmission of feed dog.
- B. Open bottom cover.

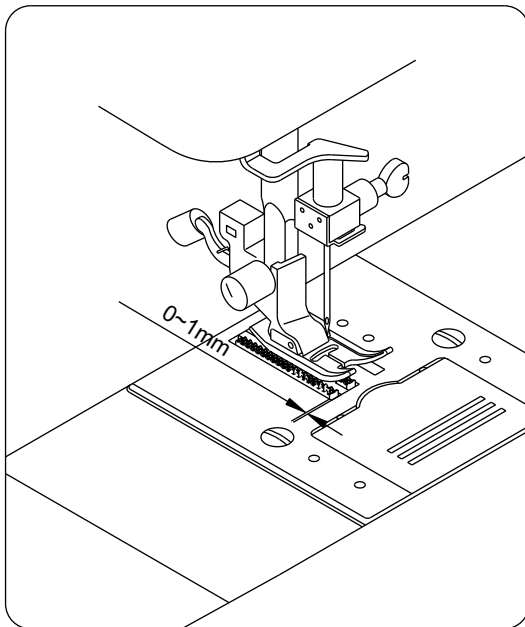

6. DISTANCE BETWEEN NEEDLE & SHUTTLE RACE

TOOL: 2.0mm hexagon screwdriver

STANDARD: The distance between needles and shuttle race sharp
0.01mm-0.015mm.

CHECK:

Move the stitch width dial to "3" position. (middle position)

ADJUSTMENT:

- A. Open face cover.
- B. Use 2.0mm hexagon screwdriver, loosen the hexagon screw (A) of arm.
- C. When distance too close, move needle bar crank support shaft back until the distance correct.
- D. When distance too far, move needle bak crank support shaft forth until the distance correct.
- E. Must be tightening the hexagon screw (A) of arm.

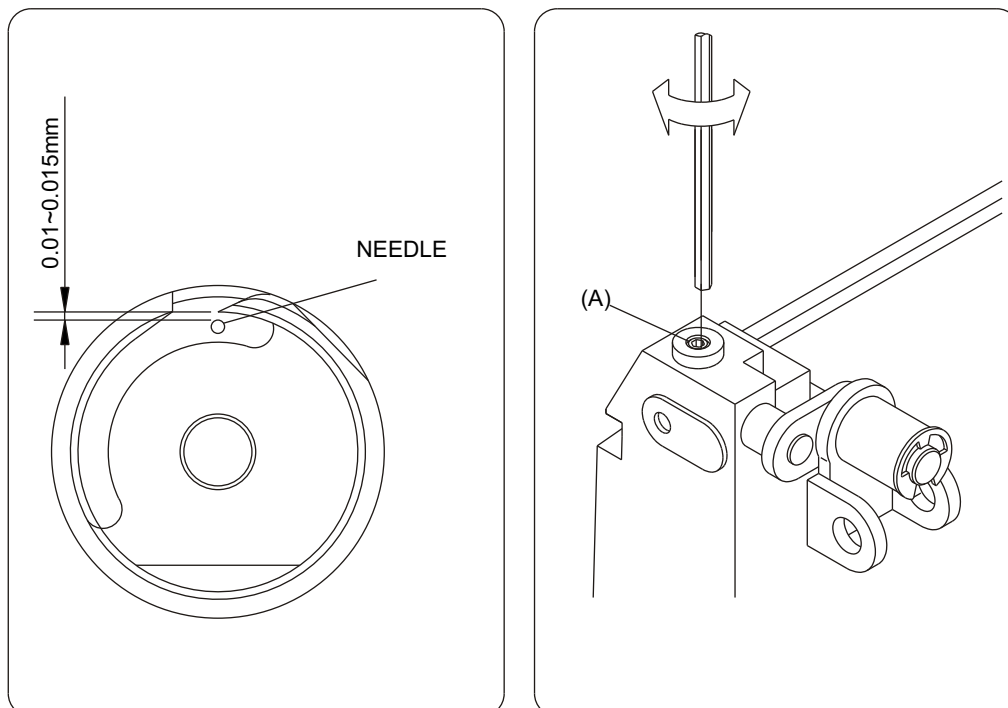

7. POSTION OF BOBBIN

TOOL: " _ " type screwdriver (large), special gauge.

STANDARD: Distance between bobbin with stop shrapnel holder 1mm.

ADJUSTMENT:

- A. Open needle plate.
- B. Loosen T screw (A) of bobbin case set stop plate.
- C. Put special gauge in the gap, set at 1.0mm
- D. When the gap less than 1.0mm, adjust bobbin case set stop plate upper.
- E. When the gap more than 1.0mm, adjust bobbin case set stop plate lower.
- F. Tighten T screw (A) bobbin case set stop plate & return needle plate.

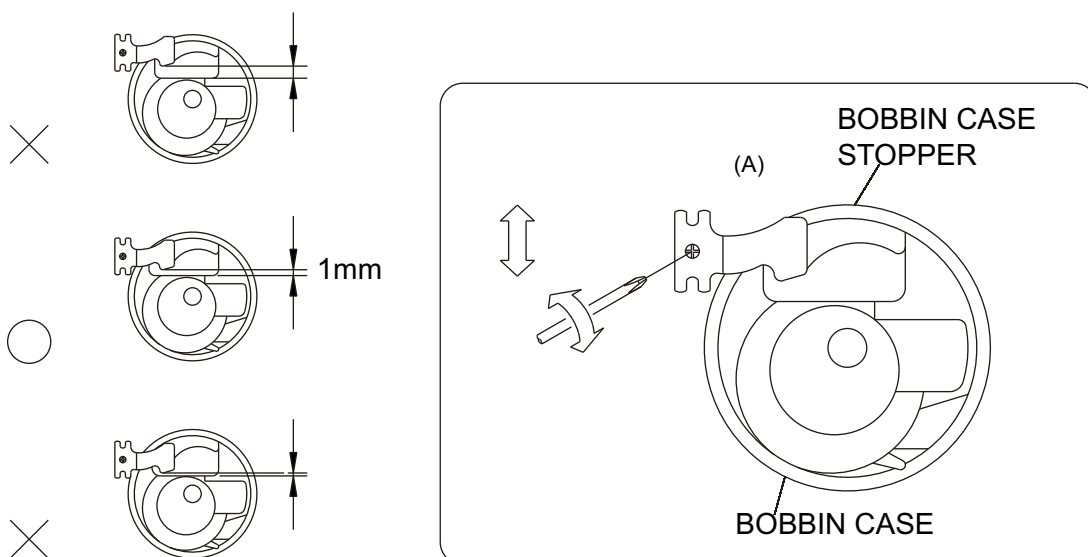

8. TENSION DIAL

TOOL: Tension gauge

STANDARD: Set D / T at "4" , tension between 60g-80g.

CHECK:

- A. Set D / T at "4".
- B. Lift presser bar lifter at upper position
- C. Threading the thread of tension gauge in D / T.
- D. Put presser bar lifter down.

ADJUSTMENT:

- A. Open front cover.
- B. When tension too tight (more than 80g), turn down the elastic regulate by finger until tension match standard.
- C. When tension too loose (less than 60g), turn up the elastic regulate by finger until tension match standard.

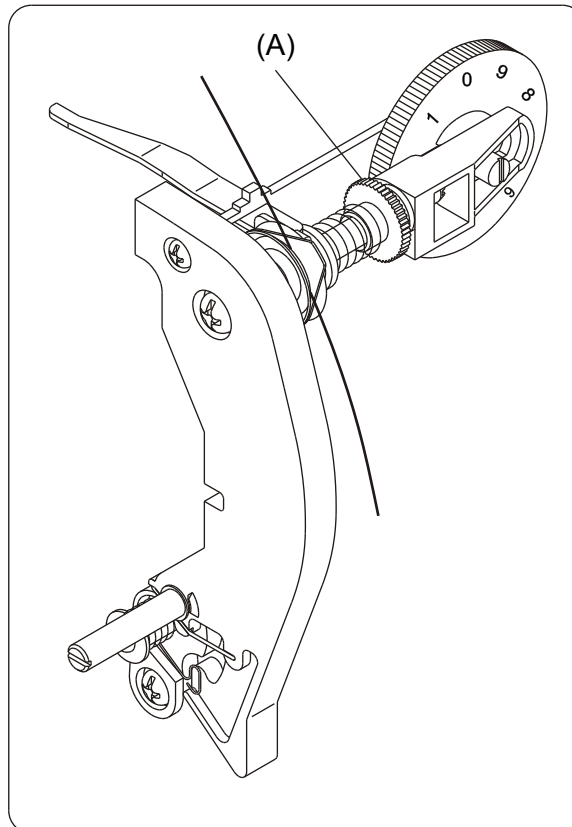

9. TENSION OF BOBBIN CASE

TOOL: Tension, " _ " type screwdriver.(small)

STANDARD: Tension between 16g-20g.

CHECK:

- A. Open needle plate, take bobbin case out.
- B. Threading to check.(see fig)

ADJUSTMENT:

- A. When tension too tight, use " _ " type screwdriver to turn the regulate screw (A) by anticlockwise until tension match standard.
- B. When tension too loose, use " _ " type screwdriver to turn the regulate screw (A) by clockwise until tension match standard.
- C. Return bobbin case & needle plate.

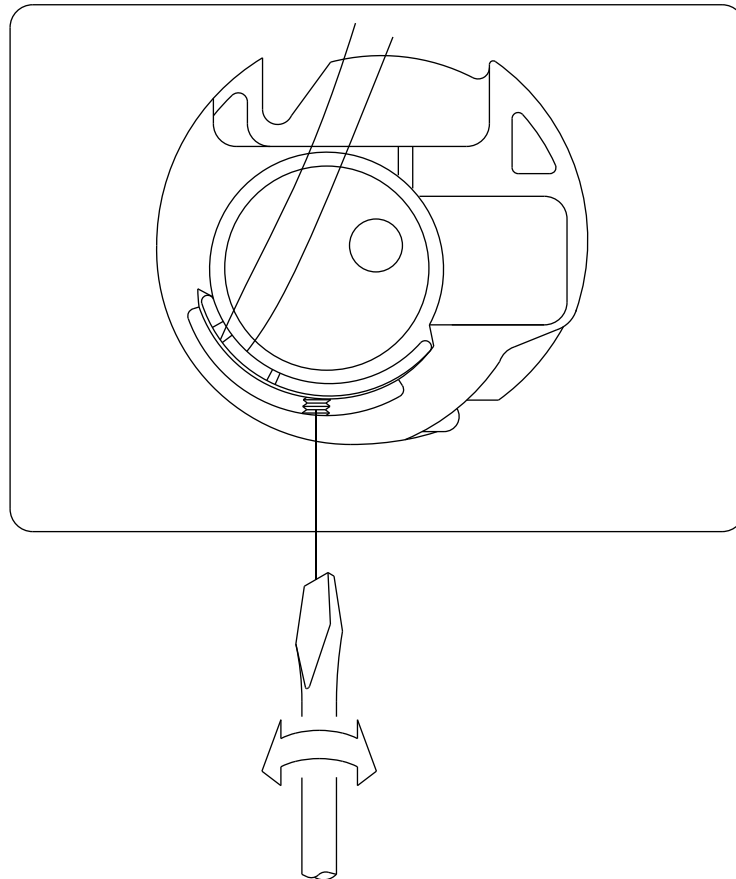

10. AUTO THREADER

TOOL: 1.5mm hexagon screwdriver, “_” type screwdriver.(large)

STANDARD: Auto threader hook thread normal.

CHECK:

- A. Turn hand wheel, make needle at highest position.
- B. Try hook thread.

ADJUSTMENT:

- A. Open face cover.
- B. Use 1.5mm hexagon screwdriver,loosen hexagon screw (A) of through thread location plate , screwdriver keep at the screw hole.
- C. When the hook of threader higher than needle hole, use the hexagon screwdriver to press down the through thread location plate until match correct position.
- D. When the hook of threader lower than needle hole , use the hexagon screwdriver to move up the through thread location plate until match correct position.
- E. Check threads motion again.
- F. Tighten the hexagon screw (A)of through thread location plate.

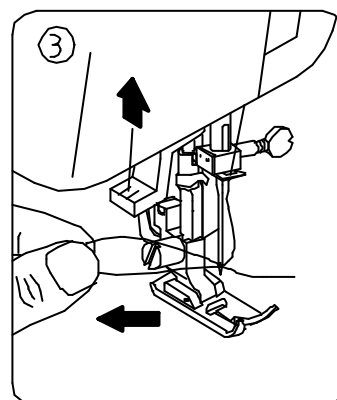
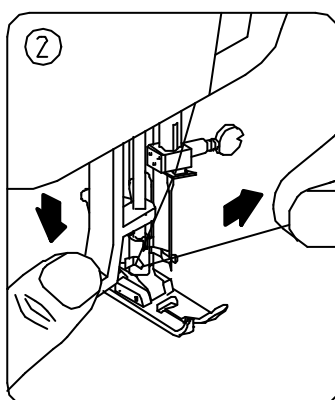
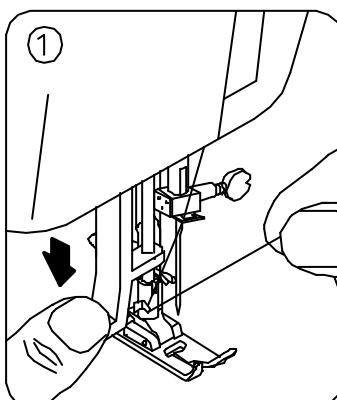
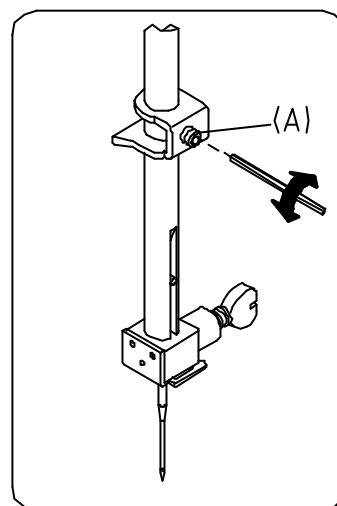

11.OPEN EXTERNAL COVER

- A. Face cover, top cover, side cover, bottom cover each open & assemble separate.
- B. Before open front cover , open other parts firstly as face cover, top cover, side cover, & bottom cover.

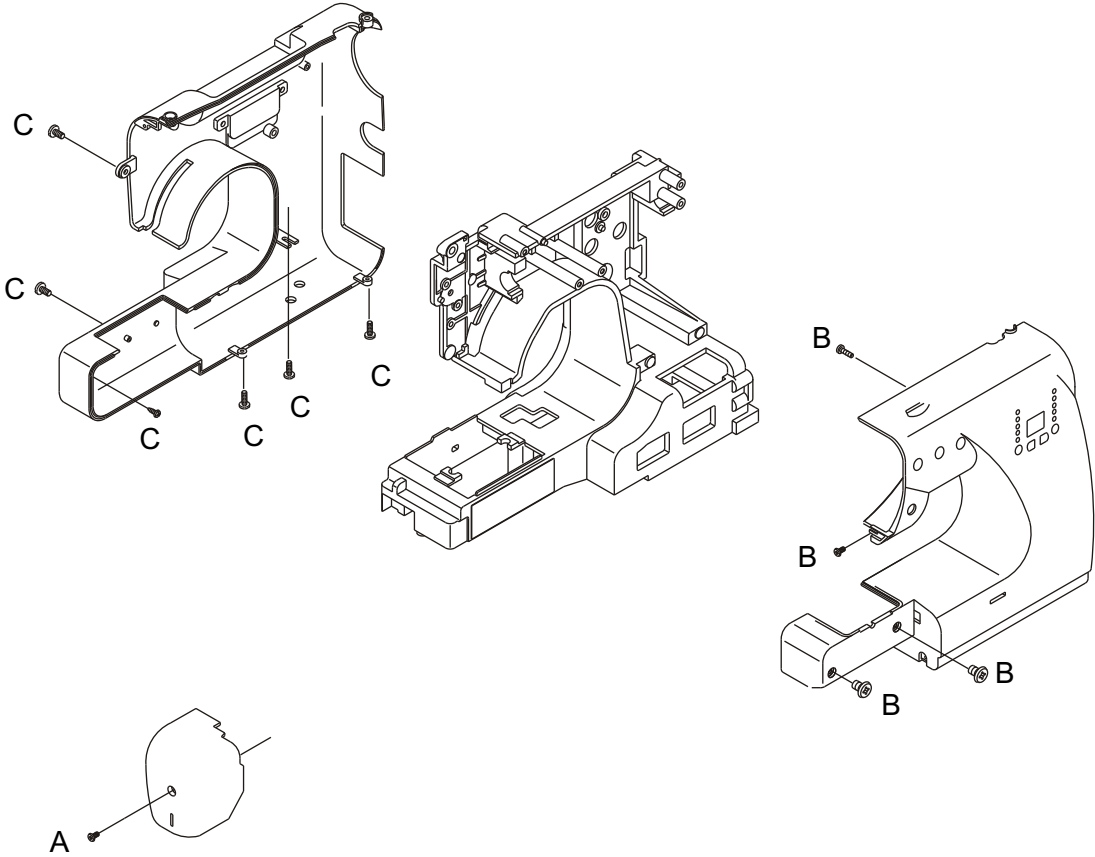

12. ADJUST THE STARTING POINT

1. Check: When turn on the machine, needle set at up or down position, UPC auto search the starting point.
Problem; UPC cannot auto search starting point when turn on the machine.
Solution: change Pc2 circuit board
Remark: When turn on the machine, needle set at between up or down position, UPC doesn't perform the motion for search the starting point.

2. Problem: the starting point different from standard
problem: When the starting point different with standard, sew the patterns unwell.
Check: try to sew the patterns:

Ex; When A ⇒  too large

- a. Use +screwdriver to loosen (A) screw
- b. Adjust (B) screw by anti-clockwise
- c. Fix (A) screw
- d. Sewing test
- e. Test OK, fix (A) screw

Ex: A ⇒  too small

- a. Use +screwdriver to loosen (A) screw
- b. Adjust (B) screw by clockwise
- c. Fix (A) screw
- d. Sewing test
- e. Test OK, fix (A) screw

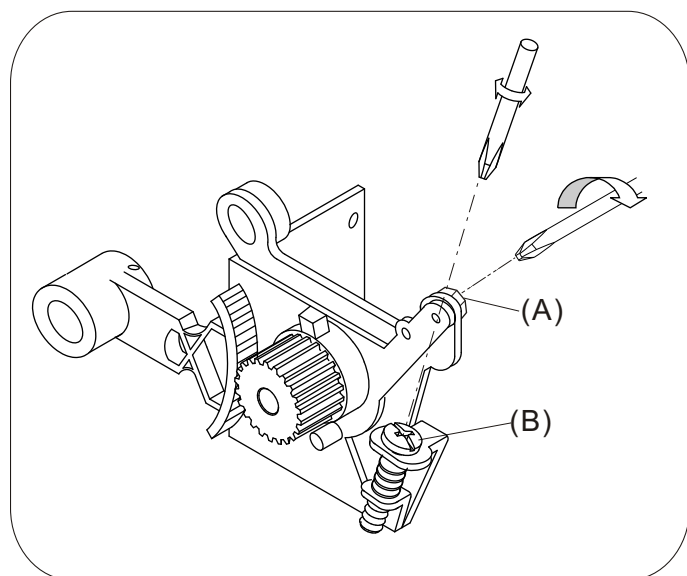

13. ELECTRONIC PARTS & CIRCUIT BOARD POSITION

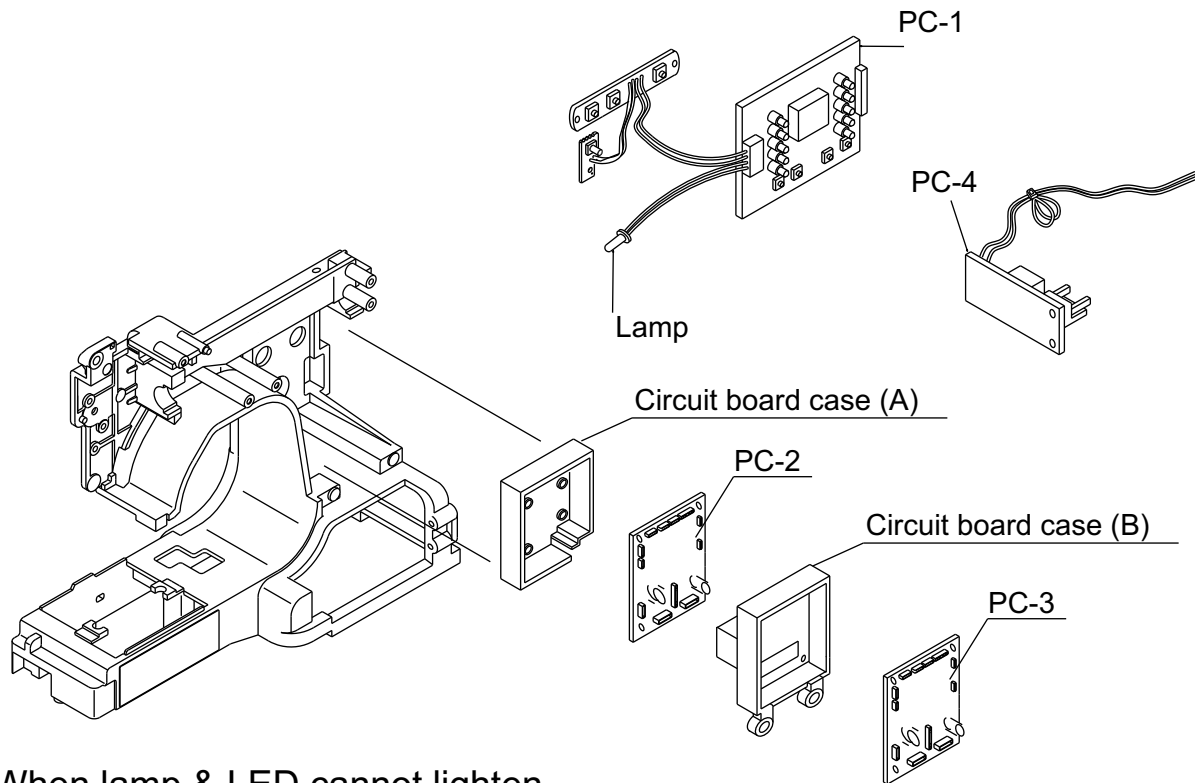

When lamp & LED cannot lighten

Problem: only lamp cannot lighten

Solution: change bulb

Problem : only LED cannot lighten

Solution: change
operate circuit board

Problem: Simultaneously cannot lighten

Check: the power plug whether plug in and
power switch whether

at "on", If all of these set up all right.

Solution: change the power support circuit
board.

When operate circuit board LED cannot lighten or all lighten

Problem: operate circuit board lighten two pieces or above simultaneously;

OR, cannot lighten when push

Solution: change operate circuit board LED

14. CIRCUIT CORD CONNECTION

YSD5K12S

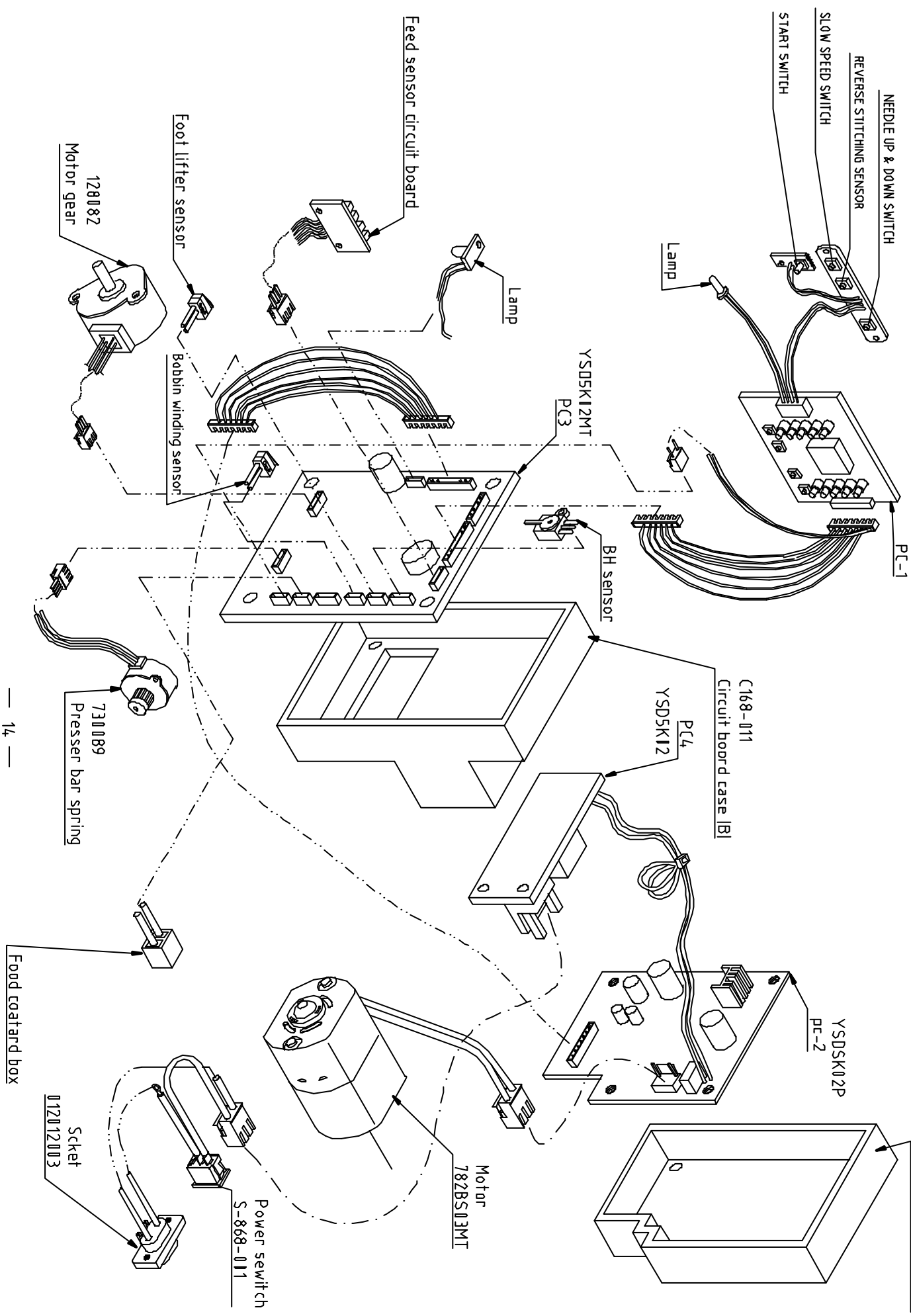

15.CHANGE Y SHAFT PUISE MOTOR (REGULATED MOTOR)

Construction ref. Part list drawing SCM168-10

Solution:

- 1.Loosen the hexagon screw of feed regulate crank, release feed regulated shaft, release 4 screws for release the complete set of feed regulate unit.
2. Loosen the hexagon screw of motor gear and loosen motor fixing screw,
Then release the motor of Y shaft for change new one.
3. Fixing the new motor at the feed motor plate, then return the motor gear.
4. Push the regulate plate of regulated motor gear (# 128082) for touch rule pole, tighten the hexagon screw for fix the regulated motor gear.
- 5.Tighten two screws at right & left sides for return the regulated unit at the arm then fix the feed regulate crank.
6. Push feed regulate gear & motor gear to grip, adjust to grip only 1 or 1.5 teeth.(note: motor gear plate must be keep touch the rule pole)
7. Fixing the two screws of feed motor plate return arm.

Ckeck:

- 1.switch turn on, try to sew



- 2.the starting point correct or error? If it is error, please reference point E to abjust.

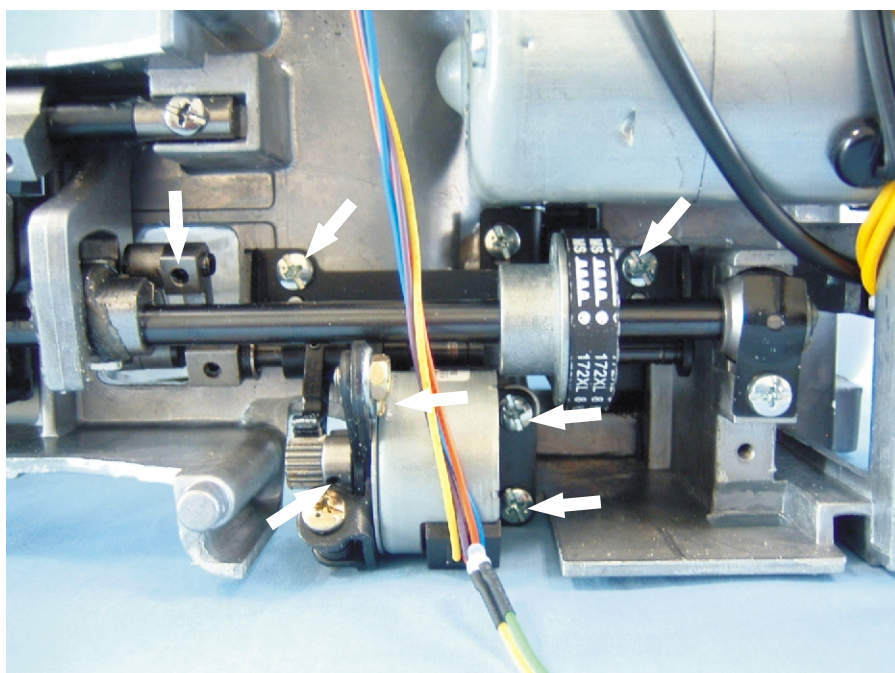

16. BH MOTION SWITCH ADJUST

Pattern select BH

Problem: BH presser foot up and down again, cannot normally touch BH connecting rod, so the start switch show red light.

Solution: Loosen the screw of BH switch case (#128024), then trimming backwards the switch case, return the screw and test again.

Check: 1. BH presser foot motions normally, start switch show green light, mean OK.

2. try to sew BH  , if sew normally mean OK.

Problem: If the user sew as  too much.

means BH switch box backwards

Solution: loosen the screw of switch case and trimming forwards then return the screw and test again.

Check: BH  sewing OK, confirm the BH motion normally and Start switch show green light.

