

# **MINI-STOP**

**QE3760**

**CE**

**Type**

# **DA40MS-II**

**Instruction Manual**

**Part 2**

QUICK-ROTAN Elektromotoren GmbH  
Königstraße 154  
67655 Kaiserslautern  
Tel: 0631 / 200 38 80  
Fax: 0631 / 200 38 62  
E-Mail: [tech.supp@quick-rotan.com](mailto:tech.supp@quick-rotan.com)  
[www.quick-rotan.com](http://www.quick-rotan.com)

**Englisch 2001-06-07**

# Contents

<b>Part 2</b>	<b>Page</b>
<b>7.</b> Description of the MINI-STOP drive system	7.1 - 7.5
7.1 Motor QE 3760	
7.2 Control system	
7.3 Speed control unit SWG2	
7.4 External operator panel OC-TOP	
<b>8.</b> Application	8.1 - 8.8
8.1 Sewing without an external operator's control panel	
8.2 Sewing with the external operator's control panel B2	
8.3 Sewing with external operator's control panel OC-TOP	
8.3.1 Sewing without sewing program (manual sewing)	
8.3.2 Sewing with sewing program (programmed sewing)	
8.3.3 Sewing programs	
8.3.4 Backtack / darning programs	
8.4 Error messages (malfunction diagnostics)	
<b>9.</b> Programming by the user	9.1 - 9.16
9.1 User programming with operator panel OC-TOP	
9.1.1 Direct programming	
9.1.2 Parameter programming	
9.1.2.1 Programming level A (operator level)	
9.1.2.2 Programming level B (technician level)	
9.1.2.3 Programming level C (special level)	
9.1.3 Reset	
9.2 User programming from the internal mini programming panel (MPP)	
9.2.1 Indication 1: backtack stitches	
9.2.2 Indication 2: speed	
9.2.3 Indication 3: sewing functions	
9.2.4 Indication 4: control parameters	
9.2.5 Reset	
<b>10.</b> Start of operation	10.1 - 10.5
10.1 Control of the direction of rotation and of the reference position from the needle bar (needle position NPO)	
10.2 Control of the needle positions NP1 / NP2 / NP3 / NP9	
10.3 Control of the needle positions NP5 for thread trimming	
10.4 Control of the maximum speed	
10.5 Hardware test	

**Technical updatings reserved!**

## 7. Description of the MINI-STOP Drive System

The MINI-STOP Drive System is an electronically commutated, brushless DC motor.

The system is composed of the following subassemblies

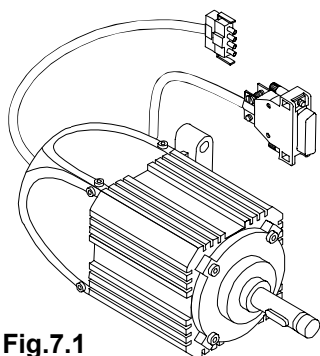

Fig.7.1

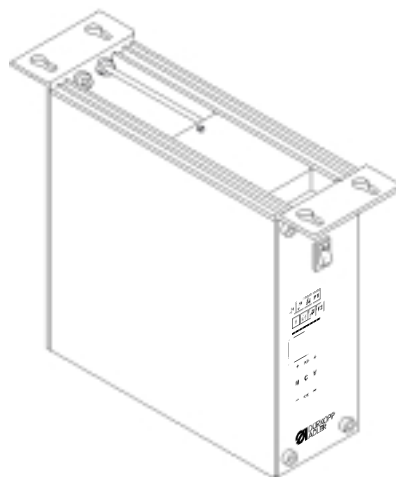

Fig.7.2

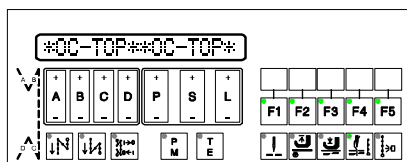
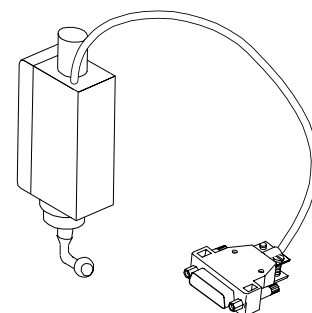

Fig.7.4



**Motor QE3760 (Fig.7.1)** with integrated optoelectronic incremental encoder for commutation and positioning.

**Control (Fig.7.2)** with

- integrated mains switch
- mains connection with interference rejection circuit
- electronically controlled combinational circuit
- intermediate DC circuit
- motor-driven current inverter
- electronic control for motor control and machine specific functions
- Mini programming panel
- connection for needle length

**Speed control unit SWG2 (Fig.7.3)**

**Control panel OC-TOP (Fig.7.4 - optional)**

### 7.1 Motor QE3760

The motor is a synchronous motor. It has a permanent-magnetic rotor, a stator with three-phase winding and an optoelectronic increment encoder for commutation and positioning.

The rated capacity of the motor (shaft capacity) is 370 W in S5 mode. The rated speed of the motor is 6000 rpm, the maximum speed is 9000 rpm.

The motor has two mains leads:

- four-wire with special quadripolar AMP plug (X1) for connecting the stator coil to the control system
- six-wire shielded with nine-pole D-sub plug (X2) for connecting the increment encoder to the control system.

## 7.2 Control system

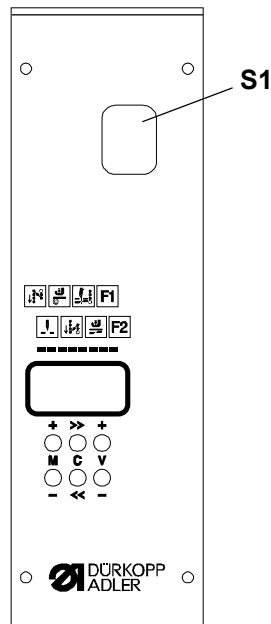

Fig. 7.5

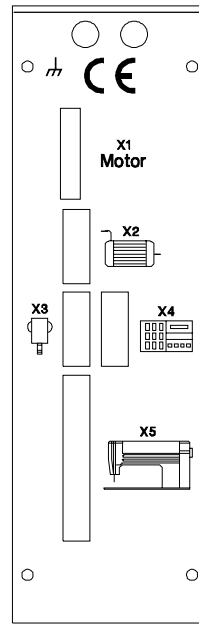

Fig 7.6

The control box is attached to the underside of the machine table by means of the four enclosed screws.

The mains connection is single-phase, using the three-wire cord protruding from the rear and a standard safety plug.

### The control system has peripheral functions

on the front panel (Fig. 7.5):

**1 mains switch**            **S1**

**the Mini control panel (MPF)**

contents:                    an LCD Display with 8 places

and 6 small keys:        **M+ / M-**  
                                   **C>> / C<<**  
                                   **V+ / V-**

on the rear panel (Fig. 7.6):

**sockets or connector plugs**

- X1** quadripole socket for connecting the motor's stator coil
- X2** nine-pole D-sub jack for connecting the motor's increment encoder
- X3** nine-pole D-sub plug for connecting set point adjuster SWG2 (Art. No. 63.012)
- X4** nine-pole D-sub plug for connecting the control panel OC-TOP/AP (Art. No. 64.175)
- X5** 37-pole D-sub jack for connecting the process control system (keys, switches, solenoids, solenoid valves) on the machine.

The control system is connected with the sewing machine/ sewing equipment via:

**inputs (Ex)**, such as for keys, switches, proximity switches, monitors, and  
**outputs (Ax)**, such as for solenoids, solenoid valves, signal indicators.

<b>Inputs (Ex)</b>	E1:	Feed reverse (manual backtack)	
	E2:	Needle position change-over	if <616> = I <sup>1)</sup>
		Needle up without trimming	if <616> = II
	E3:	speed limitation 2	
	E4:	speed limitation 3	
	E5:	backtack inversion	if <419> = I
		backtack suppression	if <419> = II
	E6:	Stop / starting block	
E7:	Flip-Flop 3		
E8:	Flip-Flop 2		

<sup>1)</sup> <616> = I means that parameter 616 (the parameter number 616) is set to „I“.  
 <616> = II means that parameter 616 (the parameter number 616) is set to „II“.

<b>Outputs (Ax)</b>	A1:	Thread trimmer forward	A20:	Flip-Flop 3 (Output "B")
	A2:	Presser foot lift	A21:	Flip-Flop 2 (Output "A")
	A3:	Feed reverse	A22:	Display S5
	A4:	Thread wiper	A23:	Display S8
	A6:	Thread tension release	A24:	Display S7

### 7.3 Speed control unit SWG2

The SWG2 is attached to the underside of the machine table with the enclosed brackets and connected mechanically to the machine's pedal by means of the enclosed rod assembly.

The mains connection of the SWG2 is by means of a nine-pole connector on plug X3 on the rear control panel.

The SWG2 is an analogous mechano-electronic converter, which converts the pedal path into analog voltage. This analog output voltage of the SWG2 is digitized in the control system so that the pedal path can be divided into 16 steps (positions).

Level	Position	Voltage [V]	Meaning
0	-2	0,00 - 0,50	Seam end, thread trimming
1	-1	0,50 - 0,94	Presserfoot up
2	0	0,94 - 1,76	Treadle position 0
3	+1	1,76 - 2,21	Presserfoot down
4	+1 D	2,21 - 2,43	Speed n1
5	+2 D	2,43 - 2,66	Speed n2
6	+3 D	2,66 - 2,90	Speed n3
7	+4 D	2,90 - 3,13	Speed n4
8	+5 D	3,13 - 3,37	Speed n5
9	+6 D	3,37 - 3,60	Speed n6
10	+7 D	3,60 - 3,84	Speed n7
11	+8 D	3,84 - 4,07	Speed n8
12	+9 D	4,07 - 4,31	Speed n9
13	+10 D	4,31 - 4,54	Speed n10
14	+11 D	4,54 - 4,78	Speed n11
15	+12 D	4,78 - 5,00	Speed n12

#### Pin connection of speed control plug (X3) of the SWG2

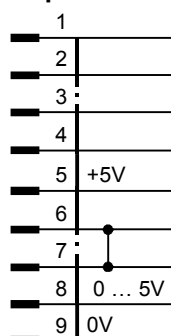

## 7.4 External operator panel OC-TOP

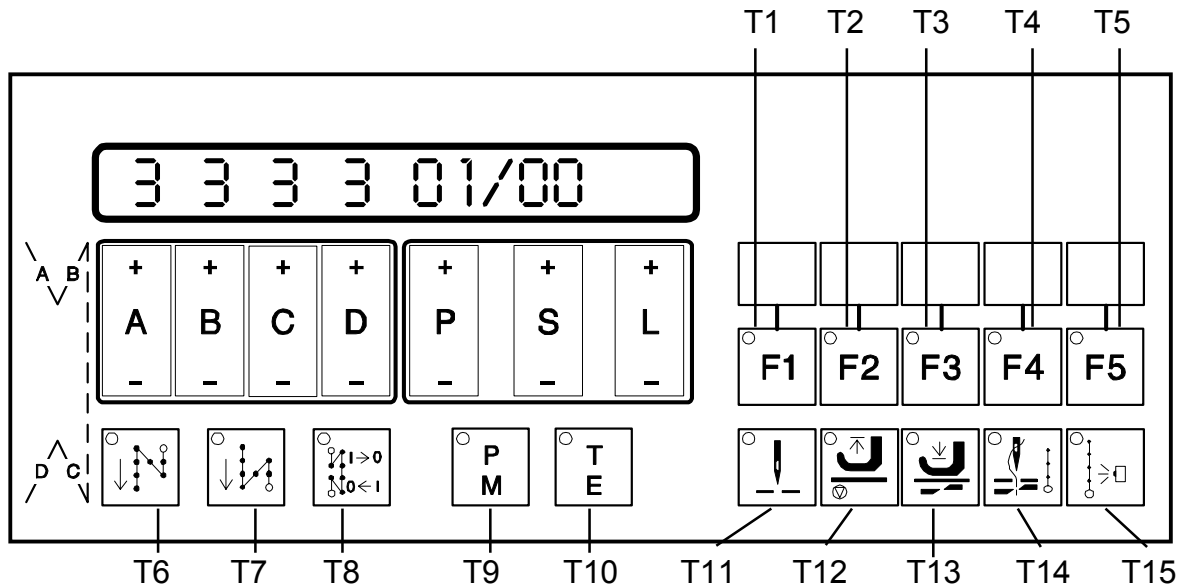

Fig. 7.7

The operator panel **OC-TOP** / DQ (Fig. 7.7) has the following components:

- **a display:** 16-digit LCD matrix
- **14 programming keys:**  
A+ / A-, B+ / B-, C+ / C-, D+ / D-, P+ / P-, S+ / S-, L+ / L-
- **two keys (T9, T10)** for selection of the operating mode
- **13 keys (T1...T8, T11...T15)** for machine functions
- **one connector for a light sensor** at rear for connection of one or two (with adapter) light sensors

### Function of the programming keys in operating mode "manual sewing" (key T9 is dark key T10 is dark)

- **A+/A-** adjustment of stitchcount A start backtrack
- **B+/B-** adjustment of stitchcount B start backtrack
- **C+/C-** adjustment of stitchcount C end backtrack
- **D+/D-** adjustment of stitchcount D end backtrack

### Function of the programming keys in operating mode "programmed sewing" (key T9 is bright, key T10 is dark)

- **A+/A-** adjustment of speed nx in program x
- **A+/A-** adjustment of stitchcount A start backtrack
- **B+/B-** adjustment of stitchcount B start backtrack
- **C+/C-** adjustment of stitchcount C end backtrack
- **D+/D-** adjustment of stitchcount D end backtrack
- **D+/D-** preselection of the program following program x
- **P+/P-** adjustment of program x (program number x)
- **S+/S-** adjustment of seam section (01...05) in program x
- **L+/L-** adjustment of the cycle counter for stacker activation
- **L+/L-** adjustment of stitchcount of a seam section

**Function of the programming keys in operating mode "parameter programming"**  
(key **T9** is dark, key **T10** is bright)

- **P+/P-** switch over of the hundreds of the parameter numbers
- **S+/S-** switch over of the parameter number in the switched on hundred section
- **L+/L-** programming of the parameter value of the switched on parameter number

**Function of the keys T9 and T10 for selection of the operating mode**

- **T9** dark, **T10** dark: manual sewing
- **T9** bright, **T10** dark: programmed sewing
- **T9** dark, **T10** bright: parameter programming
- **T9** bright, **T10** bright: teach in (s. chapter 9.1.1)

**Function of the programming keys for machine functions**

- **T5** function change-over for keys **T1** ... **T4** (shift key)
- **T1** linking for following seam sections (with / without)
- **T2** for speed control at programmed sewing:  
variable (treadle-controlled), if **T2** dark  
constant (automatic), if **T2** bright
- **T3** feed reverse for a seam section
- **T5+T3** single stitch
- **T4** seam section manual or stitchcounted
- **T5+T4** unit count in display
- **T6** start backtack (on / off)
- **T7** end backtack (on / off)
- **T8** backtack inversion
- **T11** needle position at sewing stop (up / down)
- **T12** presser foot position at sewing stop (up / down)
- **T13** presser foot position after seam end (up / down)
- **T14** thread trimming (on / off)
- **T15** sewing with light barrier (on / off)

**Caution:** After programming push key **T5** till LED goes out

The keys **T1...T15** are provided with one signal lamp each (LED). Each LED provides optical feedback on the control position of the function assigned to each key. If the function is ON, the LED is bright; if the function is OFF, the LED is dark.

## 8. Application

This **MINI-STOP** drive can be used **either with or without an external operator's control panel OCP**. Without the **operator's control panel OCP** is only manual sewing possible.

### Switching on

The on/off switch (mains switch) S1 is located at the front of the control unit. When activated and live, switch S1 is lit up.

### Maximum speed

The maximum speed can be adjusted with parameter <607> either with control panel **OC-TOP** or with the mini control panel at the front of the control unit.

## 8.1 Sewing without an external operator's control panel

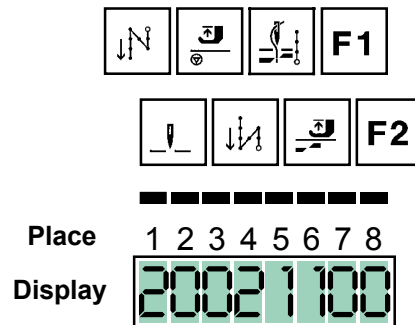

For sewing without external operator panel, programming on the mini programming panel located on the control housing front is function-relevant.

When Indication 3 „sewing functions“ is shown on the MPF display, the following functions can be selected:



Place	Symbol	Function	Display	Meaning
1		start backtick	0 1 2	without start backtick start backtick single start backtick double
2		needle position at seam stop	0 1	down up
3		presser foot at seam stop	0 1	down up
4		end backtick	0 1 2	without end backtick end backtick single end backtick double
5		thread trimming	0 1	without thread trimming with thread trimming



Place	Symbol	Function	Display	Meaning
6		presser foot after seam end	0 1	down up
7			0	without function
8			0	without function

## 8.2 Sewing with External Operator's Control Panel OC-TOP

### 8.2.1 Sewing without Sewing Program (manual Sewing)

Condition: key T9 (P/M) is dark  
key T10 (T/E) is dark

Display showing

- before start or after start, if <605> = II

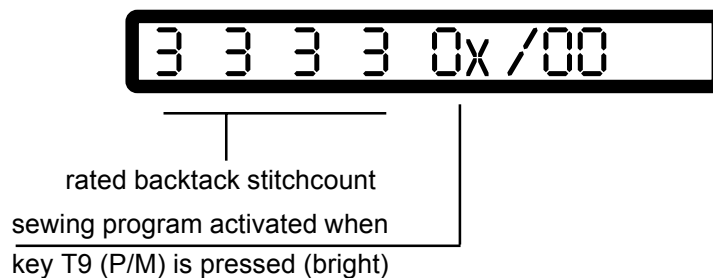

Setting of rated backtack stitchcount is possible only with the machine at standstill

for front backtack forward with key A+ or key A-

for front backtack backward with key B+ or key B-

for end backtack backward with key C+ or key C-

for end backtack forward with key D+ or key D-

Display showing

- before start, when <605> = I

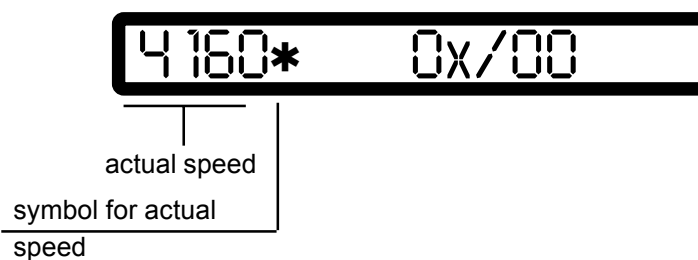

## 8.2.2 Sewing with Sewing Program

Condition: key T9 (P/M) is bright  
key T10 (T/E) is dark

Display showing before start

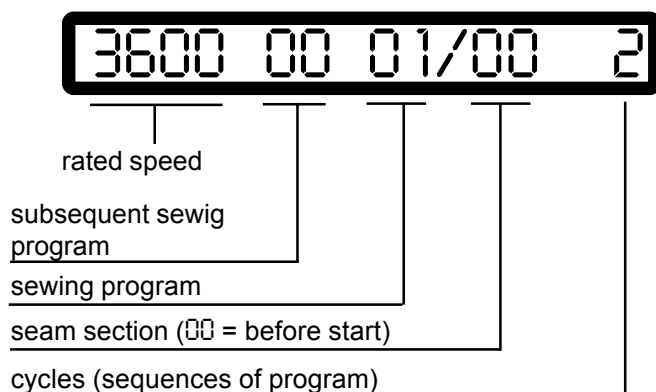

When this is displayed, the following can be modified:

- program: by actuating keys P+ or P-
- seam section: by actuating keys S+ or S-
- cycles: by actuating keys L+ or L-
- the subsequent sewing program via keys D+ or D-
- rated speed for the program: by actuating keys A+ or A-  
This speed is limited by parameter <221>

Display before start, if a seam section has been activated

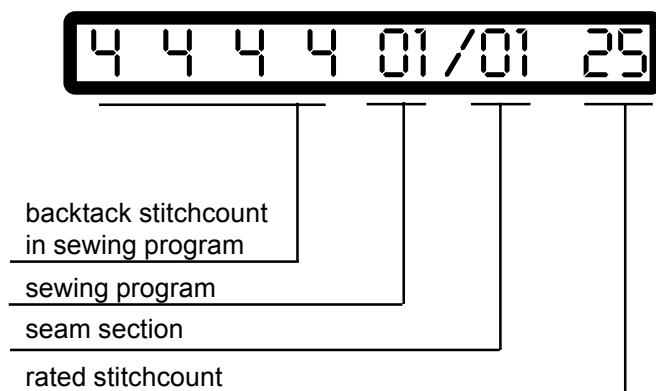

When this is displayed, the following can be modified:

- the preset backtack stitchcount for the program by actuating the keys located below the respective digits
- rated stitchcount of a seam section: by actuating keys L+ or L-
- seam section: by actuating keys S+ or S-
- program: by actuating keys P+ or P-

Display showing after start, when <605> = II

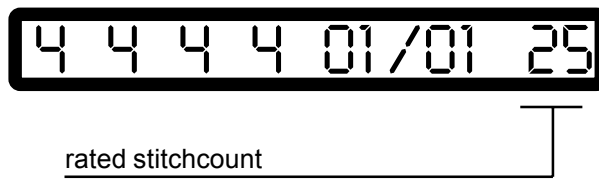

Display showing after start, when <605> = I

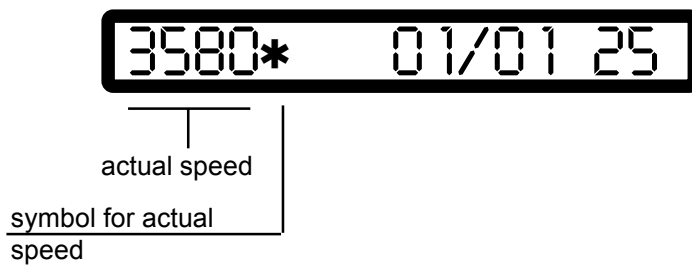

## 8.2.3 Sewing programs

a ) Number of sewing programs: 5

b ) Number of seam sections per sewing program: 5

c ) Number of stitches per seam section: max.99

**d ) Adjustment of seam functions at the seam section:**

front backtack	via key T6
end backtack	via key T7
needle position at sewing stop	via key T11
presser foot position at sewing stop	via key T12
presser foot position after seam end	via key T13
thread trimming	via key T14
feed reverse	via key T3 if T5 is off
Linking with the next seam section	via key T1 if T5 is off
Sewing speed constant(automatic) or variable (treadle controlled)	via key T2 if T5 is off
Seam section without stitchcount	via key T4 if T5 is off
Light barrier control	via key T15

**e ) Breaking of stitchcount**

Stitchcount of a seam section can be broken via treadle position "-2."-letter "ñ" appears on the display. Manual sewing (without stitchcount) is now possible. Set treadle again at "-2" to complete seam section and advance the next one.

**f ) Seam section without stitchcount**

Seam sections can be also be sewn without stitchcount (manual):  
switch on T4 when T5 is off (LED dark). "m" on display signals manual seam section. For seam sections without stitchcount, display must show stitchcount  $\geq 1$ .  
Set treadle at "-2" to complete seam section and advance the next one.

**g ) Seam section with light barrier control**

The rated stitchcounts stored for this seam section are light barrier compensation stitches.

**h ) Sewing speed**

The sewing speed can be individually set for each program via display before starting the sewing operation. The maximum sewing speed to be programmed is defined by parameter <221>.

**i ) Interlinking of sewing programs**

It is possible to run several consecutive sewing programs. When programming, the subsequent program is displayed by digits 6 and 7 and can be entered via key D+ and D-.  
□□ means that the current program will be performed exclusively; at its end return is made to its start.

**j) The programs can be used as **backtack or darning programs****

Change-over is made via parameter <313>

## 8.2.4 Backtack/Darning Programs

- The sewing programs are turned into backtack/darning programs when parameter <313> = I.
- In each program, only seam sections 1 and 2 become active, section 1 being sewn forward and section 2 backward.
- The cycle counter (shown on the righthand side of the display above keys L+/L- before sewing start) determines the number of backtacks (single, double, 3 times, 4 times).
- The **darning program** is a special backtack program. In this case, reset the cycle counter to "0".
- Seam end is initiated in the darning program by treadle position "-2".
- Five backtack/darning programs are available.
- Each program has one of the five function keys T1 ... T5 assigned to it.
- The activated program is indicated on the display above keys P+/P- and/or by the assigned key T1 ... T5 being luminous.
- On the lefthand side of the display, the preset maximum speed possible in the program is shown before sewing start. This speed can be varied via the keys A+/A- and can be limited via parameter <221>.
- The backtack/darning programs can be operated either at variable (treadle-controlled) or constant speed (not controlled by the treadle).
- Sewing at constant speed:  
With <313> = II, switch on key T2 (luminous) during the seam sections, subsequently set <313> = I; this means backtack/darning program activated.
- Stitch compensation is activated via parameter 304. Its value (<304>) determines delayed deactivation (ms) of the feed reverse after seam section 2.

## 8.3 Error Messages (Malfunction Diagnostics)

The control system of the drive cyclically tests its own functional condition and the functional condition of the complete drive system.

Malfunctions are signalled via the display of the external operator panel, for instance:



### List of possible error codes:

1	Treadle not in zero position when mains power is turned ON
9	Start lock
10	Machine class, <799> was changed; remedy: turn mains power switch OFF and ON again
62	Short circuit on 24 V (32 V) DC
63	Overload on 24 V (32 V) DC, load current > 4 amps
64	Power supply monitor: voltage too low (90 V - 150 V)
65	Power electronics not operational after mains power ON, mains power < 130 V
66	Earth short (motor or motor supply line has earth short in one or more phases)
67	Internal malfunction
68	Power electronics shut-off
	a) Overcurrent, short circuit in motor or supply line
	b) Overvoltage, mains voltage too high (>300 V), motor overloaded while decelerating
	c) Undervoltage
70	Machine blocked, no increment from synchronizer at max. motor torque
71	Commutation transmitter plug not inserted
73	Motor overloaded
75	Internal malfunction
90	EEPROM does not exist
91	EEPROM not programmable
92	Start lock while motor running
93	Wrong EEPROM
100-117	} Internal malfunction
117	

**In case of error messages  $\geq 62$ , the motor will stop in undefined positions.**

Control system reset possible only by mains power OFF/ON.

## 9. Programming by the user

Programming by the user is specific switching-on or adjustment of machine-functions and parameters.

User programming of the **MINI-STOP** is possible either via the integrated miniature control panel (**MPF**) or via the external operators panel (**OC-TOP**)

User programming of the **MINI-STOP** is possible via:

- **direct programming** and/or
- **programming parameters.**

The programming of parameters is possible via three levels of program:

- **Programming on level A** (operator level)
- **Programming on level B** (technician's level)
- **Programming on level C** (special level)

### 9.1 User programming with operator panel OC-TOP

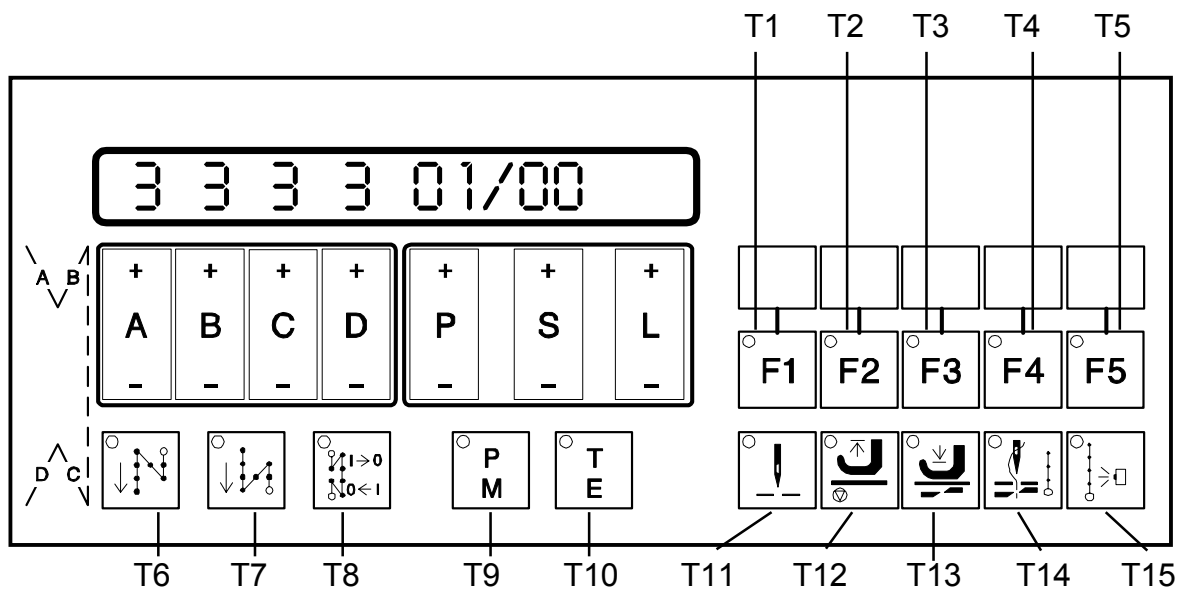

Fig. 9.1

## 9.1.1 Direct programming

Attention! All values modified within direct programming are stored only when  
a) the drive system is started or  
b) key T9 (P/M) are pressed.  
If the drive system is switched off via the mains power switch immediately after any values were modified, the values set before modification will be retained!

Regardless of the programming levels, certain values can be programmed without calling up parameter numbers - i.e. directly.

The following values can be modified by direct programming:

Front backtack stitchcount forward  
Front backtack stitchcount backward  
End backtack stitchcount backward  
End backtack stitchcount forward  
Stitchcounts for seam sections  
Speeds for seam sections  
Functions for seam sections

### a) Modification of backtack stitchcounts

Display shown when "manual sewing" is ON (T9 (P/M) and T10 (T/E) not luminous)



A digital display with a black border showing the number '3' four times, followed by '0x/00'.

Display shown when "programmed sewing" is ON (T9 (P/M) luminous, T10 (T/E) not luminous)



A digital display with a black border showing the number '4' twice, '3' twice, '0x/01', and '25'.

The symbolic seam pictogram on the lefthand side of the operator panel shows the backtack sections

A: Front backtack forward  
B: Front backtack backward  
C: End backtack backward  
D: End backtack forward

Immediately below the display, there are keys

A+/A- for backtack section A,  
B+/B- for backtack section B,  
C+/C- for backtack section C,  
D+/D- for backtack section D

These keys permit to increase or decrease the backtack stitchcounts.



## b) Programming of the stitchcount for a seam section

Condition: Operation mode „programmed sewing“ is on, i.e. key T9 (P/M) is bright and key T10 (T/E) is dark, machine not sewing

Display showing

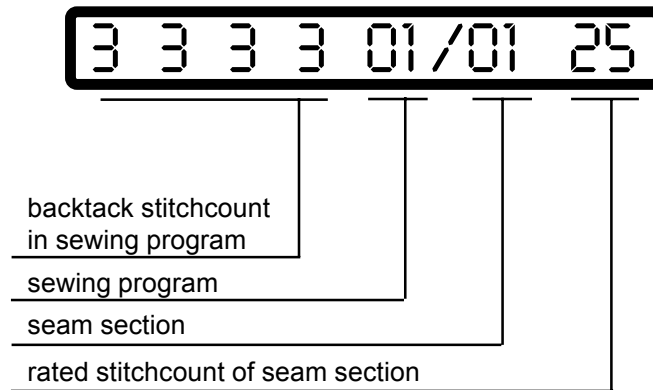

Activation of a **sewing program** is made via keys P+ or P-

Activation of a **seam section** is made via keys S+ or S-

Programming of the **stitchcount** for the seam section is made via key L+ (value increased) or L- (value decreased)

## c) Programming of seam sections by „Teach-in“ (performing work)

Condition: Key T9 (P/M) is bright  
Key T10 (T/E) is bright

The machine must have performed at least one stitch before.

Activate the desired program in the display via keys P+ or P- and the seam section to be programmed via keys S+ or S-.

Cycle:

- Treadle forward  
Reaction: the stitchcount which has been registered up to now will be eliminated
- Treadle returns to zero position
- Treadle forward  
Reaction: machine sews, the sewed stitches will be added in, shown in the display and registered

Correction of the value shown in the display is possible via key L+ or L-.

## b) Programming of the stitchcount for a seam section

Condition: Operation mode „programmed sewing“ is on, i.e. key T9 (P/M) is bright and key T10 (T/E) is dark, machine not sewing

Display showing

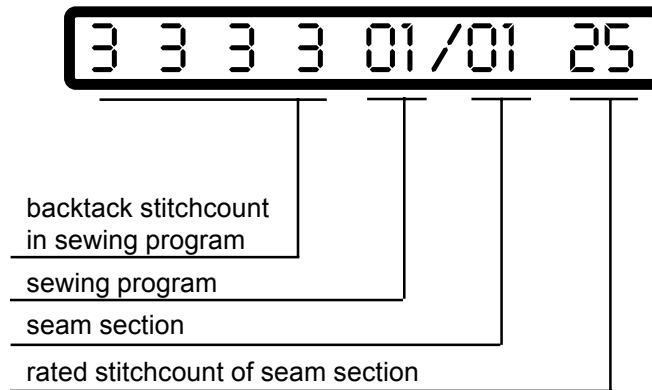

Activation of a **sewing program** is made via keys P+ or P-

Activation of a **seam section** is made via keys S+ or S-

Programming of the **stitchcount** for the seam section is made via key L+ (value increased) or L- (value decreased)

## c) Programming of seam sections by „Teach-in“ (performing work)

Condition: Key T9 (P/M) is bright  
Key T10 (T/E) is bright

The machine must have performed at least one stitch before.

Activate the desired program in the display via keys P+ or P- and the seam section to be programmed via keys S+ or S-.

Cycle:

- Treadle forward  
Reaction: the stitchcount which has been registered up to now will be eliminated
- Treadle returns to zero position
- Treadle forward  
Reaction: machine sews, the sewed stitches will be added in, shown in the display and registered

Correction of the value shown in the display is possible via key L+ or L-.

## d) Programming of cycles (number of sequences of program), of program speed and of the subsequent program

Condition: Operation mode „programmed sewing“ is on, i.e. key T9 (P/M) is bright and key T10 (T/E) is dark, machine not sewing

Display showing

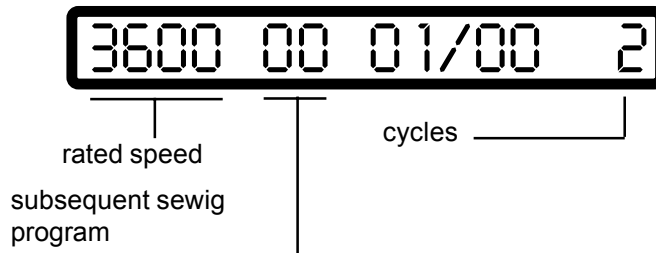

Cycle programming is made via the keys L+ (number increased) or L- (number decreased)

Programming of the **speed** for the program is made via key A+ (value increased) or A- (value decreased)  
This speed is limited by parameter <221>

Programming of the **subsequent sewing program** is made via keys D+ or D-.

## e) Programming of functions

Functions for the seam sections are controlled via the functional keys

T6	Front backtack or start stitch condensation (with/without)
T7	End backtack or end stitch condensation (with/without)
T11	Needle position at sewing stop and at the end of a seam section (up/down)
T12	Presser foot position at sewing stop (up/down)
T13	Presser foot position at the end of a seam section (up/down)
T14	Thread trimming at the end of a seam section (with/without)
T15	Sewing with light barrier (with/without)
T1	Linking of seam section (with/without), if T5 is dark
T2	Speed control, if T5 is dark variable (treadle-controlled, T2 is dark) or constant (automatic, T2 is bright)
T3	Transport reverse or stitch condensation of a seam section, if T5 is dark
T4	Seam section manual or stitchcounted, if T5 is dark

### 9.1.2 Parameter programming

#### 9.1.2.1 Programming level A (operator level)

This level is used for programming control parameters which immediately affect the operation sequence.  
These are the parameters for the following functions:

- Front backtack (double or single)	<148>
- End backtack (double or single)	<149>
- Backtack (standard backtack or decorative backtack)	<523>
- Light barrier compensation stitches	<111>
- Light barrier fade-out	<112>
- Softstart	<116>

## a) Activation of programming level A

Conditions

Mains power switch ON

Drive system not running

Operating mode: manual sewing must be ON (key T9 (P/M) dark)



The LCD display shows four '3's followed by '0x/00'.

Press key T10 (T/E)

Response:

Key T10 (T/E) becomes bright, the display shows in its righthand half the first parameter (parameter no. and parameter value) associated with programming level A.

Sewing is not possible



The LCD display shows four '3's followed by '111' and '6'.

- Programming

The parameter number is set by using keys P+ or P- (hundreds of parameter no.) and keys S+ or S- (tens and units of parameter no.). The parameter value is programmed by using key L+ or L-

## b) Deactivation of the programming level A

Press key T10 (T/E)

Response:

Key T10 (T/E) goes dark, the display returns to initial condition.

Sewing is possible.



The LCD display shows four '3's followed by '0x/00'.

### 9.1.2.2 Programming level B (technician level)

This level is used for programming the control parameters which have to be modified or adapted very rarely or only for starting operation of the system.

#### a) Preparation for activation of the programming level B

Turn mains power switch OFF

Press and hold keys T9 (P/M) and T10 (T/E) simultaneously

Turn mains power switch ON

Release keys

Response:

The display shows a „\*“ between program and seam section.

Sewing is possible.



The LCD display shows four '3's followed by '0x\*00'.

## b) Activation of programming level B

Press key T9 (P/M) (not becoming bright) and press key T10 (T/E) (becoming bright)

Response:

In the righthand half of the display are shown: a parameter number (at first 104, then the number selected last) and the associated value.

Sewing is not possible.



The image shows a digital display with a black border. On the left side, there are four '3' characters. On the right side, the number '104' is displayed, followed by a space and the number '8'.

Modification of parameter number:

for hundreds of parameter numbers use key P+ or P-

for tens and units of parameter numbers use key S+ or S-

Modification of parameter value: via key L+ or L-

## c) Deactivation of programming level B

Press key T10 (T/E) (not becoming bright)

Response:

Parameters shown disappear from the display, the display returns to initial condition

Sewing is possible.



The image shows a digital display with a black border. On the left side, there are four '3' characters. On the right side, the text '0x\*00' is displayed.

### 9.1.2.3 Programming level C (special level)

**Attention!**

**At this level, control parameters are stored the values of which have to be modified in exceptional cases only. Correction of these parameters should therefore be made only after consultation of the manufacturer.**

Activation of programming level C

- a) Activate programming level B (see 9.1.2.2)
- b) Call up parameter 798
- c) Set parameter value <798> to I
- d) Deactivate programming level B
- e) Turn mains power switch OFF, wait for >2 secs. to elapse
- f) Turn mains power switch back ON
- g) Press key T10 (T/E) (becoming bright)

Response:

In the righthand half of the display appears the first parameter of programming level C.

Calling up further parameter numbers and correcting the parameter values can be made in the same way as described for programming levels A and B.

Deactivation of programming level C:

- Press key T10 (T/E) (not becoming bright)
- Turn mains power switch OFF

### 9.1.3 Reset

#### a) Reset of parameter values

All parameter values having been modified from the ex-factory condition (standard value) are reset to their standard values by this procedure.

**Exceptions:** parameters 700, 799 and 800 and further parameters signed with „\*“  
For these parameters, the values programmed by the user are retained even after -Reset- has been performed.

-Reset- procedure:

- turn mains power switch OFF
- press treadle fully forward and hold in that position
- press and hold keys P- or P+, S- or S+ and L- or L+ simultaneously
- turn mains power switch ON
- release the three keys and the treadle

Response: Display showing



RESET Y -- N

Now -Reset- can be performed.

Located below the display Y (yes) there is key P+. Press this key P+ to start the reset. The display briefly shows:



MASTER-RESET

After that the display shows the power-on display for approx. 2 secs.



X40mS 7Z-040-H

and then shows the display corresponding to the operating mode selected



3 3 3 3 0x/00

If it is not desired to start the -Reset-, press key L+ located below the display saying N (no).

## b) Reset of parameter values and sewing programs

The reset procedure including the data of the sewing programs is analog to that described under a), until the following appears in the display:



In order to reset the data of the sewing programs to their original values, it is now required before pressing key P+ to press at first key T8 and hold until activation is acknowledged in the display.

## 9.2 User programming from the internal mini programming panel (MPP)



Abb. 9.2

The MPP has the following functional elements:

- the six programming keys: **M+** / **M-** / **C>>** / **C<<** / **V+** / **V-**
- the display: eight-digit LCD matrix

To each digit in the display, a symbol for a sewing function is assigned.

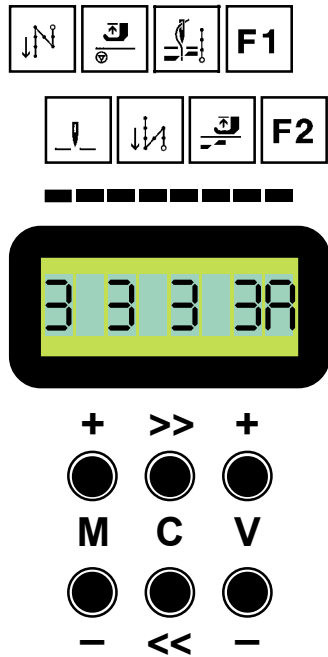
The MPP is only activated if no external OC-TOP operator panel is connected to the control unit.

When the drive is turned on, the display shows the Indication 01 for approx. 1 sec.: control unit type (e.g. DA40MS02).

Indication 01: 

The display will then show the Indication 02: software version (e.g. 7Z\_101\_2).

Indication 02: 

After expiry of approx. 1 sec., Indication 1 (Backtack stitches) is activated.

The following different Indications can be set on the display:

- Indication 1:** backtack stitches
- Indication 3:** speed
- Indication 3:** sewing function
- Indication 4:** control parameter
- Indication 5:** hardware test (<797> = I, see chap. 10.5)
- Indication 6:** reset



Pressing the M+ or M- keys switches between indication 1 to indication 4; this is only possible while the drive is stopped.

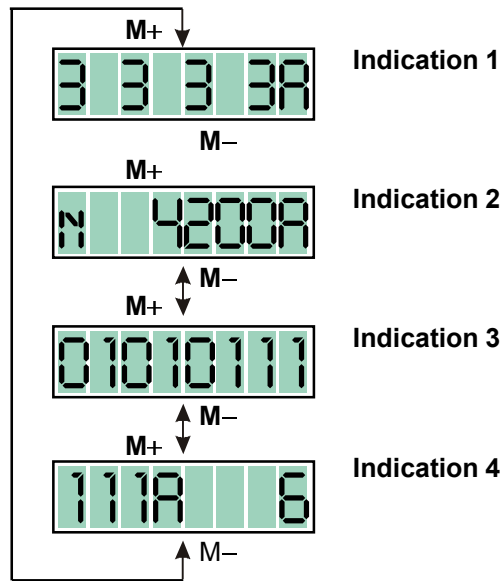

### Sewing:

Sewing is possible with any of the Indications 1, 2, 3 and 4, unless one of the display digits is flashing.

### Programming:

Programming is possible as soon as a display digit is flashing.

Release for programming and switching from one display digit to the next is effected by pressing the **C<< / C>>** keys; this is only possible while the drive is stopped.



### 9.2.3 Indication 3: sewing functions

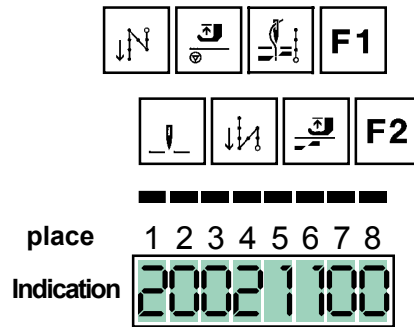

place	symbol	function	Indication	meaning
1		front backtack	0 1 2	none front backtack single front backtack double front backtack
2		needle position at sewing stop	0 1	down up
3		presser foot at sewing stop	0 1	down up
4		End backtack	0 1 2	none end backtack single end backtack double end backtack
5		thread trimmer	0 1	without thread trimmer with thread trimmer
6		presser foot after seam end	0 1	down up
7			0	no function
8			0	no function

## Programming of the sewing functions

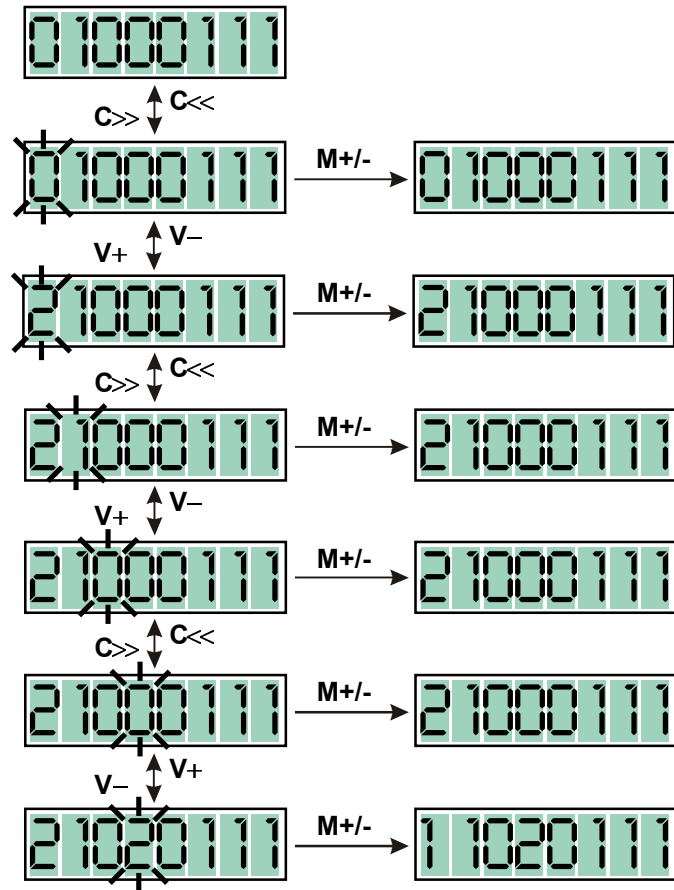

### Programming sequence

- Pressing the **C<<** or **C>>** key makes the display digits flash, sewing is not possible.
- Pressing the **V+** or **V-** key allows you to increment or decrement the number displayed at the flashing display position.
- Pressing the **M+** or **M-** key deactivates flashing, sewing is possible again.

### 9.2.4 Indication 4: control parameters

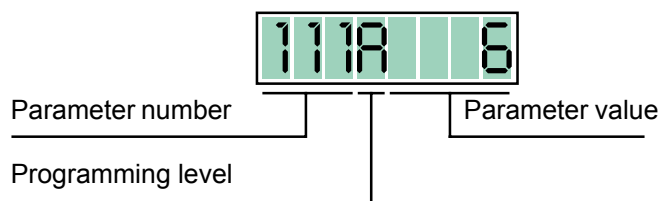

For the meaning of the control parameters, refer to chapter 11.3, Parameter overview, and chapter 11.4, Parameter list.

The control parameters are arranged on three different programming levels (A, B, C).

#### Programming level A

Parameters of programming level A can be retrieved upon normal drive activation.

## Programming level B

In order to retrieve parameters of programming level B, proceed as follows when activating the machine:

- turn off mains switch **S1**,
  - press the **M+** and **V+** keys at the same time and keep pressed,
  - turn on mains switch **S1**.
- In the Indication 1 „B” is shown in the right-hand (8th) display digit.

Pressing the **M+** or **M-** key allows you to switch to Indication 4.

### Control parameter programming

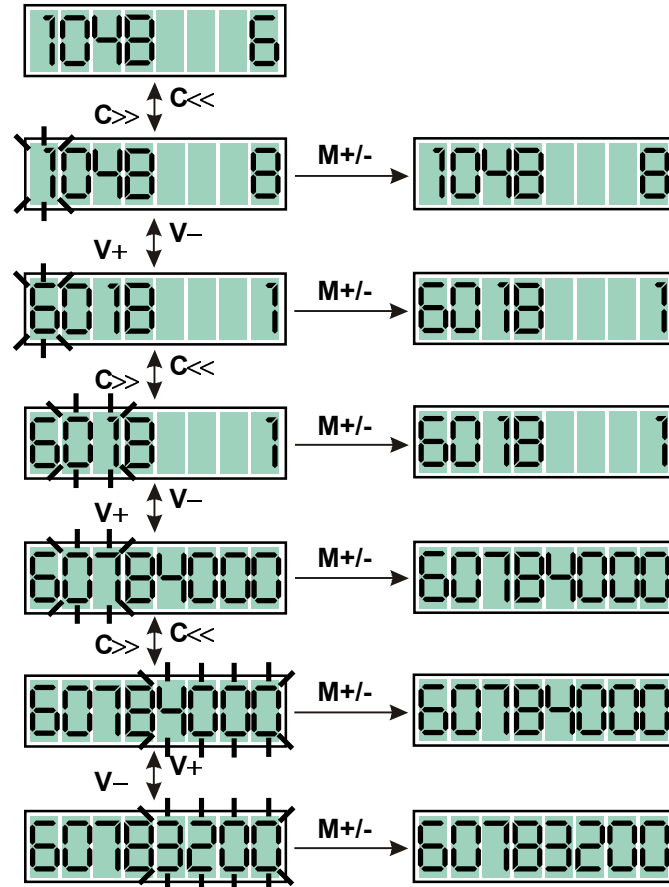

### Programming sequence

- Pressing the **C<<** or **C>>** key makes the display digits flash, sewing is not possible.
- Pressing the **V+** or **V-** key allows you to increment or decrement the number displayed at the flashing display position.
- Pressing the **M+** or **M-** key deactivates flashing, sewing is possible again.

## Programming level C

In order to retrieve parameters of programming level C, you first need to change parameter 798 (software switch) to I (<798>=I) on programming level B as a preparatory measure.

Then either change the Indication by pressing the **M+** or **M-** key, or retrieve another parameter by pressing the **C<<** or **C>>** and **V+** or **V-** key.

Now turn off the mains switch, then turn it on again.

→ In the Indication 1 „C” is shown in the right-hand (8th) display digit.

Pressing the **M+** or **M-** key allows you to switch to Indication 4.

Programming level C is now active.

Programming level C includes all parameters (including those of levels A and B).

## 9.2.5 Reset

All parameter values having been modified from the ex-factory condition (standard value) are reset to their standard values by this procedure.

Exceptions:

parameters 700, 799 and 800, and some other parameters marked by a „\*“ in the parameter list. For these parameters, the values programmed by the user are retained even after **-Reset-** has been performed.

### „Reset“ procedure:

- turn off mains switch **S1**,
- Push the pedal forward to end position and hold in that position
- press the **M-** and **V-** keys at the same time and keep pressed,
- turn on mains switch **S1**.
- release the two keys and the pedal

Reaktion: Indication 6



Press the **M+** key if a reset is to be performed, press the **M-** key if a reset is not to be performed.

Indication 1 is then shown on the display.



## 10. Start of operation

If the MINI-STOP has been stored at a temperature of  $<+5^{\circ}\text{C}>$ , then a working temperature of between  $+5^{\circ}\text{C}$  and  $+40^{\circ}\text{C}$  must first be obtained.

The equipment must be dry.

Before work with the machine can be started, make sure to perform the following:

- a) Control the direction of rotation and the reference position of the needle bar
- b) Control the needle positions
- c) Control the maximum speed

### 10.1 Control of the direction of rotation and of the reference position from the needle bar (needle position NPO)

- a) Activate programming level B (technician level) (see section 9.1.2.2 „programming level B“)
- b) Set parameter 700
- c) Actuate treadle briefly forward:  
Reaction: The machine performs a full revolution and then positions in a random position.
- d) Is the direction of rotation correct?  
When yes, then proceed to adjust the reference position, proceed with e) below  
If no, then activate parameter 800 and change the value  $<800>$  ( $\text{I} \rightarrow \text{II}$  or  $\text{II} \rightarrow \text{I}$ ) than proceed as b)
- e) Turn the handwheel of the machine in the direction of rotation until the point of the needle coming from up to down touches the level of the throat plate (= reference position).  
When doing this it is important that parameter  $<701> = \text{I}$ .
- f) Actuate the treadle briefly forward:  
Reaction: The machine performs one revolution and positions in the same position that had been previously obtained by hand.
- g) As soon as new parameter numbers are activated, or the programming level B is negated, then the parameter value  $<700>$  is memorized and the reference position adjustment is completed.

### 10.2 Control of the needle positions NP1/NP2/NP3/NP9

NP1 - needle down position ( $<702>$ )

NP2 - thread take up lever in the up position ( $<703>$ )

NP3 - needle up ( $<710>$ )

NP9 - thread tension release / thread catcher start ( $<707>$ )

- a) Activate programming level B (technician level) (see section 9.1.2.2 „programming level B“)
- b) Activate parameter 702
- c) Actuate the treadle briefly forward  
Reaction: The machine performs a revolution and then positions at the programmed  $<702>$ .
- d) Is the needle position correct?  
When yes, then proceed as with g) below.  
When no, then the position must be changed by turning the hand wheel (when  $<701> = \text{I}$ ) or via key L+ or L- (when  $<701> = \text{II}$ )
- e) Actuate the treadle briefly forward  
Reaction: The machine performs a revolution and positions in the same position.
- f) The position can again be corrected.  
When no further correction is needed, then proceed as with g) below.
- g) As soon as another parameter number is called up, e.g. example 703, the previously programmed value of  $<702>$  is memorized.
- h) With parameter 703 and 710 correction is obtained as described above for parameter 702.
- i) Deactivate programming level B (see section 9.1.2.2 „programming level B“).

### 10.3 Control of the needle position NP5 for thread trimming

NP5 - End cutting signal 1 (<705>)

- a) Activate programming level B (technician level) (see section 9.1.2.2 „programming level B“)
- b) Set parameter 705
- c) Actuate the treadle briefly forward  
Reaction: The machine performs a revolution and positions at the Indicationd <705>.
- d) Is the position correct?  
When yes, then proceed as g) below.  
When no, then the position must be corrected by turning the hand wheel (when <701> = I) or via keys L+ or L- (when <701> = II).
- e) Activate the treadle forward.  
Reaction: The machine performs a revolution and positions at the corrected program value <705>.
- f) The position can again be corrected.  
If no further correction is needed, then proceed as g) below.
- g) Back heel the treadle.  
Reaction: The machine rotates to NP2, <705> is memorized, programming (correction of position) is no longer possible.
- h) If the treadle is back heeled then the thread trim procedure will be activated and the machine performs one revolution.
- i) Should parameter <705> be changed again, then the sequence from c) above must be repeated.
- j) Deactivate program level B (see section 9.1.2.2 „programming level B“).

### 10.4 Control of the maximum speed

- a) Activate programming level B (see section 9.1.2.2 "programming level B")
- b) Set to parameter 607
- c) Check the parameter value <607> and make correction if necessary via keys L+ or L-
- d) Deactivate programming level B (see section 9.1.2.2 "programming level B")



## 10.5 Hardware Test

Hardware Test is a check routine permitting to use the operator panel **OC-TOP** or the mini programming panel **MPF** for testing various components of the drive system (control system) and of the machine installation.

Activation of the „hardware test“ = „HW-Test“ routine

- a) Activate programming level „B“ and call up parameter 797
- b) Set <797> to 1
- c) Deactivate programming level „B“
- d) Turn off mains switch **S1**
- e) Wait for approx. 2 secs. to elapse, and turn on main switch S1 again.

Response: The display shows „HARDWARE TEST“ for approx. 2 secs.

Indication **OC-TOP**:

A 16-character LCD display showing the text "HARDWARE TEST" in a green, segmented font. The text is centered and occupies most of the display width.

Indication **MPF**:

A 10-character LCD display showing the text "HW-TEST" in a green, segmented font. The text is centered and occupies most of the display width.

After that, the display shows the first test block: Inputs.  
All OC-TOP keys equipped with LEDs become bright

Survey of test blocks:

Test-Block	Check	Indication OC-TOP	Indication MPF
1	Inputs		
2	Outputs		
3	Speed control-unit		
4	Synchronizer		

To call up the test blocks (advancing from test block to test block), use keys **A+** and **A-** on the **OC-TOP** or with the keys **M+** / **M-** on the **MPF**.

To call up various functional elements within a test block such as advancing from an Input to the next, use keys B+ and B- on the control panel **OC-TOP** or with the keys C>> / C<< on the **MPF**.

To activate functional elements selected, use key **D+** on the **OC-TOP** or the key **V+** on the **MPF**.

### Test block 1: Inputs

Display:

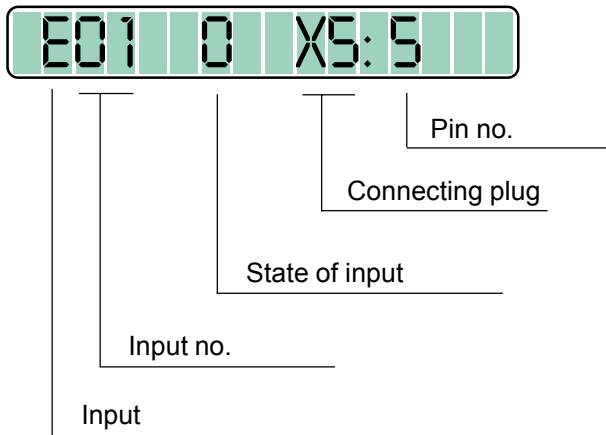

The function assigned to the input displayed can be seen from chapter 12 „Connections Diagram for Connectors“.

The designations E (for input) are located on the lefthand side of the connectors shown.

The keys or selectors assigned to the inputs are designated S in the connections diagram and have the same numbers as the associated inputs, i.e.

key S1 is connected to input E1

key S2 is connected to input E2

key Sx is connected to input Ex.

The operating state of the input is signalled in the 7th digit of the display.

Key/switch open → display: 0

Key/switch closed → display: 1

In the righthand part of the display, the connecting plug and the pin number to which the displayed input is connected are shown for the purpose of reference.

### Test block 2: Outputs

Display:

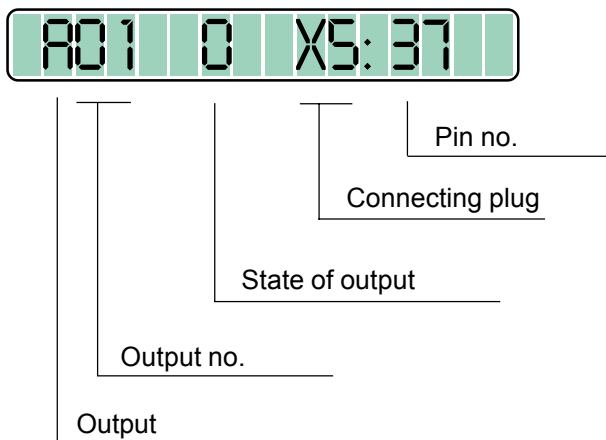

The function assigned to the output displayed can be seen from chapter 12 „Connections Diagram for Connectors“.

The designations A (for output) are located on the lefthand side of the connectors shown.  
The solenoids/solenoid valves assigned to the outputs are designated Y in the connections diagram and have the same numbers as the associated outputs, i.e.  
solenoid Y2 is connected to output A2  
solenoid Y3 is connected to output A3  
solenoid Yx is connected to output Ax

The operating state of the output displayed is signalled in the 7th digit of the display.  
Output not activated → display: 0  
Output activated → display: 1

To activate an output, use key D+. Deactivation is made automatically after approx. 2.5 secs have elapsed or can be caused by using key D-.

In the righthand part of the display, the connecting plug and the pin number to which the displayed output is connected are shown for the purpose of reference.

**Test block 3: Speed control unit (SWG)**

Display:



The treadle can be actuated to operate consecutively all 16 steps of the speed control unit.

The following is displayed in digits 6, 7 and 8

-2 / -1 / 0 / +1 / 10 / 20 / ... / 120, when the speed control unit is in proper condition.

**Test block 4: Synchronizer (IWG)**

Display:



This test block permits to check the synchronizer (increment encoder). For this purpose, the shaft of the motor is rotated manually.

The increments (pulses) of the synchronizer are counted and shown in display digits 7, 8 and 9. This display runs from 0 through 127 when the synchronizer is in proper condition.