



Данную детализировку для вас
предоставила компания **Крунз**

**SUNSTAR MACHINERY CO., LTD.****HEAD OFFICE**

178-212, GAJWA-DONG, SEO-KU, INCHON, KOREA
TEL : (032) 580 - 5600 ~ 4 FAX : (032) 584 - 3020

TRADE OFFICE

178-212, GAJWA-DONG, SEO-KU, INCHON, KOREA
TEL : (032) 580 - 5740 ~ 60 FAX : (032) 584 - 3025 ~ 6

OVERSEAS NETWORK**SUNSTAR MACHINERY U.S.A., INC.**

11475, N.W. 39TH ST. Miami, Florida 33178, USA
TEL : 1-305-591-9596 FAX : 1-305-591-0661

SUNSTAR MACHINERY HONGKONG LTD.

RM. 1302, Apec Plaza, No. 49 Hoi Yuen RD,
Kwun Tong, Kln. H. K.
TEL : 852-2729-7078, 852-2729-7224 FAX : 852-2729-7573

SUNSTAR MACHINERY SHANG HAI LTD. (CHINA)

#7 Yuangong Rd. Shanghai International Automobiles City
Components Sub-Assembly Industrial Zone Jiading Shanghai China
TEL : 86-21-69576305, 69576306 FAX : 86-21-69576091, 69576093

SUNSTAR MACHINERY GUANG DONG BRANCH (CHINA)

Luosha Daxia 12TH Floor 170 Dong Xing-Road, Dong Guan
Shicheng Qu, Guang Dong, China
TEL : 86-769-249-1610 FAX : 86-769-234-4042

SUNSTAR MACHINERY FUJIAN BRANCH (CHINA)

504, Agricultural Bank Building Shishi Fujian, China
TEL : 86-595-859-8871 FAX : 86-595-859-8872

SUNSTAR MACHINERY QINGDAO BRANCH (CHINA)

Chengyangqu Liutingzhen Chongyanglu Shoufeizhan
Beiduan Shangpinlou Qingdao Shandong, China
TEL : 86-532-482-2236, 86-532-481-1262 FAX : 86-532-481-1262

SUNSTAR MACHINERY JAKARTA BRANCH

JL. Pelepah Indah Raya Bloc LC 2/2 Kelapa Gading Permai
Jakarta(14250) Indonesia
TEL : 62-21-450-2143, 62-21-4584-0752 FAX : 62-21-4584-0214

SUNSTAR MACHINERY HOCHIMINH BRANCH (VIETNAM)

#E23 Nguyen Thai Binh ST. W. 12 Tan Binh District,
Hochiminh City, Vietnam
TEL : 84-8-811-4141 FAX : 84-8-811-4588

SUNSTAR MACHINERY HANOI BRANCH (VIETNAM)

19 Son Tay. W. Dien Bien Ba Dinh Dist., Hanoi, Vietnam
TEL : 84-4-734-0268 FAX : 84-4-734-0278

WEB-SITE

<http://www.sunstar.co.kr>

E-MAIL

sunstar@sunstar.co.kr
swf@sunstar.co.kr
fortuna@sunstar.co.kr

PARTS BOOK

KM-380/B

실린더 베드형 고속 1본침 본봉

총합송/바인더 부착형 재봉기

High Speed, Cylinder Bed, 1-Needle,

Unison Feed Lock Stitch M/C W/Binder



Компания „Крунг“

тел./факс: (495) 989-22-97 www.krung.ru



CONTENTS

목 차

A	<i>Machine Body & Thread Tension Adjusting Mechanism</i> 외장 및 실장력 조절 관계.....	4
B	<i>Upper Shaft & Needle Bar & Upright Shaft & Lower Shaft Mechanism</i> 상축/바늘대 및 입축/하축 관계.....	6
C	<i>Presser Bar & Upper Feed & Knee Lifting Mechanism</i> 누름대/상피이드 및 무릎올림 관계.....	10
D	<i>Lower Feed Mechanism</i> 하 피이드 관계.....	12
E	<i>Lubrication</i> 급유 관계.....	14
F	<i>Accessories</i> 액세서리 관계.....	16

Machine Body & Thread Tension Adjusting Mechanism 외장 및 실장력 조절 관계

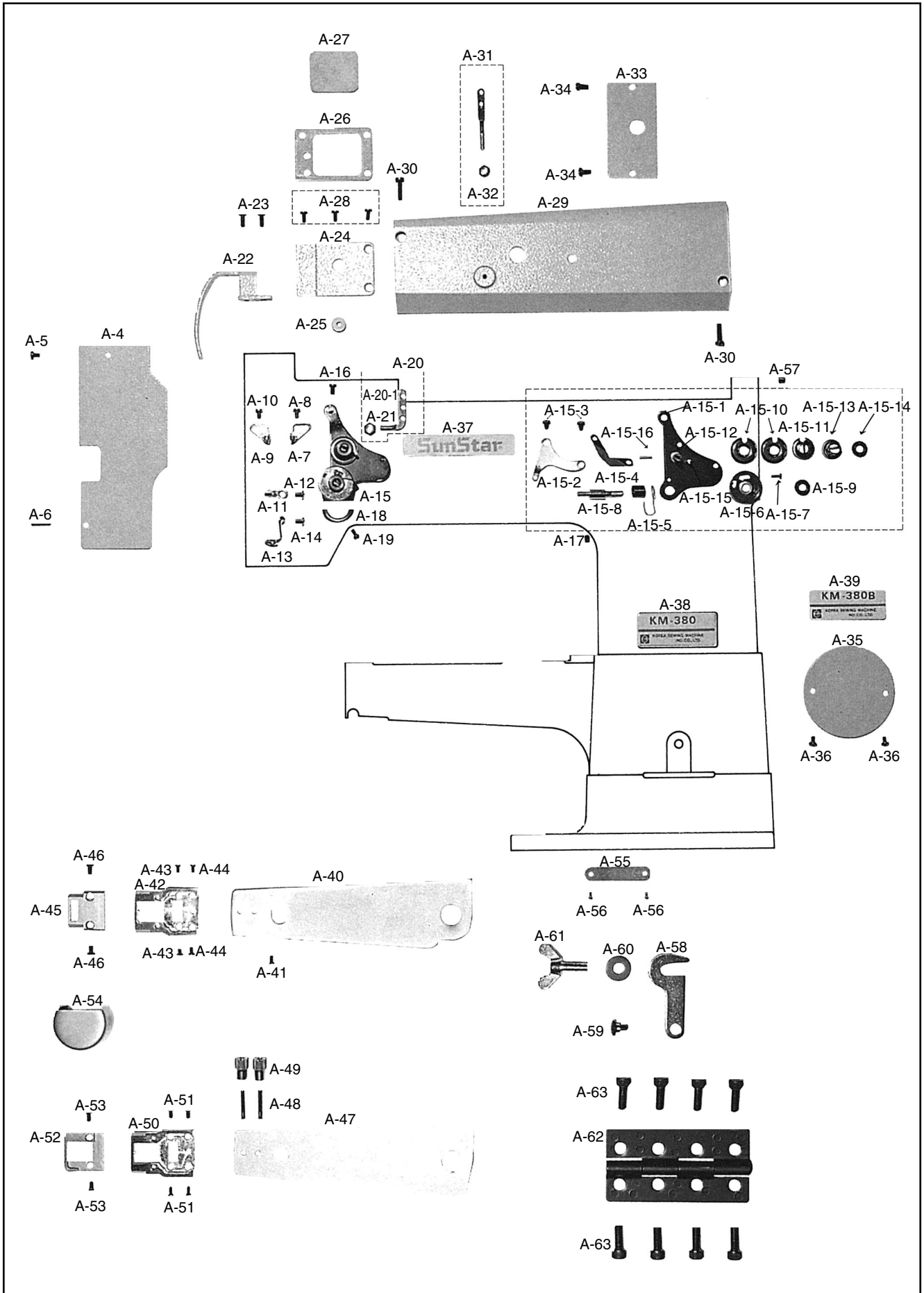



Ref. No.	Parts No.	Note	Name of Parts	품명	Q'ty	Assembly No.
A-1	01-002A-380A		Arm	암	1	
A-2	01-003A-380A		Cylindrical Bed	베드	1	
A-3	01-004A-380A		Base	베이스	1	
A-4	01-011A-3800		Face Plate	면판	1	
A-5	SC-0365-4118		Screw (9/64" n=40)	홈이 냄비 작은나사(9/64" n=40)	1	
A-6	01-030C-3800		Lock Pin For Face Plate	면판 고정핀	1	
A-7	01-024A-3800		Arm Thread Guide (A)	암실안내 (A)	1	
A-8	SC-0120-1230		Screw (9/64" n=40)	오일펌프카바나사(9/64" n=40)	1	
A-9	01-025A-3800		Arm Thread Guide (B)	암실안내 (B)	1	
A-10	SC-0120-1230		Screw (9/64" n=40)	오일펌프카바나사(9/64" n=40)	1	
A-11	01-026A-3800		Arm Thread Guide (C)	암실안내 (C)	1	
A-12	SC-0120-1230		Screw (9/64" n=40)	오일펌프카바나사(9/64" n=40)	1	
A-13	01-027A-3800		Arm Thread Guide (D)	암실안내 (D)	1	
A-14	SC-0120-1230		Screw (9/64" n=40)	오일펌프카바나사(9/64" n=40)	1	
A-15	40-001A-3800		Thread Tension Adjusting Equipment Ass'y	실조절 장치	1Set	
A-15-1	40-101A-3800		Lower Plate For A-15	실조절 장치 몸체	1	
A-15-2	40-104A-3800		Thread Tension Release Plate	실조절 장치 잠이판	1	
A-15-3	40-103S-3800		Set Screw For A-15-2	실조절 장치 쥘나사	2	
A-15-4	40-102A-3800		Spring For A-15-2	실조절 장치 스프링	1	
A-15-5	40-111G-3800		Thread Take-Up Lever Spring	뽕뽕 스프링 (KM-380)	1	
A-15-6	40-105A-3800		Guide For A-15-5	실조절 받침	1	
A-15-7	40-106A-3800		Stopper Screw A-15-6	실조절 받침 쥘나사	1	
A-15-8	40-111A-3800		Thread Adjusting Equipment Shaft	실조절 장치 축(대)	1	
A-15-9	40-108A-3800		Nut For A-15-8	실조절 장치 조절너트	1	
A-15-10	40-109A-3800		Disc For Thread Guide	실조절 접시	2	
A-15-11	40-110A-3800		Pushing Plate For A-15-10	실조절 스프링 받침	1	
A-15-12	40-107A-3800		Adjusting Shaft For Thread Tension	실조절 장치 축(소)	1	
A-15-13	40-333G-3800		Adjusting Spring For Thread Tension	소라 스프링 (KM-380)	1	
A-15-14	40-108A-3800		Nut For A-15-12	실조절 장치 조절너트	1	
A-15-15	40-112A-3800		Stopper Pin For A-15-10	실조절 고정핀(1)	1	
A-15-16	40-113A-3800		Pin For A-15-1	실조절 고정핀(2)	1	
A-16	SC-0175-1230		Screw (11/64" n=40)	실채기카바나사(11/64" n=40)	1	
A-17	SC-0352-7400		Screw (3/16" n=28)	가마축부싱쥘나사(3/16" n=28)	1	
A-18	01-019C-7400		Stopper For A-15-15	실조절 장치 스톱퍼	1	
A-19	SC-0502-2302		Screw (9/64" n=40)	윗뚜껑 고정판 고정나사(대) (11/64" n=40)	1	
A-20	01-127A-1230		Three Hole Thread Guide Eyelet	세구멍 실걸이(조)	1	
A-20-1	01-015A-1230		Three Hole Thread Guide Eyelet	세구멍 실걸이	1	
A-21	01-027C-1230		Nut For A-20	세구멍 실걸이 너트	1	
A-22	01-019A-3800		Cover For Take-Up Lever	실채기 커버	1	
A-23	SC-0179-3710		Screw (11/64" n=40)	윗뚜껑 쥘나사(11/64" n=40)	2	
A-24	01-017A-3800		Oil Tank Cover For Thread Take-Up Lever	실채기 급유 탱크 커버	1	
A-25	01-007R-8130		Oil Tank Plug For Thread Take-Up Lever	고무 마개(Hole)	1	
A-26	01-018M-3800		Oil Tank Packing For Thread Take-Up Lever	실채기 급유 탱크 패킹	1	
A-27	44-008M-3800		Oil Tank Felt For Thread Take-Up Lever	실채기 급유 felt	1	
A-28	SC-0175-1230		Screw (11/64" n=40)	실채기카바나사(11/64" n=40)	3	
A-29	01-016A-3800		Top Cover	윗뚜껑	1	
A-30	SC-0498-3710		Screw (11/64" n=40)	가마잡이나사(11/64" n=40)	2	
A-31	01-116A-2350		Upper Thread Guide Pin	실안내봉	1	
A-32	01-027C-1230		Set Screw For A-31	세구멍 실걸이 너트	1	
A-33	01-012A-3800		Rear Cover	뒷 뚜껑	1	
A-34	SC-0365-3710		Screw (3/16" n=32)	면판측면카바나사(하) (3/16" n=32)	2	
A-35	01-007A-3800		Lower Shaft Cover	하축커버	1	
A-36	SC-0365-3710		Screw (9/64" n=40)	면판측면카바나사(하) (9/64" n=40)	2	
A-37	01-010M-2350		Brand Mark	상표 마크(암부)	1	
A-38	01-029A-380A	A	Model Mark	모델마크	1	
A-39	01-029M-380B	B	Model Mark	모델마크	1	
A-40	01-013A-380A	A	Bed Cover Ass'y	베드 커버(조)	1	
A-41	SC-0505-3710	A	Screw (9/64" n=40)	면판측면카바나사(상) (9/64" n=40)	1	
A-42	01-022A-380A	A	Base For A-45	바늘판 받침	1	
A-43	SC-0309-3800	A	Screw (9/64" n=40)	바늘판 받침 쥘나사 A (9/64" n=40)	2	
A-44	SC-0309-3800	A	Screw (9/64" n=40)	접시 머리 볼트(9/64" n=40)	2	
A-45	01-020A-380A	A	Needle Plate	바늘판	1	
A-46	SC-0189-380A	A	Screw (11/64" n=40)	바늘판쥘나사(11/64" n=40)	2	
A-47	01-013A-380B	B	Bed Cover Ass'y	베드커버(조)	1	
A-48	20-002A-380B	B	Binder Supporting Screw	랍빠고정 볼트	2	
A-49	20-002C-380B	B	Binder Supporting Screw Nut	랍빠고정 너트	2	
A-50	01-022A-380B	B	Base For A-52	바늘판 받침	1	
A-51	SC-0145-3800	B	Screw (9/64" n=40)	바늘판 받침 쥘나사 B(9/64" n=40)	4	
A-52	01-020A-380B	B	Needle Plate	바늘판	1	
A-53	SC-0501-2302	B	Screw (11/64" n=40)	실채기카바나사(11/64" n=40)	2	
A-54	01-015A-3800		Hook Cover	훅 커버	1	
A-55	01-034M-7400		Machine Number Plate	번호판	1	
A-56	01-035P-7400		Setting Pin For A-55	번호판 핀	2	
A-57	01-015C-3400		Oil Hole Plug For Main Shaft Bushing (Rear)	상축 후부싱 급유 구멍마개	1	
A-58	01-008A-3800		Latch	두부 고정쇠	1	
A-59	43-004S-3400		Hinge Screw For A-58	무릎 올림봉 단나사	1	
A-60	01-010C-3800		Washer For A-58	두부 고정와셔	1	
A-61	01-009A-3800		Thumb Screw For A-58	두부 고정 나비볼트	1	
A-62	01-005A-380A		Bed Hinge Ass'y	베드힌지(조)	1	
A-63	SC-0325-3800		Screw(M8×1.25)	베드힌지쥘나사(M8×1.25)	8	

NOTE:

A=KM-380A
B=KM-380B

Upper Shaft & Needle Bar & Upright Shaft & Lower Shaft Mechanism

상축/바늘대 및 입축/하축 관계

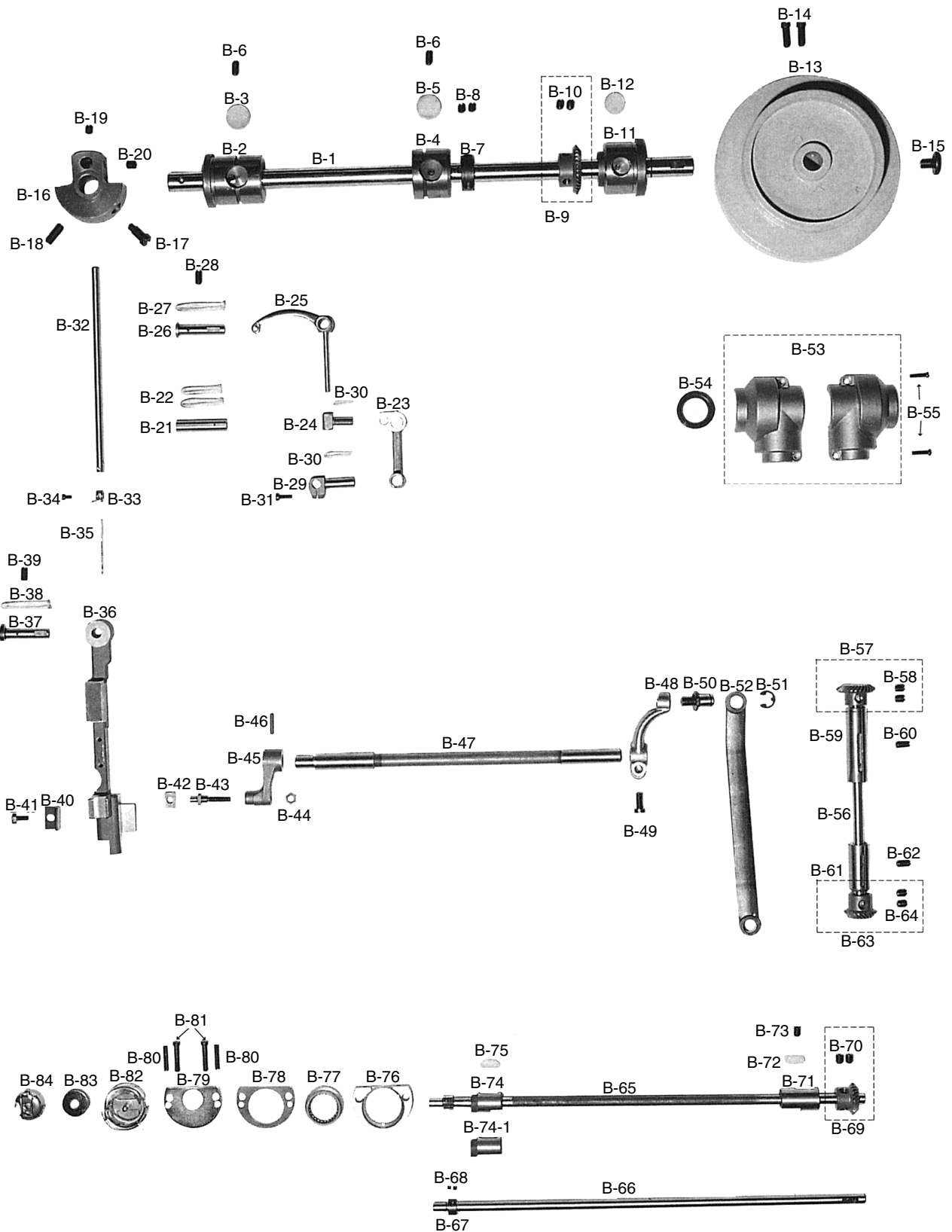



Ref. No.	Parts No.	Note	Name of Parts	품 명	Q' ty	Assembly No.
B-1	02-101A-3800		Main Shaft	상축	1	
B-2	02-104A-3800		Front Bushing For B-1	상축 앞 붓싱	1	
B-3	02-009M-7400		Oil Felt For B-2	상축 앞 붓싱 헬트	1	
B-4	02-105A-3800		Center Bushing For B-1	상축 중 붓싱	1	
B-5	02-009M-7400		Oil Felt For B-4	상축 앞 붓싱 헬트	1	
B-6	SC-0507-1230		Screw (15/64" n=28)	상축붓싱고정나사(15/64" n=28)	2	
B-7	02-121A-1230		Main Shaft Collar	상축 카라	1	
B-8	SC-A129-4515		Screw (1/4" n=40)	홈볼이 멈춤나사(1/4" n=40)	2	
B-9	02-211A-1230		Main Shaft Gear	상축기어(국산)	1	
B-10	SC-A129-4515		Screw (1/4" n=40)	홈볼이 멈춤나사(1/4" n=40)	2	
B-11	02-106A-3800		Rear Bushing For B-1	상축 후 붓싱	1	
B-12	44-006M-3800		Oil Felt For B-11	상축 후 붓싱 급유 헬트	1	
B-13	02-006A-3400		Pulley	폴리	1	
B-14	SC-0150-2500		Screw (15/64" n=28)	폴리고정나사(15/64" n=28)	2	
B-15	SC-0188-1230		Screw (5/16" n=24)	폴리큰나사(5/16" n=24)	1	
B-16	02-102A-3800		Counterweight	링크캠	1	
B-17	SC-0535-3710		Screw (9/32" n=28)	링크캠휼나사(대) (9/32" n=28)	1	
B-18	SC-0148-2302		Screw (9/32" n=28)	링크캠휼나사(B) (9/32" n=28)	1	
B-19	SC-A129-4515		Screw (1/4" n=40)	홈볼이 멈춤나사(1/4" n=40)	1	
B-20	SC-0504-1230		Screw (1/4" n=40)	실채기핀고정나사(1/4" n=40)	1	
B-21	04-005A-3800		Shaft For B-23	바늘대 크랭크 축	1	
B-22	44-0000-1230		Oil Wick	유심	1	
B-23	04-008A-5607		Crank For B-32	바늘대 크랭크	1	
B-24	02-103A-7400		Holder For B-25	실채기 잡이	1	
B-25	08-101A-3800		Thread Take-Up Lever	실채기	1	
B-26	08-002A-3800		Hinge Pin For B-25	실채기 힌지핀	1	
B-27	44-0000-1230		Oil Wick	유심	1	
B-28	SC-0507-1230		Screw (15/64" n=28)	상축붓싱고정나사(15/64" n=28)	1	
B-29	04-103A-3800		Needle Bar Holder	바늘대 잡이	1	
B-30	44-0000-1230		Oil Wick	유심	2	
B-31	SC-0158-3710		Screw (9/64" n=40)	면판휼나사(9/64" n=40)	1	
B-32	04-101A-3800		Needle Bar	바늘대	1	
B-33	04-002A-3800		Thread Guide For B-32	바늘대 실안내	1	
B-34	SC-A131-4522		Screw (1/8" n=44)	홈볼이 납작 작은나사(1/8" n=44)	1	
B-35			Needle	바늘	1	
B-36	15-029A-3800		Needle Bar Frame	바늘대 후레임	1	
B-37	15-030P-3800		Hinge Pin For B-36	바늘대 후레임 힌지핀	1	
B-38	44-0000-1230		Oil Wick	유심	1	
B-39	SC-0507-1230		Screw (15/64" n=28)	상축붓싱고정나사(15/64" n=28)	1	
B-40	15-031A-3800		Guide For B-36	바늘대 후레임 안내	1	
B-41	SC-0180-3800		Screw (11/64" n=40)	바늘대 후레임 안내휼나사(11/64" n=40)	1	
B-42	15-128A-3800		Block For B-36	바늘대 후레임 블럭	1	
B-43	15-027A-3800		Shaft For B-42	바늘대 후레임 블럭 축	1	

NOTE:

A=KM-380A
 B=KM-380B

Upper Shaft & Needle Bar & Upright Shaft & Lower Shaft Mechanism

상축/바늘대 및 입축/하축 관계

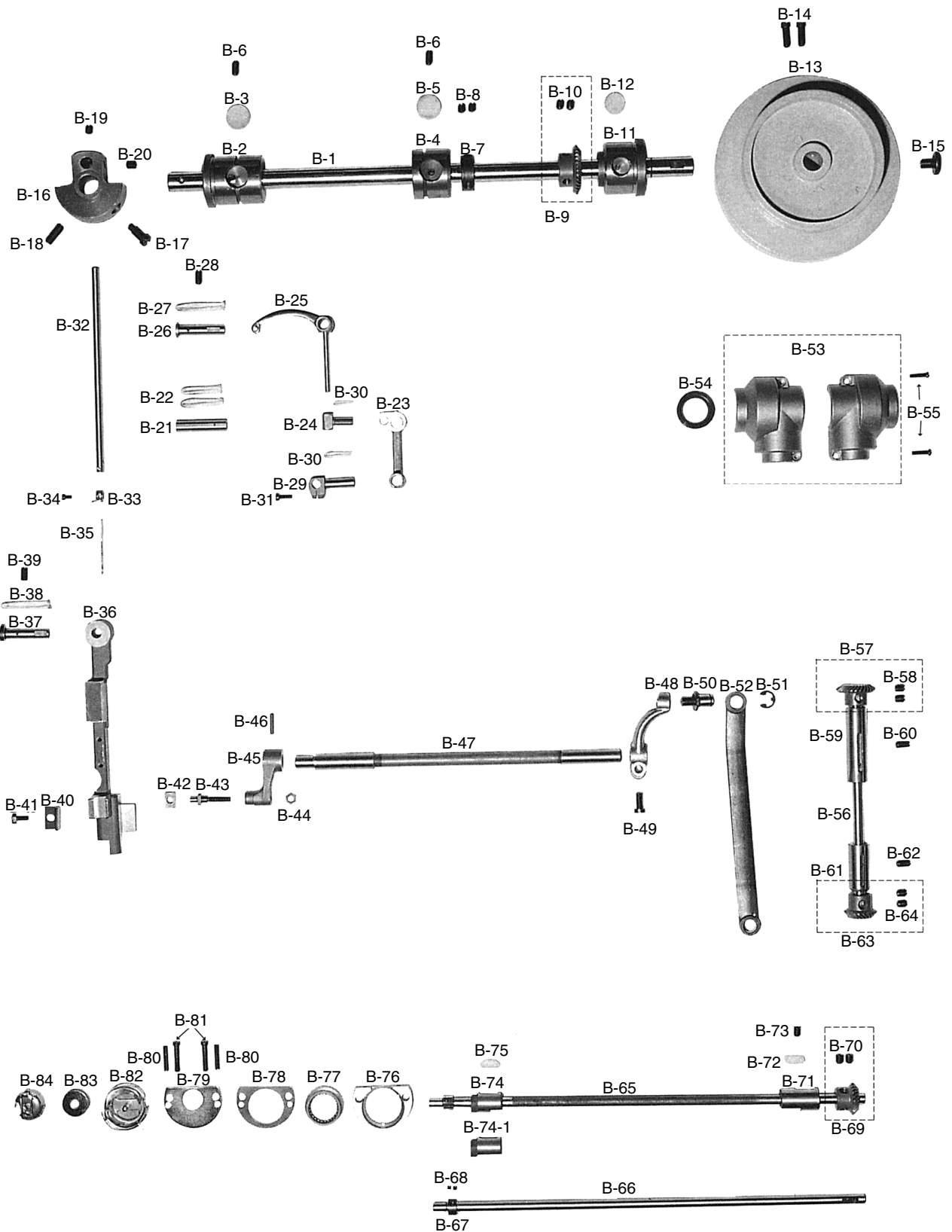



Ref. No.	Parts No.	Note	Name of Parts	품 명	Q' ty	Assembly No.
B-44	SN-0115-7400		Nut (3/16" n=32)	오프너 너트(3/16" n=32)	1	
B-45	15-025A-3800		Driving Shaft Crank (Front)	요동축 크랭크(전)	1	
B-46	15-026P-3800		Fixed Pin For B-45	요동축 크랭크(전) 고정핀	1	
B-47	15-124A-3800		Needle Bar Frame Driving Shaft	바늘대 후레임 요동축	1	
B-48	15-123A-3800		Driving Shaft Crank (Rear)	요동축 크랭크(후)	1	
B-49	SC-0500-7400		Screw (15/64" n=28)	포크칩나사(15/64" n=28)	1	
B-50	06-020S-3800		Stud For B-52	수평밀대 크랭크 연결단나사	1	
B-51	06-003C-7400		E-Ring For B-50	피이드 조절기 힌지핀 E링(φ7)	1	
B-52	15-122A-3800		Driving Shaft Connecting Rod	요동축 연결로드	1	
B-53	44-001A-3800		Gear Case Ass'y	기어 케이스(조)	1	
B-54	03-013R-3710		Oil Seal (B)	오일씸(B)	1	
B-55	SC-0528-1230		Screw (9/64" n=40)	카바나사(우) (9/64" n=40)	2	
B-56	03-011A-3800		Upright Shaft	입축	1	
B-57	02-212A-1230		Upright Shaft Upper Gear	입축 상기어(국산)	1	
B-58	SC-A129-4515		Screw (1/4" n=40)	홈볼이 멈춤나사(1/4" n=40)	2	
B-59	03-102A-3800		Upper Bushing For B-56	입축 상붓싱	1	
B-60	SC-0507-1230		Screw (15/64" n=28)	상축붓싱고정나사(15/64" n=28)	1	
B-61	03-103A-3800		Lower Bushing For B-56	입축 하붓싱	1	
B-62	SC-0507-1230		Screw (15/64" n=28)	상축붓싱고정나사(15/64" n=28)	1	
B-63	02-213A-1230		Upright Shaft Lower Gear	입축 하기어(국산)	1	
B-64	SC-A129-4515		Screw (1/4" n=40)	홈볼이 멈춤나사(1/4" n=40)	2	
B-65	07-001A-380A	A	Lower Shaft	하축	1	
B-66	07-101A-380B	B	Lower Shaft	하축	1	
B-67	07-003A-380B	B	Collar For B-66	하축 카라	1	
B-68	SC-0111-380B	B	Screw (9/64" n=40)	테이프안내칩나사(9/64" n=40)	2	
B-69	02-214A-1230		Lower Shift Gear	하축 뒷기어(국산)	1	
B-70	SC-A129-4515		Screw (1/4" n=40)	홈볼이 멈춤나사(1/4" n=40)	1	
B-71	07-003A-3800		Rear Bushing For B-65	하축 뒷붓싱	1	
B-72	44-007M-3800		Oil Felt For B-71	하축 앞붓싱 급유 헬트	1	
B-73	SC-0507-1230		Screw (15/64" n=28)	상축붓싱고정나사(15/64" n=28)	1	
B-74	07-002A-380A	A	Front Bushing For B-65	하축 앞붓싱	1	
B-74-1	07-002A-380B	B	Front Bushing For B-65	하축 앞붓싱	1	
B-75	44-007M-3800		Oil Felt For B-65	하축 앞붓싱 급유 헬트	1	
B-76	06-140A-3800	A	Holder(A) For B-77	상하 운동 캠 잡이(A)	1	
B-77	06-039A-3800	A	Feed Driving Cam	하축 캠	1	
B-78	06-141A-3800	A	Holder(B) For B-77	상하 운동 캠 잡이(B)	1	
B-79	06-042A-3800	A	Cover For B-78	상하 운동 캠 잡이(C)	1	
B-80	06-043C-3800	A	Stopper Pin For B-78	상하 운동 캠 잡이 스톱퍼(4×20)	2	
B-81	SC-0335-3800	A	Screw (3/16" n=32)	상하운동캠잡이나사(3/16" n=32)	2	
B-82	07-004A-3800		Rotary Hook Ass'y	가마	1	
B-83	07-105A-2700		Bobbin	보빈	1	
B-84	07-005A-3800		Bobbin Case	보빈 케이스	1	

NOTE:

A=KM-380A
 B=KM-380B



Presser Bar & Upper Feed & Knee Lifting Mechanism

누름대/상피이드 및 무릎올림 관계

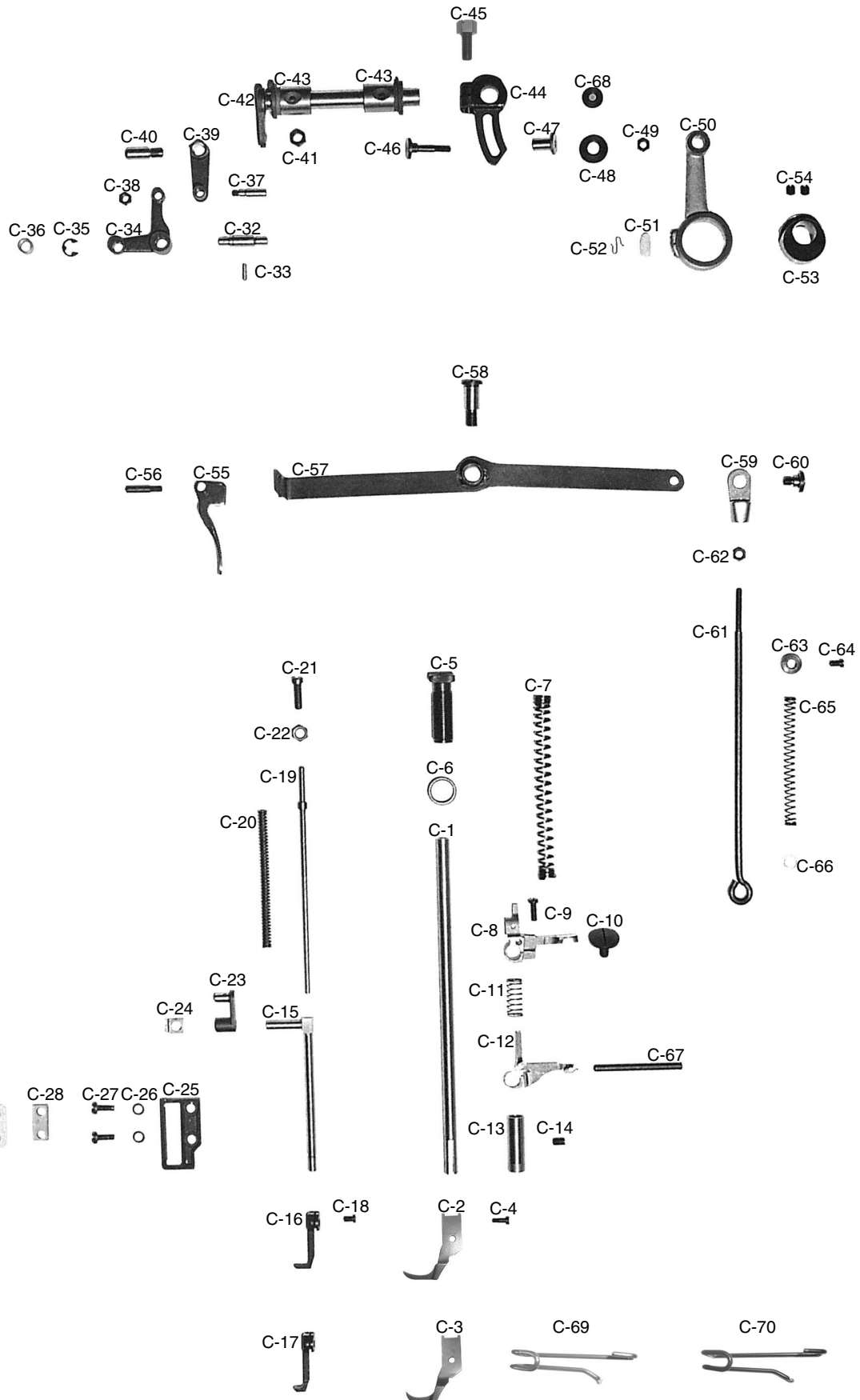



Ref. No.	Parts No.	Note	Name of Parts	품 명	Q' ty	Assembly No.
C-1	05-302A-3800		Presser Bar	누름대	1	
C-2	05-101A-380A	A	Sub Presser Foot	노루발	1	
C-3	05-101A-380B	B	Sub Presser Foot	노루발	1	
C-4	SC-0315-2302		Screw (9/64" n=40)	노루발캡나사(9/64" n=40)	1	
C-5	SC-0367-3400		Screw (9/16" n=20)	압력조절나사(9/16" n=20)	1	
C-6	SN-0100-3400		Nut (9/16" n=20)	압력조절나사너트(9/16" n=20)	1	
C-7	05-004A-3800		Presser Regulation Spring	압력조절 스프링	1	
C-8	05-102A-3800		Presser Bar Bracket	누름대 브라켓	1	
C-9	05-005S-1230		Presser Bar Guide Bracket	누름대 잡이 나사	1	
C-10	05-005S-7400		Hold Stud For C-8	누름대 올리기 단나사	1	
C-11	40-004G-3800		Return Spring For C-12	실늑추기 리턴 스프링	1	
C-12	40-002A-3800		Thread Tension Release Ass'y	실늑추기(조)	1	
C-13	05-109A-3800		Bushing For C-1	누름대 붓싱	1	
C-14	SC-0509-1230		Screw (15/64" n=28)	피이드캠고정나사(15/64" n=28)	1	
C-15	15-115A-3800		Upper Feed Presser Bar	상피이드 노루발대	1	
C-16	15-033A-380A	A	Upper Feed Presser Foot	상피이드 노루발	1	
C-17	15-033A-380B	B	Upper Feed Presser Foot	상피이드 노루발	1	
C-18	SC-0128-7400		Screw (11/64" n=40)	인봉카라캡나사(11/64" n=40)	1	
C-19	15-018A-3800		Pressure Adjusting Pole Ass'y	상피이드 노루발 압력봉	1	
C-20	15-019G-3800		Pressure Spring For C-16	상피이드 노루발 압력 스프링	1	
C-21	SC-0343-3800		Screw (15/64" n=28)	상피이드 노루발압력 조절나사(15/64" n=28)	1	
C-22	SN-0105-3400		Nut (15/64" n=28)	수평운동 롯드단나사너트(15/64" n=28)	1	
C-23	15-114A-3800		Driving Link For C-16	상피이드 운동링크	1	
C-24	15-117A-3800		Guide Block For C-15	상피이드 노루발 안내블럭	1	
C-25	15-123A-5607		Guide Plate For C-15	노루발대 안내판(K2555)	1	
C-26	01-017W-1600		Washer For C-27	윗뚜껑 겹와셔	2	
C-27	SC-0174-1230		Screw (11/64" n=40)	가마잡이나사(11/64" n=40)	2	
C-28	05-006A-3800		Guide For C-34	로올러 안내	1	
C-29	05-008C-3800		Roller Guide Frame	로올러 안내 후레임	1	
C-30	01-023C-3710		Washer For C-29	와셔(φ5)	2	
C-31	SC-0307-1230		Screw (3/16" n=32)	톱니반침 크랭크캡나사(3/16" n=32)	4	
C-32	05-003A-3800		Roller Shaft For C-8	누름대 브라켓 로올러 축	1	
C-33	05-004P-3800		Fixed Pin For Roller Shaft	로올러축 고정핀	1	
C-34	15-112A-3800		Connecting Link For C-16	상피이드 노루발 연결링크	1	
C-35	06-020C-7400		E-Ring (φ6)	E링(φ6)	1	
C-36	05-005A-3800		Roller For C-8	누름대 브라켓 로올러	1	
C-37	15-013A-3800		Shaft For C-34	상피이드 노루발 연결 링크축	1	
C-38	SN-0101-1600		Nut (11/64" n=40)	스프링걸이 축나사너트(11/64" n=40)	1	
C-39	15-110A-3800		Upper Feed Connecting Link	상피이드 연결링크	1	
C-40	15-011S-3800		Stud For C-39	상피이드 연결링크축 나사	1	
C-41	SN-0116-3400		Nut (1/4" n=40)	수평운동조절 축너트(1/4" n=40)	1	
C-42	GP-010500-00		Upper Feed Driving Shaft	상하 운동축	1	
C-43	15-109A-3800		Bushing For C-42	상하 운동축 붓싱	2	
C-44	15-203A-3800		Upper Feed Lifting Adjusting Crank	상하 운동 크랭크	1	
C-45	SC-0140-5607		Screw (1/4" n=24)	상하운동 크랭크캡나사(1/4" n=24)	1	
C-46	15-007A-5607		Upper Feed Lifting Adjusting Shaft	상하 운동 조절축	1	
C-47	15-206A-3800		Bushing For B-46	상하 운동 조절축 붓싱	1	
C-48	11-009A-5607		Washing For C-46	상하 운동 조절축 카라	1	
C-49	SN-0116-3400		Nut (3/16" n=32)	오프너너트(3/16" n=32)	1	
C-50	15-202A-3800		Rod For C-53	상하 운동 캠 롯드	1	
C-51	44-023M-3400		Oil Felt For C-50	노루발 상하운동 캠 롯드 급유 헬트	1	
C-52	44-015C-3400		Oil Felt Holder For C-51	상하운동 캠 롯드 유십잡이	1	
C-53	15-101A-3800		Upper Feed Lifting Eccentric Cam	상하운동 캠	1	
C-54	SC-A129-4515		Screw (1/4" n=40)	홈볼이 멈춤나사((1/4" n=40)	2	
C-55	05-006A-7400		Presser Bar Lifter	누름대 올리기	1	
C-56	05-009P-3800		Hinge Pin For C-55	누름대 올리기 힌지핀	1	
C-57	43-101A-3800		Knee Lifting Lever	무릎 올림 레버	1	
C-58	43-001S-3400		Hinge Screw For C-57	무릎 올림 레버 힌지나사	1	
C-59	43-003A-3400		Connection Holder	무릎 올림봉 잡이	1	
C-60	43-004S-3400		Hinge Screw For C-59	무릎 올림봉 단나사	1	
C-61	43-004A-3800		Knee Lifting Lod	무릎 올림봉	1	
C-62	SN-0119-1230		Nut (3/16" n=28)	제어체운동조절 나사너트(3/16" n=28)	1	
C-63	05-021A-7400		Collar For C-61	무릎 올림봉 카라	1	
C-64	SC-0128-7400		Screw (11/64" n=40)	인봉카라캡나사(11/64" n=40)	1	
C-65	43-003G-3800		Spring For C-57	무릎 올림 레버 스프링	1	
C-66	01-023C-3710		Washer For C-65	와셔(φ5)	1	
C-67	40-003C-3800		Shaft For C-12	실늑추기 축	1	
C-68	15-026W-3400		Washer	상하운동 조절축 와셔	1	
C-69	05-002C-380A		Safety Guard	안전 가이드	1	
C-70	05-002C-380B		Safety Guard	안전 가이드	1	

NOTE:

A=KM-380A
B=KM-380B

Lower Feed Mechanism

하 피이드 관계

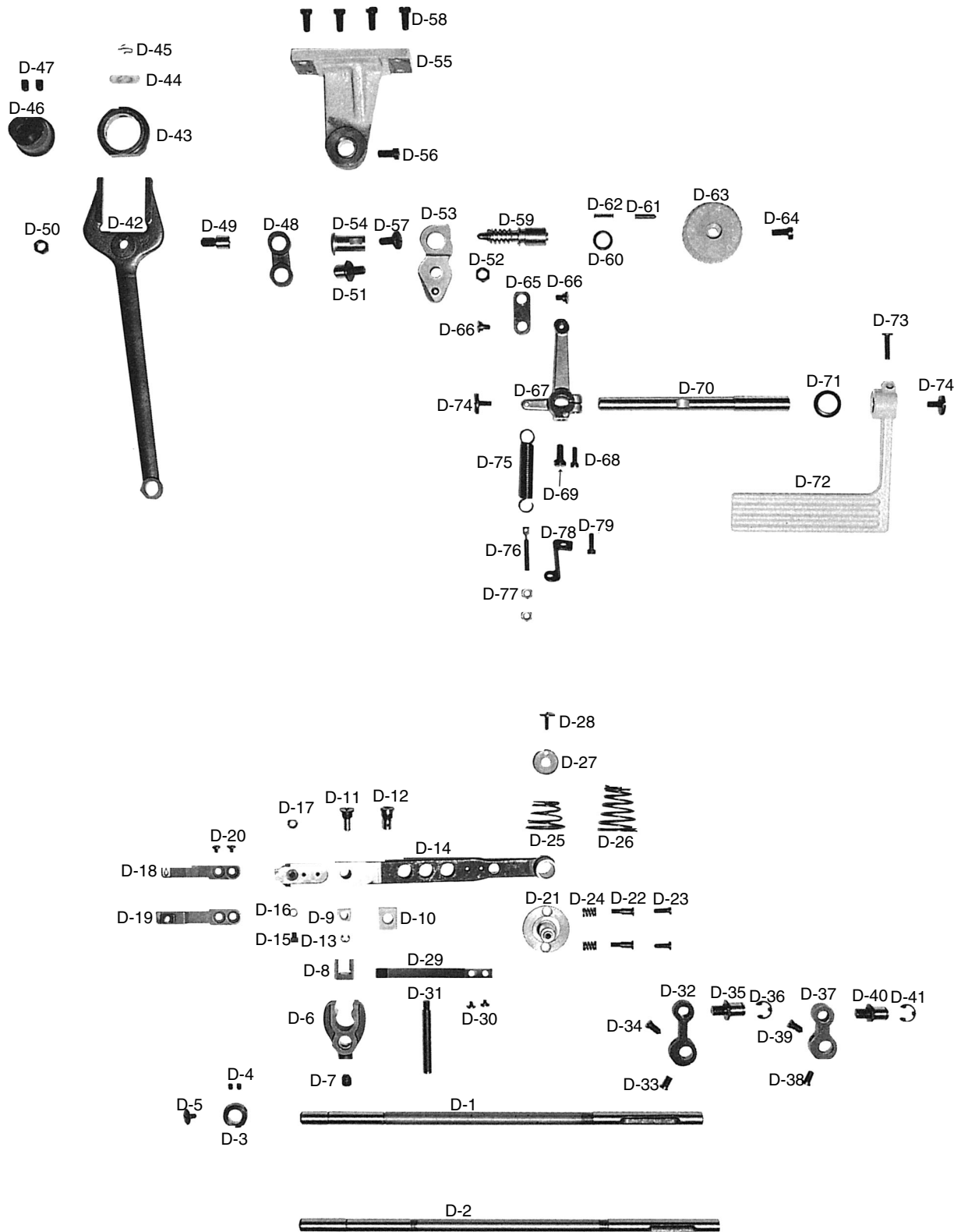



Ref. No.	Parts No.	Note	Name of Parts	품명	Q' ty	Assembly No.
D-1	06-116A-380A	A	Feed Locker Shaft	수평밀대	1	
D-2	06-116A-380B	B	Feed Locker Shaft	수평밀대	1	
D-3	06-018A-3800		Collar For D-1	수평밀대 카라	1	
D-4	SC-0104-5607		Screw (11/64" n=40)	하측중베어링부싱고정나사(11/64" n=40)	2	
D-5	SC-0200-3800		Screw (11/64" n=40)	수평밀대고정나사(11/64" n=40)	1	
D-6	06-021A-3800		Feed Bar Crank	톱니 받침 크랭크	1	
D-7	SC-0201-1230		Screw (5/16" n=24)	상측기름막이 고무고정나사(5/16" n=24)	1	
D-8	06-045A-3800	A	Feed Bar Crank Block	톱니 받침 크랭크 블럭	1	
D-9	06-032A-380A	A	Feed Bar Slide Block(A)	톱니 받침 블럭	1	
D-10	06-032A-380B	B	Feed Bar Slide Block(B)	톱니 받침 블럭	1	
D-11	06-031A-380A	A	Block Stud For D-14	톱니 받침 블럭 축	1	
D-12	06-031A-380B	B	Block Stud For D-14	톱니 받침 블럭 축	1	
D-13	06-033M-3800	A	E-Ring For D-11	톱니 받침 블럭 축 E링(φ3)	1	
D-14	06-023A-3800		Feed Bar	톱니 받침	1	
D-15	06-034C-3800	A	Stopper For D-14	톱니 받침 스톱퍼	1	
D-16	06-036W-3800	A	Feed Dog Adjusting Washer	톱니 높이 조절 와셔	1	
D-17	06-035C-3800	A	Nut For D-15	톱니 받침 스톱퍼 너트	1	
D-18	06-037A-380A	A	Feed Dog	톱니	1	
D-19	06-037A-380B	B	Feed Dog	톱니	1	
D-20	SC-0138-3800		Screw (1/8" n=44)	톱니 쥘나사(1/8" n=44)	2	
D-21	06-024A-3800		Hinge Stud For D-14	톱니 받침 힌지축	1	
D-22	06-025S-3800	A	Screw For D-21	톱니 받침 힌지축 나사	2	
D-23	SC-0179-3710	B	Screw (11/64" n=40)	윗뚜껑정나사(11/64" n=40)	2	
D-24	06-026G-3800	A	Tension Spring For D-21	톱니 받침 힌지축 텐션 스프링	2	
D-25	01-014G-380A	A	Spring For Bed Cover	베드 커버 스프링	1	
D-26	01-014G-380B	B	Spring For Bed Cover	베드 커버 스프링	1	
D-27	06-027W-3800		Washer For D-21	톱니 받침 힌지축 와셔	1	
D-28	SC-0198-3800		Screw (9/64" n=40)	톱니받침힌지축와셔고정나사(9/64" n=40)	1	
D-29	06-029G-3800	A	Feed Bar Bat Spring	톱니 받침 텐션 스프링	1	
D-30	SC-0138-3800	A	Screw (1/8" n=44)	톱니 쥘나사(1/8" n=44)	2	
D-31	06-030A-3800	A	Support Stud For D-29	톱니 받침판 스프링 지지축	1	
D-32	15-121A-3800		Needle Bar Frame Driving Crank	바늘대 후레임 요동 크랭크	1	
D-33	SC-0122-1230		Screw (15/64" n=28)	톱니받침축고정나사(15/64" n=28)	1	
D-34	SC-0330-7400		Screw (15/64" n=28)	역진레바크랭크쥘나사(15/64" n=28)	1	
D-35	06-020S-3800		Stud For D-32	수평밀대 크랭크 연결 단나사	1	
D-36	06-003C-7400		E-Ring For D-35	피이드 조절기 힌지핀 E링(φ7)	1	
D-37	06-119A-3800		Crank For D-1	수평밀대 크랭크	1	
D-38	SC-0122-1230		Screw (15/64" n=28)	톱니받침축고정나사(15/64" n=28)	1	
D-39	SC-0330-7400		Screw (15/64" n=28)	역진레바크랭크쥘나사(15/64" n=28)	1	
D-40	06-020S-3800		Stud For D-37	수평밀대 크랭크 연결 단나사	1	
D-41	06-003C-7400		E-Ring For D-40	피이드 조절기 힌지핀 E링(φ7)	1	
D-42	06-102A-3800		Y-Rod	와이롯드	1	
D-43	06-102A-3400		Connecting Ring For D-42	와이롯드 연결링	1	
D-44	44-018M-3400		Oil Felt For D-43	와이롯드 연결링 급유헬트	1	
D-45	44-015C-3400		Oil Felt Holder For D-44	상하운동 캠 릿드 유심잡이	1	
D-46	06-101A-3800		Feed Cam	피이드 캠	1	
D-47	SC-0509-1230		Screw (15/64" n=28)	피드캠고정나사(15/64" n=28)	2	
D-48	06-107A-3800		Feed Link	피이드 링크	1	
D-49	06-009S-3800		Connecting Stud For D-48	피이드 링크 연결축 나사	1	
D-50	SN-0107-1230		Nut (9/32" n=28)	피드조절기연결단나사너트(9/32" n=28)	1	
D-51	06-008S-3800		Connecting Stud For D-50	피이드 조절기 연결축 나사	1	
D-52	SN-0107-1230		Nut (9/32" n=28)	피드조절기연결단나사너트(9/32" n=28)	1	
D-53	06-003A-3800		Feed Regulator	피이드 조절기(K1465)	1	
D-54	06-005A-3800		Shaft For D-53	피이드 조절기 축	1	
D-55	06-004A-3800		Attach Frame For D-53	피이드 조절기 부착 후레임	1	
D-56	SC-0500-7400		Screw (15/64" n=28)	포크쥘나사(15/64" n=28)	1	
D-57	SC-0534-4125		Screw (15/64" n=28)	롤블이 등근납작 작은나사(15/64" n=28)	1	
D-58	SC-0500-7400		Screw (15/64" n=28)	포크쥘나사(15/64" n=28)	4	
D-59	06-014A-3800		Feed Regulator Dial Shaft	다이알 축	1	
D-60	06-010R-1230		O-Ring For D-59	다이알 축 오링	1	
D-61	06-026P-1230		Feed Regulator Dial Pin	다이알 핀	1	
D-62	06-027G-1230		Feed Regulator Dial Spring	다이알 스프링	1	
D-63	06-015C-3800		Length Control Dial	다이알 문자 지지판	1	
D-64	SC-0193-1230		Screw (3/16" n=28)	다이알핀쥘나사(3/16" n=28)	1	
D-65	16-014C-3710		Connecting Link For D-53	연결링크	1	
D-66	16-015S-3710		Hinge Screw For D-65	연결링크 단나사	2	
D-67	06-111A-3800		Crank For D-58	역진 레버축 크랭크	1	
D-68	SC-0497-1230		Screw (3/16" n=28)	틀레크랭크(전)고정나사(3/16" n=28)	1	
D-69	SC-0500-7400		Screw (15/64" n=28)	포크쥘나사(15/64" n=28)	1	
D-70	06-112A-3800		Shaft For D-72	역진 레버축	1	
D-71	06-053W-1230		Corrugated Washer For D-70	레버 와셔	1	
D-72	06-050A-1230		Reverse Feed Control Lever	역진 레버	1	
D-73	SC-0186-1230		Screw (3/16" n=32)	역진레바고정나사(3/16" n=32)	1	
D-74	SC-0185-1230		Screw (3/16" n=32)	레바덜게나사(3/16" n=32)	2	
D-75	06-013G-3800		Spring For D-72	역진 레버 스프링	1	
D-76	06-040S-1600		Adjusting Screw For D-75	스프링 걸이 축 나사	1	
D-77	SN-0101-1600		Nut (11/64" n=40)	스프링걸이축나사너트(11/64" n=40)	2	
D-78	06-139C-1600		Suspension Bracket	역진 레버 스프링 걸이	1	
D-79	SC-0497-1230		Screw (3/16" n=28)	틀레크랭크(전)고정나사(3/16" n=28)	1	

NOTE:

A=KM-380A
B=KM-380B



Lubrication
급유 관계

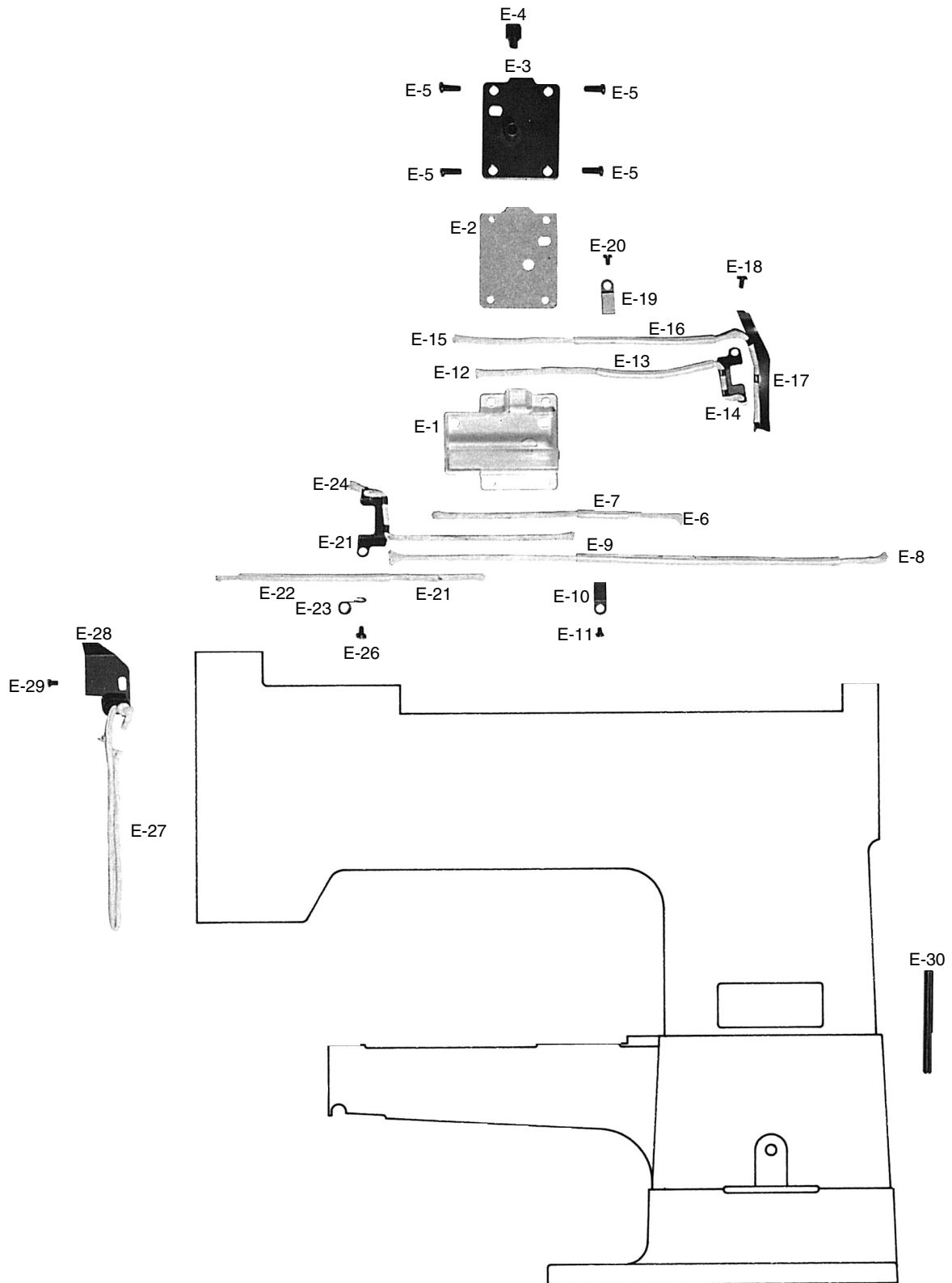



Ref. No.	Parts No.	Note	Name of Parts	품 명	Q' ty	Assembly No.
E-1	44-002A-3800		Oil Tank Ass'y	오일 탱크 (조)	1	
E-2	44-013C-3800		Packing For E-1	오일 탱크 패킹	1	
E-3	44-003A-3800		Pushing Plate Ass'y	오일 탱크 누름판 (조)	1	
E-4	44-012R-7400		Rubber Cap For Oil Tank	주유구 마개	1	
E-5	SC-0179-3710		Screw (11/64" n=40)	윗뚜껑 체결사 (11/64" n=40)	4	
E-6	44-0000-1230		Oil Wick	오일 심지	1	
E-7	44-012C-1230		Oil Return Tube	환류 파이프	1	
E-8	44-0000-1230		Oil Wick	오일 심지	1	
E-9	44-012C-1230		Oil Return Tube	환류 파이프	1	
E-10	44-011C-7400		Oil Wick Holder For E-6, 8	유심헬트 고정판	1	
E-11	SC-0531-2302		Screw (9/64" n=40)	톱카바 고정판 고정나사 (소) (9/64" n=40)	1	
E-12	44-0000-1230		Oil Wick	오일 심지	1	
E-13	44-012C-1230		Oil Return Tube	환류 파이프	1	
E-14	44-004A-3800		Wick Holder For E-13	노루발 상하운동 캠 로드 유심잡이	1	
E-15	44-0000-1230		Oil Wick	오일 심지	1	
E-16	44-012C-1230		Oil Return Tube	환류 파이프	1	
E-17	44-110A-3400		Wick Holder For E-16	피이드링크 유심잡이	1	
E-18	SC-0365-3710		Screw (9/64" n=40)	면판측면 카바나사 (하) (9/64" n=40)	1	
E-19	44-011C-7400		Oil Wick Holder For E-12, 16	유심헬트 고정판	1	
E-20	SC-0531-2302		Screw (9/64" n=40)	톱카바 고정판 고정나사 (소) (9/64" n=40)	1	
E-21	44-0000-1230		Oil Wick	오일 심지	1	
E-22	44-012C-1230		Oil Return Tube	환류 파이프	1	
E-23	44-026G-7400		Oil Wick Holder For E-22	헬트잡이 스프링	1	
E-24	44-0000-1230		Oil Wick	오일 심지	1	
E-25	44-124C-3400		Oil Wick Holder For E-24	와이롯드 연결링 유심잡이	1	
E-26	SC-0531-2302		Screw (9/64" n=40)	톱카바 고정판 고정나사 (소) (9/64" n=40)	1	
E-27	44-0000-1230		Oil Wick	오일 심지	1	
E-28	44-010A-3800		Oil Stopper Plate	면판 유방판	1	
E-29	SC-0531-2302		Screw (9/64" n=40)	톱카바 고정판 고정나사 (소) (9/64" n=40)	1	
E-30	44-009A-3800		Oil Pipe For B-71	하측 후 붓싱 급유 파이프 (6×65)	1	

NOTE:

A=KM-380A
 B=KM-380B

Accessories 액세서리 관계

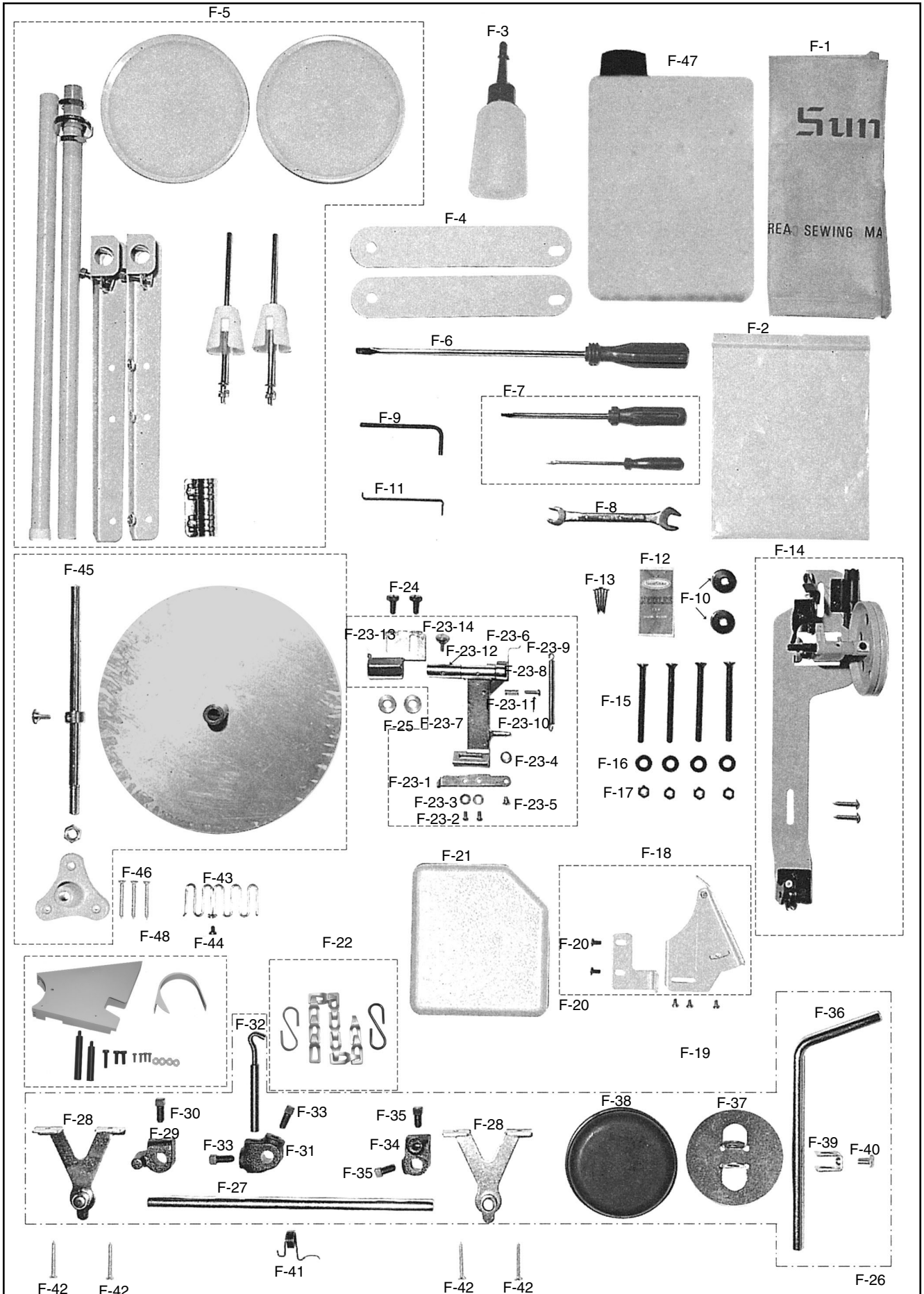



Ref. No.	Parts No.	Note	Name of Parts	품 명	Q' ty	Assembly No.
F-1	91-006C-2700		Head Cover	미싱커버 (대)	1	
F-2	91-001C-1230		Accessory Box	액세서리 박스	1	
F-3	91-011C-1230		Oiler	유차	1	
F-4	91-005R-3800		Cushion Rubber (2)	테이블 결합 쿠션 고무	2	
F-5	91-007A-2302		Thread Stand Ass'y	실패꽃이 (조)	1	
F-6	91-002C-1230		Driver (Large)	드라이버 (대)	1	
F-7	91-003C-1230		Driver (Middle, Small)	드라이버 (중, 소)	1	
F-8	91-002C-3800		Spanner (910)	스패너	1	
F-9	91-001C-3800		L-Wrench (4mm)	렌치 (4mm)	1	
F-10	07-105A-2700		Bobbin	보빈	4	
F-11	91-006C-3800		Spanner	톱니받침 스토퍼 잠금쇠	1	
F-12			Nail	못	5	
F-13			Needle	바늘	1	
F-14	41-101A-1230		Bobbin Winder Ass'y	실감기 (조)	1	
F-15	SC-0143-3800		Screw (M6×1.0)	두부받침 고정볼트 (M6×1.0)	4	
F-16	09-034W-7400		Washer For Locking Bolt	혹받침 와셔	4	
F-17	SN-0102-3800		Nut (M6×1.0)	두부받침 고정너트 (M6×1.0)	4	
F-18	60-101A-3800		Belt Cover Ass'y	벨트커버 (조)	1	
F-19	SC-0120-1230		Screw (9/64" n=40)	오일펌프 카바나사 (9/64" n=40)	3	
F-20	SC-0543-2302		Screw (11/64" n=40)	톱니바퀴 고정나사 (11/64" n=40)	2	
F-21	44-011A-3800		Oil Pan	유수판 (도장품)	1	
F-22	43-105A-3800		Knee Lifting Chain Ass'y	무릎올림줄 (조)	1	
F-23	91-007C-3800	A	Cloth Guide Attachment Ass'y	정규(조)	1Set	
F-23-1	91-112A-3800	A	Cloth Guide	정규	1	
F-23-2	91-113A-3800	A	Set Screw For F-23-1	정규나사	2	
F-23-3	91-114A-3800	A	Washer For F-23-2	정규와셔	2	
F-23-4	91-101A-3800	A	Guide Roller	정규 로올러	1	
F-23-5	91-102A-3800	A	Stud For F-23-4	정규 로올러 단나사	1	
F-23-6	91-105A-3800	A	Attach Body For F-23-1	정규 몸체 브라켓	1	
F-23-7	91-103A-3800	A	Stopper For F-23-6	정규 몸체 스토퍼 브라켓	1	
F-23-8	91-106A-3800	A	Stopper Set Pin	스토퍼 핀	1	
F-23-9	91-104A-3800	A	Return Spring	정규 인장 스프링	1	
F-23-10	91-107A-3800	A	Adjusting Screw For F-23-1	스프링 걸이 나사	1	
F-23-11	91-108A-3800	A	Spring For F-23-1	정규 완충 스프링	1	
F-23-12	91-109A-3800	A	Connecting Shaft For F-23	정규 브라켓 축	1	
F-23-13	91-110A-3800	A	Adjusting Guide For F-23-1	정규 브라켓커버	1	
F-23-14	91-115A-3800	A	Adjusting Screw For F-23-1	정규 브라켓커버 단나사	1	
F-24	SC-0500-7400	A	Screw (15/64" n=28)	포크젯나사(15/64" n=28)	2	
F-25	91-002W-7600	A	Washer For F-24	정규 겹나사 와셔	2	
F-26	43-006A-3800		Knee Lifting Support Ass'y	무릎받침 (조)	1	
F-27	43-107C-3800		Knee Lifting Shaft	무릎받침 축	1	
F-28	43-108C-3800		Bracket For F-24	무릎올림축 브라켓	2	
F-29	43-109C-3800		Knee Lifting Stopper	무릎올림 스토퍼	1	
F-30	SC-0181-1230		Screw (5/16" n=18)	무릎받침축 고정나사 (5/16" n=18)	1	
F-31	43-113C-3800		Crank For F-29	무릎올림축 연결쇠 크랭크	1	
F-32	43-112C-3800		Knee Lifting Chain Connection Loop	무릎올림축 연결쇠	1	
F-33	SC-0181-1230		Screw (5/16" n=18)	무릎받침축 고정나사 (5/16" n=18)	2	
F-34	43-118C-3800		Connecting Crank For F-26	무릎받침축 연결쇠 크랭크	1	
F-35	SC-0181-1230		Screw (5/16" n=18)	무릎받침축 고정나사 (5/16" n=18)	2	
F-36	43-111C-3800		Knee Support Shaft	무릎올림축	1	
F-37	43-103C-3800		Holder Plate For F-36	무릎받침 고무잡이 판	1	
F-38	43-101R-3800		Knee Support Rubber	무릎받침 고무	1	
F-39	43-105C-3800		Holder For F-35	무릎받침 고무잡이 판 홀더	1	
F-40	43-108S-1230		Fixed Screw F-37	무릎받침 연결링크 겹나사	1	
F-41	43-010G-3400		Knee Support Rubber Tension Spring	무릎받침 고무 텐션 스프링	1	
F-42	91-002S-3400		Screw For F-25	목나사	4	
F-43	20-004C-380B	B	Tape Guide	테이프 안내	1	
F-44	SC-0176-1230	B	Screw (11/64" n=40)	하축카라 고정나사 (11/64" n=40)	1	
F-45	20-001A-380B	B	Tape Stand Ass'y	테이프 꽃이 (조)	1Set	
F-46	91-001S-3400	B	Screw For F-42	목나사	3	
F-47	91-008C-1230		Oiler	오일캔	1	
F-48	60-201A-3800		Belt Cover Ass'y	벨트커버 (조)	1Set	

NOTE:
 A=KM-380A
 B=KM-380B

수정 리스트 Changed Parts List

No.	Ref. No.	Parts No.	Name of Parts	Contents	Date	Old Parts No.	Remarks
1	A-62	01-005A-380A	Bed Hinge Ass'y	Substitution	99. 12	01-005A-3800	99. 4/4
2	F-1	91-006C-2700	Head Cover	Substitution	00. 3	91-013C-1230	00. 1/4
3	C-22	SN-0105-4000	Nut (15/64" n = 28)	Substitution	00. 10	SN-0107-4000	
4	C-27	SC-0174-4122	Screw (11/64" n = 40) Arm	Substitution	00. 10	SC-0174-4124	
5	A-9	SC-0363-3710	Thread Guide (B)	Substitution	01. 11	SC-0365-4118	
6	A-8	SC-0120-1230	Screw (9/64" n = 40)	Substitution	01. 11	SC-0120-2118	
7	A-10	SC-0120-1230	Screw (9/64" n = 40)	Substitution	01. 11	SC-0120-2118	
8	A-12	SC-0120-1230	Screw (9/64" n = 40)	Substitution	01. 11	SC-0120-2118	
9	A-14	SC-0120-1230	Screw (9/64" n = 40)	Substitution	01. 11	SC-0120-2118	
10	A-16	SC-0175-1230	Screw (11/64" n = 40)	Substitution	01. 11	SC-0175-4522	
11	A-17	SC-0352-7400	Screw (3/16" n = 28)	Substitution	01. 11	SC-0352-4515	
12	A-19	SC-0502-2302	Screw (9/64" n = 40)	Substitution	01. 11	SC-0502-4125	
13	A-20	01-127A-1230	Three Hole Thread Guide Eyelet	Substitution	01. 11	01-015A-1230	
14	A-20-1	01-015A-1230	Three Hole Thread Guide Eyelet	Substitution	01. 11		
15	A-23	SC-0179-3710	Screw (11/64" n = 40)	Substitution	01. 11	SC-0179-4125	
16	A-28	SC-0175-1230	Screw (11/64" n = 40)	Substitution	01. 11	SC-0175-4522	
17	A-30	SC-0498-3710	Screw (11/64" n = 40)	Substitution	01. 11	SC-0498-4122	
18	A-34	SC-0365-3710	Screw (3/16" n = 32)	Substitution	01. 11	SC-0365-4118	
19	A-36	SC-0365-3710	Screw (9/64" n = 40)	Use Only For B-Type	01. 11	SC-0365-4118	
20	A-41	SC-0505-3710	Screw (9/64" n = 40)	Additional Parts	01. 11	SC-0505-4120	
21	A-43	SC-0309-3800	Screw (9/64" n = 40)	Substitution	01. 11	SC-0309-4120	
22	A-46	SC-0189-380A	Screw (11/64" n = 40)	Substitution	01. 11	SC-0189-4120	
23	A-51	SC-0145-3800	Screw (9/64" n = 40)	Substitution	01. 11	SC-0145-4114	
24	A-53	SC-0501-2302	Screw (11/64" n = 40)	Substitution	01. 11	SC-0501-4120	
25	A-63	SC-0325-3800	Screw (M8×1.25)	Substitution	01. 11	SC-0325-4113	
26	B-1	02-101A-3800	Main Shaft	Substitution	01. 11	02-001A-3800	
27	B-2	02-104A-3800	Front Bushing For B-1	Substitution	01. 11	02-004A-3800	
28	B-4	02-105A-3800	Center Bushing For B-1	Substitution	01. 11	02-005A-3800	
29	B-6	SC-0507-1230	Screw (15/64" n = 28)	Substitution	01. 11	SC-0507-4515	
30	B-7	02-121A-1230	Main Shaft Collar	Substitution	01. 11	02-022A-1230	
31	B-11	02-106A-3800	Rear Bushing For B-1	Substitution	01. 11	02-006A-3800	
32	B-14	SC-0150-2500	Screw (15/64" n = 28)	Substitution	01. 11	SC-0150-4122	
33	B-15	SC-0188-1230	Screw (5/16" n = 24)	Substitution	01. 11	SC-0188-4124	
34	B-16	02-102A-3800	Counterweight	Substitution	01. 11	02-002A-3800	
35	B-17	SC-0535-3710	Screw (9/32" n = 28)	Substitution	01. 11	SC-0535-4325	
36	B-18	SC-0148-2302	Screw (9/32" n = 28)	Substitution	01. 11	SC-0148-4515	
37	B-20	SC-0504-1230	Screw (1/4" n = 40)	Substitution	01. 11	SC-0504-4515	
38	B-24	02-103A-7400	Holder For B-25	Substitution	01. 11	02-003A-7400	
39	B-25	08-101A-3800	Thread Take-Up Lever	Use Only for B-Type	01. 11	08-001A-3800	
40	B-28	SC-0507-1230	Screw (15/64" n = 28)	Additional Parts	01. 11	SC-0507-4515	

NOTE)

수정 리스트 Changed Parts List

No.	Ref. No.	Parts No.	Name of Parts	Contents	Date	Old Parts No.	Remarks
41	B-29	04-103A-3800	Needle Bar Holder	Substitution	99. 12	04-003A-3800	
42	B-31	SC-0158-3710	Screw (9/64" n = 40)	Substitution	00. 3	SC-0158-4122	
43	B-39	SC-0507-1230	Screw (15/64" n = 28)	Substitution	00. 10	SC-0507-4515	
44	B-41	SC-0180-3800	Screw (11/64" n = 40)	Substitution	00. 10	SC-0180-4111	
45	B-44	SN-0115-7400	Nut (3/16" n = 32)	Substitution	01. 11	SN-0115-4000	
46	B-47	15-124A-3800	Needle Bar Frame Driving Shaft	Substitution	01. 11	15-024A-3800	
47	B-48	15-123A-3800	Driving Shaft Crank (Rear)	Substitution	01. 11	15-023A-3800	
48	B-49	SC-0500-7400	Screw (15/64" n = 28)	Substitution	01. 11	SC-0500-4125	
49	B-52	15-122A-3800	Driving Shaft Connecting Rod	Substitution	01. 11	15-022A-3800	
50	B-55	SC-0528-1230	Screw (9/64" n = 40)	Substitution	01. 11	SC-0528-4125	
51	B-59	03-102A-3800	Upper Bushing For B-56	Substitution	01. 11	03-002A-3800	
52	B-60	SC-0507-1230	Screw (15/64" n = 28)	Substitution	01. 11	SC-0507-4515	
53	B-61	03-103A-3800	Lower Bushing For B-56	Substitution	01. 11	03-003A-3800	
54	B-62	SC-0507-1230	Screw (15/64" n = 28)	Substitution	01. 11	SC-0507-4515	
55	B-66	07-101A-380B	Lower Shaft	Substitution	01. 11	07-001A-380B	
56	B-68	SC-0111-380B	Screw (9/64" n = 40)	Substitution	01. 11	SC-0111-4515	
57	B-73	SC-0507-1230	Oil Felt For B-71	Substitution	01. 11	SC-0507-4515	
58	B-81	SC-0335-3800	Screw (3/16" n = 32)	Substitution	01. 11	SC-0335-4122	
59	B-83	07-105A-2700	Bobbin	Substitution	01. 11	07-008A-1230	
60	C-1	05-302A-3800	Presser Bar	Substitution	01. 11	05-202A-3800	
61	C-4	SC-0315-2302	Screw (9/64" n = 40)	Substitution	01. 11	SC-0315-4122	
62	C-5	SC-0367-3400	Screw (9/64" n = 20)	Substitution	01. 11	SC-0367-4322	
63	C-6	SN-0100-3400	Nut (9/16" n = 20)	Substitution	01. 11	SN-0100-4000	
64	C-8	05-102A-3800	Presser Bar Bracket	Substitution	01. 11	05-002A-3800	
65	C-13	05-109A-3800	Bushing For C-1	Substitution	01. 11	05-009A-3800	
66	C-14	SC-0509-1230	Screw (15/64" n = 28)	Substitution	01. 11	SC-0509-4515	
67	C-15	15-115A-3800	Upper Feed Thread Bar	Substitution	01. 11	15-015A-3800	
68	C-18	SC-0128-7400	Screw (11/64" n = 40)	Substitution	01. 11	SC-0128-4118	
69	C-21	SC-0343-3800	Screw (15/64" n = 28)	Substitution	01. 11	SC-0343-4122	
70	C-22	SN-0105-3400	Nut (15/64" n = 28)	Substitution	01. 11	SN-0105-4000	
71	C-23	15-114A-3800	Driving Link For C-16	Substitution	01. 11	15-014A-3800	
72	C-27	SC-0174-1230	Screw (11/64" n = 40)	Substitution	01. 11	SC-0174-4122	
73	C-31	SC-0307-1230	Screw (3/16" n = 32)	Substitution	01. 11	SC-0307-4122	
74	C-34	15-112A-3800	Connecting Link For C-16	Substitution	01. 11	15-012A-3800	
75	C-38	SN-0101-1600	Nut (11/64" n = 40)	Substitution	01. 11	SN-0101-4000	
76	C-39	15-110A-3800	Upper Feed Connecting Link	Substitution	01. 11	15-010A-3800	
77	C-41	SN-0116-3400	Nut (1/4" n = 40)	Substitution	01. 11	SN-0116-4000	
78	C-42	15-108A-3800	Upper Feed Driving Shaft	Substitution	01. 11	15-008A-3800	
79	C-43	15-109A-3800	Bushing For C-42	Substitution	01. 11	15-009A-3800	
80	C-44	15-103A-3800	Upper Feed Lifting Adjusting Crank	Substitution	01. 11	15-003A-3800	

NOTE)

수정 리스트 Changed Parts List

No.	Ref. No.	Parts No.	Name of Parts	Contents	Date	Old Parts No.	Remarks
81	C-45	SC-0334-3800	Screw (1/4" n=24)	Substitution	99. 12	SC-0334-4111	
82	C-47	15-106A-3800	Bushing For B-46	Substitution	00. 3	15-006A-3800	
83	C-49	SN-0115-7400	Nut (3/16" n=32)	Substitution	00. 10	SN-0115-4000	
84	C-50	15-102A-3800	Rod For C-53	Substitution	00. 10	15-002A-3800	
85	C-53	15-101A-3800	Upper Feed Lifting Eccentric Cam	Substitution	01. 11	15-001A-3800	
86	C-62	SN-0119-1230	Nut (3/16" n=28)	Substitution	01. 11	SN-0119-4000	
87	C-64	SC-0128-7400	Screw (11/64" n=40)	Substitution	01. 11	SC-0128-4118	
88	D-1	06-116A-380A	Feed Locker Shaft	Substitution	01. 11	06-016A-380A	
89	D-2	06-116A-380B	Feed Locker Shaft	Substitution	01. 11	06-016A-380B	
90	D-4	SC-0104-5607	Screw (11/64" n=40)	Substitution	01. 11	SC-0104-4517	
91	D-5	SC-0200-3800	Screw (11/64" n=40)	Substitution	01. 11	SC-0200-4123	
92	D-7	SC-0201-1230	Screw (5/16" n=24)	Substitution	01. 11	SC-0201-4517	
93	D-20	SC-0138-3800	Screw (1/8" n=44)	Substitution	01. 11	SC-0138-4118	
94	D-23	SC-0179-3710	Screw (11/64" n=40)	Substitution	01. 11	SC-0179-4125	
95	D-28	SC-0198-3800	Screw (9/64" n=40)	Substitution	01. 11	SC-0198-4122	
96	D-30	SC-0138-3800	Screw (1/8" n=44)	Substitution	01. 11	SC-0138-4118	
97	D-32	15-121A-3800	Needle Bar Frame Driving Crank	Substitution	01. 11	15-021A-3800	
98	D-33	SC-0122-1230	Screw (15/64" n=28)	Substitution	01. 11	SC-0122-4522	
99	D-34	SC-0330-7400	Screw (15/64" n=28)	Substitution	01. 11	SC-0330-4422	
100	D-37	06-119A-3800	Crank For D-1	Substitution	01. 11	06-019A-3800	
101	D-38	SC-0122-1230	Screw (15/64" n=28)	Substitution	01. 11	SC-0122-4522	
102	D-39	SC-0330-7400	Screw (15/64" n=28)	Substitution	01. 11	SC-0330-4422	
103	D-43	06-102A-3400	Connecting Ring For D-42	Substitution	01. 11	06-002A-3400	
104	D-46	06-101A-3800	Feed Cam	Substitution	01. 11	06-001A-3800	
105	D-47	SC-0509-1230	Screw (15/64" n=28)	Substitution	01. 11	SC-0509-4515	
106	D-48	06-107A-3800	Feed Link	Substitution	01. 11	06-007A-3800	
107	D-50	SN-0107-1230	Nut (9/32" n=28)	Substitution	01. 11	SN-0107-4000	
108	D-52	SN-0107-1230	Nut (9/32" n=28)	Substitution	01. 11	SN-0107-4000	
109	D-56	SC-0500-7400	Screw (15/64" n=28)	Substitution	01. 11	SC-0500-4125	
110	D-58	SC-0500-7400	Screw (15/64" n=28)	Substitution	01. 11	SC-0500-4125	
111	D-64	SC-0193-1230	Screw (3/16" n=28)	Substitution	01. 11	SC-0193-4122	
112	D-67	06-111A-3800	Crank For D-58	Substitution	01. 11	06-011A-3800	
113	D-68	SC-0497-1230	Screw (3/16" n=28)	Substitution	01. 11	SC-0497-4122	
114	D-69	SC-0500-7400	Screw (15/64" n=28)	Substitution	01. 11	SC-0500-4125	
115	D-70	06-112A-3800	Shaft For D-72	Substitution	01. 11	06-012A-3800	
116	D-73	SC-0186-1230	Screw (3/16" n=32)	Substitution	01. 11	SC-0186-4118	
117	D-74	SC-0185-1230	Screw (3/16" n=32)	Substitution	01. 11	SC-0185-4124	
118	D-77	SN-0101-1600	Nut (11/64" n=40)	Substitution	01. 11	SN-0101-4000	
119	D-79	SC-0497-1230	Screw (3/16" n=28)	Substitution	01. 11	SC-0497-4122	
120	E-5	SC-0179-3710	Screw (11/64" n=40)	Substitution	01. 11	SC-0179-4125	

NOTE)

수정 리스트 Changed Parts List

No.	Ref. No.	Parts No.	Name of Parts	Contents	Date	Old Parts No.	Remarks
121	E-11	SC-0531-2302	Screw (9/64" n = 40)	Substitution	01. 11	SC-0531-4125	
122	E-18	SC-0365-3710	Screw (9/64" n = 40)	Substitution	01. 11	SC-0365-4118	
123	E-20	SC-0531-2302	Screw (9/64" n = 40)	Substitution	01. 11	SC-0531-4125	
124	E-26	SC-0531-2302	Screw (9/64" n = 40)	Substitution	01. 11	SC-0531-4125	
125	E-29	SC-0531-2302	Screw (9/64" n = 40)	Substitution	01. 11	SC-0531-4125	
126	F-10	07-105A-2700	Bobbin	Substitution	01. 11	07-008A-1230	
127	F-15	SC-0143-3800	Screw (M6×1.0)	Substitution	01. 11	SC-0143-4114	
128	F-17	SN-0102-3800	Nut (M6×1.0)	Substitution	01. 11	SN-0102-4000	
129	F-19	SC-0120-1230	Screw (9/64" n = 40)	Substitution	01. 11	SC-0120-2118	
130	F-20	SC-0543-2302	Screw (11/64" n = 40)	Substitution	01. 11	SC-0543-4525	
131	F-24	SC-0500-7400	Screw (15/64" n = 28)	Substitution	01. 11	SC-0500-4125	
132	F-30	SC-0181-1230	Screw (5/16" n = 18)	Substitution	01. 11	SC-0181-4116	
133	F-33	SC-0181-1230	Screw (5/16" n = 18)	Substitution	01. 11	SC-0181-4116	
134	F-35	SC-0181-1230	Screw (5/16" n = 18)	Substitution	01. 11	SC-0181-4116	
135	F-44	SC-0176-1230	Screw (11/64" n = 40)	Substitution	01. 11	SC-0176-4118	
136	A-31	01-116A-2350	Upper Thread Guide Pin	Substitution	02. 06	01-016A-2350	
137	A-44	SC-0309-3800	Screw	Substitution	02. 06	SC-0145-4114	
138	C-44	15-203A-3800	Upper Feed Lifting Adjusting Crank	Substitution	02. 06	15-103A-3800	
139	C-46	15-007A-5607	Upper Feed Lifting Adjusting Shaft	Substitution	02. 06	15-005A-3800	
140	C-47	15-206A-3800	Bushing For B-46	Substitution	02. 06	15-106A-3800	
141	C-48	11-009A-5607	Washer For C-46	Substitution	02. 06	15007W-3800	
142	C-49	SN-0116-3400	Nut	Substitution	02. 06	SN-0115-7400	
143	C-50	15-202A-3800	Rod For C-53	Substitution	02. 06	15-102A-3800	
144	C-68	15-026W-3400	Washer	Additional Parts	02. 06		
145	D-42	06-102A-3800	Y-Rod	Substitution	02. 06	06-002A-3800	
146	D-78	06-139C-1600	Suspension Bracket	Substitution	02. 06	06-039C-1600	
147	E-17	44-110A-3800	Wick Holder For E-16	Substitution	02. 06	44-010A-3400	
148	E-25	44-124C-3400	Oil Wick Holder For E-24	Substitution	02. 06	44-024C-3400	
149	F-18	60-101A-3800	Belt Cover Ass'y	Substitution	02. 06	60-001A-3800	2/4
150	F-47	91-008C-1230	Oiler	Substitution	02. 09	91-108C-1230	3/4
151	B-76	06-140A-3800	Holder(A) For B-77	Substitution	02. 10	06-040A-3800	02. 4/4
152	B-78	06-141A-3800	Holder(B) For B-77	Substitution	02. 10	06-041A-3800	02. 4/4
153	C-24	15-117A-3800	Guide Block For C-15	Substitution	02. 11	15-017A-3800	02. 4/4
154	B-32	04-101A-3800	Needle Bar	Substitution	02. 11	04-001A-3800	02. 4/4
155	B-42	15-128A-3800	Block For B-36	Substitution	02. 11	15-028A-3800	02. 4/4
156	F-48	60-201A-3800	Belt Cover Ass'y	Additional Parts	03. 03		03. 1/4
157	B-23	04-008A-5607	Crank For B-32	Substitution	03. 03	04-008A-390A	03. 1/4
158	C-25	15-123A-5607	Guide Plate For C-15	Substitution	03. 02	15-023A-5607	03. 1/4
159							
160							

NOTE)



По вопросам приобретения или с целью консультации
вы можете обращаться по телефону: (495) 989-22-97
или по e-mail: info@krung.ru

Также предлагаем вам посетить
наш информационный сайт
www.krung.ru