

# CLINTON SERVICE GUIDE MODEL 115VS-FOTA FOR BROTHER B925

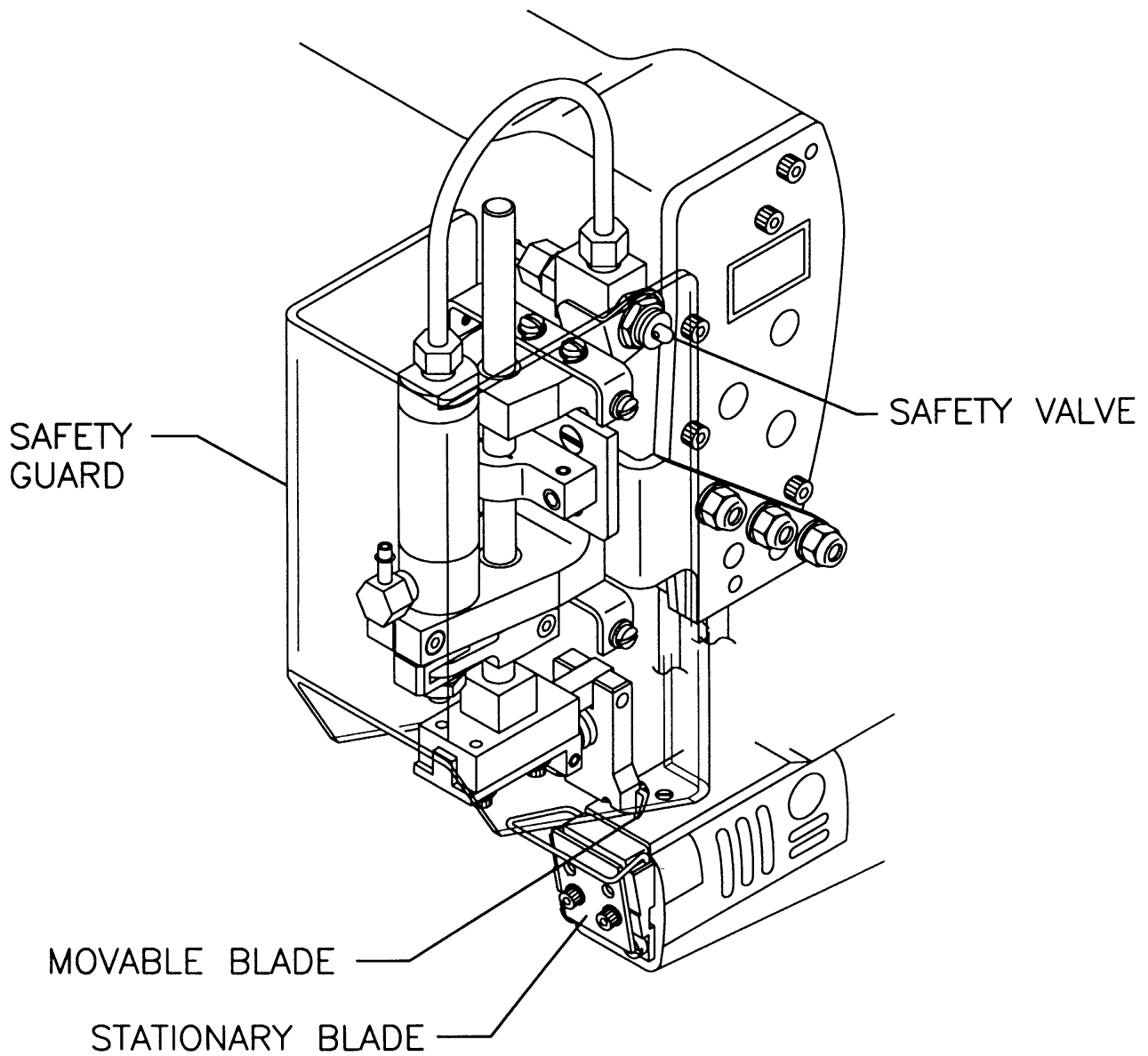

CLINTON INDUSTRIES, INC.  
700 Washington Avenue  
Carlstadt, N.J. 07072  
Phone: 201-935-4242  
FAX: 201-935-3615  
Web Site: <http://www.clintonind.com>  
Email: [general@clintonind.com](mailto:general@clintonind.com)

## DRILLING & INSTALLATION INSTRUCTIONS

### CUTTER ASSEMBLY

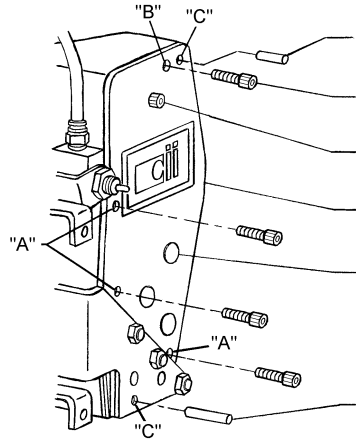

- 33-3712-08  
DOWEL PIN
- 33-3108-08 (4)  
SCREW
- 33-3108-04  
SCREW
- 02-2645-01  
FACE PLATE
- 30-1509-01  
PLUG
- 33-3712-16  
DOWEL PIN

### DRILL JIG

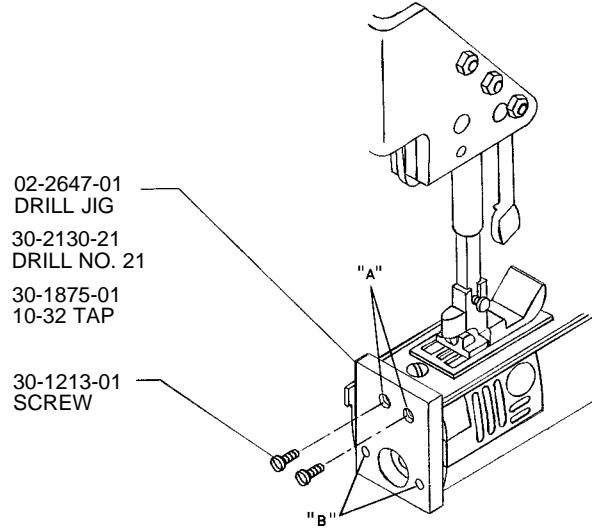

- 02-2647-01  
DRILL JIG
- 30-2130-21  
DRILL NO. 21
- 30-1875-01  
10-32 TAP
- 30-1213-01  
SCREW

**NOTES:**

1. REMOVE EXISTING FACE PLATE AND RETAP (3) HOLES MARKED "A" WITH DRILL NO.29 (30-2130-29) AND TAP 8-32 (30-1266-01) SUPPLIED.
2. MOUNT VERTICAL SHEAR CUTTER WITH (3) SCREWS 33-3108-08.
3. DRILL HOLE, MARKED "B" WITH DRILL NO.29 AND TAP 8-32, 5/16 DEEP.
4. USING HOLES MARKED "C" AS A GUIDE, DRILL (2) HOLES 3/16" DIAMETER BY 3/16" DEEP. 3/16" DRILL (30-2376-12) SUPPLIED.
5. INSERT DOWEL PINS (1) 33-3712-08 UPPER SIDE, AND (1) 33-3712-16 LOWER SIDE.

**NOTES:**

1. FASTEN DRILL JIG 02-2647-01 TO MACHINE USING SCREWS 30-1213-01 SUPPLIED AT POINTS MARKED "A".
2. USING DRILL NO. 21,(30-2130-21) DRILL THE CASTING AT POINTS MARKED "B " 3/8" DEEP. REMOVE THE DRILL JIG AND TAP HOLES AT POINTS MARKED "B" USING THE 10-32 (30-1875-01) TAP SUPPLIED.

### MOVABLE BLADE

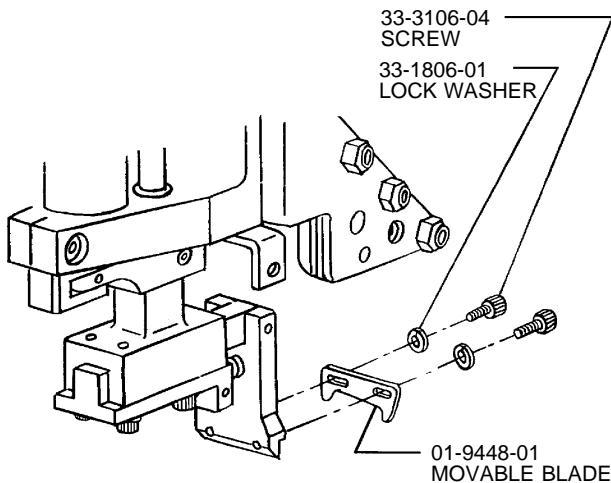

- 33-3106-04  
SCREW
- 33-1806-01  
LOCK WASHER
- 01-9448-01  
MOVABLE BLADE

**NOTES:**

1. ASSEMBLE MOVABLE BLADE 01-9448-01 WITH SCREWS (2) 33-3106-04 AND LOCK WASHERS (2) 33-1806-01.
2. DO NOT TIGHTEN MOVABLE BLADE SCREWS AT THIS TIME. REFER TO ALIGNMENT ADJUSTMENT.

### STATIONARY BLADE

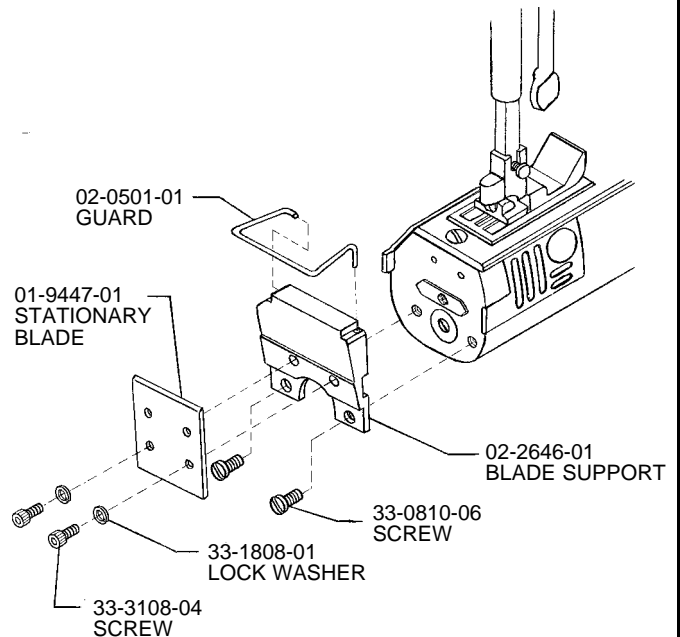

- 02-0501-01  
GUARD
- 01-9447-01  
STATIONARY BLADE
- 02-2646-01  
BLADE SUPPORT
- 33-0810-06  
SCREW
- 33-1808-01  
LOCK WASHER
- 33-3108-04  
SCREW

**NOTE:**

ASSEMBLE STATIONARY BLADE AS SHOWN.

**ADJUSTMENTS**

**WARNING!! TO PREVENT SERIOUS INJURY, DISCONNECT AIR SUPPLY BEFORE MAKING ANY ADJUSTMENTS.**

**RADIAL**

INS-2298

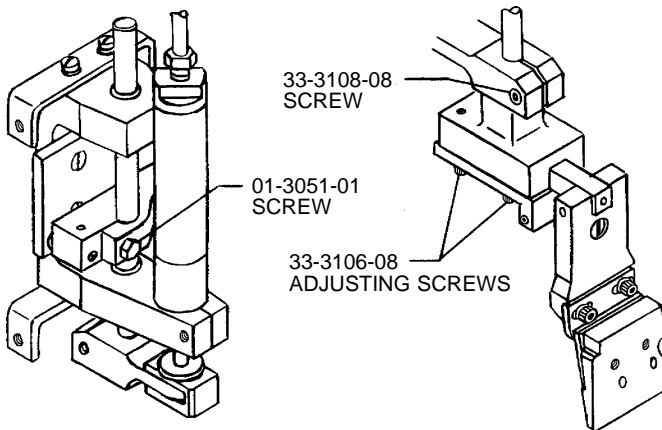

**ALIGNMENT**

INS-2299

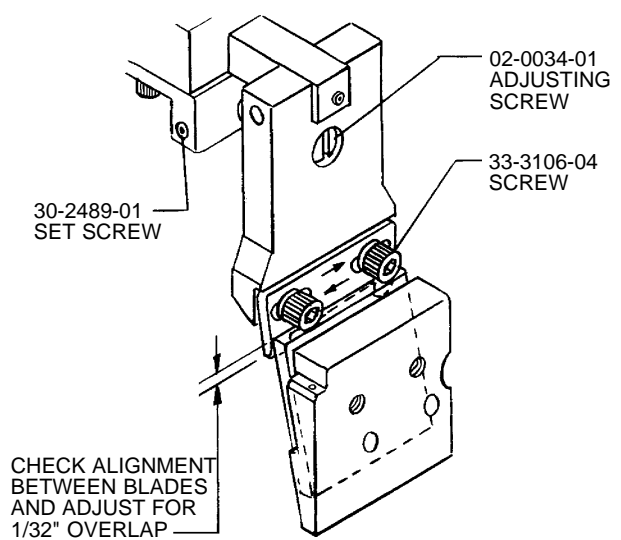

**NOTES:**

1. LOOSEN SCREW 01-3051-01 AND 33-3108-08 AND ROTATE ASSEMBLY FOR PROPER ENGAGEMENT.
2. LOOSEN SCREWS 33-3106-08 AND ADJUST MOVABLE BLADE AGAINST STATIONARY BLADE AND LOCK IN PLACE.

**NOTE:**

LOOSEN SET SCREW 30-2489-01 AND ADJUST SCREW 02-0034-01 COUNTER-CLOCKWISE FOR MORE CUTTING EDGE ENGAGEMENT.

**AIR CIRCUIT DIAGRAM**  
MODEL 115VS KS  
MODEL 115VS F.O.R.G.-KS

INS-2664

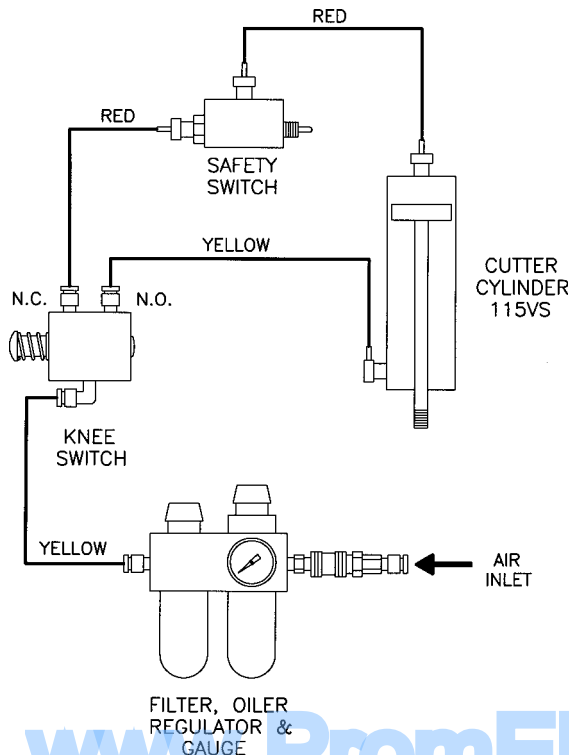

**4 WAY AIR VALVE, KNEE OPERATED**  
80-0185-01

INS-619-1A

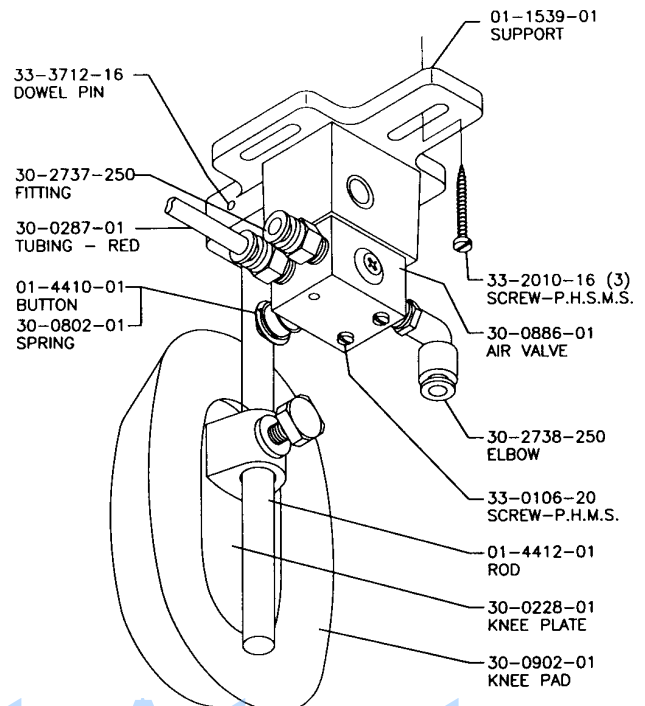

PARTS LIST  
 MODEL 115VS-FOTA  
 BROTHER B925  
 80-0486-03

- 30-1132-01 AIR VALVE
- 30-2102-03 RED TUBING
- 02-1542-01 BRACKET
- 33-0106-05 SCREW
- 33-1806-01 LOCK WASHER
- 30-1106-01 FITTING
- 30-1988-01 AIR CYLINDER
- 30-1107-01 ELBOW
- 02-1543-01 BRACKET
- 10-1315-01 SUPPORT
- 02-1527-01 WEAR PLATE
- 33-0308-06 SCREW
- 30-0672-01 BEARING
- 30-2489-01 SET SCREW
- 02-1591-01 BUSHING MOUNT
- 33-2816-04 SET SCREW
- 01-3051-01 SCREW
- 30-2549-01 WASHER
- 01-8811-02 ADAPTOR
- 33-1616-02 JAM NUT
- 33-0106-04 SCREW
- 02-1581-01 GUARD
- 01-8798-01 WARNING LABEL
- 33-1706-02 FLAT WASHER
- 33-1806-01 LOCK WASHER
- 33-3106-08 SCREW
- 02-0501-01 GUARD
- 02-2646-01 SUPPORT
- 33-0810-06 SCREW
- 01-9447-01 BLADE
- 33-1808-01 LOCK WASHER
- 33-3108-04 SCREW

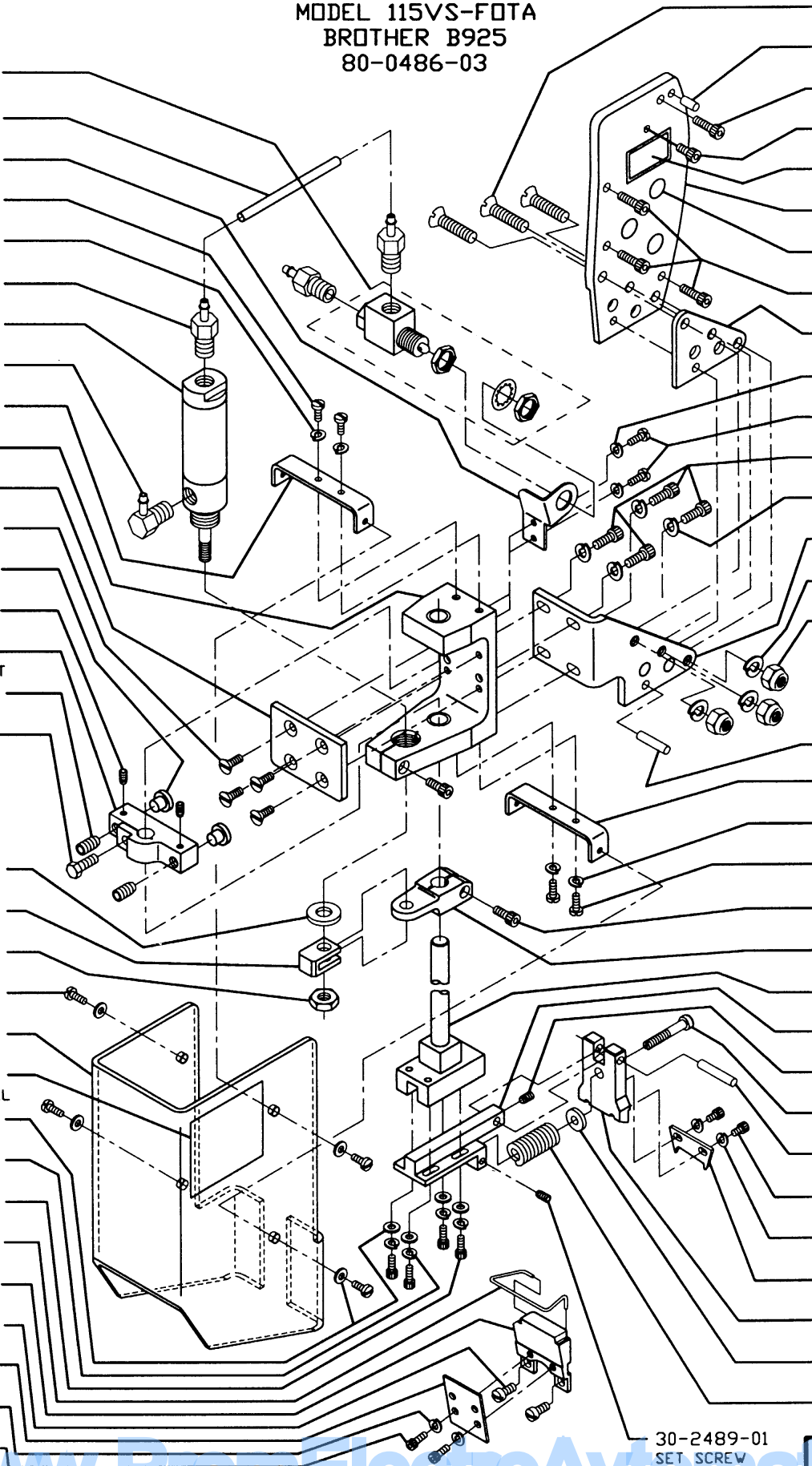

- 33-3410-16 SCREW
- 33-3712-08 DOWEL PIN
- 33-3108-08 SCREW
- 33-3108-04 SCREW
- 01-5325-01 LOGO
- 02-2645-01 FACE PLATE
- 30-1509-01 (3) PLUG
- 33-3108-08 SCREW
- 02-0502-01 SPACER
- 33-1806-01 LOCK WASHER
- 33-0106-05 SCREW
- 33-3210-07 SCREW
- 33-1810-01 LOCK WASHER
- 02-1539-01 BRACKET
- 33-1810-01 LOCK WASHER
- 30-0618-01 LOCK NUT
- 33-3712-16 DOWEL PIN
- 02-1543-01 BRACKET
- 33-1806-01 LOCK WASHER
- 33-0106-05 SCREW
- 33-3108-08 SCREW
- 02-1556-01 CLAMP
- 10-1301-01 BLOCK & SHAFT
- 02-0032-01 SUPPORT
- 30-2574-01 SET SCREW
- 02-0034-01 ADJUSTING SCREW
- 33-3712-16 DOWEL PIN
- 33-3106-04 SCREW
- 33-1806-01 LOCK WASHER
- 01-9448-01 MOVABLE BLADE
- 02-0033-01 BLADE HOLDER
- 01-1892-08 SPACER
- 30-2590-01 SPRING

30-2489-01 SET SCREW

INS-2336B