



**AC SERVOMOTOR  
AC-SERVOMOTOR  
SERVOMOTEUR AC  
SERVOMOTOR DE AC**

**MD-601 (Single-Phase Type)  
MD-611 (Three-Phase Type)**



**PARTS BOOK  
TEILEKATALOG  
LIVRE DES PIECES  
LIBRO DE REFERENCIA DE PIEZAS .**



## Notes for using this parts book

1. If the symbol  is found in the "Parts No." column of the "Assembly No." column, refer to the different parts list on page 18.
2. The symbol  in the "Parts No." column indicates that the parts is not available for supply. If, however, there is a number in the "Assembly No." column, the parts can be ordered as an assembly. Please, therefore, order by using the assembly number.
3. This book was prepared based on information available in March 2000.
4. Parts are subject to changes in design without prior notice.

## Hinweise zur Verwendung dieser Teileliste

1. Dieses Zeichen  in der Spalte "Parts No. (Teilnummer)" oder "Assembly No. (Gerätesatznummer)" verweist auf die Gesonderte Stückliste auf Seite 18.
2. Dieses Zeichen  in der Spalte "Teilnummer" bedeutet, daß dieser Teil nicht lieferbar ist. Wenn jedoch in der Spalte "Gerätesatznummer" eine Nummer steht, kann dieser Teil als ein Geräteteilsatz bestellt werden. Bestellen Sie daher bitte mit dieser Gerätesatznummer.
3. Dieses Buch basiert auf den Informationen vom März 2000.
4. Modelländerungen sind vorbehalten.



## CONTENTS

A . Motor mechanism .....	1
B . Safety cover .....	3
C . Control box (1) .....	5
D . Control box (2) .....	7
E . Operation panel, switch box mechanism (1) .....	9
F . Operation panel, switch box mechanism (2) .....	11
G . Material edge sensor related (option) (1) .....	13
H . Material edge sensor related (option) (2) .....	14
I . Pedal for standing operation.....	15
J . Synchronizer .....	17
DIFFERENT PARTS LIST .....	18
INDEX .....	21

## INHALTSVERZEICHNIS

A . Motors .....	1
B . Sicherheitsdeckung .....	3
C . Schaltkasten (1) .....	5
D . Schaltkasten (2) .....	7
E . Schaltkasten (1) .....	9
F . Schaltkasten (2) .....	11
G . Für Materialkantensensor (Sonderausstattung) (1) .....	13
H . Für Materialkantensensor (Sonderausstattung) (2) .....	14
I . Fusstritt für stehenden Arbeitsplatz .....	15
J . Synchronisator .....	17
ZUBEHÖRLISTE .....	18
VERZEICHNIS .....	21



## Notes sur l'utilisation de ce manuel de pièces détachées

1. Si le symbole  se trouve dans la colonne "Parts No. (N° de pièce)" ou dans la colonne "Assembly No. (N° jeu de pièces)", veuillez vous référer à la liste de pièces annexe page 18.
2. Le symbole  dans la colonne "N° de pièce" signifie que la pièce ne peut être fournie. Si, dans la colonne "N° jeu de pièces", il y a un numéro de nomenclature, la pièce peut être commandée comme faisant partie d'un jeu de pièces. Donc, pour toute commande, veuillez spécifier le n° du jeu de pièces.
3. Ce manuel a été fait d'après les renseignements valables au mois de mars 2000.
4. Les pièces peuvent être sujettes à des modifications sans préavis.

## TABLE DES MATIERES

A . Mécanisme du moteur .....	1
B . Couvercle de sécurité .....	3
C . Mécanisme du boîtier de contrôle (1) .....	5
D . Mécanisme du boîtier de contrôle (2) .....	7
E . Boîtier d'interrupteurs (1) .....	9
F . Boîtier d'interrupteurs (2) .....	11
G . Capteur de bord de tissu relatif (en option) (1).....	13
H . Capteur de bord de tissu relatif (en option) (2).....	14
I . Pédale pour opération en station debo .....	15
J . Synchronisateur .....	17
LISTE DES PIECES ACCESSOIRES .....	18
INDEX .....	21

## Notas para usar este Libro de Piezas

1. De haber un símbolo  junto al "Parts No. (Número de Pieza)" o en la columna del "Assembly No. (Número de juego)", habrá que mirar la lista de piezas separada de la página 18.
2. El símbolo , que se encuentra en la columna del "Número de Pieza", quiere decir que no se dispone de dicha pieza sola. Cuando, empero, hay un número en la columna del "Número de Juego", se podrá ordenar la pieza con todo el juego. Por lo tanto, será mejor hacer el pedido recurriendo al número del juego respectivo.
3. Este libro ha sido compilado basándose en los datos de que se disponía en marzo 2000.
4. Las piezas quedan sujetas a cambios de diseño sin aviso previo.

## INDICE

A . Mecanismo del motors .....	1
B . Cubierta de seguridad .....	3
C . Mecanismo de la caja de controles (1) .....	5
D . Mecanismo de la caja de controles (2) .....	7
E . Caja de interruptores (1).....	9
F . Caja de interruptores (2).....	11
G . Piezas relacionadas al detector de borde de tejidos (opcional) (1) .....	13
H . Piezas relacionadas al detector de borde de tejidos (opcional) (2) .....	14
I . Pedal para operar de pie .....	15
J . Sincronizador .....	17
LISTA DE PIEZAS ACCESORIAS .....	18
INDICE.....	21

A. Motor mechanism / Motors /  
Mécanisme du moteur / Mecanismo del motors

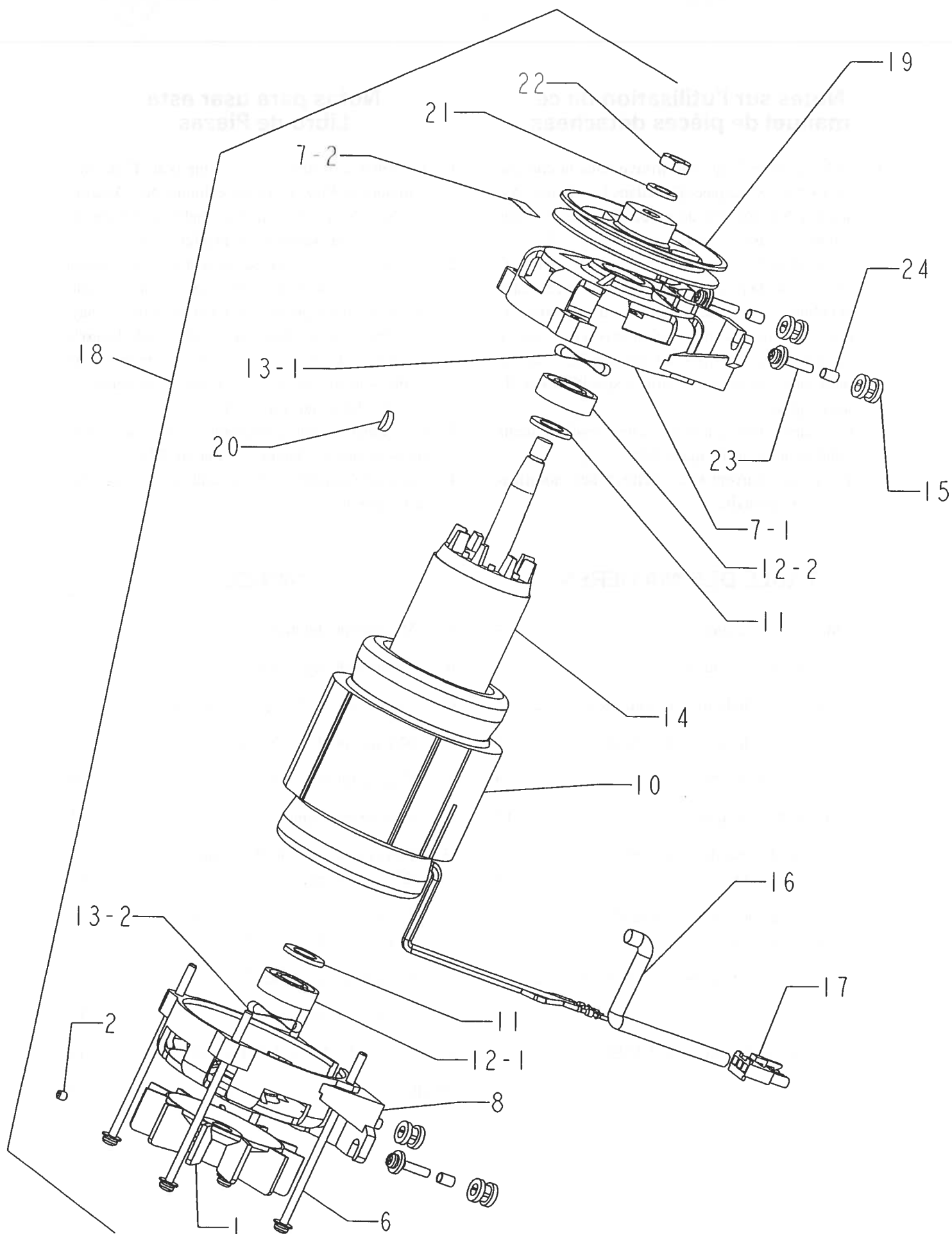

REF. NO.	CODE	Q' TY	NAME OF PARTS	REF. NO.	CODE	Q' TY	NAME OF PARTS
1	J02525-001	1	MOTOR FAN	14	*	1	ROTOR
2	014500-632	1	SCREW 5X6	15	J02991-001	4	RUBBER WASHER, INV
6	*	4	SCREW 5XL	16	J02563-001	1	TUBE 8X0.25X200
7-1	J03333-001	1	MOTOR BRACKET	17	J02560-001	1	3P PLUG 3191-03R1BL
7-2	---	1	NAME PLATE	18	*	1	INV MOTOR ASSY
8	*	1	MOTOR BRACKET	19	*	1	TAPER PULLEY
10	*	1	STATOR ASSY	20	216205-000	1	KEY 4X13#2
11	J02997-001	2	WASHER 2.6X15X26ST	21	028100-246	1	SPRING WASHER 2-10
12-1	076202-801	1	BEARING 6202ZZ #2	22	J02493-001	1	NUT 3-10X1.0
12-2	*	1	BEARING 6202	23	J02992-001	4	SCREW 5X25DC
13-1	*	1	WAVE WASHER	24	J02989-001	4	COLLAR 5.1X0.6X9
13-2	*	1	WAVE WASHER				

DIFFERENT PARTS LIST ( for B737 etc , LOCK )

REF. NO.	NAME OF PARTS	MD-601 , MD-611 110V~240V		MD-611 380V~415V	
		B737 etc	LOCK	B737 etc	LOCK
		6	SCREW 5X110DB	J02537-001	
8	MOTOR BRACKET	J03314-001			
10	STATOR ASSY	J80654-001	J80654-002	J80656-001	J80656-002
12-2	BEARING 6202ZZ #2	076202-801			
13-1	WAVE WASHER	203684-001			
13-2	WAVE WASHER	---			
14	ROTOR	J02518-001			
18	INV MOTOR ASSY	J80643-001	J80643-002	J80652-001	J80652-002
	90	J02278-001	---	J02278-001	---
19	TAPER PULLEY 105	J02281-001			

DIFFERENT PARTS LIST ( for B891 , B256 etc )

REF. NO.	NAME OF PARTS	MD-601 , MD-611 110V~240V		MD-611 380V~415V	
		B891	B256 etc	B891	B256 etc
		6	SCREW 5X130DB	J02538-001	
8	MOTOR BRACKET	J03314-001			
10	STATOR ASSY	J80655-001	J80655-002	J80657-001	J80657-002
12-2	BEARING 6202VV	J00715-001			
13-1	WAVE WASHER	---			
13-2	WAVE WASHER	203684-001			
14	ROTOR	J02521-001			
18	INV MOTOR ASSY	J80644-001	J80644-002	J80653-001	J80653-002
	80	J02276-001	---	J02276-001	---
19	TAPER PULLEY 105	---	J02281-001	---	J02281-001

DIFFERENT PARTS LIST ( for B883 , C51 , P73 , P81 , B776 , B722/4 , B877/8 )

REF. NO.	NAME OF PARTS	MD-601 , MD-611 110V~240V		MD-611 380V~415V	
		B883	C51	P73	P81
		6	SCREW 5X110DB	J02537-001	
8	MOTOR BRACKET	J03314-001			
10	STATOR ASSY	J80654-001		J80656-001	
12-2	BEARING 6202ZZ #2	076202-801			
13-1	WAVE WASHER	203684-001			
13-2	WAVE WASHER	---			
14	ROTOR	J02518-001			
18	INV MOTOR ASSY	J80643-001		J80652-001	
19	TAPER PULLEY 90	J02278-001			

B. Safety cover / Sicherheitsdeckung /  
Couvercle de sécurité / Cubierta de seguridad

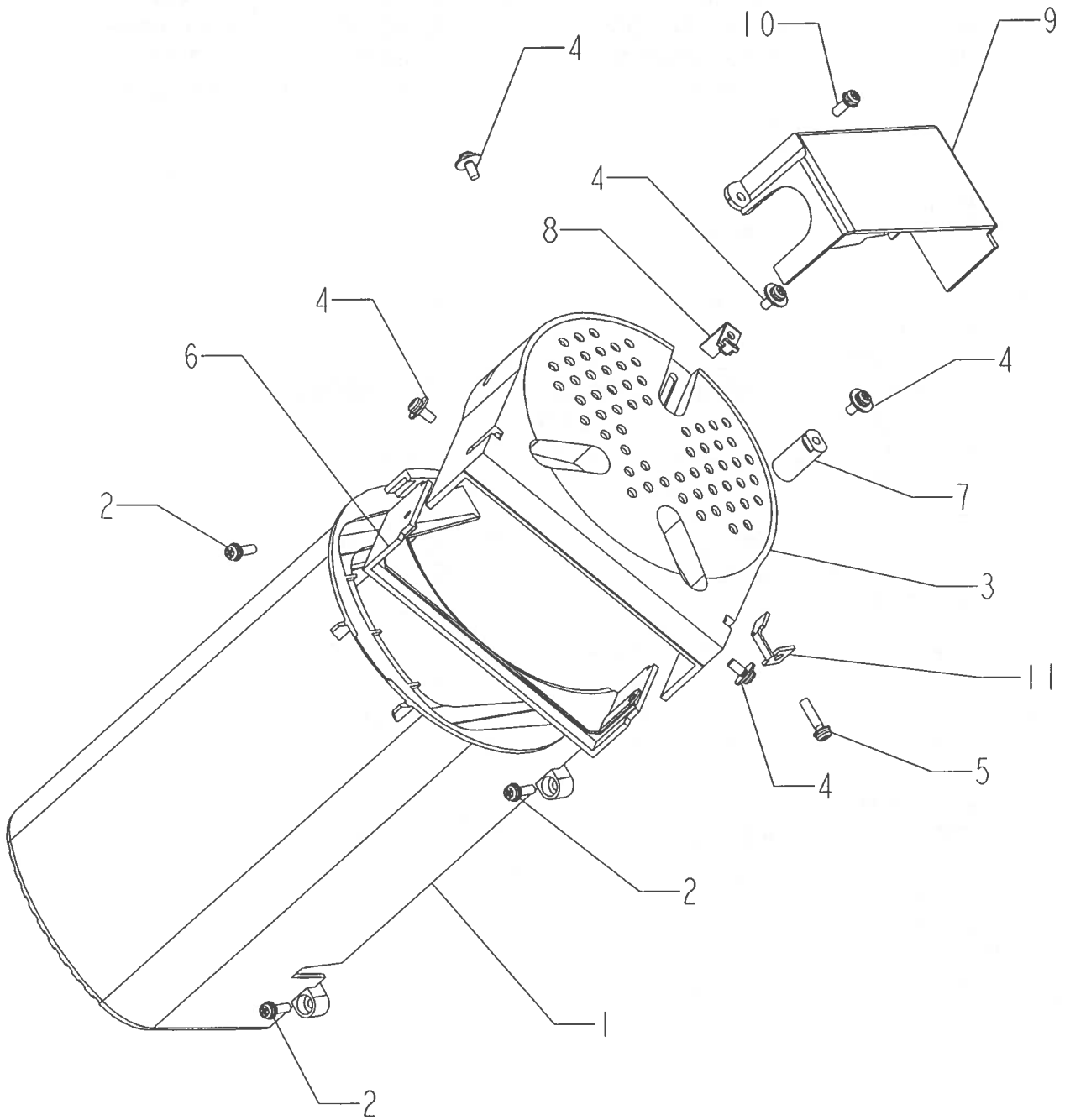

REF. NO.	CODE	Q' TY	NAME OF PARTS	REF. NO.	CODE	Q' TY	NAME OF PARTS
1	J02513-001	1	MOTOR COVER	7	J02293-001	1	FINGER GUARD
2	J00494-001	3	SCREW 4X14DA	8	J00351-001	1	BELT CLAMP PLATE 2
3	J02515-001	1	BELT COVER	9	J02508-001	1	D-CORD COVER
4	224508-001	5	SCREW 4X10DC	10	215082-001	1	SCREW 4X12DA
5	*	1	SCREW 4XL	11	*	1	BELT COVER STOPPER
6	J02516-001	1	BELT SUB COVER				

DIFFERENT PARTS LIST ( for B737 etc , LOCK , B883 , C51 , P73 , P81 , B776 , B891 , B722/4 , B877/8 )

REF. NO.	NAME OF PARTS	CODE
5	SCREW 4X18DA	217071-001
11	BELT COVER STOPPER	---

DIFFERENT PARTS LIST ( for B256 etc )

REF. NO.	NAME OF PARTS	CODE
5	SCREW 4X10DC	224508-001
11	BELT COVER STOPPER	J03039-001

C. Control box (1) / Schaltkasten (1) / Mécanisme du boîtier de contrôle (1) /  
 Mecanismo de la caja de controles (1)

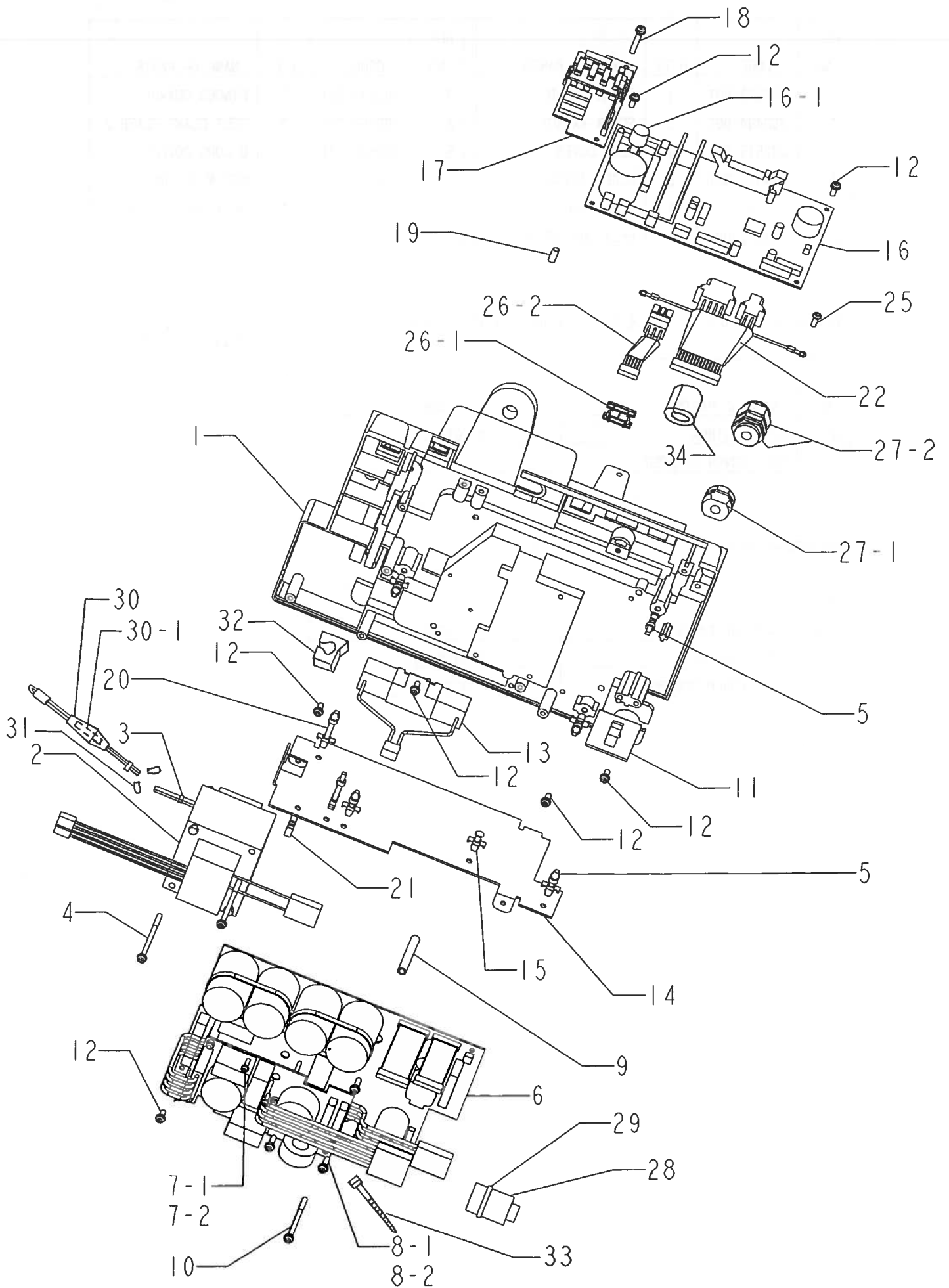



REF. NO.	CODE	Q' TY	NAME OF PARTS	REF. NO.	CODE	Q' TY	NAME OF PARTS
1	J02998-001	1	UPPER BOX	17	*	1	IMS-ASSY-SUB
2	*	1	TRANSFORMER	18	*	1	SCREW 4XL
3	*	1	TYING BAND 2. 2X85	19	*	1	COLLAR 4. 1X12. 5
4	*	2	SCREW 4XL	20	*	2	HOLDER KGLS
5	228295-001	5	HOLDER KGLS-6S	21	UG4163-000	1	WIRE SADOLE
6	*	1	IMP-ASSY	22	*	1	MAIN CONNECTOR
7-1	*	1	SCREW 4X14DA	25	229017-001	1	SCREW 4X10DA
7-2	*	2	SCREW 3X12DA	26-1	*	1	NBN PLUG CAP
8-1	*	2	SCREW 4X10DA	26-2	*	1	NBN CONNECTOR
8-2	*	3	SCREW 4X14DA	27-1	*	1	BUSSING SR-7K-2
9	*	1	COLLAR 7X45-M4	27-2	*	1	BUSSING JPG13. 5
10	*	1	SCREW 4X55DA	28	*	1	EMC FERRITE CORE
11	*	1	PLUG HOLDER	29	*	1	TYING BAND 3. 5X150
12	229017-001	7	SCREW 4X10DA	30	*	1	FUSE ASSEMBLY
13	*	1	RESIST.	30-1	*	1	FUSE (5A)
14	J02029-001	1	CIRCUIT UNIT HOLDER	31	*	2	FLAT CONNECT TERMINAL
15	J01892-001	1	HOLDER KGPS-6S	32	J03365-001	1	MOTOR CORD CAP
16	*	1	IMS-ASSY	33	220681-001	1	TYING BAND 2. 2X85
16-1	J01778-001	1	VR CONTROL KNOB	34	*	1	EMC FERRITE CORE#2

DIFFERENT PARTS LIST

REF. NO.	NAME OF PARTS	MD-601 110V	MD-601 220V-240V	MD-601 230V CE	MD-611 220V	MD-611 380V-415V	MD-611 400V CE
2	TRANSFORMER	J02502-001	J02503-001		J02664-001	J03127-001	
3	TYING BAND 2. 2X85	220681-001		---	220681-001		---
4	SCREW 4XL		J02062-001			J02514-001	
7-1	SCREW 4X14DA(B891)				---		
	(OTHER)	J00494-001			---		
7-2	SCREW 3X12DA(B891)				0A4301-205		
	(OTHER)	---			0A4301-205		
8-1	SCREW 4X10DA		229017-001				---
8-2	SCREW 4X14DA		---			J00494-001	
9	COLLAR 7X45-M4		---			J03125-001	
10	SCREW 4X55DA		---			J02062-001	
11	PLUG HOLDER		J02505-001			J02506-001	
13	RESIST.		J03288-001			J02628-001	
27-1	BUSSING SR-7K-2	J02195-001		---	J02195-001		---
27-2	BUSSING JPG13. 5	---		J03588-001	---		J03588-001

DIFFERENT PARTS LIST ( for B737 etc , LOCK , B883 , C51 , P73 , P81 , B722/4 )

REF. NO.	NAME OF PARTS	MD-601 110V	MD-601 220V-240V	MD-601 230VCE & 240V Australia	MD-611 220V	MD-611 380V-415V	MD-611 400V CE
6	IMP-ASSY	J80634-001	J80635-001	J80636-001	J80637-001	J80690-001	J80691-001

DIFFERENT PARTS LIST ( for B256 etc , B776 , B877/8 )

REF. NO.	NAME OF PARTS	MD-601 110V	MD-601 220V-240V	MD-601 230VCE & 240V Australia	MD-611 220V	MD-611 380V-415V	MD-611 400V CE
6	IMP-ASSY	J80634-001	J80722-001	J80724-001	J80723-001	J80690-001	J80691-001

DIFFERENT PARTS LIST ( for B891 )

REF. NO.	NAME OF PARTS	MD-601 110V	MD-601 220V-240V	MD-601 230VCE & 240V Australia	MD-611 220V	MD-611 380V-415V	MD-611 400V CE
6	IMP-ASSY	J80842-001	J80843-001	J80844-001	J80845-001	J80690-001	J80691-001

DIFFERENT PARTS LIST

REF. NO.	NAME OF PARTS	B737etc, LOCK, B883, C51, P73, P81, B722/4, B877/8	B256 etc	B776	B891
16	IMS-ASSY	J80852-001	J80674-001	J80762-001	J80779-001
17	IMS-ASSY-SUB	---	J80675-001	J80764-001	J80781-001
18	SCREW 4XL	---	0A4402-506	229017-001	
19	COLLAR 4. 1X12. 5	---	J03040-001		
20	HOLDER KGLS	---	J03041-001	228295-001	
22	MAIN CONNECTOR	J02497-001	J03053-001	J02497-001	J03260-001
26-1	NBN PLUG CAP		J02037-001		---
26-2	NBN CONNECTOR		---		

DIFFERENT PARTS LIST for CE ( EMC regulations )

REF. NO.	NAME OF PARTS	Industrial environment				Household environment
		B737etc, LOCK, B883, C51, P73, P81, B776, B722/4, B877/8		B256 etc, B891		B737etc, LOCK, B883, C51, P73, P81, B776, B722/4, B877/8
		MD-601 230V CE	MD-611 400V CE	MD-601 230V CE	MD-611 400V CE	MD-601 230V CE
28	EMC FERRITE CORE		---		J80631-001	---
29	TYING BAND 3. 5X150		---		J01463-001	---
34	EMC FERRITE CORE#2		---			J80796-001

OPTION PARTS

REF. NO.	NAME OF PARTS	for USA	OTHER
30	FUSE ASSEMBLY	J03122-001	J01370-001
30-1	FUSE (5A)	215822-000	
31	FLAT CONNECT TERMINAL	J00074-001	

TRANSFORMER for USA

REF. NO.	Q' TY	NAME OF PARTS	MD-601 110V	MD-611 220V
2	1			
30	1	TRANSFORMER	J03123-001	J03124-001
31	2			

D. Control box (2) / Schaltkasten (2) / Mécanisme du boîtier de contrôle (2) /  
 Mecanismo de la caja de controles (2)

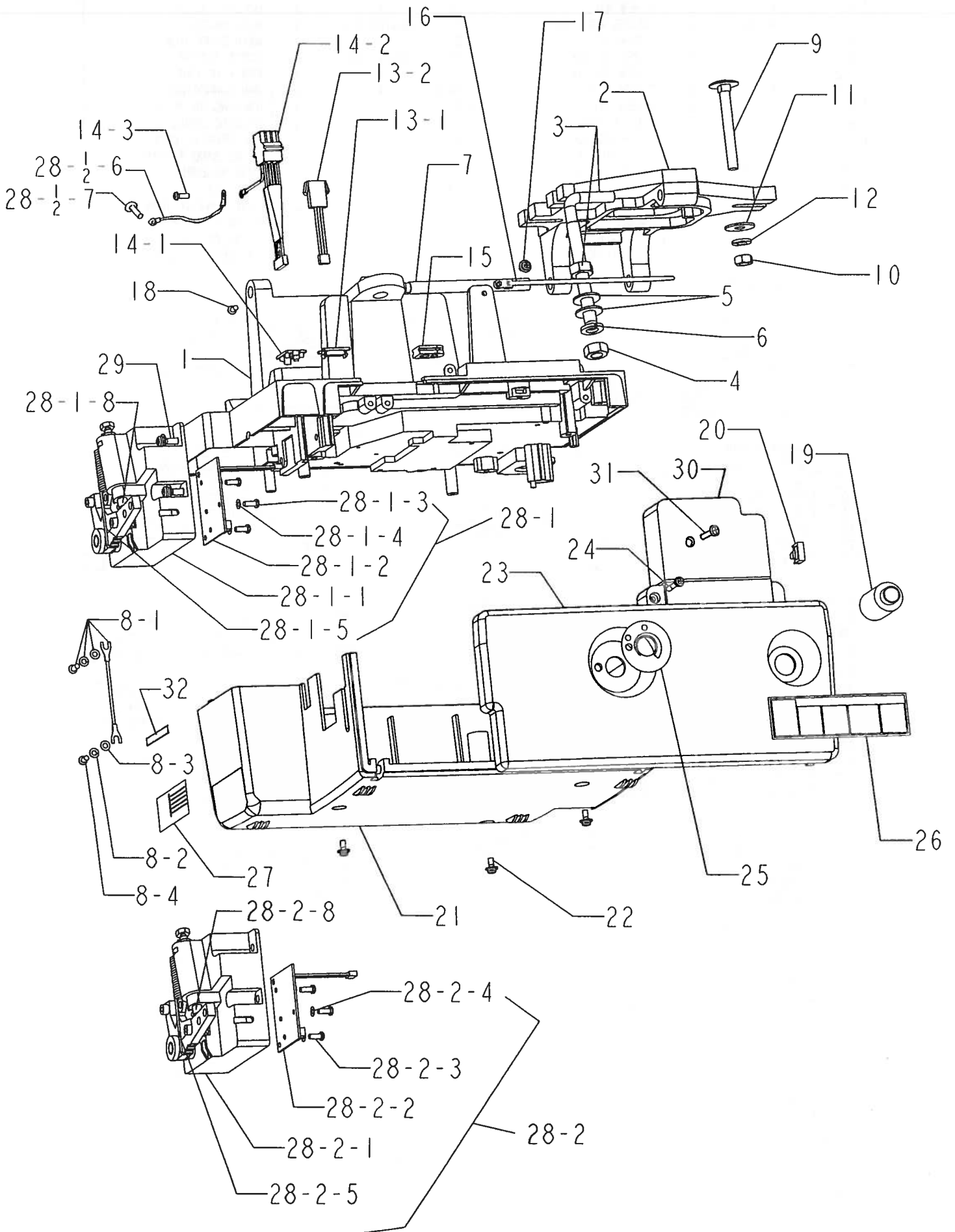

REF. NO.	CODE	Q' TY	NAME OF PARTS	REF. NO.	CODE	Q' TY	NAME OF PARTS
1	J02998-001	1	UPPER BOX	22	215081-001	3	SCREW 4X10DB
2	J00107-001	1	MD806 BASE #2	23	*	1	BOX COVER
3	J03275-001	1	BOLT(L) 10 ASSY V	24	J02568-001	1	SCREW 4X25DA
4	021100-206	1	NUT 2-10	25	*	1	VR LABEL
5	025100-236	2	PLAIN WASHER 10	26	S38352-101	1	WARNING LABEL
6	028100-246	1	SPRING WASHER 2-10	27	---	1	NAME PLATE
7	J02517-001	1	PIN 9.9X116	28-1	J80639-001	1	TREADLE UNIT DOMES.
8-1	J02832-001	1	EARTH CORD ASSY	28-1-1	J03413-001	1	TREADLE BASE ASSY
8-2	028040-245	1	SPRING WASHER 2-4	28-1-2	J80640-001	1	PS CIRCUIT BOARD
8-3	025040-173	1	PLAIN WASHER 4	28-1-3	037401-015	3	SCREW 4X10
8-4	062401-063	1	SCREW 4X10	28-1-4	J02130-001	3	SPRING WASHER 03X4.3
9	222372-001	3	BOLT 8X70	28-1-5	J00649-001	1	SPRING
10	021080-206	3	NUT 2-8	28-1-6	J03417-001	1	EARTH CORD ASSY
11	025080-336	3	PLAIN WASHER 8	28-1-7	229017-001	1	SCREW 4X10DA
12	028080-246	3	SPRING WASHER 2-8	28-1-8	228260-001	1	PRESSER BAR #3
13-1	*	1	MVR PLUG CAP	28-2	*	1	TREADLE UNIT EXPORT.
13-2	*	1	MVR CONNECTOR	28-2-1	*	1	TREADLE BASE ASSY
14-1	*	1	FOOT PLUG CAP	28-2-2	J80640-001	1	PS CIRCUIT BOARD
14-2	*	1	FOOT CONNECTOR	28-2-3	037401-015	3	SCREW 4X10
14-3	229017-001	1	SCREW 4X10DA	28-2-4	J02130-001	3	SPRING WASHER 03X4.3
15	J02036-001	1	CORD BUSH	28-2-5	J00649-001	1	SPRING
16	J03033-001	1	TYING BAND T30MR	28-2-6	J03417-001	1	EARTH CORD ASSY
17	215081-001	1	SCREW 4X10DB	28-2-7	229017-001	1	SCREW 4X10DA
18	002400-806	1	SCREW 4X8	28-2-8	228260-001	1	PRESSER BAR #3
19	*	1	EMC FERRITE CORE	29	J00353-001	3	SCREW 5X14DB
20	*	1	WIRE SADOLE	30	*	1	BOX COVER-S
21	J02027-001	1	LOWER BOX	31	*	1	SCREW 4X25DA
				32	*	1	LABEL C-TICK

DIFFERENT PARTS LIST

REF. NO.	NAME OF PARTS	B737etc, LOCK, B883, C51, P73, P81, B776, B722/4, B877/8		B256 etc	B891
		STANDARD	for Canada		
20	WIRE SADOLE	---		UG4163-000	---
23	BOX COVER	J02028-001	J02955-001	J03044-001	J02955-001
25	VR LABEL	J02501-001		J03045-001	J02501-001
30	BOX COVER-S	---			J03316-001
31	SCREW 4X25DA	---			J02568-001

(for H. K. J02501-002)

DIFFERENT PARTS LIST

REF. NO.	NAME OF PARTS	STANDARD	OPTION
13-1	MVR PLUG CAP	J02038-001	---
13-2	MVR CONNECTOR	---	J02495-001
14-1	FOOT PLUG CAP	J02039-001	---
14-2	FOOT CONNECTOR	---	J02496-001

DIFFERENT PARTS LIST

REF. NO.	NAME OF PARTS	for Australia	OTHER
32	LABEL C-TICK	UF8582-001	---

DIFFERENT PARTS LIST

REF. NO.	NAME OF PARTS	for Hong Kong	OTHER
28-2	TREADLE UNIT EXPORT.	J80857-001	J80638-001
28-2-1	TREADLE BASE ASSY	J03593-001	J03419-001

DIFFERENT PARTS LIST for CE ( EMC regulations )

REF. NO.	NAME OF PARTS	Industrial environment				Household environment
		B737etc, LOCK, B883, C51, P73, P81, B776, B722/4, B877/8		B256 etc, B891		B737etc, LOCK, B883, C51, P73, P81, B776, B722/4, B877/8
		MD-601 230V CE	MD-611 400V CE	MD-601 230VCE & 240V Australia	MD-611 400V CE	MD-601 230V CE
19	EMC FERRITE CORE	---		J80631-001	---	

E. Operation panel, switch box mechanism (1) / Schaltkasten (1) /  
Boîtier d'interrupteurs (1) / Caja de interruptores (1)

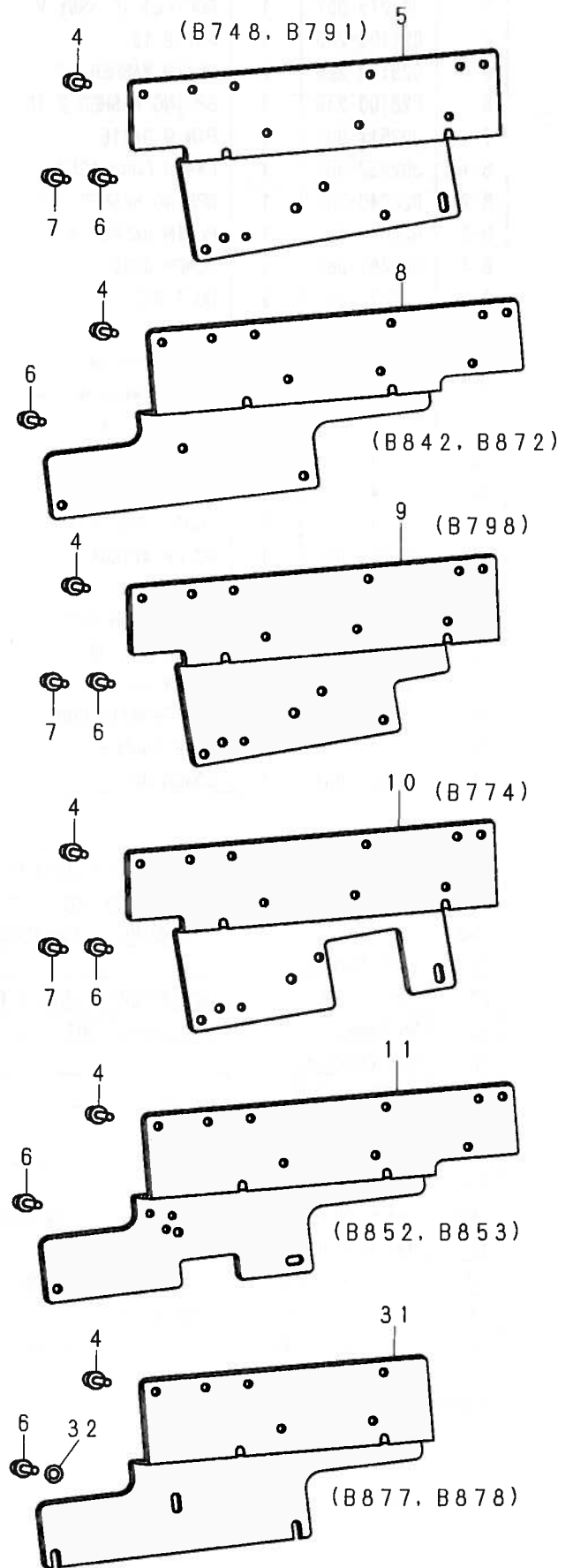
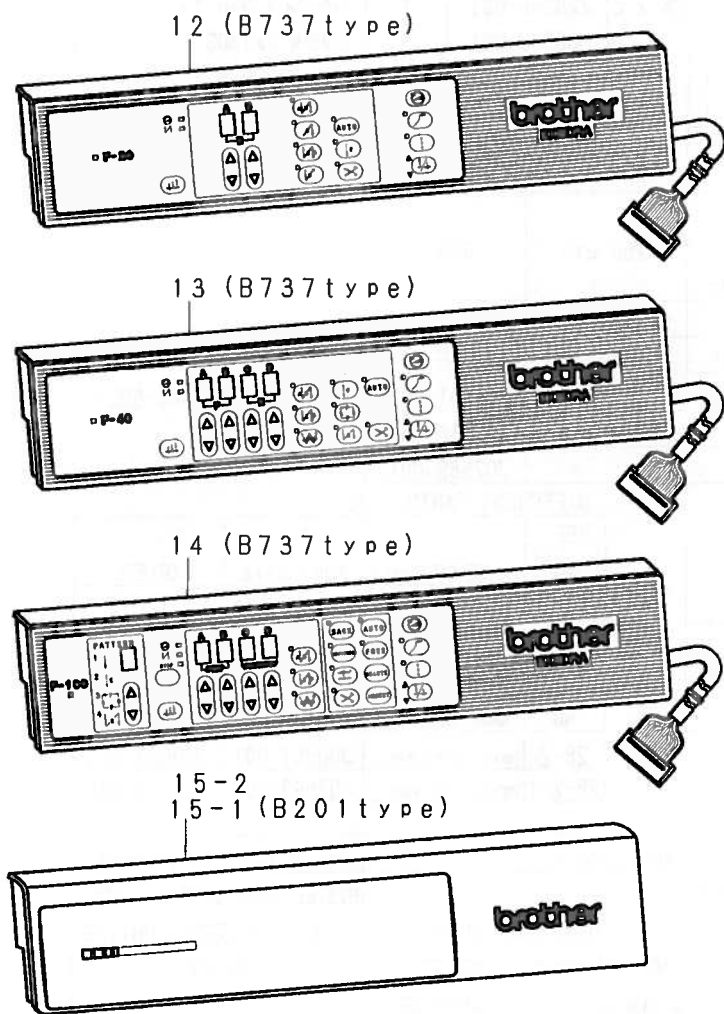
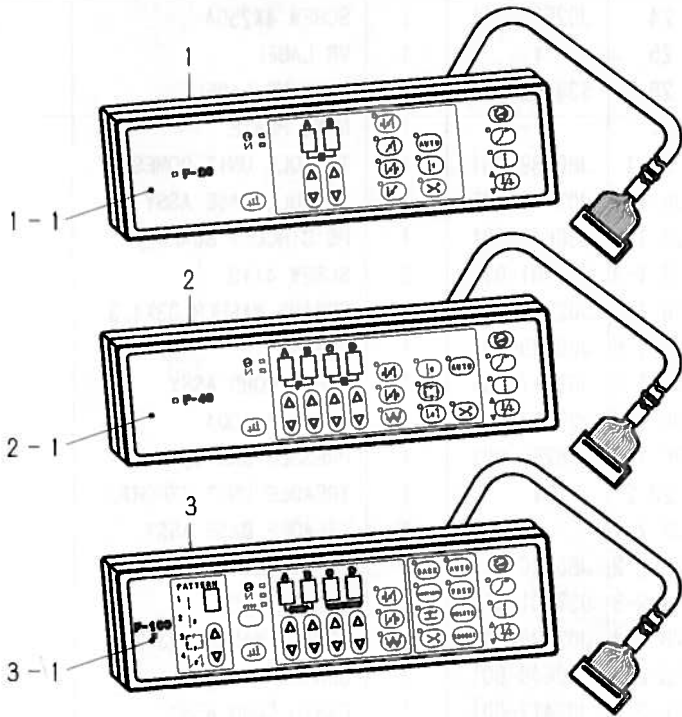

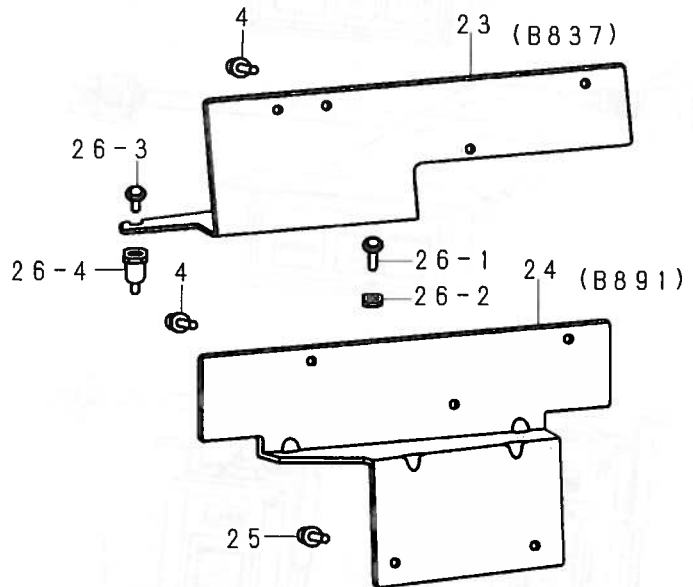
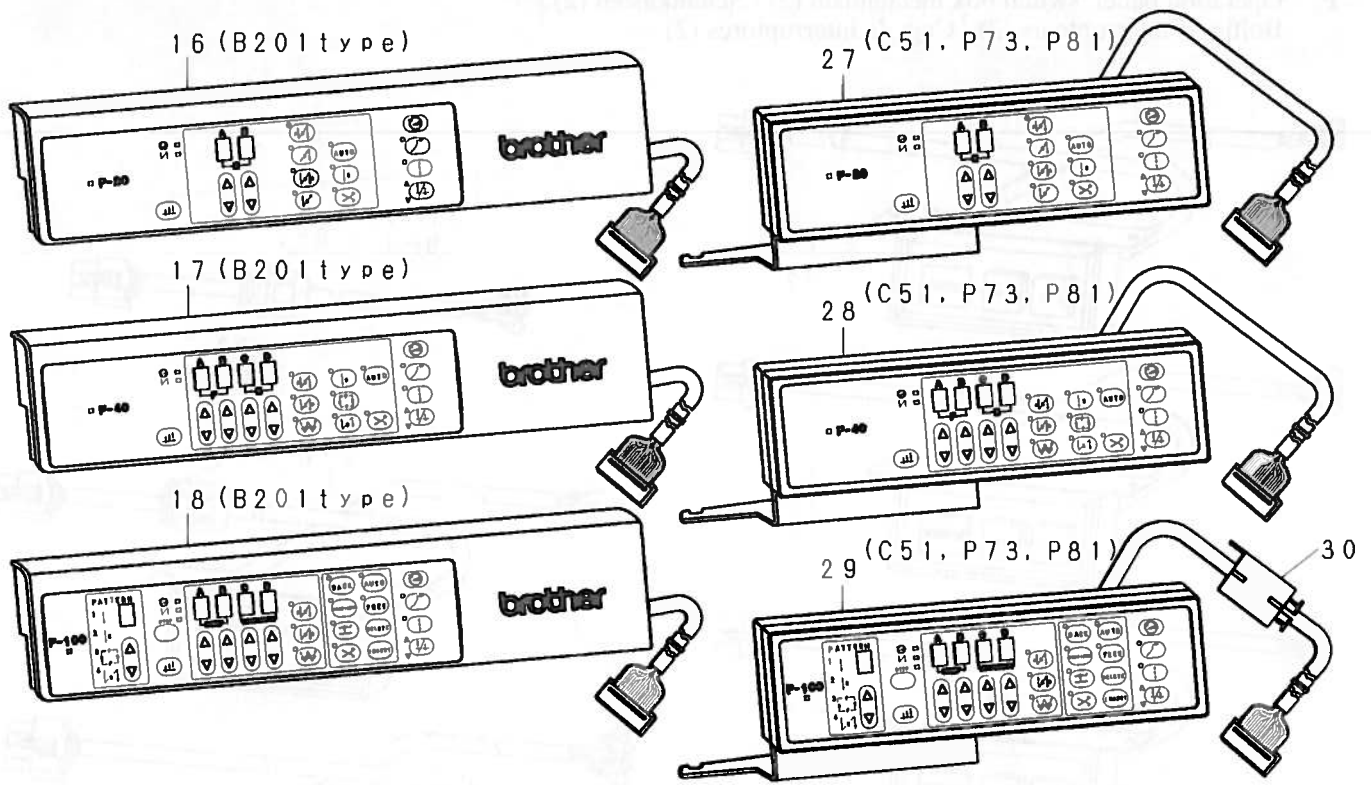

REF. NO.	CODE	Q'TY	NAME OF PARTS
1	137207-71110	1	F-20 OPERATION PANEL
1-1	J01990-001	1	F-20 PANEL PLATE
2	137207-71210	1	F-40 OPERATION PANEL
2-1	J01989-001	1	F-40 PANEL PLATE
3	137207-71310	1	F-100 OPERATION PANEL
3-1	J01988-001	1	F-100 PANEL PLATE
4	215081-002	3	SCREW 4X10DB
5	J02058-001	1	HB-SETTING PLATE#F1
6	062681-212	3	SCREW 437-40X12
7	062671-212	3	SCREW 357-40X12
8	J02059-001	1	HB-SETTING PLATE#F3
9	J02054-001	1	HB-SETTING PLATE#F1-2
10	J02566-001	1	HB-SETTING PLATE#F2
11	J02567-001	1	HB-SETTING PLATE#F5
12	137207-71111	1	F-20 OPERATION PANEL
13	137207-71211	1	F-40 OPERATION PANEL
14	137207-71311	1	F-100 OPERATION PANEL
15-1	J80633-001	1	BF-0 OPERATION PANEL
15-2	J80899-001	1	BF-0 OPERATION PANEL TR
16	137207-81111	1	BF-20 OPERATION PANEL
17	137207-81211	1	BF-40 OPERATION PANEL
18	137207-81311	1	BF-100 OPERATION PANEL
23	J02061-001	1	HB-SETTING PLATE#F6
24	J03278-001	1	HB-SETTING PLATE#F7

REF. NO.	CODE	Q'TY	NAME OF PARTS
25	215082-003	2	SCREW 4X12DA
26-1	062401-605	1	SCREW 4X16
26-2	021400-205	1	NUT 2-4
26-3	224508-001	2	SCREW 4X10DC
26-4	---	2	STUD SM4. 37X29
27	137207-71112	1	F-20 OPERATION PANEL SE
28	137207-71212	1	F-40 OPERATION PANEL SE
29	137207-71312	1	F-100 OPERATION PANEL SE
30	J80631-001	1	EMC FERRITE CORE
31	J03555-001	1	HB-SETTING PLATE#F3-2
32	025680-232	3	PLAIN WASHER 4.37

DIFFERENT PARTS LIST for CE ( EMC regulations )

REF. NO.	CODE	Industrial environment		Household environment	
		B737etc, LOCK, B883, C51, P73, P81, B776, B722/4, B877/8	B256 etc, B891	B737etc, LOCK, B883, C51, P73, P81, B776, B722/4, B877/8	B737etc, LOCK, B883, C51, P73, P81, B776, B722/4, B877/8
		1-230VCE, 3-400VCE		1-230VCE	
30	J80631-001	Not necessary		Necessary	

F. Operation panel, switch box mechanism (2) / Schaltkasten (2) /  
 Boîtier d'interrupteurs (2) / Caja de interruptores (2)

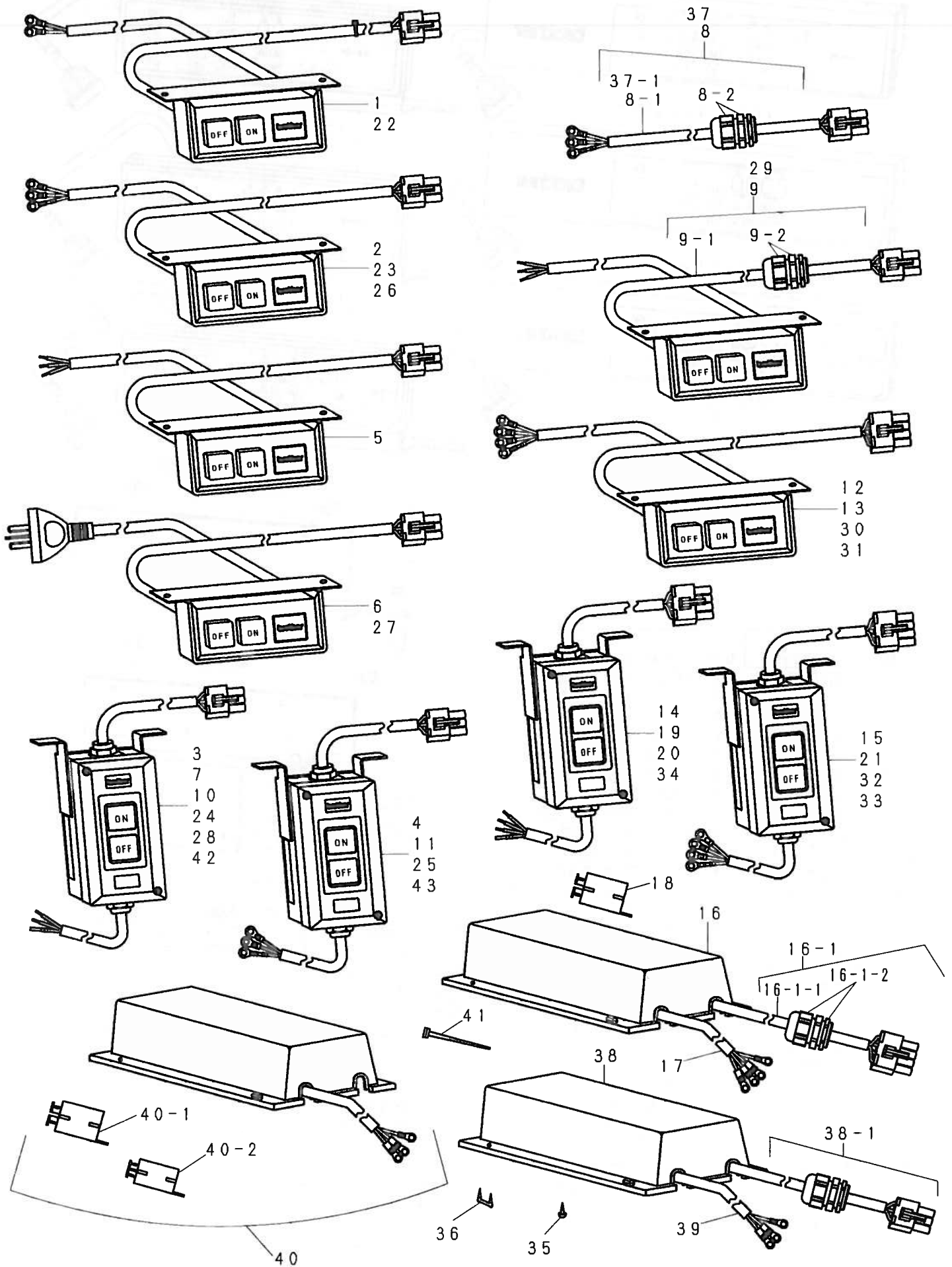

REF. NO.	CODE	Q' TY	NAME OF PARTS	VOLTAGE , TYPE
1	229240-001	1	2PSWITCH ASSEMBLY#19-3	1-110 V
2	230542-001	1	2PSWITCH ASSEMBLY#19-4	1-110 V , SJT (Canada)
3	J02045-001	1	2PSWITCH ASSEMBLY#24	1-110 V , OCR (USA)
4	237272-001	1	2PSWITCH ASSEMBLY#16-3	1-110 V , SJT OCR (Canada)
5	J01244-001	1	2PSWITCH ASSEMBLY#31-2	1-220 V ~ 240 V
6	236127-001	1	2PSWITCH ASSEMBLY#19-7	1-240 V , SAA (Australia, New Zealand)
7	J02046-001	1	2PSWITCH ASSEMBLY#25	1-220 V , OCR
8	J03134-001	1	3P PLUG ASSEMBLY#10K32	1-230 V , CE (Europe)
8-1	J02302-001	1	3P PLUG ASSEMBLY#10-32	
8-2	J03588-001	1	BUSSING JPG13.5	
9	J03238-001	1	2PSWITCH ASSEMBLY#31K2	1-230 V (Greece)
9-1	J01244-001	1	2PSWITCH ASSEMBLY#31-2	
9-2	J03588-001	1	BUSSING JPG13.5	
10	J03239-001	1	2PSWITCH ASSEMBLY IN#1-1	COV 1-110 V , OCR (USA)
11	J03241-001	1	2PSWITCH ASSEMBLY IN#1-2	COV 1-110 V , SJT OCR (Canada)
12	229250-001	1	3PSWITCH ASSEMBLY#11-7	3-220 V ~ 415 V
13	230545-001	1	3PSWITCH ASSEMBLY#11-8	3-220 V , SJT (Canada)
14	J02047-001	1	3PSWITCH ASSEMBLY#15	3-220 V , OCR (USA)
15	237273-001	1	3PSWITCH ASSEMBLY#9-16	3-220 V , SJT OCR (Canada)
16	J80727-001	1	EMC BOX ASSEMBLY#3	3-400 V , CE (Europe)
16-1	J03135-001	1	4P PLUG ASSEMBLY#11K	
16-1-1	228272-001	1	4P PLUG ASSEMBLY#11	
16-1-2	J03588-001	1	BUSSING JPG13.5	
17	J02678-001	1	ELECTRIC SUPPLY CORD#5	3-400 V , CE (Europe)
18	J80631-001	1	EMC FERRITE CORE	3-400 V , CE (Europe)
19	J03245-001	1	3PSWITCH ASSEMBLY IN#3-3	3-380 V , OCR (South Africa)
20	J03240-001	1	3PSWITCH ASSEMBLY IN#3-1	COV 3-220 V , OCR (USA)
21	J03242-001	1	3PSWITCH ASSEMBLY IN#3-2	COV 3-220 V , SJT OCR (Canada)
22	J00452-001	1	2PSWITCH ASSEMBLY#19-23	B883 1-110 V
23	J00455-001	1	2PSWITCH ASSEMBLY#19-24	B883 1-110 V , SJT (Canada)
24	J00453-001	1	2PSWITCH ASSEMBLY#16-12	B883 1-110 V , OCR (USA)
25	J00457-001	1	2PSWITCH ASSEMBLY#16-23	B883 1-110 V , SJT OCR (Canada)
26	J00460-001	1	2PSWITCH ASSEMBLY#19-22	B883 1-220 V ~ 240 V
27	J00464-001	1	2PSWITCH ASSEMBLY#19-27	B883 1-240 V , SAA (Australia)
28	J00462-001	1	2PSWITCH ASSEMBLY#22-11	B883 1-220 V , OCR
29	J03247-001	1	2PSWITCH ASSEMBLY#31L2	B883 1-230 V (Greece)
30	J00470-001	1	3PSWITCH ASSEMBLY#11-17	B883 3-220 V ~ 415 V
31	J00473-001	1	3PSWITCH ASSEMBLY#11-18	B883 3-220 V , SJT (Canada)
32	J02432-001	1	3PSWITCH ASSEMBLY#15-21	B883 3-220 V , OCR (USA)
33	J00477-001	1	3PSWITCH ASSEMBLY#9-26	B883 3-220 V , SJT OCR (Canada)
34	J03246-001	1	3PSWITCH ASSEMBLY IN#3-4	B883 3-380 V , OCR (South Africa)
35	S03816-001	2	SCREW 4.5X16	
36	200190-001	5	STEPLE	
37	J03313-001	1	3P PLUG ASSEMBLY#10K22	B883 1-230 V , CE (Europe)
37-1	J00461-001	1	3P PLUG ASSEMBLY#10-22	
38	J80783-001	1	EMC BOX ASSEMBLY#4	1-230 V , CE (Europe)
38-1	J03134-001	1	3P PLUG ASSEMBLY#10K32	
39	J02679-001	1	ELECTRIC SUPPLY CORD	1-230 V , CE (Europe)
40	J80795-001	1	EMC BOX + EMC CORE SET	1-230 V , CE (Europe)
40-1	J80631-001	3	EMC FERRITE CORE	
40-2	J80796-001	1	EMC FERRITE CORE #2	
41	220681-001	1	TYING BAND 2.2X85	CE (Europe)
42	J03392-001	1	2PSWITCH ASSEMBLY IN#1-3	COV 1-220 V , OCR
43	J03393-001	1	2PSWITCH ASSEMBLY IN#1-4	COV 1-220 V , SJT OCR

DIFFERENT PARTS LIST for CE ( EMC regulations )

REF. NO.	NAME OF PARTS	Industrial environment				Household environment
		B737etc, LOCK, C51, P73, P81, B722/4, B877/8, B776, B256, B891		B883		B737etc, LOCK, B883, C51, P73, P81, B722/4, B877/8, B776
		1-230V CE	3-400V CE	1-230V CE	3-400V CE	1-230V CE
8	3P PLUG ASSY#10K32	J03134-001	---	---	---	---
16	EMC BOX ASSEMBLY#3	---	J80727-001	---	J80727-001	---
17	ELEC. SUPPLY CORD#5	---	J02678-001	---	J02678-001	---
41	TYING BAND 2.2X85	---	220681-001	---	220681-001	---
18	EMC FERRITE CORE	---	J80631-001	---	J80631-001	---
37	3P PLUG ASSY#10K22	---	---	J03313-001	---	---
38	EMC BOX ASSEMBLY#4	---	---	---	---	J80783-001
39	ELECTRIC SUPPLY CORD	---	---	---	---	J02679-001
41	TYING BAND 2.2X85	---	---	---	---	220681-001
18	EMC FERRITE CORE	---	---	---	---	J80631-001
18	EMC FERRITE CORE	---	---	---	---	J80631-001
41	TYING BAND 2.2X85	---	---	---	---	220681-001

G. Material edge sensor related (option) (1) / Für Materialkantensensor (Sonderausstattung) (1) /  
 Capteur de bord de tissu relatif (en option) (1) /  
 Piezas relacionadas al detector de borde de tejidos (opcional) (1)

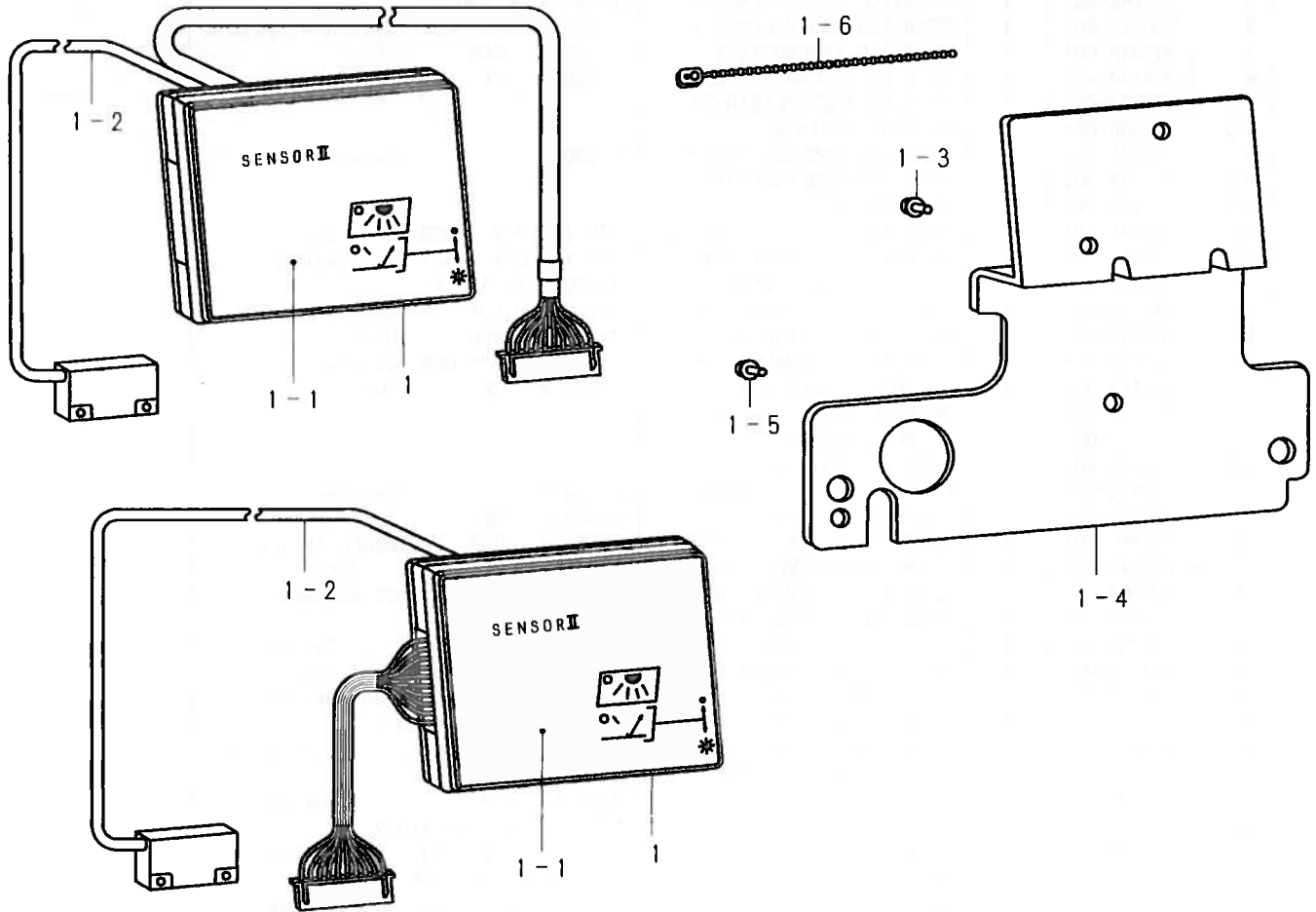

SENSOR 2 SET

REF. NO.	MACHINE MODEL	S 2 ( F-20 ~ F-100 )	
		NAME OF PARTS	CODE
1	B737, B748A	SENSOR #2-2	291657-013
	B748	SENSOR #2-1	291659-011
	TWIN NEEDLE	SENSOR #2-3	291674-011
	B791	SENSOR #2-4	291640-011
	B798	SENSOR #2-6	291642-011
	B774	SENSOR #2-7	388706-011
B722	SENSOR #2-41	J80793-001	

DIFFERENT PARTS LIST

REF. NO.	MACHINE MODEL	B722
	NAME OF PARTS	SENSOR #2-41
1-1	EMBLEM PLATE	233268-002
1-2	SENSOR CORD ASSY.	233263-001
1-3	SCREW 4X10DB	215081-002
1-4	SETTING PLATE	237043-002
1-5	SCREW 437-40X12	062681-212
1-6	TYING BAND N-108	233501-001

DIFFERENT PARTS LIST

REF. NO.	MACHINE MODEL	B737, B748A	B748	TWIN NEEDLE	B791	B798	B774
		NAME OF PARTS	SENSOR #2-2	SENSOR #2-1	SENSOR #2-3	SENSOR #2-4	SENSOR #2-6
1-1	EMBLEM PLATE	233268-002					
1-2	SENSOR CORD ASSY.	233263-001			233619-001	233263-001	
1-3	SCREW 4X10DB	215081-002					
1-4	SETTING PLATE	237043-002	---				
1-5	SCREW 437-40X12	062681-212	---				
1-6	TYING BAND N-108	233501-001					



H. Material edge sensor related (option) (2) / Für Materialkantensensor (Sonderausstattung) (2) /  
 Capteur de bord de tissu relatif (en option) (2) /  
 Piezas relacionadas al detector de borde de tejidos (opcional) (2)

(B737, B748, B748A)

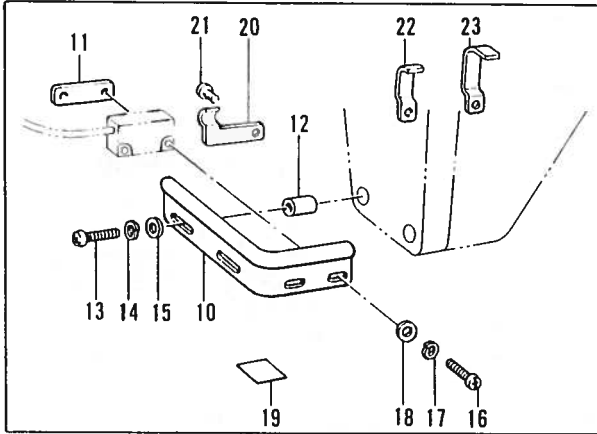

(B842, B872)

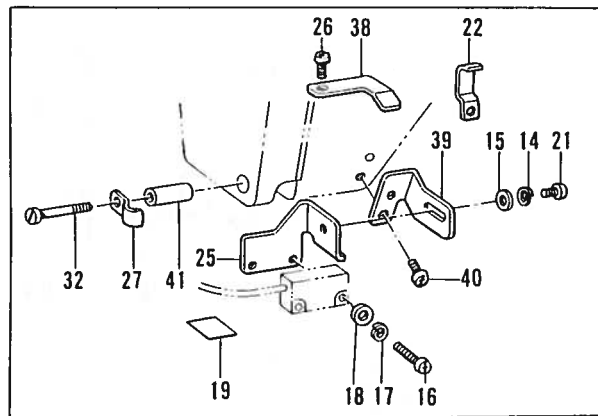
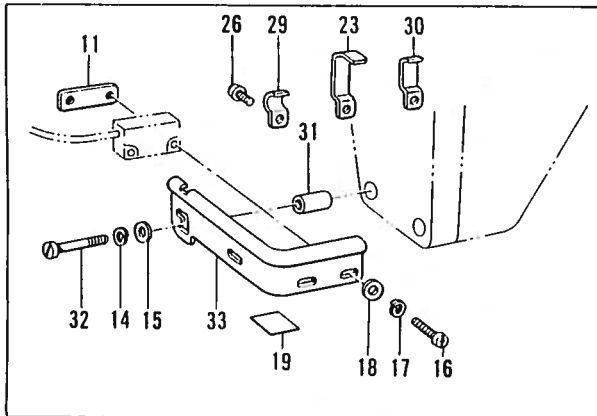
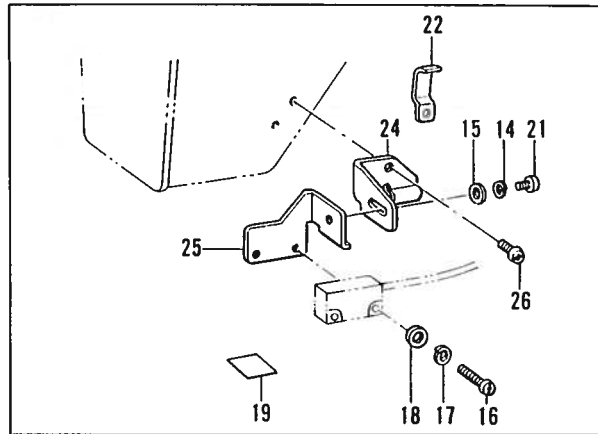

(B791, B722)

(B798)

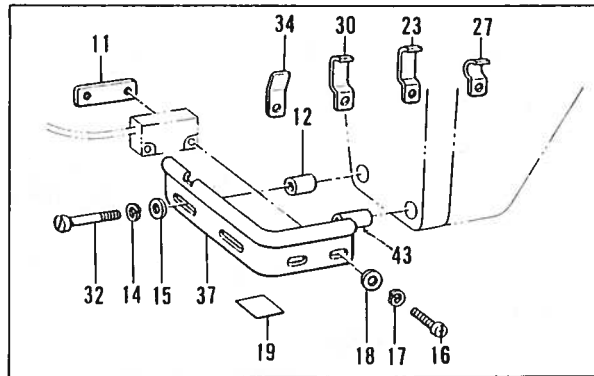

(B774)

REF. NO.	CODE	Q' TY	NAME OF PARTS	REF. NO.	CODE	Q' TY	NAME OF PARTS
10	233091-002	1	SENSOR PLATE	25	233544-001	1	SENSOR SETTING PLATE#3
11	233092-001	1	SENSOR SETTING PLATE	26	062680-812	2	SCREW 437-40X8
12	233067-001	2	SENSOR SETTING COLLAR	27	S02701-001	2	CORD HOLDER#U1
13	062672-012	2	SCREW 357-40X20	29	233604-001	1	CORD HOLDER#2
14	028350-242	2	SPRING WASHER 2-3. 5	30	142268-001	2	CORD HOLDER#L
15	026350-132	2	WASHER 3. 5	31	233575-001	2	SENSOR SETTING COLLAR#2
16	062301-402	2	SCREW 3X14	32	151431-001	2	SCREW 3. 57
17	028030-242	2	SPRING WASHER 2-3	33	233573-001	1	SENSOR PLATE#B791
18	025030-132	2	WASHER 3	34	233618-001	1	CORD HOLDER#3
19	233063-001	1	ALUMI SHEET	37	233574-001	1	SENSOR PLATE#B793
20	233500-001	1	CORD HOLDER	38	233696-001	1	CORD HOLDER#4
21	062670-612	1	SCREW 357-40X6	39	233694-001	1	SENSOR PLATE#B798
22	S02702-101	2	CORD HOLDER#U2	40	062670-812	1	SCREW 357-40X8
23	S02703-001	2	CORD HOLDER#U3	41	233695-001	1	SENSOR SETTING COLLAR#3
24	233545-001	1	SENSOR HOLDER#A	43	236315-001	1	SENSOR COLLAR 17. 5

I. Pedal for standing operation / Fusstritt für stehenden Arbeitsplatz /  
 Pédale pour opération en station debò / Pedal para operar de pie

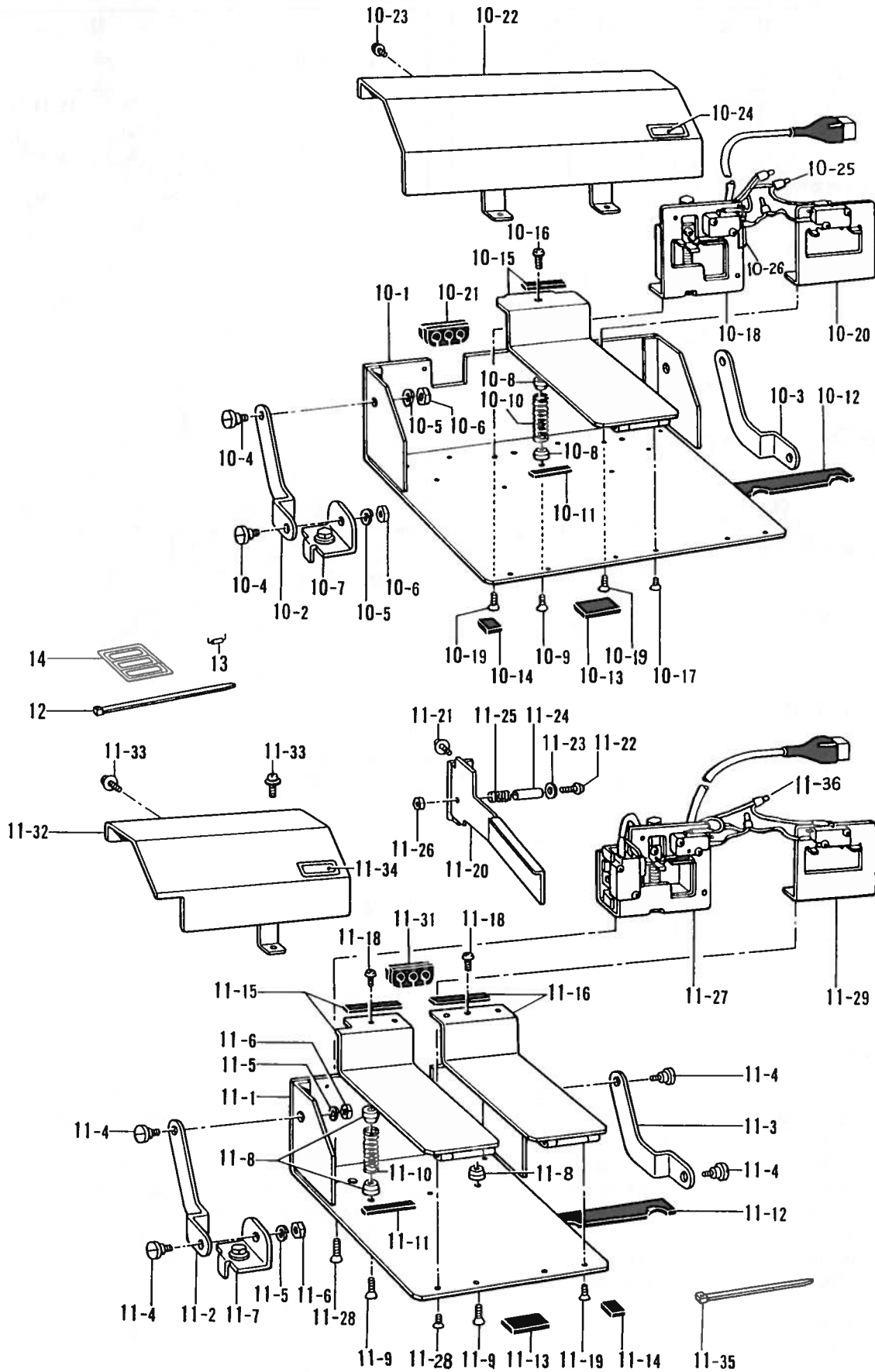

PEDAL FOR STANDING OPERATION  
(VARIABLE SPEED TYPE) (TWO SPEED TYPE)

REF. NO.	CODE	Q' TY	NAME OF PARTS
10	*	1	PEDAL ASSEMBLY
10-1	233217-002	1	PEDAL BASE ASSEMBLY
10-2	233221-003	1	ARM CLAMP#L
10-3	233222-003	1	ARM CLAMP#R
10-4	233223-001	4	STUD SCREW 8X16.7
10-5	028080-242	4	SPRING WASHER 2-8
10-6	021080-302	4	NUT 8
10-7	233224-002	2	PEDAL CLAMP ASSEMBLY
10-8	233231-001	6	SPRING CUSHION#23
10-9	061401-205	3	SCREW 4X12
10-10	233233-001	3	SPRING 1.2X12X57
10-11	233232-001	3	RUBBER PLATE1.6X5X45
10-12	233228-001	1	RUBBER PLATE3.2X20X286
10-13	233229-001	2	RUBBER PLATE3.2X20X46
10-14	233230-001	2	RUBBER PLATE3.2X20X15
10-15	238188-001	3	PEDAL ASSEMBLY PRESSER
10-16	217093-001	3	SCREW 4X12D
10-17	061400-402	6	SCREW 4X4
10-18	*	1	SPEED CONTROLLER
10-19	061401-205	6	SCREW 4X12
10-20	J02950-001	2	M. SWITCH ASSEMBLY
10-21	233250-001	1	F. P BUSH
10-22	233251-003	1	PEDAL COVER
10-23	233236-001	4	SCREW 4X6DA
10-24	*	1	IDENTIFICATION LABEL
10-25	J01585-001	3	FLAT CONNECTOR CE1
10-26	233516-001	1	EDGGING 2.4X40
12	233491-001	2	TYING BAND 3.6X203
13	200190-001	4	STEPL
14	233515-001	1	LABEL

DIFFERENT PARTS LIST

REF. NO.	VARIABLE SPEED TYPE	TWO SPEED TYPE
10	J80380-040	J80630-001
10-18	J01855-001	J02949-001
10-24	233487-002	233488-002

PEDAL FOR STANDING OPERATION  
(SIDE ACTION AND VARIABLE SPEED TYPE)

REF. NO.	CODE	Q' TY	NAME OF PARTS
11	J80081-040	1	PEDAL THREAD TRIM #6
11-1	238194-001	1	PEDAL BASE ASSEMBLY#5
11-2	233221-003	1	ARM CLAMP#L
11-3	233222-003	1	ARM CLAMP#R
11-4	233223-001	4	STUD SCREW 8X16.7
11-5	028080-242	4	SPRING WASHER 2-8
11-6	021080-302	4	NUT 8
11-7	233224-002	2	PEDAL CLAMP ASSEMBLY
11-8	233231-001	4	SPRING CUSHION#23
11-9	061401-205	2	SCREW 4X12
11-10	233233-001	2	SPRING 1.2X12X57
11-11	233232-001	2	RUBBER PLATE1.6X5X45
11-12	S14823-001	1	RUBBER PLATE3.2X20X186
11-13	233229-001	1	RUBBER PLATE3.2X20X46
11-14	233230-001	2	RUBBER PLATE3.2X20X15
11-15	238186-001	1	PEDAL ASSEMBLY (SREED)
11-16	238188-001	1	PEDAL ASSEMBLY PRESSER
11-18	217093-001	1	SCREW 4X12D
11-19	061400-402	4	SCREW 4X4
11-20	238191-001	1	PEDAL TRIMMER ASS.#2
11-21	225534-001	2	SCREW 4X8DA
11-22	062402-005	1	SCREW 4X20
11-23	025040-335	1	WASHER 4
11-24	J00021-001	1	TUBE T5X12
11-25	228957-001	1	SPRING 8X30
11-26	021400-305	1	NUT 4
11-27	J01084-001	1	SPEED CONTROLLER#6
11-28	061401-205	4	SCREW 4X12
11-29	J02950-001	1	M. SWITCH ASSEMBLY
11-31	233250-001	1	F. P BUSH
11-32	238196-001	1	PEDAL COVER#5
11-33	233236-001	3	SCREW 4X6DA
11-34	J01089-001	1	IDENTIFICATION LABEL
11-35	228475-000	2	TYING BAND 1.9X80
11-36	J00074-001	2	FLAT CONNECTOR CE2
12	233491-001	2	TYING BAND 3.6X203
13	200190-001	4	STEPL
14	233515-001	1	LABEL

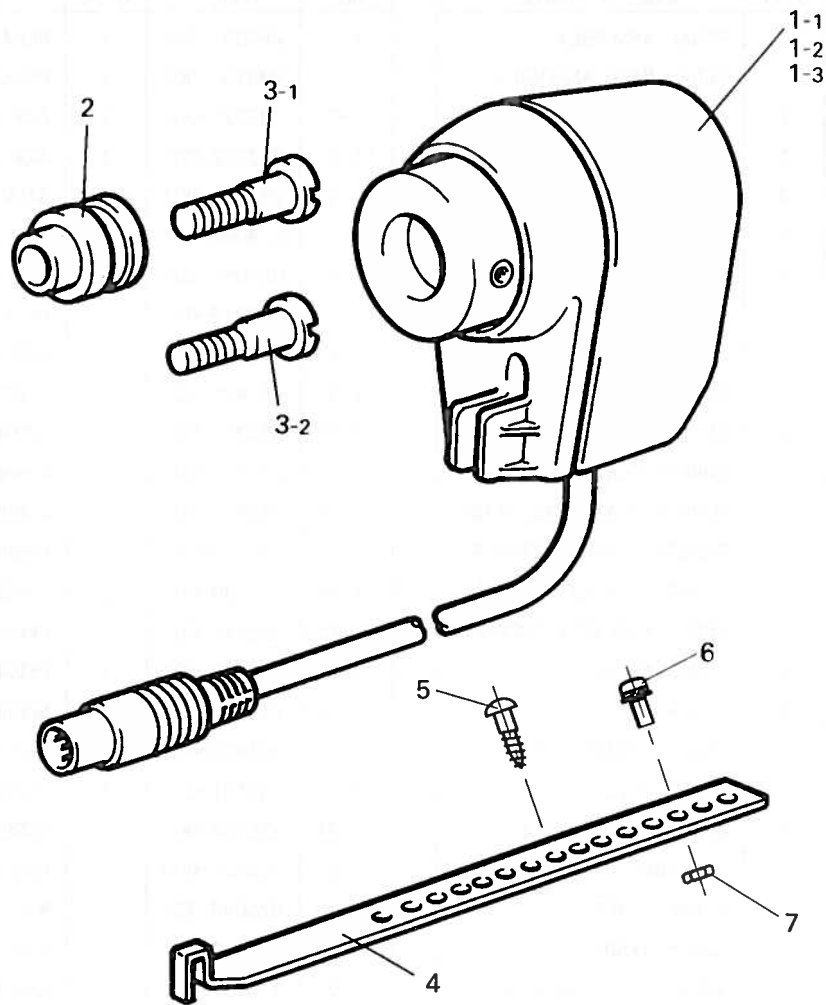

DIFFERENT PARTS LIST

REF. NO.	MACHINE MODEL		Over lock, B256	B891	C51, P73, P81
	NAME OF PARTS	Q' TY	CODE	CODE	CODE
1-1	SYNCHRONIZER ASSY#17-2	1	J80347-001	---	---
1-2	SYNCHRONIZER ASSY#17UF	1	---	J80777-001	---
1-3	SYNCHRONIZER ASSY#17G8	1	---	---	J80859-001
2	SYNCHRO. BOSS 22.2	1	J01251-001	---	---
3-1	SCREW 11/32-28 (B, M)	1	J01252-001	---	---
3-2	SCREW 5/16-24 (J, S, A)	1	J01253-001	---	---
4	SYNCHRONIZER GUIDE	1	J01473-001	---	---
5	SCREW 4.5X16	2	S03816-001	---	---
6	SCREW 4X10DA	1	229017-001	---	---
7	NUT 3-4	1	021400-303	---	---

DIFFERENT PARTS LIST / ZUBEHÖRLISTE /  
LISTE DES PIÈCES ACCESSOIRES / LISTA DE PIEZAS ACCESORIAS

Machine Model		B737 etc						
Ref. No.	Sub-Class	Single Phase				Three Phase		
		Voltage (V)	110	220 ~ 240	240 Australia	230 CE	220	380 ~ 415
A-18	INV Motor Assembly	J80643-001				J80652-001		
A-19	Taper Pulley	J02278-001						
	Q90	J02281-001						
C-6	Power Circuit Unit	J80634-001	J80635-001	J80636-001		J80637-001	J80690-001	J80691-001
C-16	Control Circuit Unit	J80852-001						
F-1~ F-43	Switch Assembly	229240-001	J01244-001	236127-001 (Australia)	J03134-001 (3P Plug A.)	229250-001		J80727-001 (EMC BOX) + J02678-001 +220681-001 + J80631-001 (EMC CORE)
		J02045-001 (USA)	J02046-001 (OCR)		J80783001+	J02047-001 (USA)	J03245-001 (OCR)	
		230542-001 (Canada)	236127-001 (New Zealand)		J02679001+	230545-001 (Canada)	---	
		237272-001 (Canada, OCR)			J80631001x2 +220681001x2	237273-001 (Canada, OCR)		
		J03238-001 (Greece)						

Machine Model		Overlock (B5**, V**)						
Ref. No.	Sub-Class	Single Phase				Three Phase		
		Voltage (V)	110	220 ~ 240	240 Australia	230 CE	220	380 ~ 415
A-18	INV Motor Assembly	J80643-002				J80652-002		
A-19	Taper Pulley Q105	J02281-001						
C-6	Power Circuit Unit	J80634-001	J80635-001	J80636-001		J80637-001	J80690-001	J80691-001
C-16	Control Circuit Unit	J80852-001						
F-1~ F-43	Switch Assembly	229240-001	J01244-001	236127-001 (Australia)	J03134-001 (3P Plug A.)	229250-001		J80727-001 (EMC BOX) + J02678-001 +220681-001 + J80631-001 (EMC CORE)
		J02045-001 (USA)	J02046-001 (OCR)		J80783001+	J02047-001 (USA)	J03245-001 (OCR)	
		230542-001 (Canada)	236127-001 (New Zealand)		J02679001+	230545-001 (Canada)	---	
		237272-001 (Canada, OCR)			J80631001x2 +220681001x2	237273-001 (Canada, OCR)		
		J03238-001 (Greece)						

Machine Model		C51 , P73 , P81						
Ref. No.	Sub-Class	Single Phase				Three Phase		
		Voltage (V)	110	220 ~ 240	240 Australia	230 CE	220	380 ~ 415
A-18	INV Motor Assembly	J80643-001				J80652-001		
A-19	Taper Pulley Q90	J02278-001						
C-6	Power Circuit Unit	J80634-001	J80635-001	J80636-001		J80637-001	J80690-001	J80691-001
C-16	Control Circuit Unit	J80852-001						
F-1~ F-43	Switch Assembly	229240-001	J01244-001	236127-001 (Australia)	J03134-001 (3P Plug A.)	229250-001		J80727-001 (EMC BOX) + J02678-001 +220681-001 + J80631-001 (EMC CORE)
		J02045-001 (USA)	J02046-001 (OCR)		J80783001+	J02047-001 (USA)	J03245-001 (OCR)	
		230542-001 (Canada)	236127-001 (New Zealand)		J02679001+	230545-001 (Canada)	---	
		237272-001 (Canada, OCR)			J80631001x2 +220681001x2	237273-001 (Canada, OCR)		
		J03238-001 (Greece)						

Machine Model		B883						
Ref. No.	Sub-Class	Single Phase				Three Phase		
		Voltage (V)	110	220 ~ 240	240 Australia	230 CE	220	380 ~ 415
A-18	INV Motor Assembly	J80643-001				J80652-001		
A-19	Taper Pulley Q90	J02278-001						
C-6	Power Circuit Unit	J80634-001	J80635-001	J80636-001		J80637-001	J80690-001	J80691-001
C-16	Control Circuit Unit	J80852-001						
F-1~ F-43	Switch Assembly	J00452-001	J00460-001	J00464-001 (Australia)	J03313-001 (3P Plug A.)	J00470-001		J80727-001 (EMC BOX) +
		J00453-001 (USA)	J00462-001 (OCR)		J80783001+	J02432-001 (USA)	J03246-001 (OCR)	
		J00455-001 (Canada)	J00464-001 (New Zealand)		J02679001+	J00473-001 (Canada)		J02678-001 +220681-001 +
		J00457-001 (Canada, OCR)			J80631001x2 +220681001x2	J00477-001 (Canada, OCR)		
				J03247-001 (Greece)				

Machine Model		B722 , B724						
Ref. No.	Sub-Class	Single Phase				Three Phase		
		Voltage (V)	110	220 ~ 240	240 Australia	230 CE	220	380 ~ 415
A-18	INV Motor Assembly	J80643-001				J80652-001		
A-19	Taper Pulley Q90	J02278-001						
C-6	Power Circuit Unit	J80634-001	J80635-001	J80636-001		J80637-001	J80690-001	J80691-001
C-16	Control Circuit Unit	J80852-001						
F-1~ F-43	Switch Assembly	229240-001	J01244-001	236127-001 (Australia)	J03134-001 (3P Plug A.)	229250-001		J80727-001 (EMC BOX) +
		J02045-001 (USA)	J02046-001 (OCR)		J80783001+	J02047-001 (USA)	J03245-001 (OCR)	
		230542-001 (Canada)	236127-001 (New Zealand)		J02679001+	230545-001 (Canada)		J02678-001 +220681-001 +
		237272-001 (Canada, OCR)			J80631001x2 +220681001x2	237273-001 (Canada, OCR)		
				J03238-001 (Greece)				

Machine Model		B877 , B878						
Ref. No.	Sub-Class	Single Phase				Three Phase		
		Voltage (V)	110	220 ~ 240	240 Australia	230 CE	220	380 ~ 415
A-18	INV Motor Assembly	J80643-001				J80652-001		
A-19	Taper Pulley Q90	J02278-001						
C-6	Power Circuit Unit	J80634-001	J80722-001	J80724-001		J80723-001	J80690-001	J80691-001
C-16	Control Circuit Unit	J80852-001						
F-1~ F-43	Switch Assembly	229240-001	J01244-001	236127-001 (Australia)	J03134-001 (3P Plug A.)	229250-001		J80727-001 (EMC BOX) +
		J02045-001 (USA)	J02046-001 (OCR)		J80783001+	J02047-001 (USA)	J03245-001 (OCR)	
		230542-001 (Canada)	236127-001 (New Zealand)		J02679001+	230545-001 (Canada)		J02678-001 +220681-001 +
		237272-001 (Canada, OCR)			J80631001x2 +220681001x2	237273-001 (Canada, OCR)		
				J03238-001 (Greece)				

Machine Model		B256/7 , B276/7							
Ref. No.	Sub-Class	Single Phase				Three Phase			
		Voltage (V)	110	220 ~ 240	240 Australia	230 CE	220	380 ~ 415	400 CE
A-18	INV Motor Assembly	J80644-002				J80653-002			
A-19	Taper Pulley Q105	J02281-001							
C-6	Power Circuit Unit	J80634-001	J80722-001	J80724-001		J80723-001	J80690-001	J80691-001	
C-16	Control Circuit Unit	J80674-001							
C-17	Sub Control Circuit Unit	J80675-001							
F-1~ F-43	Switch Assembly	229240-001	J01244-001	236127-001 (Australia)	J03134-001 (3P Plug A.)	229250-001		J80727-001 (EMC BOX) + J02678-001 +220681-001 + J80631-001 (EMC CORE)	
		J03239-001 (USA)	J03392-001 (OCR)			J03240-001 (USA)	J03245-001 (OCR)		
		230542-001 (Canada)	236127-001 (New Zealand)		---	230545-001 (Canada)			
		J03241-001 (Canada, OCR)	J03393-001 (Canada, OCR)		J03238-001 (Greece)	J03242-001 (Canada, OCR)	---		

Machine Model		B776							
Ref. No.	Sub-Class	Single Phase				Three Phase			
		Voltage (V)	110	220 ~ 240	240 Australia	230 CE	220	380 ~ 415	400 CE
A-18	INV Motor Assembly	J80643-001				J80652-001			
A-19	Taper Pulley Q90	J02278-001							
C-6	Power Circuit Unit	J80634-001	J80722-001	J80724-001		J80723-001	J80690-001	J80691-001	
C-16	Control Circuit Unit	J80762-001							
C-17	Sub Control Circuit Unit	J80764-001							
F-1~ F-43	Switch Assembly	229240-001	J01244-001	236127-001 (Australia)	J03134-001 (3P Plug A.)	229250-001		J80727-001 (EMC BOX) + J02678-001 +220681-001 + J80631-001 (EMC CORE)	
		J02045-001 (USA)	J02046-001 (OCR)			J02047-001 (USA)	J03245-001 (OCR)		
		230542-001 (Canada)	236127-001 (New Zealand)		J02679001+ J02679001+ J80631001x2 +220681001x2	230545-001 (Canada)			
		237272-001 (Canada, OCR)			J03238-001 (Greece)	237273-001 (Canada, OCR)	---		

Machine Model		B891							
Ref. No.	Sub-Class	Single Phase				Three Phase			
		Voltage (V)	110	220 ~ 240	240 Australia	230 CE	220	380 ~ 415	400 CE
A-18	INV Motor Assembly	J80644-001				J80653-001			
A-19	Taper Pulley Q80	J02276-001							
C-6	Power Circuit Unit	J80842-001	J80843-001	J80844-001		J80845-001	J80690-001	J80691-001	
C-16	Control Circuit Unit	J80779-001							
C-17	Sub Control Circuit Unit	J80781-001							
F-1~ F-43	Switch Assembly	229240-001	J01244-001	236127-001 (Australia)	J03134-001 (3P Plug A.)	229250-001		J80727-001 (EMC BOX) + J02678-001 +220681-001 + J80631-001 (EMC CORE)	
		J03239-001 (USA)	J03392-001 (OCR)			J03240-001 (USA)	J03245-001 (OCR)		
		230542-001 (Canada)	236127-001 (New Zealand)		---	230545-001 (Canada)			
		J03241-001 (Canada, OCR)	J03393-001 (Canada, OCR)		J03238-001 (Greece)	J03242-001 (Canada, OCR)	---		

INDEX / VERZEICHNIS /  
INDEX / INDICE

PARTS NO.	REF. NO.	PARTS NO.	REF. NO.	PARTS NO.	REF. NO.
002400-806	D-18	225534-001	i-11-21	291674-011	G-1
014500-632	A-2	228260-001	D-28-1-8, D-28-2-8	388706-011	G-1
021080-206	D-10	228272-001	F-16-1-1	J00021-001	i-11-24
021080-302	i-10-6, i-11-6	228295-001	C-5, C-20	J00074-001	C-31, i-11-36
021100-206	D-4	228475-000	i-11-35	J00107-001	D-2
021400-205	E-26-2	228957-001	i-11-25	J00351-001	B-8
021400-303	J-7	229017-001	C-8-1, C-12, C-18, C-25, D-14-3, D-28-1-7, D-28-2-7, J-6	J00353-001	D-29
021400-305	i-11-26		J00452-001	F-22	
025030-132	H-18		J00453-001	F-24	
025040-173	D-8-3	229240-001	F-1	J00455-001	F-23
025040-335	i-11-23	229250-001	F-12	J00457-001	F-25
025080-336	D-11	230542-001	F-2	J00460-001	F-26
025100-236	D-5	230545-001	F-13	J00461-001	F-37-1
025680-232	E-32	233063-001	H-19	J00462-001	F-28
026350-132	H-15	233067-001	H-12	J00464-001	F-27
028030-242	H-17	233091-002	H-10	J00470-001	F-30
028040-245	D-8-2	233092-001	H-11	J00473-001	F-31
028080-242	i-10-5, i-11-5	233217-002	i-10-1	J00477-001	F-33
028080-246	D-12	233221-003	i-10-2, i-11-2	J00494-001	B-2, C-7-1, C-8-2
028100-246	A-21, D-6	233222-003	i-10-3, i-11-3	J00649-001	D-28-1-5, D-28-2-5
028350-242	H-14	233223-001	i-10-4, i-11-4	J00715-001	A-12-2
037401-015	D-28-1-3, D-28-2-3	233224-002	i-10-7, i-11-7	J01084-001	i-11-27
061400-402	i-10-17, i-11-19	233228-001	i-10-12	J01089-001	i-11-34
061401-205	i-10-9, i-10-19, i-11-9, i-11-28	233229-001	i-10-13, i-11-13	J01244-001	F-5, F-9-1
		233230-001	i-10-14, i-11-14	J01251-001	J-2
062301-402	H-16	233231-001	i-10-8, i-11-8	J01252-001	J-3-1
062401-063	D-8-4	233232-001	i-10-11, i-11-11	J01253-001	J-3-2
062401-605	E-26-1	233233-001	i-10-10, i-11-10	J01370-001	C-30
062402-005	i-11-22	233236-001	i-10-23, i-11-33	J01463-001	C-29
062670-612	H-21	233250-001	i-10-21, i-11-31	J01473-001	J-4
062670-812	H-40	233251-003	i-10-22	J01585-001	i-10-25
062671-212	E-7	233263-001	G-1-2	J01778-001	C-16-1
062672-012	H-13	233268-002	G-1-1	J01855-001	i-10-18
062680-812	H-26	233487-002	i-10-24	J01892-001	C-15
062681-212	E-6, G-1-5	233488-002	i-10-24	J01988-001	E-3-1
076202-801	A-12-1, A-12-2	233491-001	i-12	J01989-001	E-2-1
0A4301-205	C-7-2	233500-001	H-20	J01990-001	E-1-1
0A4402-506	C-18	233501-001	G-1-6	J02027-001	D-21
137207-71110	E-1	233515-001	i-14	J02028-001	D-23
137207-71111	E-12	233516-001	i-10-26	J02029-001	C-14
137207-71112	E-27	233544-001	H-25	J02036-001	D-15
137207-71210	E-2	233545-001	H-24	J02037-001	C-26-1
137207-71211	E-13	233573-001	H-33	J02038-001	D-13-1
137207-71212	E-28	233574-001	H-37	J02039-001	D-14-1
137207-71310	E-3	233575-001	H-31	J02045-001	F-3
137207-71311	E-14	233604-001	H-29	J02046-001	F-7
137207-71312	E-29	233618-001	H-34	J02047-001	F-14
137207-81111	E-16	233619-001	G-1-2	J02054-001	E-9
137207-81211	E-17	233694-001	H-39	J02058-001	E-5
137207-81311	E-18	233695-001	H-41	J02059-001	E-8
142268-001	H-30	233696-001	H-38	J02061-001	E-23
151431-001	H-32	236127-001	F-6	J02062-001	C-4, C-10
200190-001	F-36, i-13	236315-001	H-43	J02130-001	D-28-1-4, D-28-2-4
203684-001	A-13-1, A-13-2	237043-002	G-1-4	J02195-001	C-27-1
215081-001	D-17, D-22	237272-001	F-4	J02276-001	A-19
215081-002	E-4, G-1-3	237273-001	F-15	J02278-001	A-19
215082-001	B-10	238186-001	i-11-15	J02281-001	A-19
215082-003	E-25	238188-001	I-10-15, i-11-16	J02293-001	B-7
215822-000	C-30-1	238191-001	i-11-20	J02302-001	F-8-1
216205-000	A-20	238194-001	i-11-1	J02432-001	F-32
217071-001	B-5	238196-001	i-11-32	J02493-001	A-22
217093-001	i-10-16, i-11-18	291640-011	G-1	J02495-001	D-13-2
220681-001	C-3, C-33, F-41	291642-011	G-1	J02496-001	D-14-2
222372-001	D-9	291657-013	G-1	J02497-001	C-22
224508-001	B-4, B-5, E-26-3	291659-011	G-1	J02501-001	D-25



PARTS NO.	REF. NO.	PARTS NO.	REF. NO.	PARTS NO.	REF. NO.
J02501-002	D-25	J03392-001	F-42	S02702-101	H-22
J02502-001	C-2	J03393-001	F-43	S02703-001	H-23
J02503-001	C-2	J03413-001	D-28-1-1	S03816-001	F-35, J-5
J02505-001	C-11	J03417-001	D-28-1-6, D-28-2-6	S14823-001	i-11-12
J02506-001	C-11	J03419-001	D-28-2-1	S38352-101	D-26
J02508-001	B-9	J03555-001	E-31	UF8582-001	D-32
J02513-001	B-1	J03588-001	C-27-2, F-8-2, F-9-2, F-16-1-2	UG4163-000	C-21, D-20
J02514-001	C-4				
J02515-001	B-3	J03593-001	D-28-2-1		
J02516-001	B-6	J80081-040	i-11		
J02517-001	D-7	J80347-001	J-1-1		
J02518-001	A-14	J80380-040	i-10		
J02521-001	A-14	J80630-001	i-10		
J02525-001	A-1	J80631-001	C-28, D-19, E-30, F-18, F-40-1		
J02537-001	A-6				
J02538-001	A-6	J80633-001	E-15-1		
J02560-001	A-17	J80634-001	C-6		
J02563-001	A-16	J80635-001	C-6		
J02566-001	E-10	J80636-001	C-6		
J02567-001	E-11	J80637-001	C-6		
J02568-001	D-24, D-31	J80638-001	D-28-2		
J02628-001	C-13	J80639-001	D-28-1		
J02664-001	C-2	J80640-001	D-28-1-2, D-28-2-2		
J02678-001	F-17	J80643-001	A-18		
J02679-001	F-39	J80643-002	A-18		
J02832-001	D-8-1	J80644-001	A-18		
J02949-001	i-10-18	J80644-002	A-18		
J02950-001	i-10-20, i-11-29	J80652-001	A-18		
J02955-001	D-23	J80652-002	A-18		
J02989-001	A-24	J80653-001	A-18		
J02991-001	A-15	J80653-002	A-18		
J02992-001	A-23	J80654-001	A-10		
J02997-001	A-11	J80654-002	A-10		
J02998-001	C-1, D-1	J80655-001	A-10		
J03033-001	D-16	J80655-002	A-10		
J03039-001	B-11	J80656-001	A-10		
J03040-001	C-19	J80656-002	A-10		
J03041-001	C-20	J80657-001	A-10		
J03044-001	D-23	J80657-002	A-10		
J03045-001	D-25	J80674-001	C-16		
J03053-001	C-22	J80675-001	C-17		
J03122-001	C-30	J80690-001	C-6		
J03123-001	C-2	J80691-001	C-6		
J03124-001	C-2	J80722-001	C-6		
J03125-001	C-9	J80723-001	C-6		
J03127-001	C-2	J80724-001	C-6		
J03134-001	F-8, F-38-1	J80727-001	F-16		
J03135-001	F-16-1	J80762-001	C-16		
J03238-001	F-9	J80764-001	C-17		
J03239-001	F-10	J80777-001	J-1-2		
J03240-001	F-20	J80779-001	C-16		
J03241-001	F-11	J80781-001	C-17		
J03242-001	F-21	J80783-001	F-38		
J03245-001	F-19	J80793-001	G-1		
J03246-001	F-34	J80795-001	F-40		
J03247-001	F-29	J80796-001	C-34, F-40-2		
J03260-001	C-22	J80842-001	C-6		
J03275-001	D-3	J80843-001	C-6		
J03278-001	E-24	J80844-001	C-6		
J03288-001	C-13	J80845-001	C-6		
J03313-001	F-37	J80852-001	C-16		
J03314-001	A-8	J80857-001	D-28-2		
J03316-001	D-30	J80859-001	J-1-3		
J03333-001	A-7-1	J80899-001	E-15-2		
J03365-001	C-32	S02701-001	H-27		

DATE	DESCRIPTION	AMOUNT	CHECK NO.	BANK	INITIALS
10/1/00	DEPOSIT	100.00			
10/2/00	PAYROLL	50.00	101		
10/3/00	RENT	25.00	102		
10/4/00	UTILITIES	15.00	103		
10/5/00	SALES	75.00			
10/6/00	EXPENSES	30.00	104		
10/7/00	INCOME TAX	10.00	105		
10/8/00	SALES	80.00			
10/9/00	RENT	25.00	106		
10/10/00	PAYROLL	50.00	107		
10/11/00	UTILITIES	15.00	108		
10/12/00	SALES	90.00			
10/13/00	EXPENSES	35.00	109		
10/14/00	INCOME TAX	10.00	110		
10/15/00	SALES	100.00			
10/16/00	RENT	25.00	111		
10/17/00	PAYROLL	50.00	112		
10/18/00	UTILITIES	15.00	113		
10/19/00	SALES	110.00			
10/20/00	EXPENSES	40.00	114		
10/21/00	INCOME TAX	10.00	115		
10/22/00	SALES	120.00			
10/23/00	RENT	25.00	116		
10/24/00	PAYROLL	50.00	117		
10/25/00	UTILITIES	15.00	118		
10/26/00	SALES	130.00			
10/27/00	EXPENSES	45.00	119		
10/28/00	INCOME TAX	10.00	120		
10/29/00	SALES	140.00			
10/30/00	RENT	25.00	121		
10/31/00	PAYROLL	50.00	122		



