

BAS-010A

パーツブック
PARTS BOOK
TEILEKATALOG
LIVRE DES PIECES
LIBRO DE REFERENCIA DE PIEZAS

単環縫ボタン付けミシン ボタンフィーダー装置付

CHAINSTITCH BUTTON SEWER WITH BUTTON FEEDER

AUTOMATISCHE KNOPFZUFUHR PASSEND FÜR
KETTENSTICH-KNOPFANNÄHMASCHINE

DISTRIBUTEUR AUTOMATIQUE DE BOUTONS POUR MACHINE
POSE-BOUTONS - POINT DE CHAINETTE

MAQUINA DE BOTONES CORTAHILOS CON ALIMENTADOR DE BOTONES

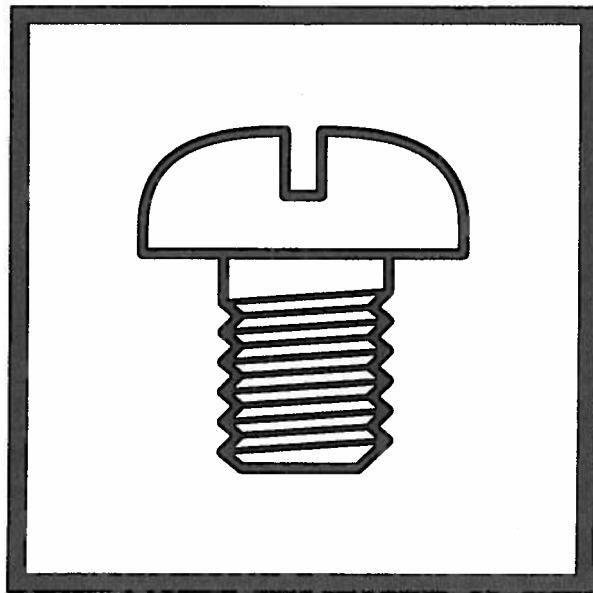

brother®



パーツブックご利用に際して

1. この本は、1995年7月のデータに基づいて作成されたものです。
2. 部品は予告なしに設計変更される場合があります。
3. 組単位で補給する部品は、[] 破線で示しております。

目 次

A. 主体関係	1
B. 針数変換関係	1
C. 駆動・停止関係	3
D. 針棒駆動関係	5
E. 送り関係	7
F. 押エ上ゲ関係	11
G. 下軸関係	13
H. 糸切り関係	13
J. 糸通シ関係	15
K. 糸サバキ関係	17
L. 糸払い関係	17
M. 渡り糸関係	19
N. 起動装置関係	21
P1. ボタンフィーダー関係	23
P2. ボタンフィーダー関係	27
P3. ボタンフィーダー関係	31
Q. フィーダー関係	35
R. コントロールボックス関係	37
S. ボタン検知関係	37
T. 電装品関係	39
U. オプションパーツ	41
Z1. 付属品関係(オプションパーツ)	41
Z2. 付属品関係	43
ゲージパーツリスト	45
警告ラベル	47
索引	49

Notes for using this parts book

1. This book was prepared based on information available in July 1995.
2. Parts are subject to changes in design without prior notice.
3. Parts supplied as complete assemblies are circled by a dotted line [] .

CONTENTS

A. Machine body	1
B. Stitch number conversion	1
C. Driving clutch and brake mechanism	3
D. Needle bar and driving clutch mechanism	5
E. Feed mechanism	7
F. Presser foot lifter mechanism	11
G. Lower shaft mechanism	13
H. Thread trimmer mechanism	13
J. Threading mechanism	15
K. Loop spreading mechanism	17
L. Thread wiper mechanism	17
M. Crossover stitch mechanism	19
N. Starting device mechanism	21
P1. Button feeder mechanism	23
P2. Button feeder mechanism	27
P3. Button feeder mechanism	31
Q. Feeder mechanism	35
R. Control box mechanism	37
S. Button detector mechanism	37
T. Power supply equipment	39
U. Option parts	41
Z1. Accessories (Option parts)	41
Z2. Accessories	43
Gauge parts list	45
Warning labels	47
INDEX	49

Hinweise zur Verwendung dieser Teileliste

1. Dieses Buch basiert auf den Informationen vom Juli 1995.
2. Modelländerungen sind vorbehalten.
3. Die Teile, die als kompletter Satz geliefert werden, sind mit einer gestrichelten Linie umrandet.

INHALTSVERZEICHNIS

A. Maschinengehäuse	1
B. Stichtzahlumrechnung	1
C. Antriebskupplung Und Stoppmechanismus	3
D. Nadelstange und antriebskupplung	5
E. Transportvorrichtung	7
F. Stoffhalterhebervorrichtung	11
G. Untere Welle	13
H. Fadenabschneidevorrichtung	13
J. Fadenführungsvorrichtung	15
K. Schleifenzieher	17
L. Fadenwischvorrichtung	17
M. Verbindungsstichvorrichtung	19
N. Startvorrichtung	21
P1. Knopfzuführungsvorrichtung	23
P2. Knopfzuführungsvorrichtung	27
P3. Knopfzuführungsvorrichtung	31
Q. Knopfsortierer	35
R. Schaltkasten	37
S. Knopfdetektor	37
T. Stromversorgung	39
U. Sondezubehör	41
Z1. Zubehör (Sondezubehör)	41
Z2. Zubehör	43
Lehrenliste	45
Warnschilder	47
VERZEICHNIS	49

Notes sur l'utilisation de ce manuel de pièces détachées

1. Ce manuel a été fait d'après les renseignements valables au mois de Juillet 1995.
2. Les pièces peuvent être sujettes à des modifications sans préavis.
3. Les pièces fournies en tant qu'assemblages complets sont encadrées avec un trait pointillé [] .

TABLE DES MATIERES

A. Corps de la machine	1
B. Conversion de nombre de points	1
C. Embrayage d'entraînement et mécanisme d'arrêt	3
D. Barre à aiguille et mécanisme d'embrayage d'entraînement	5
E. Mécanisme de l'entraînement	7
F. Mécanisme de leueur du pinceur	11
G. Mécanisme de l'arbre inférieur	13
H. Mécanisme de coupe-fil	13
J. Mécanisme de l'enfilage	15
K. Etirement de boucle	17
L. Mécanisme de tire-fil	17
M. Mécanisme de point zigzag double	19
N. Mécanisme de dispositif de démarrage	21
P1. Alimentation pour boutons	23
P2. Alimentation pour boutons	27
P3. Alimentation pour boutons	31
Q. Tricur de boutons	35
R. Mécanisme du boîtier de contrôle	37
S. Détecteur de bouton	37
T. Mécanisme de léquipement en alimentation électrique	39
U. Pièces en option	41
Z1. Accessoires (Pièces en option)	41
Z2. Accessoires	43
Liste des pieces d'ecartement	45
Etiquettes d'avertissement	47
INDEX	49

Notas para usar este Manual de Piezas

1. Este libro ha sido compilado basándose en los datos de que se disponía en julio 1995.
2. Las piezas quedan sujetas a cambios de diseño sin aviso previo.
3. Las piezas suministradas como conjuntos completos se enmarcan con una línea punteada [-----].

INDICE

A. Cuerpo de la máquina	1
B. Conversión de número de puntadas	1
C. Embrague de mando y mecanismo de detención	3
D. Barra de aguja y mecanismo de embrague de mando ..	5
E. Mecanismo de la alimentación	7
F. Mecanismo del levantador de ménsula de trabajo	11
G. Mecanismo del eje inferior	13
H. Mecanismo de la cortadura de hiros	13
J. Mecanismo del enhebrado	15
K. Ensanche de bucle	17
L. Mecanismo del limpiador de hilo	17
M. Mecanismo de puntade cruzada	19
N. Mecanismo del dispositivo de arranque	21
P1. Botón de alimentación	23
P2. Botón de alimentación	27
P3. Botón de alimentación	31
Q. Mecanismo de botones	35
R. Mecanismo de la caja de contoles	37
S. Detector de botones	37
T. Mecanismo del equipo de alimentación de corriente ..	39
U. Piezas opcionales	41
Z1. Accesorios (Piezas opcionales)	41
Z2. Accesorios	43
Lista de piezas calibradoras	45
Etiquetas de advertencia	47
INDICE	49

A . 主体関係 / Machine body / Maschinengehäuse / Corps de la machine / Cuerpo de la máquina

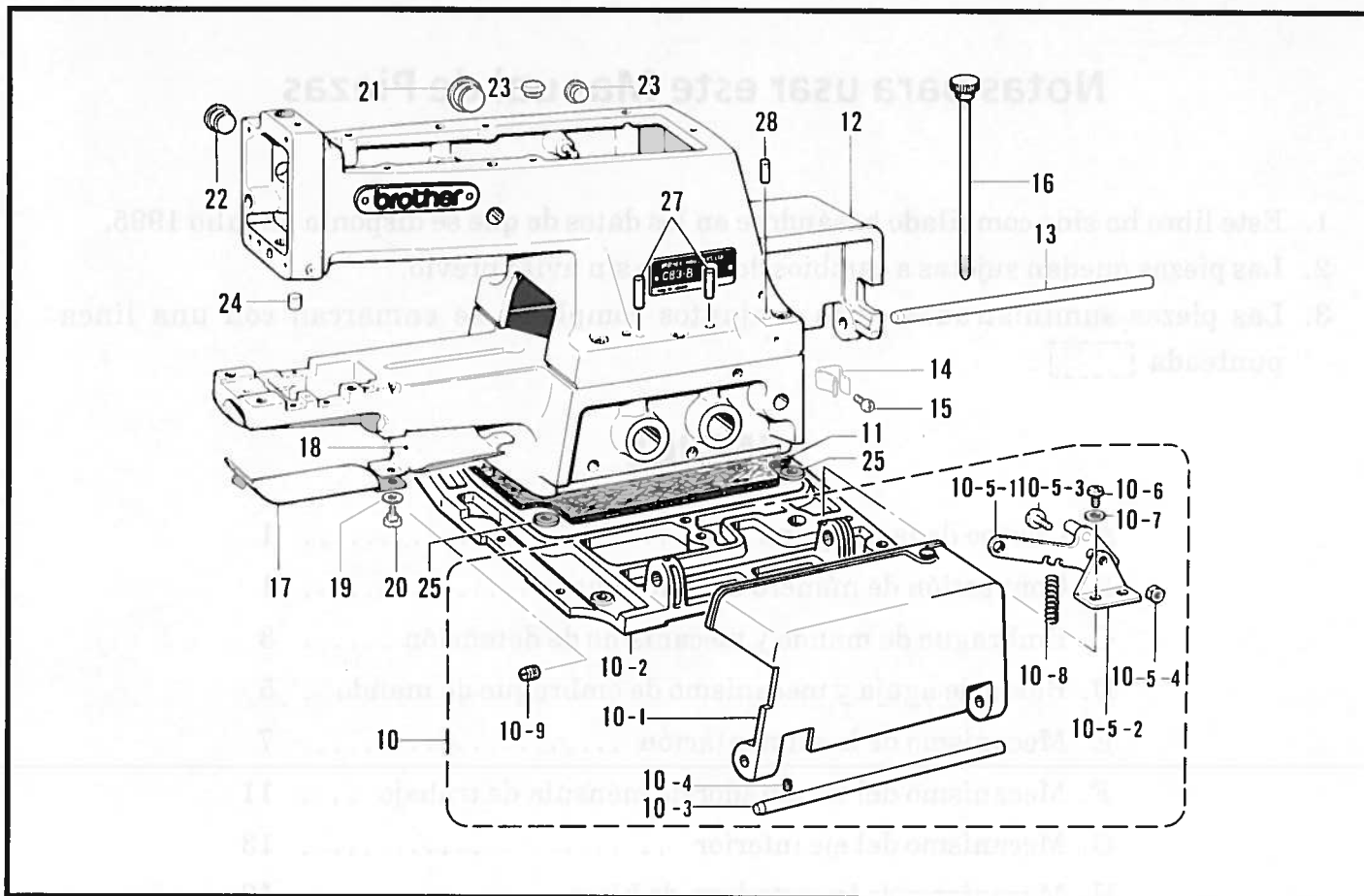

118-917-050

B . 針数変換関係 / Stitch number conversion / Stitchzahlumrechnung /
Conversion de nombre de points / Conversión de número de puntadas

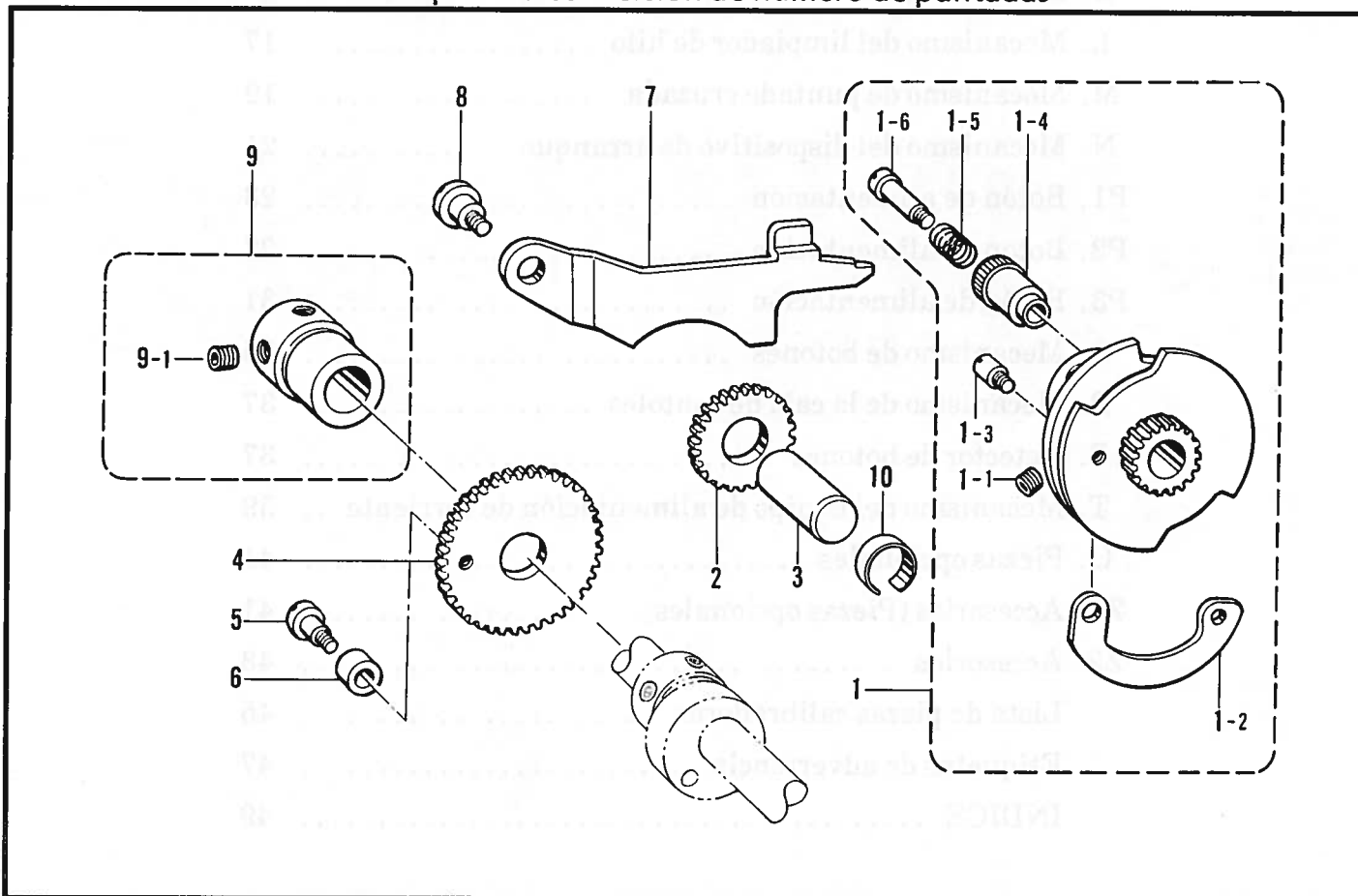

118-917-129

A. 主体関係 / Machine body / Maschinengehäuse / Corps de la machine / Cuerpo de la máquina

REF.NO.	CODE	Q'TY	ヒンメイ	NAME OF PARTS	RM
10	S36592009	1	ベッドダイクミB	BED BASE ASSY (B)	
10-1	S36593000	1	ベッドダイB	BED BASE (B)	
10-2	S05685109	1	ベッドカバーRクミB	BED COVER (R) ASSY (B)	
10-3	114984000	1	ベッドカバージク	BED COVER SHAFT	
10-4	151605002	2	トメネジ5.95	SET SCREW, M5.95	
10-5	S07995001	1	クラッチレバークミ	CLUTCH LEVER ASSY	
10-5-1	142307001	1	クラッチサドウレバークミ	CLUTCH DRIVING LEVER ASSY	
10-5-2	115025001	1	クラッチサドウレバーダイ	CLUTCH DRIVING LEVER PLATE	
10-5-3	115268002	1	シメネジ5.56	SCREW, M5.56	
10-5-4	021750112	1	1シユナツト556-32	NUT, 1 M556-32	
10-6	062711212	2	ナベコ476-32X12	SCREW, PAN M4.76-32X12	
10-7	025710232	2	ヒラザガネチユウ4.76	WASHER, PLAIN M 4.76	
10-8	S36816001	1	クラッチサドウレバーバネ	SPRING	
11	S06713000	1	ベッドダイフェルト	BED BASE FELT	
12	S03374109	1	ベッドカバーLクミ	BED COVER (L) ASSY	
13	114984000	1	ベッドカバージク	BED COVER SHAFT	
14	114985001	2	ベッドカバートメバネ	SPRING, PLATE	
15	062680512	2	ナベコ437-40X5	SCREW, PAN M4.37-40X5	
16	114986101	1	アームベッドコティボルト	BOLT	
17	115275001	1	ルーハカバー	LOOPER COVER	
18	S03376001	1	ベッドツツカバー	COVER	
19	105329001	1	ザガネ	WASHER	
20	114988001	1	ダンネジ4.37	SHOULDER SCREW, M4.37	
21	108520009	1	メクラセン	OIL CAP	
22	117934009	1	メクラセン	OIL CAP	
23	117936009	2	メクラセン	OIL CAP	
24	110104000	1	メクラセン	OIL CAP	
25	158449001	2	ザガネ	WASHER	
27	106436001	4	フェルト (L=30)	FELT (L=30)	
28	147691000	2	フェルト (L=18)	FELT (L=18)	

118-917-050

B. 針数変換関係 / Stitch number conversion / Stizhzahlumrechnung /
Conversion de nombre de points / Conversión de número de puntadas

REF.NO.	CODE	Q'TY	ヒンメイ	NAME OF PARTS	RM
<6, 12, 24針用 / FOR 6, 12, 24 STITCHES>					
1	S36696001	1	ハリカズヘンカンカムクミ16	STITCH CONTROL CAM ASSY (16)	
<8, 16, 32針用 / FOR 8, 16, 32 STITCHES>					
1	S36697001	1	ハリカズヘンカンカムクミ12	STITCH CONTROL CAM ASSY (12)	
1-1	014821022	2	アナトメネジ7.94クボミ	SET SCREW, SOCKET (CP) M7.94	
1-2	S03433001	1	ハリカズカムヘン	STITCH CONTROL CAM SEGMENT	
1-3	115113001	1	ピンネジ4.37	SCREW, M4.37	
1-4	115114001	1	ハリカズヘンカンツマミ	STITCH CONTROL KNOB	
1-5	115115001	1	オシバネ	SPRING, COMPRESSION	
1-6	115116001	1	ダンネジ4.37	SHOULDER SCREW, M4.37	
2	S03436001	1	ハリカズヘンカンMギヤ	STITCH CHANGING (M) GEAR	
3	115118001	1	ヘンカンMギヤジク	STITCH CHANGING (M) GEAR STUD	
4	S03437001	1	ハリカズヘンカンギヤ	STITCH CHANGING GEAR	
5	S03438001	1	ダンネジ4.37	SHOULDER SCREW, M4.37	
6	S03439001	1	コロ7.94	ROLLER 7.94	
7	S03440001	1	32シンレバー	STITCH 32 LEVER	
8	S03441001	1	ダンネジ4.76	SHOULDER SCREW, M4.76	
9	S03442001	1	セツトカラークミ	SET SCREW COLLAR ASSY	
9-1	014770622	2	アナトメネジ6.35クボミ	SET SCREW, SOCKET (CP) M6.35	
10	S05724001	1	トメワ	RETAINING RING	

118-917-129

C. 駆動・停止関係 / Driving clutch and brake mechanism / Antriebskupplung Und Stoppmechanismus / Embrayage d'entraînement et mécanisme d'arrêt / Embrague de mando y mecanismo de detención

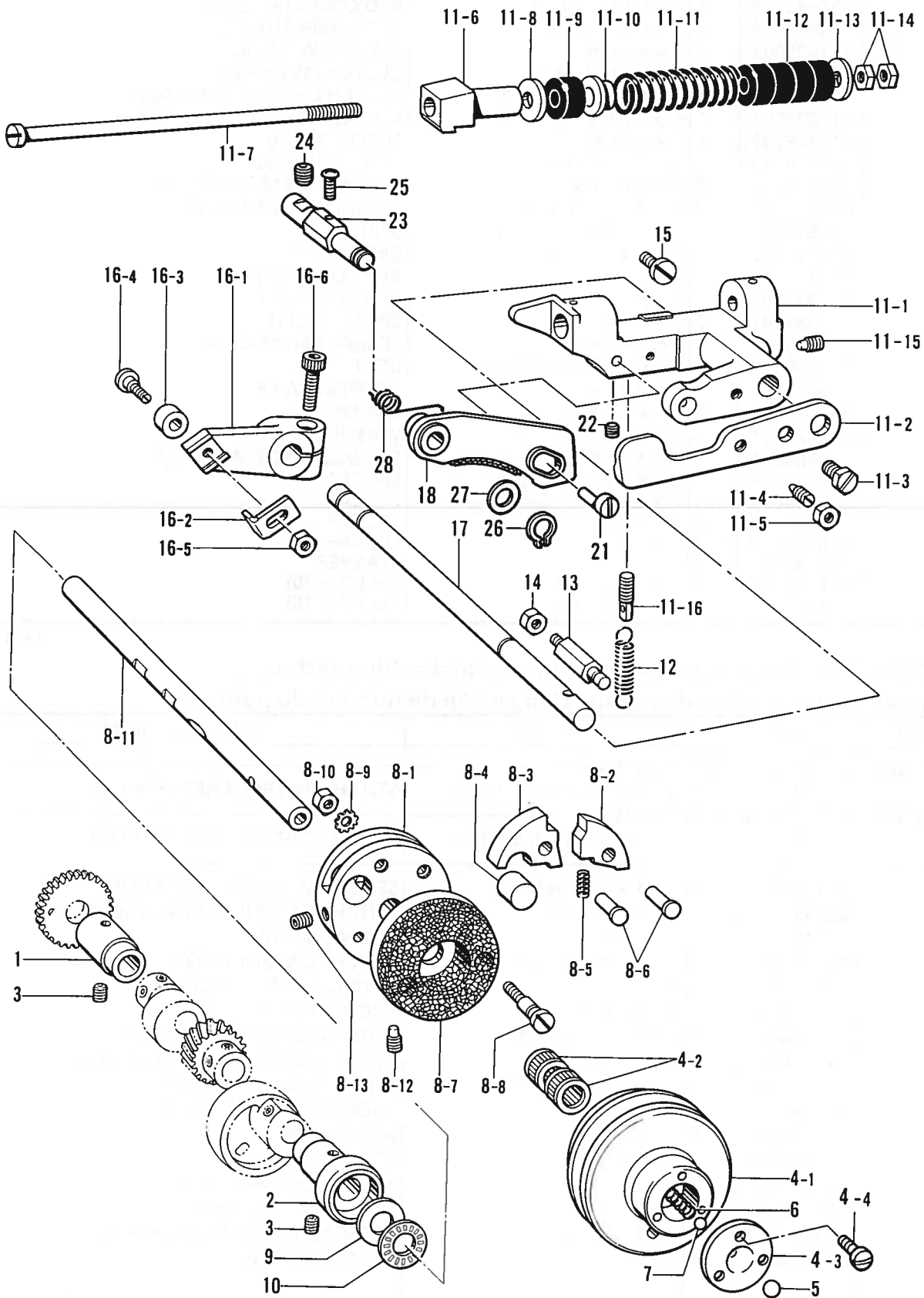

C. 駆動・停止関係 / Driving clutch and brake mechanism / Antriebskupplung Und
 Stopppmechanismus / Embrayage d'entraînement et mécanisme d'arrêt /
 Embrague de mando y mecanismo de detención

REF.NO.	CODE	Q'TY	ヒンメイ	NAME OF PARTS	RM
1	115215100	1	クドウジクメタルL	DRIVING SHAFT BUSH (L)	
2	S03378000	1	クドウジクメタルR	DRIVING SHAFT BUSH (R)	
3	013760712	2	トメネジ5.95クボミ	SET SCREW, (CP) M5.95	
4	S03379101	1	プーリークミ	PULLEY ASSY	
4-1	S34341001	1	プーリ	PULLEY	
4-2	114992000	2	ニードルヘアリング	NEEDLE BEARING	
4-3	S34340001	1	ボールウケ	BALL HOLDER	
4-4	112751003	3	シメネジ3.57	SCREW, M3.57	
5	071079450	1	コウキユウ5/16	BEARING BALL 5/16	
6	114997001	1	プーリモドシオシバネ	SPRING	
7	071055650	1	コウキユウ7/32	BEARING BALL 7/32	
8	S03381101	1	ストツフカムクミ	STOP CAM ASSY	
8-1	S03382101	1	ストツフカム	STOP CAM	
8-2	S03383001	1	セイドウカムヘン	BRAKE CAM SEGMENT	
8-3	S03384001	1	ストツフカムヘン	STOP CAM SEGMENT	
8-4	S03385000	1	カンシヨウゴム	CUSHION RUBBER	
8-5	S03386001	1	ストツフカムバネ	SPRING	
8-6	115004001	2	カムヘンジク	CAM SEGMENT STUD	
8-7	S03387001	1	クラツチイタ	CLUTCH PLATE	
8-8	S05725001	2	シメネジ5.56	SCREW, M5.56	
8-9	115000000	2	ハツキザガネ	TOOTHED WASHER	
8-10	021750112	2	1シユナツト556-32	NUT, 1 M556-32	
8-11	S03388001	1	クドウジク	DRIVING SHAFT	
8-12	149996001	1	ストツフカムセツトネジ	STOP CAM SET SCREW	
8-13	014821022	1	アナトメネジ7.94クボミ	SET SCREW, SOCKET (CP) M7.94	
9	S10668001	1	ザガネ	WASHER	
10	115008000	1	タマジクウケ	BALL BEARING	
11	S36615001	1	クラツチタイクミ	CLUTCH BODY ASSY	
11-1	S36616001	1	クラツチタイ	CLUTCH BODY	
11-2	S03392001	1	ボールオサエイタ	BALL PRESSER PLATE	
11-3	115011201	1	ボルト6.35	BOLT, M6.35	
11-4	115012002	1	トメネジ6.35	SET SCREW, M6.35	
11-5	150554002	1	ナツト6.35	NUT, M6.35	
11-6	S03393001	1	ストツハタイ	STOPPER BRACKET	
11-7	S03394001	1	ストツハジク	STOPPER SHAFT	
11-8	025800332	1	ヒラザガネダイ7.14	WASHER, PLAIN L 7.14	
11-9	S03395000	1	カンシヨウゴム	CUSHION RUBBER	
11-10	S34806001	1	バネウケ	SPRING HOLDER	
11-11	S36693001	1	クラツチストツハーバネ	CLUTCH STOPPER SPRING	
11-12	115018001	4	カンシヨウゴム	CUSHION RUBBER	
11-13	025800332	1	ヒラザガネダイ7.14	WASHER, PLAIN L 7.14	
11-14	021800102	2	ナツト1シユ7.14	NUT, 1 M7.14	
11-15	149996001	1	ストツフカムセツトネジ	STOP CAM SET SCREW	
11-16	S03401001	1	バネカケ	SPRING HOOK	
12	S03402001	1	クラツチヒキバネ	SPRING	
13	115022001	1	バネカケ	SPRING HOOK	
14	102571003	1	ナツト4.37	NUT, M4.37	
15	S03403001	1	ストツハーネジ	STOPPER SCREW	
16	S36694001	1	セイギヨレバークミ	REGULATING LEVER ASSY	
16-1	S03405101	1	ハリカズセイギヨレバー	STITCH CONTROL LEVER	
16-2	S36695001	1	ツメ	CLAW	
16-3	S03407001	1	コロ	ROLLER	
16-4	S03408001	1	コロダンネジ	SHOULDER SCREW	
16-5	110161004	1	ナツト4.76	NUT, M4.76	
16-6	018062022	1	アナボルト6X20	BOLT, SOCKET M6X20	
17	S35727001	1	クラツチタイジク	CLUTCH BODY SHAFT	
18	S37362001	1	ブレーキレバークミ	BRAKE LEVER ASSY	
21	S36642001	1	ブレーキレバークミ	BRAKE LEVER SHAFT	
22	014710522	1	アナトメネジ4.76クボミ	SET SCREW, SOCKET (CP) M4.76	
23	S37133001	1	ブレーキシャフト	BRAKE SHAFT	
24	014760622	1	アナトメネジ5.95	SET SCREW, SOCKET (CP) M5.95	
25	S20740101	1	シメネジ4X10シール	SCREW, SEAL M4X10	
26	048080142	1	トメワジクヨウC8	RETAINING RING, C8	
27	153596001	1	ザガネ	WASHER	
28	S36700001	1	ブレーキレバーバネ	SPRING	

D. 針棒驅動關係 / Needle bar and driving clutch mechanism / Nadelstange und antriebskupplung / Barre à aiguille et mécanisme d'embrayage d'entraînement / Barra de aguja y mecanismo de embrague de mando

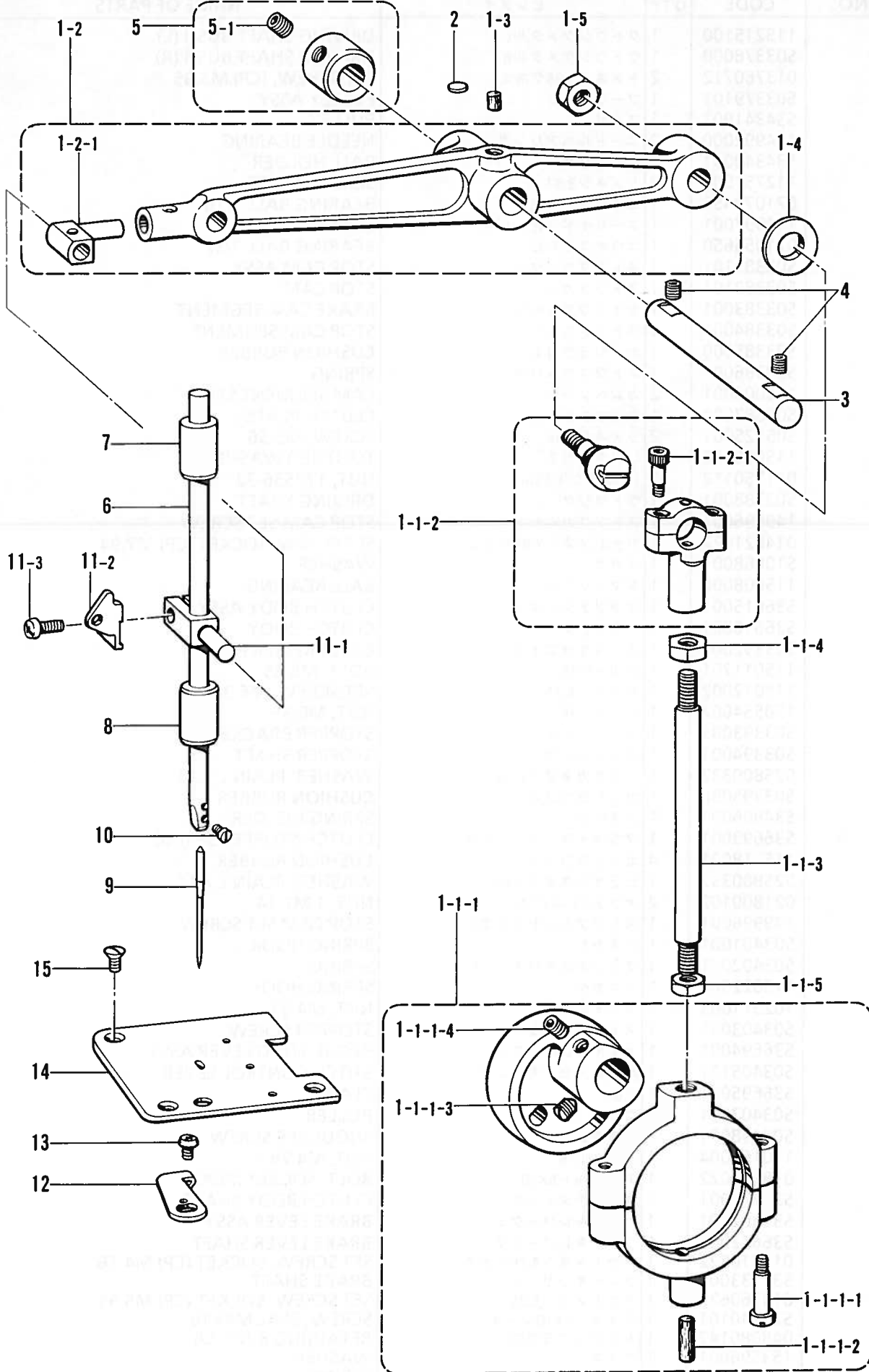

D. 針棒駆動関係 / Needle bar and driving clutch mechanism / Nadelstange und antriebskupplung / Barre à aiguille et mécanisme d'embrayage d'entraînement / Barra de aguja y mecanismo de embrague de mando

REF.NO.	CODE	Q'TY	ヒンメイ	NAME OF PARTS	RM
1	S03409001	1	ハリボウウドウクミ	NEEDLE BAR DRIVING ASSY	
1-1	S03410001	1	クランクロッドクミ	CRANK ROD ASSY	
1-1-1	S03719001	1	クランクロッドLタンブクミ	LOWER CRANK ROD (L) ASSY	
1-1-1-1	142658001	2	シメネジ4.37	SCREW, M4.37	
1-1-1-2	S03412000	1	クランクロッドフェルト	FELT	
1-1-1-3	015770812	1	トメネジ6.35トガリ	SET SCREW, SOCKET (CN) M6.35	
1-1-1-4	014770622	1	アナトメネジ6.35クボミ	SET SCREW, SOCKET (CP) M6.35	
1-1-2	S03720001	1	クランクロッドSタンブクミ	UPPER CRANK ROD (S) ASSY	
1-1-2-1	148425002	2	アナボルト4.37X14	BOLT 4.37X14	
1-1-3	S03414001	1	ロッド	CRANK ROD	
1-1-4	021800102	1	ナット1シユ7.14	NUT, 1 M7.14	
1-1-5	115042001	1	ナット7.14	NUT 7.14	
1-2	S03415001	1	ハリボウウドウレバークミ	NEEDLE BAR DRIVING LEVER ASSY	
1-2-1	115048101	1	ハリボウダキツギテ	NEEDLE BAR BRACKET	
1-3	S03417000	1	クドウレバーフエルト	FELT	
1-4	S03418000	1	フレトメザガネ	WASHER	
1-5	105812003	1	ナット7.94	NUT, M7.94	
2	S03419001	1	カンザ	WASHER	
3	S03420001	1	クドウレバークミ	NEEDLE BAR DRIVING LEVER SHAFT	
4	014760622	2	アナトメネジ5.95	SET SCREW, SOCKET (CP) M5.95	
5	S03421001	1	セツトカラークミ	SET SCREW COLLAR ASSY	
5-1	014770622	2	アナトメネジ6.35クボミ	SET SCREW, SOCKET (CP) M6.35	
6	S06137001	1	ハリボウ	NEEDLE BAR	
7	S03424000	1	ハリボウメタルU	NEEDLE BAR BUSH (U)	
8	S03425000	1	ハリボウメタルD	NEEDLE BAR BUSH (D)	
9	115053016	1	ミシンハリTQX1(#16)	NEEDLE TQX1 (#16)	
10	140553102	1	アタマツキトメネジ3.18	SET SCREW, M3.18	
11	S03426101	1	ハリボウダキクミ	NEEDLE BAR CLAMP ASSY	
11-1	S03427101	1	ハリボウダキ	NEEDLE BAR CLAMP	
11-2	S03428001	1	テンビン	THREAD TAKE-UP	
11-3	062671212	1	ナベコ357-40X12	SCREW, PAN M3.57-40X12	
12	S03429101	1	ハリウケ	NEEDLE GUIDE	
13	062710612	1	ナベコ476-32X6	SCREW, PAN M4.76-32X6	
14	S36622001	1	ハリイタ	NEEDLE PLATE	
15	S01702001	3	マルサラネジ4.37X10	SCREW, OVAL M4.37X10	

E. 送り関係 / Feed mechanism / Transportvorrichtung / Mécanisme de l'entraînement / Mecanismo de la alimentación

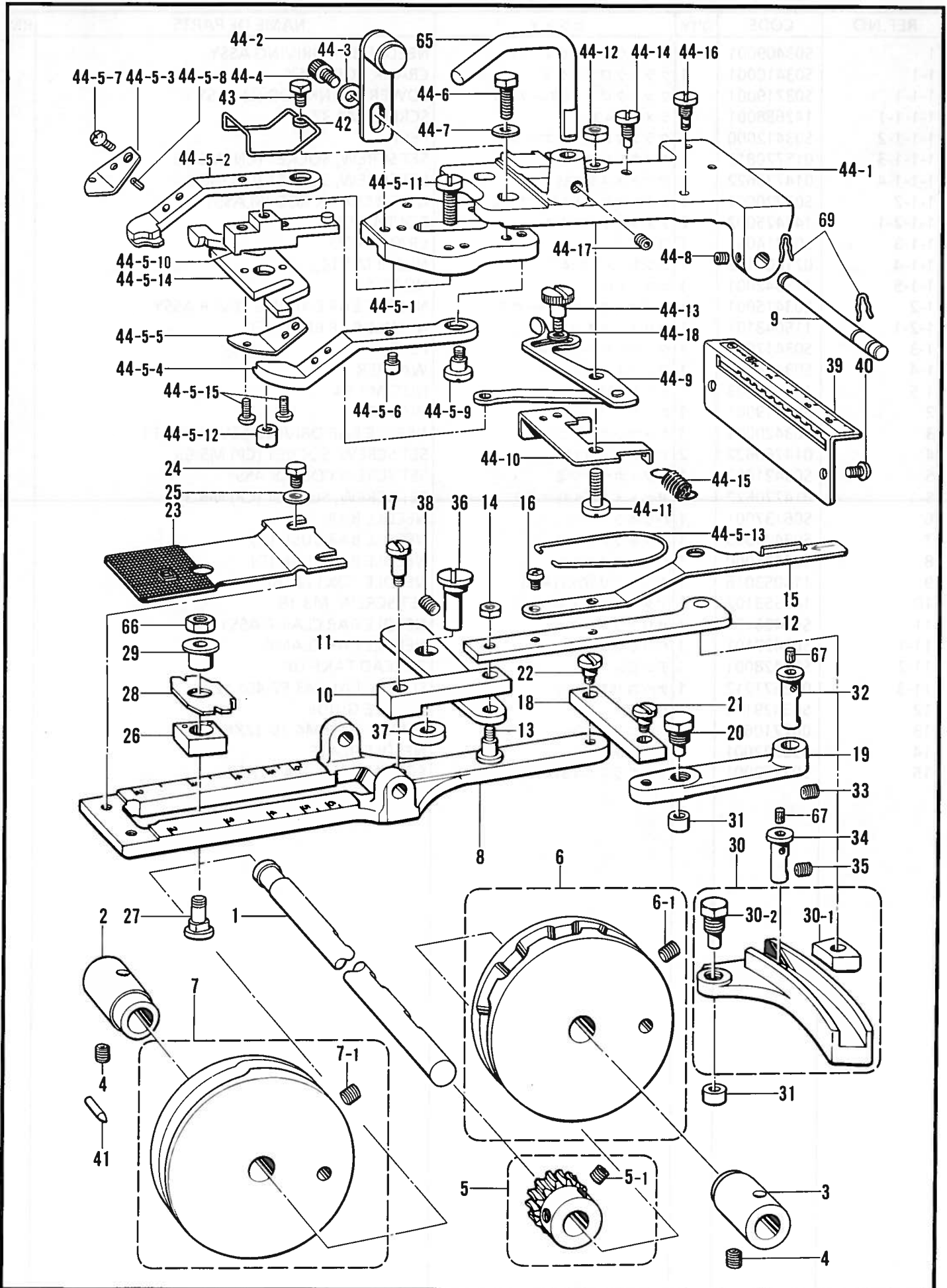

E. 送り関係 / Feed mechanism / Transportvorrichtung / Mécanisme de l'entraînement /
Mecanismo de la alimentación

REF.NO.	CODE	Q'TY	ヒンメイ	NAME OF PARTS	RM
1	115078101	1	カムジク	CAM SHAFT	
2	S03444000	1	カムジクメタルL	CAM SHAFT BUSH (L)	
3	115080000	1	カムジクメタルR	CAM SHAFT BUSH (R)	
4	013760712	2	トメネジ5.95クホミ	SET SCREW, (CP) M5.95	
7	S03451001	1	タテオクリカムクミ	VERTICAL FEED CAM ASSY	
7-1	014770622	2	アナトメネジ6.35クホミ	SET SCREW, SOCKET (CP) M6.35	
8	S36626001	1	オクリダイ	FEED BRACKET	
9	S37444001	1	ボタンツカミホルダージク	HOLDER BAR	
10	S03471001	1	タテオクリリンクA	VERTICAL FEED LINK (A)	
11	S03472001	1	タテオクリリンクB	VERTICAL FEED LINK (B)	
12	S03473001	1	タテオクリレンカンクミ	VERTICAL FEED CONNECT ROD ASSY	
13	S03474001	1	ダンネジ4.76	SHOULDER SCREW, M4.76	
14	021710102	1	ナツト1シユ4.76	NUT, 1 M4.76	
15	115105001	1	タテオクリチヨウセツレバー	VERTICAL FEED ADJUST LEVER	
16	062680512	2	ナベコ437-40X5	SCREW, PAN M4.37-40X5	
17	115101001	1	ダンネジ4.76	SHOULDER SCREW, M4.76	
18	115094001	1	オクリリンク	FEED LINK	
19	115096000	1	ヨコオクリレバー	TRANSVERSE FEED LEVER	
20	115097001	1	オクリコロジク	ROLLER SHAFT	
21	115095001	1	ダンネジ4.76	SHOULDER SCREW, M4.76	
22	115095001	1	ダンネジ4.76	SHOULDER SCREW, M4.76	
23	S03476101	1	オクリイタA	FEED PLATE (A)	
24	146360002	2	ボルト4.76X7	BOLT, M4.76X7	
25	S10667001	2	ザガネ	WASHER	
26	S03478101	1	ヨコオクリチヨウセツコマ	TRANSVERSE FEED SLIDE BLOCK	
27	S31724001	1	ヨコオクリチヨウセツネジ	SCREW	
28	S03480001	1	ヨコオクリチヨウセツイタ	TRANSVERSE FEED PLATE	
29	S31723001	1	ヨコオクリチヨウセツジク	ADJUSTING SHAFT	
30	S03482101	1	タテオクリチヨウセツコマクミ	BACK & FORTH FEED SLIDE BLOCK ASSY	
30-1	S03484101	1	タテオクリチヨウセツコマ	BACK & FORTH FEED SLIDE BLOCK	
30-2	115097001	1	オクリコロジク	ROLLER SHAFT	
31	115098001	2	オクリコロ	ROLLER	
32	115099001	1	オクリレバージク	FEED LEVER SHAFT	
33	014760622	1	アナトメネジ5.95	SET SCREW, SOCKET (CP) M5.95	
34	S03485001	1	タテオクリレバージク	VERTICAL FEED LEVER SHAFT	
35	014760622	1	アナトメネジ5.95	SET SCREW, SOCKET (CP) M5.95	
36	S03486001	1	オクリレバージク	FEED LEVER SHAFT	
37	S03611001	1	カラーL	COLLAR (L)	
38	014760622	1	アナトメネジ5.95	SET SCREW, SOCKET (CP) M5.95	
39	115108301	1	タテオクリメモリアイタ	BACK & FORTH FEED LENGTH INDICATOR	
40	062711012	2	ナベコ476-32X10	SCREW, PAN M4.76-32X10	
41	114980001	1	カムイチキメピン	POSITIONING PIN	
42	S37175000	1	フィンガーガード	FINGER GUARD	
43	146360002	1	ボルト4.76X7	BOLT, M4.76X7	
44	S37434009	1	オサエウデクミ917B	PRESSER ARM ASSY 917 (B)	
44-1	S37352009	1	オサエウデ	PRESSER ARM	
44-2	S03459001	1	オサエチヨウセツイタクミ	PRESSER ADJUST PLATE ASSY	
44-3	S03695001	1	ザガネ6	WASHER 6	
44-4	018061022	1	アナボルト6X10	BOLT, SOCKET M6X10	
44-5	S05689001	1	ボタンツカミクミ917B	BUTTON CLAMP ASSY 917(B)	
44-5-1	S03464101	1	ボタンツカミタイ	BUTTON CLAMP BRACKET	
44-5-2	S05679101	1	ボタンツカミL	BUTTON CLAMP (L)	
44-5-3	S05680101	1	ボタンツカミLイタバネ	SPRING, PLATE	
44-5-4	S05678101	1	ボタンツカミR	BUTTON CLAMP (R)	
44-5-5	S05681101	1	ボタンツカミRイタバネ	SPRING, PLATE	
44-5-6	115156001	2	ボタンツカミアンナイピン	PIN	
44-5-7	062680512	2	ナベコ437-40X5	SCREW, PAN M4.37-40X5	
44-5-8	047250642	2	スプリングピンAW2.5	PIN, SPRING ROLL AW2.5	
44-5-9	115158001	2	ダンネジ4.76	SHOULDER SCREW, M4.76	

E. 送り関係 / Feed mechanism / Transportvorrichtung / Mécanisme de l'entraînement / Mecanismo de la alimentación

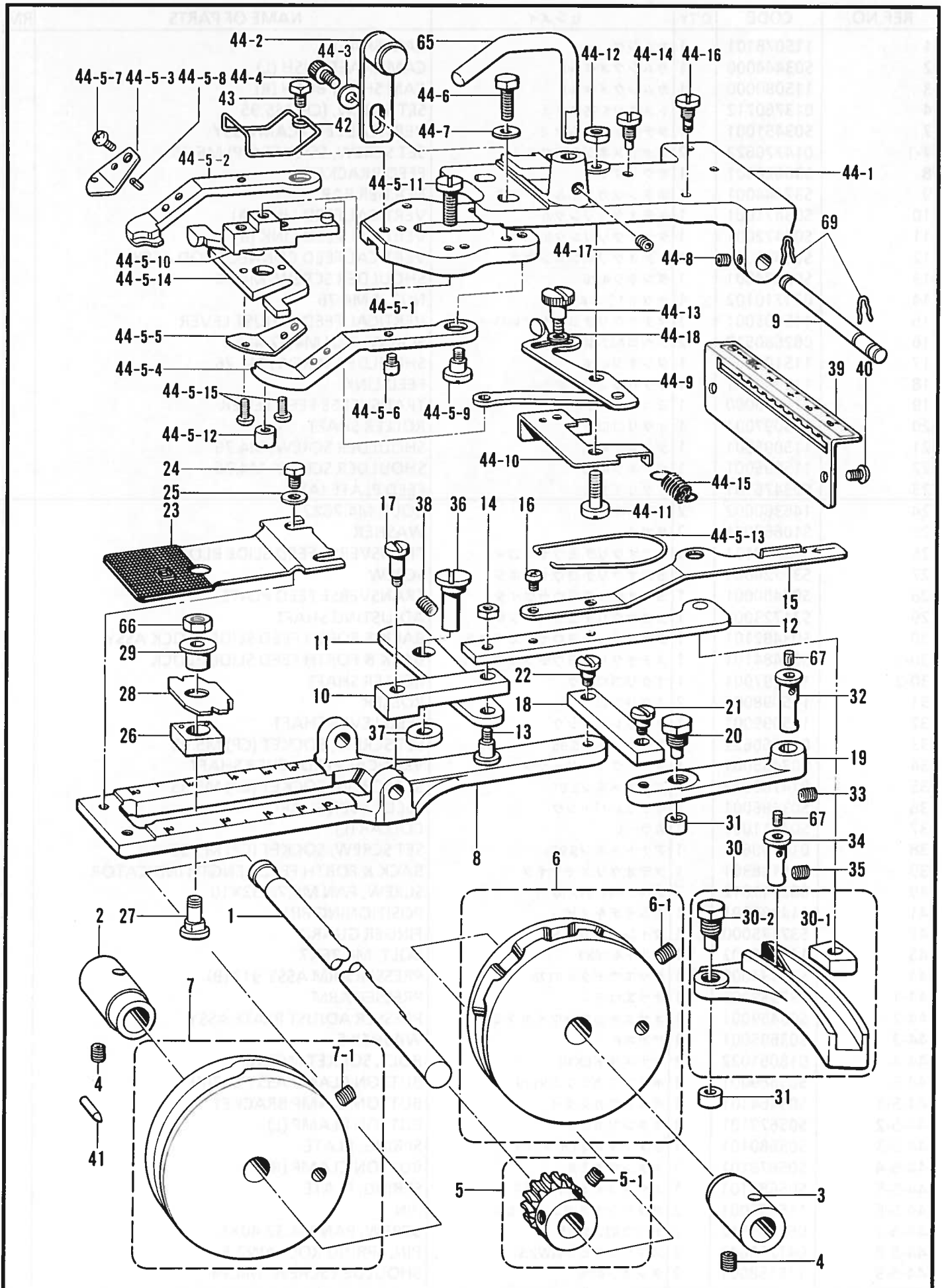

E. 送り関係 / Feed mechanism / Transportvorrichtung / Mécanisme de l'entraînement /
Mecanismo de la alimentación

REF.NO.	CODE	Q'TY	ヒンメイ	NAME OF PARTS	RM
44-5-10	S05687001	1	ボタンツカミMクミB	BUTTON CLAMP (M) ASSY (B)	
44-5-11	S03468001	1	シメネジ4.37	SCREW, M4.37	
44-5-12	S03657001	1	マルナツト4.37	NUT, M4.37	
44-5-13	S03610001	1	ボタンツカミモドシバネ	SPRING	
44-5-14	S05905001	1	ボタンツカミイタカム	BUTTON CLAMP PLATE CAM	
44-5-15	062680812	2	ナベコ437-40X8	SCREW, PAN M4.37-40X8	
44-6	017711412	2	ボルト4.76X14	BOLT, M4.76X14	
44-7	146354001	2	ザガネ	WASHER	
44-8	014680622	2	アナトメネジ4.37クボミ	SET SCREW, SOCKET (CP) M4.37	
44-9	S03600001	1	サイズチヨウセツイタクミ	SIZE ADJUST PLATE ASSY	
44-10	S05712001	1	ボタンヒラキササエ	BUTTON OPENER SUPPORT	
44-11	S03605001	1	シメネジ6.35	SCREW, M6.35	
44-12	150556001	1	ナツト6.35	NUT, M6.35	
44-13	115166001	1	ダンネジ4.37	SHOULDER SCREW, M4.37	
44-14	S03606001	1	ストツハーネジ	STOPPER SCREW	
44-15	S03607001	1	ボタンヒラキツメバネ	SPRING	
44-16	S03608001	1	バネカケ	SPRING HOOK	
44-17	014760622	1	アナトメネジ5.95	SET SCREW, SOCKET M5.95	
44-18	025680232	1	ヒラザガネチユウ4.37	WASHER, PLAIN M 4.37	
65	115146001	1	ボタンツカミホルダカケカネ	BUTTON CLAMP HOLDER HOOK	
66	150556001	1	ナツト6.35	NUT, M6.35	
67	S09043000	2	フェルト(L=5)	FELT (L = 5)	
69	S39092000	2	スナツプリテーナ5	SNAP RETAINER 5	
<6, 12, 24針用 / FOR 6, 12, 24 STITCHES>					
5	S03651001	1	ウオームギヤクミ12	WORM GEAR ASSY (12)	
5-1	014770622	2	アナトメネジ6.35クボミ	SET SCREW, SOCKET (CP) M6.35	
6	S03448001	1	ヨコオクリカムクミ12-コX	TRANSVERSE FEED CAM ASSY (12-コX)	
6-1	014770622	2	アナトメネジ6.35クボミ	SET SCREW, SOCKET (CP) M6.35	
<8, 16, 32針用 / FOR 8, 16, 32 STITCHES>					
5	S03445001	1	ウオームギヤクミ16	WORM GEAR ASSY (16)	
5-1	014770622	2	アナトメネジ6.35クボミ	SET SCREW, SOCKET (CP) M6.35	
6	S03446001	1	ヨコオクリカムクミ16-コX	TRANSVERSE FEED CAM ASSY (16-コX)	
6-1	014770622	2	アナトメネジ6.35クボミ	SET SCREW, SOCKET (CP) M6.35	

F. 押工上げ関係 / Presser foot lifter mechanism / Stoffhalterhebevorrichtung /
 Mécanisme de leveur du pinceur / Mecanismo del levantador de ménsula de trabajo

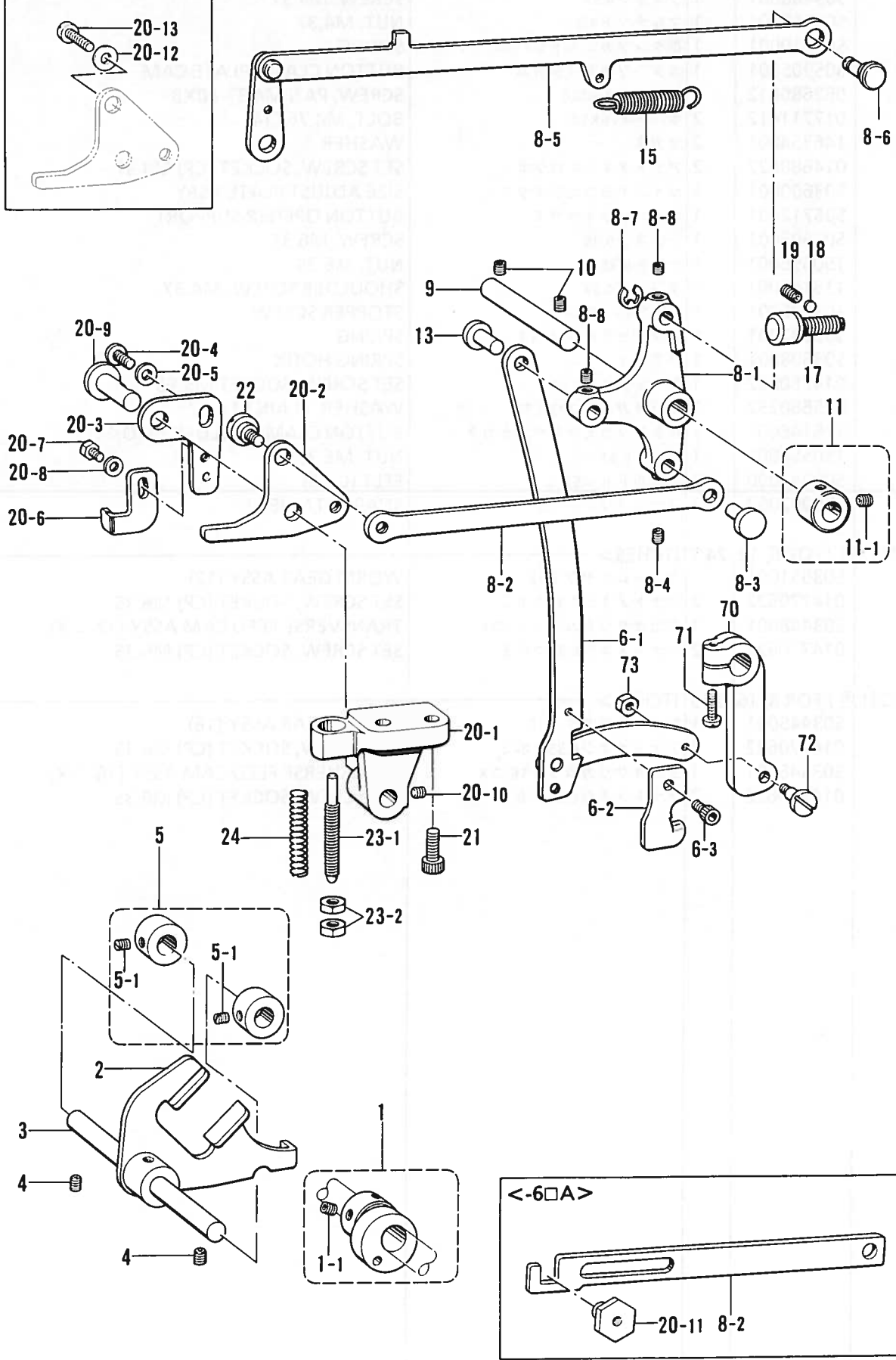
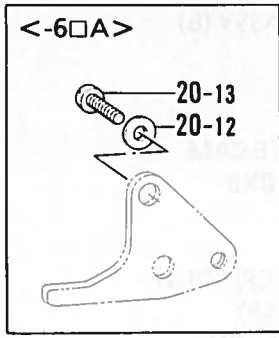

F. 押工上ゲ関係 / Presser foot lifter mechanism / Stoffhalterhebevorrchtung /
 Mécanisme de leveur du pinceur / Mecanismo del levantador de ménsula de trabajo

REF.NO.	CODE	Q'TY	ヒンメイ	NAME OF PARTS	RM
<共通部品/COMMON PARTS>					
1	S03488001	1	サドウカムクミ	DRIVING CAM ASSY	
1-1	014770622	2	アナトメネジ6.35クボミ	SET SCREW, SOCKET (CP) M6.35	
2	S03489101	1	ボタンツカミサドウフタマタ	BUTTON CLAMP DRIVING FORK	
3	115126001	1	サドウフタマタジク	BUTTON CLAMP DRIVING FORK SHAFT	
4	014760622	2	アナトメネジ5.95	SET SCREW, SOCKET (CP) M5.95	
5	S03490001	2	セツトカラークミ	SET SCREW COLLAR ASSY	
5-1	013710512	4	トメネジ4.76クボミ	SET SCREW, (CP) M4.76	
6	S36629001	1	サドウレンカンクミ	DRIVING CONNECTOR ASSY	
6-1	S36630001	1	レンカンクミ	CONNECTOR ASSY	
6-2	S03496101	1	サドウレンカンツメ	DRIVING ROD CLAW	
6-3	018680822	1	アナボルト4.37X8	BOLT, SOCKET M4.37X8	
8-1	S03501000	1	オサエサドウレバー	PRESSER DRIVING LEVER	
8-3	S03503001	1	オサエアゲレンケツジク	PRESSER CONNECT STUD	
8-4	014680622	1	アナトメネジ4.37クボミ	SET SCREW, SOCKET (CP) M4.37	
8-5	S03504001	1	イトユルメカンクミ	TENSION RELEASE CONNECT ROD ASSY	
8-6	S03508001	1	イトユルメカンチヨウセツジク	TENSION RELEASE ADJUST STUD	
8-7	048050342	1	トメワE5	RETAINING RING, E5	
8-8	014680622	2	アナトメネジ4.37クボミ	SET SCREW, SOCKET (CP) M4.37	
9	S03509001	1	オサエサドウレバークミ	PRESSER DRIVING LEVER SHAFT	
10	014760622	2	アナトメネジ5.95	SET SCREW, SOCKET (CP) M5.95	
11	S03704002	1	セツトカラークミ	SET SCREW COLLAR ASSY	
11-1	014770622	2	アナトメネジ6.35クボミ	SET SCREW, SOCKET (CP) M6.35	
13	S03503001	1	オサエアゲレンケツジク	PRESSER CONNECT STUD	
15	S36633001	1	ヒキバネ	SPRING, EXTENSION	
17	S03512001	2	ストツハーネジクミ	STOPPER SCREW ASSY	
18	100507000	2	アテカネ	WASHER	
19	013710712	2	トメネジ4.76クボミ	SET SCREW, (CP) M4.76	
20-1	S05709001	1	オサエアゲブラケット	PRESSER LIFTER BRACKET	
20-2	S03517101	1	オサエアゲウデ	PRESSER LIFTER ARM	
20-3	S03613001	1	ツメチヨウセツイタ	CLAW ADJUSTING PLATE	
20-4	062780812	1	ナベコ635-28X8	SCREW, PAN M6.35-28X8	
20-5	025060232	1	ヒラザガネチュウ6	WASHER, PLAIN M 6	
20-6	S03614001	1	ボタンヒラキツメB	BUTTON OPENER CLAW (B)	
20-7	146360002	1	ボルト476X7	BOLT, M4.76X7	
20-8	146354001	1	ザガネ	WASHER	
20-9	S03518001	1	オサエアゲウデジク	PRESSER LIFTER ARM STUD	
20-10	014760622	1	アナトメネジ5.95	SET SCREW, SOCKET (CP) M5.95	
21	018062022	2	アナボルト6X20	BOLT, SOCKET M6X20	
23	S03519001	1	オサエバネアンナイクミB	SPRING GUIDE ASSY (B)	
23-1	S03520001	1	オサエバネアンナイB	SPRING GUIDE (B)	
23-2	110744002	2	ナツト6.35	NUT, M6.35	
24	S03521001	1	ボタンツカミオサエオシバネ	SPRING	
70	S37439000	1	ボタンツカミサドウレバー	BUTTON CLAMP DRIVING LEVER	
71	062761612	1	ナベコ595-28X16	SCREW, PAN M5.95-28X16	
72	156874001	1	ダンネジ4.76	SHOULDER SCREW, M4.37	
73	110161004	1	ナツト4.76	NUT, M4.76	
<-5□A>					
8	S03500001	1	オサエサドウレバークミ	PRESSER DRIVING LEVER ASSY	
8-2	S03502001	1	オサエアゲレンケツイタ	PRESSER LIFTER CONNECT PLATE	
20	S09362001	1	オサエアゲウデクミ917C	PRESSER LIFTER ARM ASSY 917 (C)	
22	145480101	1	ダンネジ6.35	SHOULDER SCREW, M6.35	
<-6□A>					
8	S05674001	1	オサエサドウレバークミB	PRESSER DRIVING LEVER ASSY (B)	
8-2	S05682001	1	オサエアゲレンケツイタ	PRESSER LIFTER CONNECT PLATE	
20	S05676001	1	オサエアゲウデクミ917B	PRESSER LIFTER ARM ASSY 917 (B)	
20-11	S05683001	1	オサエウデピン	PIN	
20-12	025680232	1	ヒラザガネチュウ4.37	WASHER, PLAIN M 4.37	
20-13	105191001	1	シメネジ4.37	SCREW, M4.37	

G. 下軸関係 / Lower shaft mechanism / Untere Welle / Mécanisme de l'arbre inférieur / Mecanismo del eje inferior

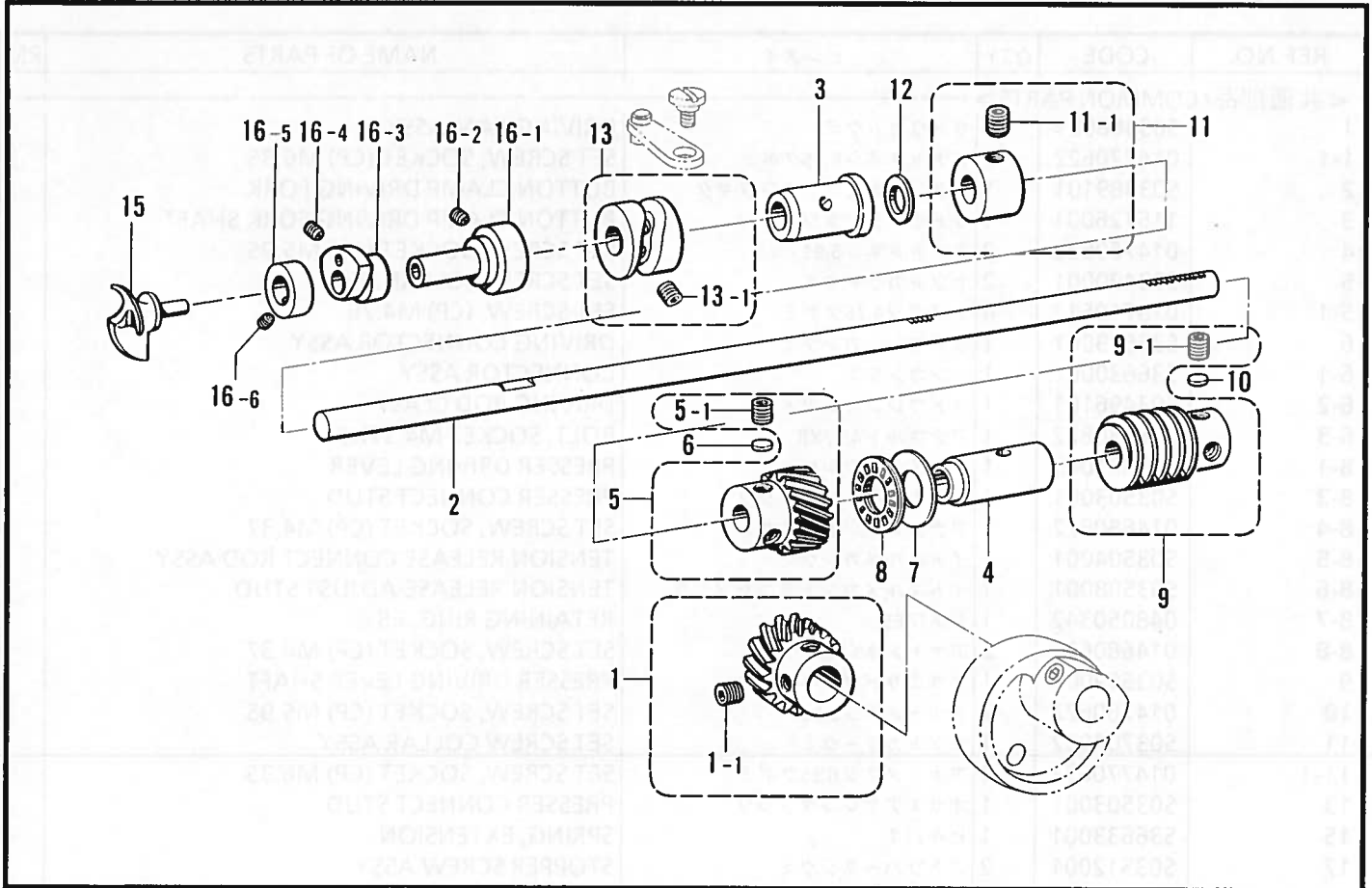

118-917-305

H. 糸切り関係 / Thread trimmer mechanism / Fadenabschneidevorrichtung / Mécanisme de coupe-fil / Mecanismo de la cortadura de hiros

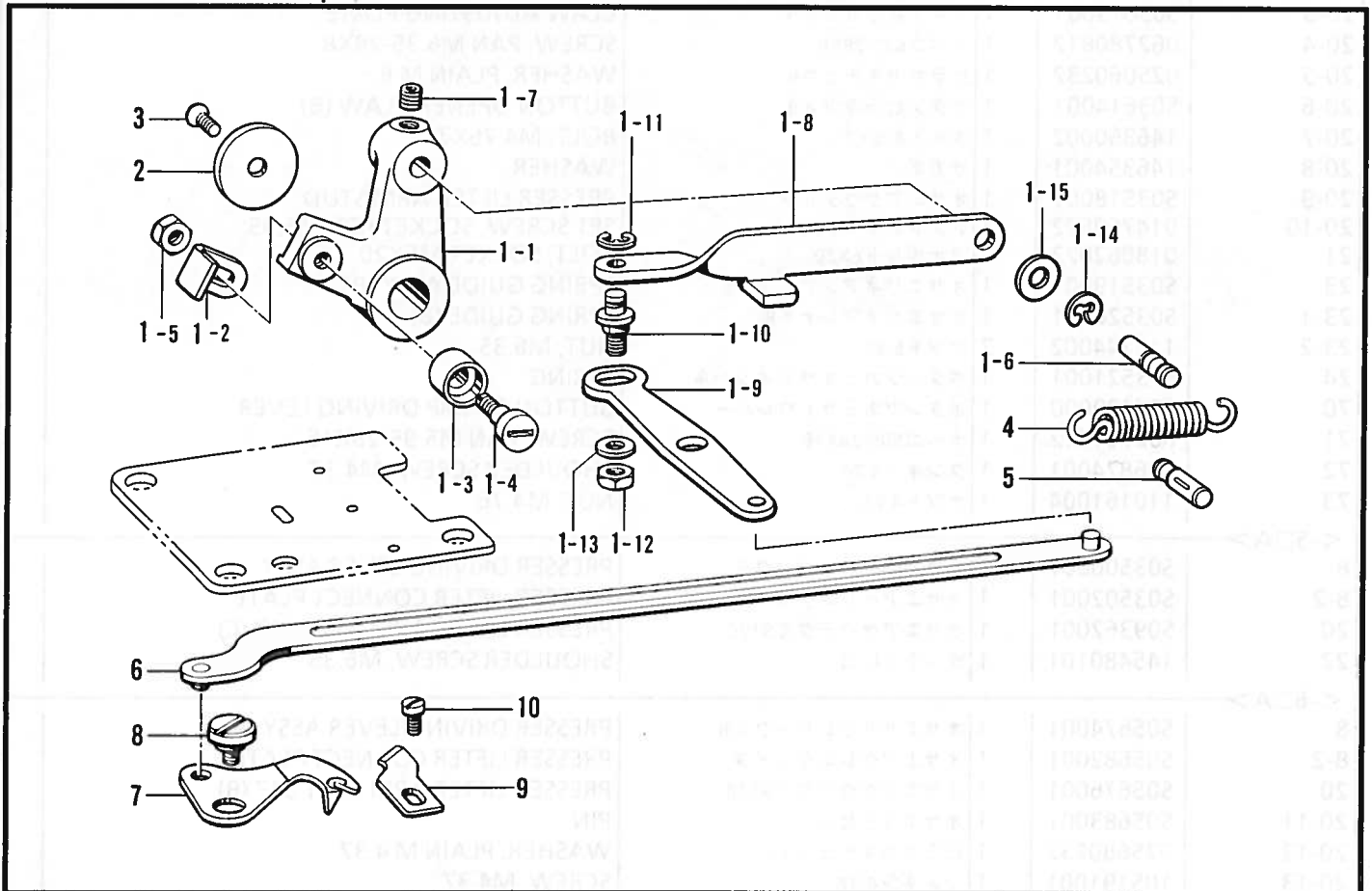

118-917-403

G. 下軸関係 / Lower shaft mechanism / Untere Welle / Mécanisme de l'arbre inférieur /
Mecanismo del eje inferior

REF.NO.	CODE	Q'TY	ヒンメイ	NAME OF PARTS	RM
1	S03522001	1	ヘリカルギヤクミ	HELICAL GEAR ASSY	
1-1	014770622	2	アナトメネジ6.35クボミ	SET SCREW, SOCKET (CP) M6.35	
2	S03523101	1	シタジク	LOWER SHAFT	
3	S03524000	1	シタジクメタルF	LOWER SHAFT BUSH (F)	
4	S03525000	1	シタジクメタルB	LOWER SHAFT BUSH (B)	
5	S03526001	1	シタジクヘリカルギヤクミ	LOWER SHAFT GEAR ASSY	
5-1	014770622	2	アナトメネジ6.35クボミ	SET SCREW, SOCKET (CP) M6.35	
6	147151000	1	トメザガネ	WASHER	
7	S10668001	1	ザガネ	WASHER	
8	115008000	1	タマジクウケ	BALL BEARING	
10	147151000	1	トメザガネ	WASHER	
11	183943001	1	セツトカラークミ	SET SCREW COLLAR ASSY	
11-1	S39974001	2	アナクボミ6.35-40X5	SET SCREW, SOCKET (CP) M6.35-40X5	
12	107153001	1	ザガネ	WASHER	
13	S03533001	1	イトサバキミゾカムクミ	GROOVED CAM ASSY	
13-1	110124001	2	トメネジ5.56	SET SCREW, M5.56	
15	S03536001	1	ルーバー	ROTARY LOOPER	
16	S36699001	1	デルタカムクミ	TRIANGULAR CAM ASSY	
16-1	115066000	1	ルーハトリツケジク	LOOPER SETTING SHAFT	
16-2	013750512	2	トメネジ5.56クボミ	SET SCREW, (CP) M5.56	
16-3	115067001	1	イトサバキデルタカム	THREAD HANDLER TRIANGULAR CAM	
16-4	151601002	2	トメネジ4.37	SET SCREW, M4.37	
16-5	115068101	1	セツトカラー	SET SCREW COLLAR	
16-6	151602001	1	トメネジ4.37	SET SCREW, M4.37	
<6, 12, 24針用 / FOR 6, 12, 24 STITCHES>					
9	S03653001	1	ウオームクミ12	WORM ASSY (12)	
9-1	014770622	3	アナトメネジ6.35クボミ	SET SCREW, SOCKET (CP) M6.35	
<8, 16, 32針用 / FOR 8, 16, 32 STITCHES>					
9	S03528001	1	ウオームクミ16	WORM ASSY (16)	
9-1	014770622	3	アナトメネジ6.35クボミ	SET SCREW, SOCKET (CP) M6.35	

118-917-305

H. 糸切り関係 / Thread trimmer mechanism / Fadenabschneidevorrichtung /
Mécanisme de coupe-fil / Mecanismo de la cortadura de hiros

REF.NO.	CODE	Q'TY	ヒンメイ	NAME OF PARTS	RM
1	S37369001	1	イトキリレバークミ	THREAD TRIMMER LEVER ASSY	
1-1	S36617001	1	イトキリレバー	THREAD TRIMMER LEVER	
1-2	S03406101	1	ツメ	CLAW	
1-3	S03407001	1	コロ	ROLLER	
1-4	S03408001	1	コロダンネジ	SHOULDER SCREW	
1-5	110161004	1	ナット4.76	NUT, M4.76	
1-6	S34278001	1	バネカケジク	SPRING HANGER SHAFT	
1-7	014760622	1	アナトメネジ5.95	SET SCREW, SOCKET (CP) M5.95	
1-8	S03621001	1	イトキリレンケツカン	CONNECTING BAR	
1-9	S03622101	1	イトキリレンケツレバー	CONNECTING LEVER	
1-10	S03623001	1	レンケツカンジク	CONNECTING BAR SHAFT	
1-11	048050342	1	トメワE5	RETAINING RING, E5	
1-12	150553001	1	ナット5.95	NUT, M5.95	
1-13	025060232	1	ヒラザガネチユウ6	WASHER, PLAIN M 6	
1-14	048040342	1	トメワE4	RETAINING RING, E4	
1-15	155559001	1	ヒラザガネ	WASHER, PLAIN	
2	151932001	1	ジクウケフタ	BEARING COVER	
3	107231002	1	サラネジ4.76	SCREW, FLAT M4.76	
4	S03624001	1	イトキリレバーバネ	SPRING	
5	S34298001	1	ミゾツキピン	DOWEL PIN	
6	S03626001	1	イトキリレンカンクミ	THREAD TRIMMER CONNECTING ROD ASSY	
7	S03627001	1	イドウハ	MOVABLE KNIFE	
8	S03628001	1	イドウハダンネジ	MOVABLE KNIFE SHOULDER SCREW	
9	S03629001	1	コテイハ	FIXED KNIFE	
10	106629002	1	シメネジ4.37	SCREW, M4.37	

118-917-403

J. 糸通シ関係 / Threading mechanism / Fadenführungsrichtung / Mécanisme de l'enfilage / Mecanismo del enhebrado

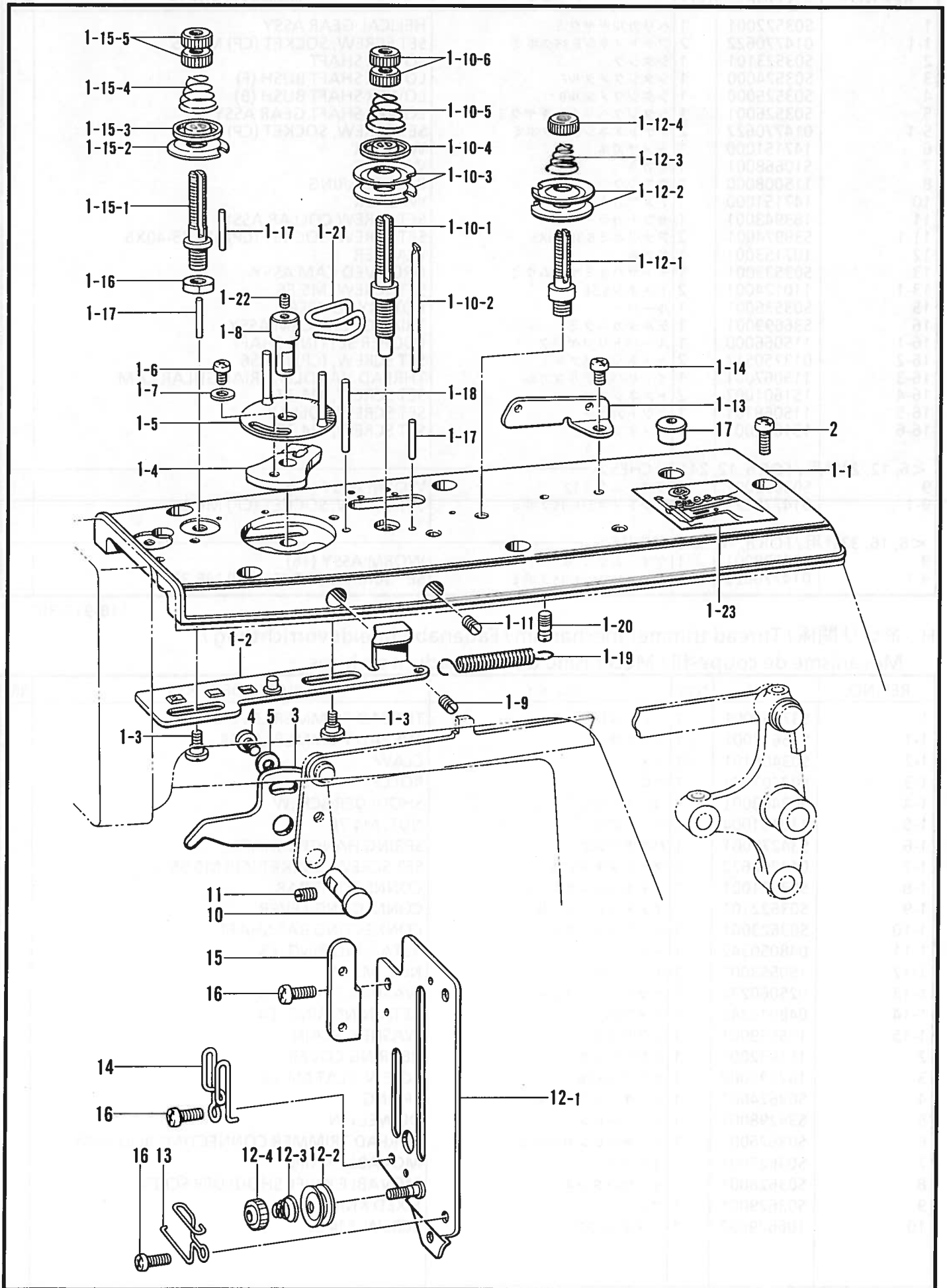

J. 糸通シ関係 / Threading mechanism / Fadenführungsrichtung / Mécanisme de l'enfilage / Mecanismo del enhebrado

REF.NO.	CODE	Q'TY	ヒンメイ	NAME OF PARTS	RM
1	S03615109	1	ウワブタクミ917	TOP COVER ASSY	
1-1	S03538109	1	ウワフタ	TOP COVER	
1-2	S03616101	1	スライダークミB	SLIDER ASSY (B)	
1-3	S03540001	2	ダンネジ4.76	SHOULDER SCREW, M4.76	
1-4	S03541001	1	ローターベース	ROTOR BASE	
1-5	S03542001	1	ロータークミ	ROTOR ASSY	
1-6	062710612	1	ナベコ476-32X6	SCREW, PAN M4.76-32X6	
1-7	146354001	1	ザガネ	WASHER	
1-8	S03543101	1	ロータージク	ROTOR SHAFT	
1-9	013710712	1	トメネジ4.76クボミ	SET SCREW, (CP) M4.76	
1-10	S03544101	1	フクイトチヨウシボウクミ	SUB TENSION STUD ASSY	
1-10-1	S03545001	1	フクイトチヨウシボウ	SUB TENSION STUD	
1-10-2	S03546001	1	ユルメピン	PIN	
1-10-3	115187101	2	イトチヨウシサラ	TENSION DISC	
1-10-4	159805001	1	イトチヨウシサラオサエ	TENSION DISC PRESSER	
1-10-5	148924101	1	イトチヨウシバネ	TENSION SPRING	
1-10-6	100136001	2	イトチヨウシナツト	TENSION NUT	
1-11	013710712	1	トメネジ4.76クボミ	SET SCREW, (CP) M4.76	
1-12	S06057001	1	シュイトチヨウシボウクミ	MAIN TENSION STUD ASSY	
1-12-1	115186001	1	シュイトチヨウシボウ	MAIN THREAD TENSION STUD	
1-12-2	115187101	2	イトチヨウシサラ	TENSION DISC	
1-12-3	115188002	1	シュイトチヨウシバネ	TENSION SPRING	
1-12-4	100136001	1	イトチヨウシナツト	TENSION NUT	
1-13	115183101	1	イトカケ	THREAD GUIDE	
1-14	062710612	1	ナベコ476-32X6	SCREW, PAN M4.76-32X6	
1-15	S03549001	1	イトオサエチヨウシボウクミ	THREAD PRESSER TENSION STUD ASSY	
1-15-1	S03550001	1	イトオサエチヨウシボウ	THREAD PRESSER TENSION STUD	
1-15-2	115187101	1	イトチヨウシサラ	TENSION DISC	
1-15-3	159805001	1	イトチヨウシサラオサエ	TENSION DISC PRESSER	
1-15-4	S06432001	1	イトチヨウシバネ	TENSION SPRING	
1-15-5	100136001	2	イトチヨウシナツト	TENSION NUT	
1-16	150556001	1	ナツト6.35	NUT, M6.35	
1-17	S03551001	4	ユルメピン	PIN	
1-18	S03556001	1	ピン3	PIN 3	
1-19	S03557001	1	スライダークミヒキバネ	SPRING, EXTENSION	
1-20	S03558001	1	バネカケ	SPRING HOOK	
1-21	S06253201	1	ロータージクイトカケ	THREAD GUIDE	
1-22	014680622	1	アナトメネジ4.37クボミ	SET SCREW, SOCKET (CP) M4.37	
1-23	S16253001	1	イトトオシセツメイイタ	THREAD DIAGRAM	
2	062711012	5	ナベコ476-32X10	SCREW, PAN M4.76-32X10	
3	S03617001	1	イトトリレバー	THREAD TAKE-UP LEVER	
4	062711012	1	ナベコ476-32X10	SCREW, PAN M4.76-32X10	
5	146354001	1	ザガネ	WASHER	
10	S03560001	1	イトトリレバージク	THREAD TAKE-UP LEVER SHAFT	
11	013710712	1	トメネジ4.76クボミ	SET SCREW, (CP) M4.76	
12	S03561201	1	メンイタクミ	FACE PLATE ASSY	
12-1	S03377101	1	メンイタクミコ	FACE PLATE SMALL ASSY	
12-2	144504001	2	イトアンナイサラ	THREAD GUIDE DISC	
12-3	144505000	1	イトアンナイバネ	SPRING	
12-4	155510001	1	イトチヨウシナツト	TENSION NUT	
13	S03564001	1	サブテンションイトアンナイ	SUB TENSION THREAD GUIDE	
14	S03565001	1	メンイタイトアンナイ	FACE PLATE THREAD GUIDE	
15	S03566001	1	メンイタイトカケ	FACE PLATE THREAD HOOK	
16	062711012	4	ナベコ476-32X10	SCREW, PAN M4.76-32X10	
17	112758009	1	ベツドオイルフタ	OIL CAP	

K. 糸サバキ関係 / Thread trimmer mechanism / Fadenabschneidevorrichtung /
 Mécanisme de coupe-fil / Mecanismo de la cortadura de hiros

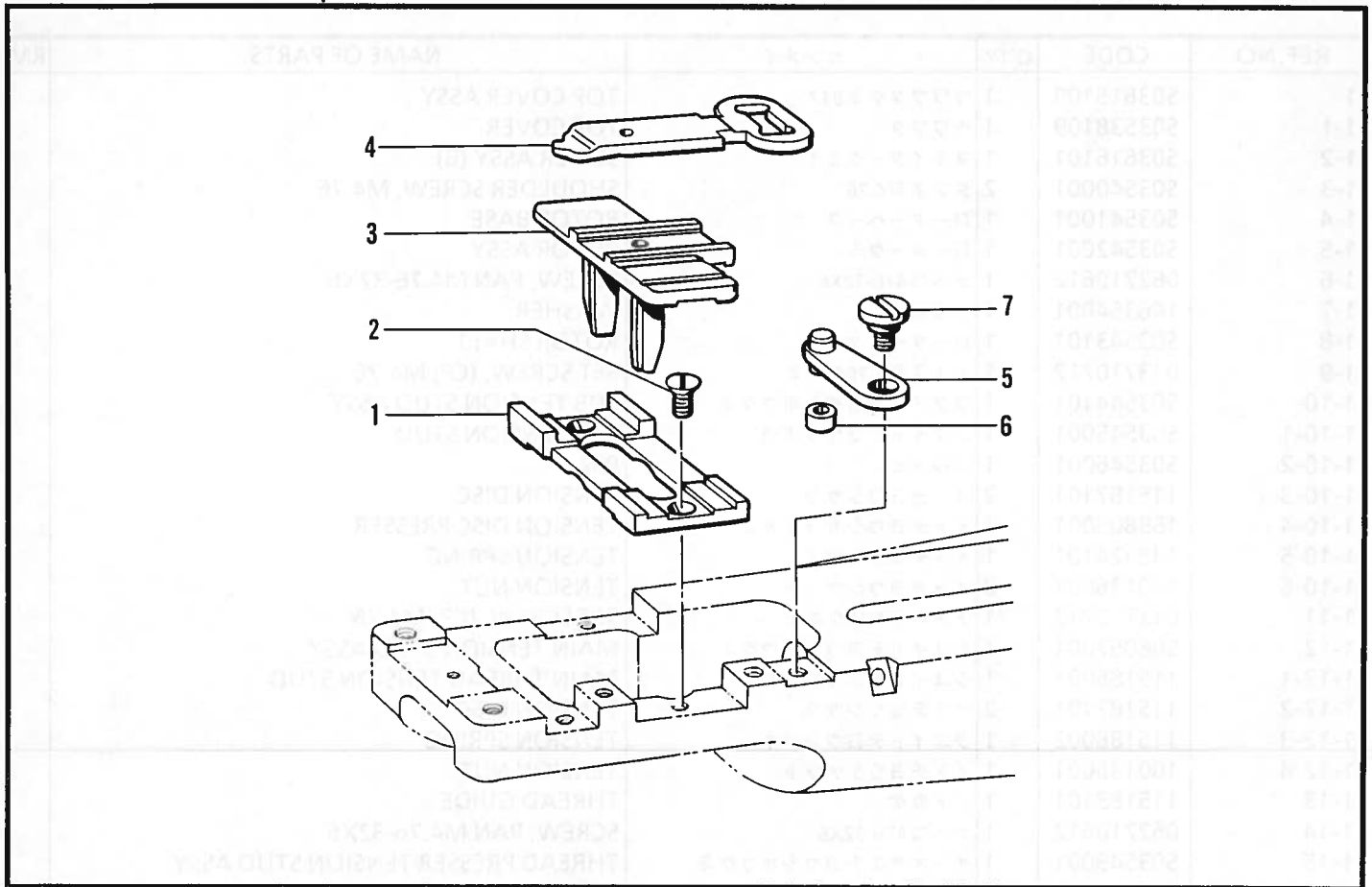

118-917-403

L. 糸払い関係 / Thread wiper mechanism / Fadenwischvorrichtung / Mécanisme de tire-fil /
 Mecanismo del limpiador de hilo

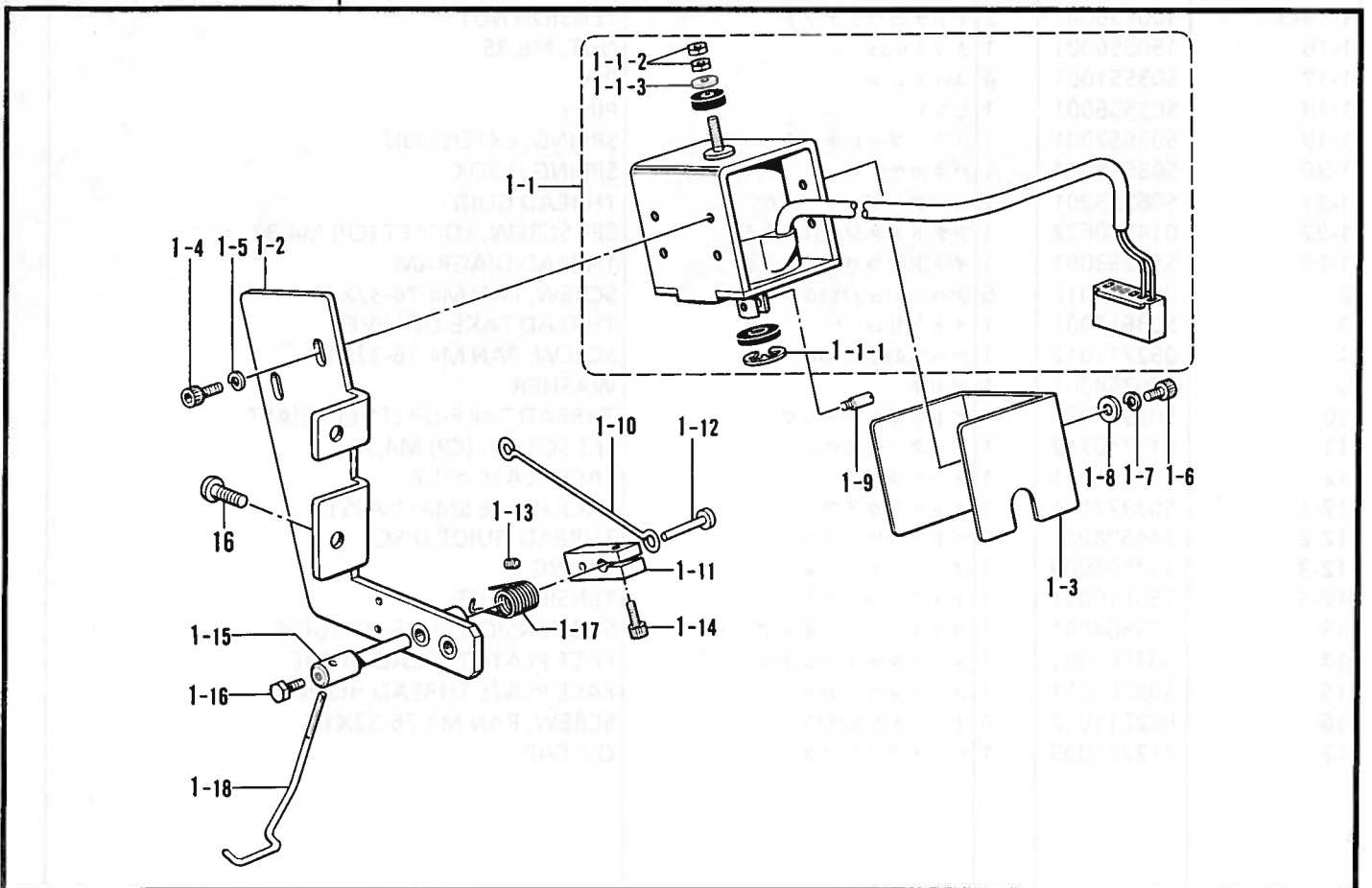

151-910-405

K. 糸サバキ関係 / Loop spreading mechanism / Schleifenzieher /
Etirement de boucle / Ensanche de bucle

REF.NO.	CODE	Q'TY	ヒンメイ	NAME OF PARTS	RM
1	S03567001	1	イトサバキダイ	THREAD HANDLER BRACKET	
2	S01696001	2	サラネジ3.57X6	SCREW, FLAT M3.57X6	
3	S36624001	1	イトサバキアンナイイタ	THREAD HANDLER GUIDE PLATE	
4	S36625001	1	イトサバキ	THREAD HANDLER	
5	115073001	1	イトサバキリンククミ	THREAD HANDLER LINK ASSY	
6	115076001	1	イトサバキリンクコロ	THREAD HANDLER LINK ROLLER	
7	115077001	1	ダンネジ4.76	SHOULDER SCREW, M4.76	

118-917-411

L. 糸払イ関係 / Thread wiper mechanism / Fadenwischvorrichtung / Mécanisme de tire-fil /
Mecanismo del limpiador de hilo

REF.NO.	CODE	Q'TY	ヒンメイ	NAME OF PARTS	RM
1	S11147009	1	ワイパークミB	WIPER ASSY (B)	
1-1	S05444009	1	ワイパーソレノイドクミ	WIPER SOLENOID ASSY	
1-1-1	048090342	1	トメワE9	RETAINING RING, E9	
1-1-2	021300103	2	ナツト1シユ3	NUT, 1 M3	
1-1-3	025030132	1	ヒラザガネシヨウ3	WASHER, PLAIN S 3	
1-2	S05448009	1	ソレノイドベース	SOLENOID BASE	
1-3	S05449009	1	ソレノイドカバー	SOLENOID COVER	
1-4	018400832	2	アナボルト4X8	BOLT, SOCKET M4X8	
1-5	028040242	2	バネザガネ2-4	WASHER, SPRING 2-4	
1-6	018400632	2	アナボルト4X6	BOLT, SOCKET M4X6	
1-7	028040242	2	バネザガネ2-4	WASHER, SPRING 2-4	
1-8	025040232	2	ヒラザガネチユウ4	WASHER, PLAIN M 4	
1-9	148546001	1	プランジャピン	PLUNGER PIN	
1-10	S05450001	1	レンケツリンク	CONNECTION LINK	
1-11	S05451001	1	イトハライリンク	THREAD WIPER LINK	
1-12	S05452001	1	リンクピン	PIN	
1-13	014400522	1	アナクボミ4X5	SET SCREW, SOCKET (CP) M4X5	
1-14	018401022	1	アナボルト4X10	BOLT, SOCKET M4X10	
1-15	S11081001	1	イトハライジクB	WIPER SHAFT (B)	
1-16	017400602	1	ボルト4X6	BOLT, M4X6	
1-17	S05455001	1	イトハライバネ	SPRING	
1-18	S06466001	1	イトハライ	WIPER	
16	062761212	2	ナベコ595-28X12	SCREW, PAN M5.95-28X12	

151-910-405

M. 渡り糸関係 / Crossover stitch mechanism / Verbindungstichvorrichtung /
Mécanisme de point zigzag double / Mechanismo de puntada cruzada

<-6□A>

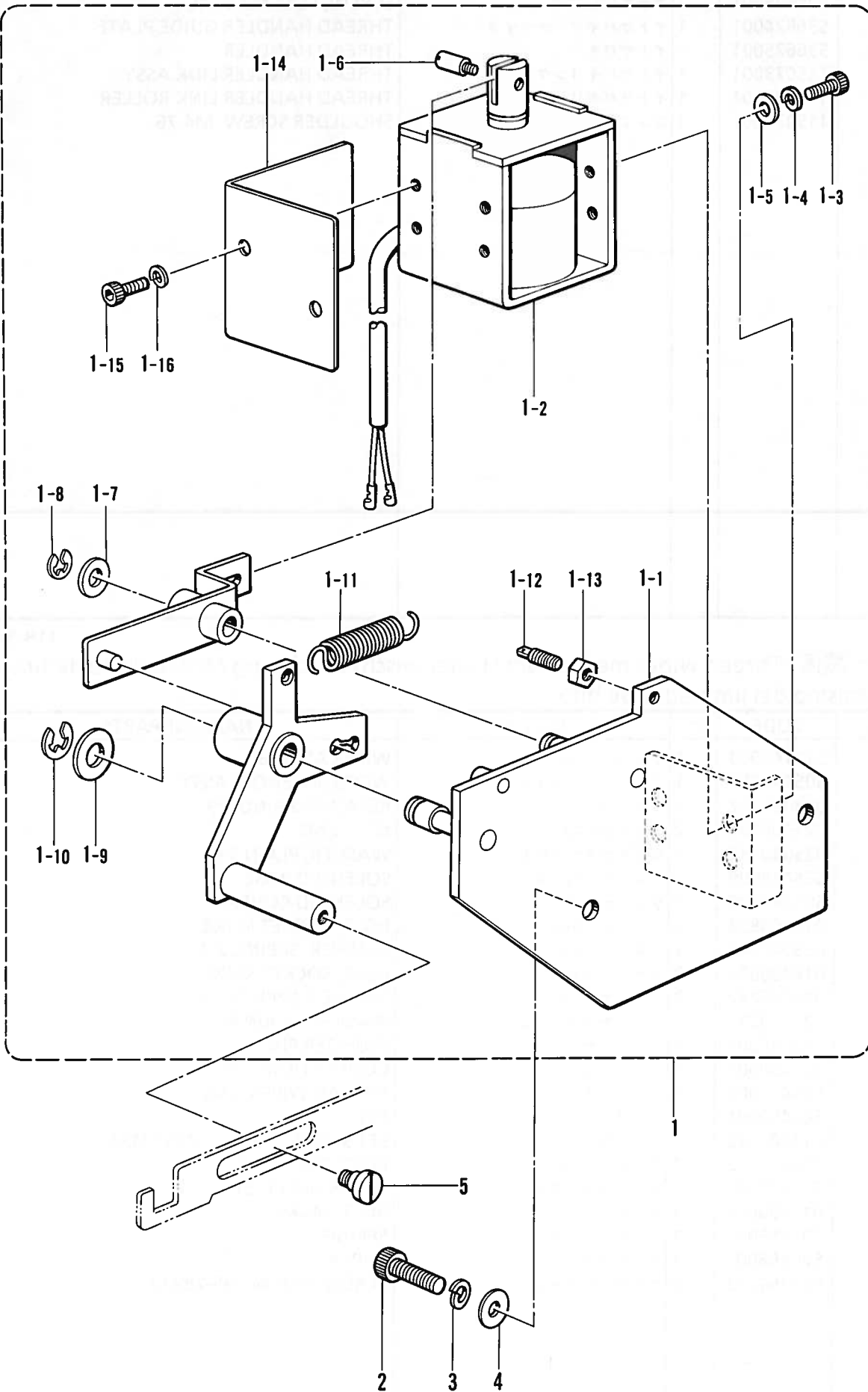

118-917-420

M. 渡り糸関係 / Crossover stitch mechanism / Verbindungstichvorrichtung /
 Mécanisme de point zigzag double / Mechanismo de puntade cruzada

REF.NO.	CODE	Q'TY	ヒンメイ	NAME OF PARTS	RM
<-6□A>					
1	S05690009	1	キリカエソウチクミ	SELECTOR DEVICE ASSY	
1-1	S05691009	1	キリカエベースクミ	SELECTOR BASE ASSY	
1-2	S05695009	1	ワタライトソレノイドクミ	CROSSOVER STITCH SOLENOID ASSY	
1-3	018400832	4	アナボルト4X8	BOLT, SOCKET M4X8	
1-4	028040242	4	バネザガネ2-4	WASHER, SPRING 2-4	
1-5	025040232	4	ヒラザガネチユウ4	WASHER, PLAIN M 4	
1-6	148546001	1	フランジヤピン	PLUNGER PIN	
1-7	025060232	1	ヒラザガネチユウ6	WASHER, PLAIN M 6	
1-8	048040342	1	トメワE4	RETAINING RING, E4	
1-9	025080232	1	ヒラザガネチユウ8	WASHER, PLAIN M 8	
1-10	048060342	1	トメワE6	RETAINING RING, E6	
1-11	S05696001	1	キリカエレンカンバネ	SPRING	
1-12	110251001	1	ヌノオサエウデバネカケ	SPRING HOOK	
1-13	021670202	1	ナツト2シユ3.57	NUT, 2 M3.57	
1-14	S05906009	1	ソレノイドカバー	SOLENOID COVER	
1-15	018400632	2	アナボルト4X6	BOLT, SOCKET M4X6	
1-16	028040242	2	バネザガネ2-4	WASHER, SPRING 2-4	
2	018061622	2	アナボルト6X16	BOLT, SOCKET M6X16	
3	028060242	2	バネザガネ2-6	WASHER, SPRING 2-6	
4	025060232	2	ヒラザガネチユウ6	WASHER, PLAIN M 6	
5	159272001	1	メスサドウレバダンネジ	SHOULDER SCREW	

N. 起動裝置關係 / Starting device mechanism / Startvorrichtung / Mécanisme de dispositif de démarrage / Mecanismo del dispositivo de arranque

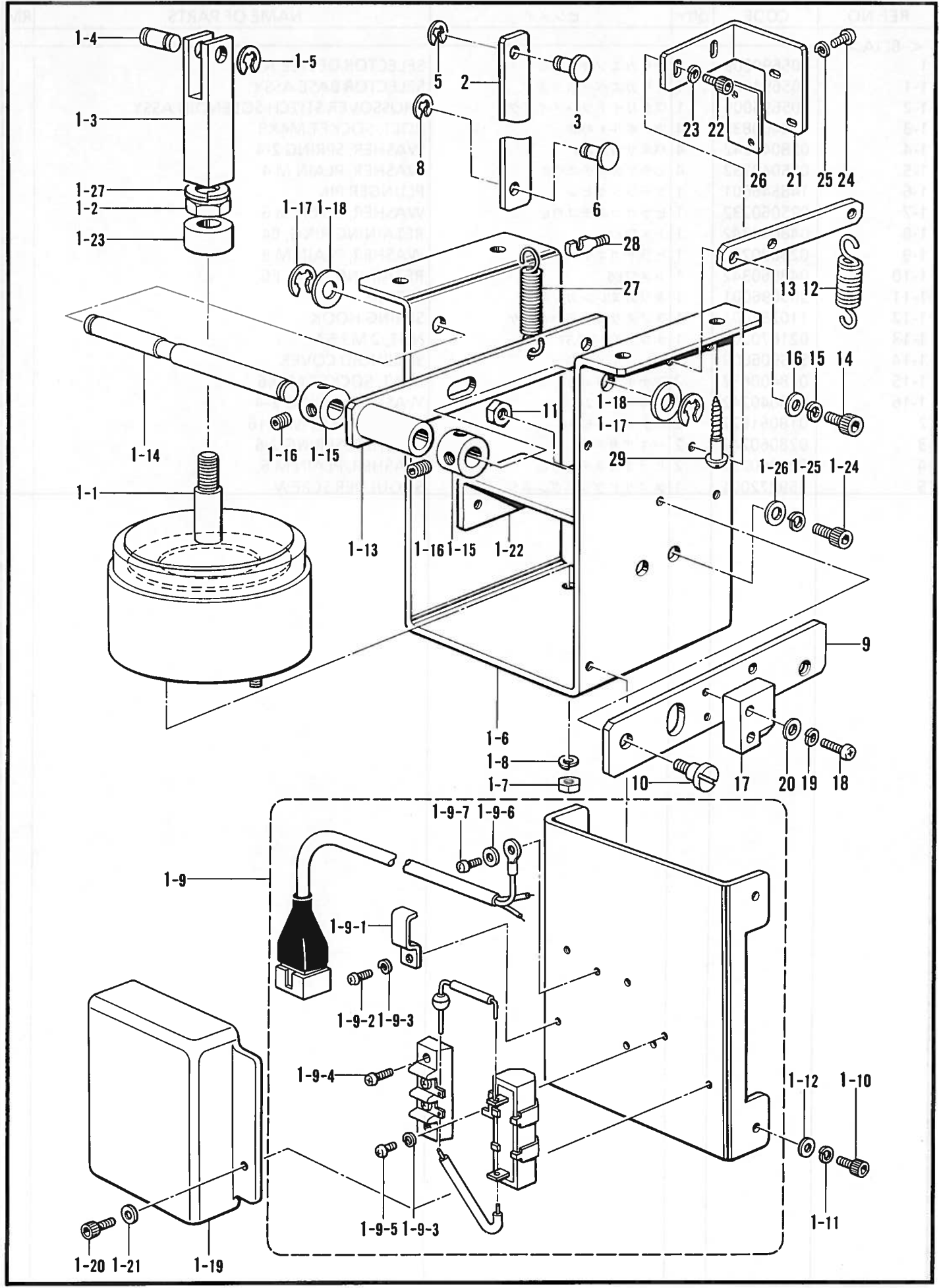

N. 起動装置関係 / Starting device mechanism / Startvorrichtung /
 Mécanisme de dispositif de démarrage / Mecanismo del dispositivo de arranque

REF.NO.	CODE	Q'TY	ヒンメイ	NAME OF PARTS	RM
1	S05462009	1	キドウソウチクミ	STARTING DEVICE ASSY	
1-1	S02582001	1	オサエアゲソレノイドクミ	PRESSER BAR LIFTER SOLENOID ASSY	
1-2	021080302	1	ナツト3シユ8	NUT, 3 M8	
1-3	S05974001	1	プランジャツギテ	PLANGER CONNECTOR	
1-4	S31024001	1	ピン	PIN	
1-5	048060342	2	トメワE6	RETAINING RING, E6	
1-6	S05464009	1	ソレノイドダイ	SOLENOID BASE	
1-7	021060102	2	ナツト1シユ6	NUT, 1 M6	
1-8	028060242	2	バネザガネ2-6	WASHER, SPRING 2-6	
1-9	S05463009	1	ソレノイドカバークミ	SOLENOID COVER ASSY	
1-9-1	142268001	1	コードオサエL	CORD HOLDER (L)	
1-9-2	062300605	1	ナベコ3X6	SCREW, PAN M3X6	
1-9-3	028030242	2	バネザガネ2-3	WASHER, SPRING 2-3	
1-9-4	002301003	2	+ナベコネジ3X10	SCREW, PAN M3X10	
1-9-5	062300605	1	ナベコ3X6	SCREW, PAN M3X6	
1-9-6	S02745001	1	ザガネ	WASHER	
1-9-7	002400663	1	+ナベコ4X6	SCREW, PAN M4X6	
1-10	018400832	4	アナボルト4X8	BOLT, SOCKET M4X8	
1-11	028040242	4	バネザガネ2-4	WASHER, SPRING 2-4	
1-12	025040232	4	ヒラザガネチユウ4	WASHER, PLAIN M 4	
1-13	S05466001	1	キドウレバー	STARTING LEVER	
1-14	S05467001	1	キドウレバージク	STARTING LEVER SHAFT	
1-15	S05392001	2	セットカラー	SET SCREW COLLAR	
1-16	014060632	4	アナトメ6X6クホミ	SET SCREW, SOCKET (CP) M6X6	
1-17	048080342	2	トメワE8	RETAINING RING, E8	
1-18	025100132	2	ヒラザガネシヨウ10	WASHER, PLAIN S 10	
1-19	S02592009	1	タンシダイカバー	TERMINAL BLOCK COVER	
1-20	018400832	2	アナボルト4X8	BOLT, SOCKET M4X8	
1-21	025040232	2	ヒラザガネチユウ4	WASHER, PLAIN M 4	
1-22	S06152001	1	クツシヨンウケイタ	PLATE	
1-23	153122000	1	ゴムクツシヨン	RUBBER CUSHION	
1-24	018501022	4	アナボルト5X10	BOLT, SOCKET M5X10	
1-25	028050242	4	バネザガネ2-5	WASHER, SPRING 2-5	
1-26	025050232	4	ヒラザガネチユウ5	WASHER, PLAIN M 5	
1-27	028080242	1	バネザガネ2-8	WASHER, SPRING 2-8	
2	S05468001	1	キドウレンカン	STARTING CONNECTING ROD	
3	S05469001	1	キドウレンカンピンB	PIN (B)	
5	048060342	1	トメワE6	RETAINING RING, E6	
6	S05470001	1	キドウレンカンピンA	PIN (A)	
8	048060342	1	トメワE6	RETAINING RING, E6	
9	S05881001	1	フミコミレバー	FOOT SWITCH LEVER	
10	158998001	2	ダンネジ6.35	SHOULDER SCREW, M6.35	
11	150554002	2	ナツト6.35	NUT, M6.35	
12	S05882001	1	フミコミレバーバネ	SPRING	
13	S05883001	1	バネカケ	SPRING HOOK	
14	018501022	2	アナボルト5X10	BOLT, SOCKET M5X10	
15	028050242	2	バネザガネ2-5	WASHER, SPRING 2-5	
16	025050232	2	ヒラザガネチユウ5	WASHER, PLAIN M 5	
17	S05884000	1	スイッチドック	SWITCH DOCK	
18	002401402	2	プラスナベネジ4X14	SCREW, M4X14	
19	028040242	2	バネザガネ2-4	WASHER, SPRING 2-4	
20	025040232	2	ヒラザガネチユウ4	WASHER, PLAIN M 4	
21	S05885001	1	スイッチトリツケイタ	SWITCH SET PLATE	
22	018401022	2	アナボルト4X10	BOLT, SOCKET M4X10	
23	028040242	2	バネザガネ2-4	WASHER, SPRING 2-4	
24	062301606	2	ナベコ3X16	SCREW, PAN M3X16	
25	028030243	2	バネザガネ2-3	WASHER, SPRING 2-3	
26	S05973001	1	トリツケウライタ	SET PLATE	
27	S05989001	1	サドーレバーバネ	SPRING	
28	141334001	1	バネカケ	SPRING HOOK	
29	101125000	3	マルモクネジ6.2X32	WOOD SCREW, ROUND M6.2X32	

P1. ボタンフィーダー関係 / Button feeder mechanism / Knopfzuführungvorrichtung / Alimentation pour boutons / Botón de alimentación

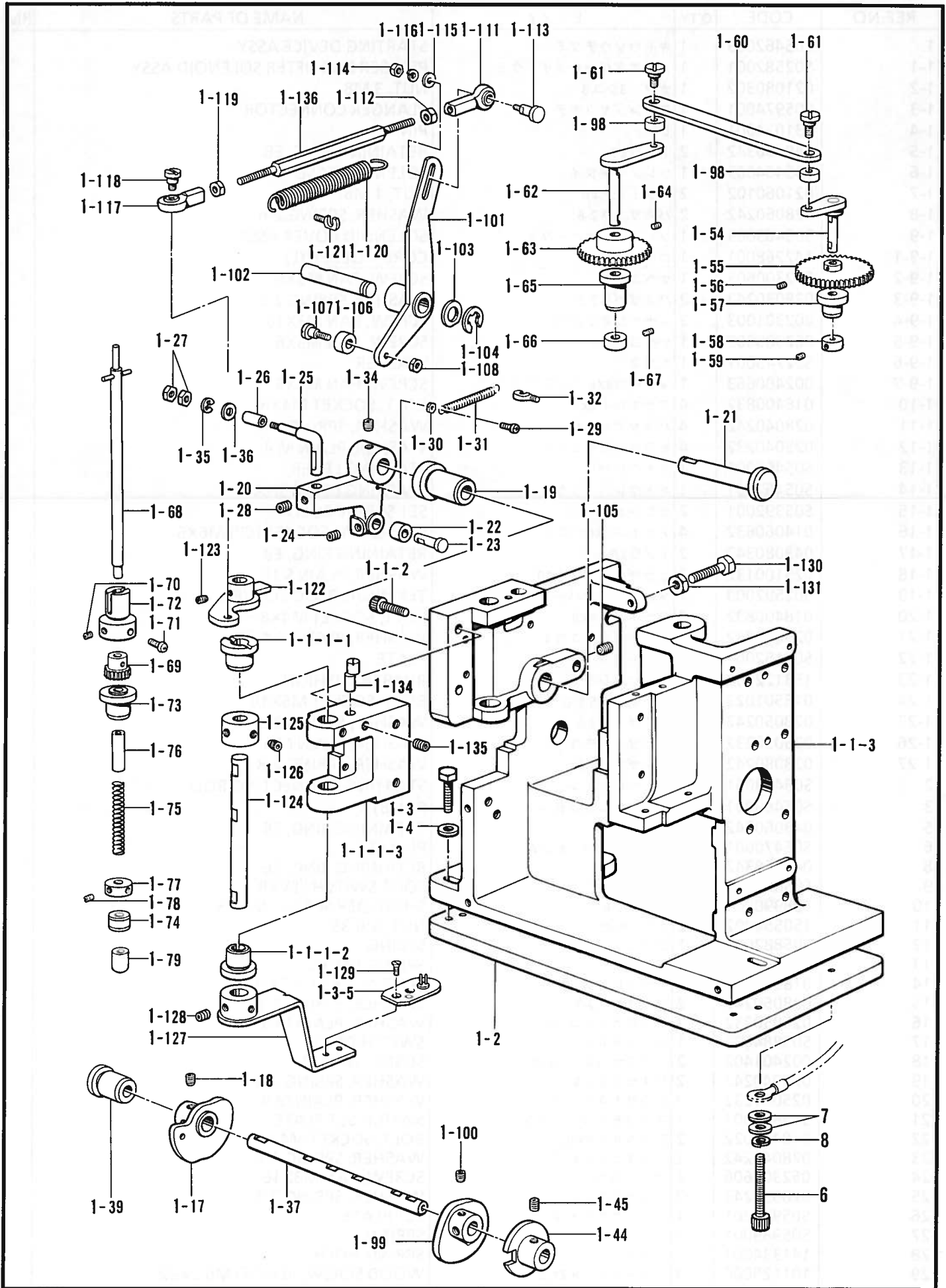

P1. ボタンフィーダー関係 / Button feeder mechanism / Knopfzuführungvorrichtung / Alimentation pour boutons / Botón de alimentación

REF.NO.	CODE	Q'TY	ヒンメイ	NAME OF PARTS	RM
1	S25116009	1	ボタンフィーダーホンタイクミ	BUTTON FEEDER BODY ASSY	
1-1	S07068001	1	フィーダーホンタイクミ	FEEDER MACHINE ASSY	
1-1-1	S07066001	1	BキヤリーササエダイSクミ	BUTTON CARRY SUPPORT BRACKET (S) ASSY	
1-1-1-1	S05378000	1	BウンハンジクメタルU	BUSH (U)	
1-1-1-2	S05379000	1	BウンハンジクメタルD	BUSH (D)	
1-1-1-3	S07063001	1	BキヤリーササエダイS	BUTTON CARRY SUPPORT BRACKET (S)	
1-1-2	018062022	3	アナボルト6X20	BOLT, SOCKET M6X20	
1-1-3	S07064001	1	ボタンフィーダーホンタイ	BUTTON FEEDER MACHINE BODY	
1-2	S05312001	1	ボタンフィーダーベース	BUTTON FEEDER BASE	
1-3	017062003	3	ボルト6X20	BOLT, M6X20	
1-4	025060232	3	ヒラザガネチユウ6	WASHER, PLAIN M 6	
1-17	S05384001	1	オサエアゲカム	PRESSER BAR LIFTER CAM	
1-18	014060632	2	アナトメ6X6クボミ	SET SCREW, SOCKET (CP) M6X6	
1-19	S05385000	1	クランクジクメタル	CRANK SHAFT BUSH	
1-20	S05386001	1	オサエアゲクランク	PRESSER BAR LIFTER CRANK	
1-21	S05387001	1	オサエアゲクランクジク	PRESSER BAR LIFTER CRANK SHAFT	
1-22	S05371001	1	カムフオロアー	CAM SUPPORT	
1-23	S05388001	1	カムフオロワージク	CAM SUPPORT SHAFT	
1-24	014500522	1	アナトメネジ5クボミ	SET SCREW, SOCKET (CP) M5	
1-25	S05389001	1	オサエアゲコロウデジク	PRESSER BAR LIFTER ROLLER ARM SHAFT	
1-26	S05390001	1	オサエアゲコロ	PRESSER BAR LIFTER ROLLER	
1-27	021300103	2	ナツト1シユ3	NUT, 1 M3	
1-28	014500522	1	アナトメネジ5クボミ	SET SCREW, SOCKET (CP) M5	
1-29	062301212	1	ナベコ3X12	SCREW, PAN M3X12	
1-30	021300103	1	ナツト1シユ3	NUT, 1 M3	
1-31	S05391001	1	オサエアゲクランクバネ	SPRING	
1-32	141334001	1	バネカケ	SPRING HOOK	
1-34	014060632	2	アナトメ6X6クボミ	SET SCREW, SOCKET (CP) M6X6	
1-35	028030242	1	バネザガネ2-3	WASHER, SPRING 2-3	
1-36	025030232	1	ヒラザガネチユウ3	WASHER, PLAIN M 3	
1-37	S07070001	1	カムジク	CAM SHAFT	
1-39	S05330000	1	カムジクメタルR	CAM SHAFT BUSH (R)	
1-44	S05333001	1	カムジクスイッチドック	CAM SHAFT SWITCH DOCK	
1-45	014060632	2	アナトメ6X6クボミ	SET SCREW, SOCKET (CP) M6X6	
1-54	S05335001	1	ギヤジクA	GEAR SHAFT (A)	
1-55	S05337000	1	スリモミヨウギヤ	BUTTON ALIGNMENT GEAR	
1-56	014300432	2	アナクボミ3X4	SET SCREW, SOCKET (CP) M3X4	
1-57	S05338000	1	ギヤジクAヨウメタル	GEAR SHAFT (A) BUSH	
1-58	S05339001	1	セツトカラーA	SET SCREW COLLAR (A)	
1-59	014300432	2	アナクボミ3X4	SET SCREW, SOCKET (CP) M3X4	
1-60	S05340001	1	スリモミレンケツレバー	BUTTON ALIGNMENT CONNECTION LEVER	
1-61	S05341001	2	ダンネジM4	SHOULDER SCREW, M4	
1-62	S05342001	1	ギヤジクB	GEAR SHAFT (B)	
1-63	S05343000	1	シャフトギヤA	SHAFT GEAR (A)	
1-64	014500522	2	アナトメネジ5クボミ	SET SCREW, SOCKET (CP) M5	
1-65	S05344000	1	ギヤジクBヨウメタル	GEAR SHAFT (B) BUSH	
1-66	S05345001	1	セツトカラーB	SET SCREW COLLAR (B)	
1-67	014500522	2	アナトメネジ5クボミ	SET SCREW, SOCKET (CP) M5	
1-68	S10701001	1	シャフトクミ	SHAFT ASSY	
1-69	S10703000	1	シャフトギヤB	SHAFT GEAR (B)	
1-70	014300432	1	アナクボミ3X4	SET SCREW, SOCKET (CP) M3X4	
1-71	002300502	1	+ナベ3X5クロ	SCREW, PAN M3X5	
1-72	S10709001	1	スリモミジクアンナイ	BUTTON ALIGNMENT SHAFT GUIDE	
1-73	S10705000	1	スリモミジクメタルA	BUTTON ALIGNMENT SHAFT BUSH (A)	
1-74	S10706000	1	スリモミジクメタルB	BUTTON ALIGNMENT SHAFT BUSH (B)	
1-75	S10704001	1	スリモミオシツケバネ	SPRING	
1-76	S10708001	1	バネアンナイカラー	SPRING GUIDE COLLAR	
1-77	S10707001	1	スリモミジクドック	BUTTON ALIGNMENT SHAFT DOCK	
1-78	014400522	2	アナクボミ4X5	SET SCREW, SOCKET (CP) M4X5	

P1. ボタンフィーダー関係 / Button feeder mechanism / Knopfzuführungvorrichtung / Alimentation pour boutons / Botón de alimentación

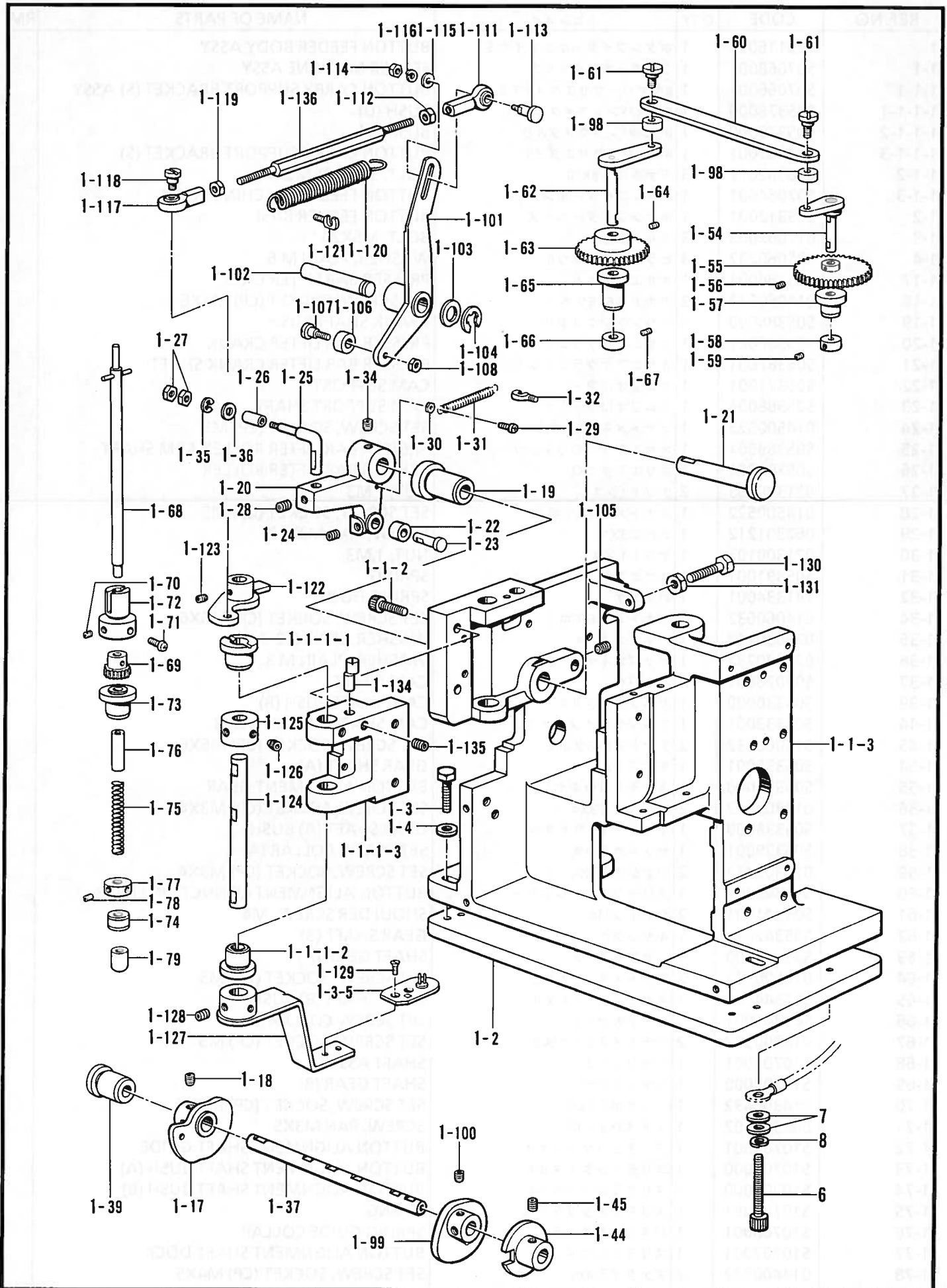

P1. ボタンフィーダー関係 / Button feeder mechanism / Knopfzuführungsvorrichtung /
Alimentation pour boutons / Botón de alimentación

REF.NO.	CODE	Q'TY	ヒンメイ	NAME OF PARTS	RM
1-79	S06570000	1	ボタンオサエC	BUTTON PRESSER (C)	
1-98	S05972000	2	コロ	ROLLER	
1-99	S05368101	1	ボタンキャリーカム	BUTTON CARRY CAM	
1-100	014060632	2	アナトメ6X6クボミ	SET SCREW, SOCKET (CP) M6X6	
1-101	S05369001	1	カムフオロアBヨウアーム	CAM SUPPORT (B) ARM	
1-102	S05370001	1	アームBヨウシテンピン	PIN	
1-103	110367001	1	ザガネ	WASHER	
1-104	048060342	1	トメワE6	RETAINING RING, E6	
1-105	014060632	1	アナトメ6X6クボミ	SET SCREW, SOCKET (CP) M6X6	
1-106	S05371001	1	カムフオロアー	CAM SUPPORT	
1-107	S05341001	1	ダンネジM4	SHOULDER SCREW, M4	
1-108	021400202	1	2シユナツト4	NUT, 2 M4	
1-111	148587001	1	タマツギテクミR	JOINT ASSY (R)	
1-112	100022005	1	ナツト5.95	NUT, M5.95	
1-113	S05373001	1	ダンネジ	SHOULDER SCREW	
1-114	021400202	1	2シユナツト4	NUT, 2 M4	
1-115	025040232	1	ヒラザガネチユウ4	WASHER, PLAIN M 4	
1-116	028040242	1	バネザガネ2-4	WASHER, SPRING 2-4	
1-117	148589001	1	タマツギテクミL	JOINT ASSY (L)	
1-118	S05336001	1	タマツギテダンネジ	SHOULDER SCREW	
1-119	148592001	1	ナツト5.95	NUT, M5.95	
1-120	S05375001	1	カムフオロアBヨウバネA	SPRING (A)	
1-121	141334001	1	バネカケ	SPRING HOOK	
1-122	S05376001	1	ボタンイドウヨウアームB	BUTTON MOVEMENT ARM (B)	
1-123	014060632	2	アナトメ6X6クボミ	SET SCREW, SOCKET (CP) M6X6	
1-124	S07128001	1	ボタンウンパンジク	BUTTON TRANSPORT SHAFT	
1-125	S07129001	1	セツトカラー	SET SCREW COLLAR	
1-126	014060622	2	アナトメネジ6X6クボミ	SET SCREW, SOCKET (CP) M6X6	
1-127	S05380101	1	ボタンイドウヨウアームA	BUTTON MOVEMENT ARM (A)	
1-128	014060632	2	アナトメ6X6クボミ	SET SCREW, SOCKET (CP) M6X6	
1-129	S06044001	2	サラネジ3.57X4	SCREW, FLAT M3.57X4	
1-130	S12415001	1	ボルト6X25	BOLT, M6X25	
1-131	021060106	1	1シユナツト6	NUT, 1 M6	
1-134	S06119001	1	ヘンシンピン	PIN	
1-135	014760622	1	アナトメネジ5.95	SET SCREW, SOCKET (CP) M5.95	
1-136	S05374001	1	レンケツジク	CONNECTION SHAFT	
1-3-5	S06686004	1	ボタンウケダイクミ	BUTTON CATCH PLATE ASSY	
6	018065022	3	アナボルト6X50	BOLT, SOCKET M6X50	
7	115947001	6	ザガネ	WASHER	
8	028060242	3	バネザガネ2-6	WASHER, SPRING 2-6	

P2. ボタンフィーダー関係 / Button feeder mechanism / Knopfzuführungvorrichtung /
Alimentation pour boutons / Botón de alimentación

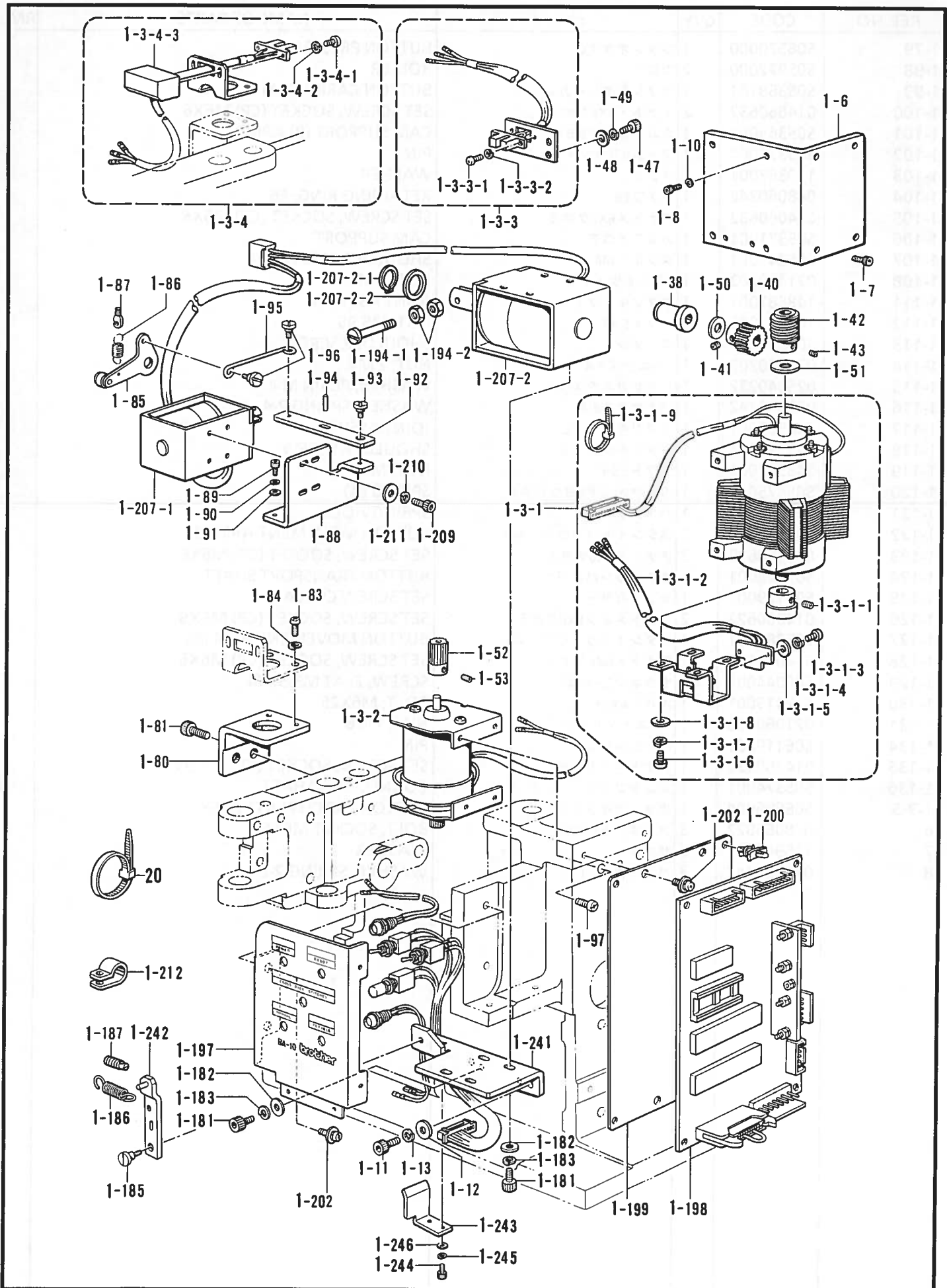

P2. ボタンフィーダー関係 / Button feeder mechanism / Knopfzuführungvorrichtung /
Alimentation pour boutons / Botón de alimentación

REF.NO.	CODE	Q'TY	ヒンメイ	NAME OF PARTS	RM
1-6	S07110001	1	モータートリツケイタ	MOTOR SET PLATE	
1-7	018401022	4	アナボルト4X10	BOLT, SOCKET M4X10	
1-8	018401022	4	アナボルト4X10	BOLT, SOCKET M4X10	
1-10	028040242	4	バネザガネ2-4	WASHER, SPRING 2-4	
1-11	018501222	2	アナボルト5X12	BOLT, SOCKET M5X12	
1-12	025050232	2	ヒラザガネチユウ5	WASHER, PLAIN M 5	
1-13	028050242	2	バネザガネ2-5	WASHER, SPRING 2-5	
1-38	S05329000	1	カムジクメタルF	CAM SHAFT BUSH (F)	
1-40	S05331000	1	ウオームホイール	WORM WHEEL	
1-41	014060632	2	アナトメ6X6クボミ	SET SCREW, SOCKET (CP) M6X6	
1-42	S15497000	1	ウオーム	WORM	
1-43	014500522	2	アナトメネジ5クボミ	SET SCREW, SOCKET (CP) M5	
1-47	018401022	2	アナボルト4X10	BOLT, SOCKET M4X10	
1-48	025040232	2	ヒラザガネチユウ4	WASHER, PLAIN M 4	
1-49	028040242	2	バネザガネ2-4	WASHER, SPRING 2-4	
1-50	S06024001	1	スラストザガネ	THRUST WASHER	
1-51	S06029001	1	ザガネ	WASHER	
1-52	S05334000	1	スリモミモーターギヤ	BUTTON ALIGNMENT MOTOR GEAR	
1-53	014300432	2	アナクボミ3X4	SET SCREW, SOCKET (CP) M3X4	
1-80	S07074001	1	ガイド	GUIDE	
1-81	018401022	2	アナボルト4X10	BOLT, SOCKET M4X10	
1-83	002300803	2	+ナベコ3X8	SCREW, PAN M3X8	
1-84	028030242	2	バネザガネ2-3	WASHER, SPRING 2-3	
1-85	S05359001	1	オシアゲクランククミ	PRESSER BAR CLANK ASSY	
1-86	S05363001	1	スリモミジクヒツハリバネ	SPRING	
1-87	141334001	1	バネカケ	SPRING HOOK	
1-88	S05364001	1	ソレノイドトリツケイタ	SOLENOID SETTING PLATE	
1-89	018401022	3	アナボルト4X10	BOLT, SOCKET M4X10	
1-90	028040242	3	バネザガネ2-4	WASHER, SPRING 2-4	
1-91	025040232	3	ヒラザガネチユウ4	WASHER, PLAIN M 4	
1-92	S05365001	1	ソレノイドレンケツアーム	SOLENOID ARM	
1-93	S05341001	1	ダンネジM4	SHOULDER SCREW, M4	
1-94	148546001	1	プランジャピン	PLUNGER PIN	
1-95	S05767001	1	ワイヤー	WIRE	
1-96	S05341001	2	ダンネジM4	SHOULDER SCREW, M4	
1-97	002350806	4	+ナベコ3.5X8	SCREW, PAN M3.5X8	
1-181	018401022	6	アナボルト4X10	BOLT, SOCKET M4X10	
1-182	025040232	6	ヒラザガネチユウ4	WASHER, PLAIN M 4	
1-183	028040242	6	バネザガネ2-4	WASHER, SPRING 2-4	
1-185	S05424001	1	ダンネジM4	SHOULDER SCREW, M4	
1-186	S09609001	1	シャッターバネ	SPRING	
1-187	S03401001	1	バネカケ	SPRING HOOK	
1-194	S25569001	1	ダンネジ3.18クミ	SHOULDER SCREW, M3.18 ASSY	
1-194-1	S25570001	1	ダンネジ3.18	SHOULDER SCREW, M3.18	
1-194-2	021660306	2	3シユナツト318-40	NUT, 3 M3.18-40	
1-197	S05318009	1	Bパネルクミ	B PANEL ASSY	
1-198	S05323200	1	キバンB438013クミ	CIRCUIT BOARD (B438013) ASSY	
1-199	S05324001	1	キバントリツケイタ	BOARD SET PLATE	
1-200	S00554000	4	サポート6NS	SUPPORT 6NS	
1-202	052400806	6	ナベコバネヒラ4X8	SCREW, PAN (S/P WASHER) M4X8	
1-207	S05738101	1	Bソレノイドクミ	BUTTON SOLENOID ASSY	
1-207-1	S05739000	1	キリモミソレノイド	BUTTON SET SOLENOID	
1-207-2	S05740101	1	シャッターソレノイドクミ	SHUTTER SOLENOID ASSY	
1-207-2-1	048150142	1	トメワジクヨウC15	RETAINING RING, C15	
1-207-2-2	S05743000	1	スパーサー	SPACER	
1-209	018400832	4	アナボルト4X8	BOLT, SOCKET M4X8	
1-210	028040242	4	バネザガネ2-4	WASHER, SPRING 2-4	
1-211	025040232	4	ヒラザガネチユウ4	WASHER, PLAIN M 4	
1-212	149073001	2	コードホルダ	CORD HOLDER	

P2. ボタンフィーダー関係 / Button feeder mechanism / Knopfführungvorrichtung /
 Alimentation pour boutons / Botón de alimentación

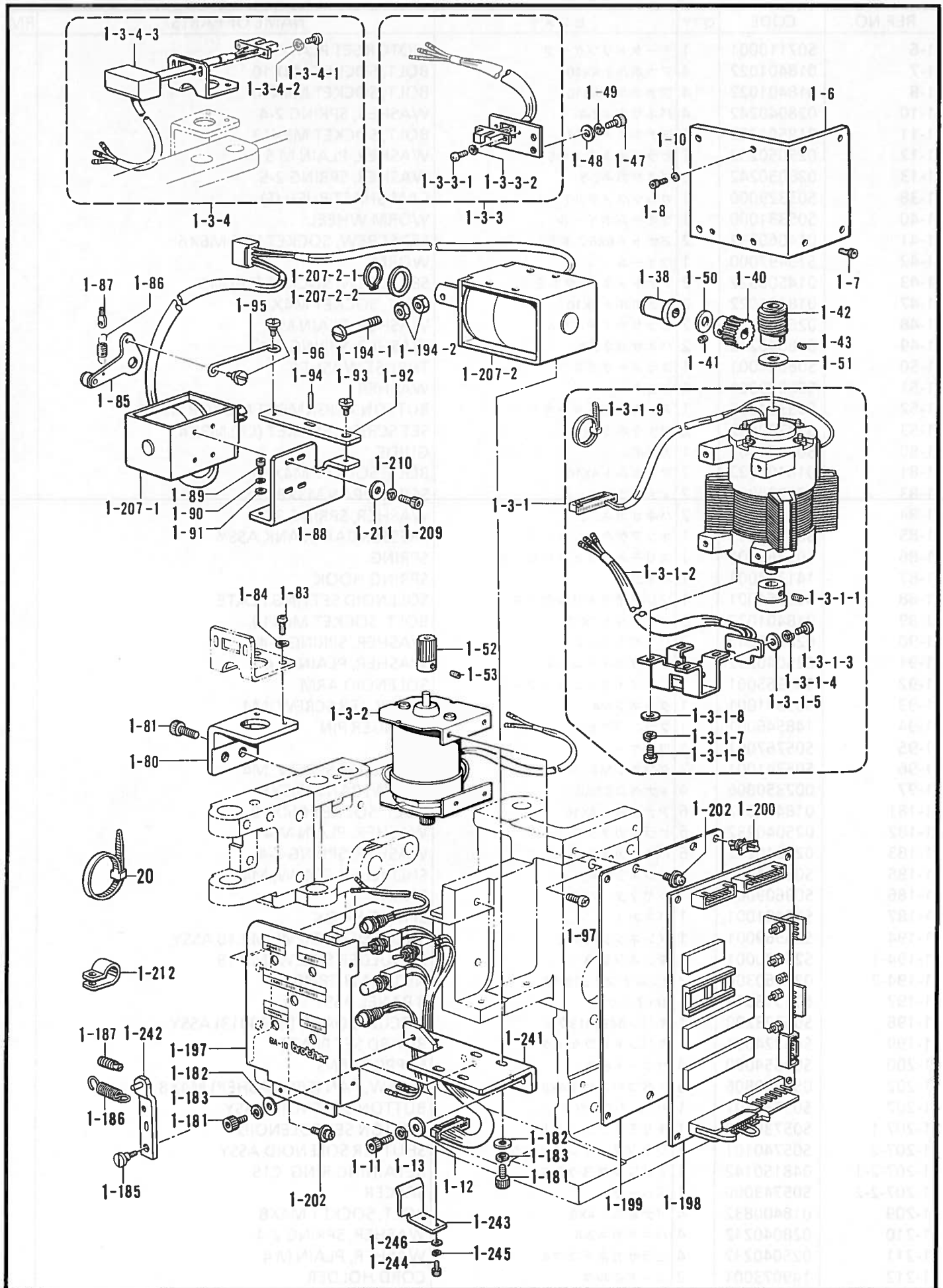

P2. ボタンフィーダー関係 / Button feeder mechanism / Knopzfuehrungvorrichtung /
Alimentation pour boutons / Botón de alimentación

REF.NO.	CODE	Q'TY	ヒンメイ	NAME OF PARTS	RM
1-241	S07069001	1	ソレノイドダイ	SOLENOID BASE	
1-242	S09581001	1	ウケイタイドウレバー	CATCH PLATE DRIVING LEVER	
1-243	S09579001	1	イドウレバーアテイタ	DRIVING LEVER STOPPER	
1-244	018400832	2	アナボルト4X8	BOLT, SOCKET M4X8	
1-245	028040242	2	バネザガネ2-4	WASHER, SPRING 2-4	
1-246	025040232	2	ヒラザガネチユウ4	WASHER, PLAIN M 4	
1-3	S07137101	1	Bモータークミ	(B) MOTOR ASSY	
1-3-1	S07136001	1	キヤリーモータークミ	CARRY MOTOR ASSY	
1-3-1-1	014300522	2	トメネジ3X5クボミ	SET SCREW, (CP) M3X5	
1-3-1-2	S05729001	1	カイテンセンサクミ	ROTATIONAL SENSOR ASSY	
1-3-1-3	002300603	2	+ナベコ3X6	SCREW, PAN M3X6	
1-3-1-4	028030243	2	バネザガネ2-3	WASHER, SPRING 2-3	
1-3-1-5	025030233	2	ヒラザガネチユウ3	WASHER, PLAIN M 3	
1-3-1-6	002300803	2	+ナベコ3X8	SCREW, PAN M3X8	
1-3-1-7	028030243	2	バネザガネ2-3	WASHER, SPRING 2-3	
1-3-1-8	025030233	2	ヒラザガネチユウ3	WASHER, PLAIN M 3	
1-3-1-9	S04557000	1	ハンタイPLTIM	BAND PLTIM	
1-3-2	S05730001	1	キリモミモータークミ	BUTTON SET MOTOR ASSY	
1-3-3	S05731001	1	ゲンテンSWクミ	HOME POSITION SWITCH ASSY	
1-3-3-1	002300803	2	+ナベコ3X8	SCREW, PAN M3X8	
1-3-3-2	028030243	2	バネザガネ2-3	WASHER, SPRING 2-3	
1-3-4	S05734001	1	キリモミSWクミ	BUTTON SWITCH ASSY	
1-3-4-1	002301003	2	+ナベコネジ3X10	SCREW, PAN M3X10	
1-3-4-2	028030243	2	バネザガネ2-3	WASHER, SPRING 2-3	
1-3-4-3	S05737000	1	センサカバー	SENSOR COVER	
20	S04557000	2	ハンタイPLTIM	BAND PLTIM	

P3. ボタンフィーダー関係 / Button feeder mechanism / Knopfzuführungvorrichtung /
Alimentation pour boutons / Botón de alimentación

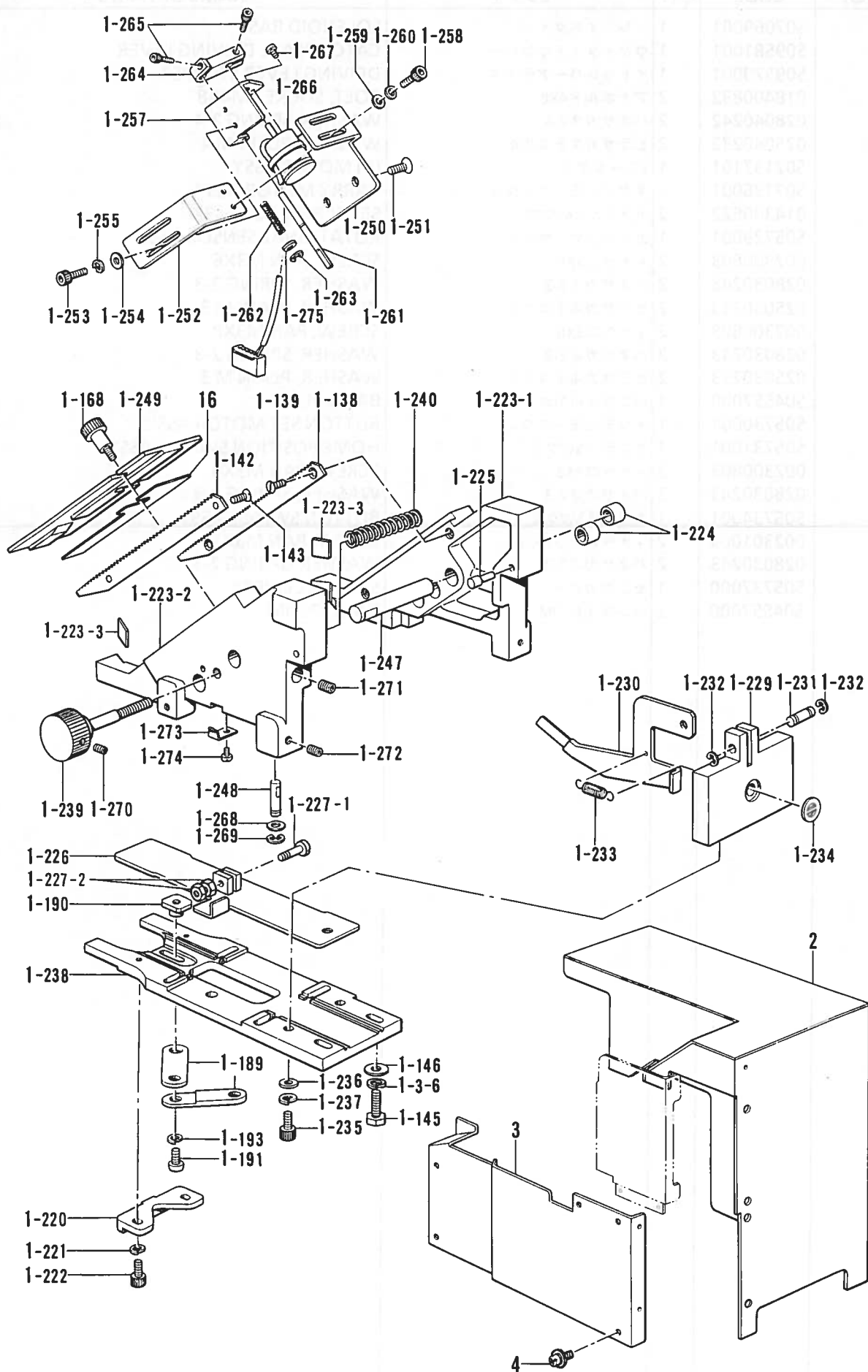

P3. ボタンフィーダー関係 / Button feeder mechanism / Knopfzuführungvorrichtung /
Alimentation pour boutons / Botón de alimentación

REF.NO.	CODE	Q'TY	ヒンメイ	NAME OF PARTS	RM
1-138	S05394001	1	ボタンスベリイタA	BUTTON SLIDE PLATE (A)	
1-139	S01696001	2	サラネジ3.57X6	SCREW, FLAT M3.57X6	
1-142	S05397001	1	ボタンスベリイタB	BUTTON SLIDE PLATE (B)	
1-143	S01696001	2	サラネジ3.57X6	SCREW, FLAT M3.57X6	
1-145	017501602	2	ボルト5X16	BOLT, M5X16	
1-146	140208001	2	ザガネ	WASHER	
1-168	S10512001	1	ツマミネジ3.57	SCREW, M3.57	
1-189	S05888001	2	スベリダイリンク	SLIDE BASE LINK	
1-190	S05889001	1	リンクシテン	LINK FUIRUM	
1-191	062400616	1	ナベコM4X6	SCREW, PAN M4X6	
1-193	028040242	1	バネザガネ2-4	WASHER, SPRING 2-4	
1-220	S09600001	1	ボタンウケダイストツバ	BUTTON CATCH BASE STOPPER	
1-221	028040242	2	バネザガネ2-4	WASHER, SPRING 2-4	
1-222	018401022	2	アナボルト4X10	BOLT, SOCKET M4X10	
1-223	S25117001	1	スベリダイクミ	SLIDE BASE ASSY	
1-223-1	S25118001	1	ボタンスベリダイA	BUTTON SLIDE BASE (A)	
1-223-2	S25119001	1	ボタンスベリダイB	BUTTON SLIDE BASE (B)	
1-223-3	S25120000	2	ハネカエリボウシゴム	RUBBER	
1-224	S09599000	4	スライドブツシュ	SLIDE BUSH	
1-225	S09591000	2	スベリダイストツバ	SLIDE BASE STOPPER	
1-226	S09582001	1	ボタンウケイタクミ	BUTTON CATCH PLATE ASSY	
1-227	S25571001	1	ダンネジ3クミ	SHOULDER SCREW, M3 ASSY	
1-227-1	S25572001	1	ダンネジ3	SHOULDER SCREW, M3	
1-227-2	021300202	2	2シユナツ3	NUT, 2 M3	
1-229	S09592001	1	ストツバササエ	STOPPER SUPPORT	
1-230	S09593001	1	ストツバA	STOPPER (A)	
1-231	S09587001	1	ストツバAササエジク	STOPPER (A) SUPPORT SHAFT	
1-232	048030342	2	トメワE3	RETAINING RING, E3	
1-233	S07091001	1	スライダーバネ	SPRING	
1-234	152877001	1	イトチヨウシサラオサエ	TENSION DISC WASHER	
1-235	018501622	2	アナボルト5X16	BOLT, SOCKET M5X16	
1-236	025050232	2	ヒラザガネチユウ5	WASHER, PLAIN M 5	
1-237	028050242	2	バネザガネ2-5	WASHER, SPRING 2-5	
1-238	S09594001	1	スベリダイシタダイ	SLIDE BASE LOWER BASE	
1-239	S09590001	1	スベリダイネジクミ	SLIDE BASE SCREW ASSY	
1-240	S09574001	1	スベリダイバネ	SPRING	
1-247	S09577001	2	スベリダイアンナジク	SLIDE BASE GUIDE SHAFT	
1-248	S09576001	4	スベリダイアンナジク	SLIDE BASE GUIDE SHAFT	
1-249	S09601100	1	ボタンウエカパーA	BUTTON UPPER COVER (A)	
1-250	S09584001	1	ソレノイドベース	SOLENOID BASE	
1-251	061500804	2	サラコ5X8	SCREW, FLAT M5X8	
1-252	S09585001	1	ソレノイドトリツケイタ	SOLENOID SETTING PLATE	
1-253	018400832	2	アナボルト4X8	BOLT, SOCKET M4X8	
1-254	025040232	2	ヒラザガネチユウ4	WASHER, PLAIN M 4	
1-255	028040242	2	バネザガネ2-4	WASHER, SPRING 2-4	
1-257	S09586001	1	ストツバジクササエイタ	STOPPER SHAFT SUPPORT PLATE	
1-258	018400832	2	アナボルト4X8	BOLT, SOCKET M4X8	
1-259	025040232	2	ヒラザガネチユウ4	WASHER, PLAIN M 4	
1-260	028040242	2	バネザガネ2-4	WASHER, SPRING 2-4	
1-261	S09575001	1	ストツバジク	STOPPER SHAFT	
1-262	S09573001	1	ストツババネ	SPRING	
1-263	048025342	1	トメワE2.5	RETAINING RING, E2.5	
1-264	S09572001	1	ストツバジクササエ	STOPPER SHAFT SUPPORT	
1-265	018300822	2	アナボルト3X8	BOLT, SOCKET M3X8	
1-266	S09611000	1	ストツパソレノイド	STOPPER SOLENOID	
1-267	062260406	2	ナベコ26X4	SCREW, PAN M2.6X4	
1-268	025050232	4	ヒラザガネチユウ5	WASHER, PLAIN M 5	
1-269	048030342	4	トメワE3	RETAINING RING, E3	
1-270	014500522	1	アナトメネジ5クボミ	SET SCREW, SOCKET (CP) M5	

P3. ボタンフィーダー関係 / Button feeder mechanism / Knopfzuführungvorrichtung /
 Alimentation pour boutons / Botón de alimentación

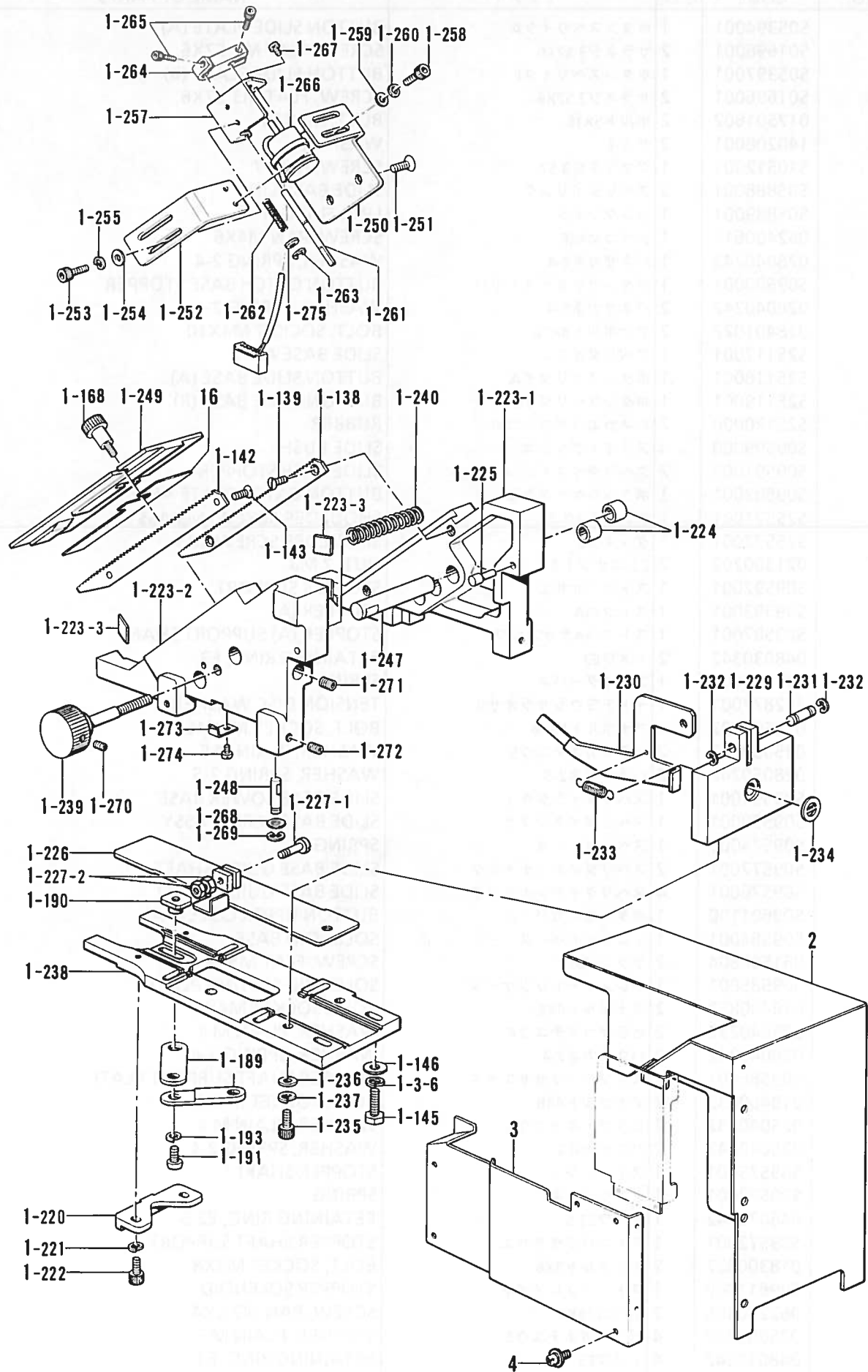

P3. ボタンフィーダー関係 / Button feeder mechanism / Knopzfuehrungsvorrichtung /
Alimentation pour boutons / Botón de alimentación

REF.NO.	CODE	Q'TY	ヒンメイ	NAME OF PARTS	RM
1-271	014060622	2	アナトメネジ6X6クボミ	SET SCREW, SOCKET (CP) M6X6	
1-272	014400522	4	アナクボミ4X5	SET SCREW, SOCKET (CP) M4X5	
1-273	S09613001	1	ツマミイタバネ	SPRING, PLATE	
1-274	062670512	1	ナベコ357-40X5	SCREW, PAN M3.57-40X5	
1-275	025350132	1	ヒラザガネシヨウ	WASHER, PLAIN S 3.5	
1-3-6	028050242	2	バネザガネ2-5	WASHER, SPRING 2-5	
2	S07060009	1	ホンタイカバークミ	MACHINE BODY COVER ASSY	
3	S10504009	1	マエカバー	FRONT COVER	
4	052400806	12	ナベコバネヒラ4X8	SCREW, PAN (S/P WASHER) M4X8	
5	025040232	11	ヒラザガネチユウ4	WASHER, PLAIN M 4	
21	028040243	12	バネザガネ2-4	WASHER, SPRING 2-4	
<補給用 / FOR SUPPLY>					
16	S13816000	1	スヘーサC (0.2mm)	SPACER (C) (0.2mm)	
16	S09604000	1	スヘーサA (0.4mm)	SPACER (A) (0.4mm)	
16	S09605000	1	スヘーサB (0.8mm)	SPACER (B) (0.8mm)	

Q. フィーダー関係 / Feeder mechanism / Knopfsortierer / Tricur de boutons /
Mecanismo de botones

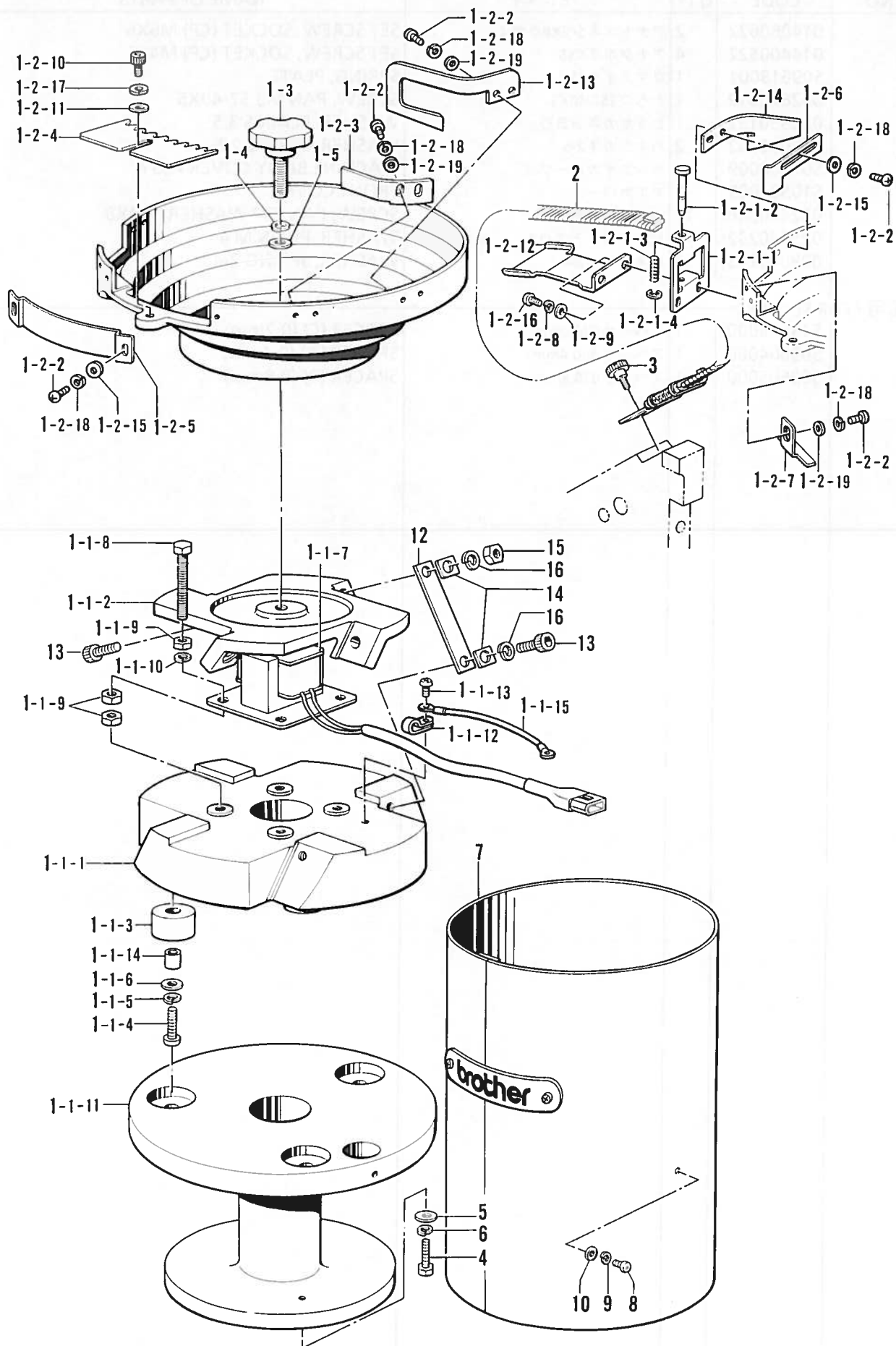

Q. フィーダー関係 / Feeder mechanism / Knopfsortierer / Tricur de boutons /
Mecanismo de botones

REF.NO.	CODE	Q'TY	ヒンメイ	NAME OF PARTS	RM
1	S05426209	1	シンドウボウルソウクミ	VIBRATION GENERATION BOWL UNIT	
1-1	S05427209	1	シンドウキクミ	VIBRATION GENERATION ASSY	
1-1-1	S08480001	1	シンドウキベースシタ	VIBRATION BASE LOWER	
1-1-2	S05912101	1	シンドウキベースウエ	VIBRATION BASE UPPER	
1-1-3	S05910000	3	クツシヨンゴム	CUSHION RUBBER	
1-1-4	002502505	3	+ナベコ5X25	SCREW, PAN M5X25	
1-1-5	028050242	3	バネザガネ2-5	WASHER, SPRING 2-5	
1-1-6	025050232	3	ヒラザガネチユウ5	WASHER, PLAIN M 5	
1-1-7	S05914101	1	シンドウソレノイド	VIBRATION GENERATION SOLENOID	
1-1-8	S08479001	4	ソレノイドササエボルト	BOLT	
1-1-9	021060202	12	2シユナツト 6	NUT, 2 M6	
1-1-10	028060242	8	バネザガネ2-6	WASHER, SPRING 2-6	
1-1-11	S05907109	1	ダイザ	BASE	
1-1-12	149547000	1	コードオサエ	CORD HOLDER (4N)	
1-1-13	062400806	1	ナベコ4X8	SCREW, PAN M4X8	
1-1-14	S06613001	3	クツシヨンカラー	CUSHION COLLAR	
1-1-15	S07985100	1	アースコードF	GROUND WIRE (F)	
1-2	S06027101	1	シンドウボウルクミ	VIBRATION GENERATION BOWL ASSY	
1-2-1	S05428001	1	クチガネクミ	CONNECTOR ASSY	
1-2-1-1	S05429001	1	クチガネ	CONNECTOR	
1-2-1-2	S05430001	1	シユータートメピン	PIN	
1-2-1-3	S05431001	1	トメピンオシバネ	SPRING	
1-2-1-4	048025342	1	トメワE2.5	RETAINING RING, E2.5	
1-2-2	002400802	9	+ナベネジ4X8	SCREW, PAN M4X8	
1-2-3	S07163001	1	セイレツイタA	ALIGNMENT PLATE (A)	
1-2-4	S05433000	1	ヒヨウリセンベツイタ	SORTING PLATE	
1-2-5	S05435001	1	センベツバンクチフタ	SORTING COVER	
1-2-6	S07166001	1	ボタンハバチヨウセツイタ	BUTTON WIDTH CONTROL PLATE	
1-2-7	S07165001	1	タカサチヨウセツイタ	HEIGHT CONTROL PLATE	
1-2-8	028040242	2	バネザガネ2-4	WASHER, SPRING 2-4	
1-2-9	025040233	2	ヒラザガネチユウ4	WASHER, PLAIN M 4	
1-2-10	018501422	1	アナボルト5X14	BOLT, SOCKET M5X14	
1-2-11	025050232	1	ヒラザガネチユウ5	WASHER, PLAIN M 5	
1-2-12	S06022001	1	シユータークoilササエ	SHOOTER COIL SUPPORT	
1-2-13	S07164001	1	セイレツイタB	ALIGNMENT PLATE (B)	
1-2-14	S07167001	1	セイレツイタC	ALIGNMENT PLATE (C)	
1-2-15	025040332	4	ヒラザガネダイ4	WASHER, PLAIN L 4	
1-2-16	062401006	2	ナベコ4X10	SCREW, PAN M4X10	
1-2-17	028050242	1	バネザガネ2-5	WASHER, SPRING 2-5	
1-2-18	028040242	9	バネザガネ2-4	WASHER, SPRING 2-4	
1-2-19	025040232	5	ヒラザガネチユウ4	WASHER, PLAIN M 4	
1-3	S05438100	1	ボウルシメネジ	SCREW	
1-4	028080242	1	バネザガネ2-8	WASHER, SPRING 2-8	
1-5	025080336	1	ヒラザガネダイ8	WASHER, PLAIN L 8	
2	S07042001	1	シユートコイルクミ	SHOOT COIL ASSY	
3	S06441001	1	ツマミネジ3.57	SCREW 3.57	
4	144543001	2	ボルト6X63	BOLT, M6X63	
5	115947001	2	ザガネ	WASHER	
6	028060242	2	バネザガネ2-6	WASHER, SPRING 2-6	
7	S06130009	1	フィダーカバークミ	BUTTON SORTER COVER ASSY	
8	018501022	3	アナボルト5X10	BOLT, SOCKET M5X10	
9	028050242	3	バネザガネ2-5	WASHER, SPRING 2-5	
10	025050232	3	ヒラザガネチユウ5	WASHER, PLAIN M 5	
12	S06033001	4	イタバネ0.8(50HZ用)	SPRING, PLATE 0.8 (FOR 50HZ)	
12	S06034001	4	イタバネ1.0(60HZ用)	SPRING, PLATE 1.0 (FOR 60HZ)	
13	018082522	8	アナボルト8X25	BOLT, SOCKET M8X25	
14	S05917001	8	ザガネ	WASHER	
15	021080102	4	ナツト1シユ8	NUT, 1 M8	
16	028080242	8	バネザガネ2-8	WASHER, SPRING 2-8	

R. コントロールボックス関係 / Control box mechanism / Schaltkasten /
 Mécanisme du boîtier de contrôle / Mecanismo de la caja de controles

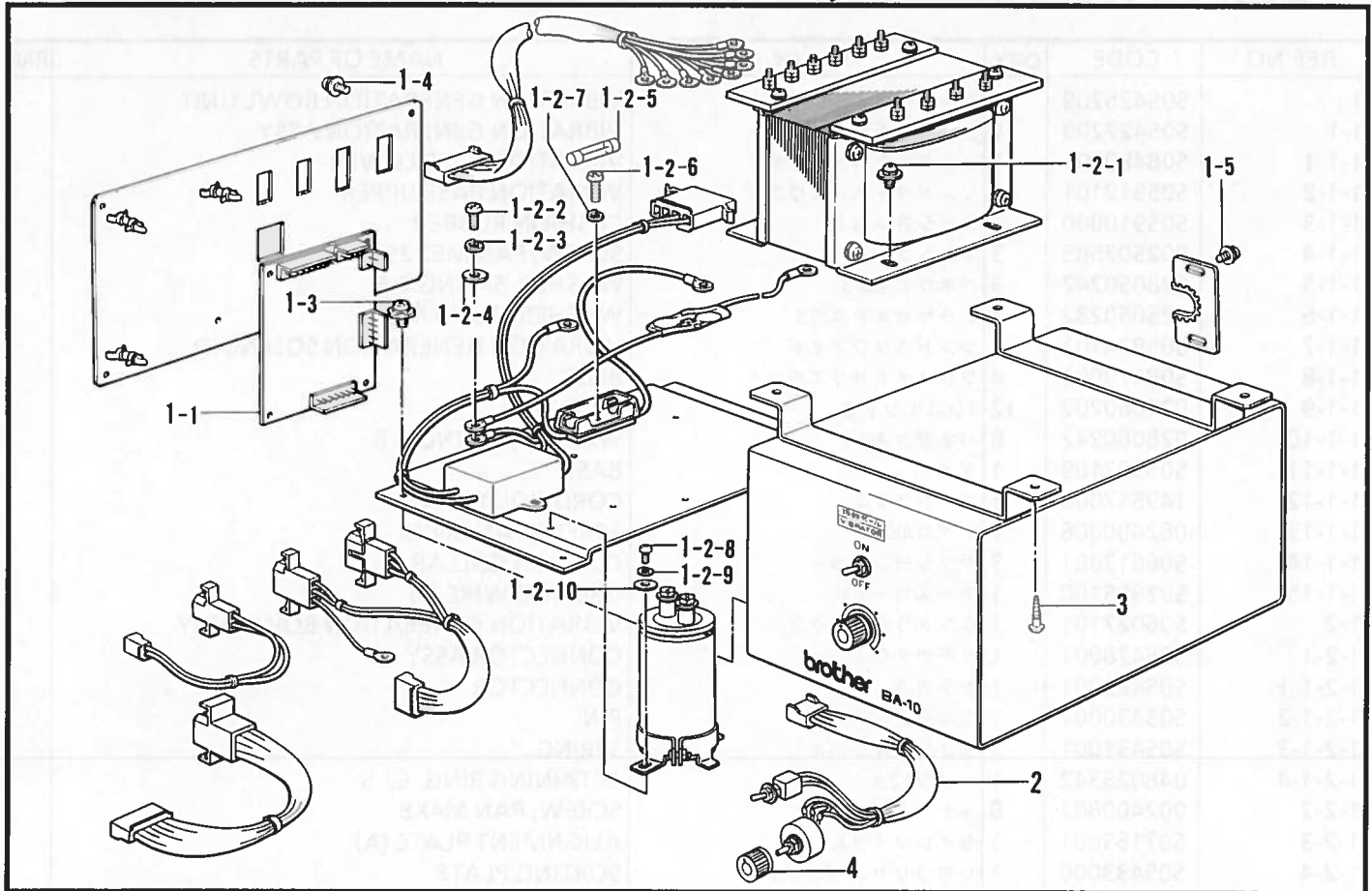

151-910-502

S. ボタン検知関係 / Button detector mechanism / Knopfdetektor / Détecteur de bouton /
 Detector de botones

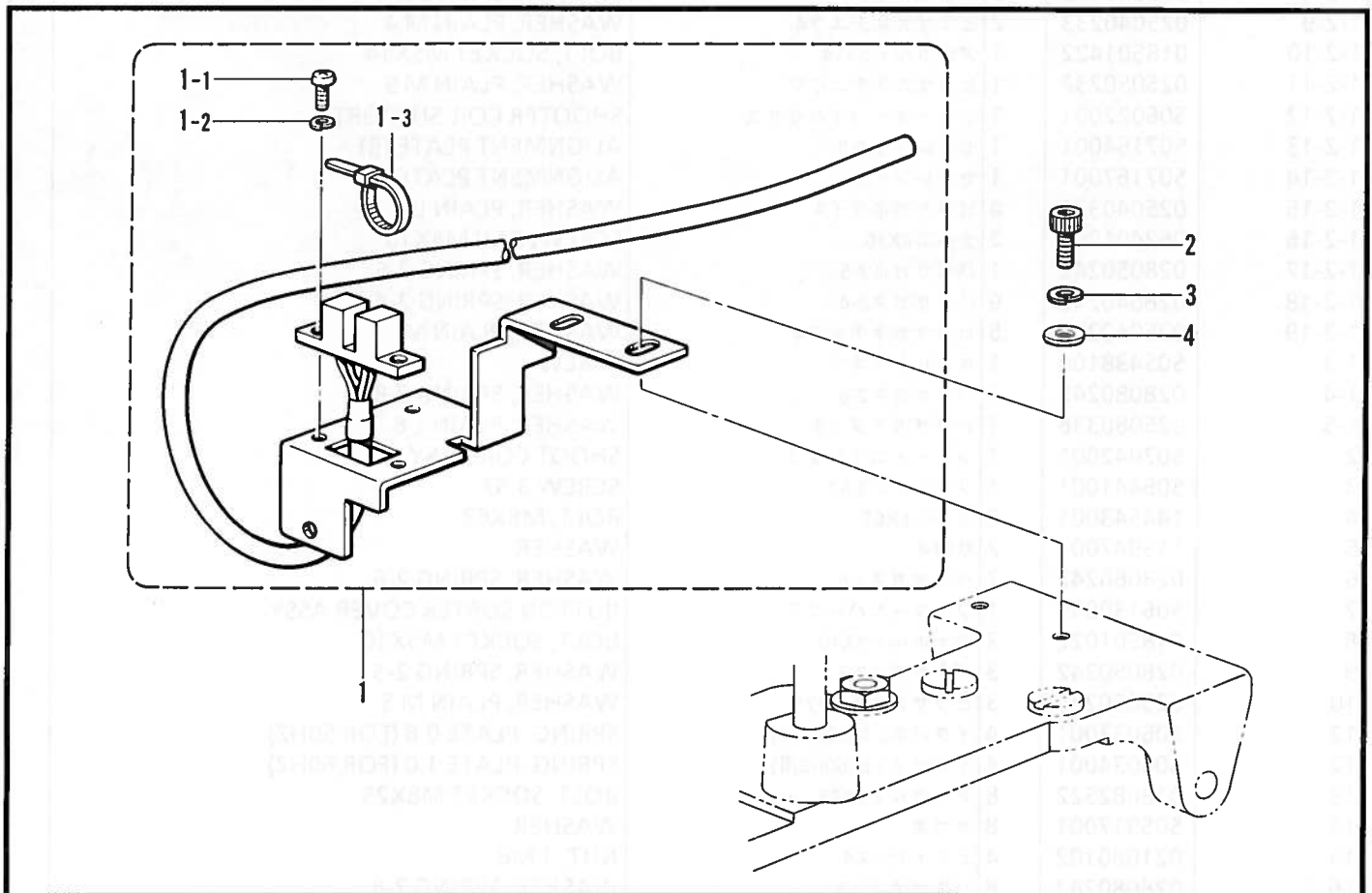

151-910-520

R. コントロールボックス関係 / Control box mechanism / Schaltkasten /
Mécanisme du boîtier de contrôle / Mecanismo de la caja de controles

REF.NO.	CODE	Q'TY	ヒンメイ	NAME OF PARTS	RM
1	S16111309	1	ボックスクミ	BOX ASSY	
1-1	S05475200	1	キバンB438021クミ	CIRCUIT BOARD (B438021) ASSY	
1-2-1	052400806	4	ナベコバネヒラ4X8	SCREW, PAN (S/P WASHER) M4X8	
1-2-2	002300803	2	+ナベコ3X8	SCREW, PAN M3X8	
1-2-3	028030243	2	バネザガネ2-3	WASHER, SPRING 2-3	
1-2-4	025030232	2	ヒラザガネチユウ3	WASHER, PLAIN M 3	
1-2-5	215769001	1	カンヒューズ3A	FUSE 3A	
1-2-6	002401403	1	+ナベコ4X14	SCREW, PAN M4X14	
1-2-7	028040243	1	バネザガネ2-4	WASHER, SPRING 2-4	
1-2-8	002300803	2	+ナベコ3X8	SCREW, PAN M3X8	
1-2-9	028030243	2	バネザガネ2-3	WASHER, SPRING 2-3	
1-2-10	025030233	2	ヒラザガネチユウ3	WASHER, PLAIN M 3	
1-3	052400806	4	ナベコバネヒラ4X8	SCREW, PAN (S/P WASHER) M4X8	
1-4	052400806	4	ナベコバネヒラ4X8	SCREW, PAN (S/P WASHER) M4X8	
1-5	052400806	2	ナベコバネヒラ4X8	SCREW, PAN (S/P WASHER) M4X8	
2	S05484000	1	ケーブルDクミ	CABLE (D) ASSY	
3	032452502	4	+マルモクネジ4.5X25	WOOD SCREW, ROUND M4.5X25	
4	S02907000	1	ツマミ	DIAL	

151-910-502

S. ボタン検知関係 / Button detector mechanism / Knopfdetektor / Détecteur de bouton /
Detector de botones

REF.NO.	CODE	Q'TY	ヒンメイ	NAME OF PARTS	RM
1	S05458201	1	Bケンチセンサクミ	BUTTON DETECTOR SENSOR ASSY	
1-1	002300803	2	+ナベコ3X8	SCREW, PAN M3X8	
1-2	028030243	2	バネザガネ2-3	WASHER, SPRING 2-3	
1-3	S04557000	2	バンタイPLTIM	BAND PLTIM	
2	018400832	2	アナボルト4X8	BOLT, SOCKET M4X8	
3	028040242	2	バネザガネ2-4	WASHER, SPRING 2-4	
4	025040232	2	ヒラザガネチユウ4	WASHER, PLAIN M 4	

151-910-520

T. 電装品関係 / Power supply equipment mechanism / Stromversorgung /
 Mécanisme de l'équipement en alimentation électrique /
 Mecanismo del equipo de alimentación de corriente

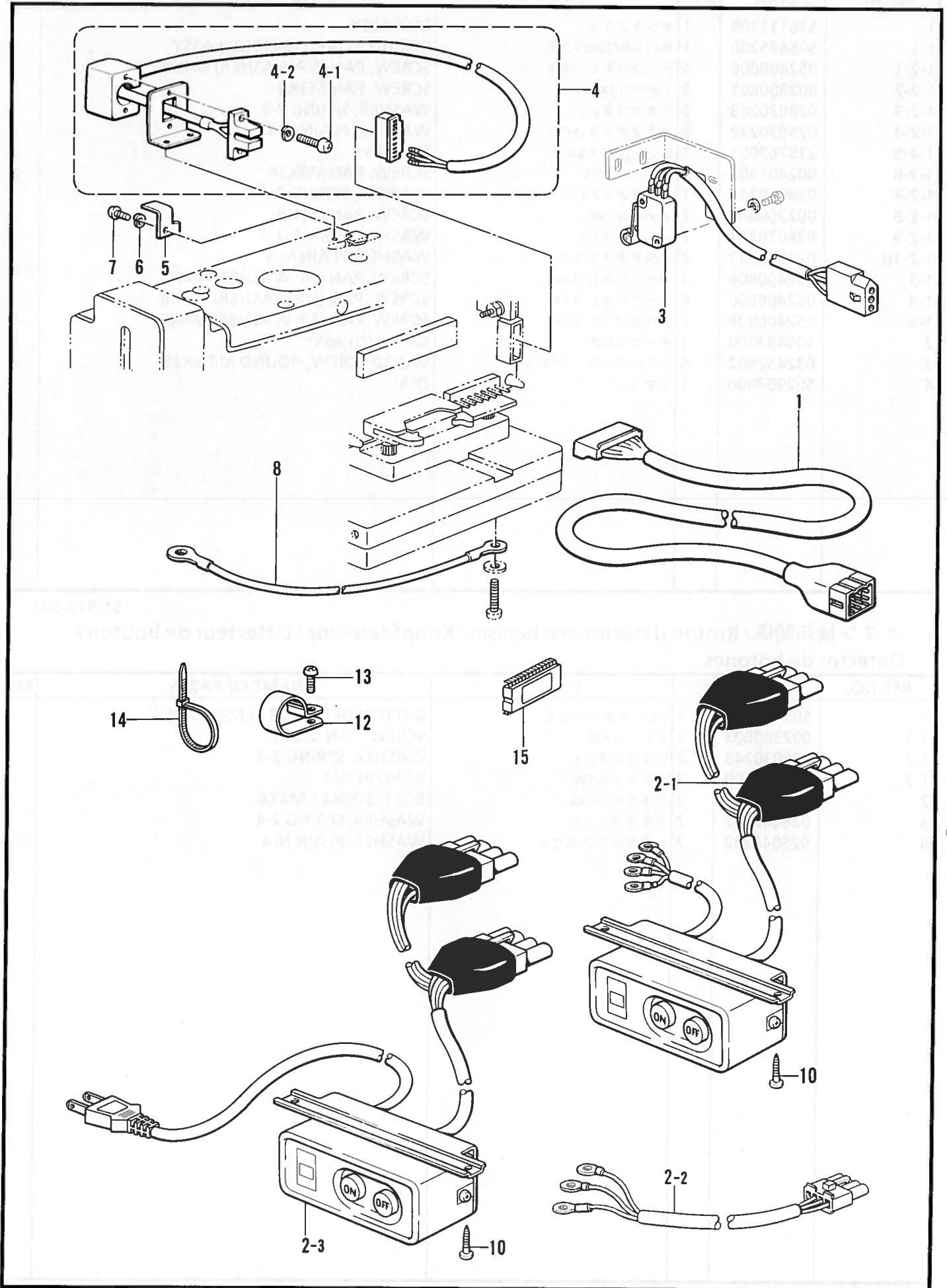

T. 電装品関係 / Power supply equipment mechanism / Stromversorgung /
 Mécanisme de l'équipement en alimentation électrique /
 Mecanismo del equipo de alimentación de corriente

REF.NO.	CODE	Q'TY	ヒンメイ	NAME OF PARTS	RM
1	S05485000	1	Bレンケツケーブルクミ	B CONNECTION CABLE ASSY	
3	S05488000	1	スタートSWクミ	START SWITCH ASSY	
4	S05744001	1	ミシンテイシSWクミ	SEWING MACHINE SWITCH ASSY	
4-1	002301003	2	+ナベコネジ3X10	SCREW, PAN M3X10	
4-2	028030243	2	バネザガネ2-3	WASHER, SPRING 2-3	
5	S05747001	1	テイシセンサーシキリイタ	STOP DEVICE SENSOR PARTITION PLATE	
6	028030243	1	バネザガネ2-3	WASHER, SPRING 2-3	
7	062300605	1	ナベコ3X6	SCREW, PAN M3X6	
8	S05992100	2	アースコードA	GROUND WIRE (A)	
10	032452502	2	+マルモクネジ4.5X25	WOOD SCREW, ROUND M4.5X25	
12	552907000	2	コードホルダ#10	CORD HOLDER (10N)	
13	062711012	1	ナベコ476-32X10	SCREW, PAN M4.76-32X10	
14	S04557000	6	バンタイPLTIM	BAND PLTIM	
15	S16234000	1	PROM910Aトククミ	PROM 910A ASSY	
<200V>					
2-1	S05486109	1	デンゲンコードクミA	-----	
<220V, 380V, 415V>					
2-2	S06252100	1	-----	POWER SUPPLY CABLE ASSY	
<100V>					
2-3	S07039109	1	デンゲンコードクミB	POWER SUPPLY CABLE ASSY (B)	

U. オプションパーツ / Option parts / Sondezubehör / Pièces en option / Piezas opcionales

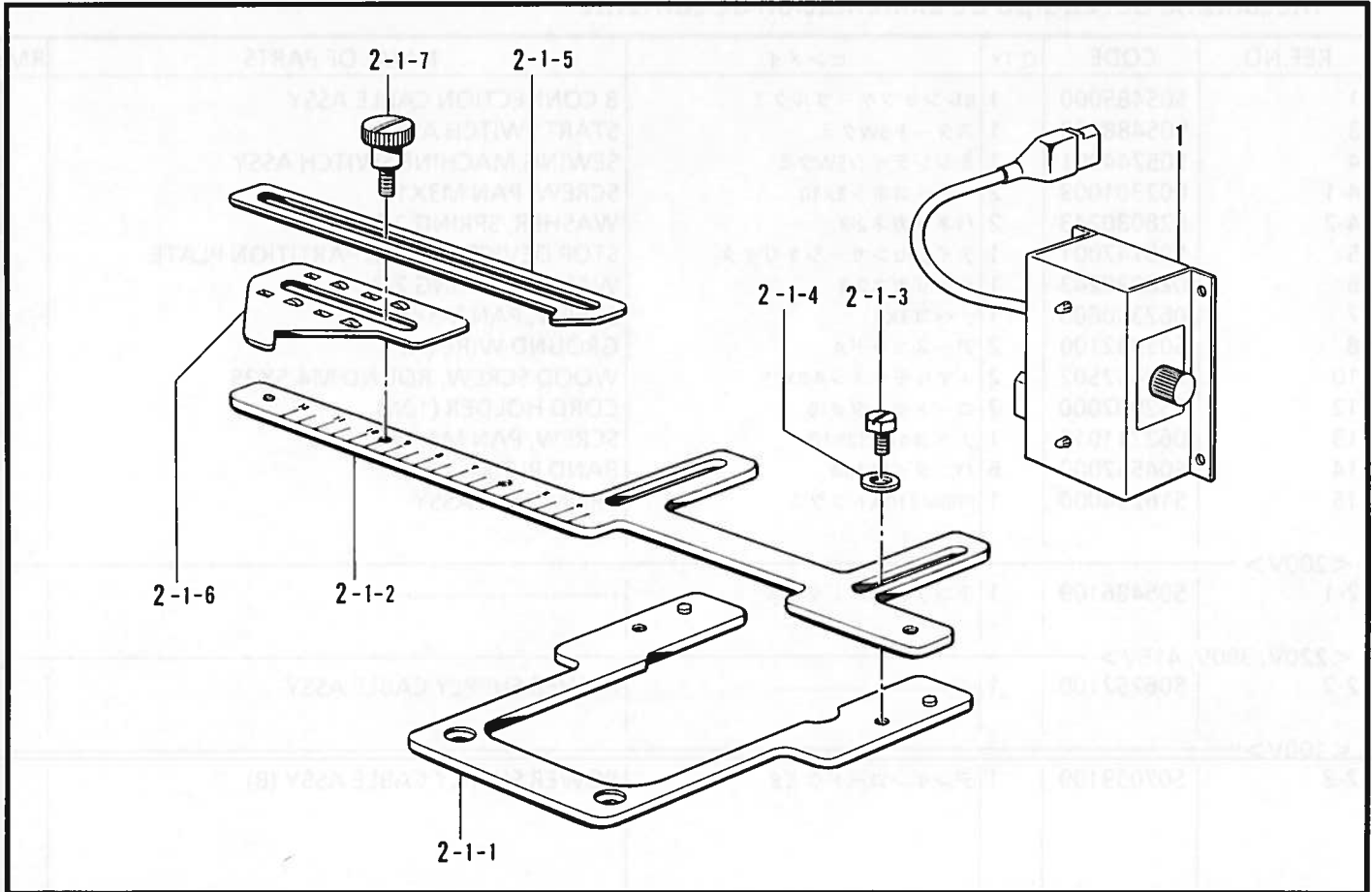

118-917-940

Z1. 付属品関係 (オプションパーツ) / Accessories (Option parts) / Zubehör (Sondezubehör) / Accessoires (Pièces en option) / Accesorios (Piezas opcionales)

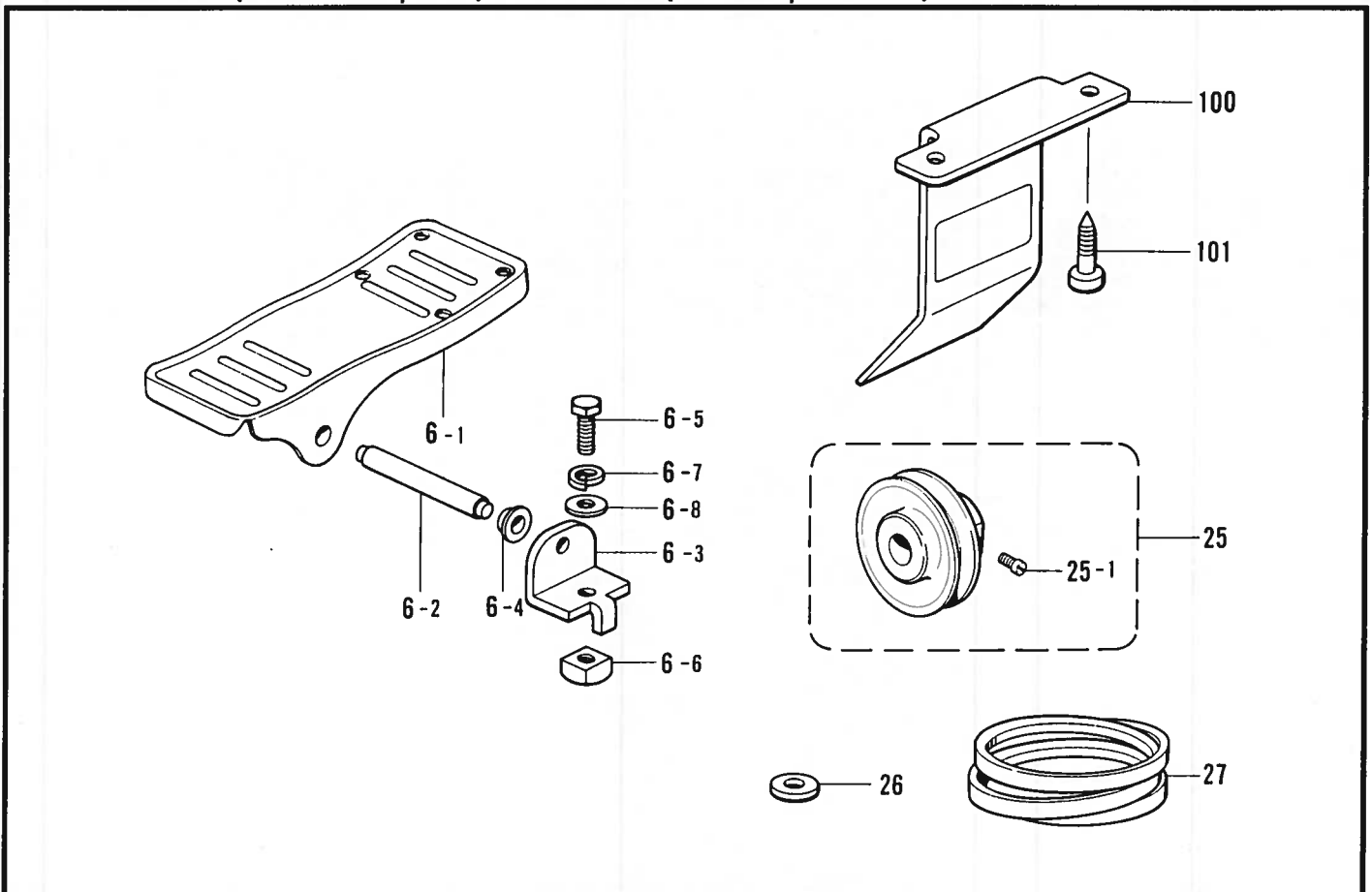

118-917-910

U. オプションパーツ / Option parts / Sondezubehör / Pièces en option / Piezas opcionales

REF.NO.	CODE	Q'TY	ヒンメイ	NAME OF PARTS	RM
1	S06282009	1	レンゾクキドウクミ	CONTINUOUS STARTING ASSY	
2	S09655001	1	ボタンスペーサーセット	BUTTON SPACER SET	
2-1	S09656001	1	ボタンスペーサークミ	BUTTON SPACER ASSY	
2-1-1	S09657001	1	ドダイ	BASE	
2-1-2	S09658001	1	スケール	SCALE	
2-1-3	S09686001	2	ボルト4.37-40X7	BOLT, M4.37-40X7	
2-1-4	S02745001	2	ザガネ	WASHER	
2-1-5	S09659001	1	イチギメイタA	POSITIONING SET PLATE (A)	
2-1-6	S09660001	1	イチギメイタB	POSITIONING SET PLATE (B)	
2-1-7	115166001	1	ダンネジ4.37	SHOULDER SCREW, M4.37	

118-917-940

Z1. 付属品関係(オプションパーツ) / Accessories (Option parts) / Zubehör (Sondezubehör) / Accessoires (Pièces en option) / Accesorios (Piezas opcionales)

REF.NO.	CODE	Q'TY	ヒンメイ	NAME OF PARTS	RM
6	S01603009	1	オサエアゲフミイタクミ(Z脚用)	TREADLE ASSY (FOR Z-TYPE STAND)	
6-1	S01199003	1	オサエアゲフミイタ	TREADLE PEDAL	
6-2	133188001	1	オサエアゲフミイタジク	TREADLE SHAFT	
6-3	119707003	2	フミイタジクウケ	TREADLE SHAFT BRACKET	
6-4	119708001	2	フミイタジクウケカラー	TREADLE SHAFT BRACKET COLLAR	
6-5	017082206	2	ボルト8X22	BOLT, M8X22	
6-6	116694001	2	4カクナツト8	NUT, M8	
6-7	028080240	2	バネザガネ2-8	WASHER, SPRING 2-8	
6-8	025080236	2	ヒラザガネチユウ8	WASHER, PLAIN M 8	
25	119270001	1	N65プーリークミ(60HZ用)	N65 PULLEY ASSY (FOR 60HZ)	
25	119271001	1	N75プーリークミ(50HZ用)	N75 PULLEY ASSY (FOR 50HZ)	
25-1	105730001	2	アタマツキトメネジ5.95	SET SCREW, M6.35	
26	133824001	8	モータークツシヨン	CUSHION RUBBER	
27	S18707124	1	VベルトMシロ(50HZ用)	V-BELT M (WHITE) (FOR 50HZ)	
27	S18707123	1	VベルトMシロ(60HZ用)	V-BELT M (WHITE) (FOR 60HZ)	
100	S38636001	1	プーリカバークミ	PULLEY COVER ASSY	
101	032422003	2	マルモクネジ4.1X20	WOOD SCREW, M4.0X20	

118-917-910

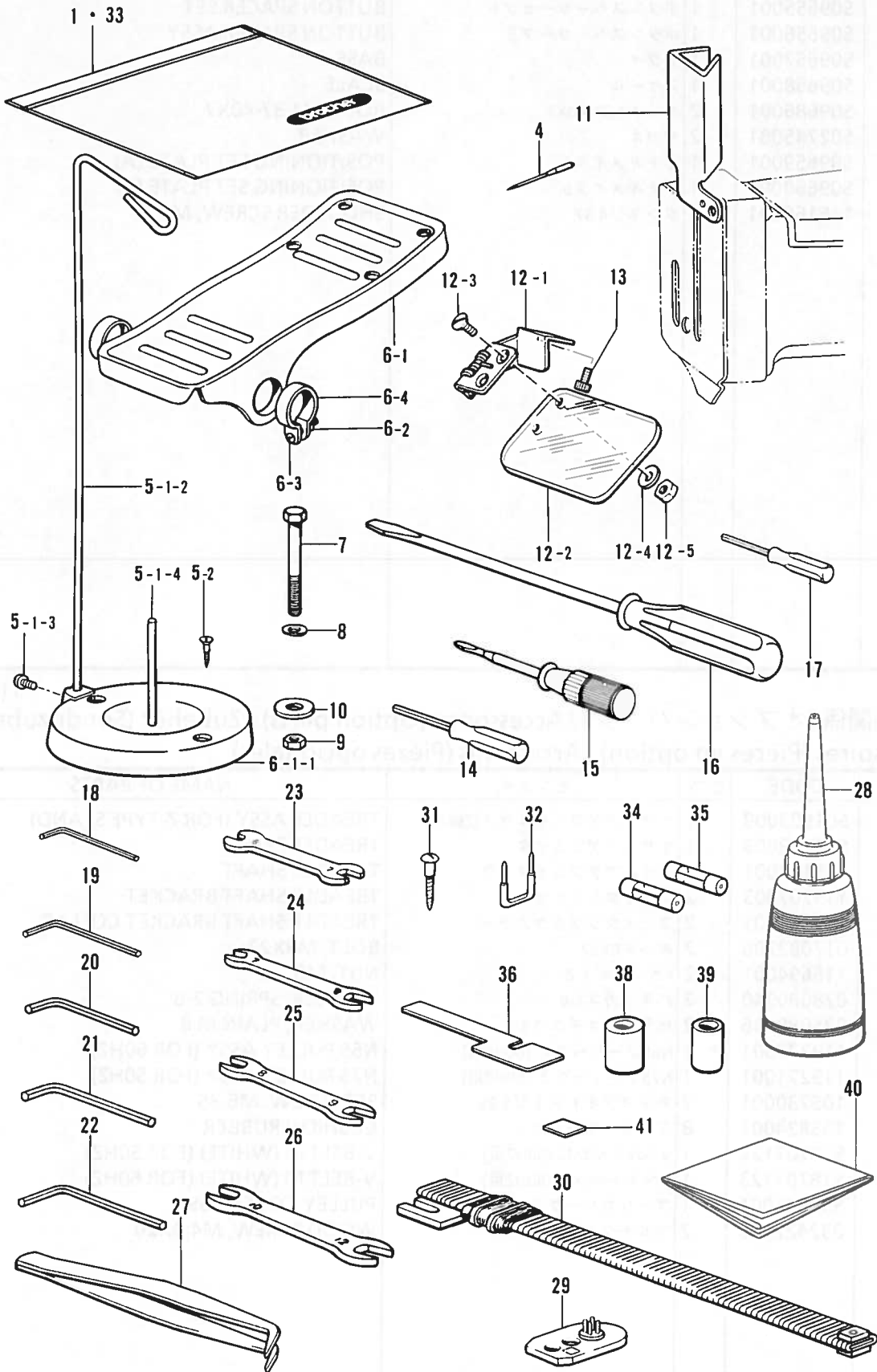

- ◎ 付属品の明細は変更することがあります。
- ◎ The details of included accessories are subject to change.
- ◎ Änderungen in der Aufstellung der Mitgelieferten Zubehöre sind vorbehalten.
- ◎ Les détails des accessoires inclus sont sujets à des changements.
- ◎ Los detalles de los accesorios incluidos pueden variar.

Z2. 付属品関係 / Accessories / Zubehör / Accessoires / Accesorios

REF.NO.	CODE	Q'TY	ヒンメイ	NAME OF PARTS	RM
1	122991001	1	フゾクヒンポリフクロ	ACCESSORY BAG	
4	115053014	2	ミシンハリTQX1 (#14)	NEEDLE TQX1 (#14)	
4	115053016	2	ミシンハリTQX1 (#16)	NEEDLE TQX1 (#16)	
4	115053018	2	ミシンハリTQX1 (#18)	NEEDLE TQX1 (#18)	
5	S20130009	1	イトタテダイクミネジツキ	COTTON STAND WITH SCREW	
5-1	S20131009	1	イトタテダイクミ	COTTON STAND ASSY	
5-1-1	S20132009	1	イトタテサラ	DISC	
5-1-2	S20133001	1	イトカケ	THREAD GUIDE	
5-1-3	S20134001	1	シメネジW476-24X10	SCREW W476-24X10	
5-1-4	S20135001	1	イトタテボウ	SPOOL PIN	
5-2	034422006	2	+2サラモク4.1X20	WOOD SCREW, FLAT M4.1X20	
6	116185209	1	ヘタルクミ	PEDAL ASSY	
6-1	117437109	1	オサエアゲフミイタ	FOOT LIFTER PEDAL	
6-2	021400106	2	ナツト1シユ4	NUT, 1 M4	
6-3	062401416	2	ナベコ4X14	SCREW, PAN M4X14	
6-4	116016001	2	ヘタルトメ	PEDAL STOPPER	
7	144543001	4	ボルト6X63	BOLT, M6X63	
8	025060232	4	ヒラザガネチユウ6	WASHER, PLAIN M 6	
9	021060102	4	ナツト1シユ6	NUT, 1 M6	
10	115947001	4	ザガネ	WASHER	
11	S37135001	1	ハリボウカバー	NEEDLE BAR COVER	
12	S37137001	1	アイガードクミ	EYE GUARD ASSY	
12-1	S37132001	1	アイガードチヨウバンクミ	EYE GUARD HINGE ASSY	
12-2	143966001	1	アイガード	EYE GUARD	
12-3	S01700001	2	マルサラネジ3.18X7	SCREW, FLAT M3.18X7	
12-4	025030232	2	ヒラザガネチユウ3	WASHER, PLAIN M 3	
12-5	021660102	2	ナツト1シユ3.18	NUT, 1 M3.18	
13	018400632	1	アナボルト4X6	BOLT, SOCKET M4X6	
14	142443001	1	ネジマワシ1.9X52	SCREW DRIVER 1.9X52	
15	118837001	1	ネジマワシ3.4X70	SCREW DRIVER 3.4X70	
16	101572101	1	ネジマワシ5.5X190	SCREW DRIVER 5.5X190	
17	S01943001	1	6カクボウネジマワシ1.6	SCREW DRIVER 1.6	
18	S01860001	1	6カクボウスパナ2	HEXAGONAL WRENCH 2	
19	154125001	1	6カクボウスパナ2.5	HEXAGONAL WRENCH 2.5	
20	142721001	1	6カクボウスパナ3	HEXAGONAL WRENCH 3	
21	118064001	1	6カクボウスパナ4	HEXAGONAL WRENCH 4	
22	150335001	1	6カクボウスパナ5	HEXAGONAL WRENCH 5	
23	107779001	1	スパナ6X7	SPANNER 6X7	
24	142205001	1	スパナ7X8	WRENCH 7X8	
25	100887001	1	スパナ8X9	WRENCH 8X9	
26	107780001	1	スパナ10X12	WRENCH 10X12	
28	114483002	1	ポリオイルークミ	OILER ASSY	
29	S06687003	1	ボタンウケダイクミWS	BUTTON CATCH PLATE ASSY (WS)	
30	S07042002	1	シユートコイルクミ	SHOOT COIL ASSY	
31	032452502	2	+マルモクネジ4.5X25	WOOD SCREW, ROUND M4.5X25	
32	200190001	6	ステツプル	STAPLE	
33	122991001	1	フゾクヒンポリフクロ	ACCESSORY BAG	
34	215769001	2	カンヒューズ3A	FUSE (3A)	
35	153242000	1	ヒューズ6A	FUSE (6A)	
36	S09604000	2	スペーサA	SPACER (A)	
36	S09605000	1	スペーサB	SPACER (B)	
38	S06620001	1	ゲージ	GAUGE	
39	S05356000	1	ボタンオサエA	BUTTON PRESSER (A)	
39	S06569000	1	ボタンオサエB	BUTTON PRESSER (B)	
39	S09351000	1	ボタンオサエD	BUTTON PRESSER (D)	
39	S09352000	1	ボタンオサエE	BUTTON PRESSER (E)	
40	S09357001	1	テーブルシート	TABLE SHEET	
41	S25120000	10	ハネカエリボウシゴム	RUBBER	

ゲージパーツリスト(補給部品) / Gauge parts list (supply parts) /
 Lehrenliste (liefereteile) / Liste des pieces d'ecartement (pieces fournies) /
 Lista de piezas calibradoras (piezas de suministro)

ボタンウケダイクミ

Button Catch Plate Assembly

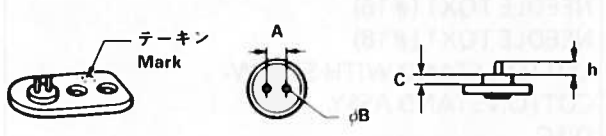

テーキン Mark	A (mm)	φB (mm)	C (mm)	h (mm)	部品コード Parts. No.
A	3.2	1.2	4	3.5	S19005001
C	2.6	1.0	2.5	4	S06686001
D	2.8	1.2	2.5	4	S06686002
E	3.0	1.2	2.5	4	S06686003
F	3.2	1.2	2.5	4	★S06686004
G	3.4	1.2	2.5	4	S06686005
H	3.6	1.2	2.5	4	S06686006
J	3.8	1.2	2.5	4	S06686007
K	3.2	1.5	2.5	4	S06686008
L	3.4	1.5	2.5	4	S06686009
M	3.6	1.5	2.5	4	S06686010
N	3.8	1.5	2.5	4	S06686011

ボタンウケダイクミW

Button Catch Plate Assembly W

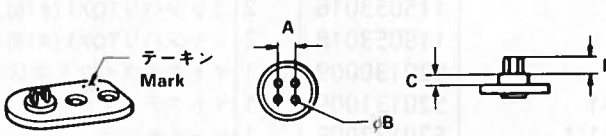

テーキン Mark	A (mm)	φB (mm)	C (mm)	h (mm)	部品コード Parts. No.
A	2.6	1.2	4	3.5	S19007001
D	2.2	1.0	2.5	4	S06687001
E	2.4	1.0	2.5	4	S06687002
F	2.6	1.2	2.5	4	S06687003
G	2.8	1.2	2.5	4	S06687004
H	3.0	1.2	2.5	4	S06687005
J	3.2	1.2	2.5	4	S06708001
K	3.4	1.5	2.5	4	S06708002
L	3.6	1.5	2.5	4	S06708003
M	3.2	1.5	2.5	4	S06708004

ボタンオサエ

Button Presser

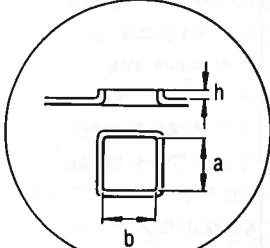

S05356000	S06569000	★S06570000	S09351000	
付属品(A) Accessory (A)	標準(B) Standard (B)	標準(C) Standard (C)	付属品(D) Accessory (D)	
φ8	φ8	φ8	φ10	
S09352000	S09353000	S09354000	S09355000	S09356000
付属品(E) Accessory (E)	オプション(F) Option(F)	オプション(G) Option(G)	オプション(H) Option(H)	オプション(J) Option(J)
φ10	φ12	φ12	φ16	φ16

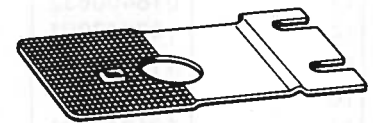
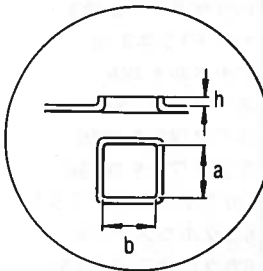

品名 Name of Parts	部品コード Parts No.	a b h
送り板A Feed Plate A	S03476101	4.8X4.8X0.8(標準用)
送り板B Feed Plate B	S03630101	4.8X4.8X0(凹型ボタン用)
送り板C Feed Plate C	115085001	7 X7 X0(大ピッチ用)
送り板D Feed Plate D	S03632101	7 X7 X0.8
送り板E Feed Plate E	S16121101	8 X2 X0(ラベル付け用)

ゲージ
Gauge

S06620001

★印の部品は、標準部品です。

The ★ symbol is for standard parts.

Mit dem Zeichen ★ standardteile bezeichnet.

Le symbole ★ correspond aux pièces normales.

El asterisco ★ es para piezas normales.

ボタンウエカバー
Button Upper Cover

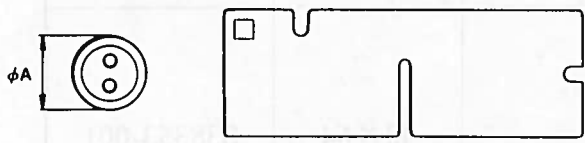

テーキン Mark	φA(mm)	部品コード Parts. No.
A	9 ~ 12	★ S09601100
B	12 ~ 16	S09602100
C	16 ~ 22	S09603100

スペーサ
Spacer

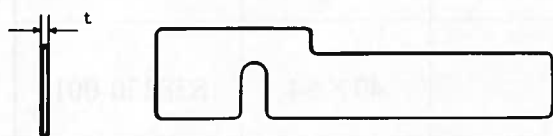

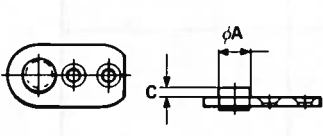

テーキン Mark	t (mm)	部品コード Parts. No.
A	0.4	S09604000
B	0.8	S09605000
C	0.2	S13186000

ボタンウケダイブランク
Button Catch Plate Blank

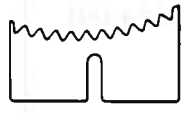
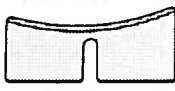
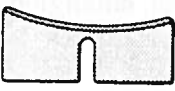

φA (mm)	C (mm)	部品コード Parts. No.
6	2.5	S06133001
8.5	2.5	S06710001

ヒョウリセンベツイタ
Sorting Plate

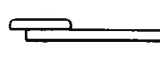
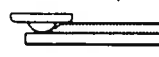
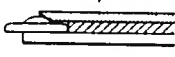
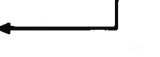
★ S05433000	(U) S06814000	(UB) S06816000	(M) S06815000
			
			

★印の部品は、標準部品です。

The ★ symbol is for standard parts.
Mit dem Zeichen ★ standardteile bezeichnet.
Le symbole ★ correspond aux pièces normales.
El asterisco ★ es para piezas normales.

シュートコイルクミ
Shoot Coil Assembly

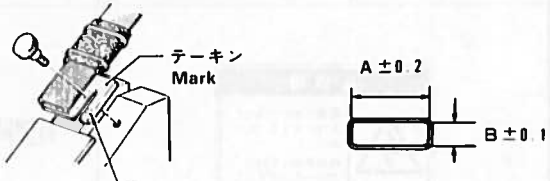



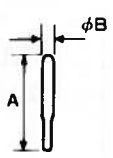

テーキン Mark	A(mm)×B(mm)	部品コード Parts. No.
A	15 × 2.7	★ S07042001
B	17 × 3.5	S07042002
C	25 × 4.0	S07042003
D	13 × 2.5	S07042004
E	13 × 3.0	S07042005
F	15 × 3.2	S07042006
G	15 × 3.8	S07042007
H	17 × 4.0	S07042008
J	18 × 4.5	S07042009
K	20 × 3.5	S07042010
L	20 × 4.0	S07042011
M	21 × 4.5	S07042012
N	22 × 5.7	S07042013
P	25 × 4.7	S07042014
Q	13 × 2.0	S07042015
R	22 × 2.0	S07042016
S	17 × 2.7	S07042017
T	17 × 2.2	S07042018
U	20 × 2.7	S07042019



ボタンウケピン
Pin

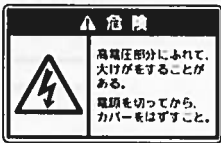

A(mm)	φB(mm)	部品コード Parts. No.
9	1.0	S06688001
9	1.2	S06689001
9	1.5	S06690001

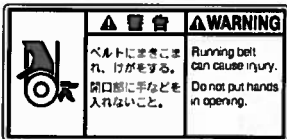
警告ラベル／Warning labels／Warnschilder／
Etiquettes d'avertissement／Etiquetas de advertencia

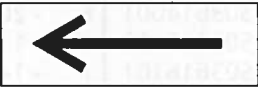
	品名／Name of parts	Size(mm)	Code
	電撃ラベル・和	40×64	S38353-001
	Label, elec. shock 4 lang.	35×118	S38352-001
	操作注意ラベル・和	40×64	S38350-001
		52×84	S38350-002
	Label, operation Eng.	40×64	S38349-001
		52×84	S38349-002
	高温ラベル Label, high temp.	72×59	S38351-001
	巻き込み注意ラベル Label, entanglement	40×84	S38354-001

	品名/Name of parts	Size(mm)	Code
	ワーニングマーク Mark, injury	L=16 R=0.8	S36924-001
	矢印マーク Mark, arrow	10×30	S37058-001
	PEマーク Mark, PE	7.5×12.5	S37059-001
	アースマーク Mark, grounding	$\phi 12$	S37060-001

索引/INDEX/VERZEICHIS/
INDEX/INDICE

CODE	REF.NO.	Page
S00554000	P2 - 1-200	28
S01199003	Z1 - 6-1	42
S01603009	Z1 - 6	42
S01696001	K - 2	18
	P3 - 1-139	32
	P3 - 1-143	32
S01700001	Z2 - 12-3	44
S01702001	D - 15	6
S01860001	Z2 - 18	44
S01943001	Z2 - 17	44
S02582001	N - 1-1	22
S02592009	N - 1-19	22
S02745001	N - 1-9-6	22
	U - 2-1-4	42
S02907000	R - 4	38
S03374109	A - 12	2
S03376001	A - 18	2
S03377101	J - 12-1	16
S03378000	C - 2	4
S03379101	C - 4	4
S03381101	C - 8	4
S03382101	C - 8-1	4
S03383001	C - 8-2	4
S03384001	C - 8-3	4
S03385000	C - 8-4	4
S03386001	C - 8-5	4
S03387001	C - 8-7	4
S03388001	C - 8-11	4
S03392001	C - 11-2	4
S03393001	C - 11-6	4
S03394001	C - 11-7	4
S03395000	C - 11-9	4
S03401001	C - 11-16	4
	P2 - 1-187	28
S03402001	C - 12	4
S03403001	C - 15	4
S03405101	C - 16-1	4
S03406101	H - 1-2	14
S03407001	C - 16-3	4
	H - 1-3	14
S03408001	C - 16-4	4
	H - 1-4	14
S03409001	D - 1	6
S03410001	D - 1-1	6
S03412000	D - 1-1-1-2	6
S03414001	D - 1-1-3	6
S03415001	D - 1-2	6
S03417000	D - 1-3	6
S03418000	D - 1-4	6
S03419001	D - 2	6
S03420001	D - 3	6
S03421001	D - 5	6
S03424000	D - 7	6
S03425000	D - 8	6
S03426101	D - 11	6
S03427101	D - 11-1	6
S03428001	D - 11-2	6
S03429101	D - 12	6
S03433001	B - 1-2	2
S03436001	B - 2	2
S03437001	B - 4	2
S03438001	B - 5	2
S03439001	B - 6	2

CODE	REF.NO.	Page
S03440001	B - 7	2
S03441001	B - 8	2
S03442001	B - 9	2
S03444000	E - 2	8
S03445001	E - 5	10
S03446001	E - 6	10
S03448001	E - 6	10
S03451001	E - 7	8
S03459001	E - 44-2	8
S03464101	E - 44-5-1	8
S03468001	E - 44-5-11	10
S03471001	E - 10	8
S03472001	E - 11	8
S03473001	E - 12	8
S03474001	E - 13	8
S03476101	E - 23	8
S03478101	E - 26	8
S03480001	E - 28	8
S03482101	E - 30	8
S03484101	E - 30-1	8
S03485001	E - 34	8
S03486001	E - 36	8
S03488001	F - 1	12
S03489101	F - 2	12
S03490001	F - 5	12
S03496101	F - 6-2	12
S03500001	F - 8	12
S03501000	F - 8-1	12
S03502001	F - 8-2	12
S03503001	F - 8-3	12
	F - 13	12
S03504001	F - 8-5	12
S03508001	F - 8-6	12
S03509001	F - 9	12
S03512001	F - 17	12
S03517101	F - 20-2	12
S03518001	F - 20-9	12
S03519001	F - 23	12
S03520001	F - 23-1	12
S03521001	F - 24	12
S03522001	G - 1	14
S03523101	G - 2	14
S03524000	G - 3	14
S03525000	G - 4	14
S03526001	G - 5	14
S03528001	G - 9	14
S03533001	G - 13	14
S03536001	G - 15	14
S03538109	J - 1-1	16
S03540001	J - 1-3	16
S03541001	J - 1-4	16
S03542001	J - 1-5	16
S03543101	J - 1-8	16
S03544101	J - 1-10	16
S03545001	J - 1-10-1	16
S03546001	J - 1-10-2	16
S03549001	J - 1-15	16
S03550001	J - 1-15-1	16
S03551001	J - 1-17	16
S03556001	J - 1-18	16
S03557001	J - 1-19	16
S03558001	J - 1-20	16
S03560001	J - 10	16

CODE	REF.NO.	Page
S03561201	J - 12	16
S03564001	J - 13	16
S03565001	J - 14	16
S03566001	J - 15	16
S03567001	K - 1	18
S03600001	E - 44-9	10
S03605001	E - 44-11	10
S03606001	E - 44-14	10
S03607001	E - 44-15	10
S03608001	E - 44-16	10
S03610001	E - 44-5-13	10
S03611001	E - 37	8
S03613001	F - 20-3	12
S03614001	F - 20-6	12
S03615109	J - 1	16
S03616101	J - 1-2	16
S03617001	J - 3	16
S03621001	H - 1-8	14
S03622101	H - 1-9	14
S03623001	H - 1-10	14
S03624001	H - 4	14
S03626001	H - 6	14
S03627001	H - 7	14
S03628001	H - 8	14
S03629001	H - 9	14
S03651001	E - 5	10
S03653001	G - 9	14
S03657001	E - 44-5-12	10
S03695001	E - 44-3	8
S03704002	F - 11	12
S03719001	D - 1-1-1	6
S03720001	D - 1-1-2	6
S04557000	S - 1-3	38
	T - 14	40
	P2 - 1-3-1-9	30
	P2 - 20	30
S05312001	P1 - 1-2	24
S05318009	P2 - 1-197	28
S05323200	P2 - 1-198	28
S05324001	P2 - 1-199	28
S05329000	P2 - 1-38	28
S05330000	P1 - 1-39	24
S05331000	P2 - 1-40	28
S05333001	P1 - 1-44	24
S05334000	P2 - 1-52	28
S05335001	P1 - 1-54	24
S05336001	P1 - 1-118	26
S05337000	P1 - 1-55	24
S05338000	P1 - 1-57	24
S05339001	P1 - 1-58	24
S05340001	P1 - 1-60	24
S05341001	P1 - 1-61	24
	P1 - 1-107	26
	P2 - 1-93	28
	P2 - 1-96	28
S05342001	P1 - 1-62	24
S05343000	P1 - 1-63	24
S05344000	P1 - 1-65	24
S05345001	P1 - 1-66	24
S05356000	Z2 - 39	44
S05359001	P2 - 1-85	28
S05363001	P2 - 1-86	28
S05364001	P2 - 1-88	28

CODE	REF.NO.	Page
S05365001	P2 - 1-92	28
S05368101	P1 - 1-99	26
S05369001	P1 - 1-101	26
S05370001	P1 - 1-102	26
S05371001	P1 - 1-22	24
	P1 - 1-106	26
S05373001	P1 - 1-113	26
S05374001	P1 - 1-136	26
S05375001	P1 - 1-120	26
S05376001	P1 - 1-122	26
S05378000	P1 - 1-1-1-1	24
S05379000	P1 - 1-1-1-2	24
S05380101	P1 - 1-127	26
S05384001	P1 - 1-17	24
S05385000	P1 - 1-19	24
S05386001	P1 - 1-20	24
S05387001	P1 - 1-21	24
S05388001	P1 - 1-23	24
S05389001	P1 - 1-25	24
S05390001	P1 - 1-26	24
S05391001	P1 - 1-31	24
S05392001	N - 1-15	22
S05394001	P3 - 1-138	32
S05397001	P3 - 1-142	32
S05424001	P2 - 1-185	28
S05426209	Q - 1	36
S05427209	Q - 1-1	36
S05428001	Q - 1-2-1	36
S05429001	Q - 1-2-1-1	36
S05430001	Q - 1-2-1-2	36
S05431001	Q - 1-2-1-3	36
S05433000	Q - 1-2-4	36
S05435001	Q - 1-2-5	36
S05438100	Q - 1-3	36
S05444009	L - 1-1	18
S05448009	L - 1-2	18
S05449009	L - 1-3	18
S05450001	L - 1-10	18
S05451001	L - 1-11	18
S05452001	L - 1-12	18
S05455001	L - 1-17	18
S05458201	S - 1	38
S05462009	N - 1	22
S05463009	N - 1-9	22
S05464009	N - 1-6	22
S05466001	N - 1-13	22
S05467001	N - 1-14	22
S05468001	N - 2	22
S05469001	N - 3	22
S05470001	N - 6	22
S05475200	R - 1-1	38
S05484000	R - 2	38
S05485000	T - 1	40
S05486109	T - 2-1	40
S05488000	T - 3	40
S05674001	F - 8	12
S05676001	F - 20	12
S05678101	E - 44-5-4	8
S05679101	E - 44-5-2	8
S05680101	E - 44-5-3	8
S05681101	E - 44-5-5	8
S05682001	F - 8-2	12
S05683001	F - 20-11	12

CODE	REF.NO.	Page
S05685109	A - 10-2	2
S05687001	E - 44-5-10	10
S05689001	E - 44-5	8
S05690009	M - 1	20
S05691009	M - 1-1	20
S05695009	M - 1-2	20
S05696001	M - 1-11	20
S05709001	F - 20-1	12
S05712001	E - 44-10	10
S05724001	B - 10	2
S05725001	C - 8-8	4
S05729001	P2 - 1-3-1-2	30
S05730001	P2 - 1-3-2	30
S05731001	P2 - 1-3-3	30
S05734001	P2 - 1-3-4	30
S05737000	P2 - 1-3-4-3	30
S05738101	P2 - 1-207	28
S05739000	P2 - 1-207-1	28
S05740101	P2 - 1-207-2	28
S05743000	P2 - 1-207-2-2	28
S05744001	T - 4	40
S05747001	T - 5	40
S05767001	P2 - 1-95	28
S05881001	N - 9	22
S05882001	N - 12	22
S05883001	N - 13	22
S05884000	N - 17	22
S05885001	N - 21	22
S05888001	P3 - 1-189	32
S05889001	P3 - 1-190	32
S05905001	E - 44-5-14	10
S05906009	M - 1-14	20
S05907109	Q - 1-1-11	36
S05910000	Q - 1-1-3	36
S05912101	Q - 1-1-2	36
S05914101	Q - 1-1-7	36
S05917001	Q - 14	36
S05972000	P1 - 1-98	26
S05973001	N - 26	22
S05974001	N - 1-3	22
S05989001	N - 27	22
S05992100	T - 8	40
S06022001	Q - 1-2-12	36
S06024001	P2 - 1-50	28
S06027101	Q - 1-2	36
S06029001	P2 - 1-51	28
S06033001	Q - 12	36
S06034001	Q - 12	36
S06044001	P1 - 1-129	26
S06057001	J - 1-12	16
S06119001	P1 - 1-134	26
S06130009	Q - 7	36
S06137001	D - 6	6
S06152001	N - 1-22	22
S06252100	T - 2-2	40
S06253201	J - 1-21	16
S06282009	U - 1	42
S06432001	J - 1-15-4	16
S06441001	Q - 3	36
S06466001	L - 1-18	18
S06569000	Z2 - 39	44
S06570000	P1 - 1-79	26
S06613001	Q - 1-1-14	36

CODE	REF.NO.	Page
S06620001	Z2 - 38	44
S06686004	P1 - 1-3-5	26
S06687003	Z2 - 29	44
S06713000	A - 11	2
S07039109	T - 2-3	40
S07042001	Q - 2	36
S07042002	Z2 - 30	44
S07060009	P3 - 2	34
S07063001	P1 - 1-1-1-3	24
S07064001	P1 - 1-1-3	24
S07066001	P1 - 1-1-1	24
S07068001	P1 - 1-1	24
S07069001	P2 - 1-241	30
S07070001	P1 - 1-37	24
S07074001	P2 - 1-80	28
S07091001	P3 - 1-233	32
S07110001	P2 - 1-6	28
S07128001	P1 - 1-124	26
S07129001	P1 - 1-125	26
S07136001	P2 - 1-3-1	30
S07137101	P2 - 1-3	30
S07163001	Q - 1-2-3	36
S07164001	Q - 1-2-13	36
S07165001	Q - 1-2-7	36
S07166001	Q - 1-2-6	36
S07167001	Q - 1-2-14	36
S07985100	Q - 1-1-15	36
S07995001	A - 10-5	2
S08479001	Q - 1-1-8	36
S08480001	Q - 1-1-1	36
S09043000	E - 67	10
S09351000	Z2 - 39	44
S09352000	Z2 - 39	44
S09357001	Z2 - 40	44
S09362001	F - 20	12
S09572001	P3 - 1-264	32
S09573001	P3 - 1-262	32
S09574001	P3 - 1-240	32
S09575001	P3 - 1-261	32
S09576001	P3 - 1-248	32
S09577001	P3 - 1-247	32
S09579001	P2 - 1-243	30
S09581001	P2 - 1-242	30
S09582001	P3 - 1-226	32
S09584001	P3 - 1-250	32
S09585001	P3 - 1-252	32
S09586001	P3 - 1-257	32
S09587001	P3 - 1-231	32
S09590001	P3 - 1-239	32
S09591000	P3 - 1-225	32
S09592001	P3 - 1-229	32
S09593001	P3 - 1-230	32
S09594001	P3 - 1-238	32
S09599000	P3 - 1-224	32
S09600001	P3 - 1-220	32
S09601100	P3 - 1-249	32
S09604000	P3 - 16	34
	Z2 - 36	44
S09605000	P3 - 16	34
	Z2 - 36	44
S09609001	P2 - 1-186	28
S09611000	P3 - 1-266	32
S09613001	P3 - 1-273	34

CODE	REF.NO.	Page
S09655001	U -2	42
S09656001	U -2-1	42
S09657001	U -2-1-1	42
S09658001	U -2-1-2	42
S09659001	U -2-1-5	42
S09660001	U -2-1-6	42
S09686001	U -2-1-3	42
S10504009	P3 -3	34
S10512001	P3 -1-168	32
S10667001	E -25	8
S10668001	C -9	4
	G -7	14
S10701001	P1 -1-68	24
S10703000	P1 -1-69	24
S10704001	P1 -1-75	24
S10705000	P1 -1-73	24
S10706000	P1 -1-74	24
S10707001	P1 -1-77	24
S10708001	P1 -1-76	24
S10709001	P1 -1-72	24
S11081001	L -1-15	18
S11147009	L -1	18
S12415001	P1 -1-130	26
S13816000	P3 -16	34
S15497000	P2 -1-42	28
S16111309	R -1	38
S16234000	T -15	40
S16253001	J -1-23	16
S18707123	Z1 -27	42
S18707124	Z1 -27	42
S20130009	Z2 -5	44
S20131009	Z2 -5-1	44
S20132009	Z2 -5-1-1	44
S20133001	Z2 -5-1-2	44
S20134001	Z2 -5-1-3	44
S20135001	Z2 -5-1-4	44
S20740101	C -25	4
S25116009	P1 -1	24
S25117001	P3 -1-223	32
S25118001	P3 -1-223-1	32
S25119001	P3 -1-223-2	32
S25120000	P3 -1-223-3	32
	Z2 -41	44
S25569001	P2 -1-194	28
S25570001	P2 -1-194-1	28
S25571001	P3 -1-227	32
S25572001	P3 -1-227-1	32
S31024001	N -1-4	22
S31723001	E -29	8
S31724001	E -27	8
S34278001	H -1-6	14
S34298001	H -5	14
S34340001	C -4-3	4
S34341001	C -4-1	4
S34806001	C -11-10	4
S35727001	C -17	4
S36592009	A -10	2
S36593000	A -10-1	2
S36615001	C -11	4
S36616001	C -11-1	4
S36617001	H -1-1	14
S36622001	D -14	6
S36624001	K -3	18

CODE	REF.NO.	Page
S36625001	K -4	18
S36626001	E -8	8
S36629001	F -6	12
S36630001	F -6-1	12
S36633001	F -15	12
S36642001	C -21	4
S36693001	C -11-11	4
S36694001	C -16	4
S36695001	C -16-2	4
S36696001	B -1	2
S36697001	B -1	2
S36699001	G -16	14
S36700001	C -28	4
S36816001	A -10-8	2
S37132001	Z2 -12-1	44
S37133001	C -23	4
S37135001	Z2 -11	44
S37137001	Z2 -12	44
S37175000	E -42	8
S37352009	E -44-1	8
S37362001	C -18	4
S37369001	H -1	14
S37434009	E -44	8
S37439000	F -70	12
S37444001	E -9	8
S38636001	Z1 -100	42
S39092000	E -69	10
S39974001	G -11-1	14
002300502	P1 -1-71	24
002300603	P2 -1-3-1-3	30
002300803	R -1-2-2	38
	R -1-2-8	38
	S -1-1	38
	P2 -1-3-1-6	30
	P2 -1-3-3-1	30
	P2 -1-83	28
002301003	N -1-9-4	22
	T -4-1	40
	P2 -1-3-4-1	30
002350806	P2 -1-97	28
002400663	N -1-9-7	22
002400802	Q -1-2-2	36
002401402	N -18	22
002401403	R -1-2-6	38
002502505	Q -1-1-4	36
013710512	F -5-1	12
013710712	F -19	12
	J -1-9	16
	J -1-11	16
	J -11	16
013750512	G -16-2	14
013760712	C -3	4
	E -4	8
014060622	P1 -1-126	26
	P3 -1-271	34
014060632	N -1-16	22
	P1 -1-18	24
	P1 -1-34	24
	P1 -1-45	24
	P1 -1-100	26
	P1 -1-105	26
	P1 -1-123	26
	P1 -1-128	26

CODE	REF.NO.	Page
014060632	P2 -1-41	28
014300432	P1 -1-56	24
	P1 -1-59	24
	P1 -1-70	24
	P2 -1-53	28
014300522	P2 -1-3-1-1	30
014400522	L -1-13	18
	P1 -1-78	24
	P3 -1-272	34
014500522	P1 -1-24	24
	P1 -1-28	24
	P1 -1-64	24
	P1 -1-67	24
	P2 -1-43	28
	P3 -1-270	32
014680622	E -44-8	10
	F -8-4	12
	F -8-8	12
	J -1-22	16
014710522	C -22	4
014760622	C -24	4
	D -4	6
	E -33	8
	E -35	8
	E -38	8
	E -44-17	10
	F -4	12
	F -10	12
	F -20-10	12
	H -1-7	14
	P1 -1-135	26
014770622	B -9-1	2
	D -1-1-1-4	6
	D -5-1	6
	E -5-1	10
	E -5-1	10
	E -6-1	10
	E -6-1	10
	E -7-1	8
	F -1-1	12
	F -11-1	12
	G -1-1	14
	G -5-1	14
	G -9-1	14
	G -9-1	14
014821022	B -1-1	2
	C -8-13	4
015770812	D -1-1-1-3	6
017062003	P1 -1-3	24
017082206	Z1 -6-5	42
017400602	L -1-16	18
017501602	P3 -1-145	32
017711412	E -44-6	10
018061022	E -44-4	8
018061622	M -2	20
018062022	C -16-6	4
	F -21	12
	P1 -1-1-2	24
018065022	P1 -6	26
018082522	Q -13	36
018300822	P3 -1-265	32
018400632	L -1-6	18
	M -1-15	20

CODE	REF.NO.	Page
018400632	Z2 - 13	44
018400832	L - 1-4	18
	M - 1-3	20
	N - 1-10	22
	N - 1-20	22
	S - 2	38
	P2 - 1-209	28
	P2 - 1-244	30
	P3 - 1-253	32
	P3 - 1-258	32
018401022	L - 1-14	18
	N - 22	22
	P2 - 1-7	28
	P2 - 1-8	28
	P2 - 1-47	28
	P2 - 1-81	28
	P2 - 1-89	28
	P2 - 1-181	28
	P3 - 1-222	32
018501022	N - 1-24	22
	N - 14	22
	Q - 8	36
018501222	P2 - 1-11	28
018501422	Q - 1-2-10	36
018501622	P3 - 1-235	32
018680822	F - 6-3	12
021060102	N - 1-7	22
	Z2 - 9	44
021060106	P1 - 1-131	26
021060202	Q - 1-1-9	36
021080102	Q - 15	36
021080302	N - 1-2	22
021300103	L - 1-1-2	18
	P1 - 1-27	24
	P1 - 1-30	24
021300202	P3 - 1-227-2	32
021400106	Z2 - 6-2	44
021400202	P1 - 1-108	26
	P1 - 1-114	26
021660102	Z2 - 12-5	44
021660306	P2 - 1-194-2	28
021670202	M - 1-13	20
021710102	E - 14	8
021750112	A - 10-5-4	2
	C - 8-10	4
021800102	C - 11-14	4
	D - 1-1-4	6
025030132	L - 1-1-3	18
025030232	R - 1-2-4	38
	P1 - 1-36	24
	Z2 - 12-4	44
025030233	R - 1-2-10	38
	P2 - 1-3-1-5	30
	P2 - 1-3-1-8	30
025040232	L - 1-8	18
	M - 1-5	20
	N - 1-12	22
	N - 1-21	22
	N - 20	22
	Q - 1-2-19	36
	S - 4	38
	P1 - 1-115	26
	P2 - 1-48	28

CODE	REF.NO.	Page
025040232	P2 - 1-91	28
	P2 - 1-182	28
	P2 - 1-211	28
	P2 - 1-246	30
	P3 - 1-254	32
	P3 - 1-259	32
	P3 - 5	34
025040233	Q - 1-2-9	36
025040332	Q - 1-2-15	36
025050232	N - 1-26	22
	N - 16	22
	Q - 1-1-6	36
	Q - 1-2-11	36
	Q - 10	36
	P2 - 1-12	28
	P3 - 1-236	32
	P3 - 1-268	32
025060232	F - 20-5	12
	H - 1-13	14
	M - 1-7	20
	M - 4	20
	P1 - 1-4	24
	Z2 - 8	44
025080232	M - 1-9	20
025080236	Z1 - 6-8	42
025080336	Q - 1-5	36
025100132	N - 1-18	22
025350132	P3 - 1-275	34
025680232	E - 44-18	10
	F - 20-12	12
025710232	A - 10-7	2
025800332	C - 11-8	4
	C - 11-13	4
028030242	N - 1-9-3	22
	P1 - 1-35	24
	P2 - 1-84	28
028030243	N - 25	22
	R - 1-2-3	38
	R - 1-2-9	38
	S - 1-2	38
	T - 4-2	40
	T - 6	40
	P2 - 1-3-1-4	30
	P2 - 1-3-1-7	30
	P2 - 1-3-3-2	30
	P2 - 1-3-4-2	30
028040242	L - 1-5	18
	L - 1-7	18
	M - 1-4	20
	M - 1-16	20
	N - 1-11	22
	N - 19	22
	N - 23	22
	Q - 1-2-8	36
	Q - 1-2-18	36
	S - 3	38
	P1 - 1-116	26
	P2 - 1-10	28
	P2 - 1-49	28
	P2 - 1-90	28
	P2 - 1-183	28
	P2 - 1-210	28
	P2 - 1-245	30

CODE	REF.NO.	Page
028040242	P3 - 1-193	32
	P3 - 1-221	32
	P3 - 1-255	32
	P3 - 1-260	32
028040243	R - 1-2-7	38
	P3 - 21	34
028050242	N - 1-25	22
	N - 15	22
	Q - 1-1-5	36
	Q - 1-2-17	36
	Q - 9	36
	P2 - 1-13	28
	P3 - 1-3-6	34
	P3 - 1-237	32
028060242	M - 3	20
	N - 1-8	22
	Q - 1-1-10	36
	Q - 6	36
	P1 - 8	26
028080240	Z1 - 6-7	42
028080242	N - 1-27	22
	Q - 1-4	36
	Q - 16	36
032422003	Z1 - 101	42
032452502	R - 3	38
	T - 10	40
	Z2 - 31	44
034422006	Z2 - 5-2	44
047250642	E - 44-5-8	8
048025342	Q - 1-2-1-4	36
	P3 - 1-263	32
048030342	P3 - 1-232	32
	P3 - 1-269	32
048040342	H - 1-14	14
	M - 1-8	20
048050342	F - 8-7	12
	H - 1-11	14
048060342	M - 1-10	20
	N - 1-5	22
	N - 5	22
	N - 8	22
	P1 - 1-104	26
048080142	C - 26	4
048080342	N - 1-17	22
048090342	L - 1-1-1	18
048150142	P2 -	28
	1-207-2-1	
052400806	R - 1-2-1	38
	R - 1-3	38
	R - 1-4	38
	R - 1-5	38
	P2 - 1-202	28
	P3 - 4	34
061500804	P3 - 1-251	32
062260406	P3 - 1-267	32
062300605	N - 1-9-2	22
	N - 1-9-5	22
	T - 7	40
062301212	P1 - 1-29	24
062301606	N - 24	22
062400616	P3 - 1-191	32
062400806	Q - 1-1-13	36
062401006	Q - 1-2-16	36
062401416	Z2 - 6-3	44

CODE	REF.NO.	Page
062670512	P3 - 1-274	34
062671212	D - 11-3	6
062680512	A - 15	2
	E - 16	8
	E - 44-5-7	8
062680812	E - 44-5-15	10
062710612	D - 13	6
	J - 1-6	16
	J - 1-14	16
062711012	E - 40	8
	J - 2	16
	J - 4	16
	J - 16	16
	T - 13	40
062711212	A - 10-6	2
062761212	L - 16	18
062761612	F - 71	12
062780812	F - 20-4	12
071055650	C - 7	4
071079450	C - 5	4
100022005	P1 - 1-112	26
100136001	J - 1-10-6	16
	J - 1-12-4	16
	J - 1-15-5	16
100507000	F - 18	12
100887001	Z2 - 25	44
101125000	N - 29	22
101572101	Z2 - 16	44
102571003	C - 14	4
105191001	F - 20-13	12
105329001	A - 19	2
105730001	Z1 - 25-1	42
105812003	D - 1-5	6
106436001	A - 27	2
106629002	H - 10	14
107153001	G - 12	14
107231002	H - 3	14
107779001	Z2 - 23	44
107780001	Z2 - 26	44
108520009	A - 21	2
110104000	A - 24	2
110124001	G - 13-1	14
110161004	C - 16-5	4
	F - 73	12
	H - 1-5	14
110251001	M - 1-12	20
110367001	P1 - 1-103	26
110744002	F - 23-2	12
112751003	C - 4-4	4
112758009	J - 17	16
114483002	Z2 - 28	44
114980001	E - 41	8
114984000	A - 10-3	2
	A - 13	2
114985001	A - 14	2
114986101	A - 16	2
114988001	A - 20	2
114992000	C - 4-2	4
114997001	C - 6	4
115000000	C - 8-9	4
115004001	C - 8-6	4
115008000	C - 10	4
	G - 8	14

CODE	REF.NO.	Page
115011201	C - 11-3	4
115012002	C - 11-4	4
115018001	C - 11-12	4
115022001	C - 13	4
115025001	A - 10-5-2	2
115042001	D - 1-1-5	6
115048101	D - 1-2-1	6
115053014	Z2 - 4	44
115053016	D - 9	6
	Z2 - 4	44
115053018	Z2 - 4	44
115066000	G - 16-1	14
115067001	G - 16-3	14
115068101	G - 16-5	14
115073001	K - 5	18
115076001	K - 6	18
115077001	K - 7	18
115078101	E - 1	8
115080000	E - 3	8
115094001	E - 18	8
115095001	E - 21	8
	E - 22	8
115096000	E - 19	8
115097001	E - 20	8
	E - 30-2	8
115098001	E - 31	8
115099001	E - 32	8
115101001	E - 17	8
115105001	E - 15	8
115108301	E - 39	8
115113001	B - 1-3	2
115114001	B - 1-4	2
115115001	B - 1-5	2
115116001	B - 1-6	2
115118001	B - 3	2
115126001	F - 3	12
115146001	E - 65	10
115156001	E - 44-5-6	8
115158001	E - 44-5-9	8
115166001	E - 44-13	10
	U - 2-1-7	42
115183101	J - 1-13	16
115186001	J - 1-12-1	16
115187101	J - 1-10-3	16
	J - 1-12-2	16
	J - 1-15-2	16
115188002	J - 1-12-3	16
115215100	C - 1	4
115268002	A - 10-5-3	2
115275001	A - 17	2
115947001	Q - 5	36
	P1 - 7	26
	Z2 - 10	44
116016001	Z2 - 6-4	44
116185209	Z2 - 6	44
116694001	Z1 - 6-6	42
117437109	Z2 - 6-1	44
117934009	A - 22	2
117936009	A - 23	2
118064001	Z2 - 21	44
118837001	Z2 - 15	44
119270001	Z1 - 25	42
119271001	Z1 - 25	42

CODE	REF.NO.	Page
119707003	Z1 - 6-3	42
119708001	Z1 - 6-4	42
122991001	Z2 - 1	44
	Z2 - 33	44
133188001	Z1 - 6-2	42
133824001	Z1 - 26	42
140208001	P3 - 1-146	32
140553102	D - 10	6
141334001	N - 28	22
	P1 - 1-32	24
	P1 - 1-121	26
	P2 - 1-87	28
142205001	Z2 - 24	44
142268001	N - 1-9-1	22
142307001	A - 10-5-1	2
142443001	Z2 - 14	44
142658001	D - 1-1-1-1	6
142721001	Z2 - 20	44
143966001	Z2 - 12-2	44
144504001	J - 12-2	16
144505000	J - 12-3	16
144543001	Q - 4	36
	Z2 - 7	44
145480101	F - 22	12
146354001	E - 44-7	10
	F - 20-8	12
	J - 1-7	16
	J - 5	16
146360002	E - 24	8
	E - 43	8
	F - 20-7	12
147151000	G - 6	14
	G - 10	14
147691000	A - 28	2
148425002	D - 1-1-2-1	6
148546001	L - 1-9	18
	M - 1-6	20
	P2 - 1-94	28
148587001	P1 - 1-111	26
148589001	P1 - 1-117	26
148592001	P1 - 1-119	26
148924101	J - 1-10-5	16
149073001	P2 - 1-212	28
149547000	Q - 1-1-12	36
149996001	C - 8-12	4
	C - 11-15	4
150335001	Z2 - 22	44
150553001	H - 1-12	14
150554002	C - 11-5	4
	N - 11	22
150556001	E - 44-12	10
	E - 66	10
	J - 1-16	16
151601002	G - 16-4	14
151602001	G - 16-6	14
151605002	A - 10-4	2
151932001	H - 2	14
152877001	P3 - 1-234	32
153122000	N - 1-23	22
153242000	Z2 - 35	44
153596001	C - 27	4
154125001	Z2 - 19	44
155510001	J - 12-4	16
155559001	H - 1-15	14
156874001	F - 72	12
158449001	A - 25	2
158998001	N - 10	22
159272001	M - 5	20
159805001	J - 1-10-4	16
	J - 1-15-3	16
183943001	G - 11	14
200190001	Z2 - 32	44
215769001	R - 1-2-5	38
	Z2 - 34	44
552907000	T - 12	40

brother®

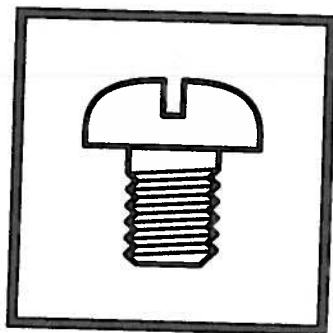

パーツブック
PARTS BOOK
TEILEKATALOG
LIVRE DES PIECES
LIBRO DE REFERENCIA DE PIEZAS

ブラザー工業株式会社

〒467-8561 名古屋市瑞穂区苗代町15番1号 TEL(052)824-2392

BROTHER INDUSTRIES, LTD.

15-1, Naeshiro-cho, Mizuho-ku, Nagoya 467-8561, Japan. Phone: 81-52-824-2177

Printed in Japan / Gedruckt in Japan / Imprimé au Japon / Impreso en Japón

151-910
195910-401
2002.04. B (1)

