

brother

BAS-304A

プログラム式電子ミシン

PROGRAMMABLE ELECTRONIC PATTERN SEWER WITH CYLINDER BED

ELECTRONISCH-FREI-PROGRAMMIERBARER STEPPSTICH-ZYLINDERARM-VOLLAUTOMAT

AUTOMATE DE COUTURE PROGRAMMABLE-BRAS CYLINDRIQUE

AUTOMATA ELECTRONICA PROGRAMABLE DE BASE CILINDRICA

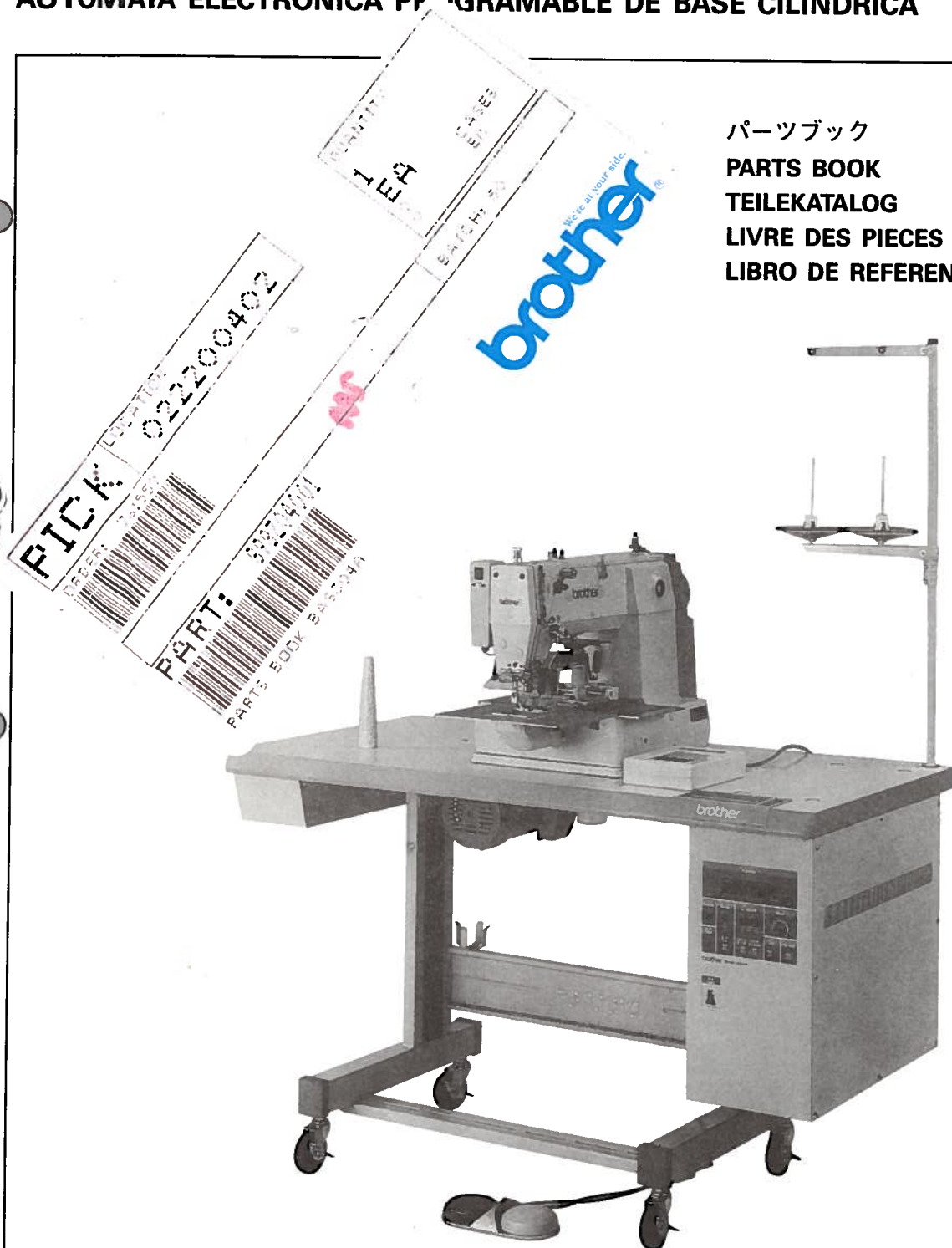

パーツブック

PARTS BOOK

TEILEKATALOG

LIVRE DES PIECES

LIBRO DE REFERENCIA DE PIEZAS

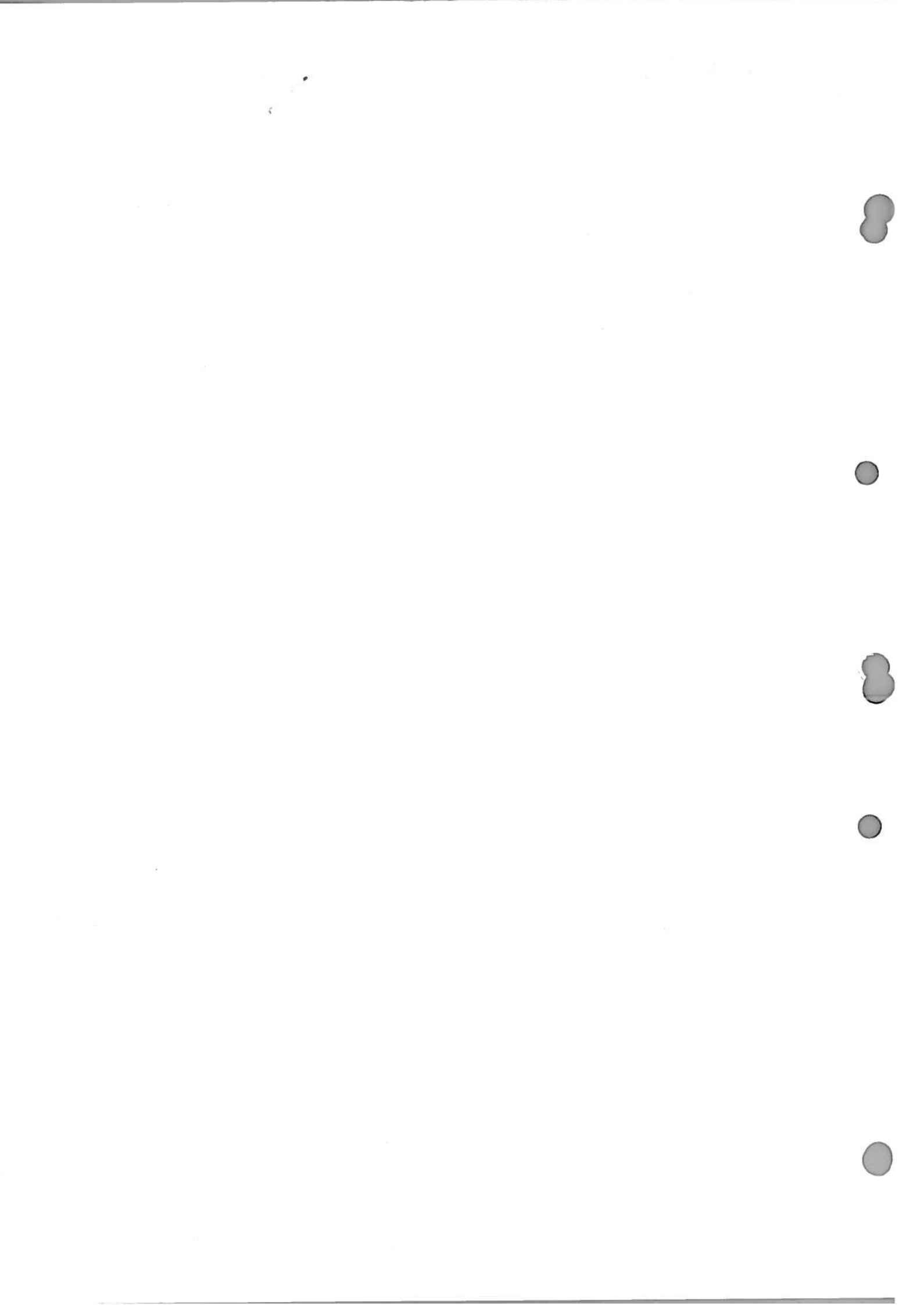

パーツブックご利用に際して

1. 組単位で補給する部品は、 破線で示しております。
2. この本は1992年11月のデータに基づいて作成されたものです。
3. 部品は予告なしに設計変更される場合があります。

目 次

A. 主体関係(1).....	2	M. 糸切り関係.....	28
B. 主体関係(2).....	4	N. 糸締メ関係.....	30
C. 上軸針棒関係.....	6	P. 電装品関係.....	32
D1. 送り関係.....	8	Q. 針位置検出器関係.....	34
D2. 送り関係.....	10	R. プリント基板関係.....	34
D3. 送り関係.....	12	S. コントロールボックス関係.....	36
E. ワイパー関係.....	12	T. 空圧関係.....	40
F. 押エ上ゲ関係.....	14	U. 動力台関係.....	42
G. 駆動側・送り関係.....	18	V. 踏板関係.....	44
H. 下軸関係.....	20	W. 付属装置関係.....	44
J. 給油・潤滑関係.....	22	Z. 付属品関係.....	46
K. 糸通シ関係.....	24	オプションパーツ.....	47~50
L. 糸巻関係.....	26	索引.....	51~57

Notes for using this parts book

1. Parts supplied as complete assemblies are circled by a dotted line .
2. This book was prepared based on information available in November 1992.
3. Parts are subject to changes in design without prior notice.

CONTENTS

A. Machine body (1)	2
B. Machine body (2)	4
C. Upper shaft and needle bar mechanism	6
D1. Feed mechanism	8
D2. Feed mechanism	10
D3. Feed mechanism	12
E. Thread wiper mechanism	12
F. Work clamp lifter mechanism	14
G. Feed guide mechanism	18
H. Lower shaft mechanism	20
J. Lubrication	22
K. Threading mechanism	24
L. Bobbin winder mechanism	26
M. Thread trimmer mechanism	28
N. Thread nipper mechanism	30
P. Power supply equipment mechanism	32
Q. Synchronizer	34
R. Printed circuit board mechanism	34
S. Control box mechanism	36
T. Air pressure mechanism	40
U. Power Table	42
V. Foot switch pedal mechanism	44
W. Programmer device	44
Z. Accessories	46
Optional parts	47 ~ 50
INDEX	51 ~ 57

Hinweise zur Verwendung dieser Teileiste

1. Die Teile, die als kompletter Satz geliefert werden, sind mit einer  gestrichelten Linie umrandet.
2. Dieses Buch basiert auf den Informationen vom November 1992.
3. Modelländerungen sind vorbehalten.

INHALTSVERZEICHNIS

A. Maschinengehäuse (1)	2
B. Maschinengehäuse (2)	4
C. Obere Welle und Nadelstangenvorrichtung	6
D1. Transportvorrichtung	8
D2. Transportvorrichtung	10
D3. Transportvorrichtung	12
E. Fadenwischvorrichtung	12
F. Stoffhalterhebevorrichtung	14
G. Transportführung	18
H. Untere Welle	20
J. Schmierung	22
K. Fadenführungsvorrichtung	24
L. Spuler	26
M. Fadenabschneidevorrichtung	28
N. Fadenspannvorrichtung	30
P. Schaltkasten	32
Q. Synchronisator	34
R. Leiterplatten	34
S. Stromversorgung	36
T. Luftdruck	40
U. Motorgestell	42
V. Fußbetätigung	44
W. Programmvorrichtung	44
Z. Zubehör	46
Sonderzubehör	47 ~ 50
VERZEICHNIS	51 ~ 57

Notes sur l'utilisation de ce manuel de pièces détachées



1. Les pièces fournies en tant qu'assemblages complets sont encadrées avec un trait pointillé .
2. Ce manuel a été fait d'après les renseignements valables au mois de Novembre 1992.
3. Les pièces peuvent être sujettes à des modifications sans préavis.

TABLE DES MATIERES

A. Corps de la machine (1)	2
B. Corps de la machine (2)	4
C. Mécanisme de arbre supérieur et barre à aiguille	6
D1. Mécanisme de l'entraînement	8
D2. Mécanisme de l'entraînement	10
D3. Mécanisme de l'entraînement	12
E. Mécanisme de tire-fil	12
F. Mécanisme de leueur du pinceur	14
G. Mécanisme du guide de l'entraînement	18
H. Mécanisme de l'arbre inférieur	20
J. Lubrification	22
K. Mécanisme de l'enfilage	24
L. Mécanisme du bobineur	26
M. Mécanisme de coupe-fil	28
N. Mécanisme de pince-fil	30
P. Mécanisme de l'équipement en alimentation électrique	32
Q. Synchronisateur	34
R. Circuits imprimés	34
S. Mécanisme du boîtier de contrôle	36
T. Mécanisme de la pression d'air	40
U. Mécanisme du plateau de la machine	42
V. Mécanisme de la pédale	44
W. Dispositif du programmeur	44
Z. Accessoires	46
Pieces en option	47 ~ 50
INDEX	51 ~ 57

Notas para usar este Libro de Piezas

1. Las piezas suministradas como conjuntos completos se enmarcan con una línea punteada .
2. Este libro ha sido compilado basándose en los datos de que se disponía en noviembre 1992.
3. Las piezas quedan sujetas a cambios de diseño sin aviso previo.

INDICE

A. Cuerpo de la máquina (1)	2
B. Cuerpo de la máquina (2)	4
C. Mecanismo de eje superior y barra de aguja	6
D1. Mecanismo de la alimentación	8
D2. Mecanismo de la alimentación	10
D3. Mecanismo de la alimentación	12
E. Mecanismo de limpiador de hilos	12
F. Mecanismo de levantador de ménsula de trabajo	14
G. Mecanismo de la guía de alimentación	18
H. Mecanismo de la eje inferior	20
J. Lubricación	22
K. Mecanismo de la enhebrado	24
L. Mecanismo del devanador de la canilla	26
M. Mecanismo de recortadora de orillos	28
N. Mecanismo de mordaza para hilos	30
P. Mecanismo de la equipo de alimentación de corriente	32
Q. Sincronizador	34
R. Tableros de circuitos impresos	34
S. Mecanismo del caja de controles	36
T. Mecanismo de la presión de aire	40
U. Mecanismo del mesa de trabajo la máquina	42
V. Mecanismo de la pedal	44
W. Programadora	44
Z. Accesorios	46
Piezas opción	47 ~ 50
INDICE	51 ~ 57

A. 主体関係(1) / Machine body (1)/Maschinengehäuse (1)/
 Corps de la machine (1)/Cuerpo de la máquina (1)

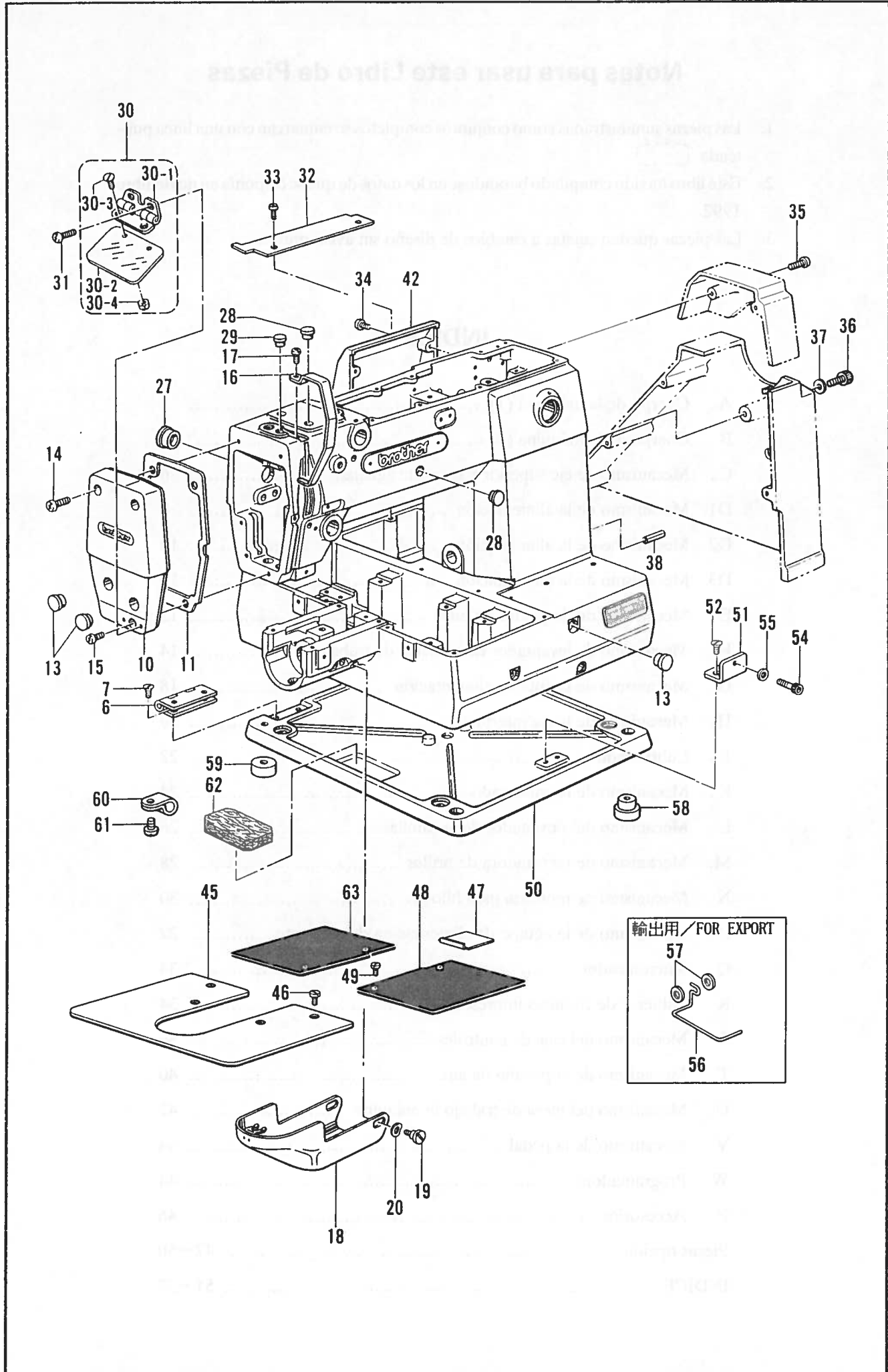

A. 主体関係1) /Machine body (1)/Maschinengehäuse (1)/
Corps de la machine (1)/Cuerpo de la máquina (1)

REF NO.	CODE	Q'TY	ヒンメイ	NAME OF PARTS	RMKS
6	S10026001	2	ヘ"ツト"ヒンシ"	BED HINGE	
7	107231002	8	サラネシ"4.76	SCREW 4.76	
10	S10027002	1	メンイタ	FACE PLATE	
11	S10028000	1	メンイタハ"ツッキン	PACKING	
13	117934009	3	メクラセン	OIL CAP	
14	062711412	2	ナヘ"コ4.76-32X14	SCREW 476X14	
15	062711012	1	ナヘ"コ476-32X10	SCREW 4.76X10	
16	S10029109	1	デンピン"カハ"	THREAD TAKE-UP COVER	
17	062670812	1	ナヘ"コ3.57-40X8	SCREW 3.57X8	
18	S10030002	1	オオカマカハ"ークミ	LARGE SHUTTLE HOOK COVER ASSY	
19	153718001	2	タ"ンネシ"5.95	STUD SCREW 5.95	
20	109239002	2	ナミハ"ネサ"カ"ネ	WAVE SPRING WASHER	
27	140392009	1	オイルフタ	OIL CAP	
28	117936009	8	メクラセン	OIL CAP	
29	104450109	1	メクラセン	OIL CAP	
30	153100000	1	アイガ"ート"クミ	EYE GUARD ASSY	
30-1	153102001	1	アイガ"ート"チヨウハ"ンクミ	EYE GUARD HINGE ASSY	
30-2	153098000	1	アイガ"ート"	EYE GUARD	
30-3	102538007	2	サラネシ"3.57	SCREW 3.57	
30-4	106129001	2	ナツト3.57	NUT 3.57	
31	062670512	2	ナヘ"コ357-40X5	SCREW 3.57X5	
32	S18695001	1	ソクメンカハ"シタカハ"	FRAME SIDE COVER	
33	062680812	2	ナヘ"コ437-40X8	SCREW 4.37X8	
34	062711212	4	ナヘ"コ476-32X12	SCREW 4.76X12	
35	062711212	2	ナヘ"コ476-32X12	SCREW 4.76X12	
36	018503022	1	アナホ"ルト5X30	BOLT 5X30	
37	025050232	1	ヒラサ"ガ"ネチユウ-5	PLAIN WASHER 5	
38	047501242	2	スプリング"ピンAW5	SPRING PIN AW5	
42	S10260002	1	ソクメンカハ"	FRAME SIDE COVER	
45	S10090001	1	ハリイタホシ"ヨイタ	NEEDLE SUB PLATE	
46	153208002	4	シメネシ"4.37	SCREW 4.37	
47	S10141009	1	Yオクリタ"イカハ"-B	Y-FEED BASE COVER (B)	
48	S10142100	1	Xオクリタ"イカハ"	X-AXIS FEED BASE COVER	
49	153208002	4	シメネシ"4.37	SCREW 4.37	
50	S18672001	1	ヘ"ツト"タイ	BED BASE	
51	S10025001	1	ヘ"ツト"カケカ"ネ	BED LATCH	
52	107231002	2	サラネシ"4.76	SCREW 4.76	
54	148425002	1	アナホ"ルト4.37X14	BOLT 4.37X14	
55	025680132	1	ヒラサ"ガ"ネシヨウ4.37	PLAIN WASHER 4.37	
56	S02445001	1	-----	FINGER GUARD	
57	025350236	2	-----	PLAIN WASHER 3.5	
58	S10258000	2	クツシヨンA	CUSHION (A)	
59	S10259000	2	クツシヨンB	CUSHION (B)	
60	625010000	1	ナイロンクランフ°NK-2N	CORD HOLDER NK-2N	
61	062670612	1	ナヘ"コ357-40X6	SCREW 3.57X6	
62	S10169000	1	カマキユウユフエルト	FELT	
63	S19658000	1	Xオクリタ"イカハ"-L	X-FEED BRACKET COVER (L)	

B. 主体関係(2)/Machine body (2)/Maschinengehäuse (2)/
Corps de la machine (2)/Cuerpo de la máquina (2)

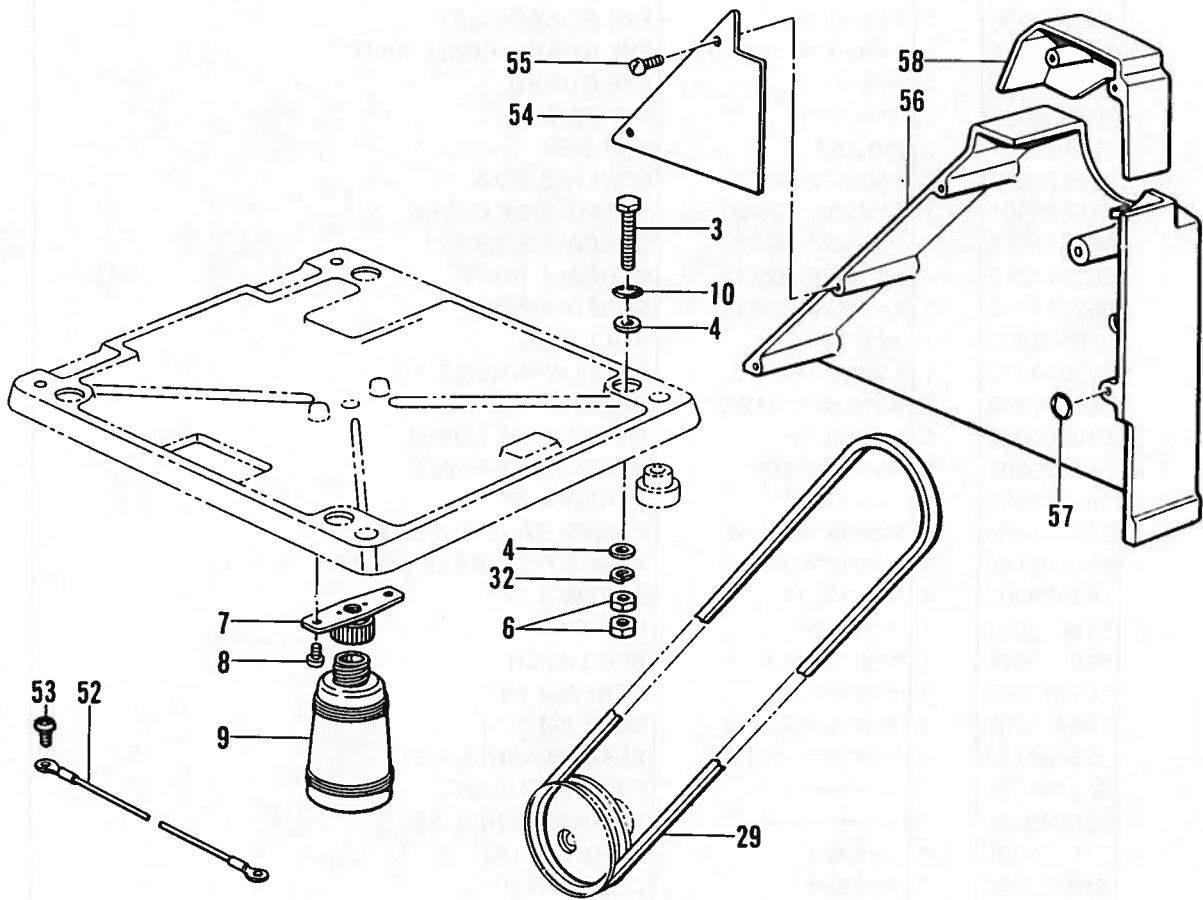

B. 主体関係(2)/Machine body (2)/Maschinengehäuse (2)/
Corps de la machine (2)/Cuerpo de la máquina (2)

REF.NO.	CODE	Q'TY	ヒンメイ	NAME OF PARTS	RMKS
3	017067002	4	ボルト6X70	BOLT 6X70	
4	025060332	8	ヒラサ"カ"ネタ"イ6	PLAIN WASHER 6	
6	021060102	8	ナット1シユ6	NUT 6	
7	154465001	1	ハイユキヤツプ"ササエクミ	DUST OILER SUPPORT ASSY	
8	062710612	2	ナヘ"コ476-32X6	SCREW 4.76X6	
9	114486002	1	ホ"リオイルタイ	OILER	
10	081006070	4	Oリング"P6	O RING P6	
29	S18707149	1	VベルトMシロ	V BELT (M49)	
32	028060242	4	ハ"ネサ"カ"ネ2-6	SPRING WASHER 2-6	
52	S10406001	1	アースセン	EARTH WIRE	
53	062710612	1	ナヘ"コ476-32X6	SCREW 4.76X6	
54	S18694009	1	ベルトカハ"-マイタ	BELT COVER FRONT COVER	
55	062680612	2	ナヘ"コ4.37-40X6	SCREW 4.37X6	
56	S10262009	1	ベルトカハ"-D	BELT COVER (D)	
57	S10473000	2	クツシヨング"ム	CUSHIONING WASHER	
58	S10261009	1	ベルトカハ"-U	BELT COVER (U)	

C. 上軸針棒關係 / Upper shaft and needle bar mechanism / Obere Welle und Nadelstangenvorrichtung /
 Mécanisme de arbre supérieur et barre à aiguille / Mecanismo de eje superior y barra de agujaja

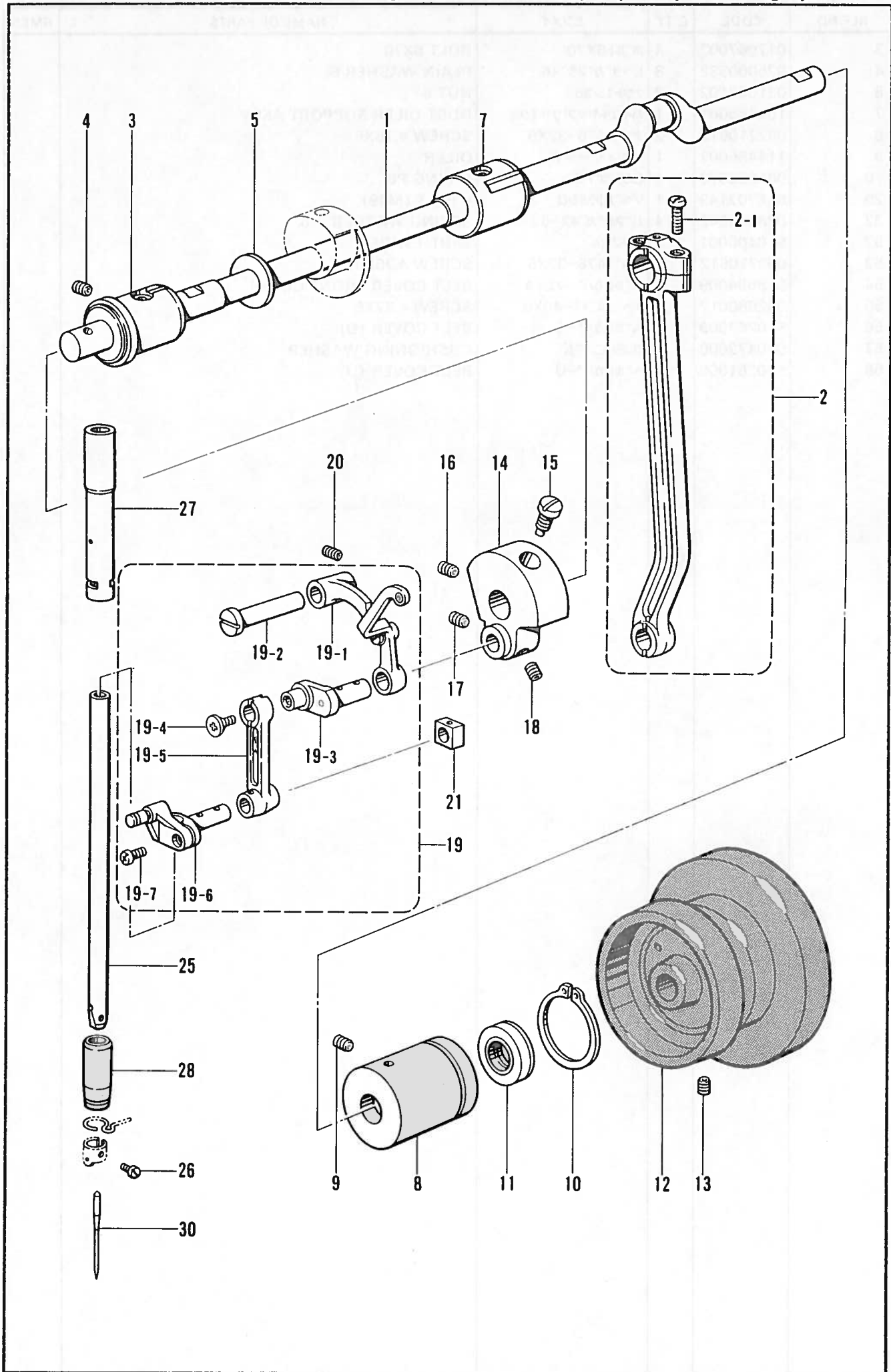

C. 上軸針棒関係/Upper shaft and needle bar mechanism/Obere Welle und Nadelstangenvorrichtung/
 Mécanisme de arbre supérieur et barre à aiguille/Mecanismo de eje superior y barra de aguja

REF NO.	CODE	Q'TY	ヒンメイ	NAME OF PARTS	RMKS
1	S10035001	1	ウフジク	UPPER SHAFT	
2	S10036001	1	クランクロッドクミ	CRANK ROD ASSY	
2-1	144712001	2	シメネジ"4.76	SCREW 4.76	
3	S10038001	1	ウフジクメタルF	UPPER SHAFT BUSH (F)	
4	014760622	1	アナトメネジ"5.95	SET SCREW 5.95	
5	101482001	1	レンカンシキリイタ	CONNECTING ROD PARTITION PLATE	
7	140726000	1	ウフジクメタルM	UPPER SHAFT BUSH (M)	
8	S10039001	1	ウフジクメタルR	UPPER SHAFT BUSH (R)	
9	014760622	1	アナトメネジ"5.95	SET SCREW 5.95	
10	S10383001	1	トメウシクヨウC36	STOP RING C36	
11	101487000	1	オイルシール	OIL SEAL	
12	S02538009	1	プーリ	PULLEY	
13	014760622	2	アナトメネジ"5.95	SET SCREW 5.95	
14	S10040001	1	テンヒンクランク	THREAD TAKE-UP CRANK	
15	100250001	1	シメネジ"7.14	SCREW 7.14	
16	014770622	1	アナトメネジ"6.35クボ"ミ	SET SCREW 6.35	
17	101706001	1	トメネジ"6.35	SET SCREW 6.35	
18	014770622	1	アナトメネジ"6.35クボ"ミ	SET SCREW 6.35	
19	S10041001	1	ハリホ"ウレンカンクミ	THREAD TAKE-UP LEVER ASSY	
19-1	153330001	1	テンヒンクミ	THREAD TAKE-UP ASSY	
19-2	152236001	1	テンヒンササエジク	THREAD TAKE-UP SUPPORT STUD	
19-3	152237001	1	ハリホ"ウクランク	NEEDLE BAR CRANK	
19-4	132051001	1	+サラネジ"3.57L	SCREW 3.57L	
19-5	S10042001	1	ハリホ"ウレンカン	THREAD TAKE-UP LEVER	
19-6	S10043001	1	ハリホ"ウタ"キ	NEEDLE BAR CLAMP	
19-7	062680812	1	ナヘ"ゴ437-40X8	SCREW 4.37X8	
20	014760622	1	アナトメネジ"5.95	SET SCREW 5.95	
21	142211001	1	カクコマ	SLIDE BLOCK	
25	S02269001	1	ハリホ"ウ	NEEDLE BAR	
26	144458001	1	アタマツキトメネジ"3.57	SET SCREW 3.57	
27	S10044001	1	ハリホ"ウメタルU	NEEDLE BAR BUSH (U)	
28	152243001	1	ハリホ"ウメタルD	NEEDLE BAR BUSH (D)	
<チュウアツモノヨウ /FOR MEDIUM THICK MATERIALS>					
30	107415016	1	ミシンハリDPX5(#16)	NEEDLE DPX5 (#16)	
<アツモノヨウ /FOR THICK MATERIALS>					
30	145646021	1	ミシンハリDPX17(#21)	NEEDLE DPX17 (#21)	

D1. 送り関係 / Feed mechanism / Transportvorrichtung /
 Mécanisme de l'entraînement / Mecanismo de la alimentación

電磁用 / SOLENOID TYPE

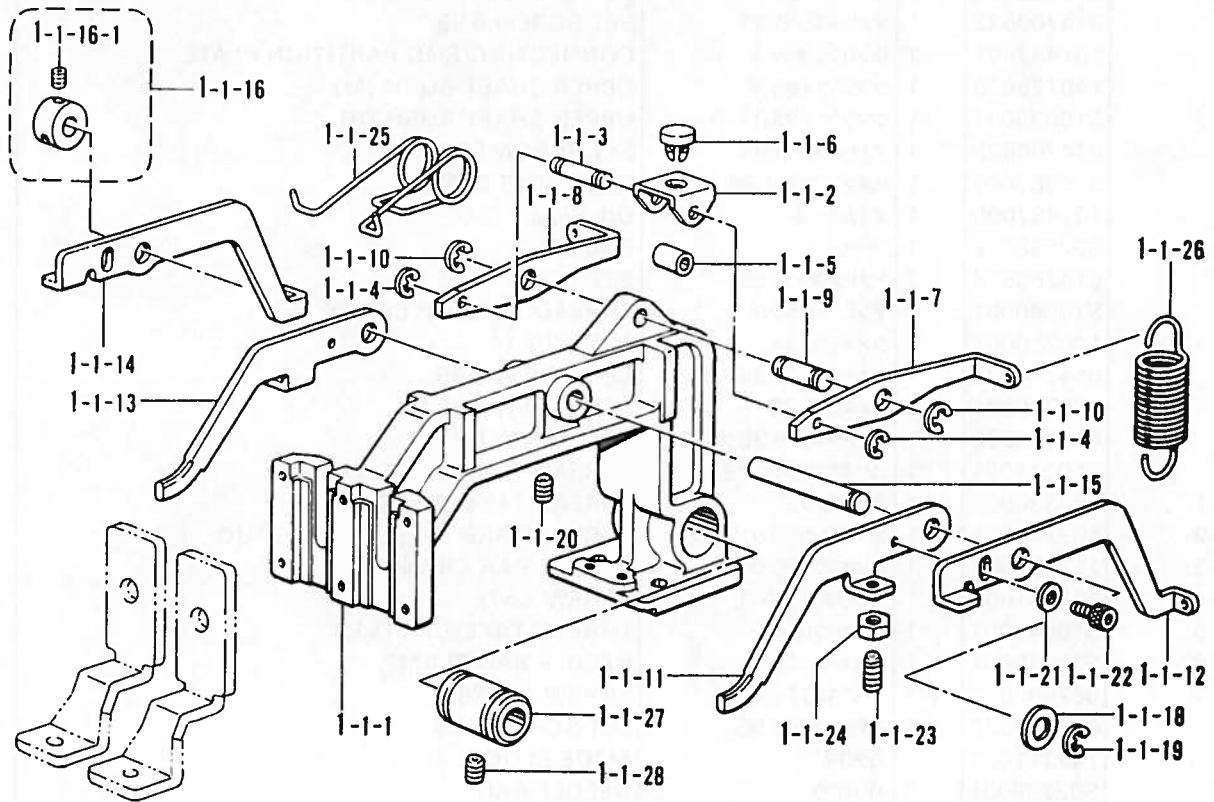

エア用 / AIR TYPE

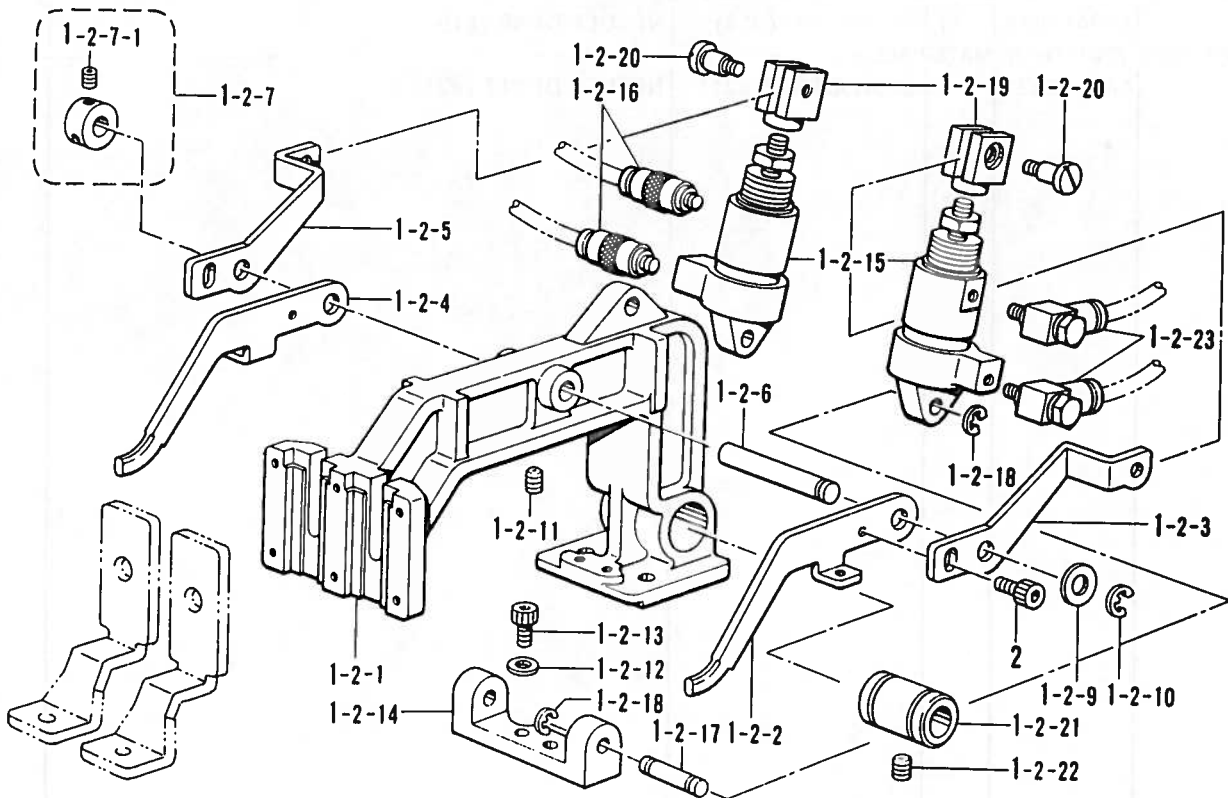

D1. 送り関係 / Feed mechanism / Transportvorrichtung /
 Mécanisme de l'entraînement / Mecanismo de la alimentación

REF.NO.	CODE	Q'TY	ヒンメイ	NAME OF PARTS	RMKS
<デンジヨウ / SOLENOID TYPE>					
1-1	S10045009	1	オサエウテ"クミ	PRESSER ARM ASSY	
1-1-1	S10046009	1	オサエウテ"	PRESSER FOOT ARM	
1-1-2	S10047001	1	スライダ"ーササエ	SLIDER SUPPOT	
1-1-3	S10048001	1	スライダ"ーササエシ"ク	SLIDER SUPPOT SHAFT	
1-1-4	048030342	2	トメフE3	STOP RING E3	
1-1-5	S10049001	1	ササエシ"クカンザ"	SPACER	
1-1-6	S10050000	1	スライダ"ー	SLIDER	
1-1-7	S10051001	1	オサエアケ"レハ"ーR	PRESSER BAR LIFTER LEVER (R)	
1-1-8	S10052001	1	オサエアケ"レハ"ーL	PRESSER BAR LIFTER LEVER (L)	
1-1-9	S10053001	1	オサエアケ"レハ"ーシ"ク	PRESSER BAR LIFTER SHAFT	
1-1-10	048040342	2	トメフE4	STOP RING E4	
1-1-11	S10054001	1	オサエウテ"レハ"ーFR	PRESSER FOOT ARM LEVER (FR)	
1-1-12	S10055001	1	オサエウテ"レハ"ーRR	PRESSER FOOT ARM LEVER (RR)	
1-1-13	S10056001	1	オサエウテ"レハ"ーFL	PRESSER FOOT ARM LEVER (FL)	
1-1-14	S10057001	1	オサエウテ"レハ"ーRL	PRESSER FOOT ARM LEVER (RL)	
1-1-15	S10058001	1	オサエウテ"レハ"ーシ"ク	PRESSER FOOT ARM LEVER SHAFT	
1-1-16	S21776001	1	セツトカラークミ	SET COLLAR ASSY	
1-1-16-1	014680622	2	アナトメネシ"4.37クホ"ミ	SET SCREW 4.37	
1-1-18	143591001	1	スラストリンク"	THRUST RING	
1-1-19	048050342	1	トメフE5	STOP RING E5	
1-1-20	014760622	1	アナトメネシ"5.95	SET SCREW 5.95	
1-1-21	025040232	2	ヒラサ"カ"ネチユウ4	PLAIN WASHER 4	
1-1-22	018400622	2	アナホ"ルト4X6	BOLT 4X6	
1-1-23	014401232	2	アナトメネシ"4X12ヒラ	SET SCREW 4X12	
1-1-24	021400102	2	ナツト1シユ4	NUT 4	
1-1-25	S10059001	1	オサエウテ"レハ"ーハ"ネ	SPRING	
1-1-26	S10060101	2	オサエハ"ネ	SPRING	
1-1-27	S03899000	1	ホ"ールフ"ツシユV	BALL BUSH (V)	
1-1-28	011679312	1	トメネシ"3.57ヒラ	SET SCREW 3.57	
<エア"ヨウ / AIR TYPE>					
1-2	S10375109	1	オサエウテ"クミAIR	PRESSER FOOT ARM ASSY (AIR)	
1-2-1	S10046009	1	オサエウテ"	PRESSER FOOT ARM	
1-2-2	S10054001	1	オサエウテ"レハ"ーFR	PRESSER FOOT ARM LEVER (FR)	
1-2-3	S10377101	1	オサエウテ"レハ"ーRR	PRESSER FOOT ARM LEVER (RR)	
1-2-4	S10056001	1	オサエウテ"レハ"ーFL	PRESSER FOOT ARM LEVER (FL)	
1-2-5	S10378101	1	オサエウテ"レハ"ーRL	PRESSER FOOT ARM LEVER (RL)	
1-2-6	S10058001	1	オサエウテ"レハ"ーシ"ク	PRESSER FOOT ARM LEVER SHAFT	
1-2-7	S21776001	1	セツトカラークミ	SET COLLAR ASSY	
1-2-7-1	014680622	2	アナトメネシ"4.37クホ"ミ	SET SCREW 4.37	
1-2-9	143591001	1	スラストリンク"	THRUST RING	
1-2-10	048050342	1	トメフE5	STOP RING E5	
1-2-11	014760622	1	アナトメネシ"5.95	SET SCREW 5.95	
1-2-12	025040232	2	ヒラサ"カ"ネチユウ4	PLAIN WASHER 4	
1-2-13	018400622	2	アナホ"ルト4X6	BOLT 4X6	
1-2-14	S10379001	1	シリンダ"ササエ	CYLINDER SUPPORT	
1-2-15	S10380101	2	エアシリンダ"	AIR CYLINDER	
1-2-16	S18415001	2	ハーフユニオンQ4M5	HALF UNION	
1-2-17	S03800001	2	クレビス"スピ"ン	CLEVIS PIN	
1-2-18	048040342	4	トメフE4	STOP RING E4	
1-2-19	S03801001	2	シリンダ"ツキ"テ	CYLINDER JOINT	
1-2-20	110168001	2	コロシ"ク	ROLLER SHAFT	
1-2-21	S03899000	1	ホ"ールフ"ツシユV	BALL BUSH (V)	
1-2-22	011679312	1	トメネシ"3.57ヒラ	SET SCREW 3.57	
1-2-23	S03820000	2	エルボ"M5	ELBOW M5	
2	018501222	2	アナホ"ルト5X12	BOLT 5X12	

D2. 送り関係/Feed mechanism/Transportvorrichtung/
 Mécanisme de l'entraînement/Mecanismo de la alimentación

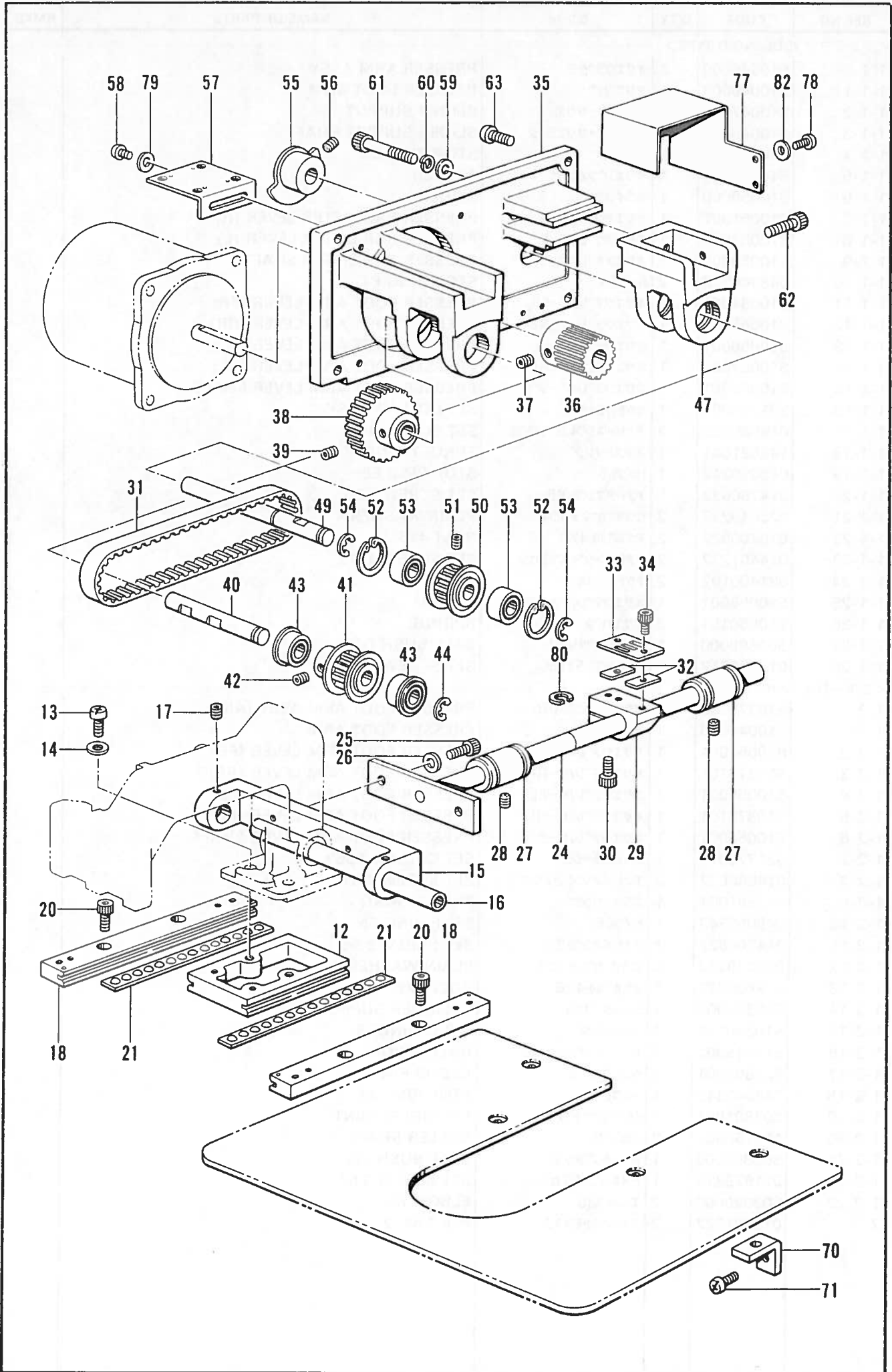

D2. 送り関係 / Feed mechanism / Transportvorrichtung /
Mécanisme de l'entraînement / Mecanismo de la alimentación

REF.NO.	CODE	Q'TY	ヒンメイ	NAME OF PARTS	RMKS
12	S10066001	1	Yオクリタ"イ	Y-FEED BRACKET	
13	062761412	2	ナヘ"コ595-28X14	SCREW 595X14	
14	025060132	2	ヒラサ"カ"ネシヨウ6	PLAIN WASHER 6	
15	S31663009	1	Xオクリシ"クササエ	X-FEED SHAFT SUPPORT	
16	S31664001	1	Xオクリシ"ク	X-FEED SHAFT	
17	014680622	2	アナホ"ルト4.37クホ"ミ	SET SCREW 4.37	
18	S18679001	2	Yオクリアンナイクミ	Y-FEED GUIDE ASSY	
20	018680822	4	アナホ"ルト4.37X8	BOLT 4.37X8	
21	S18680100	2	Yリテーナクミ	Y-RETAINER ASSEMBLY	
24	S31567001	1	Yクト"ウシ"ク	Y-DRIVING SHAFT	
25	018501022	2	アナホ"ルト5X10	BOLT 5X10	
26	025050232	2	ヒラサ"カ"ネチユウ-5	PLAIN WASHER 5	
27	S03899000	2	ホ"ールフ"ツシユV	BALL BUSH (V)	
28	014680622	2	アナホ"ルト4.37クホ"ミ	SET SCREW 4.37	
29	S31568000	1	Yクト"ウシ"クホルタ"	Y-DRIVING SHAFT HOLDER	
30	018501622	1	アナホ"ルト5X16	BOLT 5X16	
31	S10077100	1	Yタイミンク"ヘ"ルト	Y-TIMING BELT	
32	S10078001	2	T"ヘ"ルトスヘ"ーサ	TIMING BELT SPACER	
33	S10079001	1	ヘ"ルトホルタ"	BELT HOLDER	
34	018680822	2	アナホ"ルト4.37X8	BOLT 4.37X8	
35	S10080001	1	Yクト"ウPモータヘ"ース	DRIVING (P) MOTOR BASE	
36	S10081001	1	クト"ウキ"ヤ	DRIVING GEAR	
37	014760622	2	アナホ"ルト5.95	SET SCREW 5.95	
38	S10082001	1	アイト"ルキ"ヤ	IDLE GEAR	
39	014760622	2	アナホ"ルト5.95	SET SCREW 5.95	
40	S10083001	1	Yプ"ーリシ"クA	Y-PULLEY SHAFT (A)	
41	S27844001	1	タイミンク"プ"ーリA	TIMING PULLEY (A)	
42	014770622	2	アナホ"ルト6.35クホ"ミ	SET SCREW 6.35	
43	070688850	2	タマシ"クウケ688ZZNR	BALL BEARING 688ZZNR	
44	048060342	1	トメフE6	STOP RING E6	
47	S10085000	1	Yクト"ウPモータフ"ラケット	MOTOR BRACKET	
49	S10086001	1	Yプ"ーリシ"クB	Y-PULLEY SHAFT (B)	
50	S10087101	1	タイミンク"プ"ーリB	TIMING PULLEY (B)	
51	014400522	2	アナホ"ルト4X5	SET SCREW 4X5	
52	048160242	2	トメフアナヨウC16	STOP PING C16	
53	530138001	2	マイクロヘ"アリング"8	MICRO BEARING 8	
54	048060342	2	トメフE6	STOP RING E6	
55	S10088001	1	Yケ"ンテント"ク	Y-AXIS HOME POSITION DOG	
56	014760622	1	アナホ"ルト5.95	SET SCREW 5.95	
57	S10089001	1	Yキハ"ントリツケイタ	Y-CIRCUIT BOARD SET PLATE	
58	062680812	2	ナヘ"コ437-40X8	SCREW 4.37X8	
59	025050232	2	ヒラサ"カ"ネチユウ-5	PLAIN WASHER 5	
60	028050242	2	ハ"ネサ"カ"ネ2-5	SPRING WASHER 2-5	
61	018505022	2	アナホ"ルト5X50	BOLT 5X50	
62	018503022	1	アナホ"ルト5X30	BOLT 5X30	
63	062711212	4	ナヘ"コ476-32X12	SCREW 4.76X12	
70	S10091001	4	ハリイタホシ"ヨイタササエ	NEEDLE SUB PLATE SUPPORT	
71	062680812	4	ナヘ"コ437-40X8	SCREW 4.37X8	
77	S10471001	1	センサ"ーカハ"ー	SENSOR COVER	
78	062670612	2	ナヘ"コ357-40X6	SCREW 3.57X6	
79	100645003	2	サ"カ"ネ	WASHER	
80	148782001	1	スヘ"ーサ	SPACER	
82	025680232	2	ヒラサ"カ"ネチユウ4.37	PLAIN WASHER 4.37	

D3. 送り関係 / Feed mechanism / Transportvorrichtung /
 Mécanisme de l'entraînement / Mecanismo de la alimentación

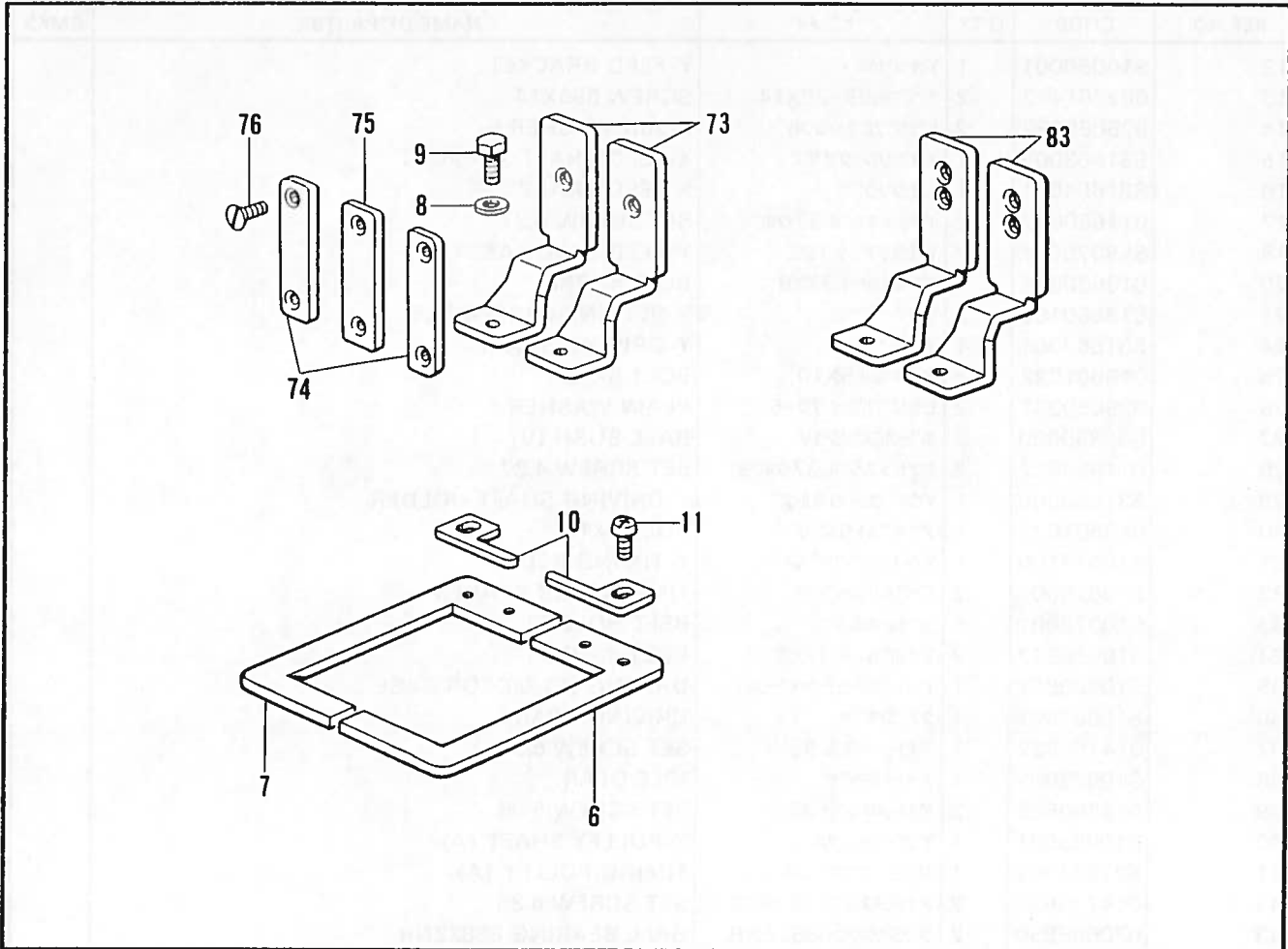

E. ワイパー関係 / Thread wiper mechanism / Fadenwischvorrichtung /
 Mécanisme de tire-fil / Mecanismo de limpiador de hilos

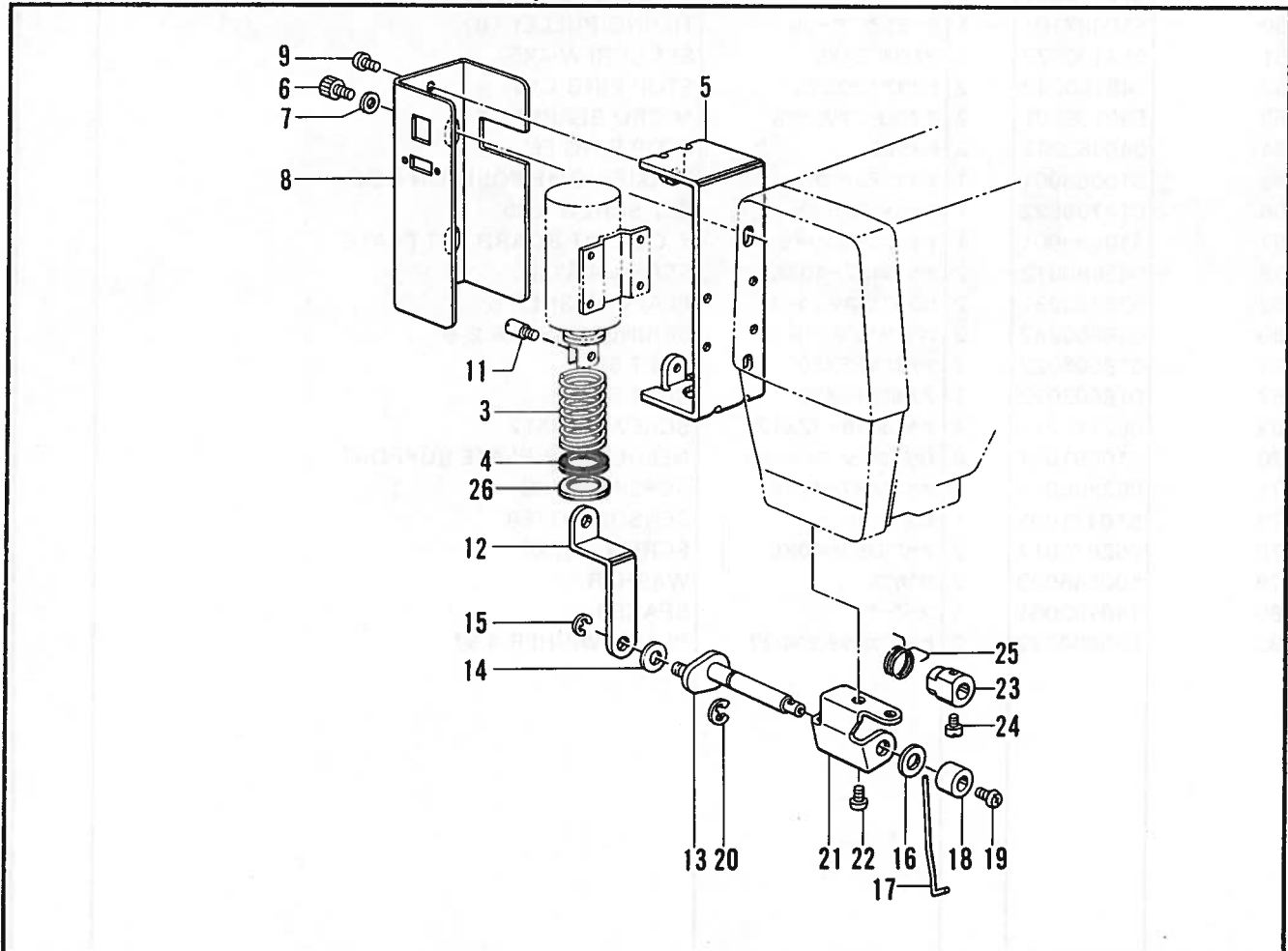

D3. 送り関係 / Feed mechanism / Transportvorrichtung /
Mécanisme de l'entraînement / Mecanismo de la alimentación

REF.NO.	CODE	Q'TY	ヒンメイ	NAME OF PARTS	RMKS
6	S18677001	1	オサER	PRESSER FOOT (R)	
7	S18676001	1	オサEL	PRESSER FOOT (L)	
8	025680232	2	ヒロサ"カ"ネチユウ4.37	PLAIN WASHER 4.37	
9	153403002	2	ボ"ルト4.37X7	BOLT 4.37X7	
10	S10065001	2	イチキ"メ"イタ	POSITIONING PLATE	
11	062680512	2	ナヘ"コ437-40X5	SCREW 4.37X5	
73	S10063001	2	オサEアシSE	WORK CLAMP (SE)	
74	153369001	2	オサEアシオサEイタA	WORK CLAMP GUIDE PLATE (A)	
75	153370001	1	オサEアシオサEイタB	WORK CLAMP GUIDE PLATE (B)	
76	107038003	6	サラネジ"3.57	SCREW 3.57	
<ホキユウヨウ /FOR SUPPLY>					
83	S12587001	1	オサEアシSE-S	WORK CLAMP (SE-S)	

E. ワイパー関係 / Thread wiper mechanism / Fadenwischvorrichtung /
Mécanisme de tire-fil / Mecanismo de limpiador de hilos

REF.NO.	CODE	Q'TY	ヒンメイ	NAME OF PARTS	RMKS
3	S02667001	1	イトハライハ"ネ	SPRING	
4	S02668000	1	プ"ランシ"ヤ"ゴ"ム	PLUNGER STOPPER	
5	S10214009	1	ソレノイト"トリツケイタ	SOLENOID SETTING PLATE	
6	018681022	2	アナボ"ルト4.37X10	BOLT 4.37X10	
7	100645003	2	サ"カ"ネ	WASHER	
8	S10215009	1	ソレノイト"カハ"ー	SOLENOID COVER	
9	062680512	2	ナヘ"コ437-40X5	SCREW 4.37X5	
11	S02680001	1	プ"ランシ"ヤ"ピ"ン	PLUNGER PIN	
12	S10216009	1	イトハライレ"ン"カ"ン	THREAD WIPER CONNECTING ROD	
13	S10217001	1	イトハライクラン"ク"ミ	THREAD WIPER CRANK ASSY	
14	110735001	1	サ"カ"ネ	WASHER	
15	048030342	1	トメ"ワ"E3	STOP RING E3	
16	S03677001	1	サ"カ"ネ	WASHER	
17	S10470001	1	ワイ"パ"ー	THREAD WIPER	
18	146288001	1	イトハライシ"ク"カラ"ー	THREAD WIPER STUD COLLAR	
19	060680512	1	ハ"イ"ント"437-40X5	SCREW 4.37X5	
20	048040342	1	トメ"ワ"E4	STOP RING E4	
21	S02672002	1	イトハライシ"ク"ウ"ケ"イ"タ	THREAD WIPER SUPPORT	
22	062680512	2	ナヘ"コ437-40X5	SCREW 4.37X5	
23	S02677001	1	セツ"ト"カラ"ー	SET COLLAR	
24	144458001	1	アタマツキ"ト"メ"ネ"ジ"3.57	SET SCREW 3.57	
25	S02678001	1	ワイ"パ"ー"ハ"ネ	SPRING	
26	S15589000	1	ス"パ"ー"サ	SPACER	

F. 押工上ゲ関係 / Work clamp lifter mechanism / Stoffhalterhebevorrichtung /
 Mécanisme de levreur du pinceur / Mecanismo de levantador de ménsula de trabajo

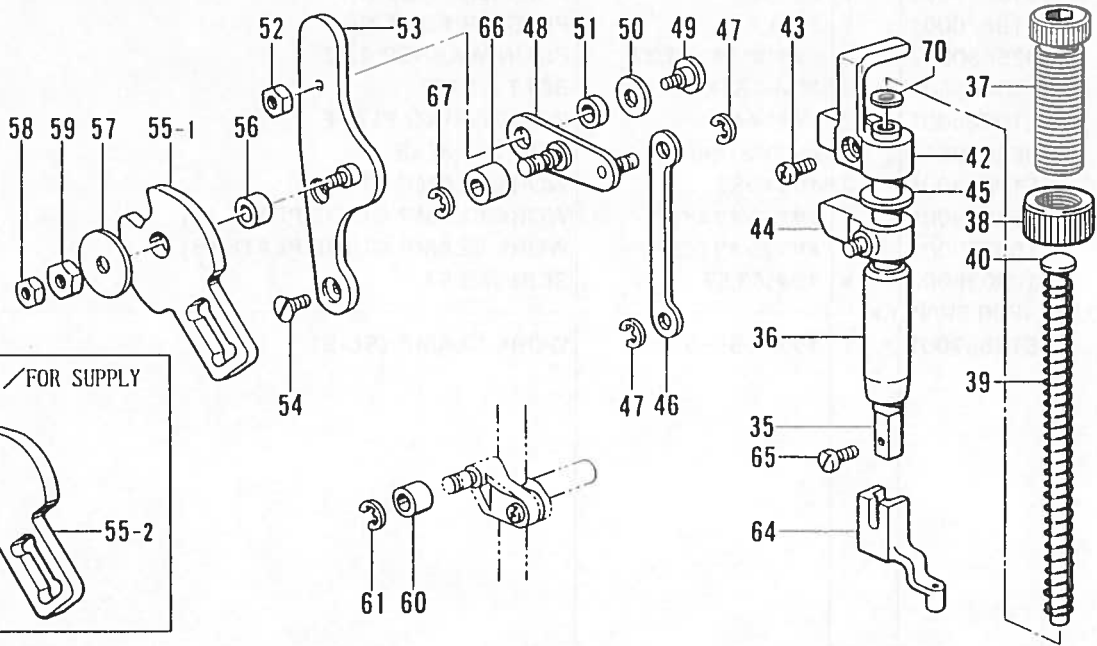

補給用 / FOR SUPPLY

電磁用 / SOLENOID TYPE

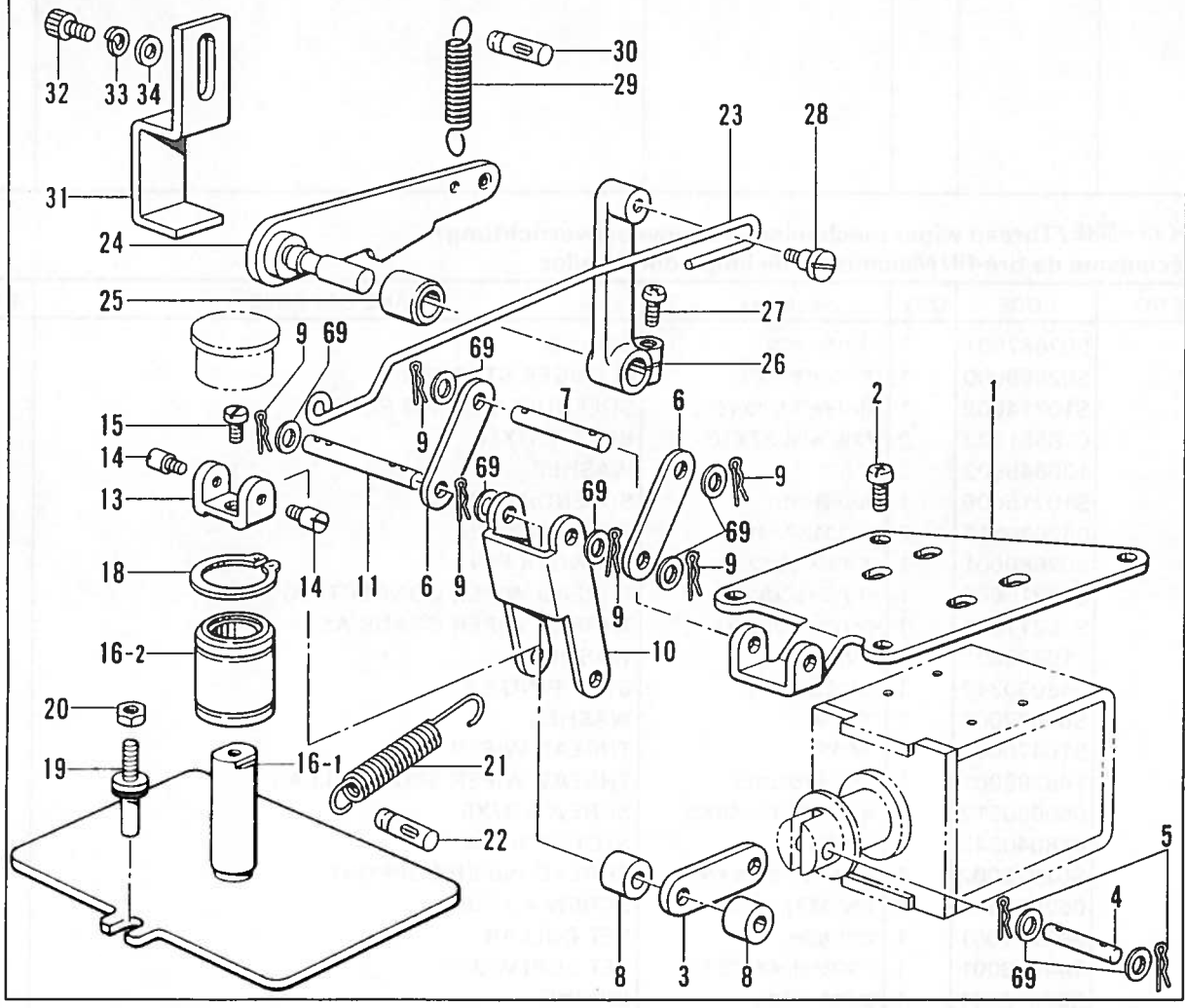

エア-用 / FOR AIR

F. 押工上ケ関係 / Work clamp lifter mechanism / Stoffhalterhebevorrichtung /
 Mécanisme de leveur du pinceur / Mecanismo de levantador de ménsula de trabajo

REF.NO.	CODE	Q'TY	ヒンメイ	NAME OF PARTS	RMKS
			<テンジ"ヨウ /	SOLENOID TYPE>	
1	S10092001	1	ソレノイド"トリツケイタ	SOLENOID SET PLATE	
2	062710812	4	ナヘ"コ476-32X8	SCREW 476X8	
3	S10093001	1	リンクC	LINK (C)	
4	S19661001	1	プ"ランシ"ヤヒン	PLUNGER PIN	
5	S19662001	2	スナツフ"ヒン5	SNAP PIN	
6	S10095001	2	リンクA	LINK (A)	
7	S19663001	1	リンクシ"クA	LINK SHAFT (A)	
8	S10097001	2	リンクシ"クカラー	COLLAR	
9	S19662001	2	スナツフ"ヒン5	SNAP PIN	
10	S10098001	1	リンクB	LINK (B)	
11	S19664001	1	リンクシ"クB	LINK SHAFT (B)	
13	S30026001	1	リンクヒンジ"	LINK HINGE	
14	S10101001	2	ヒンジ"シ"ク	HINGE SHAFT	
15	153208002	1	シメネシ"4.37	SCREW 4.37	
16-1	S10102001	1	オサエイタ	PRESSER PLATE	
16-2	S10103001	1	ホ"ールフ"ツシユ	BALL BUSH	
18	048200142	1	トメワシ"クヨウC20	STOP RING C20	
19	S10474001	1	アンナイシ"ククミ	GUIDE SHAFT ASSY	
20	110161004	1	ナツト4.76	NUT 4.76	
21	S10105001	1	リンクモト"シハ"ネ	SPRING	
23	S10106001	1	ロツト"	ROD	
24	S10107001	1	オサエアク"レハ"ー	PRESSER BAR LIFTER LEVER	
25	140263000	1	オサエウテ"シ"クメタルL	PRESSER ARM SHAFT BUSH (L)	
26	S10108001	1	オサエアク"レハ"ーウテ"	PRESSER BAR LIFTER LEVER ARM	
27	062681212	1	ナヘ"コ437-40X12	SCREW 4.37X12	
28	115559002	1	タ"ンネシ"4.76	STUD SCREW 4.76	
29	S10109001	1	オサエアク"レハ"ーハ"ネ	SPRING	
30	159379001	1	ミソ"ツキヒンBX6X18	DOWEL PIN BX6X18	
31	S10110001	1	オサエアク"ストツハ"	STOPPER	
32	018061222	2	アナホ"ルト6X12	BOLT 6X12	
33	028060242	2	ハ"ネサ"カ"ネ2-6	SPRING WASHER 2-6	
34	025060232	2	ヒラサ"カ"ネチユ6	PLAIN WASHER 6	
69	153484001	8	サ"カ"ネ4.76	WASHER 4.76	
<エア-ヨウ /AIR TYPE>					
62	S10125009	1	メクラセン	OIL CAP	
63	S00313009	1	メクラセン	OIL CAP	
22	159379001	1	ミソ"ツキヒンBX6X18	DOWEL PIN BX6X18	
35	111466101	1	オサエホ"ウ	PRESSER BAR	
36	145472001	1	オサエホ"ウメタル	PRESSER BAR BUSH	
37	S31012001	1	オサエチヨウセツネシ"	ADJUST SCREW	
38	S31013001	1	チヨウセツネシ"ツマミナツト	NUT	
39	S10111001	1	オサエハ"ネ	SPRING	
40	S10112001	1	オサエハ"ネアンナイ	SPRING GUIDE	
42	S10113001	1	オサエホ"ウタ"キ	PRESSER BAR GUIDE BRACKET	
43	062681212	1	ナヘ"コ437-40X12	SCREW 4.37X12	
44	S10371001	1	オサエホ"ウリフター	PRESSER BAR LIFTER	
45	S10372100	1	オサエホ"ウタ"キクツシヨソ	CUDHION	
46	S10114001	1	カンケツリンク	INTERMITTENT LINK	
47	048040342	2	トメワE4	STOP RING E4	
48	S10115001	1	ヨウト"ウリンククミ	ROCK LINK ASSY	
49	107321003	1	タ"ンネシ"4.76	STUD SCREW 4.76	
50	159486001	1	サ"カ"ネ	WASHER	
51	S10119001	1	ヨウト"ウリンクカラー	COLLAR	
52	021710202	1	ナツト2シユ4.76	NUT 4.76	
53	S10361001	1	カムト"ダ"イクミ	CAM BASE ASSY	
54	100032004	2	サラネシ"4.37	SCREW 4.37	
55-1	S10121001	1	カンケツカム4-7	INTERMITTENT CAM 4-7	
56	S10123001	1	オサエカムカラー	COLLAR	
57	S00902001	1	メスサト"ウレハ"サ"カ"ネD	WASHER (D)	
58	021680202	1	ナツト2シユ4.37	NUT 4.37	

F. 押工上ケ関係 / Work clamp lifter mechanism / Stoffhalterhebevorrichtung /
 Mécanisme de levreur du pinceur / Mecanismo de levantador de ménsula de trabajo

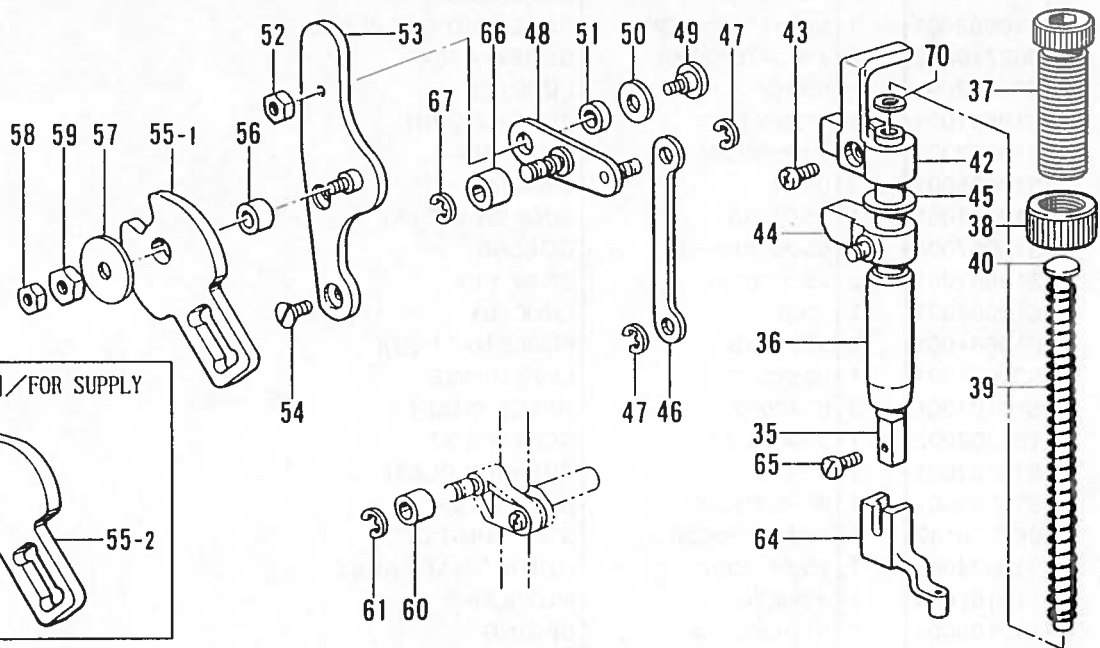

電磁用 / SOLENOID TYPE

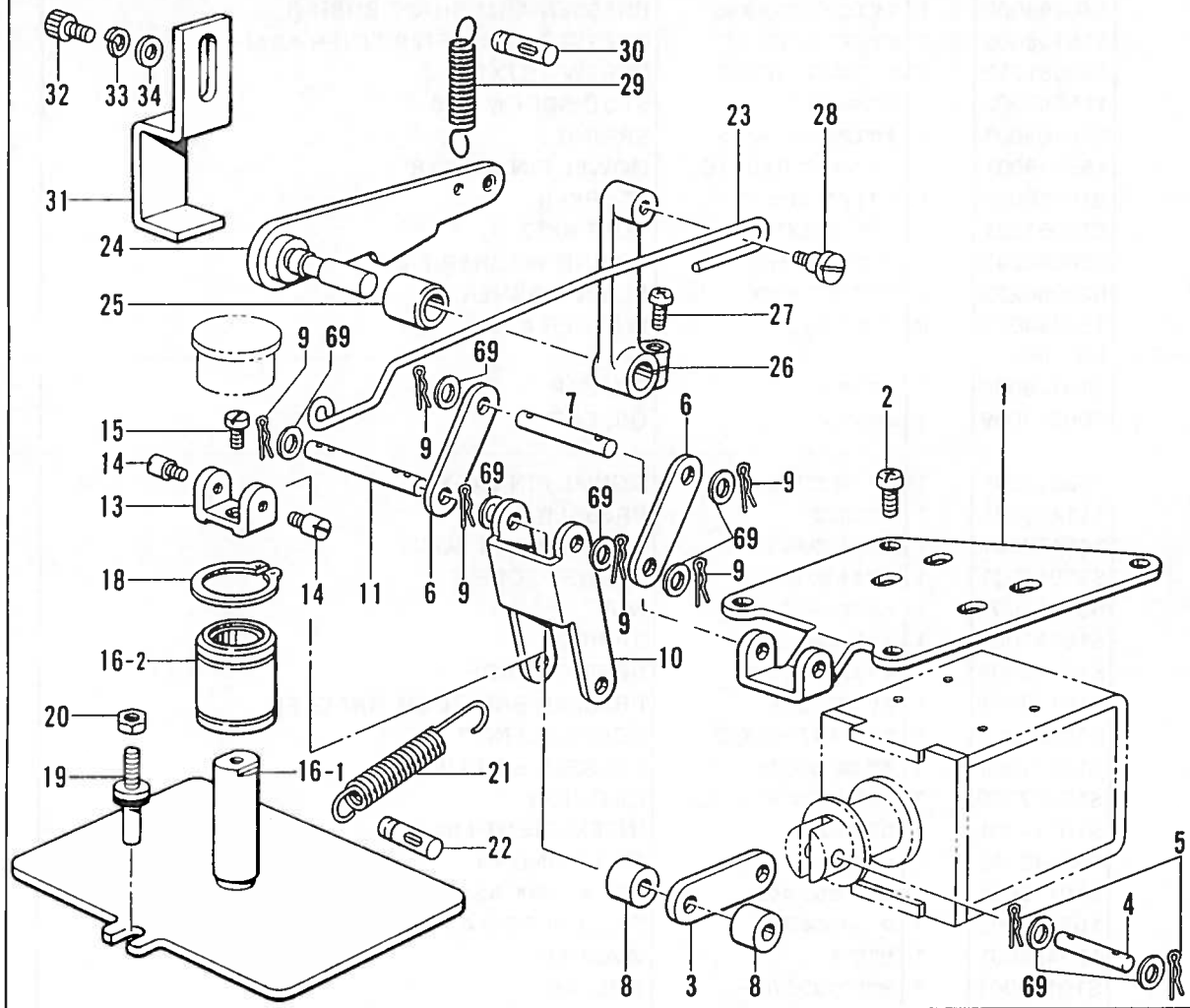

エア-用 / FOR AIR



F. 押工上げ関係 / Work clamp lifter mechanism / Stoffhalterhebervorrichtung /
 Mécanisme de levreur du pinceur / Mecanismo de levantador de ménsula de trabajo

REF NO.	CODE	Q'TY	ヒンメイ	NAME OF PARTS	RMKS
59	102571003	1	ナット4.37	NUT 4.37	
60	107744001	1	コロ	ROLLER	
61	048030342	1	トメワE3	STOP RING E3	
64	152283101	1	オサエアシA	WORK CLAMP (A)	
65	S13399001	1	シメネジ"3.57X12	SCREW 3.57X12	
66	S15695001	1	コロ	ROLLAR	
67	048030342	1	トメワE3	STOP RING E3	
70	S03677001	1	サ"カ"ネ	WASHER	
<ホキユウヨウ /FOR SUPPLY>					
55-2	S10122001	1	カンケツカム10	INTERMITTENT CAM 10	

G. 駆動側・送り関係 / Feed guide mechanism / Transportführung /
 Mécanisme du guide de l'entraînement / Mecanismo de la guía de alimentación

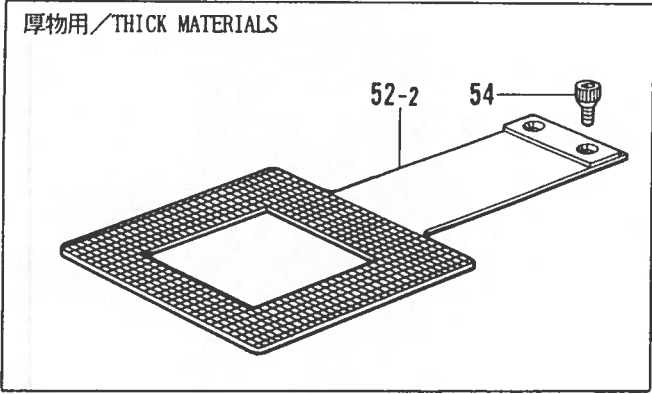
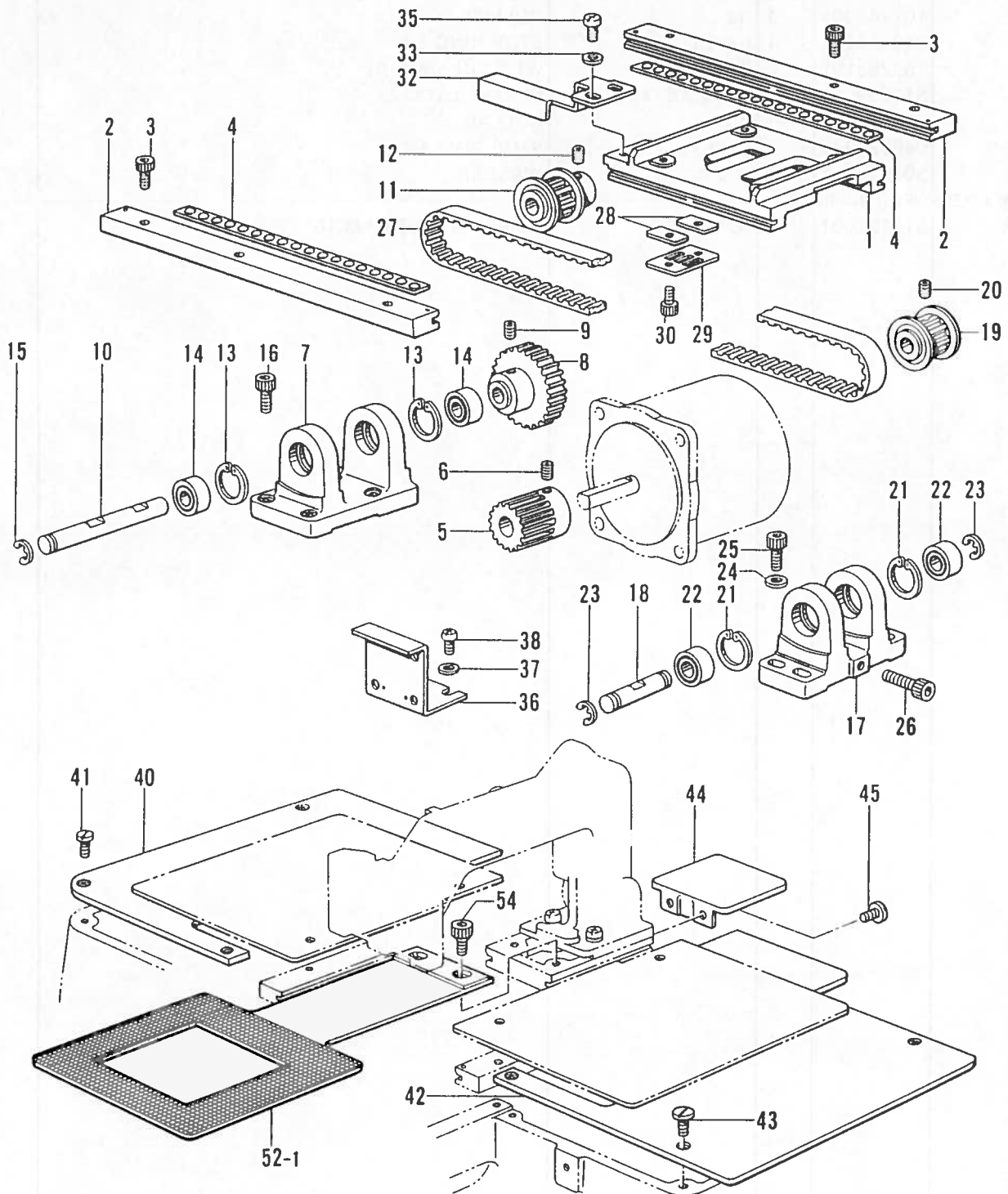

G. 駆動側・送り関係 / Feed guide mechanism / Transportführung /
 Mécanisme du guide de l'entraînement / Mecanismo de la guía de alimentación

REF NO.	CODE	Q'TY	ヒンメイ	NAME OF PARTS	RMKS
1	S10126001	1	オクリタ"IX	X-FEED BRACKET	
2	S18692001	2	Xオクリアンナイクミ	X-FEED GUIDE ASSY	
3	148425002	6	アナホ"ルト4.37X14	BOLT 4.37X14	
4	S18690100	2	Xリテーナクミ	X-RETAINER ASSEMBLY	
5	S10081001	1	クト"ウキ"ヤ	DRIVING GEAR	
6	014760622	2	アナトメネジ"5.95	SET SCREW 5.95	
7	S10131000	1	Xプーリタ"IA	X-PULLEY BASE (A)	
8	S10082001	1	アイト"ルキ"ヤ	IDLE GEAR	
9	014760622	2	アナトメネジ"5.95	SET SCREW 5.95	
10	S10132001	1	Xプーリシ"クA	X-PULLEY SHAFT (A)	
11	S27844001	1	タイミング"プーリア	TIMING PULLEY (A)	
12	014770622	2	アナトメネジ"6.35クホ"ミ	SET SCREW 6.35	
13	048160242	2	トメワアナヨウC16	STOP PING C16	
14	530138001	2	マイクロ"アリング"8	MICRO BEARING 8	
15	048060342	1	トメワE6	STOP RING E6	
16	018501622	4	アナホ"ルト5X16	BOLT 5X16	
17	S10133000	1	Xプーリタ"IB	X-PULLEY BASE (B)	
18	S10134001	1	Xプーリシ"クB	X-PULLEY SHAFT (B)	
19	S10087101	1	タイミング"プーリB	TIMING PULLEY (B)	
20	014400522	2	アナクホ"ミ4X5	SET SCREW 4X5	
21	048160242	2	トメワアナヨウC16	STOP PING C16	
22	530138001	2	マイクロ"アリング"8	MICRO BEARING 8	
23	048060342	2	トメワE6	STOP RING E6	
24	025050232	4	ヒラサ"ガ"ネチユウ-5	PLAIN WASHER 5	
25	018501622	4	アナホ"ルト5X16	BOLT 5X16	
26	018502522	1	アナホ"ルト5X25	BOLT 5X25	
27	S18867000	1	Xタイミング"ベルト	X-TIMING BELT	
28	S10078001	2	T"ベルトス"パ"サ	TIMING BELT SPACER	
29	S10079001	1	"ベルトホルタ"	BELT HOLDER	
30	018680822	2	アナホ"ルト4.37X8	BOLT 4.37X8	
32	S19651001	1	Xゲ"ンデント"ク"	X-AXIS HOME POSITION DOG	
33	100645003	2	サ"ガ"ネ	WASHER	
35	062680812	2	ナヘ"コ437-40X8	SCREW 4.37X8	
36	S10137001	1	Xキハ"ントリツケイタ	X-CIRCUIT BOARD SET PLATE	
37	100645003	2	サ"ガ"ネ	WASHER	
38	062680812	2	ナヘ"コ437-40X8	SCREW 4.37X8	
40	S18688001	1	XYオクリタ"イカハ"-L	XY-FEED BASE COVER (L)	
41	153208002	4	シメネジ"4.37	SCREW 4.37	
42	S18689001	1	XYオクリタ"イカハ"-R	XY-FEED BASE COVER (R)	
43	153208002	4	シメネジ"4.37	SCREW 4.37	
44	S10140009	1	Yオクリタ"イカハ"-A	Y FEED BASE COVER (A)	
45	153208002	2	シメネジ"4.37	SCREW 4.37	
54	S10352101	2	オクリイタシメネジ"	FEED PLATE SCREW	
<チュウアツモノヨウ /FOR MEDIUM THICK MATERIALS>					
52-1	S18685001	1	オクリイタA	FEED PLATE (A)	
<アツモノヨウ /FOR THICK MATERIALS>					
52-2	S18686001	1	オクリイタB	FEED PLATE (B)	

H. 下軸関係 / Lower shaft mechanism / Untere Welle /
 Mécanisme de l'arbre inférieur / Mecanismo de la eje inferior

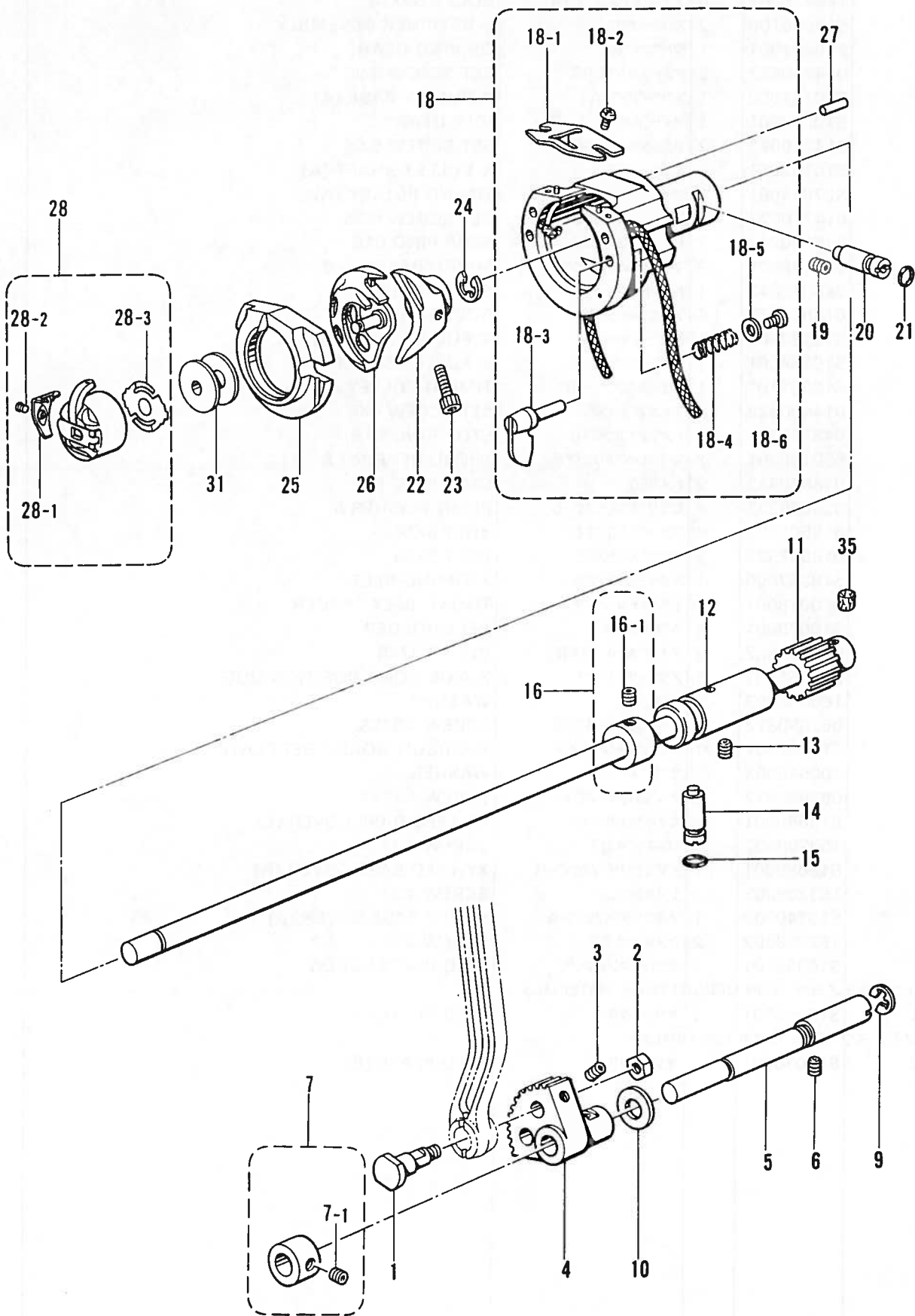

H. 下軸関係 / Lower shaft mechanism / Untere Welle /
 Mécanisme de l'arbre inférieur / Mecanismo de la eje inferior

REF.NO.	CODE	Q'TY	ヒンメイ	NAME OF PARTS	RMKS
1	141786001	1	クランクロッド"タ"ンネジ"	CRANK ROD STUD SCREW	
2	104689002	1	ナット7.14	NUT 7.14	
3	014680622	1	アナトメネジ"4.37クホ"ミ	SET SCREW 4.37	
4	S10145001	1	ヨウト"ウキ"ヤ	ROCK GEAR	
5	S11314001	1	ヨウト"ウキ"ヤシ"ク	ROCK GEAR SHAFT	
6	014760622	1	アナトメネジ"5.95	SET SCREW 5.95	
7	S21774001	1	セツトカラークミ	SET COLLAR ASSY	
7-1	123006001	2	トメネジ"6.35クホ"ミ	SET SCREW 6.35	
9	048080342	1	トメワE8	STOP RING E8	
10	110494001	1	サ"カ"ネ	WASHER	
11	S10147101	1	シタジ"ククミ	LOWER SHAFT ASSY	
12	S10149101	1	シタジ"クメタル	LOWER SHAFT BUSH	
13	014760622	1	アナトメネジ"5.95	SET SCREW 5.95	
14	152678001	1	カマチヨウセツシ"ク	SHUTTLE HOOK ADJUST STUD	
15	081003670	1	O"リング"PW3	O RING PW3	
16	S03704001	1	セツトカラークミ	SET COLLAR ASSY	
16-1	014770622	2	アナトメネジ"6.35クホ"ミ	SET SCREW 6.35	
18	S10373101	1	オオカマタイクミ	SHUTTLE RACE BASE ASSY	
18-1	S02429001	1	カマイトアンナイ	SHUTTLE RACE THREAD GUIDE	
18-2	062660412	2	ナヘ"コ318-40X4	SCREW 318X4	
18-3	152683001	2	オオカマトリツケツメ	LARGE SHUTTLE HOOK SET CLAW	
18-4	152684101	2	オオカマトリツケハ"ネ	SPRING	
18-5	402887001	2	サ"カ"ネ3.2	WASHER 3.2	
18-6	062660712	2	ナヘ"コ318-40X7	SCREW 318X7	
19	014760622	1	アナトメネジ"5.95	SET SCREW 5.95	
20	152678001	1	カマチヨウセツシ"ク	SHUTTLE HOOK ADJUST STUD	
21	081003670	1	O"リング"PW3	O RING PW3	
22	152681201	1	ト"ライハ"ー	DRIVER	
23	018501422	1	アナボ"ルト5X14	BOLT 5X14	
24	048080342	1	トメワE8	STOP RING E8	
27	141808001	1	オオカマアンナイピン	PIN	
28	S15902101	1	ボ"ビ"ンケースクミLA	BOBBIN CASE ASSY (LA)	
28-1	S16074001	1	ケースチヨウシハ"ネA	SPRING (A)	
28-2	S16492001	1	ボ"ビ"ンケースハ"ネネジ"	SCREW	
28-3	S15667001	1	クウテンボ"ウシハ"ネ	BOBBIN TENSION SPRING	
30	S15667001	1	クウテンボ"ウシハ"ネ	BOBBIN TENSION SPRING	
31	S15665001	1	ボ"ビ"ンLA	BOBBIN (LA)	
35	113006001	1	フェルト	FELT	
<チュウアツモノヨウ /FOR MEDIUM THICK MATERIALS>					
25	152682001	1	オオカマA	LARGE SHUTTLE HOOK (A)	
26	S15662001	1	ナカカマLA	INNER ROTARY HOOK (LA)	
<アツモノヨウ /FOR THICK MATERIALS>					
25	152686001	1	オオカマB	LARGE SHUTTLE HOOK (B)	
26	S15663001	1	ナカカマLB	INNER ROTARY HOOK (LB)	

J. 給油・潤滑関係/Lubrication/Schmierung/
Lubrification/Lubricación

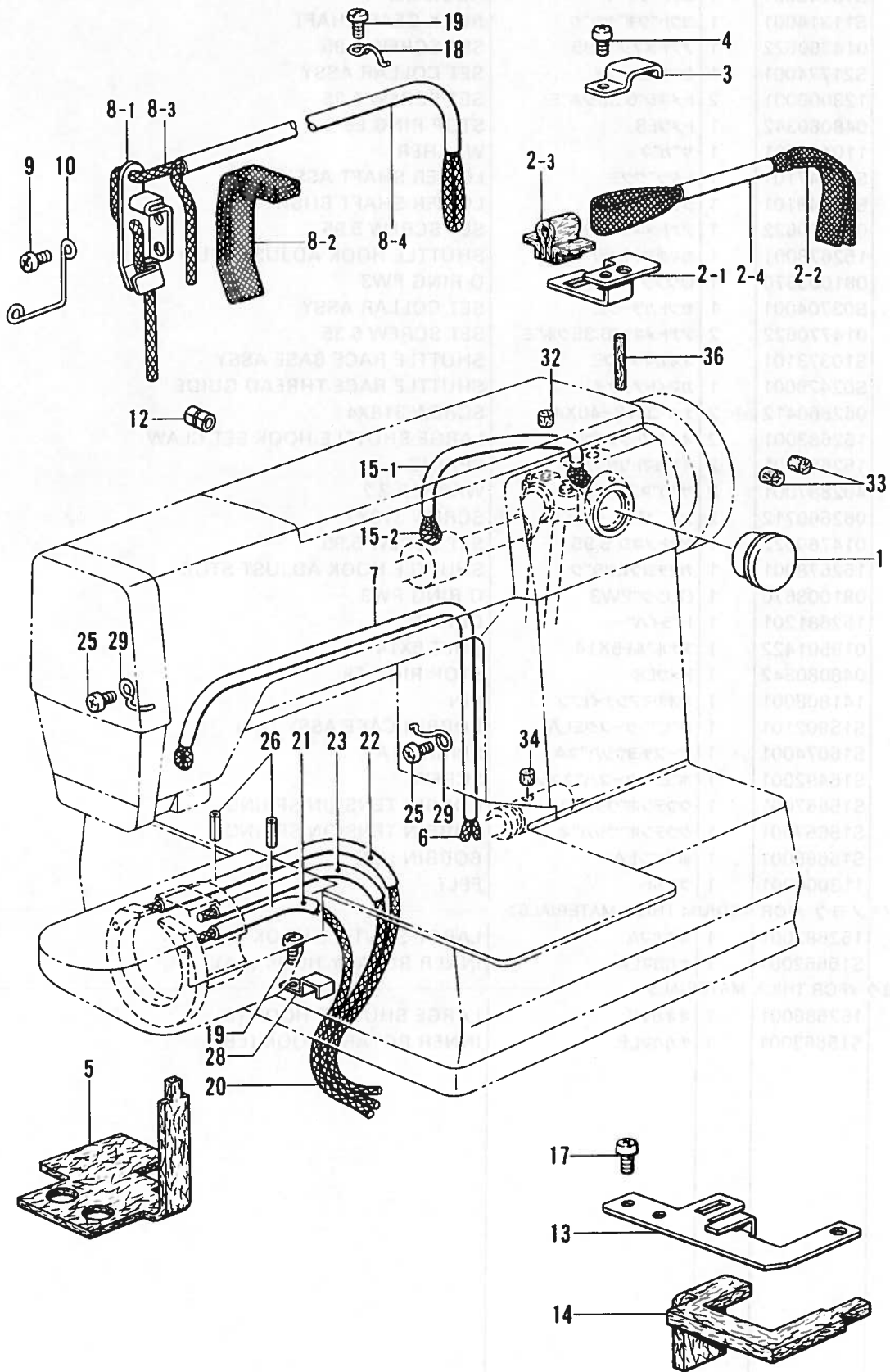

J. 給油・潤滑関係 / Lubrication / Schmierung /
Lubrification / Lubricación

REF. NO.	CODE	Q'TY	ヒンメイ	NAME OF PARTS	RMKS
1	152948001	1	オイルホ"ットマト"	OIL GAUGE WINDOW	
2-1	S10364001	1	ウツシ"クキユウササエ	WICK SUPPORT	
2-2	S10151100	1	ヒラクミヒモL500	FLAT WICK (L=500)	
2-3	S10478000	1	ロツト"キユウフエルト	FELT	
2-4	S10153000	1	ヒ"ニルチューブ"	OIL TUBE	
3	142268001	1	コード"オサエL	CORD HOLDER (L)	
4	062670612	1	ナヘ"コ357-40X6	SCREW 3.57X6	
5	S10155000	1	スイアゲ"フエルト	FELT	
6	S10156000	1	クミヒモ4X4(L=1000)	WICK 4X4 (L=1000)	
7	S10157000	1	ヒ"ニルチューブ"	OIL TUBE	
8-1	S21527001	1	テンヒ"ンキユウササエ	WICK SUPPORT	
8-2	152955001	1	ヒラクミヒモ(L=210)	FLAT WICK (L=210)	
8-3	S10160000	1	クミヒモ4X4(L=800)	WICK 4X4 (L=800)	
8-4	S10161000	1	ヒ"ニルチューブ"	OIL TUBE	
9	062680612	1	ナヘ"コ4.37-40X6	SCREW 4.37X6	
10	S10162001	1	ハリホ"ウヒモササエ	WICK SUPPORT	
12	104567001	1	クミヒモササエ	WICK SUPPORT	
13	S10163001	1	シタシ"クキユウササエ	WICK SUPPORT	
14	S10164000	1	シタシ"クキユウフエルト	FELT	
15	S13559000	1	ナカメタルキユウクミ	OIL ABSORBER ASSY	
15-1	S03662000	1	ヒ"ニルチューブ"	OIL TUBE	
15-2	S10166100	1	ヒラクミヒモL450	FLAT WICK (L=450)	
17	062680812	2	ナヘ"コ437-40X8	SCREW 4.37X8	
18	117150001	1	コード"ササエカネ	CORD SUPPORT	
19	062670612	2	ナヘ"コ357-40X6	SCREW 3.57X6	
20	S10167000	1	クミヒモ4X4(L=200)	WICK 4X4 (L=200)	
21	S10168000	1	ヒ"ニルチューブ"	OIL TUBE	
22	S10353000	1	ヒ"ニルチューブ"	OIL TUBE	
23	S10374000	1	ヒ"ニルチューブ"	OIL TUBE	
25	062670612	2	ナヘ"コ357-40X6	SCREW 3.57X6	
26	047251640	2	スプリング"ピンAW2.5	SPRING PIN AW2.5	
28	155487001	1	フエルトオサエ	FELT SUPPORT	
29	117150001	2	コード"ササエカネ	CORD SUPPORT	
32	107149001	1	フエルト	FELT	
33	107155001	4	フエルト	FELT	
34	107149001	1	フエルト	FELT	
36	106436001	1	フエルト	FELT	

K. 糸通シ関係 / Threading mechanism / FadenführungsVorrichtung /
 Mécanisme de l'enfilage / Mecanismo de la enhebrado

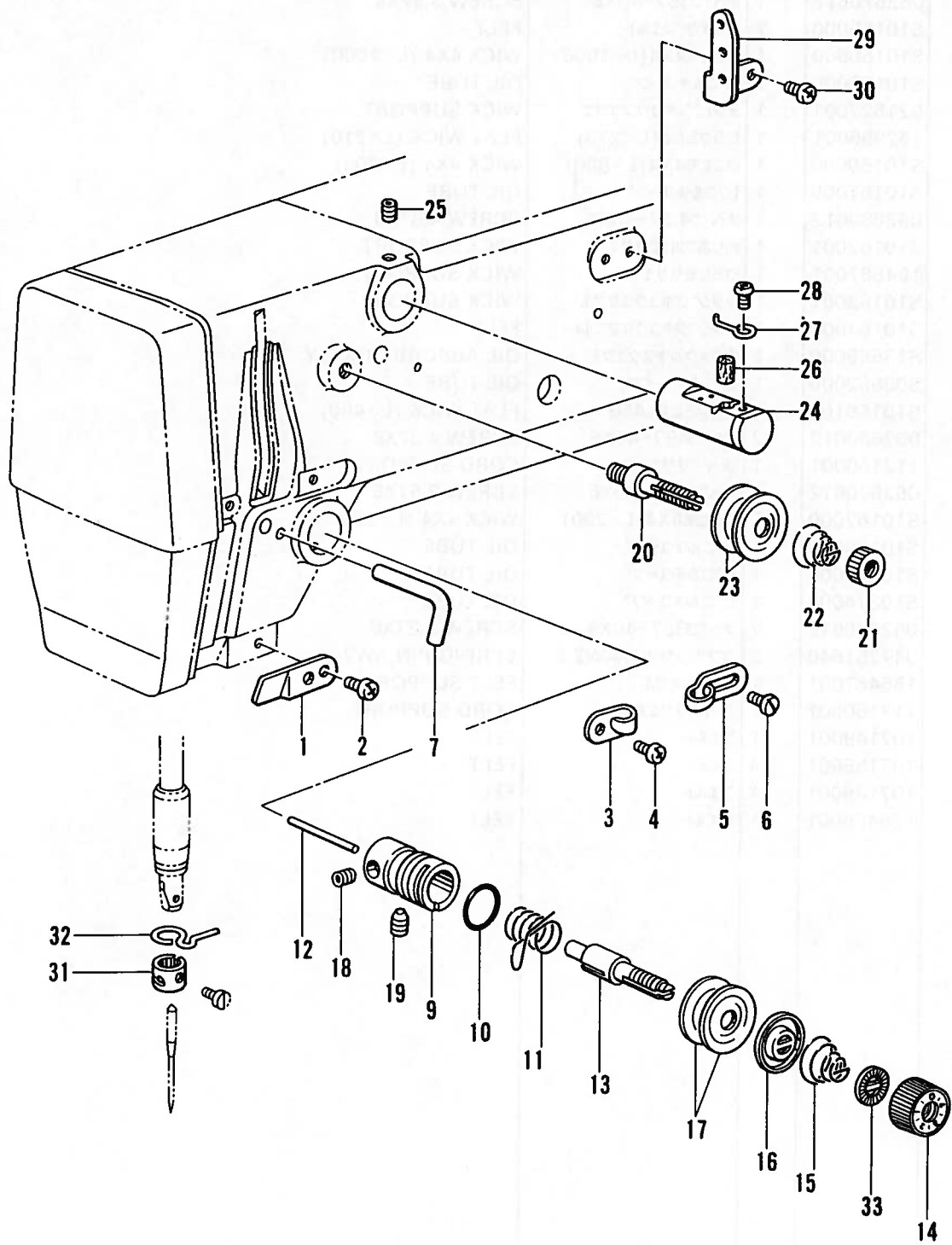

K. 糸通シ関係 / Threading mechanism / Fadenführungsrichtung /
 Mécanisme de l'enfilage / Mecanismo de la enhebrado

REF.NO.	CODE	Q'TY	ヒンメイ	NAME OF PARTS	RMKS
1	152869001	1	アームイトミチ	ARM THREAD GUIDE	
2	062710712	1	ナヘ"コ476-32X7	SCREW 4.76X7	
3	152870001	1	アームイトカケ	ARM THREAD GUIDE	
4	062670612	1	ナヘ"コ357-40X6	SCREW 3.57X6	
5	113316001	1	アームイトアンナイ	ARM THREAD GUIDE	
6	112751003	1	シメネジ"3.57	SCREW 3.57	
7	159224001	1	アームイトカケ	ARM THREAD GUIDE	
9	152872001	1	イトチヨウシダ"イ	TENSION BRACKET	
10	114294001	1	Oリング	O RING	
12	150551000	1	イトユルメピン	PIN	
13	116922001	1	イトチヨウシボ"ウ	TENSION STUD	
14	S11182009	1	イトチヨウシナツクミ	THREAD TENSION NUT ASSY	
16	159805001	1	イトチヨウシサラオサエ	TENSION DISC PRESSER	
17	145446001	2	イトチヨウシサラ	TENSION DISC	
18	100402004	1	トメネジ"3.57	SET SCREW 3.57	
19	S10469001	1	アナトメネジ"5.95	SET SCREW 5.95	
20	115186001	1	シュイトチヨウシボ"ウ	MAIN THREAD TENSION STUD	
21	100136001	1	イトチヨウシナツト	TENSION NUT	
22	115188001	1	シュイトチヨウシハ"ネ	TENSION SPRING	
23	145446001	2	イトチヨウシサラ	TENSION DISC	
24	152881001	1	エキレイタイクミ	NEEDLE COOLER ASSY	
25	013760612	1	トメネジ"5.95クボ"ミ	SET SCREW 5.95	
26	152883000	1	フェルト8X15.5	FELT 8X15.5	
27	152884001	1	エキレイイトカケ	NEEDLE COOLER THREAD GUIDE	
28	062670412	1	ナヘ"コ357-40X4	SCREW 3.57X4	
29	152889001	1	ミツメイトカケ	THREAD RETAINER	
30	062670612	2	ナヘ"コ357-40X6	SCREW 3.57X6	
31-1	S02438001	1	ハリボ"ウイトアンナイA	NEEDLE BAR THREAD GUIDE (A)	
31-2	S02439001	1	ハリボ"ウイトアンナイB	NEEDLE BAR THREAD GUIDE (B)	
32	152891001	1	ハリボ"ウメタルDイトアンナイ	NEEDLE BAR BUSH (D) THREAD GUIDE	
33	S12441001	1	チヨウシハ"ネウエサ"ガ"ネ	WASHER	
<チュウアツモノヨウ /FOR MEDIUM THICK MATERIALS>					
11	145519001	1	イトトリハ"ネ	SPRING	
15	104525001	1	イトチヨウシハ"ネ	TENSION SPRING	
<アツモノヨウ /FOR THICK MATERIALS>					
11	144588001	1	イトトリハ"ネB	SPRING (B)	
15	107606001	1	イトチヨウシハ"ネ	TENSION SPRING	

L. 糸巻関係 / Bobbin winder mechanism / Spuler /
 Mécanisme du bobineur / Mecanismo del devanador de la canilla

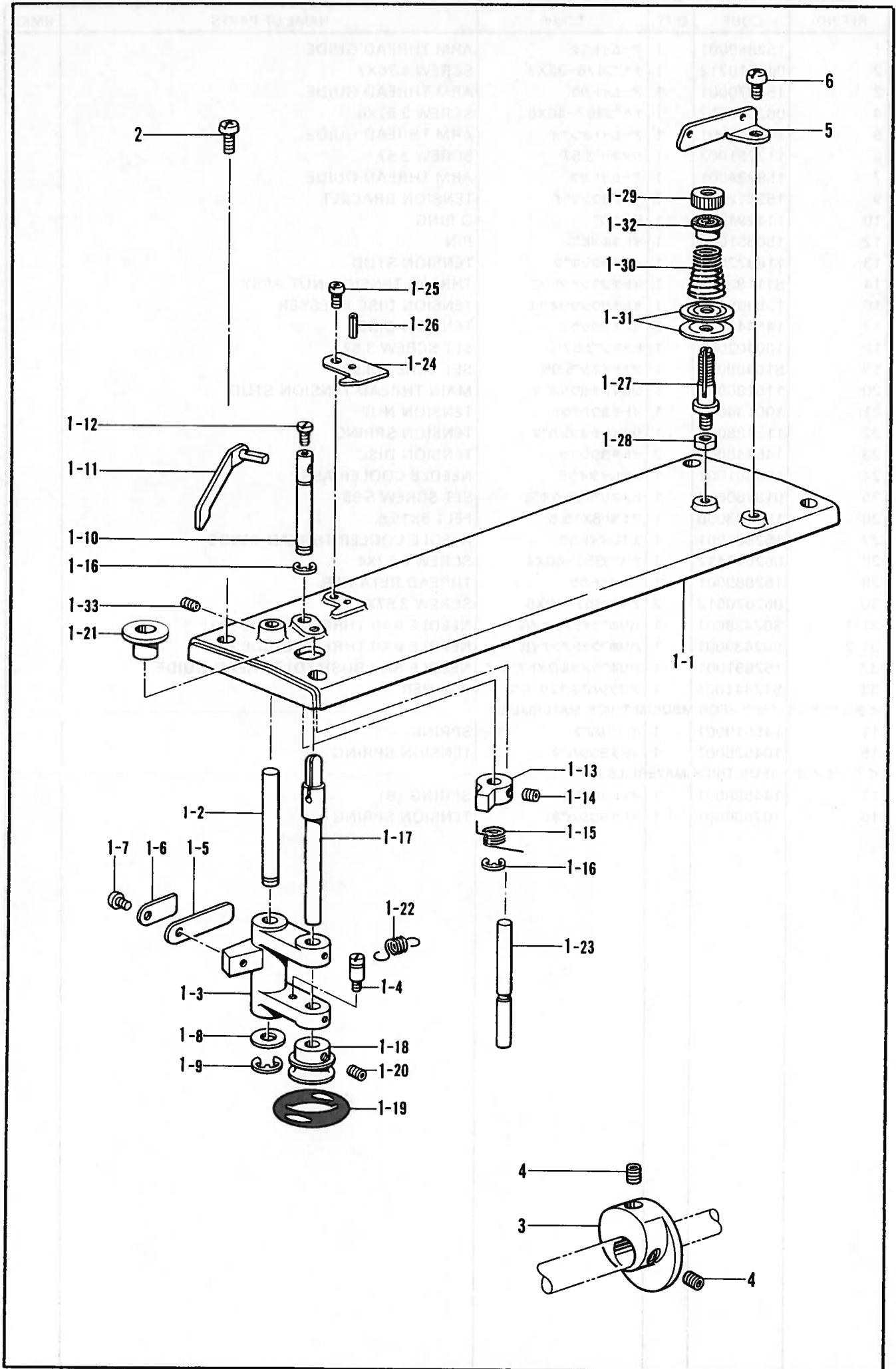

L. 糸巻関係/Bobbin winder mechanism/Spuler/
 Mécanisme du bobineur/Mecanismo del devanador de la canilla

REF.NO.	CODE	Q'TY	ヒンメイ	NAME OF PARTS	RMKS
1-1	S10171002	1	ウフフタ	TOP COVER	
1-2	S10172001	1	イトマキレハ"ー"ジク	BOBBIN WINDER LEVER SHAFT	
1-3	152984001	1	イトマキレハ"ー"	BOBBIN WINDER LEVER	
1-4	141550001	1	テイシレハ"ー"ハ"ネカケ	SPRING HOOK	
1-5	152936001	1	イタハ"ネ	PLATE SPRING	
1-6	152937001	1	サ"ガ"ネ	WASHER	
1-7	062670612	1	ナヘ"コ357-40X6	SCREW 3.57X6	
1-8	159486001	1	サ"ガ"ネ	WASHER	
1-9	048050342	1	トメフE5	STOP RING E5	
1-10	152940001	1	イトマキツメジク	BOBBIN WINDER CLAW STUD	
1-11	S10173001	1	ホ"ビ"ン"オ"サ"エ	BOBBIN PRESSER	
1-12	S01998001	1	アタマツキトメネジ"3.57	SET SCREW 3.57	
1-13	142566001	1	イトマキツメ	BOBBIN WINDER CLAW	
1-14	014680422	2	アタメネジ"4.37クホ"ミ	SET SCREW 4.37	
1-15	S10438001	1	イトマキツメネジ"リハ"ネ	TWIST SPRING	
1-16	048050342	2	トメフE5	STOP RING E5	
1-17	152933001	1	イトマキジク	BOBBIN WINDER SHAFT	
1-18	154528001	1	イトマキクルマ	BOBBIN WINDER WHEEL	
1-19	120448001	1	ゴムフ	RUBBER RING	
1-20	014680422	2	アタメネジ"4.37クホ"ミ	SET SCREW 4.37	
1-21	S10174000	1	ホコリヨケイタ	DUST GUARD PLATE	
1-22	S10268001	1	イトマキウテ"ハ"ネ	SPRING	
1-23	S10175001	1	ストツハ"ジク	STOPPER SHAFT	
1-24	157968001	1	メス	KNIFE	
1-25	062680712	1	ナヘ"コ437-40X7	SCREW 4.37X7	
1-26	047201042	1	スプリング"ヒ"ンAW2	SPRING PIN AW2	
1-27	159574101	1	イトチヨウシホ"ウ	TENSION STUD	
1-28	021680202	1	ナツト2シユ4.37	NUT 4.37	
1-29	100136001	1	イトチヨウシナツト	TENSION NUT	
1-30	144110001	1	シタル"ハ"イトチヨウシハ"ネ	TENSION SPRING	
1-31	145446001	2	イトチヨウシサラ	TENSION DISC	
1-32	144105000	1	チヨウシハ"ネウエサ"ガ"ネ	SPRING WASHER	
1-33	148294001	1	アタメネジ"3.57クホ"ミ	SET SCREW 3.57	
2	062711212	4	ナヘ"コ476-32X12	SCREW 4.76X12	
3	S18520100	1	イトマキプ"ー"リ	BOBBIN WINDER PULLEY	
4	014760622	2	アタメネジ"5.95	SET SCREW 5.95	
5	115183101	1	イトカケ	THREAD GUIDE	
6	062711012	1	ナヘ"コ476-32X10	SCREW 4.76X10	

M. 糸切り関係 / Thread trimmer mechanism / Fadenabschneidevorrichtung /
 Mécanisme de coupe-fil / Mecanismo de recortadora de orillos

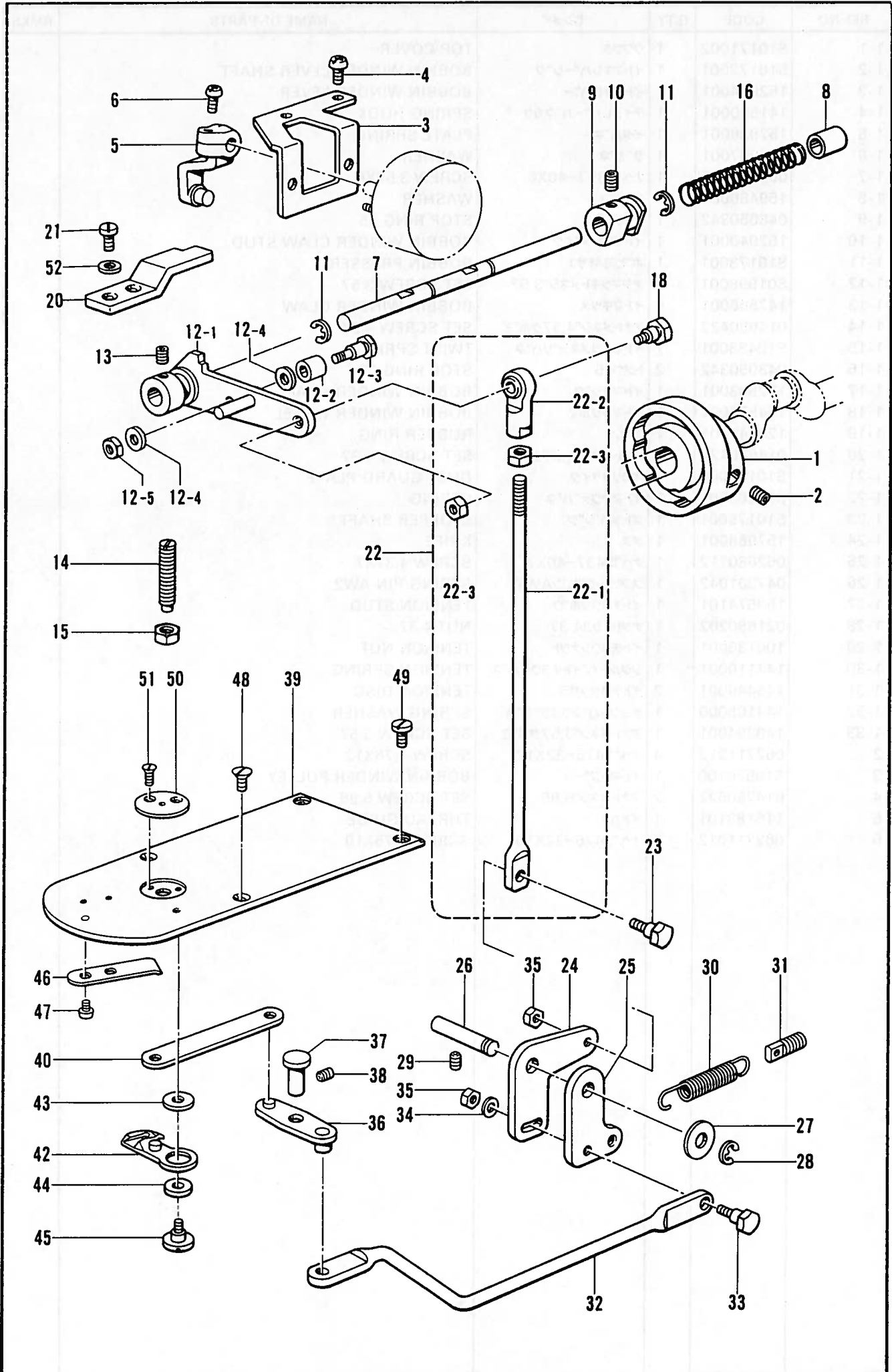

M. 糸切り関係/Thread trimmer mechanism/Fadenabschneidevorrichtung/
Mécánisme de coupe-fil/Mecanismo de recortadora de orillos

REF.NO.	CODE	Q'TY	ヒンメイ	NAME OF PARTS	RMKS
1	S18653001	1	イトキリカム	THREAD TRIMMER CAM	
2	014770622	2	アナトメネシ"6.35クホ"ミ	SET SCREW 6.35	
3	S10178001	1	ソレノイト"トリツケイタ	SOLENOID SET PLATE	
4	062681012	2	ナヘ"ユ437-40X10	SCREW 4.37X10	
5	S10179001	1	ソレノイト"レハ"ークミ	SOLENOID LEVER ASSY	
6	062671012	1	ナヘ"ユ357-40X10	SCREW 3.57X10	
7	S10182101	1	クト"ウレハ"ーアンナイジ"ク	DRIVING LEVER SHAFT	
8	231071001	1	メタル8X15	BUSH 8X15	
9	S18919001	1	クト"ウシ"クカラー	DRIVING LEVER COLLAR	
10	014760622	2	アナトメネシ"5.95	SET SCREW 5.95	
11	048070342	2	トメフE7	STOP RING E7	
12	S30114001	1	イトキリクト"ウレハ"ソウクミ	THREAD TRIMMER DRIVING LEVER ASSY	
12-1	S30115001	1	イトキリクト"ウレハ"ークミ	THREAD TRIMMER DRIVING LEVER ASSY	
12-2	153597001	1	シタイトサハ"キカラー	LOWER THREAD RETAINER COLLAR	
12-3	S30033001	1	タ"ンネシ"3.57	STUD SCREW 3.57	
12-4	148813001	2	サ"カ"ネ	WASHER	
12-5	106129002	1	ナツト3.57	NUT3.57	
13	014770622	1	アナトメネシ"6.35クホ"ミ	SET SCREW 6.35	
14	159905001	1	トメヌイチヨウセツネシ"	ADJUST SCREW	
15	106147002	1	ナツト7.94	NUT 7.94	
16	S10189001	1	クト"ウシ"クモト"シハ"ネ	SPRING	
18	S02354001	1	タマツキ"テタ"ンネシ"B	STUD SCREW (B)	
20	S10190001	1	クト"ウレハ"ーストツハ"	DRIVING LEVER STOPPER	
21	107093002	2	シメネシ"4.37	SCREW 4.37	
22	S10267001	1	イトキリロツト"Sクミ	THREAD TRIMMER ROD (S) ASSY	
22-1	S10191001	1	イトキリロツト"S	THREAD TRIMMER ROD (S)	
22-2	141492001	1	タマツキ"テクミ	JOINT ASSY	
22-3	106588003	2	ナツト5.95	NUT 5.95	
23	S10192001	1	タ"ンネシ"4.37	STUD SCREW 4.37	
24	S10193001	1	イトキリレハ"ーD	THREAD TRIMMER LEVER (D)	
25	S10194001	1	イトキリレハ"ーU	THREAD TRIMMER LEVER (U)	
26	S10195001	1	イトキリレハ"ージ"ク	LEVER SHAFT	
27	110367001	1	サ"カ"ネ	WASHER	
28	048060342	1	トメフE6	STOP RING E6	
29	014760622	1	アナトメネシ"5.95	SET SCREW 5.95	
30	S10196101	1	イトキリレハ"ーヒキハ"ネ	SPRING	
31	110146001	1	チヨウセツキハ"ネカケS	SPRING HOOK (S)	
32	S10197001	1	イトキリロツト"L	THREAD TRIMMER ROD (L)	
33	S10192001	1	タ"ンネシ"4.37	STUD SCREW 4.37	
34	025680232	1	ヒラサ"カ"ネチユウ4.37	PLAIN WASHER 4.37	
35	021680202	2	ナツト2シユ4.37	NUT 4.37	
36	S10198001	1	レンカンレハ"ークミ	CONNECTING ROD LEVER ASSY	
37	S10202001	1	レンカンレハ"ーシ"ク	CONNECTING ROD LEVER SHAFT	
38	014680622	1	アナトメネシ"4.37クホ"ミ	SET SCREW 4.37	
39	S10203001	1	ハリイタ	NEEDLE PLATE	
40	S10204101	1	イトキリレンカン	THREAD TRIMMER CONNECTING ROD	
42	S10205001	1	イト"ウハクミ	MOVABLE KNIFE ASSY	
43	S10208001	1	イト"ウハカンサ"ーT=0.4	WASHER T=0.4	
43	S10208002	1	イト"ウハカンサ"ーT=0.5	WASHER T=0.5	
43	S10208003	1	イト"ウハカンサ"ーT=0.6	WASHER T=0.6	
44	S00705001	1	イト"ウハカラー	MOVABLE COLLAR	
45	S10209101	1	シメネシ"4.37	SCREW 4.37	
46	S10210101	1	コテイハ	FIXED KNIFE	
47	111140002	2	シメネシ"2.38	SCREW 2.38	
48	100032004	2	サラネシ"4.37	SCREW 4.37	
49	153208002	1	シメネシ"4.37	SCREW 4.37	
50	S10213001	1	ハリアナイタF	NEEDLE HOLE PLATE (F)	
51	100360003	2	サラネシ"2.38	SCREW 2.38	
52	025680132	2	ヒラサ"カ"ネシヨウ4.37	PLAIN WASHER 4.37	

N. 糸締メ関係 / Thread nipper mechanism / Fadenspannvorrichtung /
 Mécanisme de pince-fil / Mecanismo de mordaza para hilos

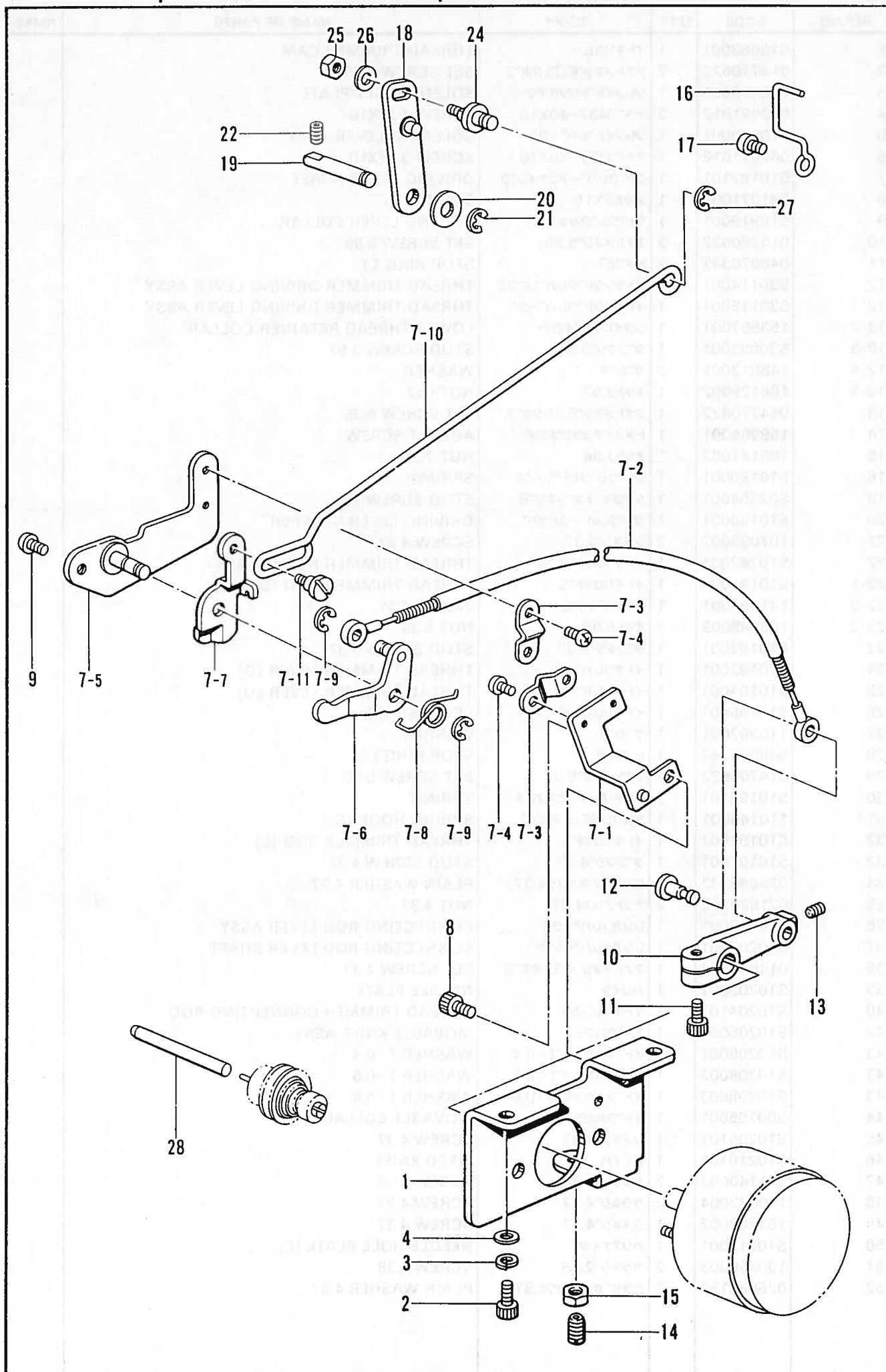

N. 糸締メ関係 / Thread nipper mechanism / Fadenspannvorrichtung /
 Mécanisme de pince-fil / Mecanismo de mordaza para hilos

REF.NO.	CODE	Q'TY	ヒンメイ	NAME OF PARTS	RMKS
1	S10219001	1	ソレノイド"トリツケイタ	SOLENOID SET PLATE	
2	018061422	2	アナボ"ルト6X14	BOLT 6X14	
3	028060242	2	ハ"ネサ"カ"ネ2-6	SPRING WASHER 2-6	
4	025060232	2	ヒラサ"カ"ネチユウ6	PLAIN WASHER 6	
7	S10220101	1	イトユルメクミ	TENSION RELEASE ASSY	
7-1	S10221001	1	ワイヤササエ	WIRE SUPPORT	
7-2	S10222001	1	オサエアケ"ワイヤクミ	WORK CLAMP LIFTER WIRE ASSY	
7-3	154607001	2	イトユルメワイヤー"オサエD	TENSION RELEASE WIRE HOLDER (D)	
7-4	062670612	4	ナヘ"コ357-40X6	SCREW 3.57X6	
7-5	S10224001	1	イトユルメフ"ラケツト	TENSION RELEASE BRACKET	
7-6	S10225001	1	オサエアシアケ"レハ"ークミ	WORK CLAMP LIFTER LEVER ASSY	
7-7	S10228001	1	イトユルメレハ"ー	TENSION RELEASE LEVER	
7-8	S10229101	1	オサエレハ"ー"ハ"ネ	SPRING	
7-9	048040342	2	トメフE4	STOP RING E4	
7-10	S10237001	1	イトユルメロツト"	TENSION RELEASE ROD	
7-11	155611001	1	タ"ンネシ"4.37	STUD SCREW 4.37	
8	018060822	1	アナボ"ルト6X8	BOLT 6X8	
9	062771012	1	ナヘ"コ635-40X10	SCREW 635X10	
10	S10230000	1	オサエアケ"ンハ"ー	WORK CLAMP LIFTER LEVER	
11	018501422	1	アナボ"ルト5X14	BOLT 5X14	
12	S10231001	1	ツハ"ツキシ"ク5.5	FLANGED SHAFT 5.5	
13	014680622	1	アナトメネシ"4.37クホ"ミ	SET SCREW 4.37	
14	150817101	1	ハリボ"ウアテ	NEEDLE BAR PUSHER	
15	106147002	1	ナツト7.94	NUT 7.94	
16	S10232001	1	ケーブ"ルササエ	CABLE SUPPORT	
17	062760812	1	ナヘ"コ595-28X8	SCREW 595X8	
18	S10233101	1	オサエロツト"レハ"ークミ	PRESSER ROD LEVER ASSY	
19	S10236001	1	ロツト"レハ"ー"ジ"ク	ROD LEVER SHAFT	
20	110367001	1	サ"カ"ネ	WASHER	
21	048060342	1	トメフE6	STOP RING E6	
22	014760622	2	アナトメネシ"5.95	SET SCREW 5.95	
24	S10238001	1	タ"ンシ"ク	STUD SHAFT	
25	021680212	1	ナツト2シユ4.37	NUT 4.37	
26	100645003	1	サ"カ"ネ	WASHER	
27	048040342	1	トメフE4	STOP RING E4	
28	S10239001	1	イトユルメホ"ウ	TENSION RELEASE BAR	

P. 電装品関係/Power supply equipment mechanism/Schaltkasten/
 Mécanisme de l'équipement en alimentation électrique/Mecanismo de la equipo de alimentación de corriente

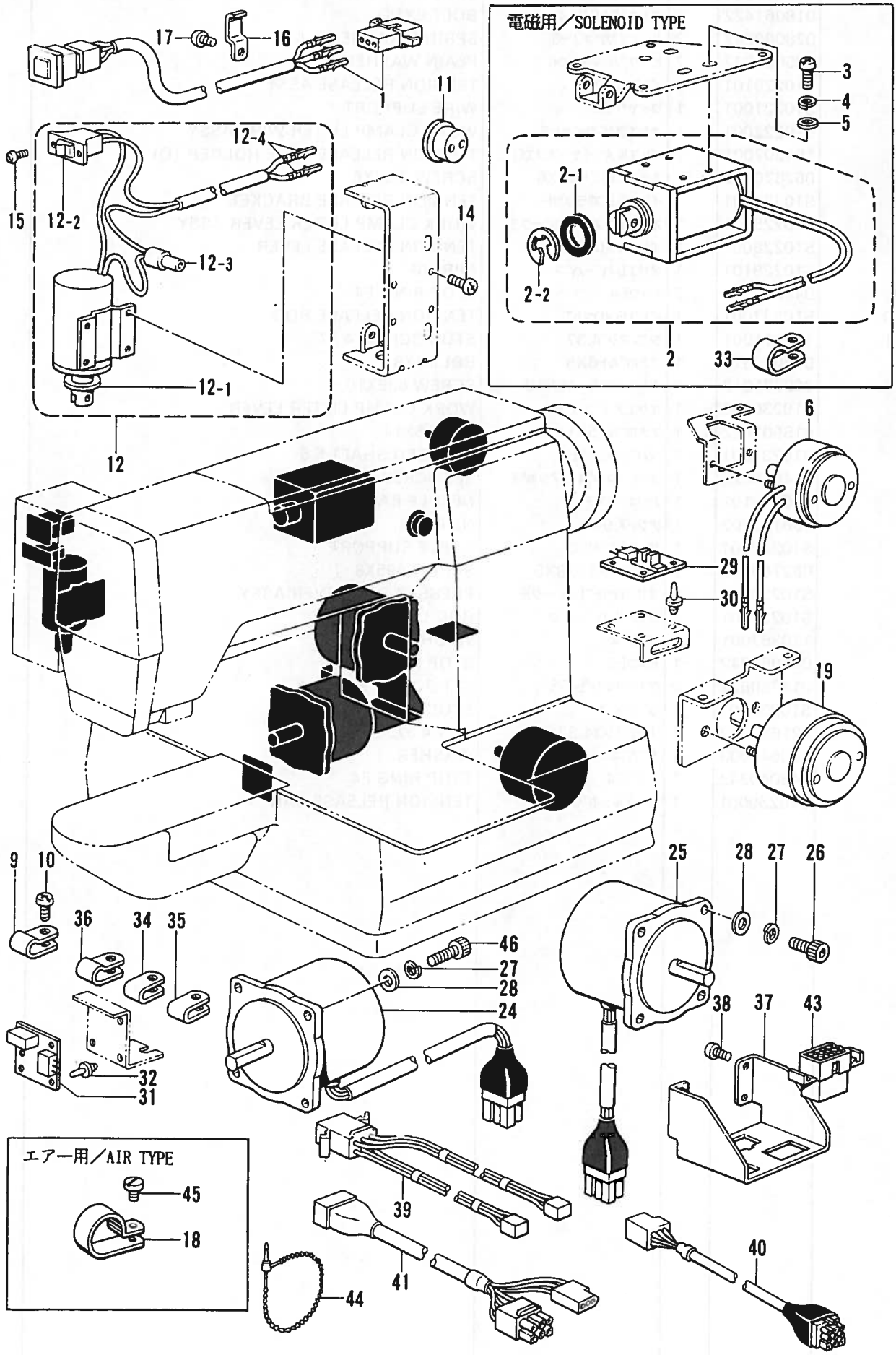

P. 電装品関係 / Power supply equipment mechanism / Schaltkasten /
 Mécanisme de l'équipement en alimentation électrique / Mecanismo de la equipo de alimentación de corriente

REF.NO.	CODE	Q'TY	ヒンメイ	NAME OF PARTS	RMKS
1	S10240009	1	EMスイッチクミ	EM-SWITCH ASSEMBLY	
6	S10242000	1	イトキソソレノイト"	THREAD TIMMING SOLENOID	
9	S10243000	1	ナイロンクランプ"NK-3N	CORD HOLDER NK-3N	
10	062670612	1	ナヘ"コ357-40X6	SCREW 3.57X6	
11	146020009	1	コート"フ"シユ	CORD BUSH	
12	S10367009	1	イトハラソソレノイト"クミ	THREAD WIPER SOLENOID ASSY	
12-1	159947001	1	ストップ"レハ"-サ"カ"ネ	WASHER	
12-2	S02664001	1	イトハラスイツチ	THREAD WIPER SWITCH	
12-3	S02665000	1	ヘイタンセツゾ"クシ	CONNECTOR	
12-4	143549000	2	ヒンター-ミナルオス	TERMINAL PIN (MALE)	
14	062670612	4	ナヘ"コ357-40X6	SCREW 3.57X6	
15	062300612	2	ナヘ"コ3X6	SCREW 3X6	
16	142268001	3	コート"オサEL	CORD HOLDER (L)	
17	062670612	3	ナヘ"コ357-40X6	SCREW 3.57X6	
19	S10244000	1	カンケツソレノイト"	INTERMITENT SOLENOID	
24	S10365001	1	ハ"ルスモータXクミ	X-PULSE MOTOR ASSY	
25	S10366001	1	ハ"ルスモータYクミ	Y-PULSE MOTOR ASSY	
26	018501222	4	アナホ"ルト5X12	BOLT 5X12	
27	028050242	8	ハ"ネサ"カ"ネ2-5	SPRING WASHER 2-5	
28	025050232	8	ヒラサ"カ"ネチユウ5	PLAIN WASHER 5	
29	S10245001	1	Yケンテンキハ"ン	Y-AXIS HOME POSITION CIRCUIT BOARD	
30	S10246000	4	フアスナー	FASTENER	
31	S02917001	1	ケンテンキハ"ン	HOME POSITION CIRCUIT BOARD	
32	S10246000	3	フアスナー	FASTENER	
34	625010000	2	ナイロンクランプ"NK-2N	CORD HOLDER NK-2N	
35	625010000	2	ナイロンクランプ"NK-2N	CORD HOLDER NK-2N	
36	S10243000	1	ナイロンクランプ"NK-3N	CORD HOLDER NK-3N	
37	S10370001	1	コネクタトリツケイタ	CONNECTOR SET PLATE	
38	062680812	4	ナヘ"コ437-40X8	SCREW 4.37X8	
39	S10247001	1	ケンテンハーネス	HOME POSITION HARNESS	
40	S30284001	1	ソレノイト"ハーネス311A	SOLENOID HARNESS (311A)	
41	S10249001	1	マシンヘッド"ハーネスA	MACHINE HEAD HARNESS (A)	
43	S10468000	1	コネクタ1360P三ミツキ	CONNECTOR 1360P	
44	340400001	5	ユニタイハ"ント"	BEAD BAND	
46	018501422	4	アナホ"ルト5X14	BOLT 5X14	
<デンジヨウ /SOLENOID TYPE>					
2	S10241001	1	オサエソレノイト"	PRESSER SOLENOID	
2-1	S29124000	1	ゴムストップハー	RUBBER STOPPER	
2-2	154730001	1	トメワE15	STOP RING E15	
3	062401012	4	ナヘ"コM4X10	SCREW M4X10	
4	028040242	4	ハ"ネサ"カ"ネ2-4	SPRING WASHER 2-4	
5	025040232	4	ヒラサ"カ"ネチユウ4	PLAIN WASHER 4	
33	146202000	1	ナイロンクリップ	NYLON CLIP	
<エア-ヨウ /AIR TYPE>					
18	554482000	1	コート"ホルタ"#12	CORD HOLDER (12N)	
45	112751003	1	シメネジ"3.57	SCREW 3.57	

Q. 針位置検出器関係 / Synchronizer / Synchronisator / Synchronisateur / Sincronizador

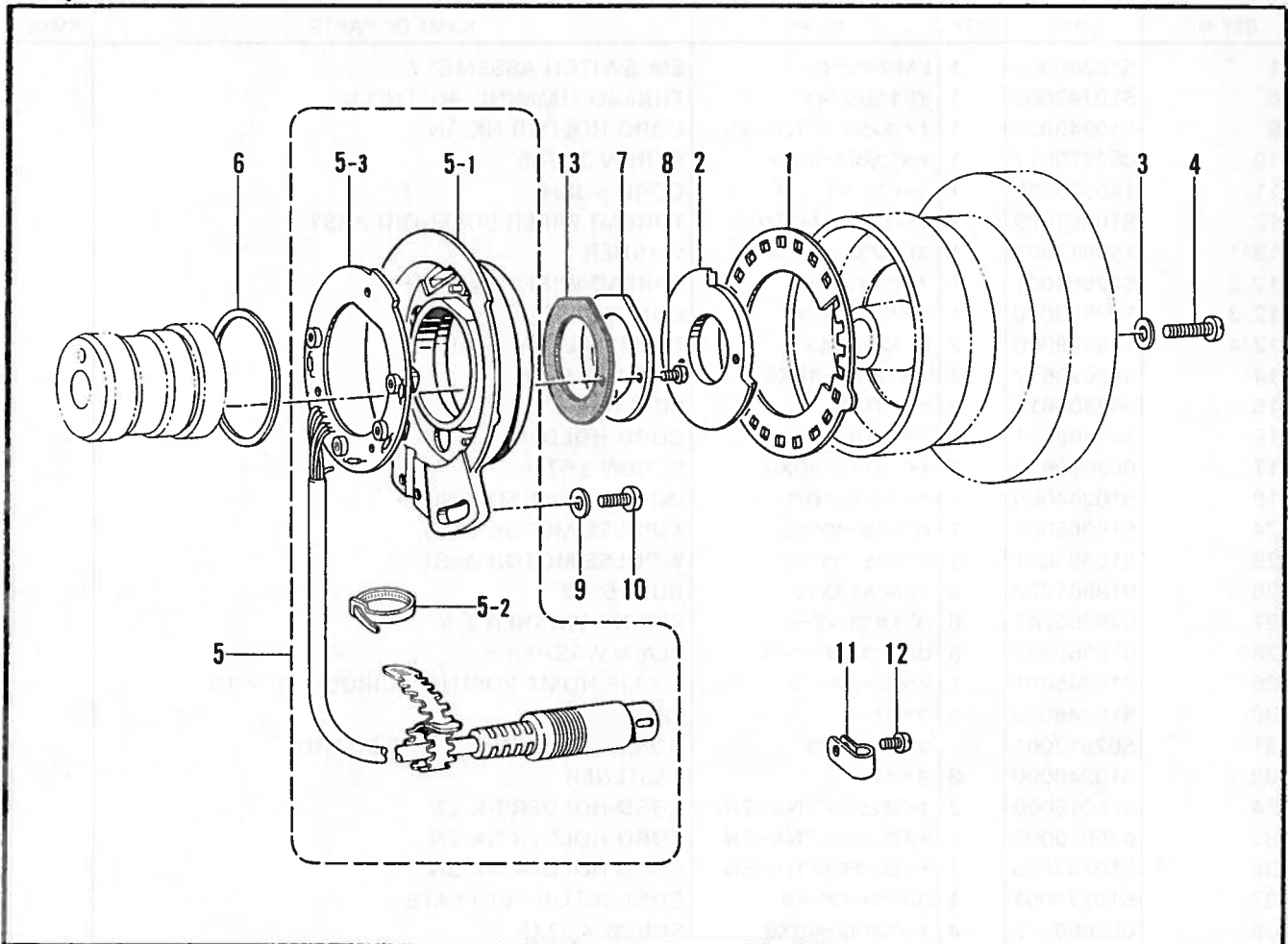

R. プリント基板関係 / Printed circuit board mechanism / Leiterplatten / Circuits imprimés / Tableros de circuitos impresos

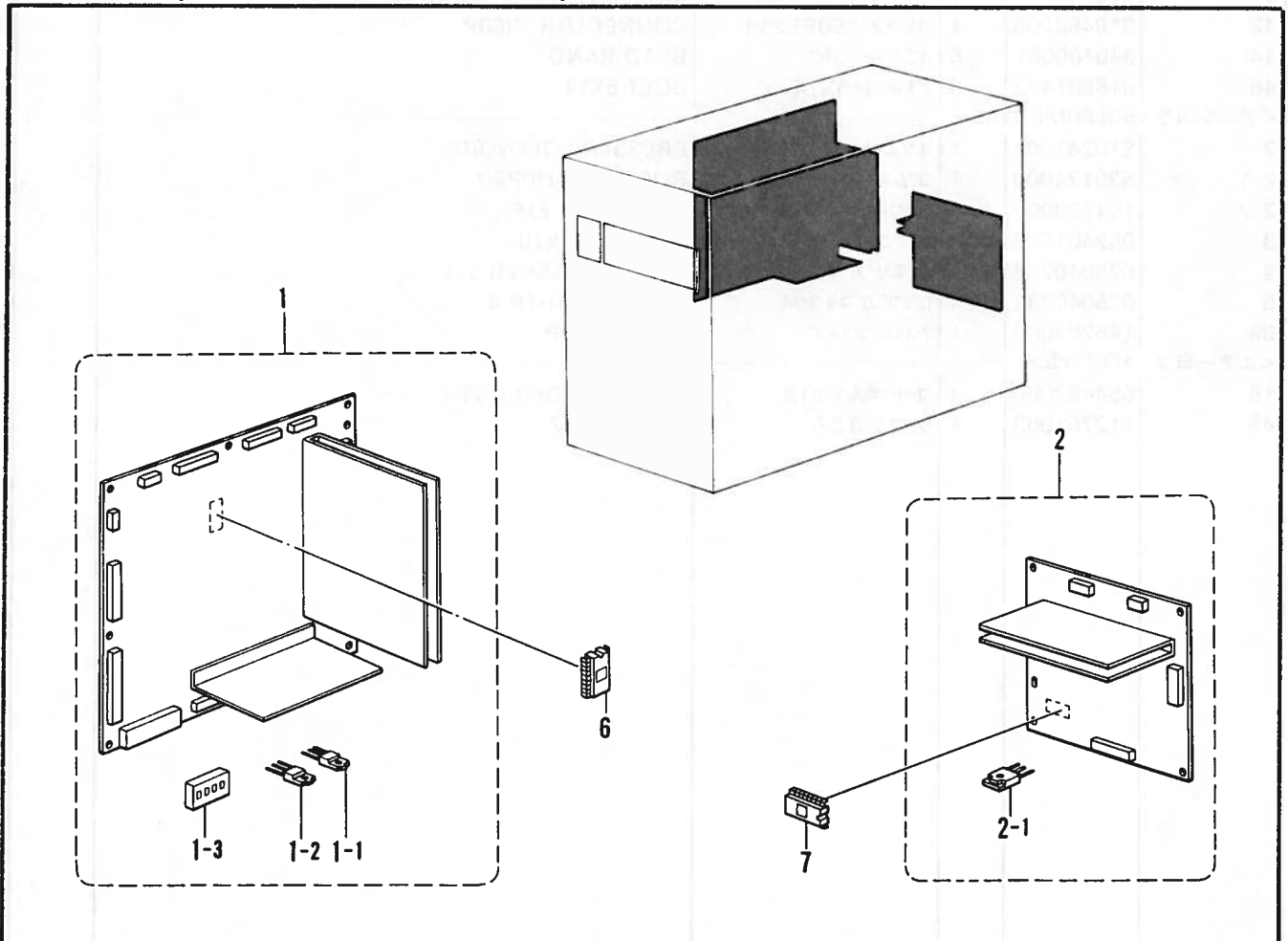

Q. 針位置検出器関係/Synchronizer/Synchronisator/
Synchronisateur/Sincronizador

REF. NO.	CODE	Q'TY	ヒンメイ	NAME OF PARTS	RMKS
1	S02684001	1	ソクト"シレイイタ24	SPEED COMMAND PLATE 24	
2	S02685001	1	ハリウエイタ	NEEDLE UPPER PLATE	
3	100645003	2	ザ"ガ"ネ	WASHER	
4	062681612	2	ナヘ"コ437-40X16	SCREW 4.37X16	
5	237941001	1	シンクロナイザ"クミ#13G7	SYNCHRONIZER ASSY #13G7	
5-1	228474000	1	キハ"ンウケ	CIRCUIT BOARD BRACKET	
5-2	228475000	1	ケツソクハ"ント"1.9X80	TYING BAND 1.9X80	
5-3	238033001	1	SYキハ"ンクミG3	SY-CIRCUIT BOARD ASSY G3	
6	S03327000	1	シンクロナイザ"ハ"ツキン	SYNCHRONIZER PACKING	
7	S02687201	1	ケンシユツキオサエ	SYNCHRONIZER SUPPORT	
8	062630712	2	ナヘ"コ238-56X7	SCREW 238X7	
9	113431002	1	ザ"ガ"ネ	WASHER	
10	062711012	1	ナヘ"コ476-32X10	SCREW 4.76X10	
11	149547000	2	コト"オサエ	CORD HOLDER (4N)	
12	062670612	2	ナヘ"コ357-40X6	SCREW 3.57X6	
13	S07885000	1	ケンシユツキオサエハ"ツキン	SYNCHRONIZER SUPPORT PACKING	

R. プリント基板関係/Printed circuit board mechanism/Leiterplatten/
Circuits imprimés/Tableros de circuitos impresos

REF. NO.	CODE	Q'TY	ヒンメイ	NAME OF PARTS	RMKS
1	S29007001	1	メインキハ"ンクミ	MAIN CIRCUIT BOARD ASSY	
1-1	U31357000	8	SITR2SB951A	SILICON TRANSISTOR 2SB951A	
1-2	U31359000	12	SITR2SD1277B	SILICON TRANSISTOR 2SD1277B	
1-3	T22706000	1	DIPSW KSD04	DIPSW KSD04	
2	S29008001	1	モータキハ"ンクミ	MOTOR CIRCUIT BOARD ASSY	
2-1	S30206000	6	MOSFET2SK1936	MOSFET2SK1936	
6	S30253001	1	PROMセイキ"ヨクミ	PROM CONTROL ASSY	
7	S30254001	1	PROMモータクミ	PROM MOTOR ASSY	

S. コントロールボックス関係 / Control box mechanism / Stromversorgung /
 Mécanisme du boîtier de contrôle / Mecanismo del caja de controles

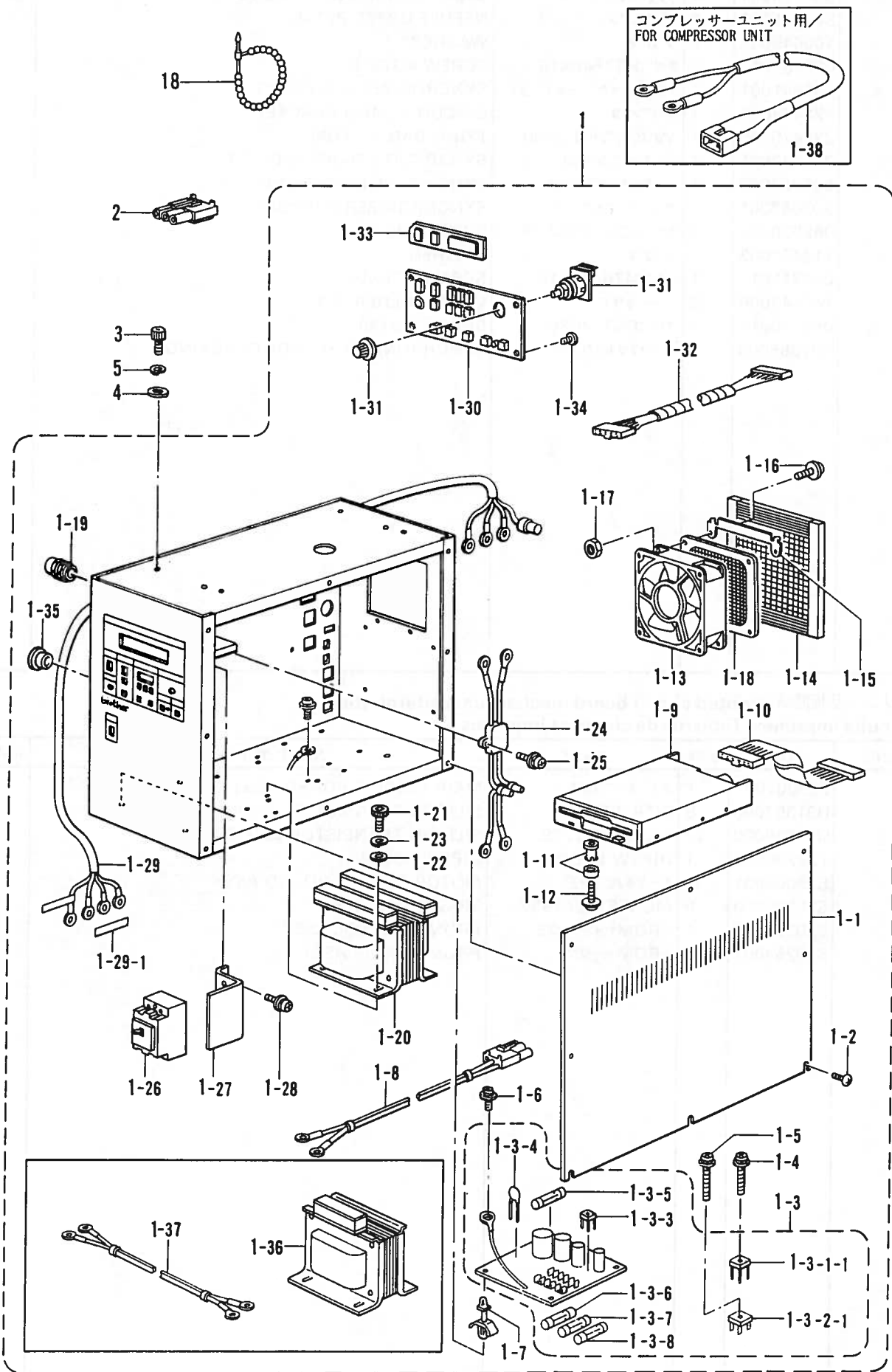

S. コントロールボックス関係 / Control box mechanism / Stromversorgung /
 Mécanisme du boîtier de contrôle / Mecanismo del caja de controles

REF.NO.	CODE	Q'TY	ヒンメイ	NAME OF PARTS	RMKS
<200V, 220V>					
1	S31158109	1	ホ"ツクス304AクミA	BOX 304A ASSY (A)	
1-8	S30249001	1	フィルタINコート"クミ	FILTER IN CORD ASSY	
1-20	S30232000	1	トランス300A	TRANSFORMER 300A	
1-24	S30250001	1	ノイズ"フィルター-3A	NOISE FILTER (3A)	
1-26	S21181000	1	ブ"レーカー-F5A	BREAKER (F5A)	
1-29	S30238001	1	デ"ンゲ"ンコード"	POWER SUPPLY CORD	
1-29-1	S31650000	1	セツメイシール	DIAGRAM SEAL	
<100V, 110V>					
1	S31159109	1	ホ"ツクス304AクミB	BOX 304A ASSY (B)	
1-8	S30282001	1	フィルタINコート"クミBC	FILTER IN CORD ASSY	
1-20	S30233000	1	トランス300B	TRANSFORMER 300B	
1-24	S30264001	1	ノイズ"フィルター-5A	NOISE FILTER (5A)	
1-26	S21504000	1	ブ"レーカー-F10A	BREAKER (F10A)	
1-29	S31585001	1	デ"ンゲ"ンコード"コクナイ	POWER SUPPLY CORD FOR DOMESTIC	
1-36	S30285000	1	ヘンカントランスB	CONVERSION TRANSFORMER (B)	
1-37	S30281001	1	トランスコード"	TRANSCORD	
<380V, 415V>					
1	S31160109	1	ホ"ツクス304AクミC	BOX 304A ASSY (C)	
1-8	S30282001	1	フィルタINコート"クミBC	FILTER IN CORD ASSY	
1-20	S30234000	1	トランス300C	TRANSFORMER 300C	
1-24	S30250001	1	ノイズ"フィルター-3A	NOISE FILTER (3A)	
1-26	S21181000	1	ブ"レーカー-F5A	BREAKER (F5A)	
1-29	S30238001	1	デ"ンゲ"ンコード"	POWER SUPPLY CORD	
1-29-1	S31650000	1	セツメイシール	DIAGRAM SEAL	
1-36	S30286000	1	ヘンカントランスC	CONVERSION TRANSFORMER (C)	
1-37	S30281001	1	トランスコード"	TRANSCORD	
<タンソウヨウ 200V, 240V / SINGLE-PHASE 200V, 240V>					
1	S31163109	1	ホ"ツクス304AクミF	BOX 304A ASSY (F)	
<コンプレッサーヨウ 200V>					
1	S31161109	1	ホ"ツクス304AクミD	-----	
1-38	S10465001	1	コンプレッサーハーネス	-----	
<コンプレッサーヨウ 100V>					
1	S31162109	1	ホ"ツクス304AクミE	-----	
1-38	S10465001	1	コンプレッサーハーネス	-----	
1-1	S18507101	1	ホ"ツクスフタ	BOX COVER	
1-2	008400604	6	+トラスコ4X6	SCREW 4X6	
1-3	S29009001	1	デ"ンゲ"ンキハ"ンクミ	POWER SUPPLY CIRCUIT BOARD ASSY	
1-3-1-1	S08032000	1	SIBRS10VB60	SIBRS10VB60	
1-3-1-2	S10315000	2	SIBRS15VB10	SIBRS15VB10	
1-3-3	S30224000	1	SIDS3WB10	SIDS3W10	
1-3-4	S30227000	1	ZNRC20DK391	ZNRC20DK391	
1-3-5	S08030000	1	Gヒューズ"5AFB	G FUSE (5AFB)	
1-3-6	S02887000	1	ヒューズ"15A	FUSE (15A)	
1-3-7	152565000	1	ヒューズ"B	FUSE (B)	
1-3-8	152566000	1	ヒューズ"C	FUSE (C)	
1-4	0A4301605	1	+ナヘ"サ"クミ3X16DA	SCREW SET 3X16DA	
1-5	0A5402005	2	+ナヘ"サ"クミ4X20DB	SCREW SET 4X20DB	
1-6	0A5401005	1	+ナヘ"サ"クミ4X10DB	SCREW SET 4X10DB	
1-7	S00554000	17	サポ"ト6NS	SUPPORT 6NS	
1-9	S16661001	1	3.5フロッピー"ト"ドライブ"	3.5 INCH FLOPPY DRIVE	
1-10	S10283001	1	フロッピー"ハーネス	FLOPPY HARNESS	
1-11	S18573000	4	ワンタッチカラー"フ"ツシユ	ONE-TOUCH COLLAR BUSH	
1-12	0A5301405	4	+ナヘ"サ"クミ3X14DB	SCREW SET 3X14DB	
1-13	S16566000	1	クー"リング"ファン	COOLING FAN	
1-14	S10336000	1	ファン"ガード"	FAN GUARD	
1-15	S10289000	2	ファン"トリツケ"カナガ"	FAN SET PLATE	
1-16	0A5301205	8	+ナヘ"サ"クミ3X12DB	SCREW SET 3X12DB	
1-17	021300206	4	2"シユナツト3	NUT 3	
1-18	S16567000	1	ファン"フィルター"	FAN FILTER	
1-19	152510000	2	コード"フ"ツシユ	CORD BUSH	

S. コントロールボックス関係 / Control box mechanism / Stromversorgung /
 Mécanisme du boîtier de contrôle / Mecanismo del caja de controles

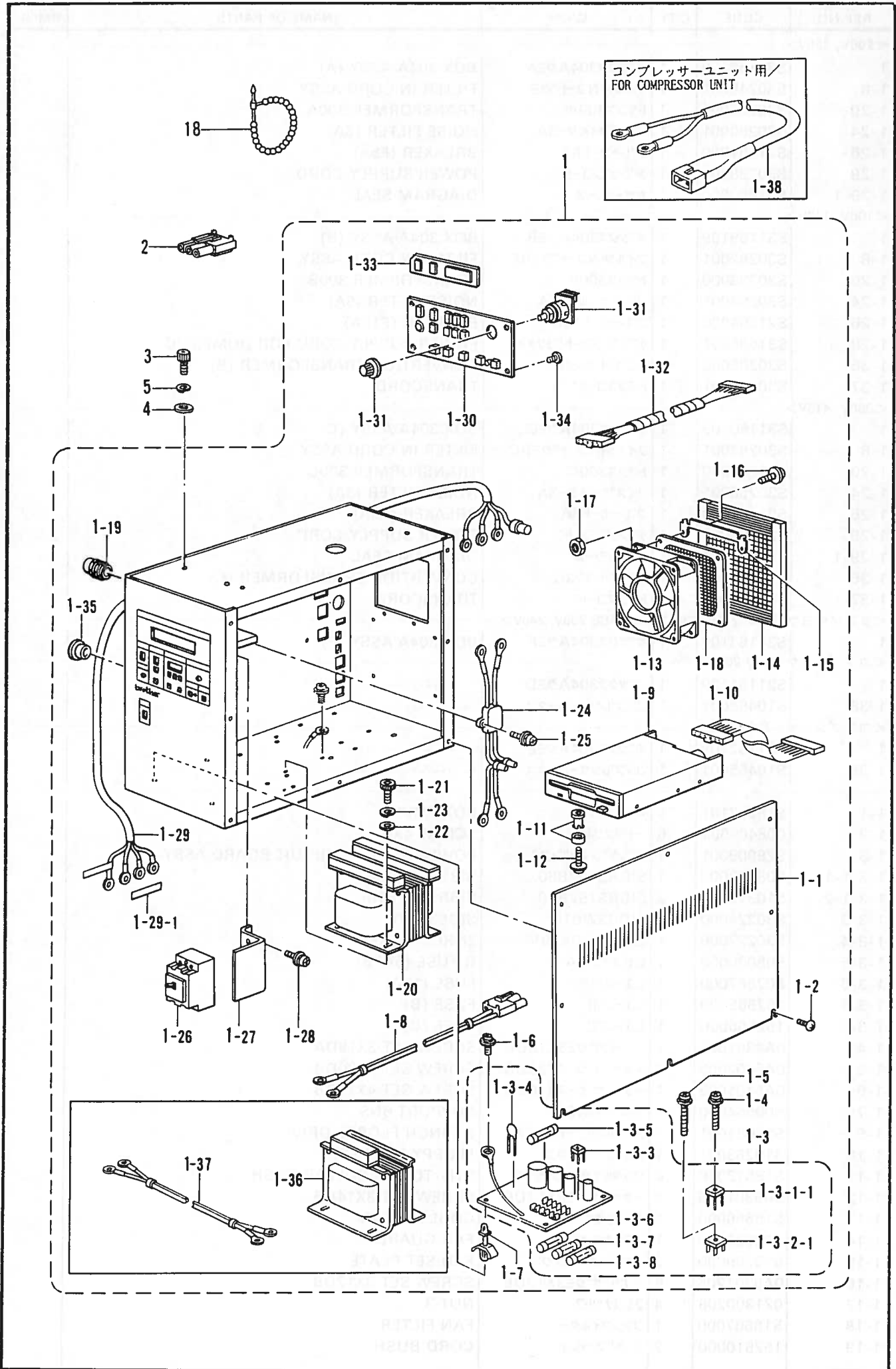

S. コントロールボックス関係 / Control box mechanism / Stromversorgung /
 Mécanisme du boîtier de contrôle / Mecanismo del caja de controles

REF.NO.	CODE	Q'TY	ヒンメイ	NAME OF PARTS	RMKS
1-21	018061036	4	アナボルト6X10	BOLT 6X10	
1-22	025060236	4	ヒラサ"カ"ネチユウ6	PLAIN WASHER 6	
1-23	028060246	4	ハ"ネサ"カ"ネ2-6	SPRING WASHER 2-6	
1-25	0A5301005	2	+ナヘ"サ"クミ3X10DB	SCREW SET 3X10DB	
1-27	S30251001	1	ブ"レ-カトリツケイタ	BREAKER SET PLATE	
1-28	0A5400805	2	+ナヘ"サ"クミ4X8DB	SCREW SET 4X8DB	
1-30	S16578101	1	キハ"ンB439054クミ	CIRCUIT BOARD (B439054) ASSY	
1-31	S10401001	1	スピ"ート"ホ"リウムクミ	SPEED VOLUME ASSY	
1-32	S10402001	1	パ"ネルハーネスA	PANEL HARNESS (A)	
1-33	S16580000	1	LEDカバー	LED COVER	
1-34	0A5400805	4	+ナヘ"サ"クミ4X8DB	SCREW SET 4X8DB	
1-35	S23337009	1	メクラセン	OIL CAP	
2	S16568000	1	コネクタ3191-03R1	CONNECTOR (3191-03R1)	
3	018083022	4	アナボルト8X30	BOLT 8X30	
4	025080232	4	ヒラサ"カ"ネチユウ8	PLAIN WASHER 8	
5	028080242	4	ハ"ネサ"カ"ネ2-8	SPRING WASHER 2-8	
18	340400001	5	ユニタイバンド	BEAD BAND	

T. 空圧関係 / Air pressure mechanism / Luftdruck /
 Mécanisme de la pression d'air / Mecanismo de la presión de aire

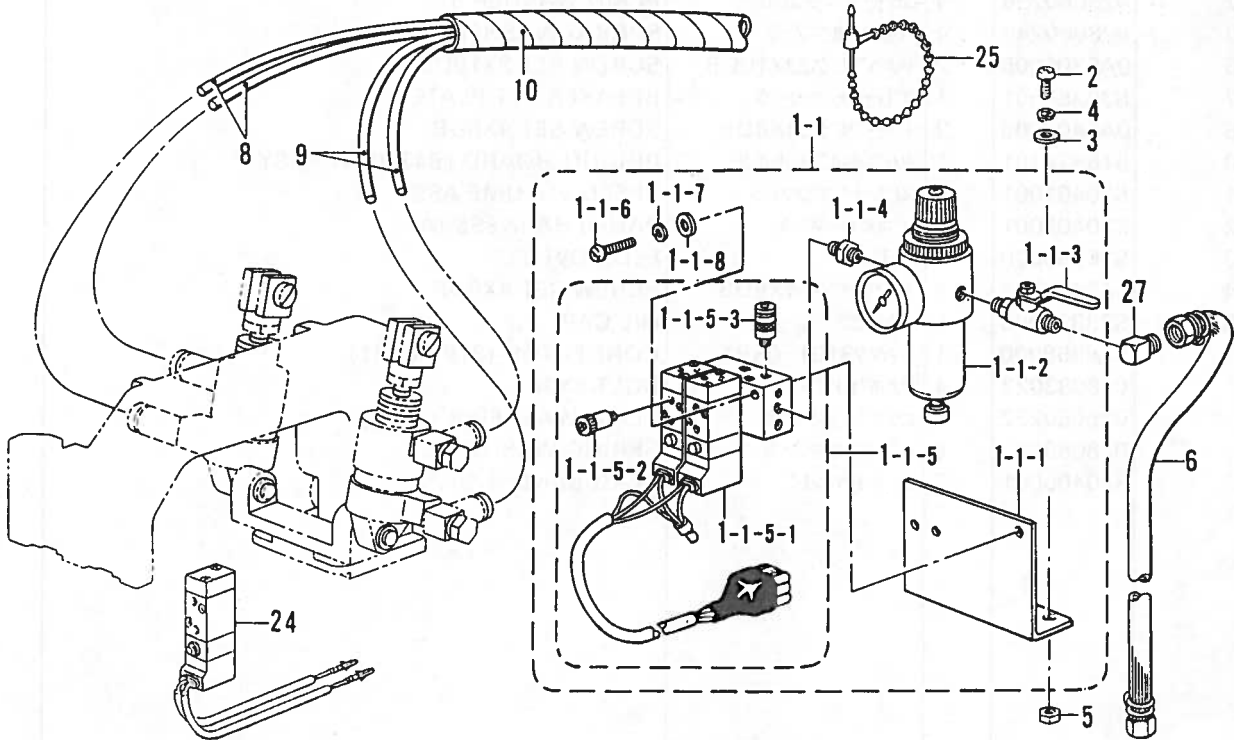

コンプレッサーユニット用
 / FOR COMPRESSOR UNIT

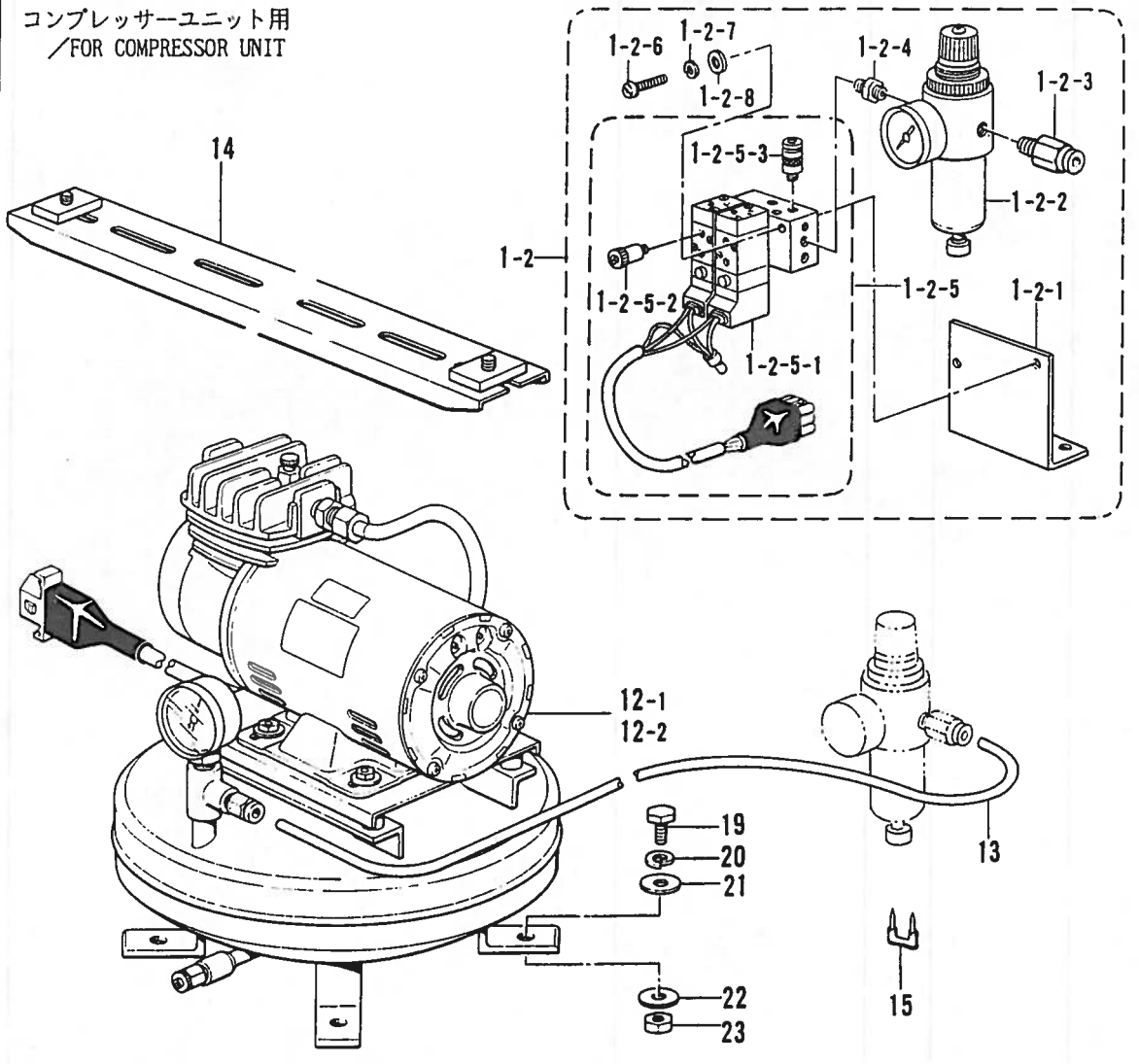

T. 空圧関係 / Air pressure mechanism / Luftdruck /
 Mécanisme de la pression d'air / Mecanismo de la presión de aire

REF.NO.	CODE	Q'TY	ヒンメイ	NAME OF PARTS	RMKS
1-1	S30616009	1	デ"ンシ"ハ"ルフ"2Aクミ	AIR VALVE (2A) ASSY	
1-1-1	S31551009	1	ハ"ルフ"トリツケイタ2-3	VALVE SET PLATE 2-3	
1-1-2	S09318101	1	インテグ"レータ	INTEGRATER	
1-1-3	S09231000	1	ホ"ールハ"ルフ"1/4	BALL VALVE 1/4	
1-1-4	S09228000	1	イケイニツプル	NIPPLE	
1-1-5	S30617001	1	デ"ンシ"ハ"ルフ"2クミ	AIR VALVE (2) ASSY	
1-1-5-1	S03789001	1	エアマニホルト"クミ	AIR MANIFOLD ASSY	
1-1-5-2	S03792001	4	ハイキシホ"リヘ"ン	EXHAUST THROTTLE VALVE	
1-1-5-3	S18415001	4	ハーフユニオンQ4M5	HALF UNION	
1-1-6	062302506	2	ナヘ"コ3X25	SCREW 3X25	
1-1-7	028030242	2	ハ"ネサ"カ"ネ2-3	SPRING WASHER 2-3	
1-1-8	025030232	2	ヒラサ"カ"ネチユウ3	PLAIN WASHER 3	
2	062501202	2	ナヘ"コM5X12	SCREW M5X12	
3	025050232	2	ヒラサ"カ"ネチユウ5	PLAIN WASHER 5	
4	028050242	2	ハ"ネサ"カ"ネ2-5	SPRING WASHER 2-5	
5	021500103	2	ナツト1シユ5	NUT 5	
6	149796001	1	ゴ"ムホ-スカナク"ツキ	AIR TUBE WITH CONNECTOR	
8	S10386100	2	ナイロンチューブ"R	NYLON TUBE (R)	
9	S10387100	2	ナイロンチューブ"L	NYLON TUBE (L)	
10	S15078000	2	スパイラルチューブ"	SPILAL TUBE	
25	340400001	1	ユニタイハ"ント"	BEAD BAND	
27	S32334000	1	PTチ-ーズ"1/4	PT CHEESE 1/4	
<コンプレッサーヨウ>					
1-2	S30618009	1	デ"ンシ"ハ"ルフ"2Bクミ	-----	
1-2-1	S31551009	1	ハ"ルフ"トリツケイタ2-3	-----	
1-2-2	S09318101	1	インテグ"レータ	-----	
1-2-3	S29710000	1	コネクタ-6-1/4	-----	
1-2-4	S09228000	1	イケイニツプル	-----	
1-2-5	S30617001	1	デ"ンシ"ハ"ルフ"2クミ	-----	
1-2-5-1	S03789001	1	エアマニホルト"クミ	-----	
1-2-5-2	S03792001	4	ハイキシホ"リヘ"ン	-----	
1-2-5-3	S18415001	4	ハーフユニオンQ4M5	-----	
1-2-6	062302506	2	ナヘ"コ3X25	-----	
1-2-7	028030242	2	ハ"ネサ"カ"ネ2-3	-----	
1-2-8	025030232	2	ヒラサ"カ"ネチユウ3	-----	
<100V>					
12-1	S05670002	1	コンプレツサユニット	-----	
<200V>					
12-2	S09393002	1	コンプレツサユニット	-----	
13	S32129000	1	ナイロンチューブ"	-----	
14	S10463102	1	フミイタササイ"イ	-----	
15	200190001	3	ステップル	-----	
19	017082203	4	ホ"ルト8X22	-----	
20	028080242	4	ハ"ネサ"カ"ネ2-8	-----	
21	025080232	4	ヒラサ"カ"ネチユウ8	-----	
22	025080336	4	ヒラサ"カ"ネタ"イ8	-----	
23	021080106	4	ナツト1シユ8	-----	
<ホキユウヨウ /FOR SUPPLY>					
24	S30609001	1	デ"ンシ"ハ"ルフ"1クミ	AIR VALVE (1) ASSY	

U. 動力台関係 / Power Table / Motorgestell /
 Mécanisme du plateau de la machine / Mecanismo del mesa de trabajo la máquina

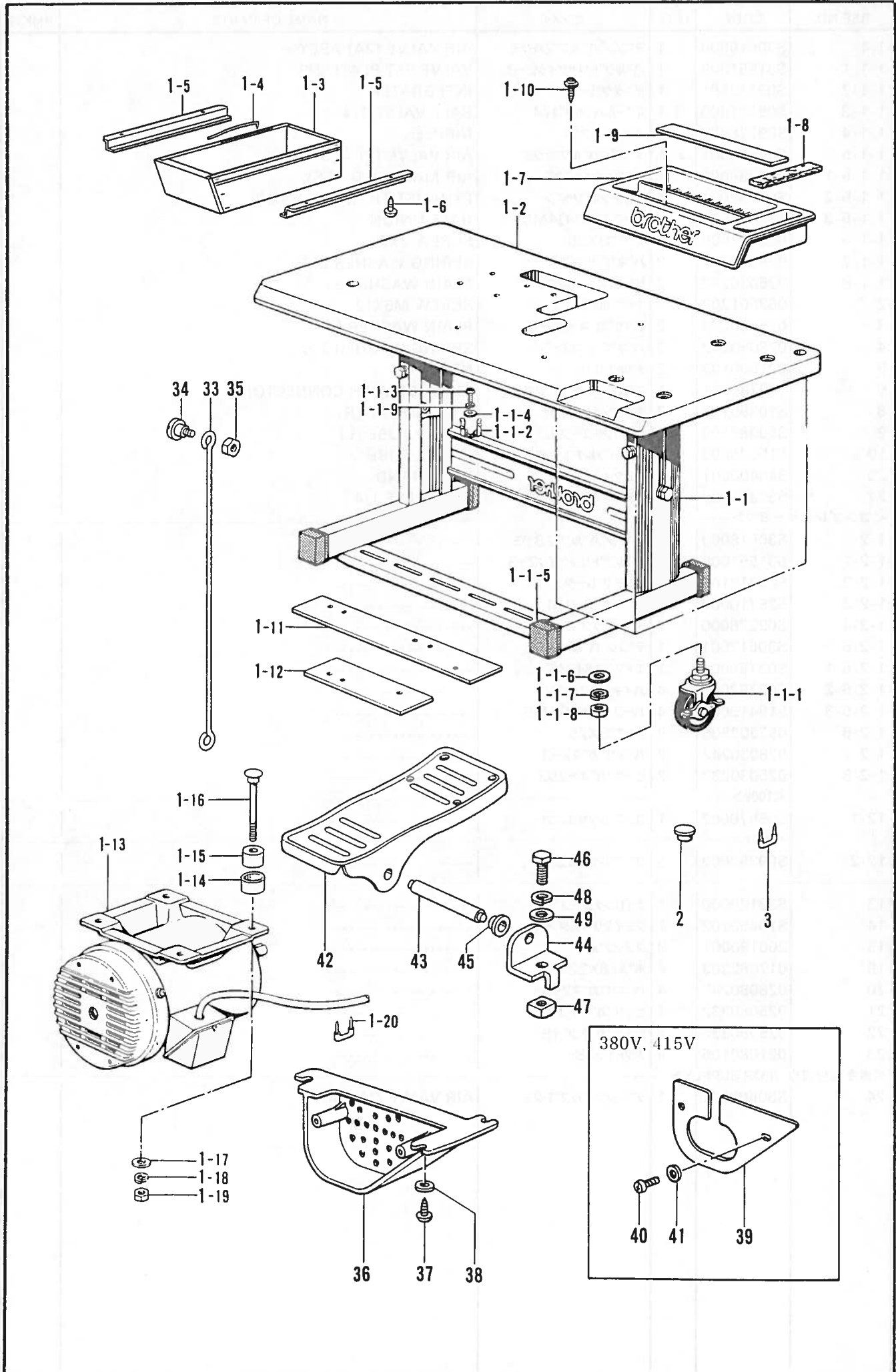

U. 動力台関係 / Power Table / Motorgestell /
Mécánisme du plateau de la machine / Mecanismo del mesa de trabajo la máquina

REF. NO	CODE	Q'TY	ヒンメイ	NAME OF PARTS	RMKS
1	S31660009	1	テーブルキヤクミ304AL	TABLE STAND ASSY (304AL)	
1-1	S10355109	1	タチスワリケンヨウキヤクミ	COMPATIBLE STAND ASSY	
1-1-1	S05223001	4	キャスター	CASTER	
1-1-2	133172003	1	アブラサシタ"イ	OIL BRACKET	
1-1-3	037521016	1	+ナヘ"タツヒ"ン 2シユ5	SCREW 5	
1-1-4	025050236	1	ヒラサ"ガ"ネチユウ-5	PLAIN WASHER 5	
1-1-5	S10661009	4	ソトアシワタゴム	RUBBER	
1-1-6	026120236	4	ヒラサ"ガ"ネミカ"キ12	PLAIN WASHER 12	
1-1-7	028120246	4	ハ"ネサ"ガ"ネ2-12	SPRING WASHER 2-12	
1-1-8	021120304	4	ナツト3シユ12	NUT 12	
1-1-9	028050246	1	ハ"ネサ"ガ"ネ2-5	SPRING WASHER 2-5	
1-2	S18864109	1	テーブル	TABLE	
1-3	119702004	1	ヨコヒキダ"シ	SIDE DRAWER	
1-4	101073001	1	ヒキダ"シコテイハ"ネ	SPRING	
1-5	101121003	2	ヨコヒキダ"シササエ	SIDE DRAWER SUPPORT	
1-6	032361306	4	+マルモクネシ"3.5X13	SCREW 3.5X13	
1-7	S15158009	1	コモノケース	ACCESSORY CASE	
1-8	S02740000	1	フェルト	FELT	
1-9	S02739000	1	ゴムシ"シヤクテープ"	RUBBER MAGNET TAPE	
1-10	S10476001	2	ハ"ンフツシヤタツヒ"ンネシ"	SCREW	
1-11	S10357100	1	アースイタA	EARTH PLATE (A)	
1-12	S10358100	1	アースイタB	EARTH PLATE (B)	
1-13	S10405000	1	ゼ"ンヘイ3ソウモータ	TOTALLY ENCLOSED MOTOR 3-PHASE	
1-14	146256001	4	クツシヨ"ンカナク"	CUSHION COLLAR	
1-15	146255000	4	クツシヨ"ン	CUSHION	
1-16	133740006	4	カクネボ"ルト6X70	BOLT 6X70	
1-17	025060336	4	ヒラサ"ガ"ネタ"イ6	PLAIN WASHER 6	
1-18	028060246	4	ハ"ネサ"ガ"ネ2-6	SPRING WASHER 2-6	
1-19	021060106	4	ナツト1シユ6	NUT 6	
1-20	200190001	3	ステツフル	STAPLE	
2	159150009	4	カマジ"クメクラセン	OIL CAP	
3	200190001	4	ステツフル	STAPLE	
36	S18633109	1	モーターカハ"ー	MOTOR COVER	
37	032422003	3	+マルモクネシ"4.1X20	SCREW 4.1X20	
38	116662003	3	サ"ガ"ネ	WASHER	
<380V, 415V>					
39	S20137001	1	モーターウシロカハ"ー	MOTOR BACK COVER	
40	138444001	2	ナヘ"Bタイト4X14	SCREW	
41	025040232	2	ヒラサ"ガ"ネチユウ4	PLAIN WASHER 4	
<デンジヨウ / SOLENOID TYPE>					
33	S02337001	1	オサエアケ"レンカン	WORK CLAMP LIFTER CONNECTING ROD	
34	115559002	1	ダ"ンネシ"4.76	STUD SCREW 4.76	
35	110161006	1	ナツト4.76	NUT 4.76	
42	S01199003	1	オサエアケ"フミイタ	TREADLE	
43	133188001	1	オサエアケ"フミイタシ"ク	TREADLE SHAFT	
44	119707003	2	フミイタシ"クウケ	TREADLE SHAFT BRACKET	
45	119708001	2	フミイタシ"クウケカラ"ー	TREADLE SHAFT BRACKET COLLAR	
46	017082206	2	ボ"ルト8X22	BOLT 8X22	
47	116694001	2	4カクナツト8	NUT 8	
48	028080240	2	ハ"ネサ"ガ"ネ2-8	SPRING WASHER 2-8	
49	025080236	2	ヒラサ"ガ"ネチユウ8	PLAIN WASHER 8	

V. 踏板關係 / Foot switch pedal mechanism / Fußbetätigung /
 Mécanisme de la pédale / Mecanismo de la pedal

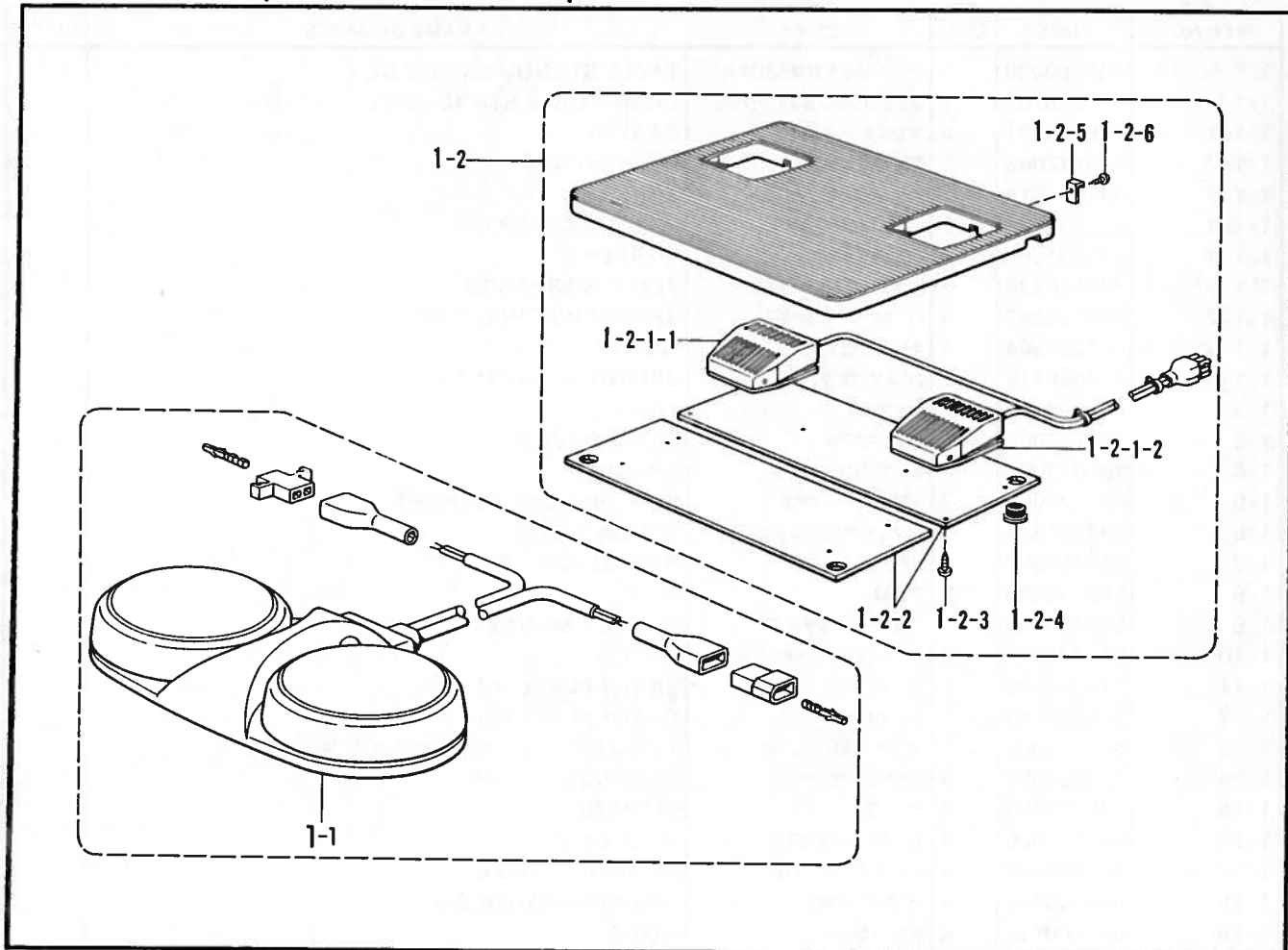

W. 付属装置関係 / Programmer device / Programmvorrichtung /
 Dispositif du programmeur / Programadora

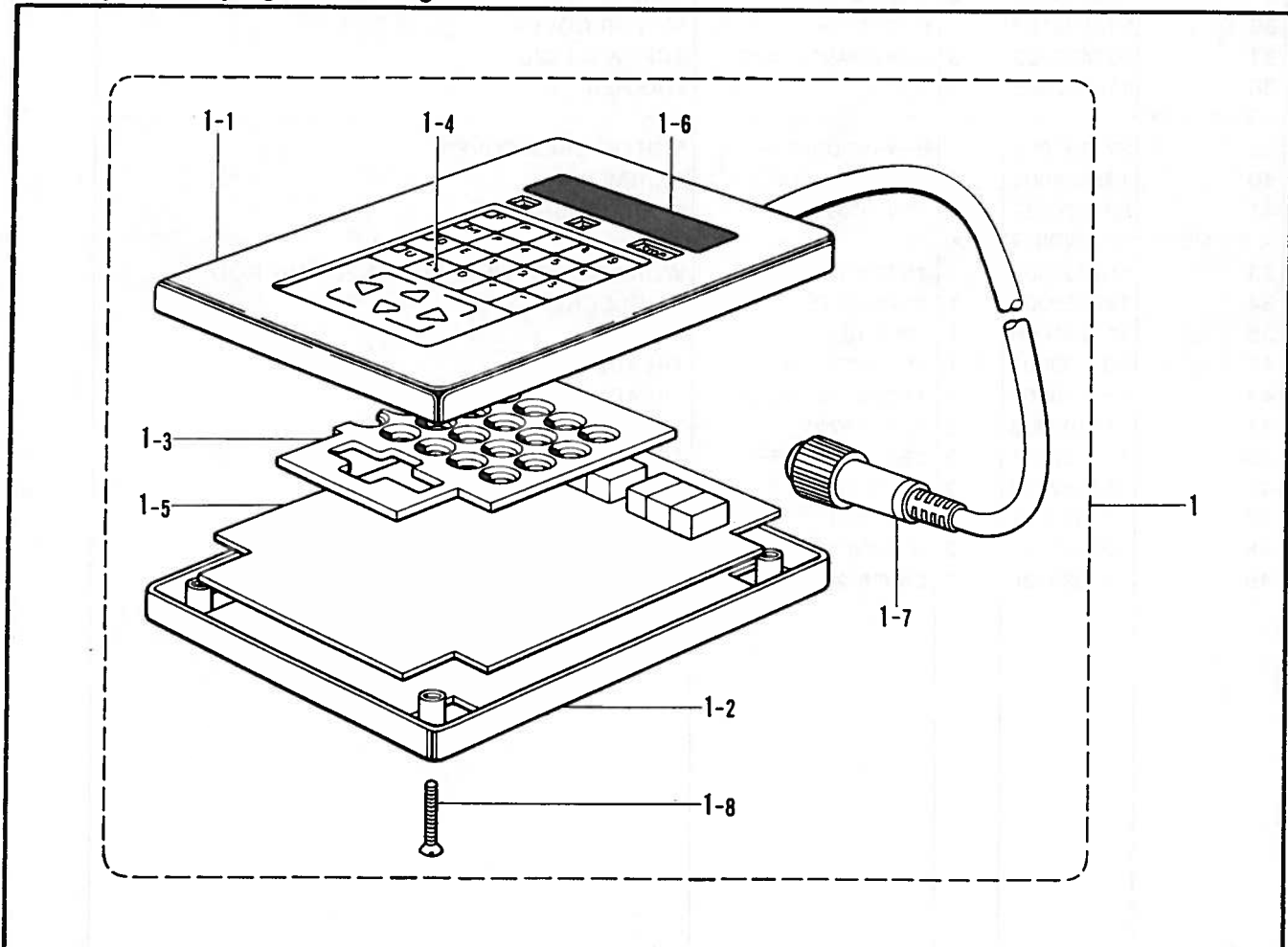

V. 踏板関係 / Foot switch pedal mechanism / Fußbetätigung /
 Mécanisme de la pédale / Mecanismo de la pedal

REF.NO.	CODE	Q'TY	ヒンメイ	NAME OF PARTS	RMKS
<デンジヨウ / SOLENOID TYPE>					
1-1	S32358001	1	マルカ"タフットスイッチクミ	ROTARY TYPE FOOT SWITCH ASSY	
<エア-ヨウ / AIR TYPE>					
1-2	S32342009	1	フットスイッチイタSクミ	FOOT SWITCH PLATE (S) ASSY	
1-2-1	S32343001	1	フットスイッチ2タ"ンクミ	FOOT SWITCH 2-STAGE ASSY	
1-2-1-1	S32344001	1	2タ"ンスイッチクミ	2-STAGE SWITCH ASSY	
1-2-1-2	S32345001	1	1タ"ンスイッチ	1-STAGE SWITCH	
1-2-2	S02977101	2	スイッチウケ	SWITCH SUPPORT PLATE	
1-2-3	034311302	10	+ サラモクネジ"3.1X13	SCREW 3.1X13	
1-2-4	159150009	4	カマシ"クメクラセン	OIL CAP	
1-2-5	S01825001	2	フミイタカケ	TREADLE HOOK	
1-2-6	031312006	2	マルモクネジ"3.1X20	SCREW 3.1X20	

W. 付属装置関係 / Programmer device / Programmvorrichtung /
 Dispositif du programmeur / Programadora

REF.NO.	CODE	Q'TY	ヒンメイ	NAME OF PARTS	RMKS
1	S02939009	1	プログラマ-クミ	PROGRAMMER ASSY	
1-1	S02940001	1	プログラマハコウエ	PROGRAMMER COVER (U)	
1-2	S02941001	1	プログラマハコシタ	PROGRAMMER COVER (D)	
1-3	S02942001	1	スペ-サー	SPACER	
1-4	S02943009	1	キーボードシート	KEY BOARD SHEET	
1-5	S02947001	1	プログラマキハ"ンBクミ	PROGRAMMER CIRCUIT BOARD ASSY (B)	
1-6	S02949001	1	スクリーンパネル	SCREEN PANEL	
1-7	S02950001	1	プログラマハーネスA	PROGRAMMER HARNESS (A)	
1-8	061302506	4	サラコ3X25	SCREW 3X25	

Z. 付属品関係/Accessories/Zubehör/
Accessoires/Accessorios

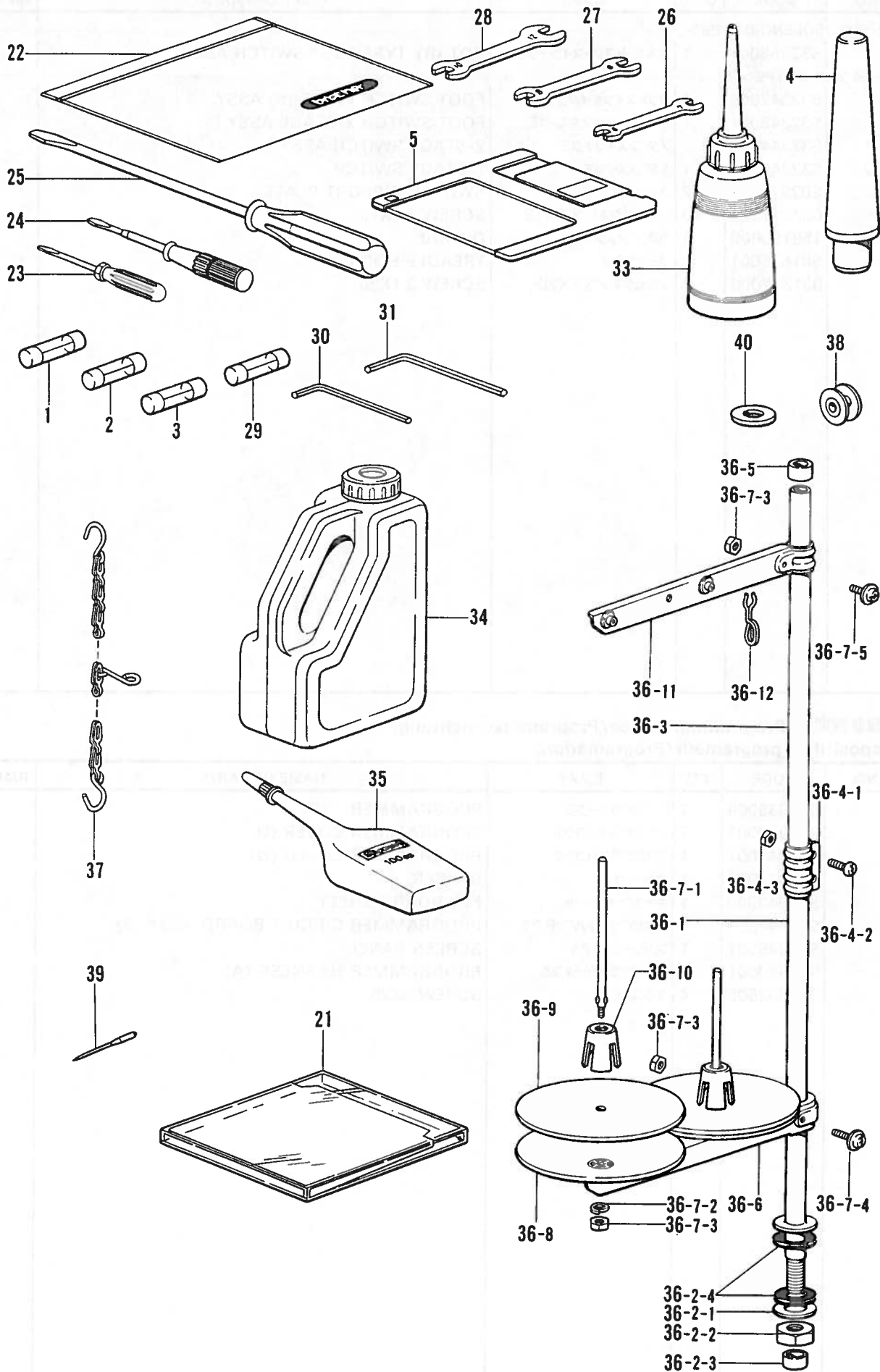

◎ 付属品の明細は変更することがあります。
 ◎ The details of included accessories are subject to change.
 ◎ Änderungen in der Aufstellung der Mitgelieferten Zubehöre sind vorbehalten.

◎ Les détails des accessoires inclus sont sujets à des changements.
 ◎ Los detalles de los accesorios incluidos pueden variar.

Z. 付属品関係 / Accessories / Zubehör /
Accessoires / Accesorios

REF.NO.	CODE	Q'TY	ヒンメイ	NAME OF PARTS	RMKS
1	S08030000	1	Gヒューズ"5AFB	G FUSE (5AFB)	
2	S02887000	1	ヒューズ"15A	FUSE (15A)	
3	152565000	1	ヒューズ"B	FUSE (B)	
4	S10359002	1	トウフ"マクラ	HEAD REST	
5	U42775001	1	3.5メデ"イア 2DD	3.5-MEDIA 2DD	
21	S09989000	1	フロッピ"ケース	FLOPPY CASE	
22	122991001	1	フゾクヒンホ"リフクロ	ACCESSORY BAG	
23	142443001	1	ネジ"マワシ1.9X52	SCREW DRIVER 1.9X52	
24	118837001	1	ネジ"マワシ3.4X70	SCREW DRIVER 3.4X70	
25	101572101	1	ネジ"マワシ5.5X190	SCREW DRIVER 5.5X190	
26	107779001	1	スパナ"6X7	SPANNER 6X7	
27	100887001	1	スパナ"8X9	SPANNER 8X9	
28	107780001	1	スパナ"10X12	SPANNER 10X12	
29	152566000	1	ヒューズ"C	FUSE (C)	
30	142721001	1	6カクホ"ウスハナ3	HEXAGONAL WRENCH 3	
31	118064001	1	6カクホ"ウスハナ4	HEXAGONAL WRENCH 4	
33	114483002	1	ホ"リオイルークミ	OILER ASSY	
34	154702001	1	オイルタンク	OIL TANK	
36	S02763202	1	イトタテタ"イクミ2DR	COTTON STAND ASSY 2DR	
36-1	156112003	1	コラムハ"イフD	COLUMN PIPE (D)	
36-2	S02777001	1	ハ"イフDネジ"セットB	PIPE (D) SCREW SET (B)	
36-2-1	150206002	1	ヒラサ"カ"ネ16	PLAIN WASHER 16	
36-2-2	150191002	1	6カクナツ"5/8	NUT 5/8	
36-2-3	150174000	1	コラムキャツ"フ	COLUMN CAP	
36-2-4	S01005000	2	イトタテゴ"ム	RUBBER WASHER	
36-3	150172003	1	コラムハ"イフ	COLUMN PIPE	
36-4	150106003	1	コラムシ"ョイントクミ	COLUMN JOINT ASSY	
36-4-1	150173003	1	コラムシ"ョイント	COLUMN JOINT	
36-4-2	062501406	2	ナヘ"コ5X14	SCREW 5X14	
36-4-3	021500106	2	1シユナツ"5	NUT 5	
36-5	150174000	1	コラムキャツ"フ	COLUMN CAP	
36-6	S02778002	1	スプ"ールホルダ"ー2	SPOOL HOLDER 2	
36-7	S02780001	1	スプ"ールネジ"セット2	SPOOL SCREW SET 2	
36-7-1	150179002	2	スプ"ールシ"クB	SPOOL SHAFT (B)	
36-7-2	028050246	2	ハ"ネサ"カ"ネ2-5	SPRING WASHER 2-5	
36-7-3	021500106	4	1シユナツ"5	NUT 5	
36-7-4	050503006	1	ナヘ"コヒラサ"5X30	WASHER SCREW 5X30	
36-7-5	050501406	1	ナヘ"コヒラサ"5X14	WASHER SCREW 5X14	
36-8	150180002	2	ウケサ"ラ	SPOOL STAND BASE	
36-9	150182000	2	スプ"ールマット	SPOOL MAT	
36-10	126863001	2	スプ"ールクツシヨ"ン	SPOOL CUSHION	
36-11	S02786002	1	スレツト"ハンガ"ークミ2	THREAD HANGER ASSY 2	
36-12	S02747101	1	イトカケハ"ネ	SPRING	
37	S10472001	1	クサリク"ミ	CHAIN ASSY	
38	S15665001	3	ホ"ビ"ンLA	BOBBIN (LA)	
40	S10208001	1	イト"ウハカンサ" T=0.4	WASHER T=0.4	
40	S10208002	1	イト"ウハカンサ" T=0.5	WASHER T=0.5	
40	S10208003	1	イト"ウハカンサ" T=0.6	WASHER T=0.6	
<チュウアツモノヨウ /FOR MEDIUM THICK MATERIALS>					
35	S06706001	1	シリコンオイル	SILICONE OIL	
39	107415016	1	ミシンハリDPX5(#16)	NEEDLE DPX5 (#16)	
<アツモノヨウ /FOR THICK MATERIALS>					
39	145646021	1	ミシンハリDPX17(#21)	NEEDLE DPX17 (#21)	







オプションパーツ / Optional parts / Sonderzubehör /
 Pieces en option / Piezas opción



オサエアシ / Presser Foot

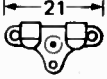
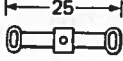

A	152283-001	B	152636-001	C	152637-001	D	154069-001
E	154089-001	F	157237-001	G	158592-001	J	S13815-001

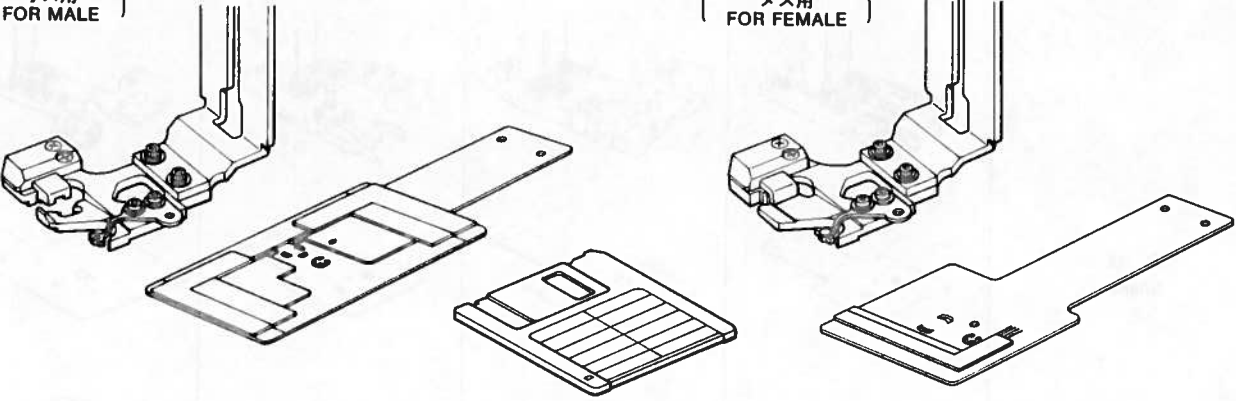
ハリアナイタ / Needle Hole Plate

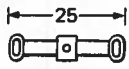
A	S10211-001	E	S10212-001	F	S10213-001
D	S29997-001	H	S30450-001	L	S25127-001
ED	S30925-001	FD	S30926-001		

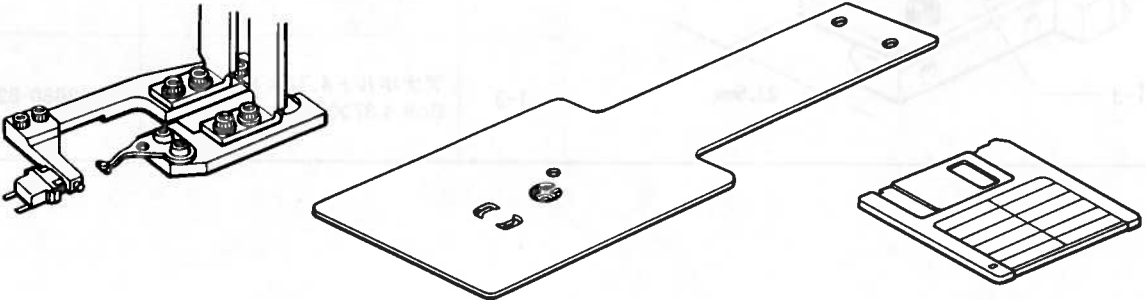

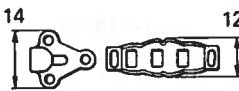
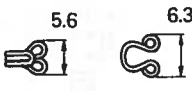

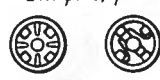
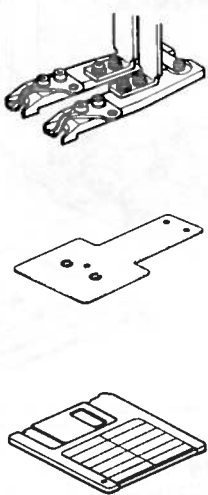
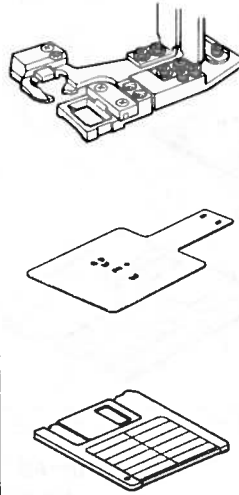
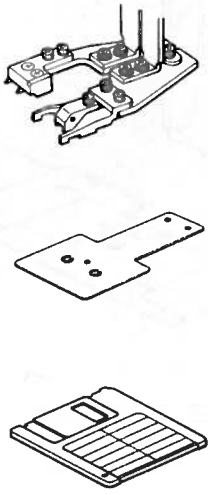
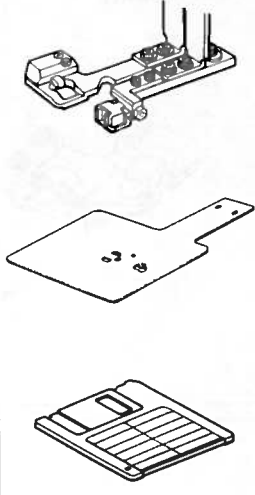

品名 Name of Parts	310-HS ソウチソウクミ 310-HS Device Unit			
	M-508 (オス MALE)	M-508 (メス FEMALE)	M-525 (オス MALE)	M-525 (メス FEMALE)
部品コード Parts Code	S18581-001	S18590-001	S18598-001	S18606-001
ホック寸法 Hook Size (mm)				
スナップ寸法 Snap size (mm)	OM $\phi 7.6$, $\phi 8.6$			
				
(オス用 FOR MALE)		(メス用 FOR FEMALE)		
				

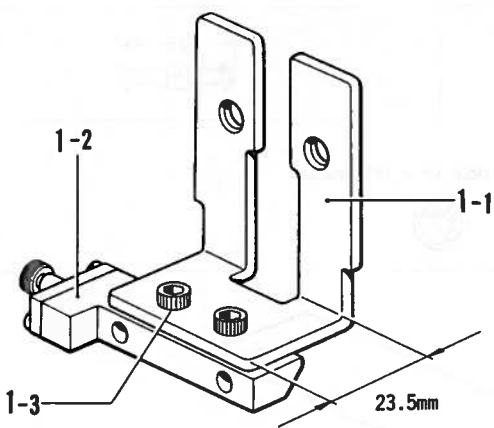
品名 Name of Parts	310-AS ソウチソウクミ 310-AS Device Unit	
	M-508	M-525
部品コード Parts Code	S18614-001	S18621-001
ホック寸法 Hook Size (mm)		
スナップ寸法 Snap size (mm)	OM $\phi 7.6$, $\phi 8.6$ (メス / FEMALE) 	
		

品名 Name of Parts	310-SW ソウチソウクミ 310-SW Device Unit	310-HE ソウチクミ 310-HE Device Unit		
	-	M-510	M-10	M-521
部品コード Parts Code	S21553-001	S21559-001	S21565-001	S21591-001
フック寸法 (mm) Hook Size	-			
スナップ寸法 (mm) Snap size	OM $\phi 7.6$, $\phi 8.6$ 	-	-	-
形状 Shape				

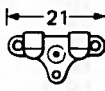
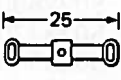
◎ワンタッチオサエヨウ /For One-touch Clamp

	1	ワンタッチオサエ UN クミ One-touch Presser foot (UN) ASSY	S24612-001
	1-1	OT オサエアシ UN OT Work clamp (UN)	S24613-001
	1-2	オサエホルダー L Presser holder (L)	S20282-001
	1-3	アナボルト 4.37×8 Bolt 4.37×8	018680-822

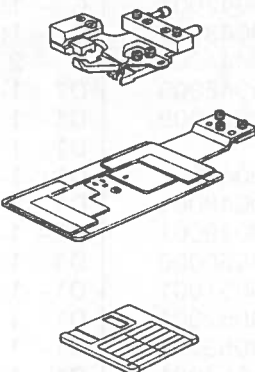
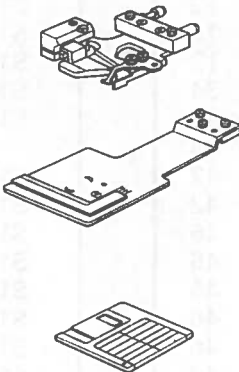
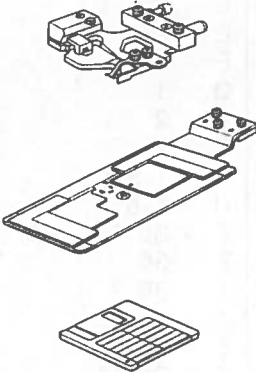
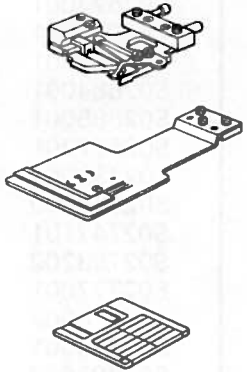
品名 Name of Parts	310-HSQ ソウチクミ 310-HSQ device assembly			
	M-508 (オス Male)	M-508 (メス Female)	M-525 (オス Male)	M-525 (メス Female)
部品コード Parts Code	S24605-001	S24614-001	S24621-001	S24628-001
ホック寸法 (mm) Hook Size				
スナップ寸法 (mm) Snap size	OM $\phi 7.6, \phi 8.6$			
				
形状 Shape				

OTオクリイタダイクミ
OT Feed Plate
Bracket Assembly
S14841-001



CODE	REF.NO.	PAGE
S00313009	F - 63	14
S00554000	S - 1-7	36
S00705001	M - 44	28
S00902001	F - 57	14
S01005000	Z - 36-2-4	46
S01199003	U - 42	42
S01825001	V - 1-2-5	44
S01998001	L - 1-12	26
S02269001	C - 25	6
S02337001	U - 33	42
S02354001	M - 18	28
S02429001	H - 18-1	20
S02438001	K - 31-1	24
S02439001	K - 31-2	24
S02445001	A - 56	2
S02538009	C - 12	6
S02664001	P - 12-2	32
S02665000	P - 12-3	32
S02667001	E - 3	12
S02668000	E - 4	12
S02672002	E - 21	12
S02677001	E - 23	12
S02678001	E - 25	12
S02680001	E - 11	12
S02684001	Q - 1	34
S02685001	Q - 2	34
S02687201	Q - 7	34
S02739000	U - 1-9	42
S02740000	U - 1-8	42
S02747101	Z - 36-12	46
S02763202	Z - 36	46
S02777001	Z - 36-2	46
S02778002	Z - 36-6	46
S02780001	Z - 36-7	46
S02786002	Z - 36-11	46
S02887000	S - 1-3-6	36
	Z - 2	46
S02917001	P - 31	32
S02939009	W - 1	44
S02940001	W - 1-1	44
S02941001	W - 1-2	44
S02942001	W - 1-3	44
S02943009	W - 1-4	44
S02947001	W - 1-5	44
S02949001	W - 1-6	44
S02950001	W - 1-7	44
S02977101	V - 1-2-2	44
S03327000	Q - 6	34
S03662000	J - 15-1	22
S03677001	E - 16	12
	F - 70	16
S03704001	H - 16	20
S03789001	T - 1-1-5-1	40
	T - 1-2-5-1	40
S03792001	T - 1-1-5-2	40
	T - 1-2-5-2	40
S03800001	D1- 1-2-17	8
S03801001	D1- 1-2-19	8
S03820000	D1- 1-2-23	8
S03899000	D1- 1-1-27	8
	D1- 1-2-21	8
	D2- 27	10
S05223001	U - 1-1-1	42
S05670002	T - 12-1	40
S06706001	Z - 35	46
S07885000	Q - 13	34
S08030000	S - 1-3-5	36

CODE	REF.NO.	PAGE
S08030000	Z - 1	46
S08032000	S - 1-3-1-1	36
S09228000	T - 1-1-4	40
	T - 1-2-4	40
S09231000	T - 1-1-3	40
S09318101	T - 1-1-2	40
	T - 1-2-2	40
S09393002	T - 12-2	40
S09989000	Z - 21	46
S10025001	A - 51	2
S10026001	A - 6	2
S10027002	A - 10	2
S10028000	A - 11	2
S10029109	A - 16	2
S10030002	A - 18	2
S10035001	C - 1	6
S10036001	C - 2	6
S10038001	C - 3	6
S10039001	C - 8	6
S10040001	C - 14	6
S10041001	C - 19	6
S10042001	C - 19-5	6
S10043001	C - 19-6	6
S10044001	C - 27	6
S10045009	D1- 1-1	8
S10046009	D1- 1-1-1	8
	D1- 1-2-1	8
S10047001	D1- 1-1-2	8
S10048001	D1- 1-1-3	8
S10049001	D1- 1-1-5	8
S10050000	D1- 1-1-6	8
S10051001	D1- 1-1-7	8
S10052001	D1- 1-1-8	8
S10053001	D1- 1-1-9	8
S10054001	D1- 1-1-11	8
	D1- 1-2-2	8
S10055001	D1- 1-1-12	8
S10056001	D1- 1-1-13	8
	D1- 1-2-4	8
S10057001	D1- 1-1-14	8
S10058001	D1- 1-1-15	8
	D1- 1-2-6	8
S10059001	D1- 1-1-25	8
S10060101	D1- 1-1-26	8
S10063001	D3- 73	12
S10065001	D3- 10	12
S10066001	D2- 12	10
S10077100	D2- 31	10
S10078001	D2- 32	10
	G - 28	18
S10079001	D2- 33	10
	G - 29	18
S10080001	D2- 35	10
S10081001	D2- 36	10
	G - 5	18
S10082001	D2- 38	10
	G - 8	18
S10083001	D2- 40	10
S10085000	D2- 47	10
S10086001	D2- 49	10
S10087101	D2- 50	10
	G - 19	18
S10088001	D2- 55	10
S10089001	D2- 57	10
S10090001	A - 45	2
S10091001	D2- 70	10
S10092001	F - 1	14

CODE	REF.NO.	PAGE
S10093001	F - 3	14
S10095001	F - 6	14
S10097001	F - 8	14
S10098001	F - 10	14
S10101001	F - 14	14
S10102001	F - 16-1	14
S10103001	F - 16-2	14
S10105001	F - 21	14
S10106001	F - 23	14
S10107001	F - 24	14
S10108001	F - 26	14
S10109001	F - 29	14
S10110001	F - 31	14
S10111001	F - 39	14
S10112001	F - 40	14
S10113001	F - 42	14
S10114001	F - 46	14
S10115001	F - 48	14
S10119001	F - 51	14
S10121001	F - 55-1	14
S10122001	F - 55-2	16
S10123001	F - 56	14
S10125009	F - 62	14
S10126001	G - 1	18
S10131000	G - 7	18
S10132001	G - 10	18
S10133000	G - 17	18
S10134001	G - 18	18
S10137001	G - 36	18
S10140009	G - 44	18
S10141009	A - 47	2
S10142100	A - 48	2
S10145001	H - 4	20
S10147101	H - 11	20
S10149101	H - 12	20
S10151100	J - 2-2	22
S10153000	J - 2-4	22
S10155000	J - 5	22
S10156000	J - 6	22
S10157000	J - 7	22
S10160000	J - 8-3	22
S10161000	J - 8-4	22
S10162001	J - 10	22
S10163001	J - 13	22
S10164000	J - 14	22
S10166100	J - 15-2	22
S10167000	J - 20	22
S10168000	J - 21	22
S10169000	A - 62	2
S10171002	L - 1-1	26
S10172001	L - 1-2	26
S10173001	L - 1-11	26
S10174000	L - 1-21	26
S10175001	L - 1-23	26
S10178001	M - 3	28
S10179001	M - 5	28
S10182101	M - 7	28
S10189001	M - 16	28
S10190001	M - 20	28
S10191001	M - 22-1	28
S10192001	M - 23	28
	M - 33	28
S10193001	M - 24	28
S10194001	M - 25	28
S10195001	M - 26	28
S10196101	M - 30	28
S10197001	M - 32	28

CODE	REF.NO.	PAGE
S10198001	M - 36	28
S10202001	M - 37	28
S10203001	M - 39	28
S10204101	M - 40	28
S10205001	M - 42	28
S10208001	M - 43	28
	Z - 40	46
S10208002	M - 43	28
	Z - 40	46
S10208003	M - 43	28
	Z - 40	46
S10209101	M - 45	28
S10210101	M - 46	28
S10213001	M - 50	28
S10214009	E - 5	12
S10215009	E - 8	12
S10216009	E - 12	12
S10217001	E - 13	12
S10219001	N - 1	30
S10220101	N - 7	30
S10221001	N - 7-1	30
S10222001	N - 7-2	30
S10224001	N - 7-5	30
S10225001	N - 7-6	30
S10228001	N - 7-7	30
S10229101	N - 7-8	30
S10230000	N - 10	30
S10231001	N - 12	30
S10232001	N - 16	30
S10233101	N - 18	30
S10236001	N - 19	30
S10237001	N - 7-10	30
S10238001	N - 24	30
S10239001	N - 28	30
S10240009	P - 1	32
S10241001	P - 2	32
S10242000	P - 6	32
S10243000	P - 36	32
	P - 9	32
S10244000	P - 19	32
S10245001	P - 29	32
S10246000	P - 30	32
	P - 32	32
S10247001	P - 39	32
S10249001	P - 41	32
S10258000	A - 58	2
S10259000	A - 59	2
S10260002	A - 42	2
S10261009	B - 58	4
S10262009	B - 56	4
S10267001	M - 22	28
S10268001	L - 1-22	26
S10283001	S - 1-10	36
S10289000	S - 1-15	36
S10315000	S - 1-3-1-2	36
S10336000	S - 1-14	36
S10352101	G - 54	18
S10353000	J - 22	22
S10355109	U - 1-1	42
S10357100	U - 1-11	42
S10358100	U - 1-12	42
S10359002	Z - 4	46
S10361001	F - 53	14
S10364001	J - 2-1	22
S10365001	P - 24	32
S10366001	P - 25	32
S10367009	P - 12	32

CODE	REF.NO.	PAGE
S10370001	P - 37	32
S10371001	F - 44	14
S10372100	F - 45	14
S10373101	H - 18	20
S10374000	J - 23	22
S10375109	D1- 1-2	8
S10377101	D1- 1-2-3	8
S10378101	D1- 1-2-5	8
S10379001	D1- 1-2-14	8
S10380101	D1- 1-2-15	8
S10383001	C - 10	6
S10386100	T - 8	40
S10387100	T - 9	40
S10401001	S - 1-31	38
S10402001	S - 1-32	38
S10405000	U - 1-13	42
S10406001	B - 52	4
S10438001	L - 1-15	26
S10463102	T - 14	40
S10465001	S - 1-38	36
S10468000	P - 43	32
S10469001	K - 19	24
S10470001	E - 17	12
S10471001	D2- 77	10
S10472001	Z - 37	46
S10473000	B - 57	4
S10474001	F - 19	14
S10476001	U - 1-10	42
S10478000	J - 2-3	22
S10661009	U - 1-1-5	42
S11182009	K - 14	24
S11314001	H - 5	20
S12441001	K - 33	24
S12587001	D3- 83	12
S13399001	F - 65	16
S13559000	J - 15	22
S15078000	T - 10	40
S15158009	U - 1-7	42
S15589000	E - 26	12
S15662001	H - 26	20
S15663001	H - 26	20
S15665001	H - 31	20
	Z - 38	46
S15667001	H - 28-3	20
	H - 30	20
S15695001	F - 66	16
S15902101	H - 28	20
S16074001	H - 28-1	20
S16492001	H - 28-2	20
S16566000	S - 1-13	36
S16567000	S - 1-18	36
S16568000	S - 2	38
S16578101	S - 1-30	38
S16580000	S - 1-33	38
S16661001	S - 1-9	36
S18415001	D1- 1-2-16	8
	T - 1-1-5-3	40
	T - 1-2-5-3	40
S18507101	S - 1-1	36
S18520100	L - 3	26
S18573000	S - 1-11	36
S18633109	U - 36	42
S18653001	M - 1	28
S18672001	A - 50	2
S18676001	D3- 7	12
S18677001	D3- 6	12
S18679001	D2- 18	10

CODE	REF.NO.	PAGE
S18680100	D2- 21	10
S18685001	G - 52-1	18
S18686001	G - 52-2	18
S18688001	G - 40	18
S18689001	G - 42	18
S18690100	G - 4	18
S18692001	G - 2	18
S18694009	B - 54	4
S18695001	A - 32	2
S18707149	B - 29	4
S18864109	U - 1-2	42
S18867000	G - 27	18
S18919001	M - 9	28
S19651001	G - 32	18
S19658000	A - 63	2
S19661001	F - 4	14
S19662001	F - 5	14
	F - 9	14
S19663001	F - 7	14
S19664001	F - 11	14
S20137001	U - 39	42
S21181000	S - 1-26	36
S21504000	S - 1-26	36
S21527001	J - 8-1	22
S21774001	H - 7	20
S21776001	D1- 1-1-16	8
	D1- 1-2-7	8
S23337009	S - 1-35	38
S27844001	D2- 41	10
	G - 11	18
S29007001	R - 1	34
S29008001	R - 2	34
S29009001	S - 1-3	36
S29124000	P - 2-1	32
S29710000	T - 1-2-3	40
S30026001	F - 13	14
S30033001	M - 12-3	28
S30114001	M - 12	28
S30115001	M - 12-1	28
S30206000	R - 2-1	34
S30224000	S - 1-3-3	36
S30227000	S - 1-3-4	36
S30232000	S - 1-20	36
S30233000	S - 1-20	36
S30234000	S - 1-20	36
S30238001	S - 1-29	36
S30249001	S - 1-8	36
S30250001	S - 1-24	36
S30251001	S - 1-27	38
S30253001	R - 6	34
S30254001	R - 7	34
S30264001	S - 1-24	36
S30281001	S - 1-37	36
S30282001	S - 1-8	36
S30284001	P - 40	32
S30285000	S - 1-36	36
S30286000	S - 1-36	36
S30609001	T - 24	40
S30616009	T - 1-1	40
S30617001	T - 1-1-5	40
	T - 1-2-5	40
S30618009	T - 1-2	40
S31012001	F - 37	14
S31013001	F - 38	14
S31158109	S - 1	36
S31159109	S - 1	36
S31160109	S - 1	36

CODE	REF.NO.	PAGE
S31161109	S - 1	36
S31162109	S - 1	36
S31163109	S - 1	36
S31551009	T - 1-1-1	40
	T - 1-2-1	40
S31567001	D2- 24	10
S31568000	D2- 29	10
S31585001	S - 1-29	36
S31650000	S - 1-29-1	36
S31660009	U - 1	42
S31663009	D2- 15	10
S31664001	D2- 16	10
S32129000	T - 13	40
S32334000	T - 27	40
S32342003	V - 1-2	44
S32343001	V - 1-2-1	44
S32344001	V - 1-2-1-1	44
S32345001	V - 1-2-1-2	44
S32358001	V - 1-1	44
T22706000	R - 1-3	34
U31357000	R - 1-1	34
U31359000	R - 1-2	34
U42775001	Z - 5	46
0A4301605	S - 1-4	36
0A5301005	S - 1-25	38
0A5301205	S - 1-16	36
0A5301405	S - 1-12	36
0A5400805	S - 1-28	38
	S - 1-34	38
0A5401005	S - 1-6	36
0A5402005	S - 1-5	36
008400604	S - 1-2	36
011679312	D1- 1-1-28	8
	D1- 1-2-22	8
013760612	K - 25	24
014400522	D2- 51	10
	G - 20	18
014401232	D1- 1-1-23	8
014680422	L - 1-14	26
	L - 1-20	26
014680622	D1- 1-1-16-1	8
	D1- 1-2-7-1	8
	D2- 17	10
	D2- 28	10
	H - 3	20
	M - 38	28
	N - 13	30
014760622	C - 13	6
	C - 20	6
	C - 4	6
	C - 9	6
	D1- 1-1-20	8
	D1- 1-2-11	8
	D2- 37	10
	D2- 39	10
	D2- 56	10
	G - 6	18
	G - 9	18
	H - 13	20
	H - 19	20
	H - 6	20
	L - 4	26
	M - 10	28
	M - 29	28
	N - 22	30
014770622	C - 16	6
	C - 18	6

CODE	REF.NO.	PAGE
014770622	D2- 42	10
	G - 12	18
	H - 16-1	20
	M - 13	28
	M - 2	28
017067002	B - 3	4
017082203	T - 19	40
017082206	U - 46	42
018060822	N - 8	30
018061036	S - 1-21	38
018061222	F - 32	14
018061422	N - 2	30
018083022	S - 3	38
018400622	D1- 1-1-22	8
	D1- 1-2-13	8
018501022	D2- 25	10
018501222	D1- 2	8
	P - 26	32
018501422	H - 23	20
	N - 11	30
	P - 46	32
018501622	D2- 30	10
	G - 16	18
	G - 25	18
018502522	G - 26	18
018503022	A - 36	2
	D2- 62	10
018505022	D2- 61	10
018680822	D2- 20	10
	D2- 34	10
	G - 30	18
018681022	E - 6	12
021060102	B - 6	4
021060106	U - 1-19	42
021080106	T - 23	40
021120304	U - 1-1-8	42
021300206	S - 1-17	36
021400102	D1- 1-1-24	8
021500103	T - 5	40
021500106	Z - 36-4-3	46
	Z - 36-7-3	46
021680202	F - 58	14
	L - 1-28	26
	M - 35	28
021680212	N - 25	30
021710202	F - 52	14
025030232	T - 1-1-8	40
	T - 1-2-8	40
025040232	D1- 1-1-21	8
	D1- 1-2-12	8
	P - 5	32
	U - 41	42
025050232	A - 37	2
	D2- 26	10
	D2- 59	10
	G - 24	18
	P - 28	32
	T - 3	40
025050236	U - 1-1-4	42
025060132	D2- 14	10
025060232	F - 34	14
	N - 4	30
025060236	S - 1-22	38
025060332	B - 4	4
025060336	U - 1-17	42
025080232	S - 4	38
	T - 21	40

CODE	REF.NO.	PAGE
025080236	U - 49	42
025080336	T - 22	40
025350236	A - 57	2
025680132	A - 55	2
	M - 52	28
025680232	D2- 82	10
	D3- 8	12
	M - 34	28
026120236	U - 1-1-6	42
028030242	T - 1-1-7	40
	T - 1-2-7	40
028040242	P - 4	32
028050242	D2- 60	10
	P - 27	32
	T - 4	40
028050246	U - 1-1-9	42
	Z - 36-7-2	46
028060242	B - 32	4
	F - 33	14
	N - 3	30
028060246	S - 1-23	38
	U - 1-18	42
028080240	U - 48	42
028080242	S - 5	38
	T - 20	40
028120246	U - 1-1-7	42
031312006	V - 1-2-6	44
032361306	U - 1-6	42
032422003	U - 37	42
034311302	V - 1-2-3	44
037521016	U - 1-1-3	42
047201042	L - 1-26	26
047251640	J - 26	22
047501242	A - 38	2
048030342	D1- 1-1-4	8
	E - 15	12
	F - 61	16
	F - 67	16
048040342	D1- 1-1-10	8
	D1- 1-2-18	8
	E - 20	12
	F - 47	14
	N - 27	30
	N - 7-9	30
048050342	D1- 1-1-19	8
	D1- 1-2-10	8
	L - 1-16	26
	L - 1-9	26
048060342	D2- 44	10
	D2- 54	10
	G - 15	18
	G - 23	18
	M - 28	28
	N - 21	30
048070342	M - 11	28
048080342	H - 24	20
	H - 9	20
048160242	D2- 52	10
	G - 13	18
	G - 21	18
048200142	F - 18	14
050501406	Z - 36-7-5	46
050503006	Z - 36-7-4	46
060680512	E - 19	12
061302506	W - 1-8	44
062300612	P - 15	32
062302506	T - 1-1-6	40

CODE	REF.NO.	PAGE
062302506	T - 1-2-6	40
062401012	P - 3	32
062501202	T - 2	40
062501406	Z - 36-4-2	46
062630712	Q - 8	34
062660412	H - 18-2	20
062660712	H - 18-6	20
062670412	K - 28	24
062670512	A - 31	2
062670612	A - 61	2
	D2- 78	10
	J - 19	22
	J - 25	22
	J - 4	22
	K - 30	24
	K - 4	24
	L - 1-7	26
	N - 7-4	30
	P - 10	32
	P - 14	32
	P - 17	32
	Q - 12	34
062670812	A - 17	2
062671012	M - 6	28
062680512	D3- 11	12
	E - 22	12
	E - 9	12
062680612	B - 55	4
	J - 9	22
062680712	L - 1-25	26
062680812	A - 33	2
	C - 19-7	6
	D2- 58	10
	D2- 71	10
	G - 35	18
	G - 38	18
	J - 17	22
	P - 38	32
062681012	M - 4	28
062681212	F - 27	14
	F - 43	14
062681612	Q - 4	34
062710612	B - 53	4
	B - 8	4
062710712	K - 2	24
062710812	F - 2	14
062711012	A - 15	2
	L - 6	26
	Q - 10	34
062711212	A - 34	2
	A - 35	2
	D2- 63	10
	L - 2	26
062711412	A - 14	2
062760812	N - 17	30
062761412	D2- 13	10
062771012	N - 9	30
070688850	D2- 43	10
081003670	H - 15	20
	H - 21	20
081006070	B - 10	4
100032004	F - 54	14
	M - 48	28
100136001	K - 21	24
	L - 1-29	26
100250001	C - 15	6
100360003	M - 51	28

CODE	REF.NO.	PAGE
100402004	K - 18	24
100645003	D2- 79	10
	E - 7	12
	G - 33	18
	G - 37	18
	N - 26	30
	Q - 3	34
100887001	Z - 27	46
101073001	U - 1-4	42
101121003	U - 1-5	42
101482001	C - 5	6
101487000	C - 11	6
101572101	Z - 25	46
101706001	C - 17	6
102538007	A - 30-3	2
102571003	F - 59	16
104450109	A - 29	2
104525001	K - 15	24
104567001	J - 12	22
104689002	H - 2	20
106129001	A - 30-4	2
106129002	M - 12-5	28
106147002	M - 15	28
	N - 15	30
106436001	J - 36	22
106588003	M - 22-3	28
107038003	D3- 76	12
107093002	M - 21	28
107149001	J - 32	22
	J - 34	22
107155001	J - 33	22
107231002	A - 52	2
	A - 7	2
107321003	F - 49	14
107415016	C - 30	6
	Z - 39	46
107606001	K - 15	24
107744001	F - 60	16
107779001	Z - 26	46
107780001	Z - 28	46
109239002	A - 20	2
110146001	M - 31	28
110161004	F - 20	14
110161006	U - 35	42
110168001	D1- 1-2-20	8
110367001	M - 27	28
	N - 20	30
110494001	H - 10	20
110735001	E - 14	12
111140002	M - 47	28
111466101	F - 35	14
112751003	K - 6	24
	P - 45	32
113006001	H - 35	20
113316001	K - 5	24
113431002	Q - 9	34
114294001	K - 10	24
114483002	Z - 33	46
114486002	B - 9	4
115183101	L - 5	26
115186001	K - 20	24
115188001	K - 22	24
115559002	F - 28	14
	U - 34	42
116662003	U - 38	42
116694001	U - 47	42
116922001	K - 13	24

CODE	REF.NO.	PAGE
117150001	J - 18	22
	J - 29	22
117934009	A - 13	2
117936009	A - 28	2
118064001	Z - 31	46
118837001	Z - 24	46
119702004	U - 1-3	42
119707003	U - 44	42
119708001	U - 45	42
120448001	L - 1-19	26
122991001	Z - 22	46
123006001	H - 7-1	20
126863001	Z - 36-10	46
132051001	C - 19-4	6
133172003	U - 1-1-2	42
133188001	U - 43	42
133740006	U - 1-16	42
138444001	U - 40	42
140263000	F - 25	14
140392009	A - 27	2
140726000	C - 7	6
141492001	M - 22-2	28
141550001	L - 1-4	26
141786001	H - 1	20
141808001	H - 27	20
142211001	C - 21	6
142268001	J - 3	22
	P - 16	32
142443001	Z - 23	46
142566001	L - 1-13	26
142721001	Z - 30	46
143549000	P - 12-4	32
143591001	D1- 1-1-18	8
	D1- 1-2-9	8
144105000	L - 1-32	26
144110001	L - 1-30	26
144458001	C - 26	6
	E - 24	12
144588001	K - 11	24
144712001	C - 2-1	6
145446001	K - 17	24
	K - 23	24
	L - 1-31	26
145472001	F - 36	14
145519001	K - 11	24
145646021	C - 30	6
	Z - 39	46
146020009	P - 11	32
146202000	P - 33	32
146255000	U - 1-15	42
146256001	U - 1-14	42
146288001	E - 18	12
148294001	L - 1-33	26
148425002	A - 54	2
	G - 3	18
148782001	D2- 80	10
148813001	M - 12-4	28
149547000	Q - 11	34
149796001	T - 6	40
150106003	Z - 36-4	46
150172003	Z - 36-3	46
150173003	Z - 36-4-1	46
150174000	Z - 36-2-3	46
	Z - 36-5	46
150179002	Z - 36-7-1	46
150180002	Z - 36-8	46
150182000	Z - 36-9	46

CODE	REF.NO.	PAGE
150191002	Z - 36-2-2	46
150206002	Z - 36-2-1	46
150551000	K - 12	24
150817101	N - 14	30
152236001	C - 19-2	6
152237001	C - 19-3	6
152243001	C - 28	6
152283101	F - 64	16
152510000	S - 1-19	36
152565000	S - 1-3-7	36
	Z - 3	46
152566000	S - 1-3-8	36
	Z - 29	46
152678001	H - 14	20
	H - 20	20
152681201	H - 22	20
152682001	H - 25	20
152683001	H - 18-3	20
152684101	H - 18-4	20
152686001	H - 25	20
152869001	K - 1	24
152870001	K - 3	24
152872001	K - 9	24
152881001	K - 24	24
152883000	K - 26	24
152884001	K - 27	24
152889001	K - 29	24
152891001	K - 32	24
152933001	L - 1-17	26
152936001	L - 1-5	26
152937001	L - 1-6	26
152940001	L - 1-10	26
152948001	J - 1	22
152955001	J - 8-2	22
152984001	L - 1-3	26
153098000	A - 30-2	2
153100000	A - 30	2
153102001	A - 30-1	2
153208002	A - 46	2
	A - 49	2
	F - 15	14
	G - 41	18
	G - 43	18
	G - 45	18
	M - 49	28
153330001	C - 19-1	6
153369001	D3- 74	12
153370001	D3- 75	12
153403002	D3- 9	12
153484001	F - 69	14
153597001	M - 12-2	28
153718001	A - 19	2
154465001	B - 7	4
154528001	L - 1-18	26
154607001	N - 7-3	30
154702001	Z - 34	46
154730001	P - 2-2	32
155487001	J - 28	22
155611001	N - 7-11	30
156112003	Z - 36-1	46
157968001	L - 1-24	26
159150009	U - 2	42
	V - 1-2-4	44
159224001	K - 7	24
159379001	F - 22	14
	F - 30	14
159486001	F - 50	14

CODE	REF.NO.	PAGE
159486001	L - 1-8	26
159574101	L - 1-27	26
159805001	K - 16	24
159905001	M - 14	28
159947001	P - 12-1	32
200190001	T - 15	40
	U - 1-20	42
	U - 3	42
228474000	Q - 5-1	34
228475000	Q - 5-2	34
231071001	M - 8	28
237941001	Q - 5	34
238033001	Q - 5-3	34
340400001	P - 44	32
	S - 18	38
	T - 25	40
402887001	H - 18-5	20
530138001	D2- 53	10
	G - 14	18
	G - 22	18
554482000	P - 18	32
625010000	A - 60	2
	P - 34	32
	P - 35	32

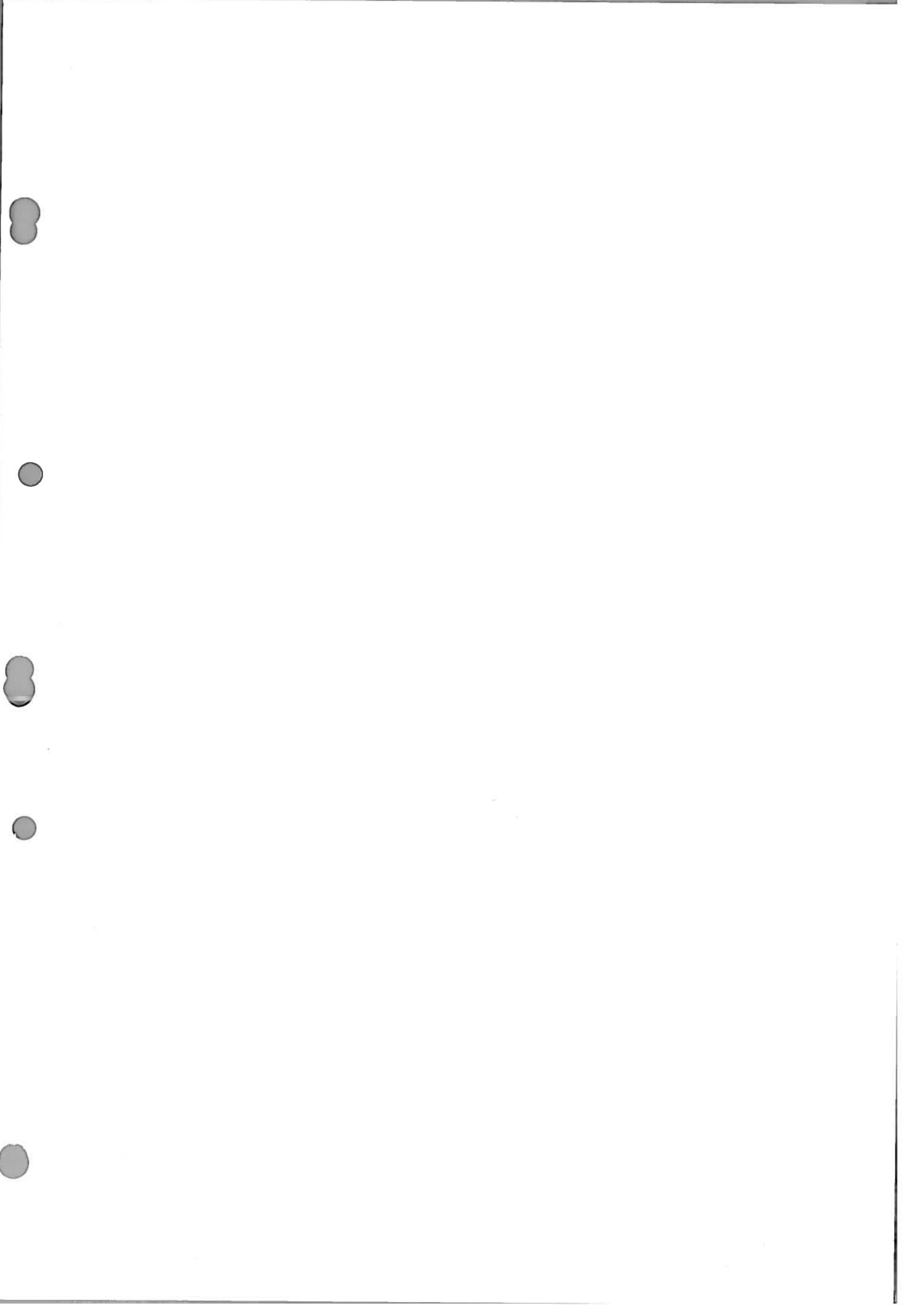

brother

ブラザー工業株式会社

〒467 名古屋市瑞穂区河岸一丁目1番1号
TEL (052) 824-2392代

BROTHER INDUSTRIES, LTD. NAGOYA, JAPAN

151-Z04
S98Z04-001
1993, 03, LⓅ

Printed in Japan/Gedruckt in Japan/Imprimé au Japon/Impreso en Japón