

brother

BAS-326A 326LA

プログラム式電子ミシン

PROGRAMMABLE ELECTRONIC PATTERN SEWER WITH CYLINDER BED

ELEKTRONISCH-FREI-PROGRAMMIERBARER STEPPSTICH-ZYLINDERARM-VOLLAUTOMAT

AUTOMATE DE COUTURE PROGRAMMABLE-BRAS CYLINDRIQUE

AUTOMATA ELECTRONICA PROGRAMABLE DE BASE CILINDRICA

PICK 022100402



PART: 326LA



PARTY CODE: BAS326A 326LA

We're at your side.
brother.

NCIA DE PIEZAS

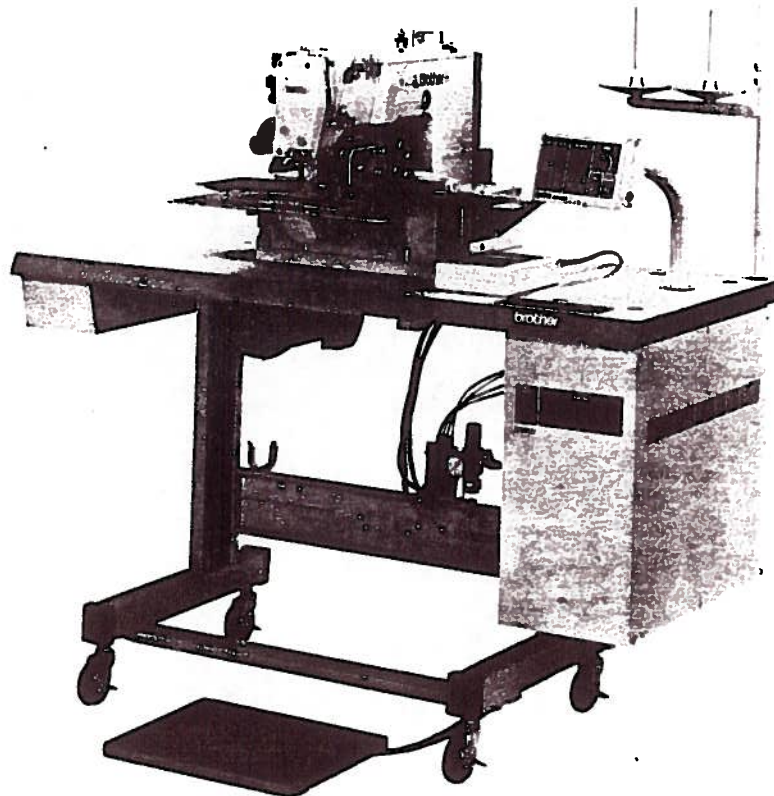

パーツブックご利用に際して

1. 組単位で補給する部品は、 破線で示しております。
2. この本は1992年12月のデータに基づいて作成されたものです。
3. 部品は予告なしに設計変更される場合があります。

目 次

A. 主体関係(1).....	2	P. 電装品関係.....	34
B. 主体関係(2).....	4	Q. 糸切れ感知関係.....	36
C. 上軸針棒関係.....	6	R. コントロールボックス関係.....	38
D1. 送り関係.....	8	S. 空圧関係.....	42
D2. 送り関係.....	10	T. プリント基板関係.....	44
E. 押エ上ゲ関係.....	14	U. 踏板関係.....	44
F. 駆動側・送り関係.....	18	V. 動力台関係.....	46
G. 下軸関係.....	20	W. 付属装置関係 (プログラマー)	48
H. 給油・潤滑関係.....	22	X1. 付属装置セット.....	48
J. 糸通シ関係.....	24	X2. ネーム付反転装置 エアー仕様 (オプション).....	50
K. 糸巻関係.....	26	X3. 付属装置セット.....	52
L. 糸切り関係.....	28	Z. 付属品関係.....	54
M. ワイパー関係.....	32	オプションパーツ.....	55~58
N. 針位置検出器関係.....	32	索引.....	59~66

Notes for using this parts book

1. Parts supplied as complete assemblies are circled by a dotted line .
2. This book was prepared based on information available in December 1992.
3. Parts are subject to changes in design without prior notice.

CONTENTS

A . Machine body (1)	2
B . Machine body (2)	4
C . Upper shaft and needle bar mechanism	6
D1 . Feed mechanism	8
D2 . Feed mechanism	10
E . Work Clamp Lifter mechanism	14
F . Feed guide mechanism	18
G . Lower shaft mechanism	20
H . Lubrication	22
J . Threading mechanism	24
K . Bobbin winder mechanism	26
L . Thread trimmer mechanism	28
M . Thread wiper mechanism	32
N . Synchronizer	32
P . Power supply equipment mechanism	34
Q . Thread breakage detector mechanism	36
R . Control box mechanism	38
S . Air pressure mechanism	42
T . Printed circuit board mechanism	44
U . Foot switch pedal mechanism	44
V . Power table	46
W . Programmer device	48
X1 . Attachment set	48
X2 . Reversing device for label sewing, pneumatic drive (option)	50
X3 . Attachment set	52
Z . Accessories	54
Optional parts	55 ~ 58
INDEX	59 ~ 66

Hinweise zur Verwendung dieser Teileliste

1. Die Teile, die als kompletter Satz geliefert werden, sind mit einer  gestrichelten Linie umrandet.
2. Dieses Buch basiert auf den Informationen vom Dezember 1992.
3. Modelländerungen sind vorbehalten.

INHALTSVERZEICHNIS

A .	Maschinengehäuse (1)	2
B .	Maschinengehäuse (2)	4
C .	Obere Welle und Nadelstangenvorrichtung	6
D1 .	Transportvorrichtung	8
D2 .	Transportvorrichtung	10
E .	Stoffhalterhebevorrichtung	14
F .	Transportführung	18
G .	Untere Welle	20
H .	Schmierung	22
J .	Fadenführungsvorrichtung	24
K .	Spuler	26
L .	Fadenabschneidevorrichtung	28
M .	Fadenwischvorrichtung	32
N .	Synchronisator	32
P .	Stromversorgung	34
Q .	Fadenbruchfühler	36
R .	Schaltkasten	38
S .	Luftdruck	42
T .	Leiterplatten	44
U .	Fußbetätigung	44
V .	Motorgestell	46
W .	Programmvorrichtung	48
X1 .	Anbausatz	48
X2 .	Umkehrvorrichtung zum Etikettannähen, pneumatische Betätigung (Sonderausrüstung)	50
X3 .	Anbausatz	52
Z .	Zubehör	54
	Sonderzubehör	55 - 58
	VERZEICHNIS	59 - 66

Notes sur l'utilisation de ce manuel de pièces détachées



1. Les pièces fournies en tant qu'assemblages complets sont encadrées avec un trait pointillé .
2. Ce manuel a été fait d'après les renseignements valables au mois de Décembre 1992.
3. Les pièces peuvent être sujettes à des modifications sans préavis.

TABLE DES MATIERES

A .	Corps de la machine (1)	2
B .	Corps de la machine (2)	4
C .	Mécanisme de arbre supérieur et barre à aiguille	6
D1 .	Mécanisme de l'entraînement	8
D2 .	Mécanisme de l'entraînement	10
E .	Mécanisme de leueur du pinceur	14
F .	Mécanisme du guide de l'entraînement	18
G .	Mécanisme de l'arbre inférieur	20
H .	Lubrification	22
J .	Mécanisme de l'enfilage	24
K .	Mécanisme du bobineur	26
L .	Mécanisme de coupe-fil	28
M .	Mécanisme de tire-fil	32
N .	Synchronisateur	32
P .	Mécanisme de l'équipement en alimentation électrique	34
Q .	Mécanisme du détecteur de cassure du fil	36
R .	Mécanisme du boîtier de contrôle	38
S .	Mécanisme de la pression d'air	42
T .	Circuits imprimés	44
U .	Mécanisme de la pédale	44
V .	Mécanisme du plateau de la machine	46
W .	Dispositif du programmeur	48
X1 .	Jeu d'accessoires	48
X2 .	Dispositif d'inversion pour la couture d'étiquettes, entraînement pneumatique (en option)	50
X3 .	Jeu d'accessoires	52
Z .	Accessoires	54
	Pieces en option	55 ~ 58
	INDEX	59 ~ 66

Notas para usar este Manual de Piezas

1. Las piezas suministradas como conjuntos completos se enmarcan con una línea punteada .
2. Este libro ha sido compilado basándose en los datos de que se disponía en diciembre 1992.
3. Las piezas quedan sujetas a cambios de diseño sin aviso previo.

INDICE

A .	Cuerpo de la máquina (1)	2
B .	Cuerpo de la máquina (2)	4
C .	Mecanismo del eje superior y la barra de aguja	6
D1.	Mecanismo de la alimentación	8
D2.	Mecanismo de la alimentación	10
E .	Mecanismo del levantador de ménsula de trabajo	14
F .	Mecanismo de la guía de alimentación	18
G .	Mecanismo del eje inferior	20
H .	Lubricación	22
J .	Mecanismo del enhebrado	24
K .	Mecanismo del devanador de la canilla	26
L .	Mecanismo de la cortadura de hilos	28
M.	Mecanismo de limpiador de hilos	32
N .	Sincronizador	32
P .	Mecanismo del equipo de alimentación de corriente	34
Q .	Mecanismo del sensor de cortes de hilo	36
R .	Mecanismo de la caja de controles	38
S .	Mecanismo de la presión de aire	42
T .	Tableros de circuitos impresos	44
U .	Mecanismo del pedal	44
V .	Mecanismo de la mesa de la máquina	46
W .	Programadora	48
X1.	Juego de fijación	48
X2.	Dispositivo de inversión para costura de etiquetas, mando neumático (opcional)	50
X3.	Juego de fijación	52
Z .	Accesorios	54
	Piezas opción	55 ~ 58
	INDICE	59 ~ 66

A. 主体関係(1) / Machine body (1) / Maschinengehäuse (1) /
 Corps de la machine (1) / Cuerpo de la máquina (1)

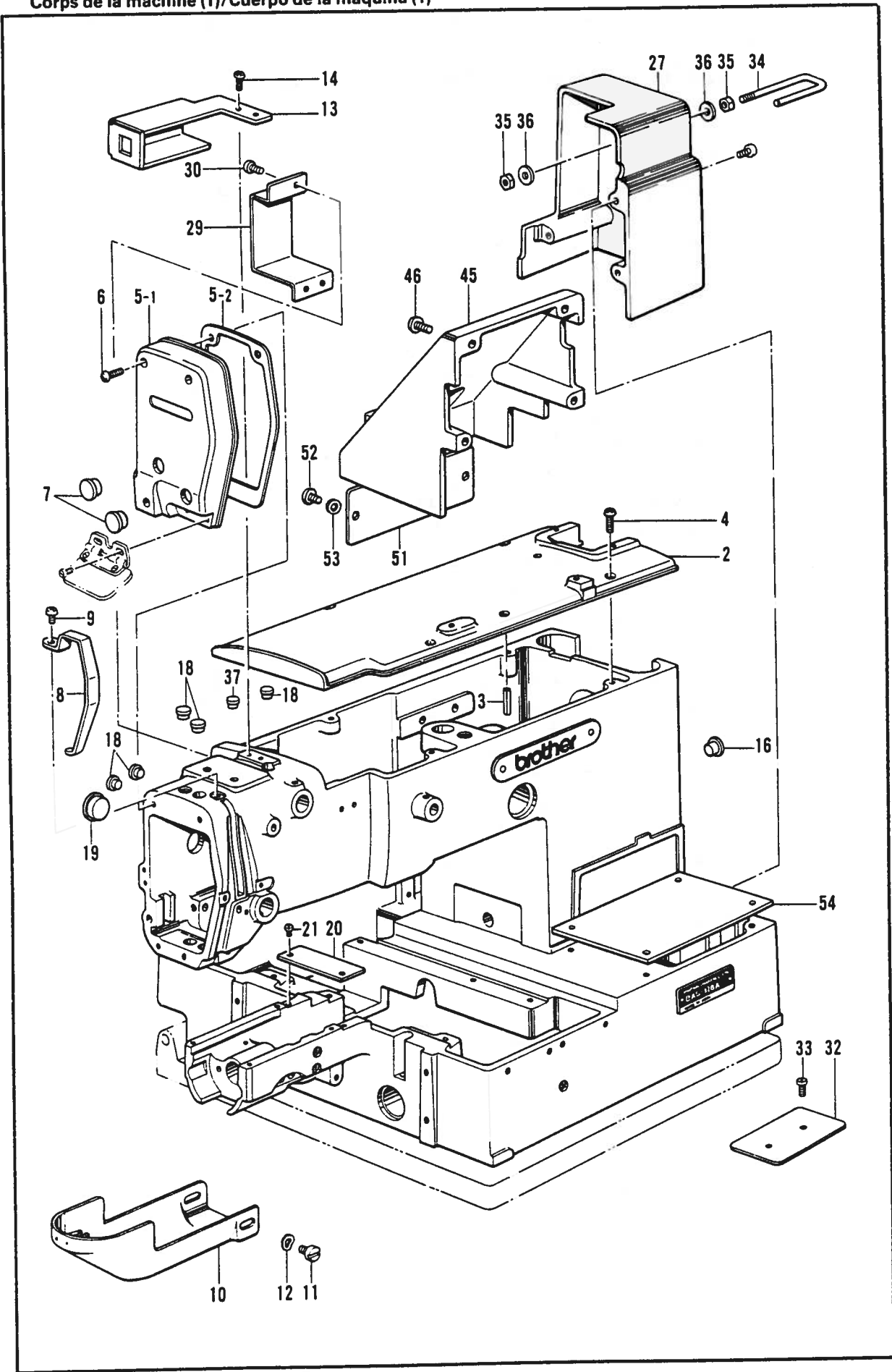

A. 主体関係(1) /Machine body (1)/Maschinengehäuse (1)/
Corps de la machine (1)/Cuerpo de la máquina (1)

REF.NO.	CODE	Q'TY	ヒンメイ	NAME OF PARTS	RMKS
2	S15149003	1	ウツフタ	TOP COVER	
3	047503242	1	スプリングピンAW5	SPRING PIN AW5	
4	062761412	4	ナヘコ595-28X14	SCREW 595X14	
5	S16123003	1	メンイタクミ	FACE PLATE ASSY	
5-1	S16124003	1	メンイタ	FACE PLATE	
5-2	S02229000	1	メンイタパツキン	PACKING	
6	062711412	3	ナヘコ4.76-32X14	SCREW 476X14	
7	117934009	2	メクラセン	OIL CAP	
8	152841109	1	テンピンカハ-	THREAD TAKE-UP COVER	
9	062670812	1	ナヘコ3.57-40X8	SCREW 3.57X8	
10	S02231103	1	オオカマカハークミ	LARGE SHUTTLE HOOK COVER ASSY	
11	113745001	2	タネシ5.95	STUD SCREW 5.95	
12	109239002	2	ナミハネサカネ	WAVE SPRING WASHER	
13	S14432003	1	EMスイッチイタ	EM-SWITCH PLATE	
14	062711012	2	ナヘコ476-32X10	SCREW 4.76X10	
16	104449009	1	メクラセン	OIL CAP	
18	117936009	5	メクラセン	OIL CAP	
19	140392009	1	オイルフタ	OIL CAP	
20	S02242001	1	ハリイタカハ-	NEEDLE PLATE COVER	
21	153208002	2	シメネジ4.37	SCREW 4.37	
27	S15139009	1	ケンテンカハ-	HOME POSITION COVER	
29	S02484003	1	カンケツカハ-	INTERMITTENT COVER	
30	062670612	3	ナヘコ357-40X6	SCREW 3.57X6	
32	S03905000	1	オクリイカハ-B	FEED BASE COVER (B)	
33	153208002	2	シメネジ4.37	SCREW 4.37	
34	S03281001	1	ラックガード	RACK GUARD	
35	021500103	2	ナット1シユ5	NUT 5	
36	025050233	2	ヒラサカネチユウ5	PLAIN WASHER 5	
37	104450109	2	メクラセン	OIL CAP	
45	S31596009	1	ソクメンカハ-	FRAME SIDE COVER	
46	062711412	4	ナヘコ4.76-32X14	SCREW 476X14	
51	S31591009	1	ヘツトカハ-	BED COVER	
52	062680612	2	ナヘコ4.37-40X6	SCREW 4.37X6	
53	025680132	2	ヒラサカネシヨウ4.37	PLAIN WASHER 4.37	
54	S09198003	1	サイドカハ-RA	SIDE COVER (RA)	
55	062711012	1	ナヘコ476-32X10	SCREW 4.76X10	

B. 主体関係(2) / Machine body (2) / Maschinengehäuse (2) /
 Corps de la machine (2) / Cuerpo de la máquina (2)

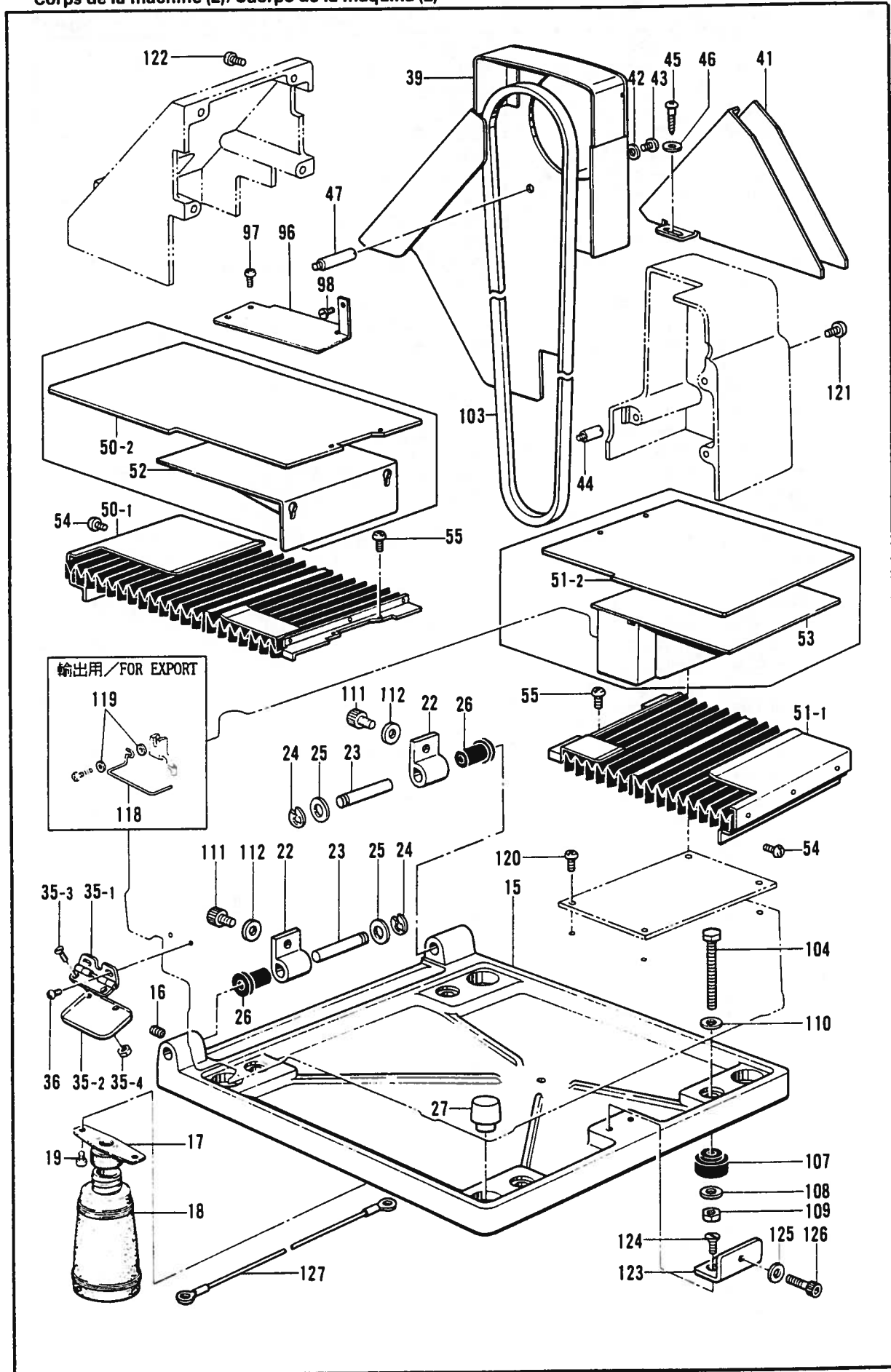

B. 主体関係(2) / Machine body (2) / Maschinengehäuse (2) /
Corps de la machine (2) / Cuerpo de la máquina (2)

REF NO.	CODE	Q'TY	ヒンメイ	NAME OF PARTS	RMKS
15	S02237003	1	ヘ"ツト"タイ	BED BASE	
16	014760622	2	アナメネシ"5.95	SET SCREW 5.95	
17	154465001	1	ハイユキヤツフ"ササエクミ	DUST OILER SUPPORT ASSY	
18	114486002	1	ホ"リオイラータイ	OILER	
19	062710612	2	ナヘ"コ476-32X6	SCREW 4.76X6	
22	S31608001	2	ヒンシ"	HINGE	
23	158831001	2	ヒンシ"ピン	PIN	
24	048080342	2	トメワE8	STOP RING E8	
25	025100132	2	ヒラサ"カ"ネシヨウ10	PLAIN WASHER 10	
26	158832000	2	ヒンシ"ピンササエゴム	PIN SUPPORT RUBBER	
27	152860009	4	ヘ"ツト"クツシヨシ	BED CUSHION	
35	S02872001	1	アイカ"ート"クミ	EYE GUARD ASSY	
35-1	153102001	1	アイカ"ート"チヨウハ"ンクミ	EYE GUARD HINGE ASSY	
35-2	S02359000	1	アイカ"ート"	EYE GUARD	
35-3	102538007	2	サラネシ"3.57	SCREW 3.57	
35-4	106129001	2	ナツト3.57	NUT 3.57	
36	062670512	2	ナヘ"コ357-40X5	SCREW 3.57X5	
39	S15146009	1	ヘ"ルトカハ"	BELT COVER	
41	S15159009	1	ヘ"ルトカハ"-D	BELT COVER (D)	
42	025710232	2	ヒラサ"カ"ネチユウ4.76	PLAIN WASHER 4.76	
43	062710612	2	ナヘ"コ476-32X6	SCREW 4.76X6	
44	149853001	1	スタツト"S	STUD (S)	
45	100666002	2	マルモクネシ"5.5X20	SCREW 5.5X20	
46	025750132	2	ヒラサ"カ"ネシヨウ5.56	PLAIN WASHER 5.56	
47	S15148001	2	スタツト"A	STUD (A)	
50-1	S07799001	1	シヤハ"ラLクミ150	BELLOW (L) ASSY (150)	
51-1	S07795001	1	シヤハ"ラRクミ150	BELLOW (R) ASSY (150)	
54	062670612	4	ナヘ"コ357-40X6	SCREW 3.57X6	
55	062680812	4	ナヘ"コ437-40X8	SCREW 4.37X8	
96	S02483009	1	ヘ"ツト"カハ"	BED COVER	
97	062710612	2	ナヘ"コ476-32X6	SCREW 4.76X6	
98	100257010	1	シメネシ"3.57	SCREW 3.57	
103	S18707149	1	Vヘ"ルトMシロ	V BELT (M49)	
104	S21728001	4	ホ"ルト6X80	BOLT 6X80	
107	158827000	4	ヘ"ツト"クツシヨシA	BED BASE CUSHION (A)	
108	115947001	4	サ"カ"ネ	WASHER	
109	021060102	8	ナツト1シユ6	NUT 6	
110	025060332	4	ヒラサ"カ"ネタ"イ6	PLAIN WASHER 6	
111	018061222	2	アナホ"ルト6X12	BOLT 6X12	
112	025060232	2	ヒラサ"カ"ネチユウ6	PLAIN WASHER 6	
118	S02445001	1	-----	FINGER GUARD	
119	025350236	2	-----	PLAIN WASHER 3.5	
120	062710612	4	ナヘ"コ476-32X6	SCREW 4.76X6	
121	062711412	3	ナヘ"コ4.76-32X14	SCREW 476X14	
122	062711412	7	ナヘ"コ4.76-32X14	SCREW 476X14	
123	S10025001	1	ヘ"ツト"カケガ"ネ	BED LATCH	
124	107231002	2	サラネシ"4.76	SCREW 4.76	
125	100645003	1	サ"カ"ネ	WASHER	
126	018681022	1	アナホ"ルト4.37X10	BOLT 4.37X10	
127	S15157001	1	アースセン	EARTH WIRE	
<LA-タイプ (180MM)/LA-TYPE (180MM)>					
50-2	S10686000	1	オクリカハ"-L180	FEED COVER (L180)	
51-2	S10685000	1	オクリカハ"-R180	FEED COVER (R180)	
52	S10688101	1	オクリカハ"-ササエL	FEED COVER SUPPORT (L)	
53	S10687101	1	オクリカハ"-ササエR	FEED COVER SUPPORT (R)	

C. 上軸針棒関係 / Upper shaft and needle bar mechanism / Obere Welle und Nadelstangenvorrichtung /
 Mécanisme de arbre supérieur et barre à aiguille / Mecanismo del eje superior y la barra de aguaja

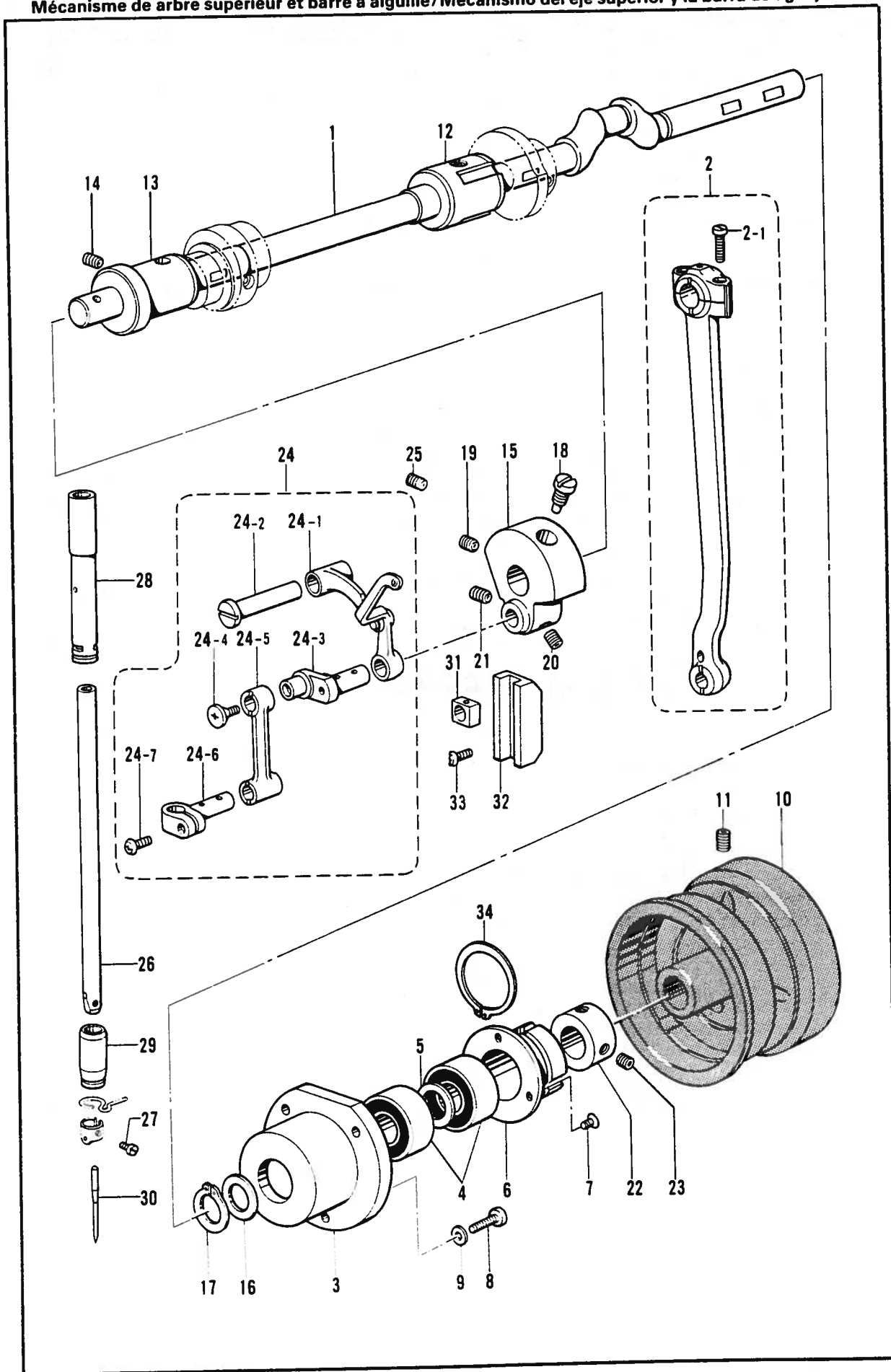

C. 上軸針関係 / Upper shaft and needle bar mechanism / Obere Welle und Nadelstangenvorrichtung /
 Mécanisme de arbre supérieur et barre à aiguille / Mecanismo del eje superior y la barra de aguja

REF.NO	CODE	Q'TY	ヒンメイ	NAME OF PARTS	RMKS
1	S14433001	1	ウツジク	UPPER SHAFT	
2	S02258001	1	クランクロッドクミ	CRANK ROD ASSY	
2-1	144712001	2	シメネシ"4.76	SCREW 4.76	
3	S02260000	1	タマシクウケケース	BALL BEARING CASE	
4	S15138001	2	タマシクウケ6202VVCM	BALL BEARING 6202VVCM	
5	141275001	1	タマシクウケカラー	WASHER	
6	S14434001	1	タマシクウケフタ	BALL BEARING CASE CAP	
7	102843004	3	サラネシ"3.57	SCREW 3.57	
8	062681412	3	ナヘ"コ437-40X14	SCREW 4.37X14	
9	025680232	3	ヒラサ"ガ"ネチユウ4.37	PLAIN WASHER 4.37	
10	S14436009	1	プーリー	PULLEY	
11	014061631	2	アトメネシ"6X16クホ"ミ	SET SCREW 6X16	
12	140726000	1	ウツジクメタルM	UPPER SHAFT BUSH (M)	
13	S02263001	1	ウツジクメタルF	UPPER SHAFT BUSH (F)	
14	013761412	1	トメネシ"5.95クホ"ミ	SET SCREW 5.95	
15	152231000	1	ツリアイクランク	COUNTER WEIGHT	
16	116920001	1	オクリシ"クスラストリング"	THRUST RING	
17	048150142	1	トメウツジクヨウC15	STOP RING C15	
18	100250001	1	シメネシ"7.14	SCREW 7.14	
19	014770622	1	アトメネシ"6.35クホ"ミ	SET SCREW 6.35	
20	101706001	1	トメネシ"6.35	SET SCREW 6.35	
21	014770622	1	アトメネシ"6.35クホ"ミ	SET SCREW 6.35	
22	S02446001	1	セツトカラー	SET COLLAR	
23	014770622	2	アトメネシ"6.35クホ"ミ	SET SCREW 6.35	
24	S02265001	1	ハリホ"ウレンカンクミ	THREAD TAKE-UP LEVER ASSY	
24-1	153330001	1	デンヒ"ンクミ	THREAD TAKE-UP ASSY	
24-2	152236001	1	デンヒ"ンササエシ"ク	THREAD TAKE-UP SUPPORT STUD	
24-3	152237001	1	ハリホ"ウクランク	NEEDLE BAR CRANK	
24-4	132051001	1	+サラネシ"3.57L	SCREW 3.57L	
24-5	S02267001	1	ハリホ"ウレンカン	THREAD TAKE-UP LEVER	
24-6	S02268001	1	ハリホ"ウタ"キ	NEEDLE BAR CLAMP	
24-7	062680812	1	ナヘ"コ437-40X8	SCREW 4.37X8	
25	014760622	1	アトメネシ"5.95	SET SCREW 5.95	
26	S02269001	1	ハリホ"ウ	NEEDLE BAR	
27	144458001	1	アタマツキトメネシ"3.57	SET SCREW 3.57	
28	152242001	1	ハリホ"ウメタルU	NEEDLE BAR BUSH (U)	
29	S02270001	1	ハリホ"ウメタルD	NEEDLE BAR BUSH (D)	
30	145646019	1	ミシンハリDPX17(#19)	NEEDLE DPX17 (#19)	
31	142211001	1	カクコマ	SLIDE BLOCK	
32	S02271001	1	ハリホ"ウアンナイ	NEEDLE BAR GUIDE	
33	062681012	2	ナヘ"コ437-40X10	SCREW 4.37X10	
34	S10383001	1	トメウツジクヨウC36	STOP RING C36	
<オプションパーツ / OPTION PARTS>					
30	107415009	1	ミシンハリDPX5(#9)	NEEDLE DPX5 (#9)	
30	107415011	1	ミシンハリDPX5(#11)	NEEDLE DPX5 (#11)	
30	107415014	1	ミシンハリDPX5(#14)	NEEDLE DPX5 (#14)	
30	107415016	1	ミシンハリDPX5(#16)	NEEDLE DPX5 (#16)	
30	107415018	1	ミシンハリDPX5(#18)	NEEDLE DPX5 (#18)	
30	107415021	1	ミシンハリDPX5(#21)	NEEDLE DPX5 (#21)	
30	107415023	1	ミシンハリDPX5(#23)	NEEDLE DPX5 (#23)	
30	154763010	1	ミシンハリDPX5KN(#10)	NEEDLE DPX5KN (#10)	
30	145646014	1	ミシンハリDPX17(#14)	NEEDLE DPX17 (#14)	
30	145646016	1	ミシンハリDPX17(#16)	NEEDLE DPX17 (#16)	
30	145646018	1	ミシンハリDPX17(#18)	NEEDLE DPX17 (#18)	
30	145646019	1	ミシンハリDPX17(#19)	NEEDLE DPX17 (#19)	
30	145646021	1	ミシンハリDPX17(#21)	NEEDLE DPX17 (#21)	
30	145646024	1	ミシンハリDPX17(#24)	NEEDLE DPX17 (#24)	
30	145646025	1	ミシンハリDPX17(#25)	NEEDLE DPX17 (#25)	

D1. 送り関係/Feed mechanism/Transportvorrichtung/
 Mécanisme de l'entraînement/Mecanismo de la alimentación

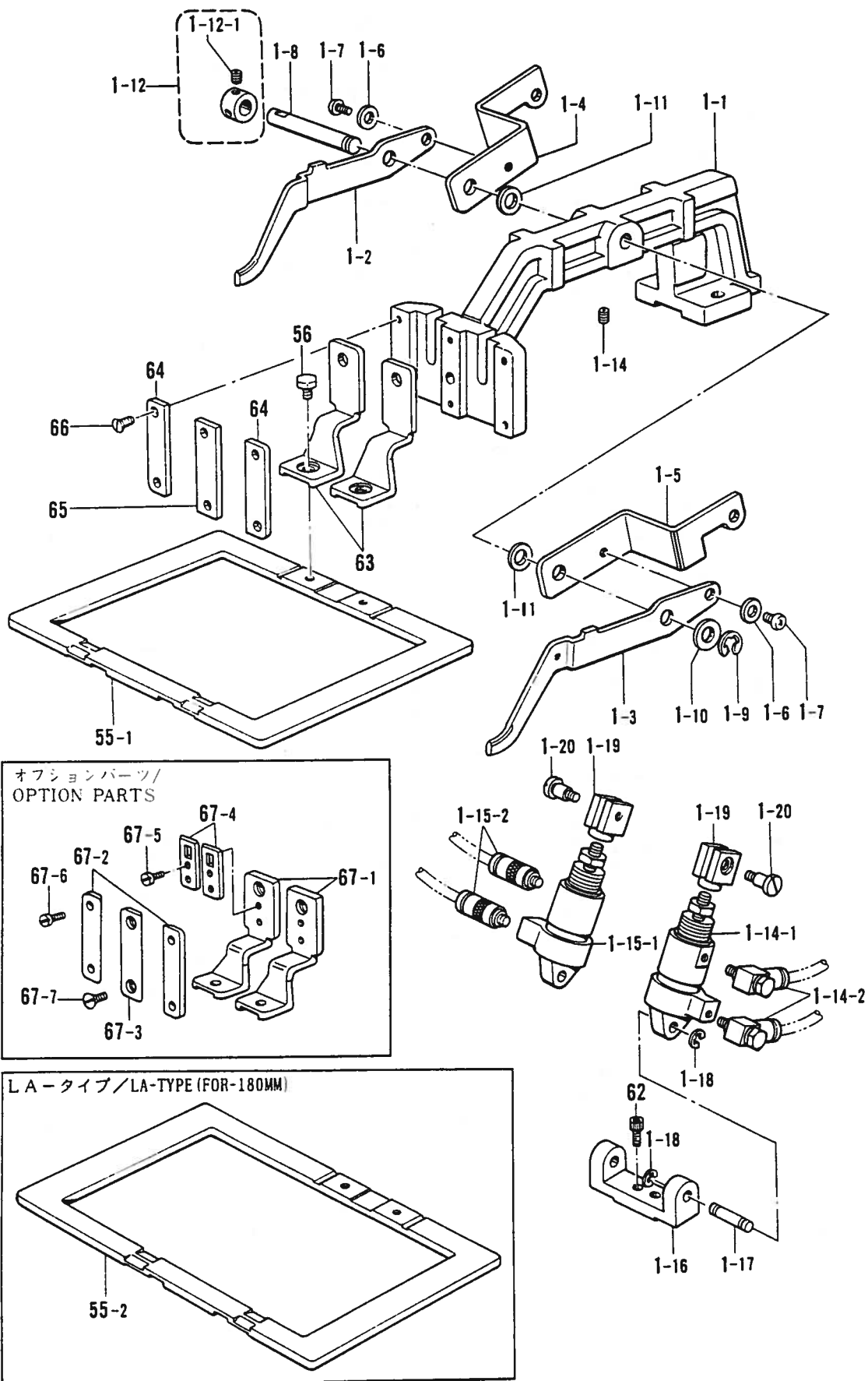

D1. 送り関係/Feed mechanism/Transportvorrichtung/
 Mécanisme de l'entraînement/Mecanismo de la alimentación

REF NO	CODE	Q'TY	ヒンメイ	NAME OF PARTS	RMKS
1	S03805009	1	オサイウテ"クミAA	PRESSER ARM ASSY (AA)	
1-1	S03802009	1	オサイウテ"	PRESSER ARM	
1-2	S03806001	1	オサイウテ"レハ"-AL	PRESSER LEVER (AL)	
1-3	S03807001	1	オサイウテ"レハ"-AR	PRESSER LEVER (AR)	
1-4	S03809001	1	オサイウテ"レハ"-BL	PRESSER LEVER (BL)	
1-5	S03810001	1	オサイウテ"レハ"-BR	PRESSER LEVER (BR)	
1-6	025680232	2	ヒラサ"カ"ネチユウ4.37	PLAIN WASHER 4.37	
1-7	062680612	2	ナヘ"コ4.37-40X6	SCREW 4.37X6	
1-8	S02284001	1	オサイウテ"レハ"-シ"ク	PRESSER ARM LEVER SHAFT	
1-9	048060342	1	トメワE6	STOP RING E6	
1-10	100197002	1	サ"カ"ネ	WASHER	
1-11	143591001	2	スラストリング"	THRUST RING	
1-12	S21775001	1	セツトカラー"クミ	SET COLLAR ASSY	
1-12-1	014680422	2	アナトメネシ"4.37クホ"ミ	SET SCREW 4.37	
1-13	014760622	1	アナトメネシ"5.95	SET SCREW 5.95	
1-14	S15079001	1	エアシリンダ"クミR	AIR CYLINDER ASSY (R)	
1-14-1	S03797101	1	エアシリンダ"	AIR CYLINDER	
1-14-2	S03820000	2	エルボ" M5	ELBOW M5	
1-15	S15080001	1	エアシリンダ"クミL	AIR CYLINDER ASSY (L)	
1-15-1	S03797101	1	エアシリンダ"	AIR CYLINDER	
1-15-2	S18415001	2	ハーフユニオンQ4M5	HALF UNION	
1-16	S03799001	1	シリンダ"ササイ	CYLINDER SUPPORT	
1-17	S03800001	2	クレビス"ピン	CLEVIS PIN	
1-18	048040342	4	トメワE4	STOP RING E4	
1-19	S03801001	2	シリンダ"ツキ"テ	CYLINDER JOINT	
1-20	110168001	2	コロシ"ク	ROLLER SHAFT	
55-1	S07802001	1	オサイI150	WARK CLAMP PRESSER (150)	
56	017680512	2	ボ"ルト4.37X5	BOLT 4.37X5	
62	018501222	2	アナボ"ルト5X12	BOLT 5X12	
63	S02288001	2	オサイアシM	WORK CLAMP (M)	
64	153369001	2	オサイアシオサイイタA	WORK CLAMP GUIDE PLATE (A)	
65	153370001	1	オサイアシオサイイタB	WORK CLAMP GUIDE PLATE (B)	
66	107038003	6	サラネシ"3.57	SCREW 3.57	
<LA-タイプ (180MM)/LA-TYPE (180MM)>					
55-2	S10683001	1	オサイI180	WARK CLAMP PRESSER (180)	
<オプションパーツ /OPTION PARTS>					
67	S21713001	1	オサイアシSE-L"クミ	WORK CLAMP (SE-L)ASSY	
67-1	S21700001	2	オサイアシML	WORK CLAMP (ML)	
67-2	S21714001	2	オサイアシオサイイタAL	WORK CLAMP PRESSER PLATE (AL)	
67-3	S21698001	1	オサイアシオサイイタBL	WORK CLAMP PRESSER PLATE (BL)	
67-4	S21699001	2	オサイアシイタL	WORK CLAMP PLATE (L)	
67-5	100242003	4	シメネシ"3.57	SCREW 3.57	
67-6	100257010	4	シメネシ"3.57	SCREW 3.57	
67-7	107038003	2	サラネシ"3.57	SCREW 3.57	

D2. 送り関係 / Feed mechanism / Transportvorrichtung /
 Mécanisme de l'entraînement / Mecanismo de la alimentación

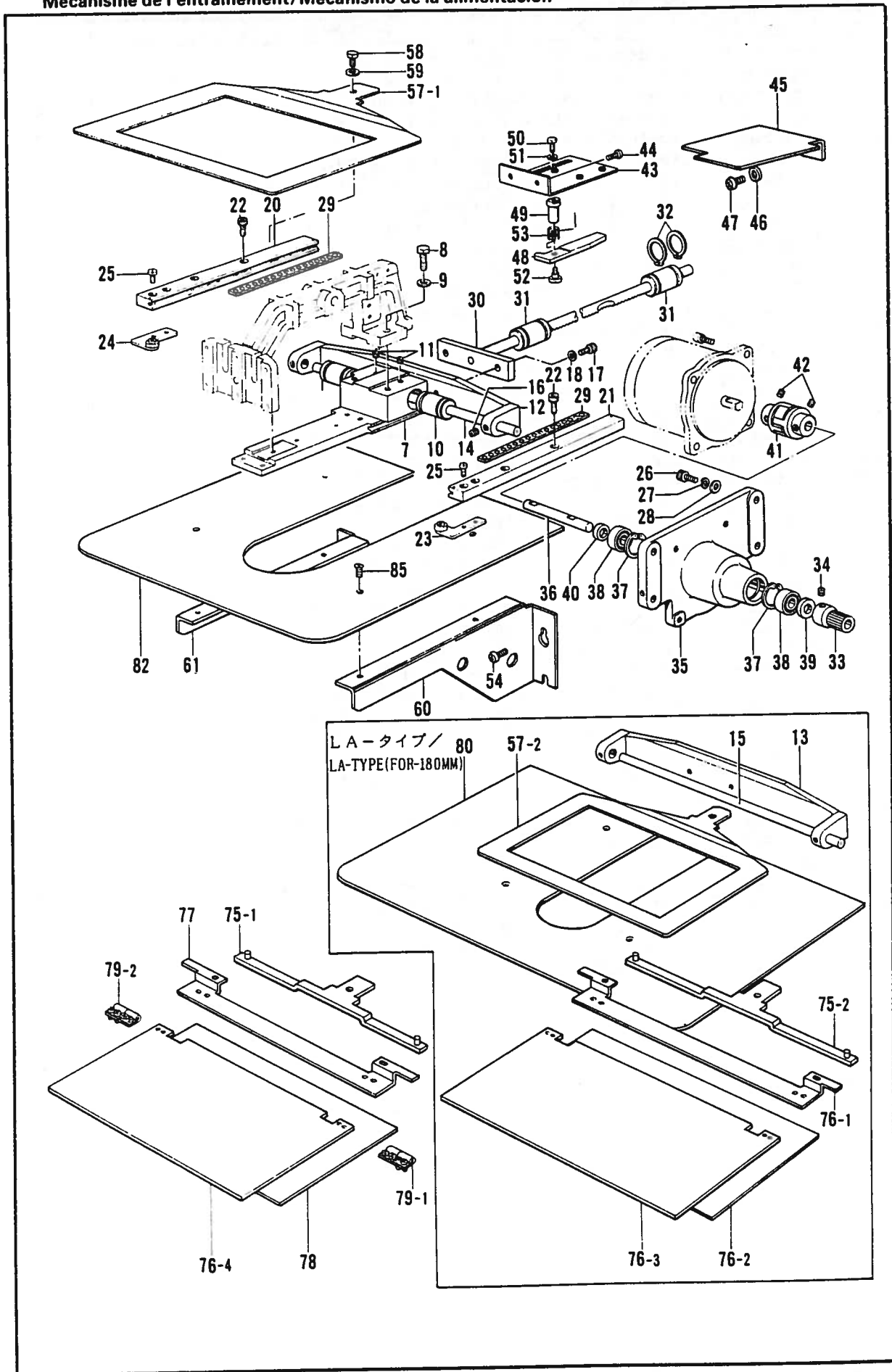

D2. 送り関係/Feed mechanism/Transportvorrichtung/
Mécánisme de l'entraînement/Mecanismo de la alimentación

REF.NO.	CODE	Q'TY	ヒンメイ	NAME OF PARTS	RMKS
7	S02387001	1	オクリタ"イY	Y-FEED BRACKET	
8	017761412	2	ボ"ルト5.95X14	BOLT 5.95X14	
9	025060132	2	ヒラサ"カ"ネシヨウ6	PLAIN WASHER 6	
10	S03899000	2	ホ"ールフ"ツシユV	BALL BUSH (V)	
11	011679312	4	トメネシ"3.57ヒラ	SET SCREW 3.57	
12	S31600009	1	Xオクリシ"クササE150	X-FEED SHAFT SUPPORT (150)	
14	S31602001	1	Xオクリシ"ク150	X-FEED SHAFT (150)	
16	014760622	2	アナトメネシ"5.95	SET SCREW 5.95	
17	018500822	2	アナボ"ルト5X8	BOLT 5X8	
18	S03677001	2	サ"カ"ネ	WASHER	
20	S03293001	1	YオクリアンナイLクミ	Y-FEED GUIDE (L) ASSY	
21	S03294001	1	YオクリアンナイRクミ	Y-FEED GUIDE (R) ASSY	
22	018681022	4	アナボ"ルト4.37X10	BOLT 4.37X10	
23	S02392001	1	オクリコロRクミ	FEED ROLLER (R) ASSY	
24	S02396001	1	オクリコロLクミ	FEED ROLLER (L) ASSY	
25	153208002	4	シメネシ"4.37	SCREW 4.37	
26	018401222	4	アナボ"ルト4X12	BOLT 4X12	
27	028040242	4	ハ"ネサ"カ"ネ2-4	SPRING WASHER 2-4	
28	025040232	4	ヒラサ"カ"ネチユウ4	PLAIN WASHER 4	
29	S02398100	2	Yリテ"ナクミ	Y-RETAINER ASSY	
30	S29735101	1	Yラツク	Y-RACK	
31	S02401000	2	ホ"ールフ"ツシユ	BALL BUSH	
32	S02460001	4	トメワシ"クヨウC19	STOP RING C19	
33	S02403001	1	クト"ウキ"ヤ	ACTUATING GEAR	
34	014760622	2	アナトメネシ"5.95	SET SCREW 5.95	
35	S31597001	1	Yクト"ウPモ"ータフ"ラケツト	Y-DRIVING SHAFT P MOTOR BRACKET	
36	S31598001	1	Yクト"ウキ"ヤシ"ク	Y-DRIVING GEAR SHAFT	
37	048220242	2	トメワ"アナヨウC22	STOP RING C22	
38	S17868001	2	ミニチュアタマシ"クウケ	MINIATURE BALL BEARING	
39	S00772001	1	カンサ"	WASHER	
40	S31599001	1	カンサ"	WASHER	
41	S23446000	1	カツフ"リング"	COUPLING	
42	014760622	4	アナトメネシ"5.95	SET SCREW 5.95	
43	S02405001	1	Yケ"ンテンタ"イ	Y-AXIS HOME POSITION BASE	
44	062711012	2	ナヘ"コ476-32X10	SCREW 4.76X10	
45	S15140001	1	Yケ"ンテンカハ"ー	Y-AXIS HOME POSITION COVER	
46	025350132	2	ヒラサ"カ"ネシヨウ	PLAIN WASHER	
47	062670812	2	ナヘ"コ3.57-40X8	SCREW 3.57X8	
48	S02406001	1	Yケ"ンテント"ク"	Y-AXIS HOME POSITION DOG	
49	S02473101	1	Yケ"ンテンシ"ク	Y-AXIS HOME POSITION SHAFT	
50	017681012	1	ボ"ルト4.37X10	BOLT 4.37X10	
51	025050232	1	ヒラサ"カ"ネチユウ-5	PLAIN WASHER 5	
52	146597101	1	タ"ンネシ"4.37	STUD SCREW 4.37	
53	S02479001	1	Yケ"ンテンハ"ネ	SPRING	
54	062761012	4	ナヘ"コ595-28X10	SCREW 595X10	
57-1	S07803001	1	オクリイタ150	FEED PLATE (150)	
58	153403002	1	ボ"ルト4.37X7	BOLT 4.37X7	
59	025680232	1	ヒラサ"カ"ネチユウ4.37	PLAIN WASHER 4.37	
60	S02444001	1	ホシ"ヨイタササER	SUPPORT PLATE GUIDE (R)	
61	S02873001	1	ホシ"ヨイタササEL	SUPPORT PLATE GUIDE (L)	
75-1	S02963001	1	カセツトシシ"イタクミ	CASSETTE HOLDER PLATE ASSY	
76-4	S02971000	2	カセツトイタU-B	CASSETTE PLATE U-B	
77	S02967101	2	カセツトイタD-B	CASSETTE PLATE D-B	
78	S02969000	2	カセツトシタイA	CASSETTE LOWER PLATE (A)	
79-1	152632001	2	チヨウハ"ンクミミキ"	HINGE ASSY (R)	
79-2	152633001	2	チヨウハ"ンクミヒタ"リ	HINGE ASSY (L)	
82	S02443001	1	ホシ"ヨイタL	SUPPORT PLATE (L)	
85	100032004	4	サラネシ"4.37	SCREW 4.37	
<LA-タイプ (180MM)/LA-TYPE (180MM)>					
13	S31601009	1	Xオクリシ"クササE180	X-FEED SHAFT SUPPORT (180)	
15	S31603001	1	Xオクリシ"ク180	X-FEED SHAFT (180)	
57-2	S10684001	1	オクリイタ180	FEED PLATE (180)	

D2. 送り関係/Feed mechanism/Transportvorrichtung/
 Mécanisme de l'entraînement/Mecanismo de la alimentación

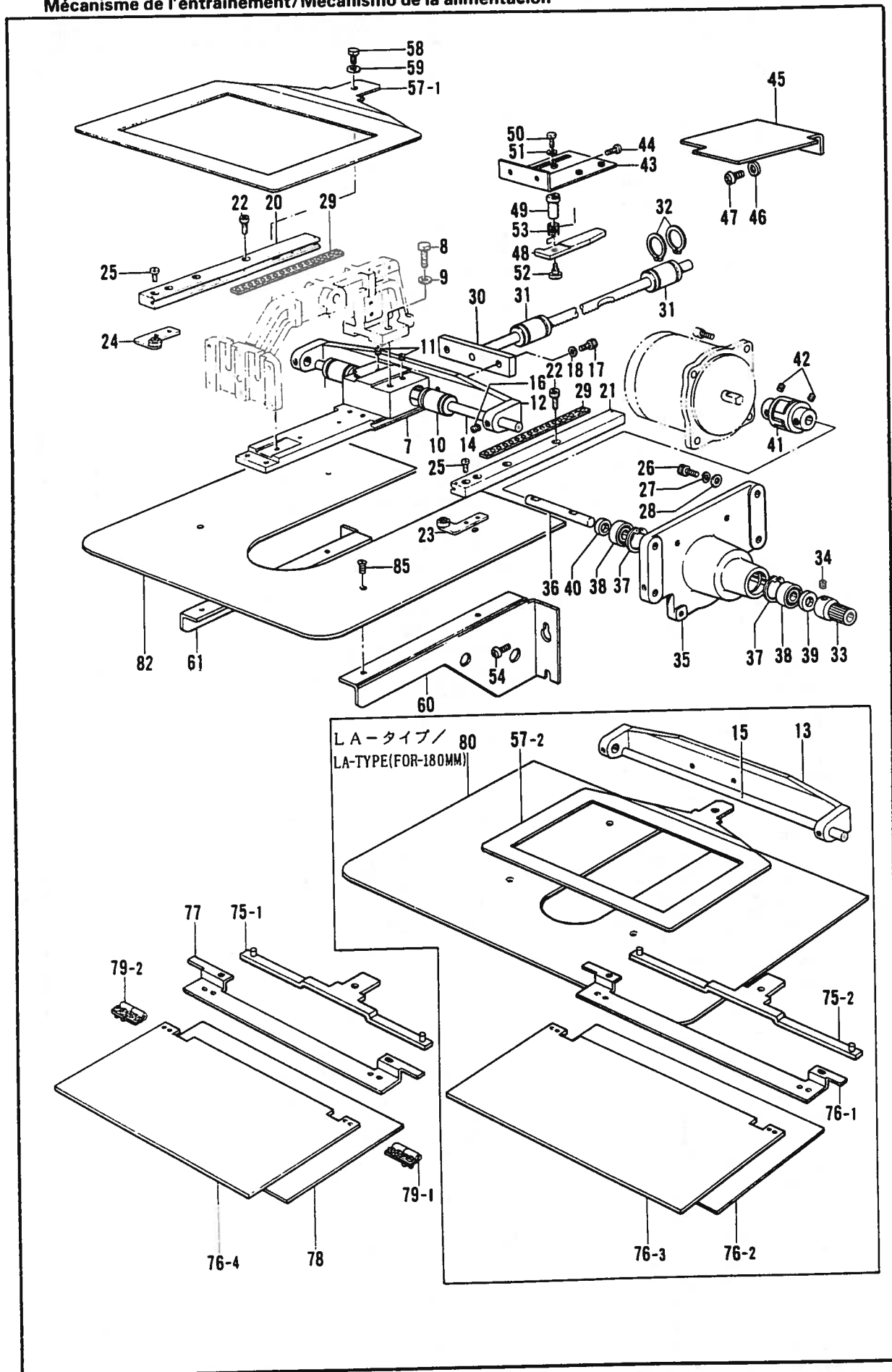

D2. 送り関係/Feed mechanism/Transportvorrichtung/
 Mécanisme de l'entraînement/Mecanismo de la alimentación

REF. NO.	CODE	Q'TY	品名	NAME OF PARTS	RMKS
75-2	S14384001	1	カセットシシ"イタクミ180	CASSETTE HOLDER PRATE ASSY (180)	
76-1	S14388101	2	カセットイタD-B180	CASSETTE PLATE D-B180	
76-2	S14386000	2	カセットシタイタA180	CASSETTE LOWER PLATE A-180	
76-3	S14390000	2	カセットイタU-B180	CASSETTE PLATE U-B180	
79-1	152632001	2	チヨウハ"ンクミミキ"	HINGE ASSY (R)	
79-2	152633001	2	チヨウハ"ンクミヒタ"リ	HINGE ASSY (L)	
80	S10682001	1	ホジ"ヨイタ180	SUPPORT PLATE (180)	

E. 押工上付関係 / Work clamp lifter mechanism / Stoffhalterhebevorrichtung /
 Mécanisme de leveur du pinceur / Mecanismo del levantador de ménsula de trabajo

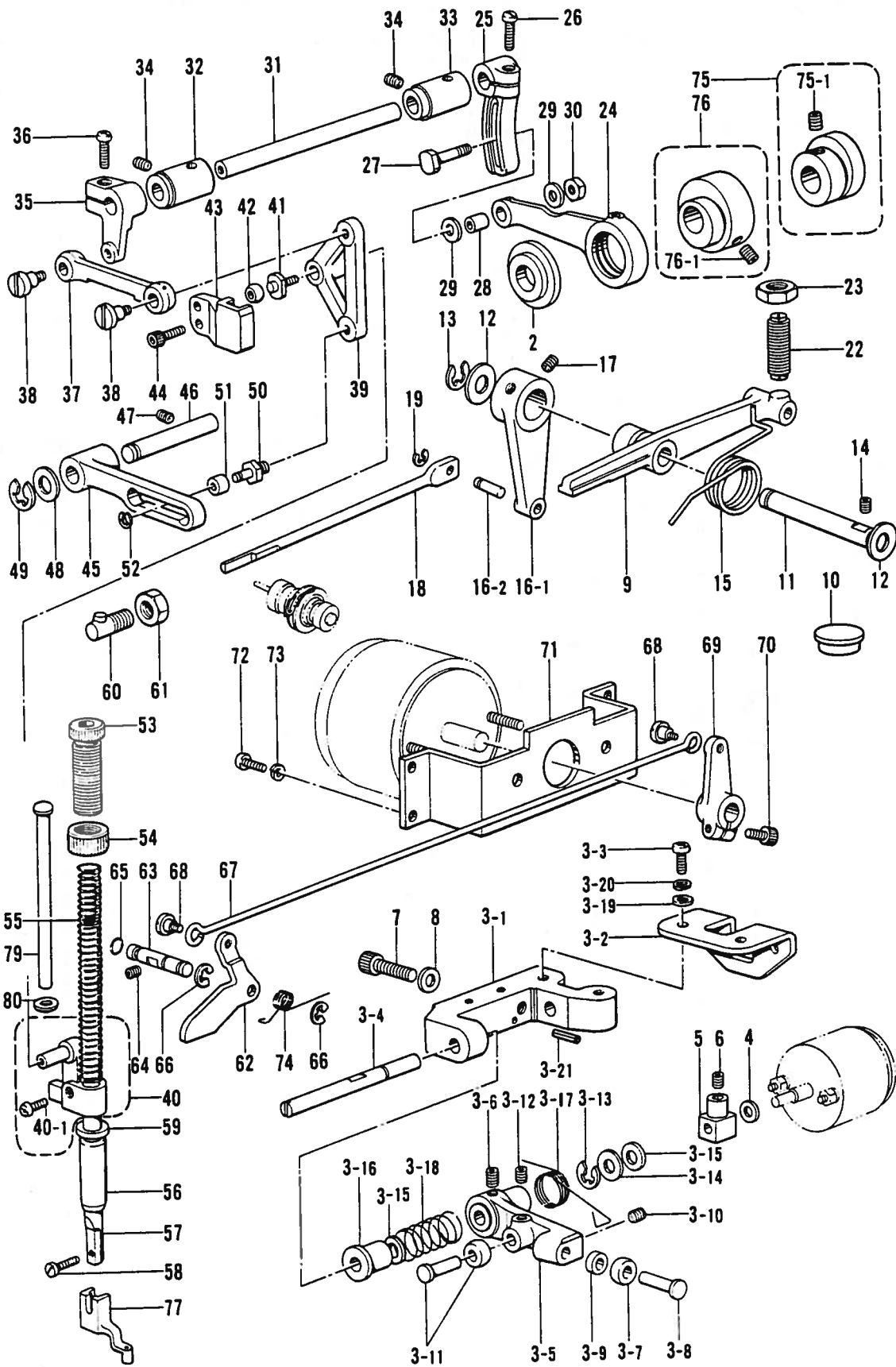

E. 押工上げ関係/Work clamp lifter mechanism/Stoffhalterhebevorrichtung/
Mécanisme de leveur du pinceur/Mecanismo del levantador de ménsula de trabajo

REF.NO.	CODE	Q'TY	ヒンメイ	NAME OF PARTS	RMKS
2	S02293001	1	オサエアク"カムサ"カネ	WORK CLAMP LIFTER CAM WASHER	
3-1	S02295000	1	オサエアク"ト"タイ	WORK CLAMP LIFTER BASE	
3-2	S02296001	1	ソレノイト"タイ	SOLENOID BASE	
3-3	110201001	2	シメネジ"6.35	SCREW 6.35	
3-4	S02298001	1	ソレノイト"レハ"ーシ"ク	SOLENOID LEVER SHAFT	
3-5	S02299100	1	オサエアク"カムレハ"ー	WORK CLAMP LIFTER CAM LEVER	
3-6	014760622	1	アナトメネジ"5.95	SET SCREW 5.95	
3-7	S02301001	1	オサエアク"コロ	WORK CLAMP LIFTER ROLLER	
3-8	152753001	1	オクリカムコロシ"ク	FEED CAM ROLLER SHAFT	
3-9	S02302001	1	オサエアク"カンサ"	WORK CLAMP LIFTER SPACER	
3-10	014760622	1	アナトメネジ"5.95	SET SCREW 5.95	
3-11	153043001	1	オクリカムコロシ"ク"クミ	FEED CAM ROLLER SHAFT ASSY	
3-12	014760622	1	アナトメネジ"5.95	SET SCREW 5.95	
3-13	048060342	1	トメフE6	STOP RING E6	
3-14	110367001	1	サ"カ"ネ	WASHER	
3-15	154596000	2	イトキリカムレハ"ークツシヨ	CUSHION	
3-16	154594000	1	カラ	COLLAR	
3-17	S02303001	1	カムレハ"ーリフトハ"ネ	SPRING	
3-18	154595001	1	カムレハ"ーモト"シハ"ネ	SPRING	
3-19	025770232	2	ヒラサ"カ"ネチユウ6.35	PLAIN WASHER 6.35	
3-20	028770242	2	ハ"ネサ"カ"ネ2-6.35	SPRING WASHER 2-6.35	
3-21	047201042	1	スプリング"ピン"AW2	SPRING PIN AW2	
4	154599000	1	ソレノイト"クツシヨ	SOLENOID CUSHION	
5	154600001	1	ソレノイト"レハ"ー	SOLENOID LEVER	
6	014680622	1	アナトメネジ"4.37クホ"ミ	SET SCREW 4.37	
7	018082022	2	アナボ"ルト"8X20	BOLT 8X20	
8	025080232	2	ヒラサ"カ"ネチユウ8	PLAIN WASHER 8	
9	S08461001	1	オサエアク"レハ"ーB	PRESSER BAR LIFTER LEVER (B)	
10	150756009	1	メクラセン	OIL CAP	
11	S02307001	1	オサエアク"レハ"ーシ"ク	WORK CLAMP LIFTER LEVER SHAFT	
12	110505001	2	サ"カ"ネ	WASHER	
13	048080342	1	トメフE8	STOP RING E8	
14	014760622	1	アナトメネジ"5.95	SET SCREW 5.95	
15	S15147101	1	オサエアク"レハ"ーハ"ネ	SPRING	
16-1	S02309000	1	ウワイトユルメレハ"ー	TENSION RELEASE LEVER	
16-2	S02310001	1	イトユルメサト"ウヒ"ン	PIN	
17	014760622	2	アナトメネジ"5.95	SET SCREW 5.95	
18	S02311001	1	ウワイトユルメホ"ウ	TENSION RELEASE BAR	
19	048040342	1	トメフE4	STOP RING E4	
22	159119101	1	チヨフセツネシ"クミ	ADJUST SCREW ASSY	
23	021910302	1	ナツト3シユ12.70	NUT 12.70	
24	S02318001	1	UUDオクリレンカン	UD LIFTING FEED CONNECTING ROD	
25	S02320001	1	カンケツオクリウテ"R	INTERMITTENT FEED ARM (R)	
26	062711612	1	ナヘ"コ476-32X16	SCREW 476X16	
27	150460001	1	U-UDオクリレハ"ーシ"ク	U-UD FEED LIFTER LEVER SHAFT	
28	150461001	1	オクリコロ	FEED ROLLER	
29	107453001	2	サ"カ"ネ	WASHER	
30	021750102	1	1シユナツト556-32	NUT 5.56	
31	S02313001	1	カンケツオクリシ"ク	INTERMITTENT FEED SHAFT	
32	S02321001	1	カムシ"クメタルR	CAM SHAFT BUSH (R)	
33	S02322001	1	カムシ"クメタルL	CAM SHAFT BUSH (L)	
34	014760622	2	アナトメネジ"5.95	SET SCREW 5.95	
35	S02319001	1	カンケツオクリウテ"L	INTERMITTENT FEED ARM (L)	
36	062751612	1	ナヘ"コ556-32X16	SCREW 556X16	
37	S02323001	1	リンクL	LINK (L)	
38	150451001	2	タ"ンネシ"6.35	STUD SCREW 6.35	
39	S02324001	1	カンケツレハ"ー	INTERMITTENT LEVER	
40	S02858001	1	オサエホ"ウダ"キクミ	PRESSER BAR CLAMP ASSY	
40-1	062681212	1	ナヘ"コ437-40X12	SCREW 4.37X12	
41	150467001	1	コロシ"ク	ROLLER SHAFT	
42	150468001	1	U-UDオクリレハ"ーコロ	U-UD FEED LIFTER LEVER ROLLER	
43	S02326001	1	カンケツアンナイ	INTERMITTENT GUIDE	

E. 押工上ゲ関係 / Work clamp lifter mechanism / Stoffhalterhebevorrichtung /
 Mécanisme de levreur du pinceur / Mecanismo del levantador de ménsula de trabajo

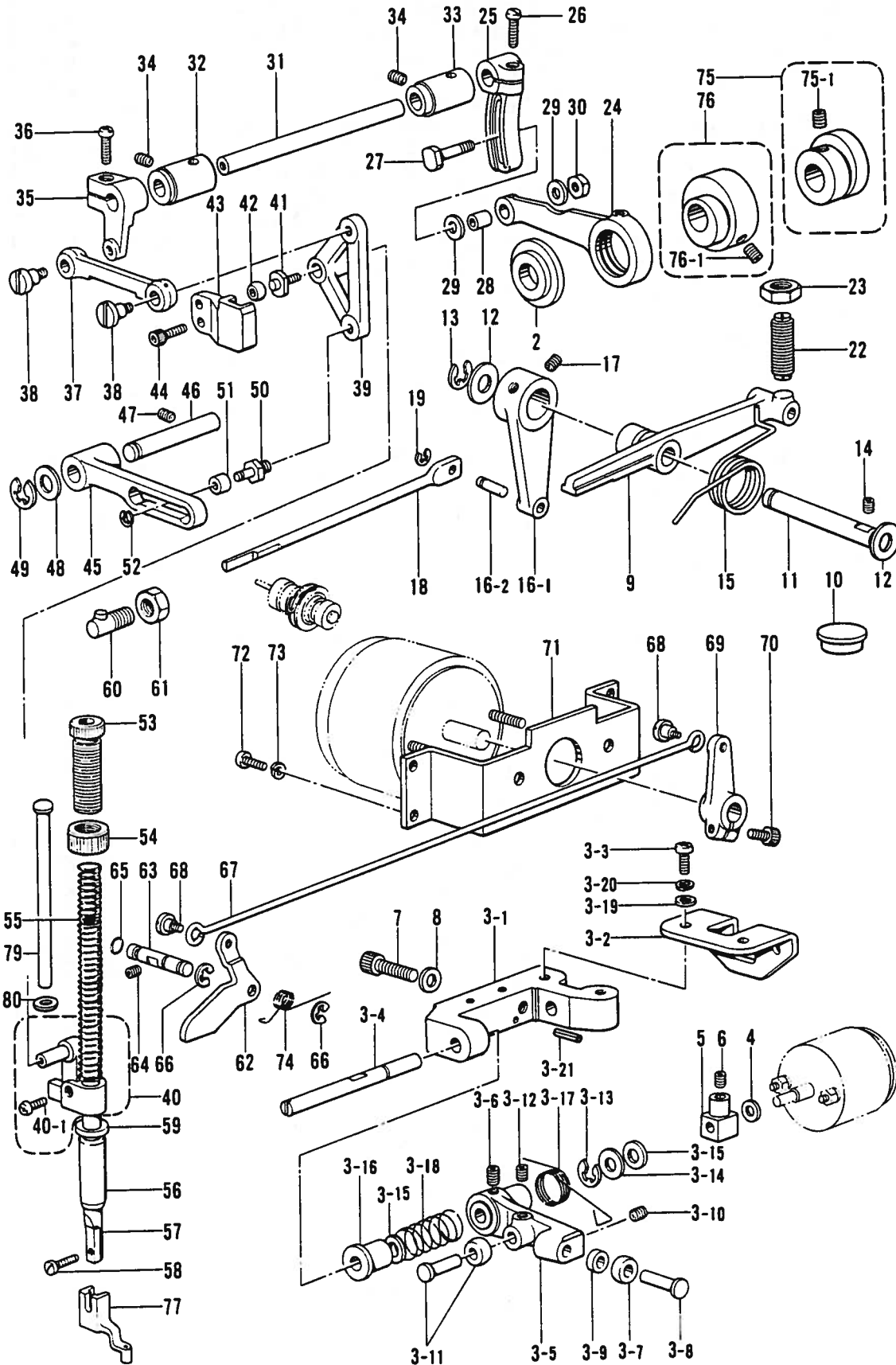

E. 押工上げ関係/Work clamp lifter mechanism/Stoffhalterhebevorrichtung/
 Mécanisme de levreur du pinceur/Mecanismo del levantador de ménsula de trabajo

REF. NO.	CODE	Q'TY	ヒンメイ	NAME OF PARTS	RMKS
44	018401222	2	アナボ"ルト4X12	BOLT 4X12	
45	S02327001	1	カンケツササエ	INTERMITTENT SUPPORT	
46	S02328001	1	カンケツササエシ"ク	INTERMITTENT SUPPORT SHAFT	
47	014760622	1	アトメネシ"5.95	SET SCREW 5.95	
48	142628001	1	スイハイオクリクランクリング"	FEED ROCK CRANK RING	
49	048080342	1	トメフE8	STOP RING E8	
50	S02329001	1	コロシ"ク	ROLLER SHAFT	
51	150461001	1	オクリコロ	FEED ROLLER	
52	048040342	1	トメフE4	STOP RING E4	
53	S31012001	1	オサエチヨウセツネシ"	PRESSER ADJUST SCREW	
54	S31013001	1	チヨウセツネシ"ツマミナツト	NUT	
55	S33179001	1	オサエハ"ネ	SPRING	
56	145472001	1	オサエホ"ウメタル	PRESSER BAR BUSH	
57	111466101	1	オサエホ"ウ	PRESSER BAR	
58	S13399001	1	シメネシ"3.57X12	SCREW 3.57X12	
59	S02333100	1	カンケツストツハ"L	STOPPER (L)	
60	S02300001	1	カンケツストツハ"ササエクミ	STOPPING SUPPORT ASSY	
61	021860312	1	ナツト3シユ9.52	NUT 9.52	
62	S02336001	1	カンケツオサエレハ"ー	INTERMITTENT PRESSER LEVER	
63	S02447001	1	カンケツオサエアケ"シ"ク	WORK CLAMP LIFTER SHAFT	
64	151603002	1	トメネシ"4.37	SET SCREW 4.37	
65	081001670	1	Oリング"PW1	O RING PW1	
66	048040342	2	トメフE4	STOP RING E4	
67	S02337001	1	オサエアケ"レンカン	WORK CLAMP LIFTER CONNECTING ROD	
68	145478001	2	タ"ンネシ"4.76	STUD SCREW 4.76	
69	S02338001	1	オサエアケ"RSレハ"ー	WORK CLAMP LIFTER (RS) LEVER	
70	018501622	1	アナボ"ルト5X16	BOLT 5X16	
71	S02339001	1	ロータリー-S"タイ	ROTARY (S) BASE	
72	062711212	4	ナヘ"コ476-32X12	SCREW 4.76X12	
73	028050242	4	ハ"ネサ"カ"ネ2-5	SPRING WASHER 2-5	
74	S02485001	1	カンケツオサエレハ"ーハ"ネ	SPRING	
75	S16030001	1	オサエアケ"カムA"クミ	WORK CLAMP LIFTER CAM ASSY (A)	
75-1	014770622	2	アトメネシ"6.35クホ"ミ	SET SCREW 6.35	
76	S16254001	1	オサエアケ"カムB"クミ	WORK CLAMP LEFTER CAM ASSY (B)	
76-1	014770622	2	アトメネシ"6.35クホ"ミ	SET SCREW 6.35	
77	152283101	1	オサエアシA	PRESSER FOOT (A)	
79	S10112001	1	オサエハ"ネアンナイ	SPRING GUIDE	
80	S03677001	1	サ"カ"ネ	WASHER	

F. 駆動側・送り関係 / Feed guide mechanism / Transportführung /
 Mécanisme du guide de l'entraînement / Mecanismo de la guía de alimentación

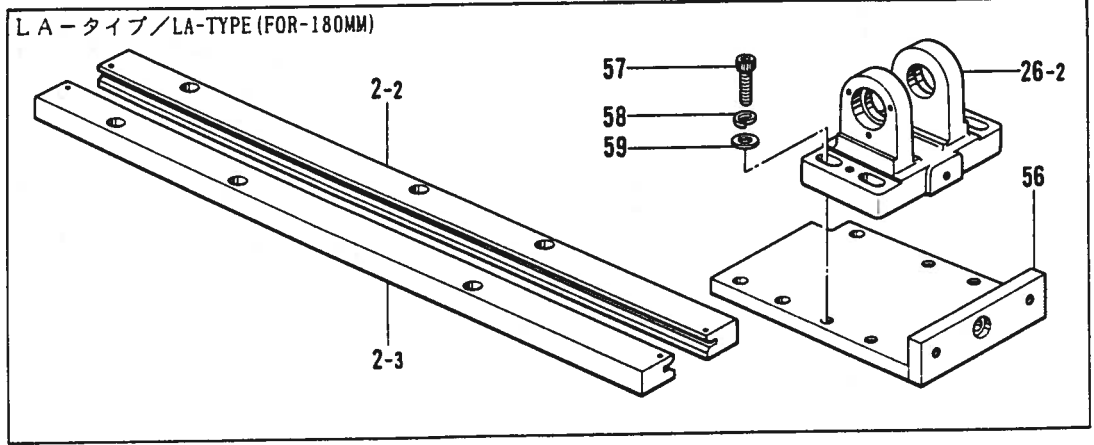
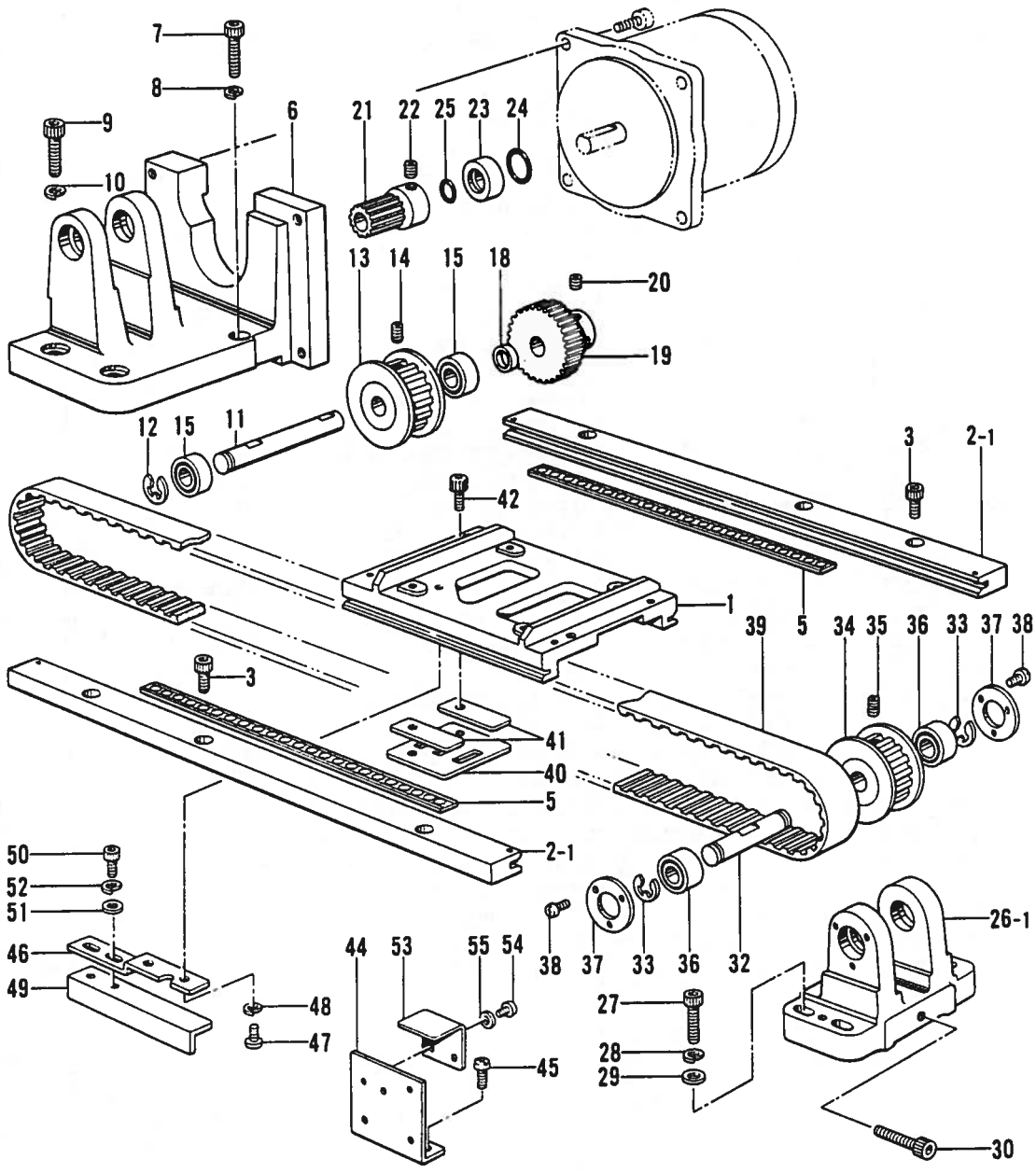

F. 駆動側・送り関係/Feed guide mechanism/Transportführung/
Mécanisme du guide de l'entraînement/Mecanismo de la guía de alimentación

REF.NO.	CODE	Q'TY	ヒンメイ	NAME OF PARTS	RMKS
1	S02408101	1	オクリタ"イX	X-FEED BRACKET	
2-1	S07787001	2	Xオクリアンナイクミ150	X-FEED GUIDE ASSY (150)	
3	018681022	6	アナホ"ルト4.37X10	BOLT 4.37X10	
5	S07789100	2	Xリテーナクミ150	X-RETAINER ASSY (150)	
6	S07791000	1	Pモータータ"イ150	P-MOTOR BASE (150)	
7	018502222	1	アナホ"ルト5X22	BOLT 5X22	
8	028050242	1	ハ"ネサ"カ"ネ2-5	SPRING WASHER 2-5	
9	018062022	2	アナホ"ルト6X20	BOLT 6X20	
10	028060242	2	ハ"ネサ"カ"ネ2-6	SPRING WASHER 2-6	
11	S02413001	1	T"ヘルトシ"クD	TIMING BELT SHAFT (D)	
12	048060342	1	トメフE6	STOP RING E6	
13	S02468001	1	タイミンク"プーリ	TIMING PULLEY	
14	014760622	2	アナトメネシ"5.95	SET SCREW 5.95	
15	072068980	2	タマシ"クウケ689ZZ	BALL BEARING 689ZZ	
18	S02474001	1	シ"クウケカラ"ーS	BEARING COLLAR (S)	
19	S02414001	1	アイト"ルキ"ヤ	IDLE GEAR	
20	014760622	2	アナトメネシ"5.95	SET SCREW 5.95	
21	S02403001	1	クト"ウキ"ヤ	ACTUATING GEAR	
22	014760622	2	アナトメネシ"5.95	SET SCREW 5.95	
23	S02404001	1	O"リング"ホルダ"	O RING HOLDER	
24	081014070	1	O"リング"P14	O RING P14	
25	081007670	1	O"リング"PW7	O RING PW7	
26-1	S07792000	1	プーリタ"イ150	PULLEY BASE (150)	
27	018502222	3	アナホ"ルト5X22	BOLT 5X22	
28	028050242	3	ハ"ネサ"カ"ネ2-5	SPRING WASHER 2-5	
29	025050232	3	ヒラサ"カ"ネチユウ-5	PLAIN WASHER 5	
30	018502522	1	アナホ"ルト5X25	BOLT 5X25	
32	S02416001	1	T"ヘルトシ"クU	TIMING BELT SHAFT (U)	
33	048060342	2	トメフE6	STOP RING E6	
34	S02468001	1	タイミンク"プーリ	TIMING PULLEY	
35	014760622	2	アナトメネシ"5.95	SET SCREW 5.95	
36	072068980	2	タマシ"クウケ689ZZ	BALL BEARING 689ZZ	
37	S02476001	2	シ"クウケフタ	BEARING COVER	
38	062300806	6	ナヘ"コ3X8	SCREW M3X8	
39	S07793000	1	タイミンク"ヘルト150	TIMING BELT (150)	
40	S02417001	1	ヘルトホルタ"D	BELT HOLDER (D)	
41	S02418001	2	ヘルトホルタ"U	BELT HOLDER (U)	
42	018681022	2	アナホ"ルト4.37X10	BOLT 4.37X10	
44	S02419001	1	Xキハ"ンタ"イ	X-CIRCUIT BOARD BASE	
45	062711012	2	ナヘ"コ476-32X10	SCREW 4.76X10	
46	S02420001	1	Xケ"ンテンダ"イ	X-AXIS HOME POSITION BASE	
47	062680812	2	ナヘ"コ437-40X8	SCREW 4.37X8	
48	028680242	2	ハ"ネサ"カ"ネ2-4.37	SPRING WASHER 2-4.37	
49	S07794001	1	Xケ"ンテント"ク"150	X-AXIS HOME POSITION DOG 150	
50	018400632	2	アナホ"ルト4X6	BOLT 4X6	
51	025040232	2	ヒラサ"カ"ネチユウ4	PLAIN WASHER 4	
52	028040242	2	ハ"ネサ"カ"ネ2-4	SPRING WASHER 2-4	
53	S02255001	1	Xケ"ンテンカハ"ー	X-AXIS HOME POSITION COVER	
54	062300416	2	ナヘ"コM3X4	SCREW M3X4	
55	025030232	2	ヒラサ"カ"ネチユウ3	PLAIN WASHER 3	
<LA-タイプ (180MM)/LA-TYPE (180MM)>					
2-2	S10674001	1	Xオクリアンナイクミ180B	X-FEED GUIDE ASSY (180)	
2-3	S10676001	1	Xオクリアンナイクミ180F	X-FEED GUIDE ASSY (180F)	
5	S10678100	2	Xリテーナクミ180	X-RETAINER ASSY (180)	
26-2	S10672001	1	プーリタ"イ180	PULLEY BASE (180)	
39	S10673000	1	タイミンク"ヘルト180	TIMING BELT (180)	
56	S10671001	1	プーリ"タ"イ180	PULLEY BASE (180)	
57	018501622	4	アナホ"ルト5X16	BOLT 5X16	
58	028050242	4	ハ"ネサ"カ"ネ2-5	SPRING WASHER 2-5	
59	025050232	4	ヒラサ"カ"ネチユウ-5	PLAIN WASHER 5	

G. 下軸関係/ Lower shaft mechanism/ Untere Welle/
 Mécanisme de l'arbre inférieur/ Mecanismo del eje inferior

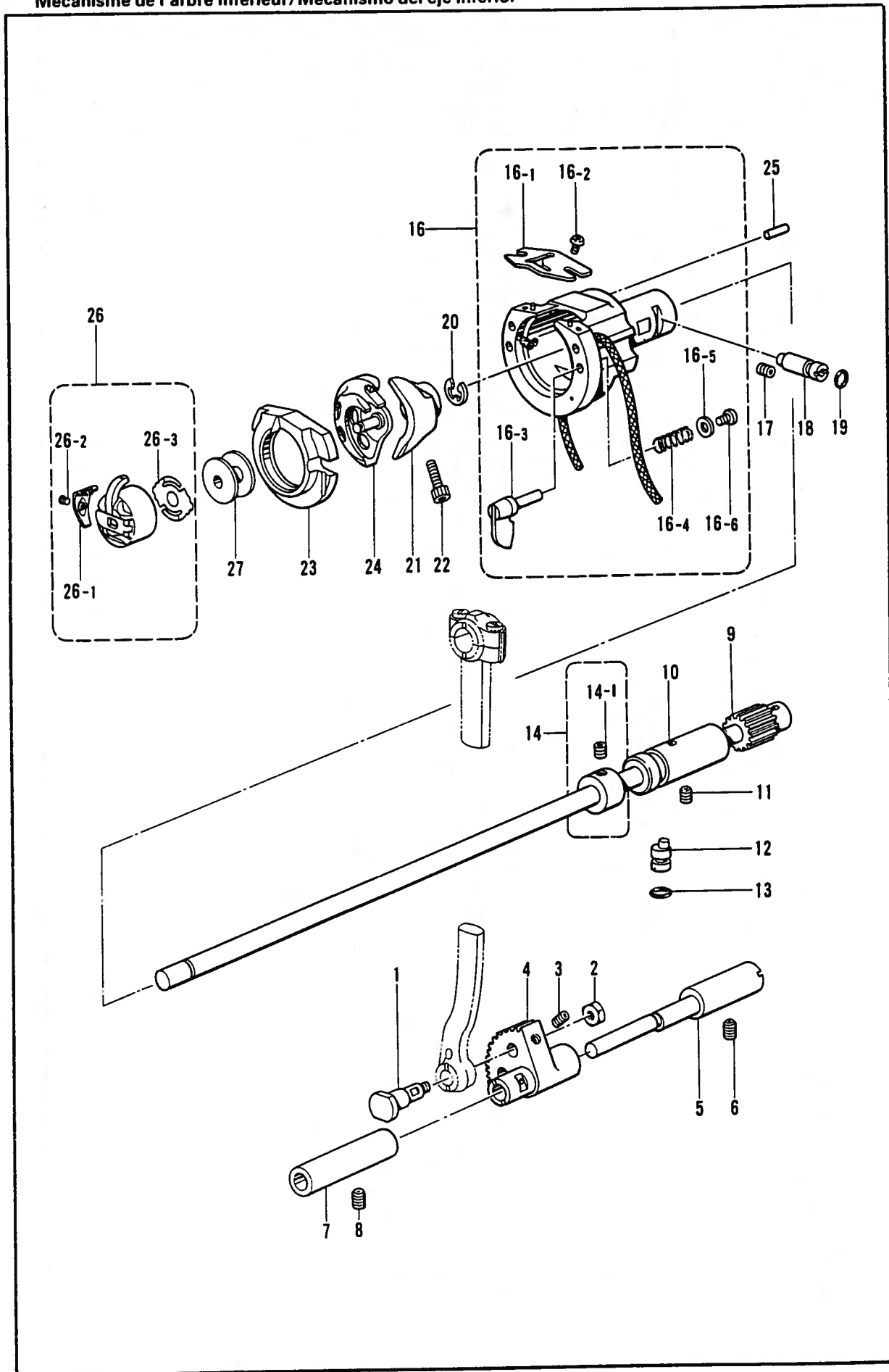

G. 下軸関係/Lower shaft mechanism/Untere Welle/
 Mécanisme de l'arbre inférieur/Mecanismo del eje inferior

REF NO.	CODE	Q'TY	品名	NAME OF PARTS	RMKS
1	141786001	1	クランクロッド"タ"ネジ	CRANK ROD STUD SCREW	
2	104689002	1	ナット7.14	NUT 7.14	
3	014680622	1	アナトメネジ"4.37クホ"ミ	SET SCREW 4.37	
4	152245001	1	ヨウト"ウキ"ヤ	ROCK GEAR	
5	S02422001	1	ヨウト"ウキ"ヤ-シ"ク	ROCK GEAR SHAFT	
6	014760622	1	アナトメネジ"5.95	SET SCREW 5.95	
7	152247001	1	ヨウト"ウシ"クメタル	ROCK SHAFT BUSH	
8	014760622	1	アナトメネジ"5.95	SET SCREW 5.95	
9	S02423101	1	シタジ"ククミ	LOWER SHAFT ASSY	
10	S02425001	1	シタジ"クメタル	LOWER SHAFT BUSH	
11	014760622	1	アナトメネジ"5.95	SET SCREW 5.95	
12	S02426001	1	ト"ライハ"ーチヨウセツシ"ク	DRIVER ADJUST STUD	
13	081003670	1	Oリング"PW3	O RING PW3	
14	S03704001	1	セツトカラークミ	SET COLLAR ASSY	
14-1	014770622	2	アナトメネジ"6.35クホ"ミ	SET SCREW 6.35	
16	S02427101	1	オオカマタイクミ	SHUTTLE RACE BASE ASSY	
16-1	S02429001	1	カマイトアンナイ	SHUTTLE RACE THREAD GUIDE	
16-2	062660412	2	ナヘ"ユ318-40X4	SCREW 318X4	
16-3	152683001	2	オオカマトリツケツメ	LARGE SHUTTLE	
16-4	152684101	2	オオカマトリツケハ"ネ	SPRING	
16-5	402887001	2	サ"ガ"ネ	WASHER	
16-6	062660712	2	ナヘ"ユ318-40X7	SCREW 318X7	
17	014760622	1	アナトメネジ"5.95	SET SCREW 5.95	
18	152678001	1	カマチヨウセツシ"ク	SHUTTLE HOOK ADJUST STUD	
19	081003670	1	Oリング"PW3	O RING PW3	
20	048080342	1	トメフE8	STOP RING E8	
21	152681201	1	ト"ライハ"ー	DRIVER	
22	018501422	1	アナボ"ルト5X14	BOLT 5X14	
23	152686001	1	オオカマB	LARGE SHUTTLE HOOK (B)	
24	S15663001	1	ナカカマLB	INNER ROTARY HOOK (LB)	
25	141808001	1	オオカマアンナイピン	PIN	
26	S15902101	1	ホ"ビ"ンケースクミLA	BOBBIN CASE ASSY (LA)	
26-1	S16074001	1	ケースチヨウシハ"ネA	SPRING (A)	
26-2	S16492001	1	ホ"ビ"ンケースハ"ネネジ"	SCREW	
26-3	S15667001	1	クウテンホ"ウシハ"ネ	BOBBIN TENSION SPRING	
27	S15665001	1	ホ"ビ"ンLA	BOBBIN (LA)	

H. 給油・潤滑関係 / Lubrication / Schmierung /
Lubrification / Lubricación

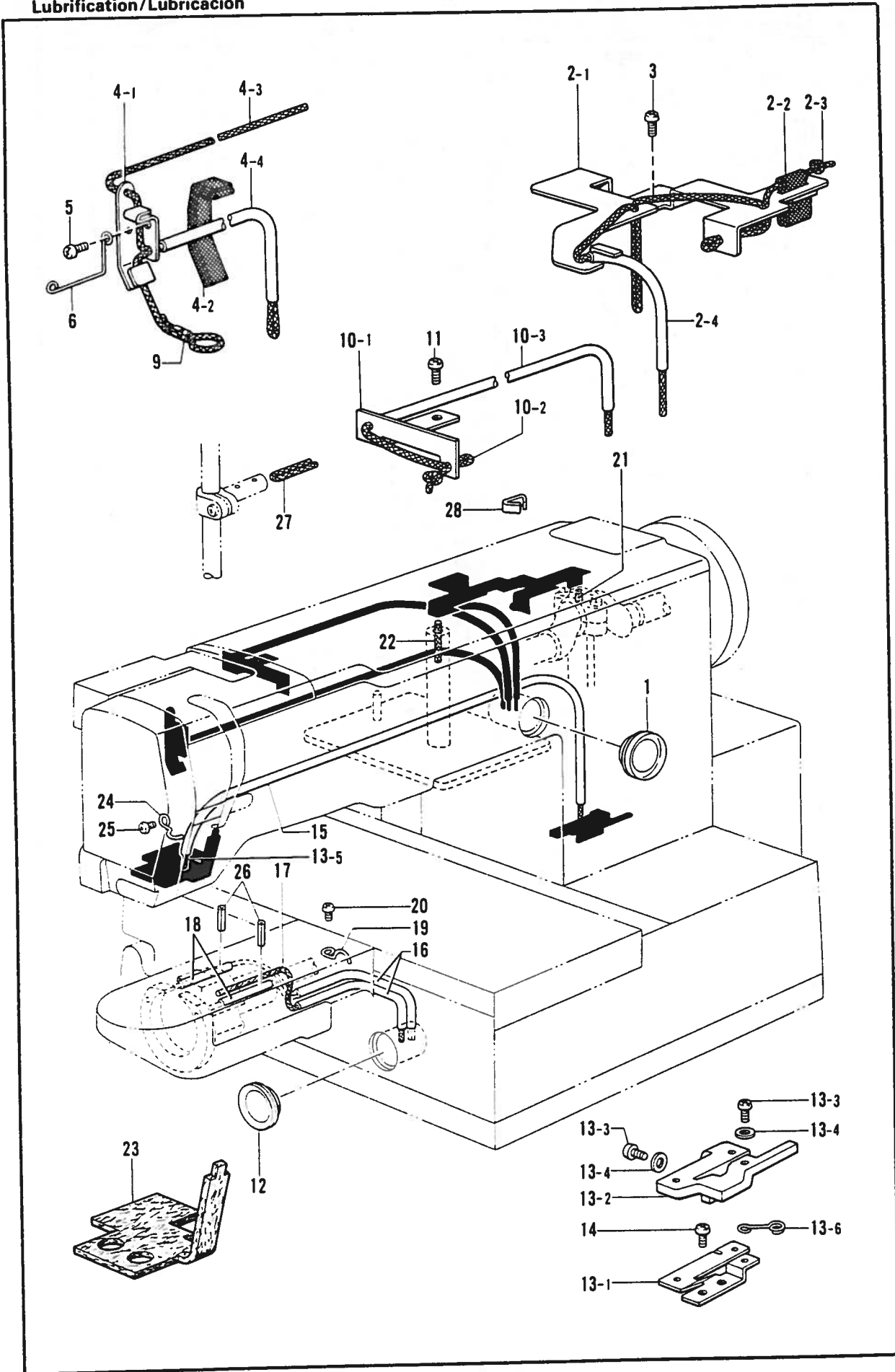

H. 給油・潤滑関係/Lubrication/Schmierung/
Lubrification/Lubrificación

REF NO.	CODE	Q'TY	品名	NAME OF PARTS	RMKS
1	152948001	1	オイルホ"ットマト"	OIL GAUGE WINDOW	
2-1	S02459001	1	ウツシ"クキユウユササエイタ	WICK SUPPORT PLATE	
2-2	152952001	1	ロツト"キユウユフエルト	FELT	
2-3	S02962001	1	クミヒモ6X6(L=550)	WICK 6X6 (L=550)	
2-4	S03662000	1	ヒ"ニルチューブ"	OIL TUBE	
3	062680812	2	ナヘ"コ437-40X8	SCREW 4.37X8	
4-1	S21527001	1	デンヒ"ンキユウユササエ	WICK SUPPORT	
4-2	152955001	1	ヒラクミヒモ(L=210)	FLAT WICK (L=210)	
4-3	S02857001	1	クミヒモ4X4(L=1200)	WICK 4X4 (L=1200)	
4-4	S03661000	1	ヒ"ニルチューブ"	OIL TUBE	
5	062680612	1	ナヘ"コ4.37-40X6	SCREW 4.37X6	
6	S02239001	1	ハリホ"ウヒモササエ	WICK SUPPORT	
9	104567001	1	クミヒモササエ	WICK SUPPORT	
10-1	S02462001	1	オサエコロキユウユササエイタ	WICK SUPPORT PLATE	
10-2	S02962001	1	クミヒモ6X6(L=550)	WICK 6X6 (L=550)	
10-3	146375000	1	ヒ"ニルチューブ"	OIL TUBE	
11	062680812	2	ナヘ"コ437-40X8	SCREW 4.37X8	
12	152948001	1	オイルホ"ットマト"	OIL GAUGE WINDOW	
13-1	S02464001	1	シタシ"クキユウユササエイタ	FELT SUPPORT PLATE	
13-2	S02465000	1	シタシ"クキユウユフエルト	FELT	
13-3	062670612	4	ナヘ"コ357-40X6	SCREW 3.57X6	
13-4	025350332	4	ヒラサ"カ"ネタ"イ3.5	PLAIN WASHER 3.5	
13-5	152963001	1	クミヒモ4X4(L=600)	WICK 4X4 (L=600)	
13-6	S02976001	1	キユウユフエルトササエ	FELT SUPPORT	
14	062680812	2	ナヘ"コ437-40X8	SCREW 4.37X8	
15	146373000	1	ヒ"ニルチューブ"	OIL TUBE	
16	142329000	2	ヒ"ニルチューブ"	OIL TUBE	
17	152963001	1	クミヒモ4X4(L=600)	WICK 4X4 (L=600)	
18	112669001	2	ヒ"ニルチューブ"	OIL TUBE	
19	152969001	1	コート"ササエカネ	CORD SUPPORT	
20	062670612	1	ナヘ"コ357-40X6	SCREW 3.57X6	
21	107149001	1	フエルト	FELT	
22	155489000	1	クミヒモ(L=270)	WICK (L=270)	
23	S02466100	1	スイアケ"フエルト	FELT	
24	152969001	1	コート"ササエカネ	CORD SUPPORT	
25	062670612	1	ナヘ"コ357-40X6	SCREW 3.57X6	
26	047251640	2	スプリング"ヒ"ンAW2.5	SPRING PIN AW2.5	
27	S03289001	1	クミヒモ4X4(L=40)	WICK 4X4 (L=40)	
28	S07469001	3	チューブ"カシメ	TUBE CALKING	

J. 糸通シ関係/Threading mechanism/Fadenführungs-vorrichtung/
 Mécanisme de l'enfilage/Mecanismo del enhebrado

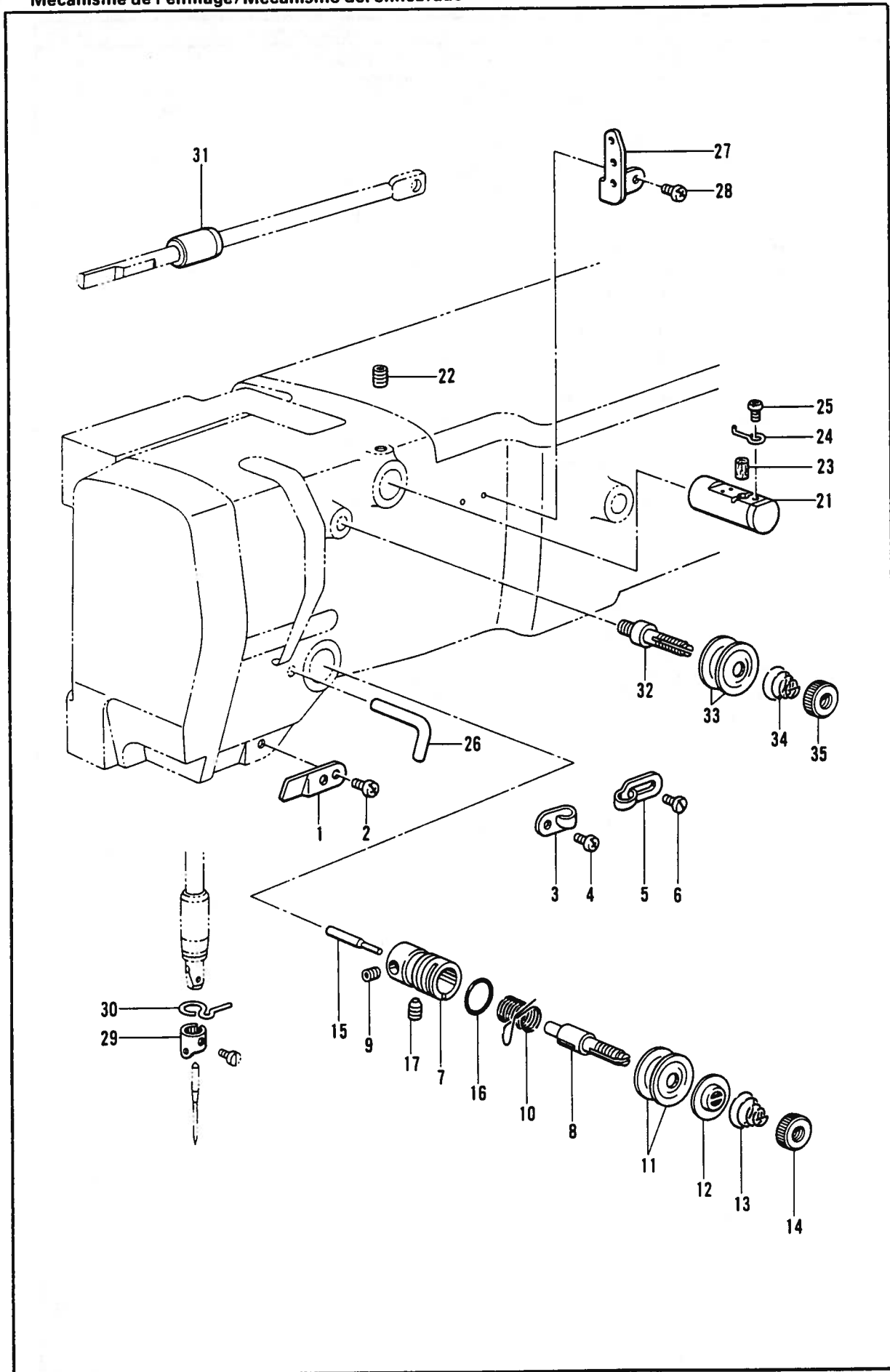

J. 糸通シ関係/Threading mechanism/Fadenführungsrichtung/
Mécanisme de l'enfilage/Mecanismo del enhebrado

REF. NO.	CODE	Q'TY	ヒンメイ	NAME OF PARTS	RMKS
1	152869001	1	アームイトミチ	ARM THREAD GUIDE	
2	062711012	1	ナヘ"コ476-32X10	SCREW 4.76X10	
3	152870001	1	アームイトカケ	ARM THREAD GUIDE	
4	062670612	1	ナヘ"コ357-40X6	SCREW 3.57X6	
5	113316001	1	アームイトアンナイ	ARM THREAD GUIDE	
6	112751003	1	シメネジ"3.57	SCREW 3.57	
7	S02434001	1	イトチヨウシダ"イ	TENSION BRACKET	
8	S02435001	1	イトチヨウシホ"ウ	TENSION STUD	
9	013679412	1	トメネジ"3.57クホ"ミ	SET SCREW 3.57	
10	144588001	1	イトトリハ"ネB	SPRING (B)	
11	145446001	2	イトチヨウシサラ	TENSION DISC	
12	159805001	1	イトチヨウシサラオサエ	TENSION DISC PRESSER	
13	107606001	1	イトチヨウシハ"ネ	TENSION SPRING	
14	100136001	1	イトチヨウシナツト	TENSION NUT	
15	S02436001	1	イトユルメシ"ク	TENSION RELEASE SHAFT	
16	114294001	1	O"リング"	O RING	
17	014760622	1	アナトメネジ"5.95	SET SCREW 5.95	
21	152881001	1	エキレイタイク"ミ	NEEDLE COOLER ASSY	
22	013760612	1	トメネジ"5.95クホ"ミ	SET SCREW 5.95	
23	152883000	1	フェルト8X15.5	FELT 8X15.5	
24	152884001	1	エキレイイトカケ	NEEDLE COOLER THREAD GUIDE	
25	062670412	1	ナヘ"コ357-40X4	SCREW 3.57X4	
26	159224001	1	アームイトカケ	ARM THREAD GUIDE	
27	152889001	1	ミツメイトカケ	THREAD RETAINER	
28	062670612	2	ナヘ"コ357-40X6	SCREW 3.57X6	
29	S02438001	1	ハリホ"ウイトアンナイA	NEEDLE BAR THREAD GUIDE (A)	
30	152891001	1	ハリホ"ウメタルDイトアンナイ	NEEDLE BAR BUSH (D) THREAD GUIDE	
31	S02457001	1	ユルメホ"ウメタル	RELEASE STUD BUSH	
32	115186001	1	シユイトチヨウシホ"ウ	MAIN THREAD TENSION STUD	
33	145446001	2	イトチヨウシサラ	TENSION DISC	
34	115188001	1	シユイトチヨウシハ"ネ	TENSION SPRING	
35	100136001	1	イトチヨウシナツト	TENSION NUT	

K. 糸巻関係/Bobbin winder mechanism/Spuler/
 Mécanisme du bobineur/Mecanismo del devanador de la canilla

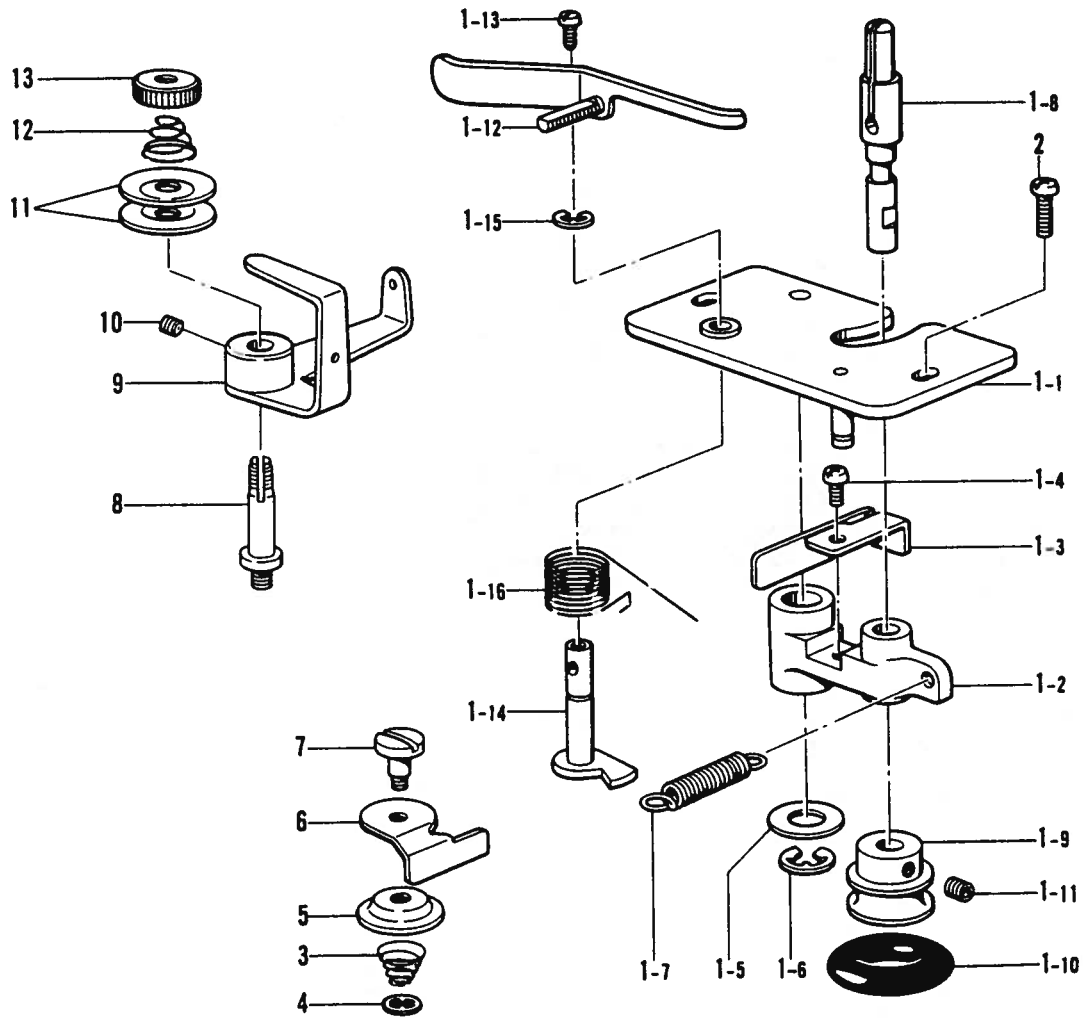

K. 糸巻関係/Bobbin winder mechanism/Spuler/
 Mécanisme du bobineur/Mecanismo del devanador de la canilla

REF. NO.	CODE	Q'TY	ヒンメイ	NAME OF PARTS	RMKS
1	S02448003	1	イトマキクミ	BOBBIN WINDER ASSY	
1-1	S01288003	1	イトマキト"ク"イクミ	BOBBIN WINDER BRACKET ASSY	
1-2	S02449001	1	イトマキウテ"	BOBBIN WINDER ARM	
1-3	S01292001	1	イトマキイタハ"ネ	PLATE SPRING	
1-4	062680812	1	ナヘ"コ437-40X8	SCREW 4.37X8	
1-5	025080132	1	ヒラサ"カ"ネシヨウ8	PLAIN WASHER 8	
1-6	048060342	1	トメフE6	STOP RING E6	
1-7	S01294001	1	イトマキウテ"ハ"ネ	SPRING	
1-8	S02450001	1	イトマキジ"ク	BOBBIN WINDER SHAFT	
1-9	154528001	1	イトマキクルマ	BOBBIN WINDER WHEEL	
1-10	120448001	1	ゴムウ	RUBBER RING	
1-11	014680622	2	アナトメネシ"4.37クホ"ミ	SET SCREW 4.37	
1-12	159253001	1	ホ"ヒ"ンオサエ	BOBBIN PRESSER	
1-13	S01998001	1	アタマツキトメネシ"3.57	SET SCREW 3.57	
1-14	S01291001	1	イトマキカムシ"ク	THREAD WINDER CAM SHAFT	
1-15	048050342	1	トメフE5	STOP RING E5	
1-16	S01293001	1	イトマキカムシ"クハ"ネ	SPRING	
2	062711012	2	ナヘ"コ476-32X10	SCREW 4.76X10	
3	144505000	1	イトアンナイハ"ネ	SPRING	
4	146200001	1	トメフCS4	STOP RING CS4	
5	146199001	1	イトツカミサラ	THREAD CLAMP DISC	
6	146198001	1	イトツカミメス	THREAD CLAMP KNIFE	
7	118764002	1	タ"ンネシ"4.37	STUD SCREW 4.37	
8	159256001	1	イトマキチヨウシホ"ウ	BOBBIN WINDER THREAD TENSION STUD	
9	S15150001	1	イトマキイトアンナイ	BOBBIN WINDER THREAD GUIDE	
10	014680622	1	アナトメネシ"4.37クホ"ミ	SET SCREW 4.37	
11	145446001	2	イトチヨウシサラ	TENSION DISC	
12	115188001	1	シユイトチヨウシハ"ネ	TENSION SPRING	
13	100136001	1	イトチヨウシナツト	TENSION NUT	

L. 糸切り関係/Thread trimmer mechanism/Fadenabschneidevorrichtung/
 Mécanisme de coupe-fil/Mecanismo de la cortadura de hilos

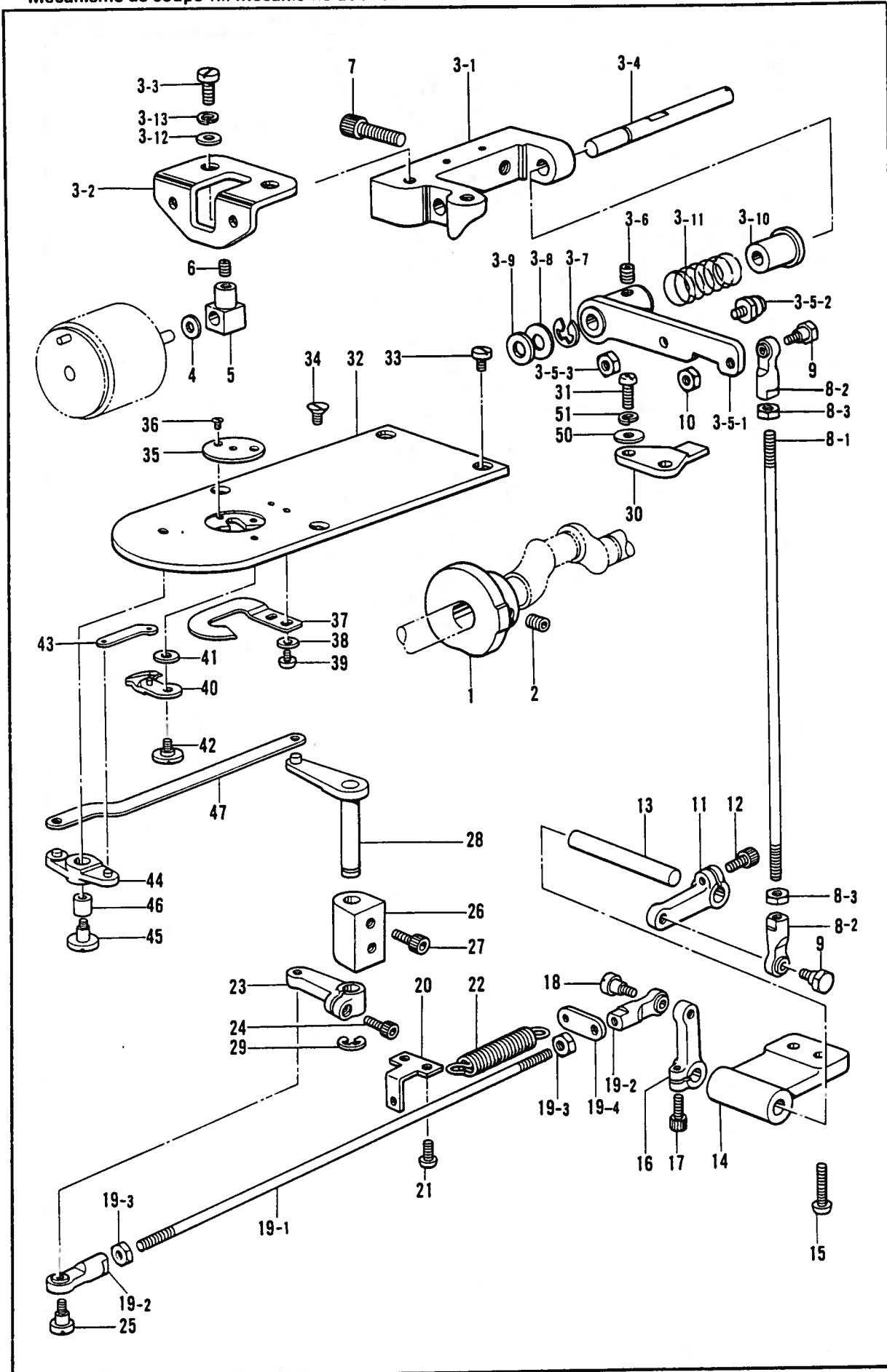

L. 糸切り関係/Thread trimmer mechanism/Fadenabschneidevorrichtung/
Mécanisme de coupe-fil/Mecanismo de la cortadura de hilos

REF.NO.	CODE	Q'TY	ヒンメイ	NAME OF PARTS	RMKS
1	S29695001	1	イトキリカム	THREAD TRIMMER CAM	
2	014770622	2	アナトメネシ"6.35クホ"ミ	SET SCREW 6.35	
3-1	S02348000	1	イトキリ"タイ	THREAD TRIMMER BRACKET	
3-2	S02296001	1	ソレノイト"タイ	SOLENOID BASE	
3-3	110201001	2	シメネシ"6.35	SCREW 6.35	
3-4	S02298001	1	ソレノイト"レハ"ーシ"ク	SOLENOID LEVER SHAFT	
3-5-1	S02350001	1	イトキリカムレハ"ー	KNIFE CAM LEVER	
3-5-2	154590001	1	コロシ"クCクミ	ROLLER SHAFT (C) ASSY	
3-5-3	105234003	1	ナツト4.37	NUT 4.37	
3-6	014770622	1	アナトメネシ"6.35クホ"ミ	SET SCREW 6.35	
3-7	048060342	1	トメフE6	STOP RING E6	
3-8	110367001	1	サ"カ"ネ	WASHER	
3-9	154596000	1	イトキリカムレハ"ークツシヨ	CUSHION	
3-10	154594000	1	カラ	COLLAR	
3-11	S02351001	1	カムレハ"ーモト"シハ"ネ	SPRING	
3-12	025770232	2	ヒラサ"カ"ネチユウ6.35	PLAIN WASHER 6.35	
3-13	028770242	2	ハ"ネサ"カ"ネ2-6.35	SPRING WASHER 2-6.35	
4	154599000	1	ソレノイト"クツシヨ	SOLENOID CUSHION	
5	154600001	1	ソレノイト"レハ"ー	SOLENOID LEVER	
6	014680622	1	アナトメネシ"4.37クホ"ミ	SET SCREW 4.37	
7	018082022	2	アナホ"ルト8X20	BOLT 8X20	
8	S02352001	1	イトキリロツト"クミA	CONNECTING ROD ASSY (A)	
8-1	S02353001	1	イトキリロツト"	CONNECTING ROD	
8-2	141492001	2	タマツキ"テクミ	JOINT ASSY	
8-3	150553001	2	ナツト5.95	NUT 5.95	
9	S02354001	2	タマツキ"テタ"ンネシ"B	STUD SCREW (B)	
10	150553001	1	ナツト5.95	NUT 5.95	
11	S02355001	1	イトキリサト"ウレハ"ー	THREAD TRIMMER LEVER	
12	018681022	1	アナホ"ルト4.37X10	BOLT 4.37X10	
13	S02356001	1	イトキリサト"ウシ"ク	THREAD TRIMMER SHAFT	
14	S02357000	1	イトキリシ"ク"タイ	THREAD TRIMMER SHAFT BASE	
15	062762012	2	ナヘ"コ595-28X20	SCREW 595X20	
16	S02355001	1	イトキリサト"ウレハ"ー	THREAD TRIMMER LEVER	
17	018681022	1	アナホ"ルト4.37X10	BOLT 4.37X10	
18	141494001	1	タマツキ"テタ"ンネシ"	STUD SCREW	
19	S02358001	1	イトキリロツト"クミB	CONNECTING ROD ASSY (B)	
19-1	S02353001	1	イトキリロツト"	CONNECTING ROD	
19-2	141492001	2	タマツキ"テクミ	JOINT ASSY	
19-3	150553001	2	ナツト5.95	NUT 5.95	
19-4	S02360001	1	イトキリハ"ネカケB	SPRING HOOK (B)	
20	S02361001	1	イトキリハ"ネカケA	SPRING HOOK (A)	
21	062761012	2	ナヘ"コ595-28X10	SCREW 595X10	
22	S02362001	1	イトキリハ"ネA	SPRING (A)	
23	S02355001	1	イトキリサト"ウレハ"ー	THREAD TRIMMER LEVER	
24	018681022	1	アナホ"ルト4.37X10	BOLT 4.37X10	
25	141494001	1	タマツキ"テタ"ンネシ"	STUD SCREW	
26	S02364000	1	イトキリレハ"ーシ"ク"タイ	THREAD TRIMMER LEVER SHAFT BASE	
27	018501022	2	アナホ"ルト5X10	BOLT 5X10	
28	S02365001	1	イトキリレハ"ーウエクミ	THREAD TRIMMER LEVER UPPER ASSY	
29	048050342	1	トメフE5	STOP RING E5	
30	S02368001	1	ストッパ"ー	STOPPER	
31	062761412	2	ナヘ"コ595-28X14	SCREW 595X14	
32	S02370001	1	ハリイタ	NEEDLE PLATE	
33	153208002	2	シメネシ"4.37	SCREW 4.37	
34	100032004	2	サラネシ"4.37	SCREW 4.37	
35	S02373001	1	ハリアナイタF	NEEDLE HOLE PLATE (F)	
36	100360003	2	サラネシ"2.38	SCREW 2.38	
37	S02374001	1	コテイハ	FIXED KNIFE	
38	025350132	2	ヒラサ"カ"ネシヨウ	PLAIN WASHER	
39	062670412	2	ナヘ"コ357-40X4	SCREW 3.57X4	
40	S02375001	1	イト"ウハクミ	MOVABLE KNIFE ASSY	
41	S02378001	1	イト"ウハサ"カ"ネT=0.6	WASHER T=0.6	

L. 糸切り関係 / Thread trimmer mechanism / Fadenabschneidevorrichtung /
 Mécanisme de coupe-fil / Mecanismo de la cortadura de hilos

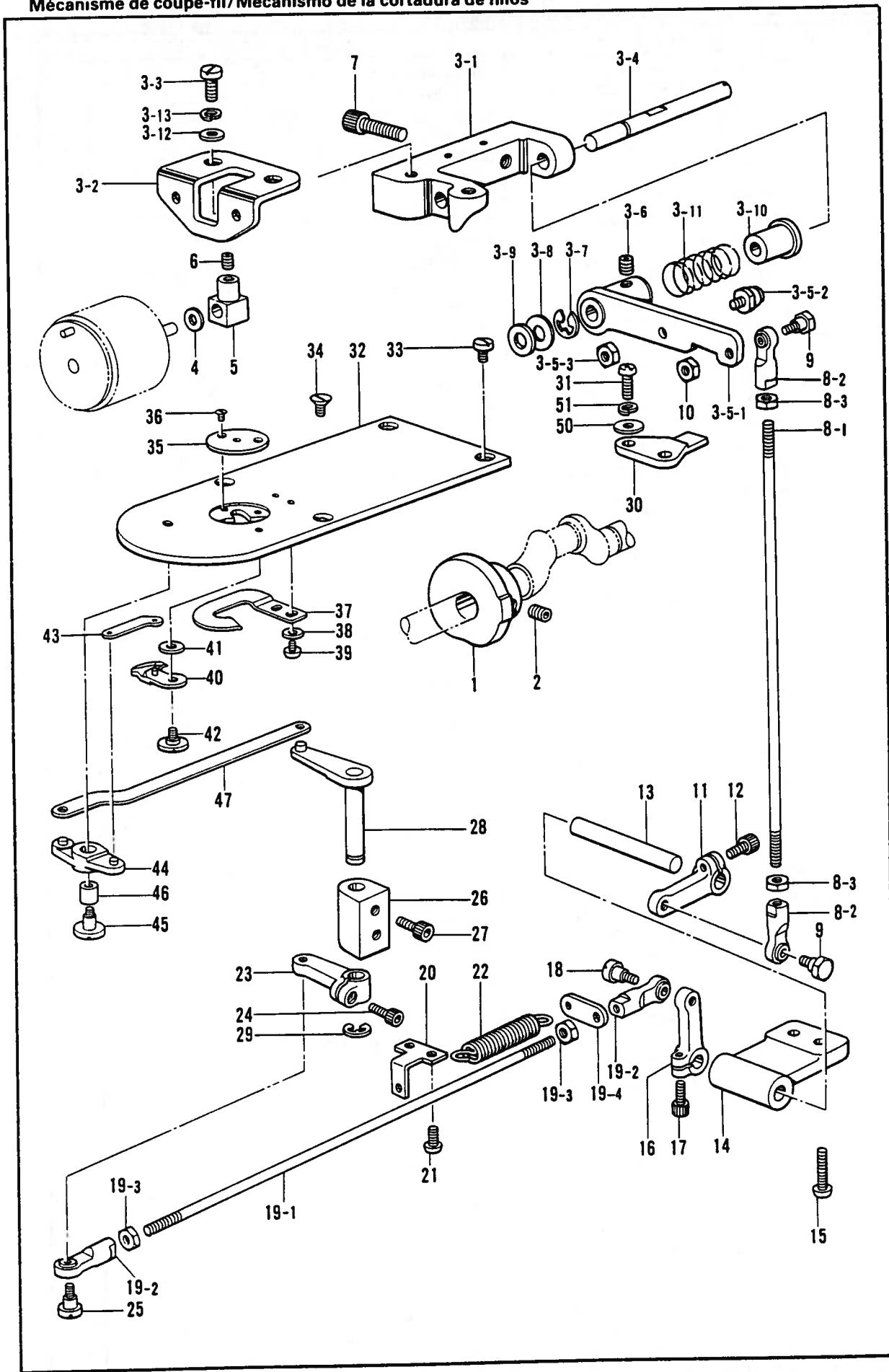

L. 糸切り関係/Thread trimmer mechanism/Fadenabschneidevorrichtung/
 Mécanisme de coupe-fil/Mecanismo de la cortadura de hilos

REF.NO.	CODE	Q'TY	ヒンメイ	NAME OF PARTS	RMKS
41	S02378002	1	イト"ウハサ"ガ"ネT=0.7	WASHER T=0.7	
41	S07854001	1	イト"ウハサ"ガ"ネT=0.8	WASHER T=0.8	
42	S02379001	1	タ"ンネシ"3.57	STUD SCREW 3.57	
43	S02380001	1	イト"ウハレンカン	MOVABLE KNIFE CONNECTING ROD	
44	S02381001	1	イトキリレンケツレバ"ークミ	CONNECTING LEVER ASSY	
45	S00722001	1	シメネシ"4.37	SCREW 4.37	
46	S00723001	1	カラ"7.94	COLLAR 7.94	
47	S02385001	1	イトキリレンカン	THREAD TRIMMER CONNECTING ROD	
50	025060232	2	ヒラサ"ガ"ネチユウ6	PLAIN WASHER 6	
51	028060242	2	ハ"ネサ"ガ"ネ2-6	SPRING WASHER 2-6	

M. ワイパー関係/Thread wiper mechanism/Fadenwischvorrichtung/
 Mécanisme de tire-fil/Mecanismo de limpiador de hilos

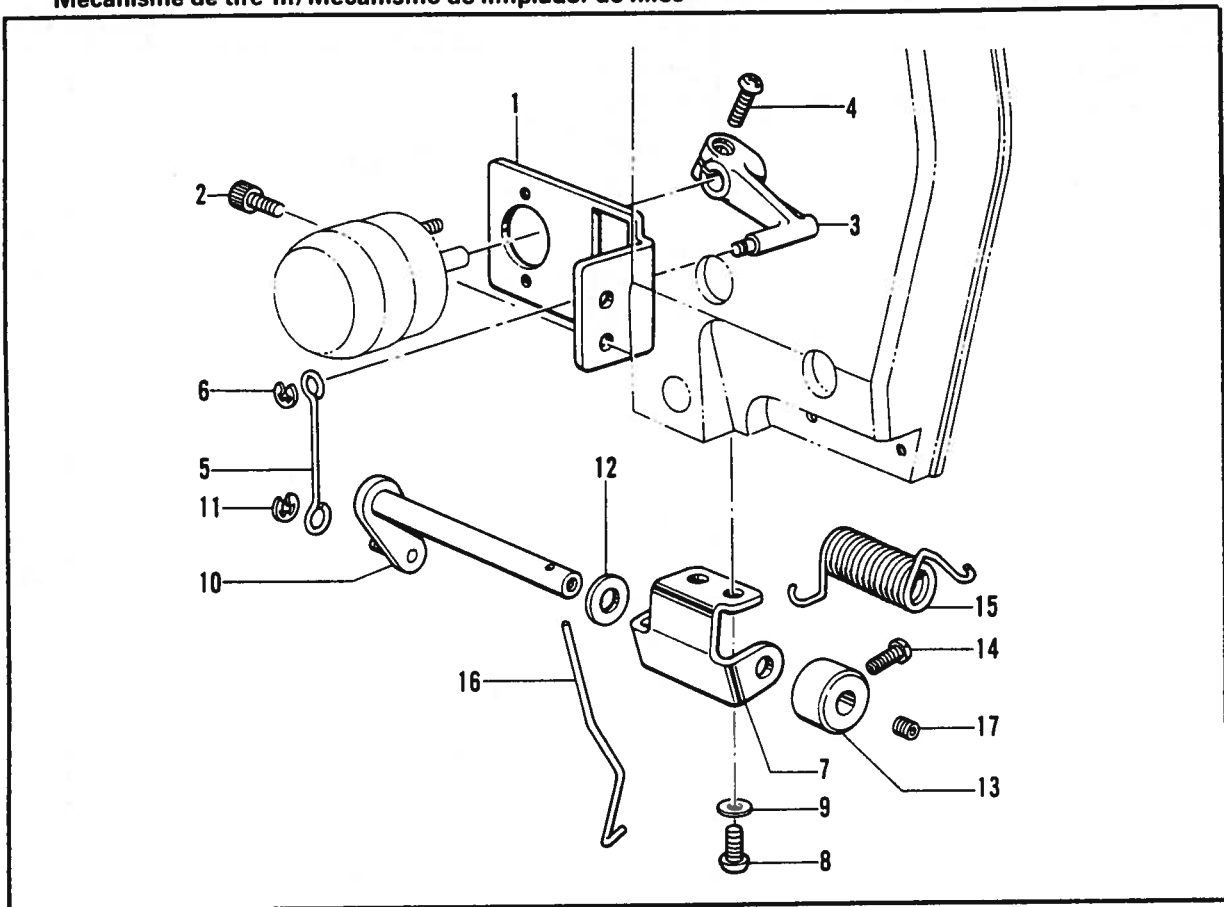

N. 針位置検出器関係/Synchronizer/Synchronisator/
 Synchronisateur/Sincronizador

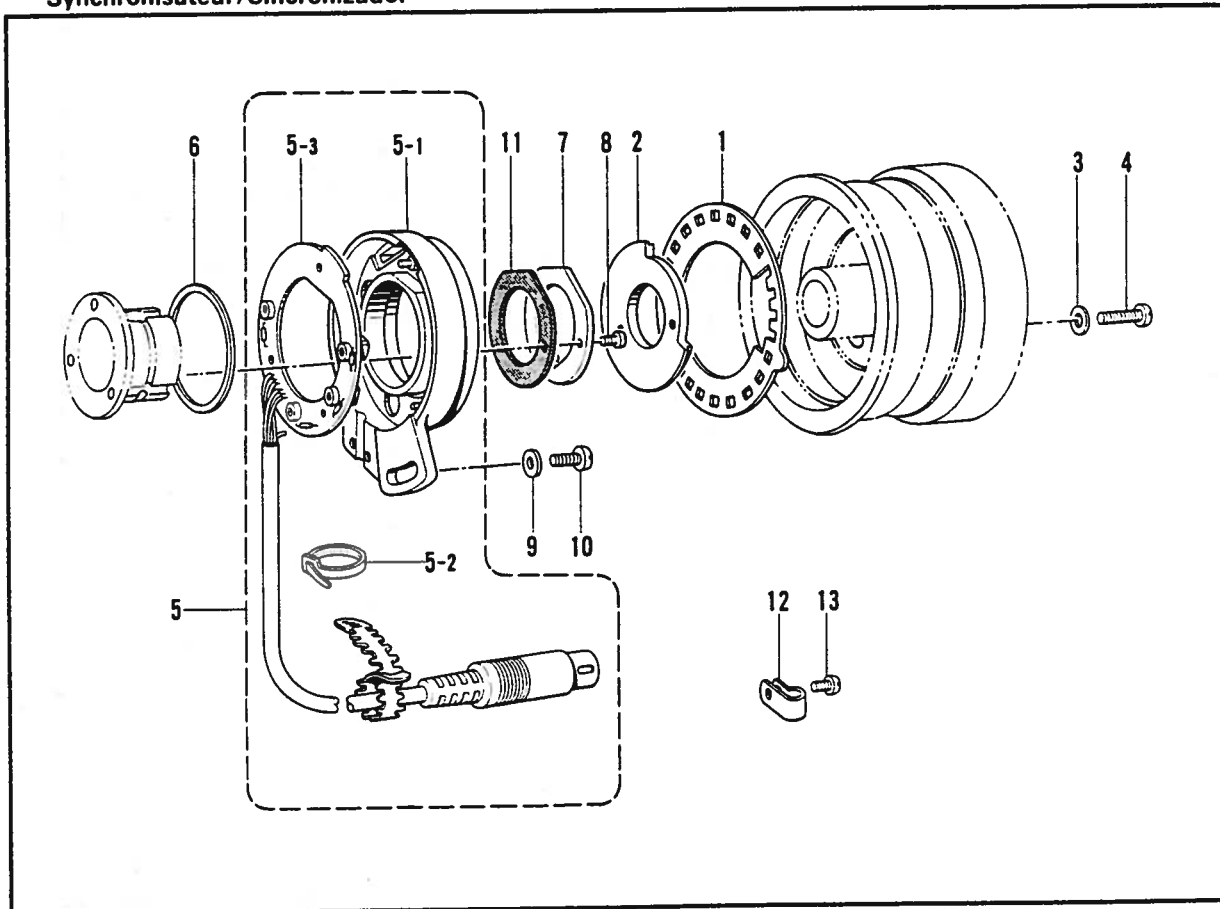

M. ワイパー関係/Thread wiper mechanism/Fadenwischvorrichtung/
Mécanisme de tire-fil/Mecanismo de limpiador de hilos

REF NO.	CODE	Q'TY	ヒンメイ	NAME OF PARTS	RMKS
1	S02440001	1	ワイパーソレノイド"タイ	WIPER SOLENOID BASE	
2	018680822	2	アナボルト4.37X8	BOLT 4.37X8	
3	146086001	1	ソレノイド"レバー	SOLENOID LEVER	
4	062671012	1	ナヘ"コ357-40X10	SCREW 3.57X10	
5	S02430001	1	ワイパーリンク	WIPER LINK	
6	048025342	1	トメワE2.5	STOP RING E2.5	
7	S02407009	1	イトハラシ"クウケイタ	WIPER SHAFT HOLDER PLATE	
8	062680512	2	ナヘ"コ437-40X5	SCREW 4.37X5	
9	025680132	2	ヒラサ"ガネシヨウ4.37	PLAIN WASHER 4.37	
10	S02456001	1	イトハライクランククミ	THREAD WIPER CRANK ASSY	
11	048030342	1	トメワE3	STOP RING E3	
12	118735001	1	サ"ガネ	WASHER	
13	147402001	1	セツカラー	SET COLLAR	
14	145992001	1	アタマツキトメネシ"4.37	SET SCREW 4.37	
15	S02870001	1	イトハライハ"ネ	SPRING	
16	S02871001	1	ワイパー	THREAD WIPER	
17	151602002	1	トメネシ"4.37	SET SCREW 4.37	

N. 針位置検出器関係/Synchronizer/Synchronisator/
Synchronisateur/Sincronizador

REF.NO.	CODE	Q'TY	ヒンメイ	NAME OF PARTS	RMKS
1	S02684001	1	ソクト"シレイタ24	SPEED COMMAND PLATE 24	
2	S02685001	1	ハリウエイタ	NEEDLE UPPER PLATE	
3	100645003	2	サ"ガネ	WASHER	
4	062681612	2	ナヘ"コ437-40X16	SCREW 4.37X16	
5	237943001	1	シンクロナイサ"クミ#13G8	SYNCHRONIZER ASSY #13G8	
5-1	S14438001	1	キハ"ンウケ#1-2	CIRCUIT BOARD BRACKET (#1-2)	
5-2	228475000	1	ケツソクハ"ント"1.9X80	TYING BAND 1.9X80	
5-3	238033001	1	SYキハ"ンクミG3	SY-CIRCUIT BOARD ASSY G3	
6	S03327000	1	シンクロナイサ"ハ"ツキン	SYNCHRONIZER PACKING	
7	S02687201	1	ケンシユツキオサエ	SYNCHRONIZER SUPPORT	
8	062630712	2	ナヘ"コ238-56X7	SCREW 238X7	
9	S10667001	1	サ"ガネ	WASHER	
10	107407003	1	シメネシ"4.37	SCREW 4.37	
11	S07885000	1	ケンシユツキオサエハ"ツキン	SYNCHRONIZER SUPPORT PACKING	
12	149547000	1	コード"オサエ	CORD HOLDER (4N)	
13	062670612	1	ナヘ"コ357-40X6	SCREW 3.57X6	

P. 電装品関係 / Power supply equipment mechanism / Stromversorgung /
 Mécanisme de l'équipement en alimentation électrique / Mecanismo del equipo de alimentación de corriente

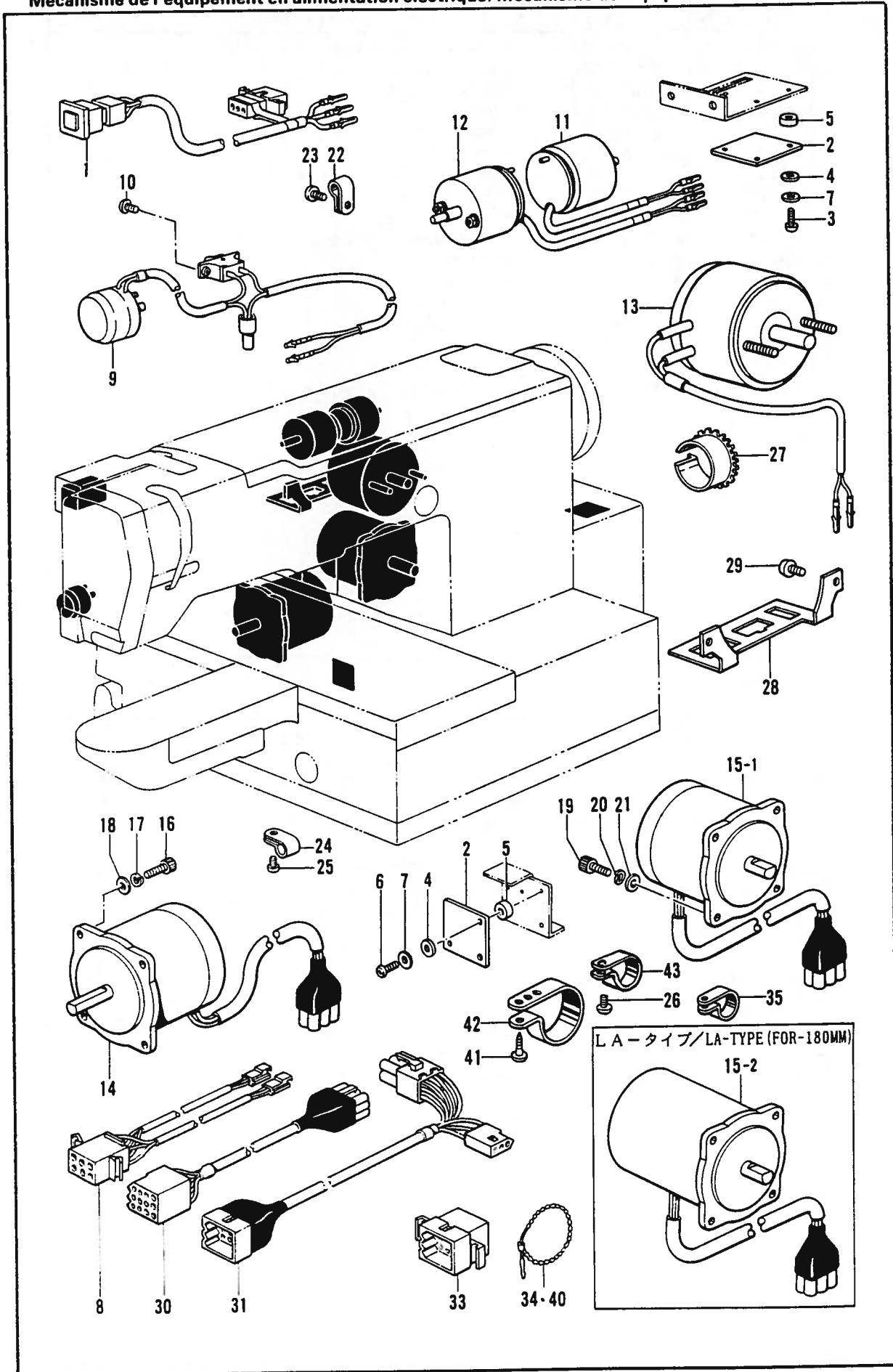

P. 電装品関係 / Power supply equipment mechanism / Stromversorgung /
 Mécanisme de l'équipement en alimentation électrique / Mecanismo del equipo de alimentación de corriente

REF. NO.	CODE	Q'TY	ヒンメイ	NAME OF PARTS	RMKS
1	S10240009	1	EMスイッチクミ	EM-SWITCH ASSEMBLY	
2	S02917001	2	ゲンテンキハツ	HOME POSITION CIRCUIT BOARD	
3	002301003	3	+ナヘ"コネシ"3X10	SCREW 3X10	
4	157704001	3	ブレーカーカラー	BREAKER COLLAR	
5	S03271001	3	Xゲンテンカラー	X-AXIS HOME POSITION COLLAR	
6	002301003	3	+ナヘ"コネシ"3X10	SCREW 3X10	
7	025030233	6	ヒラサ"カ"ネチユウ3	PLAIN WASHER 3	
8	S15142001	1	ゲンテンハーネス	HOME POSITION HARNESS	
9	S14442009	1	ワイパーソレノイド"クミ	WIPER SOLENOID ASSY	
10	062300612	2	ナヘ"コ3X6	SCREW 3X6	
11	S14439001	1	イトキリソレノイド"	THREAD TRIMMER SOLENOID	
12	S14440001	1	シユオサエソレノイド"	MAIN PRESSER SOLENOID	
13	S14441001	1	オサエアシソレノイド"	WORK CLAMP SOLENOID	
14	S17053001	1	ハ"ルスモータXクミ	PULSE MOTOR (X) ASSY	
15-1	S31604001	1	ハ"ルスモータYクミ	PULSE MOTOR (Y) ASSEMBLY	
16	018501022	4	アナホ"ルト5X10	BOLT 5X10	
17	028050242	4	ハ"ネサ"カ"ネ2-5	SPRING WASHER 2-5	
18	025050232	4	ヒラサ"カ"ネチユウ-5	PLAIN WASHER 5	
19	018501622	4	アナホ"ルト5X16	BOLT 5X16	
20	028050242	4	ハ"ネサ"カ"ネ2-5	SPRING WASHER 2-5	
21	025050232	4	ヒラサ"カ"ネチユウ-5	PLAIN WASHER 5	
22	525664000	2	コート"ホルダ"#6	CORD HOLDER (6N)	
23	060400816	2	ハ"イント"4X8	SCREW 4X8	
24	149547000	1	コート"オサエ	CORD HOLDER (4N)	
25	060400816	1	ハ"イント"4X8	SCREW 4X8	
26	062711212	1	ナヘ"コ476-32X12	SCREW 4.76X12	
27	S03283000	1	シ"サ"イフ"ツシユ	FREE BUSH	
28	S31669001	1	コネクタ"リツケイタ	CONNECTOR SET PLATE	
29	062711012	2	ナヘ"コ476-32X10	SCREW 476X10	
30	S31648001	1	ソレノイド"ハーネス326A	SOLENOID HARNESS (326A)	
31	S15156001	1	マシンヘッド"ハーネス	MACHINE HED HARNESS	
33	S10468000	1	コネクタ"1360P"ミツキ	CONNECTOR 1360P	
34	340400001	4	ユニタイ"バンド"	BEAD BAND	
35	525907000	1	コート"ホルダ"#9	CORD HOLDER (9N)	
40	340400001	4	ユニタイ"バンド"	BEAD BAND	
41	032461606	1	+マルモクネシ"4.5X16	SCREW 4.5X16	
42	158581000	1	コート"ホルダ"#24	CORD HOLDER (24N)	
43	S00470000	1	コート"ホルダ"-#16	CORD HOLDER (16N)	
<LA-タイプ (180MM)/LA-TYPE (180MM)>					
15-2	S31606001	1	ハ"ルスモータYクミ180	PULSE MOTOR (Y) ASSEMBLY (180)	

Q. 糸切れ感知関係 / Thread breakage detector mechanism / Fadenbruchfühler /
Mécanisme du détecteur de cassure du fil / Mecanismo del sensor de cortes de hilo

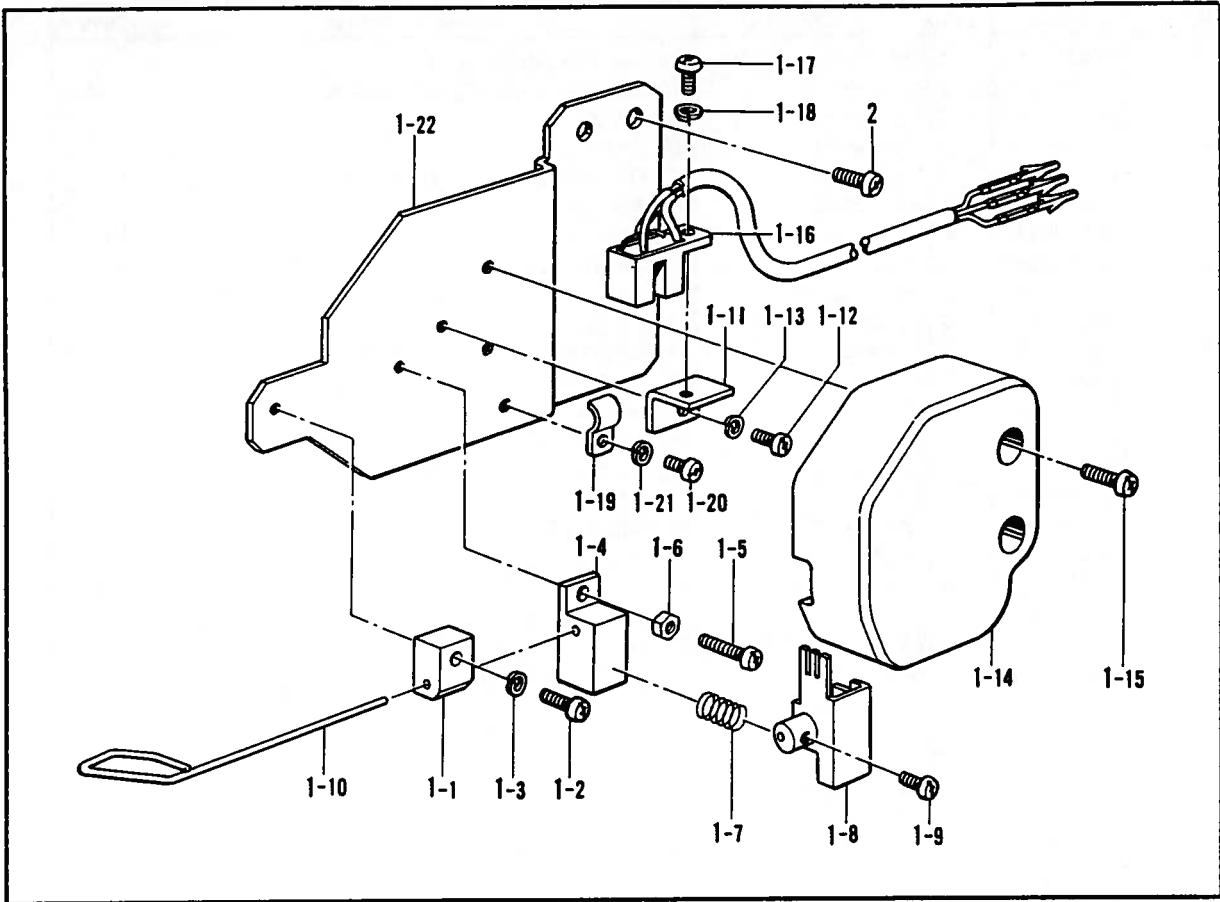

Q. 糸切れ感知関係/Thread breakage detector mechanism/Fadenbruchfühler/
 Mécanisme du détecteur de cassure du fil/Mecanismo del sensor de cortes de hilo

REF. NO.	CODE	Q'TY	品名	NAME OF PARTS	RMKS
1	S11496009	1	イトキレカンチクミ	THREAD BREAKAGE PERCEIVER ASSEMBLY	
1-1	S03861000	1	シクササEA	SHAFT SUPPORT (A)	
1-2	062301016	1	ナヘ"コM3X10	SCREW M3X10	
1-3	028030242	1	ハ"ネサ"カ"ネ2-3	SPRING WASHER 2-3	
1-4	S11687000	1	シクササEBS	SHAFT SUPPORT (BS)	
1-5	002301203	1	+ナヘ"コ3X12	SCREW 3X12	
1-6	021300103	1	ナツト1シユ3	NUT 3	
1-7	S11497001	1	センサーハ"ネ	SPRING	
1-8	S03864001	1	スリット	SLIT	
1-9	062300612	1	ナヘ"コ3X6	SCREW 3X6	
1-10	S11498000	1	カンチレハ"	PERCEIVER LEVER	
1-11	S03866001	1	トリツケイタ	SET PLATE	
1-12	062300612	1	ナヘ"コ3X6	SCREW 3X6	
1-13	028030242	1	ハ"ネサ"カ"ネ2-3	SPRING WASHER 2-3	
1-14	S03867003	1	イトキレカハ"	THREAD BREAKAGE COVER	
1-15	062401012	2	ナヘ"コM4X10	SCREW M4X10	
1-16	S17741009	1	センサーハーネスB	SENSOR HARNESS (B)	
1-17	062300612	1	ナヘ"コ3X6	SCREW 3X6	
1-18	028030242	1	ハ"ネサ"カ"ネ2-3	SPRING WASHER 2-3	
1-19	145595001	1	コード"オサイ	CORD HOLDER	
1-20	002400502	1	+ナヘ"コ4X5	SCREW 4X5	
1-21	028040242	1	ハ"ネサ"カ"ネ2-4	SPRING WASHER 2-4	
1-22	S11500001	1	センサーヘ"ース	SENSOR BASE	
2	062670812	2	ナヘ"コ3.57-40X8	SCREW 3.57X8	

R. コントロールボックス関係 / Control box mechanism / Schaltkasten /
 Mécanisme du boîtier de contrôle / Mecanismo de la caja de controles

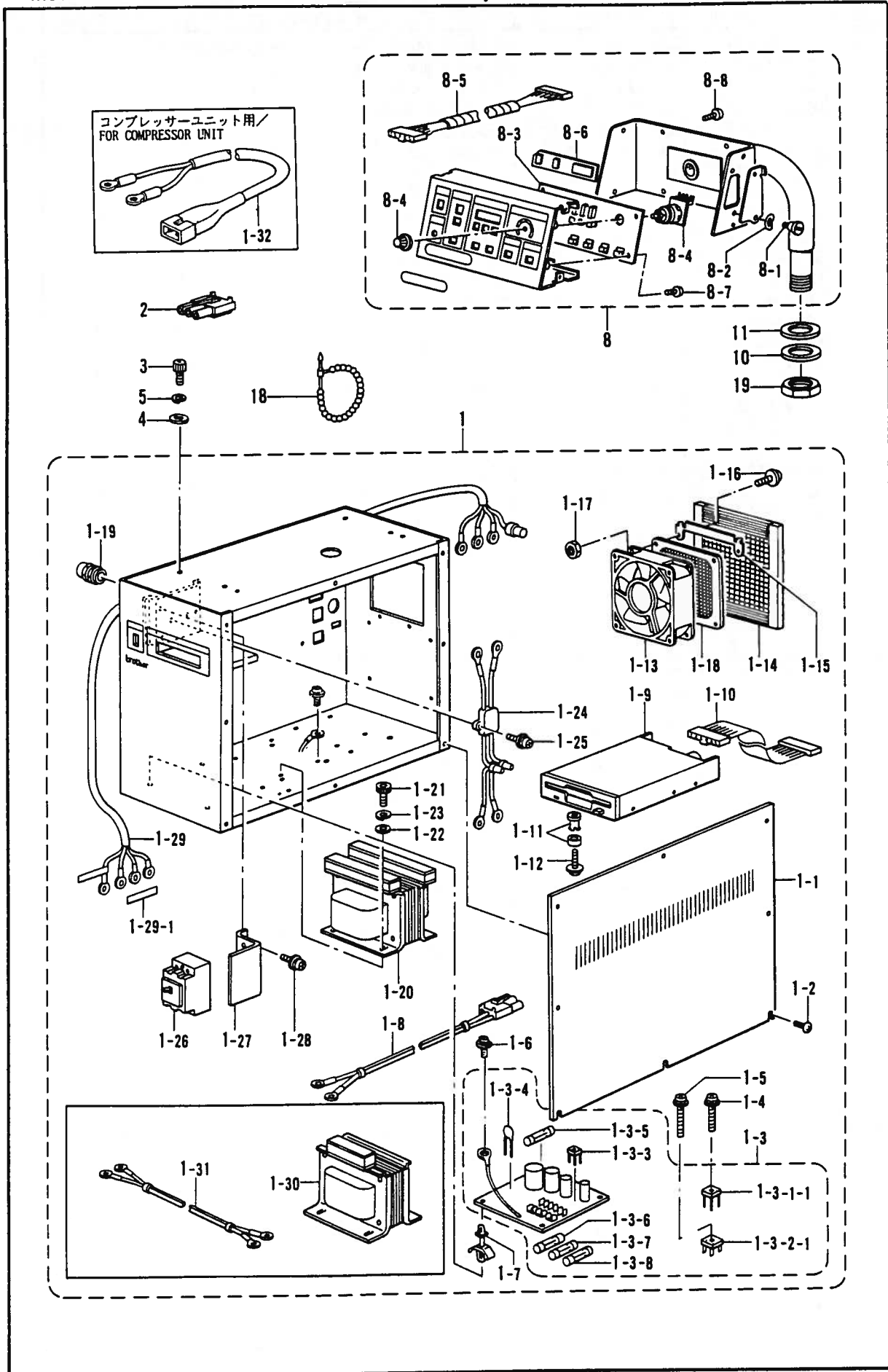

R. コントロールボックス関係/Control box mechanism/Schaltkasten/
Mécanisme du boîtier de contrôle/Mecanismo de la caja de controles

REF.NO.	CODE	Q'TY	ヒンメイ	NAME OF PARTS	RMKS
< 3ソウ 200V, 220V/THREE-PHASE 200V, 220V >					
1	S30175109	1	デ"ンゲ"ンホ"ツクスミA	POWER SUPPLY BOX ASSY (A)	
1-8	S30249001	1	フィルタINコート"クミ	FILTER IN CORD ASSY	
1-20	S30232000	1	トランス300A	TRANSFORMER 300A	
1-24	S30250001	1	ノイズ"フィルタ-3A	NOISE FILTER (3A)	
1-26	S21181000	1	ブ"レーカーF5A	BREAKER (F5A)	
1-29	S30238001	1	デ"ンゲ"ンコート"	POWER SUPPLY CORD	
1-29-1	S31650000	1	セツメイシール	DIAGRAM SEAL	
< タンソウ 100V, 110V/SINGLE-PHASE 100V, 110V >					
1	S30265109	1	デ"ンゲ"ンホ"ツクスミB	POWER SUPPLY BOX ASSY (B)	
1-8	S30282001	1	フィルタINコート"クミBC	FILTER IN CORD ASSY	
1-20	S30233000	1	トランス300B	TRANSFORMER 300B	
1-24	S30264001	1	ノイズ"フィルタ-5A	NOISE FILTER (5A)	
1-26	S21504000	1	ブ"レーカーF10A	BREAKER (F10A)	
1-29	S31585001	1	デ"ンゲ"ンコート"コクナイ	POWER SUPPLY CORD FOR DOMESTIC	
1-30	S30285000	1	ヘンカントランスB	CONVERSION TRANSFORMER (B)	
1-31	S30281001	1	トランスコート"	TRANSCORD	
< 3ソウ 240V, 380V, 415V/THREE-PHASE 200V, 220V, 415V >					
1	S30266109	1	デ"ンゲ"ンホ"ツクスミC	POWER SUPPLY BOX ASSY (C)	
1-8	S30282001	1	フィルタINコート"クミBC	FILTER IN CORD ASSY	
1-20	S30234000	1	トランス300C	TRANSFORMER 300C	
1-24	S30250001	1	ノイズ"フィルタ-3A	NOISE FILTER (3A)	
1-26	S21181000	1	ブ"レーカーF5A	BREAKER (F5A)	
1-29	S30238001	1	デ"ンゲ"ンコート"	POWER SUPPLY CORD	
1-29-1	S31650000	1	セツメイシール	DIAGRAM SEAL	
1-30	S30286000	1	ヘンカントランスC	CONVERSION TRANSFORMER (C)	
1-31	S30281001	1	トランスコート"	TRANSCORD	
< タンソウ 220V, 240V/SINGLE-PHASE 220V, 240V >					
1	S30269109	1	デ"ンゲ"ンホ"ツクスミF	POWER SUPPLY BOX ASSY (F)	
< コンプレッサーヨウ >					
< 100V >					
1	S30268109	1	デ"ンゲ"ンホ"ツクスミE	-----	
1-32	S10465001	1	コンプレッサーハーネス	-----	
< 200V >					
1	S30267109	1	デ"ンゲ"ンホ"ツクスミD	-----	
1-32	S10465001	1	コンプレッサーハーネス	-----	
1-1	S18507101	1	ホ"ツクスフタ	BOX COVER	
1-2	008400604	6	+トラスコ4X6	SCREW 4X6	
1-3	S29009001	1	デ"ンゲ"ンキハ"ンクミ	POWER SUPPLY CIRCUIT BOARD ASSY	
1-3-1-1	S08032000	1	SIBRS10VB60	SIBRS10VB60	
1-3-1-2	S10315000	2	SIBRS15VB10	SIBRS15VB10	
1-3-3	S30224000	1	SIDS3WB10	SIDS3W10	
1-3-4	S30227000	1	ZNRC20DK391	ZNRC20DK391	
1-3-5	S08030000	1	Gヒューズ"5AFB	G FUSE (5AFB)	
1-3-6	S02887000	1	ヒューズ"15A	FUSE (15A)	
1-3-7	152565000	1	ヒューズ"B	FUSE (B)	
1-3-8	152566000	1	ヒューズ"C	FUSE (C)	
1-4	0A4301605	1	+ナヘ"サ"クミ3X16DA	SCREW SET 3X16DA	
1-5	0A5402005	2	+ナヘ"サ"クミ4X20DB	SCREW SET 4X20DB	
1-6	0A5401005	1	+ナヘ"サ"クミ4X10DB	SCREW SET 4X10DB	
1-7	S00554000	17	サポ"ート6NS	SUPPORT 6NS	
1-9	S16661001	1	3.5フロッピー"ート"ライブ"	3.5 INCH FLOPPY DRIVE	
1-10	S10283001	1	フロッピー"ーハーネス	FLOPPY HARNESS	
1-11	S18573000	4	ワンタッチカラー"ブ"ツシユ	ONE-TOUCH COLLAR BUSH	
1-12	0A5301405	4	+ナヘ"サ"クミ3X14DB	SCREW SET 3X14DB	
1-13	S16566000	1	クー"リング"ファン	COOLING FAN	
1-14	S10336000	1	ファン"ガード"	FAN GUARD	
1-15	S10289000	2	ファン"リツク"カナク"	FAN SET PLATE	
1-16	0A5301205	8	+ナヘ"サ"クミ3X12DB	SCREW SET 3X12DB	
1-17	021300206	4	2シユナツト3	NUT 3	
1-18	S16567000	1	ファン"フィルタ"ー	FAN FILTER	

R. コントロールボックス関係 / Control box mechanism / Schaltkasten /
 Mécanisme du boîtier de contrôle / Mecanismo de la caja de controles

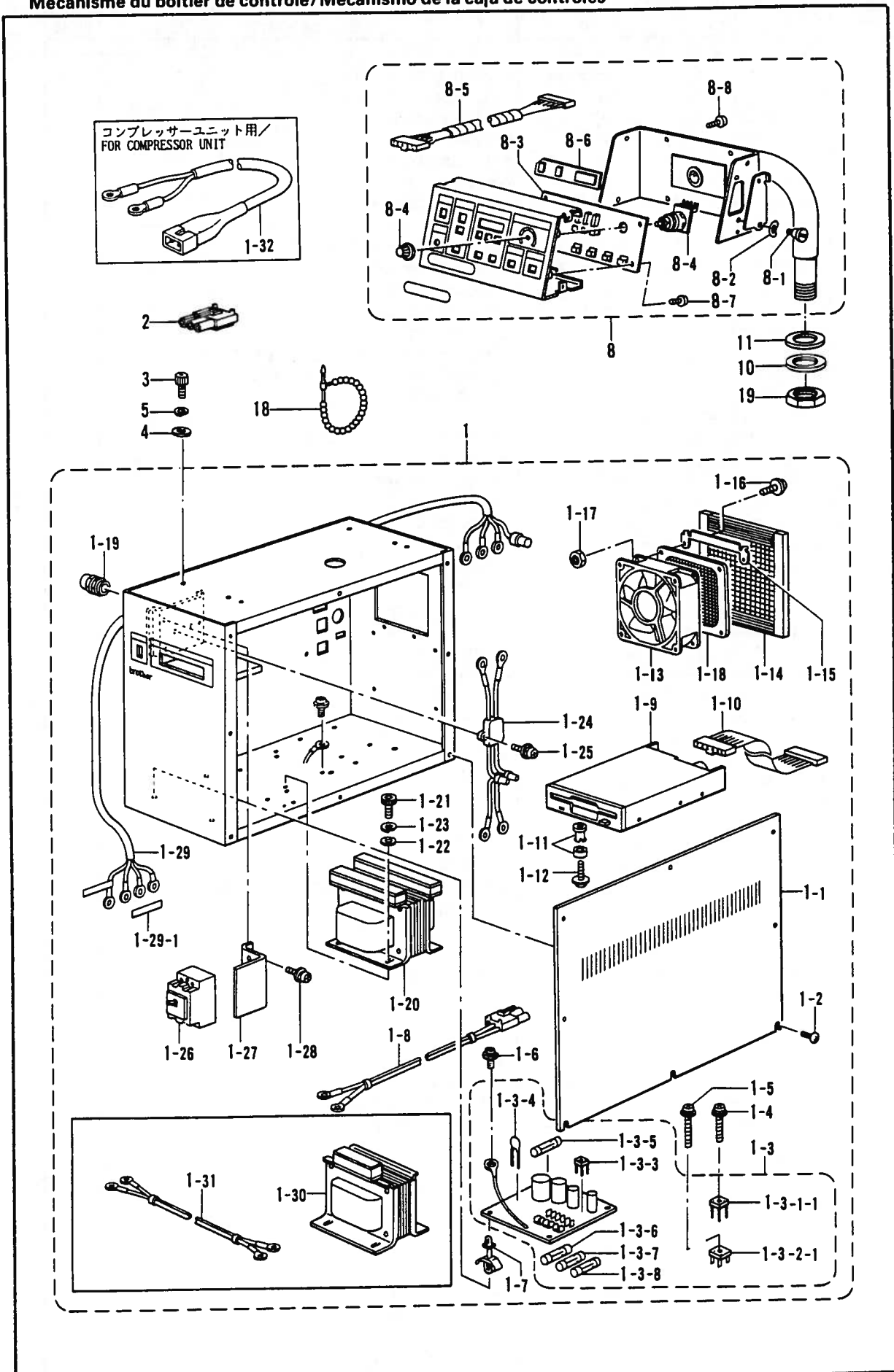

R. コントロールボックス関係 / Control box mechanism / Schaltkasten /
 Mécanisme du boîtier de contrôle / Mecanismo de la caja de controles

REF NO	CODE	Q'TY	ヒンメイ	NAME OF PARTS	RMKS
1-19	152510000	2	コードフツシユ	CORD BUSH	
1-21	018061036	4	アナボルト6X10	BOLT 6X10	
1-22	025060236	4	ヒラサ"カ"ネチユ6	PLAIN WASHER 6	
1-23	028060246	4	ハ"ネサ"カ"ネ2-6	SPRING WASHER 2-6	
1-25	0A5301005	2	+ナヘ"サ"クミ3X10DB	SCREW SET 3X10DB	
1-27	S30251001	1	フ"レー"カト"リツケイタ	BREAKER SET PLATE	
1-28	0A5400805	2	+ナヘ"サ"クミ4X8DB	SCREW SET 4X8DB	
2	S16568000	1	コネクタ3191-03R1	CONNECTOR (3191-03R1)	
3	018083022	4	アナボルト8X30	BOLT 8X30	
4	025080232	4	ヒラサ"カ"ネチユ8	PLAIN WASHER 8	
5	028080242	4	ハ"ネサ"カ"ネ2-8	SPRING WASHER 2-8	
8	S16575109	1	ソウサハコクミ	OPERATION BOX ASSY	
8-1	107321003	1	タ"ンネシ"4.76	STUD SCREW 4.76	
8-2	107017002	1	ナミハ"ネサ"カ"ネ	WAVE SPRING WASHER	
8-3	S16578101	1	キハ"ンB439054クミ	CIRCUIT BOARD (B439054) ASSY	
8-4	S10401001	1	スピ"ート"ホ"リウムクミ	SPEED VOLUME ASSY	
8-5	S18101001	1	ハ"ネル"ハーネス	PANEL HARNESS	
8-6	S16580000	1	LEDカハ"ー	LED COVER	
8-7	0A5400805	4	+ナヘ"サ"クミ4X8DB	SCREW SET 4X8DB	
8-8	008400604	8	+トラスコ4X6	SCREW 4X6	
10	S10408000	1	ゴ"ムシート	RUBBER SHEET	
11	S18271009	1	サ"カ"ネ	WASHER	
18	340400001	5	ユニタイ"バンド"	BEAD BAND	
19	S17986001	1	ナツト30	NUT 30	

S. 空圧関係 / Air pressure mechanism / Luftdruck /
 Mécanisme de la pression d'air / Mecanismo de la presión de aire

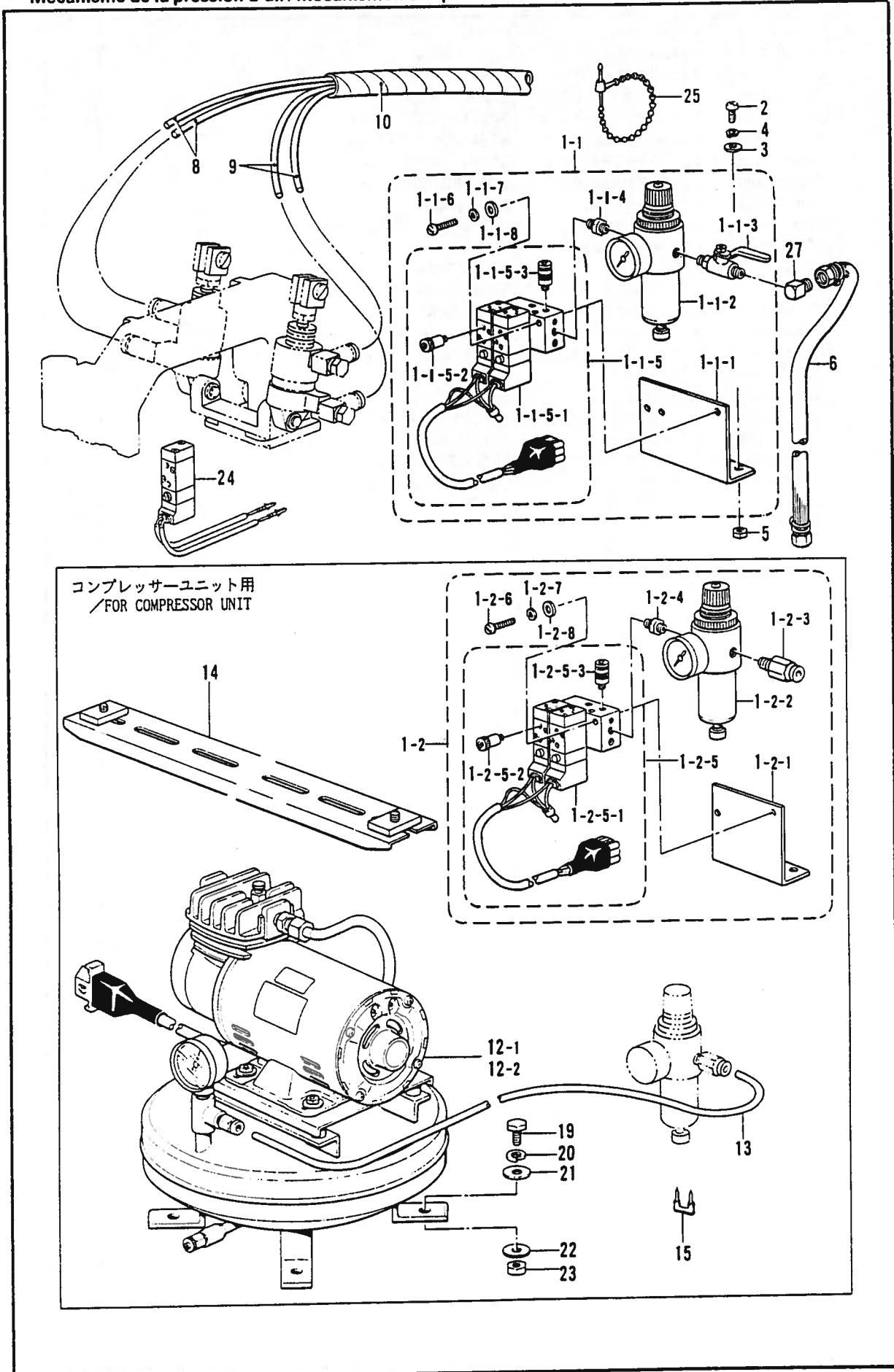

S. 空圧関係/Air pressure mechanism/Luftdruck/
Mécanisme de la pression d'air/Mecanismo de la presión de aire

REF.NO.	CODE	Q'TY	ヒンメイ	NAME OF PARTS	RMKS
1-1	S30616009	1	テ"ンシ"ハ"ルフ"2Aクミ	AIR VALVE (2A) ASSY	
1-1-1	S31551009	1	ハ"ルフ"トリツケイタ2-3	VALVE SET PLATE 2-3	
1-1-2	S09318101	1	インテク"レータ	INTEGRATER	
1-1-3	S09231000	1	ホ"ールハ"ルフ"1/4	BALL VALVE 1/4	
1-1-4	S09228000	1	イクイニツプル	NIPPLE	
1-1-5	S30617001	1	テ"ンシ"ハ"ルフ"2クミ	AIR VALVE (2) ASSY	
1-1-5-1	S03789001	1	エアマニホルト"クミ	AIR MANIFOLD ASSY	
1-1-5-2	S03792001	4	ハイキシホ"リヘ"ン	EXHAUST THROTTLE VALVE	
1-1-5-3	S18415001	4	ハーフユニオンQ4M5	HALF UNION	
1-1-6	062302506	2	ナヘ"コ3X25	SCREW 3X25	
1-1-7	028030242	2	ハ"ネサ"カ"ネ2-3	SPRING WASHER 2-3	
1-1-8	025030232	2	ヒラサ"カ"ネチユウ3	PLAIN WASHER 3	
2	062501202	2	ナヘ"コM5X12	SCREW M5X12	
3	025050232	2	ヒラサ"カ"ネチユウ5	PLAIN WASHER 5	
4	028050242	2	ハ"ネサ"カ"ネ2-5	SPRING WASHER 2-5	
5	021500103	2	ナツト1シユ5	NUT 5	
6	149796001	1	ゴムホースカナク"ツキ	AIR TUBE WITH CONNECTOR	
8	S10386100	2	ナイロンチューブ"R	NYLON TUBE (R)	
9	S10387100	2	ナイロンチューブ"L	NYLON TUBE (L)	
10	S15078000	2	スパイラルチューブ"	SPIRAL TUBE	
25	340400001	1	ユニタイハ"ント"	BEAD BAND	
27	S32334000	1	PTチーズ"1/4	PT CHEESE 1/4	
<コンプレッサー"ヨウ">					
1-2	S30618009	1	テ"ンシ"ハ"ルフ"2Bクミ	-----	
1-2-1	S31551009	1	ハ"ルフ"トリツケイタ2-3	-----	
1-2-2	S09318101	1	インテク"レータ	-----	
1-2-3	S29710000	1	コネクタ"6-1/4	-----	
1-2-4	S09228000	1	イクイニツプル	-----	
1-2-5	S30617001	1	テ"ンシ"ハ"ルフ"2クミ	-----	
1-2-5-1	S03789001	1	エアマニホルト"クミ	-----	
1-2-5-2	S03792001	4	ハイキシホ"リヘ"ン	-----	
1-2-5-3	S18415001	4	ハーフユニオンQ4M5	-----	
1-2-6	062302506	2	ナヘ"コ3X25	-----	
1-2-7	028030242	2	ハ"ネサ"カ"ネ2-3	-----	
1-2-8	025030232	2	ヒラサ"カ"ネチユウ3	-----	
13	S32129000	1	ナイロンチューブ"	-----	
14	S10463102	1	フミイタササエタ"イ	-----	
15	200190001	3	ステップル	-----	
19	017082203	4	ホルト8X22	-----	
20	028080242	4	ハ"ネサ"カ"ネ2-8	-----	
21	025080232	4	ヒラサ"カ"ネチユウ8	-----	
22	025080336	4	ヒラサ"カ"ネタ"イ8	-----	
23	021080106	4	ナツト1シユ8	-----	
<100V">					
12-1	S05670002	1	コンプレッサーユニット	-----	
<200V">					
12-2	S09393002	1	コンプレッサーユニット	-----	
<ホキユウヨウ /FOR SUPPLY">					
24	S30609001	1	テ"ンシ"ハ"ルフ"1クミ	AIR VALVE (1) ASSY	

T. プリント基板関係 / Printed circuit board mechanism / Leiterplatten /
Circuits imprimés / Tableros de circuitos impresos

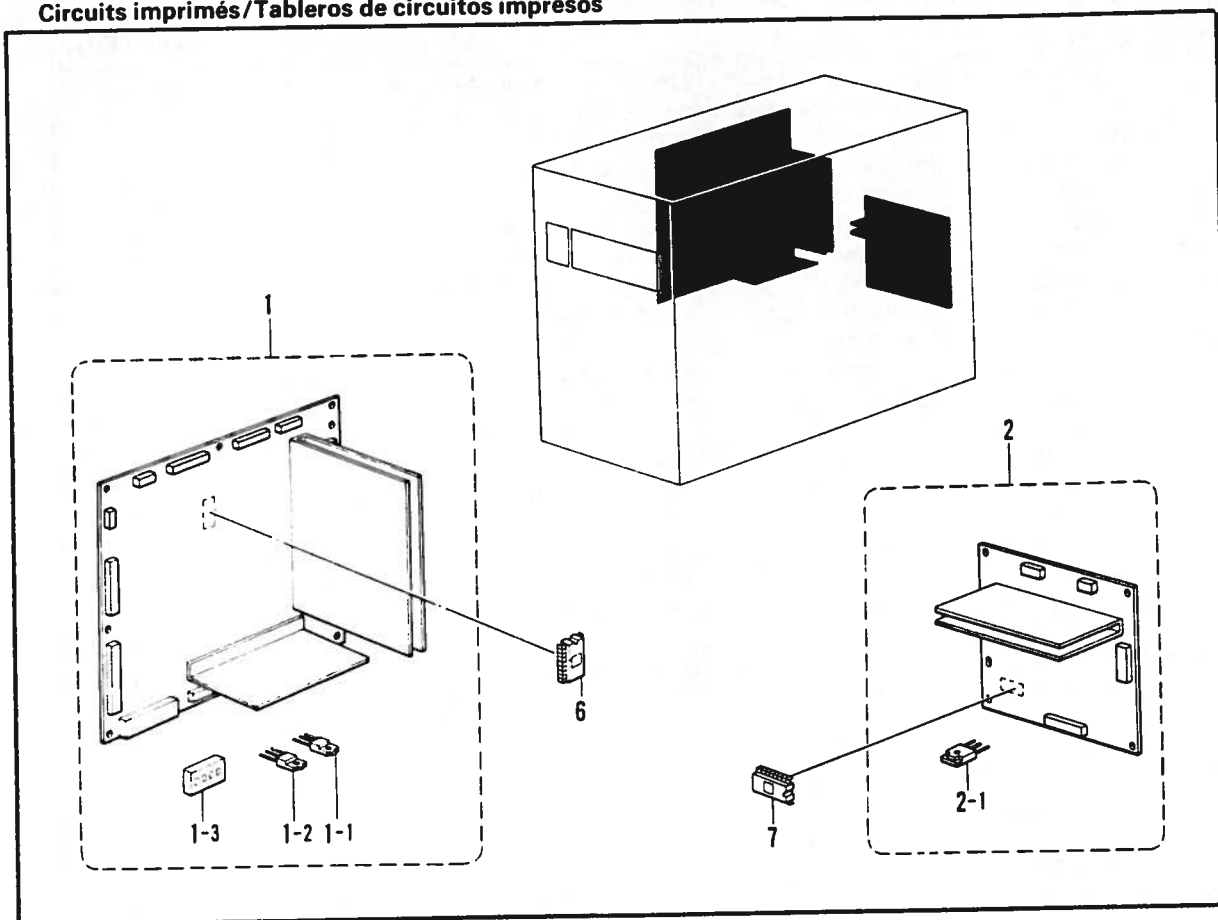

U. 踏板関係 / Foot switch pedal mechanism / Fußbetätigung /
Mécánisme de la pédale / Mecanismo del pedal

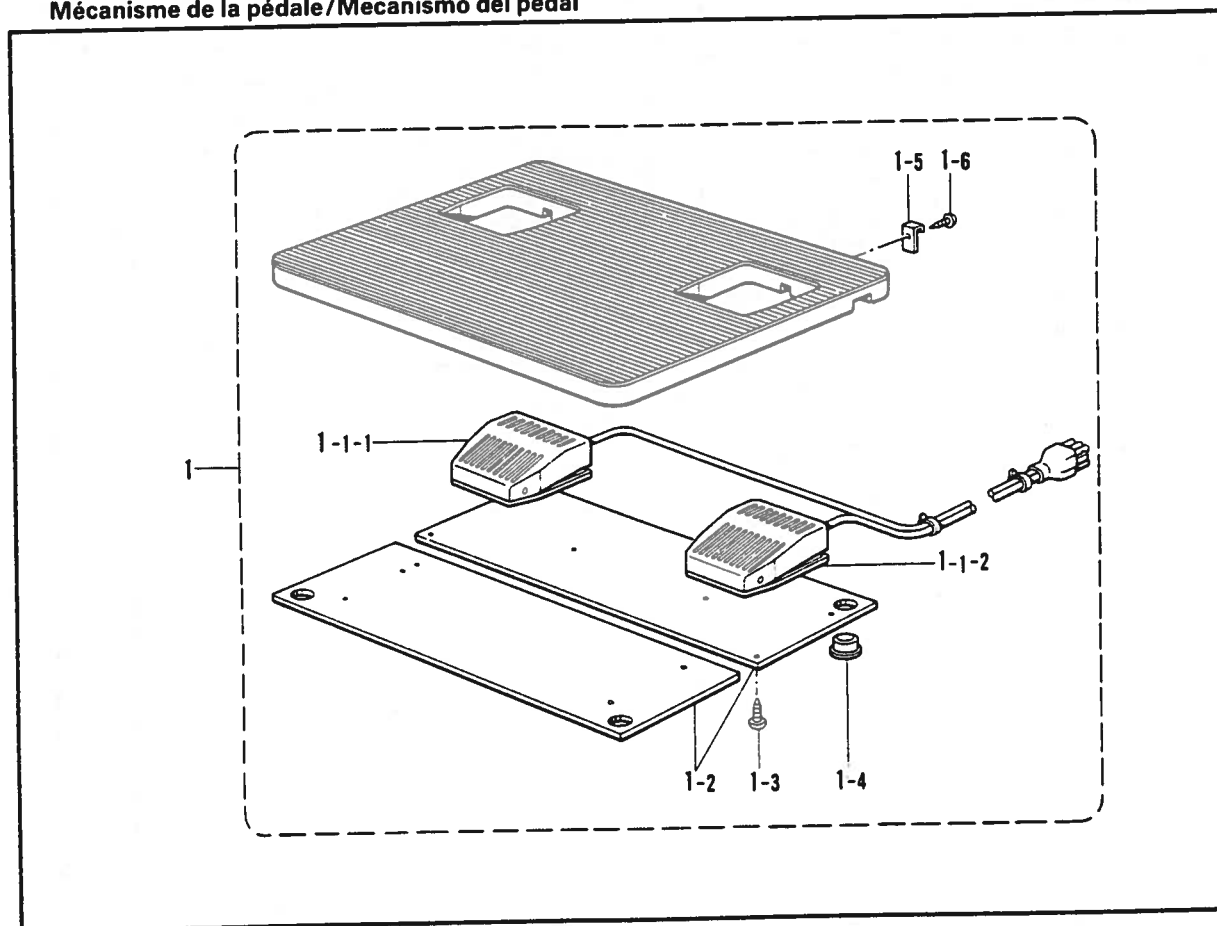

T. プリント基板関係/Printed circuit board mechanism/Leiterplatten/
Circuits imprimés/Tableros de circuitos impresos

REF.NO.	CODE	Q'TY	ヒンメイ	NAME OF PARTS	RMKS
1	S29007001	1	メインキハ"ンクミ	MAIN CIRCUIT BOARD ASSY	
1-1	U31357000	8	SITR2SB951A	SILICON TRANSISTOR 2SB951A	
1-2	U31359000	12	SITR2SD1277B	SILICON TRANSISTOR 2SD1277B	
1-3	T22706000	1	DIPSW KSD04	DIPSW KSD04	
2	S29008001	1	モータキハ"ンクミ	MOTOR CIRCUIT BOARD ASSY	
2-1	S30206000	6	MOSFET2SK1936	MOSFET2SK1936	
6	S30253001	1	PROMセイキ"ヨクミ	PROM CONTROL ASSY	
7	S30254001	1	PROMモータクミ	PROM MOTOR ASSY	

U. 踏板関係/Foot switch pedal mechanism/Fußbetätigung/
Mécanisme de la pédale/Mecanismo del pedal

REF.NO.	CODE	Q'TY	ヒンメイ	NAME OF PARTS	RMKS
1	S32342009	1	フットスイッチイタスクミ	FOOT SWITCH PLATE (S) ASSY	
1-1	S32343001	1	フットスイッチ2タ"ンクミ	FOOT SWITCH 2-STAGE ASSY	
1-1-1	S32344001	1	2タ"ンスイッチクミ	2-STAGE SWITCH ASSY	
1-1-2	S32345001	1	1タ"ンスイッチ	1-STAGE SWITCH	
1-2	S02977101	2	スイッチウケ	SWITCH SUPPORT PLATE	
1-3	034311302	10	+サラモクネシ"3.1X13	SCREW 3.1X13	
1-4	159150009	4	カマシ"クメクラセン	OIL CAP	
1-5	S01825001	2	フミイタカケ	TREADLE HOOK	
1-6	031312006	2	マルモクネシ"3.1X20	SCREW 3.1X20	

V. 動力台関係 / Power table / Motorgestell /
 Mécanisme du plateau de la machine / Mecanismo de la mesa de la máquina

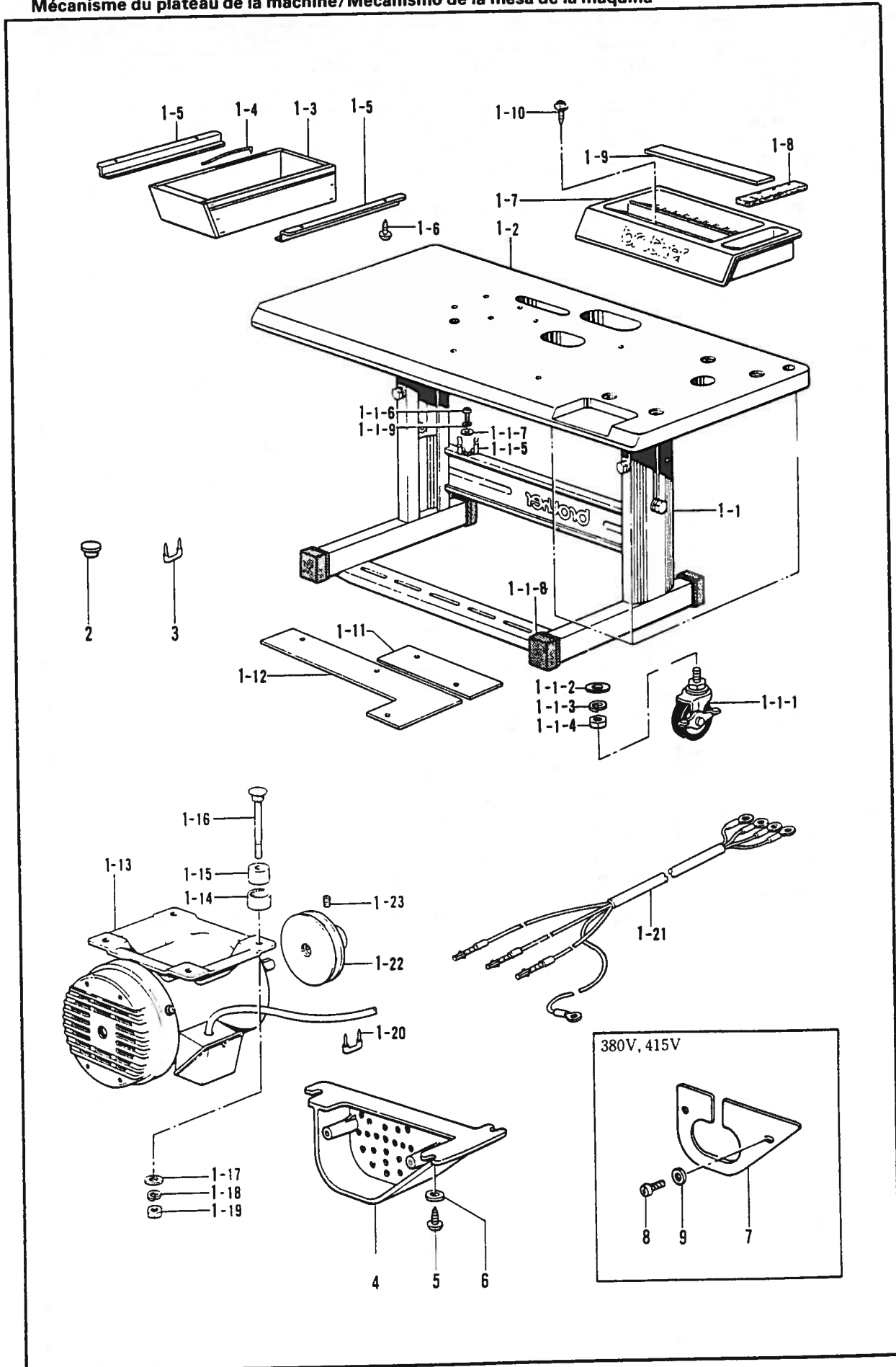

V. 動力台関係/Power table/Motorgestell/
Mécanisme du plateau de la machine/Mecanismo de la mesa de la máquina

REF NO.	CODE	QTY	ヒンメイ	NAME OF PARTS	RMKS
1	S31645009	1	テーブルキヤクミ	TABLE STAND ASSY	
1-1	S10355109	1	タチスフリケンヨウキヤクミ	COMPATIBLE STAND ASSY	
1-1-1	S05223001	4	キヤスター	CASTER	
1-1-2	026120236	4	ヒラサ"カ"ネミカ"キ12	PLAIN WASHER 12	
1-1-3	028120246	4	ハ"ネサ"カ"ネ2-12	SPRING WASHER 2-12	
1-1-4	021120304	4	ナツト3シユ12	NUT 12	
1-1-5	133172003	1	アフ"ラサシタ"イ	OIL BRACKET	
1-1-6	037521016	1	+ナヘ"タツヒ"ン 2シユ5	SCREW 5	
1-1-7	025050236	1	ヒラサ"カ"ネチユウ-5	PLAIN WASHER 5	
1-1-8	S10661009	4	ソトアシフタゴム	RUBBER	
1-1-9	028050246	1	ハ"ネサ"カ"ネ2-5	SPRING WASHER 2-5	
1-2	S31646009	1	テーブル	TABLE	
1-3	119702004	1	ヨコヒキタ"シ	SIDE DRAWER	
1-4	101073001	1	ヒキタ"シコテイハ"ネ	SPRING	
1-5	101121003	2	ヨコヒキタ"シササエ	SIDE DRAWER SUPPORT	
1-6	032361306	4	+マルモクネシ"3.5X13	SCREW 3.5X13	
1-7	S15158009	1	コモノケース	ACCESSORY CASE	
1-8	S02740000	1	フェルト	FELT	
1-9	S02739000	1	ゴムシ"シヤクテープ"	RUBBER MAGNET TAPE	
1-10	S10476001	2	ハ"ンワツシヤタツヒ"ンネシ"	SCREW	
1-11	S14508000	1	アースイタA	EARTH PLATE (A)	
1-12	S14509000	1	アースイタB	EARTH PLATE (B)	
1-13	S10405000	1	ゼ"ンヘイ3ソウモータ	TOTALLY ENCLOSED MOTOR 3-PHASE	
1-14	146256001	4	クツシヨンカナク"	CUSHION COLLAR	
1-15	146255000	4	クツシヨン	CUSHION	
1-16	133740006	4	カクネホ"ルト6X70	BOLT 6X70	
1-17	025060336	4	ヒラサ"カ"ネタ"イ6	PLAIN WASHER 6	
1-18	028060246	4	ハ"ネサ"カ"ネ2-6	SPRING WASHER 2-6	
1-19	021060106	4	ナツト1シユ6	NUT 6	
1-20	200190001	3	ステツアル	STAPLE	
1-21	S17998001	1	モータハーネス	MOTOR HARNESS	
1-22	S10264101	1	モータプーリ	MOTOR PULLEY	
1-23	014760622	1	アナトメネシ"5.95	SET SCREW 5.95	
2	159150009	4	カマシ"クメクラセン	OIL CAP	
3	200190001	2	ステツアル	STAPLE	
4	S18633109	1	モーターカハ"	MOTOR COVER	
5	032422003	3	+マルモクネシ"4.1X20	SCREW 4.1X20	
6	116662003	3	サ"カ"ネ	WASHER	
<380V, 415V>					
7	S20137001	1	モーターウシロカハ"	MOTOR BACK COVER	
8	138444001	2	ナヘ"Bタイト4X14	SCREW	
9	025040232	2	ヒラサ"カ"ネチユウ4	PLAIN WASHER 4	

W. 付属装置関係 / Programmer device / Programmvorrichtung /
 Dispositif du programmeur / Programadora

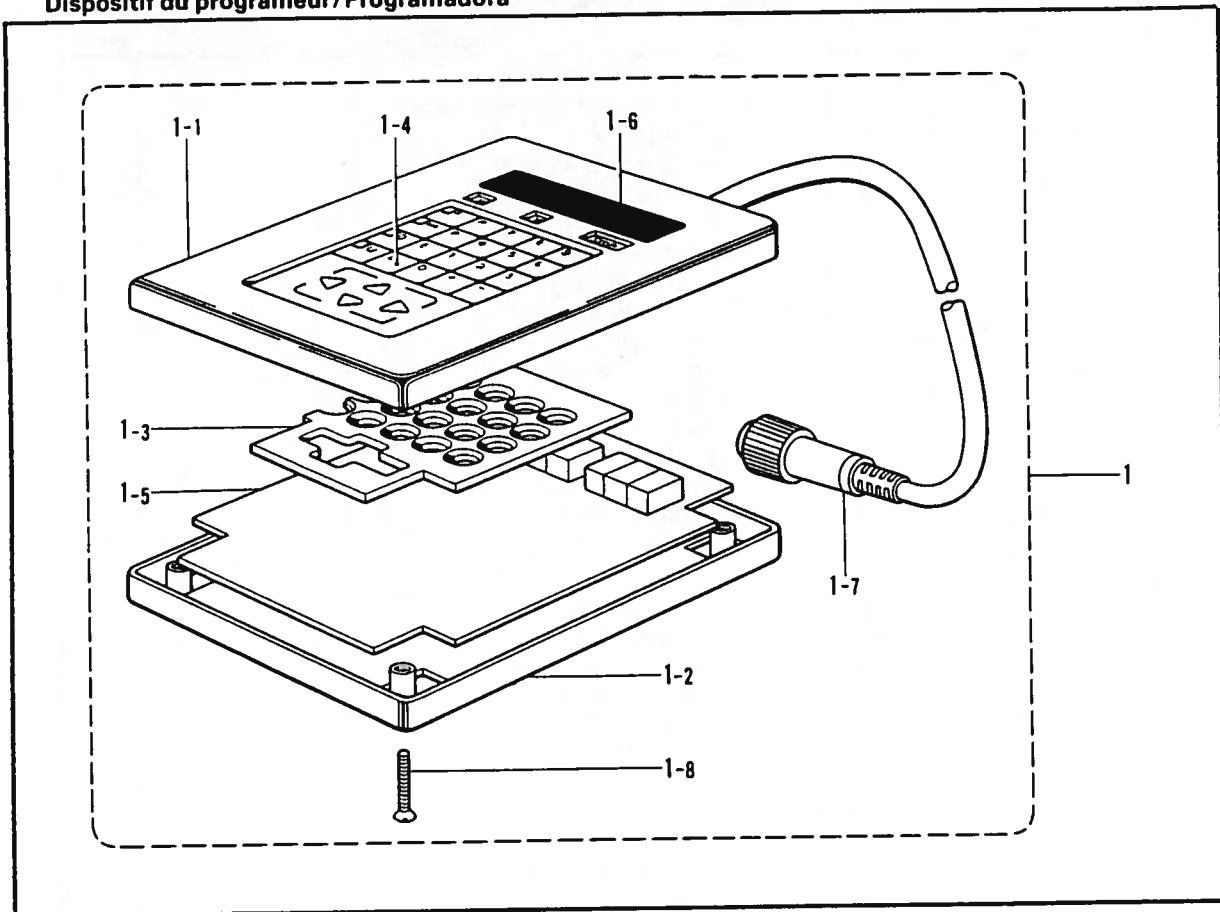

X1. 付属装置セット / Attachment set / Anbausatz /
 Jeu d'accessoires / Juego de fijación

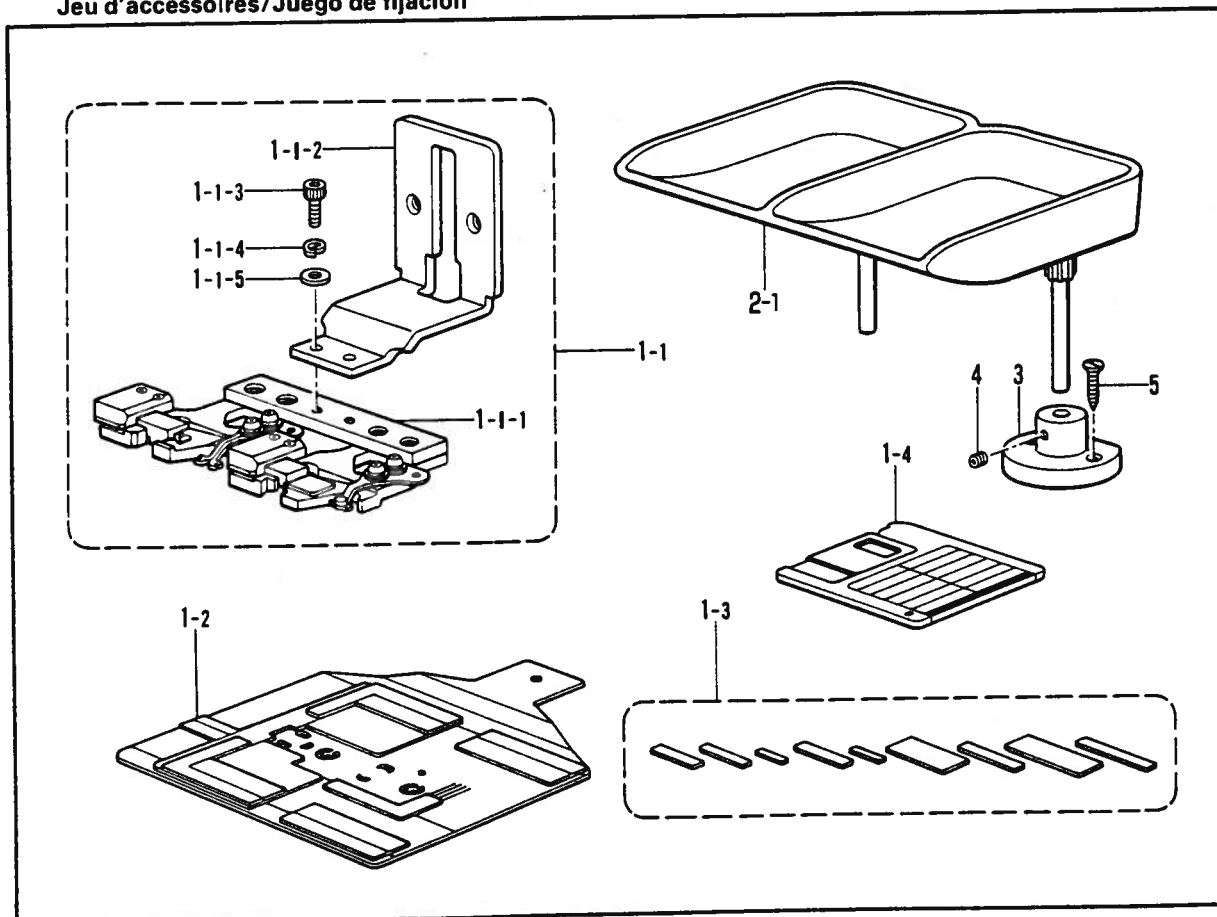

W. 付属装置関係 / Programmer device / Programmvorrichtung /
Dispositif du programmeur / Programadora

REF. NO.	CODE	Q'TY	ヒンメイ	NAME OF PARTS	RMKS
1	S02939009	1	プログラママークミ	PROGRAMMER ASSY	
1-1	S02940001	1	プログラマハコウエ	PROGRAMMER COVER (U)	
1-2	S02941001	1	プログラマハコシタ	PROGRAMMER COVER (D)	
1-3	S02942001	1	スペーサー	SPACER	
1-4	S02943009	1	キーボードシート	KEY BOARD SHEET	
1-5	S02947001	1	プログラマキハシBクミ	PROGRAMMER CIRCUIT BOARD ASSY (B)	
1-6	S02949001	1	スクリーンパネル	SCREEN PANEL	
1-7	S02950001	1	プログラマハーネスA	PROGRAMMER HARNESS (A)	
1-8	061302506	4	サラゴ3X25	SCREW 3X25	

X1. 付属装置セット / Attachment set / Anbausatz /
Jeu d'accessoires / Juego de fijación

REF.NO.	CODE	Q'TY	ヒンメイ	NAME OF PARTS	RMKS
1	S09645001	1	326-S.Hソウチソウクミ	SNAP AND HOOK DEVICE UNIT	
1-1	S21119001	1	オサIS.Hソウクミ326	PRESSER FOOT (S.H) ASSY 326	
1-1-1	S13818001	1	オサIS.Hクミ	PRESSER FOOT (S.H) ASSY	
1-1-2	S21116001	1	オサエアシS.H326	PRESSER FOOT (S.H) 326	
1-1-3	018401022	2	アナボルト4X10	BOLT 4X10	
1-1-4	028040232	2	ハネサカネ2-4	SPRING WASHER 2-4	
1-1-5	025040232	2	ヒラサカネチュウ4	PLAIN WASHER 4	
1-2	S09647001	1	オクリイタS.Hクミ	FEED PLATE (S.H) ASSY	
1-3	S13807000	1	ゲージS.Hクミ	GAUGE (S.H) ASSY	
1-4	S21518001	1	3.5メデ"イアS.H-1	3.5 MEDIA S.H-1	
2	S18641009	1	ボタンサラフクロイリ	BUTTON TRAY BAG	
2-1	S18642009	1	ボタンサラ	BUTTON TRAY	
3	153843009	1	ボタンサラアシホルダ	BUTTON HOLDER	
4	014760622	1	アタメネシ"5.95	SET SCREW 5.95	
5	101795001	2	サラモクネシ"3.5X16	SCREW 3.5X16	

X2. ネーム付反転装置 エアー仕様 / Reversing device for label sewing, pneumatic drive (option) /
 Umkehrvorrichtung zum Etikettannähen, pneumatische Betätigung (Sonderausrüstung) /
 Dispositif d'inversion pour la couture d'étiquettes, entraînement pneumatique (en option) /
 Dispositivo de inversión para costura de etiquetas, mando neumático (opcional)

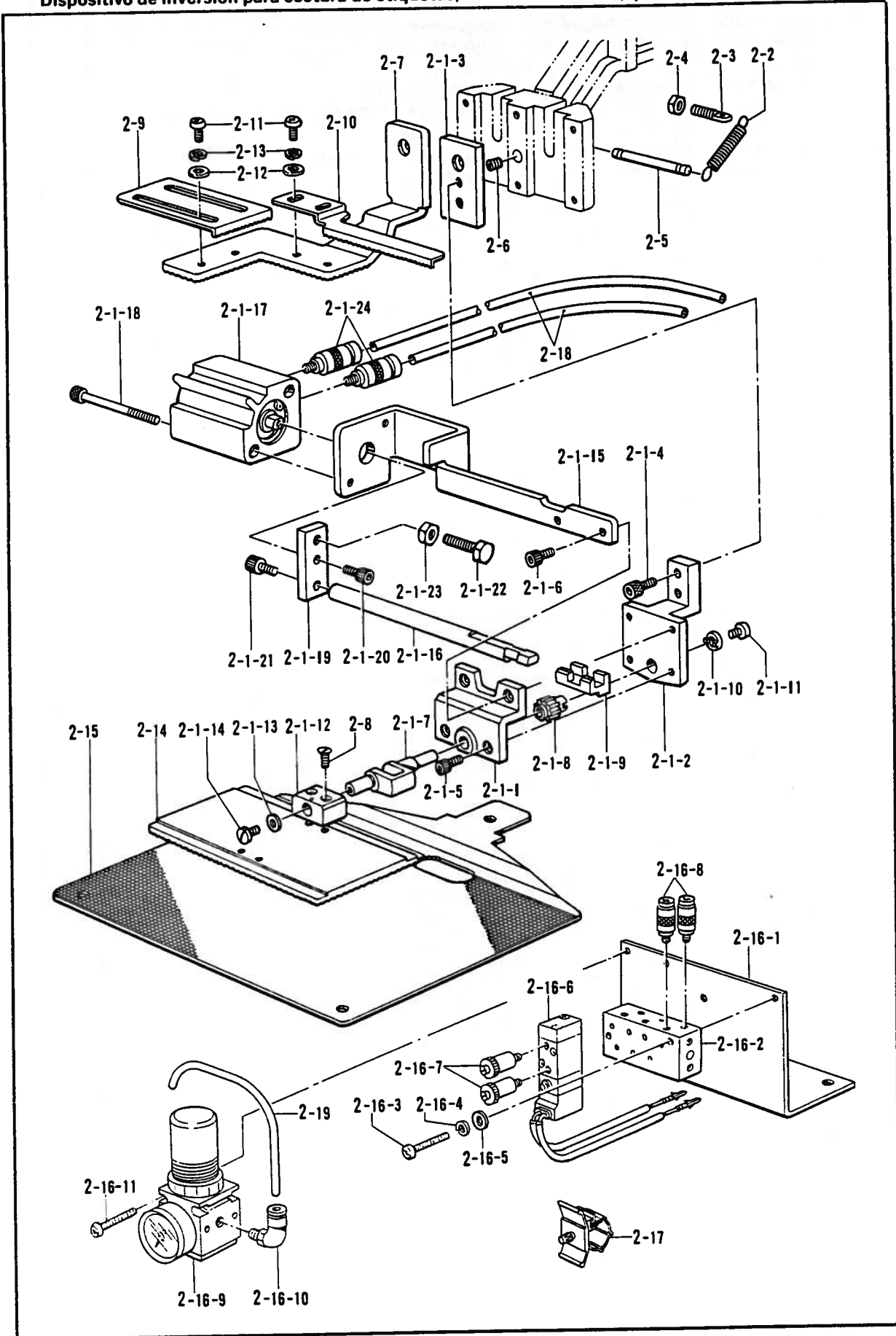

X2. ネーム付反転装置 エアー仕機 / Reversing device for label sewing, pneumatic drive (option) /
 Umkehrvorrichtung zum Etikettannähen, pneumatische Betätigung (Sonderausrüstung) /
 Dispositif d'inversion pour la couture d'étiquettes, entraînement pneumatique (en option) /
 Dispositivo de inversión para costura de etiquetas, mando neumático (opcional)

REF.NO.	CODE	Q'TY	ヒンメイ	NAME OF PARTS	RMKS
2	S15522209	1	ネームツクハンデンソウチセット	-----	
2	S15522210	1	-----	INNER CLAMP DEVICE SET	
2-1	S15180009	1	オサエ克蘭ク180LAクミ	PRESSER CRANK (180LA) ASSY	
2-1-1	S12634009	1	オサエ克蘭クホルタ"A	PRESSER CRANK HOLDER (A)	
2-1-2	S05613009	1	オサエ克蘭クホルタ"B	PRESSER CRANK HOLDER (B)	
2-1-3	S05614001	1	オサエ克蘭クホルタ"C	PRESSER CRANK HOLDER (C)	
2-1-4	018680822	2	アナホ"ルト4.37X8	BOLT 4.37X8	
2-1-5	018301032	2	アナホ"ルト3X10	BOLT M3X10	
2-1-6	018301222	2	アナホ"ルト3X12	BOLT 3X12	
2-1-7	S05665001	1	オサエ克蘭クLA	PRESSER CRANK (LA)	
2-1-8	154235001	1	ハンデンキ"ヤ	REVERSE GEAR	
2-1-9	154236001	1	ハンデンラツク	REVERSE RACK	
2-1-10	145087001	1	ハンデンキ"ヤサ"カ"ネ	WASHER	
2-1-11	149831101	1	アタマツキトメネシ"3.18	SET SCREW 3.18	
2-1-12	154237001	1	オサエイタホルタ"L	PRESSER PLATE HOLDER (L)	
2-1-13	025350132	1	ヒラサ"カ"ネシヨウ	PLAIN WASHER	
2-1-14	100242003	1	シメネシ"3.57	SCREW 3.57	
2-1-15	S12638009	1	ハンデンシリンド"タイ	REVERSE SYLINDER BRACKET	
2-1-16	S12637009	1	ハンデンロツト"	REVERSE ROD	
2-1-17	S12639001	1	ハンデンシリンド"	REVERSE CYLINDER	
2-1-18	S12642001	2	アナホ"ルト3X35	BOLT 3X35	
2-1-19	S12640009	1	ハンデンシ"クツキ"テ	JOINT	
2-1-20	018300822	1	アナホ"ルト3X8	BOLT 3X8	
2-1-21	018300822	1	アナホ"ルト3X8	BOLT 3X8	
2-1-22	017501202	1	ホ"ルト 5X12	BOLT 5X12	
2-1-23	021500102	1	ナツト1シユ5	NUT 5	
2-1-24	S18415001	2	ハーフユニオンQ4M5	HALF UNION	
2-2	S05632001	1	レハ"ーヒキハ"ネA	SPRING	
2-3	110251001	1	ヌノオサエウテ"ハ"ネカク	SPRING HOOK	
2-4	021670102	1	ナツト1シユ3.57	NUT 3.57	
2-5	153957001	1	ハ"ネカクヒ"ン	SPRING HOOK PIN	
2-6	014680622	1	アナトメネシ"4.37クホ"ミ	SET SCREW 4.37	
2-7	S05617001	1	ソトオサエアシ	EXTERNAL WORK CLAMP FOOT	
2-8	117291002	2	サラネシ"3.18	SCREW 3.18	
2-9	154252001	1	イチキ"メイトL	POSITIONING PLATE (L)	
2-10	154253001	1	イチキ"メイトR	POSITIONING PLATE (R)	
2-11	062670512	4	ナヘ"ユ357-40X5	SCREW 3.57X5	
2-12	025350332	4	ヒラサ"カ"ネタ"イ3.5	PLAIN WASHER 3.5	
2-13	028350242	4	ハ"ネサ"カ"ネ2-3.5	SPRING WASHER 2-3.5	
2-14	154256101	1	オサエイタブ"ランクA	PRESSER PLATE BRANK (A)	
2-15	S06321001	1	オク"イタブ"ランク322-1	FEED PLATE BLANK 322-1	
2-16	S30619009	1	ハンデンハ"ルフ"3クミ	INNER CLAMP VALVE ASSY	
2-16-1	S31553009	1	ハ"ルフ"トリツケイタ2-3H	VALVE SET PLATE 2-3H	
2-16-2	S05636001	1	エアマニホルト"	AIR MANIFOLD	
2-16-3	062302506	2	ナヘ"ユ3X25	SCREW 3X25	
2-16-4	028030242	2	ハ"ネサ"カ"ネ2-3	SPRING WASHER 2-3	
2-16-5	025030232	2	ヒラサ"カ"ネチュウ3	PLAIN WASHER 3	
2-16-6	S30615009	1	テ"ンシ"ハ"ルフ"Hクミ	AIR VALVE (H) ASSY	
2-16-7	S03792001	2	ハイキシホ"リハ"ン	EXHAUST THROTTLE VALVE	
2-16-8	S18415001	2	ハーフユニオンQ4M5	HALF UNION	
2-16-9	S12647001	1	エアレキ"ユレータ	AIR REGULATOR	
2-16-10	S29704000	2	コンハ"クトエルホ"4-1/8	ELBOW 4-1/8	
2-16-11	062404005	2	ナヘ"ユ4X40	SCREW 4X40	
2-17	150357001	1	コード"クランプ"13	CORD CLAMP (13-L)	
2-18	S08171000	2	エア"ホース4-J	AIR TUBE 4-J (L=1600)	
2-19	S12649000	2	ナイロンチューブ"	NYLON TUBE	

X3. 付属装置セット/Attachment set/Anbausatz/
 Jeu d'accessoires/Juego de fijación

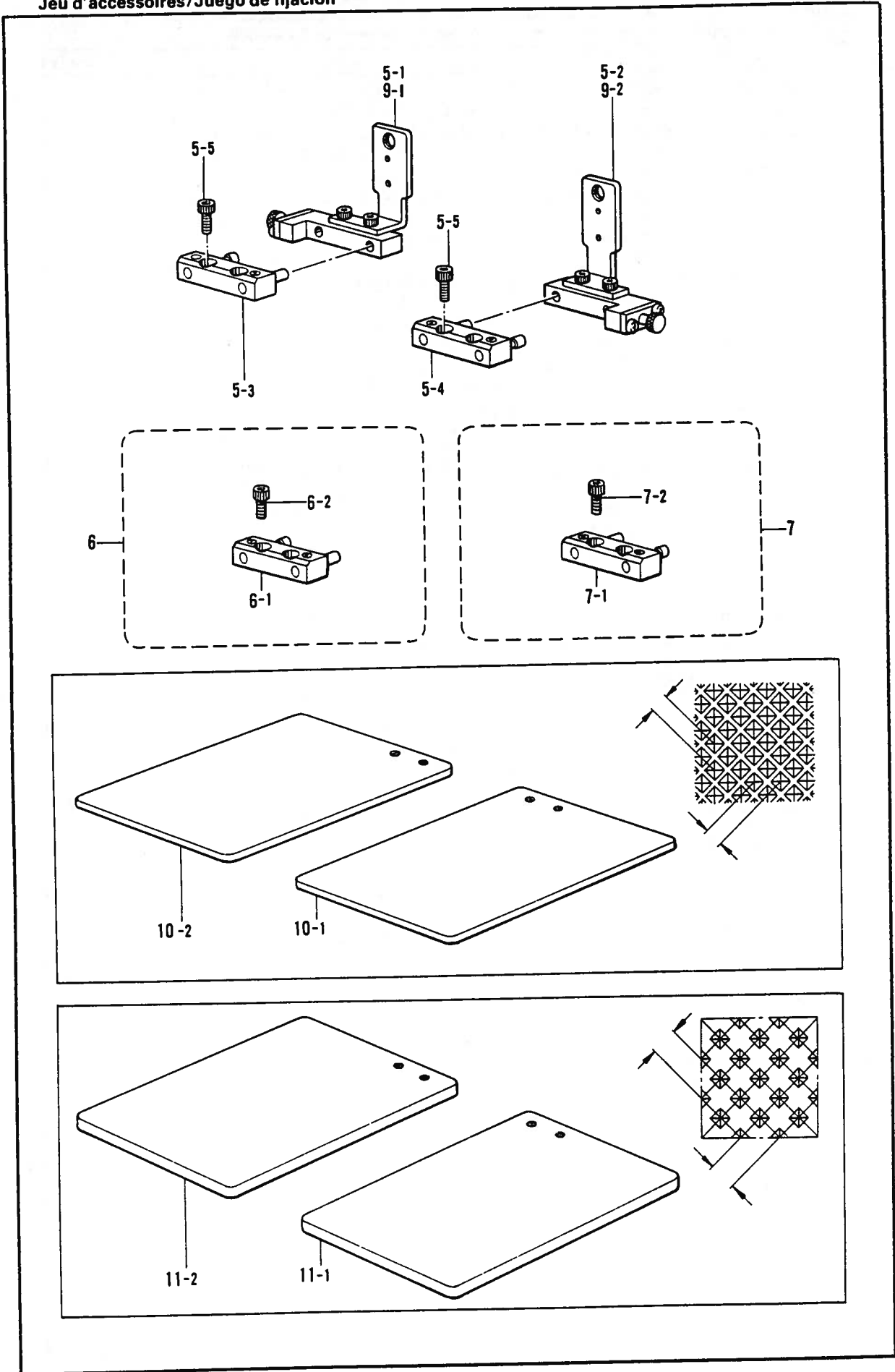

X3. 付属装置セット/Attachment set/Anbausatz/
Jeu d'accessoires/Juego de fijación

REF.NO.	CODE	QTY	品名	NAME OF PARTS	RMKS
5	S20813201	1	ワンタッチオサエソウチセット	ONE-TOUCH WORK CLAMP SET	
5-1	S20777201	1	ワンタッチオサエLクミ	ONE-TOUCH WORK CLAMP (L) ASSY	
5-2	S20776201	1	ワンタッチオサエRクミ	ONE-TOUCH WORK CLAMP (R) ASSY	
5-3	S20289001	2	ジクホルダ"-Lクミ	HOLDER ASSY (L)	
5-4	S20293001	2	ジクホルダ"-Rクミ	HOLDER ASSY (R)	
5-5	018680822	8	アナボ"ルト4.37X8	BOLT 4.37X8	
<ホキウヨウ /FOR SUPPLY>					
6	S20822001	1	ジクホルダ"-Lセット	WORK CLAMP HOLDER SET (L)	
6-1	S20289001	1	ジクホルダ"-Lクミ	HOLDER ASSY (L)	
6-2	018680822	2	アナボ"ルト4.37X8	BOLT 4.37X8	
7	S20823001	1	ジクホルダ"-Rセット	WORK CLAMP HOLDER SET (R)	
7-1	S20293001	1	ジクホルダ"-Rクミ	HOLDER ASSY (R)	
7-2	018680822	2	アナボ"ルト4.37X8	BOLT 4.37X8	
9-1	S20777201	1	ワンタッチオサエLクミ	ONE-TOUCH WORK CLAMP (L) ASSY	
9-2	S20776201	1	ワンタッチオサエRクミ	ONE-TOUCH WORK CLAMP (R) ASSY	
<オプションパーツ /OPTION PARTS>					
<T=3.2 P1>					
10-1	S20780001	1	オサエフ"ランク6-3R	PRESSER BLANK 6-3R	
10-2	S20781001	1	オサエフ"ランク6-3L	PRESSER BLANK 6-3L	
<T=5.0 P1.5>					
11-1	S20782001	1	オサエフ"ランク6-5R	PRESSER BLANK 6-5R	
11-2	S20783001	1	オサエフ"ランク6-5L	PRESSER BLANK 6-5L	

Z. 付属品関係 / Accessories / Zubehör /
Accessoires / Accesorios

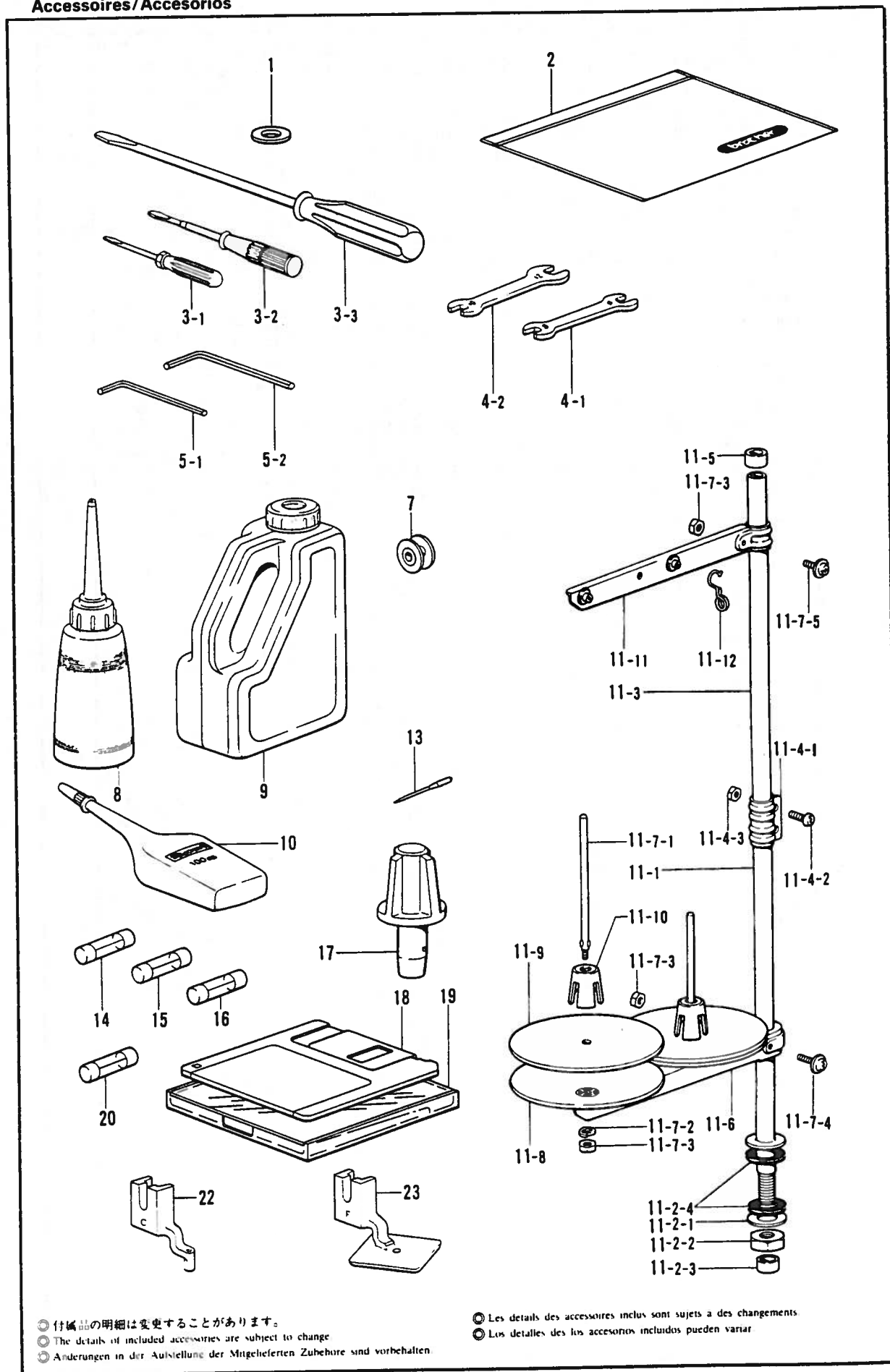

◎ 付属品の明細は変更することがあります。
 ◎ The details of included accessories are subject to change
 ◎ Änderungen in der Aufstellung der Mitgelieferten Zubehöre sind vorbehalten

◎ Les détails des accessoires inclus sont sujets à des changements.
 ◎ Los detalles de los accesorios incluidos pueden variar

Z. 付属品関係/Accessories/Zubehör/
Accessoires/Accessorios

REF NO.	CODE	Q'TY	ヒンメイ	NAME OF PARTS	RMKS
1	S02378001	1	イト"ウハサ"カ"ネT=0.6	WASHER T=0.6	
1	S02378002	1	イト"ウハサ"カ"ネT=0.7	WASHER T=0.7	
1	S07854001	1	イト"ウハサ"カ"ネT=0.8	WASHER T=0.8	
1	S11310001	1	イト"ウハサ"カ"ネT=0.5	WASHER T=0.5	
2	122991001	1	フソクヒンホ"リアクロ	ACCESSORY BAG	
3-1	142443001	1	ネジ"マワシ1.9X52	SCREW DRIVER 1.9X52	
3-2	118837001	1	ネジ"マワシ3.4X70	SCREW DRIVER 3.4X70	
3-3	101572101	1	ネジ"マワシ5.5X190	SCREW DRIVER 5.5X190	
4-1	100887001	1	スハ"ナ8X9	SPANNER 8X9	
4-2	107780001	1	スハ"ナ10X12	SPANNER 10X12	
5-1	142721001	1	6カクホ"ウスハ"ナ3	HEXAGONAL WRENCH 3	
5-2	118064001	1	6カクホ"ウスハ"ナ4	HEXAGONAL WRENCH 4	
7	S15665001	3	ホ"ビ"ンLA	BOBBIN (LA)	
8	114483002	1	ホ"リオイラークミ	OILER ASSY	
9	154702001	1	オイルタンク	OIL TANK	
10	S06706001	1	シリコンオイル	SILICONE OIL	
11	S02763202	1	イトタテタ"イクミ2DR	COTTON STAND ASSY 2DR	
11-1	156112003	1	コラムハ"イフ"D	COLUMN PIPE (D)	
11-2	S02777001	1	ハ"イフ"Dネジ"セットB	PIPE (D) SCREW SET (B)	
11-2-1	150206002	1	ヒラサ"カ"ネ16	PLAIN WASHER 16	
11-2-2	150191002	1	6カクナツ5/8	NUT 5/8	
11-2-3	150174000	1	コラムキャツフ	COLUMN CAP	
11-2-4	S01005000	2	イトタテゴム	RUBBER WASHER	
11-3	150172003	1	コラムハ"イフ	COLUMN PIPE	
11-4	150106003	1	コラムシ"ョイントクミ	COLUMN JOINT ASSY	
11-4-1	150173003	1	コラムシ"ョイント	COLUMN JOINT	
11-4-2	062501406	2	ナヘ"コ5X14	SCREW 5X14	
11-4-3	021500106	2	1シユナツ5	NUT 5	
11-5	150174000	1	コラムキャツフ	COLUMN CAP	
11-6	S02778002	1	スプ"ールホルダ"ー2	SPOOL HOLDER 2	
11-7	S02780001	1	スプ"ールネジ"セット2	SPOOL SCREW SET 2	
11-7-1	150179002	2	スプ"ールシ"クB	SPOOL SHAFT (B)	
11-7-2	028050246	2	ハ"ネサ"カ"ネ2-5	SPRING WASHER 2-5	
11-7-3	021500106	4	1シユナツ5	NUT 5	
11-7-4	050503006	1	ナヘ"コヒラサ"5X30	WASHER SCREW 5X30	
11-7-5	050501406	1	ナヘ"コヒラサ"5X14	WASHER SCREW 5X14	
11-8	150180002	2	ウケサ"ラ	SPOOL STAND BASE	
11-9	150182000	2	スプ"ールマット	SPOOL MAT	
11-10	126863001	2	スプ"ールクツシヨ	SPOOL CUSHION	
11-11	S02786002	1	スレツト"ハンガ"ークミ2	THREAD HANGER ASSY 2	
11-12	S02747101	1	イトカクハ"ネ	SPRING	
13	145646019	4	ミジシハリDPX17(#19)	NEEDLE DPX17 (#19)	
14	S08030000	1	Gヒユース"5AFB	G FUSE (5AFB)	
15	S02887000	1	ヒユース"15A	FUSE (15A)	
16	152565000	1	ヒユース"B	FUSE (B)	
17	S04419009	1	550マクラ	HEAD REST	
18	U42775001	1	3.5メデ"イア 2DD	3.5-MEDIA 2DD	
19	S09989000	1	フロツヒ"ーケース	FLOPPY CASE	
20	152566000	1	ヒユース"C	FUSE (C)	
22	152637001	1	オサエアシC	PRESSER FOOT (C)	
23	157237001	1	オサエアシF	PRESSER FOOT (F)	

オプションパーツ / Optional parts / Sonderzubehör /
 Pieces en option / Piezas opción

オサエアシ / Presser Foot

A	152283-101	B	152636-001	C	152637-001	D	154069-001
E	154089-001	F	157237-001	G	158592-001	J	S13815-001

ハリアナイト / Needle Hole Plate

A	S02371-001	E	S02372-001	F	S02373-001	FH	S10690-001

オサエアシ / Presser Foot

S	S02441-001	M	S02288-001	L	S02469-001	MM	S05667-001

オサエバネ / Spring Plate

1	S02853-001	2	S02854-001	3	S02855-001

カセットオサエ /Cassette Presser

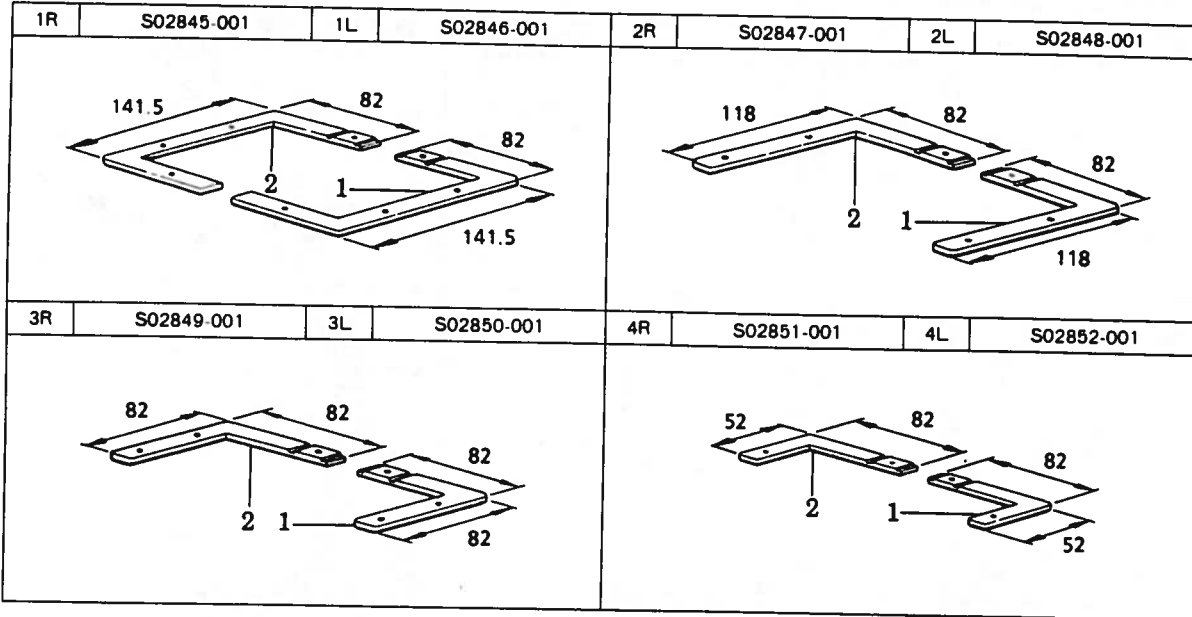

1	カセットイタD-A	Cassette Plate D-A	S02966-101
	カセットイタD-B(180)	Cassette Plate D-B(180)	S14392-101
2	チョウバンクミミギ	Hinge Assy (R)	152632-001
3	チョウバンクミヒダリ	Hinge Assy (L)	152633-001

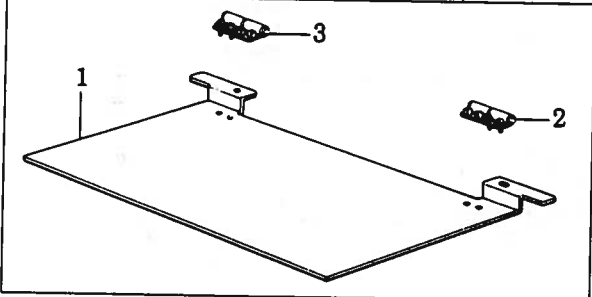

1	カセットシジイタクミ	Cassette Holder Plate Assy	S02963-001
	カセットシジイタクミ180	Cassette Holder Plate Assy180	S14384-001
2	カセットイタD-B	Cassette PlateD-B	S02967-101
	カセットイタD-B180	Cassette Plate D-B180	S14388-001
3	カセットシタイトA	Cassette Plate A	S02969-000
	カセットシタイトB	Cassette Plate B	S02970-000
	カセットシタイトA180	Cassette Plate A180	S14386-000
	カセットシタイトB180	Cassette Plate B180	S14387-000

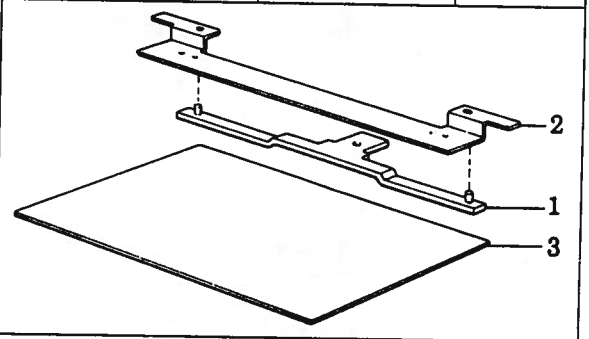

t=1	カセットイタU-A	Cassette Plate U-A	S02968-000
	カセットイタU-A180	Cassette Plate U-A180	S14389-000
t=2	カセットイタU-B	Cassette Plate U-B	S02971-000
	カセットイタU-B180	Cassette Plate U-B180	S14390-000

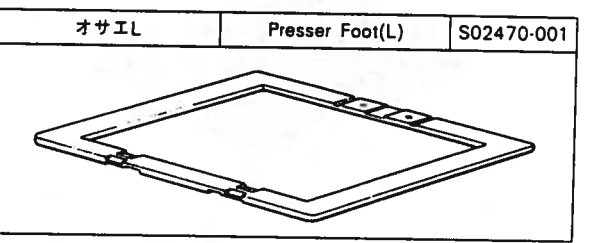
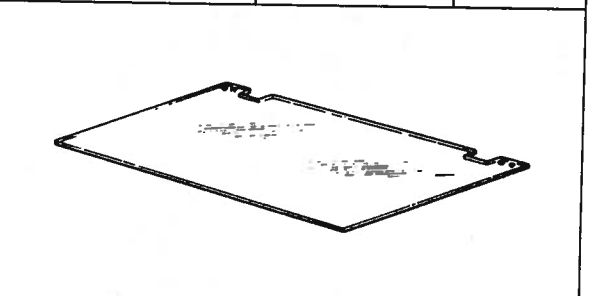

ホジョイタ / Supporting Plate

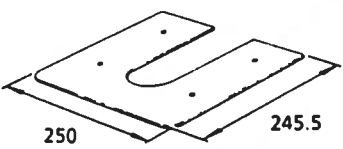
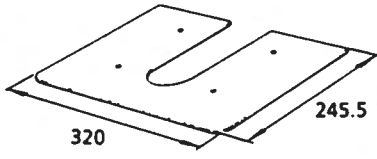
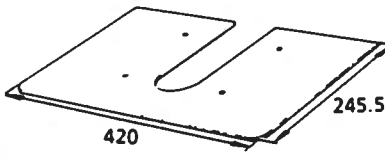
S	S02442-001	L	S02443-001	180	S10682-001
					

OT オサエイタクミ / OP Presser Plate Assy

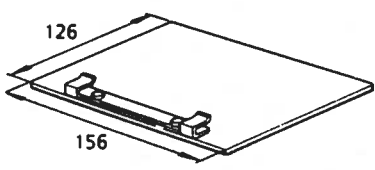
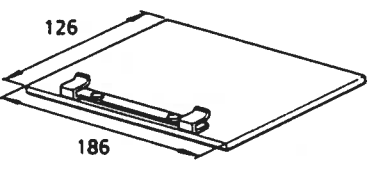
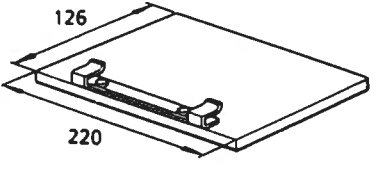
A	S03902-001(t=0.5)	A-150	S09378-001 (t=0.5)	A-180	S13695-001 (t=0.5)
B	S03903-001(t=1)	B-150	S09379-001 (t=1)	B-180	S13697-001 (t=1)
C	S03904-001(t=2)	C-150	S09380-001 (t=2)	C-180	S13698-001 (t=2)
					

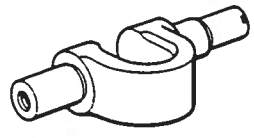
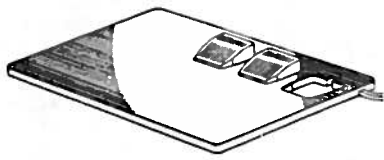
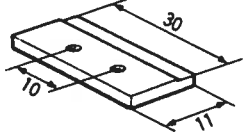
<p>オサエクラク LL Presser Crank LL S10541-001</p> 	<p>フットスイッチイタクミ Foot switch plate (L) Assy S02984-009</p> 	<p>ナカオサエ LL Inner Clamp (LL) S10542-001</p> 
--	--	---

オクリイタブランク / Feed Plate Blank

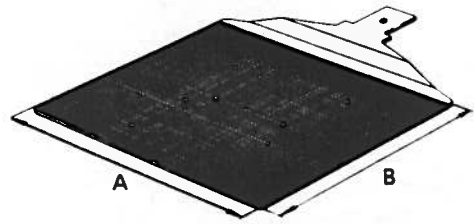
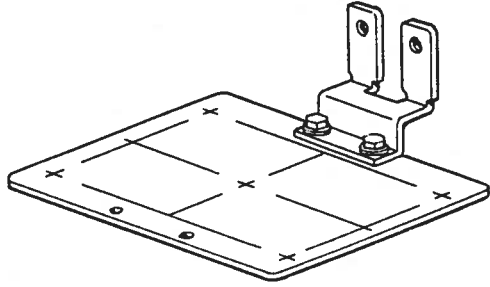
					<p>ゲンテンキジュンイタクミ Home Position Standard Plate Assy S23371-001</p> 	
	板厚 THICK	サイズ SIZE (A×B)	菱目 LOZENGE	部品コード PARTS.NO.		
1	1	170×140	菱目 LOZENGE	S02234-001		
2	2		—	S02843-001		
3	1		—	S02844-001		
4	2	246×163	穴 HOLE	S02842-001		
5				S03309-001		
150	1	200×140	—	S09376-001		
180			S13692-001			

オサエブランク / Presser Blank

		板厚	サイズ	菱目	部品コード
		THICK	SIZE (AxB)	LOZENGE	PARTS.NO.
	B-1R	3.2	39X80	S	153448-000
	B-1L				153449-000
	B-3R	4	39X80	L	153470-000
	B-3L				153471-000
	1-3R	3.2	50X110	S	S02821-000
	1-3L				S02822-000
	1-4R	4	50X110	L	S02823-000
	1-4L				S02824-000
	1-5R	5	50X110	L	S02825-000
	1-5L				S02826-000
	2-3R	3.2	75X135	S	S02827-000
	2-3L				S02828-000
	2-4R	4	75X135	L	S02829-000
	2-4L				S02830-000
	2-5R	5	75X135	L	S02831-000
	2-5L				S02832-000
	150R-3	3.2	90X135	S	S09370-000
	150L-3				S09371-000
	150R-5	5	90X135	L	S09372-000
	150L-5				S09373-000
L-180	3.2	123X135	S	S13694-000	
<p>(ワンタッチ用 / for One touch)</p>	3-3	3.2	100X80	S	S02833-000
	3-4	4		L	S02834-000
	3-5	5		L	S02835-000
	4-3	3.2	125X110	S	S02836-000
	4-4	4		L	S02837-000
	4-5	5		L	S02838-000
	5-3	3.2	150X135	S	S02839-000
	5-4	4		L	S02840-000
	5-5	5		L	S02841-000
	5-3A	3.2		—	S02981-000
	5-4A	4		—	S02982-000
	5-5A	5		—	S02983-000
	150-3	3.2	180X135	S	S09374-000
	150-5	5		L	S09375-000
	180	3.2	216X135	S	S13693-000
	6-3L	3.2	90X135	S	S20781-001
	6-3R				S20780-001
	6-5L	5		L	S20783-001
6-5R	S20782-001				

菱目 / LOZENGE

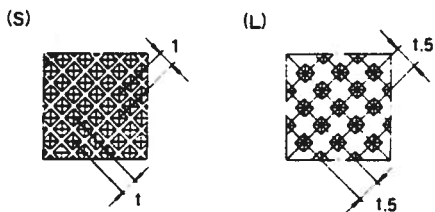

索引/INDEX/VERZEICHNIS/
INDEX/INDICE

CODE	REF.NO.	PAGE
S00470000	P - 43	34
S00554000	R - 1-7	38
S00722001	L - 45	30
S00723001	L - 46	30
S00772001	D2- 39	10
S01005000	Z - 11-2-4	54
S01288003	K - 1-1	26
S01291001	K - 1-14	26
S01292001	K - 1-3	26
S01293001	K - 1-16	26
S01294001	K - 1-7	26
S01825001	U - 1-5	44
S01998001	K - 1-13	26
S02229000	A - 5-2	2
S02231103	A - 10	2
S02237003	B - 15	4
S02239001	H - 6	22
S02242001	A - 20	2
S02255001	F - 53	18
S02258001	C - 2	6
S02260000	C - 3	6
S02263001	C - 13	6
S02265001	C - 24	6
S02267001	C - 24-5	6
S02268001	C - 24-6	6
S02269001	C - 26	6
S02270001	C - 29	6
S02271001	C - 32	6
S02284001	D1- 1-8	8
S02288001	D1- 63	8
S02293001	E - 2	14
S02295000	E - 3-1	14
S02296001	E - 3-2	14
	L - 3-2	28
S02298001	E - 3-4	14
	L - 3-4	28
S02299100	E - 3-5	14
S02300001	E - 60	16
S02301001	E - 3-7	14
S02302001	E - 3-9	14
S02303001	E - 3-17	14
S02307001	E - 11	14
S02309000	E - 16-1	14
S02310001	E - 16-2	14
S02311001	E - 18	14
S02313001	E - 31	14
S02318001	E - 24	14
S02319001	E - 35	14
S02320001	E - 25	14
S02321001	E - 32	14
S02322001	E - 33	14
S02323001	E - 37	14
S02324001	E - 39	14
S02326001	E - 43	14
S02327001	E - 45	16
S02328001	E - 46	16
S02329001	E - 50	16
S02333100	E - 59	16
S02336001	E - 62	16
S02337001	E - 67	16
S02338001	E - 69	16
S02339001	E - 71	16
S02348000	L - 3-1	28
S02350001	L - 3-5-1	28
S02351001	L - 3-11	28
S02352001	L - 8	28
S02353001	L - 19-1	28

CODE	REF.NO.	PAGE
S02353001	L - 8-1	28
S02354001	L - 9	28
S02355001	L - 11	28
	L - 16	28
	L - 23	28
S02356001	L - 13	28
S02357000	L - 14	28
S02358001	L - 19	28
S02359000	B - 35-2	4
S02360001	L - 19-4	28
S02361001	L - 20	28
S02362001	L - 22	28
S02364000	L - 26	28
S02365001	L - 28	28
S02368001	L - 30	28
S02370001	L - 32	28
S02373001	L - 35	28
S02374001	L - 37	28
S02375001	L - 40	28
S02378001	L - 41	28
	Z - 1	54
S02378002	L - 41	30
	Z - 1	54
S02379001	L - 42	30
S02380001	L - 43	30
S02381001	L - 44	30
S02385001	L - 47	30
S02387001	D2- 7	10
S02392001	D2- 23	10
S02396001	D2- 24	10
S02398100	D2- 29	10
S02401000	D2- 31	10
S02403001	D2- 33	10
	F - 21	18
S02404001	F - 23	18
S02405001	D2- 43	10
S02406001	D2- 48	10
S02407009	M - 7	32
S02408101	F - 1	18
S02413001	F - 11	18
S02414001	F - 19	18
S02416001	F - 32	18
S02417001	F - 40	18
S02418001	F - 41	18
S02419001	F - 44	18
S02420001	F - 46	18
S02422001	G - 5	20
S02423101	G - 9	20
S02425001	G - 10	20
S02426001	G - 12	20
S02427101	G - 16	20
S02429001	G - 16-1	20
S02430001	M - 5	32
S02434001	J - 7	24
S02435001	J - 8	24
S02436001	J - 15	24
S02438001	J - 29	24
S02440001	M - 1	32
S02443001	D2- 82	10
S02444001	D2- 60	10
S02445001	B - 118	4
S02446001	C - 22	6
S02447001	E - 63	16
S02448003	K - 1	26
S02449001	K - 1-2	26
S02450001	K - 1-8	26
S02456001	M - 10	32

CODE	REF.NO.	PAGE
S02457001	J - 31	24
S02459001	H - 2-1	22
S02460001	D2- 32	10
S02462001	H - 10-1	22
S02464001	H - 13-1	22
S02465000	H - 13-2	22
S02466100	H - 23	22
S02468001	F - 13	18
	F - 34	18
S02473101	D2- 49	10
S02474001	F - 18	18
S02476001	F - 37	18
S02479001	D2- 53	10
S02483009	B - 96	4
S02484003	A - 29	2
S02485001	E - 74	16
S02684001	N - 1	32
S02685001	N - 2	32
S02687201	N - 7	32
S02739000	V - 1-9	46
S02740000	V - 1-8	46
S02747101	Z - 11-12	54
S02763202	Z - 11	54
S02777001	Z - 11-2	54
S02778002	Z - 11-6	54
S02780001	Z - 11-7	54
S02786002	Z - 11-11	54
S02857001	H - 4-3	22
S02858001	E - 40	14
S02870001	M - 15	32
S02871001	M - 16	32
S02872001	B - 35	4
S02873001	D2- 61	10
S02887000	R - 1-3-6	38
	Z - 15	54
S02917001	P - 2	34
S02939009	W - 1	48
S02940001	W - 1-1	48
S02941001	W - 1-2	48
S02942001	W - 1-3	48
S02943009	W - 1-4	48
S02947001	W - 1-5	48
S02949001	W - 1-6	48
S02950001	W - 1-7	48
S02962001	H - 10-2	22
	H - 2-3	22
S02963001	D2- 75-1	10
S02967101	D2- 77	10
S02969000	D2- 78	10
S02971000	D2- 76-4	10
S02976001	H - 13-6	22
S02977101	U - 1-2	44
S03271001	P - 5	34
S03281001	A - 34	2
S03283000	P - 27	34
S03289001	H - 27	22
S03293001	D2- 20	10
S03294001	D2- 21	10
S03327000	N - 6	32
S03661000	H - 4-4	22
S03662000	H - 2-4	22
S03677001	D2- 18	10
	E - 80	16
S03704001	G - 14	20
S03789001	S - 1-1-5-1	42
	S - 1-2-5-1	42
S03792001	S - 1-1-5-2	42

CODE	REF.NO.	PAGE
S03792001	S - 1-2-5-2	42
	X2- 2-16-7	50
S03797101	D1- 1-14-1	8
	D1- 1-15-1	8
S03799001	D1- 1-16	8
S03800001	D1- 1-17	8
S03801001	D1- 1-19	8
S03802009	D1- 1-1	8
S03805009	D1- 1	8
S03806001	D1- 1-2	8
S03807001	D1- 1-3	8
S03809001	D1- 1-4	8
S03810001	D1- 1-5	8
S03820000	D1- 1-14-2	8
S03861000	Q - 1-1	36
S03864001	Q - 1-8	36
S03866001	Q - 1-11	36
S03867003	Q - 1-14	36
S03899000	D2- 10	10
S03905000	A - 32	2
S04419009	Z - 17	54
S05223001	V - 1-1-1	46
S05613009	X2- 2-1-2	50
S05614001	X2- 2-1-3	50
S05617001	X2- 2-7	50
S05632001	X2- 2-2	50
S05636001	X2- 2-16-2	50
S05665001	X2- 2-1-7	50
S05670002	S - 12-1	42
S06321001	X2- 2-15	50
S06706001	Z - 10	54
S07469001	H - 28	22
S07787001	F - 2-1	18
S07789100	F - 5	18
S07791000	F - 6	18
S07792000	F - 26-1	18
S07793000	F - 39	18
S07794001	F - 49	18
S07795001	B - 51-1	4
S07799001	B - 50-1	4
S07802001	D1- 55-1	8
S07803001	D2- 57-1	10
S07854001	L - 41	30
	Z - 1	54
S07885000	N - 11	32
S08030000	R - 1-3-5	38
	Z - 14	54
S08032000	R - 1-3-1-1	38
S08171000	X2- 2-18	50
S08461001	E - 9	14
S09198003	A - 54	2
S09228000	S - 1-1-4	42
	S - 1-2-4	42
S09231000	S - 1-1-3	42
S09318101	S - 1-1-2	42
	S - 1-2-2	42
S09393002	S - 12-2	42
S09645001	X1- 1	48
S09647001	X1- 1-2	48
S09989000	Z - 19	54
S10025001	B - 123	4
S10112001	E - 79	16
S10240009	P - 1	34
S10264101	V - 1-22	46
S10283001	R - 1-10	38
S10289000	R - 1-15	38
S10315000	R - 1-3-1-2	38

CODE	REF.NO.	PAGE
S10336000	R - 1-14	38
S10355109	V - 1-1	46
S10383001	C - 34	6
S10386100	S - 8	42
S10387100	S - 9	42
S10401001	R - 8-4	40
S10405000	V - 1-13	46
S10408000	R - 10	40
S10463102	S - 14	42
S10465001	R - 1-32	38
S10468000	P - 33	34
S10476001	V - 1-10	46
S10661009	V - 1-1-8	46
S10667001	N - 9	32
S10671001	F - 56	18
S10672001	F - 26-2	18
S10673000	F - 39	18
S10674001	F - 2-2	18
S10676001	F - 2-3	18
S10678100	F - 5	18
S10682001	D2- 80	12
S10683001	D1- 55-2	8
S10684001	D2- 57-2	10
S10685000	B - 51-2	4
S10686000	B - 50-2	4
S10687101	B - 53	4
S10688101	B - 52	4
S11310001	Z - 1	54
S11496009	Q - 1	36
S11497001	Q - 1-7	36
S11498000	Q - 1-10	36
S11500001	Q - 1-22	36
S11687000	Q - 1-4	36
S12634009	X2- 2-1-1	50
S12637009	X2- 2-1-16	50
S12638009	X2- 2-1-15	50
S12639001	X2- 2-1-17	50
S12640009	X2- 2-1-19	50
S12642001	X2- 2-1-18	50
S12647001	X2- 2-16-9	50
S12649000	X2- 2-19	50
S13399001	E - 58	16
S13807000	X1 - 1-3	48
S13818001	X1 - 1-1-1	48
S14384001	D2- 75-2	12
S14386000	D2- 76-2	12
S14388101	D2- 76-1	12
S14390000	D2- 76-3	12
S14432003	A - 13	2
S14433001	C - 1	6
S14434001	C - 6	6
S14436009	C - 10	6
S14438001	N - 5-1	32
S14439001	P - 11	34
S14440001	P - 12	34
S14441001	P - 13	34
S14442009	P - 9	34
S14508000	V - 1-11	46
S14509000	V - 1-12	46
S15078000	S - 10	42
S15079001	D1- 1-14	8
S15080001	D1- 1-15	8
S15138001	C - 4	6
S15139009	A - 27	2
S15140001	D2- 45	10
S15142001	P - 8	34
S15146009	B - 39	4

CODE	REF.NO.	PAGE
S15147101	E - 15	14
S15148001	B - 47	4
S15149003	A - 2	2
S15150001	K - 9	26
S15156001	P - 31	34
S15157001	B - 127	4
S15158009	V - 1-7	46
S15159009	B - 41	4
S15180009	X2- 2-1	50
S15522209	X2- 2	50
S15522210	X2- 2	50
S15663001	G - 24	20
S15665001	G - 27	20
	Z - 7	54
S15667001	G - 26-3	20
S15902101	G - 26	20
S16030001	E - 75	16
S16074001	G - 26-1	20
S16123003	A - 5	2
S16124003	A - 5-1	2
S16254001	E - 76	16
S16492001	G - 26-2	20
S16566000	R - 1-13	38
S16567000	R - 1-18	38
S16568000	R - 2	40
S16575109	R - 8	40
S16578101	R - 8-3	40
S16580000	R - 8-6	40
S16661001	R - 1-9	38
S17053001	P - 14	34
S17741009	Q - 1-16	36
S17868001	D2- 38	10
S17986001	R - 19	40
S17998001	V - 1-21	46
S18101001	R - 8-5	40
S18271009	R - 11	40
S18415001	D1- 1-15-2	8
	S - 1-1-5-3	42
	S - 1-2-5-3	42
	X2- 2-1-24	50
	X2- 2-16-8	50
S18507101	R - 1-1	38
S18573000	R - 1-11	38
S18633109	V - 4	46
S18641009	X1 - 2	48
S18642009	X1 - 2-1	48
S18707149	B - 103	4
S20137001	V - 7	46
S20289001	X3- 5-3	52
	X3- 6-1	52
S20293001	X3- 5-4	52
	X3- 7-1	52
S20776201	X3- 5-2	52
	X3- 9-2	52
S20777201	X3- 5-1	52
	X3- 9-1	52
S20780001	X3- 10-1	52
S20781001	X3- 10-2	52
S20782001	X3- 11-1	52
S20783001	X3- 11-2	52
S20813201	X3- 5	52
S20822001	X3- 6	52
S20823001	X3- 7	52
S21116001	X1 - 1-1-2	48
S21119001	X1 - 1-1	48
S21181000	R - 1-26	38
S21504000	R - 1-26	38

CODE	REF.NO.	PAGE
S21518001	X1 - 1-4	48
S21527001	H - 4-1	22
S21698001	D1- 67-3	8
S21699001	D1- 67-4	8
S21700001	D1- 67-1	8
S21713001	D1- 67	8
S21714001	D1- 67-2	8
S21728001	B - 104	4
S21775001	D1- 1-12	8
S23446000	D2- 41	10
S29007001	T - 1	44
S29008001	T - 2	44
S29009001	R - 1-3	38
S29695001	L - 1	28
S29704000	X2- 2-16-10	50
S29710000	S - 1-2-3	42
S29735101	D2- 30	10
S30175109	R - 1	38
S30206000	T - 2-1	44
S30224000	R - 1-3-3	38
S30227000	R - 1-3-4	38
S30232000	R - 1-20	38
S30233000	R - 1-20	38
S30234000	R - 1-20	38
S30238001	R - 1-29	38
S30249001	R - 1-8	38
S30250001	R - 1-24	38
S30251001	R - 1-27	40
S30253001	T - 6	44
S30254001	T - 7	44
S30264001	R - 1-24	38
S30265109	R - 1	38
S30266109	R - 1	38
S30267109	R - 1	38
S30268109	R - 1	38
S30269109	R - 1	38
S30281001	R - 1-31	38
S30282001	R - 1-8	38
S30285000	R - 1-30	38
S30286000	R - 1-30	38
S30609001	S - 24	42
S30615009	X2- 2-16-6	50
S30616009	S - 1-1	42
S30617001	S - 1-1-5	42
	S - 1-2-5	42
S30618009	S - 1-2	42
S30619009	X2- 2-16	50
S31012001	E - 53	16
S31013001	E - 54	16
S31551009	S - 1-1-1	42
	S - 1-2-1	42
S31553009	X2- 2-16-1	50
S31585001	R - 1-29	38
S31591009	A - 51	2
S31596009	A - 45	2
S31597001	D2- 35	10
S31598001	D2- 36	10
S31599001	D2- 40	10
S31600009	D2- 12	10
S31601009	D2- 13	10
S31602001	D2- 14	10
S31603001	D2- 15	10
S31604001	P - 15-1	34
S31606001	P - 15-2	34
S31608001	B - 22	4
S31645009	V - 1	46
S31646009	V - 1-2	46

CODE	REF.NO.	PAGE
S31648001	P - 30	34
S31650000	R - 1-29-1	38
S31669001	P - 28	34
S32129000	S - 13	42
S32334000	S - 27	42
S32342009	U - 1	44
S32343001	U - 1-1	44
S32344001	U - 1-1-1	44
S32345001	U - 1-1-2	44
S33179001	E - 55	16
T22706000	T - 1-3	44
U31357000	T - 1-1	44
U31359000	T - 1-2	44
U42775001	Z - 18	54
0A4301605	R - 1-4	38
0A5301005	R - 1-25	40
0A5301205	R - 1-16	38
0A5301405	R - 1-12	38
0A5400805	R - 1-28	40
	R - 8-7	40
0A5401005	R - 1-6	38
0A5402005	R - 1-5	38
002301003	P - 3	34
	P - 6	34
002301203	Q - 1-5	36
002400502	Q - 1-20	36
008400604	R - 1-2	38
	R - 8-8	40
011679312	D2- 11	10
013679412	J - 9	24
013760612	J - 22	24
013761412	C - 14	6
014061631	C - 11	6
014680422	D1- 1-12-1	8
014680622	E - 6	14
	G - 3	20
	K - 1-11	26
	K - 10	26
	L - 6	28
	X2- 2-6	50
014760622	B - 16	4
	C - 25	6
	D1- 1-13	8
	D2- 16	10
	D2- 34	10
	D2- 42	10
	E - 14	14
	E - 17	14
	E - 3-10	14
	E - 3-12	14
	E - 3-6	14
	E - 34	14
	E - 47	16
	F - 14	18
	F - 20	18
	F - 22	18
	F - 35	18
	G - 11	20
	G - 17	20
	G - 6	20
	G - 8	20
	J - 17	24
	V - 1-23	46
	X1- 4	48
014770622	C - 19	6
	C - 21	6
	C - 23	6

CODE	REF.NO.	PAGE
014770622	E - 75-1	16
	E - 76-1	16
	G - 14-1	20
	L - 2	28
	L - 3-6	28
017082203	S - 19	42
017501202	X2 - 2-1-22	50
017680512	D1 - 56	8
017681012	D2 - 50	10
017761412	D2 - 8	10
018061036	R - 1-21	40
018061222	B - 111	4
018062022	F - 9	18
018082022	E - 7	14
	L - 7	28
018083022	R - 3	40
018300822	X2 - 2-1-20	50
	X2 - 2-1-21	50
018301032	X2 - 2-1-5	50
018301222	X2 - 2-1-6	50
018400632	F - 50	18
018401022	X1 - 1-1-3	48
018401222	D2 - 26	10
	E - 44	16
018500822	D2 - 17	10
018501022	L - 27	28
	P - 16	34
018501222	D1 - 62	8
018501422	G - 22	20
018501622	E - 70	16
	F - 57	18
018502222	P - 19	34
	F - 27	18
018502522	F - 7	18
	F - 30	18
018680822	M - 2	32
	X2 - 2-1-4	50
018681022	X3 - 5-5	52
	X3 - 6-2	52
	X3 - 7-2	52
	B - 126	4
	D2 - 22	10
021060102	F - 3	18
	F - 42	18
	L - 12	28
	L - 17	28
	L - 24	28
021060106	B - 109	4
021080106	V - 1-19	46
021120304	S - 23	42
021300103	V - 1-1-4	46
021300206	Q - 1-6	36
021500102	R - 1-17	38
021500103	X2 - 2-1-23	50
	A - 35	2
021500106	S - 5	42
	Z - 11-4-3	54
021670102	Z - 11-7-3	54
	X2 - 2-4	50
021750102	E - 30	14
021860312	E - 61	16
021910302	E - 23	14
025030232	F - 55	18
	S - 1-1-8	42
025030233	S - 1-2-8	42
	X2 - 2-16-5	50
	P - 7	34

CODE	REF.NO.	PAGE
025040232	D2 - 28	10
	F - 51	18
	V - 9	46
	X1 - 1-1-5	48
025050232	D2 - 51	10
	F - 29	18
	F - 59	18
	P - 18	34
	P - 21	34
025050233	S - 3	42
	A - 36	2
025050236	V - 1-1-7	46
025060132	D2 - 9	10
025060232	B - 112	4
	L - 50	30
025060236	R - 1-22	40
025060332	B - 110	4
025060336	V - 1-17	46
025080132	K - 1-5	26
025080232	E - 8	14
	R - 4	40
025080336	S - 21	42
	S - 22	42
025100132	B - 25	4
025350132	D2 - 46	10
	L - 38	28
025350236	X2 - 2-1-13	50
	B - 119	4
025350332	H - 13-4	22
	X2 - 2-12	50
025680132	A - 53	2
025680232	M - 9	32
	C - 9	6
025710232	D1 - 1-6	8
	D2 - 59	10
025750132	B - 42	4
025770232	B - 46	4
	E - 3-19	14
026120236	L - 3-12	28
	V - 1-1-2	46
028030242	Q - 1-13	36
	Q - 1-18	36
028040232	Q - 1-3	36
	S - 1-1-7	42
028040242	S - 1-2-7	42
	X2 - 2-16-4	50
028050242	X1 - 1-1-4	48
028050242	D2 - 27	10
	F - 52	18
028050242	Q - 1-21	36
	E - 73	16
028050246	F - 28	18
	F - 58	18
028060242	F - 8	18
	P - 17	34
028060242	P - 20	34
	S - 4	42
028060242	V - 1-1-9	46
	Z - 11-7-2	54
028060242	F - 10	18
	L - 51	30
028080242	R - 1-23	40
	V - 1-18	46
028120246	R - 5	40
	S - 20	42
028350242	V - 1-1-3	46
	X2 - 2-13	50

CODE	REF.NO.	PAGE
028680242	F - 48	18
028770242	E - 3-20	14
	L - 3-13	28
031312006	U - 1-6	44
032361306	V - 1-6	46
032422003	V - 5	46
032461606	P - 41	34
034311302	U - 1-3	44
037521016	V - 1-1-6	46
047201042	E - 3-21	14
047251640	H - 26	22
047503242	A - 3	2
048025342	M - 6	32
048030342	M - 11	32
048040342	D1- 1-18	8
	E - 19	14
	E - 52	16
	E - 66	16
048050342	K - 1-15	26
	L - 29	28
048060342	D1- 1-9	8
	E - 3-13	14
	F - 12	18
	F - 33	18
	K - 1-6	26
	L - 3-7	28
048080342	B - 24	4
	E - 13	14
	E - 49	16
	G - 20	20
	C - 17	6
048150142	D2- 37	10
048220242	Z - 11-7-5	54
050501406	Z - 11-7-4	54
050503006	P - 23	34
060400816	P - 25	34
061302506	W - 1-8	48
062300416	F - 54	18
062300612	P - 10	34
	Q - 1-12	36
	Q - 1-17	36
	Q - 1-9	36
062300806	F - 38	18
062301016	Q - 1-2	36
062302506	S - 1-1-6	42
	S - 1-2-6	42
	X2- 2-16-3	50
062401012	Q - 1-15	36
062404005	X2- 2-16-11	50
062501202	S - 2	42
062501406	Z - 11-4-2	54
062630712	N - 8	32
062660412	G - 16-2	20
062660712	G - 16-6	20
062670412	J - 25	24
	L - 39	28
062670512	B - 36	4
	X2- 2-11	50
062670612	A - 30	2
	B - 54	4
	H - 13-3	22
	H - 20	22
	H - 25	22
	J - 28	24
	J - 4	24
	N - 13	32
062670812	A - 9	2

CODE	REF.NO.	PAGE
062670812	D2- 47	10
	Q - 2	36
062671012	M - 4	32
062680512	M - 8	32
062680612	A - 52	2
	D1- 1-7	8
	H - 5	22
062680812	B - 55	4
	C - 24-7	6
	F - 47	18
	H - 11	22
	H - 14	22
	H - 3	22
	K - 1-4	26
062681012	C - 33	6
062681212	E - 40-1	14
062681412	C - 8	6
062681612	N - 4	32
062710612	B - 120	4
	B - 19	4
	B - 43	4
	B - 97	4
062711012	A - 14	2
	A - 55	2
	D2- 44	10
	F - 45	18
	J - 2	24
	K - 2	26
	P - 29	34
062711212	E - 72	16
	P - 26	34
062711412	A - 46	2
	A - 6	2
	B - 121	4
	B - 122	4
062711612	E - 26	14
062751612	E - 36	14
062761012	D2- 54	10
	L - 21	28
062761412	A - 4	2
	L - 31	28
062762012	L - 15	28
072068980	F - 15	18
	F - 36	18
081001670	E - 65	16
081003670	G - 13	20
	G - 19	20
081007670	F - 25	18
081014070	F - 24	18
100032004	D2- 85	10
	L - 34	28
100136001	J - 14	24
	J - 35	24
	K - 13	26
100197002	D1- 1-10	8
100242003	D1- 67-5	8
	X2- 2-1-14	50
100250001	C - 18	6
100257010	B - 98	4
	D1- 67-6	8
100360003	L - 36	28
100645003	B - 125	4
	N - 3	32
100666002	B - 45	4
100887001	Z - 4-1	54
101073001	V - 1-4	46
101121003	V - 1-5	46

CODE	REF.NO.	PAGE
101572101	Z - 3-3	54
101706001	C - 20	6
101795001	X1 - 5	48
102538007	B - 35-3	4
102843004	C - 7	6
104449009	A - 16	2
104450109	A - 37	2
104567001	H - 9	22
104689002	G - 2	20
105234003	L - 3-5-3	28
106129001	B - 35-4	4
107017002	R - 8-2	40
107038003	D1- 66	8
	D1- 67-7	8
107149001	H - 21	22
107231002	B - 124	4
107321003	R - 8-1	40
107407003	N - 10	32
107415009	C - 30	6
107415011	C - 30	6
107415014	C - 30	6
107415016	C - 30	6
107415018	C - 30	6
107415021	C - 30	6
107415023	C - 30	6
107453001	E - 29	14
107606001	J - 13	24
107780001	Z - 4-2	54
109239002	A - 12	2
110168001	D1- 1-20	8
110201001	E - 3-3	14
	L - 3-3	28
110251001	X2- 2-3	50
110367001	E - 3-14	14
	L - 3-8	28
110505001	E - 12	14
111466101	E - 57	16
112669001	H - 18	22
112751003	J - 6	24
113316001	J - 5	24
113745001	A - 11	2
114294001	J - 16	24
114483002	Z - 8	54
114486002	B - 18	4
115186001	J - 32	24
115188001	J - 34	24
	K - 12	26
115947001	B - 108	4
116662003	V - 6	46
116920001	C - 16	6
117291002	X2- 2-8	50
117934009	A - 7	2
117936009	A - 18	2
118064001	Z - 5-2	54
118735001	M - 12	32
118764002	K - 7	26
118837001	Z - 3-2	54
119702004	V - 1-3	46
120448001	K - 1-10	26
122991001	Z - 2	54
126863001	Z - 11-10	54
132051001	C - 24-4	6
133172003	V - 1-1-5	46
133740006	V - 1-16	46
138444001	V - 8	46
140392009	A - 19	2
140726000	C - 12	6

CODE	REF.NO.	PAGE
141275001	C - 5	6
141492001	L - 19-2	28
	L - 8-2	28
141494001	L - 18	28
	L - 25	28
141786001	G - 1	20
141808001	G - 25	20
142211001	C - 31	6
142329000	H - 16	22
142443001	Z - 3-1	54
142628001	E - 48	16
142721001	Z - 5-1	54
143591001	D1- 1-11	8
144458001	C - 27	6
144505000	K - 3	26
144588001	J - 10	24
144712001	C - 2-1	6
145087001	X2- 2-1-10	50
145446001	J - 11	24
	J - 33	24
	K - 11	26
145472001	E - 56	16
145478001	E - 68	16
145595001	Q - 1-19	36
145646014	C - 30	6
145646016	C - 30	6
145646018	C - 30	6
145646019	C - 30	6
	Z - 13	54
145646021	C - 30	6
145646024	C - 30	6
145646025	C - 30	6
145992001	M - 14	32
146086001	M - 3	32
146198001	K - 6	26
146199001	K - 5	26
146200001	K - 4	26
146255000	V - 1-15	46
146256001	V - 1-14	46
146373000	H - 15	22
146375000	H - 10-3	22
146597101	D2- 52	10
147402001	M - 13	32
149547000	N - 12	32
	P - 24	34
	S - 6	42
149796001	X2- 2-1-11	50
149831101	B - 44	4
149853001	Z - 11-4	54
150106003	Z - 11-3	54
150172003	Z - 11-4-1	54
150173003	Z - 11-2-3	54
150174000	Z - 11-5	54
	Z - 11-7-1	54
150179002	Z - 11-8	54
150180002	Z - 11-9	54
150182000	Z - 11-2-2	54
150191002	Z - 11-2-1	54
150206002	X2- 2-17	50
150357001	E - 38	14
150451001	E - 27	14
150460001	E - 28	14
150461001	E - 51	16
	E - 41	14
150467001	E - 42	14
150468001	L - 10	28
150553001	L - 19-3	28

CODE	REF.NO.	PAGE
150553001	L - 8-3	28
150756009	E - 10	14
151602002	M - 17	32
151603002	E - 64	16
152231000	C - 15	6
152236001	C - 24-2	6
152237001	C - 24-3	6
152242001	C - 28	6
152245001	G - 4	20
152247001	G - 7	20
152283101	E - 77	16
152510000	R - 1-19	40
152565000	R - 1-3-7	38
	Z - 16	54
152566000	R - 1-3-8	38
	Z - 20	54
152632001	D2- 79-1	10
152633001	D2- 79-2	10
152637001	Z - 22	54
152678001	G - 18	20
152681201	G - 21	20
152683001	G - 16-3	20
152684101	G - 16-4	20
152686001	G - 23	20
152753001	E - 3-8	14
152841109	A - 8	2
152860009	B - 27	4
152869001	J - 1	24
152870001	J - 3	24
152881001	J - 21	24
152883000	J - 23	24
152884001	J - 24	24
152889001	J - 27	24
152891001	J - 30	24
152948001	H - 1	22
	H - 12	22
152952001	H - 2-2	22
152955001	H - 4-2	22
152963001	H - 13-5	22
	H - 17	22
152969001	H - 19	22
	H - 24	22
153043001	E - 3-11	14
153102001	B - 35-1	4
153208002	A - 21	2
	A - 33	2
	D2- 25	10
	L - 33	28
153330001	C - 24-1	6
153369001	D1- 64	8
153370001	D1- 65	8
153403002	D2- 58	10
153843009	X1- 3	48
153957001	X2- 2-5	50
154235001	X2- 2-1-8	50
154236001	X2- 2-1-9	50
154237001	X2- 2-1-12	50
154252001	X2- 2-9	50
154253001	X2- 2-10	50
154256101	X2- 2-14	50
154465001	B - 17	4
154528001	K - 1-9	26
154590001	L - 3-5-2	28
154594000	E - 3-16	14
	L - 3-10	28
154595001	E - 3-18	14
154596000	E - 3-15	14

CODE	REF.NO.	PAGE
154596000	L - 3-9	28
154599000	E - 4	14
	L - 4	28
154600001	E - 5	14
	L - 5	28
154702001	Z - 9	54
154763010	C - 30	6
155489000	H - 22	22
156112003	Z - 11-1	54
157237001	Z - 23	54
157704001	P - 4	34
158581000	P - 42	34
158827000	B - 107	4
158831001	B - 23	4
158832000	B - 26	4
159119101	E - 22	14
159150009	U - 1-4	44
	V - 2	46
159224001	J - 26	24
159253001	K - 1-12	26
159256001	K - 8	26
159805001	J - 12	24
200190001	S - 15	42
	V - 1-20	46
	V - 3	46
228475000	N - 5-2	32
237943001	N - 5	32
238033001	N - 5-3	32
340400001	P - 34	34
	P - 40	34
	R - 18	40
	S - 25	42
402887001	G - 16-5	20
525664000	P - 22	34
525907000	P - 35	34

