

# brother

## BAS-46

### *Boutique*

**COMPACT COMPUTERIZED MONOGRAMMING MACHINE**

**COMPAKTER ELEKTRONIK-MONOGRAMM-STICKAUTOMAT**

**AUTOMATE COMPACT POUR MONOGRAMMES**

**COMPACTA COMPUTADORIZADA MAQUINA DE MONOGRAMMA**

**PARTS BOOK**

**TEILEKATALOG**

**LIVRE DES PIECES**

**LIBRO DE REFERENCIA DE PIEZAS**



## Notes for using this parts book

1. Parts supplied as complete assemblies are circled by a dotted line (.....).
2. This book was prepared based on information available in March 1989.
3. Parts are subject to changes in design without prior notice.

## CONTENTS

A. Machine body .....	2	N. Thread breakage detector mechanism .....	16
B. Display and indicators .....	4	P. Power supply equipment (I) .....	18
C. Upper shaft mechanism .....	4	Q. Feed guide mechanism (1) .....	20
D. Needle bar mechanism .....	6	Q. Feed guide mechanism (2) .....	22
E. Thread take-up mechanism .....	8	R. Upper threading mechanism .....	24
F. Presser foot mechanism (I) .....	8	S. Programmer device .....	24
G. Rotary hook drive assembly .....	10	T. Power table mechanism .....	26
H. Rotary hook mechanism .....	12	U. Power supply equipment (II) .....	28
J. Bobbin winder mechanism .....	12	V. Option parts .....	30
K. Threading mechanism .....	14	Z. Accessories .....	32
L. Presser foot mechanism (II) .....	14	FLOPPY LIST .....	33
M. Motor mechanism .....	16	INDEX .....	34

## Anmerkungen zum Gebrauch dieses Teileliste

1. Die Teile, die als kompletter Satz geliefert werden, sind mit einer gestrichelten Linie umrandet.
2. Dieses Buch basiert auf den Informationen vom März 1989.
3. Modelländerungen sind vorbehalten.

## INHALTSVERZEICHNIS

A. Maschinengehäuse .....	2	N. Fadenbruchfühler .....	16
B. Anaeige und Anzeigeleuchten .....	4	P. Stromversorgung (I) .....	18
C. Obere welle .....	4	Q. Transportführung (1) .....	20
D. Nadelstange .....	6	Q. Transportführung (2) .....	22
E. Fadenabnahmevorrichtung .....	8	R. Oberer fadens .....	24
F. Stoffdrückerfuß (I) .....	8	S. Programmvorrichtung .....	24
G. Greife rantrieb .....	10	T. Motorgestell .....	26
H. Greifervorrichtung .....	12	U. Stromversorgung (II) .....	28
J. Spuler .....	12	V. Sonderzubehör .....	30
K. Fadenführungsvorrichtung .....	14	Z. Zubehör .....	32
L. Stoffdrückerfuß (II) .....	14	Diskettenliste .....	33
M. Motor .....	16	VERZEICHNIS .....	34

## Notes sur l'utilisation de ce manuel de pièces détachées

1. Les pièces fournies en tant qu'assemblages complets sont encadrées avec un trait pointillé (---).
2. Ce manuel a été fait d'après les renseignements valables au mois de Mars 1989.
3. Les pièces peuvent être sujettes à des modifications sans préavis.

## TABLE DES MATIERES

A. Corps de la machine .....	2	P. Mécanisme de léquipement en alimentation electrique (I) .....	18
B. Affichage et témoins .....	4	Q. Mécanisme du guide de lentraînemnt (1) .....	20
C. Mécanisme de lárbre supérieur .....	4	Q. Mécanisme du guide de lentraînemnt (2) .....	22
D. Mécanisme de la barre à aiguille .....	6	R. Mécanisme de lénfilage supérieur .....	24
E. Releveur de fil .....	8	S. Dispositif du programmeur .....	24
F. Mécanisme du pied presseur (I) .....	8	T. Mécanisme du plateau de la machine .....	26
G. Entraînement du crochet rotatif .....	10	U. Mécanisme de léquipement en alimentation electrique (II) .....	28
H. Mécanisme du crochet rotatif .....	12	V. Pièces en option .....	30
J. Mécanisme de bobineur .....	12	Z. Accessoires .....	32
K. Mécanisme de lénfilage .....	14	Liste de disquette .....	33
L. Mécanisme du pied presseur (II) .....	14	INDEX .....	34
M. Mécanisme du moteur .....	16		
N. Mécanisme du détecteur de cassure du fil .....	16		

## Notas para usar este Libro de Piezas

1. Las piezas suministradas como conjuntos completos se enmarcan con una línea punteada .
2. Este libro ha sido compilado basándose en los datos de que se disponía en marzo 1989.
3. Las piezas quedan sujetas a cambios de diseño sin aviso previo.

## INDICE

A. Cuerpo de la máquina .....	2	P. Mecanismo de la equipo de alimentación	
B. Rantalla de exhibición e indicadores .....	4	de corriente (I) .....	18
C. Mecanismo de la eje superior .....	4	Q. Mecanismo de la guía de alimentación (1) .....	20
D. Mecanismo de la barra de aguja .....	6	Q. Mecanismo de la guía de alimentación (2) .....	22
E. Mecanismo del tirahílas .....	8	R. Mecanismo de le enhebrado superior .....	24
F. Mecanismo del prensateras (I) .....	8	S. Programadora .....	24
G. Conjunto de mando del congrejo .....	10	T. Mecanismo del mesa de la máquina .....	26
H. Mecanismo del cangrejo .....	12	U. Mecanismo de la equipo de alimentación	
J. Mecanismo del devanador de la canilla .....	12	de corriente (II) .....	28
K. Mecanismo de la enhebrado .....	14	V. Piezas opción .....	30
L. Mecanismo del prensateras (II) .....	14	Z. Accesorios .....	32
M. Mecanismo del caja de controles .....	16	Lista de discos flexibles .....	33
N. Mecanismo del sensor de cortes en el hilo .....	16	INDICE .....	34

A. Machine body/Maschinengehäuse/Corps de la machine/Cuerpo de la máquina

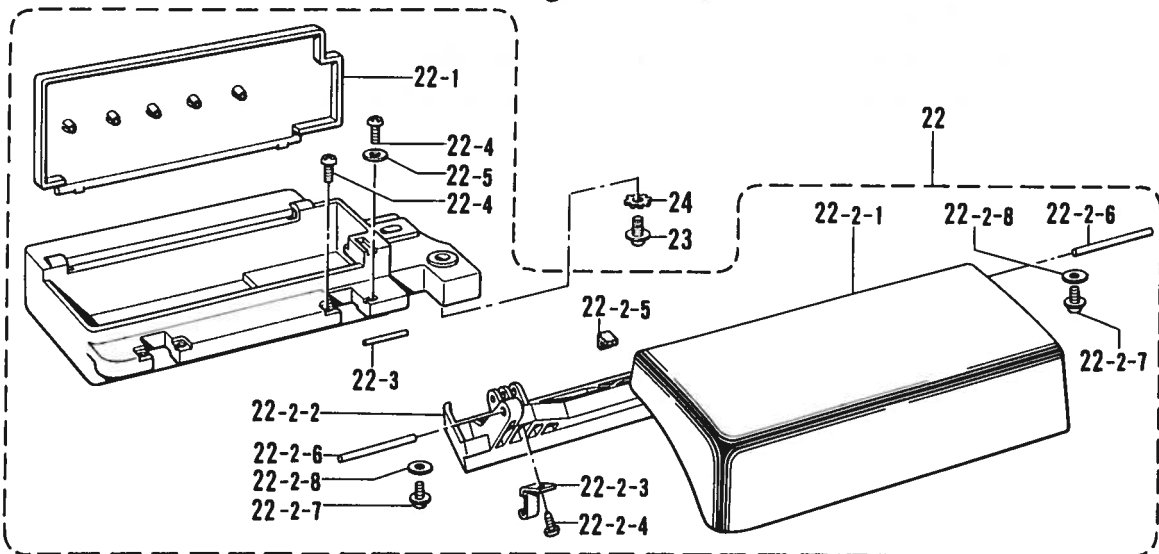
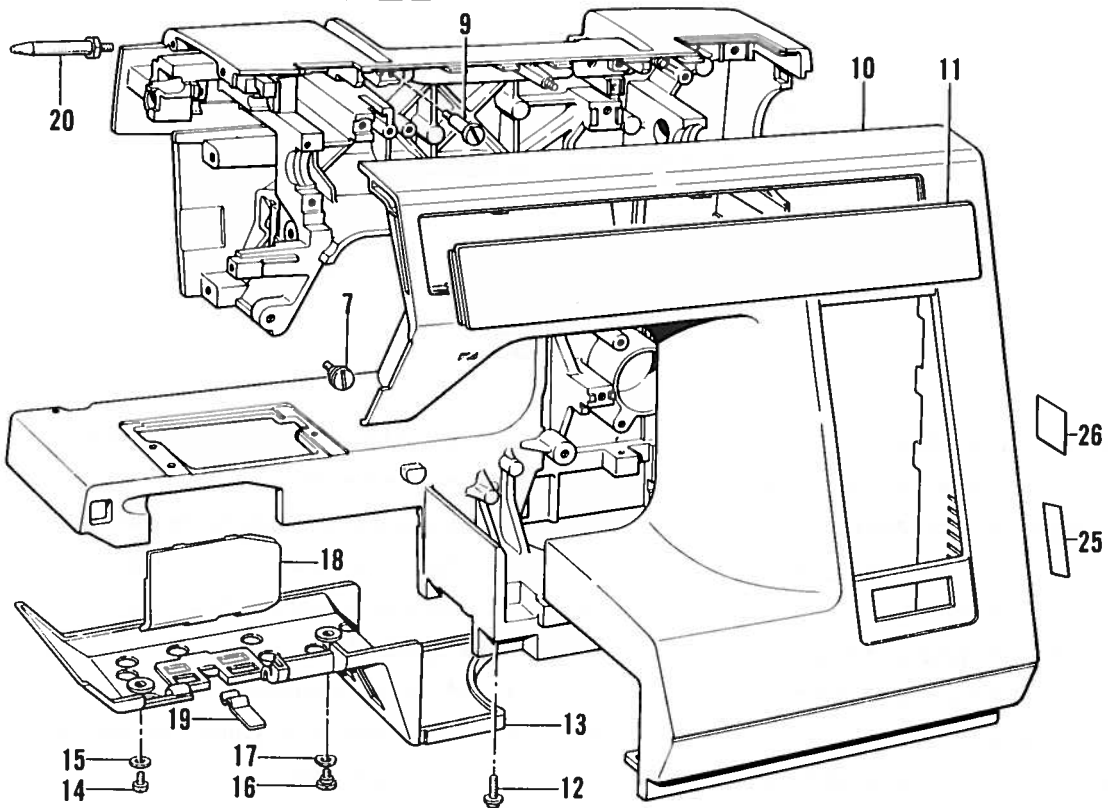
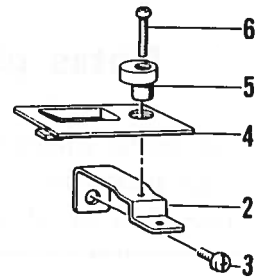
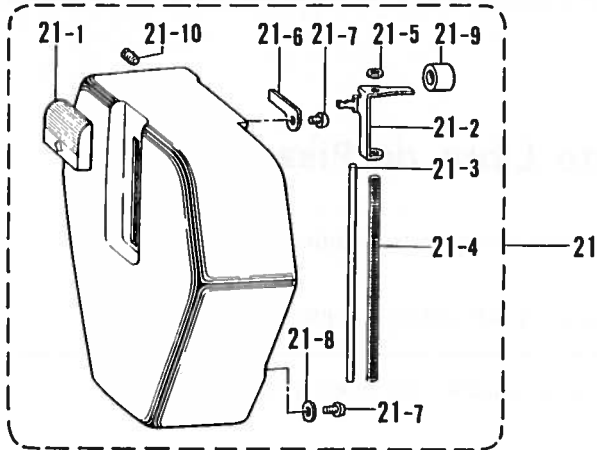

A. Machine body/Maschinengehäuse/Corps de la machine/Cuerpo de la máquina

REF.NO.	CODE	Q'TY	NAME OF PARTS	RMKS
2	132231001	1	BOBBIN WINDER PRESSER COLLAR PLATE	
3	060400616	1	SCREW M4X6	
4	132232002	1	BOBBIN WINDER COVER	
5	S09744001	1	BOBBIN PRESSER	
6	062301616	1	SCREW M3X16	
7	136535001	3	STUD SCREW	
9	136611001	1	STUD SCREW 3	
10	S09722001	1	FRONT COVER	
11	S09727001	1	TRANSPARENT PLATE	
12	135525001	2	SCREW M3X10	
13	136507001	1	BED COVER	
14	060300806	1	SCREW M3X8	
15	130128001	1	WASHER	
16	523323001	1	STUD SCREW	
17	117851001	1	SPRING WASHER	
18	137272001	1	ROTARY HOOK COVER	
19	132257001	1	PLATE SPRING	
20	132253001	1	FACE PLATE GUIDE PIN (B)	
21	136503003	1	FACE PLATE ASSEMBLY	
21-1	130146003	1	THREADING LEVER THUMB	
21-2	136813001	1	THREADING LEVER	
21-3	129825001	1	NEEDLE THREADING LEVER SHAFT	
21-4	129826001	1	NEEDLE THREADING LEVER SPRING	
21-5	129935000	1	RUBBER WASHER	
21-6	129983001	1	LEVER SHAFT PRESSER	
21-7	136681001	2	SCREW 3X8	
21-8	513159001	1	WASHER	
21-9	136505001	1	COLLAR	
21-10	013400814	1	SET SCREW M4X8	
22	S09723001	1	AUXILIARY FOOT ASSEMBLY	
22-1	132259002	1	AUXILIARY FOOT COVER	
22-2	136511005	1	AUXILIARY TABLE ASSEMBLY	
22-2-1	136512005	1	AUXILIARY TABLE (UPPER)	
22-2-2	136513001	1	AUXILIARY TABLE (LOWER)	
22-2-3	136514001	1	PLATE SPRING	
22-2-4	136681001	1	SCREW 3X8	
22-2-5	136516001	1	TABLE STOP RUBBER	
22-2-6	136515001	2	HINGE PIN	
22-2-7	136869001	2	SCREW B3X6	
22-2-8	025030336	2	WASHER 3	
22-3	132881001	2	HINGE PIN	
22-4	060300616	4	SCREW M3X6	
22-5	025040133	2	PLAIN WASHER 4	
23	060601216	2	SCREW M6X12	
24	115000000	2	TOOTHED WASHER	
25	S09746000	1	MASK TAPE (A)	
26	S09747000	1	MASK TAPE (B)	

**B. Display and indicators / Anaeige und Anzeigeleuchten /  
Affichage et témoins / Rantalla de exhibición e indicadores**

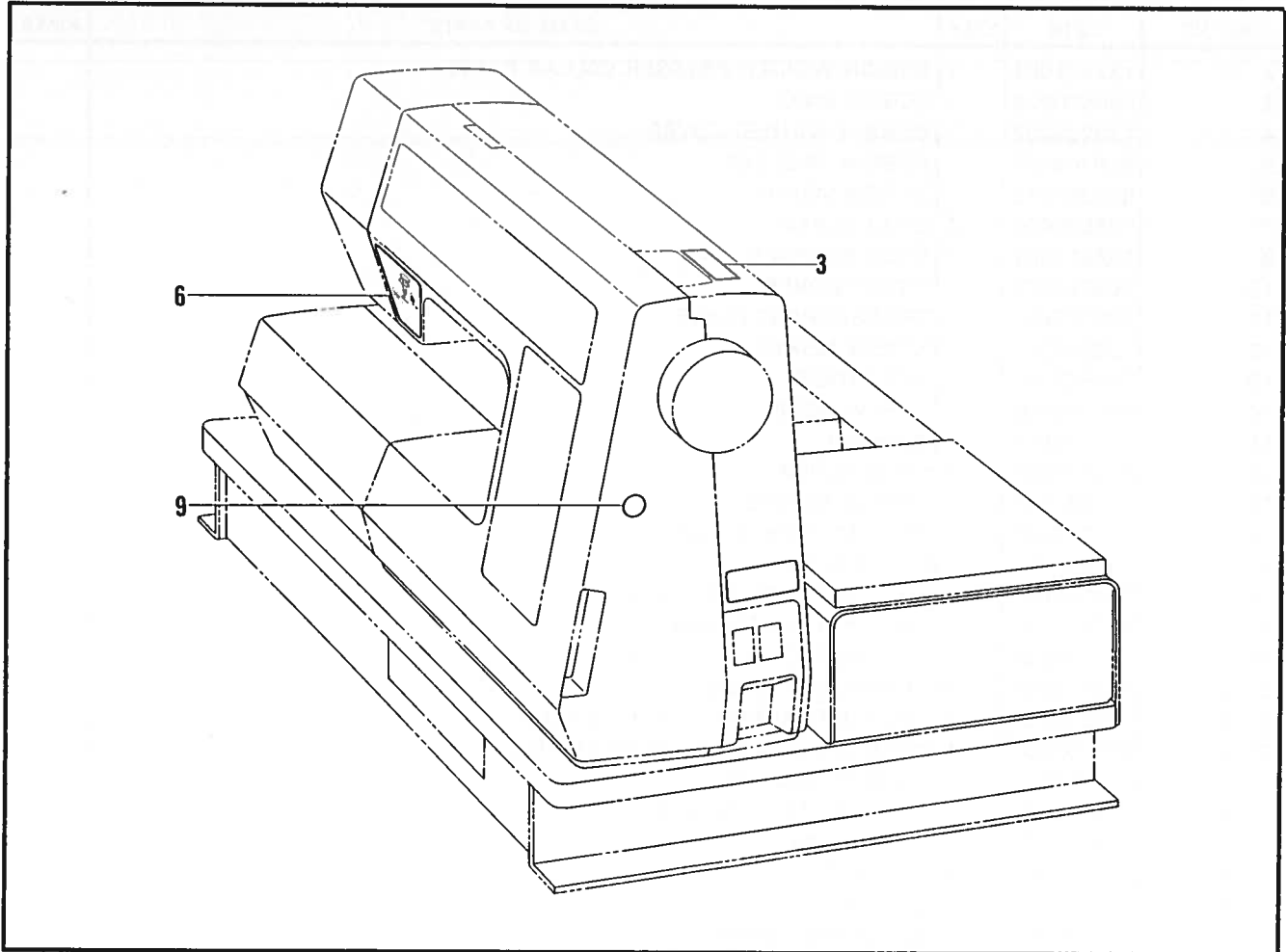

**C. Upper shaft mechanism / Obere welle / Mécanisme de l'arbre supérieur / Mecanismo de la eje superior**

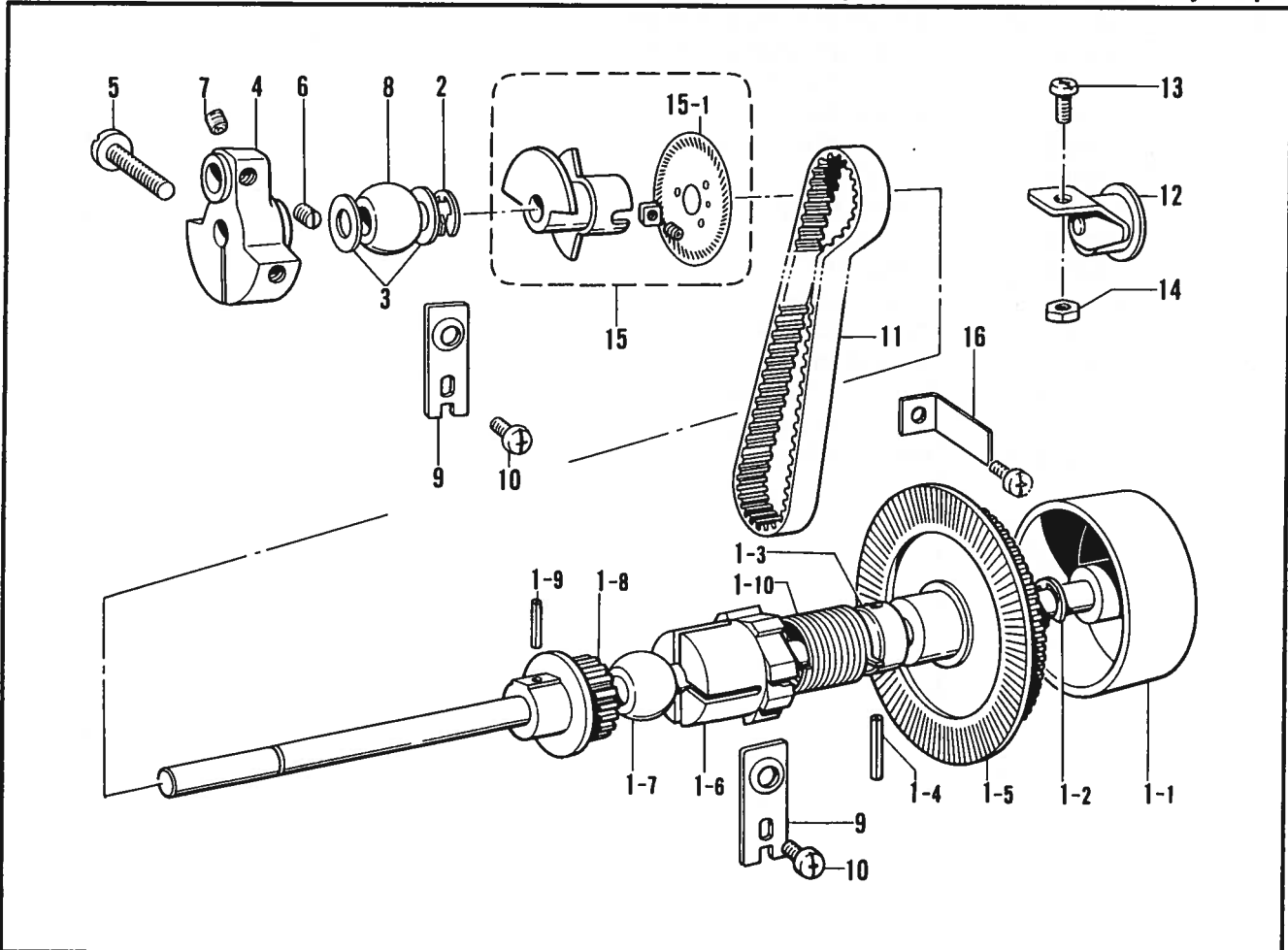



**B. Display and indicators/Anaeige und Anzeigeleuchten/  
Affichage et témoins/Rantalla de exhibición e indicadores**

REF.NO.	CODE	Q'TY	NAME OF PARTS	RMKS
3	S09855000	1	BOBBIN WINDER NEEDLE MARK	
6	S09728000	1	SEAL (3)	
9	S09831100	1	MASK TAPE (3)	

**C. Upper shaft mechanism/Obere welle/Mécanisme de l'arbre supérieur/Mecanismo de la eje superior**

REF.NO.	CODE	Q'TY	NAME OF PARTS	RMKS
1	184388001	1	UPPER SHAFT ASSEMBLY	
1-1	132266002	1	UPPER SHAFT ASSEMBLY	
1-2	048080346	1	STOP RING E8	
1-3	132269000	1	UPPER SHAFT BUSH	
1-4	047302242	1	SPRING PIN AW3	
1-5	136537001	1	T PULLEY	
1-6	132271000	1	SPRING CASE	
1-7	215616000	1	UPPER SHAFT BUSH 10X14#2	
1-8	132272000	1	TIMING PULLEY UPPER	
1-9	047251642	1	SPRING PIN AW2.5	
1-10	136894001	1	CLUTCH SPRING	
2	048080346	1	STOP RING E8	
3	131976000	2	UPPER SHAFT WASHER	
4	S09693001	1	THREAD TAKE-UP CRANK	
5	062063016	1	SCREW M6X30	
6	100251001	1	SET SCREW 6.35	
7	123006001	1	SET SCREW 6.35	
8	215616000	1	UPPER SHAFT BUSH 10X14#2	
9	132277001	2	BUSH HOLDER	
10	060401016	2	SCREW M4X10	
11	132278001	1	T BELT 170XL031	
12	132289001	1	TENSION PULLEY ASSEMBLY	
13	060401016	1	SCREW M4X10	
14	021400202	1	NUT 2-4	
15	S09695001	1	SHUTTER ASSEMBLY	
15-1	014300332	1	SCREW 3X3	
16	S09745001	1	BELT STOPPER PLATE	

D. Needle bar mechanism / Nadelstange /  
 Mécanisme de la barre à aiguille / Mecanismo de la barra de aguja

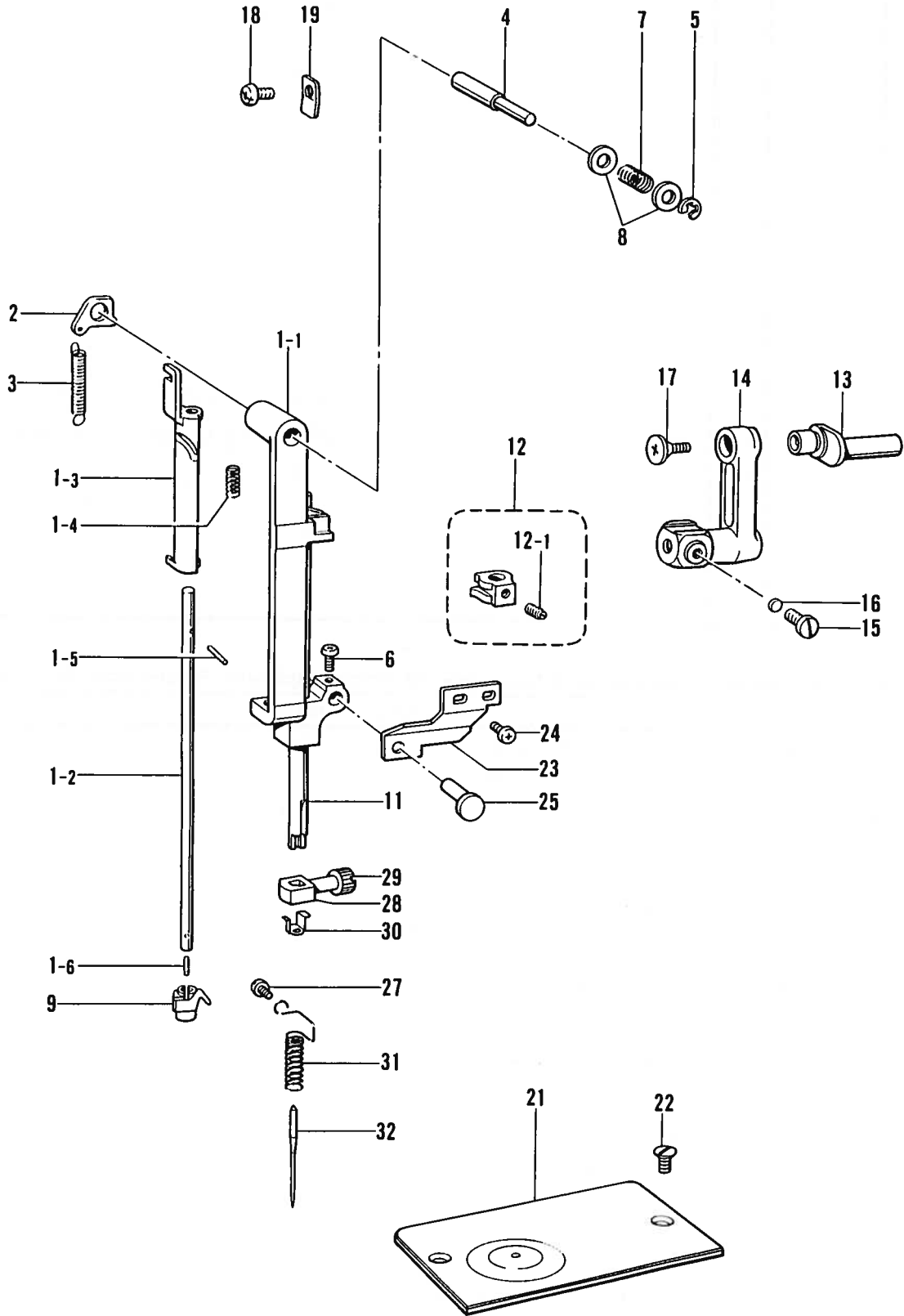

**D. Needle bar mechanism/Nadelstange/  
Mécanisme de la barre à aiguille/Mecanismo de la barra de aguja**

REF.NO.	CODE	Q'TY	NAME OF PARTS	RMKS
1	136540001	1	NEEDLE BAR BRACKET ASSEMBLY	
1-1	136541000	1	NEEDLE BAR BRACKET	
1-2	129837001	1	NEEDLE THREADER SHAFT	
1-3	129838001	1	THREAD SLIDER	
1-4	129839001	1	SPRING	
1-5	131282001	1	DOWEL PIN 2X12	
1-6	131281001	1	DOWEL PIN 2X6	
2	129847001	1	SLIDER SPRING HOOK	
3	136423001	1	SLIDER COIL SPRING	
4	136542001	1	NEEDLE BAR BRACKET SHAFT	
5	048030346	1	STOP RING E3	
6	123185001	1	SCREW 3.57X4.5	
7	136543001	1	SPRING	
8	102707003	2	WASHER	
9	129840001	1	THREADER HOOK ASSEMBLY	
11	129849001	1	NEEDLE BAR	
12	182702000	1	THREADING POSITIONING SET ASSEMBLY	
12-1	151602002	1	SET SCREW 4.37	
13	S09696001	1	NEEDLE BAR CRANK	
14	S09697001	1	NEEDLE BAR CRANK ROD ASSEMBLY	
15	009689412	1	SCREW 4.37X4.5	
16	100507000	1	WASHER	
17	132051001	1	SCREW 3.57L	
18	533777001	1	SCREW 4X8DB	
19	136544001	1	STOPPER PLATE	
21	S09699101	1	NEEDLE PLATE	
22	S09700001	2	SCREW M4	
23	S09701001	1	NEEDLE BAR PRESSER PLATE	
24	060400616	2	SCREW M4X6	
25	136536001	1	Z CONNECTING FIXING PIN	
27	100139001	1	SCREW 2.38	
28	129853001	1	NEEDLE CLAMP	
29	131226001	1	NEEDLE SET SCREW 3.57	
30	125161000	1	NEEDLE THREAD PLATE	
31	S09702001	1	SPRING	
32	100028111	1	NEEDLE	

E. Thread take-up mechanism / Fadenabnahmevorrichtung / Releveur de fil / Mecanismo del tirahilas

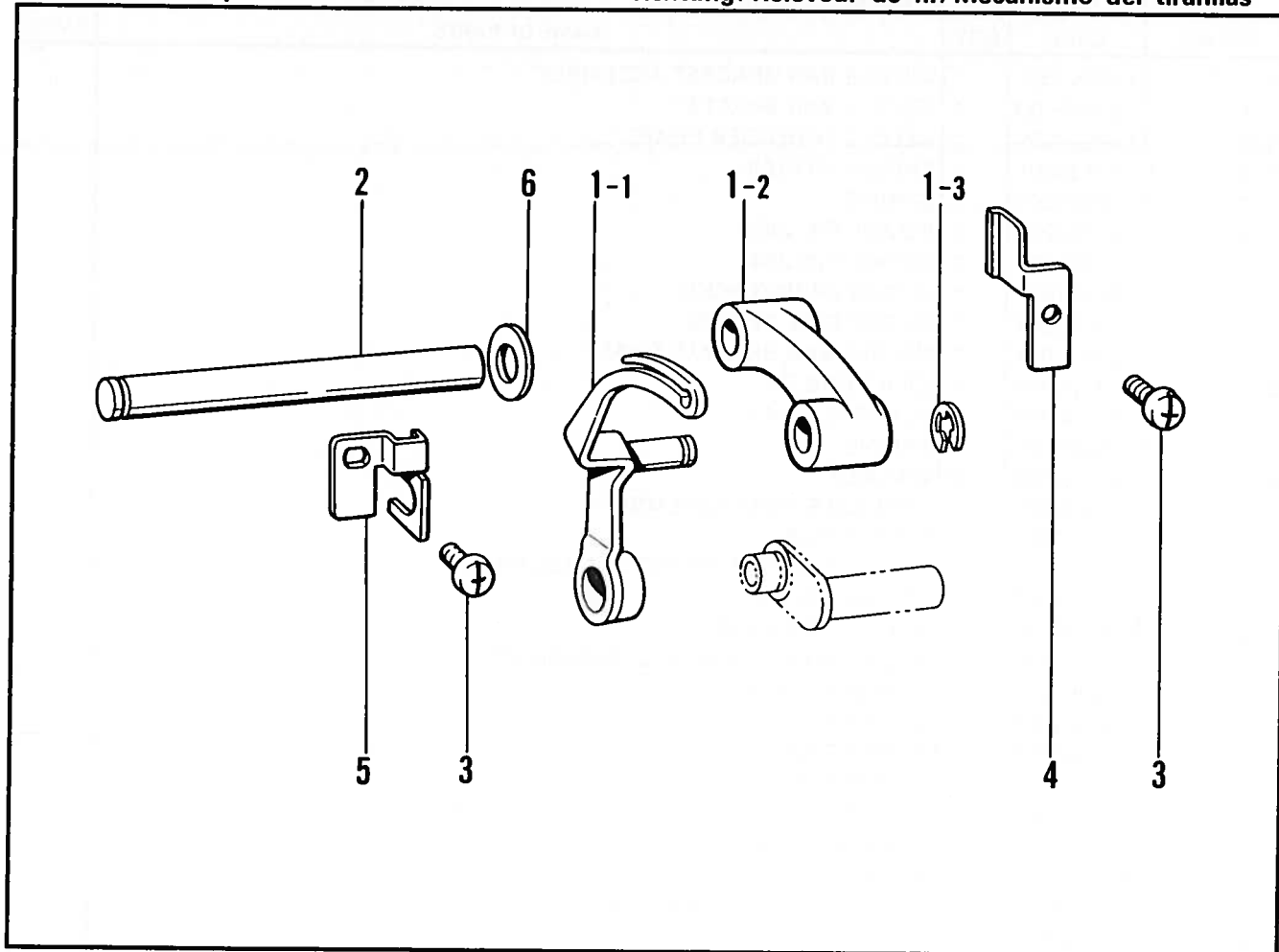

F. Presser foot mechanism (I) / Stoffdrückerfuß (I) / Mécanisme du pied presseur (I) / Mecanismo del prensateras (I)

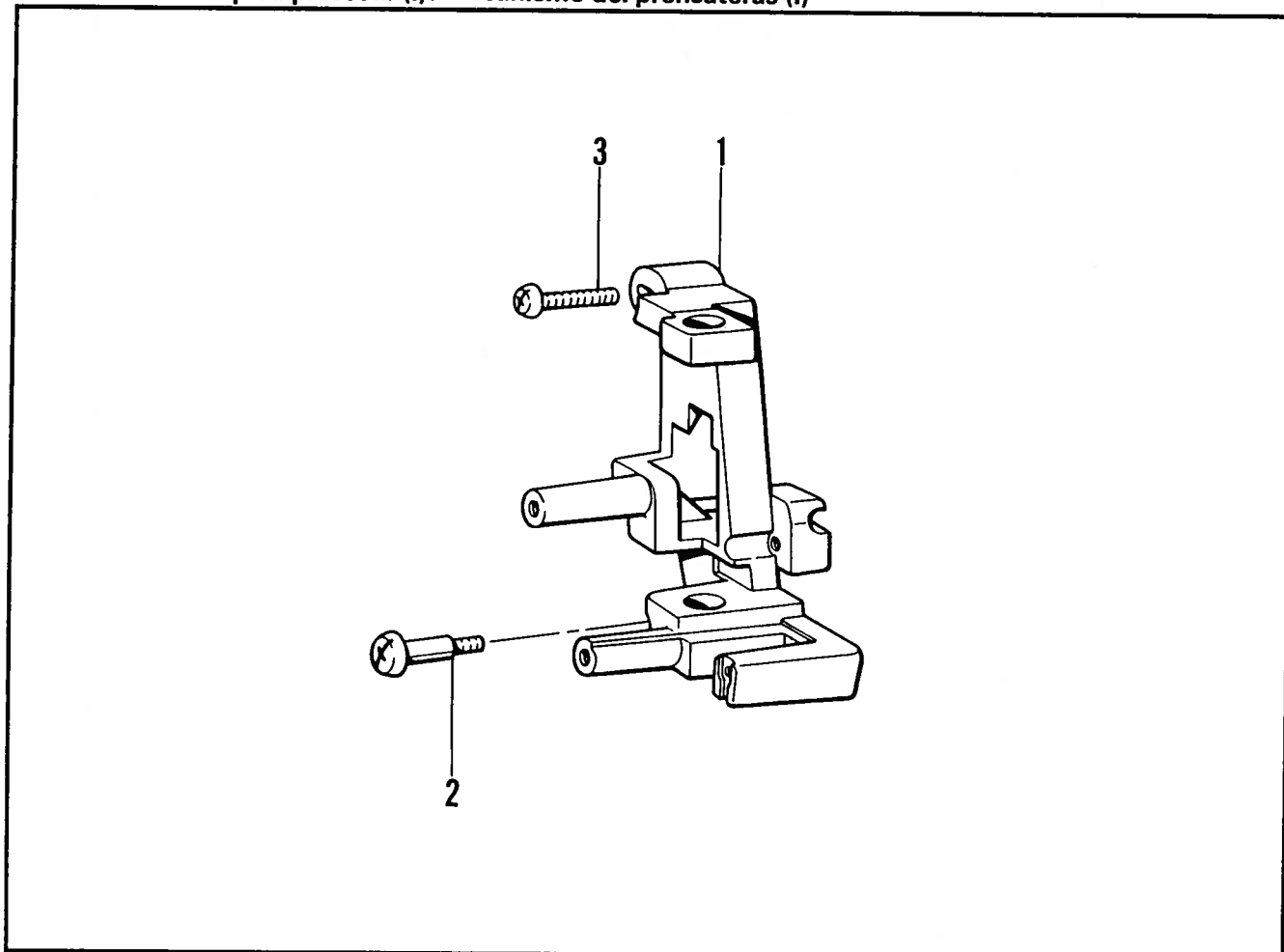

**E. Thread take-up mechanism / Fadenabnahmevorrichtung / Releveur de fil / Mecanismo del tirahilas**

REF.NO.	CODE	Q'TY	NAME OF PARTS	RMKS
1	S09703001	1	THREAD TAKE-UP ASSEMBLY	
1-1	123840001	1	THREAD TAKE-UP BRACKET	
1-2	S09704001	1	THREAD TAKE-UP SUPPORT	
1-3	048050346	1	STOP RING E5	
2	136548000	1	THREAD TAKE-UP SUPPORTER SHAFT	
3	060400616	2	SCREW M4X6	
4	136846001	1	FIXING PLATE (B)	
5	136562001	1	FIXING PLATE (A)	
6	026060235	1	WASHER 6	

**F. Presser foot mechanism (I) / Stoffdrückerfuß (I) /  
Mécanisme du pied presseur (I) / Mecanismo del prensateras (I)**

REF.NO.	CODE	Q'TY	NAME OF PARTS	RMKS
1	136557000	1	PRESSER UNIT HOLDER	
2	132470001	1	STUD SCREW M4	
3	062402016	1	SCREW M4X20	

G. Rotary hook drive assembly / Greife rantrieb /  
 Entraînement du crochet rotatif / Conjunto de mando del congrejo

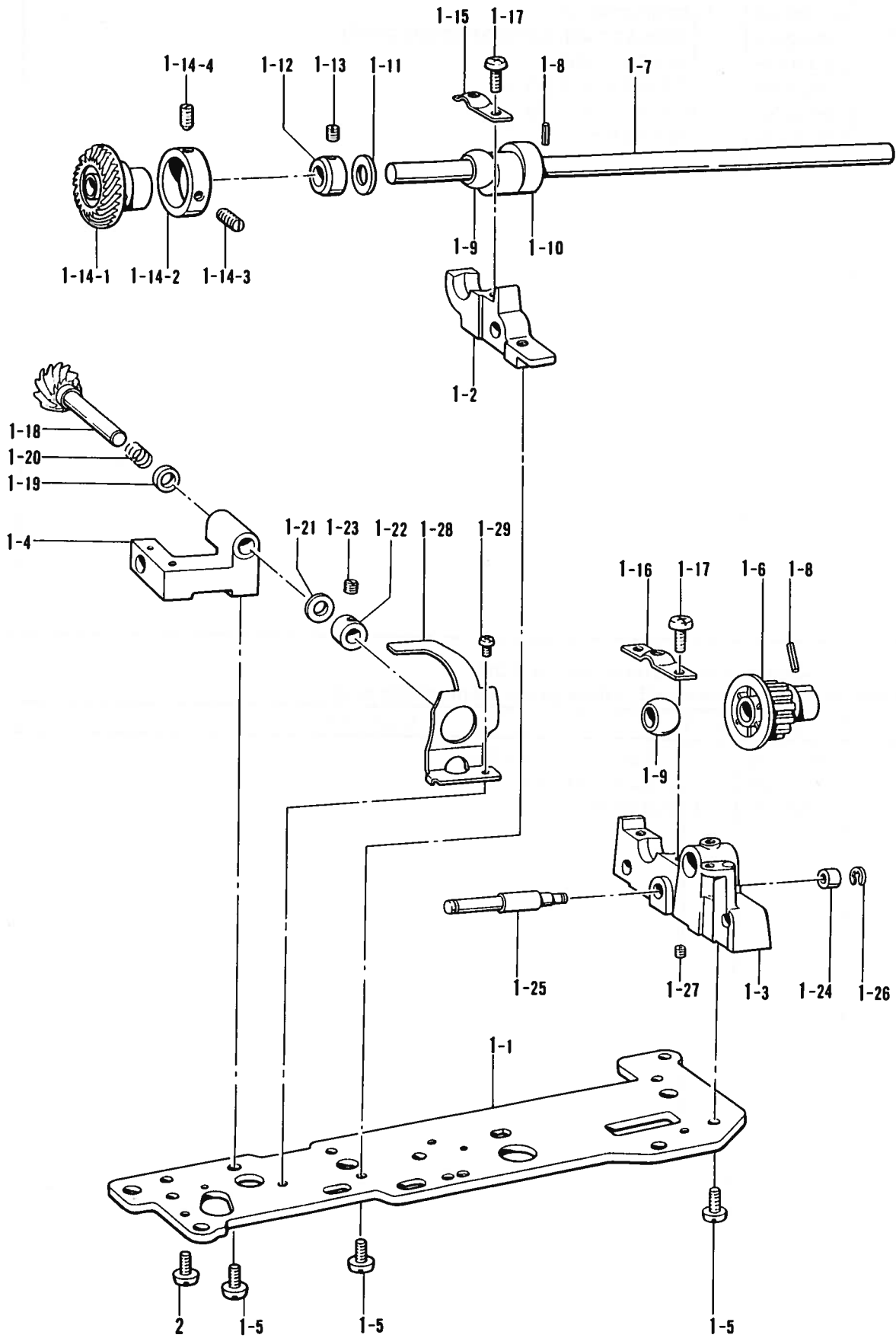

**G. Rotary hook drive assembly / Greife rantrieb /  
Entrainement du crochet rotatif / Conjunto de mando del congrejo**

REF.NO.	CODE	Q'TY	NAME OF PARTS	RMKS
1	S09725001	1	LOWER SHAFT UNIT ASSEMBLY	
1-1	136613001	1	BASE PLATE	
1-2	136629000	1	LOWER SHAFT HOLDER (LEFT)	
1-3	136636000	1	LOWER SHAFT HOLDER (RIGHT)	
1-4	132436000	1	HOOK DRIVING SHAFT HOLDER	
1-5	060401015	6	SCREW M4X10	
1-6	132422000	1	TIMING PULLEY (LOWER)	
1-7	136631000	1	LOWER SHAFT	
1-8	047251442	2	SPRING PIN AW2.5	
1-9	132420000	2	LOWER SHAFT BUSH	
1-10	136630000	1	SC CAM	
1-11	X51383000	1	WASHER	
1-12	132433001	1	SET COLLAR	
1-13	103408002	2	SCREW 4.37	
1-14-1	136633000	1	LOWER SHAFT BEVEL GEAR	
1-14-2	136634001	1	LOWER SHAFT GEAR STOPER COLLAR	
1-14-3	013681012	1	SET SCREW SM4.37	
1-14-4	135553001	1	SCREW 4.37X11	
1-15	132421001	1	LOWER SHAFT BUSH HOLDER	
1-16	136639001	1	LOWER SHAFT BUSH HOLDER (RIGHT)	
1-17	060401015	3	SCREW M4X10	
1-18	132437001	1	ROTARY HOOK SHAFT GEAR	
1-19	132994001	1	WASHER	
1-20	135622001	1	COIL SPRING	
1-21	132448000	1	WASHER	
1-22	132439001	1	SET COLLAR	
1-23	103408002	2	SCREW 4.37	
1-24	136657001	1	ROLLER	
1-25	136638001	1	FEED ROCK LEVER SHAFT	
1-26	048025346	1	STOP RING E2.5	
1-27	014400832	1	SCREW M4X8	
1-28	136660000	1	DUST GUARD	
1-29	060300416	1	SCREW M3X4	
2	060401016	4	SCREW M4X10	

H. Rotary hook mechanism/Greifervorrichtung/  
 Mécanisme du crochet rotatif/Mecanismo del cangrejo

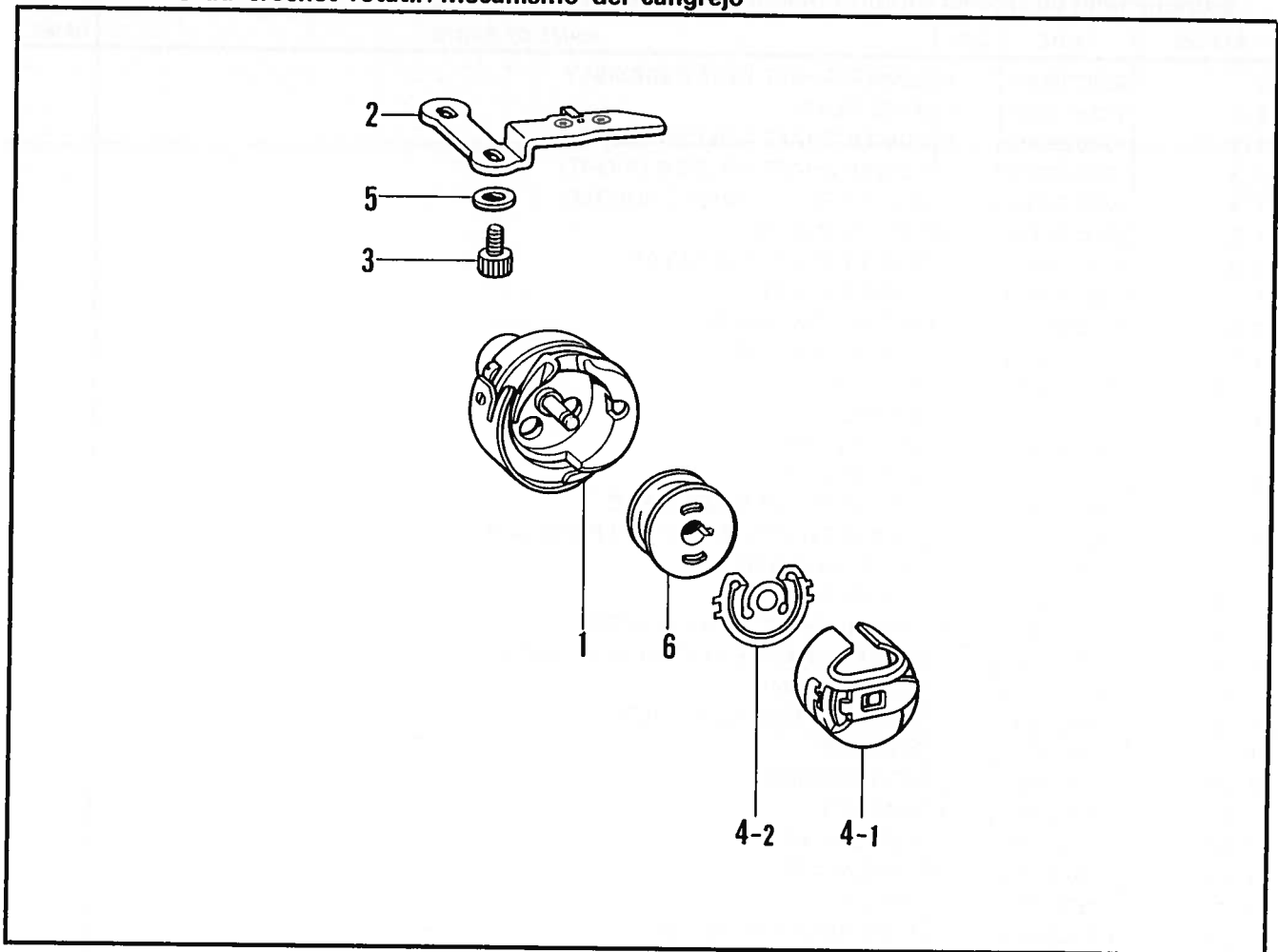

J. Bobbin winder mechanism/Spuler/  
 Mécanisme de bobineur/Mecanismo del devanador de la canilla

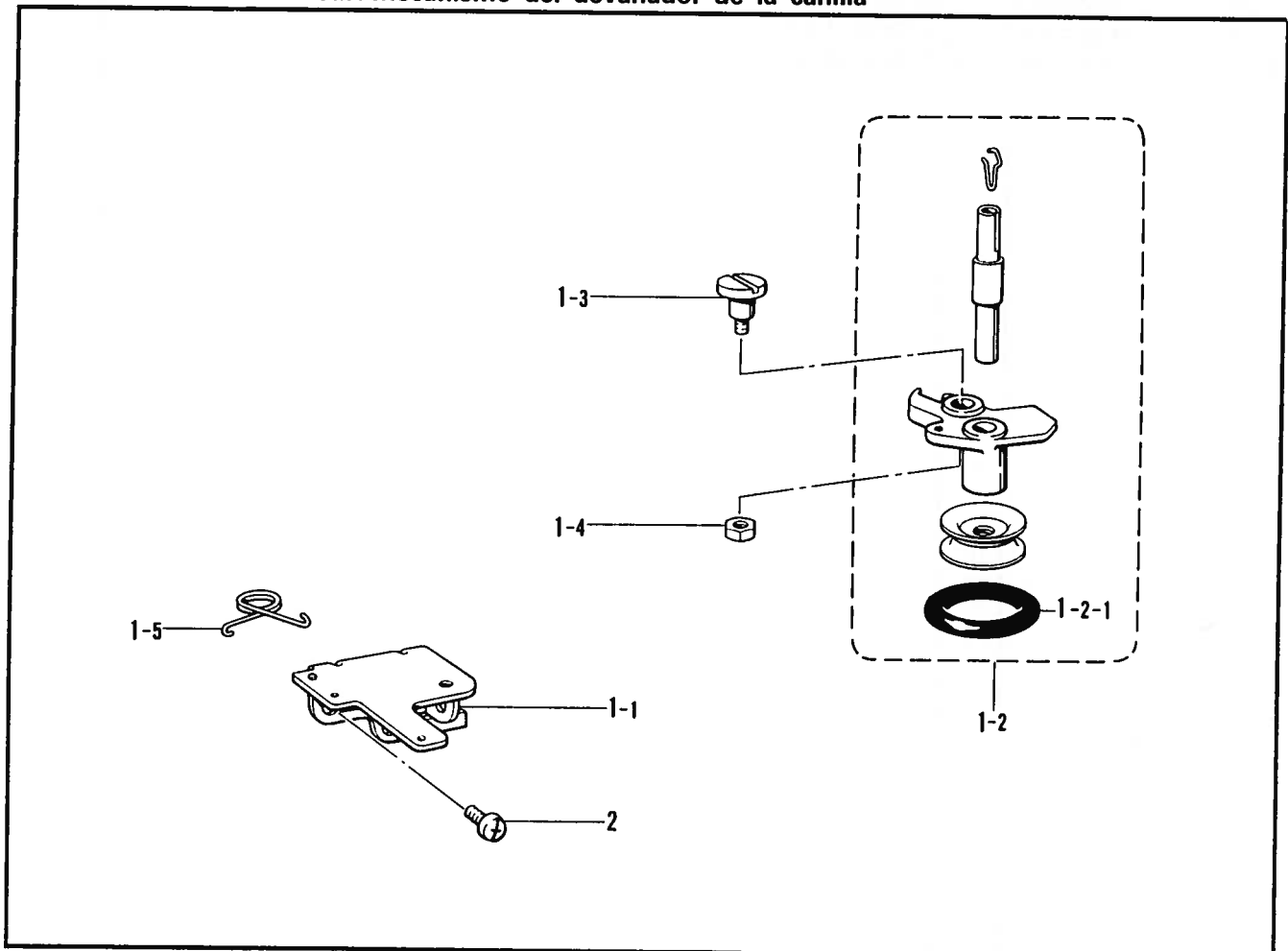



**H. Rotary hook mechanism/Greifervorrichtung/  
Mécanisme du crochet rotatif/Mecanismo del cangrejo**

REF.NO.	CODE	Q'TY	NAME OF PARTS	RMKS
1	137493001	1	ROTARY HOOK ASSEMBLY	
2	136563001	1	HOLDER POSITION ASSEMBLY	
3	018400822	2	BOLT 4X8	
4	S09706001	1	BOBBIN CASE ASSEMBLY	
4-1	S09742001	1	BOBBIN CASE ASSEMBLY	
4-2	S09748001	1	SPRING	
5	025040232	2	PLAIN WASHER 4	
6	137489001	1	BOBBIN (FOR SENSOR)	

**J. Bobbin winder mechanism/Spuler/  
Mécanisme de bobineur/Mecanismo del devanador de la canilla**

REF.NO.	CODE	Q'TY	NAME OF PARTS	RMKS
1	S09707001	1	BOBBIN WINDER ASSEMBLY	
1-1	132312001	1	BOBBIN WINDER BASE PLATE	
1-2	132313001	1	BOBBIN WINDER	
1-2-1	120448001	1	RUBBER RING	
1-3	120263001	1	STUD SCREW 4.37	
1-4	102571003	1	NUT 4.37	
1-5	136560001	1	TWIST SPRING	
2	060400616	1	SCREW M4X6	

**K. Threading mechanism / FadenführungsVorrichtung /  
Mécanisme de l'enfilage / Mecanismo de la enhebrado**

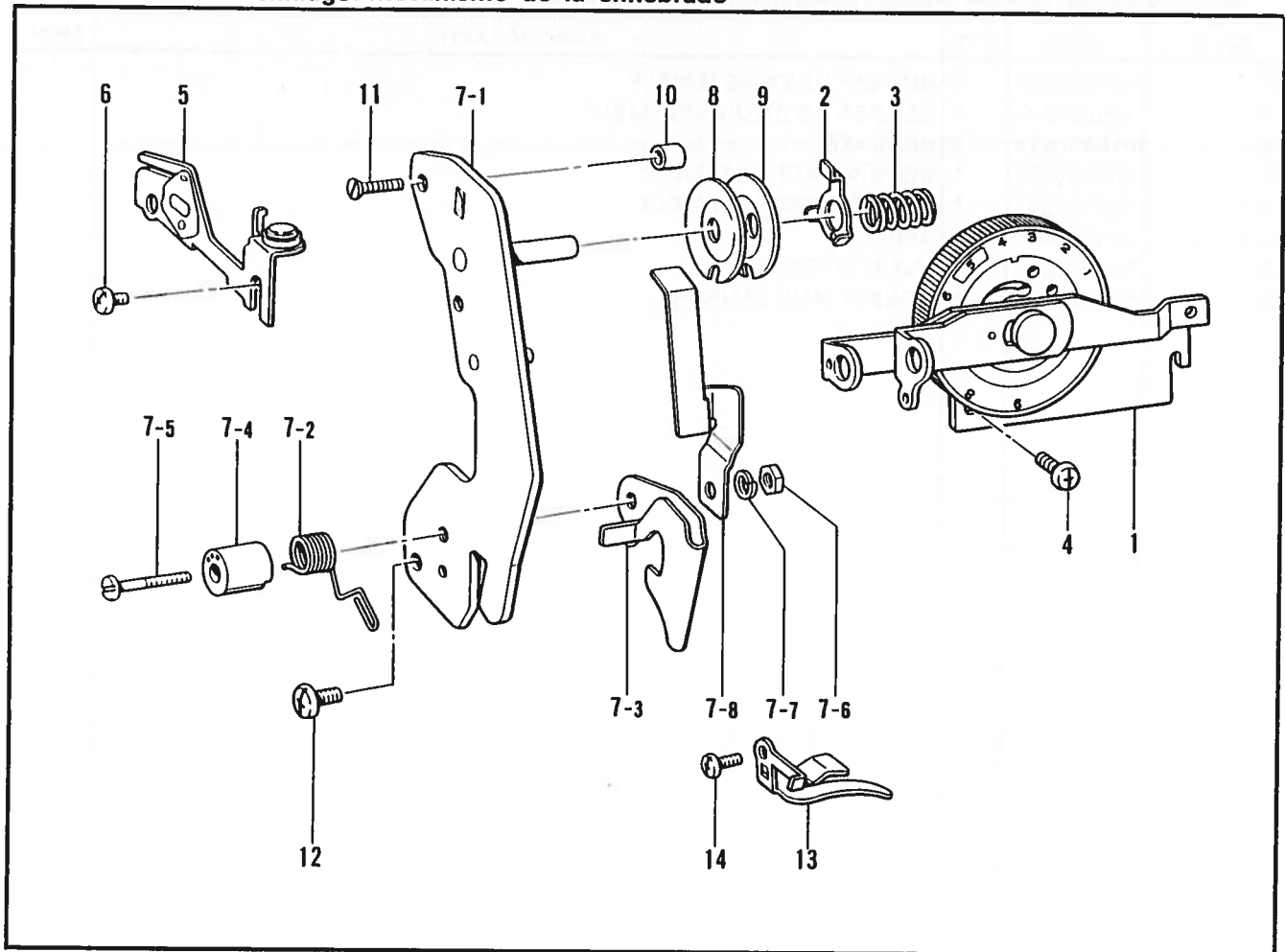

**L. Presser foot mechanism (II) / Stoffdrückerfuß (II) /  
Mécanisme du pied presseur (II) / Mecanismo del prensateras (II)**

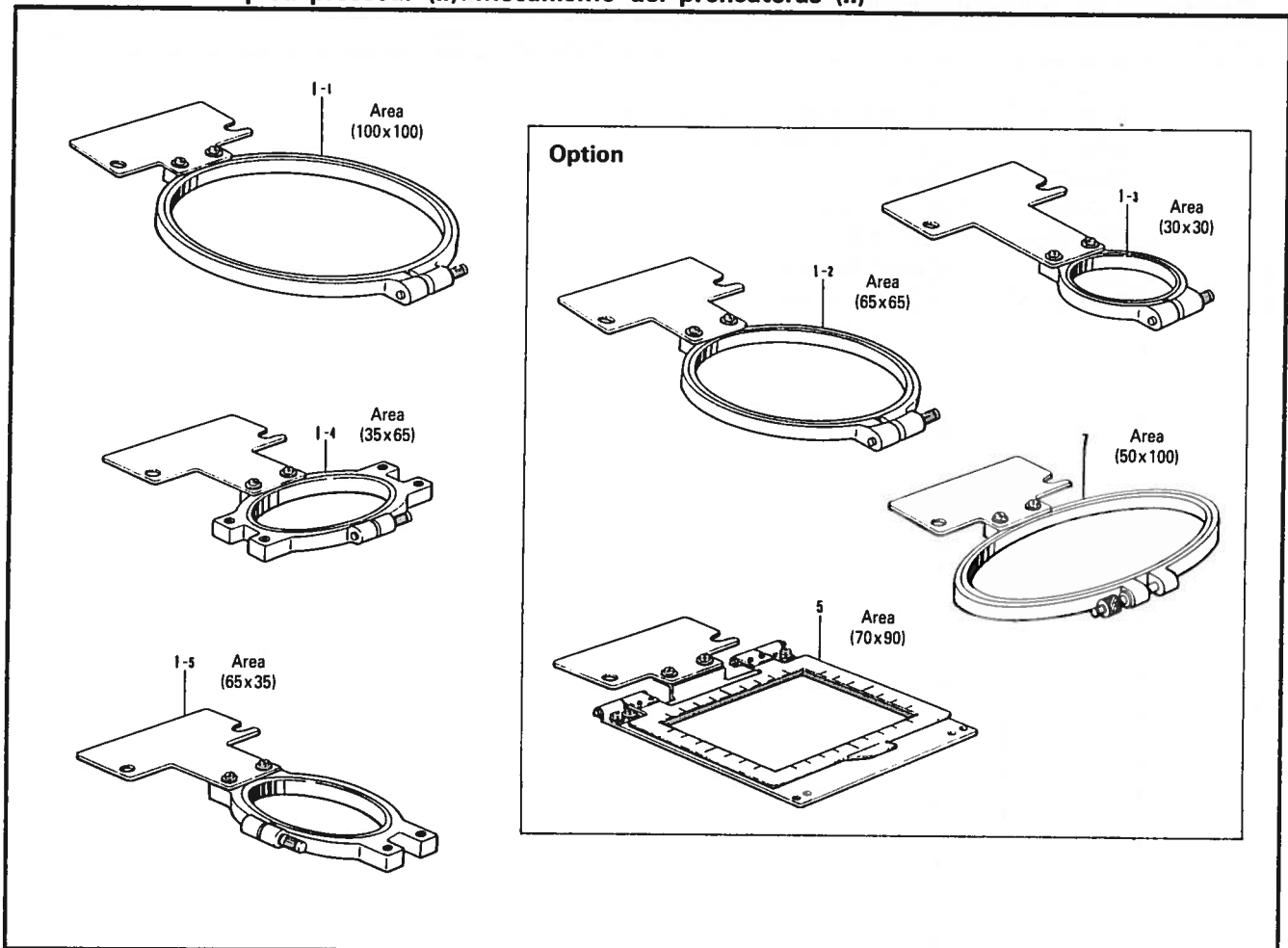

**K. Threading mechanism/FadenführungsVorrichtung/  
Mécanisme de l'enfilage/Mecanismo de la enhebrado**

REF.NO.	CODE	Q'TY	NAME OF PARTS	RMKS
1	S09708001	1	THREAD TENSION BRACKET ASSEMBLY	
2	130006001	1	THREAD TENSION SPRING SEAT	
3	S09712001	1	THREAD TENSION SPRING	
4	060300616	2	SCREW M3X6	
5	136572001	1	THREAD GUIDE ASSEMBLY	
6	060300616	1	SCREW M3X6	
7	S09715001	1	THREAD HANDLING AREA ASSEMBLY	
7-1	S09716001	1	THREAD HANDLING AREA BASE ASSEMBLY	
7-2	S09719001	1	THREAD TAKE-UP SPRING	
7-3	136578001	1	THREAD TAKE-UP SPRING COVER	
7-4	132305000	1	THREAD TAKE-UP SPRING CASE	
7-5	060352002	1	SCREW 35X20	
7-6	021670403	1	NUT 3.57	
7-7	028350242	1	SPRING WASHER 2-3.5	
7-8	138011001	1	SHUTTER	
8	124241001	1	TENSION DISC	
9	129376001	1	TENSION DISC	
10	124059001	1	COLLAR	
11	132387001	1	SCREW M3	
12	060400616	1	SCREW M4X6	
13	136579001	1	THREAD GUIDE	
14	060300616	1	SCREW M3X6	

**L. Presser foot mechanism (II)/Stoffdrückerfuß (II)/  
Mécanisme du pied presseur (II)/Mecanismo del prensateras (II)**

REF.NO.	CODE	Q'TY	ヒンメイ	NAME OF PARTS	RMKS
1-1	S09843201	1	フクAクミ	HOOP (A) ASSEMBLY (100X100)	
1-4	S09846201	1	フクDクミ	HOOP (D) ASSEMBLY (35X65)	
1-5	S09847201	1	フクEクミ	HOOP (E) ASSEMBLY (65X35)	
<OPTION>					
1-2	S09844201	1	フクBクミ	HOOP (B) ASSEMBLY (65X65)	
1-3	S09845201	1	フクCクミ	HOOP (C) ASSEMBLY (30X30)	
5	S09848001	1	マグ"ネットクランプ"	MAGNET CLAMP (70X90)	
7	157340101	1	ダ"エンフク3X6クミ	HOOP 3X6 ASSEMBLY (50X100)	

M. Motor mechanism/Motor/Mécanisme du moteur/Mecanismo del caja de controles

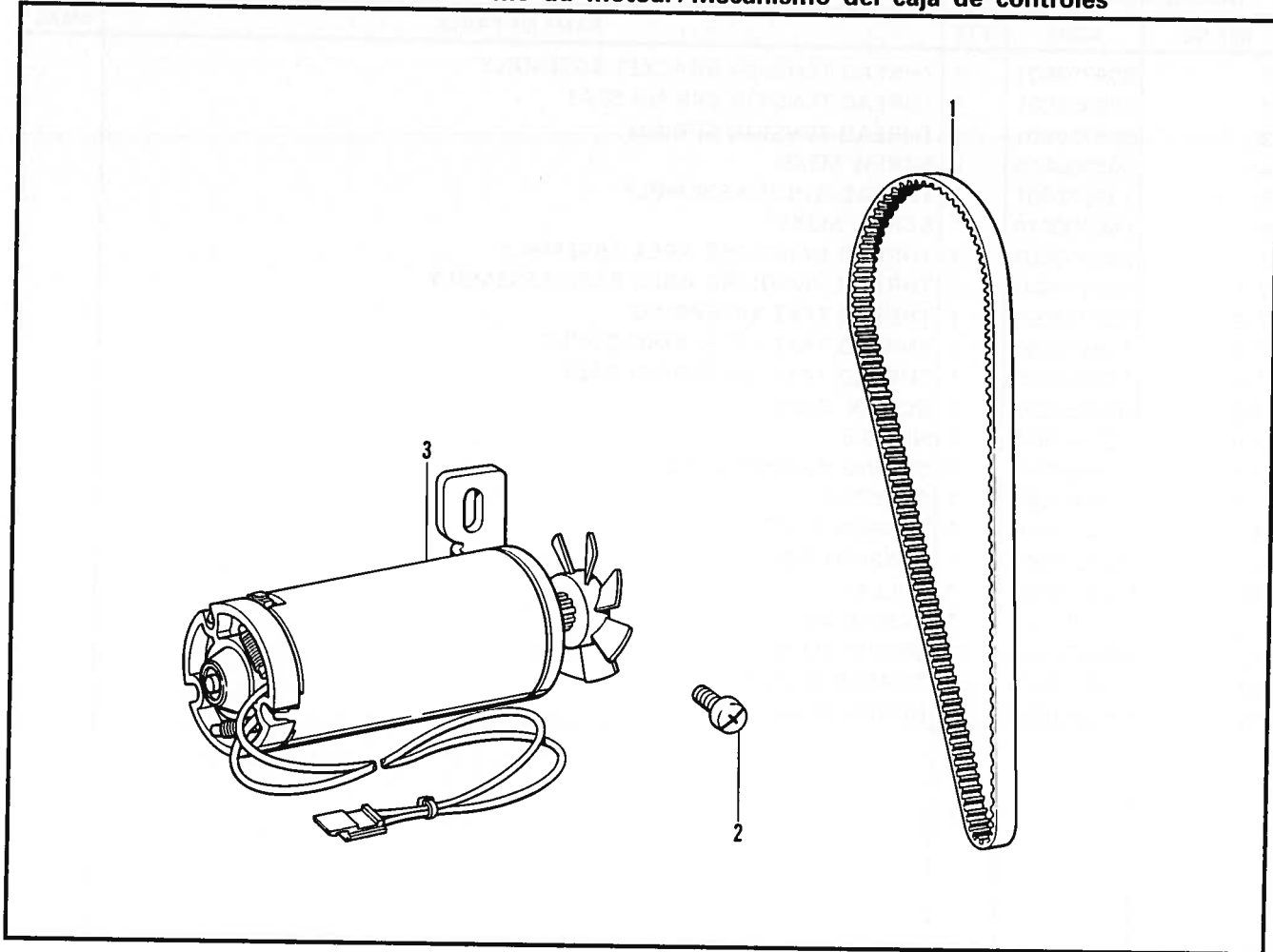

N. Thread breakage detector mechanism/Fadenbruchfühler/  
Mécanisme du détecteur de cassure du fil/Mecanismo del sensor de cortes en el hilo

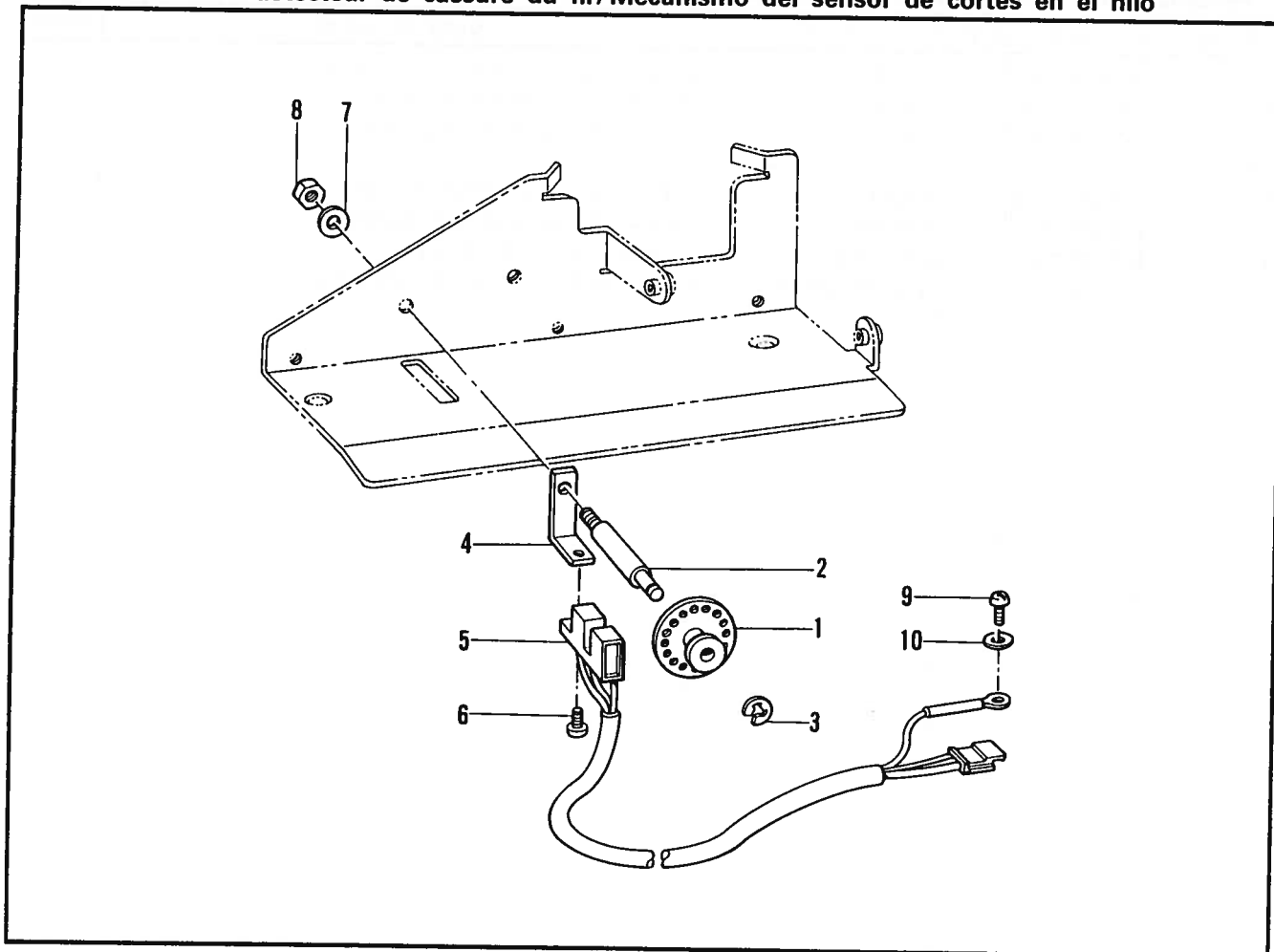

**M. Motor mechanism/Motor/Mécanisme du moteur/Mecanismo del caja de controles**

REF.NO.	CODE	Q'TY	NAME OF PARTS	RMKS
1	136582001	1	TIMING BELT 190XXLO25	
2	537235001	2	SCREW 5X12DB	
3	233297001	1	MN-201-82 MOTOR	

**N. Thread breakage detector mechanism/Fadenbruchfühler/  
Mécanisme du détecteur de cassure du fil/Mecanismo del sensor de cortes en el hilo**

REF.NO.	CODE	Q'TY	NAME OF PARTS	RMKS
1	157255000	1	PULLEY (A)	
2	157262001	1	PULLEY SHAFT	
3	048020346	1	STOP RING E2	
4	157263001	1	SENSOR SETTING PLATE	
5	157256001	1	THREAD BREAKAGE DETECTING CIRCUIT ASS	
6	062300505	1	SCREW 3X5	
7	025030233	1	PLAIN WASHER 3	
8	021300103	1	NUT 1-3	
9	062300405	1	SCREW 3X4	
10	025030133	1	PLAIN WASHER 3	



**P. Power supply equipment (I)/Stromversorgung (I)/  
Mécanisme de léquipement en alimentation électrique (I)/  
Mecanismo de la equipo de alimentación de corriente (I)**

REF.NO.	CODE	Q'TY	NAME OF PARTS	RMKS
1	S09910001	1	7 SEG CIRCUIT BOARD ASSEMBLY	
2	S09912101	1	LAMP CIRCUIT BOARD ASSEMBLY	
3	S09914001	1	PELAY CIRCUIT BOARD ASSEMBLY	
4	S09916001	1	LCD-MODULE ASSEMBLY	
5	S09992100	1	SWITCH PANEL	
6	S09901001	1	PLUG CASE WOJ ASSEMBLY	
7	S09906001	1	NP CIRCUIT BOARD ASSEMBLY	
8	S09908101	1	SENSOR COVER ASSEMBLY	
9	S09919001	1	SOLENOID ASSEMBLY	
10	S09966001	2	EARTH CORD (A) ASSEMBLY	
11	S09783000	4	COLLAR (2)	
12	062300806	4	SCREW 3X8	
13	028030243	4	SPRING WASHER 2-3	
14	025030133	4	PLAIN WASHER 3	
15	136893001	1	CIRCUIT BOARD PRESSER (B)	
16	U06923001	2	SCREW 3X10	
17	S09784000	2	COLLAR (1)	
18	S09783000	2	COLLAR (2)	
19	062301205	2	SCREW 3X12	
20	062300806	2	SCREW 3X8	
21	028030243	4	SPRING WASHER 2-3	
22	025030133	4	PLAIN WASHER 3	
23	S09752001	1	CIRCUIT BOARD FIXING PLATE	
24	S09832101	1	CIRCUIT BOARD BRACKET	
25	062300405	4	SCREW 3X4	
26	025030133	4	PLAIN WASHER 3	
27	525664000	3	CORD HOLDER #6	
28	062300505	2	SCREW 3X5	
29	025030133	3	PLAIN WASHER 3	
30	S00470000	1	CORD HOLDER #16	
31	U06923001	1	SCREW 3X10	
32	025030133	1	PLAIN WASHER 3	
33	S09850001	1	LCD BRACKET	
34	S09820000	2	COLLAR (3)	
35	060400816	1	SCREW M4X8	
36	S09713101	1	SOLENOID SPRING	
37	S09714001	1	PIN	
38	048020346	2	STOP RING E2	
39	060300616	3	SCREW M3X6	
40	026030234	3	PLAIN WASHER 3	
41	S09720001	1	SOLENOID SETTING PLATE	
42	060300616	1	SCREW M3X6	
43	062300405	2	SCREW 3X4	
44	U06923001	4	SCREW 3X10	
45	136851001	4	CIRCUIT BOARD PRESSER	
46	061300416	2	SCREW M3X4	
47	060300616	2	SCREW M3X6	
48	136851001	1	CIRCUIT BOARD PRESSER	
49	025040232	1	PLAIN WASHER 4	
50	062300505	1	SCREW 3X5	
<b>&lt;FOR SUPPLY&gt;</b>				
51	137286001	1	SENSOR COVER	

Q. Feed guide mechanism (1)/Transportführung (1)/  
 Mécanisme du guide de l'entraînement (1)/Mecanismo de la guía de alimentación (1)

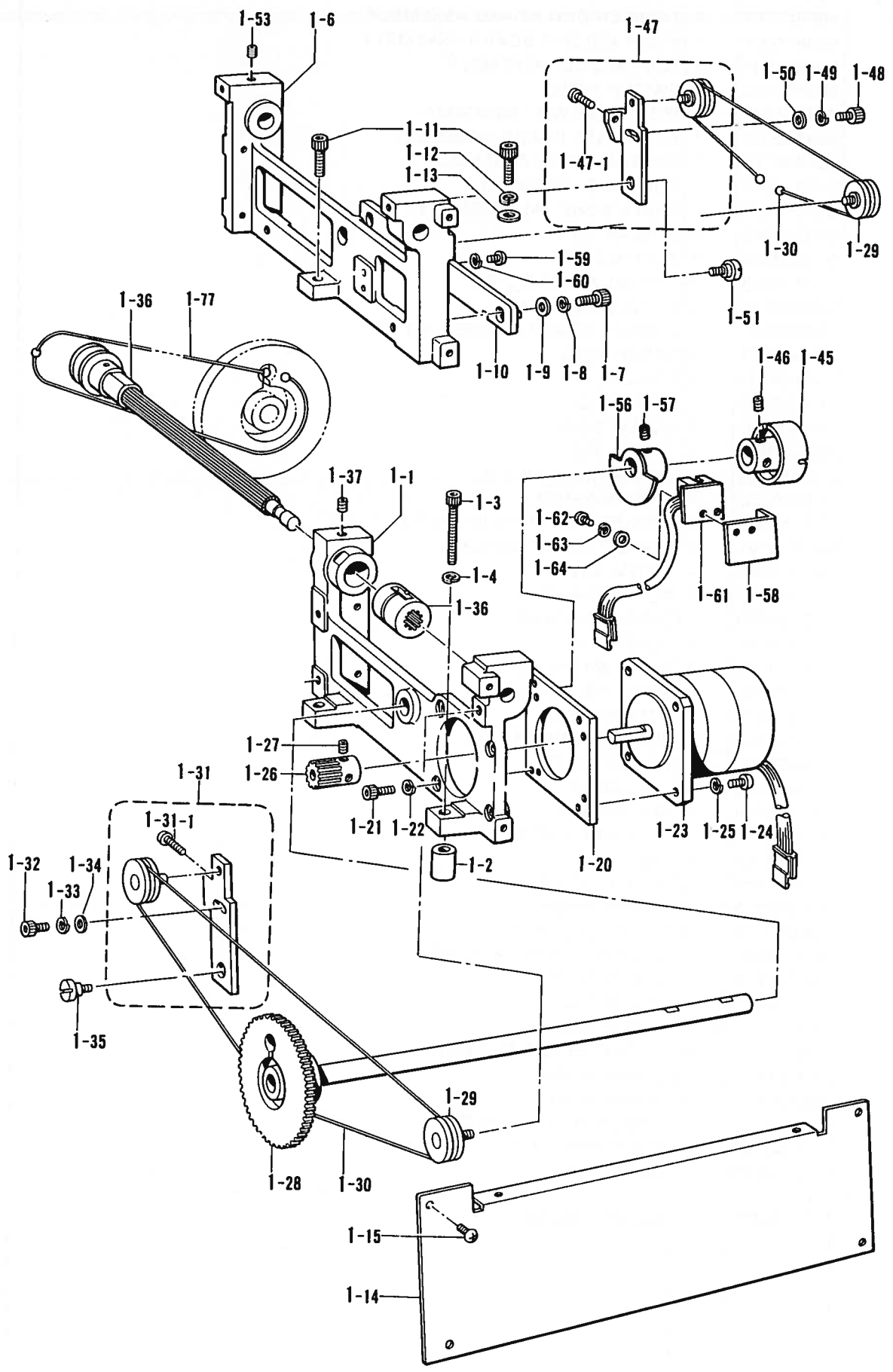



Q. Feed guide mechanism (1)/Transportführung (1)/  
 Mécanisme du guide de l'entraînement (1)/Mecanismo de la guía de alimentación (1)

REF.NO.	CODE	Q'TY	NAME OF PARTS	RMKS
1	S09849001	1	XY FEED UNIT ASSEMBLY	
1-1	S09812101	1	FRAME (RIGHT)	
1-2	S09840001	2	SPACER	
1-3	018503022	2	BOLT 5X30	
1-4	028050242	2	SPRING WASHER 2-5	
1-6	S09811101	1	FRAME (LEFT)	
1-7	018061222	2	BOLT 6X12	
1-8	028060242	2	SPRING WASHER 2-6	
1-9	025060232	2	PLAIN WASHER 6	
1-10	S09842101	1	BRACKET	
1-11	018061622	3	BOLT 6X16	
1-12	028060242	2	SPRING WASHER 2-6	
1-13	025060232	2	PLAIN WASHER 6	
1-14	S09802001	1	CONNECTING PLATE	
1-15	060400816	4	SCREW M4X8	
1-20	S09790001	1	MOTOR BRACKET (Y)	
1-21	018401222	4	BOLT 4X12	
1-22	028040245	4	SPRING WASHER 2-4	
1-23	Z22720001	1	BH200575022-BYY	
1-24	062401016	4	SCREW 4X10	
1-25	028040245	4	SPRING WASHER 2-4	
1-26	S09755001	1	GEAR	
1-27	013680512	2	SET SCREW 4.37	
1-28	S09759001	1	PULLEY SHAFT ASSEMBLY	
1-29	S09835000	2	BEARING (B)	
1-30	S09836000	2	Y MINI ROPE	
1-31	S09765001	1	TENSION PULLEY (LEFT) ASSEMBLY	
1-31-1	062301606	1	SCREW 3X16	
1-32	018401022	1	BOLT 4X10	
1-33	028040245	1	SPRING WASHER 2-4	
1-34	025040232	1	PLAIN WASHER 4	
1-35	S09774001	1	STUD SCREW M5	
1-36	S09761001	1	SPLINE SHAFT ASSEMBLY	
1-37	014400822	1	SET SCREW 4	
1-45	S09778001	1	PULLEY (Y)	
1-46	013680512	2	SET SCREW 4.37	
1-47	S09768001	1	TENSION PULLEY (RIGHT) ASSEMBLY	
1-47-1	062301606	1	SCREW 3X16	
1-48	018401022	1	BOLT 4X10	
1-49	028040245	1	SPRING WASHER 2-4	
1-50	025040232	1	PLAIN WASHER 4	
1-51	S09774001	1	STUD SCREW M5	
1-53	014400822	1	SET SCREW 4	
1-56	S09770001	1	Y-POSITION DOG	
1-57	013680512	2	SET SCREW 4.37	
1-58	S09781001	1	SENSOR BRACKET (Y)	
1-59	062301606	2	SCREW 3X16	
1-60	028030245	2	SPRING WASHER 2-3	
1-61	S09936001	1	Y INDEX SUBSTRATE ASSEMBLY	
1-62	062300505	2	SCREW 3X5	
1-63	028030245	2	SPRING WASHER 2-3	
1-64	025030135	2	PLAIN WASHER 3	
1-77	S09771000	1	X-DRIVE ROPE	

Q. Feed guide mechanism (2)/Transportführung (2)/  
 Mécanisme du guide de l'entraînement (2)/Mecanismo de la guía de alimentación (2)

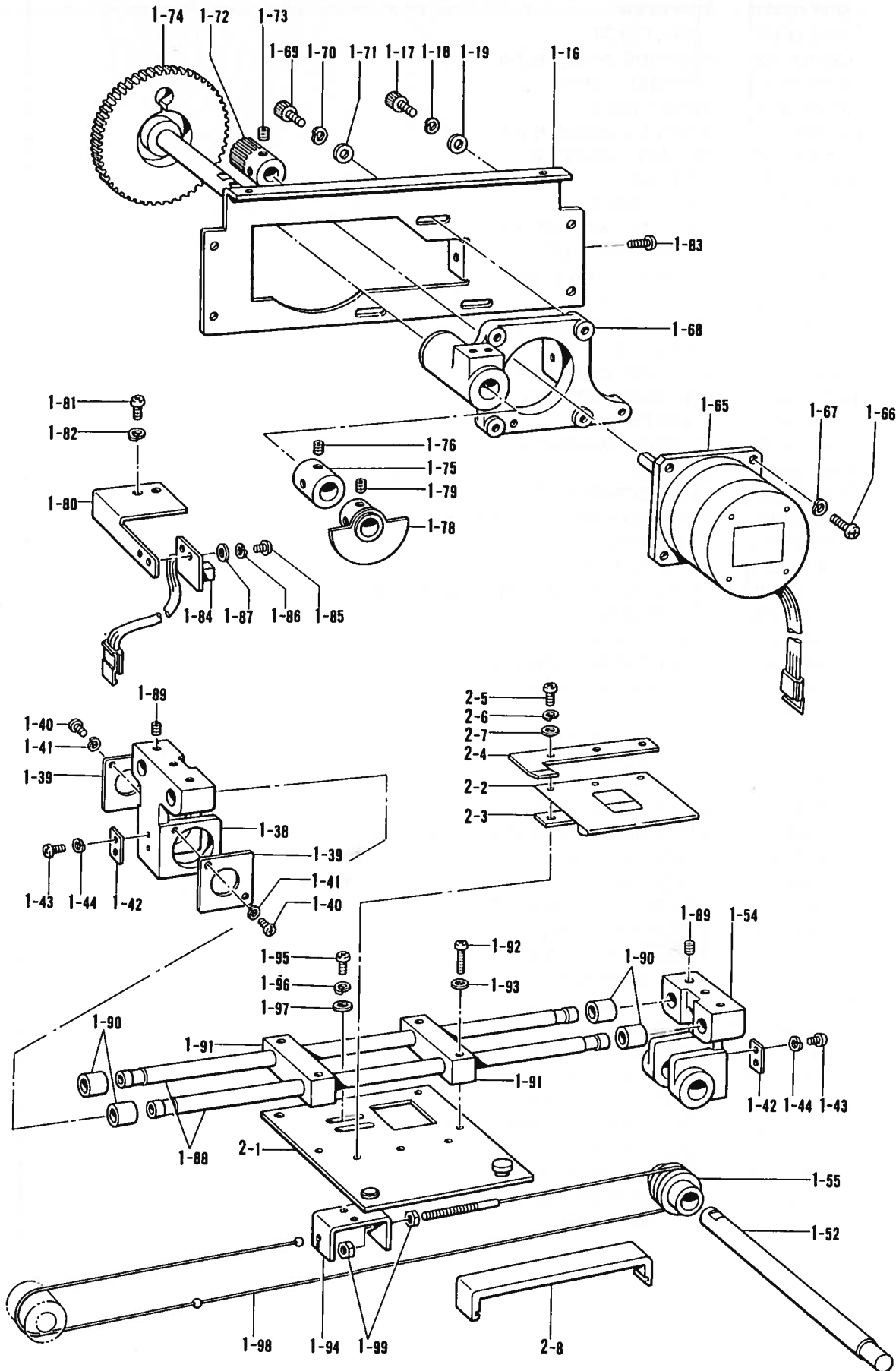

**Q. Feed guide mechanism (2)/Transportführung (2)/  
Mécanisme du guide de l'entraînement (2)/Mecanismo de la guía de alimentación (2)**

REF.NO.	CODE	Q'TY	NAME OF PARTS	RMKS
1-16	S09791001	1	BASE PLATE	
1-17	018401222	4	BOLT 4X12	
1-18	028040245	4	SPRING WASHER 2-4	
1-19	025040232	4	PLAIN WASHER 4	
1-38	S09795001	1	METAL HOLDER (LEFT)	
1-39	S09772001	2	NUT PRESSER	
1-40	062300505	4	SCREW 3X5	
1-41	028030245	4	SPRING WASHER 2-3	
1-42	S09773001	2	WIRE PRESSER	
1-43	062300612	4	SCREW 3X6	
1-44	028030242	4	SPRING WASHER 2-3	
1-52	S09776001	1	GUIDE SHAFT	
1-54	S09796001	1	METAL HOLDER (RIGHT)	
1-55	S09775000	1	IDLE PULLEY	
1-65	Z22710001	1	BH200575021-BXX	
1-66	062401016	4	SCREW 4X10	
1-67	028040245	4	SPRING WASHER 2-4	
1-68	S09807001	1	MOTOR BRACKET (X)	
1-69	018401022	3	BOLT 4X10	
1-70	028040245	3	SPRING WASHER 2-4	
1-71	025040232	3	PLAIN WASHER 4	
1-72	S09755001	1	GEAR	
1-73	013680512	2	SET SCREW 4.37	
1-74	S09756001	1	GEAR SHAFT ASSEMBLY	
1-75	S09788001	1	COLLAR (X)	
1-76	013680512	2	SET SCREW 4.37	
1-78	S09770001	1	Y-POSITION DOG	
1-79	013680512	2	SET SCREW 4.37	
1-80	S09785001	1	SENSOR BRACKET (X)	
1-81	062300502	2	SCREW 3X5	
1-82	028030242	2	SPRING WASHER 2-3	
1-83	062402005	1	SCREW 4X20	
1-84	S09933001	1	X INDEX SUBSTRATE ASSEMBLY	
1-85	062300505	2	SCREW 3X5	
1-86	028030245	2	SPRING WASHER 2-3	
1-87	025030135	2	PLAIN WASHER 3	
1-88	S09797101	2	SLIDE SHAFT	
1-89	014400822	4	SET SCREW 4	
1-90	S09777000	4	STOPPER COLLAR	
1-91	S09782100	2	SLIDER	
1-92	062672012	4	SCREW 357X20	
1-93	025350233	4	WASHER 3.5	
1-94	S09780001	1	WIRE HOOK	
1-95	062300805	2	SCREW 3X8	
1-96	028030245	2	SPRING WASHER 2-3	
1-97	025030233	2	PLAIN WASHER 3	
1-98	S09779000	1	X MINI ROPE	
1-99	021400102	2	NUT 4	
2-1	S09823101	1	SLIDE PLATE ASSEMBLY	
2-2	S09830100	1	PLATE SPRING (A)	
2-3	S09827001	1	PRESS SPACER	
2-4	S09828101	1	PRESSER PLATE	
2-5	062671014	3	SCREW 357X10	
2-6	028350243	3	WASHER 2-3.5	
2-7	025350233	3	WASHER 3.5	
2-8	S09837100	1	SLIDER COVER	

R. Upper threading mechanism/Oberer fadens/  
 Mécanisme de l'enfilage supérieur/Mecanismo de le enhebrado superior

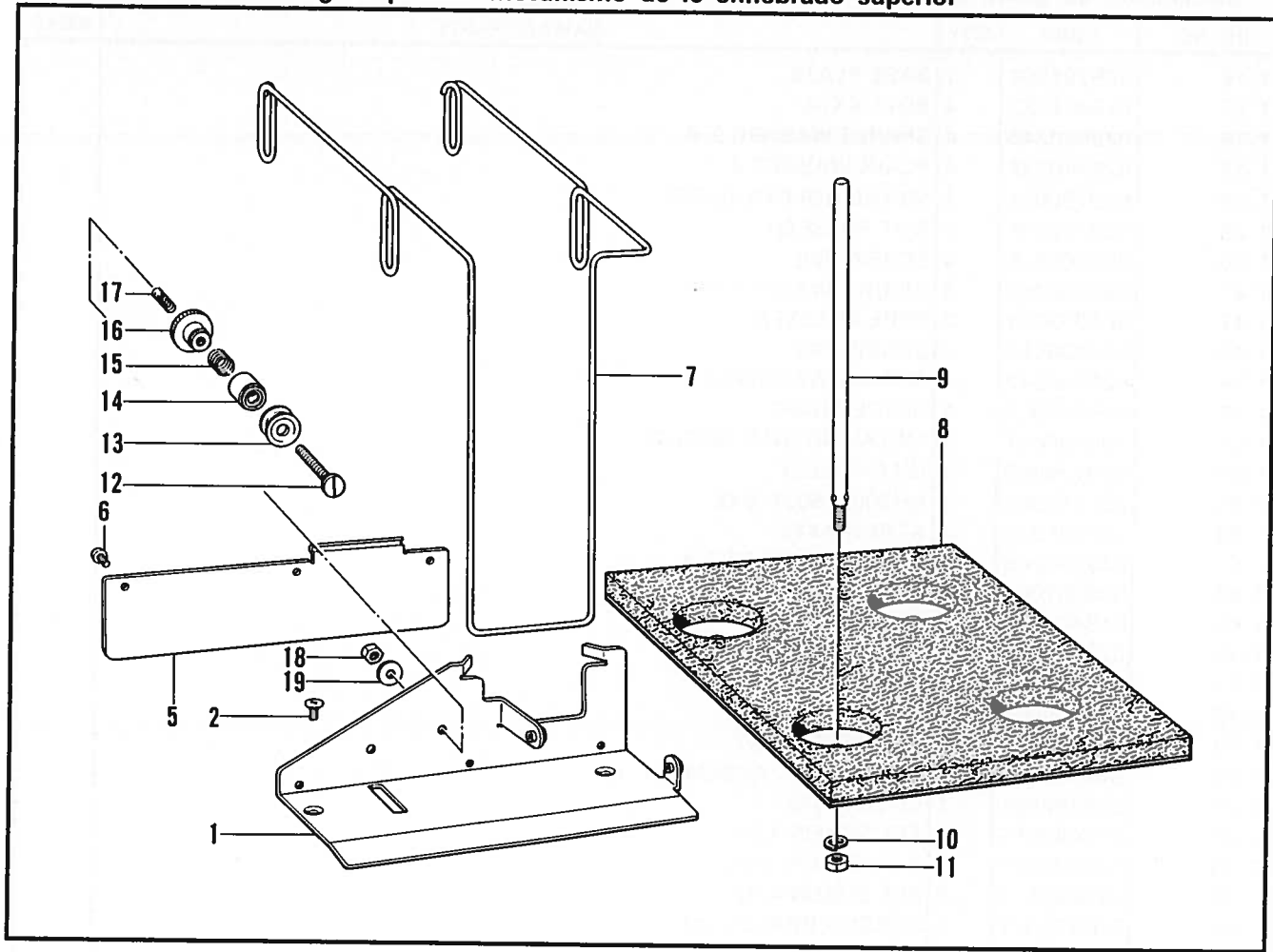

S. Programmer device/Programmvorrichtung/Dispositif du programmeur/Programadora

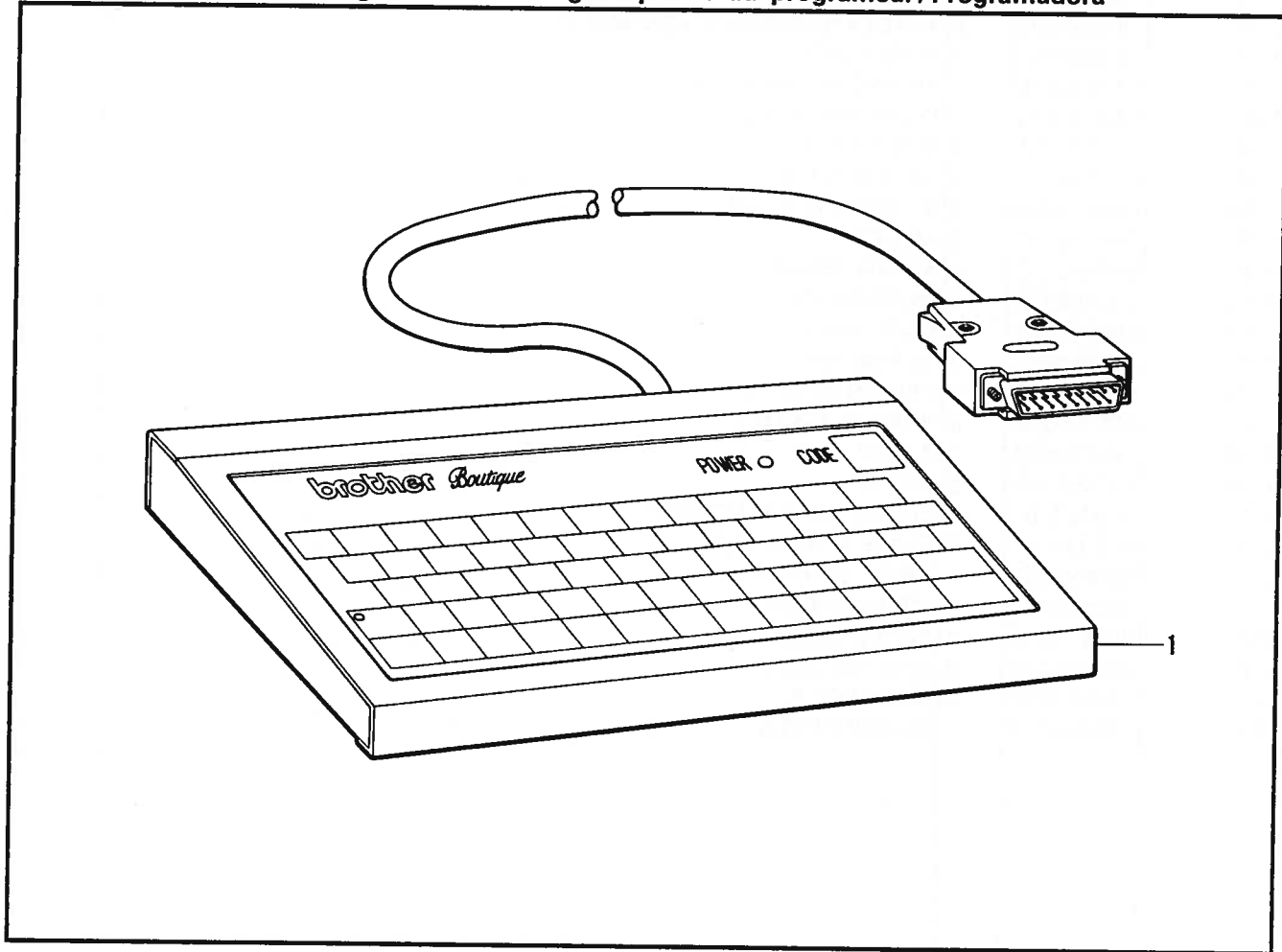

**R. Upper threading mechanism/Oberer fadens/  
Mécanisme de lénfilage supérieur/Mecanismo de le enhebrado superior**

REF.NO.	CODE	Q'TY	NAME OF PARTS	RMKS
1	S09838101	1	THREAD GUIDE BRACKET ASSEMBLY	
2	006402504	2	SCREW 4X25	
5	S09799001	1	SPOOL HOLDER COVER	
6	008300415	3	SCREW 3X4	
7	S09822001	1	THREAD GUIDE	
8	S09793000	1	SPOOL MAT	
9	150179002	4	SPOOL SHAFT (B)	
10	028050242	4	SPRING WASHER 2-5	
11	021500103	4	NUT 1-5	
12	153111001	1	PRE-TENSION STUD	
13	144504001	2	THREAD GUIDE DISC	
14	146206001	1	WASHER	
15	146058001	1	PRE-TENSION SPRING	
16	146059001	1	PRE-TENSION NUT	
17	146060000	1	SPRING	
18	105234003	1	NUT 4.37	
19	025680232	1	PLAIN WASHER 4.37	

**S. Programmer device/Programmvorrichtung/Dispositif du programmeur/Programadora**

REF.NO.	CODE	Q'TY	NAME OF PARTS	RMKS
1	S09876001	1	KYE BOARD ASSEMBLY (A)	
1	S15823001	1	KYE BOARD ASSEMBLY (B)	

T. Power table mechanism/Motorgestell/  
 Mécanisme du plateau de la machine/Mecanismo del mesa de la máquina

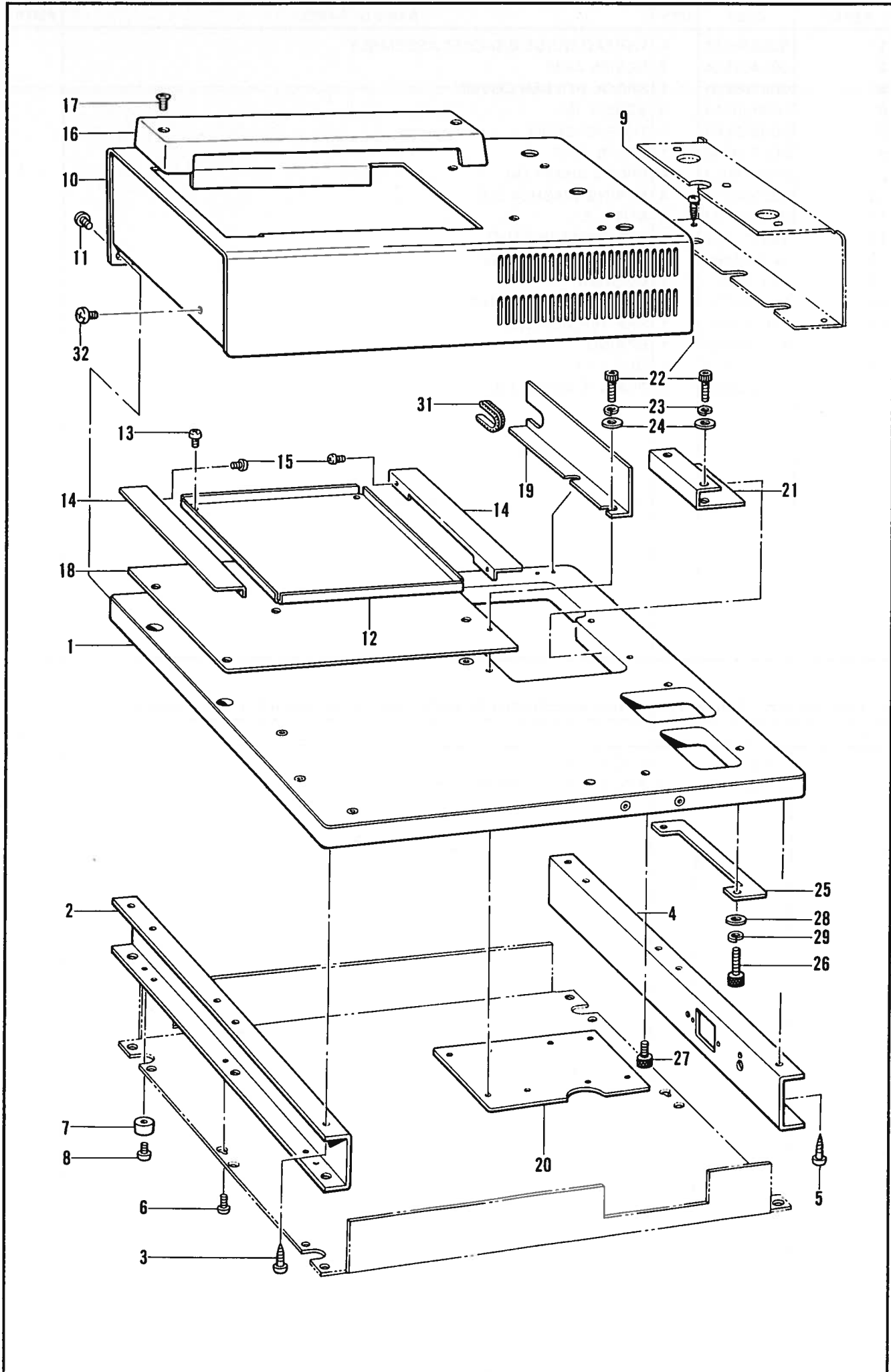

T. Power table mechanism/Motorgestell/  
Mécanisme du plateau de la machine/Mecanismo del mesa de la máquina

REF.NO.	CODE	Q'TY	NAME OF PARTS	RMKS
1	S09813200	1	TABLE	
2	S09805001	1	FRAME (LEFT)	
3	031451606	3	SCREW 4.5X16	
4	S09806001	1	FRAME (RIGHT)	
5	031451606	3	SCREW 4.5X16	
6	060400516	6	SCREW M4X5	
7	S09834000	4	RUBBER LEG	
8	062300505	4	SCREW 3X5	
9	032361606	2	SCREW 3.5X16	
10	S09810101	1	XY FEED UNIT COVER	
11	008400806	4	SCREW 4X8	
12	S09804001	1	COVER (U)	
13	008300604	4	SCREW 3X6	
14	S09792001	2	COVER (US)	
15	008300604	4	SCREW 3X6	
16	S09794100	1	SLIDE COVER	
17	004401003	2	SCREW 4X10	
18	S09821000	1	SHIELD PLATE	
19	S09798101	1	SCREEN COVER	
20	S09801001	1	TRANS FIXING PLATE	
21	S09841000	1	EARTH PLATE (1)	
22	018402522	4	BOLT 4X25	
23	028040242	4	SPRING WASHER 2-4	
24	025040232	4	PLAIN WASHER 4	
25	S09789000	1	EARTH PLATE (2)	
26	018502512	2	BOLT 5X25	
27	018501612	1	BOLT 5X16	
28	028050242	3	SPRING WASHER 2-5	
29	025050232	3	PLAIN WASHER 5	
31	S00469000	1	NYLON BUSHING	
32	008400418	1	SCREW 4X4	

U. Power supply equipment (II) / Stromversorgung (II) /  
 Mécanisme de léquipement en alimentation électrique (II) /  
 Mecanismo de la equipo de alimentación de corriente (II)

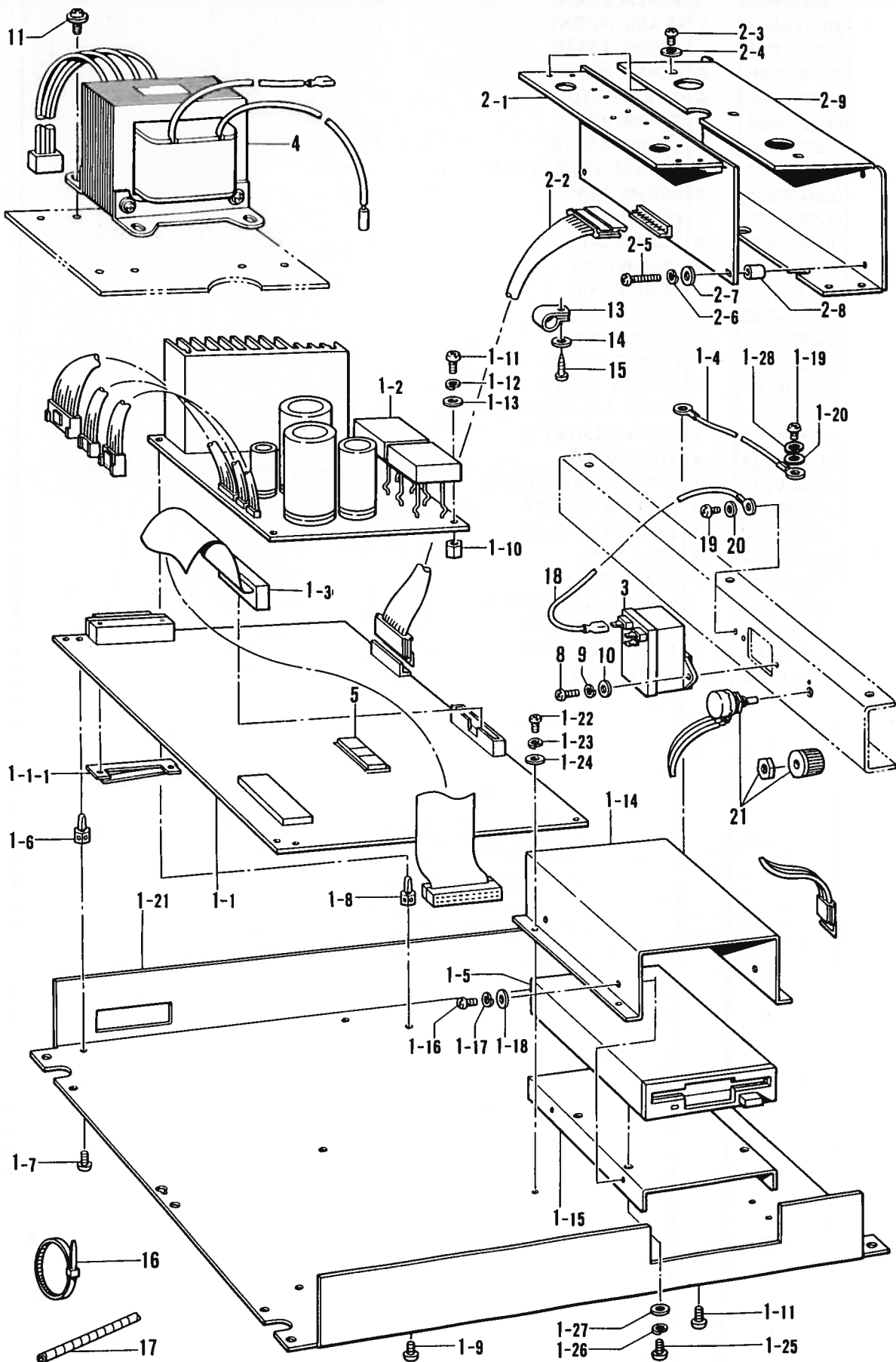



**U. Power supply equipment (II)/Stromversorgung (II)/  
Mécanisme de léquipement en alimentation électrique (II)/  
Mecanismo de la equipo de alimentación de corriente (II)**

REF.NO.	CODE	Q'TY	NAME OF PARTS	RMKS
1	S09996001	1	MAIN BASE ASSEMBLY	
1-1	S09938101	1	MAIN CIRCUIT BOARD ASSEMBLY	
1-1-1	S09814001	1	PLATE	
1-2	S09940001	1	POWER CIRCUIT BOARD ASSEMBLY	
1-3	S09984001	1	FDD CABLE ASSEMBLY	
1-4	S09983001	1	EARTH CORD (C) ASSEMBLY	
1-5	S09968000	1	3.5 INCH FDD	
1-6	S09982000	4	TAPPING SUPPORT	
1-7	037350615	5	SCREW TAPPING 3.5 X 6	
1-8	S09982000	4	TAPPING SUPPORT	
1-9	037350615	4	SCREW TAPPING 3.5 X 6	
1-10	S09753001	1	SPACER	
1-11	062300605	2	SCREW 3X6	
1-12	028030243	1	SPRING WASHER 2-3	
1-13	025030133	1	PLAIN WASHER 3	
1-14	S09803001	1	FDD BRACKET	
1-15	S09800001	1	FDD COVER	
1-16	062300605	4	SCREW 3X6	
1-17	028030243	4	SPRING WASHER 2-3	
1-18	025030133	4	PLAIN WASHER 3	
1-19	062300605	1	SCREW 3X6	
1-20	025030133	1	PLAIN WASHER 3	
1-21	S09809001	1	BASE COVER	
1-22	062300605	4	SCREW 3X6	
1-23	028030243	4	SPRING WASHER 2-3	
1-24	025030133	4	PLAIN WASHER 3	
1-25	062300605	4	SCREW 3X6	
1-26	028030243	4	SPRING WASHER 2-3	
1-27	025030133	4	PLAIN WASHER 3	
1-28	028030245	1	SPRING WASHER 2-3	
2	S09997001	1	PMD SIDE COVER ASSEMBLY	
2-1	S09928001	1	PMD CIRCUIT BOARD ASSEMBLY	
2-2	S09995001	1	PMD HARNESS ASSEMBLY	
2-3	062300605	3	SCREW 3X6	
2-4	025030133	3	PLAIN WASHER 3	
2-5	062301606	4	SCREW 3X16	
2-6	028030243	4	SPRING WASHER 2-3	
2-7	025030133	4	PLAIN WASHER 3	
2-8	S09754000	4	SPACER (C)	
2-9	S09808101	1	SIDE COVER	
3	S09961000	1	FILTER PLI-A0302	
5	S09882000	1	PROM 46 ASSEMBLY	
8	062300806	2	SCREW 3X8	
9	028030243	2	SPRING WASHER 2-3	
10	025030133	2	PLAIN WASHER 3	
11	533777001	4	SCREW 4X8DB	
13	525664000	3	CORD HOLDER #6	
14	025040235	3	PLAIN WASHER 4	
15	032361303	3	SCREW 3.5X13	
16	122772000	4	BAND	
17	S09853000	2	SPIRAL TUBE 200	
18	S09967001	1	EARTH CORD (B) ASSEMBLY	
19	062400505	1	SCREW M4X5	
20	025040235	1	PLAIN WASHER 4	
21	S09917001	1	LCDVR ASSEMBLY	
<hr/>				
<120V>				
4	S09963001	1	TRANS ASSEMBLY (US)	
<hr/>				
<220V>				
4	S09965001	1	TRANS ASSEMBLY (EC)	
<hr/>				
<240V>				
4	S09964001	1	TRANS ASSEMBLY (BS)	

V. Option parts/Sonderzubehör/Pieces en option/Piezas opcion

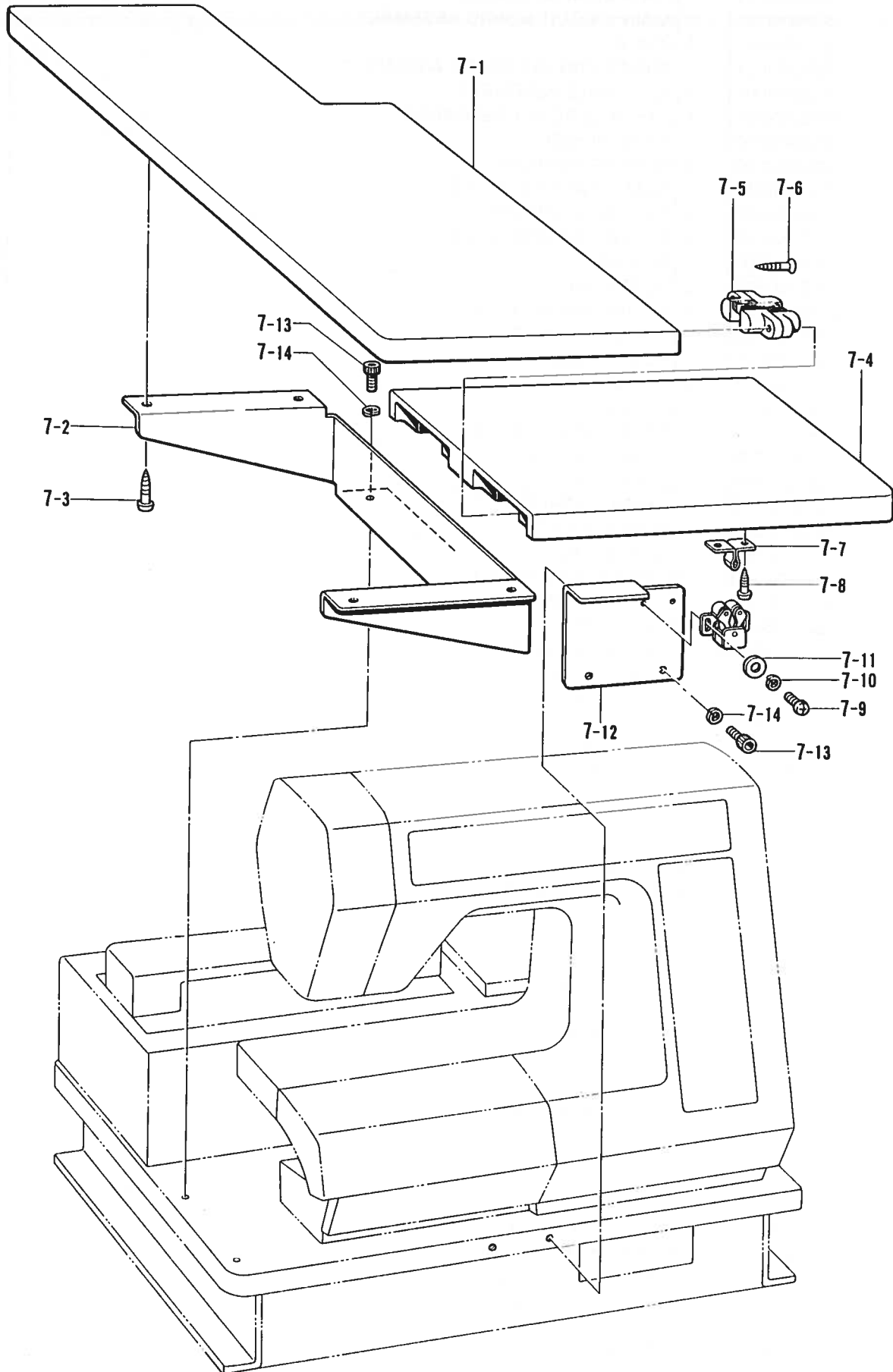

V. Option parts/Sonderzubehör/Pieces en option/Piezas opcion

REF.NO.	CODE	Q'TY	NAME OF PARTS	RMKS
7	S10002000	1	AUXILIARY TABLE ASSEMBLY	
7-1	S10003000	1	TABLE (A)	
7-2	S10005001	1	STAY (A)	
7-3	032461606	4	SCREW 4.5X16	
7-4	S10004000	1	TABLE (B)	
7-5	S04929000	2	HINGE	
7-6	034422006	4	SCREW 4X20	
7-7	S10007000	1	ROLLER CATCH	
7-8	032361303	2	SCREW 3.5X13	
7-9	062300605	2	SCREW 3X6	
7-10	028030245	2	PRING WASHER 2-3	
7-11	025030235	2	WASHER 3	
7-12	S10006001	1	BRACKET	
7-13	018401022	5	BOLT 4X10	
7-14	028040242	5	SPRING WASHER 4	

Z. Accessories / Zubehör / Accessoires / Accesorios

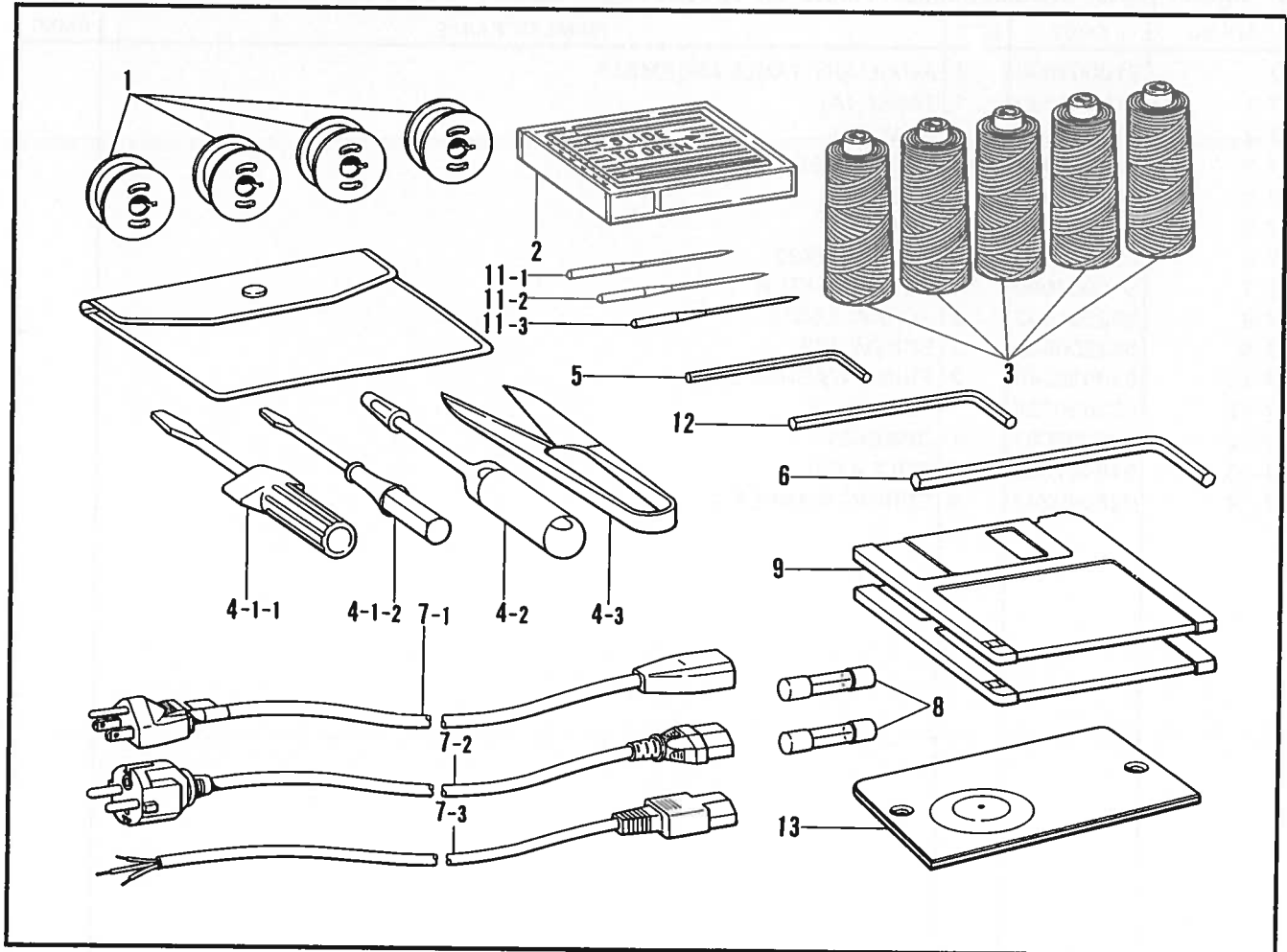

**Z. Accessories / Zubehör / Accessoires / Accesorios**

REF.NO.	CODE	Q'TY	NAME OF PARTS	RMKS
1	137489001	4	BOBBIN (FOR SENSOR)	
2	S09731001	1	Z NEEDLE ASSEMBLY	
3	S09819000	1	THREAD SAMPLE ASSEMBLY	
4	S09724001	1	ACCESSORY ASSEMBLY	
4-1-1	130614001	1	SCREW DRIVER (M)	
4-1-2	180109001	1	SCREW DRIVER (S)	
4-2	129099001	1	OILER (D) ASSEMBLY	
4-3	184430001	1	SCISSOR	
5	146049001	1	HEXAGONAL WRENCH 2	
6	150335001	1	HEXAGONAL WRENCH 5	
8	S09994000	2	G FUSE SD 6-3A-N1	
9	S15177001	1	ALPHABETICAL ASSEMBLY	
11-1	100028111	10	NEEDLE (#11)	
11-2	100028114	10	NEEDLE (#14)	
11-3	100028009	10	NEEDLE (#9)	
12	142721001	1	HEXAGONAL WRENCH 3	
13	S09749001	1	NEEDLE PLATE	
<b>&lt;120V&gt;</b>				
7-1	U24695001	1	POWER SUPPLY CORD ASSEMBLY (UL)	
<b>&lt;220V&gt;</b>				
7-2	U24697001	1	POWER SUPPLY CORD ASSEMBLY (VDE)	
<b>&lt;240V&gt;</b>				
7-3	S09986001	1	POWER SUPPLY CORD (BS)	

**FLOPPY LIST/DISKETTENLISTE/  
LISTE DE DISQUETTE/LISTA DE DISCOS FLEXIBLES**

Name of Parts		Parts No.
Alphabetical Assembly	for 28 Characters	S15177-001
One Point Floppy Assembly	for 2,000 Stitches	S09991-001
One Point Floppy Assembly	for 4,000 Stitches	S09991-002
One Point Floppy Assembly	for 6,000 Stitches	S09991-003
One Point Floppy Assembly	for 8,000 Stitches	S09991-004
One Point Floppy Assembly	for 10,000 Stitches	S09991-005
One Point Floppy Assembly	for 12,000 Stitches	S09991-006
One Point Floppy Assembly	for 15,000 Stitches	S09991-007
One Point Data Conversion	for 2,000 Stitches	S09998-001
One Point Data Conversion	for 4,000 Stitches	S09998-002
One Point Data Conversion	for 6,000 Stitches	S09998-003
One Point Data Conversion	for 8,000 Stitches	S09998-004
One Point Data Conversion	for 10,000 Stitches	S09998-005
One Point Data Conversion	for 12,000 Stitches	S09998-006
One Point Data Conversion	for 15,000 Stitches	S09998-007
Design Floppy 1 Assembly	for Sports Design Floppy 1 Sports sheet	S15174-201 S15897-001 192405-061
Design Floppy 2 Assembly	for Flower, Animal, Constellation Design Floppy 2 Animal sheet	S15175-201 S15898-001 192405-071
Design Frame Assembly	Design Frame Frame sheet	S15178-201 S15900-001 192405-081
New Character Floppy Assembly	for 1 Characters	S09999-001
New Character Floppy Assembly	for 2 Characters	S09999-002
New Character Floppy Assembly	for 3 Characters	S09999-003
New Character Floppy Assembly	for 4 Characters	S09999-004
New Character Floppy Assembly	for 5 Characters	S09999-005
New Character Floppy Assembly	for 6 Characters	S09999-006
New Character Floppy Assembly	for 7 Characters	S09999-007
New Character Floppy Assembly	for 8 Characters	S09999-008
New Character Floppy Assembly	for 9 Characters	S09999-009
New Character Floppy Assembly	for 10 Characters	S09999-010
Register Floppy Assembly		S10008000

INDEX / LEHRENLISTE / INDEX / INDICE

CODE	REF.NO.	PAGE
S00469000	T - 31	26
S00470000	P - 30	18
S04929000	V - 7-5	30
S09693001	C - 4	4
S09695001	C - 15	4
S09696001	D - 13	6
S09697001	D - 14	6
S09699101	D - 21	6
S09700001	D - 22	6
S09701001	D - 23	6
S09702001	D - 31	6
S09703001	E - 1	8
S09704001	E - 1-2	8
S09706001	H - 4	12
S09707001	J - 1	12
S09708001	K - 1	14
S09712001	K - 3	14
S09713101	P - 36	18
S09714001	P - 37	18
S09715001	K - 7	14
S09716001	K - 7-1	14
S09719001	K - 7-2	14
S09720001	P - 41	18
S09722001	A - 10	2
S09723001	A - 22	2
S09724001	Z - 4	32
S09725001	G - 1	10
S09727001	A - 11	2
S09728000	B - 6	4
S09731001	Z - 2	32
S09742001	H - 4-1	12
S09744001	A - 5	2
S09745001	C - 16	4
S09746000	A - 25	2
S09747000	A - 26	2
S09748001	H - 4-2	12
S09749001	Z - 13	32
S09752001	P - 23	18
S09753001	U - 1-10	28
S09754000	U - 2-8	28
S09755001	Q1- 1-26	20
	Q2- 1-72	22
S09756001	Q2- 1-74	22
S09759001	Q1- 1-28	20
S09761001	Q1- 1-36	20
S09765001	Q1- 1-31	20
S09768001	Q1- 1-47	20
S09770001	Q1- 1-56	20
	Q2- 1-78	22
S09771000	Q1- 1-77	20
S09772001	Q2- 1-39	22
S09773001	Q2- 1-42	22
S09774001	Q1- 1-35	20
	Q1- 1-51	20
S09775000	Q2- 1-55	22
S09776001	Q2- 1-52	22
S09777000	Q2- 1-90	22
S09778001	Q1- 1-45	20
S09779000	Q2- 1-98	22
S09780001	Q2- 1-94	22
S09781001	Q1- 1-58	20
S09782100	Q2- 1-91	22
S09783000	P - 11	18
	P - 18	18
S09784000	P - 17	18
S09785001	Q2- 1-80	22
S09788001	Q2- 1-75	22

CODE	REF.NO.	PAGE
S09789000	T - 25	26
S09790001	Q1- 1-20	20
S09791001	Q2- 1-16	22
S09792001	T - 14	26
S09793000	R - 8	24
S09794100	T - 16	26
S09795001	Q2- 1-38	22
S09796001	Q2- 1-54	22
S09797101	Q2- 1-88	22
S09798101	T - 19	26
S09799001	R - 5	24
S09800001	U - 1-15	28
S09801001	T - 20	26
S09802001	Q1- 1-14	20
S09803001	U - 1-14	28
S09804001	T - 12	26
S09805001	T - 2	26
S09806001	T - 4	26
S09807001	Q2- 1-68	22
S09808101	U - 2-9	28
S09809001	U - 1-21	28
S09810101	T - 10	26
S09811101	Q1- 1-6	20
S09812101	Q1- 1-1	20
S09813200	T - 1	26
S09814001	U - 1-1-1	28
S09819000	Z - 3	32
S09820000	P - 34	18
S09821000	T - 18	26
S09822001	R - 7	24
S09823101	Q2- 2-1	22
S09827001	Q2- 2-3	22
S09828101	Q2- 2-4	22
S09830100	Q2- 2-2	22
S09831100	B - 9	4
S09832101	P - 24	18
S09834000	T - 7	26
S09835000	Q1- 1-29	20
S09836000	Q1- 1-30	20
S09837100	Q2- 2-8	22
S09838101	R - 1	24
S09840001	Q1- 1-2	20
S09841000	T - 21	26
S09842101	Q1- 1-10	20
S09843201	L - 1-1	14
S09844201	L - 1-2	14
S09845201	L - 1-3	14
S09846201	L - 1-4	14
S09847201	L - 1-5	14
S09848001	L - 5	14
S09849001	Q1- 1	20
S09850001	P - 33	18
S09853000	U - 17	28
S09855000	B - 3	4
S09876001	S - 1	24
S09882000	U - 5	28
S09901001	P - 6	18
S09906001	P - 7	18
S09908101	P - 8	18
S09910001	P - 1	18
S09912101	P - 2	18
S09914001	P - 3	18
S09916001	P - 4	18
S09917001	U - 21	28
S09919001	P - 9	18
S09928001	U - 2-1	28
S09933001	Q2- 1-84	22

CODE	REF.NO.	PAGE
S09936001	Q1- 1-61	20
S09938101	U - 1-1	28
S09940001	U - 1-2	28
S09961000	U - 3	28
S09963001	U - 4	28
S09964001	U - 4	28
S09965001	U - 4	28
S09966001	P - 10	18
S09967001	U - 18	28
S09968000	U - 1-5	28
S09982000	U - 1-6	28
	U - 1-8	28
S09983001	U - 1-4	28
S09984001	U - 1-3	28
S09986001	Z - 7-3	32
S09992100	P - 5	18
S09994000	Z - 8	32
S09995001	U - 2-2	28
S09996001	U - 1	28
S09997001	U - 2	28
S10002000	V - 7	30
S10003000	V - 7-1	30
S10004000	V - 7-4	30
S10005001	V - 7-2	30
S10006001	V - 7-12	30
S10007000	V - 7-7	30
S15177001	Z - 9	32
S15823001	S - 1	24
U06923001	P - 16	18
	P - 31	18
	P - 44	18
U24695001	Z - 7-1	32
U24697001	Z - 7-2	32
X51383000	G - 1-11	10
Z22710001	Q2- 1-65	22
Z22720001	Q1- 1-23	20
004401003	T - 17	26
006402504	R - 2	24
008300415	R - 6	24
008300604	T - 13	26
	T - 15	26
008400418	T - 32	26
008400806	T - 11	26
009689412	D - 15	6
013400814	A - 21-10	2
013680512	Q1- 1-27	20
	Q1- 1-46	20
	Q1- 1-57	20
	Q2- 1-73	22
	Q2- 1-76	22
	Q2- 1-79	22
013681012	G - 1-14-3	10
014300332	C - 15-1	4
014400822	Q1- 1-37	20
	Q1- 1-53	20
	Q2- 1-89	22
014400832	G - 1-27	10
018061222	Q1- 1-7	20
018061622	Q1- 1-11	20
018400822	H - 3	12
018401022	Q1- 1-32	20
	Q1- 1-48	20
	Q2- 1-69	22
	V - 7-13	30
018401222	Q1- 1-21	20
	Q2- 1-17	22
018402522	T - 22	26

CODE	REF.NO.	PAGE
018501612	T - 27	26
018502512	T - 26	26
018503022	Q1- 1-3	20
021300103	N - 8	16
021400102	Q2- 1-99	22
021400202	C - 14	4
021500103	R - 11	24
021670403	K - 7-6	14
025030133	N - 10	16
	P - 14	18
	P - 22	18
	P - 26	18
	P - 29	18
	P - 32	18
	U - 1-13	28
	U - 1-18	28
	U - 1-20	28
	U - 1-24	28
	U - 1-27	28
	U - 10	28
	U - 2-4	28
	U - 2-7	28
025030135	Q1- 1-64	20
	Q2- 1-87	22
025030233	N - 7	16
	Q2- 1-97	22
025030235	V - 7-11	30
025030336	A - 22-2-8	2
025040133	A - 22-5	2
025040232	H - 5	12
	P - 49	18
	Q1- 1-34	20
	Q1- 1-50	20
	Q2- 1-19	22
	Q2- 1-71	22
	T - 24	26
025040235	U - 14	28
	U - 20	28
025050232	T - 29	26
025060232	Q1- 1-13	20
	Q1- 1-9	20
025350233	Q2- 1-93	22
	Q2- 2-7	22
025680232	R - 19	24
026030234	P - 40	18
026060235	E - 6	8
028030242	Q2- 1-44	22
	Q2- 1-82	22
028030243	P - 13	18
	P - 21	18
	U - 1-12	28
	U - 1-17	28
	U - 1-23	28
	U - 1-26	28
	U - 2-6	28
	U - 9	28
028030245	Q1- 1-60	20
	Q1- 1-63	20
	Q2- 1-41	22
	Q2- 1-86	22
	Q2- 1-96	22
	U - 1-28	28
	V - 7-10	30
028040242	T - 23	26
	V - 7-14	30
028040245	Q1- 1-22	20
	Q1- 1-25	20



CODE	REF.NO.	PAGE
028040245	Q1- 1-33	20
	Q1- 1-49	20
	Q2- 1-18	22
	Q2- 1-67	22
	Q2- 1-70	22
028050242	Q1- 1-4	20
	R - 10	24
	T - 28	26
028060242	Q1- 1-12	20
	Q1- 1-8	20
028350242	K - 7-7	14
028350243	Q2- 2-6	22
031451606	T - 3	26
	T - 5	26
032361303	U - 15	28
	V - 7-8	30
032361606	T - 9	26
032461606	V - 7-3	30
034422006	V - 7-6	30
037350615	U - 1-7	28
	U - 1-9	28
047251442	G - 1-8	10
047251642	C - 1-9	4
047302242	C - 1-4	4
048020346	N - 3	16
	P - 38	18
	G - 1-26	10
048025346	D - 5	6
048030346	E - 1-3	8
048050346	C - 1-2	4
	C - 2	4
060300416	G - 1-29	10
060300616	A - 22-4	2
	K - 14	14
	K - 4	14
	K - 6	14
	P - 39	18
	P - 42	18
	P - 47	18
	A - 14	2
	K - 7-5	14
	T - 6	26
	A - 3	2
D - 24	6	
E - 3	8	
J - 2	12	
K - 12	14	
P - 35	18	
060400816	Q1- 1-15	20
060401015	G - 1-17	10
	G - 1-5	10
060401016	C - 10	4
	C - 13	4
	G - 2	10
060601216	A - 23	2
061300416	P - 46	18
062063016	C - 5	4
062300405	N - 9	16
	P - 25	18
	P - 43	18
	Q2- 1-81	22
062300502	N - 6	16
	P - 28	18
	P - 50	18
	Q1- 1-62	20
	Q2- 1-40	22
	Q2- 1-85	22

CODE	REF.NO.	PAGE
062300505	T - 8	26
	062300605	U - 1-11
062300605	U - 1-16	28
	U - 1-19	28
	U - 1-22	28
	U - 1-25	28
	U - 2-3	28
	V - 7-9	30
	062300612	Q2- 1-43
062300805	Q2- 1-95	22
062300806	P - 12	18
	P - 20	18
	U - 8	28
062301205	P - 19	18
	062301606	Q1- 1-31-1
	Q1- 1-47-1	20
	Q1- 1-59	20
	U - 2-5	28
062301616	A - 6	2
062400505	U - 19	28
062401016	Q1- 1-24	20
	Q2- 1-66	22
062402005	Q2- 1-83	22
062402016	F - 3	8
062671014	Q2- 2-5	22
062672012	Q2- 1-92	22
100028009	Z - 11-3	32
100028111	D - 32	6
	Z - 11-1	32
100028114	Z - 11-2	32
100139001	D - 27	6
100251001	C - 6	4
100507000	D - 16	6
102571003	J - 1-4	12
102707003	D - 8	6
103408002	G - 1-13	10
	G - 1-23	10
105234003	R - 18	24
115000000	A - 24	2
117851001	A - 17	2
120263001	J - 1-3	12
120448001	J - 1-2-1	12
122772000	U - 16	28
123006001	C - 7	4
123185001	D - 6	6
123840001	E - 1-1	8
124059001	K - 10	14
124241001	K - 8	14
125161000	D - 30	6
129099001	Z - 4-2	32
129376001	K - 9	14
129825001	A - 21-3	2
129826001	A - 21-4	2
129837001	D - 1-2	6
129838001	D - 1-3	6
129839001	D - 1-4	6
129840001	D - 9	6
129847001	D - 2	6
129849001	D - 11	6
129853001	D - 28	6
129935000	A - 21-5	2
129983001	A - 21-6	2
130006001	K - 2	14
130128001	A - 15	2
130146003	A - 21-1	2
130614001	Z - 4-1-1	32
131226001	D - 29	6

CODE	REF.NO.	PAGE
131281001	D - 1-6	6
131282001	D - 1-5	6
131976000	C - 3	4
132051001	D - 17	6
132231001	A - 2	2
132232002	A - 4	2
132253001	A - 20	2
132257001	A - 19	2
132259002	A - 22-1	2
132266002	C - 1-1	4
132269000	C - 1-3	4
132271000	C - 1-6	4
132272000	C - 1-8	4
132277001	C - 9	4
132278001	C - 11	4
132289001	C - 12	4
132305000	K - 7-4	14
132312001	J - 1-1	12
132313001	J - 1-2	12
132387001	K - 11	14
132420000	G - 1-9	10
132421001	G - 1-15	10
132422000	G - 1-6	10
132433001	G - 1-12	10
132436000	G - 1-4	10
132437001	G - 1-18	10
132439001	G - 1-22	10
132448000	G - 1-21	10
132470001	F - 2	8
132881001	A - 22-3	2
132994001	G - 1-19	10
135525001	A - 12	2
135553001	G - 1-14-4	10
135622001	G - 1-20	10
136423001	D - 3	6
136503003	A - 21	2
136505001	A - 21-9	2
136507001	A - 13	2
136511005	A - 22-2	2
136512005	A - 22-2-1	2
136513001	A - 22-2-2	2
136514001	A - 22-2-3	2
136515001	A - 22-2-6	2
136516001	A - 22-2-5	2
136535001	A - 7	2
136536001	D - 25	6
136537001	C - 1-5	4
136540001	D - 1	6
136541000	D - 1-1	6
136542001	D - 4	6
136543001	D - 7	6
136544001	D - 19	6
136548000	E - 2	8
136557000	F - 1	8
136560001	J - 1-5	12
136562001	E - 5	8
136563001	H - 2	12
136572001	K - 5	14
136578001	K - 7-3	14
136579001	K - 13	14
136582001	M - 1	16
136611001	A - 9	2
136613001	G - 1-1	10
136629000	G - 1-2	10
136630000	G - 1-10	10
136631000	G - 1-7	10
136633000	G - 1-14-1	10

CODE	REF.NO.	PAGE
136634001	G - 1-14-2	10
136636000	G - 1-3	10
136638001	G - 1-25	10
136639001	G - 1-16	10
136657001	G - 1-24	10
136660000	G - 1-28	10
136681001	A - 21-7	2
	A - 22-2-4	2
136813001	A - 21-2	2
136846001	E - 4	8
136851001	P - 45	18
	P - 48	18
136869001	A - 22-2-7	2
136893001	P - 15	18
136894001	C - 1-10	4
137272001	A - 18	2
137286001	P - 51	18
137489001	H - 6	12
	Z - 1	32
137493001	H - 1	12
138011001	K - 7-8	14
142721001	Z - 12	32
144504001	R - 13	24
146049001	Z - 5	32
146058001	R - 15	24
146059001	R - 16	24
146060000	R - 17	24
146206001	R - 14	24
150179002	R - 9	24
150335001	Z - 6	32
151602002	D - 12-1	6
153111001	R - 12	24
157255000	N - 1	16
157256001	N - 5	16
157262001	N - 2	16
157263001	N - 4	16
157340101	L - 7	14
180109001	Z - 4-1-2	32
182702000	D - 12	6
184388001	C - 1	4
184430001	Z - 4-3	32
215616000	C - 1-7	4
	C - 8	4
233297001	M - 3	16
513159001	A - 21-8	2
523323001	A - 16	2
525664000	P - 27	18
	U - 13	28
533777001	D - 18	6
	U - 11	28
537235001	M - 2	16



**brother**