

brother

BAS-510

連続前立穴かがり機

AUTOMATIC LOCKSTITCH BUTTON HOLER

AUTOMATISCHE KNOPFLOCHNÄHMASCHINE

UNITE DE COUTURE AUTOMATIQUE DE BOUTONNIERES

APARATO AUTOMATICO DE COSER OJALES

パーツブック

PARTS BOOK

TEILEKATALOG

LIVRE DES PIECES

LIBRO DE REFERENCIA DE PIEZAS

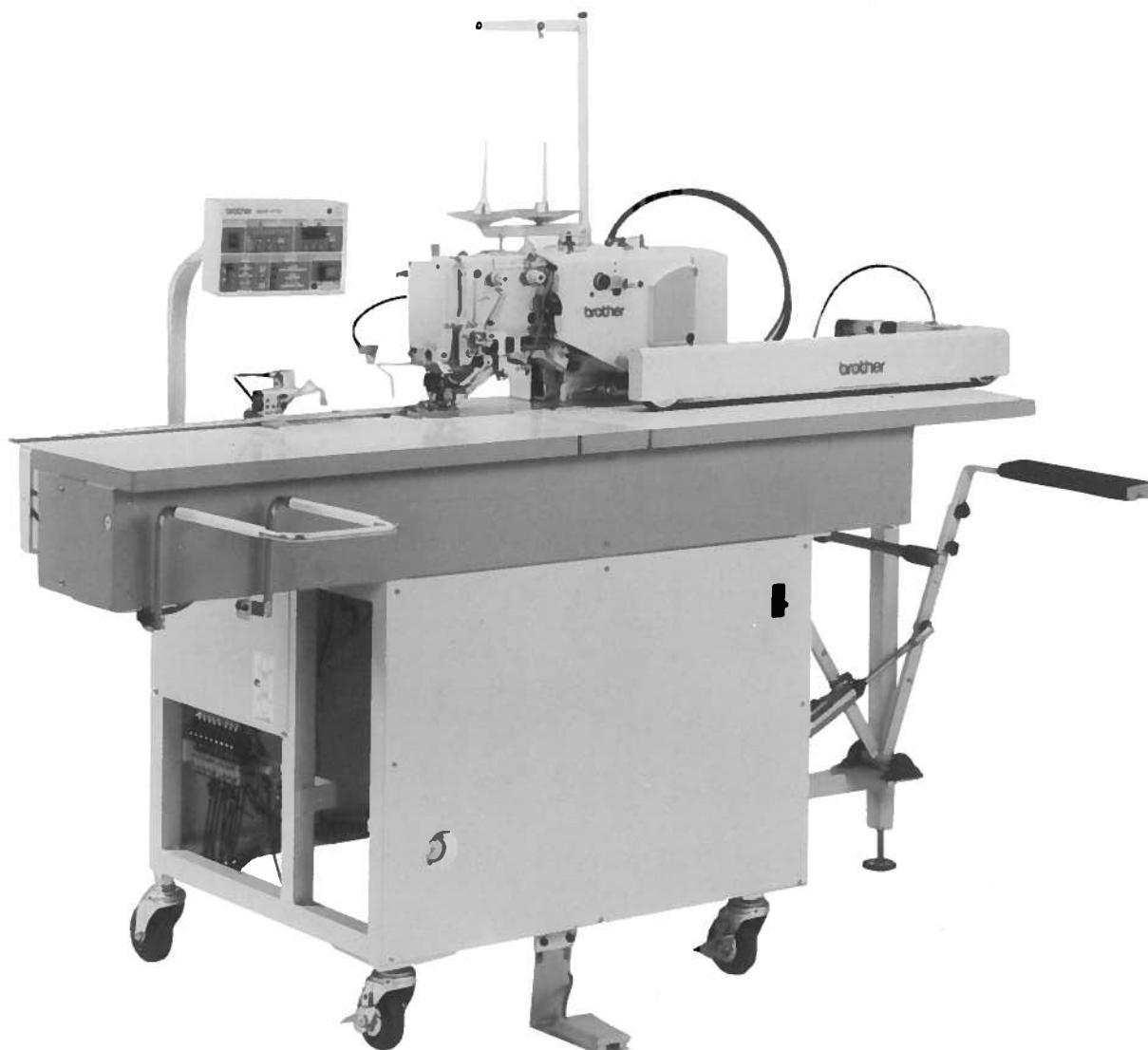

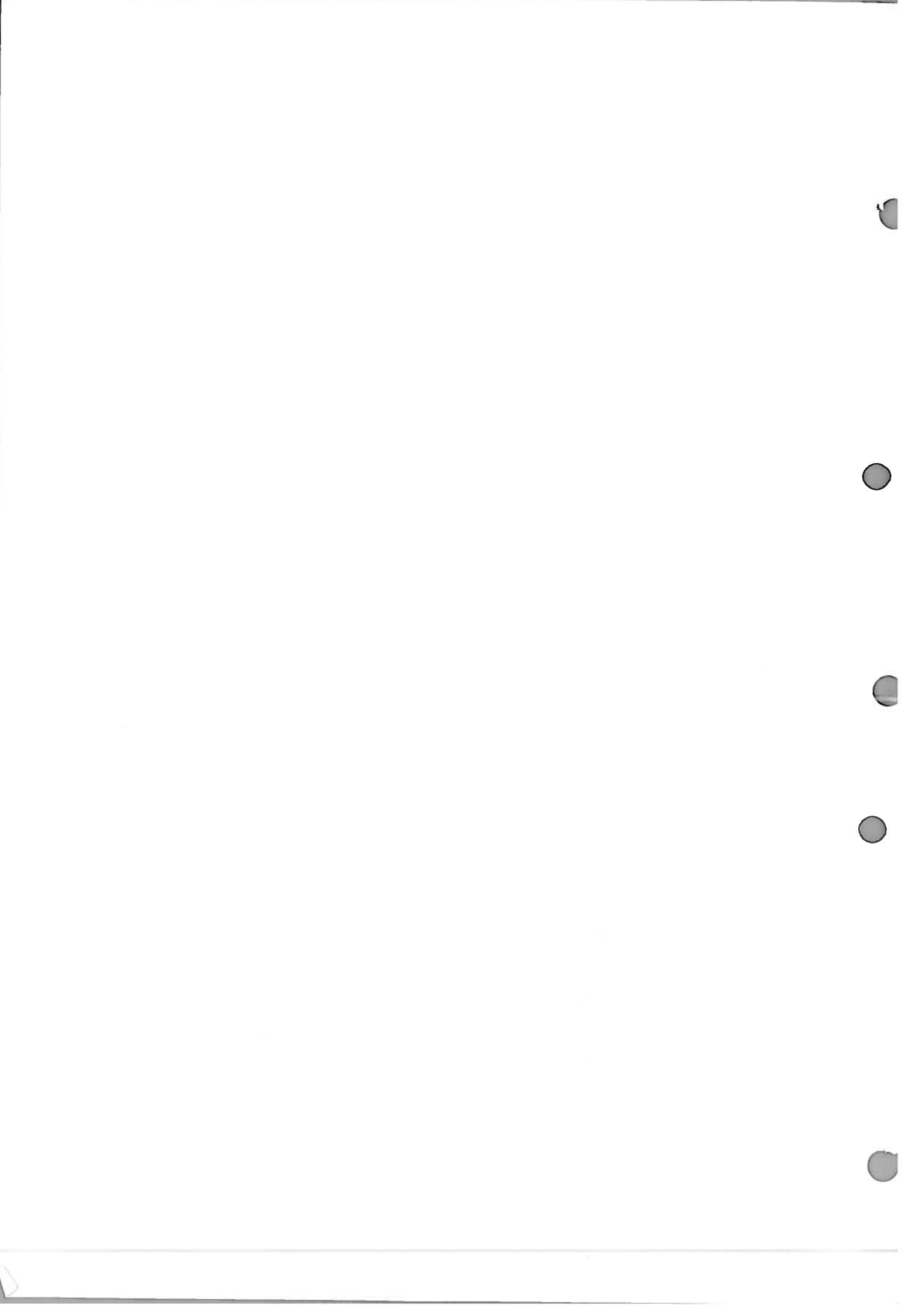

パーツブックご利用に際して

1. この本は1990年12月のデータに基づいて作成されたものです。
2. 組単位で補給する部品は、 破線で示しております。
3. 部品は予告なしに設計変更される場合があります。
4. 部品コード欄が*となっている場合は、仕様別部品一覧表（79ページ）でお調べ下さい。

目 次

A. 主体関係	2	T. 糸巻装置	42
B. 針棒関係	6	U. 減速関係	42
C. 上軸関係	8	V. 上糸切り関係	44
D. 針振関係	10	W. 下糸切り関係	46
E. 停止関係	14	A1. スタッカー関係	48
F. ベルト寄せ関係	16	B1. コントロールボックス関係	52
G. テンションプーリ関係	16	C1. 空圧関係(1)	54
H. 押エ関係	18	C1. 空圧関係(2)	58
J. 送り関係	20	D1. 電装品関係(1)	60
K. カム伝導関係	24	D1. 電装品関係(2)	64
L. 糸切れ感知関係	24	E1. 布制御関係	66
M. カッター関係	26	F1. 動力台関係	72
N. カマ関係	30	Z. 付属品関係	76
P. 下軸関係	32	仕様別部品一覧表	79
Q. O P 頭部組付関係	32	ゲージ部品一覧表	80
R. 給油潤滑関係	34	索 引	82
S. 糸通シ関係	38		

Notes for using this parts book

1. This book was prepared based on information available in December 1990.
2. Parts supplied as complete assemblies are circled by a dotted line .
3. Parts are subject to changes in design without prior notice.
4. If the symbol * is found in the "Parts No." column, refer to the different parts list on page 81.

CONTENTS

A . Machine body	2	S . Threading mechanism	38
B . Needle bar mechanism	6	T . Bobbin winder	42
C . Upper shaft mechanism	8	U . Power transmitter mechanism	42
D . Zigzag mechanism	10	V . Upper thread trimmer mechanism	44
E . Clutch mechanism	14	W . Lower thread trimmer mechanism	48
F . Belt shift mechanism	16	A1. Stacker mechanism	50
G . Tension pulley mechanism	16	B1. Control box mechanism	54
H . Presser foot mechanism	18	C1. Air pressure mechanism (1)	56
J . Feed mechanism	20	C1. Air pressure mechanism (2)	60
K . Feed cam mechanism	24	D1. Power supply equipment mechanism (1) ..	62
L . Thread breakage detector mechanism	24	D1. Power supply equipment mechanism (2) ..	66
M . Cutter mechanism	26	E1. Cloth control system mechanism	68
N . Rotary hook mechanism	30	F1. Power table	74
P . Lower shaft mechanism	32	Z . Accessories	78
Q . Single pedal mechanism installed in the head	32	DIFFERENT PARTS LIST	81
R . Lubrication	34	GAUGE PARTS LIST	82
		INDEX	84

Hinweise zur Verwendung dieser Teileliste

1. Dieses Buch basiert auf den Informationen vom Dezember 1990.
2. Die Teile, die als kompletter Satz geliefert werden, sind mit einer gestrichelten Linie umrandet.
3. Modelländerungen sind vorbehalten.
4. Dieses Zeichen * in der Spalte "Parts No. (Teilnummer)" verweist auf die Gesonderte Stückliste auf Seite 81.

INHALTSVERZEICHNIS

A . Maschinengehäuse	2	T . Spuler	42
B . Nadelstangenvorrichtung	6	U . Kraftübertragungsvorrichtung	42
C . Obere Welle	8	V . Oberer Fadenabschneider	44
D . Zickzackvorrichtung	10	W . Unterer Fadenabschneider	48
E . Kupplungsvorrichtung	14	A1. Anhäufung	50
F . Riemenstellvorrichtung	16	B1. Schaltkasten	54
G . Spannrolle	16	C1. Luftdruck (1)	56
H . Stoffdrückerfuß	18	C1. Luftdruck (2)	60
J . Transportvorrichtung	20	D1. Stromversorgung (1)	62
K . Transporteurkurve	24	D1. Stromversorgung (2)	66
L . Fadenbruchfühler	24	E1. Stoffführungsvorrichtung	68
M . Abschneidevorrichtung	26	F1 . Motorgestell	74
N . Greifervorrichtung	30	Z . Zubehör	78
P . Untere Welle	32	ZUBEHÖRLISTE	81
Q . Maschineoberteil Mit Einem Pedal	32	LEHRENLISTE	82
R . Schmierung	34	VERZEICHNIS	84
S . Fadenführungsvorrichtung	38		

Notes sur l'utilisation de ce manuel de pièces détachées



1. Ce manuel a été fait d'après les renseignements valables au mois de Décembre 1990.
2. Les pièces fournies en tant qu'assemblages complets sont encadrées avec un trait pointillé .
3. Les pièces peuvent être sujettes à des modifications sans préavis.
4. Si le symbole * se trouve dans la colonne "Parts No. (N° de pièce)" veuillez la vous référer à la liste de pièces annexe page 81.

TABLE DES MATIERES

A . Corps de la machine 2	T . Mécanisme du bobineur 42
B . Mécanisme de la barre à aiguille 6	U . Mécanisme du transmetteur 42
C . Mécanisme de l'arbre supérieur 8	V . Mécanisme de la coupe-fil supérieur 44
D . Mécanisme du zigzag 10	W . Mécanisme de la coupe-fil inférieur 48
E . Mécanisme de l'embrayage 14	A1. Mécanisme de l'empileur 50
F . Mécanisme du changement de courroie 16	B1. Mécanisme du boîtier de contrôle 54
G . Mécanisme de la poulie de tension 16	C1. Mécanisme de la pression d'air (1) 56
H . Mécanisme du pied presseur 18	C1. Mécanisme de la pression d'air (2) 60
J . Mécanisme de l'entraînement 20	D1. Mécanisme de l'équipement en alimentation
K . Mécanisme de la came d'entraînement 24	électrique (1) 62
L . Mécanisme du détecteur de cassure	D1. Mécanisme de l'équipement en alimentation
du fil 24	électrique (2) 66
M . Mécanisme de la coupe 26	E1. Mécanisme de la système de contrôle du
N . Mécanisme du crochet rotatif 30	tissu 68
P . Mécanisme de l'arbre inférieur 32	F1. Mécanisme du plateau de la machine 74
Q . Mécanisme de l'ensemble de la tête pour	Z . Accessoires 78
une machine avec une seule pédale 32	LISTE DES PIECES ACCESSOIRES 81
R . Lubrification 34	LIST DES PIECES D'ECARTEMENT 82
S . Mécanisme de l'enfilage 38	INDEX 84

Notas para usar este Manual de Piezas

1. Este libro ha sido compilado basándose en los datos de que se disponía en diciembre 1990.
2. Las piezas suministradas como conjuntos completos se enmarcan con una línea punteada .
3. Las piezas quedan sujetas a cambios de diseño sin aviso previo.
4. De haber un símbolo * junto al "Parts No. (Número de Pieza)", habrá que mirar la lista de piezas separada de la página 81.

INDICE

A . Cuerpo de la máquina	2	U . Mecanismo del transmisor de potencia	42
B . Mecanismo de la barra de aguja	6	V . Mecanismo de la recortadura de hilos superior	44
C . Mecanismo del eje superior	8	W . Mecanismo de la recortadura de hilos inferior	48
D . Mecanismo del zigzag	10	A1. Mecanismo de apilador	50
E . Mecanismo del embrague	14	B1. Mecanismo de la caja de controles	54
F . Mecanismo de la transladación de correas	16	C1. Mecanismo de la presión de aire (1)	56
G . Mecanismo de la polea de tensión	16	C1. Mecanismo de la presión de aire (2)	60
H . Mecanismo de la prensatelas	18	D1. Mecanismo del equipo de alimentación de corriente (1)	62
J . Mecanismo de la alimentación	20	D1. Mecanismo del equipo de alimentación de corriente (2)	66
K . Mecanismo de la leva de alimentación	24	E1. Mecanismo de la sistema de control de tela	68
L . Mecanismo del sensor de cortes de hilo	24	F1 . Mecanismo de la mesa de la máquina	74
M . Mecanismo de la corta	26	Z . Accesorios	78
N . Mecanismo del cangrejo	30	LISTA DE PIEZAS ACCESORIAS	81
P . Mecanismo del eje inferior	32	LISTA DE PIEZAS CALIBRADORAS	82
Q . Mecanismo del conjunto de cabeza (de máquina) con pedal sencillo	32	INDICE	84
R . Lubricación	34		
S . Mecanismo del enhebrado	38		
T . Mecanismo del devanador de la canilla	42		

A. 主体関係 / Machine body / Maschinengehäuse /
 Corps de la machine / Cuerpo de la máquina

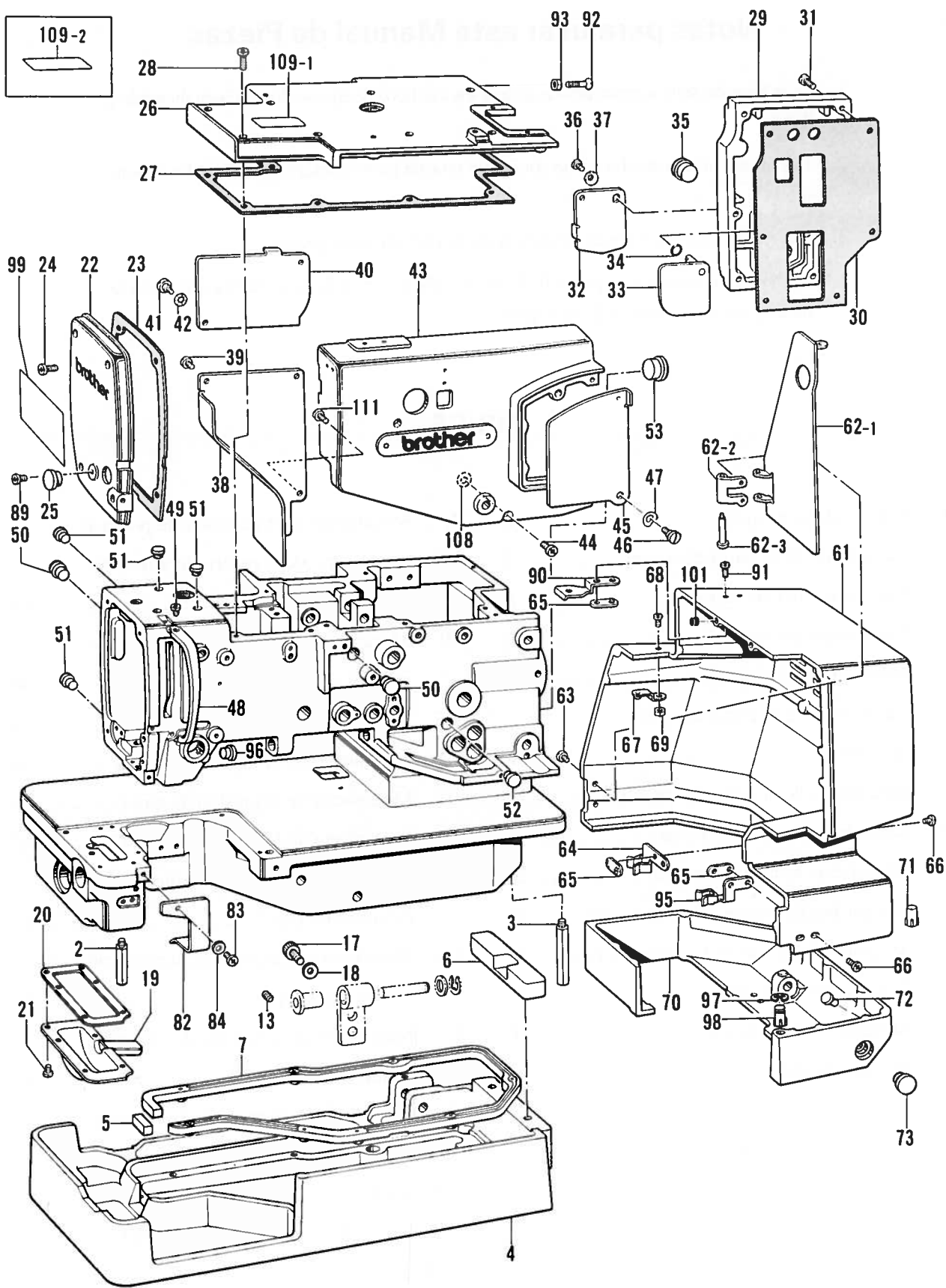
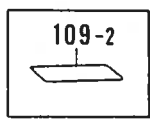

A. 主体関係 / Machine body / Maschinengehäuse /
Corps de la machine / Cuerpo de la máquina

REF.NO.	CODE	Q'TY	ヒンメイ	NAME OF PARTS	RMKS
2	151059001	1	ホンタイシチユウ	MACHINE BODY LEG	
3	113590001	3	ヘ"ツト"アシL	BED LEG (L)	
4	S19920009	1	ヘ"ツト"タイ	BED BASE	
5	S17062000	1	ヘ"ツト"タイクツシヨソ	BED BASE CUSHION	
6	159455109	1	ヘ"ツト"クツシヨソR	BED CUSHION (R)	
7	S15855009	1	ヘ"ツト"ウケゴ"ム	BED VESSEL RUBBER	
13	014760622	2	アナトメネシ"5.95	SET SCREW 5.95	
17	018061622	4	アナホ"ルト6X16	BOLT 6X16	
18	025060232	4	ヒラサ"カ"ネチユウ 6	PLAIN WASHER 6	
19	158833001	1	キ"ヤケースカハ"ー	GEAR CASE COVER	
20	158834000	1	キ"ヤケースカハ"ーハ"ツキン	GEAR CASE COVER PACKING	
21	062680812	6	ナヘ"コ437-40X8	SCREW 437X8	
22	158836009	1	メンイタ	FACE PLATE	
23	158837000	1	メンイタハ"ツキン	FACE PLATE PACKING	
24	062711412	4	ナヘ"コ476-32X14	SCREW 476X14	
25	159150009	1	カマシ"クメクラセン	OIL CAP	
26	158838009	1	ウフフタ	TOP COVER	
27	158839000	1	ウフフタハ"ツキン	TOP COVER PACKING	
28	062711412	8	ナヘ"コ476-32X14	SCREW 476X14	
29	158840109	1	ソクメンカハ"ーR	FRAME SIDE COVER (R)	
30	158841000	1	ソクメンカハ"ーRハ"ツキン	FRAME SIDE COVER (R) PACKING	
31	062711412	6	ナヘ"コ476-32X14	SCREW 476X14	
32	158842001	1	チヨウセツマ"フタ	ADJUST WINDOW COVER	
33	158843001	1	チヨウセツマ"フタウラ	ADJUST WINDOW INSIDE COVER	
34	081003670	1	O"リング"PW3	O RING PW3	
35	150756009	1	メクラセン	OIL CAP	
36	062670612	1	ナヘ"コ357-40X6	SCREW 357X6	
37	158844001	1	ワンザ"カ"ネ	WASHER	
38	158845009	1	ソクメンカハ"ーF	FRAME SIDE COVER (F)	
39	062710812	1	ナヘ"コ476-32X8	SCREW 476X8	
40	158847001	1	キ"ヤケースフタ	GEAR CASE COVER	
41	107321003	1	タ"ンネシ"4.76	STUD SCREW 4.76	
42	107017002	1	ナミハ"ネサ"カ"ネ	SPRING WASHER	
43	158849009	1	カムカハ"ー	CAM COVER	
44	062711412	3	ナヘ"コ476-32X14	SCREW 476X14	
45	158851101	1	オクリチヨウセツマ"フタ	FEED ADJUST WINDOW COVER	
46	107321003	1	タ"ンネシ"4.76	STUD SCREW 4.76	
47	107017002	1	ナミハ"ネサ"カ"ネ	SPRING WASHER	
48	158852009	1	デンヒ"ンカハ"ー	THREAD TAKE-UP COVER	
49	062680612	1	ナヘ"コ437-40X6	SCREW 437X6	
50	104449009	2	メクラセン	OIL CAP	
51	104450109	4	メクラセン	OIL CAP	
52	117934009	1	メクラセン	OIL CAP	
53	158882009	1	メクラセン	OIL CAP	
61	158899009	1	ヘ"ルトカハ"ーL	BELT COVER (L)	
62	159594009	1	ヘ"ルトカハ"ーSクミ	BELT COVER (S) ASSEMBLY	
62-1	158866009	1	ヘ"ルトカハ"ーS	BELT COVER (S)	
62-2	158867001	1	ヘ"ルトカハ"ーヒンジ"	BELT COVER HINGE	
62-3	158868001	1	ヒンジ"シ"ク	BELT COVER HINGE SHAFT	
63	062680812	2	ナヘ"コ437-40X8	SCREW 437X8	
64	158864001	1	ヘ"ルトカハ"ーストツハ"A	BELT COVER STOPPER (A)	
65	158865001	3	ストツハ"ウラカ"ネ	WASHER	
66	062680812	4	ナヘ"コ437-40X8	SCREW 437X8	
67	158869001	1	カハ"ーSストツハ"ハ"ネ	SPRING	
68	062680812	1	ナヘ"コ437-40X8	SCREW 437X8	
69	021680202	1	ナツト2シユ4.37	NUT 4.37	
70	158870009	1	ヘ"ルトカハ"ータイ	BELT COVER BASE	
71	143787001	1	ミゾ"ツキヒ"ン	DOWEL PIN	
72	158875001	2	シト"ウレハ"ーストツハ"ー	STARTING LEVER STOPPER	
73	159928009	1	メクラセン	OIL CAP	
82	159595000	1	カマウチカハ"ー	INSIDE COVER	
83	062681012	1	ナヘ"コ437-40X10	SCREW 437X10	

A. 主体関係 / Machine body / Maschinengehäuse /
 Corps de la machine / Cuerpo de la máquina

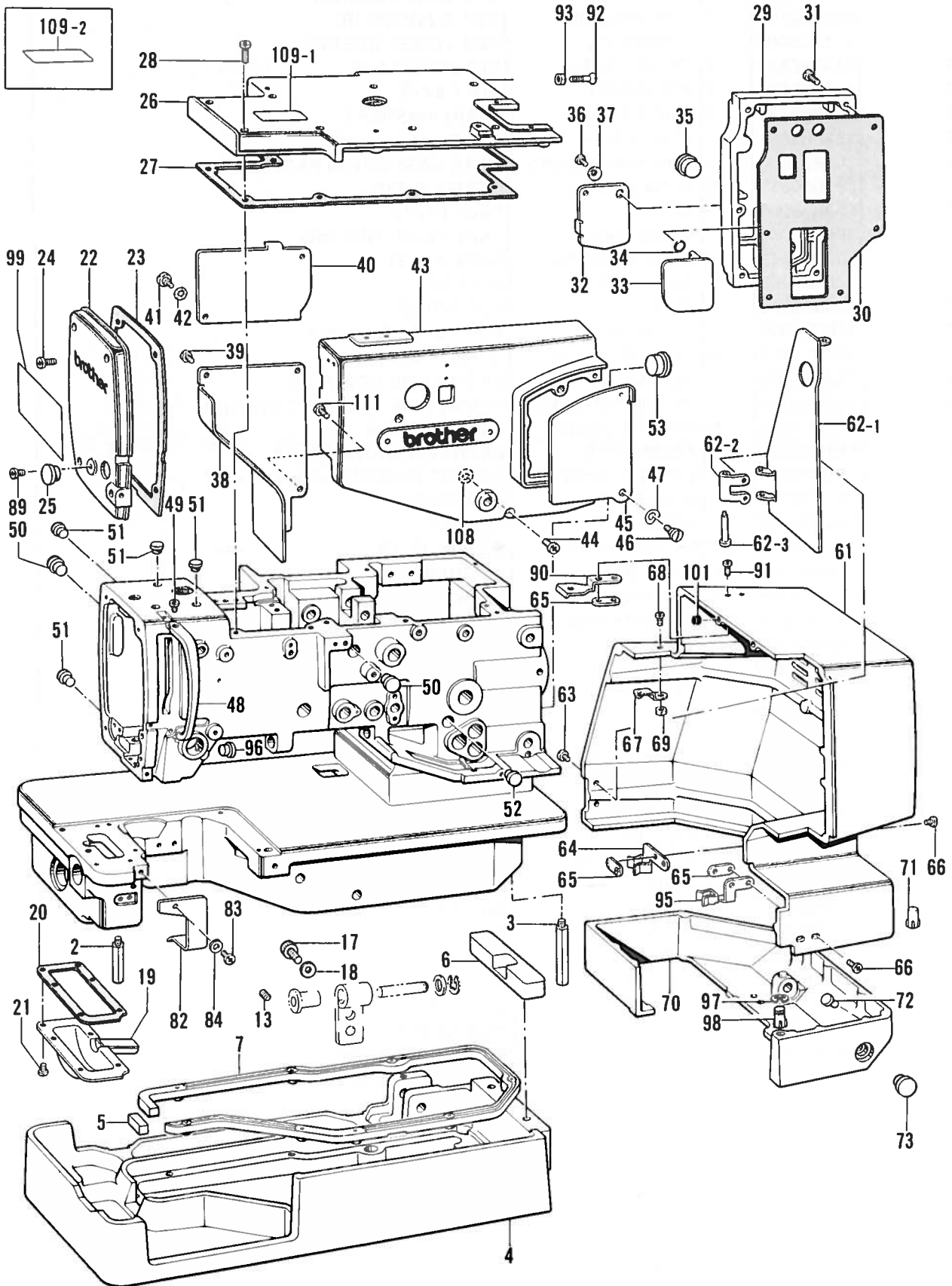

A. 主体関係 / Machine body / Maschinengehäuse /
Corps de la machine / Cuerpo de la máquina

REF NO.	CODE	Q'TY	ヒンメイ	NAME OF PARTS	RMKS
84	025680232	1	ヒラサ"カ"ネチユウ4.37	PLAIN WASHER 4.37	
89	062710812	2	ナヘ"コ476-32X8	SCREW 476X8	
90	158980001	1	ヘルトカハ"イタハ"ネ	PLATE SPRING	
91	062681212	2	ナヘ"コ437-40X12	SCREW 437X12	
92	141248001	1	ヘルトカハ"ハ"ネウケ	SPRING HOLDER	
93	105234003	1	ナツト4.37	NUT 4.37	
95	158969001	1	ヘルトカハ"ストツハ"°B	BELT COVER STOPPER (B)	
96	159928009	1	メクラセン	OIL CAP	
97	048070342	1	トメフE7	STOP RING E7	
98	159989001	1	ミゾ"ツキヒンBR8X22	DOWEL PIN 8X22	
99	S01009101	1	イトトオシセツメイイタ	THREADING DIAGRAM	
101	154578000	1	レハ"ストツハ"°	THREAD TRIMMER LEVER STOPPER	
108	142711001	3	ファイハ"ワツシヤ	WASHER	
109-1	S00875001	1	ステツカー	-----	
109-2	S01224000	1	-----	LABEL	
111	062711012	2	ナヘ"コ476-32X10	SCREW 476X10	

B. 針棒関係 / Needle bar mechanism / Nadelstangenvorrichtung /
 Mécanisme de la barre à aiguille / Mecanismo de la barra de aguja

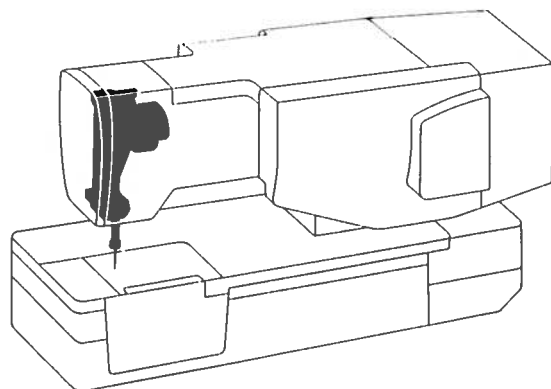
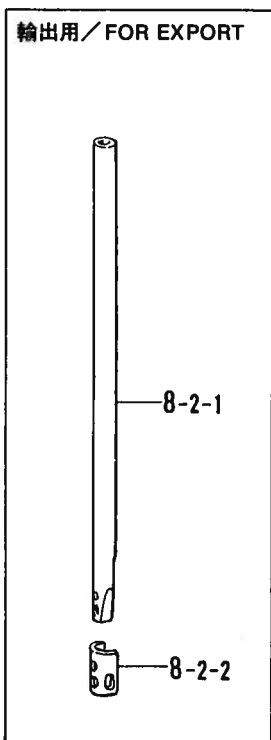
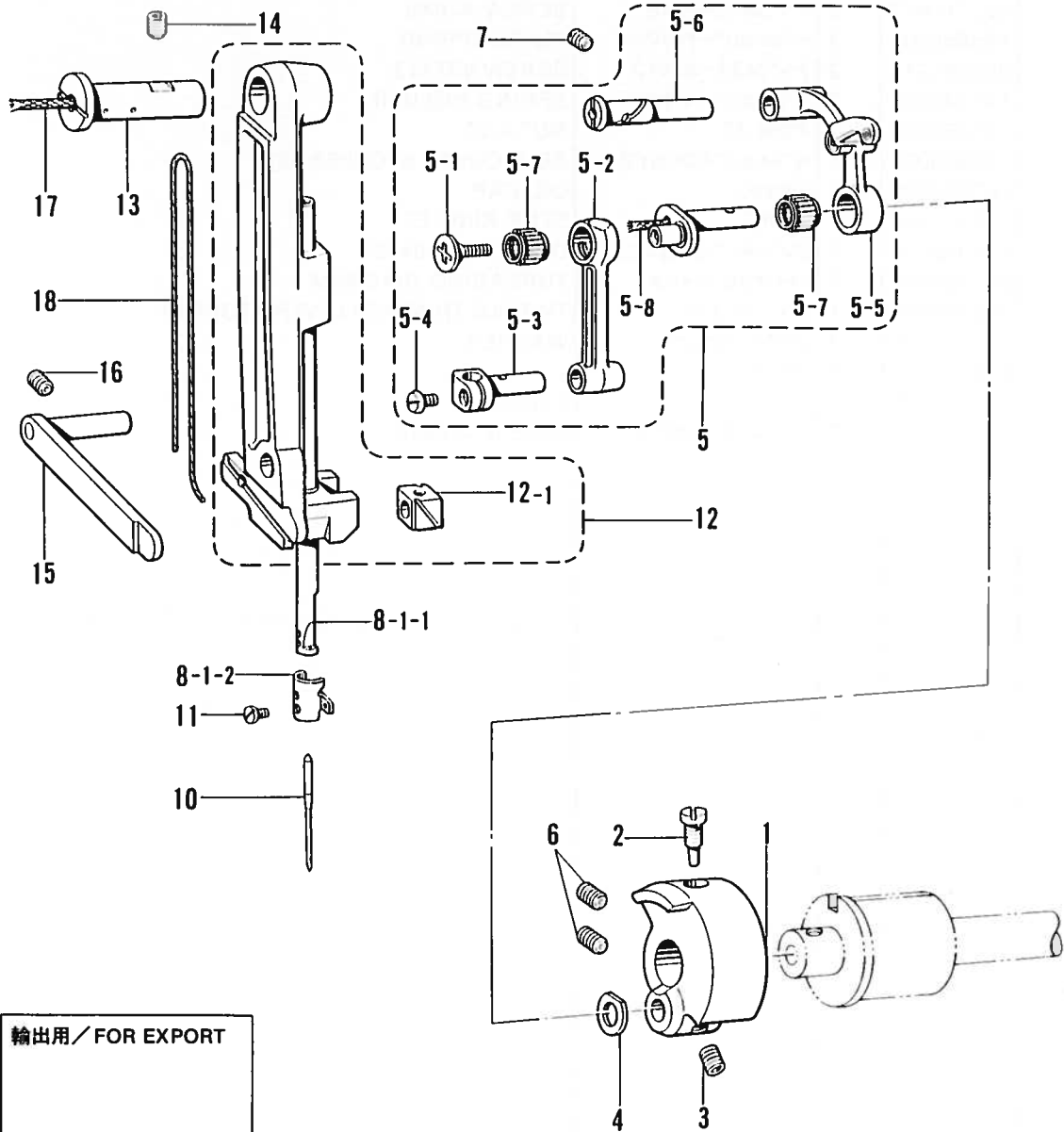

B. 針棒関係/Needle bar mechanism/Nadelstangenvorrichtung/
 Mécanisme de la barre à aiguille/Mecanismo de la barra de aguja

REF.NO.	CODE	Q'TY	ヒンメイ	NAME OF PARTS	RMKS
1	158880000	1	テンビ"ンクランクA	THREAD TAKE-UP CRANK (A)	
2	100250001	1	シメネジ"7.14	SCREW 7.14	
3	014770622	1	アナトメネジ"6.35クホ"ミ	SET SCREW 6.35	
4	110367001	1	サ"カ"ネ	WASHER	
5	159409101	1	ハリホ"ウレンカンクミ	THREAD TAKE-UP LEVER ASSEMBLY	
5-1	145465001	1	シメネジ"3.57L	SCREW 3.57 (L)	
5-2	S01143001	1	ハリホ"ウクランクロツト"	NEEDLE BAR CRANK ROD	
5-3	111237001	1	ハリホ"ウタ"キ	NEEDLE BAR CLAMP	
5-4	140004001	1	シメネジ"3.57	SCREW 3.57	
5-5	183216101	1	テンビ"ンタイササエクミ	THREAD TAKE-UP SUPPORT ASSEMBLY	
5-6	111468001	1	テンビ"ンササエシ"ク	THREAD TAKE-UP LEVER SUPPORT STUD	
5-7	116735000	2	ニート"ルヘ"アリング"	NEEDLE BEARING	
5-8	140430001	1	クミヒモ(L=40)	WICK (L=40)	
6	014770622	2	アナトメネジ"6.35クホ"ミ	SET SCREW 6.35	
7	014760622	1	アナトメネジ"5.95	SET SCREW 5.95	
8-1	158884201	1	ハリホ"ウクミ	-----	
8-1-1	158885201	1	ハリホ"ウ	-----	
8-1-2	159916001	1	ハリホ"ウイトアンナイ	-----	
8-2	S11473101	1	-----	NEEDLE BAR (B) ASSEMBLY	
8-2-1	S11474101	1	-----	NEEDLE BAR (B)	
8-2-2	148053001	1	-----	NEEDLE BAR THREAD GUIDE	
10	S13594080	1	ミシンハリ1906#12	-----	
10	S13594090	1	-----	NEEDLE 1906 #14	
11	140553102	1	アタマツキトメネジ"3.18	SET SCREW 3.18	
12	158886101	1	ハリホ"ウタ"イクミ	NEEDLE BAR SUPPORT ASSEMBLY	
12-1	159624001	1	ハリホ"ウタ"イカクコマ	NEEDLE BAR BRACKET SLIDE BLOCK	
13	158888001	1	ハリホ"ウタ"イササエシ"ク	NEEDLE BAR BRACKET SUPPORT STUD	
14	014760622	1	アナトメネジ"5.95	SET SCREW 5.95	
15	158889001	1	ハリホ"ウタ"イアンナイ	NEEDLE BAR BRACKET GUIDE	
16	014760622	1	アナトメネジ"5.95	SET SCREW 5.95	
17	159572000	1	クミヒモ	WICK	
18	159561001	1	リリアンクミヒモ	WICK	

C. 上軸関係 / Upper shaft mechanism / Obere Welle /
 Mécanisme de l'arbre supérieur / Mecanismo del eje superior

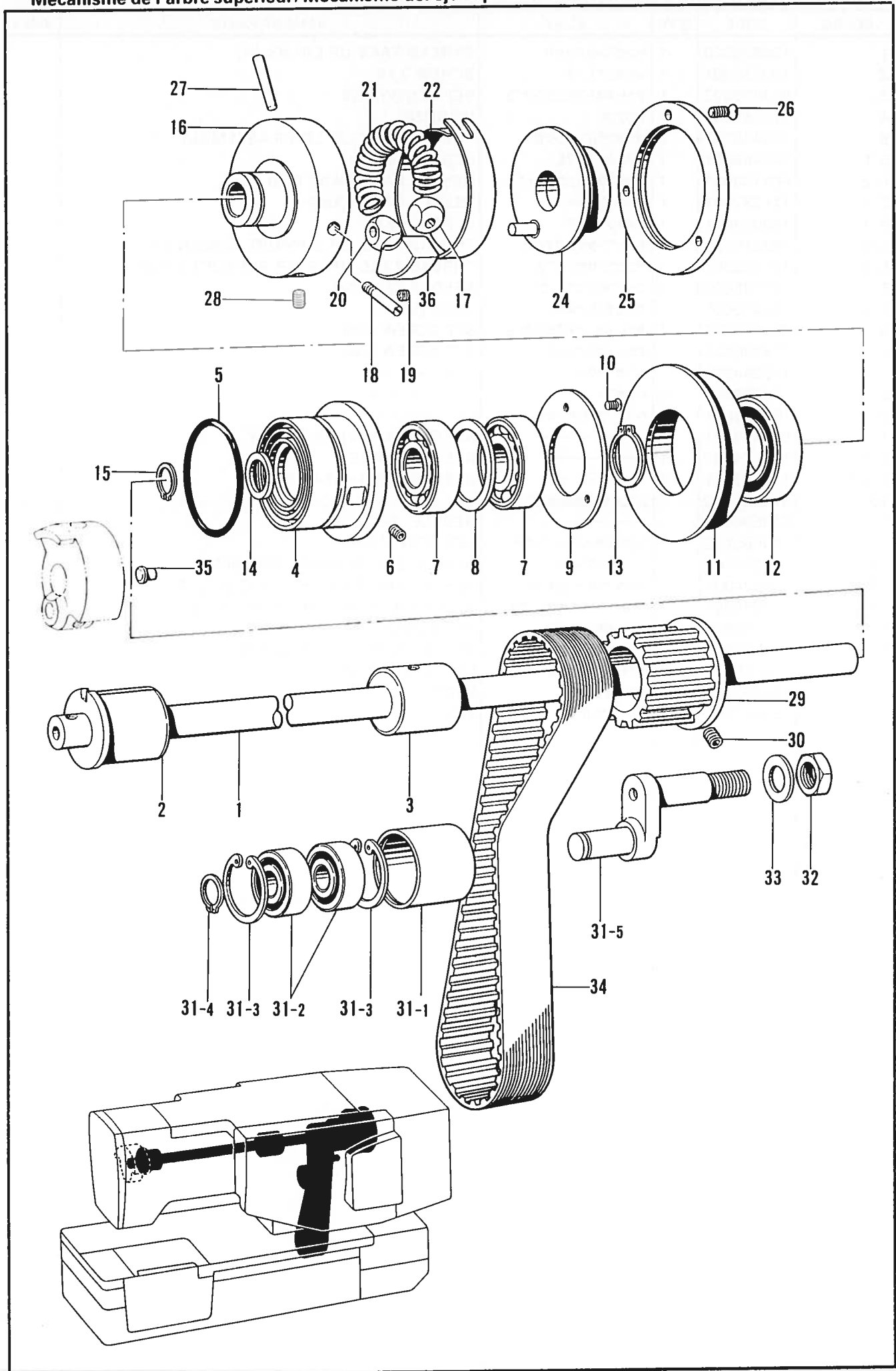

C. 上軸関係 / Upper shaft mechanism / Obere Welle /
 Mécanisme de l'arbre supérieur / Mecanismo del eje superior

REF.NO.	CODE	Q'TY	ヒンメイ	NAME OF PARTS	RMKS
1	158891001	1	ウワジ"ク	UPPER SHAFT	
2	158892001	1	ウワジ"クメタルF	UPPER SHAFT BUSH (F)	
3	158893000	1	ウワジ"クメタルM	UPPER SHAFT BUSH (M)	
4	158894000	1	ハ"アリング"ケース	BEARING CASE	
5	081048070	1	Oリング"P48	O RING P48	
6	014760622	1	アナトメネシ"5.95	SET SCREW 5.95	
7	072630260	2	ハ"アリング"6302VV	BEARING 6302VV	
8	158895001	1	ハ"アリング"カンザ"	BEARING COLLAR	
9	158896001	1	ハ"アリング"フタ	BEARING CAP	
10	102843004	3	サラネシ"3.57	SCREW 3.57	
11	158897001	1	Pプーリー	IDLE PULLEY	
12	072600560	1	タマシ"クウケ6005VV	BALL BEARING 6005VV	
13	048250142	1	トメワジ"クヨウC25	STOP RING C25	
14	116920001	1	オクリシ"クスラストリング"	THRUST RING	
15	048150142	1	トメワジ"クヨウC15	STOP RING C15	
16	158898001	1	ウワジ"クプーリ	UPPER SHAFT PULLEY	
17	159427001	1	ウワジ"クプーリカクコマ	UPPER SHAFT PULLEY SLIDE BLOCK	
18	159424001	1	プーリカクコマシ"ク	PULLY SHAFT	
19	014679320	1	アナトメネシ"3.57クホ"ミ	SET SCREW 3.57	
20	158941001	1	ストツフ"カムカクコマ	PULLEY STOP CAM SLIDE BLOCK	
21	159425001	1	プーリカンシヨウハ"ネ	SPRING	
22	159420001	1	プーリハ"ネカハ"ー	SPRING COVER	
24	158901101	1	ストツフ"カムクミ	STOP CAM ASSEMBLY	
25	158904001	1	ストツフ"カムフタ	STOP CAM CAP	
26	117348001	3	サラネシ"3.57	SCREW 3.57	
27	S01319001	1	テーハ"ピン4X28	TAPER PIN 4X28	
28	014770622	1	アナトメネシ"6.35クホ"ミ	SET SCREW 6.35	
29	159744100	1	Uタイミング"プーリクミ	UPPER TIMING PULLEY ASSEMBLY	
30	014760622	4	アナトメネシ"5.95	SET SCREW 5.95	
31	158906001	1	アイト"ラープーリクミ	IDLER PULLEY ASSEMBLY	
31-1	158907001	1	アイト"ラープーリ	IDLER PULLEY	
31-2	072620260	2	タマシ"クウケ6202VVC2	BALL BEARING 6202VVC2	
31-3	048350242	2	トメワアナヨウC35	STOP RING C35	
31-4	048150142	1	トメワジ"クヨウC15	STOP RING C15	
31-5	158908001	1	アイト"ラープーリウデ"	IDLER PULLEY ARM	
32	158909001	1	ナツト12.7ヒタ"リ	NUT 12.7 (LEFT)	
33	025900232	1	ヒラサ"ガ"ネチユウ12.70	PLAIN WASHER 12.70	
34	158910000	1	タイミング"ヘルト	TIMING BELT	
35	111865001	1	オイルメクラセン	OIL CAP	
36	S00862000	1	ストツフ"カムササエ	STOP CAM SUPPORT	

D. 針振関係 / Zigzag mechanism / Zickzackvorrichtung /
 Mécanisme du zigzag / Mecanismo del zigzag

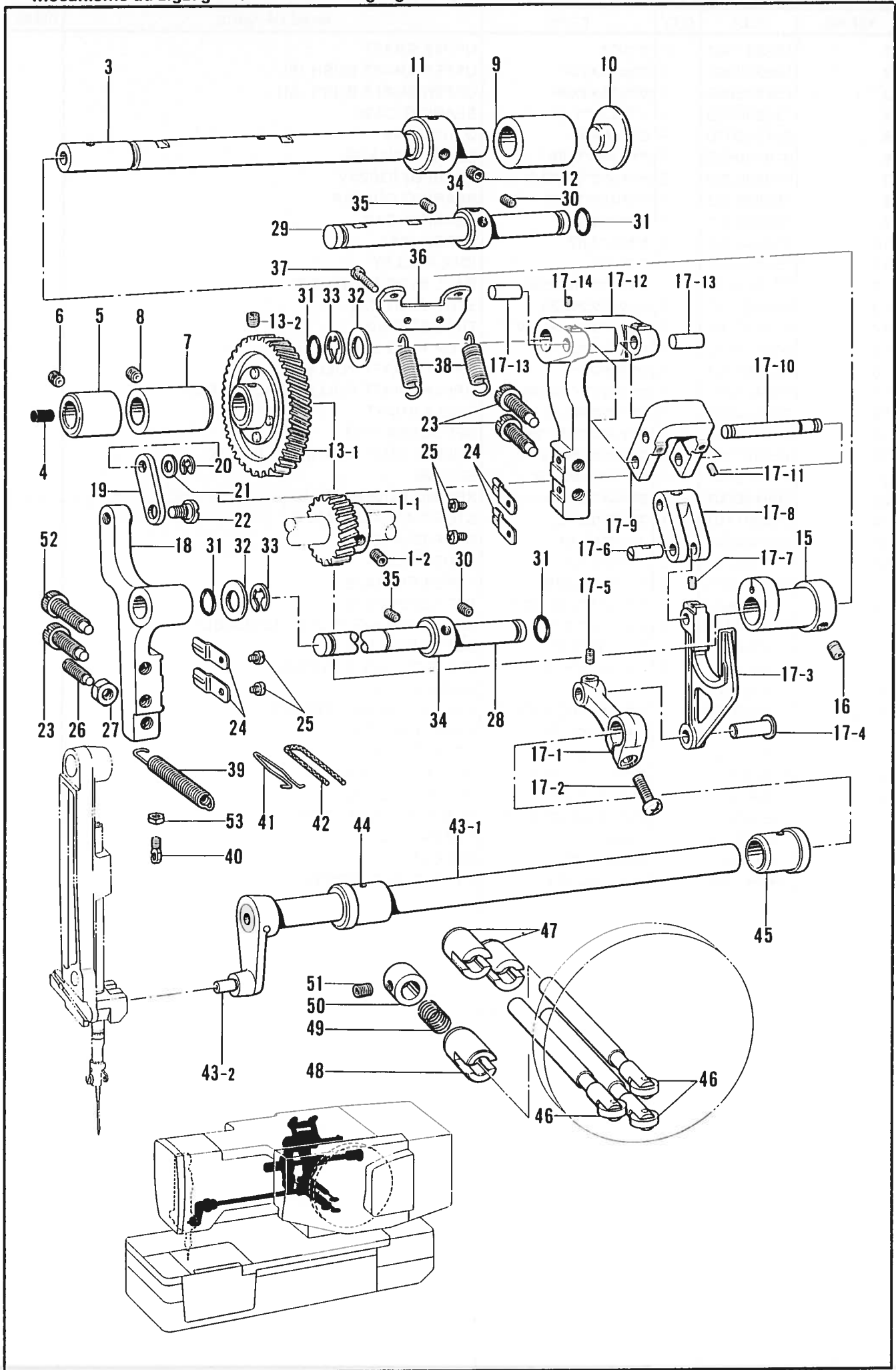

D. 針振関係 / Zigzag mechanism / Zickzackvorrichtung /
Mécanisme du zigzag / Mecanismo del zigzag

REF. NO.	CODE	Q'TY	ヒンメイ	NAME OF PARTS	RMKS
1	183702001	1	ケ"ンソクキ"ヤクミ	SPPED REDUCTION GEAR ASSEMBLY	
1-1	141309001	1	ケ"ンソクキ"ヤ	SPEED REDUCTION GEAR	
1-2	014770622	2	アナトメネシ"6.35クホ"ミ	SET SCREW 6.35	
3	158911001	1	フクシ"ク	SUB SHAFT	
4	156641001	2	メクラセン	OIL CAP	
5	158913001	1	フクシ"ク"メタルF	SUB SHAFT BUSH (F)	
6	014760622	1	アナトメネシ"5.95	SET SCREW 5.95	
7	158914001	1	フクシ"ク"メタルM	SUB SHAFT BUSH (M)	
8	014760622	1	アナトメネシ"5.95	SET SCREW 5.95	
9	158915001	1	フクシ"ク"メタルR	SUB SHAFT BUSH (R)	
10	158916009	1	メクラセン	OIL CAP	
11	101486001	1	セツトカラー	SET COLLAR	
12	014760622	2	アナトメネシ"5.95	SET SCREW 5.95	
13	183707001	1	フクシ"ク"キ"ヤクミ	SUB SHAFT GEAR ASSEMBLY	
13-1	158917001	1	フクシ"ク"キ"ヤクミ	SUB SHAFT GEAR ASSEMBLY	
13-2	014770622	2	アナトメネシ"6.35クホ"ミ	SET SCREW 6.35	
15	158919101	1	ハリフリカム	ZIG ZAG CAM	
16	014770622	2	アナトメネシ"6.35クホ"ミ	SET SCREW 6.35	
17	159547001	1	ハリフリキクミ	ZIGZAG ADJUST CAM ASSEMBLY	
17-1	158947001	1	ハリフリレハ"ーR	ZIGZAG ADJUST LEVER (R)	
17-2	S01304001	1	シメネシ"6.35X18	SCREW 6.35X18	
17-3	158920001	1	ハリフリフタマタ	ZIGZAG ADJUST FORK	
17-4	158921001	1	ハリフリフタマタシ"ク	ZIGZAG ADJUST FORK STUD	
17-5	014770622	1	アナトメネシ"6.35クホ"ミ	SET SCREW 6.35	
17-6	158922001	1	フタマタリンクピン	PIN	
17-7	014680622	1	アナトメネシ"4.37クホ"ミ	SET SCREW 4.37	
17-8	158923001	1	ハリフリリンク	ZIGZAG ADJUST LINK	
17-9	158924001	1	キシ"ユニイチヘンカンリンク	LINK	
17-10	158925001	1	ハリフリキシ"ユニシ"ク	ZIGZAG ADJUST SHAFT	
17-11	014680622	2	アナトメネシ"4.37クホ"ミ	SET SCREW 4.37	
17-12	158928000	1	キシ"ユニイチチヨウセツウテ"	ADJUST ARM	
17-13	158927001	2	ヘンカンリンクシテンシ"ク	FULCRUM SHAFT	
17-14	014680622	2	アナトメネシ"4.37クホ"ミ	SET SCREW 4.37	
18	158932000	1	ハリフリチヨウセツウテ"	ZIGZAG ADJUST ARM	
19	158926001	1	フリハハ"ヘンカンリンク	ZIGZAG ADJUST LINK	
20	048050342	1	トメワE5	STOP RING E5	
21	153138001	1	サ"カ"ネ	WASHER	
22	145480001	1	タ"ンネシ"6.35	STUD SCREW 6.35	
23	158930001	3	ハリフリチヨウセツネシ"	ADJUST SCREW	
24	158931001	4	ハリフリチヨウセツネシ"オサエ	ADJUST SCREW PRESSER	
25	062680512	4	ナヘ"コ437-40X5	SCREW 437X5	
26	159905001	1	トメヌイチヨウセツネシ"	ADJUST SCREW	
27	105812003	1	ナツト7.94	NUT 7.94	
28	158929001	1	チヨウセツウテ"シ"クA	ADJUST ARM SHAFT (A)	
29	158933001	1	チヨウセツウテ"シ"クB	ADJUST ARM SHAFT (B)	
30	014760622	2	アナトメネシ"5.95	SET SCREW 5.95	
31	110558001	4	Oリング"	O RING	
32	115007001	2	サ"カ"ネ	WASHER	
33	146293001	2	トメワE10	STOP RING E10	
34	117671002	2	セツトカラー	SET COLLAR	
35	014770622	4	アナトメネシ"6.35クホ"ミ	SET SCREW 6.35	
36	159426001	1	ハリフリハ"ネカケ	SPRING HOOK	
37	062681612	2	ナヘ"コ437-40X16	SCREW 437X16	
38	158935001	2	ハリフリハ"ネA	SPRING (A)	
39	158939001	1	ハリフリハ"ネB	SPRING (B)	
40	141334001	1	ハ"ネカケ	SPRING HOOK	
41	158940001	1	ハ"ネカケ	SPRING HOOK	
42	159562000	1	クミヒモ	WICK	
43	158942001	1	ハリフリレハ"ーFクミ	ZIGZAG LEVER (F) ASSEMBLY	
43-1	158944001	1	ハリフリレハ"ーシ"ク	ZIGZAG LEVER SHAFT	
43-2	159625001	1	レハ"ーFカクコマシ"ク	ZIGZAG LEVER (F) STUD	
44	158945001	1	ハリフリシ"ク"メタルF	ZIGZAG LEVER SHAFT BUSH (F)	

D. 針振關係 / Zigzag mechanism / Zickzackvorrichtung /
 Mécanisme du zigzag / Mecanismo del zigzag

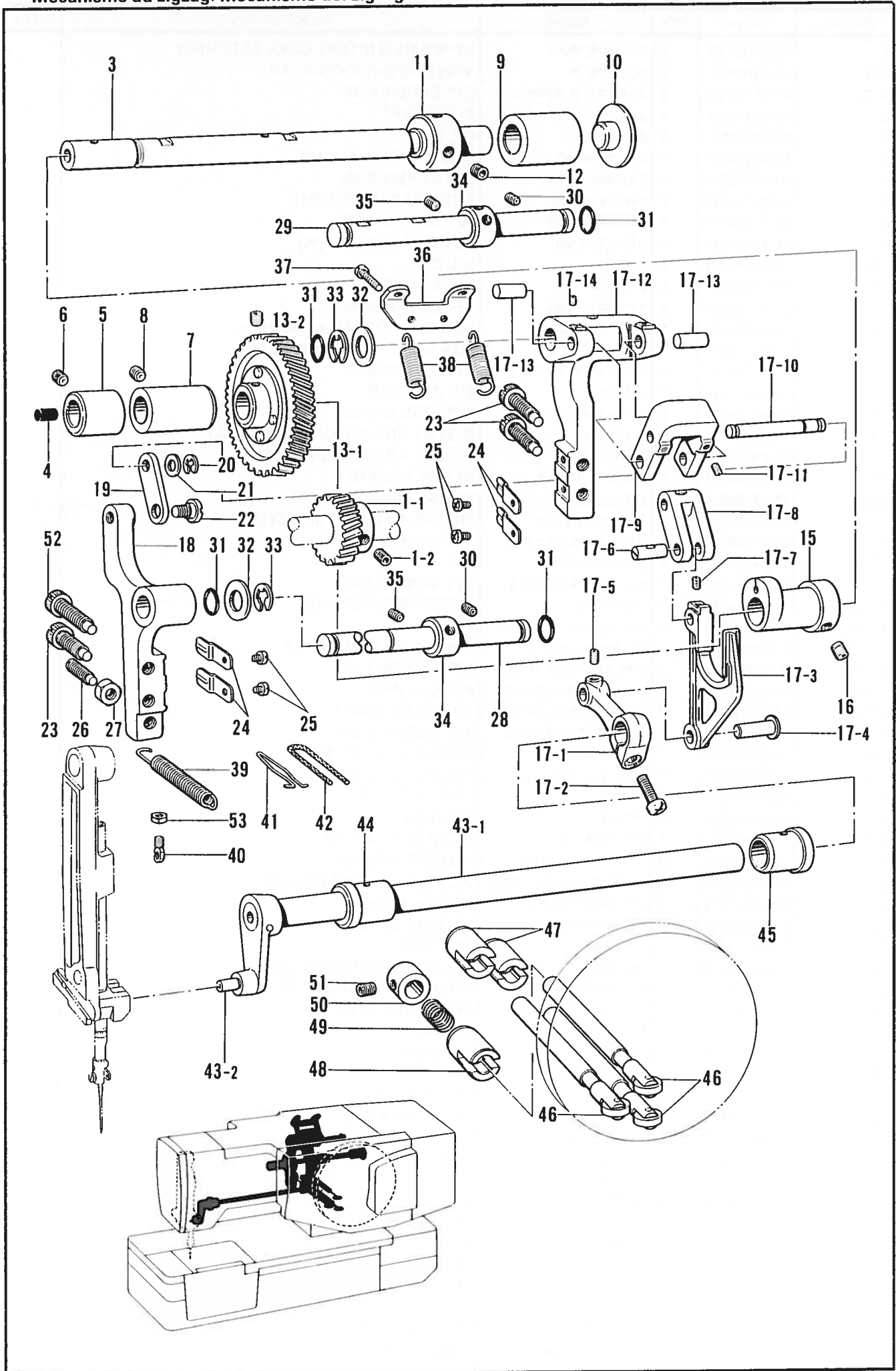

D. 針振関係 / Zigzag mechanism / Zickzackvorrichtung /
 Mécanisme du zigzag / Mecanismo del zigzag

REF NO.	CODE	Q'TY	ヒンメイ	NAME OF PARTS	RMKS
45	158946001	1	ハリフリジ"クメタルR	ZIGZAG LEVER SHAFT BUSH (R)	
46	158948001	3	ハリフリオシホ"ウクミ	ZIGZAG CONNECTING SHAFT ASSEMBLY	
47	158950000	2	ハリフリオシホ"ウメタル	ZIGZAG ADJUST BAR BUSH	
48	158951000	1	カントメオシホ"ウメタル	BAR TACK ADJUST BAR BUSH	
49	158952001	1	カントメオシホ"ウハ"ネ	SPRING	
50	141351001	1	セツトカラー	SET COLLAR	
51	014770622	1	アナトメネジ"6.35クボ"ミ	SET SCREW 6.35	
52	159906001	1	カント"メチヨウセツネジ"	ADJUST SCREW	
53	100022005	1	ナツト5.95	NUT 5.95	

E. 停止關係 / Clutch mechanism / Kupplungsvorrichtung /
 Mécanisme de l'embrayage / Mecanismo del embrague

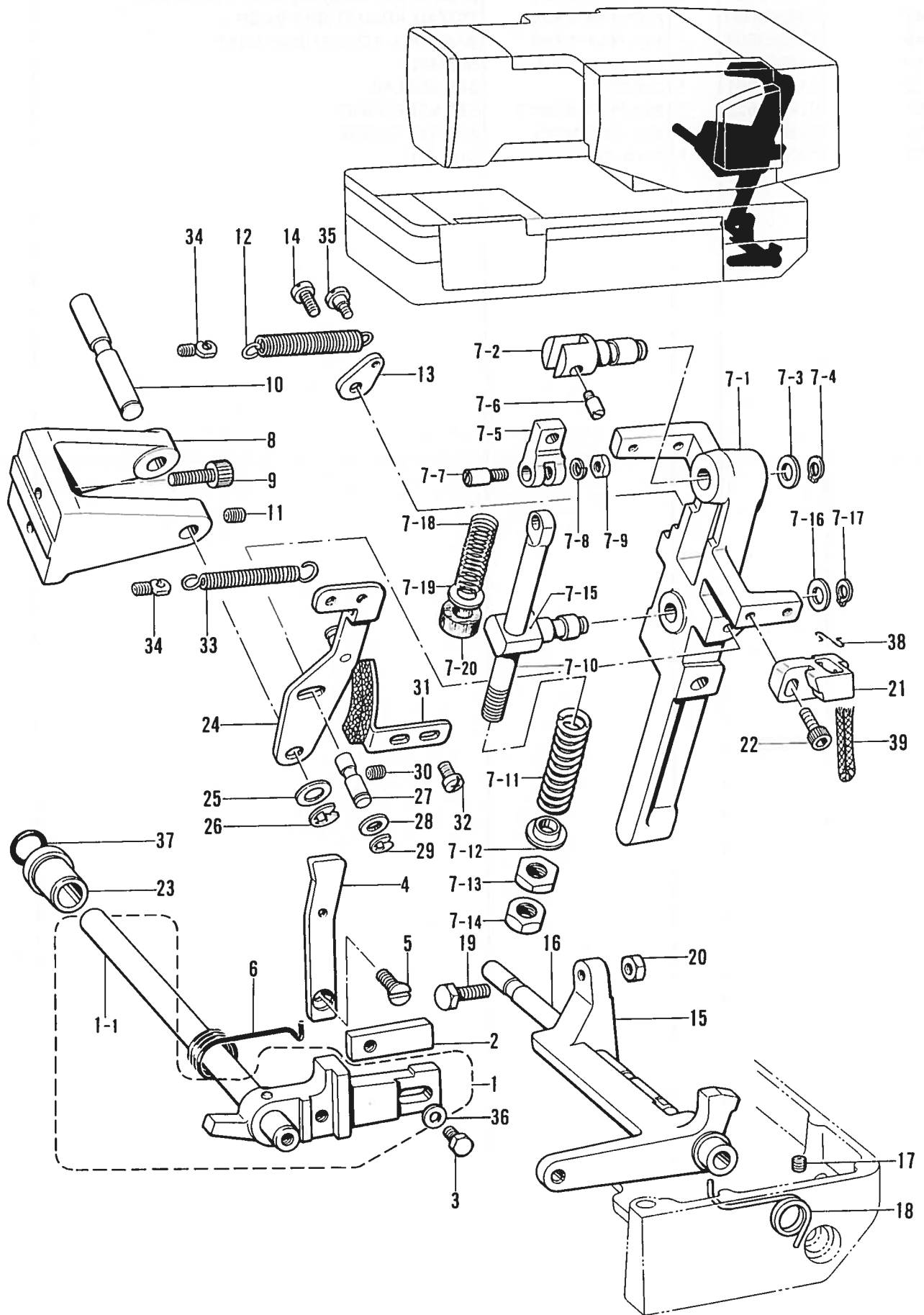

E. 停止関係 / Clutch mechanism / Kupplungsvorrichtung /
Mécanisme de l'embrayage / Mecanismo del embrague

REF. NO.	CODE	Q'TY	ヒンメイ	NAME OF PARTS	RMKS
1	158953001	1	テイシレハークミ	STOP LEVER ASSEMBLY	
1-1	158955001	1	テイシレハークシク	STOP LEVER SHAFT	
2	158956001	1	テイシレハークツメ	STOP LEVER CLAW	
3	017771412	1	ボルト6.35X14	BOLT 6.35X14	
4	158957001	1	テイシカムセツシヨクシ	STOP CAM PLATE	
5	S01698001	1	サラネシ"5.95X12	SCREW 5.95X12	
6	158958101	1	テイシレハークハネ	SPRING	
7	159548101	1	クラツチレハークミ	CLUTCH LEVER ASSEMBLY	
7-1	158960001	1	クラツチレハーク	CLUTCH LEVER	
7-2	142667101	1	クラツチストツハササエ	CLUTCH STOPPER SUPPORT	
7-3	025100132	1	ヒラサ"ガ"ネシヨウ10	PLAIN WASHER 10	
7-4	048100142	1	トメワシ"クヨウC10	STOP RING C10	
7-5	115545001	1	クラツチストツハ	CLUTCH STOPPER	
7-6	115544001	1	クラツチストツハササエシク	CLUTCH STOPPER SUPPORT SHAFT	
7-7	115546001	1	クラツチストツハシク	CLUTCH STOPPER STUD	
7-8	028050240	1	ハ"ネサ"ガ"ネ2-5	SPRING WASHER 2-5	
7-9	021710202	1	ナツト2シユ4.76	NUT 4.76	
7-10	158962001	1	ストツハ"ハ"ネシク	SPRING SHAFT	
7-11	158963001	1	ストツハ"オシハ"ネ	SPRING	
7-12	158964001	1	ストツハ"ハ"ネカラー	SPRING COLLAR	
7-13	021860312	1	ナツト3シユ9.52	NUT 9.52	
7-14	100075004	1	ナツト9.52	NUT 9.52	
7-15	158965001	1	チヨウセツハ"ネシ"クダ"キ	SHAFT CLAMP	
7-16	025100132	1	ヒラサ"ガ"ネシヨウ10	PLAIN WASHER 10	
7-17	048100142	1	トメワシ"クヨウC10	STOP RING C10	
7-18	115551001	1	ストツハ"オシハ"ネB	SPRING (B)	
7-19	025100132	1	ヒラサ"ガ"ネシヨウ10	PLAIN WASHER 10	
7-20	115550001	1	フェルト	FELT	
8	158959001	1	クラツチレハーク"イ	CLUTCH LEVER BRACKET	
9	018082022	2	アナボルト8X20	BOLT 8X20	
10	158961001	1	クラツチレハークシク	CLUTCH LEVER SHAFT	
11	014760622	2	アナトメネシ"5.95	SET SCREW 5.95	
12	S11309001	1	クラツチヒキハ"ネ	SPRING	
13	115558002	1	ハ"ネチヨウセツイタ	ADJUST PLATE	
14	062761212	1	ナヘ"コ595-28X12	SCREW 595X12	
15	158968001	1	シト"ウレハーク	STARTING LEVER	
16	158970001	1	シト"ウレハークシク	STARTING LEVER SHAFT	
17	014760622	1	アナトメネシ"5.95	SET SCREW 5.95	
18	158971001	1	シト"ウレハーク"モト"シハ"ネ	SPRING	
19	115585001	1	ボルト7.94	BOLT 7.94	
20	152997001	1	ナツト7.94	NUT 7.94	
21	S13727001	1	クラツチツメ	CLUTCH CLAW	
22	018061422	2	アナボルト6X14	BOLT 6X14	
23	158973001	1	テイシレハークシクメタル	STOP LEVER SHAFT BUSH	
24	158974101	1	ブレーキレハーク	BRAKE LEVER	
25	025100132	1	ヒラサ"ガ"ネシヨウ10	PLAIN WASHER 10	
26	048100142	1	トメワシ"クヨウC10	STOP RING C10	
27	158975001	1	ブレーキレハーク"ピン	PIN	
28	025080132	1	ヒラサ"ガ"ネシヨウ8	PLAIN WASHER 8	
29	048060342	1	トメワE6	STOP RING E6	
30	014760622	1	アナトメネシ"5.95	SET SCREW 5.95	
31	158976001	1	ブレーキシユウクミ	BRAKE SHOE ASSEMBLY	
32	062760812	2	ナヘ"コ595-28X8	SCREW 595X8	
33	158979001	1	ブレーキハ"ネ	BRAKE SPRING	
34	141334001	2	ハ"ネカク	SPRING HOOK	
35	115559002	1	タ"ンネシ"4.76	STUD SCREW 4.76	
36	025770232	1	ヒラサ"ガ"ネチユウ6.35	PLAIN WASHER 6.35	
37	081010670	1	Oリング"PW10	O RING PW10	
38	116795000	1	クリップ	CLIP	
39	117006001	1	クミヒモ(L=60)	WICK (L=60)	

F. ベルト寄せ関係 / Belt shift mechanism / Riemenumstellvorrichtung /
 Mécanisme du changement de courroie / Mecanismo de la transladación de correas

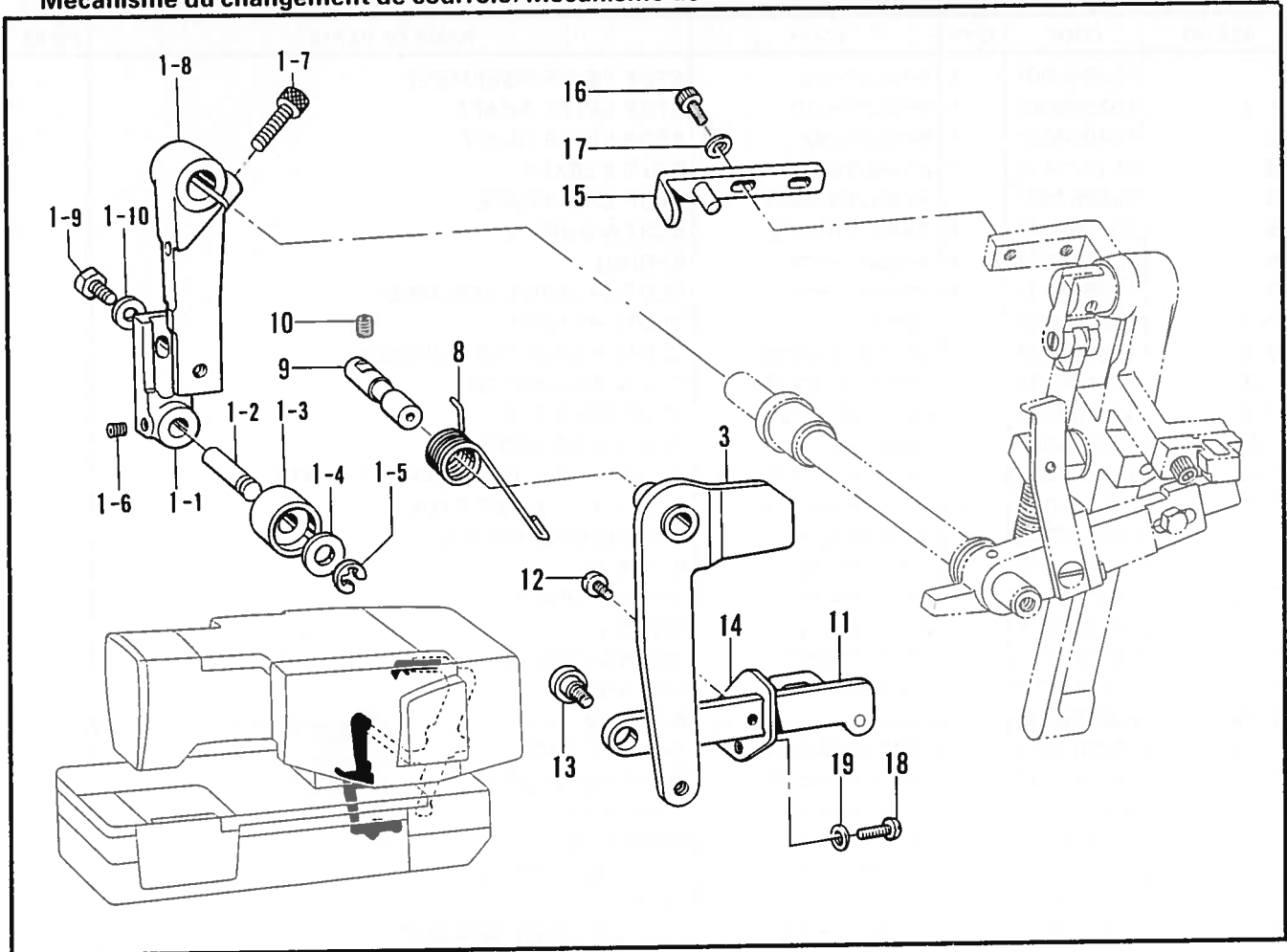

G. テンションプーリー関係 / Tension pulley mechanism / Spannrolle /
 Mécanisme de la poulie de tension / Mecanismo de la polea de tensión

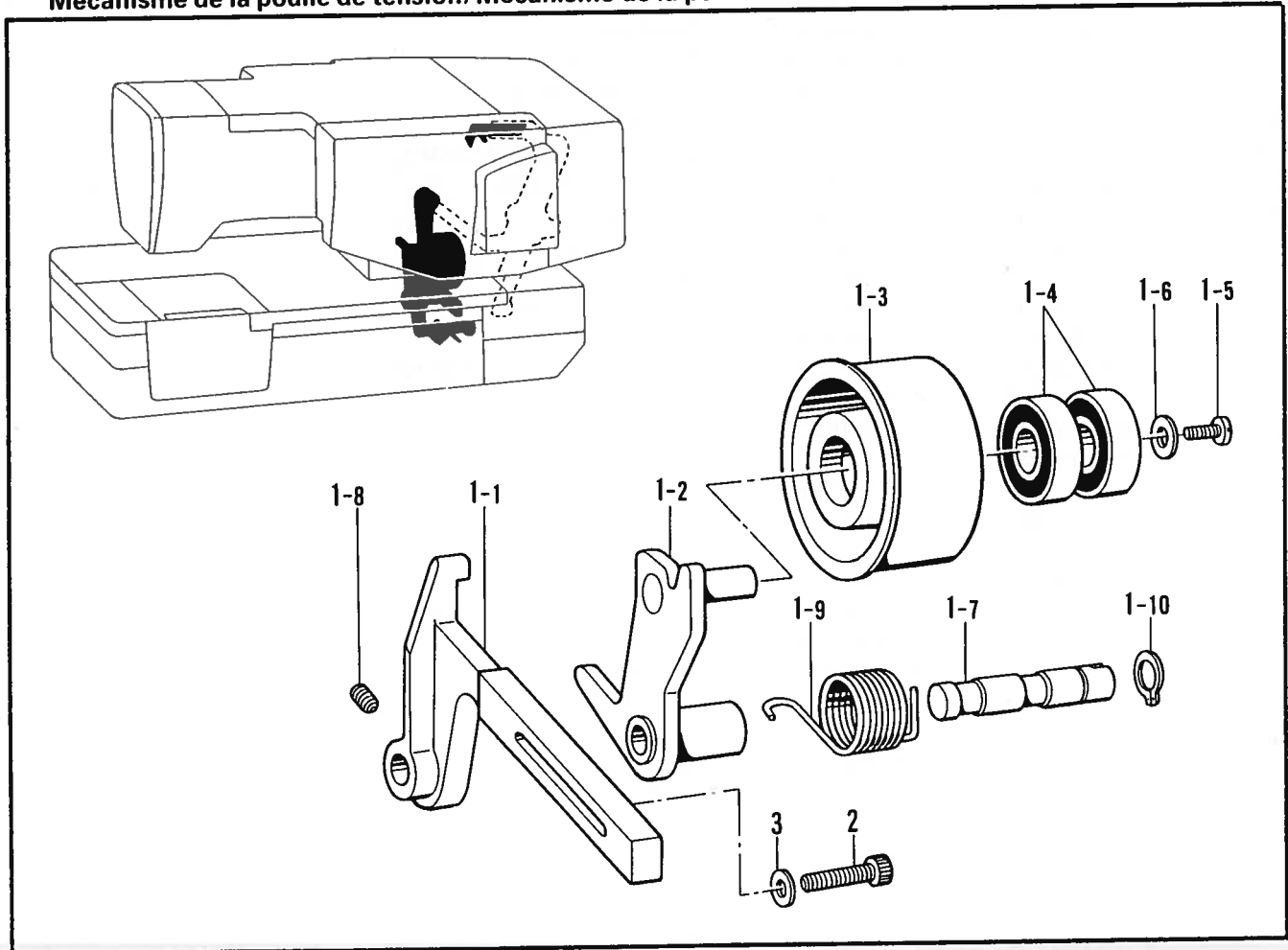

F. ベルト寄せ関係 / Belt shift mechanism / Riemenumstellvorrichtung /
 Mécanisme du changement de courroie / Mecanismo de la translación de correas

REF. NO.	CODE	Q'TY	ヒンメイ	NAME OF PARTS	RMKS
1	S19846001	1	ベルトヨセクト"ウレハ"クミ	BELT SHIFT LEVER ASSEMBLY	
1-1	S19806001	1	ベルトヨセクト"ウレハ"-B	BELT SHIFT LEVER (B)	
1-2	S19804001	1	ベルトヨセローラシク	BELT SHIFT ROLLER STUD	
1-3	S19805001	1	ベルトヨセローラ	BELT SHIFT ROLLER	
1-4	025080132	1	ヒラサ"カ"ネシヨウ8	PLAIN WASHER 8	
1-5	048060342	1	トメフE6	STOP RING E6	
1-6	014760622	1	アナトメネシ"5.95	SET SCREW 5.95	
1-7	018062222	1	アナホ"ルト6X22	BOLT 6X22	
1-8	S19807001	1	ベルトヨセクト"ウレハ"-A	BELT SHIFT LEVER (A)	
1-9	017761212	1	ホ"ルト5.95X12	BOLT 5.95X12	
1-10	025060232	1	ヒラサ"カ"ネチユウ 6	PLAIN WASHER 6	
3	S19808001	1	ベルトヨセレハ-	BELT SHIFT LEVER	
8	158995001	1	ベルトヨセレハ"-ハ"ネ	PLATE SPRING	
9	158996001	1	ベルトヨセレハ"-シ"ク	BELT SHIFT LEVER STUD	
10	014760622	1	アナトメネシ"5.95	SET SCREW 5.95	
11	158997001	1	ベルトヨセシタ	BELT SHIFT (LOWER)	
12	062710612	1	ナヘ"コ476-32X6	SCREW 476X6	
13	158998001	1	タ"ンネシ"6.35	STUD SCREW 6.35	
14	158999100	1	ベルトヨセシタアンナイ	BELT SHIFT GUIDE (LOWER)	
15	159000101	1	ベルトヨセU	BELT SHIFT (U)	
16	018061222	2	アナホ"ルト6X12	BOLT 6X12	
17	025060232	2	ヒラサ"カ"ネチユウ 6	PLAIN WASHER 6	
18	107407003	2	シメネシ"4.37	SCREW 4.37	
19	025680132	2	ヒラサ"カ"ネシヨウ4.37	PLAIN WASHER 4.37	

G. テンションプーリ関係 / Tension pulley mechanism / Spannrolle /
 Mécanisme de la poulie de tension / Mecanismo de la polea de tensión

REF. NO.	CODE	Q'TY	ヒンメイ	NAME OF PARTS	RMKS
1	159551101	1	テンションプーリクミ	TENSION PULLEY ASSEMBLY	
1-1	159007101	1	テンションプーリタイ	TENSION PULLEY BRACKET	
1-2	159008001	1	テンションプーリウテ"クミ	TENSION PULLEY ARM ASSEMBLY	
1-3	159011000	1	テンションプーリ	TENSION PULLEY	
1-4	072620160	2	タマシ"クウケ6201VV	BALL BEARING 6201VV	
1-5	062761212	1	ナヘ"コ595-28X12	SCREW 595X12	
1-6	025060332	1	ヒラサ"カ"ネタ"イ6	PLAIN WASHER 6	
1-7	159012001	1	テンションプーリウテ"シ"ク	TENSION PULLEY ARM SHAFT	
1-8	014760622	1	アナトメネシ"5.95	SET SCREW 5.95	
1-9	159013001	1	テンションプーリウテ"ハ"ネ	SPRING	
1-10	048100142	1	トメフシ"クヨウC10	STOP RING C10	
2	018082022	1	アナホ"ルト8X20	BOLT 8X20	
3	025080232	1	ヒラサ"カ"ネチユウ8	PLAIN WASHER 8	

H. 押工関係 / Presser foot mechanism / Stoffdruckerfuß /
 Mécanisme du pied presseur / Mecanismo de la prensatelas

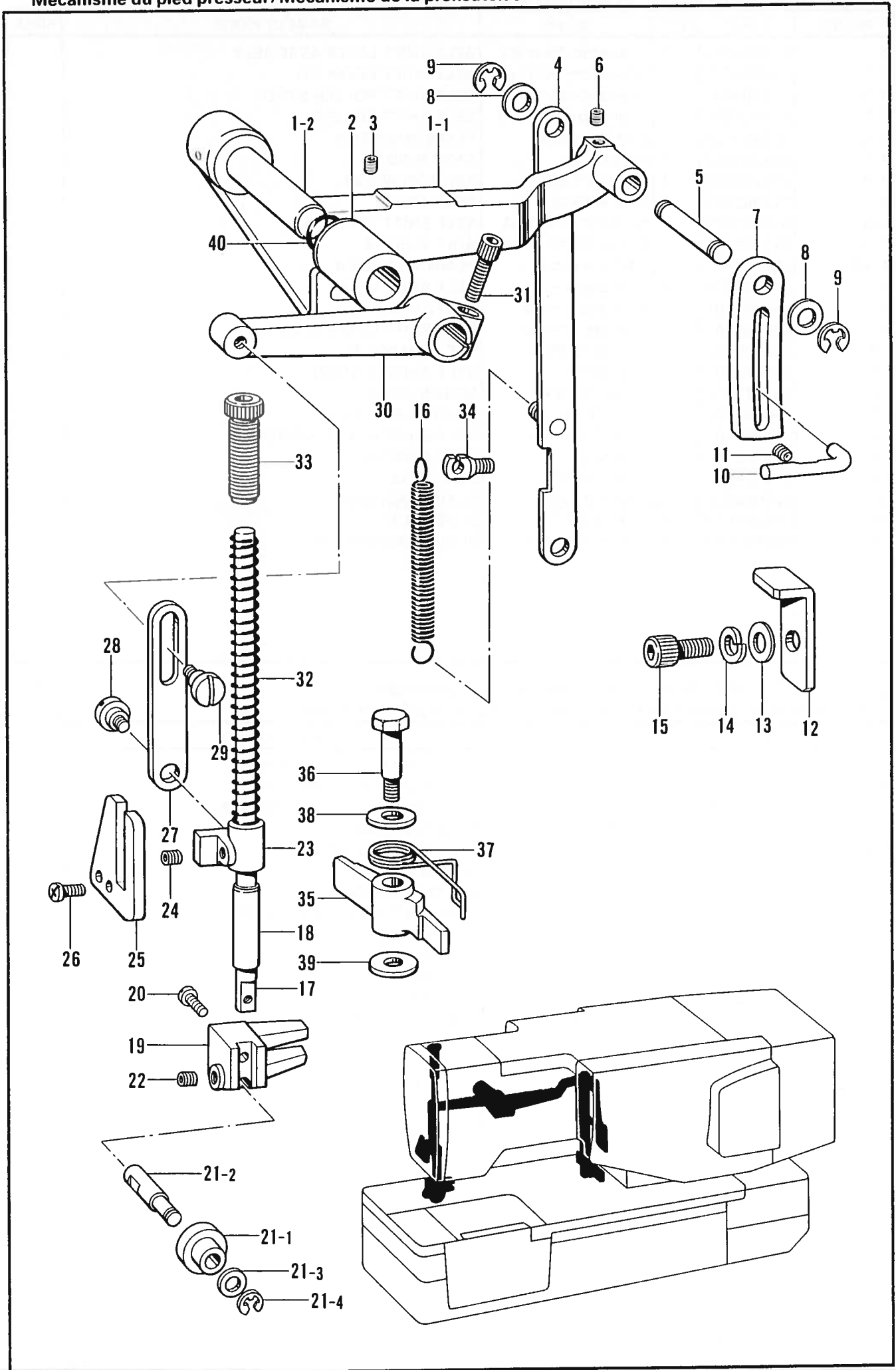

H. 押工関係 / Presser foot mechanism / Stoffdrückerfuß /
 Mécanisme du pied presseur / Mecanismo de la prensatelas

REF. NO.	CODE	Q'TY	ヒンメイ	NAME OF PARTS	RMKS
1	159014101	1	オサエアケ"レハ"ークミ	PRESSER BAR LIFTER LEVER ASSEMBLY	
1-1	159015101	1	オサエアケ"レハ"ー	PRESSER BAR LIFTER LEVER	
1-2	159016001	1	オサエアケ"レハ"ーシ"ク	PRESSER BAR LIFTER LEVER SHAFT	
2	159032000	1	オサイレハ"ーシ"クメタル	PRESSER LEVER SHAFT BUSH	
3	014760622	1	アナトメネシ"5.95	SET SCREW 5.95	
4	159018001	1	オサエアケ"レンカン	PRESSER BAR LIFTER CONNECTING ROD	
5	159020001	1	オサイレンカンシ"ク	PRESSER LIFTER CONNECTING ROD	
6	014760622	1	アナトメネシ"5.95	SET SCREW 5.95	
7	S19828001	1	オサエアケ"アンセ"ンイタ	SAFETY STOPPER	
8	025080232	2	ヒラサ"カ"ネチユウ8	PLAIN WASHER 8	
9	048060342	2	トメフE6	STOP RING E6	
10	159022101	1	オサエアケ"ンイタシ"ク	PRESSER SAFETY STOPPER SHAFT	
11	014760622	1	アナトメネシ"5.95	SET SCREW 5.95	
12	S19830001	1	アンセ"ンイタストツハ"	SAFETY PLATE STOPPER	
13	025080232	1	ヒラサ"カ"ネチユウ8	PLAIN WASHER 8	
14	028080242	1	ハ"ネサ"カ"ネ2-8	SPRING WASHER 2-8	
15	018081622	1	アナホ"ルト8X16	BOLT 8X16	
16	159024001	1	オサエアケ"レンカンハ"ネ	SPRING	
17	159025001	1	オサエホ"ウ	PRESSER BAR	
18	159818001	1	オサエホ"ウメタル	PRESSER BAR BUSH	
19	159026001	1	オサエローライ	PRESSER BAR ROLLER BRACKET	
20	062681212	1	ナヘ"コ437-40X12	SCREW 437X12	
21	159552001	1	オサエローラクミ	PRESSER BAR ROLLER BRACKET ASSEMBLY	
21-1	159027001	1	オサエローラ	PRESSER ROLLER	
21-2	159028001	1	オサエローラシ"ク	PRESSER ROLLER STUD	
21-3	025060132	1	ヒラサ"カ"ネシヨウ6	PLAIN WASHER 6	
21-4	048040342	1	トメフE4	STOP RING E4	
22	014770622	1	アナトメネシ"6.35クホ"ミ	SET SCREW 6.35	
23	159030000	1	オサエホ"ウタ"キ	PRESSER BAR CLAMP	
24	014760622	1	アナトメネシ"5.95	SET SCREW 5.95	
25	159031001	1	オサエアンナイイタ	PRESSER BAR CLAMP GUIDE PLATE	
26	062680812	2	ナヘ"コ437-40X8	SCREW 437X8	
27	S19831001	1	オサエアケ"リンク	PRESSER LIFTER LINK	
28	159394001	1	タ"ンネシ"5.95	STUD SCREW 5.95	
29	145480001	1	タ"ンネシ"6.35	STUD SCREW 6.35	
30	159034000	1	オサエアケ"レハ"ーテコ	PRESSER BAR LIFTER LEVER	
31	018062022	1	アナホ"ルト6X20	BOLT 6X20	
32	159035001	1	オサエハ"ネ	SPRING	
33	100279109	1	オサエチヨウセツネシ"	ADJUST SCREW	
34	141334001	1	ハ"ネカケ	SPRING HOOK	
35	159923001	1	オサエストツフ"レハ"ー	PRESSER STOP LEVER	
36	159924001	1	ストツフ"レハ"ータ"ンネシ"	STOP LEVER STUD SCREW	
37	159925001	1	オサエストツフ"レハ"ーハ"ネ	SPRING	
38	159947001	1	ストツフ"レハ"ーサ"カ"ネ	WASHER	
39	149095001	1	サ"カ"ネ	WASHER	
40	081011670	1	Oリング"PW11	O RING PW11	

J. 送り関係 / Feed mechanism / Transportvorrichtung /
 Mécanisme de l'entraînement / Mecanismo de la alimentación

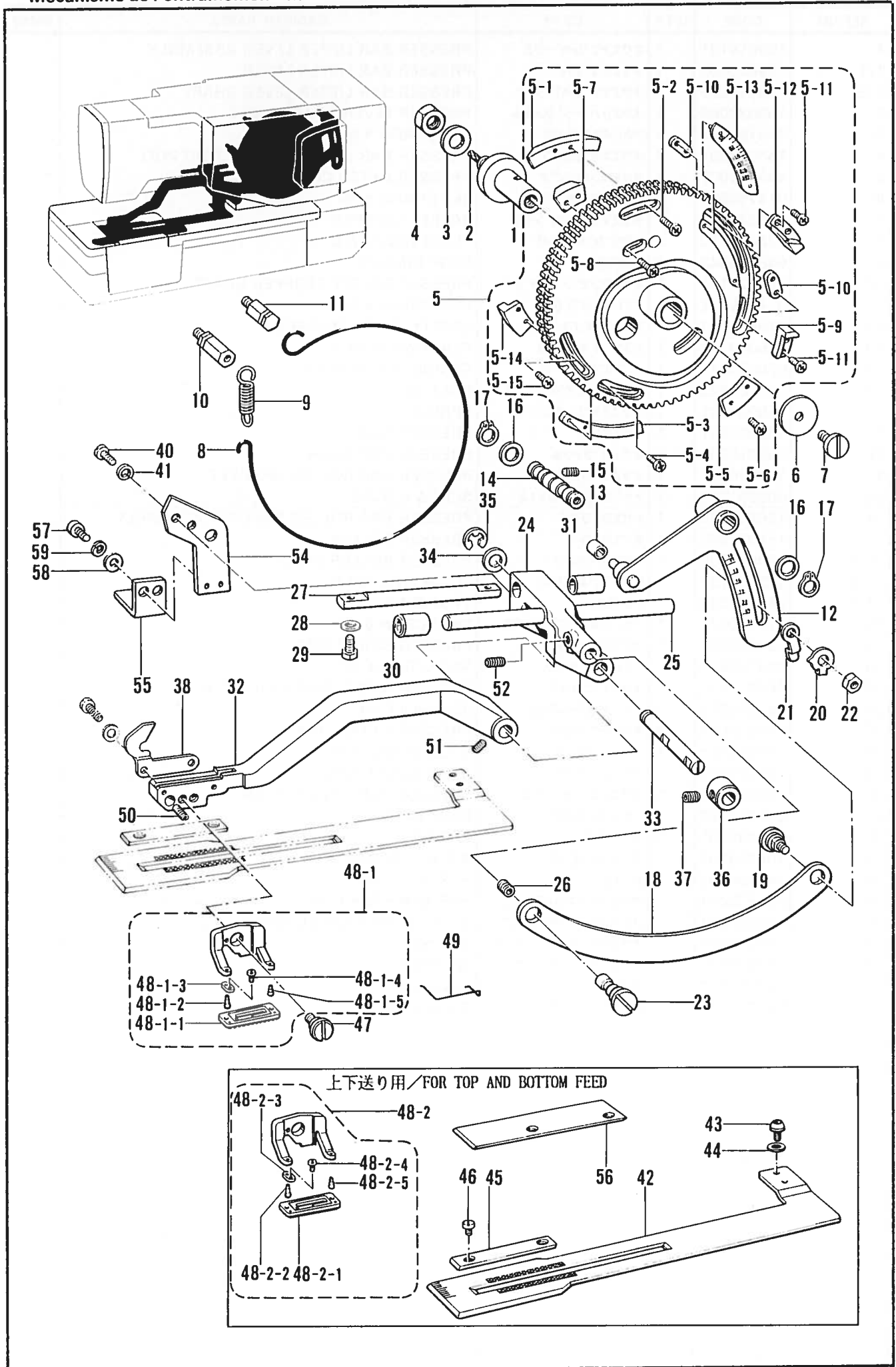

J. 送り関係/Feed mechanism/Transportvorrichtung/
Mécánisme de l'entraînement/Mecanismo de la alimentación

REF.NO.	CODE	Q'TY	ヒンメイ	NAME OF PARTS	RMKS
1	159036001	1	オクリカムシク	FEED CAM SHAFT	
2	159563000	1	クミヒモ	WICK	
3	025900232	1	ヒラサ"カ"ネチユウ12.70	PLAIN WASHER 12.70	
4	021910302	1	ナツト3シユ12.70	NUT 12.70	
5	S11478001	1	オクリカムDクミ	FEED CAM (D) ASSEMBLY	
5-1	159039101	1	イトユルメカムヘンF	TENSION RELEASE CAM SEGMENT (F)	
5-2	062681212	2	ナヘ"コ437-40X12	SCREW 437X12	
5-3	159040101	1	イトユルメカムヘンB	TENSION RELEASE CAM SEGMENT (B)	
5-4	062681212	2	ナヘ"コ437-40X12	SCREW 437X12	
5-5	159041101	1	カント"メカムヘンF	BAR TACK CAM SEGMENT (F)	
5-6	062681012	2	ナヘ"コ437-40X10	SCREW 437X10	
5-7	159042101	1	カント"メカムヘンB	BAR TACK CAM SEGMENT (B)	
5-8	062681012	2	ナヘ"コ437-40X10	SCREW 437X10	
5-9	159043001	1	テイシカムヘンA	STOP CAM SEGMENT (A)	
5-10	159044001	2	テイシカムヘンBサ"カ"ネ	WASHER	
5-11	062681012	4	ナヘ"コ437-40X10	SCREW 437X10	
5-12	159045001	1	テイシカムヘンB	STOP CAM SEGMENT (B)	
5-13	S13020001	1	ケ"ソクシシ"イタ	MODERATION INDICATE PLATE	
5-14	159046001	1	カツタカムヘン	CUTTER CAM SEGMENT	
5-15	062681212	2	ナヘ"コ437-40X12	SCREW 437X12	
6	141400001	1	サ"カ"ネ	WASHER	
7	141408001	1	シメネシ"ヒタ"リ5.95	SCREW 5.95 (LEFT)	
8	159047001	1	オクリカムフ"レーキワイヤ	FEED CAM BRAKE WIRE	
9	159048001	1	フ"レーキワイヤヒキハ"ネ	SPRING	
10	159049001	1	フ"レーキワイヤササエA	BRAKE WIRE HOOK (A)	
11	159050001	1	フ"レーキワイヤササエB	BRAKE WIRE HOOK (B)	
12	159051101	1	オクリチヨウセツレハ"ークミ	FEED ADJUST LEVER ASSEMBLY	
13	107550002	1	コロ	ROLLER	
14	159054001	1	オクリチヨウセツレハ"ーシク	LENGTH FEED ADJUST LEVER SHAFT	
15	014760622	1	アナトメネシ"5.95	SET SCREW 5.95	
16	142628001	2	スイハイオクリクランクリング"	FEED ROCK CRANK RING	
17	048110142	3	トメワシ"クヨウC11	STOP RING C11	
18	159055001	1	オクリレンカン	FEED CONNECTING ROD	
19	159056001	1	タ"ンネシ"6.35	STUD SCREW 6.35	
20	159057001	1	メモリシシ"イタ	LENGTH FEED INDICATOR PLATE	
21	159058101	1	メモリストツハ"A	STOPPER (A)	
22	152750001	1	オクリチヨウセツナツト	FEED ADJUST NUT	
23	S01236001	1	オクリレンカンシ"ク	CONNECTING ROD SHAFT	
24	S13652009	1	オクリウデ"シテン	FEED ARM BRACKET	
25	159062001	1	オクリアンナイシ"クA	FEED GUIDE SHAFT (A)	
26	014760622	1	アナトメネシ"5.95	SET SCREW 5.95	
27	159063001	1	オクリアンナイシ"クB	FEED GUIDE SHAFT (B)	
28	025710232	1	ヒラサ"カ"ネチユウ4.76	PLAIN WASHER 4.76	
29	017711412	2	ボ"ルト4.76X14	BOLT 4.76X14	
30	159064000	1	オクリアンナイシ"クAメタル	FEED GUIDE SHAFT (A) BUSH	
31	142374000	2	DUフ"ツシユ	(DU) BUSH	
32	159065009	1	ナカ"サオクリウデ"	LENGTH FEED ARM	
33	S13651001	1	ナカ"サオクリウデ"シ"ク	LENGTH FEED ARM SHAFT	
34	025100132	1	ヒラサ"カ"ネシヨウ10	PLAIN WASHER 10	
35	048080342	1	トメワE8	STOP RING E8	
36	110495003	1	セツトカラ-	SET COLLAR	
37	014770622	2	アナトメネシ"6.35クホ"ミ	SET SCREW 6.35	
38	S19826001	1	オクリウデ"ササエ	FEED ARM STOPPER	
40	062711412	2	ナヘ"コ476-32X14	SCREW 476X14	
41	028050242	2	ハ"ネサ"カ"ネ2-5	SPRING WASHER 2-5	
42	S01961001	1	ナカ"サオクリイタ	LENGTH FEED PLATE	
43	153057002	2	オクリイタシメネシ"	SCREW	
44	025680232	2	ヒラサ"カ"ネチユウ4.37	PLAIN WASHER 4.37	
45	159071101	1	ナカ"サオクリイタアンナイ	LENGTH FEED GUIDE PLATE	
46	106568003	4	シメネシ"3.57	SCREW 3.57	
47	141439001	1	タ"ンネシ"6.35	STUD SCREW 6.35	

J. 送り関係 / Feed mechanism / Transportvorrichtung /
 Mécanisme de l'entraînement / Mecanismo de la alimentación

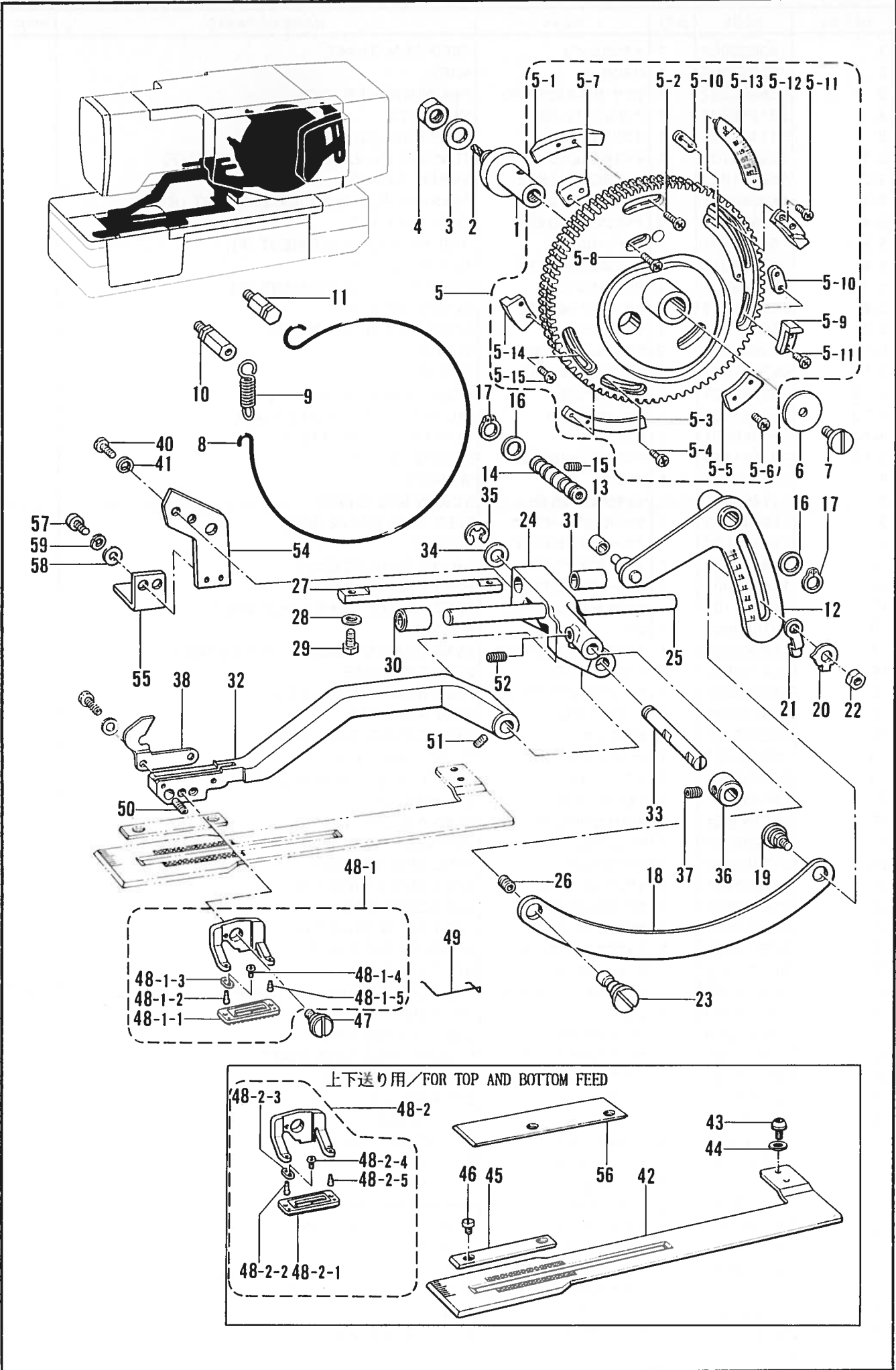

J. 送り関係/Feed mechanism/Transportvorrichtung/
Mécánisme de l'entraînement/Mecanismo de la alimentación

REF.NO.	CODE	Q'TY	ヒンメイ	NAME OF PARTS	RMKS
48-1	159072101	1	ヌツカミ16クミ	UPPER CLAMPING FOOT ASSEMBLY (16MM)	
48-1-1	147113001	1	ヌツカミS	UPPER CLAMPING FOOT (S)	
48-1-2	159926001	1	ヌツカミササエピン L	PIN (L)	
48-1-3	107401001	2	ヌツカミササエイタハ"ネ	PLATE SPRING	
48-1-4	107404001	2	シメネシ"1.98	SCREW 1.98	
48-1-5	159927001	1	ヌツカミササエピン S	PIN (S)	
48-2	158982101	1	ヌツカミ16Rクミ	UPPER CLAMPING FOOT ASSEMBLY (16R)	
48-2-1	159581001	1	ヌツカミ16R	UPPER CLAMPING FOOT (16MM) RUBBER	
48-2-2	159926001	1	ヌツカミササエピン L	PIN (L)	
48-2-3	107401001	2	ヌツカミササエイタハ"ネ	PLATE SPRING	
48-2-4	107404001	2	シメネシ"1.98	SCREW 1.98	
48-2-5	159927001	1	ヌツカミササエピン S	PIN (S)	
49	159079000	1	フィンガ"ーカ"ートS	FINGER GUARD (S)	
50	159078001	1	ヌツカミササエハ"ネ	SPRING	
51	014760622	1	アトメネシ"5.95	SET SCREW 5.95	
52	014760622	2	アトメネシ"5.95	SET SCREW 5.95	
54	S13649001	1	シタオクリウテ"U	BOTTOM FEED ARM (U)	
55	S13650001	1	シタオクリウテ"D	BOTTOM FEED ARM (D)	
56	S01962001	1	ナカ"サオクリイタアンナイ	LENGTH FEED GUIDE PLATE	
57	153057002	2	オクリイタシメネシ"	SCREW	
58	025680232	2	ヒラサ"カ"ネチユウ4.37	PLAIN WASHER 4.37	
59	028680242	2	ハ"ネサ"カ"ネ2-4.37	SPRING WASHER 2-4.37	

K. カム伝導関係 / Feed cam mechanism / Transporteurkurve /
 Mécanisme de la came d'entraînement / Mecanismo de la leva de alimentación

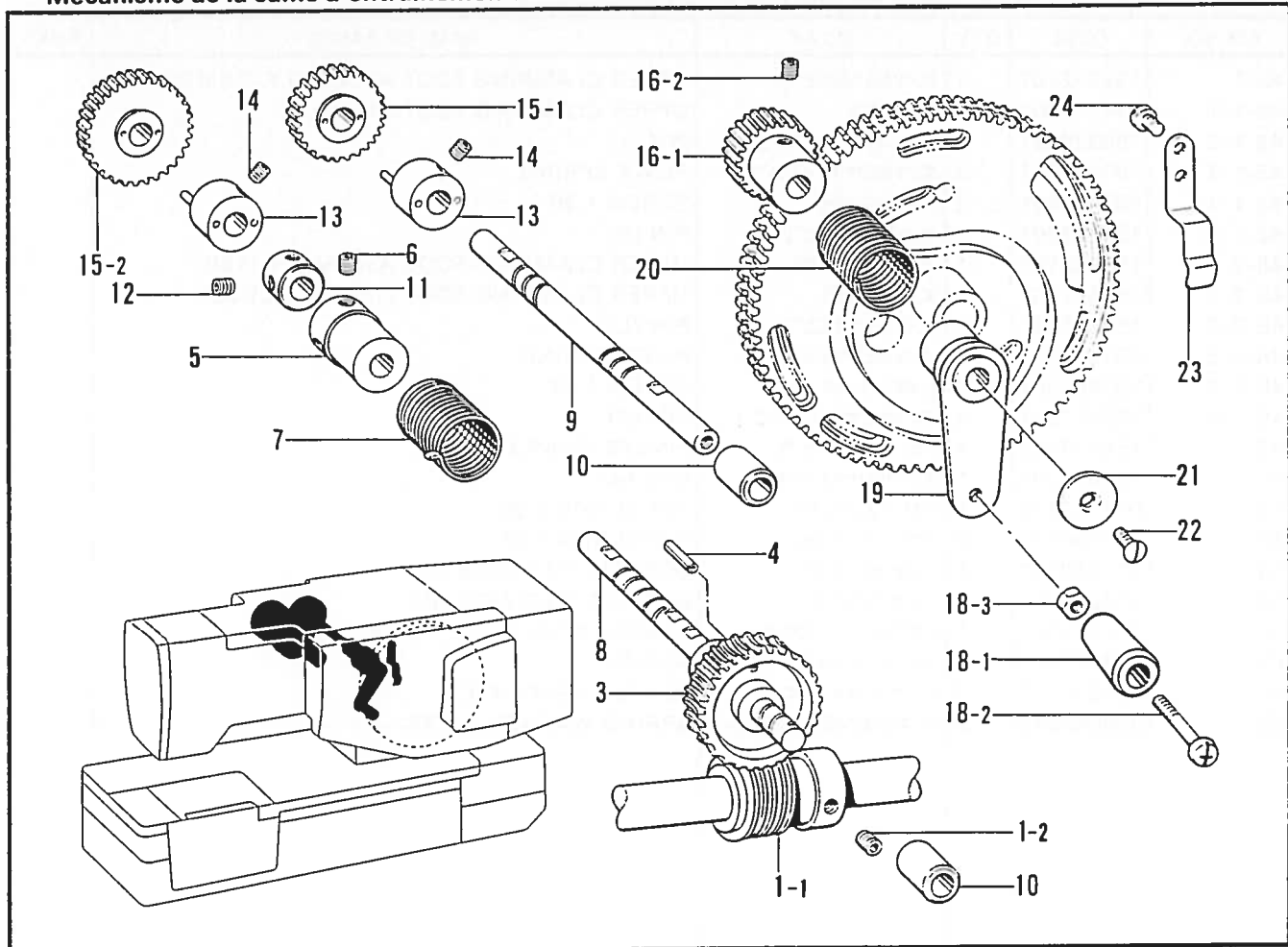

L. 糸切れ感知関係 / Thread breakage detector mechanism / Fadenbruchfühler /
 Mécanisme du détecteur de cassure du fil / Mecanismo del sensor de cortes de hilo

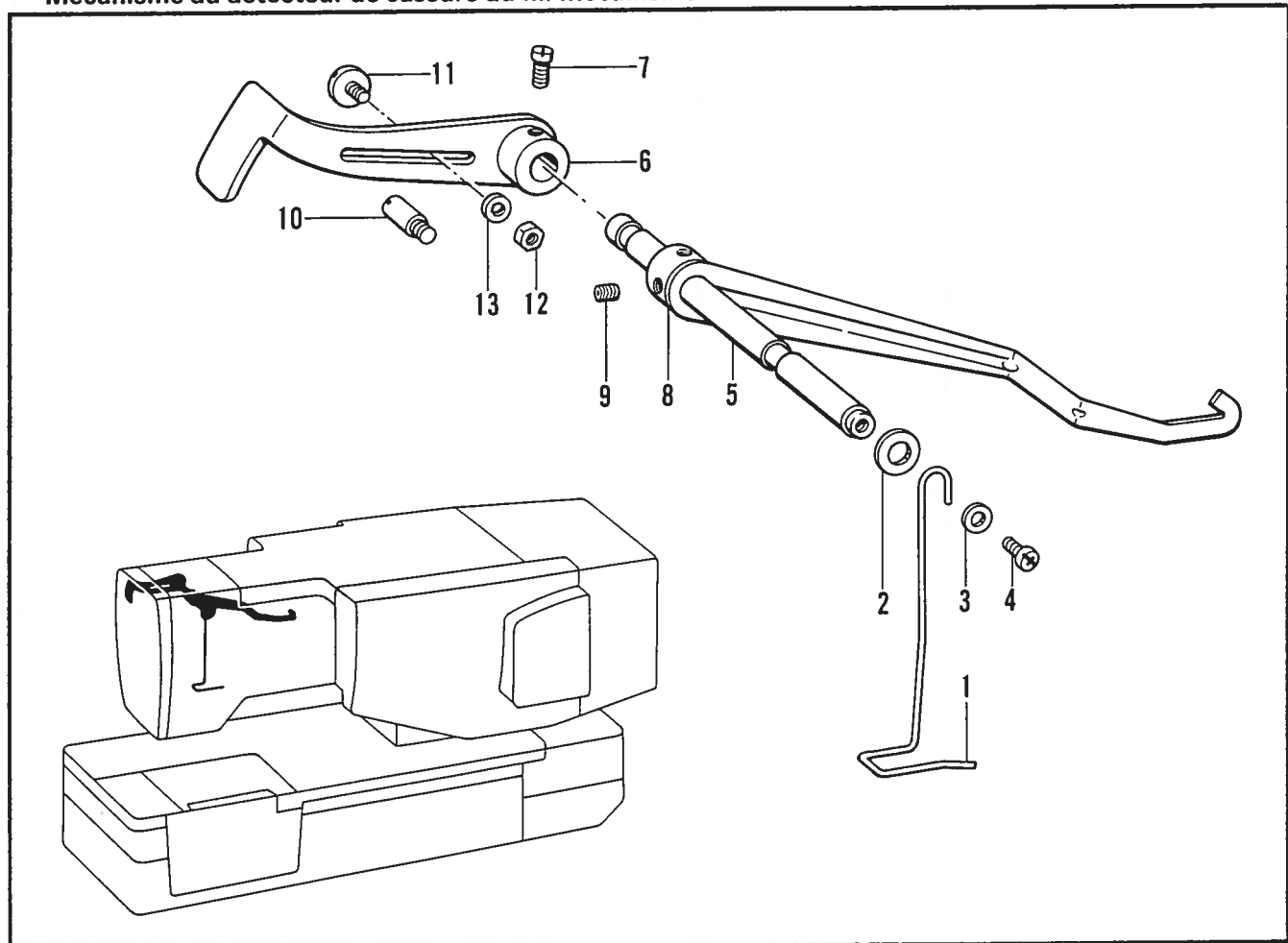

K. カム伝導関係 / Feed cam mechanism / Transporteurkurve /
Mécanisme de la came d'entraînement / Mecanismo de la leva de alimentación

REF.NO.	CODE	Q'TY	ヒンメイ	NAME OF PARTS	RMKS
1	183704001	1	ウオームクミ	WORM ASSEMBLY	
1-1	141367001	1	ウオーム	WORM	
1-2	014770622	2	アナトメネシ"6.35クホ"ミ	SET SCREW 6.35	
3	159082000	1	ウオームホイール	WORM WHEEL	
4	047301842	1	スプリング"ピンAW3	SPRING PIN AW3	
5	S13634001	1	ワンウェイクラッチカラ-	ONE WAY CLUTCH COLLAR	
6	014770622	2	アナトメネシ"6.35クホ"ミ	SET SCREW 6.35	
7	S13635001	1	ワンウェイクラッチハ"ネ	SPRING	
8	S13633001	1	ウオームホイールシ"ク	WORM WHEEL SHAFT	
9	159086001	1	チェンジ"キ"ヤシ"ク	CHANGE GEAR SHAFT	
10	159087000	2	キ"ヤシ"クメタル	GEAR SHAFT BUSH	
11	110495003	1	セツトカラ-	SET COLLAR	
12	014770622	2	アナトメネシ"6.35クホ"ミ	SET SCREW 6.35	
13	159088001	2	キ"ヤシ"クカラークミ	GEAR SHAFT COLLAR ASSEMBLY	
14	014770622	4	アナトメネシ"6.35クホ"ミ	SET SCREW 6.35	
15-1	141378000	1	チェンジ"キ"ヤ34	CHANGE GEAR 34	
15-2	141382000	1	チェンジ"キ"ヤ42	CHANGE GEAR 42	
16	183708001	1	フリーホイールキ"ヤクミ	FREE WHEEL GEAR	
16-1	159090001	1	フリーホイールキ"ヤ	FREE WHEEL GEAR	
16-2	014770622	2	アナトメネシ"6.35クホ"ミ	SET SCREW 6.35	
18	159091009	1	ハンド"ル"クミ	HANDLE ASSEMBLY	
18-1	159093009	1	ハンド"ル	HANDLE	
18-2	112700001	1	シメネシ"5.95	SCREW 5.95	
18-3	106588003	1	ナツト5.95	NUT 5.95	
19	159092001	1	ハンド"ルレハ"ー	HANDLE LEVER	
20	159094001	1	ハンド"ルクラッチハ"ネ	SPRING	
21	151932001	1	ジ"クウケフタ	BEARING COVER	
22	107231002	1	サラネシ"4.76	SCREW 4.76	
23	159095101	1	ハンド"ルストツハ°	HANDLE STOPPER	
24	062680612	1	ナヘ"コ437-40X6	SCREW 437X6	

L. 糸切れ感知関係 / Thread breakage detector mechanism / Fadenbruchfühler /
Mécanisme du détecteur de cassure du fil / Mecanismo del sensor de cortes de hilo

REF.NO.	CODE	Q'TY	ヒンメイ	NAME OF PARTS	RMKS
1	S19814001	1	イトキレカンチイトアンナイ	THREAD BREAKAGE PERCEIVING GUIDE	
2	025060232	1	ヒラサ"カ"ネチユウ 6	PLAIN WASHER 6	
3	025350332	1	ヒラサ"カ"ネタ"イ3.5	PLAIN WASHER 3.5	
4	062670612	1	ナヘ"コ357-40X6	SCREW 357X6	
5	159145001	1	イトキレカンチレハ"ーシ"ク	THREAD BREAKAGE PERCEIVING LEVER SHAFT	
6	159146101	1	イトキレカンチレハ"ー	THREAD BREAKAGE PERCEIVING LEVER	
7	104908004	1	アタマツキトメネシ"4.37	SET SCREW 4.37	
8	S19815001	1	カツタクラッチストツハ°	CUTTER CLUTCH STOPPER	
9	014680622	2	アナトメネシ"4.37クホ"ミ	SET SCREW 4.37	
10	159148001	1	カンチレハ"ーストツハ°	THREAD BREAKAGE PERCEIVING LEVER STOPPER	
11	105451002	1	シメネシ"3.57	SCREW 3.57	
12	021670202	1	ナツト2シユ3.57	NUT 3.57	
13	025350332	1	ヒラサ"カ"ネタ"イ3.5	PLAIN WASHER 3.5	

M. カッター関係 / Cutter mechanism / Abschneidevorrichtung /
 Mécanisme de la coupe / Mecanismo de la corta

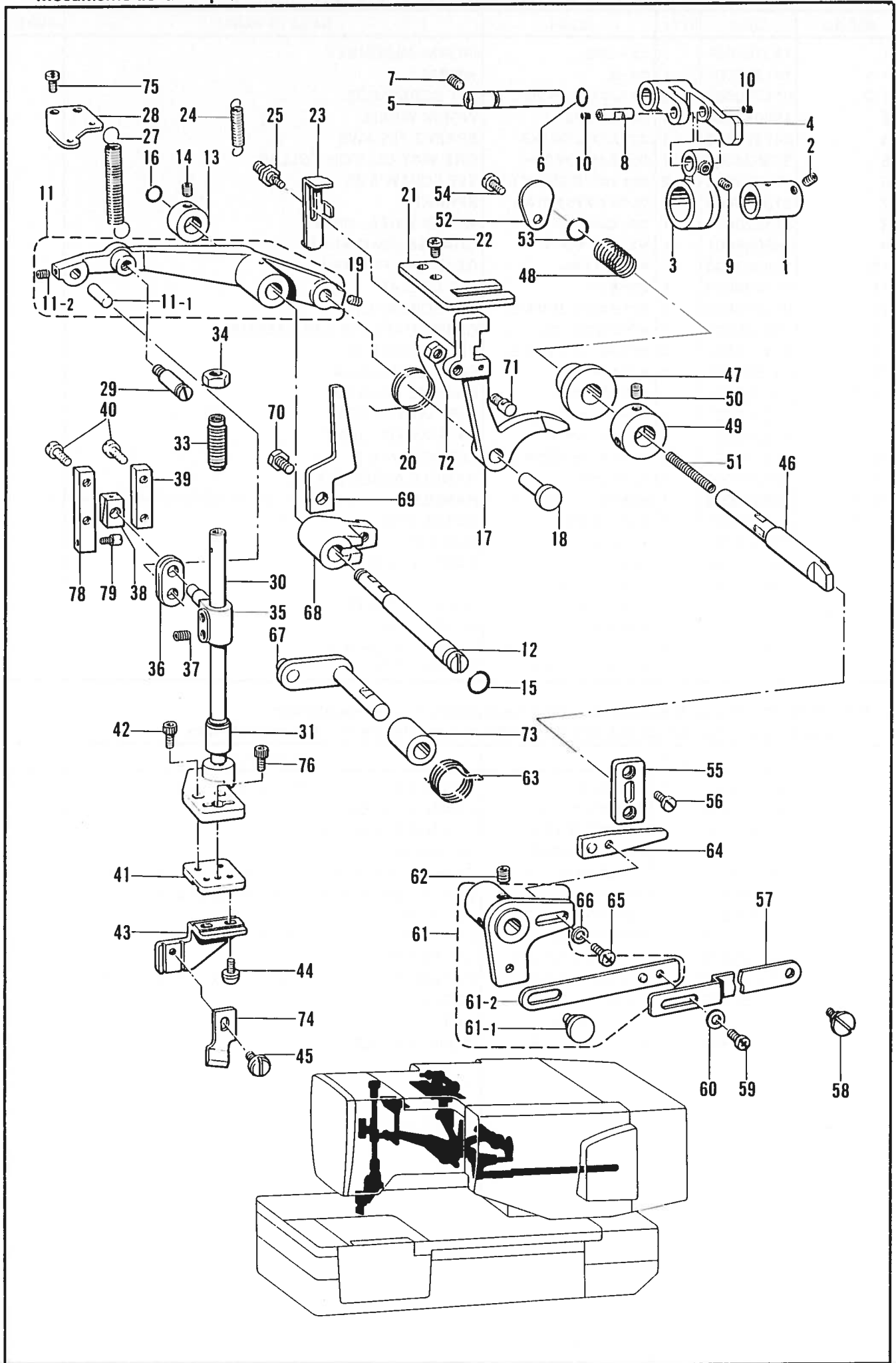

M. カッター関係 /Cutter mechanism/Abschneidevorrichtung/
Mécanisme de la coupe/Mecanismo de la corta

REF NO.	CODE	Q'TY	ヒンメイ	NAME OF PARTS	RMKS
1	159096001	1	カッタヘンシンリン	CUTTER ECCENTRIC WHEEL	
2	014770622	2	アナトメネシ"6.35クホ"ミ	SET SCREW 6.35	
3	159097001	1	カッタヘンシンリンロツト	CUTTER ECCENTRIC ROD	
4	159098001	1	カッタクト"ウレハ"ー	CUTTER DRIVING LEVER	
5	159099001	1	カッタクト"ウレハ"ーシ"ク	CUTTER DRIVING LEVER SHAFT	
6	081007070	1	Oリング"P7	O RING P7	
7	014760622	1	アナトメネシ"5.95	SET SCREW 5.95	
8	159100001	1	Cヘンシンリンロツトピン	PIN	
9	014680622	1	アナトメネシ"4.37クホ"ミ	SET SCREW 4.37	
10	159101000	2	メクラセン	OIL CAP	
11	159102001	1	カッタサト"ウウデ"クミ	CUTTER DRIVING ARM ASSEMBLY	
11-1	159104001	1	Cサト"ウウデ"ピン	PIN	
11-2	014680622	1	アナトメネシ"4.37クホ"ミ	SET SCREW 4.37	
12	159105001	1	カッタサト"ウウデ"シ"ク	CUTTER DRIVING ARM SHAFT	
13	159491001	1	セツトカラー	SET COLLAR	
14	014760622	2	アナトメネシ"5.95	SET SCREW 5.95	
15	081011070	1	Oリング"P11	O RING P11	
16	081006670	1	Oリング"PW6	O RING PW6	
17	159106001	1	Cクラツチ	CUTTER CLUTCH	
18	159107001	1	Cクラツチサト"ウピン	PIN	
19	014760622	1	アナトメネシ"5.95	SET SCREW 5.95	
20	159108001	1	カッタクラツチハ"ネ	SPRING	
21	159109001	1	カッタクラツチアンナイ	CUTTER CLUTCH GUIDE	
22	062761212	2	ナヘ"コ595-28X12	SCREW 595X12	
23	159110001	1	Cクラツチアンナイイタ	CUTTER CLUTCH GUIDE PLATE	
24	159111001	1	Cクラツチアンナイハ"ネ	SPRING	
25	159112001	1	ハ"ネカケ	SPRING HOOK	
27	159114001	1	カッタモト"シハ"ネ	SPRING	
28	159115001	1	カッタモト"シハ"ネカケイタ	SPRING HOOK PLATE	
29	159395001	1	ハ"ネカケシ"ク	SPRING HOOK PIN	
30	159116001	1	カッタサト"ウシ"ク	CUTTER DRIVING SHAFT	
31	159117001	1	カッタサト"ウシ"クメタル	CUTTER DRIVING SHAFT BUSH	
33	159119101	1	チヨウセツネシ"クミ	ADJUST SCREW ASSEMBLY	
34	021910302	1	ナツト3シユ12.70	NUT 12.70	
35	159120001	1	カッタサト"ウシ"クホルタ"ー	CUTTER DRIVING SHAFT HOLDER	
36	159329001	1	カッタサト"ウリンク	CUTTER DRIVING LINK	
37	014770622	2	アナトメネシ"6.35クホ"ミ	SET SCREW 6.35	
38	159570001	1	カッタアンナイカクコマ	CUTTER GUIDE BLOCK	
39	159121001	1	カッターホ"ウアンナイ	CUTTER BAR GUIDE	
40	062761212	4	ナヘ"コ595-28X12	SCREW 595X12	
41	159122001	1	カッタホルタ"ーU	CUTTER HOLDER (U)	
42	018680822	2	アナホ"ルト4.37X8	BOLT 4.37X8	
43	159123001	1	カッタホルタ"ーD	CUTTER HOLDER (D)	
44	153057002	2	オクリイタシメネシ"	SCREW	
45	115503001	1	シメネシ"4.37	SCREW 4.37	
46	159124001	1	カッタオシホ"ウ	CUTTER CONNECTING SHAFT	
47	159126001	1	Cクラツチカラー	CUTTER CLUTCH COLLAR	
48	159127001	1	カラーオシハ"ネ	SPRING	
49	159128001	1	Cクラツチセツトカラー	CUTTER CLUTCH SET COLLAR	
50	014770622	2	アナトメネシ"6.35クホ"ミ	SET SCREW 6.35	
51	159129001	1	カッタクラツチホ"ウオシハ"ネ	SPRING	
52	159130001	1	ハ"ネアンナイササエ	SPRING GUIDE SUPPORT	
53	081011070	1	Oリング"P11	O RING P11	
54	062710812	1	ナヘ"コ476-32X8	SCREW 476X8	
55	159131101	1	Cクラツチシ"クアンナイイタ	CUTTER CLUTCH SHAFT GUIDE PLATE	
56	107407003	2	シメネシ"4.37	SCREW 4.37	
57	159132001	1	カッタテイシレンカンL	CUTTER STOPPER CONNECTING PLATE (L)	
58	159908001	1	タ"ンネシ"4.37	STUD SCREW 4.37	
59	062680612	2	ナヘ"コ437-40X6	SCREW 437X6	
60	025680132	2	ヒラサ"カ"ネシヨウ4.37	PLAIN WASHER 4.37	

M. カッター関係 / Cutter mechanism / Abschneidevorrichtung /
 Mécanisme de la coupe / Mecanismo de la corta

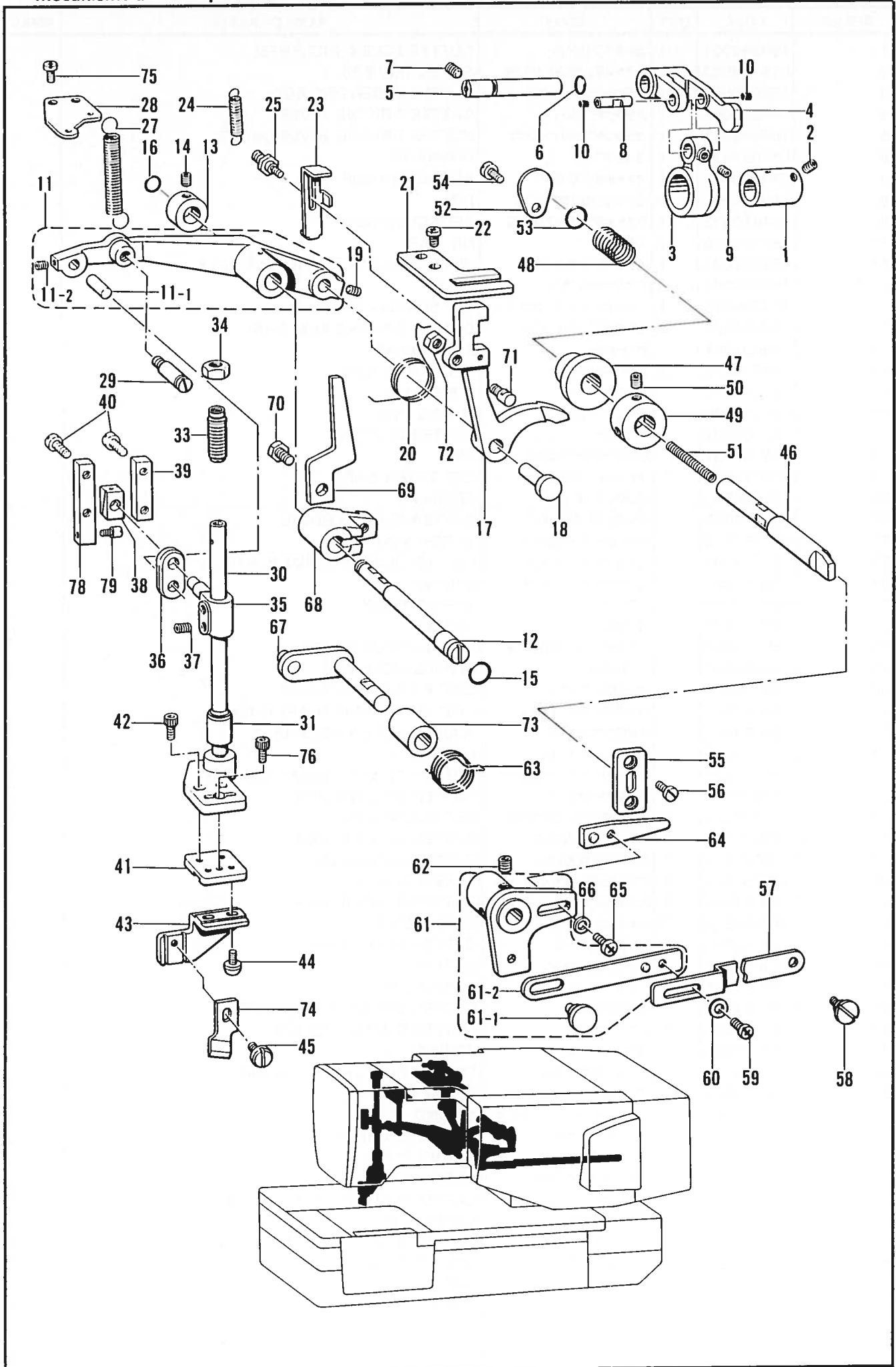

M. カッター関係 /Cutter mechanism/Abschneidevorrichtung/
 Mécanisme de la coupe/Mecanismo de la corta

REF NO.	CODE	Q'TY	ヒンメイ	NAME OF PARTS	RMKS
61	158824001	1	カッタテシレハークミ	CUTTER STOP LEVER ASSEMBLY	
61-1	159133001	1	テシレンカンカシメピン	PIN	
61-2	158823001	1	カッタテシレンカンS	CUTTER STOPPER CONNECTING PLATE (S)	
62	014770622	2	アナトメネジ"6.35クホ"ミ	SET SCREW 6.35	
63	S19801001	1	カッタテシレハークミ	CUTTER STOPPER LEVER SPRING	
64	159136001	1	カッタハズシセツシヨクシ	CUTTER DETATCH LEVER	
65	062680612	2	ナヘ"コ437-40X6	SCREW 437X6	
66	025680132	2	ヒラサ"カ"ネシヨウ4.37	PLAIN WASHER 4.37	
67	159137001	1	カッタテシレハークミ	CUTTER STOPPER LEVER SHAFT ASSEMBLY	
68	159140001	1	Cテシレハークミ	CUTTER STOPPER LEVER BRACKET	
69	159141001	1	Cクラツチテシレハークミ	CUTTER STOPPER LEVER PLATE	
70	017771412	1	ボルト6.35X14	BOLT 6.35X14	
71	159142101	1	カッタテシレハークミ	PIN	
72	150554002	1	ナツト6.35	NUT 6.35	
73	159143000	1	アンセ"ンレハークミ	CUTTER DROP SAFETY LEVER SHAFT BUSH	
74	107200001	1	カッタ1/2	CUTTER 1/2	
75	062680812	2	ナヘ"コ437-40X8	SCREW 437X8	
76	018680522	1	アナボルト4.37X5	BOLT 4.37X5	
78	S02807001	1	カッターボウアンナイフ	CUTTER BAR GUIDE (F)	
79	115120001	1	ハリカス"ヘンカンキ"ヤピン	PIN	

N. カマ関係 / Rotary hook mechanism / Greifervorrichtung /
 Mécanisme du crochet rotatif / Mecanismo del cangrejo

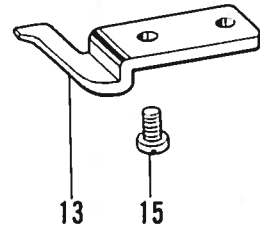
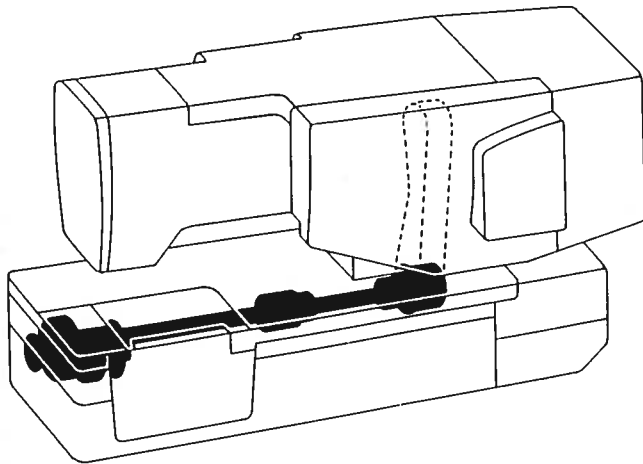
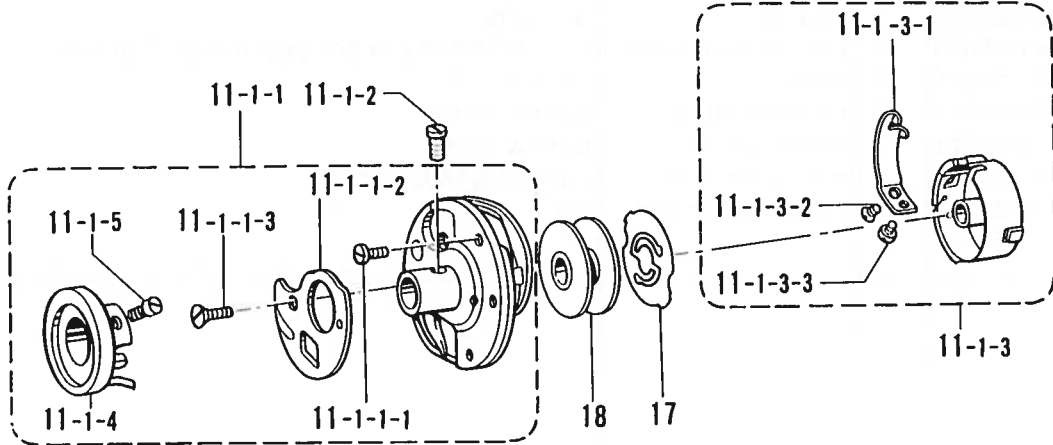
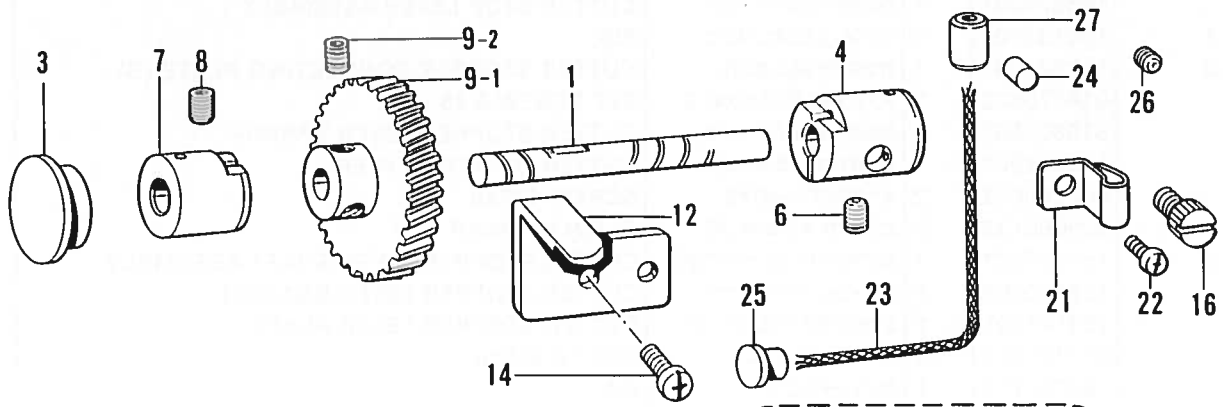

補給用 / FOR SUPPLY

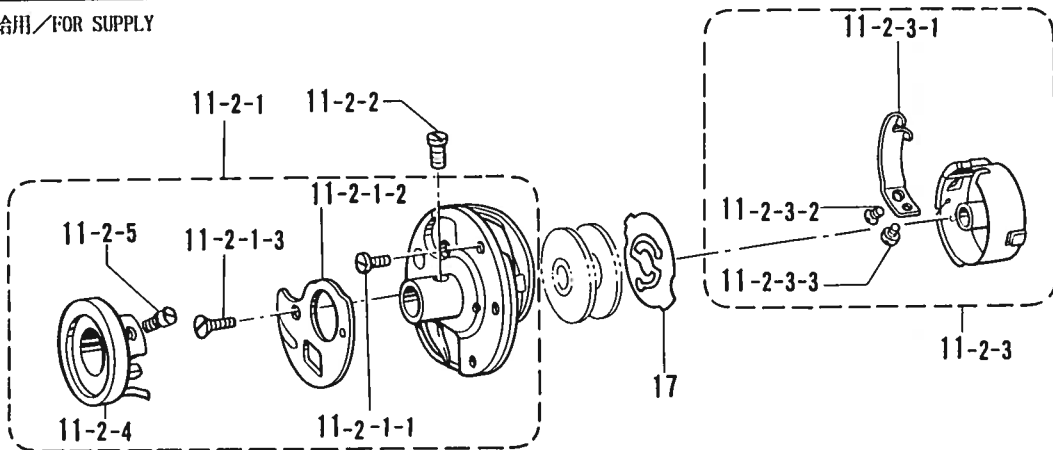

N. カマ関係 / Rotary hook mechanism / Greifervorrichtung /
Mécánisme du crochet rotatif / Mecanismo del cangrejo

REF. NO.	CODE	Q'TY	ヒンメイ	NAME OF PARTS	RMKS
1	S19895001	1	カマジ"ク	ROTARY HOOK SHAFT	
3	159150009	1	カマジ"クメクラセン	OIL CAP	
4	S19841001	1	カマジ"クメタルR	ROTARY HOOK SHAFT BUSH (R)	
6	014760622	1	アナトメネジ"5.95	SET SCREW 5.95	
7	S19847001	1	カマジ"クメタルF	ROTARY HOOK SHAFT BUSH (F)	
8	014760622	1	アナトメネジ"5.95	SET SCREW 5.95	
9	183709001	1	カマジ"クキ"ヤクミ	ROTARY HOOK SHAFT GEAR ASSEMBLY	
9-1	159154001	1	カマジ"クキ"ヤ	ROTARY HOOK SHAFT GEAR	
9-2	014770622	2	アナトメネジ"6.35クホ"ミ	SET SCREW 6.35	
11-1	S19898001	1	カマホ"ヒ"ンケースクミ	ROTARY HOOK BOBBIN CASE	
11-1-1	S19893001	1	カマクミ	ROTARY HOOK ASSEMBLY	
11-1-1-1	183508001	3	ナカカマオサエシメネジ"	SCREW	
11-1-1-2	183596001	1	カマウライタ	ROTARY HOOK REAR PLATE	
11-1-1-3	183598001	1	ウライタシメネジ"	SCREW	
11-1-2	183490001	2	B815ソトカマトメネジ"	OUTER ROTARY HOOK SET SCREW	
11-1-3	S01870001	1	Pホ"ヒ"ンケースクミ	BOBBIN CASE ASSEMBLY (P)	
11-1-3-1	S09477001	1	ホ"ヒ"ンチヨウシハ"ネ	SPRING	
11-1-3-2	180721001	1	チヨウシハ"ネシメネジ"	SCREW	
11-1-3-3	183507001	1	チヨウシネジ"	ADJUST SCREW	
11-1-4	S19894001	1	カマキユウユリング"	RING	
11-1-5	S20014001	2	キユウユリング"トメネジ"	SET SCREW	
12	159159001	1	カマトメA	ROTARY HOOK HOLDER (A)	
13	159160000	1	カマトメB	ROTARY HOOK HOLDER (B)	
14	062711012	2	ナヘ"コ476-32X10	SCREW 476X10	
15	062680612	2	ナヘ"コ437-40X6	SCREW 437X6	
16	S19836001	1	キユウユチヨウセツネジ"	OIL SUPPLY ADJUST SCREW	
18	159158001	1	ホ"ヒ"ン	BOBBIN	
21	S19838001	1	キユウユネジ"オサエ	OIL SUPPLY SCREW PRESSER	
22	062680612	1	ナヘ"コ437-40X6	SCREW 437X6	
23	S19839000	1	クミヒモ2X150	WICK 2X150	
24	S19837001	1	キユウユチヨウセツタイ	OIL SUPPLY ADJUST COLLAR	
25	117934009	1	メクラセン	OIL CAP	
26	143793001	2	シールシメネジ"6.35-40	SET SCREW 6.35-40	
27	S19840001	1	トウジンカラー	COLLAR	
<ホキユウヨウ / FOR SUPPLY >					
11-2	S19899001	1	カマホ"ヒ"ンケースクミ	ROTARY HOOK BOBBIN CASE ASSEMBLY	
11-2-1	S19897001	1	カマクミ	ROTARY HOOK ASSEMBLY	
11-2-1-1	183526001	3	ナカカマオサエシメネジ"	SCREW	
11-2-1-2	183596001	1	カマウライタ	ROTARY HOOK REAR PLATE	
11-2-1-3	183598001	1	ウライタシメネジ"	SCREW	
11-2-2	183490001	2	B815ソトカマトメネジ"	OUTER ROTARY HOOK SET SCREW	
11-2-3	S01870001	1	Pホ"ヒ"ンケースクミ	BOBBIN CASE ASSEMBLY (P)	
11-2-3-1	S09477001	1	ホ"ヒ"ンチヨウシハ"ネ	SPRING	
11-2-3-2	180721001	1	チヨウシハ"ネシメネジ"	SCREW	
11-2-3-3	183507001	1	チヨウシネジ"	ADJUST SCREW	
11-2-4	S19894001	1	カマキユウユリング"	RING	
11-2-5	S20014001	2	キユウユリング"トメネジ"	SET SCREW	
17	S01109001	1	ホ"ヒ"ンオサエハ"ネ	SPRING	

**P 下軸関係 / Lower shaft mechanism / Untere Welle /
Mécanisme de l'arbre inférieur / Mecanismo del eje inferior**

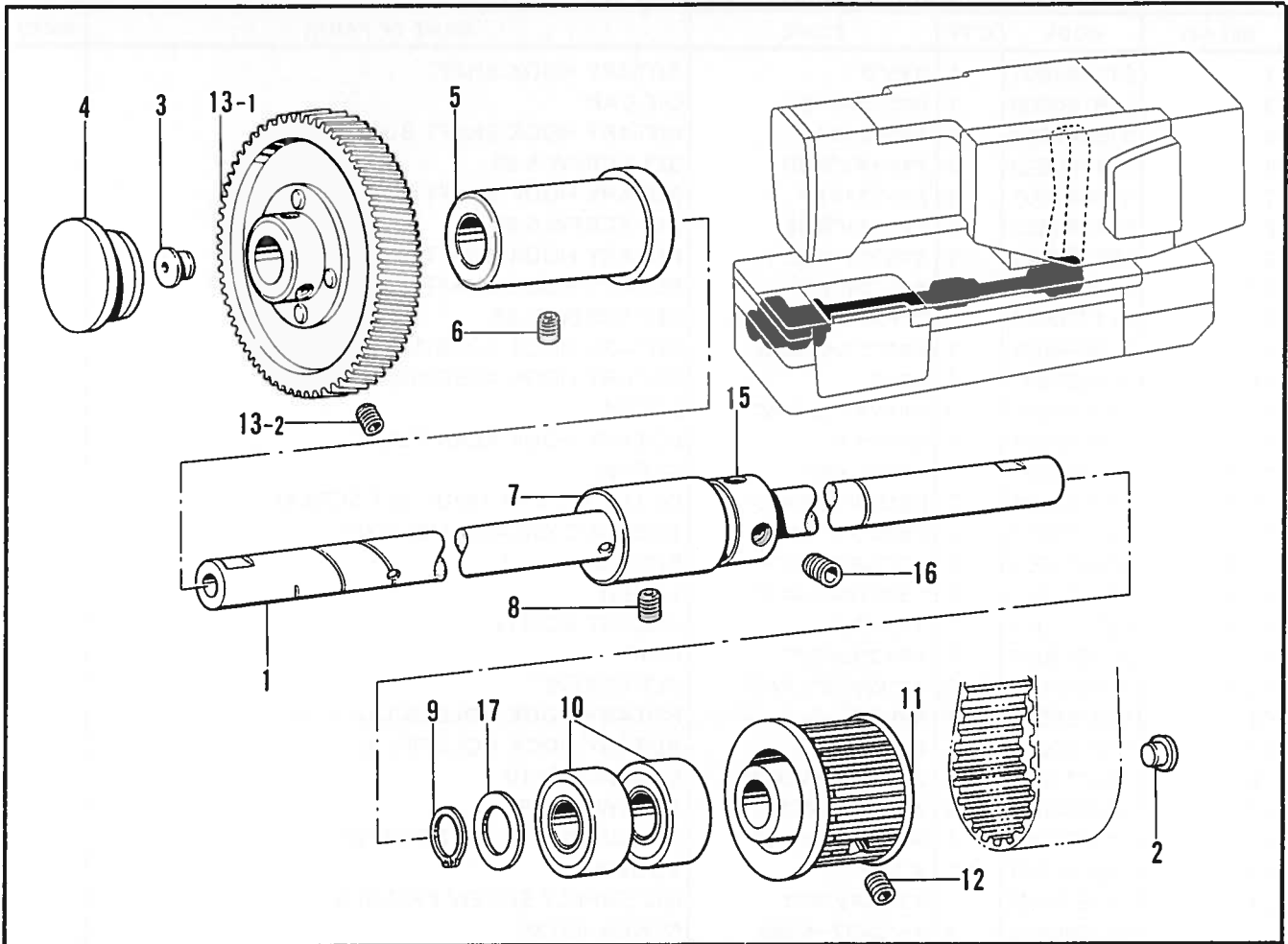

**Q. OP 頭部組付関係 / Single pedal mechanism installed in the head / Maschineoberteil Mit Einem Pedal /
Mécanisme de l'ensemble de la tête pour une machine avec une seule pédale /
Mecanismo del conjunto de cabeza (de máquina) con pedal sencillo**

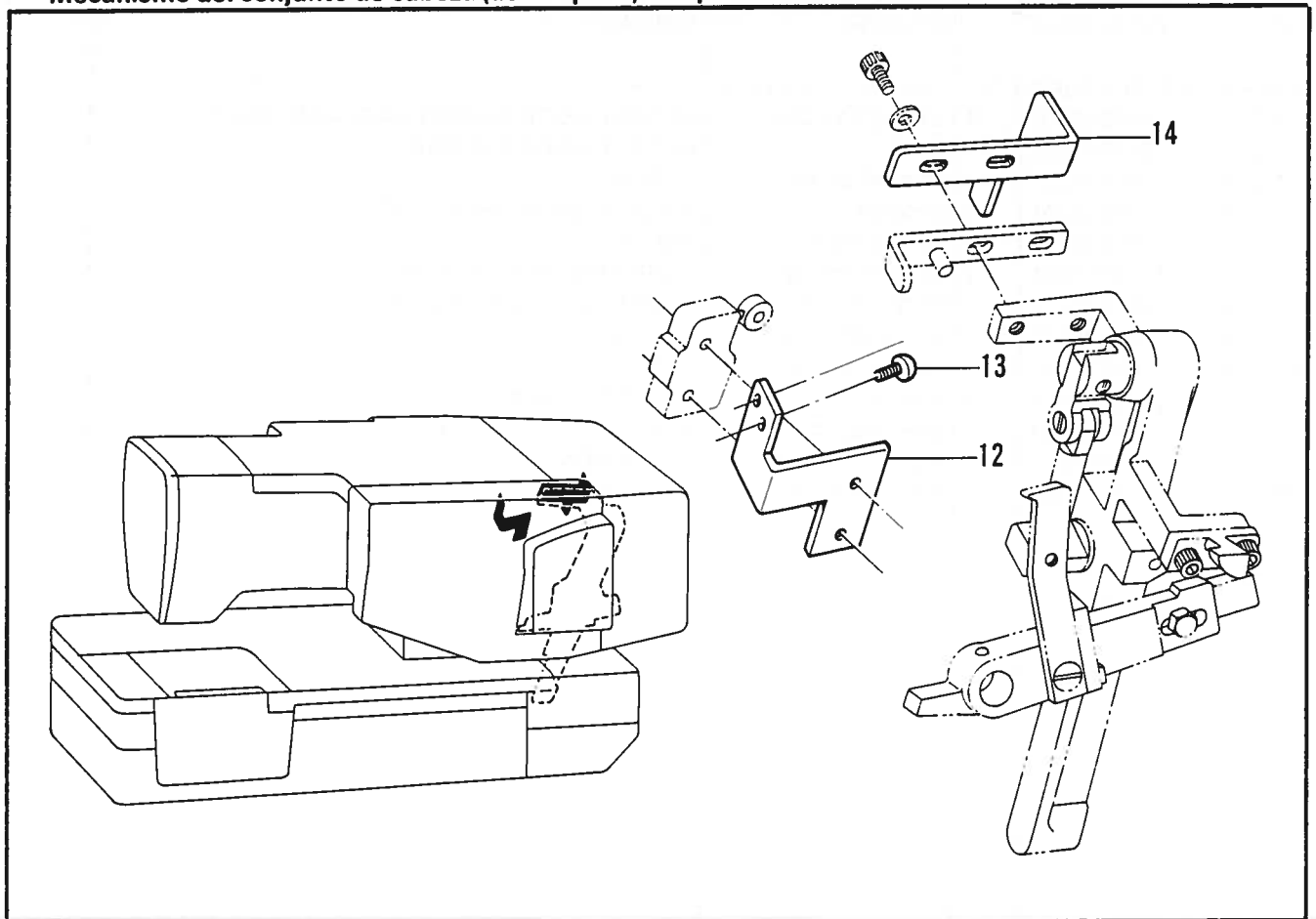

P. 下軸関係 / Lower shaft mechanism / Untere Welle /
 Mécanisme de l'arbre inférieur / Mecanismo del eje inferior

REF.NO.	CODE	Q'TY	ヒンメイ	NAME OF PARTS	RMKS
1	159162001	1	シタジ"ク	LOWER SHAFT	
2	104450109	1	メクラセン	OIL CAP	
3	114255002	1	キャツプ	CAP	
4	159163009	1	シタジ"クメクラセン	OIL CAP	
5	159164001	1	シタジ"クメタルF	LOWER SHAFT BUSH (F)	
6	014760622	1	アナトメネシ"5.95	SET SCREW 5.95	
7	158893000	1	ウツジ"クメタルM	UPPER SHAFT BUSH (M)	
8	014760622	1	アナトメネシ"5.95	SET SCREW 5.95	
9	048150142	1	トメワシ"クヨウC15	STOP RING C15	
10	072620200	2	タマシ"クウケ6202	BALL BEARING 6202	
11	159745100	1	Dタイミング"プーリックミ	LOWER TIMING PULLEY ASSEMBLY	
12	014760622	4	アナトメネシ"5.95	SET SCREW 5.95	
13	183710001	1	シタジ"クキ"ヤクミ	LOWER SHAFT GEAR ASSEMBLY	
13-1	159166001	1	シタジ"クキ"ヤクミ	LOWER SHAFT GEAR ASSEMBLY	
13-2	014770622	2	アナトメネシ"6.35クホ"ミ	SET SCREW 6.35	
15	159169001	1	シタジ"クセットカラー	LOWER SHAFT SET COLLAR	
16	014770622	2	アナトメネシ"6.35クホ"ミ	SET SCREW 6.35	
17	116920001	1	オクリシ"クスラストリング"	THRUST RING	

Q. O P 頭部組付関係 / Single pedal mechanism installed in the head / Maschineoberteil Mit Einem Pedal /
 Mécanisme de l'ensemble de la tête pour une machine avec une seule pédale /
 Mecanismo del conjunto de cabeza (de máquina) con pedal sencillo

REF.NO.	CODE	Q'TY	ヒンメイ	NAME OF PARTS	RMKS
12	S00793001	1	クラツチSWトリツケイタ	CLUTCH SWITCH SET PLATE	
13	062680712	2	ナヘ"コ437-40X7	SCREW 437X7	
14	S00794001	1	クラツチSWト"ク"	CLUTCH SWITCH DOG	

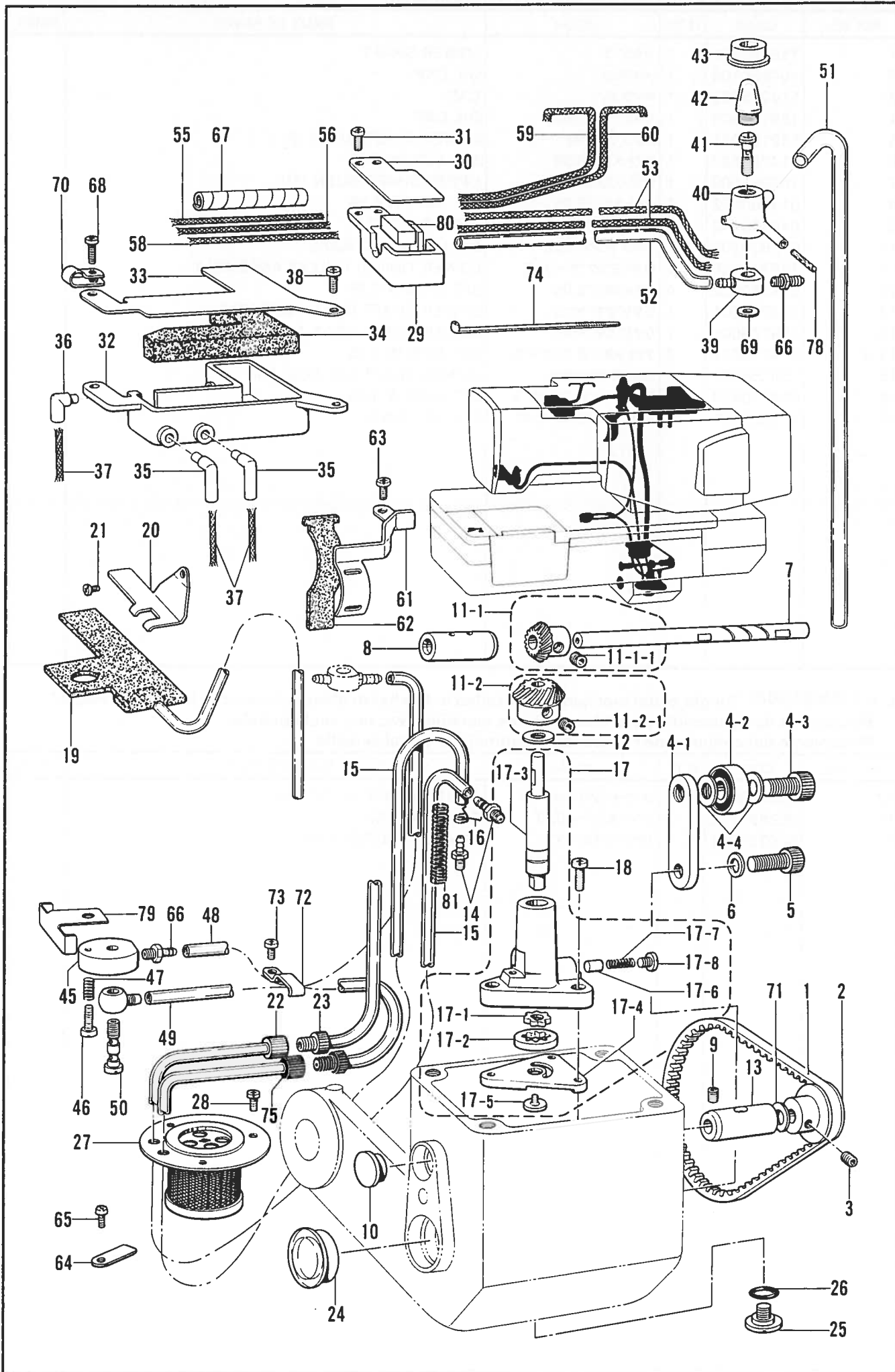

R. 給油潤滑関係 / Lubrication / Schmierung /
Lubrification / Lubricación

REF NO.	CODE	Q'TY	ヒンメイ	NAME OF PARTS	RMKS
1	159170000	1	ポンプヘルム	PUMP BELT	
2	159171000	1	ポンププーリTR	PUMP PULLEY (TR)	
3	014760622	2	アタメネジ"5.95	SET SCREW 5.95	
4	159172001	1	Pテンションプーリクミ	PUMP TENSION PULLEY ASSEMBLY	
4-1	159173001	1	Pテンションプーリタ"イ	PUMP TENSION PULLEY BASE	
4-2	072600040	1	タマシ"クウケ6000DD	BALL BEARING 6000DD	
4-3	018101622	1	アナホルト 10X16	BOLT 10X16	
4-4	025100132	1	ヒラサ"カ"ネシヨウ10	PLAIN WASHER 10	
5	018081422	1	アナホルト8X14	BOLT 8X14	
6	025080232	1	ヒラサ"カ"ネチユウ8	PLAIN WASHER 8	
7	159174001	1	ポンププーリシ"ク	PUMP PULLEY SHAFT	
8	142766001	1	ポンププーリシ"クメタル	PUMP PULLEY SHAFT BUSH	
9	014760622	1	アタメネジ"5.95	SET SCREW 5.95	
10	150756009	1	メクラセン	OIL CAP	
11-1	143915001	1	へ"へ"ルキ"ヤDクミ	BEVEL GEAR (D) ASSEMBLY	
11-1-1	014770622	2	アタメネジ"6.35クホ"ミ	SET SCREW 6.35	
11-2	180515001	1	へ"へ"ルキ"ヤDクミ	BEVEL GEAR (D) ASSEMBLY	
11-2-1	014770622	2	アタメネジ"6.35クホ"ミ	SET SCREW 6.35	
12	110367001	1	サ"カ"ネ	WASHER	
13	S01047001	1	ポンプメタルF	PUMP BUSH (F)	
14	142359001	2	オイルクチ	OIL FEEDING PIPE	
15	159175000	2	ヒ"ニルチューブ"	OIL TUBE	
16	S07876001	1	チューブ"ストツハ"	TUBE STOPPER	
17	148761001	1	ポンプクミ	PUMP ASSEMBLY	
17-1	141643000	1	オイルポンプ"インナーロータ	OIL PUMP INNER ROTOR	
17-2	141642000	1	オイルポンプ"アウトロータ	OIL PUMP OUTER ROTOR	
17-3	148469001	1	ポンプシ"ク	PUMP SHAFT	
17-4	148470001	1	ポンプフタ	PUMP CAP PLATE	
17-5	145465001	1	シメネジ"3.57L	SCREW 3.57 (L)	
17-6	148471001	1	プランジ"ヤー	PLUNGER	
17-7	144876001	1	プランジ"ヤーハ"ネ	PLUNGER SPRING	
17-8	112467002	1	シメネジ"6.35	SCREW 6.35	
18	062711212	3	ナヘ"コ476-32X12	SCREW 476X12	
19	S19963101	1	スイアケ"チューブ"クミ	ABSORBING TUBE ASSEMBLY	
20	159181001	1	スイアケ"フェルトササエ	FELT SUPPORT	
21	062670612	1	ナヘ"コ357-40X6	SCREW 357X6	
22	142750002	1	ツキ"テナット	NUT	
23	142748002	1	ヒ"ニルチューブ"ツキ"テ	OIL TUBE JOINT	
24	152948001	1	オイルホ"ットマト"	OIL GAUGE WINDOW	
25	110641002	1	タ"ンネジ"9.52	STUD SCREW 9.52	
26	109203001	1	Oリング"	O RING	
27	159182101	1	フィルタ"クミ	OIL FILTER ASSEMBLY	
28	062680812	3	ナヘ"コ437-40X8	SCREW 437X8	
29	159187000	1	トウジンヘ"ースA	FELT BASE (A)	
30	159188001	1	トウジンヘ"ースAフタ	WICK BASE (A) COVER	
31	062680812	2	ナヘ"コ437-40X8	SCREW 437X8	
32	159189000	1	トウジンヘ"ースB	WICK BASE (B)	
33	159190001	1	トウジンヘ"ースBフタ	WICK BASE (B) COVER	
34	159191000	1	トウジンヘ"ースBフェルト	FELT	
35	159192000	2	オイルパイプ"A	OIL PIPE (A)	
36	159193000	1	オイルパイプ"B	OIL PIPE (B)	
37	159601000	3	クミヒモ4X4	WICK 4X4	
38	062680812	1	ナヘ"コ437-40X8	SCREW 437X8	
39	159194000	1	キユウユクチ	OIL TUBE JOINT	
40	159195000	1	オイルターミナル	OIL TERMINAL	
41	159199001	1	オイルフキタ"シクチ	OIL FLOWING SCREW	
42	143713101	1	オイルキャツプ"	OIL CAP	
43	159201009	1	アプ"ラマト"ササエ	OIL WINDOW HOLDER	
45	159203100	1	キユウユチヨウセツタイ	OIL ADJUST BASE	
46	062681412	1	ナヘ"コ437-40X14	SCREW 437X14	
47	159204001	1	チヨウセツネシ"ハ"ネ	SPRING	
48	S19965001	1	キユウユチチューブ"クミA	OIL TUBE ASSEMBLY (A)	

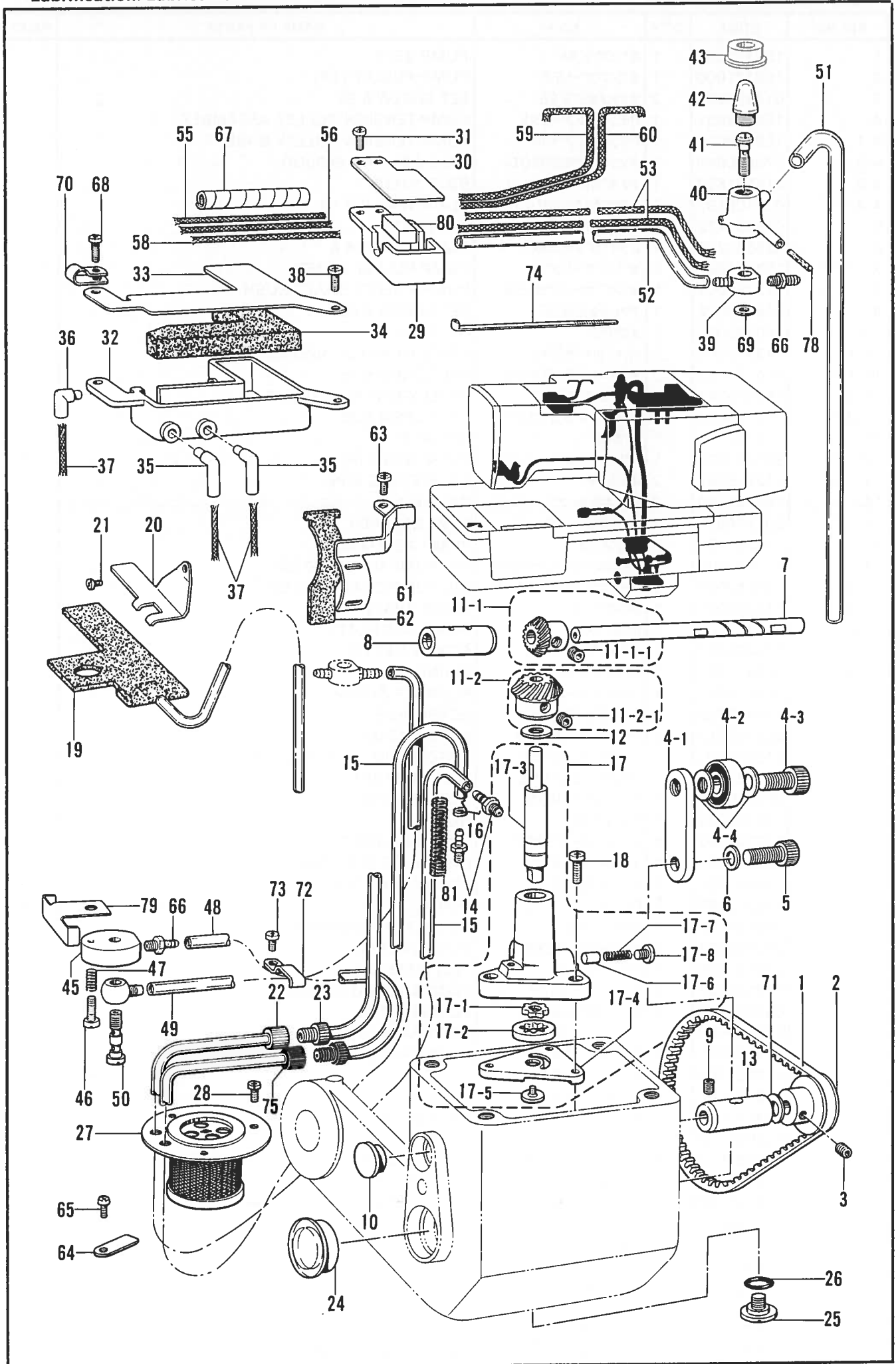

R. 給油潤滑関係 / Lubrication / Schmierung /
Lubrification / Lubricación

REF.NO	CODE	Q'TY	ヒンメイ	NAME OF PARTS	RMKS
49	159207101	1	キユウチューブ"クミB	OIL TUBE ASSEMBLY (B)	
50	112364001	1	ハイユパイプ"ツキ"テネシ"	OIL FEEDING PIPE JOINT SCREW	
51	159209000	1	ビニールチューブ"	OIL TUBE	
52	141650000	1	ビニールチューブ"	OIL TUBE	
53	159564000	1	クミヒモ2.5X500	WICK (L=500)	
55	159565000	1	クミヒモ2.5X150	WICK (L=150)	
56	159566000	1	クミヒモ3X450	WICK (L=450)	
58	159567000	1	クミヒモ3X180	WICK (L=180)	
59	159568000	1	クミヒモ2.5X100	WICK (L=100)	
60	159569000	1	クミヒモ2.5X150	WICK (L=150)	
61	159213001	1	ウオームフェルトササエ	WORM FELT SUPPORT	
62	159214000	1	ウオームフェルト	WORM FELT	
63	062680612	2	ナヘ"コ437-40X6	SCREW 437X6	
64	152937001	1	サ"カ"ネ	WASHER	
65	062670512	1	ナヘ"コ357-40X5	SCREW 357X5	
66	142359001	2	オイルクチ	OIL FEEDING PIPE	
67	159909000	1	スパイラルチューブ"	SPIRAL TUBE	
68	062681012	1	ナヘ"コ437-40X10	SCREW 437X10	
69	112348001	2	ハ"ツキン	PACKING	
70	149547000	1	コート"オサエ	CORD HOLDER 4N	
71	107153001	1	サ"カ"ネ	WASHER	
72	142268001	1	コート"オサエL	CORD HOLDER (L)	
73	062670612	1	ナヘ"コ357-40X6	SCREW 357X6	
74	149799000	4	タイラツフ"S	BEAD BAND (S)	
75	142750001	1	ツキ"テナツト	NUT	
78	145751001	1	フェルト	FELT	
79	S09566001	1	オイルカバー	OIL COVER	
80	S17062000	1	ヘ"ツト"タ"イクツシヨ	BED BASE CUSHION	
81	144086001	1	オサエホ"ウアケ"ハ"ネ	SPRING	

S. 糸通シ関係 / Threading mechanism / FadenführungsVorrichtung /
 Mécanisme de l'enfilage / Mecanismo del enhebrado

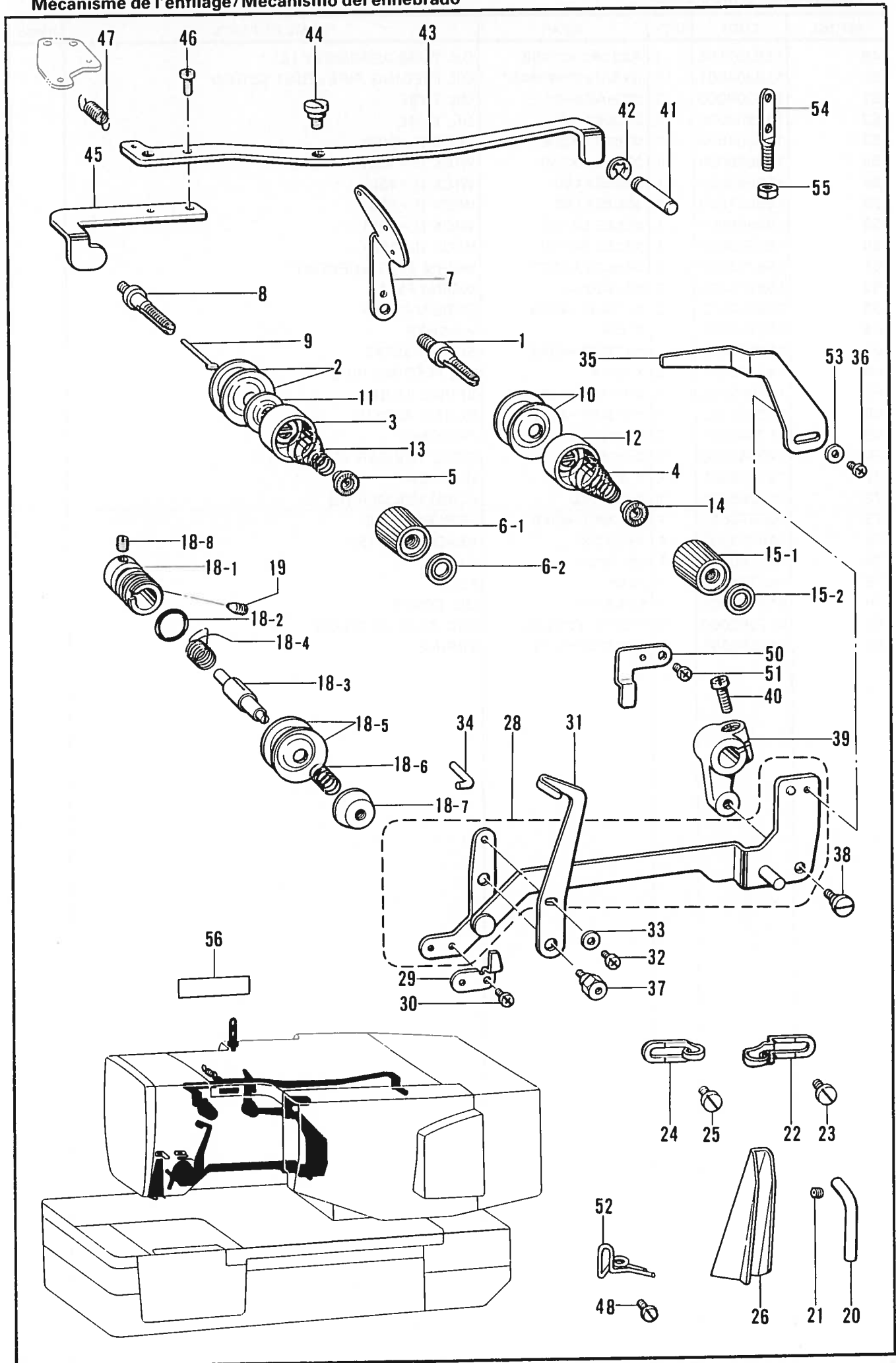

S. 糸通シ関係 / Threading mechanism / Fadenführungsrichtung /
 Mécanisme de l'enfilage / Mecanismo del enhebrado

REF. NO.	CODE	Q'TY	ヒンメイ	NAME OF PARTS	RMKS
1	110820101	1	イトチヨウシホ"ウ	TENSION STUD	
2	145446001	2	イトチヨウシサラ	TENSION DISC	
3	144103009	1	イトチヨウシサラオサエ	TENSION DISC WASHER	
4	144104001	1	ハリイトチヨウシハ"ネ	THREAD TENSION ADJUST SPRING	
5	144105000	1	チヨウシハ"ネウエサ"カ"ネ	SPRING WASHER	
6	S19869003	1	イトチヨウシナツクミ(アカ)	THREAD TENSION CONTROL NUT ASSEMBLY (RED)	
6-1	149566009	1	イトチヨウシナツト	TENSION NUT	
6-2	155697003	1	キヨウジ"ヤクハ"ン	TENSION INDICATING PLATE	
7	159218001	1	ミツメイトカケ	THREAD RETAINER	
8	159219101	1	フクイトチヨウシホ"ウ	SUB TENSION STUD	
9	159220101	1	イトユルメヒ"ン	PIN	
10	145446001	2	イトチヨウシサラ	TENSION DISC	
11	159805001	1	イトチヨウシサラオサエ	TENSION DISC PRESSER	
12	144103009	1	イトチヨウシサラオサエ	TENSION DISC WASHER	
13	159221001	1	イトチヨウシハ"ネ	TENSION SPRING	
14	144105000	1	チヨウシハ"ネウエサ"カ"ネ	SPRING WASHER	
15	S19869002	1	イトチヨウシナツクミ (ミト"リ)	THREAD TENSION CONTROL NUT ASSEMBLY (GREEN)	
15-1	149566009	1	イトチヨウシナツト	TENSION NUT	
15-2	155697002	1	キヨウジ"ヤクハ"ン	TENSION INDICATING PLATE	
18	159623001	1	イトチヨウシタ"イクミ	TENSION BRACKET ASSEMBLY	
18-1	144741001	1	イトチヨウシホ"ウタ"イ	THREAD TENSION BRACKET	
18-2	114294001	1	O"リング"	O RING	
18-3	159222001	1	イトトリハ"ネチヨウセツホ"ウ	TENSION STUD	
18-4	145519001	1	イトトリハ"ネ	SPRING	
18-5	145446001	2	イトチヨウシサラ	TENSION DISC	
18-6	159223001	1	サブ"イトチヨウシハ"ネ	SUB TENSION SPRING	
18-7	159331001	1	イトチヨウシサラナツト	TENSION DISC NUT	
18-8	100402004	1	トメネジ"3.57	SET SCREW 3.57	
19	103950003	1	トメネジ"5.95	SET SCREW 5.95	
20	159224001	1	アームイトカケ	ARM THREAD GUIDE	
21	014680622	1	アナトメネジ"4.37クホ"ミ	SET SCREW 4.37	
22	S19961001	1	アームイトアンナイ	ARM THREAD GUIDE	
23	112751002	1	シメネジ"3.57	SCREW 3.57	
24	113316001	1	アームイトアンナイ	ARM THREAD GUIDE	
25	112751002	1	シメネジ"3.57	SCREW 3.57	
26	159546101	1	イトトオシイタ	THREAD GUIDE PLATE	
28	159228001	1	イトトリレハ"ークミ	THREAD TAKE-UP LEVER ASSEMBLY	
29	159234001	1	チヨウシサラワリツメ	TENSION DISC CLAW	
30	062670512	2	ナヘ"コ357-40X5	SCREW 357X5	
31	159235101	1	ウフイトユルメ	UPPER THREAD RELEASER	
32	062680512	1	ナヘ"コ437-40X5	SCREW 437X5	
33	025680132	1	ヒラサ"カ"ネシヨウ4.37	PLAIN WASHER 4.37	
34	159236001	1	イトトリヒ"ン	PIN	
35	159237001	1	シユチヨウシユルメイタ	MAIN TENSION RELEASE PLATE	
36	062680612	1	ナヘ"コ437-40X6	SCREW 437X6	
37	S01558001	1	スヘ"ースタ"ンネジ"	STUD SCREW	
38	159908001	1	タ"ンネジ"4.37	STUD SCREW 4.37	
39	159239001	1	イトトリレハ"ーウテ"	THREAD TAKE-UP LEVER ARM	
40	062761612	1	ナヘ"コ595-28X16	SCREW 595X16	
41	159240001	1	イトユルメサト"ウヒ"ン	PIN	
42	048040342	1	トメフE4	STOP RING E4	
43	159241001	1	イトユルメテコ	TENSION RELEASE LEVER	
44	144526001	1	タ"ンネジ"4.37	STUD SCREW 4.37	
45	159242001	1	イトユルメテコS	TENSION RELEASE LEVER (S)	
46	062680812	2	ナヘ"コ437-40X8	SCREW 437X8	
47	159243001	1	イトユルメテコハ"ネ	SPRING	
48	112751002	1	シメネジ"3.57	SCREW 3.57	
50	159226001	1	シユチヨウシユルメアンナイ	MAIN TENSION RELEASE GUIDE	
51	062680612	1	ナヘ"コ437-40X6	SCREW 437X6	
52	159917101	1	アームイトアンナイシタ	ARM THREAD GUIDE (LOWER)	

S. 糸通シ関係 / Threading mechanism / FadenführungsVorrichtung /
 Mécanisme de l'enfilage / Mecanismo del enhebrado

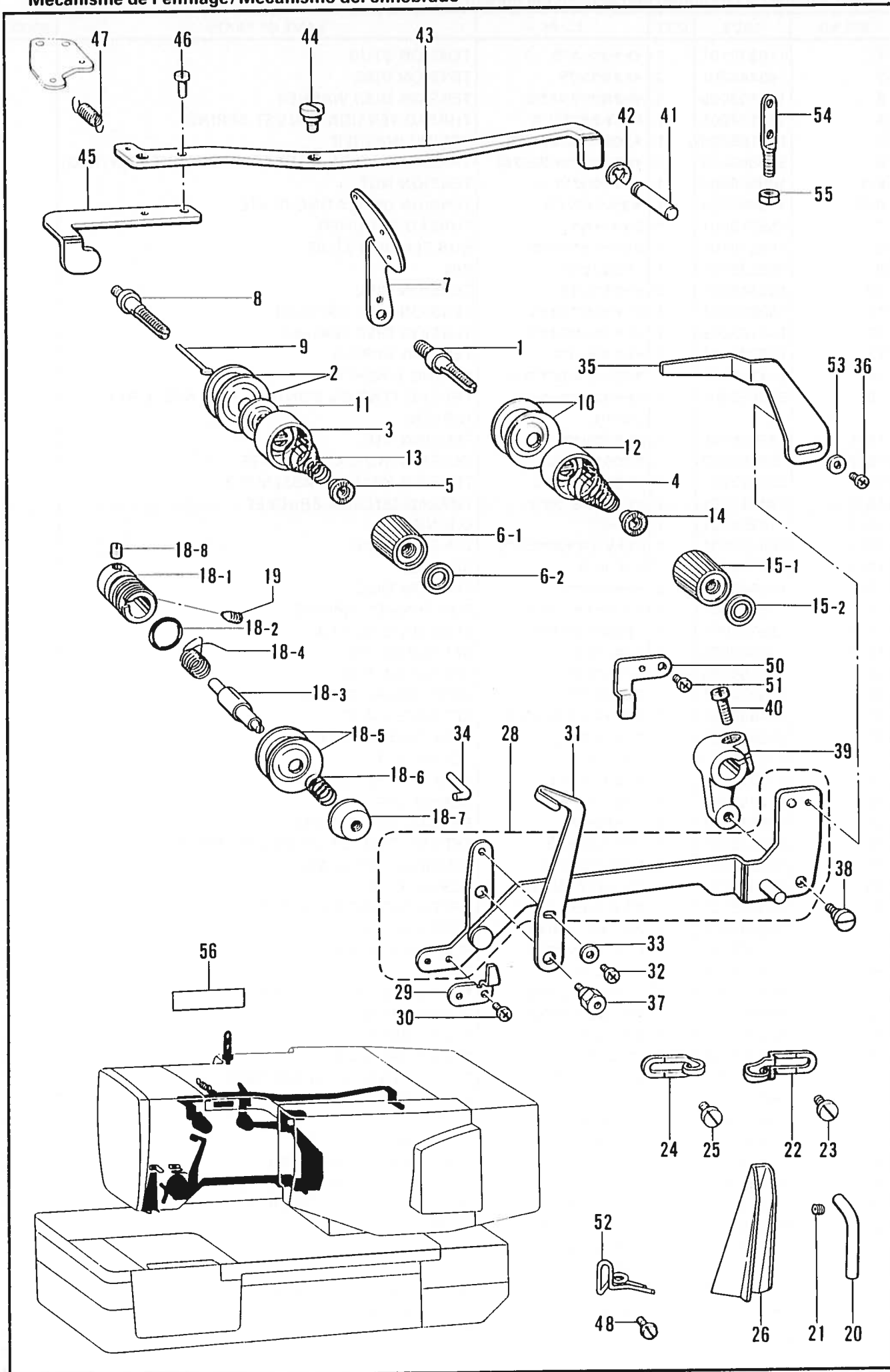

S. 糸通シ関係 / Threading mechanism / Fadenführungsrichtung /
 Mécanisme de l'enfilage / Mecanismo del enhebrado

REF. NO.	CODE	Q'TY	ヒンメイ	NAME OF PARTS	RMKS
53	025680132	1	ヒラサ"ガ"ネシヨウ4.37	PLAIN WASHER 4.37	
54	141590001	1	イトトオシホ"ウ	THREADING BAR (U)	
55	150553003	1	ナツト5.95	NUT 5.95	
56	S13713001	1	チヨウシツマミセツメイイタ	DIAGRAM	

T. 糸巻装置 / Bobbin winder / Spuler /
 Mécanisme du bobineur / Mecanismo del devanador de la canilla

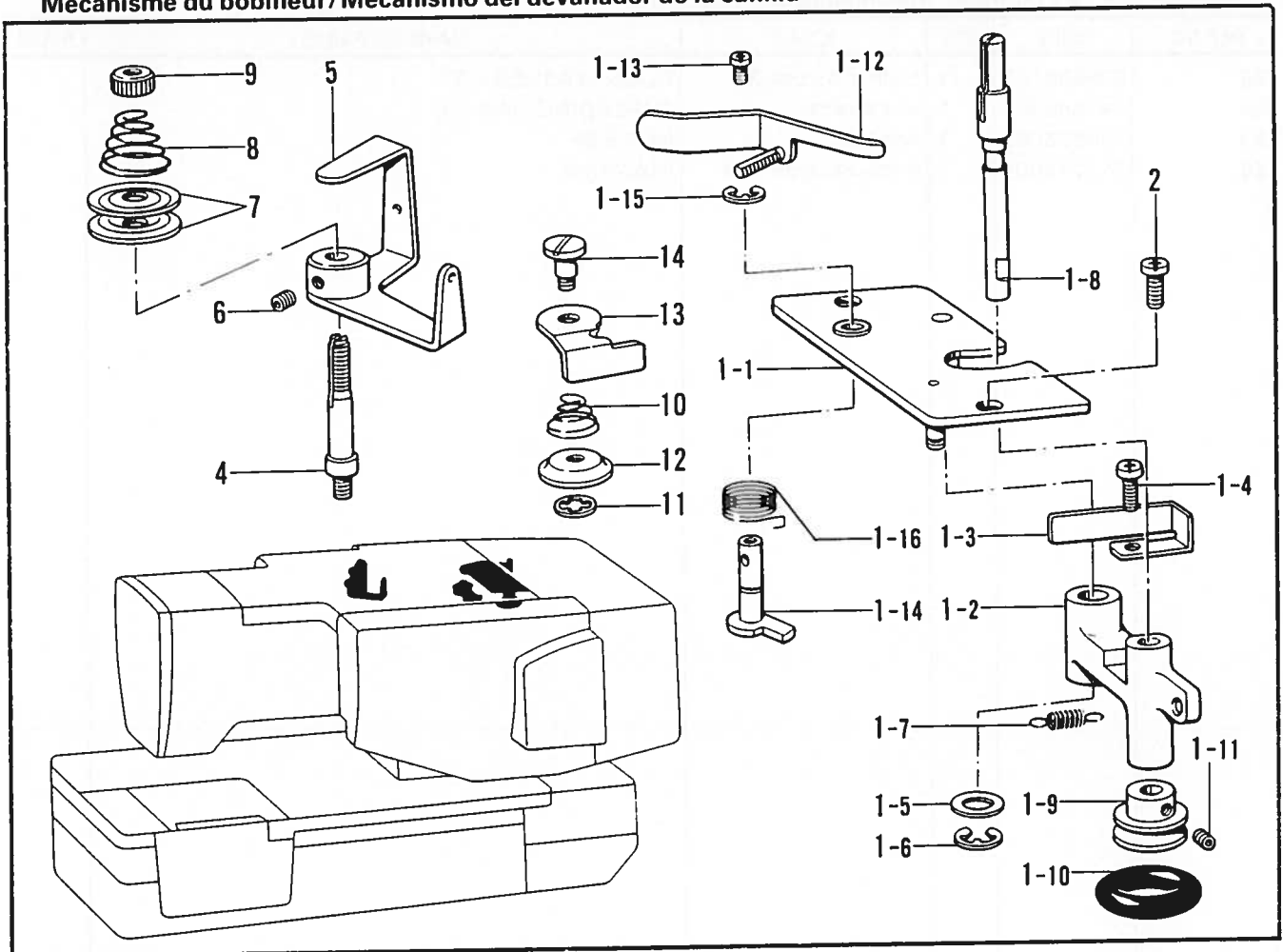

U. 減速関係 / Power transmitter mechanism / Kraftübertragungsvorrichtung /
 Mécanisme du transmetteur / Mecanismo del transmisor de potencia

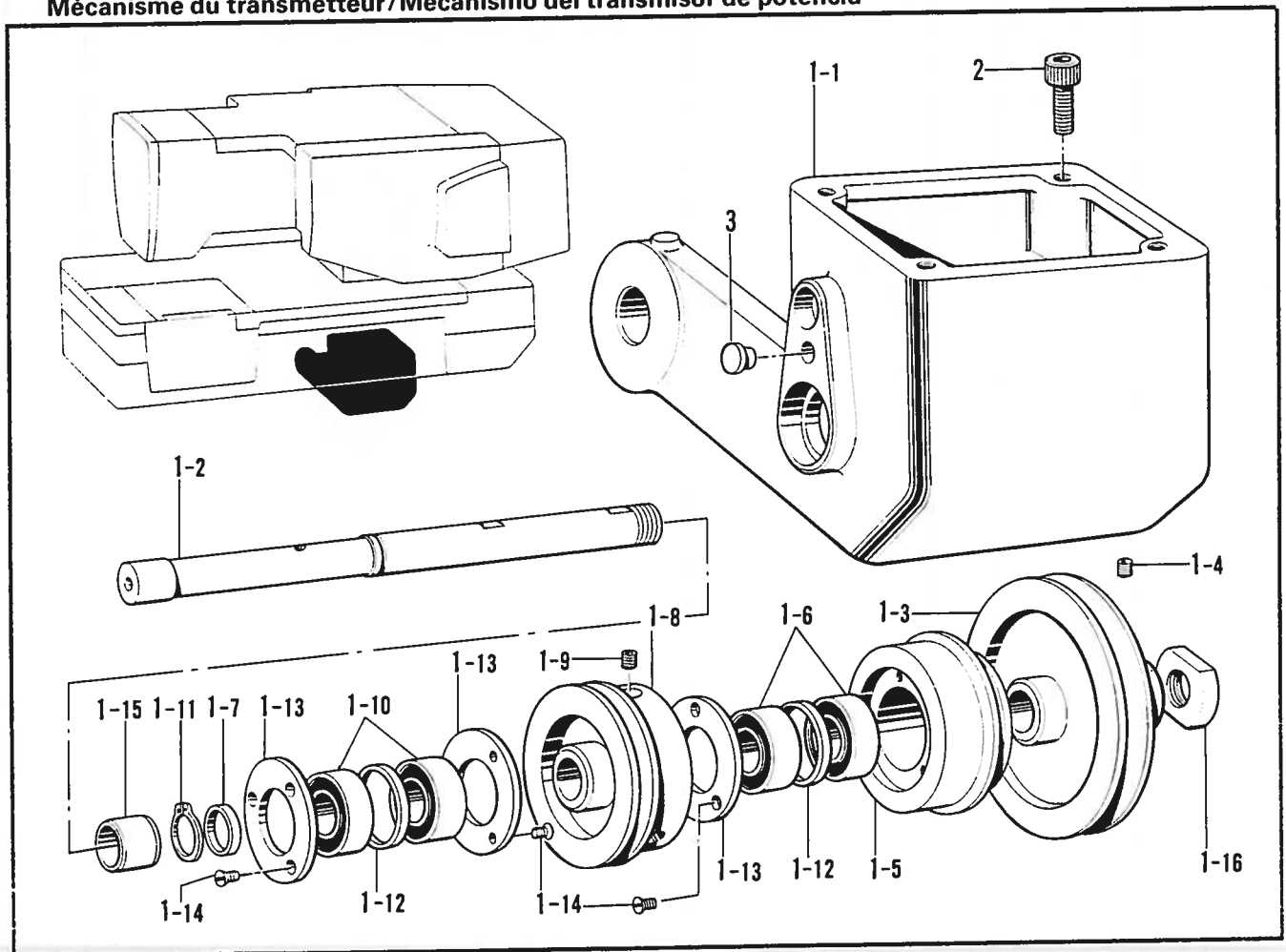

T. 糸巻装置 / Bobbin winder / Spuler /

Mécanisme du bobineur / Mecanismo del devanador de la canilla

REF.NO.	CODE	Q'TY	ヒンメイ	NAME OF PARTS	RMKS
1	S01287009	1	イトマキクミ	BOBBIN WINDER ASSEMBLY	
1-1	S01288003	1	イトマキト"タ"イクミ	BOBBIN WINDER BRACKET ASSEMBLY	
1-2	S01290001	1	イトマキウテ"	BOBBIN ARM WINDER FRAME	
1-3	S01292001	1	イトマキイタハ"ネ	PLATE SPRING	
1-4	062680812	1	ナヘ"コ437-40X8	SCREW 437X8	
1-5	025080132	1	ヒラサ"カ"ネシヨウ8	PLAIN WASHER 8	
1-6	048060342	1	トメフE6	STOP RING E6	
1-7	S01294001	1	イトマキウテ"ハ"ネ	SPRING	
1-8	159252001	1	イトマキシ"ク	BOBBIN WINDER SHAFT	
1-9	154528001	1	イトマキクルマ	BOBBIN WINDER WHEEL	
1-10	120448001	1	ゴムワ	RUBBER RING	
1-11	014680622	2	アナトメネシ"4.37クホ"ミ	SET SCREW 4.37	
1-12	159253001	1	ホ"ビ"ンオサエ	BOBBIN PRESSER	
1-13	062670612	1	ナヘ"コ357-40X6	SCREW 357X6	
1-14	S01291001	1	イトマキカムシ"ク	THREAD WINDER CAM SHAFT	
1-15	048050342	1	トメフE5	STOP RING E5	
1-16	S01293001	1	イトマキカムシ"クハ"ネ	SPRING	
2	062710812	2	ナヘ"コ476-32X8	SCREW 476X8	
4	159256001	1	イトマキチヨウシホ"ウ	BOBBIN WINDER THREAD TENSION STUD	
5	159257001	1	イトマキイトアンナイ	BOBBIN WINDER THREAD GUIDE	
6	014680622	1	アナトメネシ"4.37クホ"ミ	SET SCREW 4.37	
7	145446001	2	イトチヨウシサラ	TENSION DISC	
8	115188001	1	シユイトチヨウシハ"ネ	TENSION SPRING	
9	100136001	1	イトチヨウシナツト	TENSION NUT	
10	144505000	1	イトアンナイハ"ネ	SPRING	
11	146200001	1	トメフCS4	STOP RING CS4	
12	146199001	1	イトツカミサラ	THREAD CLAMP DISC	
13	146198001	1	イトツカミメス	THREAD CLAMP KNIFE	
14	118764002	1	タ"ンネシ"4.37	STUD SCREW 4.37	

U. 減速関係 / Power transmitter mechanism / Kraftübertragungsvorrichtung /

Mécanisme du transmetteur / Mecanismo del transmisor de potencia

REF.NO.	CODE	Q'TY	ヒンメイ	NAME OF PARTS	RMKS
1	159550109	1	トランスミツタタ"イクミ	TRANSMITTER BASE ASSEMBLY	
1-1	S07849009	1	トランスミツタタ"イ	TRANSMITTER BASE	
1-2	S07850001	1	トランスミツタシ"ク	TRANSMITTER SHAFT	
1-3	158984101	1	テイソクVプ"ーリ	SLOW SPEED (V) PULLEY	
1-4	014760622	2	アナトメネシ"5.95	SET SCREW 5.95	
1-5	S07851001	1	コウソクプ"ーリ	HIGH SPEED PULLEY	
1-6	072600360	2	タマシ"クウケ6003VV	BALL BEARING 6003VV	
1-7	158986101	1	サ"ガ"ネ	WASHER	
1-8	158987101	1	テイソクプ"ーリ	SLOW SPEED PULLEY	
1-9	014760622	2	アナトメネシ"5.95	SET SCREW 5.95	
1-10	072600360	2	タマシ"クウケ6003VV	BALL BEARING 6003VV	
1-11	048170142	1	トメフシ"クヨウC17	STOP RING C17	
1-12	158981101	2	ハ"アリング"カンサ"	BEARING COLLAR	
1-13	141276001	3	タマシ"クウケフタS	CAP (S)	
1-14	102843004	9	サラネシ"3.57	SCREW 3.57	
1-15	S07852000	1	ト"ライメツトフ"ツシユ	DRY MET BUSH	
1-16	602344001	1	チャツクナツト	CHUCK NUT	
2	018082022	4	アナホ"ルト8X20	BOLT 8X20	
3	104450109	1	メクラセシ	OIL CAP	

V. 上糸切り関係 / Upper thread trimmer mechanism / Oberer Fadenabschneider /
 Mécanisme de la coupe-fil supérieur / Mecanismo de la recortadura de hilos superior

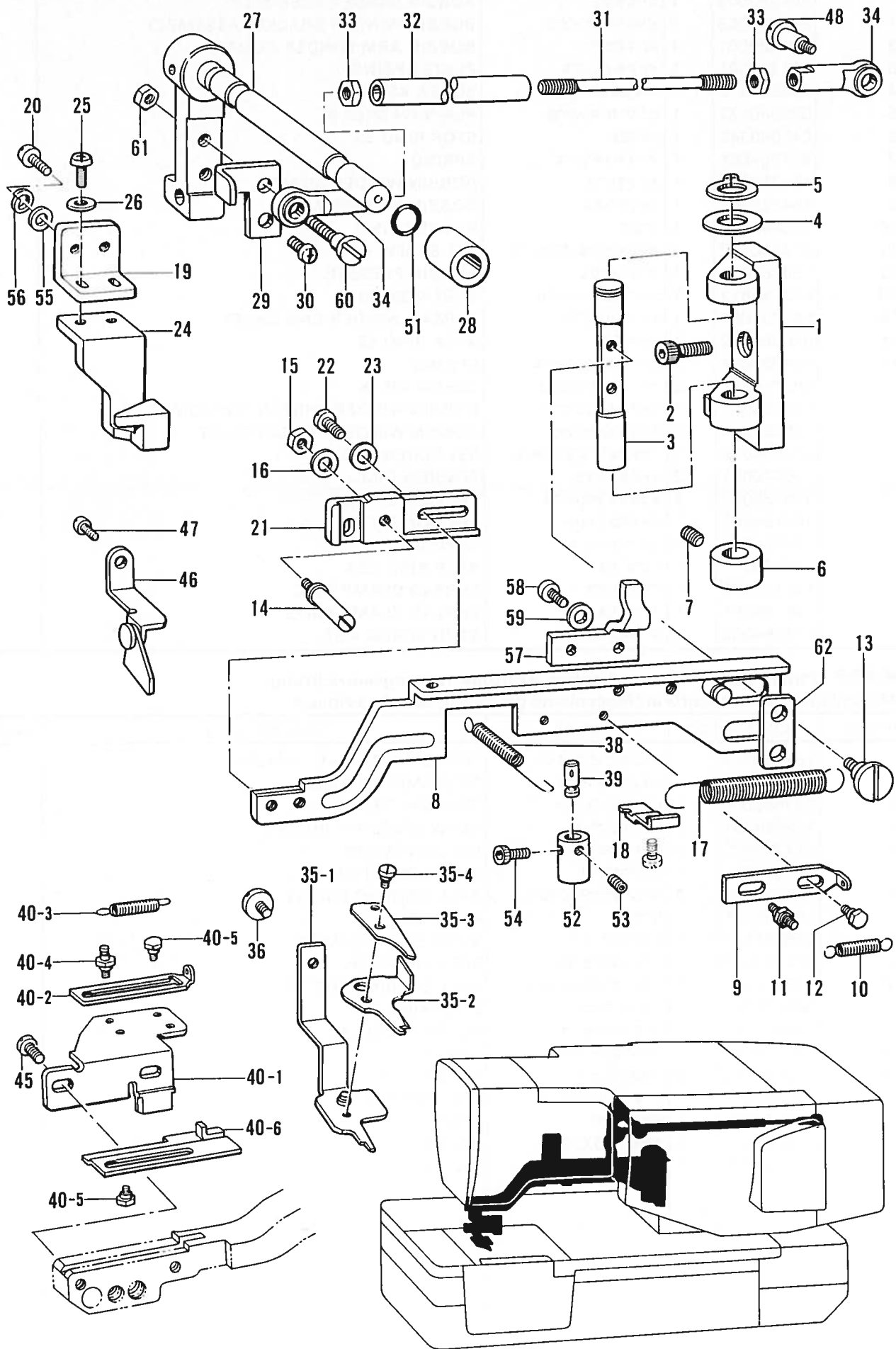

V. 上糸切り関係 / Upper thread trimmer mechanism / Oberer Fadenabschneider /
 Mécanisme de la coupe-fil supérieur / Mecanismo de la recortadura de hilos superior

REF.NO.	CODE	Q'TY	ヒンメイ	NAME OF PARTS	RMKS
1	S19829001	1	ウフイキリシテント"タ"イ	UPPER THREAD TRIMMER LEVER BRACKET	
2	018061622	2	アナホ"ルト6X16	BOLT 6X16	
3	159336001	1	ウフイキリシテシ"ク	UPPER THREAD TRIMMER FULCRUM SHAFT	
4	115007001	1	サ"カ"ネ	WASHER	
5	048120142	1	トメフシ"クヨウC12	STOP RING C12	
6	117671002	1	セツトカラー	SET COLLAR	
7	014770622	2	アナトメネシ"6.35クホ"ミ	SET SCREW 6.35	
8	S19835001	1	ウフイキリレハ"ークミ	UPPER THREAD TRIMMER LEVER ASSEMBLY	
9	159341001	1	ハサミハス"シクラツチイタ	UPPER THREAD TRIMMER CLUTCH PLATE	
10	159111001	1	Cクラツチアンナイハ"ネ	SPRING	
11	159948001	1	ハ"ネカケ	SPRING HOOK	
12	159113001	1	タ"ンネシ"3.18	STUD SCREW 3.18	
13	S19817001	2	タ"ンネシ"5.95	STUD SCREW 5.95	
14	159343001	1	ハサミササエシ"ク	UPPER THREAD TRIMMER SUPPORT STUD	
15	021680202	1	ナツト2シユ4.37	NUT 4.37	
16	025680132	1	ヒラサ"カ"ネシユウ4.37	PLAIN WASHER 4.37	
17	159344001	1	ハサミモト"シハ"ネ	SPRING	
18	159345001	1	ハ"ネカケ	SPRING HOOK	
19	159346101	1	ハサミハス"シアンナイ	UPPER THREAD TRIMMER CLUTCH GUIDE	
20	062681412	2	ナヘ"コ437-40X14	SCREW 437X14	
21	159017001	1	ウフイキリレハ"ーB	UPPER THREAD TRIMMER LEVER (B)	
22	062680612	2	ナヘ"コ437-40X6	SCREW 437X6	
23	025680232	2	ヒラサ"カ"ネチユウ4.37	PLAIN WASHER 4.37	
24	159348101	1	ハサミハス"シカム	UPPER THREAD TRIMMER DETACH CAM	
25	153057002	2	オクリイタシメネシ"	SCREW	
26	025680232	2	ヒラサ"カ"ネチユウ4.37	PLAIN WASHER 4.37	
27	S19833001	1	ハサミオシレハ"ークミ	UPPER THREAD TRIMMER PUSHING LEVER	
28	159262000	1	オシレハ"ーシ"クメタル	THREAD TRIMMER PUSHING LEVER BUSH	
29	S19834001	1	ハサミクト"ウツメ	TRIMMER DRIVING CLAW	
30	062761012	1	ナヘ"コ595-28X10	SCREW 595X10	
31	S19821001	1	ウフイキリレンカン	UPPER THREAD TRIMMER CONNECTOR	
32	159356001	1	ウフイキリレンカンハ"イフ	UPPER THREAD TRIMMER ROD PIPE	
33	106588003	2	ナツト5.95	NUT 5.95	
34	141492001	2	タマツキ"テクミ	JOINT ASSEMBLY	
35	S19824001	1	ハサミクミ	UPPER THREAD TRIMMER ASSEMBLY	
35-1	S19820001	1	ハサミDクミ	UPPER THREAD TRIMMER (D)ASSEMBLY	
35-2	S19822001	1	ハサミM	UPPER THREAD TRIMMER (M)	
35-3	S19823001	1	ハサミU	UPPER THREAD TRIMMER (U)	
35-4	141514001	1	ハサミタ"ンネシ"	STUD SCREW	
36	115503001	1	シメネシ"4.37	SCREW 4.37	
38	159378001	1	ハサミサト"ウハ"ネ	SPRING	
39	159379001	1	ミソ"ツキヒンBX6X18	DOWEL PIN BX6X18	
40	S19844001	1	ハサミアンナイクミ	UPPER THREAD TRIMMER GUIDE ASSEMBLY	
40-1	S19825001	1	ハサミアンナイ	UPPER THREAD TRIMMER GUIDE	
40-2	159381001	1	ハサミアンセ"ンイタ	UPPER THREAD TRIMMER SAFETY PLATE	
40-3	159111001	1	Cクラツチアンナイハ"ネ	SPRING	
40-4	159948001	1	ハ"ネカケ	SPRING HOOK	
40-5	159113001	3	タ"ンネシ"3.18	STUD SCREW 3.18	
40-6	S19956001	1	ハサミアンセ"ンイタD	UPPER THREAD TRIMMER SAFETY PLATE (D)	
45	062681012	2	ナヘ"コ437-40X10	SCREW 437X10	
46	159554001	1	ハサミニカ"シイタササエクミ	THREAD TRIMMER GUARD SUPPORT ASSEMBLY	
47	062760812	1	ナヘ"コ595-28X8	SCREW 595X8	
48	141494001	1	タマツキ"テタ"ンネシ"	STUD SCREW	
51	081006670	1	Oリング"PW6	O RING PW6	
52	S01559001	1	セツト"タ"イ	SET STUD	
53	014400522	1	アナクホ"ミ4X5	SET SCREW 4X5	
54	018401022	1	アナホ"ルト4X10	BOLT 4X10	
55	025680232	2	ヒラサ"カ"ネチユウ4.37	PLAIN WASHER 4.37	
56	028680242	2	ハ"ネサ"カ"ネ2-4.37	SPRING WASHER 2-4.37	
57	S19827001	1	ウフイキリレハ"ーササエ	UPPER THREAD TRIMMER LEVER SUPPORT	
58	062680812	2	ナヘ"コ437-40X8	SCREW 437X8	
59	025680232	2	ヒラサ"カ"ネチユウ4.37	PLAIN WASHER 4.37	

V. 上糸切り関係 / Upper thread trimmer mechanism / Oberer Fadenabschneider /
 Mécanisme de la coupe-fil supérieur / Mecanismo de la recortadura de hilos superior

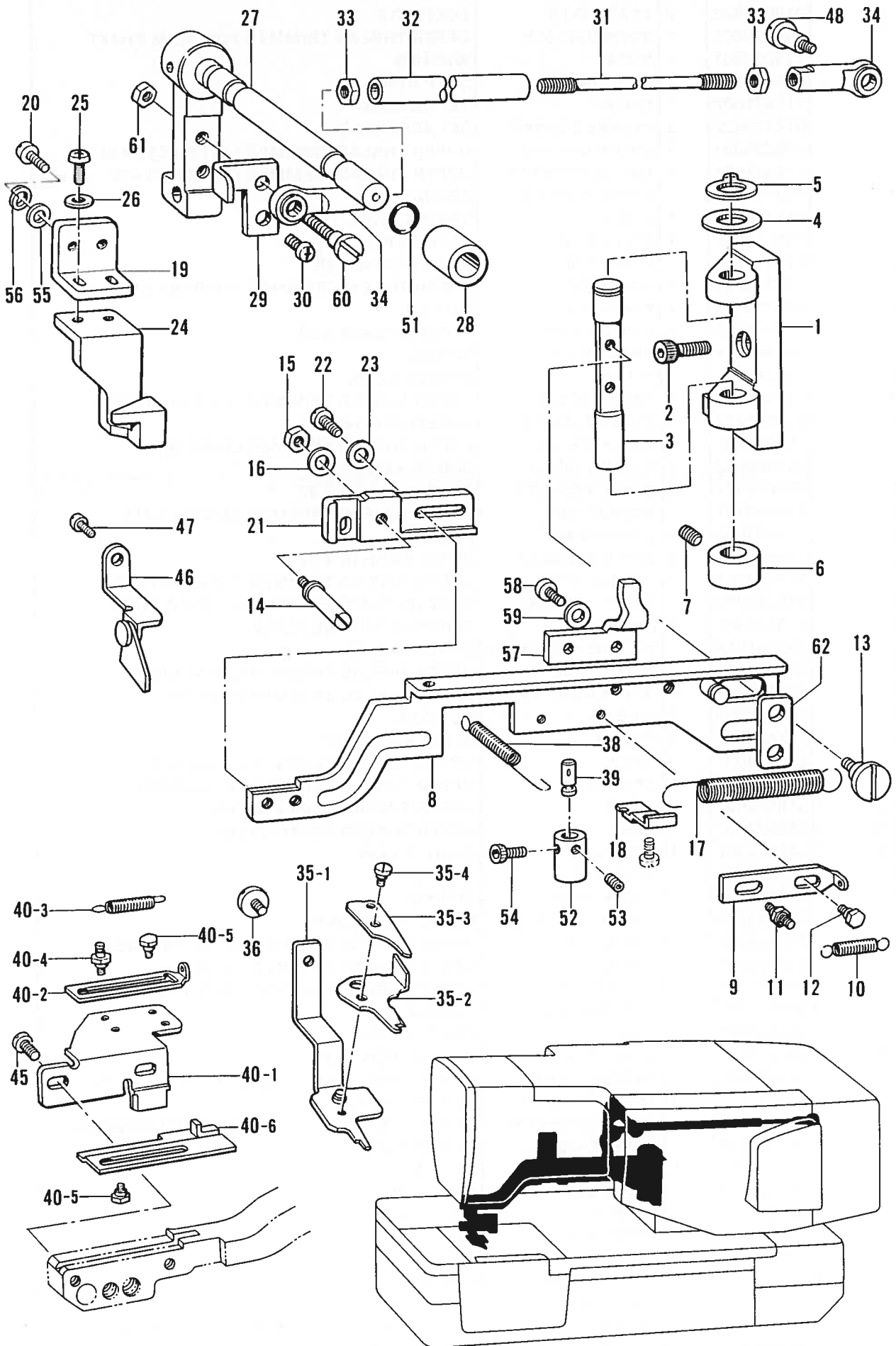

V. 上糸切り関係/Upper thread trimmer mechanism/Oberer Fadenabschneider/
 Mécanisme de la coupe-fil supérieur/Mecanismo de la recortadura de hilos superior

REF.NO.	CODE	Q'TY	品名	NAME OF PARTS	RMKS
60	S20113001	1	タマツキ"テタ"ンネジ	STUD SCREW	
61	150553001	1	ナット5.95	NUT 5.95	
62	S19818001	1	ウワイトキリルハ"ーサ"ガ"ネ	WASHER	

W. 下糸切り関係 / Lower thread trimmer mechanism / Unterer Fadenabschneider /
 Mécanisme de la coupe-fil inférieur / Mecanismo de la recortadura de hilos inferior

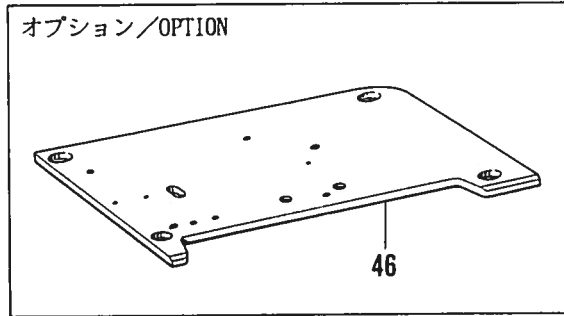
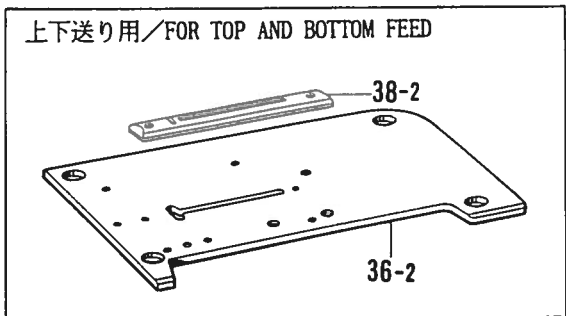
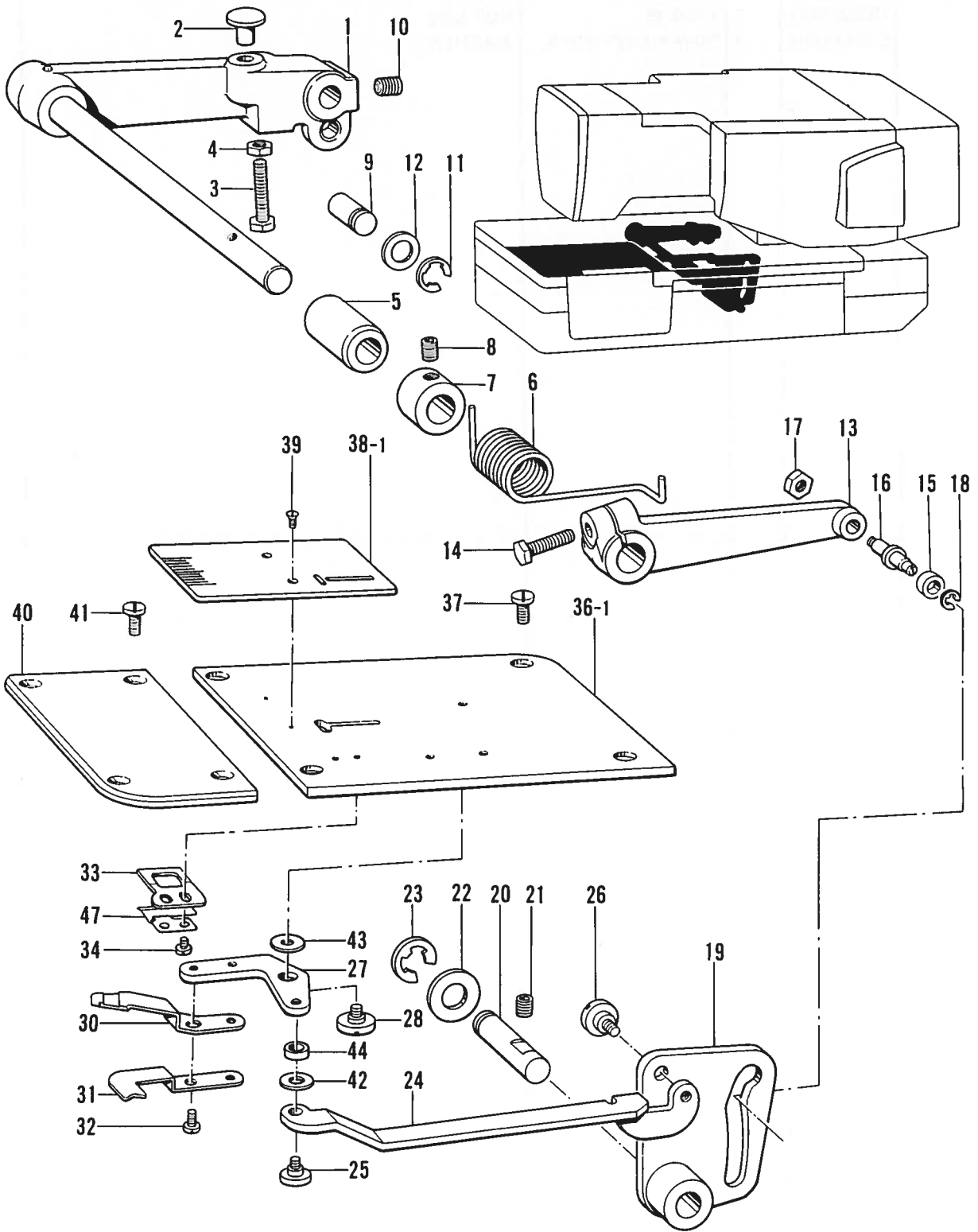

W. 下糸切り関係 / Lower thread trimmer mechanism / Unterer Fadenabschneider /
 Mécanisme de la coupe-fil inférieur / Mecanismo de la recortadura de hilos inferior

REF.NO.	CODE	Q'TY	ヒンメイ	NAME OF PARTS	RMKS
1	159259201	1	シタイトキリレハークミ	LOWER THREAD TRIMMER LEVER ASSEMBLY	
2	S19810009	1	シタイトキリレハークツシヨ	LOWER THREAD TRIMMER LEVER CUSHION	
3	017762202	1	ボルト5.95X22	BOLT 5.95X22	
4	106588003	1	ナット5.95	NUT 5.95	
5	159768000	1	シタイトキリレハシクメタル	LOWER THREAD TRIMMER LEVER SHAFT BUSH	
6	159263001	1	シタイトキリレハハネ	SPRING	
7	141351001	1	セツトカラー	SET COLLAR	
8	014770622	1	アナメネシ"6.35クホ"ミ	SET SCREW 6.35	
9	159264001	1	シタイトキリレハヒン	PIN	
10	014760622	1	アナメネシ"5.95	SET SCREW 5.95	
11	048060342	1	トメフE6	STOP RING E6	
12	025080232	1	ヒラサ"カ"ネチユウ8	PLAIN WASHER 8	
13	159265001	1	シタイトカムレハ	LOWER THREAD TRIMMER CAM LEVER	
14	017762012	1	ボルト5.95X20	BOLT 5.95X20	
15	107744001	1	コロ	ROLLER	
16	141519001	1	イトキリサト"ウカムコロシク	ROLLER SHAFT	
17	110161004	1	ナット4.76	NUT 4.76	
18	048030342	1	トメフE3	STOP RING E3	
19	S19811001	1	シタイトキリカム	LOWER THREAD TRIMMER CAM	
20	159267001	1	シタイトキリカムシク	LOWER THREAD TRIMMER CAM SHAFT	
21	014760622	1	アナメネシ"5.95	SET SCREW 5.95	
22	110494001	1	サ"カ"ネ	WASHER	
23	048080342	1	トメフE8	STOP RING E8	
24	159268001	1	シタイトキリリンク	LOWER THREAD TRIMMER LINK	
25	159269001	1	シタイトキリリンクタ"ンネシ"	LOWER THREAD TRIMMER LINK STUD SCREW	
26	159270001	1	シタイトキリカムタ"ンネシ"	LOWER THREAD TRIMMER CAM STUD SCREW	
27	159271001	1	メスサト"ウレハ"	MOVABLE KNIFE DRIVING LEVER	
28	159272001	1	メスサト"ウレハ"タ"ンネシ"	MOVABLE KNIFE DRIVING LEVER STUD SCREW	
30	159274001	1	シタイトイト"ウハ	MOVABLE KNIFE	
31	S19813001	1	シタイトサハ"キ	LOWER THREAD RETAINER	
32	062670512	2	ナヘ"コ357-40X5	SCREW 357X5	
33	159276201	1	シタイトコテイハ	FIXED KNIFE	
34	110215002	2	シメネシ"3.57	SCREW 3.57	
36-1	S20017101	1	ヘースハリイタ	BASE NEEDLE PLATE	
36-2	S19809001	1	ヘースハリイタ	BASE NEEDLE PLATE	
37	145318001	4	シメネシ"4.37	SCREW 4.37	
38-1	S00996001	1	ハリイタ1.4-16	NEEDLE PLATE 1.4	
38-2	S01964001	1	ハリイタ1.4-L	NEEDLE PLATE 1.4-L	
39	145247001	2	サラネシ"2.38	SCREW 2.38	
40	159281001	1	ヌノイタ	CLOTH PLATE	
41	145318001	4	シメネシ"4.37	SCREW 4.37	
42	S00901001	1	メスサト"ウレハ"サ"カ"ネU	WASHER (U)	
43	S00902001	1	メスサト"ウレハ"サ"カ"ネD	WASHER (D)	
44	S00903001	1	メスサト"ウレハ"カラー	COLLAR	
47	S19812001	1	シタイトホシ"イタ	LOWER THREAD HOLDER PLATE	
<オプション / OPTION PARTS >					
46	S19861001	1	ヘースハリイタ	BASE NEEDLE PLATE	

A1. スタッカー関係 / Stacker mechanism / Anhäufung /
 Mécanisme de l'empileur / Mecanismo de apilador

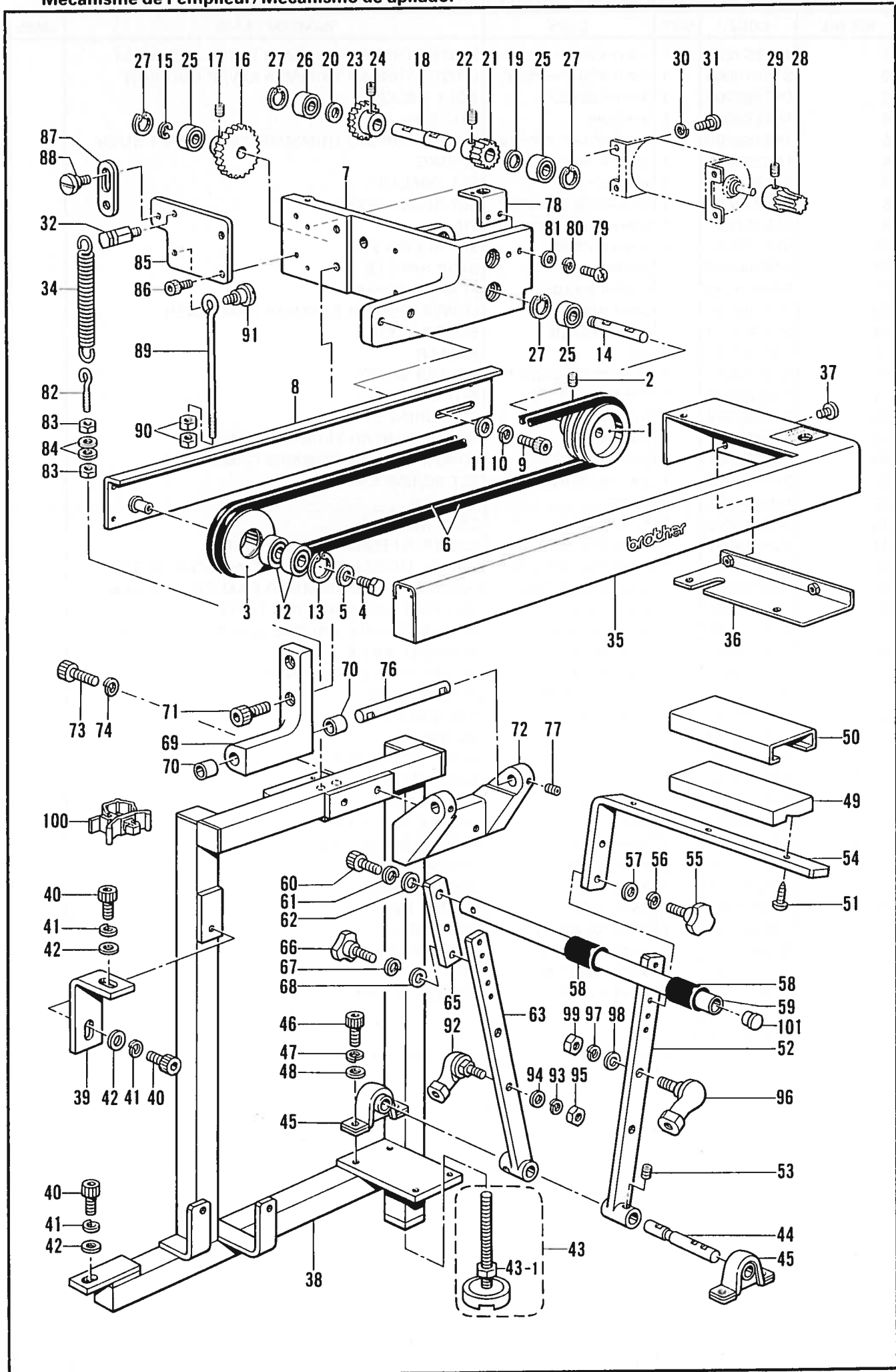

A1. スタッカー関係/Stacker mechanism/Anhäufung/
Mécanisme de l'empileur/Mecanismo de apilador

REF.NO.	CODE	Q'TY	ヒンメイ	NAME OF PARTS	RMKS
1	S11341000	1	ベルトプーリA	BELT PULLEY (A)	
2	014760622	2	アナトメネシ"5.95	SET SCREW 5.95	
3	S11342000	1	ベルトプーリB	BELT PULLEY (B)	
4	017061006	1	ボルト6X10	BOLT 6X10	
5	115947001	1	ワッシャー	WASHER	
6	S11343001	2	ベルト	BELT	
7	S11344009	1	モータササエ	MOTOR SUPPORT	
8	S11345001	1	プーリB ササエウデ"クミ	PULLEY (B) SUPPORT ARM ASSEMBLY	
9	018082022	2	アナボルト8X20	BOLT 8X20	
10	028080242	2	ハ"ネサ"カ"ネ2-8	SPRING WASHER 2-8	
11	025080232	2	ヒラサ"カ"ネチユウ8	PLAIN WASHER 8	
12	072620180	2	タマシ"クウケ6201ZZ	BALL BEARING 6201ZZ	
13	048320242	1	トメフアナヨウC32	STOP RING C32	
14	S11348001	1	プーリA ササエ"ク	PULLEY (A) SUPPORT SHAFT	
15	048060342	1	トメフE6	STOP RING E6	
16	S04378000	1	ギヤ1 X48	GEAR 1X28	
17	014500522	2	アナトメネシ"5クホ"ミ	SET SCREW 5	
18	S04379001	1	ギヤシ"ク	GEAR SHAFT	
19	S04380000	1	スペーサA	SPACER (A)	
20	S04381000	1	スペーサB	SPACER (B)	
21	S04382000	1	ギヤ1 X20	GEAR 1X20	
22	014400522	2	アナクホ"ミ4X5	SET SCREW 4X5	
23	S04383000	1	ギヤ0.75X50	GEAR 0.75X50	
24	014400522	2	アナクホ"ミ4X5	SET SCREW 4X5	
25	070698800	3	タマシ"クウケ698ZZ	BALL BEARING 698ZZ	
26	072062680	1	タマシ"クウケ626ZZ	BALL BEARING 626ZZ	
27	048190242	4	トメフアナヨウC19	STOP RING C19	
28	S00490000	1	スタッカーギヤS	STACKER GEAR (S)	
29	014400522	2	アナクホ"ミ4X5	SET SCREW 4X5	
30	028040243	4	ハ"ネサ"カ"ネ2-4	SPRING WASHER 2-4	
31	062401006	4	ナヘ"コ4X10	SCREW 4X10	
32	159050001	1	ブレーキワイヤササエB	BRAKE WIRE HOOK (B)	
34	S04389001	1	モータササエモト"シハ"ネ	SPRING	
35	S11349009	1	プーリカバー	PULLEY COVER	
36	S11350009	1	プーリカバーB	PULLEY COVER (B)	
37	008400604	11	トラスコ4X6	SCREW 4X6	
38	S14191009	1	スタッカーフレーム	STACKER FREME	
39	S11471001	1	スタッカーキヤクササエ	STACKER FRAME SUPPORT	
40	018081622	3	アナボルト8X16	BOLT 8X16	
41	028080242	3	ハ"ネサ"カ"ネ2-8	SPRING WASHER 2-8	
42	025080232	3	ヒラサ"カ"ネチユウ8	PLAIN WASHER 8	
43	S01265001	1	レベルサ"クミ	LEVEL ADJUSTER ASSEMBLY	
43-1	022120306	1	ナット3シユ12	NUT 12	
44	S04416001	1	スタッカーシテンシ"ク	STACKER FULCRUM SHAFT	
45	149342001	2	ピロフ"ロツク	PILLOW BLOCK	
46	018081222	4	アナボルト8X12	BOLT 8X12	
47	028080242	4	ハ"ネサ"カ"ネ2-8	SPRING WASHER 2-8	
48	025080232	4	ヒラサ"カ"ネチユウ8	PLAIN WASHER 8	
49	S11422009	1	ヌノオキタ"イ	CLOTH PUT BASE	
50	S11423000	1	シート	SHEET	
51	032452502	2	+ マルモクネシ"4.5X25	SCREW 4.5X25	
52	S04421009	1	スタッカーアーム	STACKER ARM	
53	014060622	2	アナトメネシ"6X6クホ"ミ	SET SCREW 6X6	
54	S04420009	1	スタッカーササエウデ"	STACKER SUPPORT ARM	
55	S01856000	2	ツマミボルトM6X20	BOLT M6X20	
56	028060242	2	ハ"ネサ"カ"ネ2-6	SPRING WASHER 2-6	
57	025060232	2	ヒラサ"カ"ネチユウ 6	PLAIN WASHER 6	
58	S04422000	2	ゴムハン"ト"	RUBBER BAND	
59	S11353001	1	ヌノオサエハ"ー	CLOTH PRESSER BAR	
60	018082022	1	アナボルト8X20	BOLT 8X20	
61	028080242	1	ハ"ネサ"カ"ネ2-8	SPRING WASHER 2-8	
62	025080232	1	ヒラサ"カ"ネチユウ8	PLAIN WASHER 8	

A1. スタッカー関係 / Stacker mechanism / Anhäufung /
 Mécanisme de l'empileur / Mecanismo de apilador

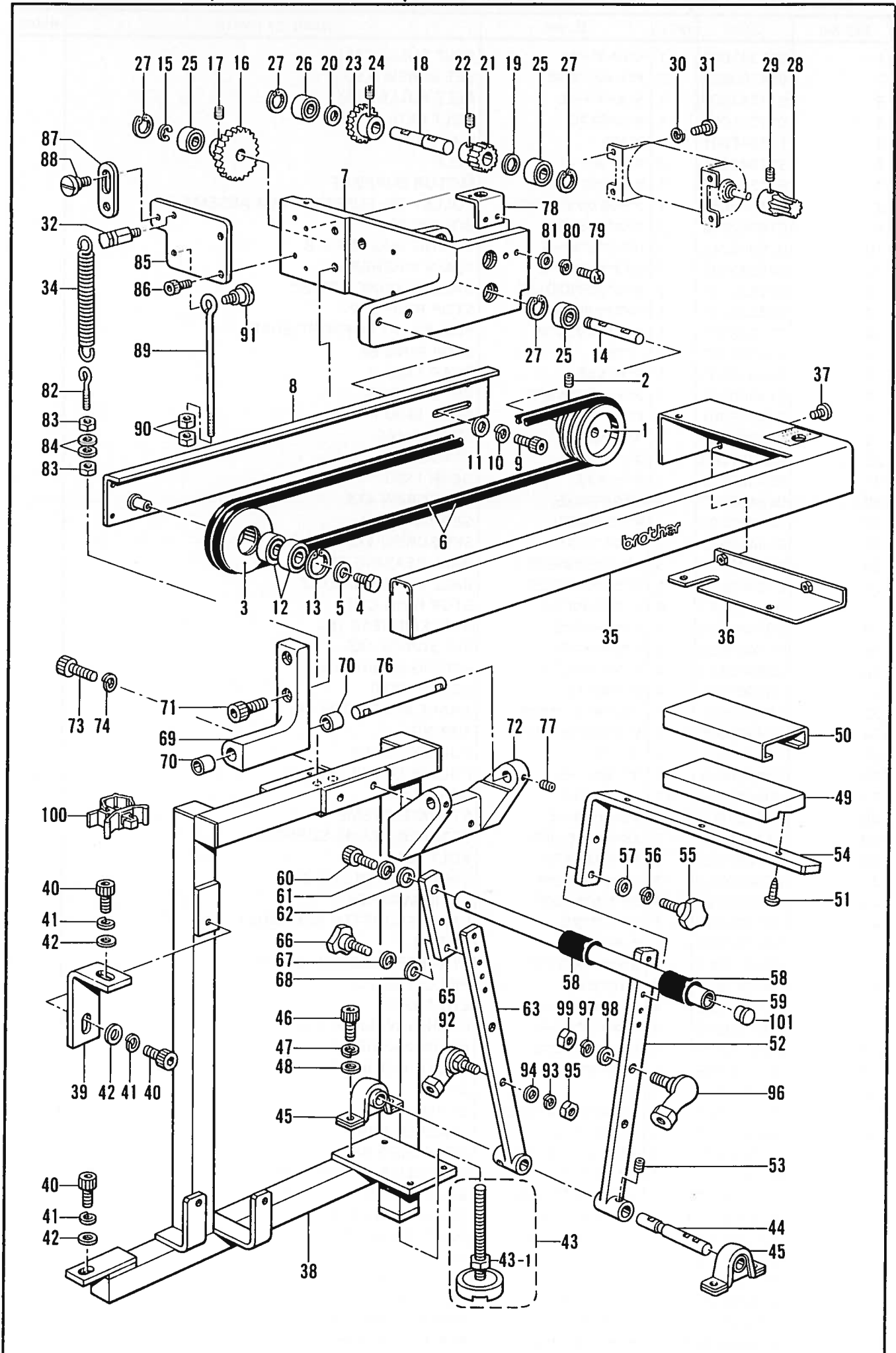

A1. スタッカー関係/Stacker mechanism/Anhäufung/
 Mécanisme de l'empileur/Mecanismo de apilador

REF NO.	CODE	Q'TY	ヒンメイ	NAME OF PARTS	RMKS
63	S04421009	1	スタッカーアーム	STACKER ARM	
65	S11354001	1	ヌノオサエハ"ーサエウテ"	CLOTH PRESSER BAR SUPPORT ARM	
66	S01856000	2	ツマミボ"ルトM6X20	BOLT M6X20	
67	028060242	2	ハ"ネサ"カ"ネ2-6	SPRING WASHER 2-6	
68	025060232	2	ヒラサ"カ"ネチユウ 6	PLAIN WASHER 6	
69	S11355009	1	モータオクリシテン	MOTOR FEED FULCRUM	
70	S11418000	2	ブ"ツシユ12-15	BUSH (12-15)	
71	018082522	2	アナボ"ルト8X25	BOLT 8X25	
72	S14192009	1	モータオクリシテント"ダイ	MOTOR FEED FULCRUM BASE	
73	018082522	2	アナボ"ルト8X25	BOLT 8X25	
74	028080242	2	ハ"ネサ"カ"ネ2-8	SPRING WASHER 2-8	
76	S11357001	1	モータオクリシテンジ"ク	MOTOR FEED FULCRUM SHAFT	
77	014760622	2	アナトメネジ"5.95	SET SCREW 5.95	
78	S04387001	1	スイッチト"ツツケイタ	SWITCH SET PLATED	
79	062401605	2	ナハ"コ4X16	SCREW 4X16	
80	028040243	2	ハ"ネサ"カ"ネ2-4	SPRING WASHER 2-4	
81	025040233	2	ヒラサ"カ"ネチユウ4	PLAIN WASHER 4	
82	140947002	1	ウワイタチヨウセツネジ"	ADJUST SCREW	
83	021400202	2	2シユナツト4	NUT 4	
84	025040232	2	ヒラサ"カ"ネチユウ4	PLAIN WASHER 4	
85	S11359001	1	ローラアケ"イタ	ROLLER LIFTING PLATE	
86	018501422	2	アナボ"ルト5X14	BOLT 5X14	
87	S11360001	1	ローラアケ"リンク	ROLLER LIFTING LINK	
88	145480001	1	タ"ンネジ"6.35	STUD SCREW 6.35	
89	154332001	1	オサエアケ"チヨウセツロツト"	PRESSER BAR LIFTER ADJUST ROD	
90	150556001	2	ナツト6.35	NUT 6.35	
91	150451001	1	タ"ンネジ"6.35	STUD SCREW 6.35	
92	149486001	1	リンクホ"ール	LINK BALL	
93	028080242	1	ハ"ネサ"カ"ネ2-8	SPRING WASHER 2-8	
94	025080232	1	ヒラサ"カ"ネチユウ8	PLAIN WASHER 8	
95	021080302	1	ナツト3シユ8	NUT 8	
96	149487001	1	リンクホ"ール	LINK BALL	
97	028100242	1	ハ"ネサ"カ"ネ2-10	SPRING WASHER 2-10	
98	025100232	1	ヒラサ"カ"ネチユウ10	PLAIN WASHER 10	
99	149488001	1	ロツト"ナツト	ROD NUT	
100	S09142000	4	コード"クランプ"20L	CORD CLAMP 20-L	
101	S00313009	1	メクラセン	OIL CAP	

B1. コントロールボックス関係 / Control box mechanism / Schaltkasten /
 Mécanisme du boîtier de contrôle / Mecanismo de la caja de controles

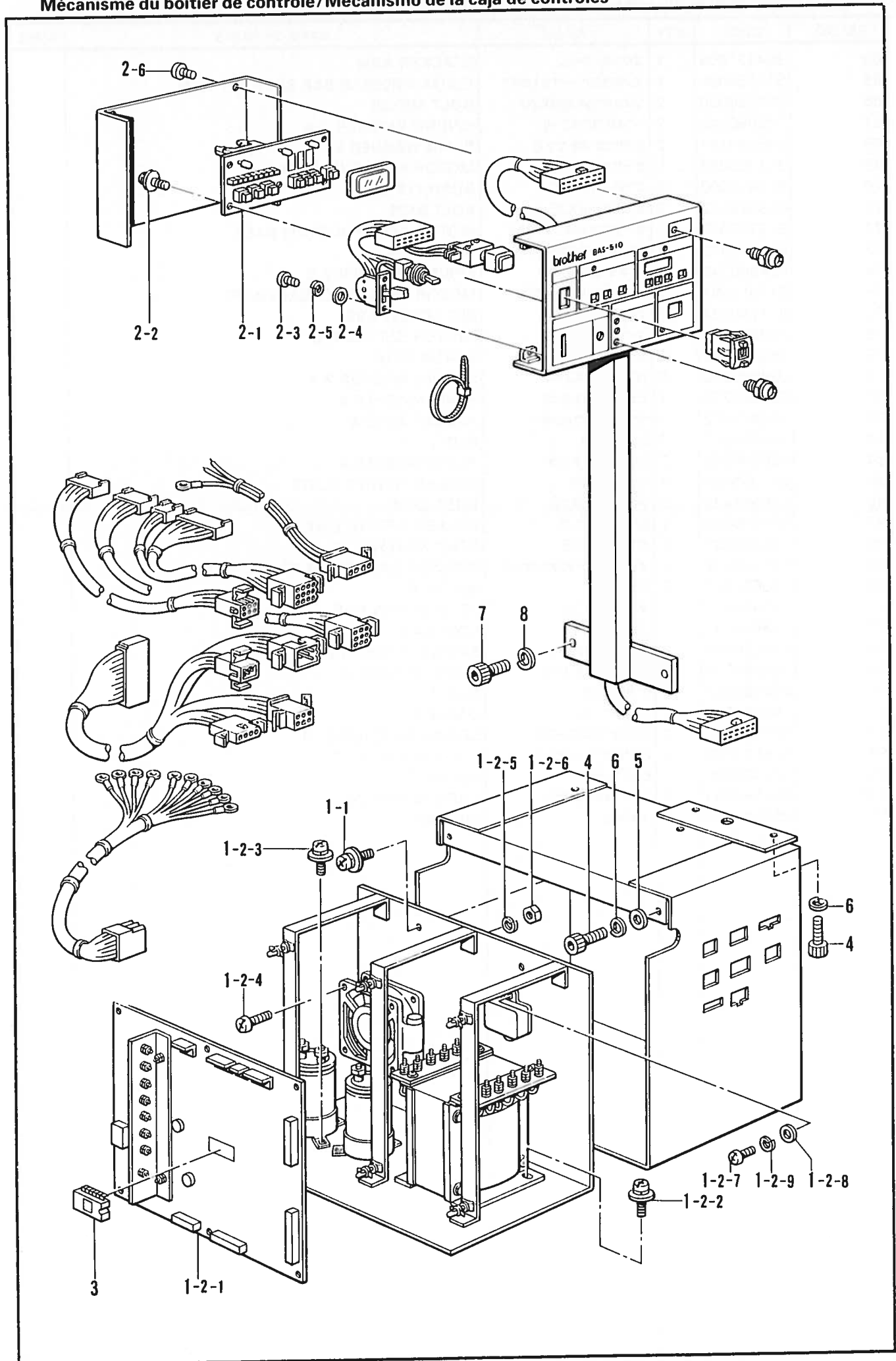

B1. コントロールボックス関係 /Control box mechanism/Schaltkasten/
 Mécanisme du boîtier de contrôle/Mecanismo de la caja de controles

REF.NO.	CODE	Q'TY	ヒンメイ	NAME OF PARTS	RMKS
1	S11535009	1	ホ"ツクスクミ	BOX ASSEMBLY	
1-1	052400806	4	ナヘ"コハ"ネヒラ4X8	WASHER SCREW 4X8	
1-2-1	S11537000	1	キハ"ンB439036クミ	PRINTED CIRCUIT BOARD (B439036) ASSEMBLY	
1-2-2	052400806	4	ナヘ"コハ"ネヒラ4X8	WASHER SCREW 4X8	
1-2-3	S18658001	6	ナヘ"コハ"ネヒラ4X6	WASHER SCREW 4X6	
1-2-4	002401403	4	+ナヘ"ネジ"4X14	SCREW 4X14	
1-2-5	028040243	4	ハ"ネサ"カ"ネ2-4	SPRING WASHER 2-4	
1-2-6	021400103	4	ナツト1シユ4	NUT 4	
1-2-7	002300803	2	+ナヘ"ネジ"3X8	SCREW 3X8	
1-2-8	025030233	2	ヒラサ"カ"ネチユウ3	PLAIN WASHER 3	
1-2-9	028030243	2	ハ"ネサ"カ"ネ2-3	SPRING WASHER 2-3	
2	S11467009	1	ソウサホ"ツクスクミ	OPERATION BOX ASSEMBLY	
2-1	S11550000	1	キハ"ンB438004クミ	PRINTED CIRCUIT BOARD (B438004) ASSEMBLY	
2-2	052400806	4	ナヘ"コハ"ネヒラ4X8	WASHER SCREW 4X8	
2-3	062300505	2	ナヘ"コ3X5	SCREW 3X5	
2-4	025030233	2	ヒラサ"カ"ネチユウ3	PLAIN WASHER 3	
2-5	028030243	2	ハ"ネサ"カ"ネ2-3	SPRING WASHER 2-3	
2-6	008400604	4	+トラスコ4X6	SCREW 4X6	
3	S11540000	1	PROM510クミ	PROM 510 ASSEMBLY	
4	018061622	4	アナホ"ルト6X16	BOLT 6X16	
5	025060232	2	ヒラサ"カ"ネチユウ 6	PLAIN WASHER 6	
6	028060242	4	ハ"ネサ"カ"ネ2-6	SPRING WASHER 2-6	
7	018081622	2	アナホ"ルト8X16	BOLT 8X16	
8	028080242	2	ハ"ネサ"カ"ネ2-8	SPRING WASHER 2-8	

C1. 空圧関係(1)/Air pressure mechanism (1)/Luftdruck (1)/
 Mécanisme de la pression d'air (1)/Mecanismo de la presión de aire (1)

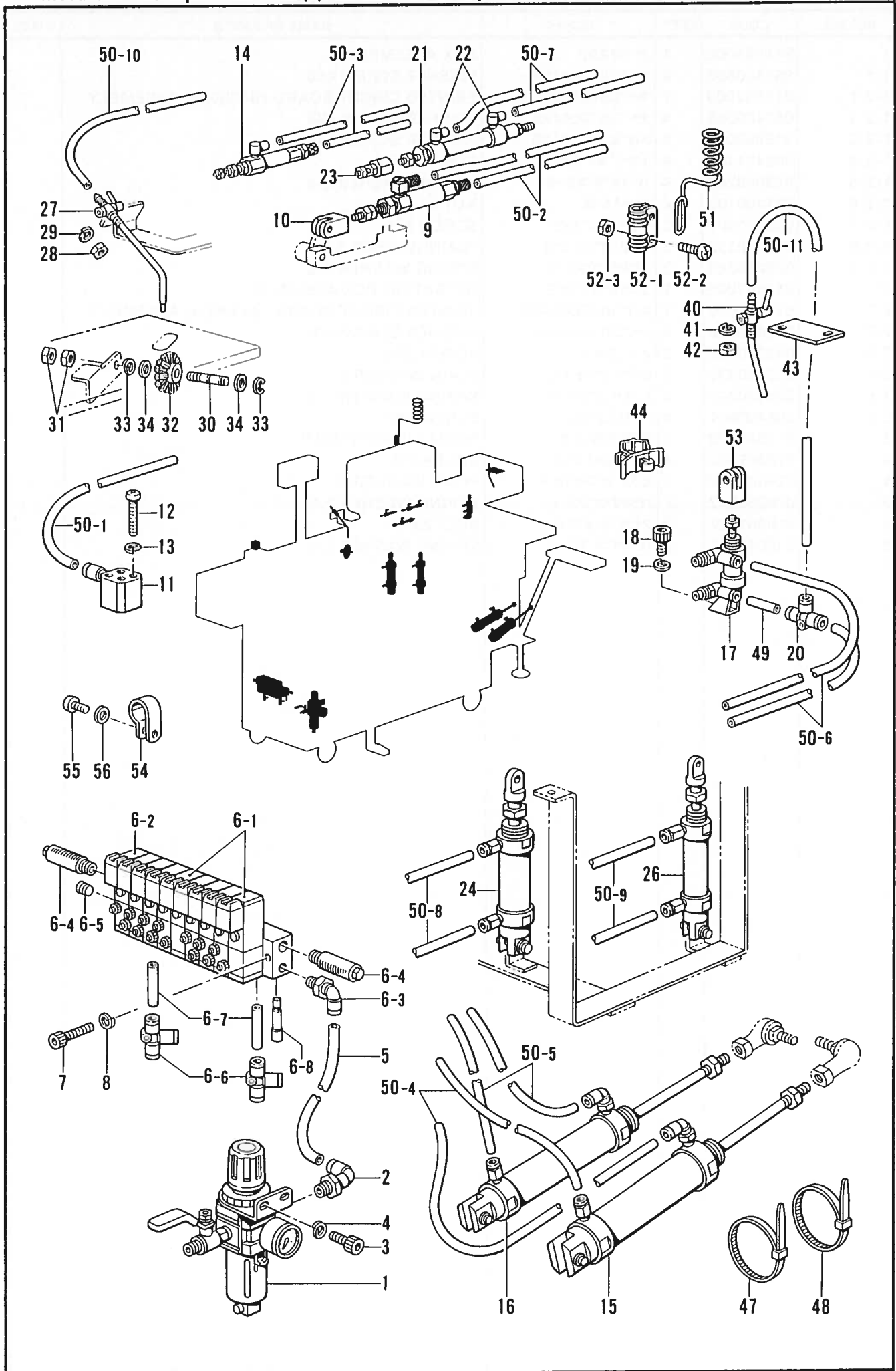

C1. 空圧関係(1)/Air pressure mechanism (1)/Luftdruck (1)/
 Mécanisme de la pression d'air (1)/Mecanismo de la presión de aire (1)

REF.NO.	CODE	Q'TY	ヒンメイ	NAME OF PARTS	RMKS
1	S11420100	1	エアユニット	AIR UNIT	
2	S04896000	1	エルボ"ユニオン	ELBOW UNION	
3	018060822	2	アナボ"ルト6X8	BOLT 6X8	
4	028060242	2	ハ"ネサ"カ"ネ2-6	SPRING WASHER 2-6	
5	S11421000	1	エアチューブ"	AIR TUBE	
6	S11363001	1	ハ"ルブ"ユニット	VALVE UNIT	
6-1	S09188100	2	ハ"ルブ"VZ3140	VALVE VZ3140	
6-2	S09189100	7	ハ"ルブ"VZ3150	VALVE VZ3150	
6-3	S01542000	1	エルボ"ユニオン61	ELBOW UNION 61	
6-4	140682001	2	サイレンサー	SILENCER	
6-5	153274001	1	1/8トメセン	CAP 1/8	
6-6	S01202000	1	チース"	T-JOINT	
6-7	S09192001	1	チューブ"	OIL TUBE	
6-8	S04897000	1	メクラセン	BLIND CAP	
7	018503022	2	アナボ"ルト5X30	BOLT 5X30	
8	028050242	2	ハ"ネサ"カ"ネ2-5	SPRING WASHER 2-5	
9	S11428000	1	エアシリンダ"10X15クミ	AIR CYLINDER ASSEMBLY (10X15)	
10	S11430000	1	ナツクルジ"ヨイント	KNUCKLE JOINT	
11	S11481000	1	エアシリンダ"12X10クミ	AIR CYLINDER ASSEMBLY(12X10)	
12	002303003	2	フラスナヘ"ネジ"3X30	SCREW 3X30	
13	028030242	2	ハ"ネサ"カ"ネ2-3	SPRING WASHER 2-3	
14	S11431000	1	エアシリンダ"6X15クミ	AIR CYLINDER ASSEMBLY (6X15)	
15	S11434000	1	エアシリンダ"30X125クミ	AIR CYLINDER ASSEMBLY (30X125)	
16	S11436000	1	エアシリンダ"25X125クミ	AIR CYLINDER ASSEMBLY (25X125)	
17	S11438000	1	エアシリンダ"16X25クミ	AIR CYLINDER ASSEMBLY(16X25)	
18	018400822	2	アナボ"ルト4X8	BOLT 4X8	
19	028040242	2	ハ"ネサ"カ"ネ2-4	SPRING WASHER 2-4	
20	S01202000	1	チース"	T-JOINT	
21	S11425000	1	エアシリンダ"10X30クミ	AIR CYLINDER ASSEMBLY (10X30)	
22	S12150000	2	ホースエルボ"M-5HL-4	TUBE ELBOW (M-5HL-4)	
23	S11427000	1	フローティング"シ"ヨイント	FLOATING JOINT	
24	S01213000	1	エアシリンダ"25-50クミ	AIR CYLINDER ASSEMBLY(25-50)	
26	S09610000	1	エアシリンダ"20-50クミ	AIR CYLINDER ASSEMBLY(20-50)	
27	S11482001	1	ガ"イト"ブ"ローノズ"ルクミ	GUIDE BLOW NOZZLE ASSEMBLY	
28	021500103	1	ナツト1 シュ5	NUT 5	
29	028050243	1	ハ"ネサ"カ"ネ2-5	SPRING WASHER 2-5	
30	S01657001	1	ローラシ"ク	ROLLER SHAFT	
31	021060102	2	ナツト1 シュ6	NUT 6	
32	407437001	1	スレツト"ハケク"ルマ	WEAVING PATTERN BRUSH	
33	048050342	2	トメフE5	STOP RING E5	
34	025060232	4	ヒラサ"カ"ネチユウ 6	PLAIN WASHER 6	
40	S06622001	1	スタツカー"ノズ"ル	STACKER NOZZLE	
41	028050243	1	ハ"ネサ"カ"ネ2-5	SPRING WASHER 2-5	
42	021500103	1	ナツト1 シュ5	NUT 5	
43	S06621001	1	ノズ"ルササエ	NOZZLE SUPPORT	
44	150349001	1	コード"クランプ"10-L	CORD CLAMP 10-L	
47	S06143000	1	ハンタイPLT4S	BAND PLT4S	
48	S04557000	6	ハンタイPLTIM	BAND PLTIM	
49	S09192001	1	チューブ"	OIL TUBE	
50-1	S11440001	1	エアチューブ"	AIR TUBE	
50-2	S11440002	2	エアチューブ"	AIR TUBE	
50-3	S11440002	2	エアチューブ"	AIR TUBE	
50-4	S11440003	2	エアチューブ"	AIR TUBE	
50-5	S11440004	2	エアチューブ"	AIR TUBE	
50-6	S11440005	2	エアチューブ"	AIR TUBE	
50-7	S11440006	2	エアチューブ"	AIR TUBE	
50-8	S11440007	2	エアチューブ"	AIR TUBE	
50-9	S11440009	2	エアチューブ"	AIR TUBE	
50-10	S11440003	1	エアチューブ"	AIR TUBE	
50-11	S11440011	1	エアチューブ"	AIR TUBE	
51	S11365000	1	チューブ"ササエコイル	AIR TUBE SUPPORT COIL	

C1. 空圧関係(1)/Air pressure mechanism (1)/Luftdruck (1)/
 Mécanisme de la pression d'air (1)/Mecanismo de la presión de aire (1)

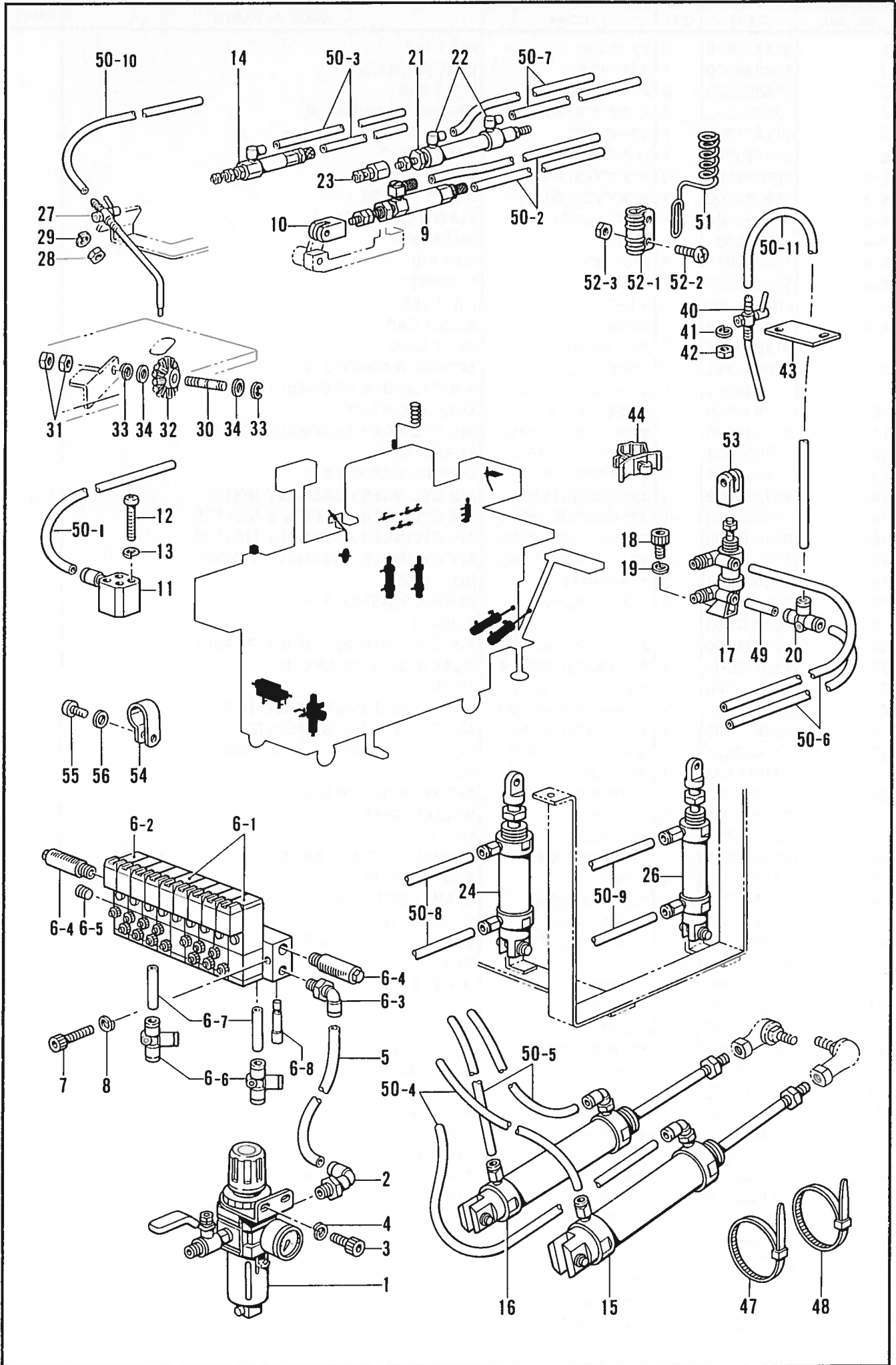

C1. 空圧関係(1)/Air pressure mechanism (1)/Luftdruck (1)/
 Mécanisme de la pression d'air (1)/Mecanismo de la presión de aire (1)

REF. NO.	CODE	Q'TY	ヒンメイ	NAME OF PARTS	RMKS
52	150106003	1	コラムシ"ヨイントクミ	COLUMN JOINT ASSEMBLY	
52-1	150173003	1	コラムシ"ヨイント	COLUMN JOINT	
52-2	062501406	2	ナヘ"コ5X14	SCREW 5X14	
52-3	021500106	2	1シユナツト5	NUT 5	
53	S11475000	1	ナツクルシ"ヨイント	KNUCKLE JOINT	
54	525907000	1	コード"ホルダ"9N	CORD HOLDER 9N	
55	062401006	1	ナヘ"コ4X10	SCREW 4X10	
56	025040232	1	ヒラサ"カ"ネチユウ4	PLAIN WASHER 4	

C1. 空圧関係(2) / Air pressure mechanism (2) / Luftdruck (2) /
 Mécanisme de la pression d'air (2) / Mecanismo de la presión de aire (2)

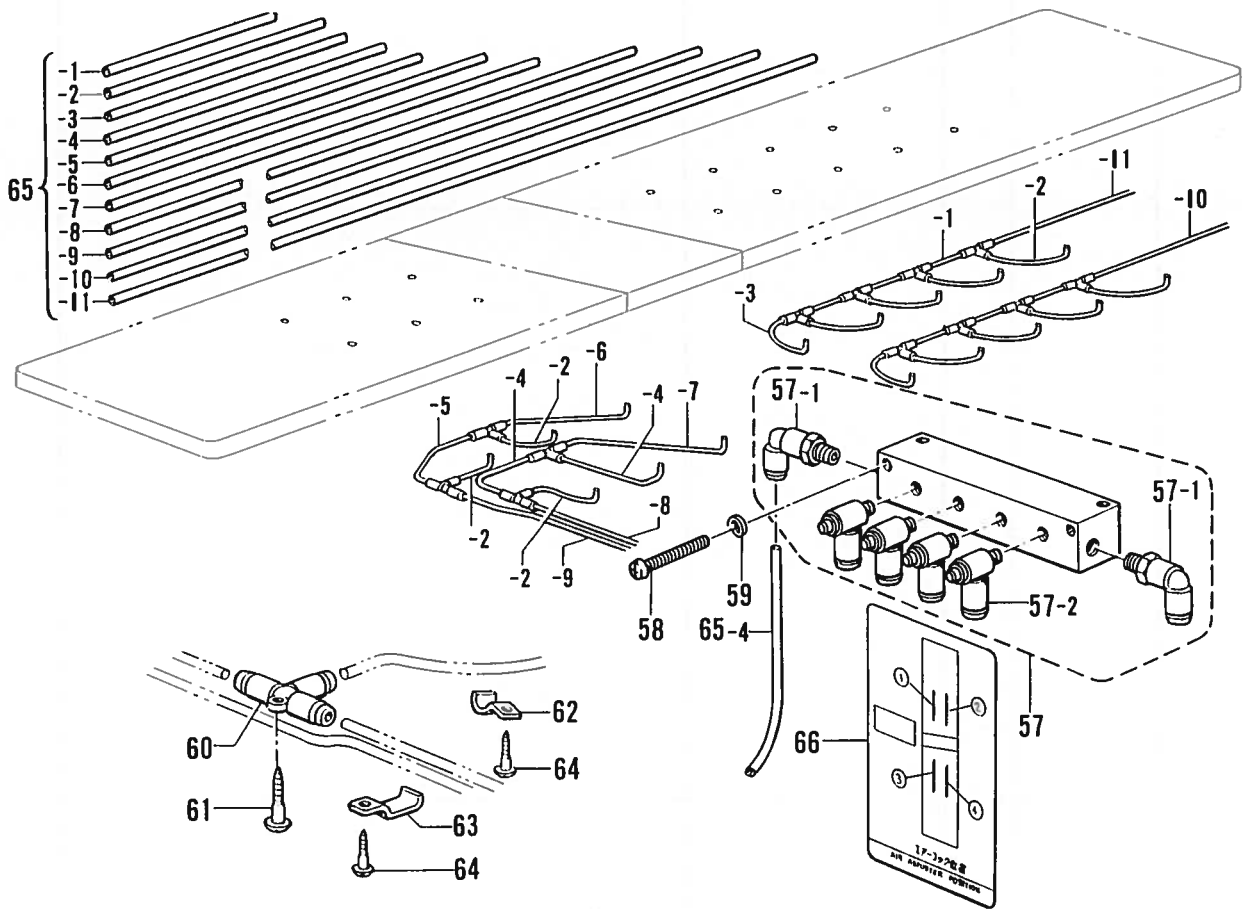

C1. 空圧関係(2)/Air pressure mechanism (2)/Luftdruck (2)/
 Mécanisme de la pression d'air (2)/Mecanismo de la presión de aire (2)

REF NO.	CODE	Q'TY	品名	NAME OF PARTS	RMKS
57	S14084001	1	エア-コックユニット	AIR COCK UNIT	
57-1	S04909000	2	エルボ"ユニオン	ELBOW UNION	
57-2	S14328000	4	シボ"リヘ"ン	THROTTLE VALVE	
58	062303012	2	ナヘ"コM3X30	SCREW M3X30	
59	028030242	2	ハ"ネサ"カ"ネ2-3	SPRING WASHER 2-3	
60	S01202000	12	チ-ス"	T-JOINT	
61	032422006	12	+マルモクネシ"4.1X20	SCREW 4.1X20	
62	140647001	15	コート"オサエ	CORD HOLDER	
63	142268001	3	コート"オサエL	CORD HOLDER (L)	
64	032311306	18	+マルモクネシ"3.1X13	SCREW 3.1X13	
65-1	S14085001	6	エア-チューブ"	AIR TUBE	
65-2	S14085002	11	エア-チューブ"	AIR TUBE	
65-3	S14085003	2	エア-チューブ"	AIR TUBE	
65-4	S14085004	3	エア-チューブ"	AIR TUBE	
65-5	S14085005	1	エア-チューブ"	AIR TUBE	
65-6	S14085006	1	エア-チューブ"	AIR TUBE	
65-7	S14085007	1	エア-チューブ"	AIR TUBE	
65-8	S14085008	1	エア-チューブ"	AIR TUBE	
65-9	S14085009	1	エア-チューブ"	AIR TUBE	
65-10	S14085010	1	エア-チューブ"	AIR TUBE	
65-11	S14085011	1	エア-チューブ"	AIR TUBE	
66	S14150001	1	エア-コックラヘ"ル	AIR COCK LABEL	

D1. 電装品関係(1)/Power supply equipment mechanism (1)/Stromversorgung (1)/
 Mécanisme de l'équipement en alimentation électrique (1)/
 Mecanismo del equipo de alimentación de corriente (1)

REF.NO.	CODE	Q'TY	ヒンメイ	NAME OF PARTS	RMKS
1	S11541000	1	デ"ンゲ"ンハーネスA	POWER SUPPLY HARNESS (A)	
2	S08105000	1	POWハーネスBクミ	POWER HARNESS (B) ASSEMBLY	
3	S11543000	1	モータハーネス	MOTOR HARNESS	
4	S11544000	1	オサエSWハーネス	PRESSER SWITCH HARNESS	
5	S11545000	1	パ"ルスモータハーネス	PULSE MOTOR HARNESS	
6	*	1	ブ"レーカ	BREAKER	
7	S04499001	1	スタツカモータクミ	STACKER MOTOR ASSEMBLY	
8	S04384001	1	キハ"ンササエ	CIRCUIT BOARD BASE PLATE	
9	S04385000	1	シ"シヤククミ	MAGNET ASSEMBLY	
10	014400422	2	アナトメネシ"4X4クホ"ミ	SET SCREW 4X4	
11	S04500001	1	カイテンセンサクミA	RATATIONAL SENSOR ASSEMBLY (A)	
12	062300605	2	ナヘ"コ3X6	SCREW 3X6	
13	028030243	2	ハ"ネサ"カ"ネ2-3	SPRING WASHER 2-3	
14	021300103	2	ナツト1シユ3	NUT 3	
15	S04561000	1	スタツカSWクミ	STACKER SWITCH ASSEMBLY	
16	S04564000	1	スタツカケーブル"ルB	STAKER CABLE (B)	
17	S04565001	1	パ"ルスモータクミ	PULSE MOTOR ASSEMBLY	
18	S04566001	1	DCモータクミ	DC MOTOR ASSEMBLY	
19	S11548000	1	DCモータハーネス	DC MOTOR HARNESS	
20	S18013001	1	ゲ"ンテンセンサークミ	HOME POSITION SENSOR ASSEMBLY	
21	S11546000	1	スタツカハーネスA	STACKER HARNESS (A)	
22	S11552009	1	トウフ"スイツチクミ	HEAD SWITCH ASSEMBLY	
22-1	S11553000	1	イトキレカンチSWクミ	THREAD BREAKAGE SWITCH ASSEMBLY	
22-2	S11554001	1	クラツチSWクミ	CLUTCH SWITCH ASSEMBLY	
22-3	S11555000	1	オサエアケ"SWクミ	PRESSER BAR LIFTER SWITCH ASSEMBLY	
22-4	S11556001	1	スタートSWクミ	START SWITCH ASSEMBLY	
23	S11486009	1	イトキレSWトリツケイタ	THREAD BREAKAGE SWITCH PLATE	
24	S11487001	1	イトキレSWレハ"ー	THREAD BREAKAGE SWITCH LEVER	
25	S11488001	1	SWオシハ"ネ	SPRING	
26	112144001	1	タ"ンネシ"3.57	STUD SCREW 3.57	
27	018402032	1	アナホ"ルト4X20	BOLT 4X20	
28	021400202	1	2シユナツト4	NUT 4	
29	062301606	2	ナヘ"コ3X16	SCREW 3X16	
30	028030243	2	ハ"ネサ"カ"ネ2-3	SPRING WASHER 2-3	
31	025030233	2	ヒラサ"カ"ネチユウ3	PLAIN WASHER 3	
32	021300103	2	ナツト1シユ3	NUT 3	
33	149547000	1	コート"オサエ4N	CORD HOLDER 4N	
34	008400604	1	+トラスコ4X6	SCREW 4X6	
35	018400532	1	アナホ"ルト4X5	BOLT 4X5	
36	062680512	1	ナヘ"コ437-40X5	SCREW 437X5	
37	062402512	2	ナヘ"コ4X25	SCREW 4X25	
38	025040233	2	ヒラサ"カ"ネチユウ4	PLAIN WASHER 4	
39	149547000	2	コート"オサエ4N	CORD HOLDER 4N	
40	525664000	1	コート"ホルダ"6N	CORD HOLDER 6N	
41	062670512	3	ナヘ"コ357-40X5	SCREW 357X5	
42	554482000	2	コート"ホルダ"12N	CORD HOLDER 12N	
43	140647001	1	コート"オサエ	CORD HOLDER	
44	142268001	1	コート"オサエL	CORD HOLDER (L)	
45	062660512	1	ナヘ"コネシ"318-40X5	SCREW 318X5	
46	S10543009	1	SWトリツケイタA	SWITCH SET PLATE (A)	
47	S10544009	1	SWトリツケイタB	SWITCH SET PLATE (B)	
48	062300605	2	ナヘ"コ3X6	SCREW 3X6	
49	028030243	2	ハ"ネサ"カ"ネ2-3	SPRING WASHER 2-3	
50	025030233	2	ヒラサ"カ"ネチユウ3	PLAIN WASHER 3	
51	062301606	2	ナヘ"コ3X16	SCREW 3X16	
52	028030243	2	ハ"ネサ"カ"ネ2-3	SPRING WASHER 2-3	
53	025030233	2	ヒラサ"カ"ネチユウ3	PLAIN WASHER 3	
54	021300103	2	ナツト1シユ3	NUT 3	
55	149069101	1	アクチュエータ	ACTUATOR	
56	149070009	1	スイツチカバー	SWITCH COVER	
57	522990001	2	サ"ツキシメネシ"3X19	SCREW 3X19	

D1. 電装品関係(1)/Power supply equipment mechanism (1)/Stromversorgung (1)/
 Mécanisme de l'équipement en alimentation électrique (1)/
 Mecanismo del equipo de alimentación de corriente (1)

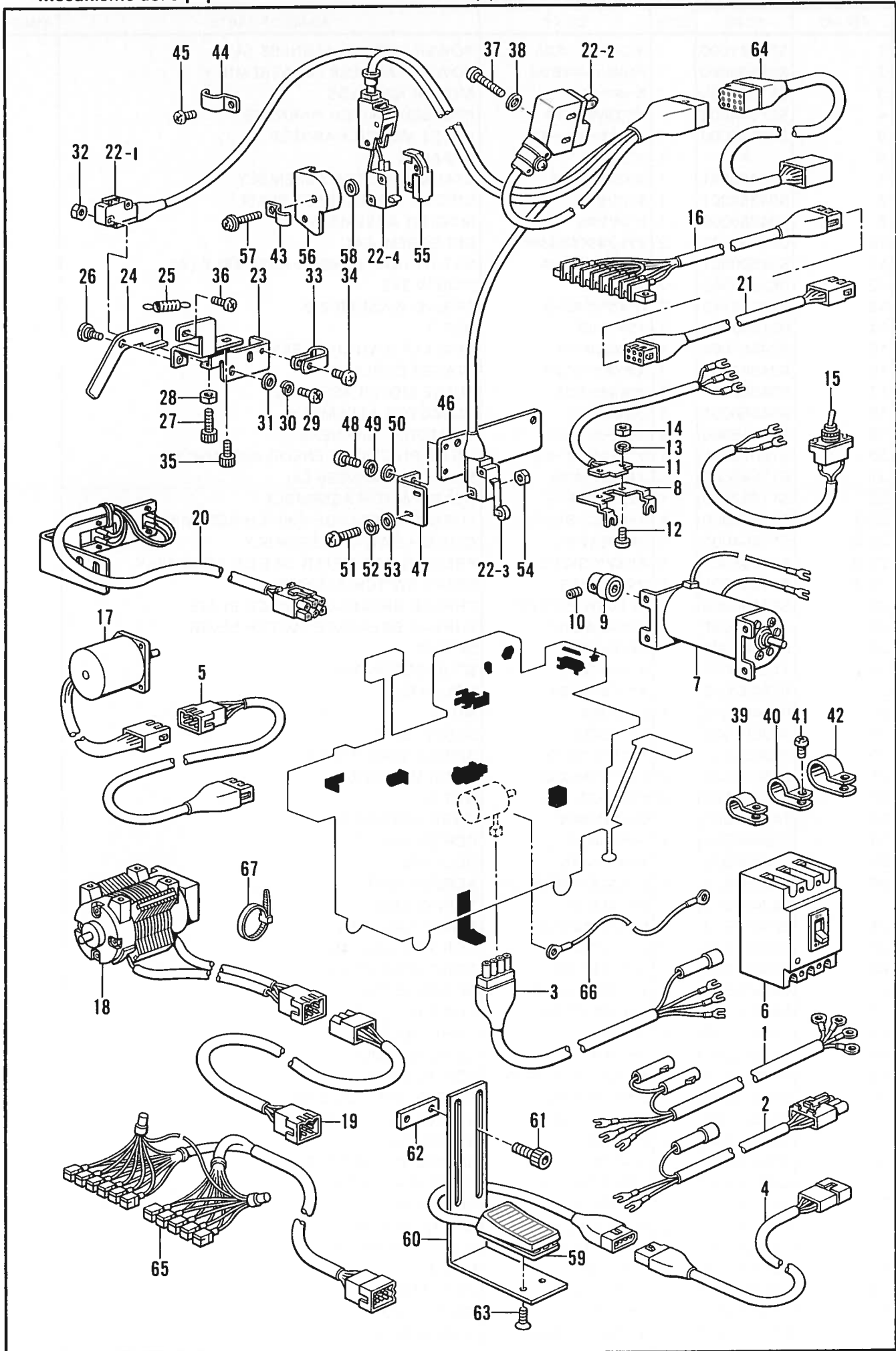

D1. 電装品関係(1)/Power supply equipment mechanism (1)/Stromversorgung (1)/
 Mécanisme de l'équipement en alimentation électrique (1)/
 Mecanismo del equipo de alimentación de corriente (1)

REF.NO.	CODE	Q'TY	ヒンメイ	NAME OF PARTS	RMKS
58	025030233	2	ヒラサ"カ"ネチユウ3	PLAIN WASHER 3	
59	S04573000	1	オサISWクミ	PRESSER SWITCH ASSEMBLY	
60	S04602001	1	オサISWトリツケイタ	PRESSER SWITCH SET PLATE	
61	018061422	2	アナホ"ルト6X14	BOLT 6X14	
62	S00635001	1	スイッチネジ"イタ	SWITCH PLATE	
63	004400802	2	+ サラネジ"4X8	SCREW 4X8	
64	S11557001	1	トウブ"SWハーネス	HEAD SWITCH HARNESS	
65	S11558000	1	ハ"ルブ"ハーネスBクミ	VALVE HARNESS ASSEMBLY (B)	
66	S11551000	1	アースコート"	EARTH WIRE	
67	S04557000	2	ハ"ンタイPLTIM	BAND PLTIM	

D1. 電装品関係(2) / Power supply equipment mechanism (2) / Stromversorgung (2) /
Mécanisme de l'équipement en alimentation électrique (2) /
Mecanismo del equipo de alimentación de corriente (2)

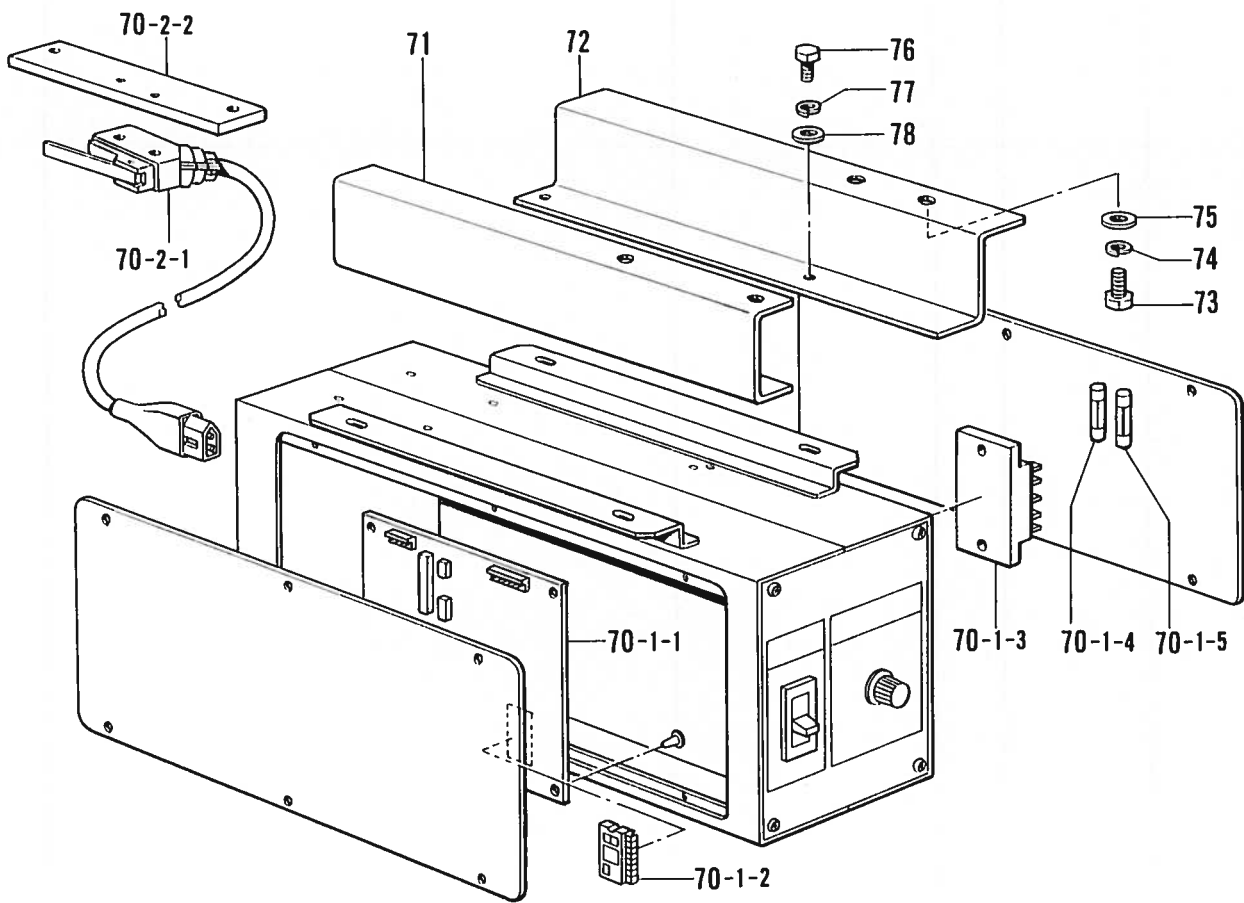

D1. 電装品関係(2)/Power supply equipment mechanism (2)/Stromversorgung (2)/
 Mécanisme de l'équipement en alimentation électrique (2)/
 Mecanismo del equipo de alimentación de corriente (2)

REF NO.	CODE	Q'TY	ヒンメイ	NAME OF PARTS	RMKS
<カハソクモータヨウ /FOR VARIABLE SPEED MOTOR >					
70	183643009	1	コントロールBOXセット	CONTROL BOX SET	
70-1	S14453009	1	ボックスクミ	BOX ASSEMBLY	
70-1-1	S15361001	1	キハ"ンB439049クミ	CIRCUIT BOARD (B439049) ASSEMBLY	
70-1-2	S14037000	1	PROM815クミ	PROM 815 ASSEMBLY	
70-1-3	S08038000	1	TRアレイ6DI10A	TR ALLEY 6DI-10A	
70-1-4	S08030000	1	Gヒューズ"5AFB	G FUSE (5AFB)	
70-1-5	215769001	1	カンヒューズ"3A	FUSE 3A	
70-2-1	S14045000	1	テイソクSW	SWITCH	
70-2-2	S14419001	1	SWトリツケイタ	SWITCH SET PLATE	
71	S14417009	1	BOXトリツケイタA	BOX SET PLATE (A)	
72	S14418009	1	BOXトリツケイタB	BOX SET PLATE (B)	
73	017081606	4	ボ"ルト8X16	BOLT 8X16	
74	028080246	4	ハ"ネサ"カ"ネ2-8	SPRING WASHER 2-8	
75	025080236	4	ヒラサ"カ"ネチユウ8	PLAIN WASHER 8	
76	017501003	4	ボ"ルト5X10	BOLT 5X10	
77	028050243	4	ハ"ネサ"カ"ネ2-5	SPRING WASHER 2-5	
78	025050233	4	ヒラサ"カ"ネチユウ5	PLAIN WASHER 5	

E1. 布制御関係 / Cloth control system mechanism / Stoffführungsvorrichtung /
 Mécanisme de la système de contrôle du tissu / Mecanismo de la sistema de control de tela

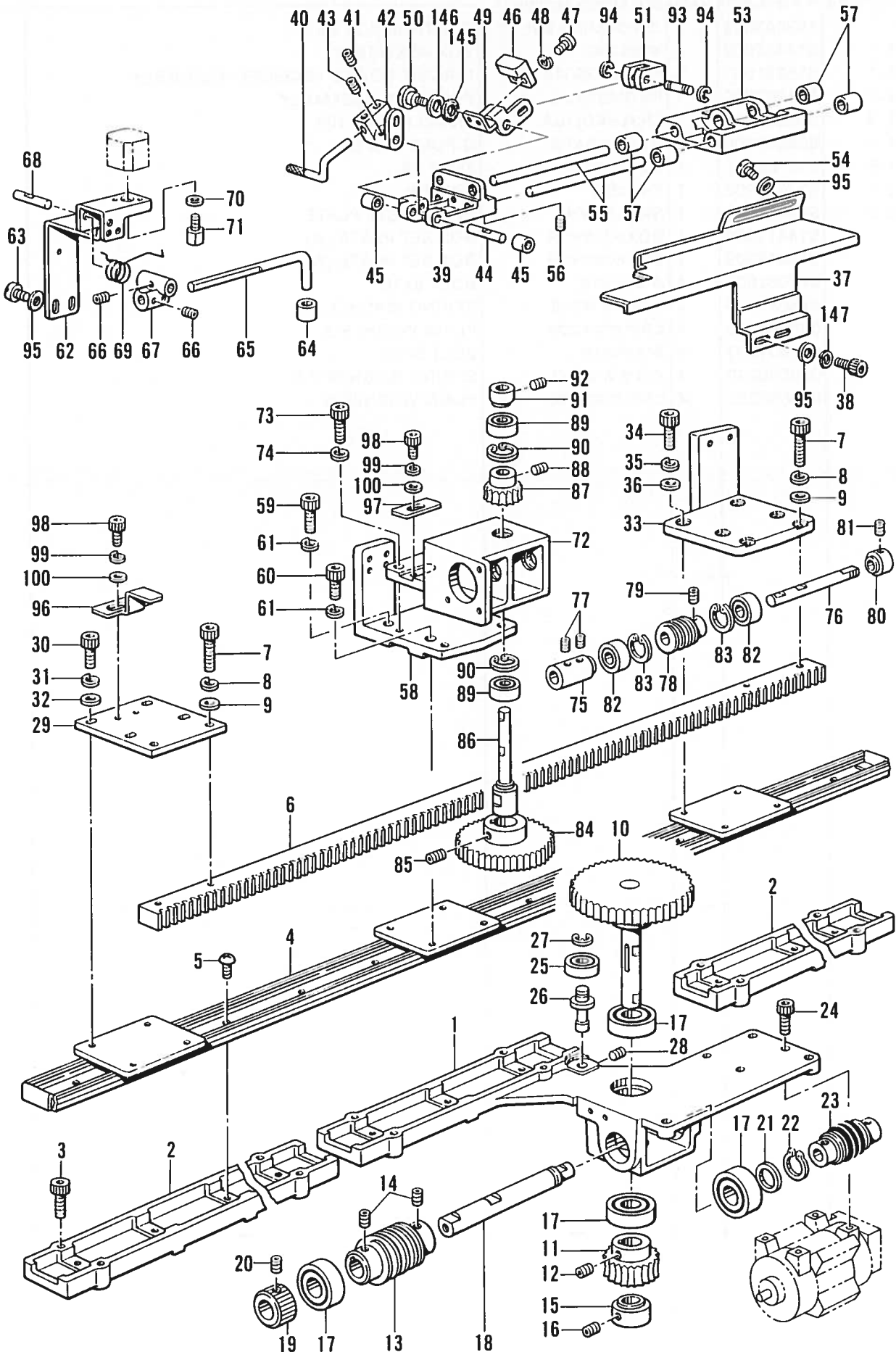

E1. 布制御関係 / Cloth control system mechanism / Stoffführungsrichtung /
 Mécanisme de la système de contrôle du tissu / Mecanismo de la sistema de control de tela

REF NO.	CODE	Q'TY	ヒンメイ	NAME OF PARTS	RMKS
1	S11366001	1	モータササエタイ	MOTOR SUPPORT BRACKET	
2	S04447001	2	スライド"ハ"ツクアンナイ	SLIDE PACK GUIDE	
3	018501622	14	アナボ"ルト5X16	BOLT 5X16	
4	S04574000	1	スライド"ハ"ツク1500L	SLIDE PACK 1500L	
5	008400604	15	+トラスコ4X6	SCREW 4X6	
6	S04443000	1	ラック	RACK	
7	018502022	4	アナボ"ルト5X20	BOLT 5X20	
8	028050242	4	ハ"ネサ"カ"ネ2-5	SPRING WASHER 2-5	
9	146354001	4	サ"カ"ネ	WASHER	
10	S04435001	1	ウオームホイールシ"ククミ	WORM WHEEL SHAFT ASSEMBLY	
11	S11367000	1	ウオームホイール1.5	WORM WHEEL 1.5	
12	014760622	2	アナトメネシ"5.95	SET SCREW 5.95	
13	S04441000	1	ウオーム1.5	WORM 1.5	
14	014060632	2	アナトメ6X6クホ"ミ	SET SCREW 6X6	
15	S04438001	1	セツトカラー	SET COLLAR	
16	014060632	2	アナトメ6X6クホ"ミ	SET SCREW 6X6	
17	076201850	4	タマシ"クウケ6201ZZNR	BALL BEARING 6201ZZNR	
18	S11368001	1	ウオームシ"ク	WORM SHAFT	
19	S11369001	1	セツトカラー	SET COLLAR	
20	014060632	2	アナトメ6X6クホ"ミ	SET SCREW 6X6	
21	S04440001	1	ウオームシ"クカラー	WORM SHAFT COLLAR	
22	048120142	1	トメワシ"クヨウC12	STOP RING C12	
23	153689001	1	ツキ"テAクミ	UNIVERSAL JOINT (A) ASSEMBLY	
24	018401622	4	アナボ"ルト4X16	BOLT 4X16	
25	070698800	1	タマシ"クウケ698ZZ	BALL BEARING 698ZZ	
26	S04434001	1	カムフォロワーシ"ク	SHAFT	
27	048060342	1	トメワE6	STOP RING E6	
28	014060632	1	アナトメ6X6クホ"ミ	SET SCREW 6X6	
29	S11370000	1	Bラックササエタイ	(B) RACK SUPPORT BRACKET	
30	018501022	4	アナボ"ルト5X10	BOLT 5X10	
31	028050242	4	ハ"ネサ"カ"ネ2-5	SPRING WASHER 2-5	
32	025050232	4	ヒラサ"カ"ネチユウ-5	PLAIN WASHER 5	
33	S14205000	1	Rクランプ"タイC	(R) CLAMP BASE (C)	
34	018501422	4	アナボ"ルト5X14	BOLT 5X14	
35	028050242	4	ハ"ネサ"カ"ネ2-5	SPRING WASHER 2-5	
36	146354001	4	サ"カ"ネ	WASHER	
37	*	1	Rクランプ"ササエ	(R) CLAMP SUPPORT	
38	S07959001	2	アナボ"ルト476-32X14	BOLT 476X4	
39	S11373000	1	Rクランプ"タイA	(R) CLAMP BRACKET (A)	
40	S11374001	1	Rクランプ"	(R) CLAMP	
41	014680622	2	アナトメネシ"4.37クホ"ミ	SET SCREW 4.37	
42	S11375001	1	Rクランプ"レハ-	(R) CLAMP LEVER	
43	014680622	1	アナトメネシ"4.37クホ"ミ	SET SCREW 4.37	
44	S11376001	1	Rクランプ"レハ"-シ"ク	(R) CLAMP LEVER SHAFT	
45	S11442000	2	フ"ツシユ5-6	BUSH (5-6)	
46	S11378001	1	センタン"カ"イト"	POINT GUIDE	
47	062300605	2	ナヘ"コ3X6	SCREW 3X6	
48	028030242	2	ハ"ネサ"カ"ネ2-3	SPRING WASHER 2-3	
49	*	1	センタン"カ"イト"レハ-	POINT GUIDE LEVER	
50	S03441001	1	ダンネシ"4.76	STUD SCREW 4.76	
51	S11380001	1	センタン"カ"イト"ツキ"テ	POINT GUIDE UNIVERSAL	
53	S11381000	1	Rクランプ"タイB	(R) CLAMP BRACKET (B)	
54	105173004	2	シメネシ"4.76	SCREW 4.76	
55	S11382001	2	Rクランプ"アンナイシ"ク	(R) CLAMP GUIDE SHAFT	
56	014680622	2	アナトメネシ"4.37クホ"ミ	SET SCREW 4.37	
57	S11443000	4	フ"ツシユ6-10	BUSH (6-10)	
58	S11383000	1	Lクランプ"タイD	(L) CLAMP BRACKET (D)	
59	018501622	2	アナボ"ルト5X16	BOLT 5X16	
60	018501022	2	アナボ"ルト5X10	BOLT 5X10	
61	028050242	4	ハ"ネサ"カ"ネ2-5	SPRING WASHER 2-5	
62	S11385001	1	Lクランプ"ササエC	(L) CLAMP SUPPORT (C)	
63	105173004	2	シメネシ"4.76	SCREW 4.76	

E1. 布制御関係 / Cloth control system mechanism / Stoffführungsvorrichtung /
 Mécanisme de la système de contrôle du tissu / Mecanismo de la sistema de control de tela

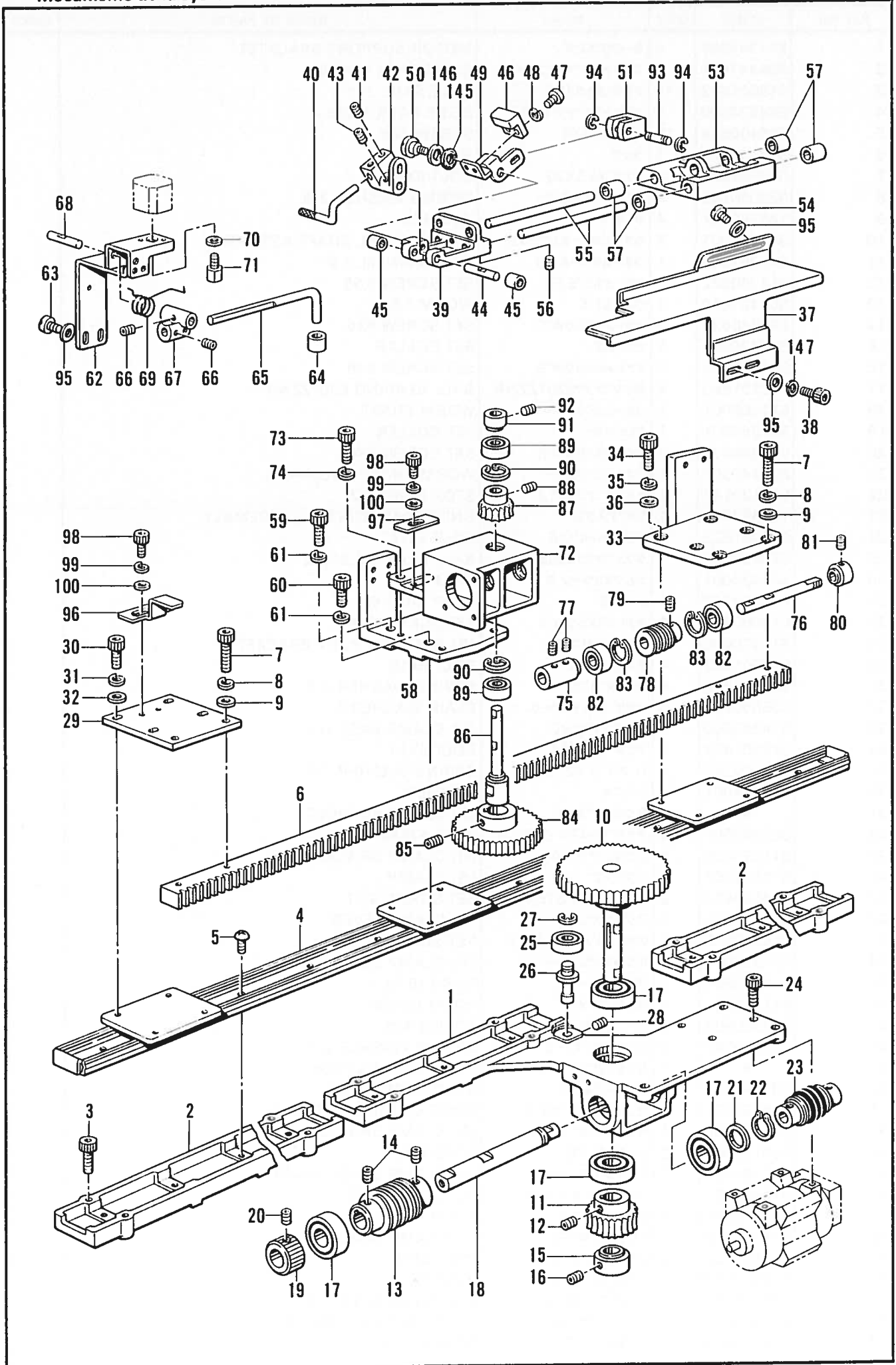

E1. 布制御関係 / Cloth control system mechanism / Stoffführungsvorrichtung /
 Mécanisme de la système de contrôle du tissu / Mecanismo de la sistema de control de tela

REF NO.	CODE	Q'TY	ヒンメイ	NAME OF PARTS	RMKS
64	S04404000	1	クランプヌノオサエ	CLAMP CLOTH PRESSER	
65	S11386001	1	アトクランプウデ	BACK CLAMP ARM	
66	014500522	3	アナトメネシ"5クホ"ミ	SET SCREW 5	
67	S04398001	1	クランプウデ"シテン	CLAMP ARM FUICRUM	
68	S04399001	1	クランプササエシ"ク	CLAMP SUPPORT SHAFT	
69	S04406001	1	クランプウデ"ハ"ネA	SPRING (A)	
70	S04402001	1	シリンダ"ヘッド"サ"カ"ネ	CYLINDER HEAD WASHER	
71	S04411001	1	Bクランプ"ヘッド"	(B) CLAMP HEAD	
72	S11387000	1	ハ"ルスモータ"イ	PULSE NOTOR BRACKET	
73	018501422	4	アナボ"ルト5X14	BOLT 5X14	
74	028050242	4	ハ"ネサ"カ"ネ2-5	SPRING WASHER 2-5	
75	S11388001	1	ハ"ルスモータシ"クツキ"テ	PULSE MOTOR SHAFT UNIVERSAL	
76	S11389001	1	ハ"ルスモータウオームシ"ク	PULSE MOTOR WORM SHAFT	
77	014680622	4	アナトメネシ"4.37クホ"ミ	SET SCREW 4.37	
78	S11215000	1	ウオームM1	WORM M1	
79	014710522	2	アナトメネシ"4.76クホ"ミ	SET SCREW 4.76	
80	S11391001	1	クランプウオームシ"クカラー	CLAMP WORM SHAFT COLLOR	
81	014680622	2	アナトメネシ"4.37クホ"ミ	SET SCREW 4.37	
82	070626800	2	タマシ"クウケ626ZZ	BALL BEARING 626ZZ	
83	048190242	2	トメワアナヨウC19	STOP RING C19	
84	S04451000	1	キ"ヤ1.5X40	GEAR 1.5X40	
85	014060632	2	アナトメ6X6クホ"ミ	SET SCREW 6X6	
86	S11392001	1	クランプキ"ヤシ"ク	CLAMP GEAR SHAFT	
87	S04452000	1	ウオームホイールM1	WORM WHEEL M1	
88	014060632	2	アナトメ6X6クホ"ミ	SET SCREW 6X6	
89	070698800	2	タマシ"クウケ698ZZ	BALL BEARING 698ZZ	
90	048190242	2	トメワアナヨウC19	STOP RING C19	
91	S11394001	1	クランプキ"ヤシ"クカラー	CLAMP GEAR SHAFT COLLOR	
92	014680622	2	アナトメネシ"4.37クホ"ミ	SET SCREW 4.37	
93	S11377001	2	Rクランプ"ピン	PIN	
94	048025342	4	トメワE2.5	STOP RING E2.5	
95	148847001	6	サ"カ"ネ	WASHER	
96	S11395001	1	ト"ク"A	DOG (A)	
97	S11396001	1	ト"ク"B	DOG (B)	
98	018400632	3	アナボ"ルト4X6	BOLT 4X6	
99	028040242	3	ハ"ネサ"カ"ネ2-4	SPRING WASHER 2-4	
100	025040232	3	ヒラサ"カ"ネチユウ4	PLAIN WASHER 4	
145	S14183009	1	フェルト	FELT	
146	S14184001	1	ファイハ"ーワッシヤ	WASHER	
147	028050242	2	ハ"ネサ"カ"ネ2-5	SPRING WASHER 2-5	

E1. 布制御関係 / Cloth control system mechanism / Stoffführungsvorrichtung /
 Mécanisme de la système de contrôle du tissu / Mecanismo de la sistema de control de tela

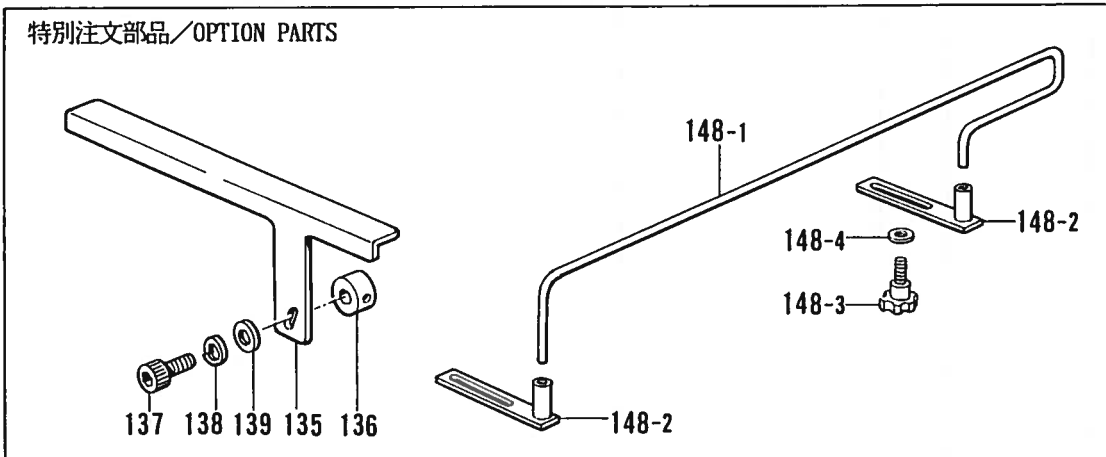
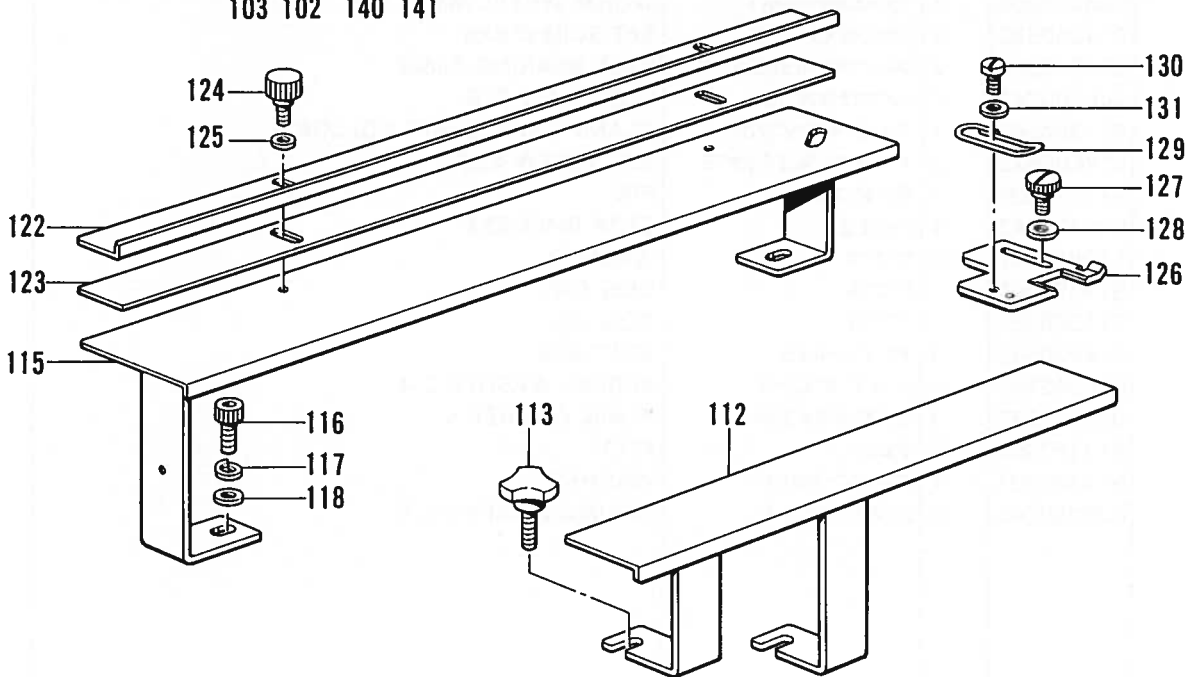
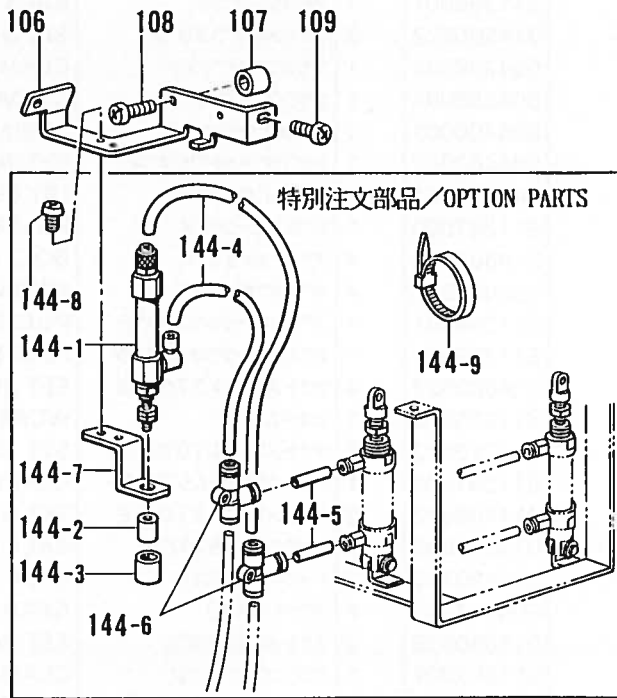
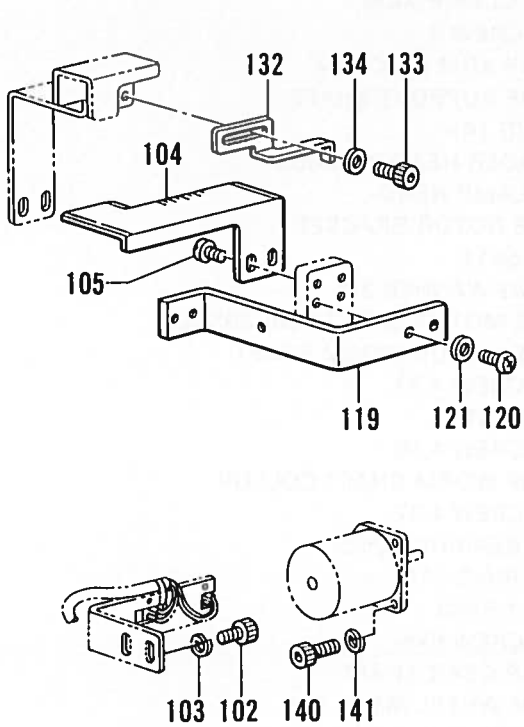

E1. 布制御関係 / Cloth control system mechanism / Stoffführungsvorrichtung /
 Mécanisme de la système de contrôle du tissu / Mecanismo de la sistema de control de tela

REF.NO.	CODE	Q'TY	ヒンメイ	NAME OF PARTS	RMKS
102	018400632	2	アナホ"ルト4X6	BOLT 4X6	
103	028040242	2	ハ"ネサ"ガ"ネ2-4	SPRING WASHER 2-4	
104	S11384001	1	Lクランプ"ササエA	(L) CLAMP SUPPORT (A)	
105	105173004	2	シメネジ"4.76	SCREW 4.76	
106	S11398001	1	シリンダ"フ"ラケットA	CYLINDER BRACKET (A)	
107	158653000	1	シリンダ"カラー	CYLINDER COLLAR	
108	062711412	1	ナヘ"コ476-32X14	SCREW 476X14	
109	062710812	1	ナヘ"コ476-32X8	SCREW 476X8	
112	S11400009	1	ミゴ"ロササエウシロ	CLOTH PUT BASE SUPPORT REAR	
113	S01856000	2	ツマミホ"ルトM6X20	BOLT M6X20	
115	S11399009	1	ミゴ"ロササエ	CLOTH PUT BASE SUPPORT	
116	018081622	2	アナホ"ルト8X16	BOLT 8X16	
117	028080242	2	ハ"ネサ"ガ"ネ2-8	SPRING WASHER 2-8	
118	025080232	2	ヒラサ"ガ"ネチユウ8	PLAIN WASHER 8	
119	S11444000	1	Lクランプ"ササエイタ	(L) CLAMP SUPPORT PLATE	
120	105173004	2	シメネジ"4.76	SCREW 4.76	
121	148847001	2	サ"ガ"ネ	WASHER	
122	S00463101	1	ミゴ"ロガ"イト"	CLOTH PUT BASE GUIDE	
123	S00628000	1	ホ"ウシシコ"ムG	RUBBER (G)	
124	S00655000	2	ツマミネジ" M4	SCREW M4	
125	025040233	2	ヒラサ"ガ"ネチユウ4	PLAIN WASHER 4	
126	S00642001	1	タテシ"ヨウキ"	RULER	
127	115166001	2	タ"ンネジ"4.37	STUD SCREW 4.37	
128	146549001	2	オクリタ"イカクコ"マアテイタ	SLIDE BLOCK PLATE	
129	S00997001	1	ヌノガ"イト"	CLOTH GUIDE	
130	107419002	2	シメネジ"4.37	SCREW 4.37	
131	025680232	2	ヒラサ"ガ"ネチユウ4.37	PLAIN WASHER 4.37	
132	S11401001	1	レテ"イヨウガ"イト"	READY GUIDE	
133	018400532	2	アナホ"ルト4X5	BOLT 4X5	
134	025040232	2	ヒラサ"ガ"ネチユウ4	PLAIN WASHER 4	
140	018401222	3	アナホ"ルト4X12	BOLT 4X12	
141	028040242	3	ハ"ネサ"ガ"ネ2-4	SPRING WASHER 2-4	
<オプション / OPTION PARTS >					
135	S11402001	1	ヌノガ"イト"ハ"	CLOTH GUIDE BAR	
136	159436001	1	セツトカラー	SET COLLAR	
137	018061622	1	アナホ"ルト6X16	BOLT 6X16	
138	028060242	1	ハ"ネサ"ガ"ネ2-6	SPRING WASHER 2-6	
139	025060232	1	ヒラサ"ガ"ネチユウ 6	PLAIN WASHER 6	
144	183549001	1	ホ"イントシリンダ"クミ	POINT CYLINDER ASSEMBLY	
144-1	S11428000	1	エア"シリンダ"10X15クミ	AIR CYLINDER ASSEMBLY (10X15)	
144-2	S07963001	1	ツクミスシリンダ"ヘッド"	CYLINDER HEAD	
144-3	S05356000	1	ホ"タンオサエA	BUTTON PRESSER (A)	
144-4	S11440003	2	エア"チューブ"	AIR TUBE	
144-5	S09192001	2	チューブ"	OIL TUBE	
144-6	S01202000	2	チース"	T-JOINT	
144-7	S11419001	1	シリンダ"フ"ラケットB	CYLINDER BRACKET	
144-8	062680612	2	ナヘ"コ437-40X6	SCREW 437X6	
144-9	S04557000	2	ハンタイPLTIM	BAND PLTIM	
148	183697009	1	ホシ"ヨハ"ークミ	SUPPORT BAR ASSEMBLY	
148-1	S15520009	1	ホシ"ヨハ"ー	SUPPORT BAR	
148-2	S15521001	2	ハ"ーササエ	BAR SUPPORT	
148-3	S05438100	4	ホ"ウルシメネジ"	SCREW	
148-4	025080232	4	ヒラサ"ガ"ネチユウ8	PLAIN WASHER 8	

F1. 動力台関係 / Power table / Motorgestell /
 Mécanisme du plateau de la machine / Mecanismo de la mesa de la máquina

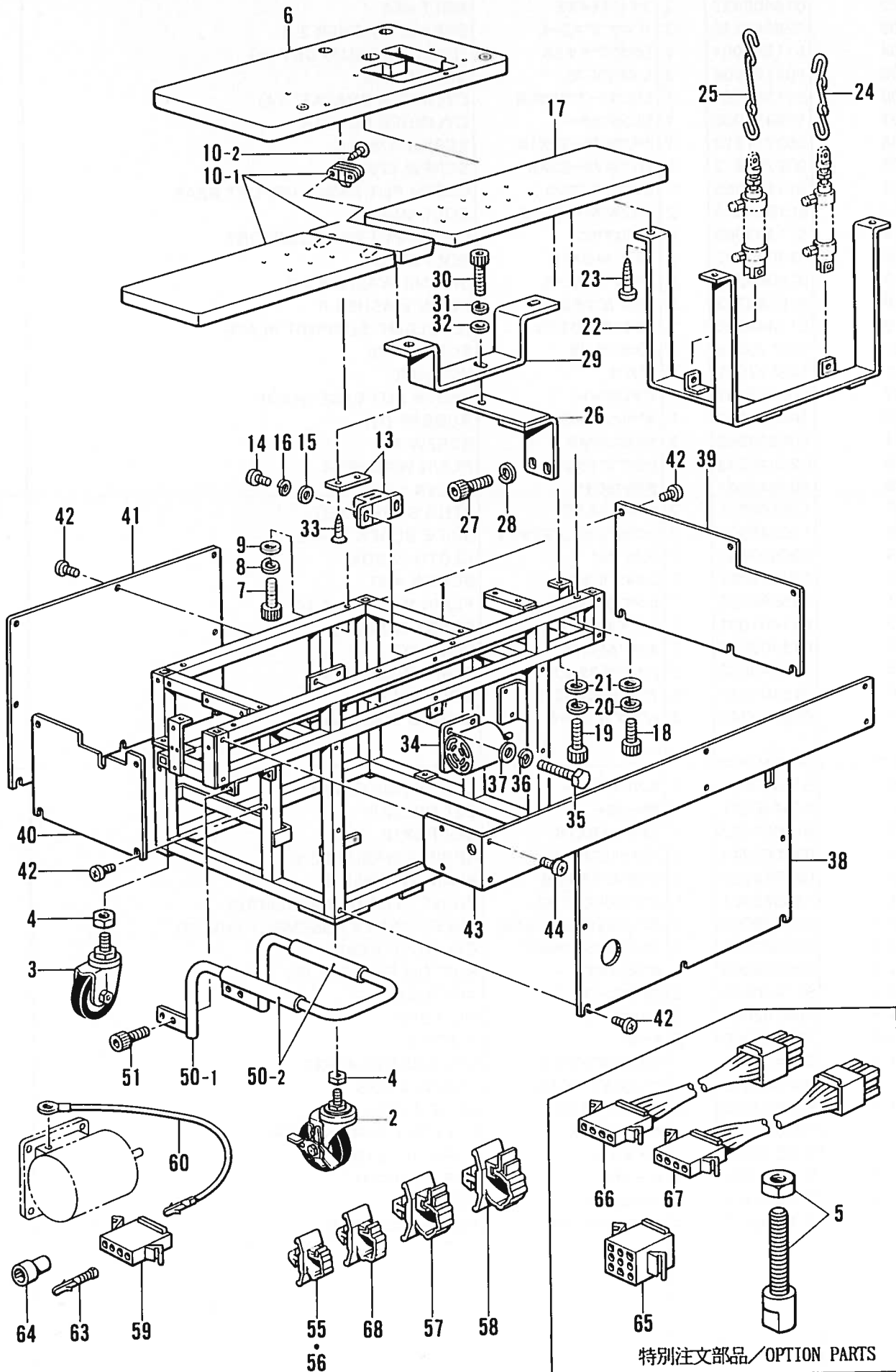

F1. 動力台関係 / Power table / Motorgestell /

Mécanisme du plateau de la machine / Mecanismo de la mesa de la máquina

REF. NO.	CODE	Q.TY	ヒンメイ	NAME OF PARTS	RMKS
1	S11403009	1	BAS510フレーム	BAS 510 FRAME	
2	S00403100	2	キャスター	CASTER	
3	S12225000	2	キャスター100	CASTER 100	
4	021200203	4	ナット2シユ20	NUT 20	
6	S11404009	1	テーブルA	TABLE (A)	
7	018082022	4	アナホ"ルト8X20	BOLT 8X20	
8	028080242	4	ハ"ネサ"カ"ネ2-8	SPRING WASHER 2-8	
9	025080232	4	ヒラサ"カ"ネチユウ8	PLAIN WASHER 8	
10	S11405009	1	テーブルBクミ	TABLE (B) ASSEMBLY	
10-1	S04929000	2	レント"ウチヨウハン	HINGE	
10-2	034362006	8	+ サラモクネシ" 3.5X20	SCREW 3.5X20	
13	S09448000	1	マグ"ネット	MAGNET	
14	062300616	2	ナヘ"コM3X6	SCREW M3X6	
15	025030233	2	ヒラサ"カ"ネチユウ3	PLAIN WASHER 3	
16	028030243	2	ハ"ネサ"カ"ネ2-3	SPRING WASHER 2-3	
17	S11406009	1	テーブルC	TABLE (C)	
18	018082022	4	アナホ"ルト8X20	BOLT 8X20	
19	018082522	4	アナホ"ルト8X25	BOLT 8X25	
20	028080242	8	ハ"ネサ"カ"ネ2-8	SPRING WASHER 2-8	
21	025080232	8	ヒラサ"カ"ネチユウ8	PLAIN WASHER 8	
22	S00405001	1	シリンダ"ーササエD	CYLINDER SUPPORT (D)	
23	101125000	3	マルモクネシ"6.2X32	SCREW 6.2X32	
24	S00406101	1	クサリクミ2	CHAIN 2	
25	S00407101	1	クサリクミ4	CHAIN 4	
26	S11407001	1	テーブル"ルササエA	TABLE SUPPORT (A)	
27	018061622	2	アナホ"ルト6X16	BOLT 6X16	
28	028060242	2	ハ"ネサ"カ"ネ2-6	SPRING WASHER 2-6	
29	S11408001	1	テーブル"ルササエAB	TABLE SUPPORT (B)	
30	018062222	1	アナホ"ルト6X22	BOLT 6X22	
31	028060242	1	ハ"ネサ"カ"ネ2-6	SPRING WASHER 2-6	
32	025060232	1	ヒラサ"カ"ネチユウ 6	PLAIN WASHER 6	
33	034311302	2	+ サラモクネシ"3.1X13	SCREW 3.1X13	
34	*	1	モータ	MOTOR	
35	017063002	4	ボ"ルト6X30	BOLT 6X30	
36	028060242	4	ハ"ネサ"カ"ネ2-6	SPRING WASHER 2-6	
37	025060232	4	ヒラサ"カ"ネチユウ 6	PLAIN WASHER 6	
38	S11409009	1	マイカハ"ーA	FRONT COVER (A)	
39	S11410009	1	ソクメンカハ"ーR	FRAME SIDE COVER (R)	
40	S11417109	1	ソクメンカハ"ーL	FRAME SIDE COVER (L)	
41	S11411009	1	ハイメンカハ"ー	REAR COVER	
42	008400604	26	+トラスコ4X6	SCREW 4X6	
43	S11412009	1	フロントカハ"ーウエ	FRONT COVER UPPER	
44	008400604	8	+トラスコ4X6	SCREW 4X6	
50	S13086001	1	ミゴ"ロタ"イタミ	CLOTH PUT BASE ASSEMBLY	
50-1	S00485001	1	ミゴ"ロタ"イ	CLOTH PUT BASE	
50-2	S11476000	2	スヘ"リト"メ	BRACE	
51	018081222	4	アナホ"ルト8X12	BOLT 8X12	
55	150349001	3	コード"クランプ"10-L	CORD CLAMP 10-L	
56	150349001	1	コード"クランプ"10-L	CORD CLAMP 10-L	
57	S09141000	3	コード"クランプ"16-L	CORD CLAMP 16-L	
58	S09142000	9	コード"クランプ"20-L	CORD CLAMP 20-L	
59	S00603000	1	コネクタ4P	4P CONNECTOR	
60	S00614000	1	モータアースセン	MOTOR EARTH WIRE	
63	S03328000	3	ピンターミナルオスL	TERMINAL PIN (L)(MALE)	
64	*	1	ハイタンセツソ"クシ#5	NYLON CONNECTOR #5	
68	150357001	2	コード"クランプ"13-L	CORD CLAMP 13-L	

F1. 動力台関係 / Power table / Motorgestell /
 Mécanisme du plateau de la machine / Mecanismo de la mesa de la máquina

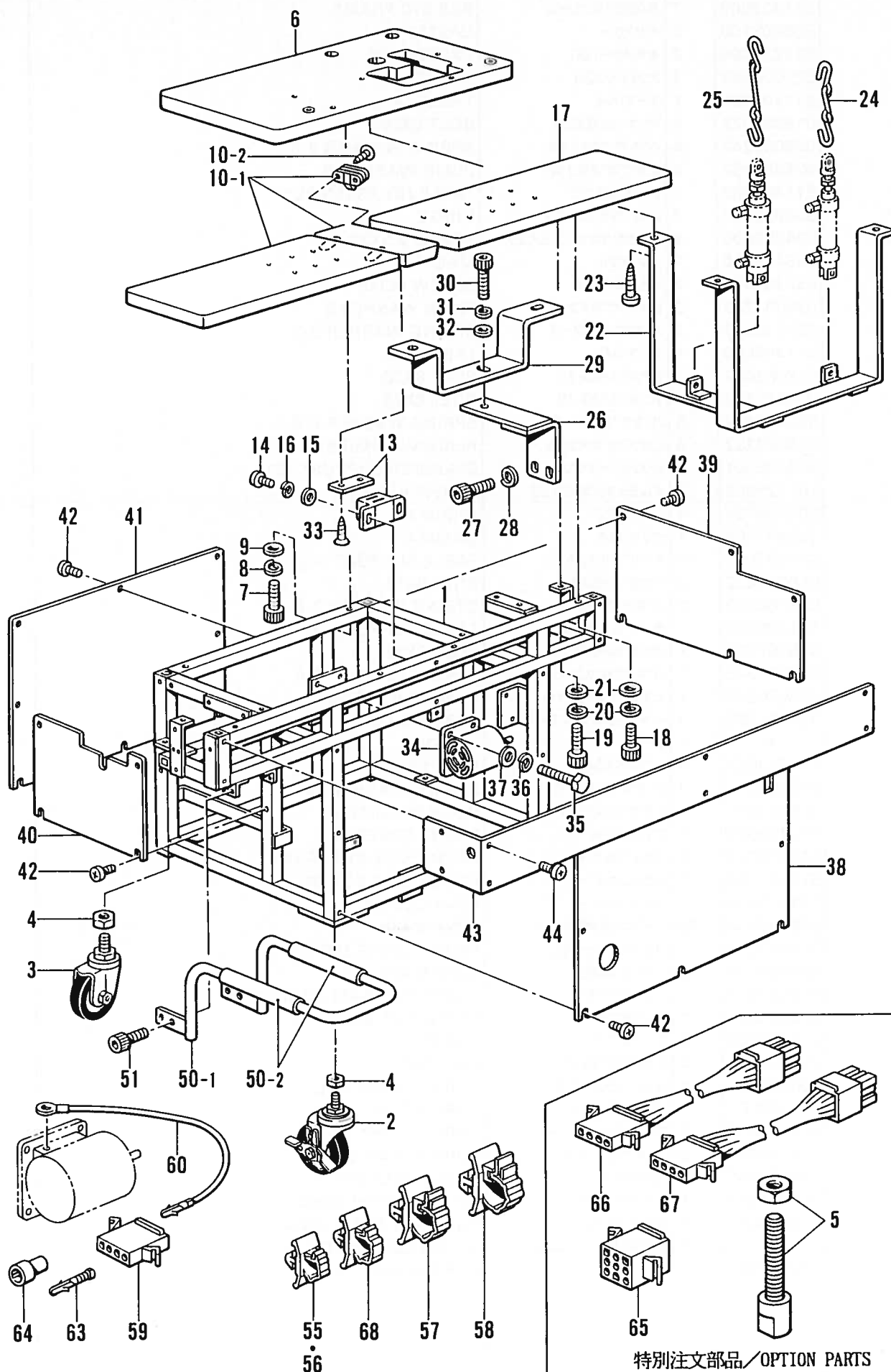

特別注文部品 / OPTION PARTS

F1. 動力台関係 / Power table / Motorgestell /
 Mécanisme du plateau de la machine / Mecanismo de la mesa de la máquina

REF NO.	CODE	Q'TY	ヒンメイ	NAME OF PARTS	RMKS
<オプション / OPTION PARTS >					
5	S11148001	4	チヨウセツネシ"クミ	ADJUST SCREW ASSEMBLY	
65	S11680000	1	コネクタ3191-09P	CONNECTOR (3191-09P)	
66	S11681000	1	220Vアダ"プタ	ADAPTER (220V)	
67	S11682000	1	380Vアダ"プタ	ADAPTER (380V)	

Z. 付属品関係 / Accessories / Zubehör / Accessoires / Accesorios

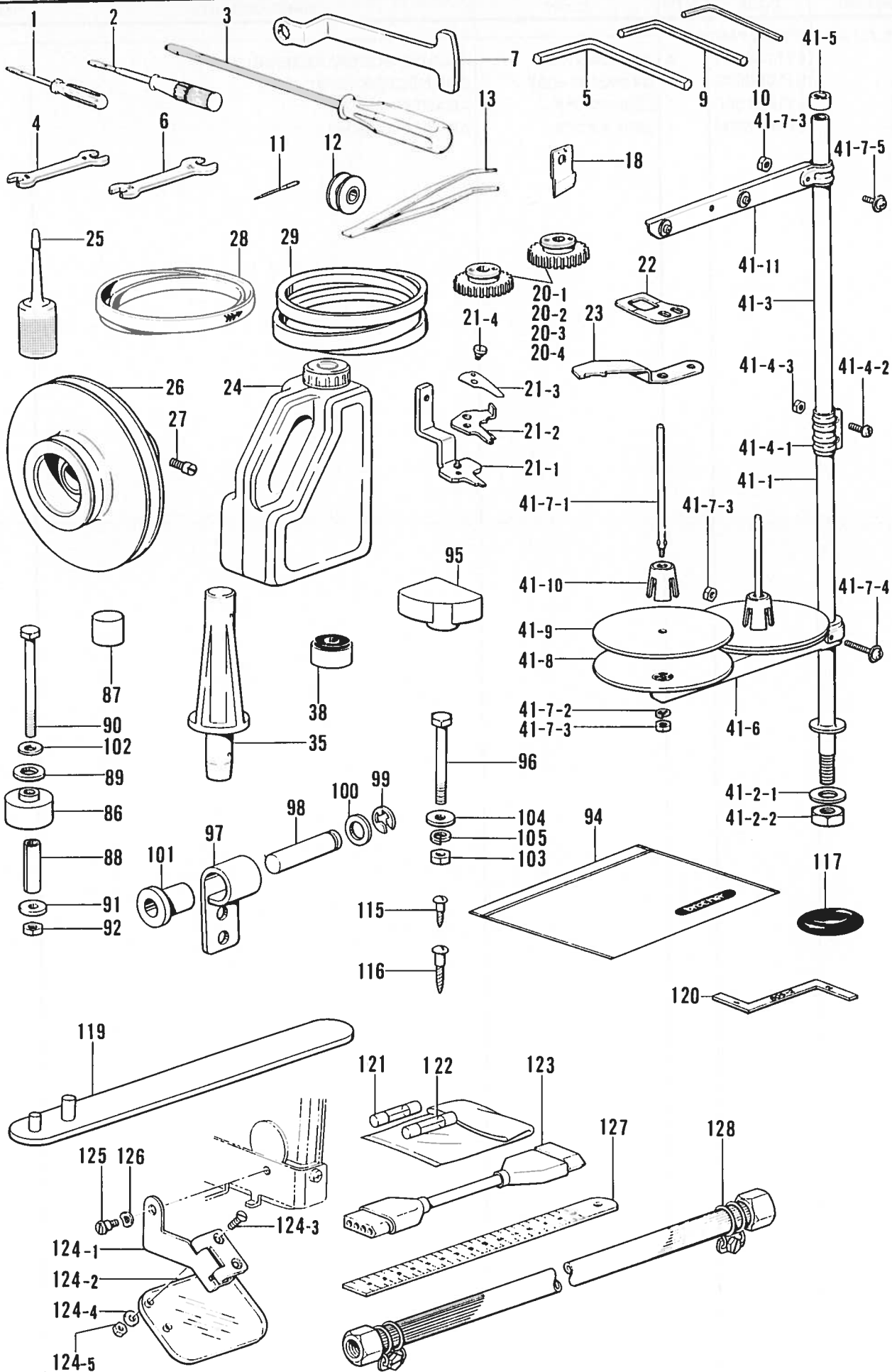

◎ 付属品の明細は変更することがあります。
 ◎ The details of included accessories are subject to change.
 ◎ Änderungen in der Aufstellung der Mitgelieferten Zubehöre sind vorbehalten.

◎ Les détails des accessoires inclus sont sujets a des changements.
 ◎ Los detalles de los accesorios incluidos pueden variar.

Z. 付属品関係 / Accessories / Zubehör / Accessoires / Accesorios

REF NO	CODE	Q'TY	ヒンメイ	NAME OF PARTS	RMKS
1	142443001	1	ネジ"マフシ1.9X52	SCREW DRIVER 1.9X52	
2	118837001	1	ネジ"マフシ3.4X70	SCREW DRIVER 3.4X70	
3	101572101	1	ネジ"マフシ5.5X190	SCREW DRIVER 5.5X190	
4	100887001	1	スハ°ナ8X9	SPANNER 8X9	
5	115157001	1	6カクホ"ウスハ°ナ6	HEXAGONAL WRENCH 6	
6	107780001	1	スハ°ナ10X12	SPANNER 10X12	
7	152765001	1	メガ"ネレンチ10	WRENCH 10	
9	150335001	1	6カクホ"ウスハ°ナ5	HEXAGONAL WRENCH 5	
10	142721001	1	6カクホ"ウスハ°ナ3	HEXAGONAL WRENCH 3	
11	S13594080	10	ミシンハリ1906#12	-----	
11	S13594090	10	-----	NEEDLE 1906 #14	
12	159158001	3	ホ"ビ"ン	BOBBIN	
13	117466000	1	ヒ°ンセツト	PINCETTE	
18	107200001	1	カツタ1/2	CUTTER 1/2	
20-1	141377000	1	チエンジ"キ"ヤ32	CHANGE GEAR 32	
20-2	141379000	1	チエンジ"キ"ヤ36	CHANGE GEAR 36	
20-3	141381000	1	チエンジ"キ"ヤ40	CHANGE GEAR 40	
20-4	141383000	1	チエンジ"キ"ヤ44	CHANGE GEAR 44	
21	S19824001	1	ハサミクミ	UPPER THREAD TRIMMER ASSEMBLY	
21-1	S19820001	1	ハサミDクミ	UPPER THREAD TRIMMER (D)ASSEMBLY	
21-2	S19822001	1	ハサミM	UPPER THREAD TRIMMER (M)	
21-3	S19823001	1	ハサミU	UPPER THREAD TRIMMER (U)	
21-4	141514001	1	ハサミタ"ンネシ"	STUD SCREW	
22	159276201	1	シタイトコテイハ	FIXED KNIFE	
23	159274001	1	シタイトイト"ウハ	MOVABLE KNIFE	
24	154702001	1	オイルタンク	OIL TANK	
25	S06701000	1	ホ°リオイラークミ	POLY OILER ASSEMBLY	
26	*	1	モータプ°ーリ	MOTOR PULLY	
27	105073001	2	アタマツキトメネシ"5.95	SCREW 5.95	
28	141711100	1	ヒラヘルト	BELT	
29	*	1	Vヘルト	V BELT	
35	159384009	1	トウフ"ササエマクラ	HEAD REST	
38	146254001	4	モータカンザ"	COLLAR	
41	S02762009	1	イトタテダ"イクミ2D	COTTON STAND ASSEMBLY 2D	
41-1	156112003	1	コラムハ°イフ°D	COLUMN PIPE (D)	
41-2	S02775001	1	ハ°イフ°ネシ"セツトA	PIPE SCREW SET (A)	
41-2-1	150206002	1	ヒラサ"カ"ネ16	PLAIN WASHER 16	
41-2-2	150191002	1	6カクナツト5/8	NUT 5/8	
41-3	150172003	1	コラムハ°イフ°	COLUMN PIPE	
41-4	150106003	1	コラムジ"ヨイントクミ	COLUMN JOINT ASSEMBLY	
41-4-1	150173003	1	コラムジ"ヨイント	COLUMN JOINT	
41-4-2	062501406	2	ナヘ"コ5X14	SCREW 5X14	
41-4-3	021500106	2	1シユナツト5	NUT 5	
41-5	150174000	1	コラムキヤツフ°	COLUMN CAP	
41-6	S02778002	1	スフ°ールホルタ"ー2	SPOOL HOLDER 2	
41-7	S02780001	1	スフ°ールネシ"セツト2	SPOOL SCREW SET 2	
41-7-1	150179002	2	スフ°ールシ"クB	SPOOL SHAFT (B)	
41-7-2	028050246	2	ハ"ネサ"カ"ネ2-5	SPRING WASHER 2-5	
41-7-3	021500106	4	1シユナツト5	NUT 5	
41-7-4	050503006	1	ナヘ"コヒラサ"5X30	WASHER SCREW 5X30	
41-7-5	050501406	1	ナヘ"コヒラサ"5X14	WASHER SCREW 5X14	
41-8	150180001	2	ウケサ"ラ	SPOOL STAND BASE	
41-9	150182000	2	スフ°ールマット	SPOOL MAT	
41-10	126863001	2	スフ°ールクツシヨ	SPOOL CUSHION	
41-11	S02786002	1	スレツト"ハンガ"ークミ2	THREAD HANGER ASSEMBLY 2	
86	158827009	4	ヘ"ツト"タ"イクツシヨ	BED BASE CUSHION (A)	
87	158828009	1	ヘ"ツト"タ"イクツシヨ	BED BASE CUAHION (B)	
88	159715001	4	スペ°ーサー6X25	SPACER 6X25	
89	159458009	4	ゴ"ムシート	RUBBER SHEET	
90	159910001	4	ホ"ルト6X75	BOLT 6X75	
91	115947001	2	サ"カ"ネ	WASHER	
92	021060102	4	ナツト1シユ6	NUT 6	

Z. 付属品関係 / Accessories / Zubehör / Accessoires / Accesorios

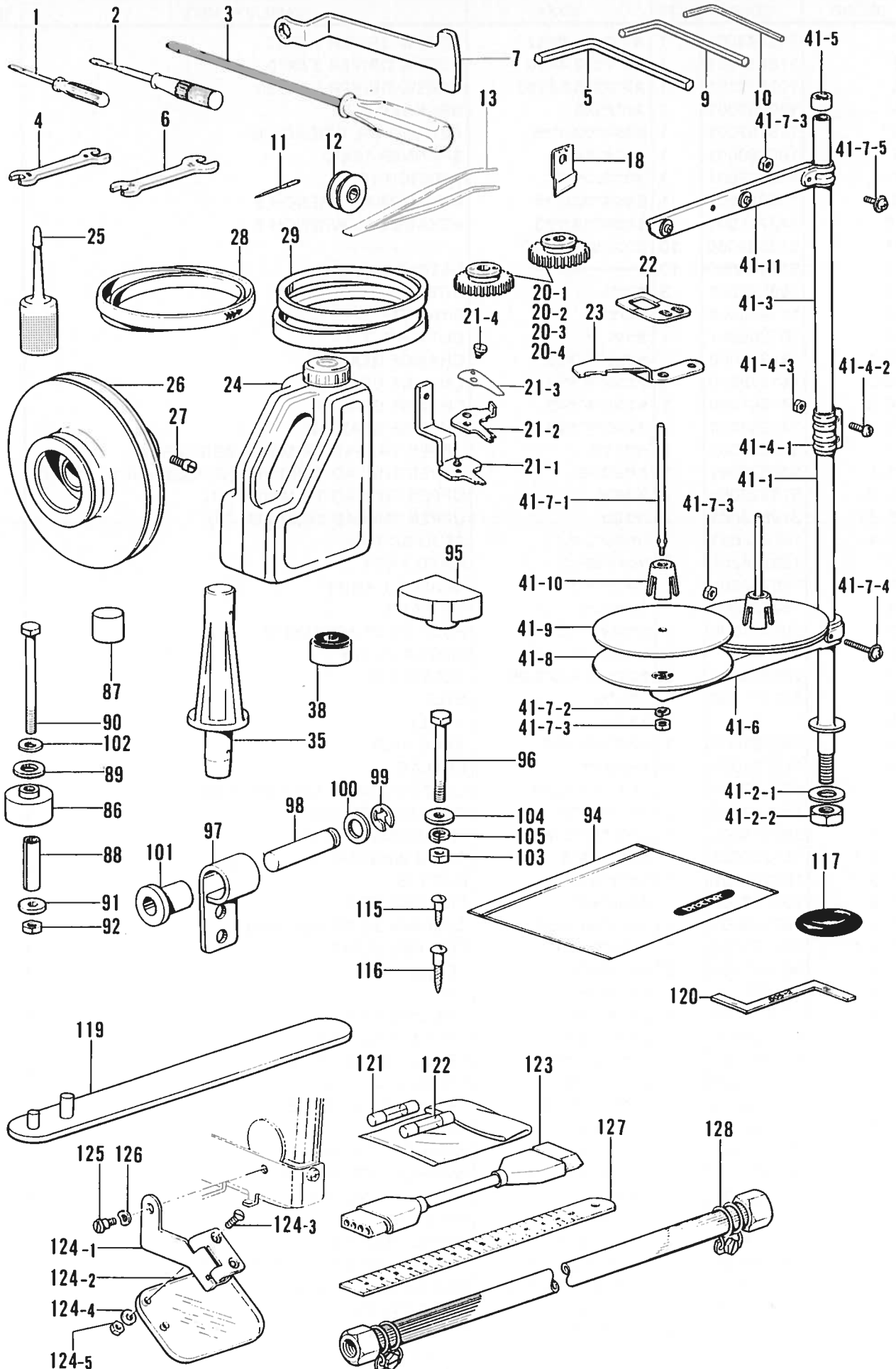

● 付属品の明細は変更することがあります。
 ● The details of included accessories are subject to change.
 ● Änderungen in der Aufstellung der Mitgelieferten Zubehöre sind vorbehalten.

● Les détails des accessoires inclus sont sujets à des changements.
 ● Los detalles de los accesorios incluidos pueden variar.

Z. 付属品関係 / Accessories / Zubehör / Accessoires / Accesorios

REF. NO.	CODE	Q'TY	ヒンメイ	NAME OF PARTS	RMKS
94	122991001	1	フックヒンホリフクロ	ACCESSORY BAG	
95	159454009	1	ヘットクッションF	BED CUSHION (F)	
96	017066002	2	ボルト6X60	BOLT 6X60	
97	158830001	2	ヒンジ	BED HINGE	
98	158831001	2	ヒンジピン	PIN	
99	048080342	2	トメフE8	STOP RING E8	
100	025100132	2	ヒラサカネシヨウ10	PLAIN WASHER 10	
101	158832009	2	ヒンジピンササエゴム	HINGE PIN SUPPORTER RUBBER	
102	141400001	2	サカネ	WASHER	
103	021060102	2	ナット1シユ6	NUT 6	
104	025060332	4	ヒラサカネタイ6	PLAIN WASHER 6	
105	028060242	2	ハネサカネ2-6	SPRING WASHER 2-6	
115	101118001	1	マルモクネジ4.5X20	SCREW 4.5X20	
116	101125000	1	マルモクネジ6.2X32	SCREW 6.2X32	
117	120448001	1	ゴムワ	RUBBER RING	
119	S12609001	1	ハネハスシクミ	SPRING GUIDE ASSEMBLY	
120	S13597001	1	テアイケージ805-2	TIMING GAUGE 805-2	
121	215769001	2	カンヒユース3A	FUSE 3A	
122	153242000	1	ヒユース6A	FUSE (6A)	
123	S01204000	1	ワンペアダプタ	ONE PEDAL ADAPTER	
124	S11414001	1	アイガードクミ	EYE GUARD ASSEMBLY	
124-1	S11415001	1	アイガードチヨウハンクミ	EYE GUARD HINGE ASSEMBLY	
124-2	143966001	1	アイガード	EYE GUARD	
124-3	S01700001	2	マルサラネジ3.18X7	SCREW 3.18X7	
124-4	025030232	2	ヒラサカネチユウ3	PLAIN WASHER 3	
124-5	021660102	2	ナット1シユ3.18	NUT 3.18	
125	145370001	1	タンネジ3.57	STUD SCREW 3.57	
126	130502001	1	ナミカタハネサカネ	SPRING WASHER	
127	S11466000	1	コウシヤク	SCALE	
128	149796001	1	ゴムホースカナクツキ	AIR TUBE WITH CONNECTOR	

仕様別部品一覧表/DIFFERENT PARTS LIST/ZUBEHÖRLISTE/
LISTE DES PIÈCES ACCESSOIRES/LISTA DE PIEZAS ACCESORIAS

REF.NO.	サブクラス SUB CLASS ヒンメイ PARTS	200V 50HZ コクナイヨウ FOR DEMETIC	200V 60HZ コクナイヨウ FOR DOMESTIC	200V 50.60HZ コクナイヨウ FOR DOMESTIC	220V 60HZ ユシユツヨウ FOR EXPORT	
D1-6	ブレーカ200V BREAKER 200V	S00594100	←	←	←	
E1-37	Rクランプササエ (R) CLAMP SUPPORT	S14203001	←	←	←	
E1-49	センタンガイドレバー POINT GUIDE LEVER	S11379001	←	←	←	
F1-34	モータ MOTOR	159812001	←	S10405000	159812005	

REF.NO.	サブクラス SUB CLASS ヒンメイ PARTS	380V 50HZ ユシユツヨウ FOR EXPORT	380V 50HZ ユシユツヨウ FOR EXPORT (TOP FEED)	415V 50HZ ユシユツヨウ FOR EXPORT		
D1-6	ブレーカ380V BREAKER 380V	S00609100	←	←		
E1-37	Rクランプササエ (R) CLAMP SUPPORT	S14203001	S14204001	S14203001		
E1-49	センタンガイドレバー POINT GUIDE LEVER	S11379001	S11485001	S11379001		
F1-34	モータ MOTOR	159812005	←	159812004		
F1-64	ヘイタンセツゾクシ#5 NYLON CONNECTOR #5	217169000	←	-----		

仕掛別部品一覧表/DIFFERENT PARTS LIST/ZUBEHÖRLISTE/
LISTE DES PIÈCES ACCESSOIRES/LISTA DE PIEZAS ACCESORIAS

REF. NO.	部品 PARTS	サブクラス SUB CLASS	60HZ コナ137 FOR DOMESTIC	50HZ コナ137 FOR DOMESTIC	50,60HZ コナ137 FOR DOMESTIC
Z-26	モーター03600				S14072001
Z-26	モーター03200		159386001	159634001	
Z-29	VベルトM27 (コナ2)		S18707027		S18707027
Z-29	VベルトM28			S18707028	
Z-29	VベルトM29			S18707029	

REF. NO.	部品 PARTS	サブクラス SUB CLASS	60HZ コナ137 FOR EXPORT	50HZ コナ137 FOR EXPORT	50HZ コナ137 FOR EXPORT BOTTOM FEED
Z-26	MOTOR PULLEY 3600		159387001	159633001	
Z-29	V BELT M WHITE (M27) (QTY:1)		S18707027		
Z-29	V BELT M WHITE (M28)		S18707028		
Z-29	V BELT M WHITE (M30)			S18707030	

ゲージ部品一覧表/GAUGE PARTS LIST/LEHRENLISTE/
LIST DES PIÈCES D'ECARTEMENT/LISTA DE PIEZAS CALIBRADORAS

針数 Number of Stitches	チェンジヤル Change Gear L	チェンジヤル Change Gear R	針数 Number of Stitches	チェンジヤル Change Gear L	チェンジヤル Change Gear R
347	(54)141388-000	(22)141372-001	127	(36)141375-000	(40)141381-000
306	(52)141387-000	(24)141373-001	114	(34)141376-000	(42)141382-000
271	(50)141386-000	(26)141374-000	103	(32)141377-000	(44)141383-000
242	(48)141385-000	(28)141375-000	92	(30)141376-000	(46)141384-000
216	(46)141384-000	(30)141376-000	82	(28)141375-000	(48)141385-000
184	(44)141383-000	(32)141377-000	73	(26)141374-000	(50)141386-000
174	(42)141382-000	(34)141378-000	65	(24)141373-001	(52)141387-000
157	(40)141381-000	(36)141379-000	58	(22)141372-001	(54)141388-000
141	(38)141380-000	(38)141380-000			

回転数別モータープーリーとVベルト組合せ
MOTOR PULLEY AND V-BELT SELECTION/AUSWAHL DER RIEMENSCHLEIBEN UND ANTRIEBSRIEMEN/
CHOIX DE LA POULIE DE WOTEUR ET DES COURROIES TRAPEZOIDALES/
ELECCION DE POLEA DE MOTOR Y CORREA TRAPEZOIDAL

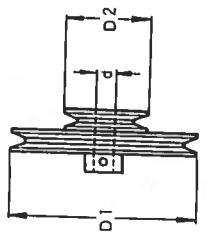

回転数 Machine Speed	周波数 Frequency	モータープーリー Motor Pulley		高速Vベルト(インチ) High Speed V-belt	低速Vベルト(インチ) Low Speed V-belt
		外径・内径 Outside Inside Diameter	穴径 Core Parts No.		
4000	50 Hz	D1=157.5 D2= 65.3	d=14 159632-001	S18707-031 (M31)	S18707-028 (M28)
		D1=132.2 D2= 51.7	d=14 159385-001	S18707-028 (M28)	S18707-027 (M27)
	60 Hz	D1=142.4 D2= 64.0	d=14 159633-001	S18707-030 (M30)	S18707-028 (M28)
		D1=119.5 D2= 54.1	d=16 159387-001	S18707-028 (M28)	S18707-027 (M27)
3200	50 Hz	D1=127.2 D2= 63.2	d=14 159634-001	S18707-029 (M29)	S18707-028 (M28)
		D1=106.9 D2= 56.8	d=16 159386-001	S18707-027 (M27)	S18707-027 (M27)
	60 Hz	D1= 91.5 D2= 56.8	d=14 159388-001	S18707-027 (M27)	S18707-027 (M27)
		D1= 91.5 D2= 56.8	d=16 159395-001	S18707-028 (M28)	S18707-027 (M27)
2800	60 Hz	D1= 91.5 D2= 56.8	d=14 159388-001	S18707-027 (M27)	S18707-027 (M27)
		D1= 91.5 D2= 56.8	d=16 159395-001	S18707-028 (M28)	S18707-027 (M27)

回転数別モータープーリーとVベルト組合せ
 MOTOR PULLEY AND V-BELT SELECTION/AUSWAHL DER RIEMENSCHLEIBEN UND ANTRIEBSRIEMEN/
 CHOIX DE LA POULIE DE WOTEUR ET DES COURROIES TRAPEZOIDALES/
 ELECCION DE POLEA DE MOTOR Y CORREA TRAPEZOIDAL

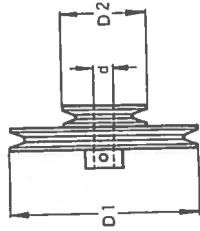

REF. NO.	部品名 PARTS	サブクラス SUB CLASS	60HZ エクスポート FOR DOMESTIC	50HZ エクスポート FOR DOMESTIC	50.60HZ エクスポート FOR DOMESTIC
Z-26	モーター-J3800		S14072001
Z-26	モーター-J3200		159386001	159634001
Z-29	VベルトM27 (M27) (J22x2)		S18707027	S18707027
Z-29	VベルトM28 (M28)		S18707028
Z-29	VベルトM29 (M29)		S18707029

REF. NO.	部品名 PARTS	サブクラス SUB CLASS	60HZ エクスポート FOR EXPORT	50HZ エクスポート FOR EXPORT	50HZ エクスポート FOR EXPORT (BOTTOM FEED)
Z-26	モータープーリー MOTOR PULLEY 3600		159387001	159633001	←
Z-29	VベルトM白色 (M27) (CITY-1)		S18707027
Z-29	VベルトM白色 (M28)		S18707028	←	←
Z-29	VベルトM白色 (M30)		S18707030	←

ゲージ部品一覧表 / GAUGE PARTS LIST / LEHRENLISTE /
 LIST DES PIÈCES D'ECARTEMENT / LISTA DE PIEZAS CALIBRADORAS

計数 Number of Stitches	チェンジギヤL Change Gear L	チェンジギヤR Change Gear R	針数 Number of Stitches	チェンジギヤL Change Gear L	チェンジギヤR Change Gear R
347	(54)141386-000	(22)141372-001	127	(36)141379-000	(40)141381-000
366	(52)141387-000	(24)141373-001	114	(34)141378-000	(42)141382-000
271	(50)141386-000	(26)141374-000	103	(32)141377-000	(44)141383-000
242	(48)141385-000	(28)141375-000	92	(30)141376-000	(46)141384-000
216	(46)141384-000	(30)141376-000	82	(28)141375-000	(48)141385-000
184	(44)141383-000	(32)141377-000	73	(26)141374-000	(50)141386-000
174	(42)141382-000	(34)141378-000	65	(24)141373-001	(52)141387-000
157	(40)141381-000	(36)141379-000	58	(22)141372-001	(54)141388-000
141	(38)141380-000	(38)141380-000			

回転数 Machine Speed	周波数 Frequency	モータープーリー Motor Pulley			高速Vベルト(インチ) High Speed V-belt	低速Vベルト(インチ) Low Speed V-belt
		外径・内径 Outside Inside Diameter	穴径 Core	部品コード Parts No.		
4000	50 Hz	D1=157.5 D2= 65.3	d=14	159632-001	S18707-031 (M31)	S18707-021 (M21)
		D1=132.2 D2= 51.7	d=14	159385-001 S00397-001	S18707-028 (M28)	S18707-027 (M27)
3600	50 Hz	D1=142.4 D2= 64.0	d=14 d=15.88	159633-001 S00392-001	S18707-030 (M30)	S18707-028 (M28)
		D1=119.5 D2= 54.1	d=16	S01242-001 S00393-001	S18707-028 (M28)	S18707-027 (M27)
3200	50 Hz	D1=127.2 D2= 63.2	d=14 d=15.88	159634-001 S00394-001	S18707-028 (M28)	S18707-028 (M28)
		D1=106.9 D2= 56.8	d=16	S01944-001 159386-001	S18707-027 (M27)	S18707-027 (M27)
2800	60 Hz	D1= 91.5 D2= 56.8	d=14	S12554-001	S18707-028 (M28)	S18707-027 (M27)

索引/INDEX/VERZEICHNIS/
INDEX/INDICE

CODE	REF.NO.	PAGE
S00313009	A1 - 101	52
S00403100	F1 - 2	74
S00405001	F1 - 22	74
S00406101	F1 - 24	74
S00407101	F1 - 25	74
S00463101	E1 - 122	72
S00485001	F1 - 50-1	74
S00490000	A1 - 28	50
S00594100	D1 - 6	62
S00603000	F1 - 59	74
S00609100	D1 - 6	62
S00614000	F1 - 60	74
S00628000	E1 - 123	72
S00635001	D1 - 62	64
S00642001	E1 - 126	72
S00655000	E1 - 124	72
S00793001	Q - 12	32
S00794001	Q - 14	32
S00862000	C - 36	8
S00875001	A - 109-1	4
S00901001	W - 42	48
S00902001	W - 43	48
S00903001	W - 44	48
S00996001	W - 38-1	48
S00997001	E1 - 129	72
S01009101	A - 99	4
S01047001	R - 13	34
S01109001	N - 17	30
S01143001	B - 5-2	6
S01202000	C1 - 20	56
	C1 - 6-6	56
	C1 - 60	60
	E1 - 144-6	72
S01204000	Z - 123	80
S01213000	C1 - 24	56
S01224000	A - 109-2	4
S01236001	J - 23	20
S01265001	A1 - 43	50
S01287009	T - 1	42
S01288003	T - 1-1	42
S01290001	T - 1-2	42
S01291001	T - 1-14	42
S01292001	T - 1-3	42
S01293001	T - 1-16	42
S01294001	T - 1-7	42
S01304001	D - 17-2	10
S01319001	C - 27	8
S01542000	C1 - 6-3	56
S01558001	S - 37	38
S01559001	V - 52	44
S01657001	C1 - 30	56
S01698001	E - 5	14
S01700001	Z - 124-3	80
S01856000	A1 - 55	50
	A1 - 66	52
	E1 - 113	72
S01870001	N - 11-1-3	30
	N - 11-2-3	30
S01961001	J - 42	20
S01962001	J - 56	22
S01964001	W - 38-2	48
S02762009	Z - 41	78
S02775001	Z - 41-2	78
S02778002	Z - 41-6	78
S02780001	Z - 41-7	78
S02786002	Z - 41-11	78
S02807001	M - 78	28

CODE	REF.NO.	PAGE
S03328000	F1 - 63	74
S03441001	E1 - 50	68
S04378000	A1 - 16	50
S04379001	A1 - 18	50
S04380000	A1 - 19	50
S04381000	A1 - 20	50
S04382000	A1 - 21	50
S04383000	A1 - 23	50
S04384001	D1 - 8	62
S04385000	D1 - 9	62
S04387001	A1 - 78	52
S04389001	A1 - 34	50
S04398001	E1 - 67	70
S04399001	E1 - 68	70
S04402001	E1 - 70	70
S04404000	E1 - 64	70
S04406001	E1 - 69	70
S04411001	E1 - 71	70
S04416001	A1 - 44	50
S04420009	A1 - 54	50
S04421009	A1 - 52	50
	A1 - 63	52
S04422000	A1 - 58	50
S04434001	E1 - 26	68
S04435001	E1 - 10	68
S04438001	E1 - 15	68
S04440001	E1 - 21	68
S04441000	E1 - 13	68
S04443000	E1 - 6	68
S04447001	E1 - 2	68
S04451000	E1 - 84	70
S04452000	E1 - 87	70
S04499001	D1 - 7	62
S04500001	D1 - 11	62
S04557000	C1 - 48	56
	D1 - 67	64
	E1 - 144-9	72
S04561000	D1 - 15	62
S04564000	D1 - 16	62
S04565001	D1 - 17	62
S04566001	D1 - 18	62
S04573000	D1 - 59	64
S04574000	E1 - 4	68
S04602001	D1 - 60	64
S04896000	C1 - 2	56
S04897000	C1 - 6-8	56
S04909000	C1 - 57-1	60
S04929000	F1 - 10-1	74
S05356000	E1 - 144-3	72
S05438100	E1 - 148-3	72
S06143000	C1 - 47	56
S06621001	C1 - 43	56
S06622001	C1 - 40	56
S06701000	Z - 25	78
S07849009	U - 1-1	42
S07850001	U - 1-2	42
S07851001	U - 1-5	42
S07852000	U - 1-15	42
S07876001	R - 16	34
S07959001	E1 - 38	68
S07963001	E1 - 144-2	72
S08030000	D1 - 70-1-4	66
S08038000	D1 - 70-1-3	66
S08105000	D1 - 2	62
S09141000	F1 - 57	74
S09142000	A1 - 100	52
	F1 - 58	74

CODE	REF.NO.	PAGE
S09188100	C1 - 6-1	56
S09189100	C1 - 6-2	56
S09192001	C1 - 49	56
	C1 - 6-7	56
	E1 - 144-5	72
S09448000	F1 - 13	74
S09477001	N - 11-1-3-1	30
	N - 11-2-3-1	30
S09566001	R - 79	36
S09610000	C1 - 26	56
S10405000	F1 - 34	74
S10543009	D1 - 46	62
S10544009	D1 - 47	62
S11148001	F1 - 5	76
S11215000	E1 - 78	70
S11309001	E - 12	14
S11341000	A1 - 1	50
S11342000	A1 - 3	50
S11343001	A1 - 6	50
S11344009	A1 - 7	50
S11345001	A1 - 8	50
S11348001	A1 - 14	50
S11349009	A1 - 35	50
S11350009	A1 - 36	50
S11353001	A1 - 59	50
S11354001	A1 - 65	52
S11355009	A1 - 69	52
S11357001	A1 - 76	52
S11359001	A1 - 85	52
S11360001	A1 - 87	52
S11363001	C1 - 6	56
S11365000	C1 - 51	56
S11366001	E1 - 1	68
S11367000	E1 - 11	68
S11368001	E1 - 18	68
S11369001	E1 - 19	68
S11370000	E1 - 29	68
S11373000	E1 - 39	68
S11374001	E1 - 40	68
S11375001	E1 - 42	68
S11376001	E1 - 44	68
S11377001	E1 - 93	70
S11378001	E1 - 46	68
S11379001	E1 - 49	68
S11380001	E1 - 51	68
S11381000	E1 - 53	68
S11382001	E1 - 55	68
S11383000	E1 - 58	68
S11384001	E1 - 104	72
S11385001	E1 - 62	68
S11386001	E1 - 65	70
S11387000	E1 - 72	70
S11388001	E1 - 75	70
S11389001	E1 - 76	70
S11391001	E1 - 80	70
S11392001	E1 - 86	70
S11394001	E1 - 91	70
S11395001	E1 - 96	70
S11396001	E1 - 97	70
S11398001	E1 - 106	72
S11399009	E1 - 115	72
S11400009	E1 - 112	72
S11401001	E1 - 132	72
S11402001	E1 - 135	72
S11403009	F1 - 1	74
S11404009	F1 - 6	74
S11405009	F1 - 10	74

CODE	REF.NO.	PAGE
S11406009	F1 - 17	74
S11407001	F1 - 26	74
S11408001	F1 - 29	74
S11409009	F1 - 38	74
S11410009	F1 - 39	74
S11411009	F1 - 41	74
S11412009	F1 - 43	74
S11414001	Z - 124	80
S11415001	Z - 124-1	80
S11417109	F1 - 40	74
S11418000	A1 - 70	52
S11419001	E1 - 144-7	72
S11420100	C1 - 1	56
S11421000	C1 - 5	56
S11422009	A1 - 49	50
S11423000	A1 - 50	50
S11425000	C1 - 21	56
S11427000	C1 - 23	56
S11428000	C1 - 9	56
	E1 - 144-1	72
S11430000	C1 - 10	56
S11431000	C1 - 14	56
S11434000	C1 - 15	56
S11436000	C1 - 16	56
S11438000	C1 - 17	56
S11440001	C1 - 50-1	56
S11440002	C1 - 50-2	56
	C1 - 50-3	56
S11440003	C1 - 50-10	56
	C1 - 50-4	56
	E1 - 144-4	72
S11440004	C1 - 50-5	56
S11440005	C1 - 50-6	56
S11440006	C1 - 50-7	56
S11440007	C1 - 50-8	56
S11440009	C1 - 50-9	56
S11440011	C1 - 50-11	56
S11442000	E1 - 45	68
S11443000	E1 - 57	68
S11444000	E1 - 119	72
S11466000	Z - 127	80
S11467009	B1 - 2	54
S11471001	A1 - 39	50
S11473101	B - 8-2	6
S11474101	B - 8-2-1	6
S11475000	C1 - 53	58
S11476000	F1 - 50-2	74
S11478001	J - 5	20
S11481000	C1 - 11	56
S11482001	C1 - 27	56
S11485001	E1 - 49	68
S11486009	D1 - 23	62
S11487001	D1 - 24	62
S11488001	D1 - 25	62
S11535009	B1 - 1	54
S11537000	B1 - 1-2-1	54
S11540000	B1 - 3	54
S11541000	D1 - 1	62
S11543000	D1 - 3	62
S11544000	D1 - 4	62
S11545000	D1 - 5	62
S11546000	D1 - 21	62
S11548000	D1 - 19	62
S11550000	B1 - 2-1	54
S11551000	D1 - 66	64
S11552009	D1 - 22	62
S11553000	D1 - 22-1	62

CODE	REF.NO.	PAGE
S11554001	D1- 22-2	62
S11555000	D1- 22-3	62
S11556001	D1- 22-4	62
S11557001	D1- 64	64
S11558000	D1- 65	64
S11680000	F1- 65	76
S11681000	F1- 66	76
S11682000	F1- 67	76
S12150000	C1- 22	56
S12225000	F1- 3	74
S12609001	Z - 119	80
S13020001	J - 5-13	20
S13086001	F1- 50	74
S13594080	B - 10	6
	Z - 11	78
S13594090	B - 10	6
	Z - 11	78
S13597001	Z - 120	80
S13633001	K - 8	24
S13634001	K - 5	24
S13635001	K - 7	24
S13649001	J - 54	22
S13650001	J - 55	22
S13651001	J - 33	20
S13652009	J - 24	20
S13713001	S - 56	40
S13727001	E - 21	14
S14037000	D1- 70-1-2	66
S14045000	D1- 70-2-1	66
S14072001	Z - 26	78
S14084001	C1- 57	60
S14085001	C1- 65-1	60
S14085002	C1- 65-2	60
S14085003	C1- 65-3	60
S14085004	C1- 65-4	60
S14085005	C1- 65-5	60
S14085006	C1- 65-6	60
S14085007	C1- 65-7	60
S14085008	C1- 65-8	60
S14085009	C1- 65-9	60
S14085010	C1- 65-10	60
S14085011	C1- 65-11	60
S14150001	C1- 66	60
S14183000	E1- 145	70
S14184001	E1- 146	70
S14191009	A1- 38	50
S14192009	A1- 72	52
S14203001	E1- 37	68
S14204001	E1- 37	68
S14205000	E1- 33	68
S14328000	C1- 57-2	60
S14417009	D1- 71	66
S14418009	D1- 72	66
S14419001	D1- 70-2-2	66
S14453009	D1- 70-1	66
S15361001	D1- 70-1-1	66
S15520009	E1- 148-1	72
S15521001	E1- 148-2	72
S15855009	A - 7	2
S17062000	A - 5	2
	R - 80	36
S18013001	D1- 20	62
S18658001	B1- 1-2-3	54
S18707027	Z - 29	78
S18707028	Z - 29	78
S18707029	Z - 29	78
S18707030	Z - 29	78

CODE	REF.NO.	PAGE
S19801001	M - 63	28
S19804001	F - 1-2	16
S19805001	F - 1-3	16
S19806001	F - 1-1	16
S19807001	F - 1-8	16
S19808001	F - 3	16
S19809001	W - 36-2	48
S19810009	W - 2	48
S19811001	W - 19	48
S19812001	W - 47	48
S19813001	W - 31	48
S19814001	L - 1	24
S19815001	L - 8	24
S19817001	V - 13	44
S19818001	V - 62	46
S19820001	V - 35-1	44
	Z - 21-1	78
S19821001	V - 31	44
S19822001	V - 35-2	44
	Z - 21-2	78
S19823001	V - 35-3	44
	Z - 21-3	78
S19824001	V - 35	44
	Z - 21	78
S19825001	V - 40-1	44
S19826001	J - 38	20
S19827001	V - 57	44
S19828001	H - 7	18
S19829001	V - 1	44
S19830001	H - 12	18
S19831001	H - 27	18
S19833001	V - 27	44
S19834001	V - 29	44
S19835001	V - 8	44
S19836001	N - 16	30
S19837001	N - 24	30
S19838001	N - 21	30
S19839000	N - 23	30
S19840001	N - 27	30
S19841001	N - 4	30
S19844001	V - 40	44
S19846001	F - 1	16
S19847001	N - 7	30
S19861001	W - 46	48
S19869002	S - 15	38
S19869003	S - 6	38
S19893001	N - 11-1-1	30
S19894001	N - 11-1-4	30
	N - 11-2-4	30
S19895001	N - 1	30
S19897001	N - 11-2-1	30
S19898001	N - 11-1	30
S19899001	N - 11-2	30
S19920009	A - 4	2
S19956001	V - 40-6	44
S19961001	S - 22	38
S19963101	R - 19	34
S19965001	R - 48	34
S20014001	N - 11-1-5	30
	N - 11-2-5	30
S20017101	W - 36-1	48
S20113001	V - 60	46
002300803	B1- 1-2-7	54
002303003	C1- 12	56
002401403	B1- 1-2-4	54
004400802	D1- 63	64
008400604	A1- 37	50

CODE	REF.NO.	PAGE
008400604	B1 - 2-6	54
	D1 - 34	62
	E1 - 5	68
	F1 - 42	74
	F1 - 44	74
014060622	A1 - 53	50
014060632	E1 - 14	68
	E1 - 16	68
	E1 - 20	68
	E1 - 28	68
	E1 - 85	70
	E1 - 88	70
014400422	D1 - 10	62
014400522	A1 - 22	50
	A1 - 24	50
	A1 - 29	50
	V - 53	44
014500522	A1 - 17	50
	E1 - 66	70
014679320	C - 19	8
014680622	D - 17-11	10
	D - 17-14	10
	D - 17-7	10
	E1 - 41	68
	E1 - 43	68
	E1 - 56	68
	E1 - 77	70
	E1 - 81	70
	E1 - 92	70
	L - 9	24
	M - 11-2	26
	M - 9	26
	S - 21	38
	T - 1-11	42
	T - 6	42
014710522	E1 - 79	70
014760622	A - 13	2
	A1 - 2	50
	A1 - 77	52
	B - 14	6
	B - 16	6
	B - 7	6
	C - 30	8
	C - 6	8
	D - 12	10
	D - 30	10
	D - 6	10
	D - 8	10
	E - 11	14
	E - 17	14
	E - 30	14
	E1 - 12	68
	F - 1-6	16
	F - 10	16
	G - 1-8	16
	H - 11	18
	H - 24	18
	H - 3	18
	H - 6	18
	J - 15	20
	J - 26	20
	J - 51	22
	J - 52	22
	M - 14	26
	M - 19	26
	M - 7	26
	N - 6	30

CODE	REF.NO.	PAGE	
014760622	N - 8	30	
	P - 12	32	
	P - 6	32	
	P - 8	32	
	R - 3	34	
	R - 9	34	
	U - 1-4	42	
	U - 1-9	42	
	W - 10	48	
	W - 21	48	
	014770622	B - 3	6
		B - 6	6
		C - 28	8
		D - 1-2	10
		D - 13-2	10
D - 16		10	
D - 17-5		10	
D - 35		10	
D - 51		12	
H - 22		18	
J - 37		20	
K - 1-2		24	
K - 12		24	
K - 14		24	
K - 16-2		24	
K - 6	24		
M - 2	26		
M - 37	26		
M - 50	26		
M - 62	28		
N - 9-2	30		
P - 13-2	32		
P - 16	32		
R - 11-1-1	34		
R - 11-2-1	34		
V - 7	44		
W - 8	48		
A1 - 4	50		
017061006	F1 - 35	74	
017063002	Z - 96	80	
017066002	D1 - 73	66	
017081606	D1 - 76	66	
017501003	J - 29	20	
017711412	F - 1-9	16	
017761212	W - 14	48	
017762012	W - 3	48	
017762202	E - 3	14	
017771412	M - 70	28	
018060822	C1 - 3	56	
018061222	F - 16	16	
018061422	D1 - 61	64	
	E - 22	14	
	A - 17	2	
018061622	B1 - 4	54	
	E1 - 137	72	
	F1 - 27	74	
	V - 2	44	
	H - 31	18	
018062022	F - 1-7	16	
018062222	F1 - 30	74	
018081222	A1 - 46	50	
	F1 - 51	74	
018081422	R - 5	34	
018081622	A1 - 40	50	
	B1 - 7	54	
	E1 - 116	72	
	H - 15	18	

CODE	REF.NO.	PAGE
018082022	A1 - 60	50
	A1 - 9	50
	E - 9	14
	F1 - 18	74
	F1 - 7	74
	G - 2	16
	U - 2	42
	018082522	A1 - 71
	A1 - 73	52
	F1 - 19	74
018101622	R - 4-3	34
018400532	D1 - 35	62
	E1 - 133	72
018400632	E1 - 102	72
	E1 - 98	70
018400822	C1 - 18	56
018401022	V - 54	44
018401222	E1 - 140	72
018401622	E1 - 24	68
018402032	D1 - 27	62
018501022	E1 - 30	68
	E1 - 60	68
018501422	A1 - 86	52
	E1 - 34	68
	E1 - 73	70
018501622	E1 - 3	68
	E1 - 59	68
018502022	E1 - 7	68
018503022	C1 - 7	56
018680522	M - 76	28
018680822	M - 42	26
021060102	C1 - 31	56
	Z - 103	80
	Z - 92	78
021080302	A1 - 95	52
021200203	F1 - 4	74
021300103	D1 - 14	62
	D1 - 32	62
	D1 - 54	62
021400103	B1 - 1-2-6	54
021400202	A1 - 83	52
	D1 - 28	62
021500103	C1 - 28	56
	C1 - 42	56
021500106	C1 - 52-3	58
	Z - 41-4-3	78
	Z - 41-7-3	78
021660102	Z - 124-5	80
021670202	L - 12	24
021680202	A - 69	2
	V - 15	44
021710202	E - 7-9	14
021860312	E - 7-13	14
021910302	J - 4	20
	M - 34	26
022120306	A1 - 43-1	50
025030232	Z - 124-4	80
025030233	B1 - 1-2-8	54
	B1 - 2-4	54
	D1 - 31	62
	D1 - 50	62
	D1 - 53	62
	D1 - 58	64
	F1 - 15	74
025040232	A1 - 84	52
	C1 - 56	58
	E1 - 100	70

CODE	REF.NO.	PAGE
025040232	E1 - 134	72
	025040233	A1 - 81
	D1 - 38	62
	E1 - 125	72
025050232	E1 - 32	68
025050233	D1 - 78	66
025060132	H - 21-3	18
025060232	A - 18	2
	A1 - 57	50
	A1 - 68	52
	B1 - 5	54
	C1 - 34	56
	E1 - 139	72
	F - 1-10	16
	F - 17	16
	F1 - 32	74
	F1 - 37	74
	L - 2	24
025060332	G - 1-6	16
	Z - 104	80
025080132	E - 28	14
	F - 1-4	16
	T - 1-5	42
025080232	A1 - 11	50
	A1 - 42	50
	A1 - 48	50
	A1 - 62	50
	A1 - 94	52
	E1 - 118	72
	E1 - 148-4	72
	F1 - 21	74
	F1 - 9	74
	G - 3	16
	H - 13	18
	H - 8	18
	R - 6	34
	W - 12	48
025080236	D1 - 75	66
025100132	E - 25	14
	E - 7-16	14
	E - 7-19	14
	E - 7-3	14
	J - 34	20
	R - 4-4	34
	Z - 100	80
025100232	A1 - 98	52
025350332	L - 13	24
	L - 3	24
025680132	F - 19	16
	M - 60	26
	M - 66	28
	S - 33	38
	S - 53	40
	V - 16	44
025680232	A - 84	4
	E1 - 131	72
	J - 44	20
	J - 58	22
	V - 23	44
	V - 26	44
	V - 55	44
	V - 59	44
025710232	J - 28	20
025770232	E - 36	14
025900232	C - 33	8
	J - 3	20
028030242	C1 - 13	56

CODE	REF.NO.	PAGE
028030242	C1 - 59	60
	E1 - 48	68
028030243	B1 - 1-2-9	54
	B1 - 2-5	54
	D1 - 13	62
	D1 - 30	62
	D1 - 49	62
	D1 - 52	62
	F1 - 16	74
028040242	C1 - 19	56
	E1 - 103	72
	E1 - 141	72
	E1 - 99	70
028040243	A1 - 30	50
	A1 - 80	52
	B1 - 1-2-5	54
028050240	E - 7-8	14
028050242	C1 - 8	56
	E1 - 147	70
	E1 - 31	68
	E1 - 35	68
	E1 - 61	68
	E1 - 74	70
	E1 - 8	68
	J - 41	20
028050243	C1 - 29	56
	C1 - 41	56
	D1 - 77	66
028050246	Z - 41-7-2	78
028060242	A1 - 56	50
	A1 - 67	52
	B1 - 6	54
	C1 - 4	56
	E1 - 138	72
	F1 - 28	74
	F1 - 31	74
	F1 - 36	74
	Z - 105	80
028080242	A1 - 10	50
	A1 - 41	50
	A1 - 47	50
	A1 - 61	50
	A1 - 74	52
	A1 - 93	52
	B1 - 8	54
	E1 - 117	72
	F1 - 20	74
	F1 - 8	74
	H - 14	18
028080246	D1 - 74	66
028100242	A1 - 97	52
028680242	J - 59	22
	V - 56	44
032311306	C1 - 64	60
032422006	C1 - 61	60
032452502	A1 - 51	50
034311302	F1 - 33	74
034362006	F1 - 10-2	74
047301842	K - 4	24
048025342	E1 - 94	70
048030342	W - 18	48
048040342	H - 21-4	18
	S - 42	38
048050342	C1 - 33	56
	D - 20	10
	T - 1-15	42
048060342	A1 - 15	50

CODE	REF.NO.	PAGE
048060342	E - 29	14
	E1 - 27	68
	F - 1-5	16
	H - 9	18
	T - 1-6	42
	W - 11	48
048070342	A - 97	4
048080342	J - 35	20
	W - 23	48
	Z - 99	80
048100142	E - 26	14
	E - 7-17	14
	E - 7-4	14
	G - 1-10	16
048110142	J - 17	20
048120142	E1 - 22	68
	V - 5	44
048150142	C - 15	8
	C - 31-4	8
	P - 9	32
048170142	U - 1-11	42
048190242	A1 - 27	50
	E1 - 83	70
	E1 - 90	70
	C - 13	8
048250142	A1 - 13	50
048320242	C - 31-3	8
048350242	Z - 41-7-5	78
050501406	Z - 41-7-4	78
050503006	B1 - 1-1	54
052400806	B1 - 1-2-2	54
	B1 - 2-2	54
	B1 - 2-3	54
062300505	D1 - 12	62
062300605	D1 - 48	62
	E1 - 47	68
	F1 - 14	74
062300616	D1 - 29	62
062301606	D1 - 51	62
	C1 - 58	60
062303012	A1 - 31	50
062401006	C1 - 55	58
	A1 - 79	52
062401605	D1 - 37	62
062402512	C1 - 52-2	58
062501406	Z - 41-4-2	78
	D1 - 45	62
062660512	D1 - 41	62
062670512	R - 65	36
	S - 30	38
	W - 32	48
062670612	A - 36	2
	L - 4	24
	R - 21	34
	R - 73	36
	T - 1-13	42
062680512	D - 25	10
	D1 - 36	62
	S - 32	38
	A - 49	2
062680612	E1 - 144-8	72
	K - 24	24
	M - 59	26
	M - 65	28
	N - 15	30
	N - 22	30
	R - 63	36

CODE	REF.NO.	PAGE
062680612	S - 36	38
	S - 51	38
	V - 22	44
062680712	Q - 13	32
062680812	A - 21	2
	A - 63	2
	A - 66	2
	A - 68	2
	H - 26	18
	M - 75	28
	R - 28	34
	R - 31	34
	R - 38	34
	S - 46	38
	T - 1-4	42
	V - 58	44
062681012	A - 83	2
	J - 5-11	20
	J - 5-6	20
	J - 5-8	20
	R - 68	36
	V - 45	44
062681212	A - 91	4
	H - 20	18
	J - 5-15	20
	J - 5-2	20
	J - 5-4	20
062681412	R - 46	34
	V - 20	44
062681612	D - 37	10
062710612	F - 12	16
062710812	A - 39	2
	A - 89	4
	E1 - 109	72
	M - 54	26
	T - 2	42
062711012	A - 111	4
	N - 14	30
062711212	R - 18	34
062711412	A - 24	2
	A - 28	2
	A - 31	2
	A - 44	2
	E1 - 108	72
	J - 40	20
062760812	E - 32	14
	V - 47	44
062761012	V - 30	44
062761212	E - 14	14
	G - 1-5	16
	M - 22	26
	M - 40	26
	S - 40	38
062761612	E1 - 82	70
070626800	A1 - 25	50
070698800	E1 - 25	68
	E1 - 89	70
072062680	A1 - 26	50
072600040	R - 4-2	34
072600360	U - 1-10	42
	U - 1-6	42
072600560	C - 12	8
072620160	G - 1-4	16
072620180	A1 - 12	50
072620200	P - 10	32
072620260	C - 31-2	8
072630260	C - 7	8

CODE	REF.NO.	PAGE
076201850	E1 - 17	68
081003670	A - 34	2
081006670	M - 16	26
	V - 51	44
081007070	M - 6	26
081010670	E - 37	14
081011070	M - 15	26
	M - 53	26
081011670	H - 40	18
081048070	C - 5	8
100022005	D - 53	12
100075004	E - 7-14	14
100136001	T - 9	42
100250001	B - 2	6
100279109	H - 33	18
100402004	S - 18-8	38
100887001	Z - 4	78
101118001	Z - 115	80
101125000	F1 - 23	74
	Z - 116	80
101486001	D - 11	10
101572101	Z - 3	78
102843004	C - 10	8
	U - 1-14	42
103950003	S - 19	38
104449009	A - 50	2
104450109	A - 51	2
	P - 2	32
	U - 3	42
104908004	L - 7	24
105073001	Z - 27	78
105173004	E1 - 105	72
	E1 - 120	72
	E1 - 54	68
	E1 - 63	68
105234003	A - 93	4
105451002	L - 11	24
105812003	D - 27	10
106568003	J - 46	20
106588003	K - 18-3	24
	V - 33	44
	W - 4	48
107017002	A - 42	2
	A - 47	2
107153001	R - 71	36
107200001	M - 74	28
	Z - 18	78
107231002	K - 22	24
107321003	A - 41	2
	A - 46	2
107401001	J - 48-1-3	22
	J - 48-2-3	22
107404001	J - 48-1-4	22
	J - 48-2-4	22
107407003	F - 18	16
	M - 56	26
107419002	E1 - 130	72
107550002	J - 13	20
107744001	W - 15	48
107780001	Z - 6	78
109203001	R - 26	34
110161004	W - 17	48
110215002	W - 34	48
110367001	B - 4	6
	R - 12	34
110494001	W - 22	48
110495003	J - 36	20

CODE	REF.NO.	PAGE
110495003	K - 11	24
110558001	D - 31	10
110641002	R - 25	34
110820101	S - 1	38
111237001	B - 5-3	6
111468001	B - 5-6	6
111865001	C - 35	8
112144001	D1- 26	62
112348001	R - 69	36
112364001	R - 50	36
112467002	R - 17-8	34
112700001	K - 18-2	24
112751002	S - 23	38
	S - 25	38
	S - 48	38
113316001	S - 24	38
113590001	A - 3	2
114255002	P - 3	32
114294001	S - 18-2	38
115007001	D - 32	10
	V - 4	44
115120001	M - 79	28
115157001	Z - 5	78
115166001	E1- 127	72
115188001	T - 8	42
115503001	M - 45	26
	V - 36	44
115544001	E - 7-6	14
115545001	E - 7-5	14
115546001	E - 7-7	14
115550001	E - 7-20	14
115551001	E - 7-18	14
115558002	E - 13	14
115559002	E - 35	14
115585001	E - 19	14
115947001	A1- 5	50
	Z - 91	78
116735000	B - 5-7	6
116795000	E - 38	14
116920001	C - 14	8
	P - 17	32
117006001	E - 39	14
117348001	C - 26	8
117466000	Z - 13	78
117671002	D - 34	10
	V - 6	44
117934009	A - 52	2
	N - 25	30
118764002	T - 14	42
118837001	Z - 2	78
120448001	T - 1-10	42
	Z - 117	80
122991001	Z - 94	80
126863001	Z - 41-10	78
130502001	Z - 126	80
140004001	B - 5-4	6
140430001	B - 5-8	6
140553102	B - 11	6
140647001	C1- 62	60
	D1- 43	62
140682001	C1- 6-4	56
140947002	A1- 82	52
141248001	A - 92	4
141276001	U - 1-13	42
141309001	D - 1-1	10
141334001	D - 40	10
	E - 34	14

CODE	REF.NO.	PAGE
141334001	H - 34	18
141351001	D - 50	12
	W - 7	48
141367001	K - 1-1	24
141377000	Z - 20-1	78
141378000	K - 15-1	24
141379000	Z - 20-2	78
141381000	Z - 20-3	78
141382000	K - 15-2	24
141383000	Z - 20-4	78
141400001	J - 6	20
	Z - 102	80
141408001	J - 7	20
141439001	J - 47	20
141492001	V - 34	44
141494001	V - 48	44
141514001	V - 35-4	44
	Z - 21-4	78
141519001	W - 16	48
141590001	S - 54	40
141642000	R - 17-2	34
141643000	R - 17-1	34
141650000	R - 52	36
141711100	Z - 28	78
142268001	C1- 63	60
	D1- 44	62
	R - 72	36
142359001	R - 14	34
	R - 66	36
142374000	J - 31	20
142443001	Z - 1	78
142628001	J - 16	20
142667101	E - 7-2	14
142711001	A - 108	4
142721001	Z - 10	78
142748002	R - 23	34
142750001	R - 75	36
142750002	R - 22	34
142766001	R - 8	34
143713101	R - 42	34
143787001	A - 71	2
143793001	N - 26	30
143915001	R - 11-1	34
143966001	Z - 124-2	80
144086001	R - 81	36
144103009	S - 12	38
	S - 3	38
144104001	S - 4	38
144105000	S - 14	38
	S - 5	38
144505000	T - 10	42
144526001	S - 44	38
144741001	S - 18-1	38
144876001	R - 17-7	34
145247001	W - 39	48
145318001	W - 37	48
	W - 41	48
145370001	Z - 125	80
145446001	S - 10	38
	S - 18-5	38
	S - 2	38
	T - 7	42
145465001	B - 5-1	6
	R - 17-5	34
145480001	A1- 88	52
	D - 22	10
	H - 29	18

CODE	REF.NO.	PAGE
145519001	S - 18-4	38
145751001	R - 78	36
146198001	T - 13	42
146199001	T - 12	42
146200001	T - 11	42
146254001	Z - 38	78
146293001	D - 33	10
146354001	E1 - 36	68
	E1 - 9	68
146549001	E1 - 128	72
147113001	J - 48-1-1	22
148053001	B - 8-2-2	6
148469001	R - 17-3	34
148470001	R - 17-4	34
148471001	R - 17-6	34
148761001	R - 17	34
148847001	E1 - 121	72
	E1 - 95	70
149069101	D1- 55	62
149070009	D1- 56	62
149095001	H - 39	18
149342001	A1- 45	50
149486001	A1- 92	52
149487001	A1- 96	52
149488001	A1- 99	52
149547000	D1- 33	62
	D1- 39	62
	R - 70	36
149566009	S - 15-1	38
	S - 6-1	38
149796001	Z - 128	80
149799000	R - 74	36
150106003	C1- 52	58
	Z - 41-4	78
150172003	Z - 41-3	78
150173003	C1- 52-1	58
	Z - 41-4-1	78
150174000	Z - 41-5	78
150179002	Z - 41-7-1	78
150180001	Z - 41-8	78
150182000	Z - 41-9	78
150191002	Z - 41-2-2	78
150206002	Z - 41-2-1	78
150335001	Z - 9	78
150349001	C1- 44	56
	F1- 55	74
	F1- 56	74
150357001	F1- 68	74
150451001	A1- 91	52
150553001	V - 61	46
150553003	S - 55	40
150554002	M - 72	28
150556001	A1- 90	52
150756009	A - 35	2
	R - 10	34
151059001	A - 2	2
151932001	K - 21	24
152750001	J - 22	20
152765001	Z - 7	78
152937001	R - 64	36
152948001	R - 24	34
152997001	E - 20	14
153057002	J - 43	20
	J - 57	22
	M - 44	26
	V - 25	44
153138001	D - 21	10

CODE	REF.NO.	PAGE
153242000	Z - 122	80
153274001	C1- 6-5	56
153689001	E1 - 23	68
154332001	A1 - 89	52
154528001	T - 1-9	42
154578000	A - 101	4
154702001	Z - 24	78
155697002	S - 15-2	38
155697003	S - 6-2	38
156112003	Z - 41-1	78
156641001	D - 4	10
158653000	E1 - 107	72
158823001	M - 61-2	28
158824001	M - 61	28
158827009	Z - 86	78
158828009	Z - 87	78
158830001	Z - 97	80
158831001	Z - 98	80
158832009	Z - 101	80
158833001	A - 19	2
158834000	A - 20	2
158836009	A - 22	2
158837000	A - 23	2
158838009	A - 26	2
158839000	A - 27	2
158840109	A - 29	2
158841000	A - 30	2
158842001	A - 32	2
158843001	A - 33	2
158844001	A - 37	2
158845009	A - 38	2
158847001	A - 40	2
158849009	A - 43	2
158851101	A - 45	2
158852009	A - 48	2
158864001	A - 64	2
158865001	A - 65	2
158866009	A - 62-1	2
158867001	A - 62-2	2
158868001	A - 62-3	2
158869001	A - 67	2
158870009	A - 70	2
158875001	A - 72	2
158880000	B - 1	6
158882009	A - 53	2
158884201	B - 8-1	6
158885201	B - 8-1-1	6
158886101	B - 12	6
158888001	B - 13	6
158889001	B - 15	6
158891001	C - 1	8
158892001	C - 2	8
158893000	C - 3	8
	P - 7	32
158894000	C - 4	8
158895001	C - 8	8
158896001	C - 9	8
158897001	C - 11	8
158898001	C - 16	8
158899009	A - 61	2
158901101	C - 24	8
158904001	C - 25	8
158906001	C - 31	8
158907001	C - 31-1	8
158908001	C - 31-5	8
158909001	C - 32	8
158910000	C - 34	8

CODE	REF.NO.	PAGE
158911001	D - 3	10
158913001	D - 5	10
158914001	D - 7	10
158915001	D - 9	10
158916009	D - 10	10
158917001	D - 13-1	10
158919101	D - 15	10
158920001	D - 17-3	10
158921001	D - 17-4	10
158922001	D - 17-6	10
158923001	D - 17-8	10
158924001	D - 17-9	10
158925001	D - 17-10	10
158926001	D - 19	10
158927001	D - 17-13	10
158928000	D - 17-12	10
158929001	D - 28	10
158930001	D - 23	10
158931001	D - 24	10
158932000	D - 18	10
158933001	D - 29	10
158935001	D - 38	10
158939001	D - 39	10
158940001	D - 41	10
158941001	C - 20	8
158942001	D - 43	10
158944001	D - 43-1	10
158945001	D - 44	10
158946001	D - 45	12
158947001	D - 17-1	10
158948001	D - 46	12
158950000	D - 47	12
158951000	D - 48	12
158952001	D - 49	12
158953001	E - 1	14
158955001	E - 1-1	14
158956001	E - 2	14
158957001	E - 4	14
158958101	E - 6	14
158959001	E - 8	14
158960001	E - 7-1	14
158961001	E - 10	14
158962001	E - 7-10	14
158963001	E - 7-11	14
158964001	E - 7-12	14
158965001	E - 7-15	14
158968001	E - 15	14
158969001	A - 95	4
158970001	E - 16	14
158971001	E - 18	14
158973001	E - 23	14
158974101	E - 24	14
158975001	E - 27	14
158976001	E - 31	14
158979001	E - 33	14
158980001	A - 90	4
158981101	U - 1-12	42
158982101	J - 48-2	22
158984101	U - 1-3	42
158986101	U - 1-7	42
158987101	U - 1-8	42
158995001	F - 8	16
158996001	F - 9	16
158997001	F - 11	16
158998001	F - 13	16
158999100	F - 14	16
159000101	F - 15	16

CODE	REF.NO.	PAGE
159007101	G - 1-1	16
159008001	G - 1-2	16
159011000	G - 1-3	16
159012001	G - 1-7	16
159013001	G - 1-9	16
159014101	H - 1	18
159015101	H - 1-1	18
159016001	H - 1-2	18
159017001	V - 21	44
159018001	H - 4	18
159020001	H - 5	18
159022101	H - 10	18
159024001	H - 16	18
159025001	H - 17	18
159026001	H - 19	18
159027001	H - 21-1	18
159028001	H - 21-2	18
159030000	H - 23	18
159031001	H - 25	18
159032000	H - 2	18
159034000	H - 30	18
159035001	H - 32	18
159036001	J - 1	20
159039101	J - 5-1	20
159040101	J - 5-3	20
159041101	J - 5-5	20
159042101	J - 5-7	20
159043001	J - 5-9	20
159044001	J - 5-10	20
159045001	J - 5-12	20
159046001	J - 5-14	20
159047001	J - 8	20
159048001	J - 9	20
159049001	J - 10	20
159050001	A1- 32	50
	J - 11	20
159051101	J - 12	20
159054001	J - 14	20
159055001	J - 18	20
159056001	J - 19	20
159057001	J - 20	20
159058101	J - 21	20
159062001	J - 25	20
159063001	J - 27	20
159064000	J - 30	20
159065009	J - 32	20
159071101	J - 45	20
159072101	J - 48-1	22
159078001	J - 50	22
159079000	J - 49	22
159082000	K - 3	24
159086001	K - 9	24
159087000	K - 10	24
159088001	K - 13	24
159090001	K - 16-1	24
159091009	K - 18	24
159092001	K - 19	24
159093009	K - 18-1	24
159094001	K - 20	24
159095101	K - 23	24
159096001	M - 1	26
159097001	M - 3	26
159098001	M - 4	26
159099001	M - 5	26
159100001	M - 8	26
159101000	M - 10	26
159102001	M - 11	26

CODE	REF.NO.	PAGE
159104001	M - 11-1	26
159105001	M - 12	26
159106001	M - 17	26
159107001	M - 18	26
159108001	M - 20	26
159109001	M - 21	26
159110001	M - 23	26
159111001	M - 24	26
	V - 10	44
	V - 40-3	44
159112001	M - 25	26
159113001	V - 12	44
	V - 40-5	44
159114001	M - 27	26
159115001	M - 28	26
159116001	M - 30	26
159117001	M - 31	26
159119101	M - 33	26
159120001	M - 35	26
159121001	M - 39	26
159122001	M - 41	26
159123001	M - 43	26
159124001	M - 46	26
159126001	M - 47	26
159127001	M - 48	26
159128001	M - 49	26
159129001	M - 51	26
159130001	M - 52	26
159131101	M - 55	26
159132001	M - 57	26
159133001	M - 61-1	28
159136001	M - 64	28
159137001	M - 67	28
159140001	M - 68	28
159141001	M - 69	28
159142101	M - 71	28
159143000	M - 73	28
159145001	L - 5	24
159146101	L - 6	24
159148001	L - 10	24
159150009	A - 25	2
	N - 3	30
159154001	N - 9-1	30
159158001	N - 18	30
	Z - 12	78
159159001	N - 12	30
159160000	N - 13	30
159162001	P - 1	32
159163009	P - 4	32
159164001	P - 5	32
159166001	P - 13-1	32
159169001	P - 15	32
159170000	R - 1	34
159171000	R - 2	34
159172001	R - 4	34
159173001	R - 4-1	34
159174001	R - 7	34
159175000	R - 15	34
159181001	R - 20	34
159182101	R - 27	34
159187000	R - 29	34
159188001	R - 30	34
159189000	R - 32	34
159190001	R - 33	34
159191000	R - 34	34
159192000	R - 35	34
159193000	R - 36	34

CODE	REF.NO.	PAGE
159194000	R - 39	34
159195000	R - 40	34
159199001	R - 41	34
159201009	R - 43	34
159203100	R - 45	34
159204001	R - 47	34
159207101	R - 49	36
159209000	R - 51	36
159213001	R - 61	36
159214000	R - 62	36
159218001	S - 7	38
159219101	S - 8	38
159220101	S - 9	38
159221001	S - 13	38
159222001	S - 18-3	38
159223001	S - 18-6	38
159224001	S - 20	38
159226001	S - 50	38
159228001	S - 28	38
159234001	S - 29	38
159235101	S - 31	38
159236001	S - 34	38
159237001	S - 35	38
159239001	S - 39	38
159240001	S - 41	38
159241001	S - 43	38
159242001	S - 45	38
159243001	S - 47	38
159252001	T - 1-8	42
159253001	T - 1-12	42
159256001	T - 4	42
159257001	T - 5	42
159259201	W - 1	48
159262000	V - 28	44
159263001	W - 6	48
159264001	W - 9	48
159265001	W - 13	48
159267001	W - 20	48
159268001	W - 24	48
159269001	W - 25	48
159270001	W - 26	48
159271001	W - 27	48
159272001	W - 28	48
159274001	W - 30	48
	Z - 23	78
159276201	W - 33	48
	Z - 22	78
159281001	W - 40	48
159329001	M - 36	26
159331001	S - 18-7	38
159336001	V - 3	44
159341001	V - 9	44
159343001	V - 14	44
159344001	V - 17	44
159345001	V - 18	44
159346101	V - 19	44
159348101	V - 24	44
159356001	V - 32	44
159378001	V - 38	44
159379001	V - 39	44
159381001	V - 40-2	44
159384009	Z - 35	78
159386001	Z - 26	78
159387001	Z - 26	78
159394001	H - 28	18
159395001	M - 29	26
159409101	B - 5	6

CODE	REF.NO.	PAGE
159420001	C - 22	8
159424001	C - 18	8
159425001	C - 21	8
159426001	D - 36	10
159427001	C - 17	8
159436001	E1 - 136	72
159454009	Z - 95	80
159455109	A - 6	2
159458009	Z - 89	78
159491001	M - 13	26
159546101	S - 26	38
159547001	D - 17	10
159548101	E - 7	14
159550109	U - 1	42
159551101	G - 1	16
159552001	H - 21	18
159554001	V - 46	44
159561001	B - 18	6
159562000	D - 42	10
159563000	J - 2	20
159564000	R - 53	36
159565000	R - 55	36
159566000	R - 56	36
159567000	R - 58	36
159568000	R - 59	36
159569000	R - 60	36
159570001	M - 38	26
159572000	B - 17	6
159581001	J - 48-2-1	22
159594009	A - 62	2
159595000	A - 82	2
159601000	R - 37	34
159623001	S - 18	38
159624001	B - 12-1	6
159625001	D - 43-2	10
159633001	Z - 26	78
159634001	Z - 26	78
159715001	Z - 88	78
159744100	C - 29	8
159745100	P - 11	32
159768000	W - 5	48
159805001	S - 11	38
159812001	F1 - 34	74
159812004	F1 - 34	74
159812005	F1 - 34	74
159818001	H - 18	18
159905001	D - 26	10
159906001	D - 52	12
159908001	M - 58	26
	S - 38	38
159909000	R - 67	36
159910001	Z - 90	78
159916001	B - 8-1-2	6
159917101	S - 52	38
159923001	H - 35	18
159924001	H - 36	18
159925001	H - 37	18
159926001	J - 48-1-2	22
	J - 48-2-2	22
159927001	J - 48-1-5	22
	J - 48-2-5	22
159928009	A - 73	2
	A - 96	4
159947001	H - 38	18
159948001	V - 11	44
	V - 40-4	44
159989001	A - 98	4

CODE	REF.NO.	PAGE
180515001	R - 11-2	34
180721001	N - 11-1-3-2	30
	N - 11-2-3-2	30
183216101	B - 5-5	6
183490001	N - 11-1-2	30
	N - 11-2-2	30
183507001	N - 11-1-3-3	30
	N - 11-2-3-3	30
183508001	N - 11-1-1-1	30
183526001	N - 11-2-1-1	30
183549001	E1 - 144	72
183596001	N - 11-1-1-2	30
	N - 11-2-1-2	30
183598001	N - 11-1-1-3	30
	N - 11-2-1-3	30
183643009	D1 - 70	66
183697009	E1 - 148	72
183702001	D - 1	10
S183704001	K - 1	24
183707001	D - 13	10
183708001	K - 16	24
183709001	N - 9	30
183710001	P - 13	32
215769001	D1 - 70-1-5	66
	Z - 121	80
217169000	F1 - 64	74
407437001	C1 - 32	56
522990001	D1 - 57	62
525664000	D1 - 40	62
525907000	C1 - 54	58
554482000	D1 - 42	62
602344001	U - 1-16	42

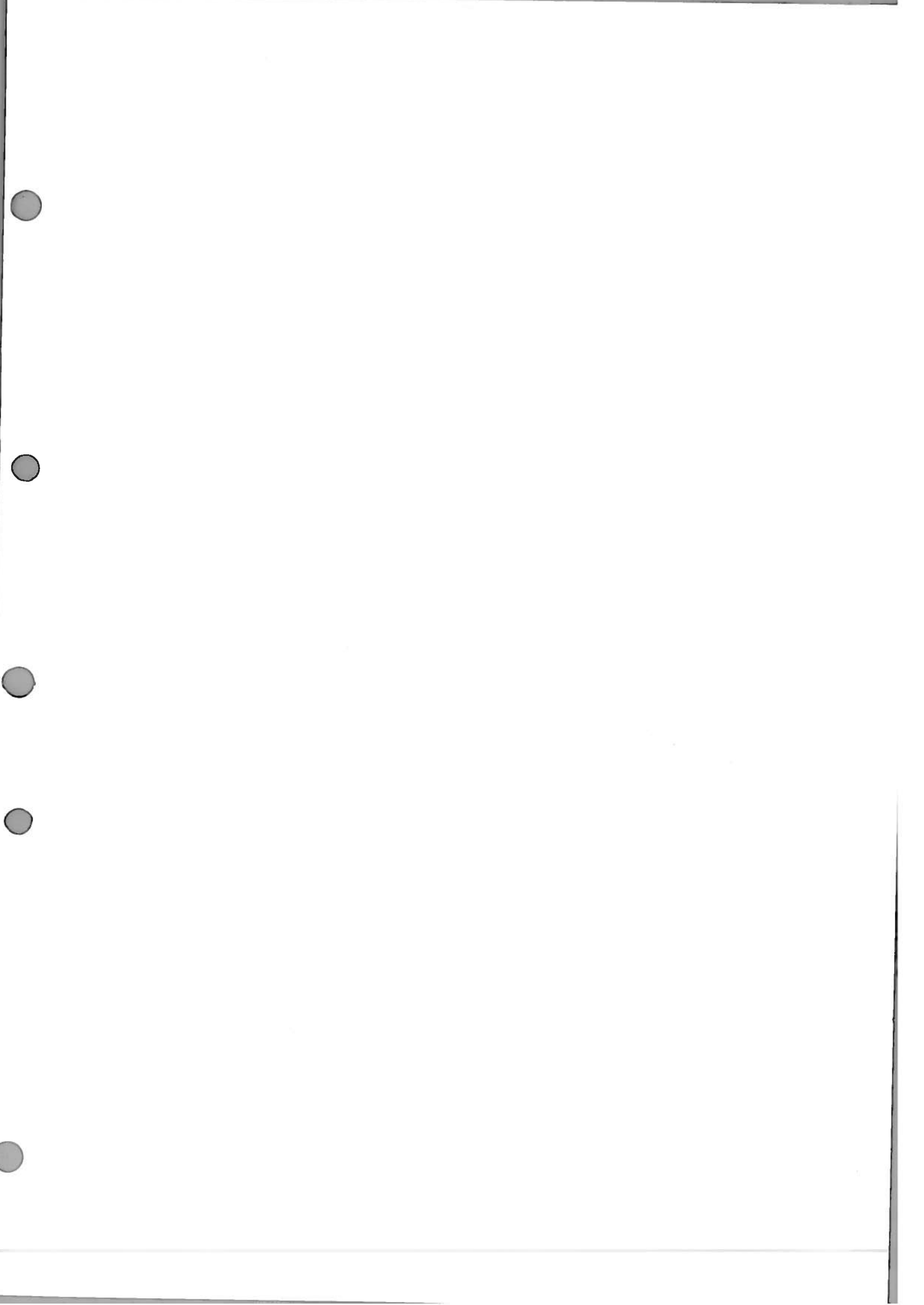

brother

ブラザー工業株式会社

〒467 名古屋市瑞穂区河岸一丁目1番1号
TEL (052) 824-2392代

BROTHER INDUSTRIES, LTD. NAGOYA, JAPAN

151-510
196510-201
1991, 03

Printed in Japan/Gedruckt in Japan/Imprimé au Japon/Impreso en Japón