

# BAS-6150

パーツブック  
PARTS BOOK

---

自動本縫玉縁機

AUTOMATIC LOCKSTITCH POCKET WELT SEWER

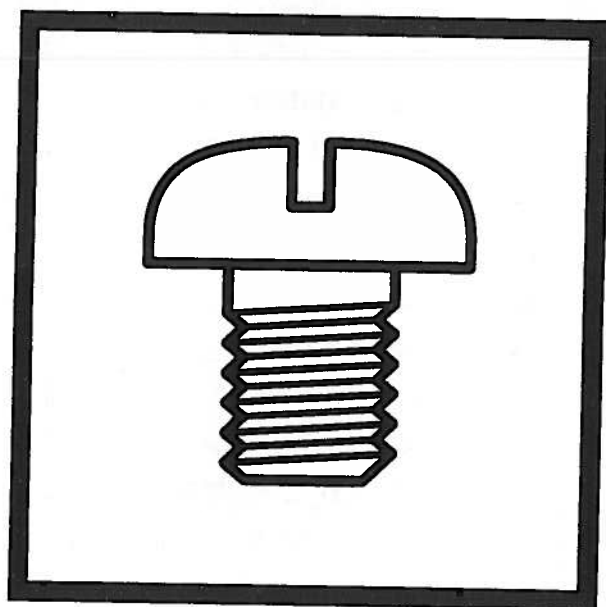

---

brother®

## パーツブックご利用に際して

- 1 この本は、2001年11月のデータに基づいて作成されたものです。
- 2 部品は予告なしに設計変更される場合があります。
- 3 組単位で補給する部品は、「 」破線で示しております。
- 4 部品コード欄が「\*」となっている場合は、ゲージ部品一覧表(75~78ページ)でお調べください。

## 目 次

|     |                             |    |      |                |    |
|-----|-----------------------------|----|------|----------------|----|
| A.  | 主体関係 .....                  | 1  | T.   | 空圧関係 .....     | 35 |
| B.  | 下軸関係 .....                  | 1  | U.   | 電装品関係 .....    | 39 |
| C.  | 上軸関係 .....                  | 3  | V1.  | 布制御関係 .....    | 43 |
| D.  | 針棒揺動関係 .....                | 5  | V2.  | 布制御関係 .....    | 47 |
| F.  | メス関係 .....                  | 7  | W.   | プリント基板関係 ..... | 51 |
| G1. | ゲージ関係 .....                 | 9  | X.   | マーカー関係 .....   | 51 |
| G2. | ゲージ関係 .....                 | 11 | Y.   | 操作パネル関係 .....  | 53 |
| H.  | カマ関係 .....                  | 13 | AA.  | 踏板関係 .....     | 53 |
| J.  | 給油潤滑関係 .....                | 15 | AB.  | 動力台関係 .....    | 55 |
| K.  | 糸通シ関係 .....                 | 19 | AC.  | コーナーメス関係 ..... | 59 |
| L1. | 糸切り関係 .....                 | 21 | AD.  | 送り装置関係 .....   | 63 |
| L2. | 糸切り関係 .....                 | 23 | AE.  | バインダー関係 .....  | 67 |
| M.  | 糸緩メ関係 .....                 | 25 | Z1.  | 付属品関係 .....    | 71 |
| N.  | モータ関係 .....                 | 25 | Z2.  | 付属品 .....      | 73 |
| P.  | 下糸検出関係 (Option Parts).....  | 27 | Ga1. | ゲージ部品一覧表 ..... | 75 |
| Q.  | 糸切れ感知関係 (Option parts)..... | 27 | Ga2. | ゲージ部品一覧表 ..... | 77 |
| R.  | スタッカー関係 (Option parts)..... | 29 | Wa.  | 警告ラベル .....    | 79 |
| S.  | 糸切り関係 .....                 | 33 |      | 索引 .....       | 80 |

## Notes for using this parts book

- 1 This book was prepared based on information available in November 2001.
- 2 Parts are subject to changes in design without prior notice.
- 3 Parts supplied as complete assemblies are circled by a dotted line .
- 4 If the symbol \* is found in the " Parts No." column, refer to the different parts lists, gauge parts list on page 75-78.

## CONTENTS

|  |    |   |    |
|--|----|---|----|
| A. Machine body.....                               | 1  | S. Bobbin winder mechanism.....         | 33 |
| B. Lower shaft mechanism.....                      | 1  | T. Air pressure mechanism.....          | 35 |
| C. Upper shaft mechanism.....                      | 3  | U. Power supply equipment mechanism.... | 39 |
| D. Needle bar rocking mechanism.....               | 5  | V1. Cloth control system mechanism..... | 43 |
| F. Knife mechanism.....                            | 7  | V2. Cloth control system mechanism..... | 47 |
| G1. Gauge parts.....                               | 9  | W. Printed circuit board mechanism..... | 51 |
| G2. Gauge parts.....                               | 11 | X. Marker mechanism.....                | 51 |
| H. Rotary hook mechanism.....                      | 13 | Y. Operation panel mechanism.....       | 53 |
| J. Lubrication.....                                | 15 | AA. Foot switch pedal mechanism.....    | 53 |
| K. Threading mechanism.....                        | 19 | AB. Power table.....                    | 55 |
| L1. Thread trimmer mechanism.....                  | 21 | AC. Corner knife mechanism.....         | 59 |
| L2. Thread trimmer mechanism.....                  | 23 | AD. Feed device mechanism.....          | 63 |
| M. Tension release mechanism.....                  | 25 | AE. Binder mechanism.....               | 67 |
| N. Motor mechanism.....                            | 25 | Z1. Accessories.....                    | 71 |
| P. Lower thread detector (Option Parts)....        | 27 | Z2. Accessories.....                    | 73 |
| Q. Thread breakage detector<br>(Option parts)..... | 27 | Ga1. Gauge parts List.....              | 75 |
| R. Stacker mechanism (Option parts).....           | 29 | Ga2. Gauge parts List.....              | 77 |
|  |    | Wa. Warning labels.....                 | 79 |
|  |    | Index .....                             | 80 |

A . 主体関係 / Machine body

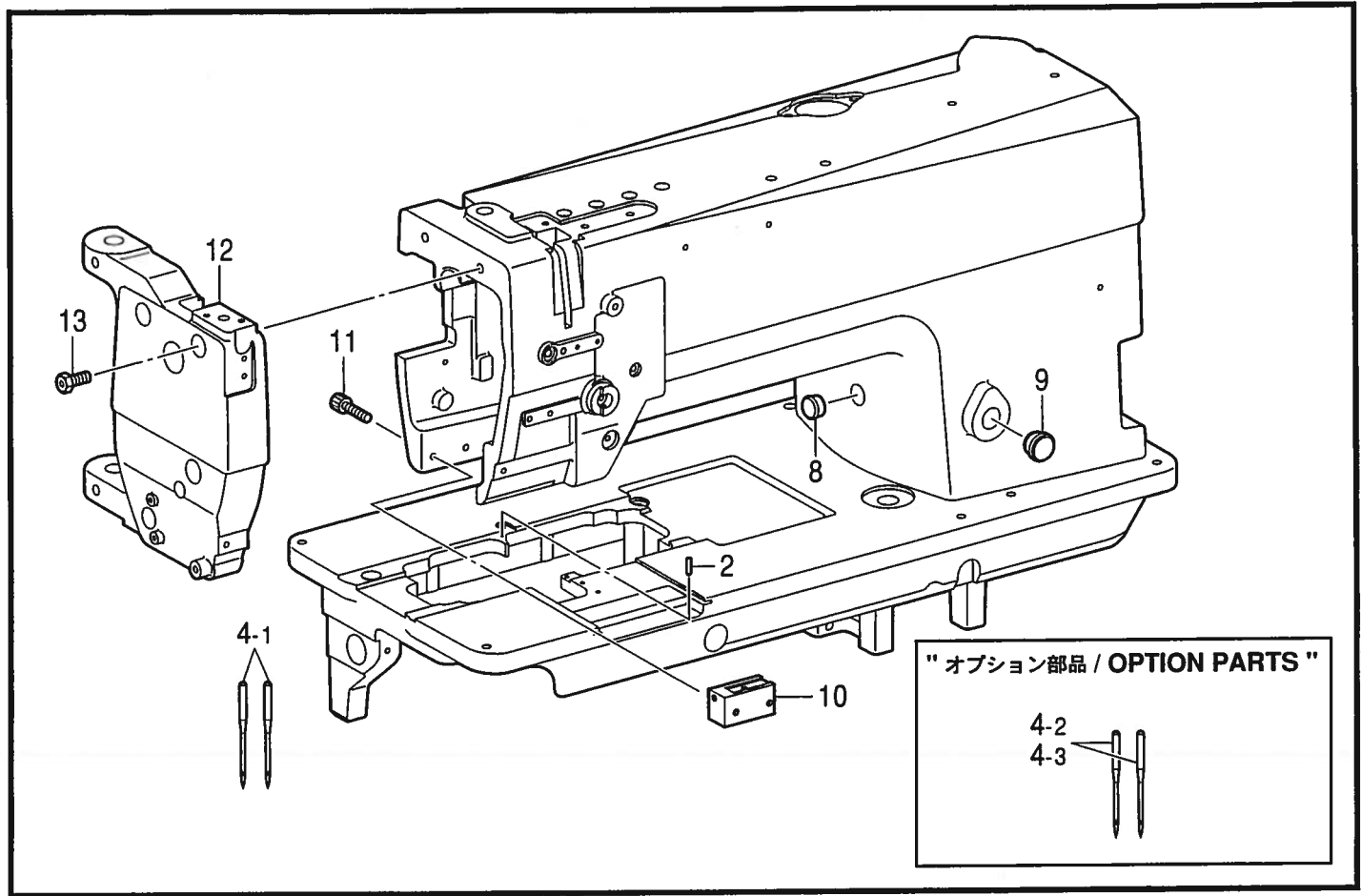

118-U73-050

B . 下軸関係 / Lower shaft mechanism

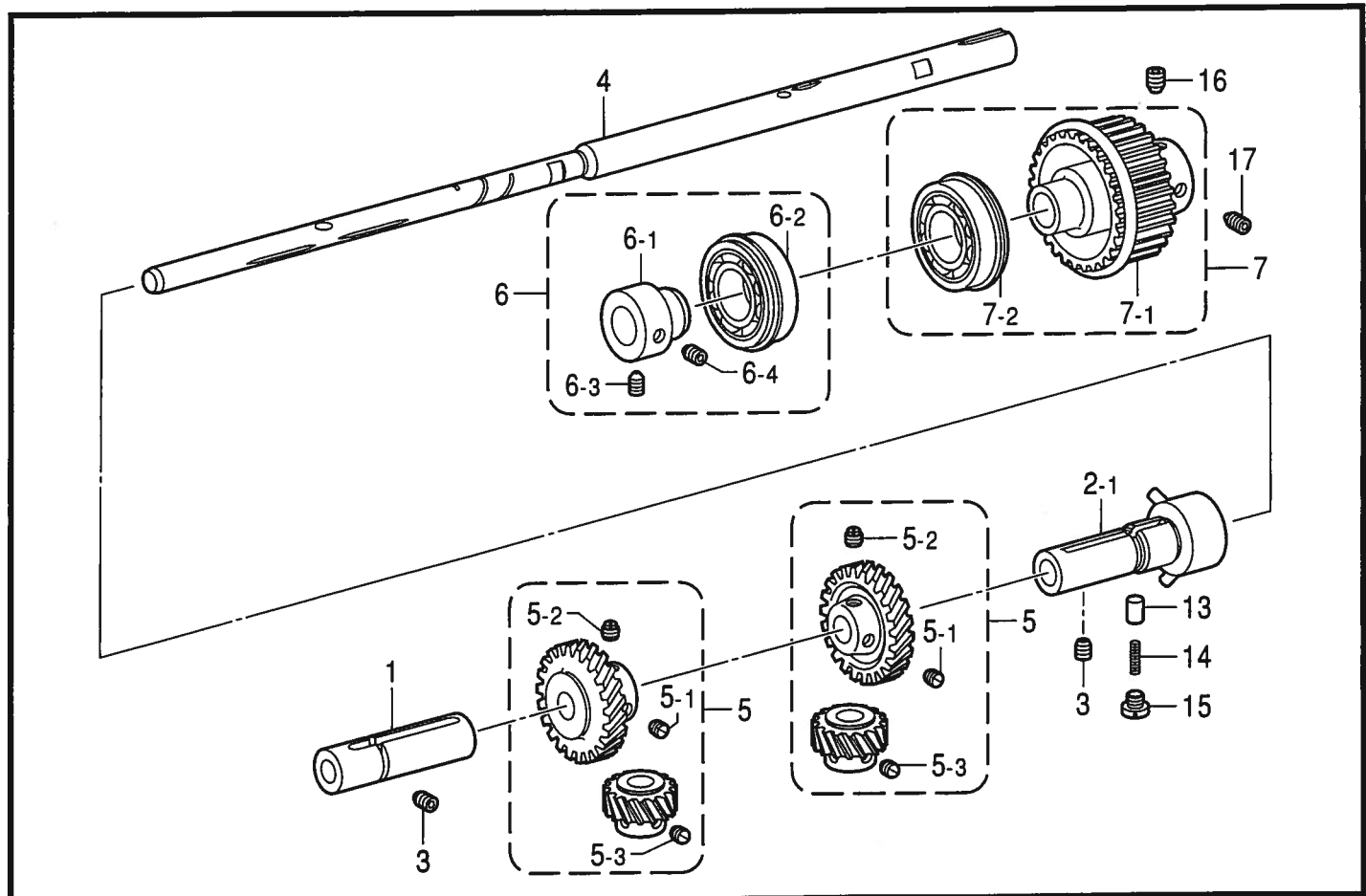

118-U73-305

## A.主体関係 / Machine body

| REF.NO | CODE      | Q'TY | ヒンメイ                      | NAME OF PARTS                | RM |
|--------|-----------|------|---------------------------|------------------------------|----|
| 2      | 113386000 | 1    | ハリタ仔キメ <sup>ン</sup>       | POSITIONING PIN              |    |
| 4-1    | 153011016 | 2    | ミシハリMTX190...<#16>        | NEEDLE, MTX190 (#16)...<#16> |    |
|        |           |      | "オプション部品"                 | "OPTION PARTS"               |    |
| 4-2    | 153011014 | 2    | ミシハリMTX190...<#14>        | NEEDLE, MTX190 (#14)...<#14> |    |
| 4-3    | 153011018 | 2    | ミシハリMTX190...<#18>        | NEEDLE, MTX190 (#18)...<#18> |    |
| 8      | 104821001 | 1    | ゴムセン10.5                  | RUBBER CAP, 10.5             |    |
| 9      | 159928000 | 1    | ゴムセン15                    | RUBBER CAP, 15               |    |
| 10     | S52523001 | 1    | イトキリジ <sup>ン</sup> ダイ     | HOLDER BLOCK                 |    |
| 11     | 018501636 | 2    | アナホル <sup>ト</sup> 5X16    | BOLT, SOCKET M5X16           |    |
| 12     | S52486101 | 1    | メンタ                       | FACE PLATE                   |    |
| 13     | S39110001 | 3    | ホル <sup>ト</sup> 595-28X14 | BOLT, W/SOCKET SM5.95-28X14  |    |

118-U73-050

## B.下軸関係 / Lower shaft mechanism

| REF.NO | CODE      | Q'TY | ヒンメイ  | NAME OF PARTS                 | RM |
|--------|-----------|------|---|-------------------------------|----|
| 1      | S38295000 | 1    | カマト <sup>ン</sup> ダイメタル  | BUSH, L ;R-HOOK BASE          |    |
| 2-1    | S48724001 | 1    | プ <sup>ン</sup> ランジ <sup>ヤ</sup> ーホ <sup>ン</sup> フ <sup>ク</sup> ミ              | PLUNGER PUMP ASSY             |    |
| 3      | 014781032 | 2    | ア <sup>ナ</sup> ホ <sup>ル</sup> ミ635-28X10                                      | SET SCREW, SOCKET (CP) SM6.35 |    |
| 4      | S38253001 | 1    | シ <sup>タ</sup> シ <sup>ク</sup>   | LOWER SHAFT, TR.              |    |
| 5      | S12445051 | 2    | ス <sup>パ</sup> イ <sup>ラ</sup> ル <sup>キ</sup> ヤ <sup>ク</sup> ミA                | SPIRAL GEAR ASSY, A           |    |
| 5-1    | 112684001 | 2    | ト <sup>メ</sup> ネ <sup>ジ</sup> 6.35  | SET SCREW, SM6.35             |    |
| 5-2    | 100251001 | 4    | ト <sup>メ</sup> ネ <sup>ジ</sup> 6.35  | SET SCREW, (CP) SM6.35-40X6.5 |    |
| 5-3    | 131007001 | 6    | ト <sup>メ</sup> ネ <sup>ジ</sup> 6.35ク <sup>ホ</sup> ミ                            | SET SCREW, (CP) SM6.35        |    |
| 6      | S07446001 | 1    | タ <sup>マ</sup> シ <sup>ク</sup> ウ <sup>ケ</sup> ク <sup>ミ</sup>                   | BALL BEARING ASSY             |    |
| 6-1    | S07447001 | 1    | タ <sup>マ</sup> シ <sup>ク</sup> ウ <sup>ケ</sup> フ <sup>ツ</sup> シ <sup>ユ</sup>    | BUSH, ;BALL BEARING           |    |
| 6-2    | 072600480 | 1    | タ <sup>マ</sup> シ <sup>ク</sup> ウ <sup>ケ</sup> 6004ZZNR                         | BALL BEARING, 6004ZZNR        |    |
| 6-3    | 148821001 | 1    | ア <sup>ナ</sup> ト <sup>メ</sup> ネ <sup>ジ</sup> 6.35ト <sup>カ</sup> リ             | SET SCREW, SOCKET (CN) SM6.35 |    |
| 6-4    | 014771022 | 1    | ア <sup>ナ</sup> ト <sup>メ</sup> ネ <sup>ジ</sup> 6.35ク <sup>ホ</sup> ミ             | SET SCREW, SOCKET (CP) SM6.35 |    |
| 7      | S38237001 | 1    | タイ <sup>ミ</sup> ン <sup>ク</sup> フ <sup>ー</sup> リ <sup>ド</sup> オ <sup>ク</sup> ミ | TIMING PULLEY SET, D          |    |
| 7-1    | S38245051 | 1    | タイ <sup>ミ</sup> ン <sup>ク</sup> フ <sup>ー</sup> リ <sup>ド</sup> ク <sup>ミ</sup>   | TIMING PULLEY ASSY, D         |    |
| 7-2    | 158115001 | 1    | タ <sup>マ</sup> シ <sup>ク</sup> ウ <sup>ケ</sup> 6204ZZNR                         | BALL BEARING, 6204ZZNR        |    |
| 13     | 144875001 | 1    | プ <sup>ン</sup> ランジ <sup>ヤ</sup> ー   | PLUNGER                       |    |
| 14     | S48732001 | 1    | プ <sup>ン</sup> ランジ <sup>ヤ</sup> ーハ <sup>ネ</sup>                               | SPRING, COMPRESSION           |    |
| 15     | 112467002 | 1    | シ <sup>メ</sup> ネ <sup>ジ</sup> 6.35  | SCREW, SM6.35X5               |    |
| 16     | 014771022 | 1    | ア <sup>ナ</sup> ト <sup>メ</sup> ネ <sup>ジ</sup> 6.35ク <sup>ホ</sup> ミ             | SET SCREW, SOCKET (CP) SM6.35 |    |
| 17     | 148821001 | 1    | ア <sup>ナ</sup> ト <sup>メ</sup> ネ <sup>ジ</sup> 6.35ト <sup>カ</sup> リ             | SET SCREW, SOCKET (CN) SM6.35 |    |

118-U73-305

C . 上軸關係 / Upper shaft mechanism

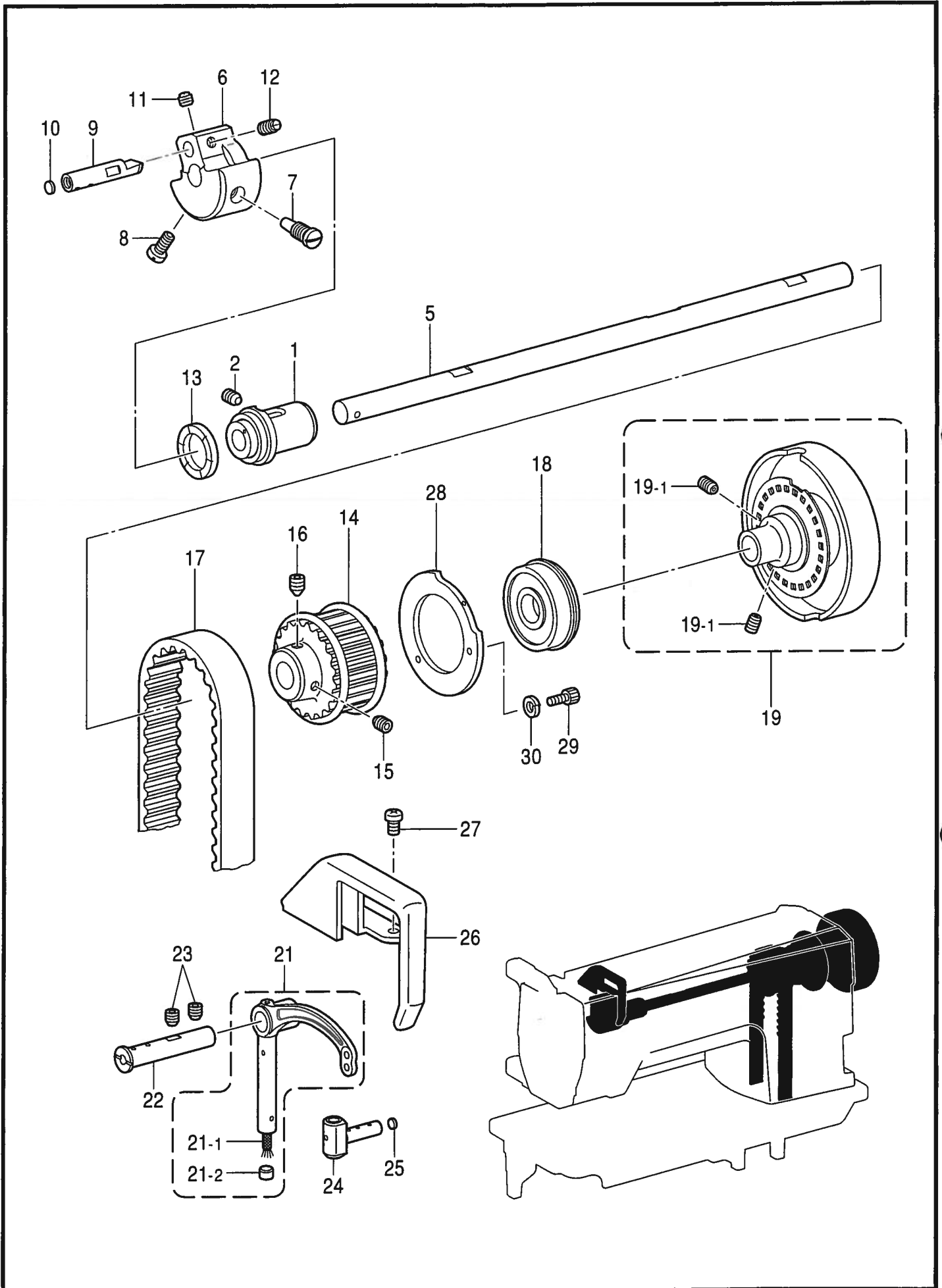

## C.上軸関係 / Upper shaft mechanism

| REF.NO | CODE      | Q'TY | ヒンメイ           | NAME OF PARTS                  | RM |
|--------|-----------|------|----------------|--------------------------------|----|
| 1      | S38270001 | 1    | ウワジクメタル        | BUSH, L ;U-SHAFT               |    |
| 2      | 014781032 | 1    | アナクホミ635-28X10 | SET SCREW, SOCKET (CP) SM6.35  |    |
| 5      | S52487001 | 1    | ウワジク           | UPPER SHAFT                    |    |
| 6      | S38396000 | 1    | テンビクランク        | THREAD TAKE-UP CRANK           |    |
| 7      | 100250001 | 1    | シメネジ7.14       | SCREW, SM7.14                  |    |
| 8      | 146141001 | 1    | アタマツキトメネジ7.14  | SET SCREW, SM7.14-28X14        |    |
| 9      | S38398001 | 1    | ハリホウクランクシク     | CRANKSHAFT, ;N-BAR             |    |
| 10     | 113014000 | 1    | クミヒモフタ         | PUSHER                         |    |
| 11     | 101706001 | 1    | トメネジ6.35       | SET SCREW, SM6.35-40X5.5       |    |
| 12     | 100251001 | 1    | トメネジ6.35       | SET SCREW, (CP) SM6.35-40X6.5  |    |
| 13     | 112576001 | 1    | テンビクランクリング     | RING, T/TAKE-UP CRANK          |    |
| 14     | S38241051 | 1    | タイミングプーリウクミ    | TIMING PULLEY ASSY, U          |    |
| 15     | 014771022 | 1    | アタメネジ6.35クホミ   | SET SCREW, SOCKET (CP) SM6.35  |    |
| 16     | 016771032 | 1    | アタカリ635X10     | SET SCREW, SOCKET (CN) SM6.35  |    |
| 17     | S38244100 | 1    | タイミングベルト       | TIMING BELT                    |    |
| 18     | 158115001 | 1    | タマシクウケ6204ZZNR | BALL BEARING, 6204ZZNR         |    |
| 19     | S57535000 | 1    | センサトククミ        | SENSOR DOG ASSY                |    |
| 19-1   | 014761030 | 2    | アナクホミ595-28X10 | SET SCREW, SOCKET(CP)SM5.95X10 |    |
| 21     | S38404001 | 1    | テンビンL2クミ       | THREAD TAKE-UP LEVER ASSY, L2  |    |
| 21-1   | S03289001 | 1    | クミヒモ4X4        | WICK, 4X4 L=40                 |    |
| 21-2   | 142274101 | 1    | ゴムセン4.2        | LUBBER CAP, 4.2                |    |
| 22     | S07334001 | 1    | テンビンシク         | SHAFT, T/TAKE-UP LEVER         |    |
| 23     | 014781032 | 2    | アナクホミ635-28X10 | SET SCREW, SOCKET (CP) SM6.35  |    |
| 24     | S07338001 | 1    | テンビンスベリコ       | SLIDE BLOCK, T/TAKE-UP LEVER   |    |
| 25     | 113024000 | 1    | クミヒモフタ         | PUSHER                         |    |
| 26     | S07339209 | 1    | テンビンカバー        | COVER, T/TAKE-UP LEVER         |    |
| 27     | 062670512 | 2    | ナハコ357-40X5    | SCREW, PAN SM3.57-40X5         |    |
| 28     | S52491001 | 1    | センサトメカラー       | STOPPER COLLAR                 |    |
| 29     | 018401036 | 2    | アナホルト4X10      | BOLT, SOCKET M4X10             |    |
| 30     | 028040246 | 2    | ハネサカネ2-4       | WASHER, SPRING 2-4             |    |

D. 針棒搖動關係 / Needle bar rocking mechanism

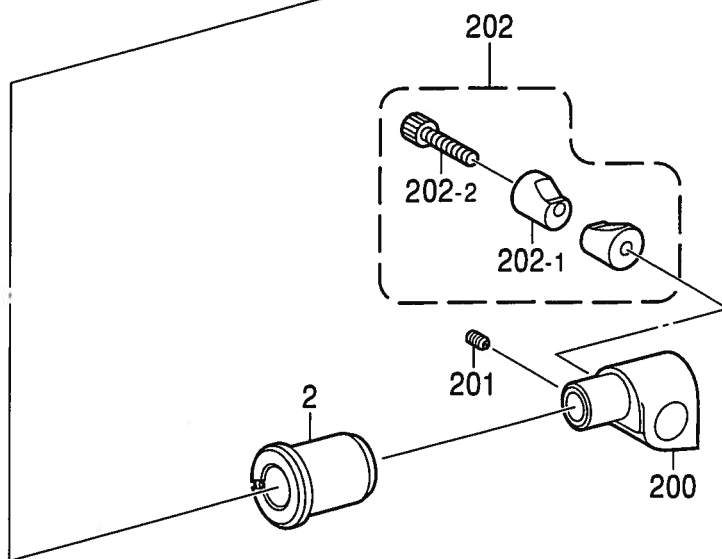
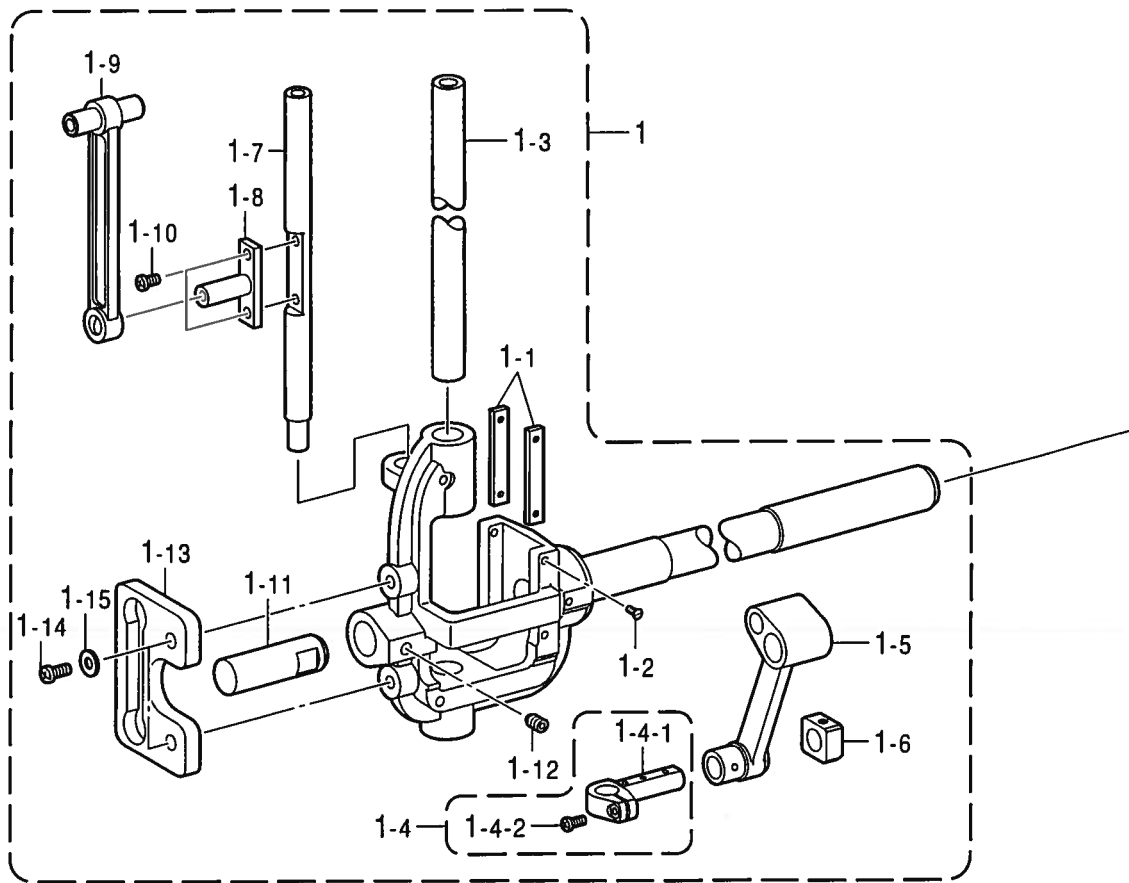



## D.針棒揺動関係 / Needle bar rocking mechanism

| REF.NO | CODE      | Q'TY | ヒンメイ            | NAME OF PARTS                 | RM |
|--------|-----------|------|-----------------|-------------------------------|----|
| 1      | S52495101 | 1    | ハリホウヨウトウシクミ     | ROCKER SHAFT ASSY, N-BAR      |    |
| 1-1    | 112590001 | 2    | ハリホウアンナイタ       | GUIDE PLATE                   |    |
| 1-2    | 102731004 | 4    | サネシ 2.38        | SCREW, FLAT SM2.38-56X4.5     |    |
| 1-3    | S59045001 | 1    | ハリホウ            | NEEDLE BAR                    |    |
| 1-4    | S29863001 | 1    | ハリホウタキネシツキ      | NEEDLE BAR CLAMP W/SCREW      |    |
| 1-4-1  | 112592001 | 1    | ハリホウタキ          | NEEDLE BAR CLAMP              |    |
| 1-4-2  | 062670812 | 1    | ナヘコ3.57-40X8    | SCREW, PAN SM3.57-40X8        |    |
| 1-5    | 112593001 | 1    | ハリホウクランクロツト     | CRANK ROD, N-BAR              |    |
| 1-6    | 112721001 | 1    | ハリホウレンカンカクコマ    | SLIDE BLOCK                   |    |
| 1-7    | S52497001 | 1    | メスホウ            | KNIFE BAR                     |    |
| 1-8    | S52498001 | 1    | メスホウアンナイ        | GUIDE, K-BAR                  |    |
| 1-9    | S52499001 | 1    | ナカメスレンカンB       | CONNECTING ROD, B             |    |
| 1-10   | 062670812 | 2    | ナヘコ3.57-40X8    | SCREW, PAN SM3.57-40X8        |    |
| 1-11   | S52500001 | 1    | ハリホウヨウトウシクL     | ROCKER SHAFT, L               |    |
| 1-12   | 014780622 | 1    | アナトメネシ 6.35クホミ  | SET SCREW, SOCKET (CP) SM6.35 |    |
| 1-13   | S52524001 | 1    | メスホウカイト         | GUIDE, K-BAR                  |    |
| 1-14   | 062681412 | 2    | ナヘコ437-40X14    | SCREW, PAN SM4.37-40X14       |    |
| 1-15   | 025680132 | 2    | ヒラサガネシヨウ4.37    | WASHER, PLAIN S 4.37          |    |
| 2      | 112594051 | 1    | ヨウトウシクメタル       | BUSH, L                       |    |
| 200    | 153012101 | 1    | ヨウトウシクストツハ      | STOPPER                       |    |
| 201    | 014781032 | 1    | アナクホミ 635-28X10 | SET SCREW, SOCKET (CP) SM6.35 |    |
| 202    | S09132051 | 1    | ピンチスリーブクミ       | PINCH SLEEVE ASSY             |    |
| 202-1  | 152725000 | 1    | ピンチスリーブ         | PINCH SLEEVE                  |    |
| 202-2  | 018063022 | 1    | アナホルト6X30       | BOLT, SOCKET M6X30            |    |

F. メス関係 / Knife mechanism

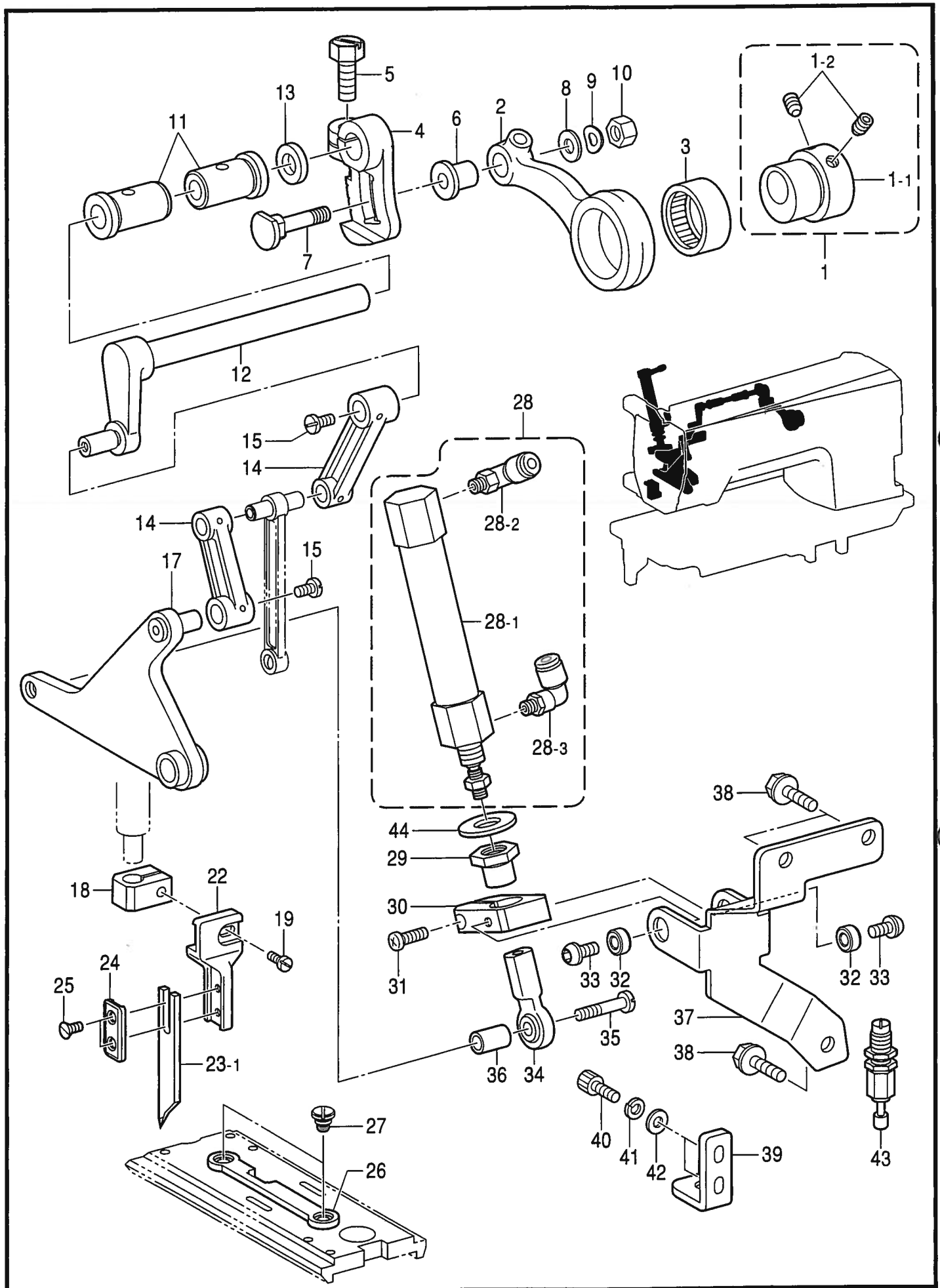

118-U73-225

## F.メス関係 / Knife mechanism

| REF.NO | CODE      | Q'TY | ヒンメイ  | NAME OF PARTS                 | RM |
|--------|-----------|------|---|-------------------------------|----|
| 1      | S52507001 | 1    | ヘンジンリンネジ <sup>ツキ</sup>                      | ECCENTRIC WHEEL W/SCREW       |    |
| 1-1    | S52508001 | 1    | ナカメスクト <sup>ウヘンジンリン</sup>                   | DRIVING ECCENTRIC WHEEL       |    |
| 1-2    | 014771022 | 2    | アナトメネジ <sup>6.35クホ<sup>ミ</sup></sup>        | SET SCREW, SOCKET (CP) SM6.35 |    |
| 2      | S48715000 | 1    | ウウオクリヘンジンリンレンカン                             | CONNECTING ROD, ;ECCENTRIC    |    |
| 3      | 118954000 | 1    | ニードル <sup>ヘ<sup>ア</sup>リング</sup>            | NEEDLE BEARING                |    |
| 4      | S48716001 | 1    | ウウオクリヘンジンリンクランク                             | ECCENTRIC CRANK               |    |
| 5      | 150936001 | 1    | シメネジ <sup>6.35</sup>                        | SCREW, SM6.35-28X14           |    |
| 6      | 150937101 | 1    | カラー   | COLLAR                        |    |
| 7      | 150938201 | 1    | ヒンジ <sup>ネジ</sup>                           | HINGE SCREW                   |    |
| 8      | 151090001 | 1    | スラストサ <sup>カ<sup>ネ</sup></sup>              | WASHER, THRUST                |    |
| 9      | 107017002 | 1    | ナミハ <sup>ネサ<sup>カ<sup>ネ</sup></sup></sup>   | WASHER, WAVE SPRING 6.45      |    |
| 10     | 110744002 | 1    | ナツト <sup>6.35</sup>                         | NUT, SM6.35                   |    |
| 11     | S48776000 | 2    | ウウオクリジ <sup>クメタル</sup>                      | BUSH, ;U-FEED SHAFT           |    |
| 12     | S52509001 | 1    | ヨウト <sup>ウウテ</sup>                          | ROCKER ARM                    |    |
| 13     | S53180001 | 1    | カラー   | COLLAR                        |    |
| 14     | S52512001 | 2    | ナカメレンカンA                                    | CONNECTING ROD, A ;I-KNIFE    |    |
| 15     | S16350001 | 2    | シメネジ <sup>4.37</sup>                        | SCREW, SM4.37                 |    |
| 17     | S52514001 | 1    | ナカメスクト <sup>ウレンカン</sup>                     | DRIVING ROD, I-KNIFE          |    |
| 18     | S59149001 | 1    | メスホルダ <sup>-U</sup>                         | KNIFE HOLDER, U               |    |
| 19     | 105216001 | 1    | シメネジ <sup>3.57</sup>                        | SCREW, SM3.57X7               |    |
| 22     | S59150001 | 1    | メスホルダ <sup>-D</sup>                         | KNIFE HOLDER, D               |    |
| 23     | S59152001 | 1    | ウウメSC                                       | UPPER KNIFE, C                |    |
| 24     | S59151001 | 1    | ナカメササエ                                      | KNIFE SUPPORT                 |    |
| 25     | 108960002 | 2    | サネジ <sup>3.57</sup>                         | SCREW, FLAT SM3.57            |    |
| 26     | S36355001 | 1    | セラミツクコ <sup>テハ</sup>                        | FIXED KNIFE, CERAMIC          |    |
| 27     | 148539101 | 2    | ダンネジ <sup>2.38</sup>                        | SHOULDER SCREW, SM2.38        |    |
| 28     | S52518000 | 1    | シリンダ <sup>クミ</sup>                          | CYLINDER ASSY                 |    |
| 28-1   | S52519000 | 1    | シリンダ <sup>16X45</sup>                       | CYLINDR,16X45                 |    |
| 28-2   | S53168000 | 1    | ツキ <sup>テ</sup> KQ2K04M5                    | JOINT, KQ2K04M5               |    |
| 28-3   | S53488000 | 1    | ツキ <sup>テ</sup>                             | JOINT                         |    |
| 29     | S53167000 | 1    | ナツト <sup>M10</sup>                          | NUT, M10                      |    |
| 30     | S52520001 | 1    | シリンダ <sup>ダイ</sup>                          | CYLINDR BRACKET               |    |
| 31     | 062681212 | 1    | ナベ <sup>コ</sup> 437-40X12                   | SCREW, PAN SM4.37-40X12       |    |
| 32     | S32843001 | 2    | カムコロ  | CAM ROLLER                    |    |
| 33     | 153057102 | 2    | オクリイタ <sup>シメネジ</sup>                       | SCREW, ROUND W/SOCKET SM4.37  |    |
| 34     | S53169001 | 1    | タマツキ <sup>テ</sup> M5クミ                      | JOINT ASSY, M5                |    |
| 35     | S06994001 | 1    | シメネジ <sup>6.35</sup>                        | SCREW, SM6.35                 |    |
| 36     | S53174001 | 1    | スベ <sup>-サ</sup>                            | SPACER                        |    |
| 37     | S52521001 | 1    | ナカメスシリンダ <sup>ササエ</sup>                     | CYLINDER SUPPORT              |    |
| 38     | S20849101 | 3    | フランジ <sup>ホルト</sup> 6X16ホソメ                 | BOLT, FLANGE M6X16            |    |
| 39     | S55896001 | 1    | ナカメスツツパ <sup>-ダイ</sup>                      | STOPPER BRACKET, INNER KNIFE  |    |
| 40     | 018401436 | 2    | アナ <sup>ホルト</sup> 4X14                      | BOLT, SOCKET M4X14            |    |
| 41     | 028040246 | 2    | ハ <sup>ネサ<sup>カ<sup>ネ</sup></sup></sup> 2-4 | WASHER, SPRING 2-4            |    |
| 42     | 025040136 | 2    | ヒラサ <sup>カ<sup>ネ</sup></sup> シヨウ4           | WASHER, PLAIN S 4             |    |
| 43     | S14874000 | 1    | シヨックアブ <sup>ソ<sup>-バ</sup></sup>            | SHOCK ABSORBER                |    |
| 44     | 025100232 | 1    | ヒラサ <sup>カ<sup>ネ</sup></sup> チユウ10          | WASHER, PLAIN M 10            |    |

< 国内用 / For Japan only > 10mm

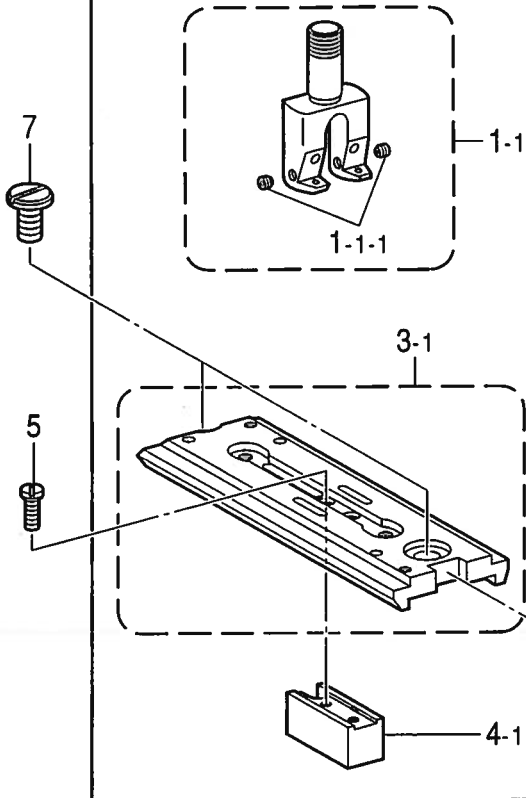

< 輸出用 / For Export > 12mm

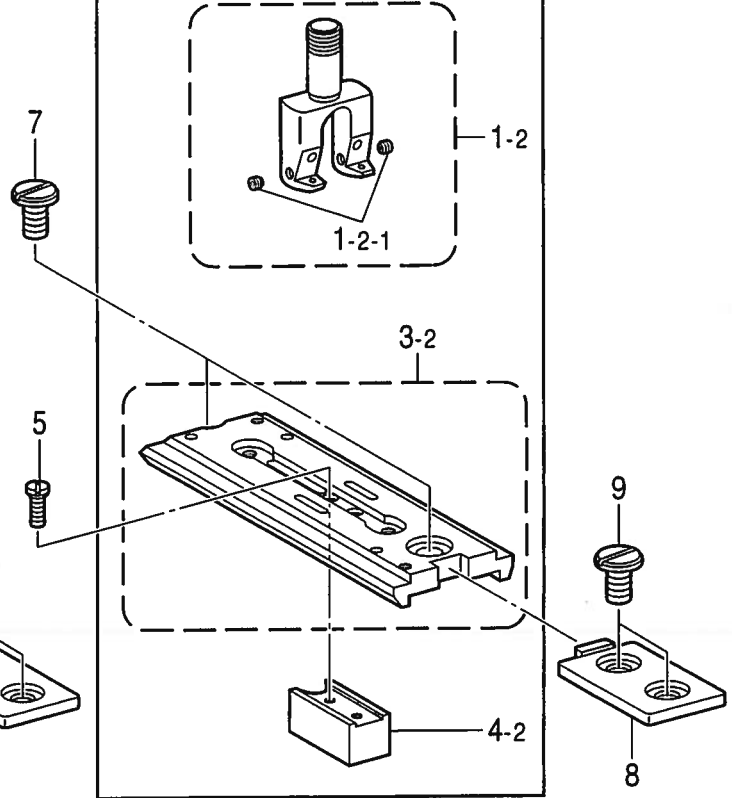

" オプション部品 / OPTION PARTS "

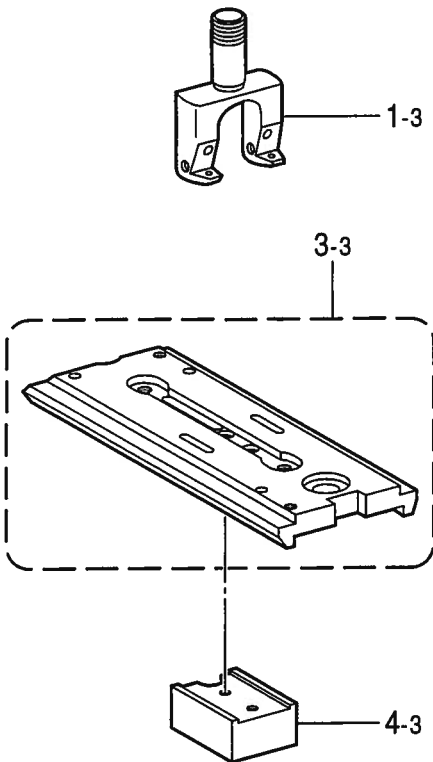

" 補給用部品 / For supply parts "

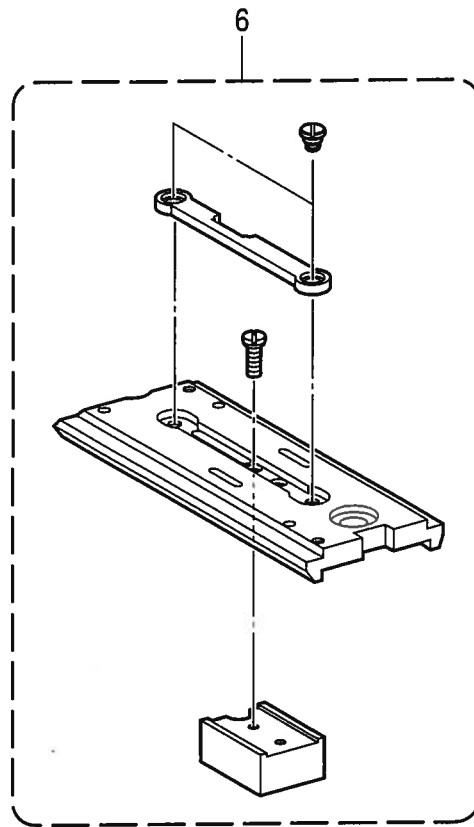

## G1.ゲージ関係 / Gauge parts

| REF.NO | CODE      | Q'TY | ヒンメイ                | NAME OF PARTS                                | RM |
|--------|-----------|------|---------------------|--|----|
| 1-1    | S59140001 | 1    | <国内用><br>ハリタキ10UPクミ | <For Japan only><br>NEEDLE CLAMP ASSY, 10 UP |    |
| 1-1-1  | 146427001 | 2    | アトメネジ 3.18クホミ       | SET SCREW, SOCKET (CP) SM3.18                |    |
| 3-1    | S52562001 | 1    | ハリタ10クミ             | NEEDLE PLATE ASSY, 10                        |    |
| 4-1    | S52537001 | 1    | ループガイド 10           | LOOP GUIDE, 10                               |    |
| 1-2    | S59141001 | 1    | <輸出用><br>ハリタキ12UPクミ | <For Export><br>NEEDLE CLAMP ASSY, 12 UP     |    |
| 1-2-1  | 146427001 | 2    | アトメネジ 3.18クホミ       | SET SCREW, SOCKET (CP) SM3.18                |    |
| 3-2    | S52563001 | 1    | ハリタ12クミ             | NEEDLE PLATE ASSY, 12                        |    |
| 4-2    | S52538001 | 1    | ループガイド 12           | LOOP GUIDE, 12                               |    |
| 5      | S21921001 | 2    | サラネジ 2.38X8         | SCREW, FLAT SM2.38X8                         |    |
| 7      | 153208002 | 2    | シメネジ 4.37           | SCREW, SM4.37-40X7                           |    |
| 8      | S52525001 | 1    | ハリタガイド              | GUIDE, N-PLATE                               |    |
| 9      | 153208002 | 2    | シメネジ 4.37           | SCREW, SM4.37-40X7                           |    |
| 1-3    | ※         | 1    | "オプション部品"<br>ハリタキクミ | "OPTION PARTS"<br>NEEDLE CLAMP ASSY          |    |
| 3-3    | ※         | 1    | ハリタクミ               | NEEDLE PLATE ASSY                            |    |
| 4-3    | ※         | 1    | ループガイド              | LOOP GUIDE, 10                               |    |
| 6      | ※         | 1    | "補給用部品"<br>ハリタセット   | "For Supply parts"<br>NEEDLE PLATE SET       |    |

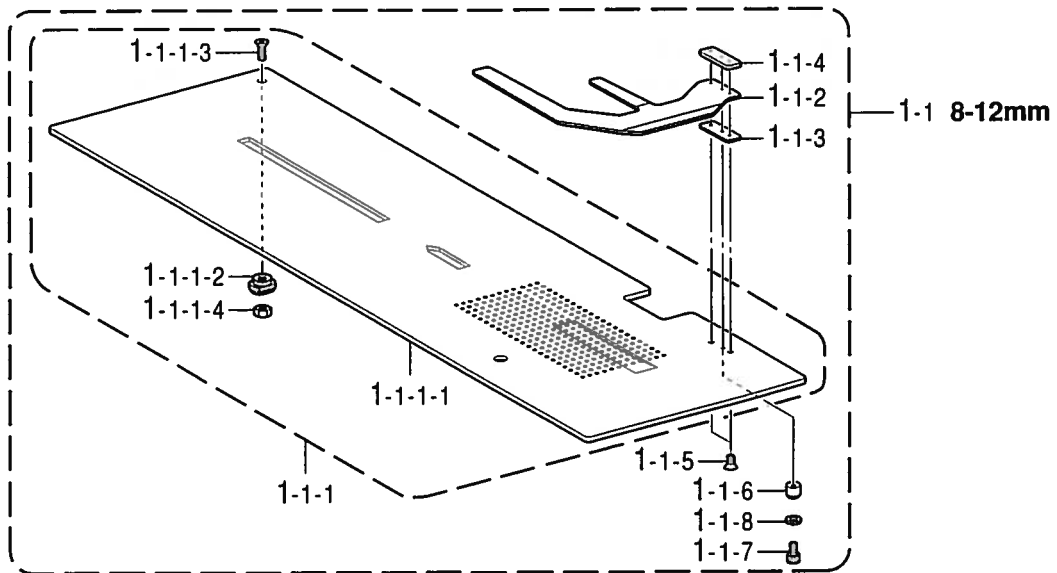

" オプション部品 / OPTION PARTS "

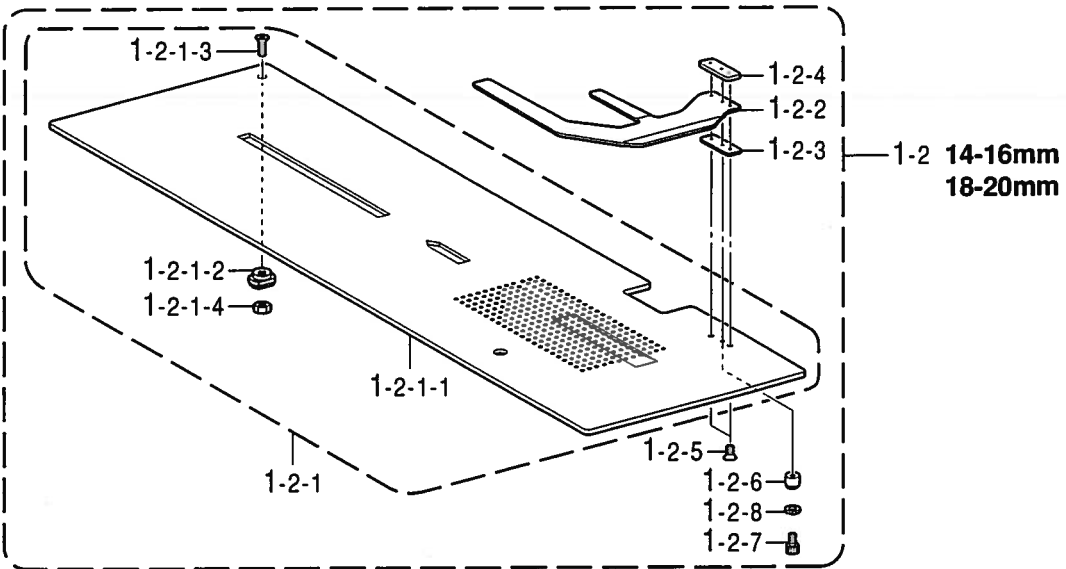

< 国内用 / For Japan only > 10mm

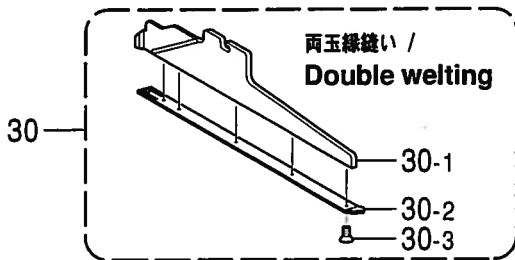

< 輸出用 / For Export > 12mm

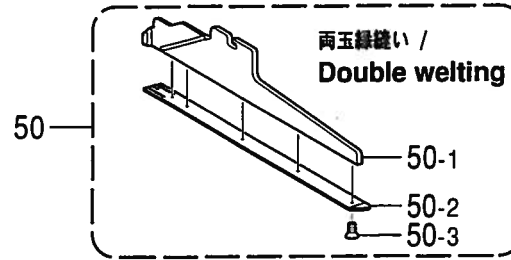

" 補給用部品 / For supply parts "

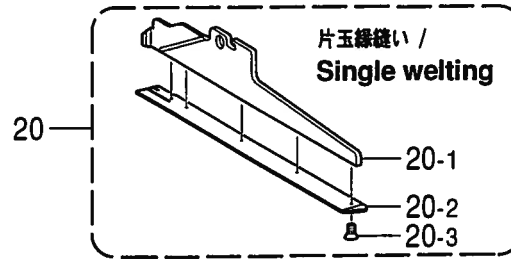
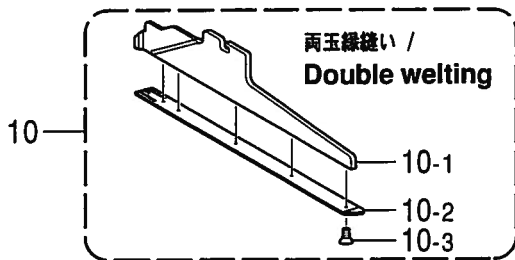

## G2.ゲージ関係 / Gauge parts

| REF.NO  | CODE      | QTY | ヒンメイ                                   | NAME OF PARTS           | RM |
|---------|-----------|-----|--|-------------------------|----|
| 1-1     | S58675000 | 1   | ス <sup>レ</sup> リイセツ8-12                | SLIDE PLATE SET, 8-12   |    |
| 1-1-1   | S53429000 | 1   | ス <sup>レ</sup> リイタクミ8-12               | SLIDE PLATE ASSY, 8-12  |    |
| 1-1-1-1 | S53430001 | 1   | キ <sup>ン</sup> ス <sup>レ</sup> リイタ      | SLIDE PLATE             |    |
| 1-1-1-2 | S53431001 | 1   | シ <sup>ン</sup> ピン                      | PIN                     |    |
| 1-1-1-3 | 004401414 | 1   | +サ <sup>ラ</sup> コ4X14                  | SCREW, FLAT M4X14       |    |
| 1-1-1-4 | 021400206 | 1   | 2シ <sup>ユ</sup> ナツト4                   | NUT, 2 M4               |    |
| 1-1-2   | S53432000 | 1   | セ <sup>パ</sup> レータ                     | SEPARATOR               |    |
| 1-1-3   | S53433000 | 1   | ス <sup>ペ</sup> -サA                     | SPACER, A               |    |
| 1-1-4   | S53434000 | 1   | ス <sup>ペ</sup> -サB                     | SPACER, B               |    |
| 1-1-5   | 004300513 | 2   | +サ <sup>ラ</sup> コ3X5                   | SCREW, FLAT M3X5        |    |
| 1-1-6   | S53518001 | 1   | イ <sup>チ</sup> キ <sup>メ</sup> カラ       | COLLAR                  |    |
| 1-1-7   | 018300836 | 1   | ア <sup>ナ</sup> ホルト3X8                  | BOLT, SOCKET M3X8       |    |
| 1-1-8   | 028030246 | 1   | ハ <sup>ネ</sup> サ <sup>ガ</sup> ネ2-3     | WASHER, SPRING 2-3      |    |
|         |           |     | <国内用標準>                                | <For Japan standard>    |    |
| 30      | S59275000 | 1   | ジ <sup>ョウ</sup> キ <sup>ク</sup> ミ10W-17 | -----                   |    |
| 30-1    | S59041000 | 1   | ジ <sup>ョウ</sup> キ <sup>W</sup> クミ      | -----                   |    |
| 30-2    | S54655000 | 1   | ジ <sup>ョウ</sup> キ <sup>10W-17</sup>    | -----                   |    |
| 30-3    | W01519001 | 5   | 0サ <sup>ラ</sup> コ3シ <sup>ユ</sup> 2X4   | -----                   |    |
|         |           |     | <輸出用>                                  | <For Export standard>   |    |
| 50      | S59279000 | 1   | ジ <sup>ョウ</sup> キ <sup>ク</sup> ミ12W-21 | BINDER ASSY, 12W-21     |    |
| 50-1    | S59041000 | 1   | ジ <sup>ョウ</sup> キ <sup>W</sup> クミ      | BINDER ASSY, W          |    |
| 50-2    | S54659000 | 1   | ジ <sup>ョウ</sup> キ <sup>12W-21</sup>    | BINDER, 12W-21          |    |
| 50-3    | W01519001 | 5   | 0サ <sup>ラ</sup> コ3シ <sup>ユ</sup> 2X4   | SCREW, FLAT #0 M2X4     |    |
|         |           |     | "オプション部品"                              | "OPTION PARTS"          |    |
| 1-2     | ※         | 1   | ス <sup>レ</sup> リイセツXX-YY               | SLIDE PLATE SET, XX-YY  |    |
| 1-2-1   | ※         | 1   | ス <sup>レ</sup> リイタクミXX-YY              | SLIDE PLATE ASSY, XX-YY |    |
| 1-2-1-1 | ※         | 1   | キ <sup>ン</sup> ス <sup>レ</sup> リイタ      | SLIDE PLATE             |    |
| 1-2-1-2 | S53431001 | 1   | シ <sup>ン</sup> ピン                      | PIN                     |    |
| 1-2-1-3 | 004401414 | 1   | +サ <sup>ラ</sup> コ4X14                  | SCREW, FLAT M4X14       |    |
| 1-2-1-4 | 021400206 | 1   | 2シ <sup>ユ</sup> ナツト4                   | NUT, 2 M4               |    |
| 1-2-3   | S53433000 | 1   | ス <sup>ペ</sup> -サA                     | SPACER, A               |    |
| 1-2-4   | S53434000 | 1   | ス <sup>ペ</sup> -サB                     | SPACER, B               |    |
| 1-2-5   | 004300513 | 2   | +サ <sup>ラ</sup> コ3X5                   | SCREW, FLAT M3X5        |    |
| 1-2-6   | S53518001 | 1   | イ <sup>チ</sup> キ <sup>メ</sup> カラ       | COLLAR                  |    |
| 1-2-7   | 018300836 | 1   | ア <sup>ナ</sup> ホルト3X8                  | BOLT, SOCKET M3X8       |    |
| 1-2-8   | 028030246 | 1   | ハ <sup>ネ</sup> サ <sup>ガ</sup> ネ2-3     | WASHER, SPRING 2-3      |    |
|         |           |     | "補給用部品"                                | "For Supply parts"      |    |
| 10      | ※         | 1   | ジ <sup>ョウ</sup> キ <sup>ク</sup> ミXXW-YY | BINDER ASSY, XXW-YY     |    |
| 10-1    | S59041000 | 1   | ジ <sup>ョウ</sup> キ <sup>W</sup> クミ      | BINDER ASSY, W          |    |
| 10-2    | ※         | 1   | ジ <sup>ョウ</sup> キ <sup>XXW-YY</sup>    | BINDER, XXW-YY          |    |
| 10-3    | W01519001 | 5   | 0サ <sup>ラ</sup> コ3シ <sup>ユ</sup> 2X4   | SCREW, FLAT #0 M2X4     |    |
| 20      | ※         | 1   | ジ <sup>ョウ</sup> キ <sup>ク</sup> ミXXS-YY | BINDER ASSY, XXS-YY     |    |
| 20-1    | S59042000 | 1   | ジ <sup>ョウ</sup> キ <sup>S</sup> クミ      | BINDER ASSY, S          |    |
| 20-2    | ※         | 1   | ジ <sup>ョウ</sup> キ <sup>XXS-YY</sup>    | BINDER, XXS-YY          |    |
| 20-3    | W01519001 | 5   | 0サ <sup>ラ</sup> コ3シ <sup>ユ</sup> 2X4   | SCREW, FLAT #0 M2X4     |    |

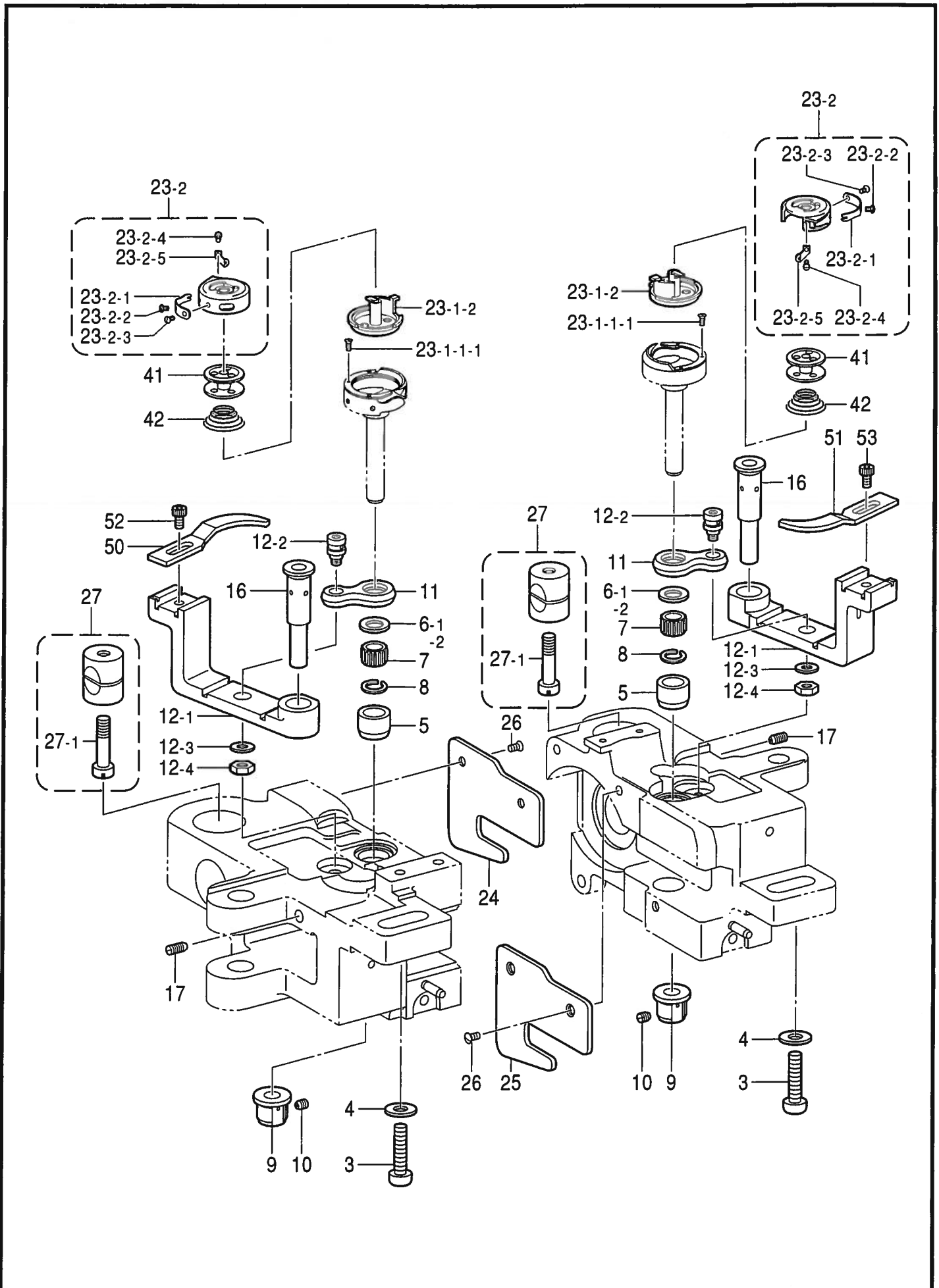



## H.カマ関係 / Rotary hook mechanism

| REF.NO   | CODE      | Q'TY | ヒンメイ         | NAME OF PARTS                 | RM |
|----------|-----------|------|--------------|-------------------------------|----|
| 3        | 062782512 | 2    | ナハコ635-28X25 | SCREW, PAN SM6.35-28X25       |    |
| 4        | 100197002 | 2    | サカネ          | WASHER                        |    |
| 5        | S09259001 | 2    | カマシクメタルU     | BUSH, U                       |    |
| 6-1      | S09260001 | 2    | スラストリングA     | THRUST RING, A ;1.2MM         |    |
| 6-2      | S09261001 | 2    | スラストリングB     | THRUST RING, B ;1.4MM         |    |
| 7        | S07420000 | 2    | ニートルハアリング    | NEEDLE BEARING                |    |
| 8        | S07419001 | 2    | ストツフリング      | RETAINING RING                |    |
| 9        | S07417001 | 2    | カマシクメタルD     | BUSH, D                       |    |
| 10       | 013710512 | 2    | トメネジ 4.76ホミ  | SET SCREW, (CP) SM4.76-32X5   |    |
| 11       | 150967101 | 2    | オープナリング      | OPENER LINK                   |    |
| 12-1     | S38213051 | 2    | オープナレバ-L     | OPENER LEVER, L               |    |
| 12-2     | 148005001 | 2    | オープナリングシク    | SHAFT, O-LINK                 |    |
| 12-3     | 025710232 | 2    | ヒラサカネチウ4.76  | WASHER, PLAIN M 4.76          |    |
| 12-4     | 110161006 | 2    | ナツト4.76      | NUT, SM4.76                   |    |
| 16       | S13021001 | 2    | オープナレバ-シク    | SHAFT, O-LEVER                |    |
| 17       | 013711012 | 2    | トメネジ 4.76ホミ  | SET SCREW, (CP) SM4.76-32X10  |    |
| 23       | S52675902 | 1    | ニホンハリカマハコクミ  | ROTARY FOOK ASSY, W/BOX       |    |
| 23-1-1-1 | 151027001 | 4    | ウチカマオサエトメネジ  | SET SCREW                     |    |
| 23-1-2   | S09273001 | 2    | ウチカマクミ       | INNER ROTARY HOOK ASSY        |    |
| 23-2     | S52677001 | 2    | キヤツクミ        | CAP ASSY                      |    |
| 23-2-1   | 155479001 | 2    | チヨウシハネ       | TENSION SPRING                |    |
| 23-2-2   | 151029001 | 2    | チヨウシネジ       | TENSION ADJUSTING SCREW       |    |
| 23-2-3   | 151030001 | 2    | チヨウシハネトメネジ   | SET SCREW                     |    |
| 23-2-4   | 159802001 | 2    | シメネジ 1.59X2  | SCREW, SM1.59X2               |    |
| 23-2-5   | S09284001 | 2    | シタイトホシタ      | HOLDING PLATE, ;L-THREAD      |    |
| 24       | S07436001 | 1    | キヤンナイL       | GEAR GUIDE, L                 |    |
| 25       | S07437001 | 1    | キヤンナイR       | GEAR GUIDE, R                 |    |
| 26       | 108960002 | 4    | サラネジ 3.57    | SCREW, FLAT SM3.57            |    |
| 27       | S07658001 | 2    | ピンチスリーブクミ    | PINCH SLEEVE ASSY             |    |
| 27-1     | 112700001 | 2    | シメネジ 5.95    | SCREW, SM5.95-28X32           |    |
| 41       | S09285051 | 2    | <標準用><br>ホビン | <Standard parts><br>BOBBIN, 2 |    |
| 42       | S09286000 | 2    | クウテンホウシハネ    | SPRING, ANTI-SPIN             |    |
| 50       | S38212001 | 1    | オープナ         | OPENER                        |    |
| 51       | S38212001 | 1    | オープナ         | OPENER                        |    |
| 52       | 154965001 | 1    | アナホルト3.57X8  | BOLT, SOCKET SM3.57X8         |    |
| 53       | 154965001 | 1    | アナホルト3.57X8  | BOLT, SOCKET SM3.57X8         |    |

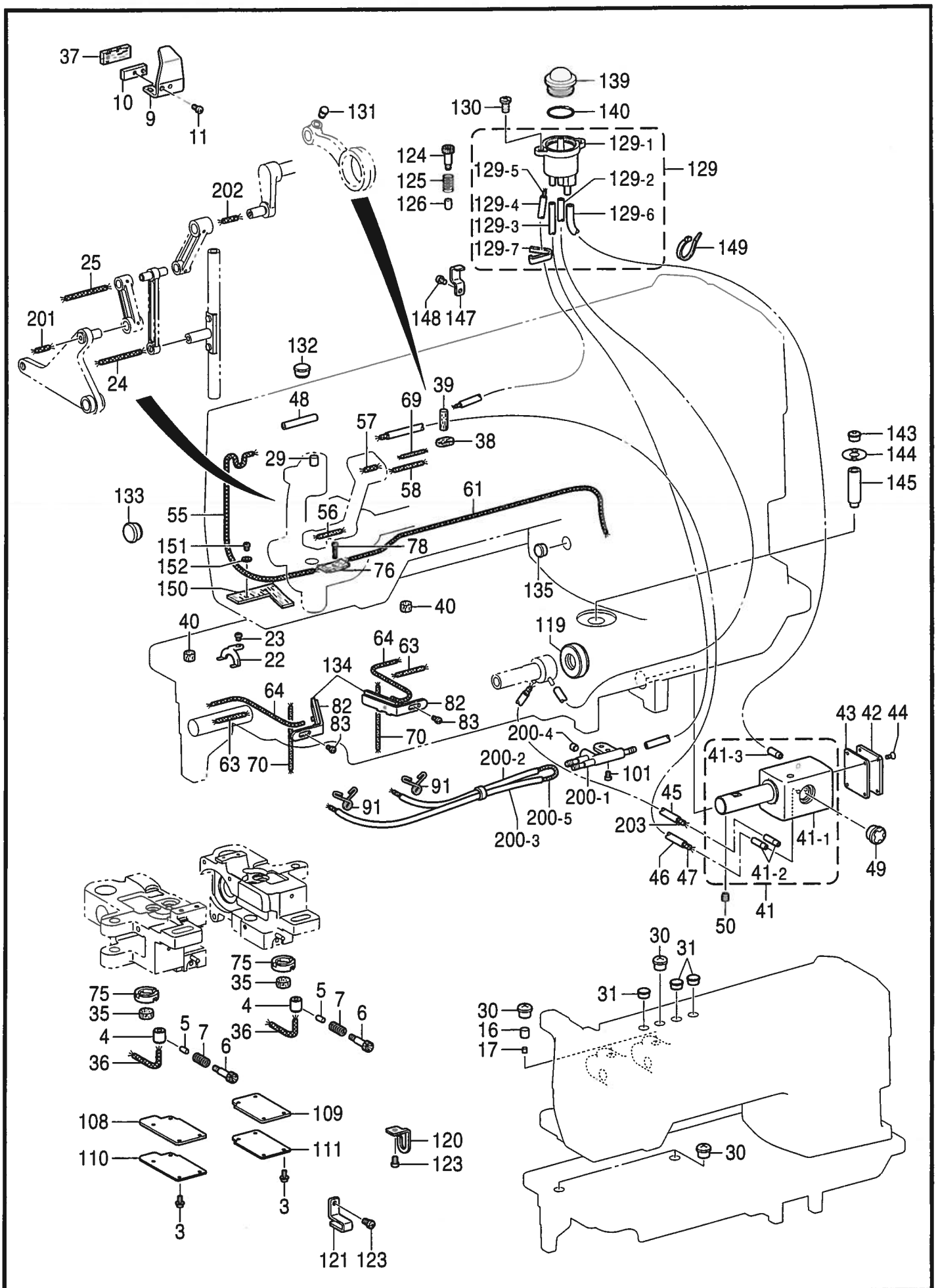

## J.給油潤滑関係 / Lubrication

| REF.NO | CODE      | Q'TY | ヒンメイ                                  | NAME OF PARTS                  | RM |
|--------|-----------|------|---------------------------------------|--------------------------------|----|
| 3      | S38248001 | 8    | ナ <sup>ハ</sup> サ <sup>ク</sup> ミ3.57X8 | SCREW, PAN (S/P WASHER) SM3.57 |    |
| 4      | S07477000 | 2    | ゴ <sup>ム</sup> リング                    | RUBBER RING                    |    |
| 5      | S07478000 | 2    | ゴ <sup>ム</sup> オサエ                    | RUBBER PRESSER                 |    |
| 6      | S38292001 | 2    | オイルチヨウセツネジ                            | OIL ADJUSTING SCREW            |    |
| 7      | S38299001 | 2    | オイルチヨウセツハ <sup>ネ</sup>                | OIL ADJUSTING SPRING           |    |
| 9      | 150988001 | 1    | オイルヨカイタ                               | OIL STOPPER PLATE              |    |
| 10     | 112717001 | 1    | オイルヨカイタオサエカネ                          | HOLDER, O-STOPPER PLATE        |    |
| 11     | 062711212 | 1    | ナ <sup>ハ</sup> コ476-32X12             | SCREW, PAN SM4.76-32X12        |    |
| 16     | 112753001 | 2    | フェルト                                  | FELT                           |    |
| 17     | S09043000 | 2    | フェルト                                  | FELT                           |    |
| 22     | S07471001 | 2    | ヒモササエ                                 | WICK HOLDER                    |    |
| 23     | 062670512 | 2    | ナ <sup>ハ</sup> コ357-40X5              | SCREW, PAN SM3.57-40X5         |    |
| 24     | S55770000 | 3    | クミヒモ4X4                               | WICK, L = 28                   |    |
| 25     | S55770000 | 3    | クミヒモ4X4                               | WICK, L = 28                   |    |
| 29     | 148394000 | 1    | ハリホ <sup>ウ</sup> セン                   | CAP, N-BAR                     |    |
| 30     | 140890009 | 5    | オイルカツフ                                | OIL CAP                        |    |
| 31     | 104821001 | 3    | ゴ <sup>ム</sup> セン10.5                 | RUBBER CAP, 10.5               |    |
| 35     | S38266000 | 2    | カマシ <sup>ク</sup> フェルト                 | FELT                           |    |
| 36     | S07476000 | 2    | フェルト                                  | FELT                           |    |
| 37     | 148762001 | 1    | テンヒ <sup>ン</sup> フェルト                 | FELT                           |    |
| 38     | S38269000 | 1    | ウワシ <sup>ク</sup> メタルフェルト              | FELT                           |    |
| 39     | S07571000 | 1    | フェルト                                  | FELT                           |    |
| 40     | 112753001 | 2    | フェルト                                  | FELT                           |    |
| 41     | S52550001 | 1    | オイルタンククミ                              | OIL TANK ASSY                  |    |
| 41-1   | S52551000 | 1    | オイルタンク                                | OIL TANK                       |    |
| 41-2   | S07333001 | 2    | オイルクチハ <sup>イ</sup> フ <sup>S</sup>    | PIPE, S                        |    |
| 41-3   | S52560001 | 1    | オイルクチハ <sup>イ</sup> フ <sup>L</sup>    | OIL FEEDING PIPE, L            |    |
| 42     | S52552000 | 1    | オイルタンクフタ                              | CAP, O-TANK                    |    |
| 43     | S52553000 | 1    | ハ <sup>ツ</sup> キン                     | PACKING                        |    |
| 44     | 004401003 | 4    | +サラネジ <sup>4</sup> X10                | SCREW, FLAT M4X10              |    |
| 45     | S52556000 | 1    | ビ <sup>ニ</sup> ルチューブ                  | OIL TUBE, L=340                |    |
| 46     | S52557000 | 1    | ビ <sup>ニ</sup> ルチューブ                  | OIL TUBE, L=580                |    |
| 47     | S52558000 | 1    | クミヒモ                                  | WICK, L=730                    |    |
| 48     | S52559000 | 1    | ビ <sup>ニ</sup> ルチューブ                  | OIL TUBE                       |    |
| 49     | 152948001 | 1    | オイルホ <sup>ツ</sup> マト                  | OIL WINDOW                     |    |
| 50     | 013710512 | 1    | トメネジ <sup>4.76</sup> クホ <sup>ミ</sup>  | SET SCREW, (CP) SM4.76-32X5    |    |
| 55     | S07465000 | 1    | クミヒモ                                  | WICK, L=200                    |    |
| 56     | 112728001 | 1    | クミヒモ                                  | WICK, L=50                     |    |
| 57     | 114693001 | 1    | クミヒモ                                  | WICK, L=30                     |    |
| 58     | 112735000 | 1    | クミヒモ                                  | WICK, L=45                     |    |
| 58     | 112735000 | 1    | クミヒモ                                  | WICK, L=45                     |    |
| 61     | S53195000 | 1    | クミヒモ                                  | WICK                           |    |
| 63     | S38481000 | 2    | クミヒモ                                  | WICK, L=41                     |    |
| 64     | 108802001 | 2    | クミヒモ4X4                               | WICK, 4X4 L=250                |    |
| 69     | S07462000 | 1    | クミヒモ                                  | WICK, L=25                     |    |
| 70     | S07463000 | 2    | クミヒモ                                  | WICK, L=70                     |    |
| 75     | S38541000 | 2    | オイルリング                                | OIL RING                       |    |
| 76     | S48734000 | 1    | フェルトD                                 | FELT, D                        |    |
| 78     | 062671412 | 1    | ナ <sup>ハ</sup> コ357-40X14             | SCREW, PAN SM3.57-40X14        |    |
| 82     | S21195001 | 2    | フェルトオサエ                               | FELT SUPPORT                   |    |
| 83     | 062670512 | 2    | ナ <sup>ハ</sup> コ357-40X5              | SCREW, PAN SM3.57-40X5         |    |
| 91     | S07876101 | 7    | チューブ <sup>ス</sup> ツハ <sup>ハ</sup>     | TUBE CLIP                      |    |
| 101    | 062670612 | 2    | ナ <sup>ハ</sup> コ357-40X6              | SCREW, PAN SM3.57-40X6         |    |
| 108    | S48737000 | 1    | カマト <sup>ダイ</sup> ハ <sup>ツ</sup> キンR  | PACKING, R                     |    |
| 109    | S48738000 | 1    | カマト <sup>ダイ</sup> ハ <sup>ツ</sup> キンL  | PACKING, L                     |    |
| 110    | S48739001 | 1    | カマト <sup>ダイ</sup> フ <sup>タ</sup> R    | CAP, R                         |    |
| 111    | S48740001 | 1    | カマト <sup>ダイ</sup> フ <sup>タ</sup> L    | CAP, L                         |    |
| 119    | S38251000 | 1    | オイルシール                                | OIL SEAL                       |    |
| 120    | S38261001 | 1    | チューブ <sup>ト</sup> オン <sup>ル</sup>     | TUBE SUPPORT BRACKET, L        |    |
| 121    | S38264001 | 1    | オイルチューブ <sup>サ</sup> サ <sup>エ</sup>   | OIL TUBE SUPPORT               |    |
| 123    | 062710612 | 2    | ナ <sup>ハ</sup> コ476-32X6              | SCREW, PAN SM4.76-32X6         |    |

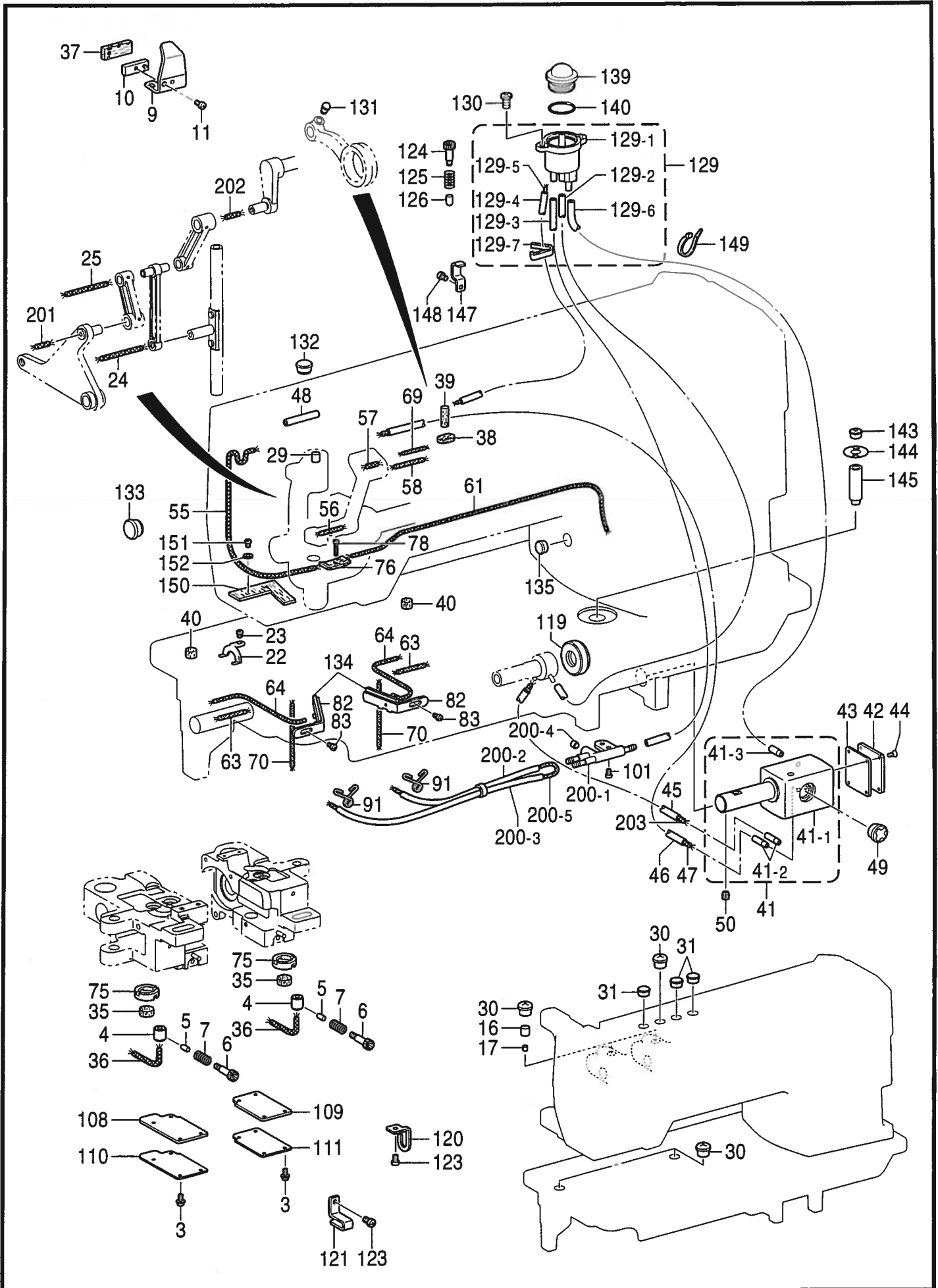

## J.給油潤滑関係 / Lubrication

| REF.NO | CODE      | Q'TY | ヒンメイ           | NAME OF PARTS            | RM |
|--------|-----------|------|----------------|--------------------------|----|
| 124    | S38292001 | 1    | オイルヨウセツネジ      | OIL ADJUSTING SCREW      |    |
| 125    | S38299001 | 1    | オイルヨウセツハネ      | OIL ADJUSTING SPRING     |    |
| 126    | S07478000 | 1    | ゴムオサヒ          | RUBBER PRESSER           |    |
| 129    | S52679001 | 1    | オイルキタシケース      | OIL CASE ASSY            |    |
| 129-1  | S48763001 | 1    | オイルキタシケース      | OIL CASE                 |    |
| 129-2  | S53175000 | 1    | フキチューブ         | OIL TUBE, L=450          |    |
| 129-3  | S53176000 | 1    | ビニールチューブD      | OIL TUBE, D ;L=355       |    |
| 129-4  | S53177000 | 1    | ビニールチューブU      | OIL TUBE, U ;L=170       |    |
| 129-5  | S53178000 | 1    | クミヒモ4X4        | WICK, L=300              |    |
| 129-6  | S53179000 | 1    | ドレンチューブ        | DRAIN TUBE, L=300        |    |
| 129-7  | S07469001 | 1    | チューブカシメ        | TUBE CALKING             |    |
| 130    | 060681212 | 2    | ハインド 437-40X12 | SCREW, BIND SM4.37-40X12 |    |
| 131    | 111865001 | 1    | セン6            | CAP, 6                   |    |
| 132    | S49564002 | 1    | ゴムセン12.5       | RUBBER CAP, 12.5         |    |
| 133    | 117934001 | 1    | ゴムセン13.5       | RUBBER CAP, 13.5         |    |
| 134    | S21196001 | 2    | フェルト           | FELT                     |    |
| 135    | 104821001 | 1    | ゴムセン10.5       | RUBBER CAP, 10.5         |    |
| 139    | S02606000 | 1    | ユリヨウケイマ        | OIL GAUGE WINDOW         |    |
| 140    | 081014670 | 1    | リングPW14        | O RING, PW14             |    |
| 143    | 112758001 | 1    | ハットオイルフタ       | OIL CAP                  |    |
| 144    | S07481009 | 1    | オイルシート         | OIL MARK SHEET           |    |
| 145    | S53184001 | 1    | キウユクチ          | OIL TUBE JOINT           |    |
| 147    | S07327001 | 1    | コードオサヒ         | CORD HOLDER, L           |    |
| 148    | 062670512 | 1    | ナベコ357-40X5    | SCREW, PAN SM3.57-40X5   |    |
| 149    | S04557000 | 1    | バンドPLT1M       | BAND, PLT1M              |    |
| 150    | S55898000 | 1    | フェルト           | FELT                     |    |
| 151    | 062670612 | 1    | ナベコ357-40X6    | SCREW, PAN SM3.57-40X6   |    |
| 152    | 025040135 | 1    | ヒラサガネシヨウ4      | WASHER, PLAIN S 4        |    |
| 200    | S54993001 | 1    | キウユクタミナルクミ     | TERMINAL ASSY            |    |
| 200-1  | S14189100 | 1    | ターミナル          | TERMINAL                 |    |
| 200-2  | S38448000 | 1    | ビニールチューブ       | OIL TUBE, L=200          |    |
| 200-3  | S07459100 | 1    | ビニールチューブ       | OIL TUBE, L=240          |    |
| 200-4  | 142274101 | 1    | ゴムセン4.2        | RUBBER CAP, 4.2          |    |
| 200-5  | S07464100 | 1    | クミヒモ           | WICK, L=530              |    |
| 201    | S55769000 | 1    | クミヒモ4X4        | WICK, 4X4                |    |
| 202    | S55769000 | 1    | クミヒモ4X4        | WICK, 4X4                |    |
| 203    | S55304000 | 1    | クミヒモ4X4        | WICK, 4X4                |    |

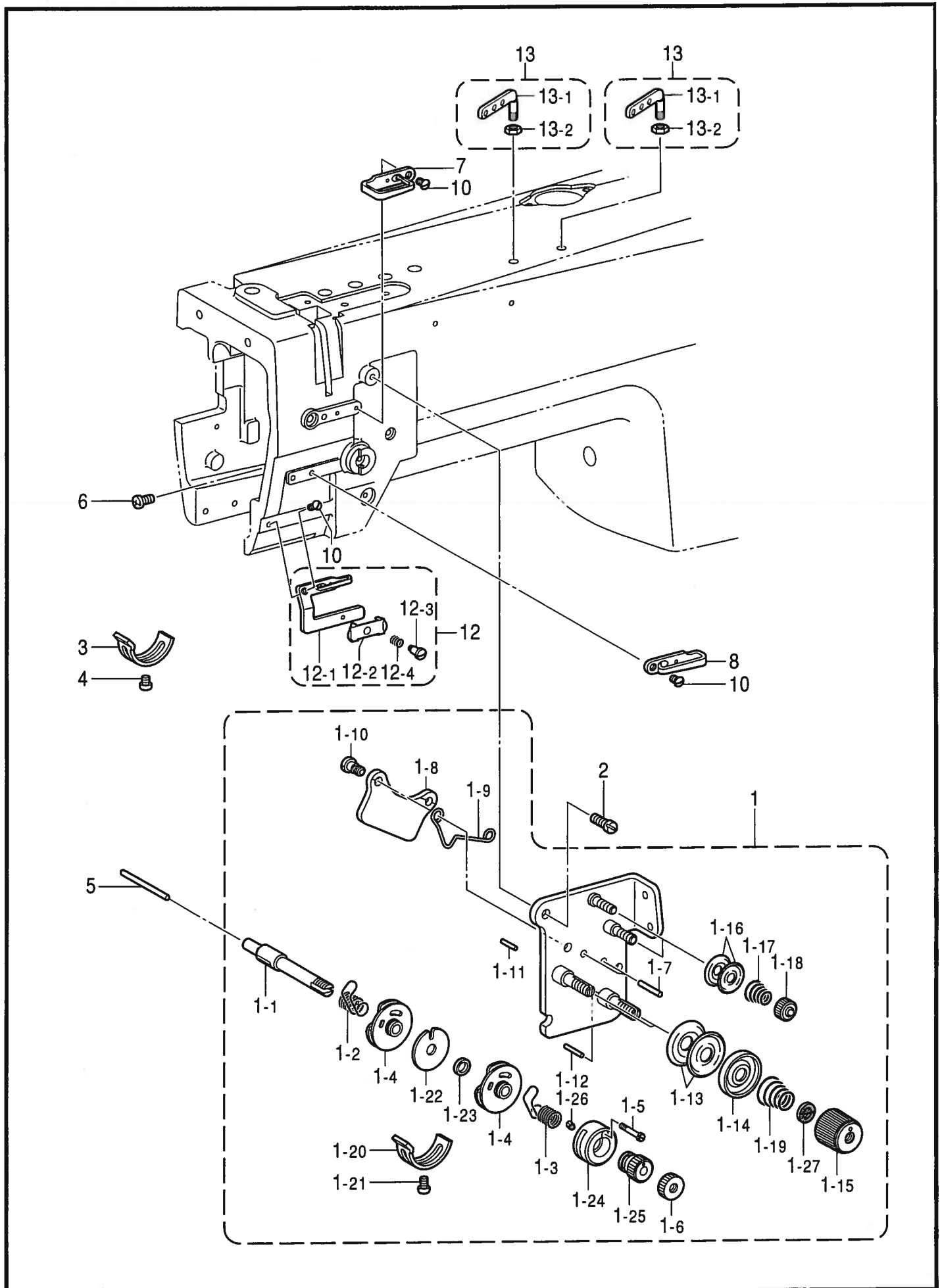

K.糸通し関係 / Threading mechanism

| REF.NO | CODE      | Q'TY | ヒンメイ                                    | NAME OF PARTS                 | RM |
|--------|-----------|------|---|-------------------------------|----|
| 1      | S15584509 | 1    | ウワイトチヨウシクミ                              | UPPER THREAD TENSION ASSY, D  |    |
| 1-1    | S08604001 | 1    | チヨウシク                                   | TENSION STUD                  |    |
| 1-2    | S08607001 | 1    | イトトリハ <sup>レ</sup>                      | THREAD TAKE-UP SPRING, L      |    |
| 1-3    | S08608001 | 1    | イトトリハ <sup>レ</sup>                      | THREAD TAKE-UP SPRING, R      |    |
| 1-4    | 108254001 | 2    | イトトリハ <sup>レ</sup> ネアンナイクミ              | GUIDE ASSY, ;T/TAKE-UP SPRING |    |
| 1-5    | 146124001 | 1    | シメネジ <sup>レ</sup> 2.38                  | SCREW, SM2.38                 |    |
| 1-6    | 108265009 | 1    | イトチヨウシナツト                               | TENSION NUT                   |    |
| 1-7    | 158768001 | 2    | ピン2.6X20                                | PIN, 2.6X20                   |    |
| 1-8    | S07487101 | 1    | イトユルメイタ                                 | TENSION RELEASE PLATE         |    |
| 1-9    | S38274001 | 1    | イトユルメハ <sup>レ</sup> ネ                   | SPRING, T-RELEASE             |    |
| 1-10   | 112712001 | 2    | ダンネジ <sup>レ</sup> 3.57                  | SHOULDER SCREW, SM3.57        |    |
| 1-11   | S07488001 | 1    | イトユルヒ <sup>レ</sup> ンL                   | TENSION RELEASE PIN, L        |    |
| 1-12   | 158769001 | 1    | イトユルヒ <sup>レ</sup> ンR                   | TENSION RELEASE PIN, R        |    |
| 1-13   | 145446001 | 4    | イトチヨウシサラ                                | DISC, TENSION                 |    |
| 1-14   | 159805001 | 2    | イトチヨウシサラオサエ                             | DISC PRESSER, ;TENSION        |    |
| 1-15   | 149566109 | 2    | イトチヨウシナツト                               | TENSION NUT                   |    |
| 1-16   | 144504001 | 4    | イトアンナイサラ                                | DISC, THREAD GUIDE            |    |
| 1-17   | 154560001 | 2    | プレテンションハ <sup>レ</sup> ネA                | SPRING, ;PRE-TENSION (A)      |    |
| 1-18   | 155510001 | 2    | イトチヨウシナツト                               | TENSION NUT                   |    |
| 1-19   | S07490001 | 2    | イトチヨウシハ <sup>レ</sup> ネ                  | TENSION SPRING                |    |
| 1-20   | 112709001 | 1    | イトトリハ <sup>レ</sup> ネストツハ <sup>レ</sup>   | STOPPER                       |    |
| 1-21   | 062670512 | 1    | ナ <sup>レ</sup> コ357-40X5                | SCREW, PAN SM3.57-40X5        |    |
| 1-22   | S08605101 | 1    | スパ <sup>レ</sup> サー                      | SPACER                        |    |
| 1-23   | S08606001 | 1    | カラ <sup>レ</sup>                         | COLLAR                        |    |
| 1-24   | S08609201 | 1    | ストツハ <sup>レ</sup> ウケ                    | STOPPER SUPPORT               |    |
| 1-25   | S08610101 | 1    | チヨウセツツマミ                                | ADJUSTING THUMB               |    |
| 1-26   | 013660612 | 1    | トメネジ <sup>レ</sup> 3.18クホ <sup>レ</sup> ミ | SET SCREW, (CP) SM3.18        |    |
| 1-27   | 151148001 | 2    | MLマワリト <sup>レ</sup> メ                   | STOPPER, ML                   |    |
| 2      | 100064002 | 1    | シメネジ <sup>レ</sup> 3.57                  | SCREW, SM3.57X8               |    |
| 3      | 112709001 | 1    | イトトリハ <sup>レ</sup> ネストツハ <sup>レ</sup>   | STOPPER                       |    |
| 4      | 062670512 | 1    | ナ <sup>レ</sup> コ357-40X5                | SCREW, PAN SM3.57-40X5        |    |
| 5      | S14677001 | 1    | イトコルメジク                                 | TENSION RELEASE SHAFT         |    |
| 6      | 062680812 | 1    | ナ <sup>レ</sup> コ437-40X8                | SCREW, PAN SM4.37-40X8        |    |
| 7      | 108266001 | 1    | ア <sup>レ</sup> ムイトアンナイU                 | THREAD GUIDE, U ;ARM          |    |
| 8      | S54023001 | 1    | ア <sup>レ</sup> ムイトアンナイM                 | THREAD GUIDE, M               |    |
| 10     | 108960002 | 3    | サラネジ <sup>レ</sup> 3.57                  | SCREW, FLAT SM3.57            |    |
| 12     | S49529001 | 1    | ア <sup>レ</sup> ムイトアンナイDクミ               | THREAD GUIDE ASSY, D          |    |
| 12-1   | S48760001 | 1    | ア <sup>レ</sup> ムイトアンナイD                 | THREAD GUIDE, D               |    |
| 12-2   | S48761001 | 1    | ハリイトオサエ                                 | THREAD CLAMP                  |    |
| 12-3   | 112301001 | 1    | ダンネジ <sup>レ</sup> 3.18                  | SHOULDER SCREW, SM3.18        |    |
| 12-4   | S49530001 | 1    | ハリイトアンナイオンハ <sup>レ</sup> ネ              | SPRING, COMPRESSION           |    |
| 13     | S30505001 | 2    | ミツメイトカケクミ                               | THREAD RETAINER ASSY          |    |
| 13-1   | 140527001 | 2    | ミツメイトカケ                                 | THREAD RETAINER               |    |
| 13-2   | 150553003 | 2    | ナツト5.95                                 | NUT, SM5.95                   |    |

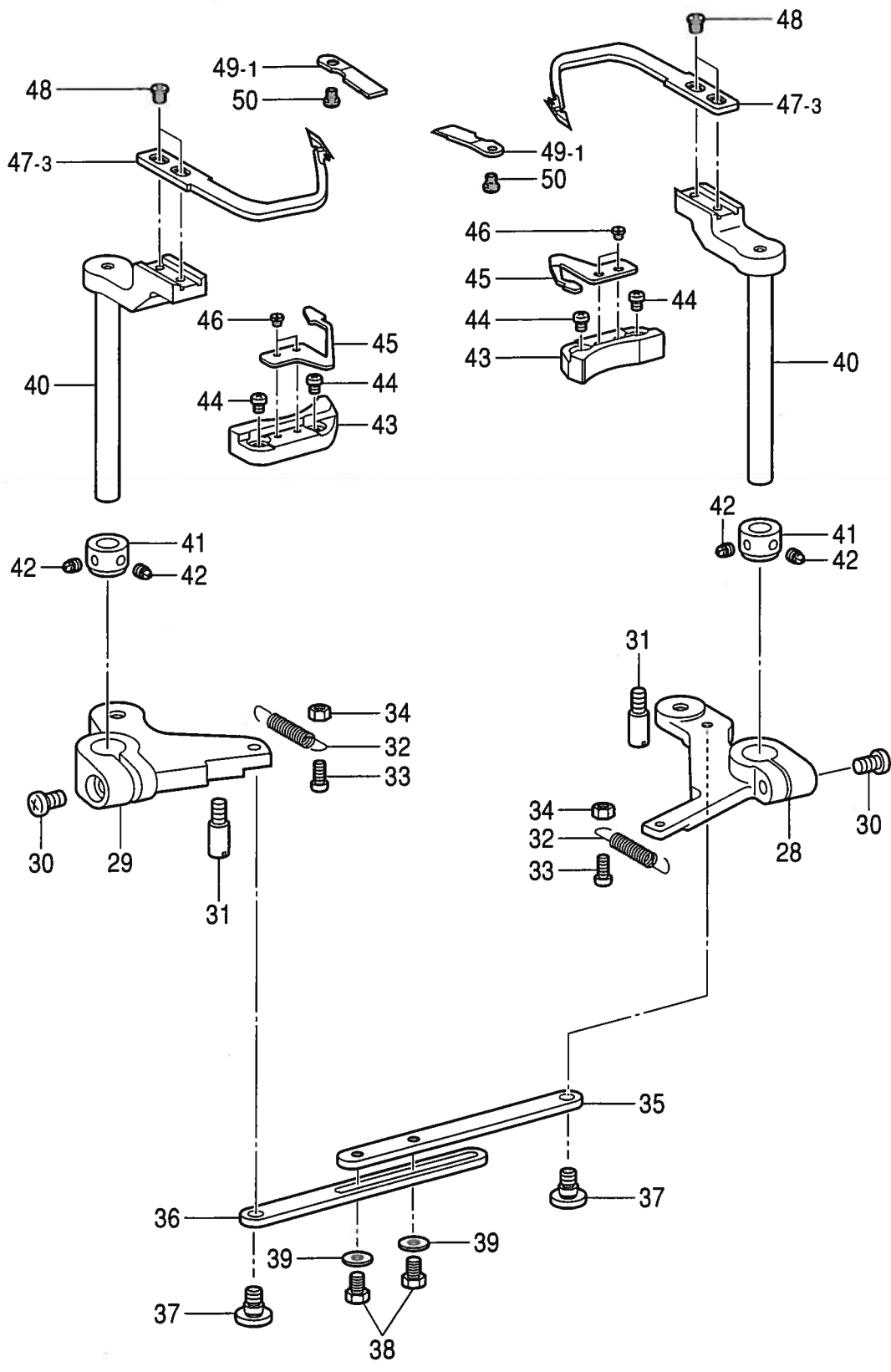



## L1.糸切り関係 / Thread trimmer mechanism

| REF.NO | CODE      | Q'TY | ヒンメイ        | NAME OF PARTS                 | RM |
|--------|-----------|------|-------------|-------------------------------|----|
| 28     | S38419001 | 1    | トキリハ-R      | THREAD TRIMMER LEVER, R       |    |
| 29     | S38420001 | 1    | トキリハ-L      | THREAD TRIMMER LEVER, L       |    |
| 30     | 062681212 | 2    | ナコ37-40X12  | SCREW, PAN SM4.37-40X12       |    |
| 31     | S07519001 | 2    | ストップネジ4.76  | STOPPER SCREW, SM4.76         |    |
| 32     | S07520001 | 2    | トキリハハネ      | SPRING, EXTENSION             |    |
| 33     | 062671412 | 2    | ナコ357-40X14 | SCREW, PAN SM3.57-40X14       |    |
| 34     | 021670102 | 2    | ナットシユ3.57   | NUT, 1 SM3.57                 |    |
| 35     | S07521001 | 1    | トキリレンカR     | CONNECTING ROD, R ;TR         |    |
| 36     | S07522001 | 1    | トキリレンカL     | CONNECTING ROD, L ;TR         |    |
| 37     | 144526001 | 2    | タネネジ4.37    | SHOULDER SCREW, SM4.37        |    |
| 38     | 146360002 | 2    | ホルト4.76X7   | BOLT, SM4.76X7                |    |
| 39     | 025710232 | 2    | ヒラサカネジユ4.76 | WASHER, PLAIN M 4.76          |    |
| 40     | S53172001 | 2    | トウハレハ-      | LEVER, M-KNIFE                |    |
| 41     | 120752001 | 2    | セットカラ-      | SET SCREW COLLAR              |    |
| 42     | 100251001 | 4    | トメネジ6.35    | SET SCREW, (CP) SM6.35-40X6.5 |    |
| 43     | S07524101 | 2    | トウハウケ       | MOVABLE KNIFE BRACKET         |    |
| 44     | 062670812 | 4    | ナコ3.57-40X8 | SCREW, PAN SM3.57-40X8        |    |
| 45     | S07525000 | 2    | シタイトホシハネ    | SPRING, PLATE                 |    |
| 46     | 141544001 | 4    | シメネジ3.18    | SCREW, SM3.18-40X3            |    |
| 47-3   | S52549001 | 2    | トウハ         | MOVABLE KNIFE                 |    |
| 48     | 148536001 | 4    | シメネジ4.37    | SCREW, W/SOCKET SM4.37-40X4.2 |    |
| 49-1   | S07527001 | 2    | コテイハ        | FIXED KNIFE                   |    |
| 50     | 148539101 | 2    | タネネジ2.38    | SHOULDER SCREW, SM2.38        |    |

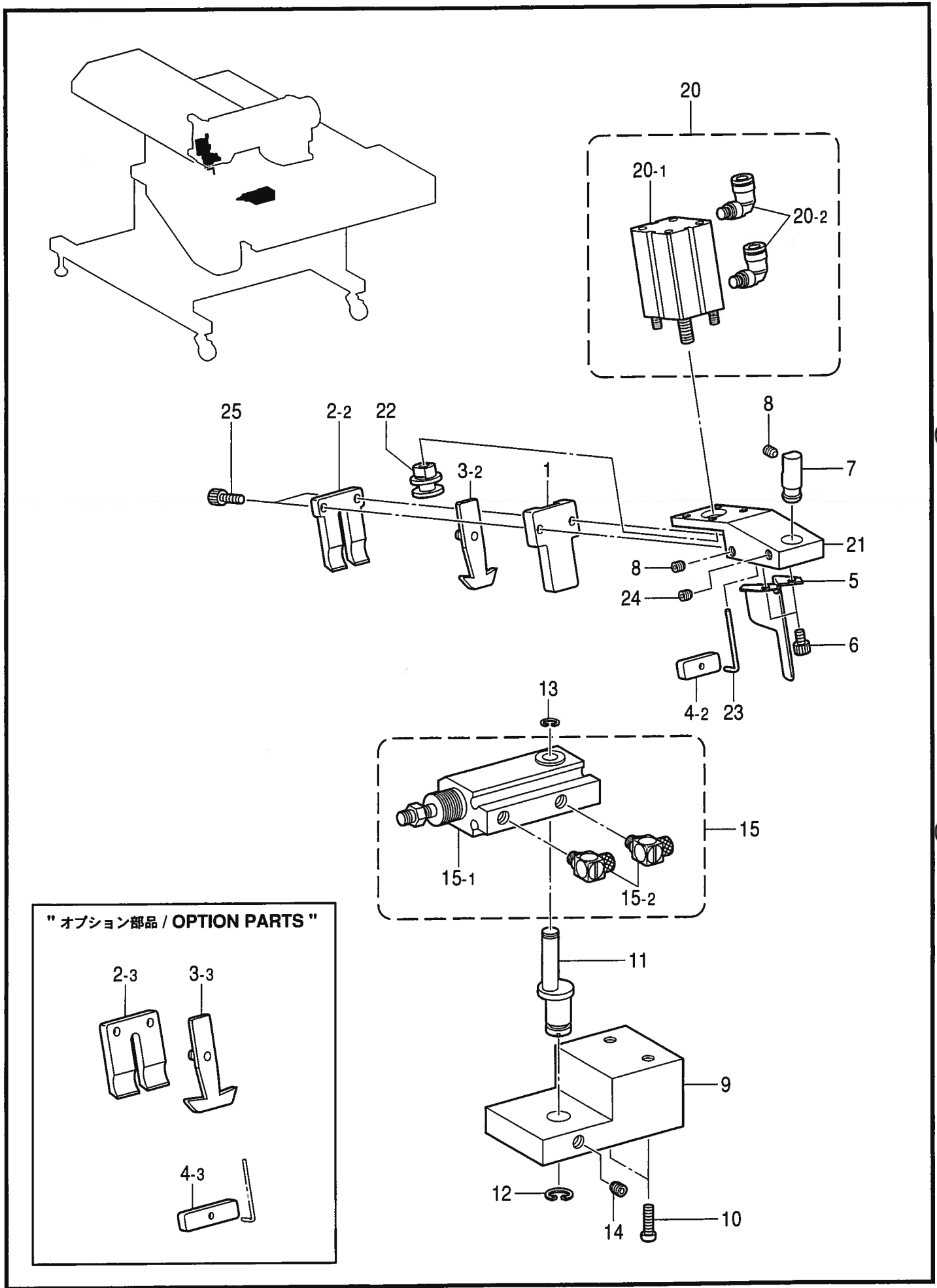

" オプション部品 / OPTION PARTS "

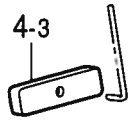
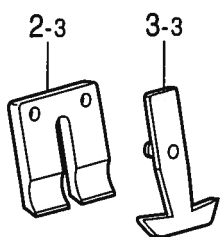

## L2.糸切り関係 / Thread trimmer mechanism

| REF.NO | CODE      | Q'TY | ヒンメイ           | NAME OF PARTS                | RM |
|--------|-----------|------|----------------|------------------------------|----|
| 1      | S59235001 | 1    | ウメスカ` 卜`       | KNIFE GUIDE                  |    |
| 2-2    | S53494001 | 1    | コテイハ10-12      | FIXED KNIFE, 10-12           |    |
| 3-2    | S53498001 | 1    | ウワトメス10-12クミ   | N/THREAD KNIFE ASSY, 10-12   |    |
| 4-2    | S53507001 | 1    | 卜ホジ` 卜10-12    | THREAD HOLDING PLATE, 10-12  |    |
| 5      | S59032000 | 1    | キシ` カキ         | GUIDE PLATE                  |    |
| 6      | 018300636 | 2    | アナホル` 卜3X6     | BOLT, SOCKET M3X6            |    |
| 7      | S53512101 | 1    | 卜キリリツケシ` ク     | SETTING SHAFT                |    |
| 8      | 012500536 | 2    | アナヒラ5X5        | SET SCREW, SOCKET (FT) M5X5  |    |
| 9      | S53513001 | 1    | 卜キリシリンダ` タ` イ  | CYLINDER BASE                |    |
| 10     | 062682012 | 2    | ナハ` コ437-40X20 | SCREW, PAN SM4.37-40X20      |    |
| 11     | S53514001 | 1    | シリンダ` シテンシ` ク  | ECCENTRIC SHAFT              |    |
| 12     | 048100142 | 1    | トメワジ` クヨウC10   | RETAINING RING, EXTERNAL C10 |    |
| 13     | 048060142 | 1    | トメワジ` クヨウ C6   | RETAINING RING, C6           |    |
| 14     | 012060636 | 1    | アナヒラ6X6        | SET SCREW, SOCKET (FT) M6X6  |    |
| 15     | S53515000 | 1    | シリンダ`-クミ       | CYLINDER ASSY                |    |
| 15-1   | S53516000 | 1    | エアシリンダ` 15X20  | AIR CYLINDER, 15X20          |    |
| 15-2   | S16603000 | 2    | コテイシホ` リツキエルホ` | TUBE ELBOW, W/VALVE          |    |
| 20     | S59155000 | 1    | シリンダ`-クミ       | CYLINDER ASSY                |    |
| 20-1   | S59156000 | 1    | エアシリンダ` 12X25  | AIR CYLINDER, 12X25          |    |
| 20-2   | S53488000 | 2    | ツキ` テ          | JOINT                        |    |
| 21     | S59036001 | 1    | 卜キリリツケタ` イ     | SETTING BASE                 |    |
| 22     | S59158001 | 1    | 卜キリカラ`         | COLLAR                       |    |
| 23     | S53492001 | 1    | 卜ホジ` ハ` ネ      | SPRING                       |    |
| 24     | 012500536 | 1    | アナヒラ5X5        | SET SCREW, SOCKET (FT) M5X5  |    |
| 25     | 018301236 | 2    | アナホル` 卜3X12    | BOLT, SOCKET M3X12           |    |
|        |           |      | "オプション部品"      | "OPTION PARTS"               |    |
| 2-3    | ※         | 1    | コテイハXX-YY      | FIXED KNIFE, XX-YY           |    |
| 3-3    | ※         | 1    | ウワトメスXX-YYクミ   | N/THREAD KNIFE ASSY, XX-YY   |    |
| 4-3    | ※         | 1    | 卜ホジ` 卜XX-YY    | THREAD HOLDING PLATE, XX-YY  |    |

M. 糸緩メ関係 / Tension release mechanism

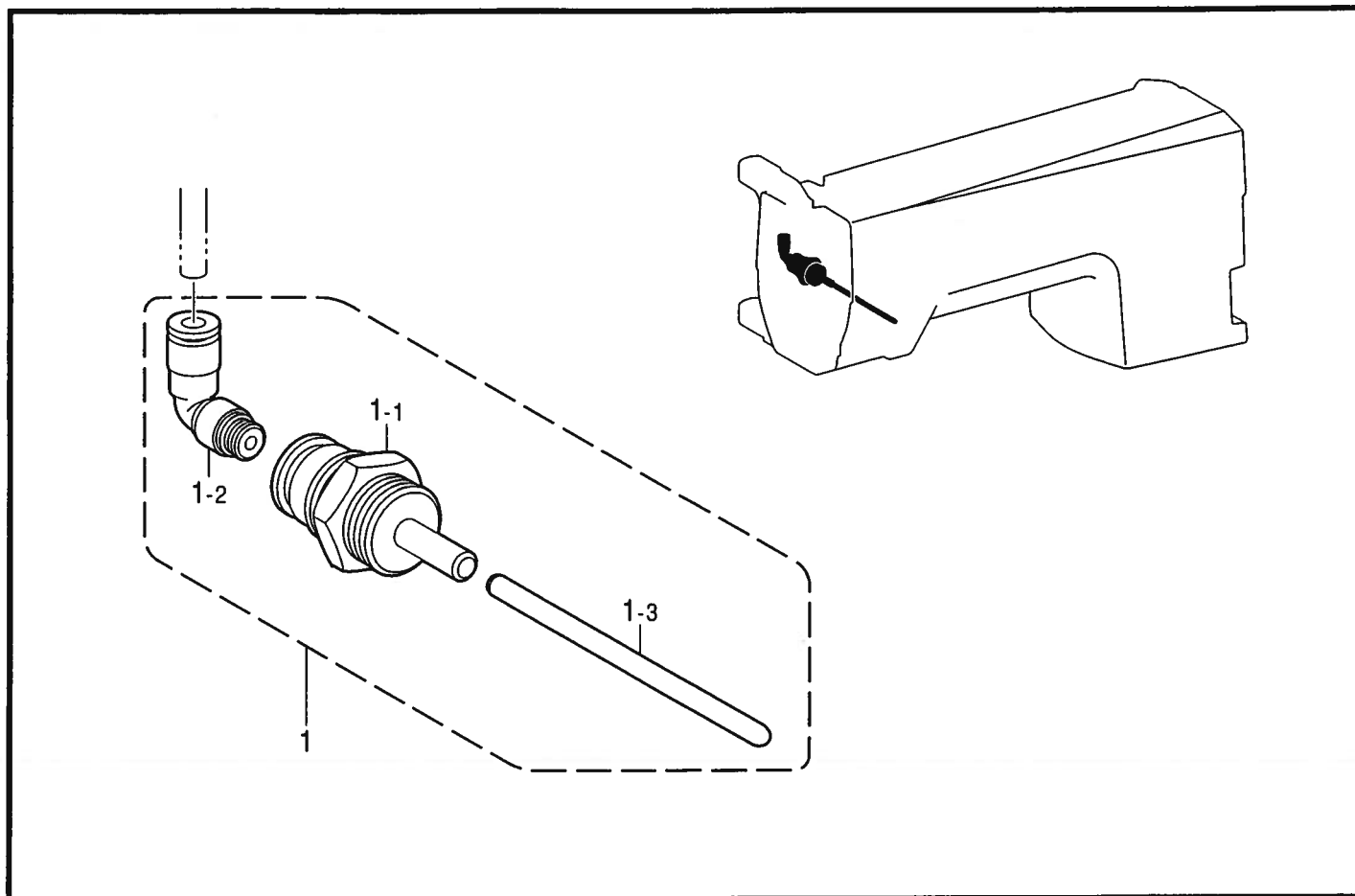

118-U73-404

N. モータ関係 / Motor mechanism

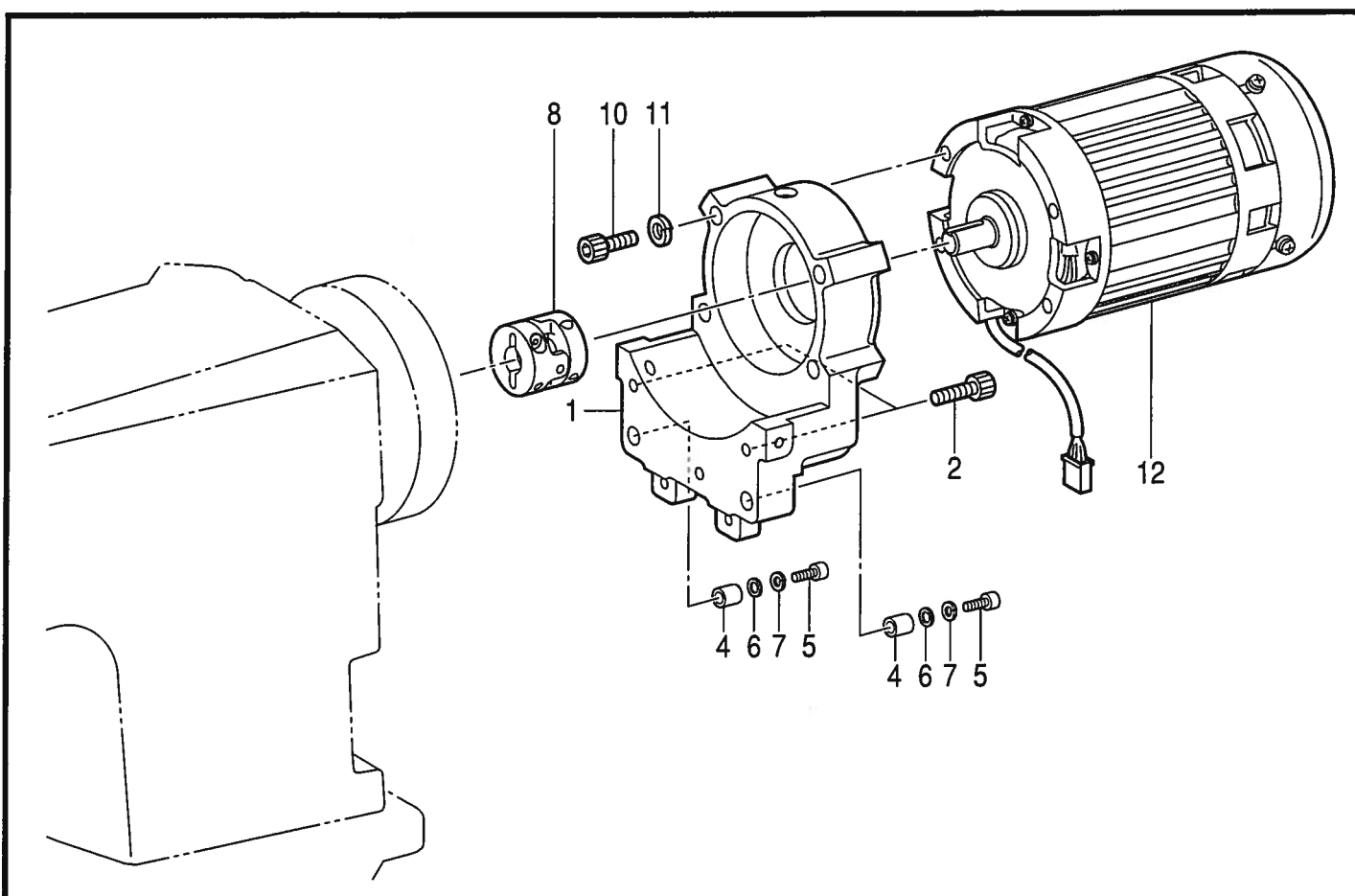

118-U73-650

## M.系緩め関係 / Tension release mechanism

| REF.NO | CODE      | Q'TY | ヒンメイ      | NAME OF PARTS         | RM |
|--------|-----------|------|-----------|-----------------------|----|
| 1      | S53171000 | 1    | シリンダクミ    | CYLINDER ASSY         |    |
| 1-1    | S15097000 | 1    | シリンダ 10X5 | CYLINDER, 10X5        |    |
| 1-2    | S53488000 | 1    | ツキテ       | JOINT                 |    |
| 1-3    | S14677001 | 1    | トコルメジク    | TENSION RELEASE SHAFT |    |

118-U73-404

## N.モータ関係 / Motor mechanism

| REF.NO | CODE      | Q'TY | ヒンメイ        | NAME OF PARTS           | RM |
|--------|-----------|------|-------------|-------------------------|----|
| 1      | S52493001 | 1    | トウブモ-タブラケット | MOTOR BRACKET, H        |    |
| 2      | 018063036 | 3    | アナルト6X30    | BOLT, SOCKET M6X30      |    |
| 4      | 152914001 | 2    | コロ          | ROLLER                  |    |
| 5      | S59357001 | 2    | トルクスM4-20   | BOLT, TORX SOCKET M4X20 |    |
| 6      | 100645003 | 2    | ワッシャ        | WASHER                  |    |
| 7      | 028040246 | 2    | ハネサカネ2-4    | WASHER, SPRING 2-4      |    |
| 8      | S53166000 | 1    | カツリンク 14X15 | COUPLING, 14X15         |    |
| 10     | 018062536 | 4    | アナルト6X25    | BOLT, SOCKET M6X25      |    |
| 11     | 028060246 | 4    | ハネサカネ2-6    | WASHER, SPRING 2-6      |    |
| 12     | J80869001 | 1    | CIMモ-タタマクミホ | MOTOR ASSY, CIM         |    |

118-U73-650

P. 下糸検出関係 (オプション部品) / Lower thread detector mechanism (Option parts)

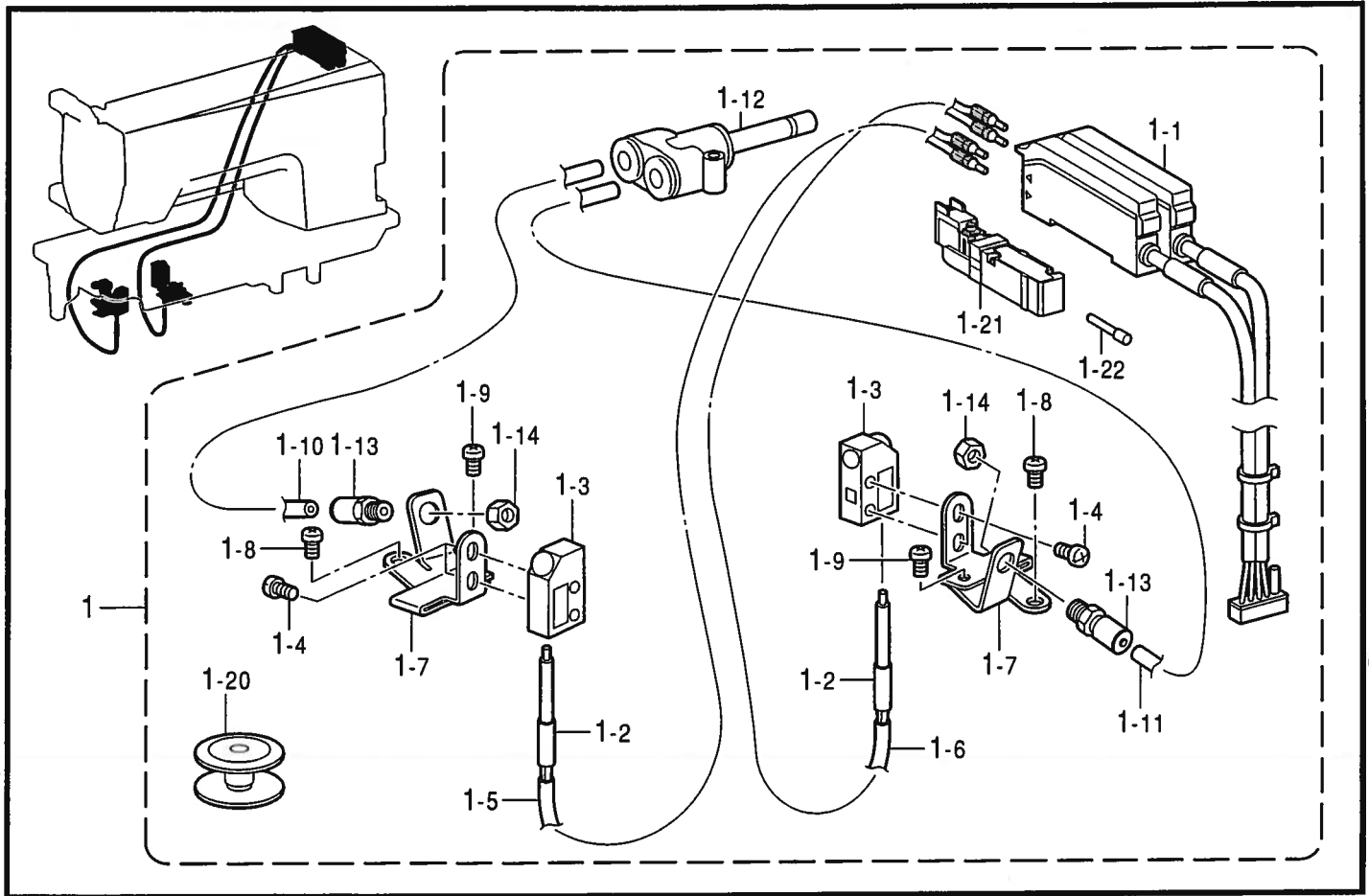

151-615-213

Q. 糸切れ感知関係 (オプション部品) / Thread breakage detector mechanism (Option parts)

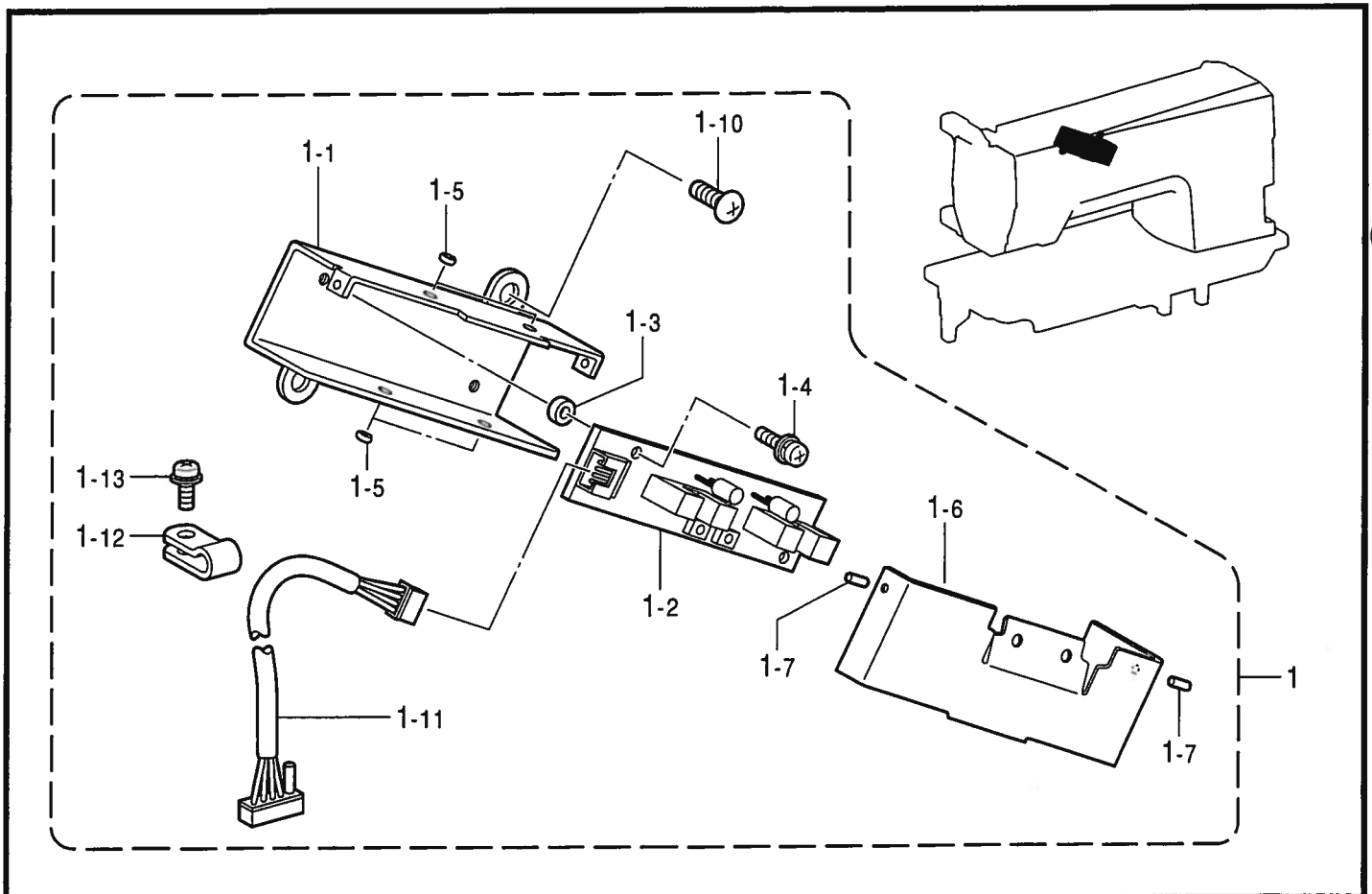

151-615-219

P.下系検出関係(オプション部品) / Lower thread detector mechanism (Option parts)

| REF.NO | CODE      | Q'TY | ヒンメイ            | NAME OF PARTS             | RM |
|--------|-----------|------|-----------------|---------------------------|----|
| 1      | S59371001 | 1    | シタイトケンシユツセンサクミ  | DETECTOR SENSOR ASSY      |    |
| 1-1    | S52469000 | 1    | シタイトケンシユツセンサ    | DETECTOR SENSOR, L-THREAD |    |
| 1-2    | S52961000 | 2    | ファイバFD-G4       | FIBER, FD-G4              |    |
| 1-3    | S52962000 | 2    | サイドレンズFX-MR5    | SIDE LENS                 |    |
| 1-4    | 062300606 | 4    | ナヘコ3X6          | SCREW, PAN M3X6           |    |
| 1-5    | S53421000 | 1    | ヒニルチューブ950      | TUBE, L=950               |    |
| 1-6    | S53423000 | 1    | ヒニルチューブ700      | TUBE, L=700               |    |
| 1-7    | S53422000 | 2    | サンリヨウセンサホルダ     | SENSOR HOLDER             |    |
| 1-8    | 062300606 | 2    | ナヘコ3X6          | SCREW, PAN M3X6           |    |
| 1-9    | 062300606 | 2    | ナヘコ3X6          | SCREW, PAN M3X6           |    |
| 1-10   | S53617000 | 1    | エアホース0604U0085B | AIR TUBE, 0604U0085B      |    |
| 1-11   | S53618000 | 1    | エアホース0604U0080B | AIR TUBE, 0604U0080B      |    |
| 1-12   | S53978000 | 1    | ブランチユニオンY       | BRANCH, Y                 |    |
| 1-13   | S11433000 | 2    | ホースニツブル4M5      | HOSE NIPPLE, 4M5          |    |
| 1-14   | 021500316 | 2    | 3シユナツト5         | NUT, 3 M5                 |    |
| 1-20   | S52490001 | 2    | ホビン             | BOBBIN                    |    |
| 1-21   | S39115100 | 1    | バルブVQZ2151-5    | VALVE, VQZ2151-5          |    |
| 1-22   | S53983000 | 1    | プラグ4            | PLUG, 4                   |    |

151-615-213

Q.糸切れ感知関係(オプション部品) / Thread breakage detector mechanism (Option parts)

| REF.NO | CODE      | Q'TY | ヒンメイ          | NAME OF PARTS                | RM |
|--------|-----------|------|---------------|------------------------------|----|
| 1      | S53425001 | 1    | イトキレセンサBOXクミ  | THREAD BREAKAGE BOX ASSY     |    |
| 1-1    | S53426001 | 1    | センサトメタ        | FIXING PLATE, SENSOR         |    |
| 1-2    | S52966000 | 1    | イトキレセンサキハシクミ  | SENSOR PCB ASSY              |    |
| 1-3    | S52758000 | 2    | スハサEP-3       | SPACER, EP-3                 |    |
| 1-4    | 0A4300805 | 2    | ナヘサクミ3X8DA    | SCREW, PAN (S/P WASHER) M3X8 |    |
| 1-5    | 117436001 | 4    | テンピンイトミチ      | THREAD GUIDE                 |    |
| 1-6    | S53427001 | 1    | センサホコフタ       | PROTECTOR CAP                |    |
| 1-7    | 047200642 | 2    | スプリングピンAW2    | PIN, SPRING ROLL AW2         |    |
| 1-10   | 008400804 | 2    | トラスコ4X8       | SCREW, TRUSS M4X8            |    |
| 1-11   | S52462000 | 1    | イトキレセンサハーネス   | SENSOR HARNESS, S-M/PCB      |    |
| 1-12   | S10243000 | 1    | ナイロンクランプNK-3N | CORD HOLDER, ;NK-3N          |    |
| 1-13   | 0A5400805 | 1    | ナヘサクミ4X8DB    | SCREW, PAN (S/P WASHER) M4X8 |    |

151-615-219

R. スタッカー関係 (オプション部品) / Stacker mechanism (Option parts)

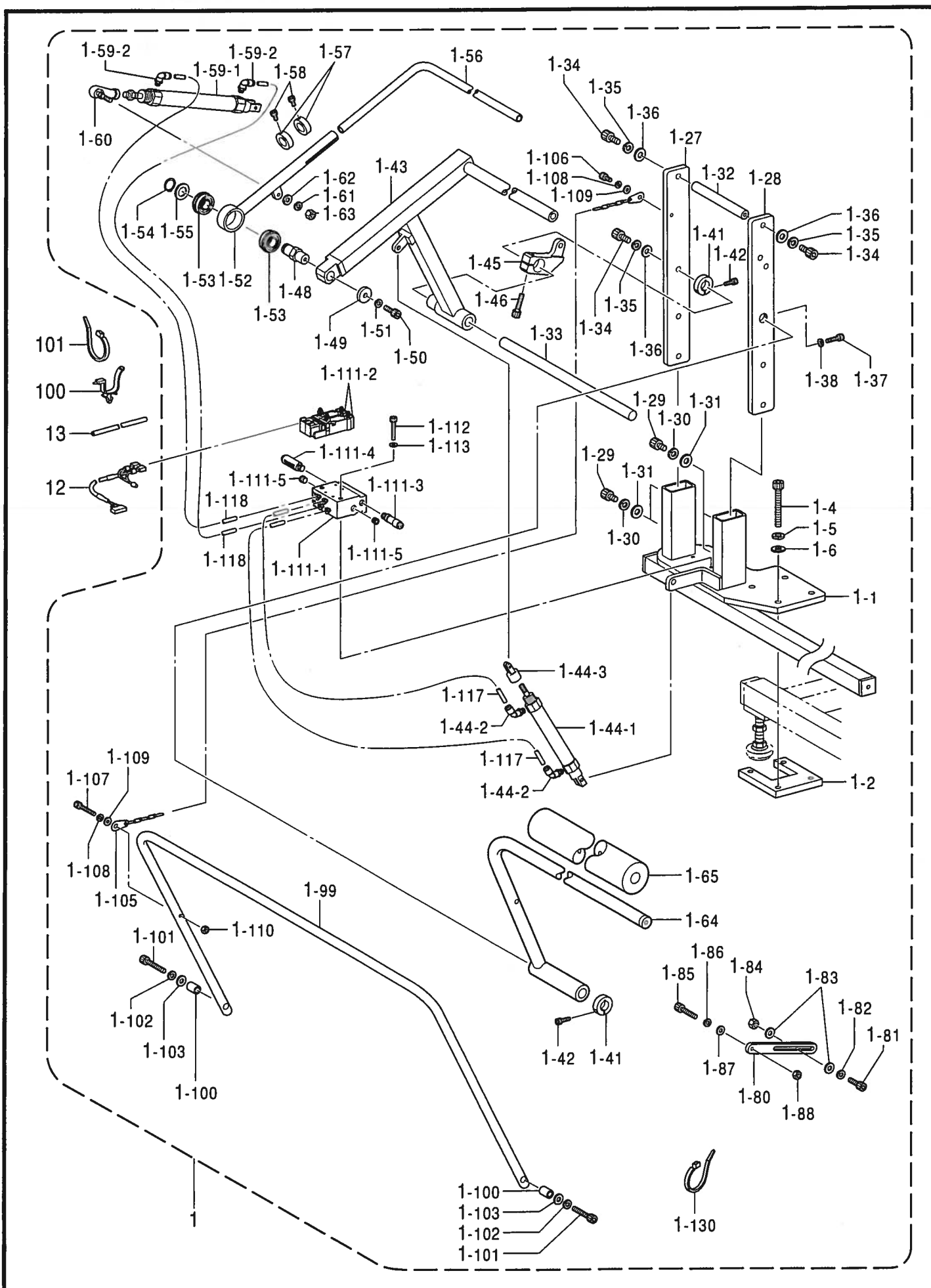



## R.スタッカー関係(オプション部品) / Stacker mechanism (Option parts)

| REF.NO | CODE      | Q'TY | ヒンメイ          | NAME OF PARTS                | RM |
|--------|-----------|------|---------------|------------------------------|----|
| 1      | S58179001 | 1    | バースタツカクミ      | BAR STACKER ASSY, L          |    |
| 1-1    | S58180001 | 1    | スタツカ-ベース      | STACKER BASE                 |    |
| 1-2    | S54115001 | 1    | タツフプレート       | TAP PLATE                    |    |
| 1-4    | 018108036 | 4    | アナボルト10X80    | SCREW, SOCKET M10X80         |    |
| 1-5    | 028100246 | 4    | ハネサガネ2-10     | WASHER, SPRING 2-10          |    |
| 1-6    | 025100236 | 4    | ヒラサガネチユウ10    | WASHER, PLAIN L 10           |    |
| 1-27   | S54123001 | 1    | コテイプレートL      | FIXING PLATE, L              |    |
| 1-28   | S54122001 | 1    | コテイプレートR      | FIXING PLATE, R              |    |
| 1-29   | 018102036 | 4    | アナボルト10X20    | BOLT, SOCKET M10X20          |    |
| 1-30   | 028100246 | 4    | ハネサガネ2-10     | WASHER, SPRING 2-10          |    |
| 1-31   | 025100236 | 4    | ヒラサガネチユウ10    | WASHER, PLAIN L 10           |    |
| 1-32   | S54108001 | 1    | ハバキメシヤフト      | SHAFT, L=126                 |    |
| 1-33   | S54117001 | 1    | リンクシテンシク      | FULCRUM SHAFT                |    |
| 1-34   | 018082036 | 3    | アナボルト8X20     | BOLT, SOCKET M8X20           |    |
| 1-35   | 028080246 | 3    | ハネサガネ2-8      | WASHER, SPRING 2-8           |    |
| 1-36   | 025080236 | 3    | ヒラサガネチユウ8     | WASHER, PLAIN M 8            |    |
| 1-37   | 018502036 | 1    | アナボルト5X20     | BOLT, SOCKET M5X20           |    |
| 1-38   | 028050246 | 1    | ハネサガネ2-5      | WASHER, SPRING 2-5           |    |
| 1-41   | S54596000 | 2    | セットカラ-        | SET SCREW COLLAR             |    |
| 1-42   | 018501622 | 2    | アナボルト5X16     | BOLT, SOCKET M5X16           |    |
| 1-43   | S54140001 | 1    | クランプリンク       | CLAMP LINK                   |    |
| 1-44   | S54137000 | 1    | シリンダークミ       | CYLINDER ASSY                |    |
| 1-44-1 | S54136000 | 1    | エアシリンダー20X100 | AIR CYLINDER, 20X100         |    |
| 1-44-2 | S53981000 | 2    | エルボKQ2L0601S  | ELBOW, KQWL0601S             |    |
| 1-44-3 | S54135000 | 1    | ナツクルシヨイント     | KNUCKLE JOINT                |    |
| 1-45   | S54118001 | 1    | シリンダーホルダー     | CYLINDER HOLDER              |    |
| 1-46   | 018063036 | 1    | アナボルト6X30     | BOLT, SOCKET M6X30           |    |
| 1-48   | S54126001 | 1    | シテンシヤフト       | SHAFT                        |    |
| 1-49   | S54127001 | 1    | エンドプレート       | END PLATE                    |    |
| 1-50   | 018081636 | 1    | アナボルト8X16     | BOLT, SOCKET M8X16           |    |
| 1-51   | 028080246 | 1    | ハネサガネ2-8      | WASHER, SPRING 2-8           |    |
| 1-52   | S54120001 | 1    | ハライリンク        | WIPER LINK                   |    |
| 1-53   | S54595000 | 2    | タマシクウケ        | BALL BEARING, 6004DDUNR      |    |
| 1-54   | 048200142 | 1    | トメワシクヨウC20    | RETAINING RING, EXTERNAL C20 |    |
| 1-55   | S46191001 | 1    | スベサ           | SPACER                       |    |
| 1-56   | S54119001 | 1    | ハライパイプ        | PIPE                         |    |
| 1-57   | S54106001 | 2    | ホルダー          | HOLDER                       |    |
| 1-58   | 018061036 | 2    | アナボルト6X10     | BOLT, SOCKET M6X10           |    |
| 1-59   | S59031000 | 1    | シリンダークミ       | CYLINDER ASSY                |    |
| 1-59-1 | S54592000 | 1    | エアシリンダー20X150 | AIR CYLINDER, 20X150         |    |
| 1-59-2 | S53981000 | 2    | エルボKQ2L0601S  | ELBOW, KQWL0601S             |    |
| 1-60   | S54594000 | 1    | ロッドエンド        | ROD END                      |    |
| 1-61   | 028080246 | 1    | ハネサガネ2-8      | WASHER, SPRING 2-8           |    |
| 1-62   | 025080236 | 1    | ヒラサガネチユウ8     | WASHER, PLAIN M 8            |    |
| 1-63   | 021080206 | 1    | 2シユナツト8       | NUT, 2 M8                    |    |
| 1-64   | S58181001 | 1    | スタツカテーブル      | STACKER TABLE                |    |
| 1-65   | S58182100 | 1    | テーブルゴム        | STACKER RUBBER               |    |
| 1-80   | S54130001 | 1    | レンケツリンクB      | CONNECTING LINK, B           |    |
| 1-81   | 018083036 | 1    | アナボルト8X30     | BOLT, SOCKET M8X30           |    |
| 1-82   | 028080246 | 1    | ハネサガネ2-8      | WASHER, SPRING 2-8           |    |
| 1-83   | 025080236 | 2    | ヒラサガネチユウ8     | WASHER, PLAIN M 8            |    |
| 1-84   | 021080206 | 1    | 2シユナツト8       | NUT, 2 M8                    |    |
| 1-85   | 018064036 | 1    | アナボルト6X40     | BOLT, SOCKET M6X40           |    |
| 1-86   | 028060246 | 1    | ハネサガネ2-6      | WASHER, SPRING 2-6           |    |
| 1-87   | 025060236 | 2    | ヒラサガネチユウ6     | WASHER, PLAIN M 6            |    |
| 1-88   | 021060206 | 1    | 2シユナツト6       | NUT, 2 M6                    |    |
| 1-99   | S54132001 | 1    | ガード           | GUARD                        |    |
| 1-100  | S54133001 | 2    | パイプカラ-        | PIPE COLLAR                  |    |
| 1-101  | 018083036 | 2    | アナボルト8X30     | BOLT, SOCKET M8X30           |    |
| 1-102  | 028080246 | 2    | ハネサガネ2-8      | WASHER, SPRING 2-8           |    |
| 1-103  | 025080236 | 2    | ヒラサガネチユウ8     | WASHER, PLAIN M 8            |    |

R. スタッカー関係 (オプション部品) / Stacker mechanism (Option parts)

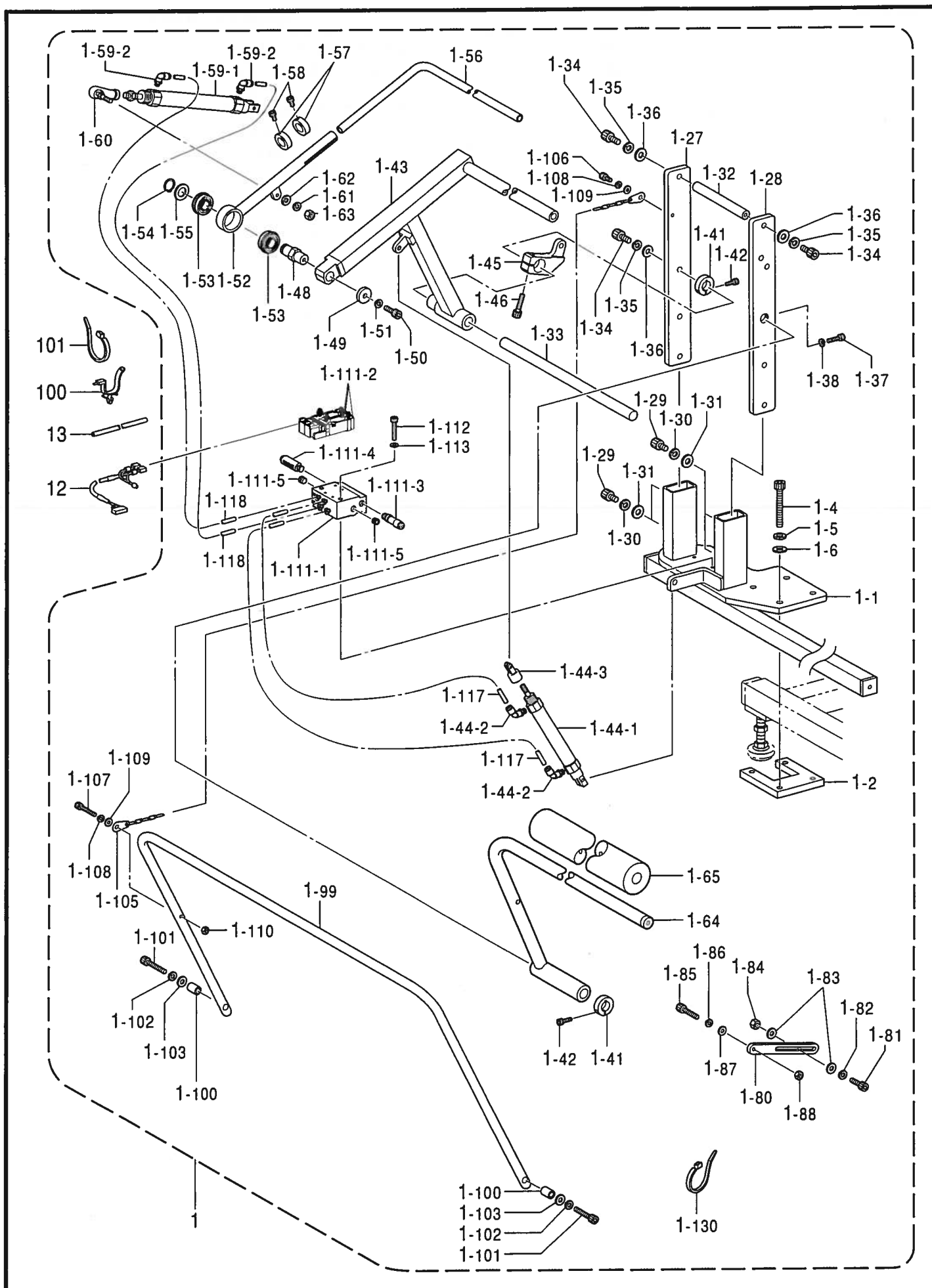

## R.スタッカー関係(オプション部品) / Stacker mechanism (Option parts)

| REF.NO  | CODE      | Q'TY | ヒンメイ  | NAME OF PARTS       | RM |
|---------|-----------|------|---|---------------------|----|
| 1-105   | S54605000 | 1    | クサリ   | CHAIN               |    |
| 1-106   | 018061236 | 1    | アホ <sup>ホ</sup> ルト6X12                              | BOLT, SOCKET M6X12  |    |
| 1-107   | 018063036 | 1    | アホ <sup>ホ</sup> ルト6X30                              | BOLT, SOCKET M6X30  |    |
| 1-108   | 028060246 | 2    | ハ <sup>ネ</sup> サ <sup>カ</sup> ネ2-6                  | WASHER, SPRING 2-6  |    |
| 1-109   | 025060236 | 2    | ヒラサ <sup>カ</sup> ネユウ6                               | WASHER, PLAIN M 6   |    |
| 1-110   | 021060206 | 1    | 2 <sup>シ</sup> ユナツト6                                | NUT, 2 M6           |    |
| 1-111   | S58183000 | 1    | ハ <sup>ル</sup> フ <sup>エ</sup> ニツト2                  | VALVE UNIT, 2       |    |
| 1-111-1 | S58184000 | 1    | マニホ <sup>ー</sup> ルト <sup>2</sup>                    | MANIFOLD, 2         |    |
| 1-111-2 | S39116100 | 2    | ハ <sup>ル</sup> フ <sup>VQZ2151S-5</sup>              | VALVE, VQZ2151S-5   |    |
| 1-111-3 | S59368000 | 1    | ツキ <sup>テ</sup> KQ2H0801S                           | JOINT, KQ2H0801S    |    |
| 1-111-4 | 140682001 | 1    | サイレンサ <sup>ン</sup>                                  | SILENCER            |    |
| 1-111-5 | 153274001 | 2    | 1/8 <sup>ト</sup> メセ <sup>ン</sup>                    | CAP, 1/8            |    |
| 1-112   | 018503036 | 2    | アホ <sup>ホ</sup> ルト5X30                              | BOLT, SOCKET M5X30  |    |
| 1-113   | 028050246 | 2    | ハ <sup>ネ</sup> サ <sup>カ</sup> ネ2-5                  | WASHER, SPRING 2-5  |    |
| 1-117   | S54602000 | 2    | エアホ <sup>ー</sup> ス0604U035B                         | AIR TUBE, 060U035B  |    |
| 1-118   | S59387000 | 2    | エアホ <sup>ー</sup> ス0604U050B                         | AIR TUBE, 060U050B  |    |
| 1-130   | S04557000 | 2    | ハ <sup>ン</sup> タイPLT1M                              | BAND, PLT1M         |    |
| 12      | S52991000 | 1    | ハ <sup>ー</sup> スタツカ <sup>ー</sup> ハ <sup>ー</sup> ネスL | STACKER HARNESS, L  |    |
| 13      | S58693000 | 1    | エアホ <sup>ー</sup> ス0806U175B                         | AIR TUBE, 0806U175B |    |
| 100     | S39821000 | 1    | ユ <sup>ー</sup> ト <sup>ク</sup> ランフ <sup>7</sup> 19P7 | CORD CLAMP, 19P7    |    |
| 101     | S04557000 | 2    | ハ <sup>ン</sup> タイPLT1M                              | BAND, PLT1M         |    |

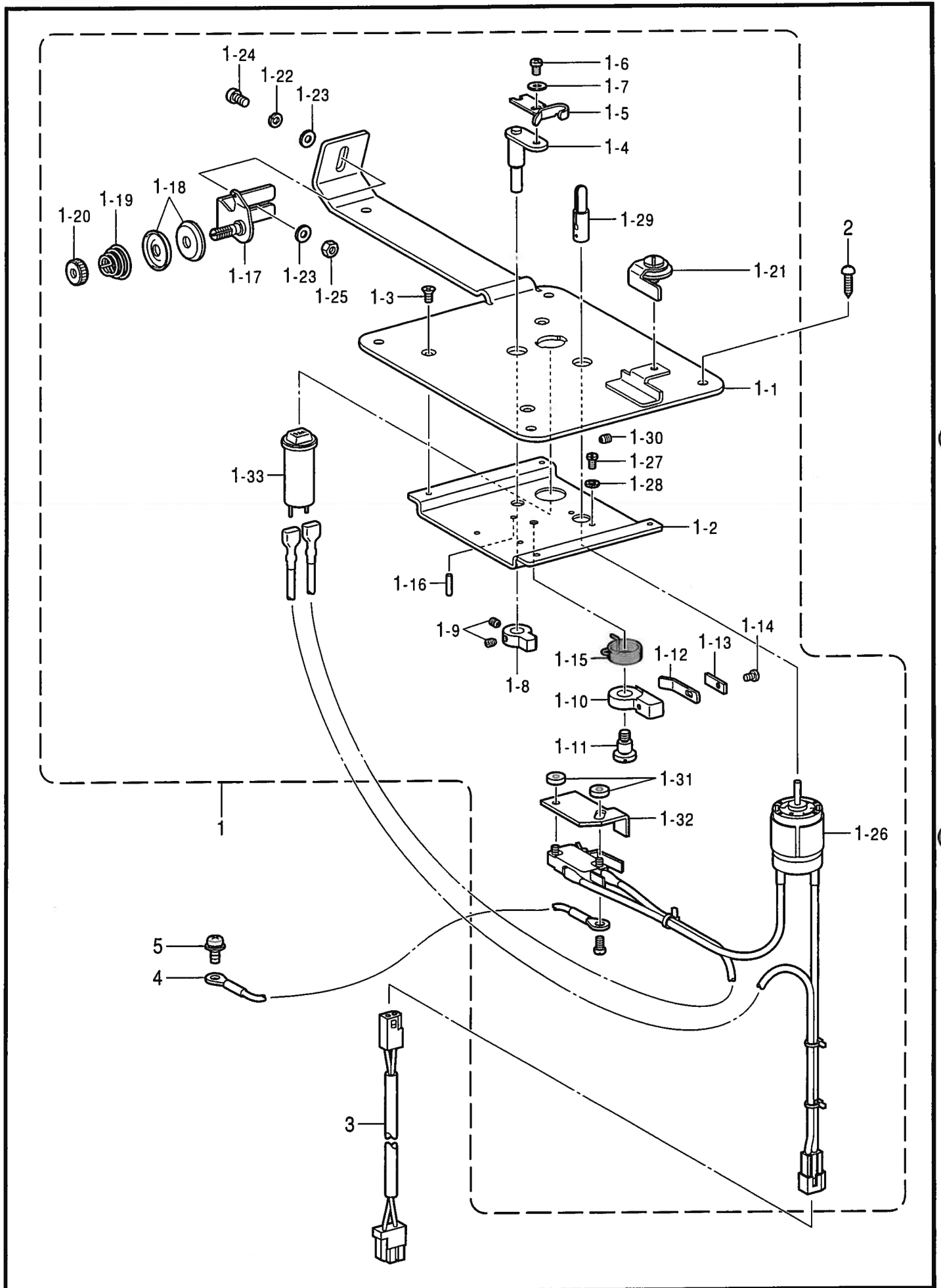

## S.糸巻関係 / Bobbin winder mechanism

| REF.NO | CODE      | Q'TY | ヒンメイ           | NAME OF PARTS                 | RM |
|--------|-----------|------|----------------|-------------------------------|----|
| 1      | 152651401 | 1    | イトマキソウチクミ      | BOBBIN WINDER ASSY            |    |
| 1-1    | 152356301 | 1    | イトマキトタイ        | BOBBIN WINDER BASE            |    |
| 1-2    | S39902001 | 1    | イトマキモータシジイタ    | SUPPORT PLATE, ;B-W/MOTOR     |    |
| 1-3    | 004300513 | 4    | +サヲコ3X5        | SCREW, FLAT M3X5              |    |
| 1-4    | 154024001 | 1    | ホビンオサヒ         | BOBBIN PRESSER                |    |
| 1-5    | 152645001 | 1    | ホビンオサヒイタ       | BOBBIN HOLDER                 |    |
| 1-6    | 062300616 | 1    | ナハコM3X6        | SCREW, PAN M3X6               |    |
| 1-7    | 025030233 | 1    | ヒラサガネチユウ3      | WASHER, PLAIN M 3             |    |
| 1-8    | 154092001 | 1    | イトマキツメタツキ      | BOBBIN WINDER CLAW            |    |
| 1-9    | 014680422 | 2    | アナトメネジ 4.37クホミ | SET SCREW, SOCKET (CP) SM4.37 |    |
| 1-10   | 152361001 | 1    | イトマキレバー        | LEVER, ;B-WINDER              |    |
| 1-11   | 152362001 | 1    | イトマキタンネジ       | SHOULDER SCREW                |    |
| 1-12   | 111942001 | 1    | イタハネ           | SPRING, PLATE                 |    |
| 1-13   | 111943001 | 1    | イタハネサガネ        | WASHER                        |    |
| 1-14   | 060660512 | 1    | ハイント 318-40X5  | SCREW, BIND SM3.18-40X5       |    |
| 1-15   | 152363001 | 1    | ネジリハネ          | SPRING, TWIST A               |    |
| 1-16   | 047301042 | 1    | スプリングピン        | SPRING PIN                    |    |
| 1-17   | 145571101 | 1    | イトマキアンナイタイクミ   | GUIDE BRACKET ASSY, ;B-WINDER |    |
| 1-18   | 145446001 | 2    | イトチヨウシサ        | DISC, TENSION                 |    |
| 1-19   | 100401001 | 1    | イトチヨウシハネ       | TENSION SPRING                |    |
| 1-20   | 100136001 | 1    | イトチヨウシナツト      | NUT, TENSION                  |    |
| 1-21   | 146197001 | 1    | イトツカミクミ        | THREAD NIPPER ASSY            |    |
| 1-22   | 028040243 | 1    | ハネサガネ2-4       | WASHER, SPRING 2-4            |    |
| 1-23   | 025040233 | 2    | ヒラサガネチユウ4      | WASHER, PLAIN M 4             |    |
| 1-24   | 062401006 | 1    | ナハコ4X10        | SCREW, PAN M4X10              |    |
| 1-25   | 021400103 | 1    | ナツト1シユ4        | NUT, 1 M4                     |    |
| 1-26   | S39847001 | 1    | イトマキモータクミ      | MOTOR ASSY, ;B-WINDER         |    |
| 1-27   | S35032101 | 2    | シメネジ 2.6X5.5   | SCREW, M2.6X5.5               |    |
| 1-28   | 028260242 | 2    | ハネサガネ2-2.6     | WASHER, SPRING 2-2.6          |    |
| 1-29   | S39901001 | 1    | イトマキシク         | SHAFT, ;B-WINDER              |    |
| 1-30   | 014300332 | 2    | アナクホミ3X3       | SET SCREW, SOCKET (CP) M3X3   |    |
| 1-31   | 152364001 | 2    | カラ             | COLLAR                        |    |
| 1-32   | 158597001 | 1    | イトマキストツパー      | STOPPER, ;B-WINDER            |    |
| 1-33   | S16669000 | 1    | プロテクタ0.5A      | PROTECTOR, 0.5A               |    |
| 2      | 032311306 | 5    | +マルモクネジ 3.1X13 | WOOD SCREW, ROUND M3.1X13     |    |
| 3      | S52459000 | 1    | イトマキハーネス       | BOBBIN WINDER HARNESS         |    |
| 4      | S52460000 | 1    | ア-スセン110       | GROUND WIRE                   |    |
| 5      | 0A5400805 | 1    | +ナハサクミ4X8DB    | SCREW, PAN (S/P WASHER) M4X8  |    |

T. 空圧関係 / Air pressure mechanism

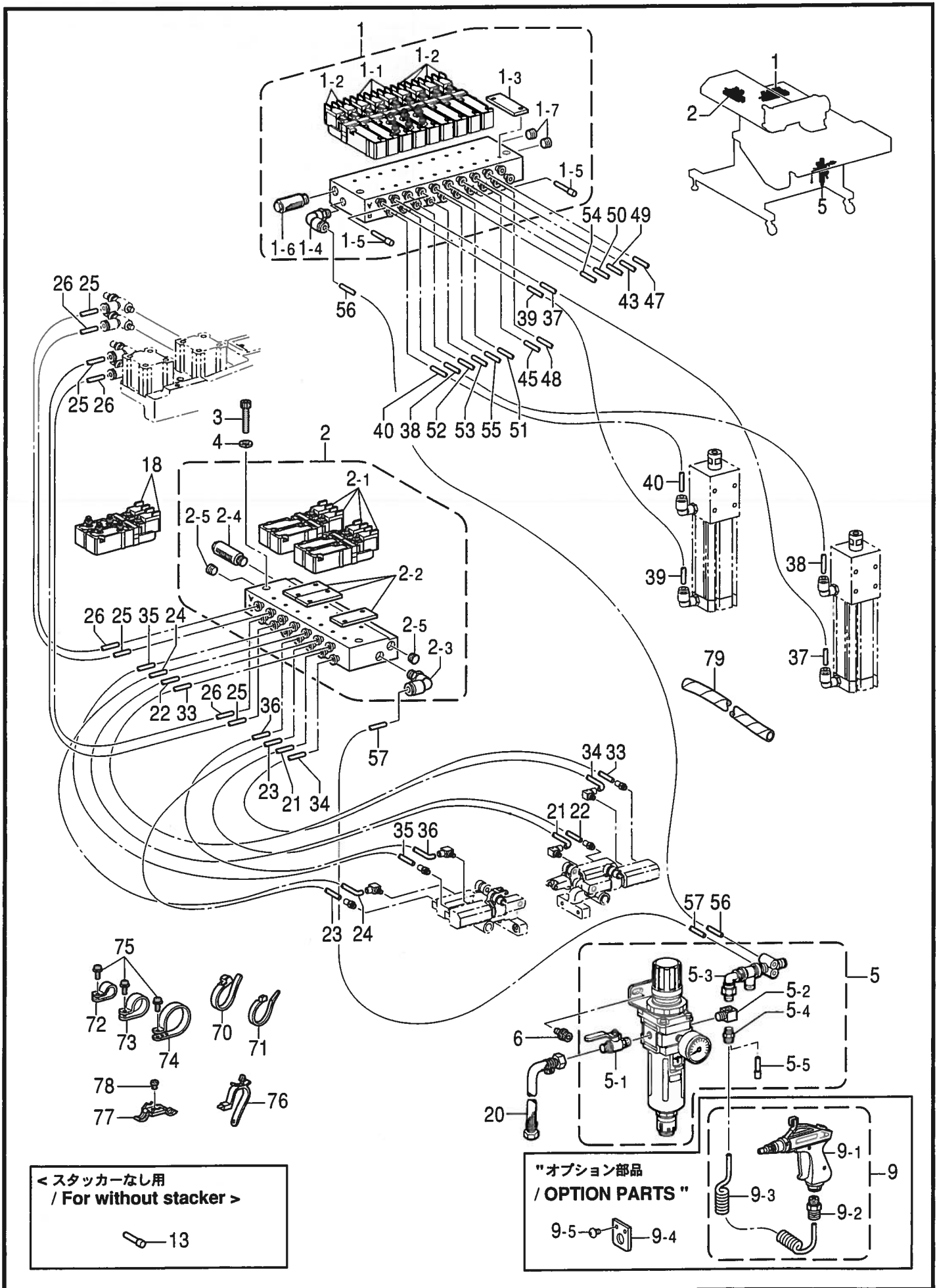

T.空圧関係 / Air pressure mechanism

| REF.NO | CODE      | Q'TY | ヒンメイ            | NAME OF PARTS                  | RM |
|--------|-----------|------|-----------------|--------------------------------|----|
| 1      | S55571001 | 1    | バルブユニット10       | VALVE UNIT, 10                 |    |
| 1-1    | S39116100 | 3    | バルブVQZ2151S-5   | VALVE, VQZ2151S-5              |    |
| 1-2    | S39115100 | 6    | バルブVQZ2151-5    | VALVE, VQZ2151-5               |    |
| 1-3    | S53982000 | 1    | ブランキングプレートクミ    | BLANKING PLATE ASSY            |    |
| 1-4    | S53981000 | 1    | エルボ KQ2L0601S   | ELBOW, KQWL0601S               |    |
| 1-5    | S53983000 | 3    | プラグ4            | PLUG, 4                        |    |
| 1-6    | 140682001 | 1    | サイレンザン          | SILENCER                       |    |
| 1-7    | 153274001 | 2    | 1/8メセン          | CAP, 1/8                       |    |
| 2      | S55300101 | 1    | バルブユニット7        | VALVE UNIT, 7                  |    |
| 2-1    | S39115100 | 4    | バルブVQZ2151-5    | VALVE, VQZ2151-5               |    |
| 2-2    | S53982000 | 3    | ブランキングプレートクミ    | BLANKING PLATE ASSY            |    |
| 2-3    | S59372000 | 1    | エルボ KJL0601S    | ELBOW, KJL0601S                |    |
| 2-4    | 140682001 | 1    | サイレンザン          | SILENCER                       |    |
| 2-5    | 153274001 | 2    | 1/8メセン          | CAP, 1/8                       |    |
| 3      | 018503036 | 2    | アナボルト5X30       | BOLT, SOCKET M5X30             |    |
| 4      | 028050246 | 2    | ハネサカネ2-5        | WASHER, SPRING 2-5             |    |
| 5      | S56868000 | 1    | フィルタレギュレータークミ   | FILTER REGULATOR ASSY          |    |
| 5-1    | S09231000 | 1    | ボールバルブ1/4       | BALL VALVE, 1/4                |    |
| 5-2    | 153252000 | 1    | PTチース           | PT-JOINT                       |    |
| 5-3    | S56869000 | 1    | ハイカンモジュールクミ     | PLUMBING MODULE ASSY           |    |
| 5-4    | S59219000 | 1    | ハーフユニオン08-PT1/4 | HALF UNION, ;KQ2H08-02S        |    |
| 5-5    | S53985000 | 1    | プラグ8            | PLUG, 8                        |    |
| 6      | S55484001 | 2    | アナボルトソケット5X10   | SCREW, SOCKET (S/P W) M5X10    |    |
|        |           |      | <オプション部品>       | <OPTION PARTS>                 |    |
| 9      | S59217000 | 1    | エアガンクミ          | AIR GUN ASSY                   |    |
| 9-1    | S59218000 | 1    | エアガン            | AIR GUN                        |    |
| 9-2    | S59219000 | 1    | ハーフユニオン08-PT1/4 | HALF UNION, ;KQ2H08-02S        |    |
| 9-3    | S59220000 | 1    | ホリウレタンコイルチューブ   | AIR TUBE, COIL ;TCU0805B       |    |
| 9-4    | S12506000 | 1    | エアガンフック         | AIR GUN HOOK                   |    |
| 9-5    | 008400604 | 2    | +トラスコ4X6        | SCREW, TRUSS M4X6              |    |
|        |           |      | <スタッカーなし用>      | <For without stacker>          |    |
| 13     | S53985000 | 1    | プラグ8            | PLUG, 8                        |    |
|        |           |      | <オプション部品/フラップ用> | <OPTION PARTS/ For flap clamp> |    |
| 18     | S39116100 | 2    | バルブVQZ2151S-5   | VALVE, VQZ2151S-5              |    |
| 20     | 149796001 | 1    | ゴムホースカゲツキ       | AIR HOSE, W/CONNECTOR          |    |
| 21     | S53960000 | 1    | エアホース0425U045B1 | AIR TUBE, 0425U045B1           |    |
| 22     | S53961000 | 1    | エアホース0425U045B2 | AIR TUBE, 0425U045B2           |    |
| 23     | S53962000 | 1    | エアホース0425U025B  | AIR TUBE, 0425U025B            |    |
| 24     | S53963000 | 1    | エアホース0425U026B  | AIR TUBE, 0425U026B            |    |
| 25     | S58039000 | 2    | エアホース0425S024B  | AIR TUBE, 0425S024B            |    |
| 26     | S58040000 | 2    | エアホース0425S028B  | AIR TUBE, 0425S028B            |    |
|        |           |      | <オプション部品/フラップ用> | <OPTION PARTS/ For flap clamp> |    |
| 33     | S53958000 | 1    | エアホース0425U050B1 | AIR TUBE, 0425U050B1           |    |
| 34     | S53959000 | 1    | エアホース0425U050B2 | AIR TUBE, 0425U050B2           |    |
| 35     | S53964000 | 1    | エアホース0425U032B  | AIR TUBE, 0425U032B            |    |
| 36     | S53965000 | 1    | エアホース0425U030B  | AIR TUBE, 0425U030B            |    |
| 37     | S58037000 | 1    | エアホース0604U128B  | AIR TUBE, 0604U128B            |    |
| 38     | S58038000 | 1    | エアホース0604U146B  | AIR TUBE, 0604U146B            |    |
| 39     | S58035000 | 1    | エアホース0604U091B  | AIR TUBE, 0604U091B            |    |
| 40     | S58036000 | 1    | エアホース0604U103B  | AIR TUBE, 0604U103B            |    |
| 43     | S53952000 | 1    | エアホース0425S115B  | AIR TUBE, 0425S115B            |    |
| 45     | S58034000 | 1    | エアホース0425S123B  | AIR TUBE, 0425S123B            |    |
| 47     | S55009000 | 1    | エアホース0425S066B  | AIR TUBE, 0425S066B            |    |
| 48     | S55010000 | 1    | エアホース0425S070B  | AIR TUBE, 0425S070B            |    |
| 49     | S53951000 | 1    | エアホース0425S107B  | AIR TUBE, 0425S107B            |    |

T. 空圧関係 / Air pressure mechanism

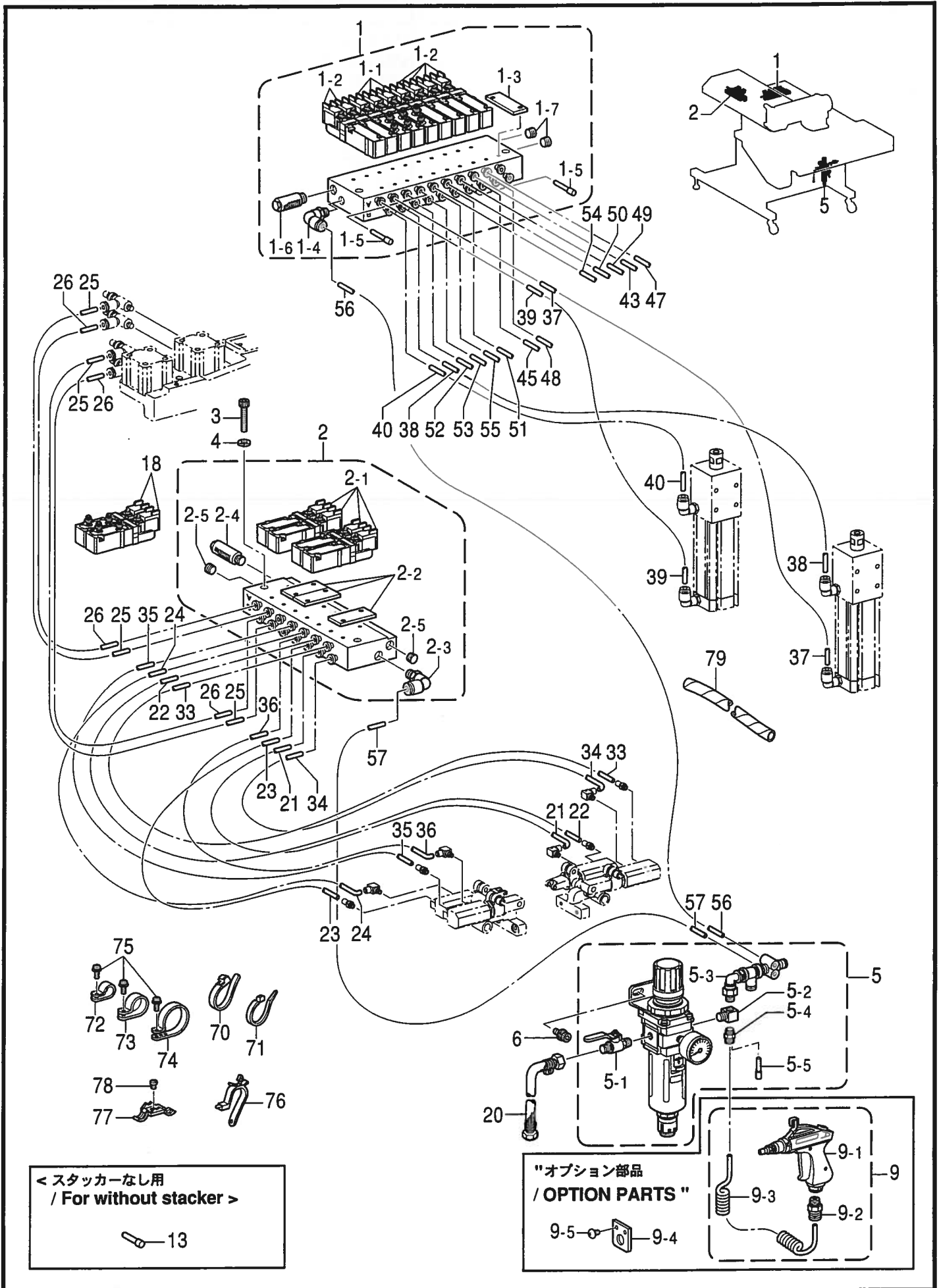



## T.空圧関係 / Air pressure mechanism

| REF.NO | CODE      | Q'TY | ヒンメイ           | NAME OF PARTS                 | RM |
|--------|-----------|------|----------------|-------------------------------|----|
| 50     | S55013000 | 1    | エアホ-ス0425S088B | AIR TUBE, 0424S088B           |    |
| 51     | S53954000 | 1    | エアホ-ス0425S110B | AIR TUBE, 0254S110B           |    |
| 52     | S53952000 | 1    | エアホ-ス0425S115B | AIR TUBE, 0425S115B           |    |
| 53     | S54614000 | 1    | エアホ-ス0425S122B | AIR TUBE, 0425S122B           |    |
| 54     | S54615000 | 1    | エアホ-ス0425S125B | AIR TUBE, 0425S125B           |    |
| 55     | S54615000 | 1    | エアホ-ス0425S125B | AIR TUBE, 0425S125B           |    |
| 56     | S53973000 | 1    | エアホ-ス0604S051B | AIR TUBE, 0604S051B           |    |
| 57     | S54104000 | 1    | エアホ-ス0604U190B | AIR TUBE, 0604U190B           |    |
| 70     | S52973000 | 3    | リヒ-トタイRF100    | REPEATE CABLE TIE, RF100      |    |
| 71     | S04557000 | 1    | バンタイPLT1M      | BAND, PLT1M                   |    |
| 72     | 149287000 | 1    | ナイロンクランプ       | CORD HOLDER, 7N               |    |
| 73     | 552908000 | 1    | コードホルダ#14      | CORD HOLDER, 14N              |    |
| 74     | 158581000 | 1    | コードホルダ#24      | CORD HOLDER, 24N              |    |
| 75     | 0A5401005 | 3    | ナハサクミ4X10DB    | SCREW, PAN (S/P WASHER) M4X10 |    |
| 76     | S39821000 | 2    | コードクランプ19P7    | CORD CLAMP, 19P7              |    |
| 77     | S10859001 | 3    | クランプ           | CLAMP                         |    |
| 78     | 002300603 | 3    | ナハコ3X6         | SCREW, PAN M3X6               |    |
| 79     | S55303000 | 1    | スパイラル80S       | SPIRAL, 80S                   |    |

U . 電装品関係 / Power supply equipment mechanism

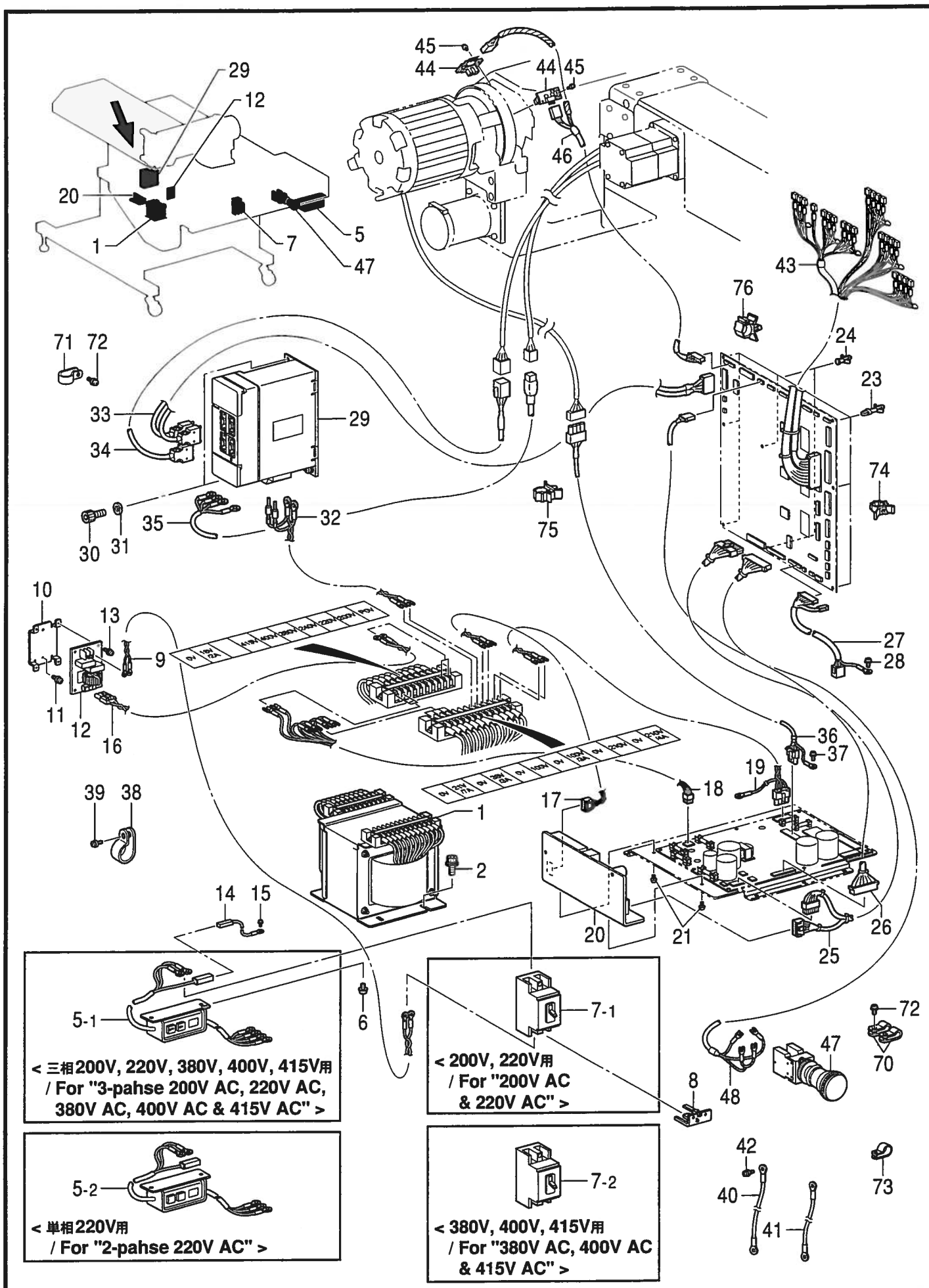

5-1  
 < 三相200V, 220V, 380V, 400V, 415V用  
 / For "3-phase 200V AC, 220V AC,  
 380V AC, 400V AC & 415V AC" >

5-2  
 < 单相220V用  
 / For "2-phase 220V AC" >

7-1  
 < 200V, 220V用  
 / For "200V AC  
 & 220V AC" >

7-2  
 < 380V, 400V, 415V用  
 / For "380V AC, 400V AC  
 & 415V AC" >

U.電装品関係 / Power supply equipment mechanism

| REF.NO | CODE      | Q'TY | ヒンメイ   | NAME OF PARTS   | RM |
|--------|-----------|------|--|---|----|
| 1      | S52760000 | 1    | トランス   | TRANSFORMER, 1.4KVA   |    |
| 2      | S55476001 | 4    | アナホルトサクミ6X12                                       | BOLT, SOCKET(S/P WASHER)M6X12   |    |
| 5-1    | S52472001 | 1    | <3相200V, 220V,<br>380V, 400V, 415V用><br>デンゲンSW3Pクミ | <For "3-phase 200V AC, 220V AC,<br>380V AC, 400V AC & 415V AC"><br>POWER SUPPLY SWITCH ASSY, 3P |    |
| 5-2    | S52968001 | 1    | <单相220V用><br>デンゲンSW2Pクミ                            | <For "Single phase 220V AC"><br>POWER SUPPLY SWITCH ASSY, 2P                                    |    |
| 6      | 0A5400805 | 2    | ナハサクミ4X8DB   | SCREW, PAN (S/P WASHER) M4X8  |    |
| 7-1    | S47900000 | 1    | <200V, 220V用><br>ブレーカ-M10A                         | <For "200V AC & 220V AC"><br>BREAKER, M ;10A  |    |
| 7-2    | S52437000 | 1    | <380V, 400V, 415V用><br>ブレーカ-M5A                    | <For "380V AC, 400V AC & 415V AC"><br>BRAEKER, M ;5A  |    |
| 8      | S52727000 | 1    | タンシカハ-   | TERMINAL COVER  |    |
| 9      | S52475000 | 1    | ブレーカ-NFハーネス  | HARNESS, BR-NF  |    |
| 10     | S40620000 | 1    | キハントリツケイタ  | SETTING PLATE, ;PCB   |    |
| 11     | 0A5400805 | 2    | ナハサクミ4X8DB   | SCREW, PAN (S/P WASHER) M4X8  |    |
| 12     | S40616001 | 1    | ノイズフィルタEMCクミ                                       | NOISE FILTER ASSY, EMC  |    |
| 13     | 0A5400805 | 4    | ナハサクミ4X8DB   | SCREW, PAN (S/P WASHER) M4X8  |    |
| 14     | S52478000 | 1    | ア-センPE   | GROUND WIRE, PE   |    |
| 15     | 0A5400805 | 1    | ナハサクミ4X8DB   | SCREW, PAN (S/P WASHER) M4X8  |    |
| 16     | S52476000 | 1    | NF-Tハーネス   | HARNESS, NF-T   |    |
| 17     | S52439000 | 1    | AVRハーネス  | HARNESS, T-AVR  |    |
| 18     | S52440000 | 1    | T-PキハントハーネスA                                       | PCB HARNESS, A ;T-P/PCB   |    |
| 19     | S52441000 | 1    | T-PキハントハーネスB                                       | PCB HARNESS, B ;T-P/PCB   |    |
| 20     | S46738000 | 1    | スイッチングデンゲン   | POWER SUPPLY, SWITCHING   |    |
| 21     | 0A5300805 | 2    | ナハサクミ3X8DB   | SCREW, PAN (S/P WASHER) M3X8  |    |
| 23     | S00554000 | 7    | サホ-ト6NS  | SUPPORT, 6NS  |    |
| 24     | S38111000 | 2    | サホ-ト6S   | SUPPORT, 6S   |    |
| 25     | S52443000 | 1    | メインパワーハーネス   | POWER SUPPLY HARNESS, P-M/PCB   |    |
| 26     | S52444000 | 1    | インバータハーネス  | INVERTER HARNESS, P-M/PCB   |    |
| 27     | S52457000 | 1    | フットSWハーネス  | FOOT SW HARNESS, M/PCB-BOX  |    |
| 28     | 0A5400805 | 1    | ナハサクミ4X8DB   | SCREW, PAN (S/P WASHER) M4X8  |    |
| 29     | S52952001 | 1    | サホアンフ62Xクミ   | SERVO AMPLIFIER ASSY, 62X   |    |
| 30     | 018061436 | 2    | アナホルト6X14  | BOLT, SOCKET M6X14  |    |
| 31     | 028060246 | 2    | ハネサカネ2-6   | WASHER, SPRING 2-6  |    |
| 32     | S52442000 | 1    | サホパワーハーネス  | SERVO POWER HARNESS, T-AMP  |    |
| 33     | S52445000 | 1    | サホハーネス   | SERVO HARNESS, M/PCB-AMP  |    |
| 34     | S52447000 | 1    | エンコダハーネス   | ENCODER HARNESS, AMP-MOT  |    |
| 35     | S52448000 | 1    | モータパワーハーネス   | M/POWER HARNESS, AMP-MOT  |    |
| 36     | S52446000 | 1    | モシモータパワーハーネス                                       | MOTOR POWER HARNESS, P/PCB-MOT  |    |
| 37     | 0A5401005 | 1    | ナハサクミ4X10DB  | SCREW, PAN (S/P WASHER) M4X10   |    |
| 38     | 552908000 | 1    | コードホルダ#14  | CORD HOLDER, 14N  |    |
| 39     | 0A5401005 | 1    | ナハサクミ4X10DB  | SCREW, PAN (S/P WASHER) M4X10   |    |
| 40     | S52732000 | 1    | ア-セン1600   | GROUND WIRE, L=1600   |    |
| 41     | S52733000 | 2    | ア-セン1050   | GROUND WIRE, L=1050   |    |
| 42     | 0A5400805 | 4    | ナハサクミ4X8DB   | SCREW, PAN (S/P WASHER) M4X8  |    |
| 43     | S52450000 | 1    | メインバルブハーネス   | MAIN VALVE HARNESS  |    |
| 44     | S12463001 | 2    | センサキハングミ1  | SENSOR PCB ASSY, 1  |    |
| 45     | 0A4300605 | 2    | ナハサクミ3X6DA   | SCREW, PAN (S/P WASHER) M3X6  |    |
| 46     | S52449000 | 1    | ミシンセンサハーネス   | M/SENSOR HARNESS, CYC-M/PCB   |    |
| 47     | S52744000 | 1    | スイッチA22E-M-11                                      | SWITCH, A22E-M-11   |    |
| 48     | S52461000 | 1    | EMSWハーネス   | EM/SW HARNESS, EM/SW-M/PCB  |    |
| 70     | S00480000 | 2    | コードホルダ#5   | CORD HOLDER, 5N   |    |
| 71     | 552907000 | 1    | コードホルダ#10  | CORD HOLDER, 10N  |    |
| 72     | 0A5401005 | 3    | ナハサクミ4X10DB  | SCREW, PAN (S/P WASHER) M4X10   |    |

U . 電装品関係 / Power supply equipment mechanism

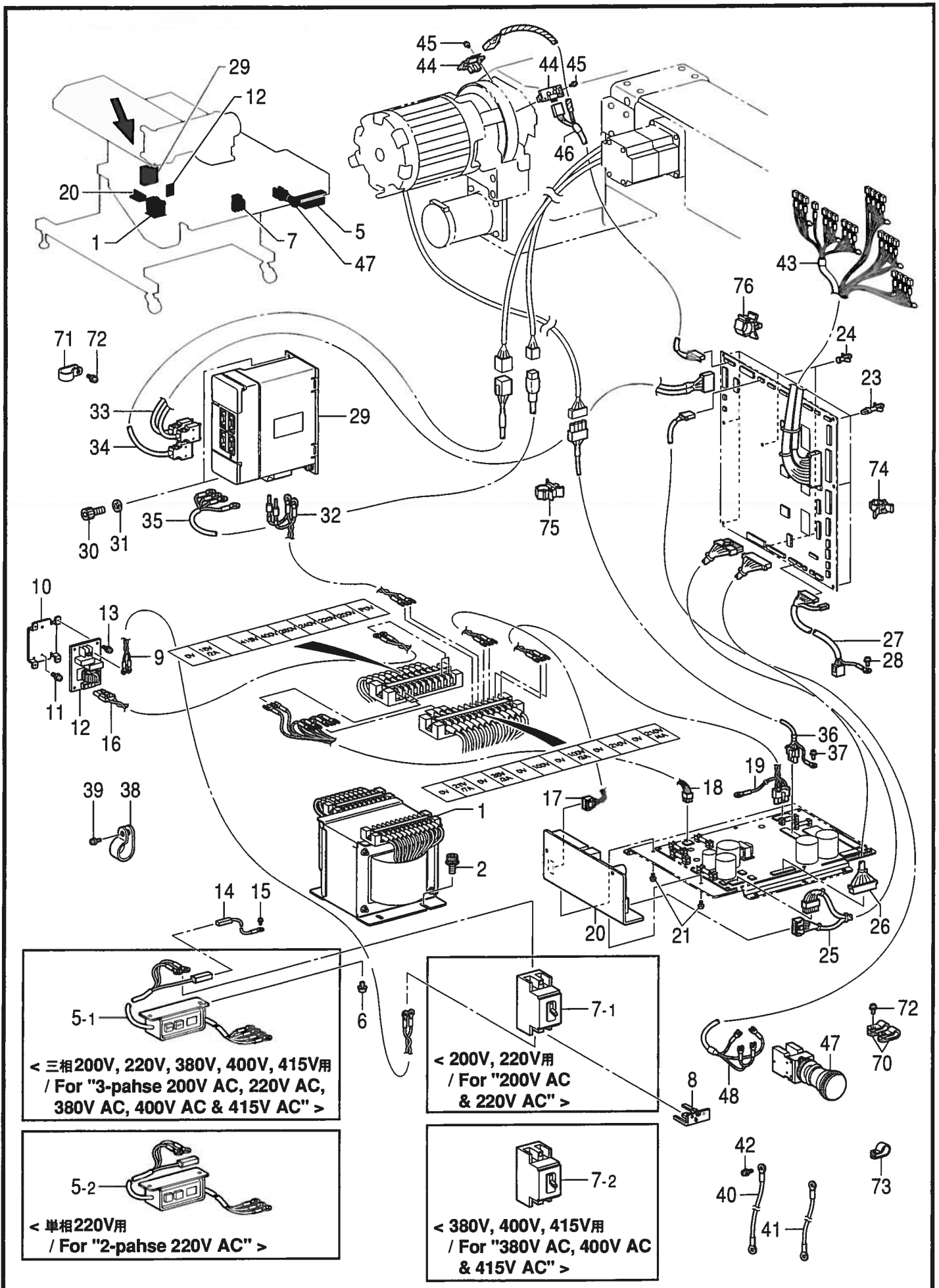

5-1  
 < 三相200V, 220V, 380V, 400V, 415V用  
 / For "3-pahse 200V AC, 220V AC,  
 380V AC, 400V AC & 415V AC" >

5-2  
 < 单相220V用  
 / For "2-pahse 220V AC" >

7-1  
 < 200V, 220V用  
 / For "200V AC  
 & 220V AC" >

7-2  
 < 380V, 400V, 415V用  
 / For "380V AC, 400V AC  
 & 415V AC" >

U.電装品関係 / Power supply equipment mechanism

| REF.NO | CODE      | Q'TY | ヒンメイ                     | NAME OF PARTS    | RM |
|--------|-----------|------|--------------------------|------------------|----|
| 73     | 149287000 | 1    | ナイロンクランプ                 | CORD HOLDER, 7N  |    |
| 74     | S09141000 | 6    | コートクランプ <sup>°</sup> 16L | CORD CLAMP, 16-L |    |
| 75     | S09142000 | 1    | コートクランプ <sup>°</sup> 20L | CORD CLAMP, 20-L |    |
| 76     | S31760000 | 4    | CKSクランプ <sup>°</sup> 26L | CORD CLAMP, 26-L |    |

V1 . 布制御関係 / Cloth control system mechanism

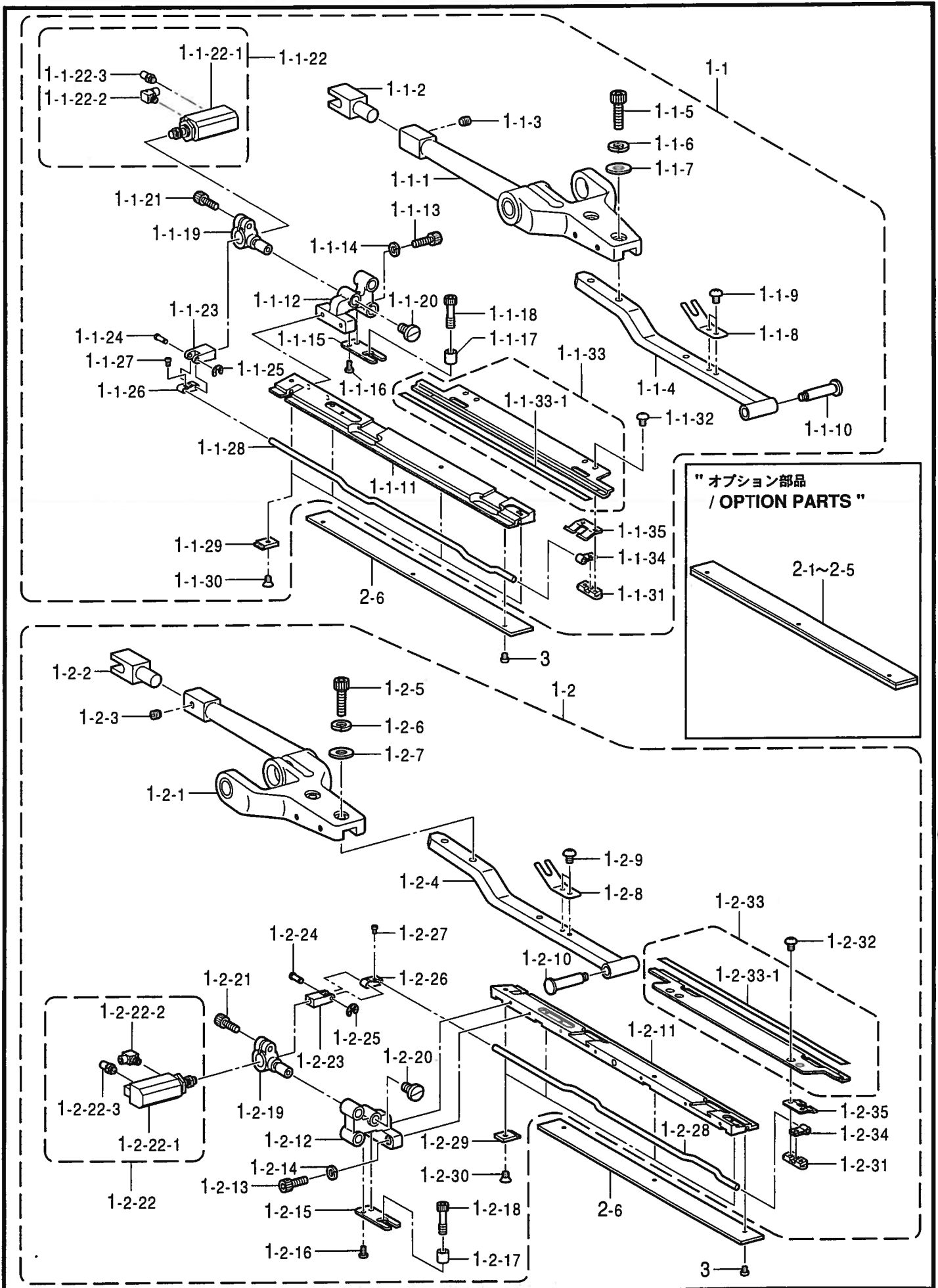

151-615-516

V1.布制御関係 / Cloth control system mechanism

| REF.NO   | CODE      | Q'TY | ヒンメイ          | NAME OF PARTS               | RM |
|----------|-----------|------|---------------|-----------------------------|----|
| 1        | S53531000 | 1    | オオサI220クミ     | CARRIAGE FEED ASSY, 220     |    |
| 1-1      | S53532001 | 1    | オオサI220Rクミ    | CARRIAGE FEED ASSY, R-220   |    |
| 1-1-1    | S53558001 | 1    | オオサIレハ-Rクミ    | CARRIAGE FEED LEVER ASSY, R |    |
| 1-1-2    | S53564001 | 1    | オサエウテツキテ      | COUPLING                    |    |
| 1-1-3    | 012060636 | 1    | アナヒラ6X6       | SET SCREW, SOCKET (FT) M6X6 |    |
| 1-1-4    | S53533001 | 1    | オオサIトリツケレハ-R  | SETTING LEVER, R            |    |
| 1-1-5    | 018062036 | 2    | アナホルト6X20     | BOLT, SOCKET M6X20          |    |
| 1-1-6    | 028060246 | 2    | ハネサガネ2-6      | WASHER, SPRING 2-6          |    |
| 1-1-7    | 025060236 | 2    | ヒラサガネチユウ6     | WASHER, PLAIN M 6           |    |
| 1-1-8    | S53534100 | 1    | オオサIハネ        | CARRIAGE FEED SPRING        |    |
| 1-1-9    | 008400604 | 2    | +トラスコ4X6      | SCREW, TRUSS M4X6           |    |
| 1-1-10   | S53535001 | 1    | ダンネジ6.35      | SHOULDER SCREW, SM6.35      |    |
| 1-1-11   | S53536001 | 1    | オオサIR         | CARRIAGE FEED, R            |    |
| 1-1-12   | S53537001 | 1    | ジグダイ          | SUPPORT BRACKET             |    |
| 1-1-13   | 018501236 | 2    | アナホルト5X12     | BOLT, SOCKET M5X12          |    |
| 1-1-14   | 028050246 | 2    | ハネサガネ2-5      | WASHER, SPRING 2-5          |    |
| 1-1-15   | S53538101 | 1    | キノウイタ         | STOPPER & POSITIONING PLATE |    |
| 1-1-16   | 060400812 | 2    | ハインドM4X8      | SCREW, BIND M4X8            |    |
| 1-1-17   | S53539001 | 1    | カラ-           | COLLAR                      |    |
| 1-1-18   | S58204001 | 1    | カラ-オサIネジ      | SCREW, COLLAR PRESS         |    |
| 1-1-19   | S53540001 | 1    | シリンダ-タイ       | CYLINDER BASE               |    |
| 1-1-20   | 115503001 | 1    | シメネジ4.37      | SCREW, SM4.37               |    |
| 1-1-21   | 018501036 | 1    | アナホルト5X10     | BOLT, SOCKET M5X10          |    |
| 1-1-22   | S53541000 | 1    | シリンダ-クミ       | CYLINDER ASSY               |    |
| 1-1-22-1 | S14666000 | 1    | シリンダ16X20     | CYLINDER, 16X20             |    |
| 1-1-22-2 | S12150000 | 1    | ホ-スエルホM-5HL-4 | TUBE ELBOW, M-5HL-4         |    |
| 1-1-22-3 | S11433000 | 1    | ホ-スツブル4M5     | HOSE NIPPLE, 4M5            |    |
| 1-1-23   | S53543001 | 1    | リンクレハ-ツキテ     | JOINT                       |    |
| 1-1-24   | S53544001 | 1    | ピン002         | PIN, 002                    |    |
| 1-1-25   | 048025342 | 1    | トメE2.5        | RETAINING RING, E2.5        |    |
| 1-1-26   | S53545001 | 1    | リンクレハ-        | LINK LEVER                  |    |
| 1-1-27   | 002300603 | 1    | +ナベコ3X6       | SCREW, PAN M3X6             |    |
| 1-1-28   | S53546001 | 1    | オリコミイタリンクシク   | LINK SHAFT                  |    |
| 1-1-29   | S53547001 | 4    | リンクオサエイタ      | HOLDER PLATE                |    |
| 1-1-30   | S31258001 | 4    | +サラコ4X6       | SCREW, FLAT M4X6            |    |
| 1-1-31   | S53548000 | 2    | ハネオサエイタクミ     | SPRING HOLDER PLATE ASSY    |    |
| 1-1-32   | 008300604 | 4    | +トラスコ3X6      | SCREW, TRUSS M3X6           |    |
| 1-1-33   | S55454001 | 1    | オリコミイタRクミ     | FOLDING PLATE ASSY, R       |    |
| 1-1-33-1 | S57533000 | 1    | ハンシヤシート       | REFLECTING SHEET            |    |
| 1-1-34   | S53552000 | 2    | レンケツイタハネ      | SPRING, PLATE               |    |
| 1-1-35   | S53553000 | 2    | リンクオサエハネ      | SPRING, PLATE               |    |
| 1-2      | S53554001 | 1    | オオサI220Lクミ    | CARRIAGE FEED ASSY, L-220   |    |
| 1-2-1    | S53562001 | 1    | オオサIレハ-Lクミ    | CARRIAGE FEED LEVER ASSY, L |    |
| 1-2-2    | S53564001 | 1    | オサエウテツキテ      | COUPLING                    |    |
| 1-2-3    | 012060636 | 1    | アナヒラ6X6       | SET SCREW, SOCKET (FT) M6X6 |    |
| 1-2-4    | S53555001 | 1    | オオサIトリツケレハ-L  | SETTING LEVER, L            |    |
| 1-2-5    | 018062036 | 2    | アナホルト6X20     | BOLT, SOCKET M6X20          |    |
| 1-2-6    | 028060246 | 2    | ハネサガネ2-6      | WASHER, SPRING 2-6          |    |
| 1-2-7    | 025060236 | 2    | ヒラサガネチユウ6     | WASHER, PLAIN M 6           |    |
| 1-2-8    | S53534100 | 1    | オオサIハネ        | CARRIAGE FEED SPRING        |    |
| 1-2-9    | 008400604 | 2    | +トラスコ4X6      | SCREW, TRUSS M4X6           |    |
| 1-2-10   | S53535001 | 1    | ダンネジ6.35      | SHOULDER SCREW, SM6.35      |    |
| 1-2-11   | S53556001 | 1    | オオサIL         | CARRIAGE FEED, L            |    |
| 1-2-12   | S53537001 | 1    | ジグダイ          | SUPPORT BRACKET             |    |
| 1-2-13   | 018501236 | 2    | アナホルト5X12     | BOLT, SOCKET M5X12          |    |
| 1-2-14   | 028050246 | 2    | ハネサガネ2-5      | WASHER, SPRING 2-5          |    |
| 1-2-15   | S53538101 | 1    | キノウイタ         | STOPPER & POSITIONING PLATE |    |
| 1-2-16   | 060400812 | 2    | ハインドM4X8      | SCREW, BIND M4X8            |    |
| 1-2-17   | S53539001 | 1    | カラ-           | COLLAR                      |    |
| 1-2-18   | S58204001 | 1    | カラ-オサIネジ      | SCREW, COLLAR PRESS         |    |
| 1-2-19   | S53540001 | 1    | シリンダ-タイ       | CYLINDER BASE               |    |

V1 . 布制御関係 / Cloth control system mechanism

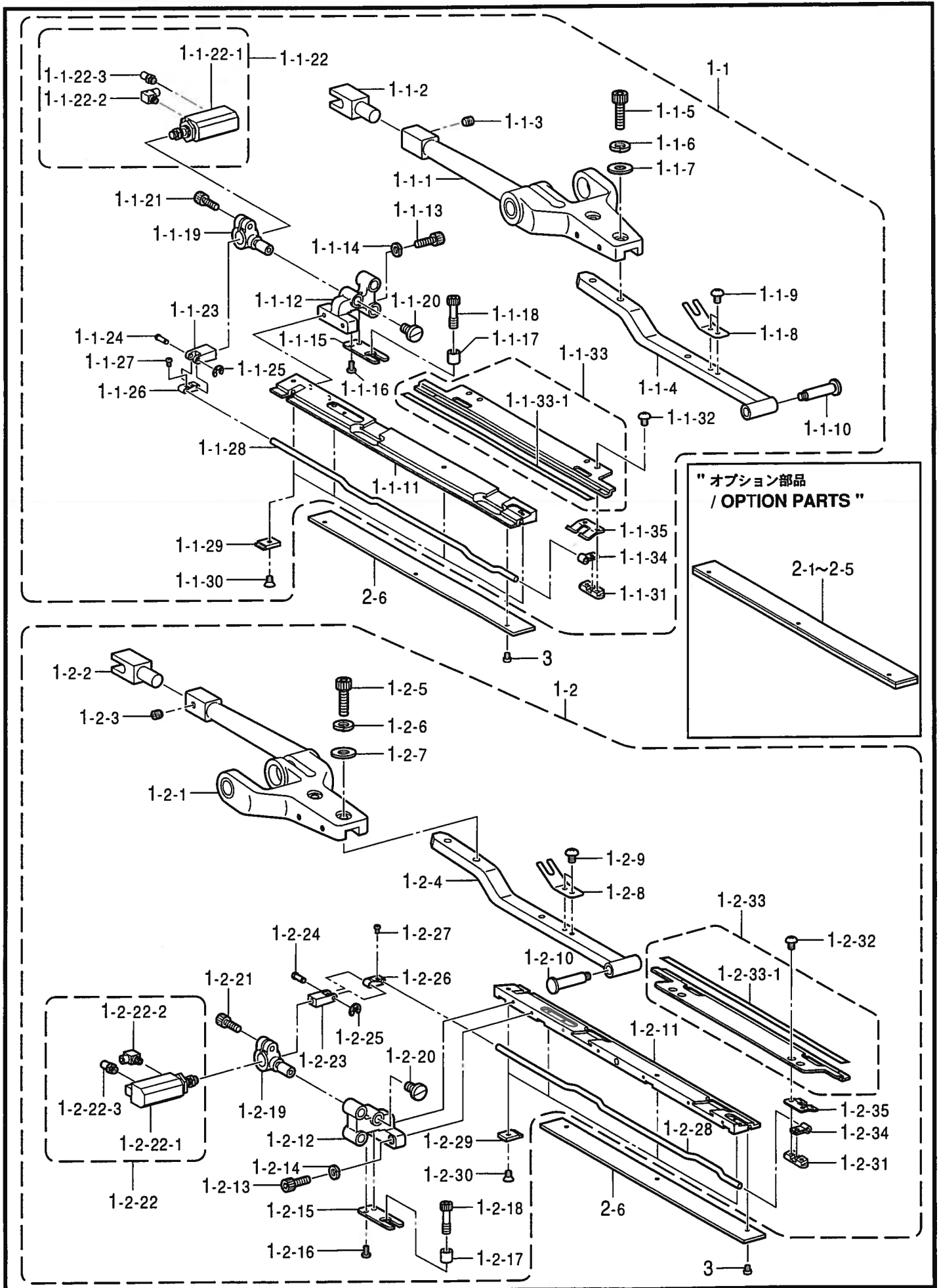

151-615-516



V1.布制御関係 / Cloth control system mechanism

| REF.NO   | CODE      | Q'TY | ヒンメイ           | NAME OF PARTS                  | RM |
|----------|-----------|------|----------------|--------------------------------|----|
| 1-2-20   | 115503001 | 1    | シメネジ 4.37      | SCREW, SM4.37                  |    |
| 1-2-21   | 018501036 | 1    | アナボルト5X10      | BOLT, SOCKET M5X10             |    |
| 1-2-22   | S53541000 | 1    | シリンダークミ        | CYLINDER ASSY                  |    |
| 1-2-22-1 | S14666000 | 1    | シリンダ 16X20     | CYLINDER, 16X20                |    |
| 1-2-22-2 | S12150000 | 1    | ホースエルボ M-5HL-4 | TUBE ELBOW, M-5HL-4            |    |
| 1-2-22-3 | S11433000 | 1    | ホースニツブ 4M5     | HOSE NIPPLE, 4M5               |    |
| 1-2-23   | S53543001 | 1    | リンクレハ ツキテ      | JOINT                          |    |
| 1-2-24   | S53544001 | 1    | ピン002          | PIN, 002                       |    |
| 1-2-25   | 048025342 | 1    | トメワE2.5        | RETAINING RING, E2.5           |    |
| 1-2-26   | S53545001 | 1    | リンクレハ          | LINK LEVER                     |    |
| 1-2-27   | 002300603 | 1    | ナハコ3X6         | SCREW, PAN M3X6                |    |
| 1-2-28   | S53546001 | 1    | オリコミイタリンクシク    | LINK SHAFT                     |    |
| 1-2-29   | S53547001 | 4    | リンクオサイタ        | HOLDER PLATE                   |    |
| 1-2-30   | S31258001 | 4    | ナハラコ4X6        | SCREW, FLAT M4X6               |    |
| 1-2-31   | S53548000 | 2    | ハネオサイタクミ       | SPRING HOLDER PLATE ASSY       |    |
| 1-2-32   | 008300604 | 4    | トラスコ3X6        | SCREW, TRUSS M3X6              |    |
| 1-2-33   | S55455001 | 1    | オリコミイタLクミ      | FOLDING PLATE ASSY, L          |    |
| 1-2-33-1 | S57533000 | 1    | ハンギシート         | REFLECTING SHEET               |    |
| 1-2-34   | S53552000 | 2    | レンケツイタハネ       | SPRING, PLATE                  |    |
| 1-2-35   | S53553000 | 2    | リンクオサイハネ       | SPRING, PLATE                  |    |
|          |           |      | <オプション部品>      | <OPTION PARTS>                 |    |
| 2-1      | S56006000 | 2    | オオサイコムAクミ      | CARRIAGE FEED RUBBER ASSY, A   |    |
| 2-2      | S56007000 | 2    | オオサイコムBクミ      | CARRIAGE FEED RUBBER ASSY, B   |    |
| 2-3      | S56008000 | 2    | オオサイコム1.5クミ    | CARRIAGE FEED RUBBER ASSY, 1.5 |    |
| 2-4      | S56009000 | 2    | オオサイコム2クミ      | CARRIAGE FEED RUBBER ASSY, 2   |    |
| 2-5      | S56010000 | 2    | オオサイコム3クミ      | CARRIAGE FEED RUBBER ASSY3     |    |
| 2-6      | S58903000 | 2    | オオサイコムCクミ      | CARRIAGE FEED RUBBER ASSY, C   |    |
| 3        | S58900000 | 6    | セイミツネジM2       | SCREW, M2                      |    |

V2 . 布制御関係 (オプション部品) / Cloth control system mechanism (Option parts)

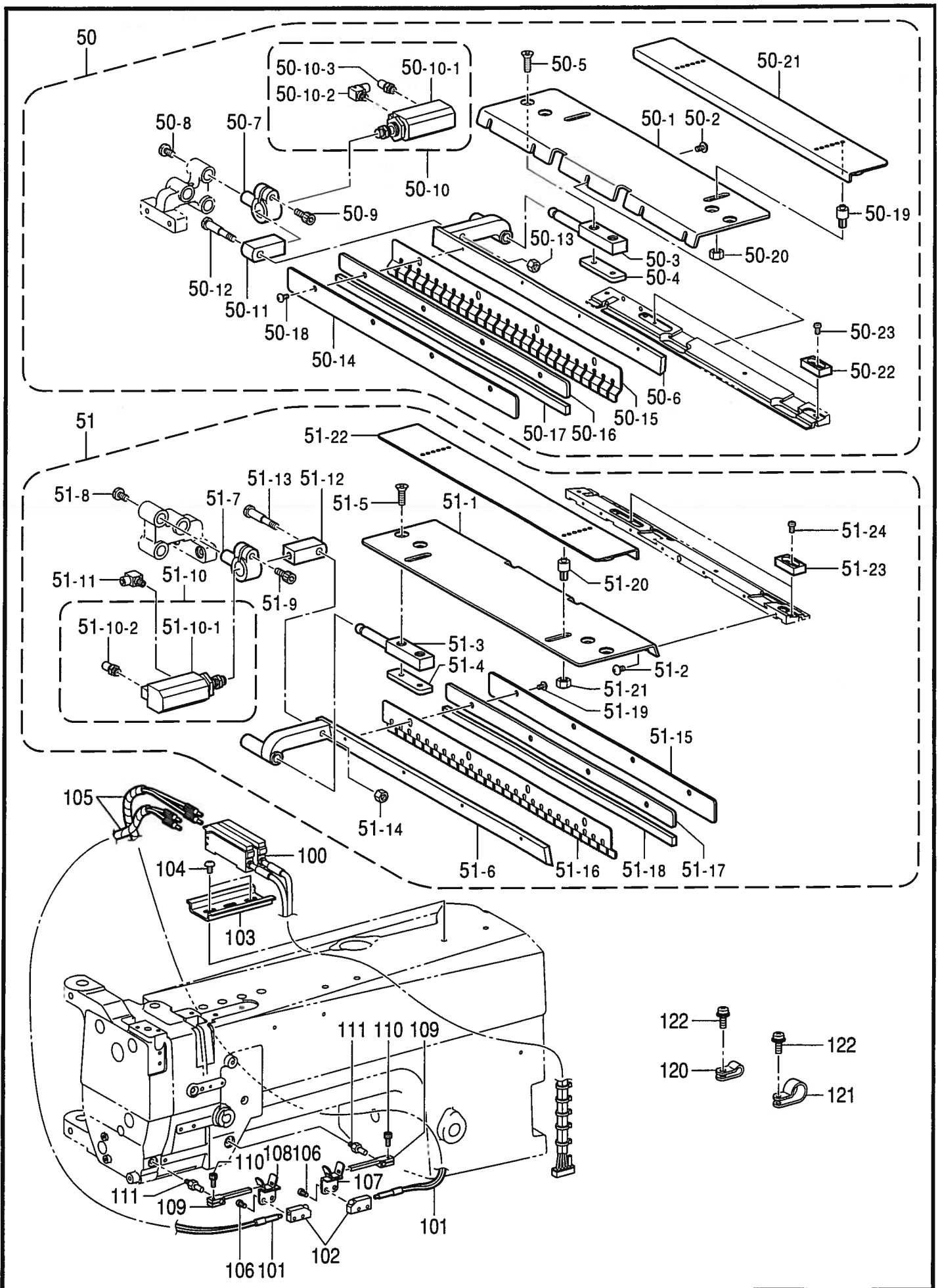

V2.布制御関係(オプション部品) / Cloth control system mechanism (Option parts)

| REF.NO  | CODE      | Q'TY | ヒンメイ          | NAME OF PARTS       | RM |
|---------|-----------|------|---------------|---------------------|----|
| 50      | S53565000 | 1    | フラップオサIRクミ    | FLAP CLAMP ASSY, R  |    |
| 50-1    | S53566000 | 1    | オオサIホジヨイタ     | AUXILIARY PLATE     |    |
| 50-2    | 008400604 | 5    | トラスコ4X6       | SCREW, TRUSS M4X6   |    |
| 50-3    | S53567001 | 1    | フラップシテンジク     | FULCRUM SHAFT       |    |
| 50-4    | S53568001 | 1    | ウラナツトM5       | NUT PLATE, M5       |    |
| 50-5    | 004501606 | 2    | サラコ5X16       | SCREW, FLAT M5X16   |    |
| 50-6    | S53569001 | 1    | フラップオサIR      | FLAP CLAMP, R       |    |
| 50-7    | S53540001 | 1    | シリンターダイ       | CYLINDER BASE       |    |
| 50-8    | 115503001 | 1    | シメネジ 4.37     | SCREW, SM4.37       |    |
| 50-9    | 018501036 | 1    | アナホルト5X10     | BOLT, SOCKET M5X10  |    |
| 50-10   | S53541000 | 1    | シリンタークミ       | CYLINDER ASSY       |    |
| 50-10-1 | S14666000 | 1    | シリンター 16X20   | CYLINDER, 16X20     |    |
| 50-10-2 | S12150000 | 1    | ホスエルホ M-5HL-4 | TUBE ELBOW, M-5HL-4 |    |
| 50-10-3 | S53542000 | 1    | ツキテM5H4       | JOINT, W/SCREW M5   |    |
| 50-11   | S53571001 | 1    | シリンターツキテ      | JOINT               |    |
| 50-12   | S53572001 | 1    | ダンネジ          | SHOULDER SCREW, M5  |    |
| 50-13   | 021500216 | 1    | 2シユナツト5       | NUT, 2 M5           |    |
| 50-14   | S53573001 | 1    | フラップオサIフレートA  | FLAP CLAMP BLADE, A |    |
| 50-15   | S53574000 | 1    | フラップオサIフレートB  | FLAP CLAMP BLADE, B |    |
| 50-16   | S53575001 | 1    | フラップオサIフレートC  | FLAP CLAMP BLADE, C |    |
| 50-17   | S53989000 | 1    | フラップオサIスポンジ   | SPONGE, 258X8X3     |    |
| 50-18   | 008300604 | 4    | トラスコ3X6       | SCREW, TRUSS M3X6   |    |
| 50-19   | S53576001 | 2    | スタット8         | STUD, 8 W/SCREW M5  |    |
| 50-20   | 021500216 | 2    | 2シユナツト5       | NUT, 2 M5           |    |
| 50-21   | S53577000 | 1    | フラップゲージクミ     | FLAP GAUGE ASSY     |    |
| 50-22   | S53580001 | 2    | フラップストツパ      | FLAP STOPPER        |    |
| 50-23   | 002300603 | 2    | ナベコ3X6        | SCREW, PAN M3X6     |    |
| 51      | S53581000 | 1    | フラップオサELクミ    | FLAP CLAMP ASSY, L  |    |
| 51-1    | S53566000 | 1    | オオサIホジヨイタ     | AUXILIARY PLATE     |    |
| 51-2    | 008400604 | 5    | トラスコ4X6       | SCREW, TRUSS M4X6   |    |
| 51-3    | S53567001 | 1    | フラップシテンジク     | FULCRUM SHAFT       |    |
| 51-4    | S53568001 | 1    | ウラナツトM5       | NUT PLATE, M5       |    |
| 51-5    | 004501606 | 2    | サラコ5X16       | SCREW, FLAT M5X16   |    |
| 51-6    | S53582001 | 1    | フラップオサEL      | FLAP CLAMP, L       |    |
| 51-7    | S53540001 | 1    | シリンターダイ       | CYLINDER BASE       |    |
| 51-8    | 115503001 | 1    | シメネジ 4.37     | SCREW, SM4.37       |    |
| 51-9    | 018501036 | 1    | アナホルト5X10     | BOLT, SOCKET M5X10  |    |
| 51-10   | S53541000 | 1    | シリンタークミ       | CYLINDER ASSY       |    |
| 51-10-1 | S14666000 | 1    | シリンター 16X20   | CYLINDER, 16X20     |    |
| 51-10-2 | S12150000 | 1    | ホスエルホ M-5HL-4 | TUBE ELBOW, M-5HL-4 |    |
| 51-11   | S53542000 | 1    | ツキテM5H4       | JOINT, W/SCREW M5   |    |
| 51-12   | S53571001 | 1    | シリンターツキテ      | JOINT               |    |
| 51-13   | S53572001 | 1    | ダンネジ          | SHOULDER SCREW, M5  |    |
| 51-14   | 021500216 | 1    | 2シユナツト5       | NUT, 2 M5           |    |
| 51-15   | S53573001 | 1    | フラップオサIフレートA  | FLAP CLAMP BLADE, A |    |
| 51-16   | S53574000 | 1    | フラップオサIフレートB  | FLAP CLAMP BLADE, B |    |
| 51-17   | S53575001 | 1    | フラップオサIフレートC  | FLAP CLAMP BLADE, C |    |
| 51-18   | S53989000 | 1    | フラップオサIスポンジ   | SPONGE, 258X8X3     |    |
| 51-19   | 008300604 | 4    | トラスコ3X6       | SCREW, TRUSS M3X6   |    |
| 51-20   | S53576001 | 2    | スタット8         | STUD, 8 W/SCREW M5  |    |
| 51-21   | 021500216 | 2    | 2シユナツト5       | NUT, 2 M5           |    |
| 51-22   | S53577000 | 1    | フラップゲージクミ     | FLAP GAUGE ASSY     |    |
| 51-23   | S53580001 | 2    | フラップストツパ      | FLAP STOPPER        |    |
| 51-24   | 002300603 | 2    | ナベコ3X6        | SCREW, PAN M3X6     |    |
| 100     | S52454000 | 1    | フラップセンサ       | FLAP SENSOR         |    |
| 101     | S52961000 | 2    | ファイバFD-G4     | FIBER, FD-G4        |    |
| 102     | S52962000 | 2    | サイドレンズFX-MR5  | SIDE LENS           |    |
| 103     | S52965001 | 1    | DINレール75      | DIN RAIL, 75        |    |
| 104     | 008400604 | 2    | トラスコ4X6       | SCREW, TRUSS M4X6   |    |
| 105     | S53588000 | 2    | スパイラル720SS    | SPIRAL, 720SS       |    |
| 106     | 002300603 | 4    | ナベコ3X6        | SCREW, PAN M3X6     |    |

V2 . 布制御関係 (オプション部品) / Cloth control system mechanism (Option parts)

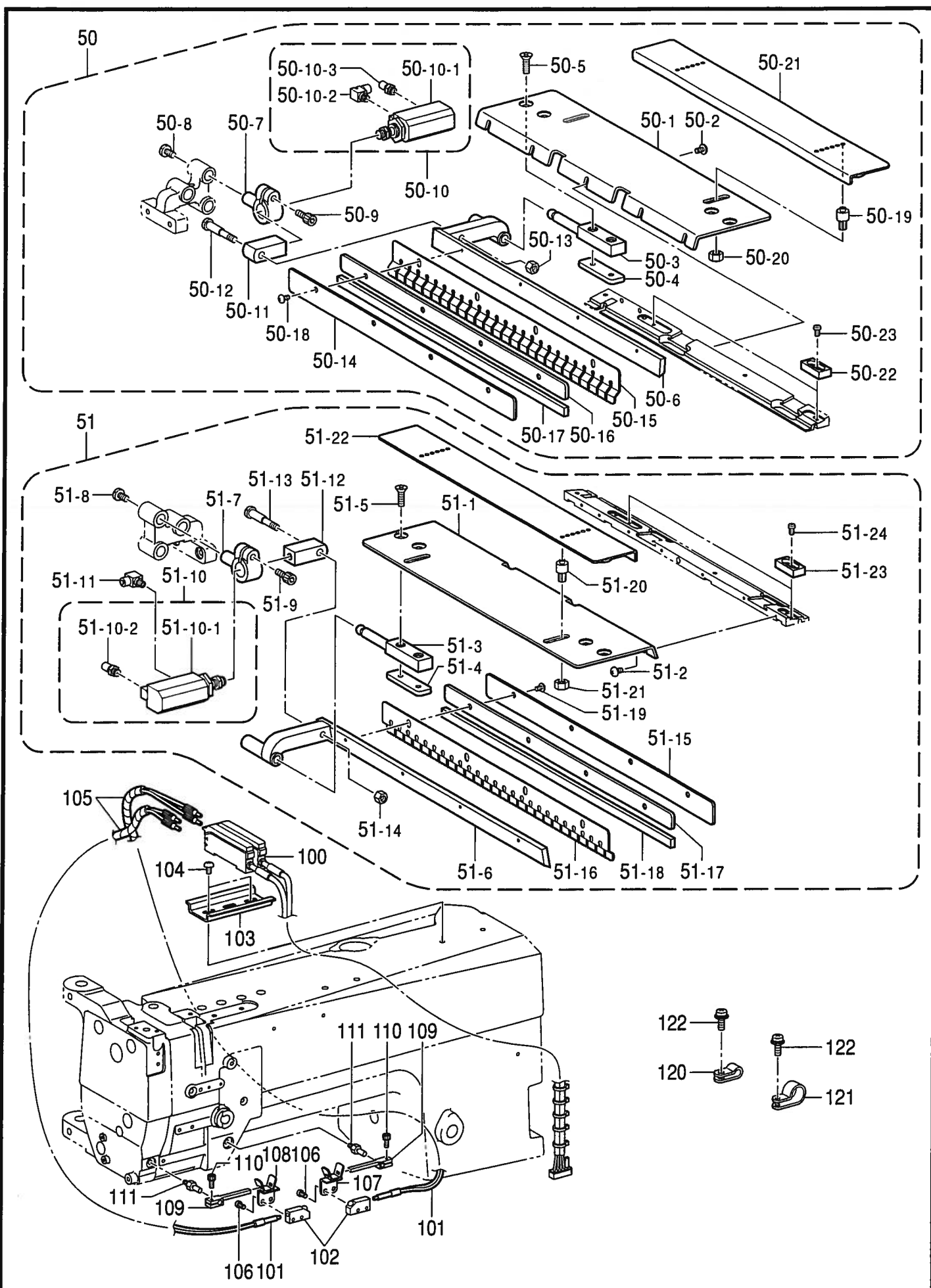

151-615-516

V2. 布制御関係(オプション部品) / Cloth control system mechanism (Option parts)

| REF.NO | CODE      | Q'TY | ヒンメイ           | NAME OF PARTS                | RM |
|--------|-----------|------|----------------|------------------------------|----|
| 107    | S53583000 | 1    | センサーホルダー R     | SENSOR HOLDER, R             |    |
| 108    | S53584000 | 1    | センサーホルダー L     | SENSOR HOLDER, L             |    |
| 109    | S53585001 | 2    | フラップセンサーガイド    | SENSOR GUIDE                 |    |
| 110    | 018300636 | 2    | アナボルト3X6       | BOLT, SOCKET M3X6            |    |
| 111    | S53586001 | 2    | センサースタッド       | SENSOR STUD, M5              |    |
| 120    | S10243000 | 1    | ナイロンクランプ NK-3N | CORD HOLDER, ;NK-3N          |    |
| 121    | 149287000 | 1    | ナイロンクランプ       | CORD HOLDER, 7N              |    |
| 122    | 0A5400805 | 2    | ナハサクミ4X8DB     | SCREW, PAN (S/P WASHER) M4X8 |    |

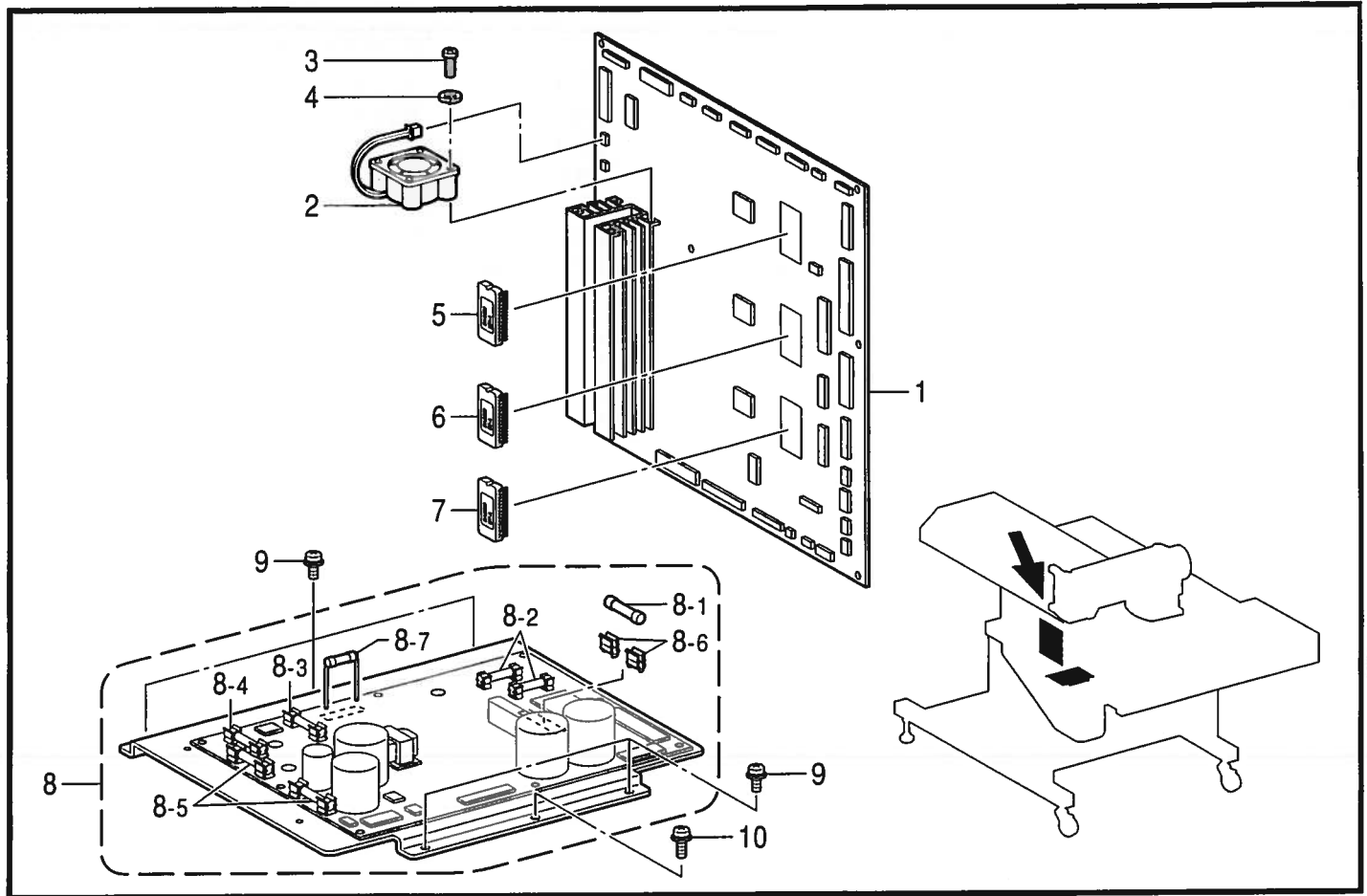

151-615-518

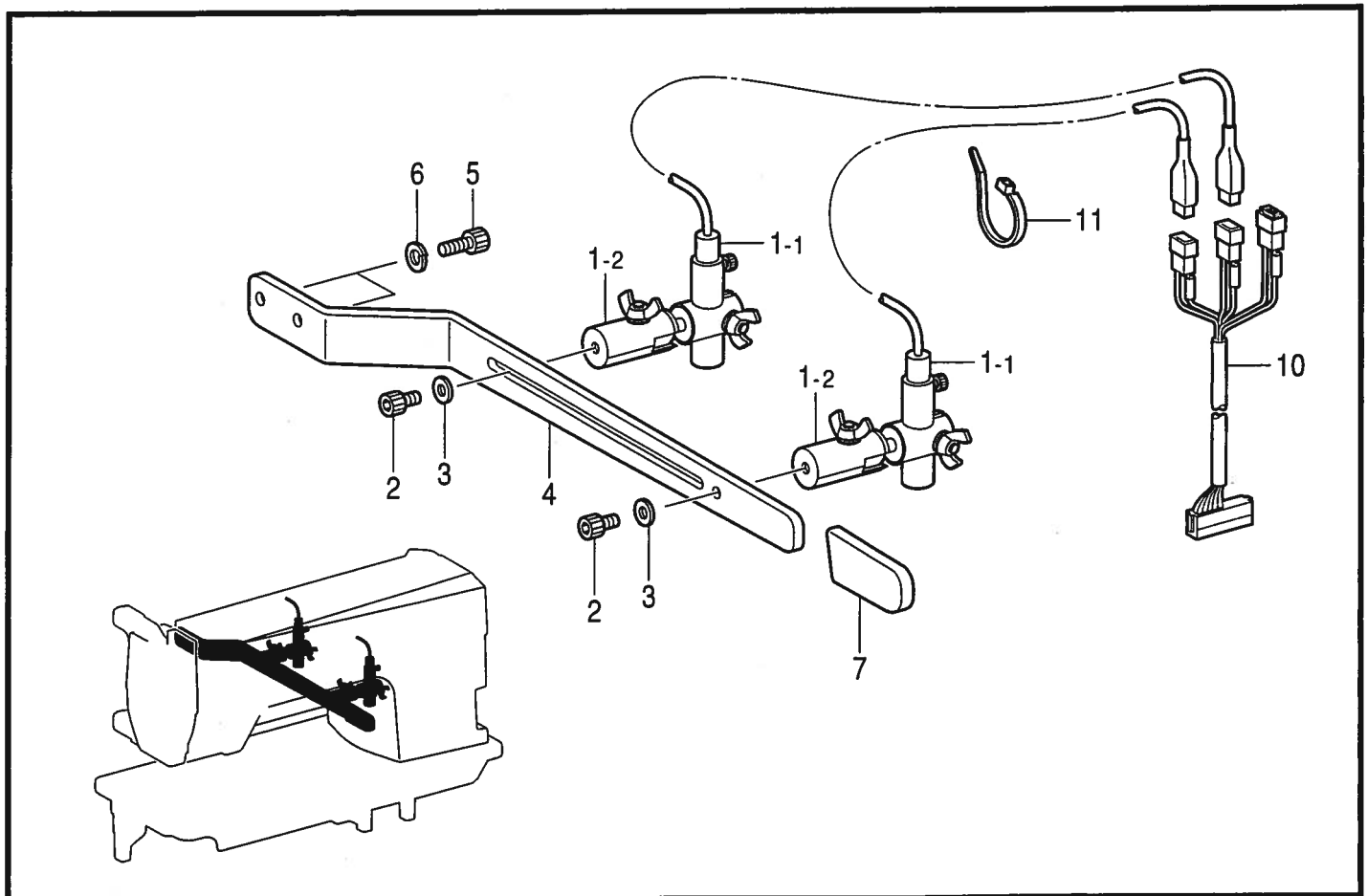

151-615-521

W. プリント基板関係 / Printed circuit board mechanism

| REF.NO | CODE      | Q'TY | ヒンメイ          | NAME OF PARTS                 | RM |
|--------|-----------|------|---------------|-------------------------------|----|
| 1      | S53000001 | 1    | メインバンクミ       | MAIN PCB ASSY                 |    |
| 2      | S52963000 | 1    | ファンKD2404     | FAN, KD2404                   |    |
| 3      | 062302506 | 2    | ナットM3X25      | SCREW, PAN M3X25              |    |
| 4      | 028030242 | 2    | ワッシャースプリング2-3 | WASHER, SPRING 2-3            |    |
| 5      | S52749000 | 1    | PROM620メイン    | PROM, BAS620 ;MAIN            |    |
| 6      | S52750000 | 1    | PROM620ホウセイ   | PROM, BAS620 ;SEW             |    |
| 7      | S52751000 | 1    | PROM620モータ    | PROM, BAS620 ;MT              |    |
| 8      | S53007001 | 1    | 電源バンクミ        | POWER SUPPLY PCB ASSY         |    |
| 8-1    | 152566000 | 1    | ヒューズC         | FUSE, C ;2A/125V              |    |
| 8-2    | 152565000 | 2    | ヒューズB         | FUSE, B ;5A/125V              |    |
| 8-3    | S52741000 | 1    | GFUSE6A125V   | GLASS FUSE, 6A/125V           |    |
| 8-4    | S08030000 | 1    | ヒューズ5AFB      | FUSE, 5A ;FB                  |    |
| 8-5    | 153242000 | 2    | ヒューズ6A        | FUSE, 6A                      |    |
| 8-6    | S30229000 | 14   | ヒューズホルダF219P  | FUSE HOLDER, ;F219P           |    |
| 8-7    | J02727001 | 1    | ガラスヒューズ2A250V | GLASS FUSE, 2A/250V           |    |
| 9      | 0A5400805 | 5    | ナットM4X8DB     | SCREW, PAN (S/P WASHER) M4X8  |    |
| 10     | 0A5401205 | 1    | ナットM4X12DB    | SCREW, PAN (S/P WASHER) M4X12 |    |

151-615-518

X. マーカー関係 / Marker mechanism

| REF.NO | CODE      | Q'TY | ヒンメイ          | NAME OF PARTS            | RM |
|--------|-----------|------|---------------|--------------------------|----|
| 1      | S52989000 | 2    | マーカー1クミ       | MARKING LIGHT ASSY, 1    |    |
| 1-1    | S52465000 | 2    | マーカー1         | MARKING LIGHT, 1         |    |
| 1-2    | S57942000 | 2    | マーキングホルダ      | MARKING FOLDER           |    |
| 2      | 018400836 | 2    | ボルトM4X8       | BOLT, SOCKET M4X8        |    |
| 3      | 025040236 | 2    | ワッシャ平M4       | WASHER, PLAIN M 4        |    |
| 4      | S57620001 | 1    | マーカーベースプレート   | MARKING LIGHT BASE PLATE |    |
| 5      | 018501236 | 2    | ボルトM5X12      | BOLT, SOCKET M5X12       |    |
| 6      | 028050246 | 2    | ワッシャースプリング2-5 | WASHER, SPRING 2-5       |    |
| 7      | S40494000 | 1    | スイッチキャップ      | SWITCH CAP               |    |
| 10     | S52985000 | 1    | ライトマーカーハーネスL  | ML-HARNESS, L ;M/PCB-ML  |    |
| 11     | S04557000 | 1    | バンドPLT1M      | BAND, PLT1M              |    |

151-615-521

Y. 操作パネル関係 / Operation panel mechanism

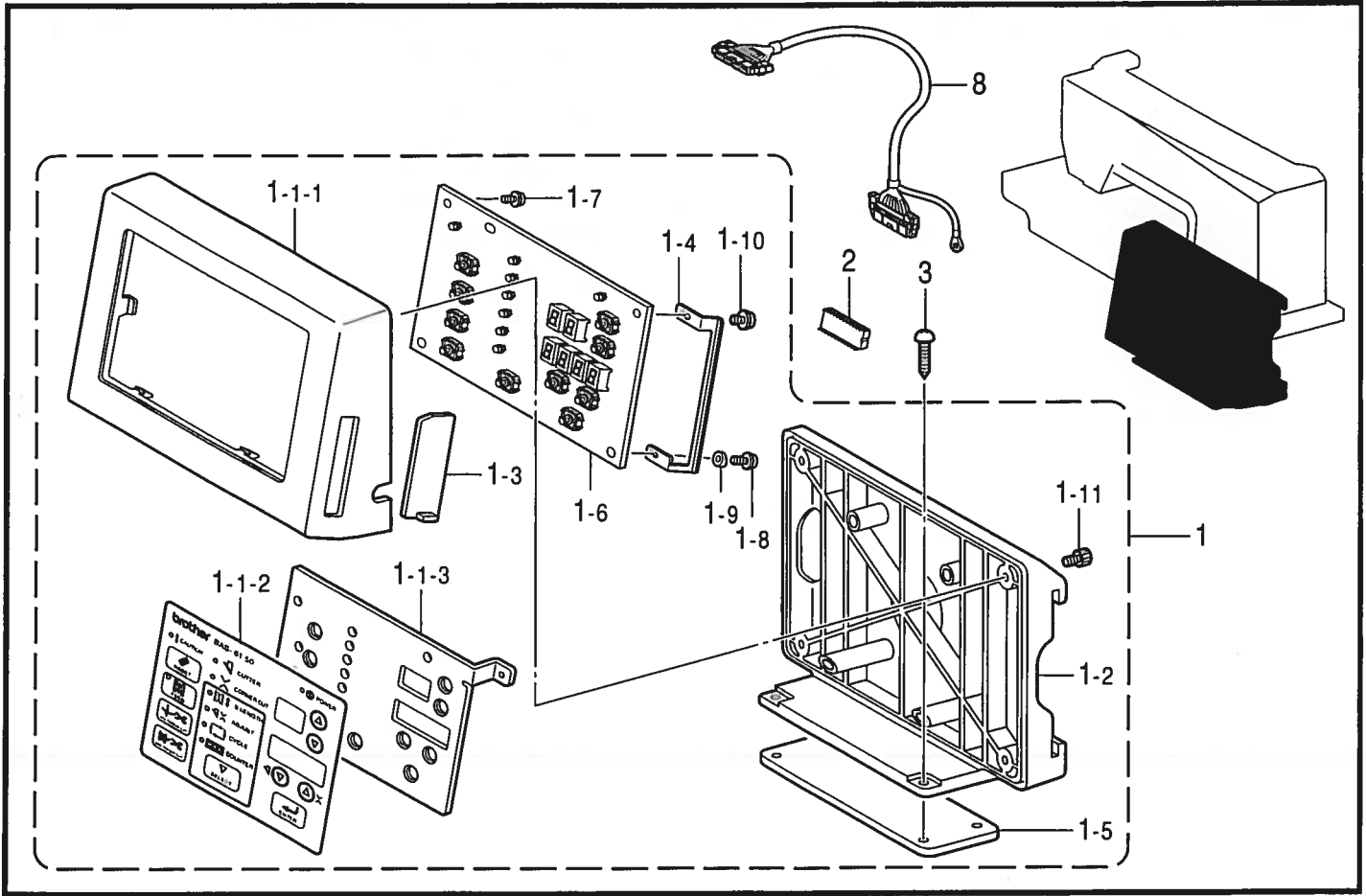

151-615-530

AA. 踏板関係 / Foot switch pedal mechanism

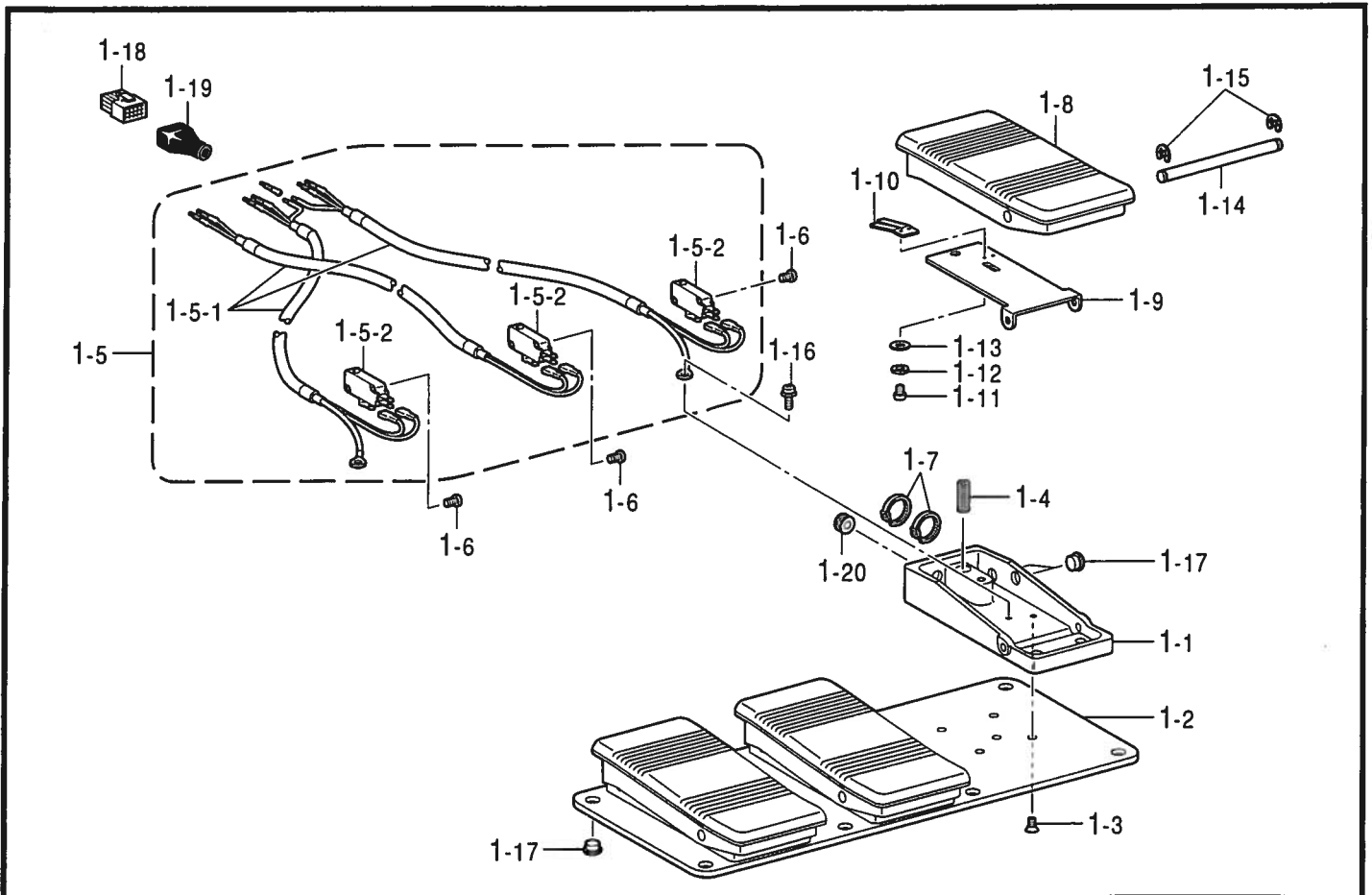

151-615-651



Y.操作パネル関係 / Operation panel mechanism

| REF.NO | CODE      | Q'TY | ヒンメイ           | NAME OF PARTS                | RM |
|--------|-----------|------|----------------|------------------------------|----|
| 1      | S52975001 | 1    | ソウサハ°ネル615クミ   | OPERATION PANEL ASSY, 615    |    |
| 1-1    | S52976000 | 1    | ハ°ネルマエフレームクミ   | FRONT FRAME ASSY             |    |
| 1-1-1  | S49491000 | 1    | ソウサハ°ネルマエフレーム  | FRONT FRAME                  |    |
| 1-1-2  | S52977000 | 1    | ハ°ネルシート        | PANEL SHEET                  |    |
| 1-1-3  | S52978000 | 1    | ハ°ネルシートウライタ    | PANEL SHEET BACK PLATE       |    |
| 1-2    | S52979000 | 1    | ソウサハ°ネルウシロ     | REAR FRAME                   |    |
| 1-3    | S49495000 | 1    | ハ°ネルヨコカハ°-     | PANEL SIDE COVER             |    |
| 1-4    | S49496001 | 1    | ハ°ネルヨコカハ°-ガイド° | COVR GUIDE, ;SIDE            |    |
| 1-5    | S52092000 | 1    | ゴムシート          | RUBBER SHEET                 |    |
| 1-6    | S53010001 | 1    | ハ°ネルキハ°ンクミ     | PANEL PCB ASSY               |    |
| 1-7    | 087310815 | 2    | カツフ°Bタイト3X8    | TAPTITE, CUP B M3X8          |    |
| 1-8    | 087311015 | 2    | カツフ°Bタイト3X10   | TAPTITE, CUP B M3X10         |    |
| 1-9    | XA2220050 | 2    | キハ°ンオサエ        | BOARD PRESSER                |    |
| 1-10   | 0A4400805 | 1    | +ナハ°サ°クミ4X8DA  | SCREW, PAN (S/P WASHER) M4X8 |    |
| 1-11   | 018300636 | 4    | アナホ°ルト3X6      | BOLT, SOCKET M3X6            |    |
| 2      | S52980000 | 1    | PROM6150ハ°ネル   | PANEL PROM 6150              |    |
| 3      | 032422505 | 4    | +マルモクネシ°4.1X25 | WOOD SCREW, ROUND M4.1X25    |    |
| 8      | S52458000 | 1    | ハ°ネルハ°ネス       | PANEL HARNESS                |    |

151-615-530

AA.踏板関係 / Foot switch pedal mechanism

| REF.NO | CODE      | Q'TY | ヒンメイ            | NAME OF PARTS                | RM |
|--------|-----------|------|-----------------|------------------------------|----|
| 1      | S52960001 | 1    | 3レンフツトSW        | 3-PEDAL FOOT SWITCH          |    |
| 1-1    | S38166000 | 3    | フツトハ°タルタ°イ      | FOOT PEDAL BASE              |    |
| 1-2    | S42867001 | 1    | フミイタホシ°ヨイタ      | TREADLE AUXILIARY PLATE      |    |
| 1-3    | 004400603 | 6    | +サラコネシ°4X6      | SCREW, FLAT M4X6             |    |
| 1-4    | S38170001 | 3    | フツトハ°タルハ°ネ      | SPRING, COMPRESSION          |    |
| 1-5    | S52959000 | 1    | 3レンフツトSWハ°ネスクミ  | 3-PEDAL FOOT SW HARNESS ASSY |    |
| 1-5-1  | S44807000 | 1    | 3レンフツトSWハ°ネス    | 3-PEDAL FOOT SW HARNESS      |    |
| 1-5-2  | S36260000 | 3    | スイツチVXヒ°ンホ°タン   | MICRO SWITCH, VX ;PIN BUTTON |    |
| 1-6    | 062301205 | 6    | ナハ°コ3X12        | SCREW, PAN M3X12             |    |
| 1-7    | 228475000 | 10   | ケツソクハ°ント°1.9X80 | FASTENING BAND, 1.9X80       |    |
| 1-8    | S38174000 | 3    | フツトハ°タル         | FOOT PEDAL                   |    |
| 1-9    | S38175001 | 3    | ハ°タルホコ°イタ       | PROTECTION PLATE, ;PEDAL     |    |
| 1-10   | S38176101 | 3    | スイツチオサエハ°ネ      | SPRING, PLATE                |    |
| 1-11   | 002300403 | 6    | +ナハ°コ3X4        | SCREW, PAN M3X4              |    |
| 1-12   | 028030246 | 6    | ハ°ネサ°カ°ネ2-3     | WASHER, SPRING 2-3           |    |
| 1-13   | 025030236 | 6    | ヒラサ°カ°ネチユウ3     | WASHER, PLAIN M 3            |    |
| 1-14   | S38177001 | 3    | フツトハ°タルシ°ク      | SHAFT, ;F-PEDAL              |    |
| 1-15   | 048050346 | 6    | トメ7E5           | STOP RING                    |    |
| 1-16   | 052400606 | 3    | ナハ°コハ°ネヒラ4X6    | SCREW, PAN (S/P WASHER) M4X6 |    |
| 1-17   | 117936001 | 14   | ゴムセン9.4         | RUBBER CAP, 9.4              |    |
| 1-18   | S52957000 | 1    | コネクタ172171-1    | CONNECTOR, 172172-1          |    |
| 1-19   | S52958000 | 1    | コネクタカハ°-527163  | CONNECTOR COVER, 527163      |    |
| 1-20   | S38059000 | 3    | ク°ロメツトNG79F     | RUBBER CAP, ;NG79F           |    |

151-615-651

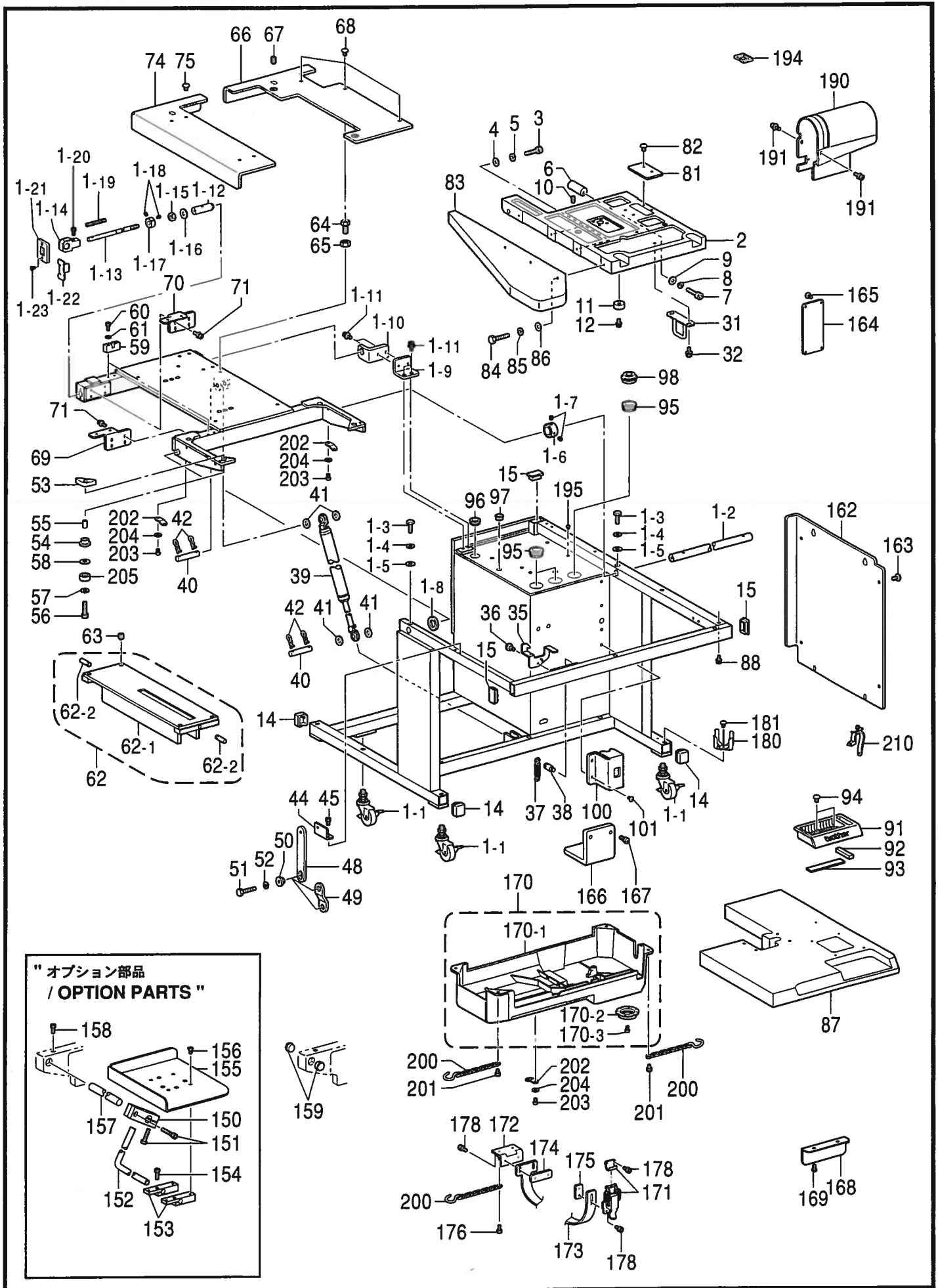

AB.動力台関係 / Power table

| REF.NO | CODE      | Q'TY | ヒンメイ           | NAME OF PARTS                    | RM |
|--------|-----------|------|----------------|----------------------------------|----|
| 1-1    | S40884000 | 4    | ストツハ°ツキヤスタ-100 | CASTER W/STOPPER, 100            |    |
| 1-2    | S53624001 | 1    | トウフ°シテンシ°ク     | FULCRUM SHAFT, H                 |    |
| 1-3    | 017082016 | 2    | ホ°ルト8X20       | BOLT, M8X20                      |    |
| 1-4    | 028080246 | 2    | ハ°ネサ°カ°ネ2-8    | WASHER, SPRING 2-8               |    |
| 1-5    | 025080236 | 2    | ヒラサ°カ°ネチユウ8    | WASHER, PLAIN M 8                |    |
| 1-6    | S53625001 | 1    | セツトカラ24        | SET SCREW COLLAR                 |    |
| 1-7    | 012060636 | 2    | アナヒラ6X6        | SET SCREW, SOCKET (FT) M6X6      |    |
| 1-8    | S53626001 | 1    | スハ°-サ24        | SPACER, 24                       |    |
| 1-9    | S57538001 | 1    | シシ°イタA         | SUPPORT PLATE, A                 |    |
| 1-10   | S57539001 | 1    | シシ°イタB         | SUPPORT PLATE, B                 |    |
| 1-11   | S42446001 | 4    | アナホ°ルトサ°クミ6X14 | BOLT, SOCKET (S/P WASHER)M6X14   |    |
| 1-12   | S53633001 | 1    | フレ-ムササエシ°ク     | SUPPORT SHAFT, F                 |    |
| 1-13   | S53634001 | 1    | ヒツハ°リシ°ク       | SHAFT W/SCREW                    |    |
| 1-14   | S53635001 | 1    | ササエシ°クストツハ°-   | SHAFT STOPEER                    |    |
| 1-15   | 021080206 | 1    | 2シユナツト8        | NUT, 2 M8                        |    |
| 1-16   | 025080336 | 1    | ヒラサ°カ°ネタ°イ8    | WASHER, PLAIN L 8                |    |
| 1-17   | S42619001 | 1    | セツトカラ-         | SET SCREW COLLAR                 |    |
| 1-18   | 012400436 | 1    | アナヒラ4X4        | SET SCREW, SOCKET (FT) M4X4      |    |
| 1-19   | 153568001 | 1    | オサエハ°ネA        | SPRING, A ;COMPRESSION           |    |
| 1-20   | 018401236 | 1    | アナホ°ルト4X12     | BOLT, SOCKET M4X12               |    |
| 1-21   | S53636001 | 1    | ハ°ネオサIA        | SPRING HOLDER, A                 |    |
| 1-22   | S53637001 | 2    | ハ°ネオサIB        | SPRING HOLDER, B                 |    |
| 1-23   | 004401003 | 2    | +サラネシ°4X10     | SCREW, FLAT M4X10                |    |
| 2      | S53627101 | 1    | テ-ブル           | TABLE                            |    |
| 3      | 018102036 | 2    | アナホ°ルト10X20    | BOLT, SOCKET M10X20              |    |
| 4      | 025100236 | 2    | ヒラサ°カ°ネチユウ10   | WASHER, PLAIN L 10               |    |
| 5      | 028100246 | 2    | ハ°ネサ°カ°ネ2-10   | WASHER, SPRING 2-10              |    |
| 6      | S53628001 | 1    | ハ°ツツツナキ°シ°ク    | CONNECTING SHAFT                 |    |
| 7      | 018103036 | 1    | アナホ°ルト10X30    | BOLT, SOCKET M10X30              |    |
| 8      | 028100246 | 1    | ハ°ネサ°カ°ネ2-10   | WASHER, SPRING 2-10              |    |
| 9      | 025100236 | 1    | ヒラサ°カ°ネチユウ10   | WASHER, PLAIN L 10               |    |
| 10     | S07356001 | 1    | トメネシ°6.35ヒラ    | SET SCREW, (FT) SM6.35-28X17     |    |
| 11     | S53629000 | 2    | ゴムアシ           | RUBBER LEG                       |    |
| 12     | S55485001 | 2    | アナホ°ルトサ°クミ5X12 | SCREW, SOCKET (S/P W) M5X12      |    |
| 14     | S10661109 | 4    | ツトアシフタ°ゴム      | RUBBER                           |    |
| 15     | S03999009 | 3    | ハリキヤツプ         | BEAM CAP                         |    |
| 31     | S53638000 | 1    | ウケカナグ          | SUPPORT METAL FITTINGS           |    |
| 32     | S42466001 | 2    | アナホ°ルトサ°クミ6X14 | BOLT, SOCKET (S/P WASHER) M6X1 4 |    |
| 35     | S53639001 | 1    | フツク            | HOOK                             |    |
| 36     | 144526001 | 2    | ダンネシ°4.37      | SHOULDER SCREW, SM4.37           |    |
| 37     | 151951001 | 1    | ク°レハ°ヒキハ°ネ     | SPRING, EXTENSION                |    |
| 38     | S53640001 | 1    | ハ°ネカケ          | SPRING HOOK                      |    |
| 39     | S17971000 | 1    | ガ°スア°プリンク°     | SHOCK ABSORBER, GAS              |    |
| 40     | S49638001 | 2    | リンクシ°クD        | LINK SHAFT, D                    |    |
| 41     | 107153002 | 4    | サ°カ°ネ          | WASHER                           |    |
| 42     | S37968001 | 4    | スナツプ°ピン8       | SNAP PIN, 8                      |    |
| 44     | S53643001 | 1    | シジ°ダイD         | SUPPORT BASE, D                  |    |
| 45     | 018500836 | 2    | アナホ°ルト5X8      | BOLT, SOCKET M5X8                |    |
| 48     | S53644001 | 1    | トウフ°ササエレハ°-A   | LEVER, A                         |    |
| 49     | S53645001 | 1    | トウフ°ササエレハ°-B   | LEVER, B                         |    |
| 50     | 159027001 | 3    | オサエロ-ラ         | PRESSER ROLLER                   |    |
| 51     | 017061616 | 3    | ホ°ルト6X16       | BOLT, M6X16                      |    |
| 52     | 028060246 | 3    | ハ°ネサ°カ°ネ2-6    | WASHER, SPRING 2-6               |    |
| 53     | S53646000 | 4    | ハ°ツトウケ         | BED SUPPORT                      |    |
| 54     | S53647000 | 4    | クツシヨン          | CUSHION                          |    |
| 55     | S53648001 | 4    | クツシヨンカラ-       | CUSHIN COLLAR                    |    |
| 56     | 018063036 | 4    | アナホ°ルト6X30     | BOLT, SOCKET M6X30               |    |
| 57     | 028060246 | 4    | ハ°ネサ°カ°ネ2-6    | WASHER, SPRING 2-6               |    |
| 58     | 154886001 | 4    | サ°カ°ネ          | WASHER                           |    |
| 59     | S53649001 | 2    | テ-ブルイチキ°メイタ    | POSITIONING PLATE                |    |
| 60     | 018401636 | 4    | アナホ°ルト4X16     | BOLT, SOCKET M4X16               |    |

AB.動力台関係 / Power table

| REF.NO | CODE      | Q'TY | ヒンメイ                     | NAME OF PARTS                      | RM |
|--------|-----------|------|--------------------------|------------------------------------|----|
| 61     | 028040246 | 4    | ハネサカネ2-4                 | WASHER, SPRING 2-4                 |    |
| 62     | S53650000 | 1    | コーナーメステーブルクミ             | CORNER KNIFE TABLE ASSY            |    |
| 62-1   | S53651001 | 1    | コーナーメステーブル               | CORNER KNIFE TABLE                 |    |
| 62-2   | 118550001 | 2    | ミソツキピン                   | PIN, DOWEL                         |    |
| 63     | 012081636 | 4    | アナヒラ8X16                 | SET SCREW, SOCKET (FT) M8X16       |    |
| 64     | S53652001 | 3    | テーブルスペース                 | TABLE SPACER, W/SCREW              |    |
| 65     | 021080306 | 3    | ナット3シユ8                  | NUT, 3 M8                          |    |
| 66     | S53653000 | 1    | サブテーブルR                  | AUXILIARY TABLE, R                 |    |
| 67     | S53685001 | 2    | トメネジ8X16                 | SET SCREW, M8X16                   |    |
| 68     | 008400604 | 3    | トラスコ4X6                  | SCREW, TRUSS M4X6                  |    |
| 69     | S53654001 | 1    | サブテーブルブラケットA             | BRACKET, A                         |    |
| 70     | S53655001 | 1    | サブテーブルブラケットB             | BRACKET, B                         |    |
| 71     | S55485001 | 8    | アナホルトサクミ5X12             | SCREW, SOCKET (S/P W) M5X12        |    |
| 74     | S53656000 | 1    | サブテーブルL                  | AUXILIARY TABLE                    |    |
| 75     | 008400604 | 4    | トラスコ4X6                  | SCREW, TRUSS M4X6                  |    |
| 81     | S53659000 | 1    | キシスヘリイタC                 | SLIDE PLATE, C                     |    |
| 82     | 008400604 | 2    | トラスコ4X6                  | SCREW, TRUSS M4X6                  |    |
| 83     | S53660000 | 1    | テーブルL                    | TABLE, L                           |    |
| 84     | 017083016 | 3    | ホルト8X30                  | BOLT, M8X30                        |    |
| 85     | 028080246 | 3    | ハネサカネ2-8                 | WASHER, SPRING 2-8                 |    |
| 86     | 025080236 | 3    | ヒラサカネユウ8                 | WASHER, PLAIN M 8                  |    |
| 87     | S53661000 | 1    | テーブルR                    | TABLE, R                           |    |
| 88     | S55486001 | 4    | アナホルトサクミ5X14             | SCREW, SOCKET (S/P W) M5X14        |    |
| 91     | S02738009 | 1    | コモケース                    | ACCESSORY CASE                     |    |
| 92     | S02740000 | 1    | フェルト                     | FELT                               |    |
| 93     | S02739000 | 1    | ゴムシヤクテープ                 | RUBBER MAGNET TAPE                 |    |
| 94     | 039411215 | 2    | 1トラスタツビン4X12             | TAPPING SCREW, TRUSS 1 M4X12       |    |
| 95     | S38820000 | 3    | ブツユ35                    | BUSHING, 35                        |    |
| 96     | S46583000 | 1    | ブツユTB-2533               | BUSHING, TB-2533                   |    |
| 97     | S52970000 | 1    | ブツユTB-1116               | BUSHING, TB-1116                   |    |
| 98     | S40583000 | 1    | ホルプラグ35                  | HOLE PLUGE, 35                     |    |
| 100    | S55310001 | 1    | ブレーカカバー                  | BREAKER COVER                      |    |
| 101    | 008400604 | 2    | トラスコ4X6                  | SCREW, TRUSS M4X6                  |    |
| 150    | S53671000 | 1    | <オプション部品><br>ウケサラホジブラケット | <OPTION PARTS><br>HOLDEING BRACKET |    |
| 151    | 018082036 | 2    | アナホルト8X20                | BOLT, SOCKET M8X20                 |    |
| 152    | S53672000 | 1    | ウケサラホジシク                 | CURVED BAR                         |    |
| 153    | S53673000 | 2    | キシウケジヨイント                | FIXING BLOCK                       |    |
| 154    | 018501436 | 2    | アナホルト5X14                | BOLT, SOCKET M5X14                 |    |
| 155    | S53674000 | 1    | キシウケ                     | CLOTH SUPPORTER                    |    |
| 156    | 004401003 | 4    | +サラネジ4X10                | SCREW, FLAT M4X10                  |    |
| 157    | S54117001 | 1    | リンクシテンシク                 | FULCRUM SHAFT                      |    |
| 158    | 018501022 | 1    | アナホルト5X10                | BOLT, SOCKET M5X10                 |    |
| 159    | 159150000 | 2    | ゴムセン20.5                 | RUBBER CAP, 20.5                   |    |
| 162    | S53675001 | 1    | ボックスカバー                  | BOX COVER                          |    |
| 163    | 008400604 | 8    | トラスコ4X6                  | SCREW, TRUSS M4X6                  |    |
| 164    | S53676001 | 1    | アームカバー                   | ARM COVER                          |    |
| 165    | 008400604 | 4    | トラスコ4X6                  | SCREW, TRUSS M4X6                  |    |
| 166    | S55308001 | 1    | スイッチカバー                  | SWITCH COVER                       |    |
| 167    | 0A5401006 | 2    | ナベコバネヒラ4X10              | SCREW, PAN (S/P WASHER) M4X10      |    |
| 168    | S53691001 | 1    | オイルフェンス                  | OIL FENCE                          |    |
| 169    | 105173004 | 2    | シメネジ4.76                 | SCREW, SM4.76                      |    |
| 170    | S53677000 | 1    | アブラウケBASクミ               | OIL PAN ASSY, BAS                  |    |
| 170-1  | S53678001 | 1    | アブラウケBAS                 | OIL PAN, BAS                       |    |
| 170-2  | 153230101 | 1    | オイルニガシグチ                 | DRAIN                              |    |
| 170-3  | 062670512 | 2    | ナベコ357-40X5              | SCREW, PAN SM3.57-40X5             |    |
| 171    | S53679000 | 1    | キャッチクリップ                 | CATCH CLIP                         |    |
| 172    | S53680000 | 1    | ヒョウハン                    | HINGE                              |    |
| 173    | S53681000 | 1    | アブラウケメバント                | BAND, 252X20X0.5                   |    |

AB.動力台関係 / Power table

| REF.NO | CODE      | Q'TY | ヒンメイ   | NAME OF PARTS              | RM |
|--------|-----------|------|--|----------------------------|----|
| 174    | S53682001 | 1    | ナツトA   | NUT PLATE, A               |    |
| 175    | S53683001 | 1    | ナツトB   | NUT PLATE, B               |    |
| 176    | 018300836 | 2    | アナボ <sup>ル</sup> ト3X8                        | BOLT, SOCKET M3X8          |    |
| 177    | 018300636 | 6    | アナボ <sup>ル</sup> ト3X6                        | BOLT, SOCKET M3X6          |    |
| 180    | 133172003 | 1    | ア <sup>ラ</sup> サ <sup>ン</sup> タ <sup>イ</sup> | BRACKET, ;OIL              |    |
| 181    | 008400604 | 1    | +トラスコ4X6                                     | SCREW, TRUSS M4X6          |    |
| 190    | S53684001 | 1    | BAS620モ <sup>ー</sup> タカバ <sup>ー</sup>        | MOTOR COVER, BAS620        |    |
| 191    | S55479001 | 2    | アナボ <sup>ル</sup> トサ <sup>ク</sup> ミ4X8        | SCREW, SOCKET (S/P W) M4X8 |    |
| 194    | S41964000 | 1    | ブ <sup>ツ</sup> シ                             | BUSH                       |    |
| 195    | 008400604 | 3    | +トラスコ4X6                                     | SCREW, TRUSS M4X6          |    |
| 200    | S53689001 | 3    | クサリクミ  | CHAIN ASSY                 |    |
| 201    | 018300636 | 2    | アナボ <sup>ル</sup> ト3X6                        | BOLT, SOCKET M3X6          |    |
| 202    | S53690001 | 3    | フツクカケ  | HOOK HOLDER                |    |
| 203    | 062400805 | 3    | ナ <sup>ハ</sup> コ4X8                          | SCREW, 4X8                 |    |
| 204    | 028040246 | 3    | ハ <sup>ネ</sup> サ <sup>カ</sup> ネ2-4           | WASHER, SPRING 2-4         |    |
| 205    | S08205000 | 4    | クヅシヨ   | CUSHION                    |    |
| 210    | S39821000 | 7    | コ <sup>ト</sup> クラン <sup>プ</sup> 19P7         | CORD CLAMP, 19P7           |    |

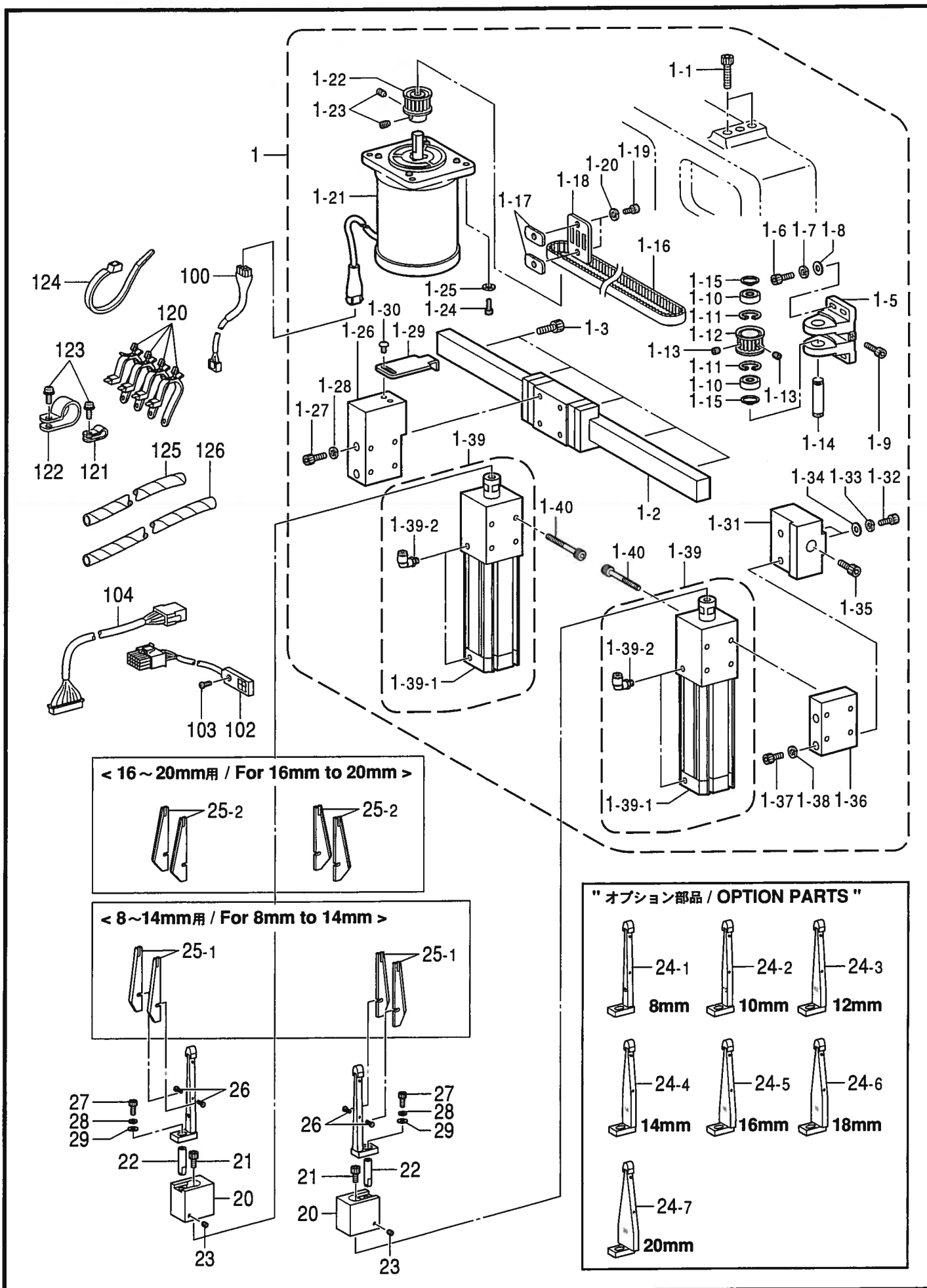

## AC.コーナーメス関係 / Corner knife mechanism

| REF.NO | CODE      | Q'TY | ヒンメイ          | NAME OF PARTS                  | RM |
|--------|-----------|------|---------------|--------------------------------|----|
| 1      | S53700000 | 1    | コーナーメスドライブアキミ | CORNER KNIFE DRIVING ASSY, A   |    |
| 1-1    | S42445001 | 4    | アナホルトソケット8X25 | BOLT, SOCKET (S/P WASHER)M8X25 |    |
| 1-2    | S53702000 | 1    | リニアガイド        | LINEAR GUIDE                   |    |
| 1-3    | 018062036 | 5    | アナホルト6X20     | BOLT, SOCKET M6X20             |    |
| 1-5    | S10133000 | 1    | Xプーリーベース      | X-PULLEY BASE, B               |    |
| 1-6    | 018501636 | 4    | アナホルト5X16     | BOLT, SOCKET M5X16             |    |
| 1-7    | 028050246 | 4    | ハネサカネ2-5      | WASHER, SPRING 2-5             |    |
| 1-8    | 025050236 | 4    | ヒラサカネ5        | WASHER, PLAIN M 5              |    |
| 1-9    | 018502036 | 1    | アナホルト5X20     | BOLT, SOCKET M5X20             |    |
| 1-10   | 530138001 | 2    | マイクロベアリング8    | MICRO BEARING, 8               |    |
| 1-11   | 048160242 | 2    | トメワナヨウC16     | RETAINING RING, INTERNAL C16   |    |
| 1-12   | S10087101 | 1    | タイミングプーリーB    | TIMING PULLEY, B               |    |
| 1-13   | 012400436 | 2    | アネヒラ4X4       | SET SCREW, SOCKET (FT) M4X4    |    |
| 1-14   | S10134001 | 1    | Xプーリーシャフト     | X-PULLEY SHAFT, B              |    |
| 1-15   | 048080142 | 2    | トメワナヨウC8      | RETAINING RING, C8             |    |
| 1-16   | S53703000 | 1    | タイミングベルト      | TIMING BELT                    |    |
| 1-17   | S10078001 | 2    | Tベルトスペーサ      | SPACER, T-BELT                 |    |
| 1-18   | S10079101 | 1    | ベルトホルダー       | BELT HOLDER                    |    |
| 1-19   | 018401036 | 2    | アナホルト4X10     | BOLT, SOCKET M4X10             |    |
| 1-20   | 028040246 | 2    | ハネサカネ2-4      | WASHER, SPRING 2-4             |    |
| 1-21   | S43192200 | 1    | パルスモータアキミ     | PULSE MOTOR ASSY, X            |    |
| 1-22   | S27844201 | 1    | タイミングプーリーA    | TIMING PULLEY, A               |    |
| 1-23   | 014770622 | 2    | アネメネジ6.35ホネミ  | SET SCREW, SOCKET (CP) SM6.35  |    |
| 1-24   | 018401236 | 4    | アナホルト4X12     | BOLT, SOCKET M4X12             |    |
| 1-25   | 028040243 | 4    | ハネサカネ2-4      | WASHER, SPRING 2-4             |    |
| 1-26   | S53705001 | 1    | シリンダササIL      | CYLINDER SUPPORT, L            |    |
| 1-27   | 018501636 | 2    | アナホルト5X16     | BOLT, SOCKET M5X16             |    |
| 1-28   | 028050246 | 2    | ハネサカネ2-5      | WASHER, SPRING 2-5             |    |
| 1-29   | S53706001 | 1    | センサードッグ       | SENSOR DOG                     |    |
| 1-30   | 008400604 | 2    | トラスコ4X6       | SCREW, TRUSS M4X6              |    |
| 1-31   | S53707001 | 1    | コテブロック        | FIXING BLOCK                   |    |
| 1-32   | 018501436 | 2    | アナホルト5X14     | BOLT, SOCKET M5X14             |    |
| 1-33   | 028040246 | 2    | ハネサカネ2-4      | WASHER, SPRING 2-4             |    |
| 1-34   | 025050236 | 2    | ヒラサカネ5        | WASHER, PLAIN M 5              |    |
| 1-35   | 018062036 | 1    | アナホルト6X20     | BOLT, SOCKET M6X20             |    |
| 1-36   | S53708001 | 1    | シリンダササER      | CYLINDER SUPPORT, R            |    |
| 1-37   | 018501236 | 2    | アナホルト5X12     | BOLT, SOCKET M5X12             |    |
| 1-38   | 028050246 | 2    | ハネサカネ2-5      | WASHER, SPRING 2-5             |    |
| 1-39   | S53709000 | 2    | シリンダ25X75ケミ   | CYLINDER ASSY, 25X75           |    |
| 1-39-1 | S53710000 | 2    | シリンダ25X75     | CYLINDER, 25X75                |    |
| 1-39-2 | S53734000 | 4    | エルボKQ2L06M5   | ELBOW, KQ2L06M5                |    |
| 1-40   | S32294001 | 8    | アナホルト4X35     | BOLT, SOCKET M4X35             |    |
| 20     | S57541001 | 2    | コーナーメスリッパダイ   | C-KNIFE SETTING BRACKET        |    |
| 21     | 018061436 | 2    | アナホルト6X14     | BOLT, SOCKET M6X14             |    |
| 22     | S14753001 | 2    | メスダイシャフト      | KNIFE BASE SHAFT               |    |
| 23     | 012500536 | 2    | アネヒラ5X5       | SET SCREW, SOCKET (FT) M5X5    |    |
|        |           |      | <オプション部品>     | <OPTION PARTS>                 |    |
| 24-1   | S11521001 | 2    | メスダイ8ケミ       | KNIFE BASE ASSY, 8             |    |
| 24-2   | S11522001 | 2    | メスダイ10ケミ      | KNIFE BASE ASSY, 10            |    |
| 24-3   | S11523001 | 2    | メスダイ12ケミ      | KNIFE BASE ASSY, 12            |    |
| 24-4   | S11524001 | 2    | メスダイ14ケミ      | KNIFE BASE ASSY, 14            |    |
| 24-5   | S11525001 | 2    | メスダイ16ケミ      | KNIFE BASE ASSY, 16            |    |
| 24-6   | S11526001 | 2    | メスダイ18ケミ      | KNIFE BASE ASSY, 18            |    |
| 24-7   | S11527001 | 2    | メスダイ20ケミ      | KNIFE BASE ASSY, 20            |    |
|        |           |      | <8 - 14mm用>   | <For 8mm to 14mm>              |    |
| 25-1   | S14050001 | 4    | セラミックコーナーメスS  | CERAMIC CORNER KNIFE, S        |    |
|        |           |      | <16 - 20mm用>  | <For 16mm to 20mm>             |    |
| 25-2   | S14051001 | 4    | セラミックコーナーメスL  | CERAMIC CORNER KNIFE, L        |    |

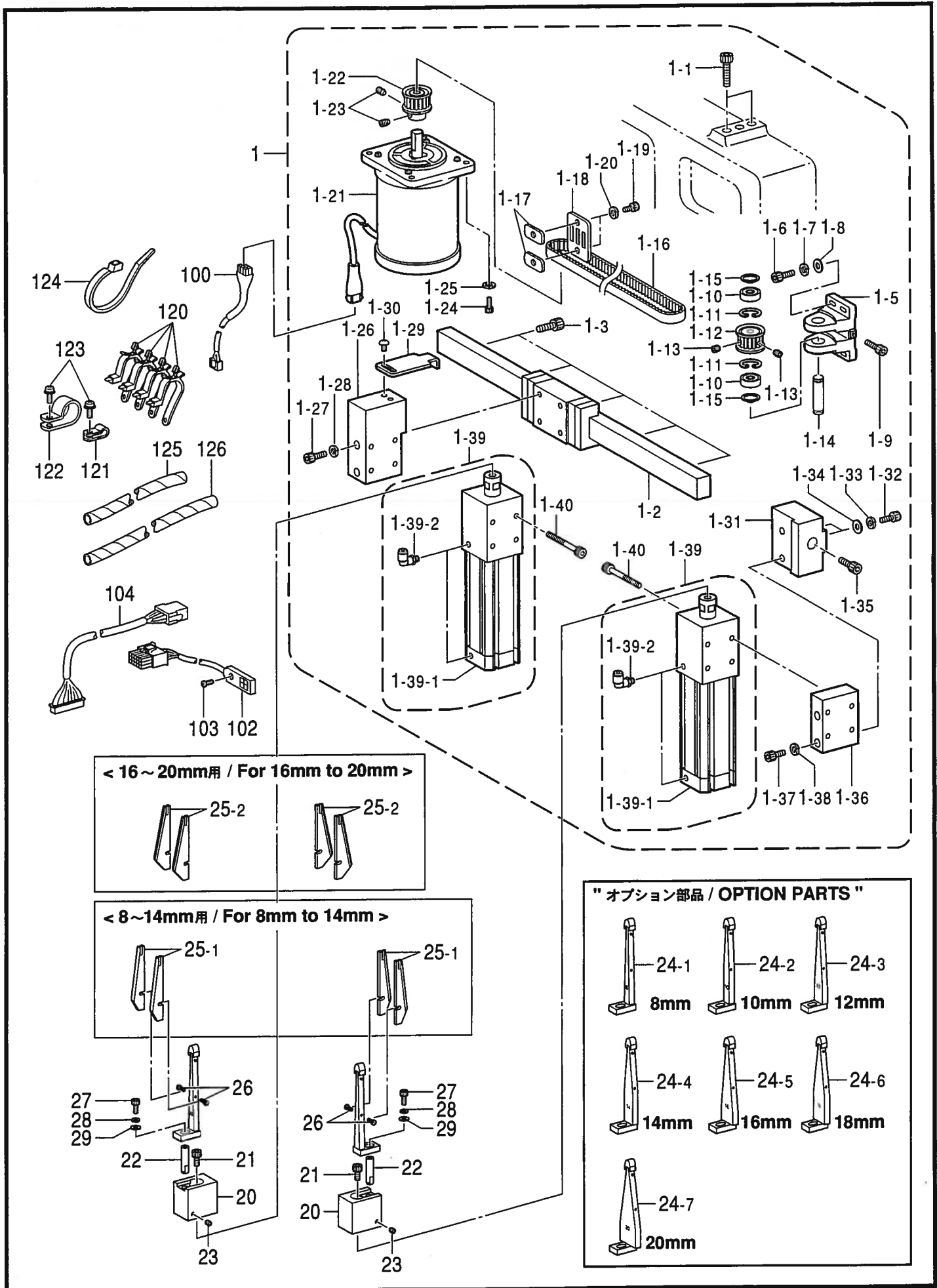



## AC.コーナーメス関係 / Corner knife mechanism

| REF.NO | CODE      | Q'TY | ヒンメイ           | NAME OF PARTS                 | RM |
|--------|-----------|------|----------------|-------------------------------|----|
| 26     | 111140002 | 4    | シメネジ 2.38      | SCREW, SM2.38                 |    |
| 27     | 018401236 | 2    | アナボルト4X12      | BOLT, SOCKET M4X12            |    |
| 28     | 028040246 | 2    | ハネサカネ2-4       | WASHER, SPRING 2-4            |    |
| 29     | 025040236 | 2    | ヒラサカネチユ4       | WASHER, PLAIN M 4             |    |
| 100    | S52453000 | 1    | コーナーメスパワーハーネス  | C/K POWER HARNESS, M/PCB-MT   |    |
| 102    | S52986000 | 1    | コーナーメス位置センサL   | HOME POSITION SENSOR, C/K     |    |
| 103    | 062301006 | 1    | ナハコ3X10        | SCREW, PAN M3X10              |    |
| 104    | S52724000 | 1    | コーナーメスセンサハーネス  | SENSOR HARNESS, C/K           |    |
| 120    | S39821000 | 4    | コードクランプ 19P7   | CORD CLAMP, 19P7              |    |
| 121    | 625010000 | 1    | ナイロンクランプ NK-2N | CORD HOLDER, NK-2N            |    |
| 122    | 552907000 | 1    | コードホルダ #10     | CORD HOLDER, 10N              |    |
| 123    | 0A5401005 | 2    | ナハサクミ4X10DB    | SCREW, PAN (S/P WASHER) M4X10 |    |
| 124    | S04557000 | 1    | バンドPLT1M       | BAND, PLT1M                   |    |
| 125    | S55302000 | 1    | スパイラル400L      | SPIRAL, L=400                 |    |
| 126    | S55305000 | 1    | スパイラル220L      | SPIRAL, L=220                 |    |

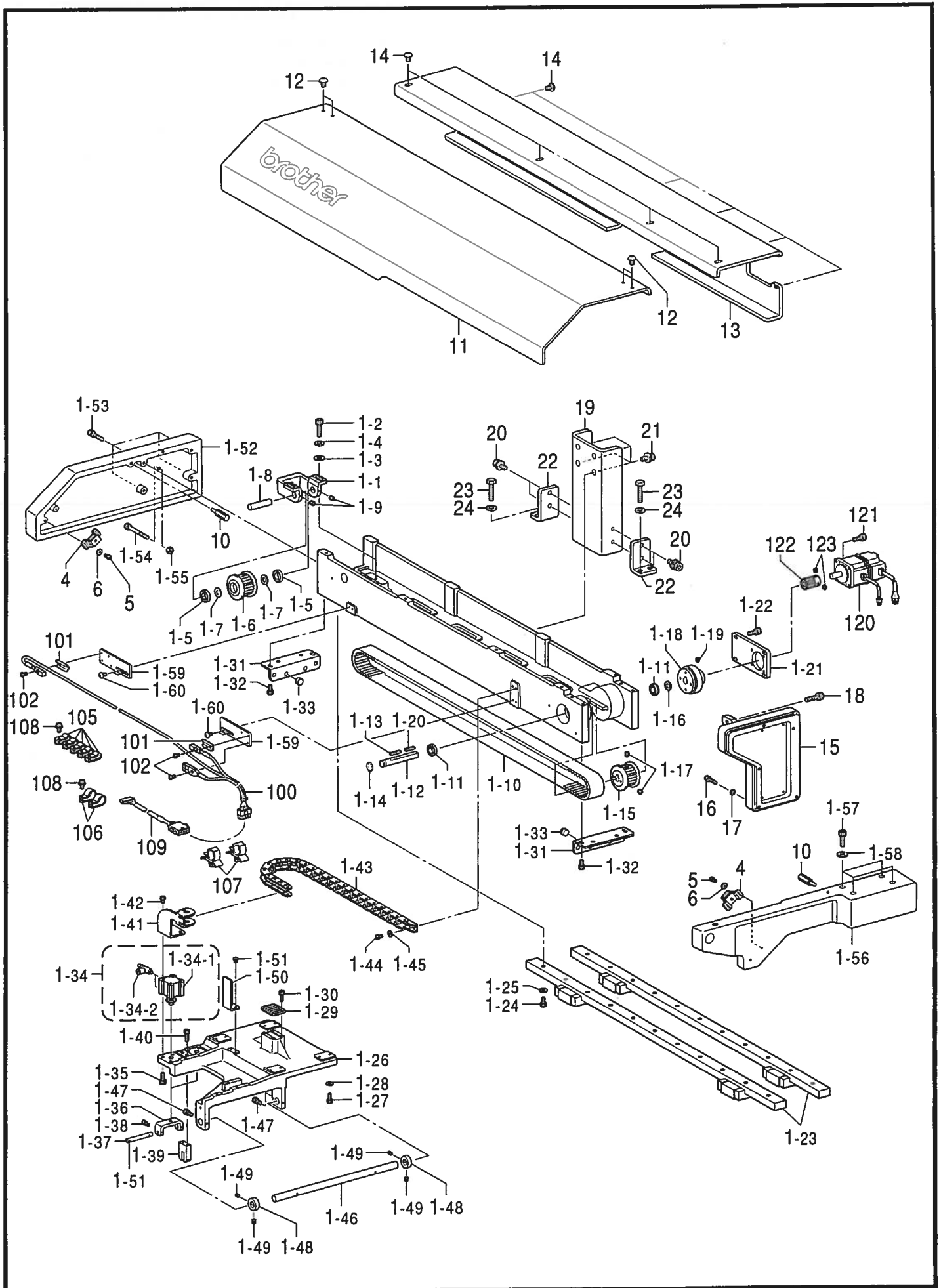

## AD.送り装置関係 / Feed device mechanism

| REF.NO | CODE      | Q'TY | ヒンメイ         | NAME OF PARTS                | RM |
|--------|-----------|------|--------------|------------------------------|----|
| 1-1    | S53742001 | 1    | フーリササI       | PULLEY SETTING BRACKET       |    |
| 1-2    | 018062022 | 2    | アナホルト6X20    | BOLT, SOCKET M6X20           |    |
| 1-3    | 025060236 | 2    | ヒラサカネチユウ6    | WASHER, PLAIN M 6            |    |
| 1-4    | 028060246 | 2    | ハネサカネ2-6     | WASHER, SPRING 2-6           |    |
| 1-5    | S12078000 | 2    | フカミノタマシクウケ2  | BALL BEARING, 2 DEEP GROOVE  |    |
| 1-6    | S53785001 | 1    | フーリーA        | TIMING PULLEY, A             |    |
| 1-7    | S12079000 | 2    | カラ-2         | COLLAR, 2                    |    |
| 1-8    | S12076000 | 1    | フーリーシクD      | PULLEY SHAFT, D              |    |
| 1-9    | 012500536 | 2    | アナヒラ5X5      | SET SCREW, SOCKET (FT) M5X5  |    |
| 1-10   | S53743000 | 1    | タイミングベルト     | TIMING BELT                  |    |
| 1-11   | 076002450 | 2    | タマシクウケ6002DD | BALL BEARING, 6002DD         |    |
| 1-12   | S53744001 | 1    | フーリーシク       | PULLEY SHAFT                 |    |
| 1-13   | S12067000 | 1    | キー           | KEY, 5X35                    |    |
| 1-14   | 048150142 | 1    | トメワシクヨウC15   | RETAINING RING, EXTERNAL C15 |    |
| 1-15   | S53787001 | 1    | フーリーB        | TIMING PULLEY, B             |    |
| 1-16   | 116920001 | 1    | オクリシクスラストリング | RING, THRUST                 |    |
| 1-17   | 012060636 | 2    | アナヒラ6X6      | SET SCREW, SOCKET (FT) M6X6  |    |
| 1-18   | S53745000 | 1    | ナイロンギア66     | SPUR GEAR, 66 ;PA            |    |
| 1-19   | 012500536 | 1    | アナヒラ5X5      | SET SCREW, SOCKET (FT) M5X5  |    |
| 1-20   | S53747000 | 1    | キー5X30       | KEY, 5X30                    |    |
| 1-21   | S53748001 | 1    | モータリツケイタ     | MOTOR SETTING PLATE          |    |
| 1-22   | 018501236 | 4    | アナホルト5X12    | BOLT, SOCKET M5X12           |    |
| 1-23   | S53749000 | 2    | リニアガイド15X700 | LINEAR GUIDE, 15X700         |    |
| 1-24   | 018401436 | 14   | アナホルト4X14    | BOLT, SOCKET M4X14           |    |
| 1-25   | 028040246 | 14   | ハネサカネ2-4     | WASHER, SPRING 2-4           |    |
| 1-26   | S53750001 | 1    | オオオサエオクリタイ   | FEED BRACKET                 |    |
| 1-27   | 018401636 | 8    | アナホルト4X16    | BOLT, SOCKET M4X16           |    |
| 1-28   | 028040246 | 8    | ハネサカネ2-4     | WASHER, SPRING 2-4           |    |
| 1-29   | S53751001 | 1    | ベルトホルダ       | BELT HOLDER                  |    |
| 1-30   | 018501636 | 4    | アナホルト5X16    | BOLT, SOCKET M5X16           |    |
| 1-31   | S53752001 | 2    | リミットプレート     | LIMIT PLATE                  |    |
| 1-32   | 018501236 | 4    | アナホルト5X12    | BOLT, SOCKET M5X12           |    |
| 1-33   | 104821001 | 4    | ゴムセン10.5     | RUBBER CAP, 10.5             |    |
| 1-34   | S53753000 | 2    | シリンダ-クミ      | CYLINDER ASSY                |    |
| 1-34-1 | S53754000 | 2    | エアシリンダ25X15  | AIR CYLINDER, 25X12          |    |
| 1-34-2 | S53786000 | 4    | スピードコントローラ   | SPEED CONTROLLER             |    |
| 1-35   | 018061422 | 8    | アナホルト6X14    | BOLT, SOCKET M6X14           |    |
| 1-36   | S53756001 | 2    | シリンダ-ツギテ     | CYLINDER SUPPORT             |    |
| 1-37   | S53757001 | 2    | シテンシク        | FULCRUM SHAFT                |    |
| 1-38   | 018301036 | 4    | アナホルト3X10    | BOLT, SOCKET M3X10           |    |
| 1-39   | S53758001 | 1    | シリンダ-ガイド     | CYLINDER GUIDE               |    |
| 1-40   | 018502036 | 2    | アナホルト5X20    | BOLT, SOCKET M5X20           |    |
| 1-41   | S53759001 | 1    | コードササエイタ     | CORD SUPPORT BRACKET         |    |
| 1-42   | 062061012 | 2    | ナベコ6X10      | SCREW, PAN M6X10             |    |
| 1-43   | S53760000 | 1    | ランナ-フレックス    | RUNER FLEX                   |    |
| 1-44   | 002501003 | 2    | ナベコ5X10      | SCREW, PAN M5X10             |    |
| 1-45   | 025050236 | 2    | ヒラサカネチユウ5    | WASHER, PLAIN M 5            |    |
| 1-46   | S56861001 | 1    | オオオサエカイテンシク  | SHAFT                        |    |
| 1-47   | 018500836 | 2    | アナホルト5X8     | BOLT, SOCKET M5X8            |    |
| 1-48   | S56862001 | 6    | セットカラ-       | SET SCREW COLLAR             |    |
| 1-49   | 012500536 | 12   | アナヒラ5X5      | SET SCREW, SOCKET (FT) M5X5  |    |
| 1-50   | S53773001 | 1    | オクリダイセンサ-ドグ  | SENSOR DOG, F/B              |    |
| 1-51   | 008400604 | 2    | ナベコ4X6       | SCREW, TRUSS M4X6            |    |
| 1-52   | S53774001 | 1    | オクリダイカバ-L    | FEED BRACKET COVER, L        |    |
| 1-53   | 018501636 | 4    | アナホルト5X16    | BOLT, SOCKET M5X16           |    |
| 1-54   | S29742001 | 1    | アナホルト5X50    | BOLT, SOCKET M5X50           |    |
| 1-55   | 021500216 | 1    | 2シユナツト5      | NUT, 2 M5                    |    |
| 1-56   | S53775001 | 1    | オクリダイカバ-R    | FEED BRACKET COVER, R        |    |
| 1-57   | 018061636 | 4    | アナホルト6X16    | BOLT, SOCKET M6X16           |    |
| 1-58   | 026060136 | 4    | ヒラサカネコカタ6    | WASHER, PLAIN S 6            |    |
| 1-59   | S53783001 | 2    | センサ-トリツケプレート | SENSOR SETTING PLATE         |    |

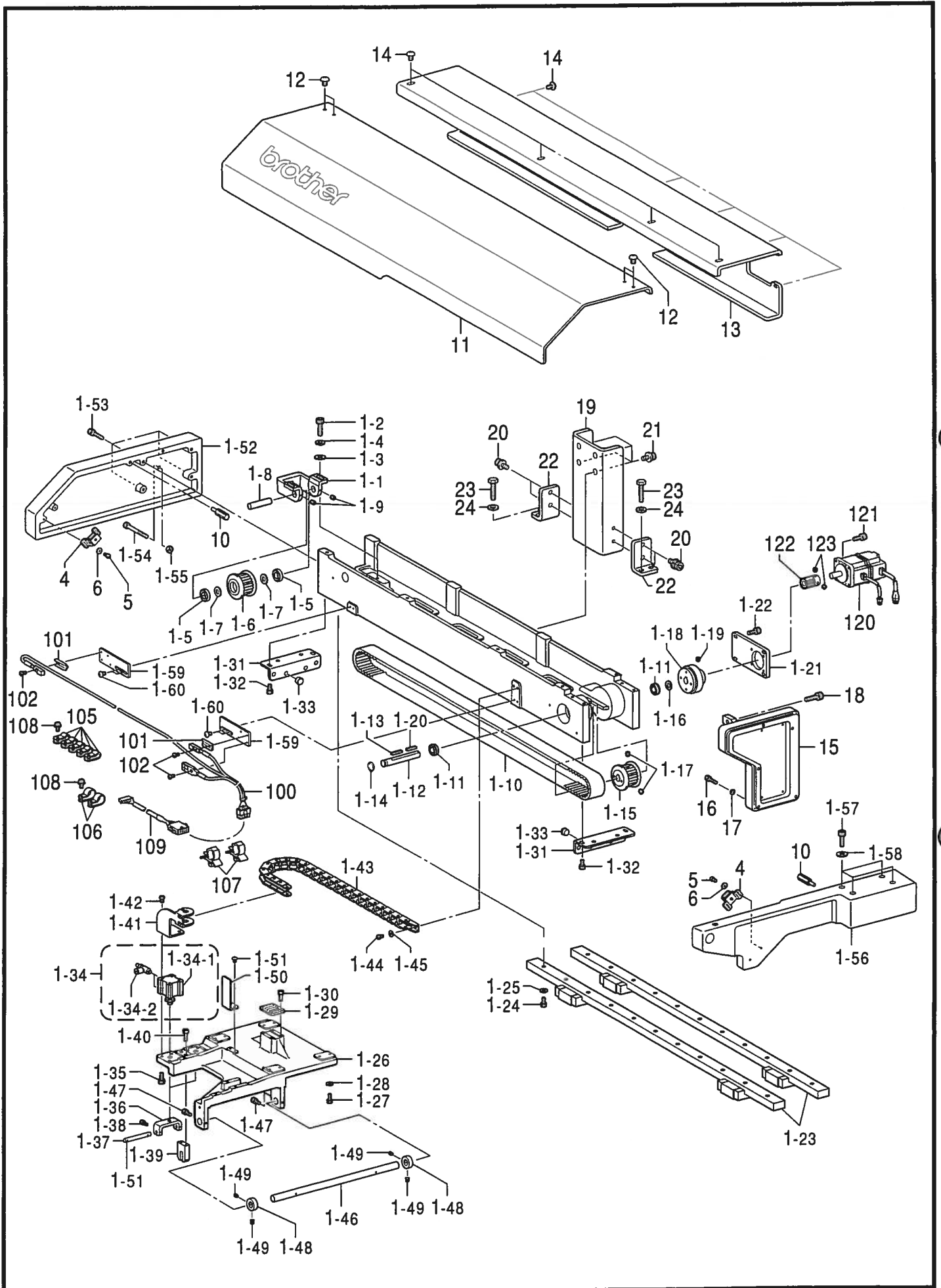

## AD.送り装置関係 / Feed device mechanism

| REF.NO | CODE      | Q'TY | ヒンメイ           | NAME OF PARTS                  | RM |
|--------|-----------|------|----------------|--------------------------------|----|
| 1-60   | 008400604 | 4    | +トラスコ4X6       | SCREW, TRUSS M4X6              |    |
| 4      | S53776000 | 2    | マグネットキャッチ      | MAGNETIC CATCH                 |    |
| 5      | 002300603 | 4    | +ナベコ3X6        | SCREW, PAN M3X6                |    |
| 6      | 025030236 | 4    | ヒラサカネチユウ3      | WASHER, PLAIN M 3              |    |
| 10     | S53777001 | 2    | オクリカハ-ヒンジ      | HINGE                          |    |
| 11     | S56870001 | 1    | オクリカハ1615カハ-   | COVER 615                      |    |
| 12     | 008400604 | 4    | +トラスコ4X6       | SCREW, TRUSS M4X6              |    |
| 13     | S53779001 | 1    | オクリウシロカハ-      | REAR COVER                     |    |
| 14     | 008400604 | 9    | +トラスコ4X6       | SCREW, TRUSS M4X6              |    |
| 15     | S53780001 | 1    | オクリタイサIF       | FEED BRACKET SUPPORT, F        |    |
| 16     | 018502036 | 5    | アナホルト5X20      | BOLT, SOCKET M5X20             |    |
| 17     | 028050246 | 5    | ハネサカネ2-5       | WASHER, SPRING 2-5             |    |
| 18     | 018062036 | 4    | アナホルト6X20      | BOLT, SOCKET M6X20             |    |
| 19     | S53781001 | 1    | オクリタイサI        | FEED BRACKET SUPPORT           |    |
| 20     | S55488001 | 4    | アナホルトサクミ8X16   | BOLT, SOCKET (S/P WASHER)M8X16 |    |
| 21     | S42445001 | 4    | アナホルトサクミ8X25   | BOLT, SOCKET (S/P WASHER)M8X25 |    |
| 22     | S53782001 | 2    | アングル           | ANGLE                          |    |
| 23     | 017082016 | 4    | ホルト8X20        | BOLT, M8X20                    |    |
| 24     | 028080246 | 4    | ハネサカネ2-8       | WASHER, SPRING 2-8             |    |
| 100    | S52452000 | 1    | エリアセンサ         | AREA SENSOR                    |    |
| 101    | S53917000 | 2    | センサカクMS-GL8    | SENSOR BRACKET, MS-GL8         |    |
| 102    | 062300806 | 3    | ナベコ3X8         | SCREW, PAN M3X8                |    |
| 105    | 625010000 | 5    | ナイロンクランプ°NK-2N | CORD HOLDER, NK-2N             |    |
| 106    | 552907000 | 2    | コードホルタ°#10     | CORD HOLDER, 10N               |    |
| 107    | S04505000 | 2    | CKスクランプ°13-H   | CORD CLAMP, 13-H               |    |
| 108    | 0A5401005 | 7    | +ナベサクミ4X10DB   | SCREW, PAN (S/P WASHER) M4X10  |    |
| 109    | S52451000 | 1    | エリアセンサハーネス     | AREA SENSOR HARNESS            |    |
| 120    | S52974000 | 1    | サーボモータ200Wクミ   | SERVO MOTOR, 200W ASSY         |    |
| 121    | 018501236 | 4    | アナホルト5X12      | BOLT, SOCKET M5X12             |    |
| 122    | S53784000 | 1    | ハグルマ20         | SPUR GEAR, 20                  |    |
| 123    | 012060636 | 2    | アナヒラ6X6        | SET SCREW, SOCKET (FT) M6X6    |    |

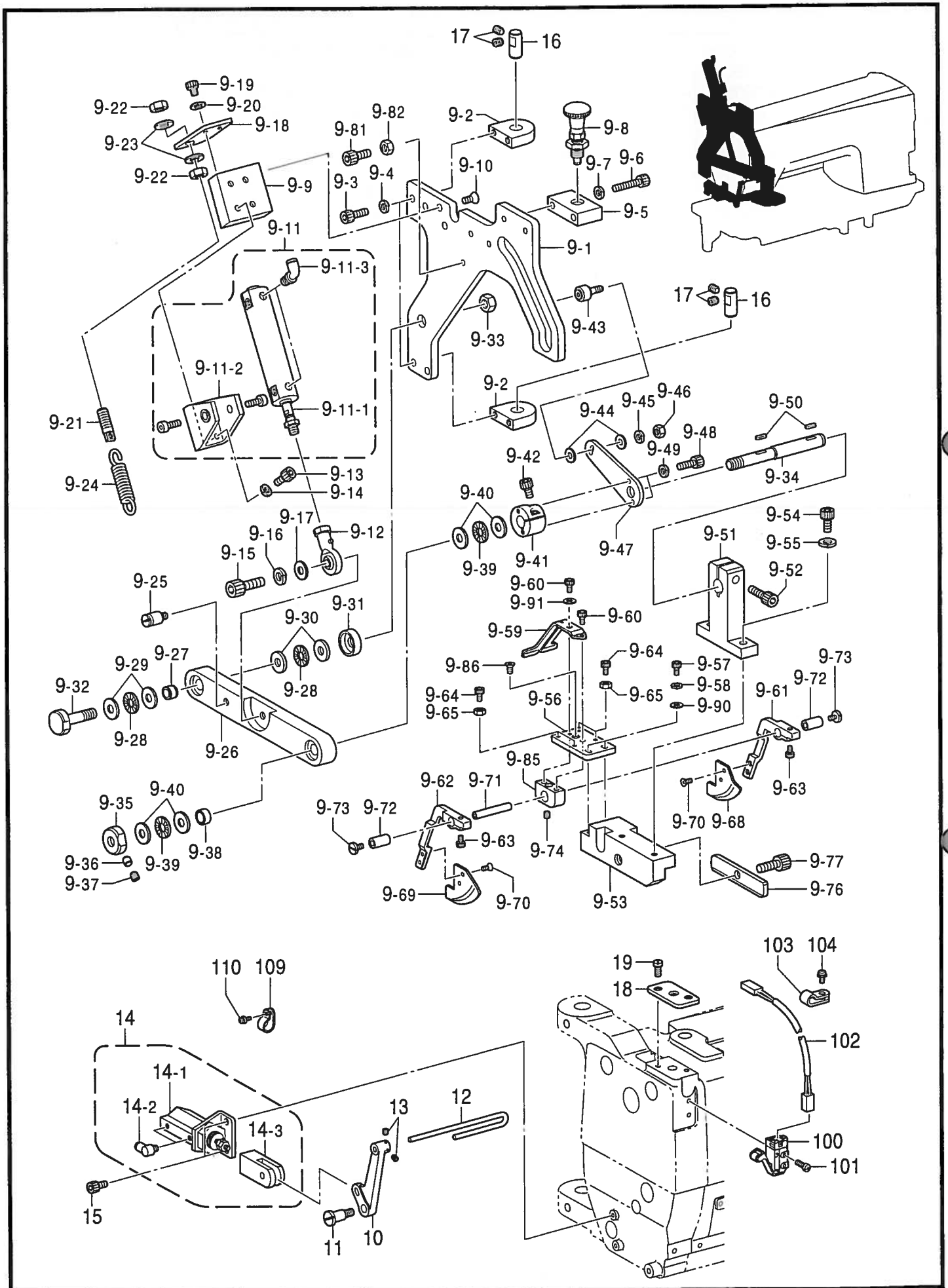

## AE.バインダー関係 / Binder mechanism

| REF.NO | CODE      | Q'TY | ヒンメイ         | NAME OF PARTS               | RM |
|--------|-----------|------|--------------|-----------------------------|----|
| 9-1    | S53792001 | 1    | メインプレート      | MAIN PLATE                  |    |
| 9-2    | S53793001 | 2    | シテンプレート      | PLATE                       |    |
| 9-3    | 018501636 | 4    | アナホルト5X16    | BOLT, SOCKET M5X16          |    |
| 9-4    | 028050246 | 4    | ハネサガネ2-5     | WASHER, SPRING 2-5          |    |
| 9-5    | S53794001 | 1    | インデックスプレート   | INDEX PLATE                 |    |
| 9-6    | 018503036 | 2    | アナホルト5X30    | BOLT, SOCKET M5X30          |    |
| 9-7    | 028050246 | 2    | ハネサガネ2-5     | WASHER, SPRING 2-5          |    |
| 9-8    | S17533000 | 1    | プランジヤ        | PLUNGER                     |    |
| 9-9    | S53795001 | 1    | シリンダプレート     | CYLINDER PLATE              |    |
| 9-10   | 004501003 | 2    | +サラコ5X10     | SCREW, FLAT M5X10           |    |
| 9-11   | S57937000 | 1    | シリンダクミ       | CYLINDER ASSY               |    |
| 9-11-1 | S57938000 | 1    | エアシリンダ 20X50 | AIR CYLINDER, 20X50         |    |
| 9-11-2 | S53820000 | 1    | ヨウトウケカナク     | SUPPORT BRACKET             |    |
| 9-11-3 | S53819000 | 2    | エルボ 04-1/8   | ELBOW, 04-1/8               |    |
| 9-12   | S08352000 | 1    | ロッドエンド       | ROD END                     |    |
| 9-13   | 018501036 | 4    | アナホルト5X10    | BOLT, SOCKET M5X10          |    |
| 9-14   | 028050246 | 4    | ハネサガネ2-5     | WASHER, SPRING 2-5          |    |
| 9-15   | 018082536 | 1    | アナホルト8X25    | BOLT, SOCKET M8X25          |    |
| 9-16   | 028080246 | 1    | ハネサガネ2-8     | WASHER, SPRING 2-8          |    |
| 9-17   | 025080236 | 2    | ヒラサガネチユウ8    | WASHER, PLAIN M 8           |    |
| 9-18   | S53798001 | 1    | ハネカケプレート     | SPRING HOOK PLATE           |    |
| 9-19   | 018401036 | 2    | アナホルト4X10    | BOLT, SOCKET M4X10          |    |
| 9-20   | 028040246 | 2    | ハネサガネ2-4     | WASHER, SPRING 2-4          |    |
| 9-21   | S53799000 | 1    | ハネヨウホスト      | SPRING HOOK POST            |    |
| 9-22   | 021080206 | 2    | 2シユナツト8      | NUT, 2 M8                   |    |
| 9-23   | 025080236 | 2    | ヒラサガネチユウ8    | WASHER, PLAIN M 8           |    |
| 9-24   | S53800001 | 1    | シヨウキモトシハネ    | SPRING, EXTENSION 13.1X71.1 |    |
| 9-25   | S53640001 | 1    | ハネカケ         | SPRING HOOK                 |    |
| 9-26   | S53801001 | 1    | アーム          | ARM                         |    |
| 9-27   | S08332000 | 1    | ドライバアリンク     | BUSH, BM1212FB              |    |
| 9-28   | S08238000 | 2    | スラストバアリンク    | BEARING, THRUST             |    |
| 9-29   | S08239000 | 2    | スラストワツシヤ     | WASHER, THRUST              |    |
| 9-30   | S08240000 | 2    | スラストワツシヤ     | WASHER, THRUST              |    |
| 9-31   | S08342001 | 1    | スラストバアリンクカバー | THRUST BEARING COVER        |    |
| 9-32   | S53802001 | 1    | シテンシク        | FULCRUM SHAFT               |    |
| 9-33   | 021120304 | 1    | ナツト3シユ12     | NUT, 3 M12                  |    |
| 9-34   | S53803001 | 1    | シヨウキシテンシク    | FULCRUM SHAFT, BINDER       |    |
| 9-35   | S08338001 | 1    | ヨアツナツト       | PRE-LOAD NUT                |    |
| 9-36   | S08339001 | 1    | ユルミドメ        | LOOSENESS STOPPER           |    |
| 9-37   | 012060636 | 1    | アナヒラ6X6      | SET SCREW, SOCKET (FT) M6X6 |    |
| 9-38   | S31921000 | 1    | ドライバアリンク     | BUSH, BM1208FB              |    |
| 9-39   | S08238000 | 2    | スラストバアリンク    | BEARING, THRUST             |    |
| 9-40   | S08239000 | 4    | スラストワツシヤ     | WASHER, THRUST              |    |
| 9-41   | S53804001 | 1    | セットカラ        | SET SCREW COLLAR            |    |
| 9-42   | 018501036 | 1    | アナホルト5X10    | BOLT, SOCKET M5X10          |    |
| 9-43   | S58594000 | 1    | カムフォロアCR8BUU | CAM FOLLOWER                |    |
| 9-44   | 025050236 | 2    | ヒラサガネチユウ5    | WASHER, PLAIN M 5           |    |
| 9-45   | 028050246 | 1    | ハネサガネ2-5     | WASHER, SPRING 2-5          |    |
| 9-46   | 021500216 | 1    | 2シユナツト5      | NUT, 2 M5                   |    |
| 9-47   | S53805001 | 1    | カムフォロアトリツケイタ | SETTING PLATE               |    |
| 9-48   | 018501636 | 2    | アナホルト5X16    | BOLT, SOCKET M5X16          |    |
| 9-49   | 028050246 | 2    | ハネサガネ2-5     | WASHER, SPRING 2-5          |    |
| 9-50   | S08280000 | 2    | キ-4X4X16     | KEY, 4X4X16                 |    |
| 9-51   | S53806001 | 1    | シヨウキトリツケイタA  | BINDER SETTING PLATE, A     |    |
| 9-52   | 018062036 | 1    | アナホルト6X20    | BOLT, SOCKET M6X20          |    |
| 9-53   | S59046001 | 1    | シヨウキトリツケイタB  | BINDER SETTING PLATE, B     |    |
| 9-54   | 018501636 | 2    | アナホルト5X16    | BOLT, SOCKET M5X16          |    |
| 9-55   | 028050246 | 2    | ハネサガネ2-5     | WASHER, SPRING 2-5          |    |
| 9-56   | S59048001 | 1    | イタハネダイF      | PLATE SPRING BASE, F        |    |
| 9-57   | 018301236 | 2    | アナホルト3X12    | BOLT, SOCKET M3X12          |    |
| 9-58   | 028030246 | 2    | ハネサガネ2-3     | WASHER, SPRING 2-3          |    |

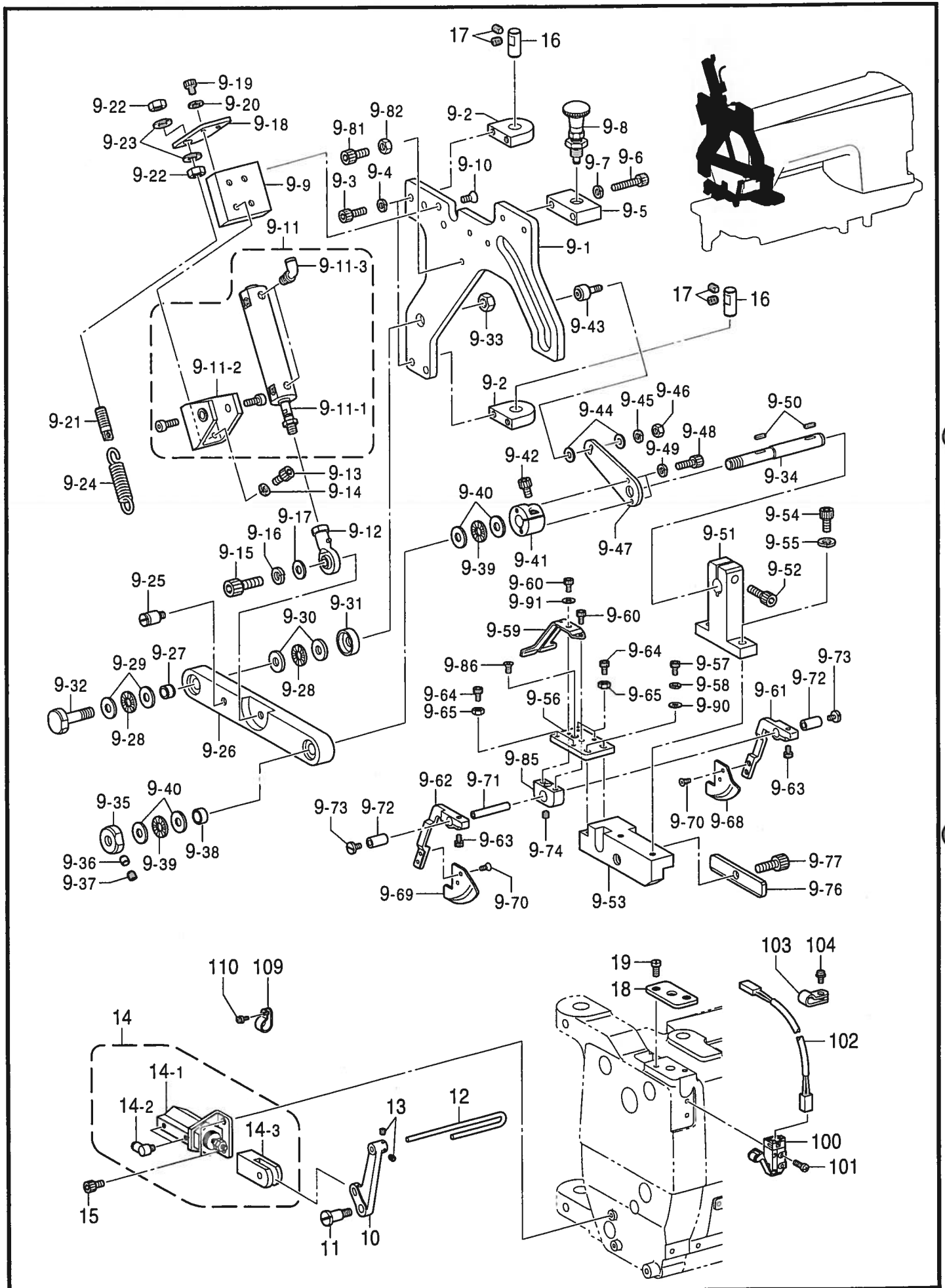



## AE.バインダー関係 / Binder mechanism

| REF.NO | CODE      | Q'TY | ヒンメイ           | NAME OF PARTS                | RM |
|--------|-----------|------|----------------|------------------------------|----|
| 9-59   | S59035000 | 1    | イタバネ           | SPRING, PLATE                |    |
| 9-60   | 018301236 | 2    | アナホルト3X12      | BOLT, SOCKET M3X12           |    |
| 9-61   | S59044001 | 1    | キシカイトア-MR      | CLOTH GUIDE ARM, R           |    |
| 9-62   | S59043001 | 1    | キシカイトア-L       | CLOTH GUIDE ARM, L           |    |
| 9-63   | 018300836 | 2    | アナホルト3X8       | BOLT, SOCKET M3X8            |    |
| 9-64   | 018301236 | 4    | アナホルト3X12      | BOLT, SOCKET M3X12           |    |
| 9-65   | 021300303 | 4    | NUT, 3 M       | NUT, 3 M3                    |    |
| 9-68   | S59034000 | 1    | キシカイトR         | CLOTH GUIDE, R               |    |
| 9-69   | S59033000 | 1    | キシカイトL         | CLOTH GUIDE, L               |    |
| 9-70   | S58692001 | 4    | +サラコ2X3        | SCREW, FLAT M2X3             |    |
| 9-71   | S21008001 | 1    | キシカイトシテンジク     | FULCRUM SHAFT, C/GUIDE       |    |
| 9-72   | S21009001 | 2    | キシカイトヨウスリフ     | SLEEVE, C/GUIDE              |    |
| 9-73   | S30014001 | 2    | フタネジ M3        | SCREW, M3                    |    |
| 9-74   | 012400436 | 1    | アナヒラ4X4        | SET SCREW, SOCKET (FT) M4X4  |    |
| 9-77   | 018082036 | 1    | アナホルト8X20      | BOLT, SOCKET M8X20           |    |
| 9-81   | 018061436 | 1    | アナホルト6X14      | BOLT, SOCKET M6X14           |    |
| 9-82   | 021060206 | 1    | 2シユナツト6        | NUT, 2 M6                    |    |
| 9-85   | S59047001 | 1    | シヨウキトリツケイタC    | BINDER SETTING PLATE, C      |    |
| 9-86   | 004301016 | 2    | +サラコ3X10       | SCREW, FLAT M3X10            |    |
| 9-90   | 025030236 | 2    | ヒラサガネチユウ3      | WASHER, PLAIN M 3            |    |
| 9-91   | 025030236 | 1    | ヒラサガネチユウ3      | WASHER, PLAIN M 3            |    |
| 10     | S14703001 | 1    | イトクリタシウテ       | THREAD TAKE-UP ARM           |    |
| 11     | 141598001 | 1    | タンネジ 4.76      | SHOULDER SCREW, SM4.76       |    |
| 12     | S53815001 | 1    | イトクリタシ         | CURVED WIRE                  |    |
| 13     | 012300336 | 2    | アナヒラ3X3        | SET SCREW, SOCKET (FT) M3X3  |    |
| 14     | S53816100 | 1    | シリンダークミ        | CYLINDER ASSY                |    |
| 14-1   | S53817100 | 1    | エアシリンダ 10X5    | AIR CYLINDER 10X5            |    |
| 14-2   | S12150000 | 2    | ホースエルボ M-5HL-4 | TUBE ELBOW, M-5HL-4          |    |
| 14-3   | S39122000 | 1    | ナツクルジョイントM4    | KNUCKLE JOINT, M4            |    |
| 15     | 018400836 | 2    | アナホルト4X8       | BOLT, SOCKET M4X8            |    |
| 16     | S53818001 | 2    | シテンピン          | FULCRUM PIN                  |    |
| 17     | 012500536 | 4    | アナヒラ5X5        | SET SCREW, SOCKET (FT) M5X5  |    |
| 18     | S53686001 | 1    | イチキメイタ         | POSITIONING PLATE            |    |
| 19     | S20355002 | 2    | シメネジ3X8.5      | SCREW, M3X8.5                |    |
| 100    | S52759000 | 1    | SW-D3M-01K2-3  | MICRO SWITCH, D3M-01K2-3     |    |
| 101    | 002021205 | 2    | +ナヘコ2X12       | SCREW, PAN M2X12             |    |
| 102    | S52468000 | 1    | メンイタSWハネス      | SWITCH HARNESS, SW-M/PCB     |    |
| 103    | S10243000 | 1    | ナイロンクランプNK-3N  | CORD HOLDER, ;NK-3N          |    |
| 104    | 0A5400805 | 1    | +ナヘサクミ4X8DB    | SCREW, PAN (S/P WASHER) M4X8 |    |
| 109    | 625010000 | 1    | ナイロンクランプNK-2N  | CORD HOLDER, NK-2N           |    |
| 110    | 0A4300605 | 1    | +ナヘサクミ3X6DA    | SCREW, PAN (S/P WASHER) M3X6 |    |

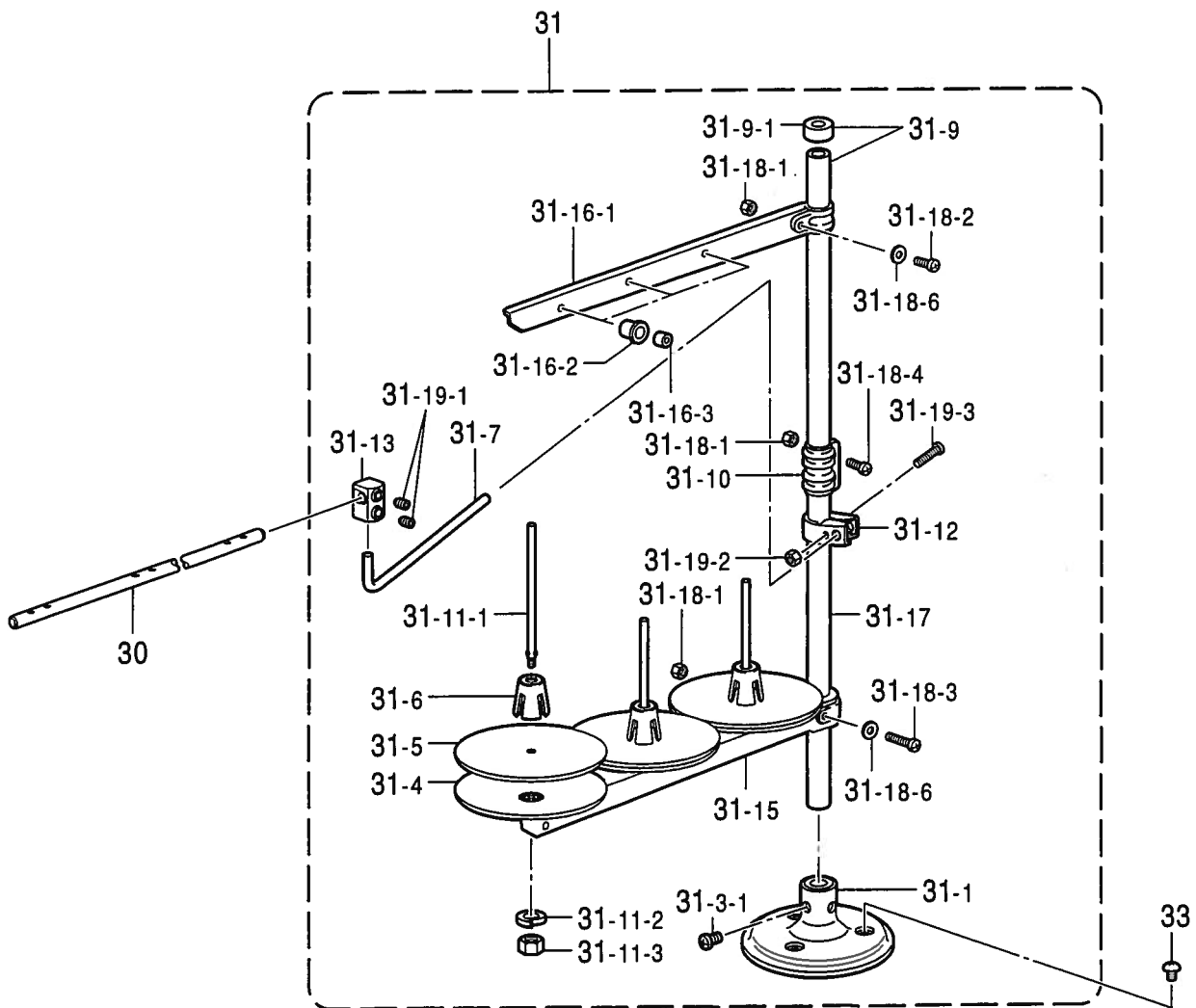
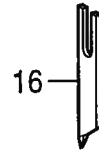
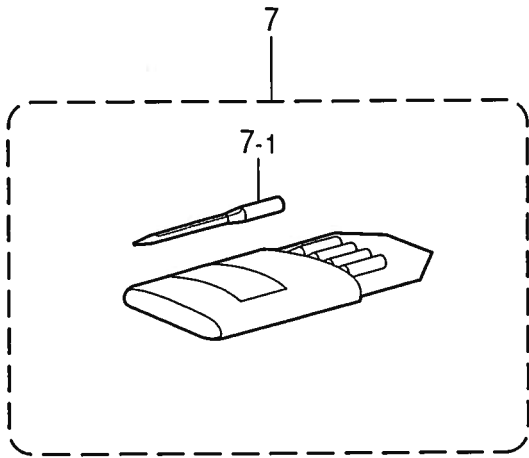

Z1.付属品関係 / Accessories

\* 付属品の明細は変更することがあります / The details of included accessories are subject to change.

| REF.NO  | CODE      | Q'TY | ヒンメイ                    | NAME OF PARTS                 | RM |
|---------|-----------|------|-------------------------|-------------------------------|----|
| 7       | 153011416 | 1    | ミシンハリMTX190クミ           | NEEDLE ASSY, MTX190 (#16)     |    |
| 7-1     | 153011016 | 4    | ミシンハリMTX190             | NEEDLE, MTX190 (#16)          |    |
| 8       | S09285051 | 4    | <標準品><br>ホビ`ン           | <Standard parts><br>BOBBIN, 2 |    |
| 16      | S59152001 | 1    | ウ`メ`ス`C                 | UPPER KNIFE, C                |    |
| 30      | S54022001 | 1    | イト`アン`ナイ                | THREAD GUIDE                  |    |
| 31      | S02767409 | 1    | イト`タ`テ`タ`ク`ミ`3`TH`F     | COTTON SATND ASSY, 3THF       |    |
| 31-1    | 150189109 | 1    | フ`ラ`ケ`ツ                 | COTTON STAND BRACKET          |    |
| 31-3-1  | 062060806 | 2    | ナ`ヘ`コ`6`X`8             | SCREW, PAN M6X8               |    |
| 31-4    | S51283001 | 3    | ウ`ケ`サ`ラ                 | SPOOL STAND BASE              |    |
| 31-5    | 150182000 | 3    | ス`プ`-`ル`マ`ツ             | SPOOL MAT                     |    |
| 31-6    | 126863001 | 3    | ス`プ`-`ル`ク`ツ`シ`ヨ`ン       | SPOOL CUSHION                 |    |
| 31-7    | S04109001 | 1    | イト`アン`ナイ`サ`サ`エ`ホ`ウ      | SUPPORT BAR, ;TR-GUIDE        |    |
| 31-9    | S40639001 | 1    | コ`ラ`ム`ハ`イ`ブ`キ`ヤ`ツ`ブ`ツ`キ | COLUMN PIPE W/CAP             |    |
| 31-9-1  | 150174000 | 1    | コ`ラ`ム`キ`ヤ`ツ`ブ`          | COLUMN CAP                    |    |
| 31-10   | 150173003 | 1    | コ`ラ`ム`シ`ヨ`イ`ン`ト         | COLUMN JOINT                  |    |
| 31-11   | S21798001 | 3    | ス`プ`-`ル`ネ`ジ`セ`ツ         | SPOOL & SCREW SET             |    |
| 31-11-1 | 150179002 | 3    | ス`プ`-`ル`シ`ク`B           | SPOOL SHAFT, B                |    |
| 31-11-2 | 028050246 | 3    | ハ`ネ`サ`カ`ネ`2`-`5         | WASHER, SPRING 2-5            |    |
| 31-11-3 | 021500106 | 3    | 1`シ`ユ`ナ`ツ`ト`5           | NUT, 1 M5                     |    |
| 31-12   | 150185009 | 1    | イト`アン`ナイ`ホ`ル`ダ`-        | THREAD GUIDE HOLDER           |    |
| 31-13   | 138843001 | 1    | サ`サ`エ`ホ`ウ`ツ`キ`テ         | JOINT                         |    |
| 31-15   | S02779009 | 1    | ス`プ`-`ル`ホ`ル`ダ`-`3       | SPOOL HOLDER, 3               |    |
| 31-16   | S02788009 | 1    | ス`レ`ツ`ト`ハ`ン`カ`-`ク`ミ`3   | THREAD HANGER ASSY, 3         |    |
| 31-16-1 | S02789009 | 1    | ス`レ`ツ`ト`ハ`ン`カ`-`3       | THREAD HANGER, 3              |    |
| 31-16-2 | 150183000 | 3    | イト`カ`ケ`ハ`ン`カ`-`タ`イ      | THREAD HANGER BASE            |    |
| 31-16-3 | 142990001 | 3    | ス`レ`ツ`ト`ブ`ツ`シ`ユ         | THREAD BUSH                   |    |
| 31-17   | 150172003 | 1    | コ`ラ`ム`ハ`イ`ブ`            | COLUMN PIPE                   |    |
| 31-18   | S40641001 | 1    | ス`プ`-`ル`シ`ク`ネ`ジ`セ`ツ`A   | SPOOL SHAFT & SCREW SET, A    |    |
| 31-18-1 | 021500106 | 4    | 1`シ`ユ`ナ`ツ`ト`5           | NUT, 1 M5                     |    |
| 31-18-2 | 062501406 | 1    | ナ`ヘ`コ`5`X`14            | SCREW, PAN M5X14              |    |
| 31-18-3 | 062503506 | 1    | ナ`ヘ`コ`M`5`X`35          | SCREW, PAN M5X35              |    |
| 31-18-4 | 062501406 | 2    | ナ`ヘ`コ`5`X`14            | SCREW, PAN M5X14              |    |
| 31-18-6 | 026050136 | 2    | ヒ`ラ`ザ`カ`ネ`コ`ガ`タ`5       | WASHER, PLAIN S 5             |    |
| 31-19   | S40643001 | 1    | ホ`ル`ダ`-`ツ`キ`テ`ネ`ジ`セ`ツ   | HOLDER JOINT & SCREW SET      |    |
| 31-19-1 | 014060632 | 2    | ア`ナ`ク`ホ`ミ`6`X`6         | SET SCREW, SOCKET (CP) M6X6   |    |
| 31-19-2 | 021500106 | 1    | 1`シ`ユ`ナ`ツ`ト`5           | NUT, 1 M5                     |    |
| 31-19-3 | 062503506 | 1    | ナ`ヘ`コ`M`5`X`35          | SCREW, PAN M5X35              |    |
| 33      | 008400604 | 3    | +ト`ラ`ス`コ`4`X`6          | SCREW, TRUSS M4X6             |    |

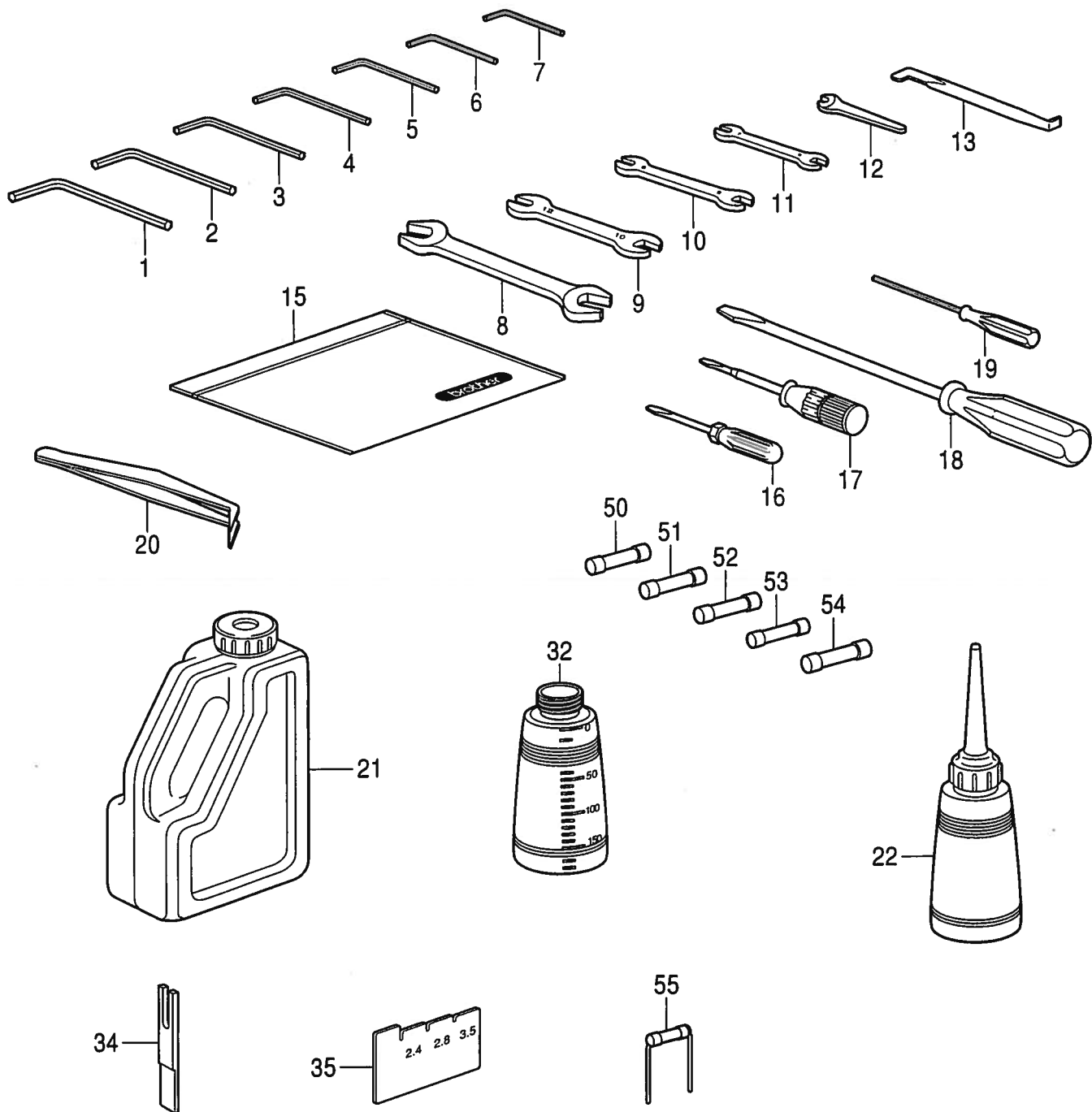

" フラップ仕様 オプション部品  
/ Option parts for flap clamp spec "

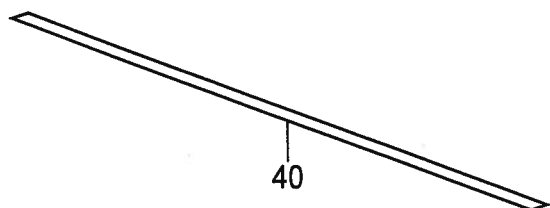

" 下糸検出器 オプション部品  
/ Option parts for lower thread detector "

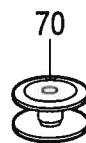

Z2.付属品関係 / Accessories

\* 付属品の明細は変更することがあります / The details of included accessories are subject to change.

| REF.NO | CODE      | QTY | ヒンメイ                                      | NAME OF PARTS  | RM |
|--------|-----------|-----|---|--|----|
| 1      | 115157001 | 1   | 6カクホ <sup>°</sup> ウスハ <sup>°</sup> ナ6     | HEXAGONAL WRENCH, 6                                    |    |
| 2      | 150335001 | 1   | 6カクホ <sup>°</sup> ウスハ <sup>°</sup> ナ5     | HEXAGONAL WRENCH, 5                                    |    |
| 3      | 118064001 | 1   | 6カクホ <sup>°</sup> ウスハ <sup>°</sup> ナ4     | HEXAGONAL WRENCH, 4                                    |    |
| 4      | 142721001 | 1   | 6カクホ <sup>°</sup> ウスハ <sup>°</sup> ナ3     | HEXAGONAL WRENCH, 3                                    |    |
| 5      | 154125001 | 1   | 6カクホ <sup>°</sup> ウスハ <sup>°</sup> ナ2.5   | HEXAGONAL WRENCH, 2.5                                  |    |
| 6      | 142002001 | 1   | 6カクホ <sup>°</sup> ウスハ <sup>°</sup> ナ2     | HEXAGONAL WRENCH, 2                                    |    |
| 7      | S07783001 | 1   | 6カクホ <sup>°</sup> ウスハ <sup>°</sup> ナ1.5   | HEXAGONAL WRENCH, 1.5                                  |    |
| 8      | S14696001 | 1   | スパ <sup>°</sup> ナ11X13                    | SPANNER 11X13  |    |
| 9      | 107780001 | 1   | スパ <sup>°</sup> ナ10X12                    | WRENCH, 10X12  |    |
| 10     | 100887001 | 1   | スパ <sup>°</sup> ナ8X9                      | WRENCH, 8X9  |    |
| 11     | 142205001 | 1   | スパ <sup>°</sup> ナ7X8                      | WRENCH, 7X8  |    |
| 12     | S08132001 | 1   | スパ <sup>°</sup> ナ5.5                      | WRENCH, 5.5  |    |
| 13     | S08170001 | 1   | Zカ <sup>°</sup> タネジ <sup>°</sup> マワシ      | SCREW DRIVER, ;Z-TYPE                                  |    |
| 15     | 122991001 | 1   | フゾク <sup>°</sup> ヒンホ <sup>°</sup> リフクロ    | ACCESSORY BAG  |    |
| 16     | 142443001 | 1   | ネジ <sup>°</sup> マワシ1.9X52                 | SCREW DRIVER, 1.9X52                                   |    |
| 17     | 118837001 | 1   | ネジ <sup>°</sup> マワシ3.4X70                 | SCREW DRIVER, 3.4X70                                   |    |
| 18     | 101572101 | 1   | ネジ <sup>°</sup> マワシ5.5X190                | SCREW DRIVER, 5.5X190                                  |    |
| 19     | S01943001 | 1   | 6カクホ <sup>°</sup> ウネジ <sup>°</sup> マワシ1.6 | SCREW DRIVER, HEX. 1.6                                 |    |
| 20     | 117466000 | 1   | ピンセット                                     | PINCETTE   |    |
| 21     | S55663001 | 1   | オイルタンククミ                                  | OIL TANK ASSY  |    |
| 22     | 114483002 | 1   | ホ <sup>°</sup> リオイラークミ                    | OILER ASSY   |    |
| 32     | 114486002 | 1   | ホ <sup>°</sup> リオイラータイ                    | OILER  |    |
| 34     | S59338001 | 1   | ナカメシ <sup>°</sup> ク                       | JIG, CENTER KNIFE                                      |    |
| 35     | S59350001 | 1   | テ <sup>°</sup> アイケ <sup>°</sup> ージ        | GAUGE, N-BAR HIGHT                                     |    |
| 40     | S57533000 | 2   | <フラップ仕様(OP)の場合><br>ハンシヤシート                | <Option parts for flap clamp spec><br>REFLECTING SHEET |    |
| 50     | 152566000 | 1   | ヒューズ <sup>°</sup> C                       | FUSE, C ;2A/125V                                       |    |
| 51     | 152565000 | 2   | ヒューズ <sup>°</sup> B                       | FUSE, B ;5A/125V                                       |    |
| 52     | S52741000 | 1   | GFUSE6A125V                               | GLASS FUSE, 6A/125V                                    |    |
| 53     | S08030000 | 1   | Gヒューズ <sup>°</sup> 5AFB                   | FUSE, 5A ;FB   |    |
| 54     | 153242000 | 2   | ヒューズ <sup>°</sup> 6A                      | FUSE, 6A   |    |
| 55     | J02727001 | 1   | カンヒューズ <sup>°</sup> 2A250V                | GLASS FUSE, 2A/250V                                    |    |
| 70     | S52490001 | 4   | <下糸検出器(OP)の場合><br>ホ <sup>°</sup> ビン       | <Option parts for lower thread detector><br>BOBBIN     |    |



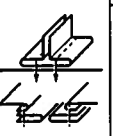
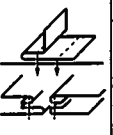



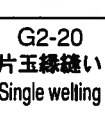
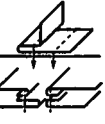
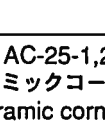



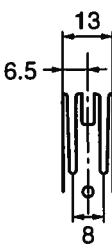
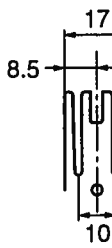

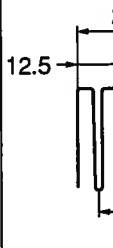





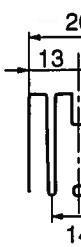

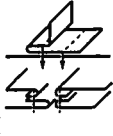

Ga1 . ゲージ部品一覧表 (BAS-6150) / Gauge parts List (BAS-6150)

|   |  | 針幅8mm<br>Needle gauge : 8mm                          | 針幅10mm<br>Needle gauge : 10mm                          | 針幅12mm<br>Needle gauge : 12mm                     | 針幅14mm<br>Needle gauge : 14mm                          | 針幅16mm<br>Needle gauge : 16mm                            |  |
|---|--|--|--|---|--|--|--|
| G1-1-3<br>針抱キ組<br>Needle clamp assy                 |  | S59139-001<br>針抱キ8UP組<br>Needle clamp assy, 8mm      | S59140-001<br>針抱キ10UP組<br>Needle clamp assy, 10mm      | S59141-001<br>針抱キ12UP組<br>Needle clamp assy, 12mm | S59142-001<br>針抱キ14UP組<br>Needle clamp assy, 14mm      | S59143-001<br>針抱キ16UP組<br>Needle clamp assy, 16mm        |  |
| G1-6<br>針板セット<br>Needle plate set                   |  | S52571-001<br>針板8セット<br>Needle plate set, 8          | S52572-001<br>針板10セット<br>Needle plate set, 10          | S52573-001<br>針板12セット<br>Needle plate set, 12     | S52574-001<br>針板14セット<br>Needle plate set, 14          | S52575-001<br>針板16セット<br>Needle plate set, 16            |  |
| G1-3-3<br>針板組<br>Needle plate assy                  |  | S52561-001<br>針板8組<br>Needle plate assy, 8           | S52562-001<br>針板10組<br>Needle plate assy, 10           | S52563-001<br>針板12組<br>Needle plate assy, 12      | S52564-001<br>針板14組<br>Needle plate assy, 14           | S52565-001<br>針板16組<br>Needle plate assy, 16             |  |
| G1-4-3<br>ループガイド<br>Loop guide                      |  | S52536-001<br>ループガイド8<br>Loop guide, 8               | S52537-001<br>ループガイド10<br>Loop guide, 10               | S52538-001<br>ループガイド12<br>Loop guide, 12          | S52539-001<br>ループガイド14<br>Loop guide, 14               | S52540-001<br>ループガイド16<br>Loop guide, 16                 |  |
| G2-1-2<br>滑り板セット<br>Slide plate set                 |  | S53428-000<br>滑り板セット8-12<br>Slide plate set, 8-12    |  |   | S53435-000<br>滑り板セット14-16<br>Slide plate set, 14-16    |  |  |
| G2-1-2-1<br>滑り板組<br>Slide plate assy                |  | S53429-000<br>滑り板組8-12<br>Slide plate assy, 8-12     |  |   | S53436-000<br>滑り板組14-16<br>Slide plate assy, 14-16     |  |  |
| G2-1-2-2<br>滑り板<br>Slide plate                      |  | S53430-001<br>生地滑り板<br>Slide plate                   |  |   | S53430-002<br>生地滑り板<br>Slide plate                     |  |  |
| 定規 / Binder   | G2-10<br>両玉縁縫い<br>Double welting   | 中厚物用<br>Medium-weight materials                      | S59271-000<br>定規組8W-13<br>Binder assy, 8W-13           | S59275-000<br>定規組10W-17<br>Binder assy, 10W-17    | S59279-000<br>定規組12W-21<br>Binder assy, 12W-21         | S59283-000<br>定規組14W-25<br>Binder assy, 14W-25           | S59287-000<br>定規組16W-29<br>Binder assy, 16W-29 |
|   |  |  | 薄物用<br>Light-weight materials                          | S59272-000<br>定規組8W-14<br>Binder assy, 8W-14      | S59276-000<br>定規組10W-18<br>Binder assy, 10W-18         | S59280-000<br>定規組12W-22<br>Binder assy, 12W-22           | S59284-000<br>定規組14W-26<br>Binder assy, 14W-26 |
|   | G2-20<br>片玉縁縫い<br>Single welting   | 中厚物用<br>Medium-weight materials                      |  | S59273-000<br>定規組8S-14<br>Binder assy, 8S-14      | S59277-000<br>定規組10S-18<br>Binder assy, 10S-18         | S59281-000<br>定規組12S-22<br>Binder assy, 12S-22           | S59285-000<br>定規組14S-26<br>Binder assy, 14S-26 |
|   |  |  | 薄物用<br>Light-weight materials                          | S59274-000<br>定規組8S-15<br>Binder assy, 8S-15      | S59278-000<br>定規組10S-19<br>Binder assy, 10S-19         | S59282-000<br>定規組12S-23<br>Binder assy, 12S-23           | S59286-000<br>定規組14S-27<br>Binder assy, 14S-27 |
| AC-25-1,25-2<br>セラミックコーナーメス<br>Ceramic corner knife |  | S14050-001<br>セラミックコーナーメスS<br>Ceramic corner knife,S |  |   |  | S14051-001<br>セラミック<br>コーナーメスL<br>Ceramic corner knife,L |  |
| AC-24<br>メスダイ組<br>Knife base assy                   |  | S11521-001<br>メスダイ8組<br>Knife base assy, 8           | S11522-001<br>メスダイ10組<br>Knife base assy, 10           | S11523-001<br>メスダイ12組<br>Knife base assy, 12      | S11524-001<br>メスダイ14組<br>Knife base assy, 14           | S11525-001<br>メスダイ16組<br>Knife base assy, 16             |  |
| L2-2-2, 2-3<br>固定刃<br>Fixed knife                   |  | S53521-001<br>固定刃8<br>Fixed knife, 8                 | S53494-001<br>固定刃10-12<br>Fixed knife, 10-12           |   | S53495-001<br>固定刃14-16<br>Fixed knife, 14-16           |  |  |
| L2-3-2, 3-3<br>上糸メス<br>N/Thread knife assy          |  | S53522-101<br>上糸メス8組<br>N/Thread knife assy, 8       | S53498-001<br>上糸メス10-12組<br>N/Thread knife assy, 10-12 |   | S53501-101<br>上糸メス14-16組<br>N/Thread knife assy, 14-16 |  |  |
| L2-4-2, 4-3<br>糸保持板<br>Thread holding plate         |  | S53523-001<br>糸保持板8<br>Thread holding plate, 8       | S53507-001<br>糸保持板10-12<br>Thread holding plate, 10-12 |   | S53508-001<br>糸保持板14-16<br>Thread holding plate, 14-16 |  |  |

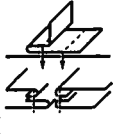
Ga1 . ゲージ部品一覧表 (BAS-6150) / Gauge parts List (BAS-6150)

|   |   | 針幅18mm<br>Needle gauge : 18mm                          | 針幅20mm<br>Needle gauge : 20mm                        |  |
|---|---|--|--|--|
| G1-1-3<br>針抱キ組<br>Needle clamp assy                 |   | S59144-001<br>針抱キ18UP組<br>Needle clamp assy,<br>18mm   | S59145-001<br>針抱キ20UP組<br>Needle clamp assy,<br>20mm |  |
| G1-6<br>針板セット<br>Needle plate set                   |   | S52576-001<br>針板18セット<br>Needle plate set, 18          | S52577-001<br>針板20セット<br>Needle plate set, 20        |  |
| G1-3-3<br>針板組<br>Needle plate assy                  |   | S52566-001<br>針板18組<br>Needle plate assy, 18           | S52567-001<br>針板20組<br>Needle plate assy, 20         |  |
| G1-4-3<br>ループガイド<br>Loop guide                      |   | S52541-001<br>ループガイド18<br>Loop guide, 18               | S52542-001<br>ループガイド20<br>Loop guide, 20             |  |
| G2-1-2<br>滑り板セット<br>Slide plate set                 |   | S53437-000<br>滑り板セット18-20<br>Slide plate set, 18-20    |  |  |
| G2-1-2-1<br>滑り板組<br>Slide plate assy                |   | S53438-000<br>滑り板組18-20<br>Slide plate assy, 18-20     |  |  |
| G2-1-2-2<br>滑り板<br>Slide plate                      |   | S53430-003<br>生地滑り板<br>Slide plate                     |  |  |
| 定規 / Binder   | G2-10<br>両玉縁縫い<br>Double welting<br> | 中厚物用<br>Medium-weight<br>materials                     | S59291-000<br>定規組18W-33<br>Binder assy, 18W-33       | S59295-000<br>定規組20W-37<br>Binder assy, 20W-37 |
|   |                                      | 薄物用<br>Light-weight<br>materials                       | S59292-000<br>定規組18W-34<br>Binder assy, 18W-34       | S59296-000<br>定規組20W-38<br>Binder assy, 20W-38 |
|   | G2-20<br>片玉縁縫い<br>Single welting<br> | 中厚物用<br>Medium-weight<br>materials                     | S59293-000<br>定規組18S-34<br>Binder assy, 18S-34       | S59297-000<br>定規組20S-38<br>Binder assy, 20S-38 |
|   |                                      | 薄物用<br>Light-weight<br>materials                       | S59294-000<br>定規組18S-35<br>Binder assy, 18S-35       | S59298-000<br>定規組20S-39<br>Binder assy, 20S-39 |
| AC-25-1,25-2<br>セラミックコーナーメス<br>Ceramic corner knife |   | S14051-001<br>セラミックコーナーメス L<br>Ceramic corner knife, L |  |  |
| AC-24<br>メスダイ組<br>Knife base assy                   |   | S11526-001<br>メスダイ18組<br>Knife base assy, 10           | S11527-001<br>メスダイ20組<br>Knife base assy, 20         |  |
| L2-2-2, 2-3<br>固定刃<br>Fixed knife                   |   | S53496-001<br>固定刃 18-20<br>Fixed knife, 18-20          |  |  |
| L2-3-2, 3-3<br>上糸メス<br>N/Thread knife assy          |   | S53503-101<br>上糸メス18-20組<br>N/Thread knife assy, 18-20 |  |  |
| L2-4-2, 4-3<br>糸保持板<br>Thread holding plate         |   | S53509-001<br>糸保持板18-20<br>Thread holding plate, 18-20 |  |  |

Ga2 . ゲージ部品一覧表 (BAS-6150) / Gauge parts List (BAS-6150)

|             |  | 針幅8mm<br>Needle gauge : 8mm   | 針幅10mm<br>Needle gauge : 10mm   | 針幅12mm<br>Needle gauge : 12mm   | 針幅14mm<br>Needle gauge : 14mm   | 針幅16mm<br>Needle gauge : 16mm   |
|-------------|--|---|---|---|---|---|
| 定規 / Binder | G2-10-2<br>両玉縁縫い<br>Double welting<br>   | <b>S54651-000</b><br>定規 8W-13<br>Binder, 8W-13<br>   | <b>S54655-000</b><br>定規 10W-17<br>Binder, 10W-17<br>   | <b>S54659-000</b><br>定規 12W-21<br>Binder, 12W-21<br>   | <b>S54663-000</b><br>定規 14W-25<br>Binder, 14W-25<br>    | <b>S54667-000</b><br>定規 16W-29<br>Binder, 16W-29<br>   |
|             |    | <b>S53445-000</b><br>定規 8W-14<br>Binder, 8W-14<br>  | <b>S53451-000</b><br>定規 10W-18<br>Binder, 10W-18<br>  | <b>S53455-000</b><br>定規 12W-22<br>Binder, 12W-22<br>  | <b>S53459-000</b><br>定規 14W-26<br>Binder, 14W-26<br>  | <b>S53463-000</b><br>定規 16W-30<br>Binder, 16W-30<br>  |
|             | G2-20-2<br>片玉縁縫い<br>Single welting<br> | <b>S54653-000</b><br>定規 8S-14<br>Binder, 8S-14<br> | <b>S54657-000</b><br>定規 10S-18<br>Binder, 10S-18<br> | <b>S54661-000</b><br>定規 12S-22<br>Binder, 12S-22<br> | <b>S54665-000</b><br>定規 14S-26<br>Binder, 14S-26<br> | <b>S54669-000</b><br>定規 16S-30<br>Binder, 16S-30<br> |
|             |                                        | <b>S53449-000</b><br>定規 8S-15<br>Binder, 8S-15<br> | <b>S53453-000</b><br>定規 10S-19<br>Binder, 10S-19<br> | <b>S53457-000</b><br>定規 12S-23<br>Binder, 12S-23<br> | <b>S53461-000</b><br>定規 14S-27<br>Binder, 14S-27<br> | <b>S53465-000</b><br>定規 16S-31<br>Binder, 16S-31<br> |

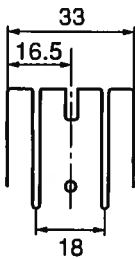
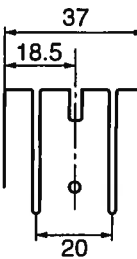
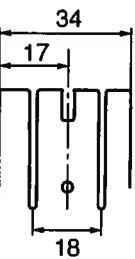
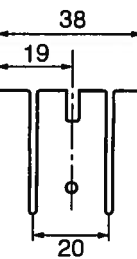
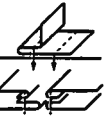
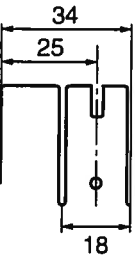
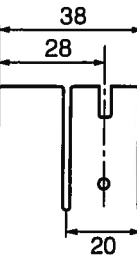
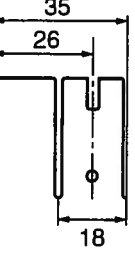
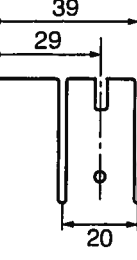

Ga2 . ゲージ部品一覧表 (BAS-6150) / Gauge parts List (BAS-6150)

|             |  | 針幅18mm<br>Needle gauge : 18mm   | 針幅20mm<br>Needle gauge : 20mm   |
|-------------|--|---|---|
| 定規 / Binder | G2-10-2<br>両玉縁縫い<br>Double welting<br><br>   | <b>S54671-000</b><br>定規 18W-33<br>Binder, 18W-33<br><br>   | <b>S54675-000</b><br>定規 20W-37<br>Binder, 20W-37<br><br>   |
|             |  | <b>S53467-000</b><br>定規 18W-34<br>Binder, 18W-34<br><br>  | <b>S53471-000</b><br>定規 20W-38<br>Binder, 20W-38<br><br>  |
|             | G2-20-2<br>片玉縁縫い<br>Single welting<br><br> | <b>S54673-000</b><br>定規 18S-34<br>Binder, 18S-34<br><br> | <b>S54677-000</b><br>定規 20S-38<br>Binder, 20S-38<br><br> |
|             |  | <b>S53469-000</b><br>定規 18S-35<br>Binder, 18S-35<br><br> | <b>S53473-000</b><br>定規 20S-39<br>Binder, 20S-39<br><br> |

Wa. 警告ラベル / Warning labels

| 警告ラベル / Warning labels | 品名 / Name of parts         | Size(mm)   | Code       |
|------------------------|----------------------------|------------|------------|
|                        | 電撃ラベル・和                    | 40 X 64    | S38353-101 |
|                        | Label, elec. shock 4 lang. | 35 X 118   | S38352-101 |
|                        | 操作注意ラベルBAS・和               | 40 X 64    | S38357-001 |
|                        |                            | 52 X 84    | S38357-002 |
|                        | Label, operation(BAS)Eng.  | 40 X 64    | S38571-001 |
|                        |                            | 52 X 84    | S38571-002 |
|                        | ワーニングマーク<br>Mark, injury   | L=16       | S36924-001 |
|                        |                            | L=25       | S36924-002 |
|                        | 矢印マーク<br>Label, arrow      | 10 X 30    | S37058-001 |
|                        | PE マーク<br>Label, PE        | 7.5 X 12.5 | S37059-001 |
|                        | アースマーク<br>Label, grounding | Ø 12       | S37060-001 |

| CODE      | REF.NO  | Page | CODE      | REF.NO  | Page | CODE      | REF.NO | Page | CODE      | REF.NO  | Page |
|-----------|---------|------|-----------|---------|------|-----------|--------|------|-----------|---------|------|
| 002021205 | 101     | 70   | 012500536 | 8       | 24   | 018300636 | 6      | 24   | 021060206 | 1-88    | 30   |
| 002300403 | 1-11    | 54   |           | 24      | 24   |           | 110    | 50   |           | 1-110   | 32   |
| 002300603 | 78      | 38   |           | 1-9     | 64   |           | 1-11   | 54   | 021080206 | 1-63    | 30   |
|           | 1-1-27  | 44   |           | 1-19    | 64   |           | 177    | 58   |           | 1-84    | 30   |
|           | 1-2-27  | 46   |           | 1-49    | 64   |           | 201    | 58   |           | 1-15    | 56   |
|           | 50-23   | 48   |           | 17      | 70   | 018300836 | 1-1-7  | 12   |           | 9-22    | 68   |
|           | 51-24   | 48   | 013660612 | 1-26    | 20   |           | 1-2-7  | 12   | 021080306 | 65      | 57   |
|           | 106     | 48   | 013710512 | 10      | 14   |           | 176    | 58   | 021120304 | 9-33    | 68   |
|           | 5       | 66   |           | 50      | 16   |           | 9-63   | 70   | 021300303 | 9-65    | 70   |
| 002501003 | 1-44    | 64   | 013711012 | 17      | 14   | 018301036 | 1-38   | 64   | 021400103 | 1-25    | 34   |
| 004300513 | 1-1-5   | 12   | 014060632 | 31-19-1 | 72   | 018301236 | 25     | 24   | 021400206 | 1-1-1-4 | 12   |
|           | 1-2-5   | 12   | 014300332 | 1-30    | 34   |           | 9-57   | 68   |           | 1-2-1-4 | 12   |
|           | 1-3     | 34   | 014680422 | 1-9     | 34   |           | 9-60   | 70   | 021500106 | 31-11-3 | 72   |
| 004301016 | 9-86    | 70   | 014761030 | 19-1    | 4    |           | 9-64   | 70   |           | 31-18-1 | 72   |
| 004400603 | 1-3     | 54   | 014770622 | 1-23    | 60   | 018400836 | X2     | 52   |           | 31-19-2 | 72   |
| 004401003 | 44      | 16   | 014771022 | B6-4    | 2    |           | 15     | 70   | 021500216 | 50-13   | 48   |
|           | 1-23    | 56   |           | B16     | 2    | 018401036 | 29     | 4    |           | 50-20   | 48   |
|           | 156     | 57   |           | 15      | 4    |           | 1-19   | 60   |           | 51-14   | 48   |
| 004401414 | 1-1-1-3 | 12   |           | 1-2     | 8    |           | 9-19   | 68   |           | 51-21   | 48   |
|           | 1-2-1-3 | 12   | 014780622 | 1-12    | 6    | 018401236 | 1-20   | 56   |           | 1-55    | 64   |
| 004501003 | 9-10    | 68   | 014781032 | B3      | 2    |           | 1-24   | 60   |           | 9-46    | 68   |
| 004501606 | 50-5    | 48   |           | 2       | 4    | 018401236 | 27     | 62   | 021500316 | P1-14   | 28   |
|           | 51-5    | 48   |           | 23      | 4    | 018401436 | 40     | 8    | 021670102 | 34      | 22   |
| 008300604 | 1-1-32  | 44   |           | 201     | 6    |           | 1-24   | 64   | 025030233 | 1-7     | 34   |
|           | 1-2-32  | 46   | 016771032 | 16      | 4    | 018401636 | 60     | 56   | 025030236 | 1-13    | 54   |
|           | 50-18   | 48   | 017061616 | 51      | 56   |           | 1-27   | 64   |           | 6       | 66   |
|           | 51-19   | 48   | 017082016 | 1-3     | 56   | 018500836 | 45     | 56   |           | 9-90    | 70   |
| 008400604 | 9-5     | 36   |           | 23      | 66   |           | 1-47   | 64   |           | 9-91    | 70   |
|           | 1-1-9   | 44   | 017083016 | 84      | 57   | 018501022 | 158    | 57   | 025040135 | 152     | 18   |
|           | 1-2-9   | 44   | 018061036 | 1-58    | 30   | 018501036 | 1-1-21 | 44   | 025040136 | 42      | 8    |
|           | 50-2    | 48   | 018061236 | 1-106   | 32   |           | 1-2-21 | 46   | 025040233 | 1-23    | 34   |
|           | 51-2    | 48   | 018061422 | 1-35    | 64   |           | 50-9   | 48   | 025040236 | X3      | 52   |
|           | 104     | 48   | 018061436 | 30      | 40   |           | 51-9   | 48   |           | 29      | 62   |
|           | 68      | 57   |           | 21      | 60   |           | 9-13   | 68   | 025050236 | 1-8     | 60   |
|           | 75      | 57   |           | 9-81    | 70   |           | 9-42   | 68   |           | 1-34    | 60   |
|           | 82      | 57   | 018061636 | 1-57    | 64   | 018501236 | 1-1-13 | 44   |           | 1-45    | 64   |
|           | 101     | 57   | 018062022 | 1-2     | 64   |           | 1-2-13 | 44   |           | 9-44    | 68   |
|           | 163     | 57   | 018062036 | 1-1-5   | 44   |           | X5     | 52   | 025060236 | 1-87    | 30   |
|           | 165     | 57   |           | 1-2-5   | 44   |           | 1-37   | 60   |           | 1-1-7   | 44   |
|           | 181     | 58   |           | 1-3     | 60   |           | 1-22   | 64   |           | 1-2-7   | 44   |
|           | 195     | 58   |           | 1-35    | 60   |           | 1-32   | 64   |           | 1-3     | 64   |
|           | 1-30    | 60   |           | 18      | 66   |           | 121    | 66   | 025060236 | 1-109   | 32   |
|           | 1-51    | 64   |           | 9-52    | 68   | 018501436 | 154    | 57   | 025080236 | 1-36    | 30   |
|           | 1-60    | 66   | 018062536 | N10     | 26   |           | 1-32   | 60   |           | 1-62    | 30   |
|           | 12      | 66   | 018063022 | 202-2   | 6    | 018501622 | 1-42   | 30   |           | 1-83    | 30   |
|           | 14      | 66   | 018063036 | N2      | 26   | 018501636 | A11    | 2    |           | 1-103   | 30   |
|           | 33      | 72   |           | 1-46    | 30   |           | 1-6    | 60   |           | 1-5     | 56   |
| 008400804 | Q1-10   | 28   |           | 1-107   | 32   |           | 1-27   | 60   |           | 86      | 57   |
| 012060636 | 14      | 24   |           | 56      | 56   |           | 1-30   | 64   |           | 9-17    | 68   |
|           | 1-1-3   | 44   | 018064036 | 1-85    | 30   |           | 1-53   | 64   |           | 9-23    | 68   |
|           | 1-2-3   | 44   | 018081636 | 1-50    | 30   |           | 9-3    | 68   | 025080336 | 1-16    | 56   |
|           | 1-7     | 56   | 018082036 | 1-34    | 30   |           | 9-48   | 68   | 025100232 | 44      | 8    |
|           | 1-17    | 64   |           | 151     | 57   |           | 9-54   | 68   | 025100236 | 1-6     | 30   |
|           | 123     | 66   |           | 9-77    | 70   | 018502036 | 1-37   | 30   |           | 1-31    | 30   |
|           | 9-37    | 68   | 018082536 | 9-15    | 68   |           | 1-9    | 60   |           | 4       | 56   |
| 012081636 | 63      | 57   | 018083036 | 1-101   | 30   |           | 1-40   | 64   |           | 9       | 56   |
| 012300336 | 13      | 70   |           | 1-81    | 30   |           | 16     | 66   | 025680132 | 1-15    | 6    |
| 012400436 | 1-18    | 56   | 018102036 | 1-29    | 30   | 018503036 | 1-112  | 32   | 025710232 | 12-3    | 14   |
|           | 1-13    | 60   |           | 3       | 56   |           | 3      | 36   |           | 39      | 22   |
|           | 9-74    | 70   | 018103036 | 7       | 56   |           | 9-6    | 68   | 026050136 | 31-18-6 | 72   |
| 012500536 | 23      | 60   | 018108036 | 1-4     | 30   | 021060206 | 9-82   | 70   | 026060136 | 1-58    | 64   |

## 索引 / INDEX

| CODE      | REF.NO  | Page | CODE      | REF.NO  | Page | CODE      | REF.NO | Page | CODE      | REF.NO  | Page |
|-----------|---------|------|-----------|---------|------|-----------|--------|------|-----------|---------|------|
| 028030242 | W4      | 52   | 047200642 | Q1-7    | 28   | 0A4300805 | Q1-4   | 28   | 112592001 | 1-4-1   | 6    |
| 028030246 | 1-1-8   | 12   | 047301042 | 1-16    | 34   | 0A4400805 | 1-10   | 54   | 112593001 | 1-5     | 6    |
|           | 1-2-8   | 12   | 048025342 | 1-1-25  | 44   | 0A5300805 | 21     | 40   | 112594051 | 2       | 6    |
|           | 1-12    | 54   |           | 1-2-25  | 46   | 0A5400805 | Q1-13  | 28   | 112684001 | B5-1    | 2    |
|           | 9-58    | 68   | 048050346 | 1-15    | 54   |           | 5      | 34   | 112700001 | 27-1    | 14   |
| 028040243 | 1-22    | 34   | 048060142 | 13      | 24   |           | 6      | 40   | 112709001 | 1-20    | 20   |
|           | 1-25    | 60   |           | 1-15    | 60   |           | 11     | 40   |           | 3       | 20   |
| 028040246 | 30      | 4    | 048100142 | 12      | 24   |           | 13     | 40   | 112712001 | 1-10    | 20   |
|           | 41      | 8    | 048150142 | 1-14    | 64   |           | 15     | 40   | 112717001 | 10      | 16   |
|           | 61      | 57   | 048160242 | 1-11    | 60   |           | 28     | 40   | 112721001 | 1-6     | 6    |
|           | 204     | 58   | 048200142 | 1-54    | 30   |           | 42     | 40   | 112728001 | 56      | 16   |
|           | 1-20    | 60   | 052400606 | 1-16    | 54   |           | 122    | 50   | 112735000 | 58      | 16   |
|           | 1-33    | 60   | 060400812 | 1-1-16  | 44   |           | W9     | 52   | 112753001 | 16      | 16   |
|           | 28      | 62   |           | 1-2-16  | 44   |           | 104    | 70   | 112753001 | 40      | 16   |
|           | 1-25    | 64   | 060660512 | 1-14    | 34   | 0A5401005 | 75     | 38   | 112758001 | 143     | 18   |
|           | 1-28    | 64   | 060681212 | 130     | 18   |           | 37     | 40   | 113014000 | 10      | 4    |
|           | 9-20    | 68   | 062060806 | 31-3-1  | 72   |           | 39     | 40   | 113024000 | 25      | 4    |
|           | N7      | 26   | 062061012 | 1-42    | 64   |           | 72     | 40   | 113386000 | A2      | 2    |
| 028050246 | 4       | 36   | 062300606 | P1-4    | 28   |           | 123    | 62   | 114483002 | 22      | 74   |
| 028050246 | 1-38    | 30   |           | P1-8    | 28   |           | 108    | 66   | 114486002 | 32      | 74   |
|           | 1-113   | 32   |           | P1-9    | 28   | 0A5401006 | 167    | 57   | 114693001 | 57      | 16   |
|           | 1-1-14  | 44   | 062300616 | 1-6     | 34   | 0A5401205 | W10    | 52   | 115157001 | 1       | 74   |
|           | 1-2-14  | 44   | 062300806 | 102     | 66   | 100064002 | 2      | 20   | 115503001 | 1-1-20  | 44   |
|           | X6      | 52   | 062301006 | 103     | 62   | 100136001 | 1-20   | 34   |           | 1-2-20  | 46   |
|           | 1-7     | 60   | 062301205 | 1-6     | 54   | 100197002 | 4      | 14   |           | 50-8    | 48   |
|           | 1-28    | 60   | 062302506 | W3      | 52   | 100250001 | 7      | 4    |           | 51-8    | 48   |
|           | 1-38    | 60   | 062400805 | 203     | 58   | 100251001 | B5-2   | 2    | 116920001 | 1-16    | 64   |
|           | 17      | 66   | 062401006 | 1-24    | 34   |           | 12     | 4    | 117436001 | Q1-5    | 28   |
|           | 9-4     | 68   | 062501406 | 31-18-2 | 72   |           | 42     | 22   | 117466000 | 20      | 74   |
|           | 9-7     | 68   |           | 31-18-4 | 72   | 100401001 | 1-19   | 34   | 117934001 | 133     | 18   |
|           | 9-14    | 68   | 062503506 | 31-18-3 | 72   | 100645003 | N6     | 26   | 117936001 | 1-17    | 54   |
|           | 9-45    | 68   |           | 31-19-3 | 72   | 100887001 | 10     | 74   | 118064001 | 3       | 74   |
|           | 9-49    | 68   | 062670512 | 27      | 4    | 101572101 | 18     | 74   | 118550001 | 62-2    | 57   |
|           | 9-55    | 68   |           | 23      | 16   | 101706001 | 11     | 4    | 118837001 | 17      | 74   |
|           | 31-11-2 | 72   |           | 83      | 16   | 102731004 | 1-2    | 6    | 118954000 | 3       | 8    |
| 028060246 | N11     | 26   |           | 148     | 18   | 104821001 | A8     | 2    | 120752001 | 41      | 22   |
|           | 1-86    | 30   |           | 1-21    | 20   |           | 31     | 16   | 122991001 | 15      | 74   |
|           | 1-108   | 32   |           | 4       | 20   |           | 135    | 18   | 126863001 | 31-6    | 72   |
|           | 31      | 40   |           | 170-3   | 57   |           | 1-33   | 64   | 131007001 | B5-3    | 2    |
|           | 1-1-6   | 44   | 062670612 | 101     | 16   | 105173004 | 169    | 57   | 133172003 | 180     | 58   |
|           | 1-2-6   | 44   |           | 151     | 18   | 105216001 | 19     | 8    | 138843001 | 31-13   | 72   |
|           | 52      | 56   | 062670812 | 1-4-2   | 6    | 107017002 | 9      | 8    | 140527001 | 13-1    | 20   |
|           | 57      | 56   |           | 1-10    | 6    | 107153002 | 41     | 56   | 140682001 | 1-111-4 | 32   |
|           | 1-4     | 64   |           | 44      | 22   | 107780001 | 9      | 74   |           | 1-6     | 36   |
| 028080246 | 1-35    | 30   | 062671412 | 78      | 16   | 108254001 | 1-4    | 20   |           | 2-4     | 36   |
|           | 1-51    | 30   |           | 33      | 22   | 108265009 | 1-6    | 20   | 140890009 | 30      | 16   |
|           | 1-61    | 30   | 062680812 | 6       | 20   | 108266001 | 7      | 20   | 141544001 | 46      | 22   |
|           | 1-82    | 30   | 062681212 | 31      | 8    | 108802001 | 64     | 16   | 141598001 | 11      | 70   |
|           | 1-102   | 30   |           | 30      | 22   | 108960002 | 25     | 8    | 142002001 | 6       | 74   |
|           | 1-4     | 56   | 062681412 | 1-14    | 6    |           | 26     | 14   | 142205001 | 11      | 74   |
|           | 85      | 57   | 062682012 | 10      | 24   |           | 10     | 20   | 142274101 | 21-2    | 4    |
|           | 24      | 66   | 062710612 | 123     | 16   | 110161006 | 12-4   | 14   |           | 200-4   | 18   |
|           | 9-16    | 68   | 062711212 | 11      | 16   | 110744002 | 10     | 8    | 142443001 | 16      | 74   |
| 028100246 | 1-5     | 30   | 062782512 | 3       | 14   | 111140002 | 26     | 62   | 142721001 | 4       | 74   |
|           | 1-30    | 30   | 072600480 | B6-2    | 2    | 111865001 | 131    | 18   | 142990001 | 31-16-3 | 72   |
|           | 5       | 56   | 076002450 | 1-11    | 64   | 111942001 | 1-12   | 34   | 144504001 | 1-16    | 20   |
|           | 8       | 56   | 081014670 | 140     | 18   | 111943001 | 1-13   | 34   | 144526001 | 37      | 22   |
| 028260242 | 1-28    | 34   | 087310815 | 1-7     | 54   | 112301001 | 12-3   | 20   |           | 36      | 56   |
| 032311306 | 2       | 34   | 087311015 | 1-8     | 54   | 112467002 | B15    | 2    | 144875001 | B13     | 2    |
| 032422505 | 3       | 54   | 0A4300605 | 45      | 40   | 112576001 | 13     | 4    | 145446001 | 1-13    | 20   |
| 039411215 | 94      | 57   |           | 110     | 70   | 112590001 | 1-1    | 6    | 145446001 | 1-18    | 34   |

| CODE      | REF.NO   | Page | CODE      | REF.NO  | Page | CODE      | REF.NO | Page | CODE      | REF.NO   | Page |
|-----------|----------|------|-----------|---------|------|-----------|--------|------|-----------|----------|------|
| 145446001 | 1-18     | 34   | 153012101 | 200     | 6    | S04557000 | 149    | 18   | S08604001 | 1-1      | 20   |
| 145571101 | 1-17     | 34   | 153057102 | 33      | 8    |           | 1-130  | 32   | S08605101 | 1-22     | 20   |
| 146124001 | 1-5      | 20   | 153208002 | 7       | 10   |           | 101    | 32   | S08606001 | 1-23     | 20   |
| 146141001 | 8        | 4    |           | 9       | 10   |           | X11    | 52   | S08607001 | 1-2      | 20   |
| 146197001 | 1-21     | 34   | 153230101 | 170-2   | 57   |           | 124    | 62   | S08608001 | 1-3      | 20   |
| 146360002 | 38       | 22   | 153242000 | W8-5    | 52   | S06994001 | 35     | 8    | S08609201 | 1-24     | 20   |
| 146427001 | 1-1-1    | 10   |           | 54      | 74   | S07327001 | 147    | 18   | S08610101 | 1-25     | 20   |
|           | 1-2-1    | 10   | 153252000 | 5-2     | 36   | S07333001 | 41-2   | 16   | S09043000 | 17       | 16   |
| 148005001 | 12-2     | 14   | 153274001 | 1-111-5 | 32   | S07334001 | 22     | 4    | S09132051 | 202      | 6    |
| 148394000 | 29       | 16   |           | 1-7     | 36   | S07338001 | 24     | 4    | S09141000 | 74       | 42   |
| 148536001 | 48       | 22   |           | 2-5     | 36   | S07339209 | 26     | 4    | S09142000 | 75       | 42   |
| 148539101 | 27       | 8    | 153568001 | 1-19    | 56   | S07356001 | 10     | 56   | S09231000 | 5-1      | 36   |
|           | 50       | 22   | 154024001 | 1-4     | 34   | S07417001 | 9      | 14   | S09259001 | 5        | 14   |
| 148762001 | 37       | 16   | 154092001 | 1-8     | 34   | S07419001 | 8      | 14   | S09260001 | 6-1      | 14   |
| 148821001 | B6-3     | 2    | 154125001 | 5       | 74   | S07420000 | 7      | 14   | S09261001 | 6-2      | 14   |
|           | B17      | 2    | 154560001 | 1-17    | 20   | S07436001 | 24     | 14   | S09273001 | 23-1-2   | 14   |
| 149287000 | 72       | 38   | 154886001 | 58      | 56   | S07437001 | 25     | 14   | S09284001 | 23-2-5   | 14   |
|           | 73       | 42   | 154965001 | 52      | 14   | S07446001 | B6     | 2    | S09285051 | 41       | 14   |
|           | 121      | 50   |           | 53      | 14   | S07447001 | B6-1   | 2    |           | 8        | 72   |
| 149566109 | 1-15     | 20   | 155479001 | 23-2-1  | 14   | S07459100 | 200-3  | 18   | S09286000 | 42       | 14   |
| 149796001 | 20       | 36   | 155510001 | 1-18    | 20   | S07462000 | 69     | 16   | S10078001 | 1-17     | 60   |
| 150172003 | 31-17    | 72   | 158115001 | B7-2    | 2    | S07463000 | 70     | 16   | S10079101 | 1-18     | 60   |
| 150173003 | 31-10    | 72   |           | 18      | 4    | S07464100 | 200-5  | 18   | S10087101 | 1-12     | 60   |
| 150174000 | 31-9-1   | 72   | 158581000 | 74      | 38   | S07465000 | 55     | 16   | S10133000 | 1-5      | 60   |
| 150179002 | 31-11-1  | 72   | 158597001 | 1-32    | 34   | S07469001 | 129-7  | 18   | S10134001 | 1-14     | 60   |
| 150182000 | 31-5     | 72   | 158768001 | 1-7     | 20   | S07471001 | 22     | 16   | S10243000 | 120      | 50   |
| 150183000 | 31-16-2  | 72   | 158769001 | 1-12    | 20   | S07476000 | 36     | 16   |           | 103      | 70   |
| 150185009 | 31-12    | 72   | 159027001 | 50      | 56   | S07477000 | 4      | 16   | S10243000 | Q1-12    | 28   |
| 150189109 | 31-1     | 72   | 159150000 | 159     | 57   | S07478000 | 5      | 16   | S10661109 | 14       | 56   |
| 150335001 | 2        | 74   | 159802001 | 23-2-4  | 14   |           | 126    | 18   | S10859001 | 77       | 38   |
| 150553003 | 13-2     | 20   | 159805001 | 1-14    | 20   | S07481009 | 144    | 18   | S11433000 | 1-1-22-3 | 44   |
| 150936001 | 5        | 8    | 159928000 | A9      | 2    | S07487101 | 1-8    | 20   |           | 1-2-22-3 | 46   |
| 150937101 | 6        | 8    | 228475000 | 1-7     | 54   | S07488001 | 1-11   | 20   | S11433000 | P1-13    | 28   |
| 150938201 | 7        | 8    | 530138001 | 1-10    | 60   | S07490001 | 1-19   | 20   | S11521001 | 24-1     | 60   |
| 150967101 | 11       | 14   | 552907000 | 71      | 40   | S07519001 | 31     | 22   |           | Ga1      | 75   |
| 150988001 | 9        | 16   |           | 122     | 62   | S07520001 | 32     | 22   | S11522001 | 24-2     | 60   |
| 151027001 | 23-1-1-1 | 14   | 552907000 | 106     | 66   | S07521001 | 35     | 22   |           | Ga1      | 75   |
| 151029001 | 23-2-2   | 14   | 552908000 | 73      | 38   | S07522001 | 36     | 22   | S11523001 | 24-3     | 60   |
| 151030001 | 23-2-3   | 14   |           | 38      | 40   | S07524101 | 43     | 22   |           | Ga1      | 75   |
| 151090001 | 8        | 8    | 625010000 | 121     | 62   | S07525000 | 45     | 22   | S11524001 | 24-4     | 60   |
| 151148001 | 1-27     | 20   |           | 105     | 66   | S07527001 | 49-1   | 22   |           | Ga1      | 75   |
| 151951001 | 37       | 56   |           | 109     | 70   | S07571000 | 39     | 16   | S11525001 | 24-5     | 60   |
| 152356301 | 1-1      | 34   | J02727001 | W8-7    | 52   | S07658001 | 27     | 14   |           | Ga1      | 75   |
| 152361001 | 1-10     | 34   |           | 55      | 74   | S07783001 | 7      | 74   | S11526001 | 24-6     | 60   |
| 152362001 | 1-11     | 34   | J80869001 | N12     | 26   | S07876101 | 91     | 16   |           | Ga1      | 76   |
| 152363001 | 1-15     | 34   | S00480000 | 70      | 40   | S08030000 | W8-4   | 52   | S11527001 | 24-7     | 60   |
| 152364001 | 1-31     | 34   | S00554000 | 23      | 40   |           | 53     | 74   |           | Ga1      | 76   |
| 152565000 | W8-2     | 52   | S01943001 | 19      | 74   | S08132001 | 12     | 74   | S12067000 | 1-13     | 64   |
|           | 51       | 74   | S02606000 | 139     | 18   | S08170001 | 13     | 74   | S12076000 | 1-8      | 64   |
| 152566000 | W8-1     | 52   | S02738009 | 91      | 57   | S08205000 | 205    | 58   | S12078000 | 1-5      | 64   |
|           | 50       | 74   | S02739000 | 93      | 57   | S08238000 | 9-28   | 68   | S12079000 | 1-7      | 64   |
| 152645001 | 1-5      | 34   | S02740000 | 92      | 57   |           | 9-39   | 68   | S12150000 | 1-1-22-2 | 44   |
| 152651401 | 1        | 34   | S02767409 | 31      | 72   | S08239000 | 9-29   | 68   |           | 1-2-22-2 | 46   |
| 152725000 | 202-1    | 6    | S02779009 | 31-15   | 72   |           | 9-40   | 68   |           | 50-10-2  | 48   |
| 152914001 | N4       | 26   | S02788009 | 31-16   | 72   | S08240000 | 9-30   | 68   |           | 51-10-2  | 48   |
| 152948001 | 49       | 16   | S02789009 | 31-16-1 | 72   | S08280000 | 9-50   | 68   |           | 14-2     | 70   |
| 153011014 | A4-2     | 2    | S03289001 | 21-1    | 4    | S08332000 | 9-27   | 68   | S12445051 | B5       | 2    |
| 153011016 | 7-1      | 72   | S03999009 | 15      | 56   | S08338001 | 9-35   | 68   | S12463001 | 44       | 40   |
|           | A4-1     | 2    | S04109001 | 31-7    | 72   | S08339001 | 9-36   | 68   | S12506000 | 9-4      | 36   |
| 153011018 | A4-3     | 2    | S04505000 | 107     | 66   | S08342001 | 9-31   | 68   | S13021001 | 16       | 14   |
| 153011416 | 7        | 72   | S04557000 | 71      | 38   | S08352000 | 9-12   | 68   | S14050001 | 25-1     | 60   |

## 索引 / INDEX

| CODE      | REF.NO   | Page | CODE      | REF.NO  | Page | CODE      | REF.NO | Page | CODE      | REF.NO | Page |
|-----------|----------|------|-----------|---------|------|-----------|--------|------|-----------|--------|------|
| S14050001 | 25-2     | 60   | S38213051 | 12-1    | 14   | S42466001 | 32     | 56   | S52486101 | A12    | 2    |
|           | Ga1      | 75   | S38237001 | B7      | 2    | S42619001 | 1-17   | 56   | S52487001 | 5      | 4    |
| S14051001 | Ga1      | 75   | S38241051 | 14      | 4    | S42867001 | 1-2    | 54   | S52490001 | P1-20  | 28   |
|           | Ga1      | 76   | S38244100 | 17      | 4    | S43192200 | 1-21   | 60   |           | 70     | 74   |
| S14189100 | 200-1    | 18   | S38245051 | B7-1    | 2    | S44807000 | 1-5-1  | 54   | S52491001 | 28     | 4    |
| S14666000 | 1-1-22-1 | 44   | S38248001 | 3       | 16   | S46191001 | 1-55   | 30   | S52493001 | N1     | 26   |
|           | 1-2-22-1 | 46   | S38251000 | 119     | 16   | S46583000 | 96     | 57   | S52495101 | 1      | 6    |
|           | 50-10-1  | 48   | S38253001 | B4      | 2    | S46738000 | 20     | 40   | S52497001 | 1-7    | 6    |
|           | 51-10-1  | 48   | S38261001 | 120     | 16   | S47900000 | 7-1    | 40   | S52498001 | 1-8    | 6    |
| S14677001 | 5        | 20   | S38264001 | 121     | 16   | S48715000 | 2      | 8    | S52499001 | 1-9    | 6    |
|           | M1-3     | 26   | S38266000 | 35      | 16   | S48716001 | 4      | 8    | S52500001 | 1-11   | 6    |
| S14696001 | 8        | 74   | S38269000 | 38      | 16   | S48724001 | B2-1   | 2    | S52507001 | 1      | 8    |
| S14703001 | 10       | 70   | S38270001 | 1       | 4    | S48732001 | B14    | 2    | S52508001 | 1-1    | 8    |
| S14753001 | 22       | 60   | S38274001 | 1-9     | 20   | S48734000 | 76     | 16   | S52509001 | 12     | 8    |
| S14874000 | 43       | 8    | S38292001 | 6       | 16   | S48737000 | 108    | 16   | S52512001 | 14     | 8    |
| S15097000 | M1-1     | 26   |           | 124     | 18   | S48738000 | 109    | 16   | S52514001 | 17     | 8    |
| S15584509 | 1        | 20   | S38295000 | B1      | 2    | S48739001 | 110    | 16   | S52518000 | 28     | 8    |
| S16350001 | 15       | 8    | S38299001 | 7       | 16   | S48740001 | 111    | 16   | S52519000 | 28-1   | 8    |
| S16603000 | 15-2     | 24   |           | 125     | 18   | S48760001 | 12-1   | 20   | S52520001 | 30     | 8    |
| S16669000 | 1-33     | 34   | S38352101 | Wa      | 79   | S48761001 | 12-2   | 20   | S52521001 | 37     | 8    |
| S17533000 | 9-8      | 68   | S38353101 | Wa      | 79   | S48763001 | 129-1  | 18   | S52523001 | A10    | 2    |
| S17971000 | 39       | 56   | S38357001 | Wa      | 79   | S48776000 | 11     | 8    | S52524001 | 1-13   | 6    |
| S20355002 | 19       | 70   | S38357002 | Wa      | 79   | S49491000 | 1-1-1  | 54   | S52525001 | 8      | 10   |
| S20849101 | 38       | 8    | S38396000 | 6       | 4    | S49495000 | 1-3    | 54   | S52536001 | 4-3    | 10   |
| S21008001 | 9-71     | 70   | S38398001 | 9       | 4    | S49496001 | 1-4    | 54   |           | Ga1    | 75   |
| S21009001 | 9-72     | 70   | S38404001 | 21      | 4    | S49529001 | 12     | 20   | S52537001 | 4-1    | 10   |
| S21195001 | 82       | 16   | S38419001 | 28      | 22   | S49530001 | 12-4   | 20   |           | Ga1    | 75   |
| S21196001 | 134      | 18   | S38420001 | 29      | 22   | S49564002 | 132    | 18   | S52538001 | 4-2    | 10   |
| S21798001 | 31-11    | 72   | S38448000 | 200-2   | 18   | S49638001 | 40     | 56   |           | Ga1    | 75   |
| S21921001 | 5        | 10   | S38481000 | 63      | 16   | S51283001 | 31-4   | 72   | S52539001 | 4-3    | 10   |
| S27844201 | 1-22     | 60   | S38541000 | 75      | 16   | S52092000 | 1-5    | 54   |           | Ga1    | 75   |
| S29742001 | 1-54     | 64   | S38571001 | Wa      | 79   | S52437000 | 7-2    | 40   | S52540001 | 4-3    | 10   |
| S29863001 | 1-4      | 6    | S38571002 | Wa      | 79   | S52439000 | 17     | 40   |           | Ga1    | 75   |
| S30014001 | 9-73     | 70   | S38820000 | 95      | 57   | S52440000 | 18     | 40   | S52541001 | 4-3    | 10   |
| S30229000 | W8-6     | 52   | S39110001 | A13     | 2    | S52441000 | 19     | 40   |           | Ga1    | 76   |
| S30505001 | 13       | 20   | S39115100 | P1-21   | 28   | S52442000 | 32     | 40   | S52542001 | 4-3    | 10   |
| S31258001 | 1-1-30   | 44   |           | 1-2     | 36   | S52443000 | 25     | 40   |           | Ga1    | 76   |
| S31258001 | 1-2-30   | 46   |           | 2-1     | 36   | S52444000 | 26     | 40   | S52549001 | 47-3   | 22   |
| S31760000 | 76       | 42   | S39116100 | 1-111-2 | 32   | S52445000 | 33     | 40   | S52550001 | 41     | 16   |
| S31921000 | 9-38     | 68   |           | 1-1     | 36   | S52446000 | 36     | 40   | S52551000 | 41-1   | 16   |
| S32294001 | 1-40     | 60   |           | 18      | 36   | S52447000 | 34     | 40   | S52552000 | 42     | 16   |
| S32843001 | 32       | 8    | S39122000 | 14-3    | 70   | S52448000 | 35     | 40   | S52553000 | 43     | 16   |
| S35032101 | 1-27     | 34   | S39821000 | 100     | 32   | S52449000 | 46     | 40   | S52556000 | 45     | 16   |
| S36260000 | 1-5-2    | 54   |           | 76      | 38   | S52450000 | 43     | 40   | S52557000 | 46     | 16   |
| S36355001 | 26       | 8    |           | 210     | 58   | S52451000 | 109    | 66   | S52558000 | 47     | 16   |
| S36924001 | Wa       | 79   |           | 120     | 62   | S52452000 | 100    | 66   | S52559000 | 48     | 16   |
| S36924002 | Wa       | 79   | S39847001 | 1-26    | 34   | S52453000 | 100    | 62   | S52560001 | 41-3   | 16   |
| S37058001 | Wa       | 79   | S39901001 | 1-29    | 34   | S52454000 | 100    | 48   | S52561001 | 3-3    | 10   |
| S37059001 | Wa       | 79   | S39902001 | 1-2     | 34   | S52457000 | 27     | 40   |           | Ga1    | 75   |
| S37060001 | Wa       | 79   | S40494000 | X7      | 52   | S52458000 | 8      | 54   | S52562001 | 3-1    | 10   |
| S37968001 | 42       | 56   | S40583000 | 98      | 57   | S52459000 | 3      | 34   |           | Ga1    | 75   |
| S38059000 | 1-20     | 54   | S40616001 | 12      | 40   | S52460000 | 4      | 34   | S52563001 | 3-2    | 10   |
| S38111000 | 24       | 40   | S40620000 | 10      | 40   | S52461000 | 48     | 40   |           | Ga1    | 75   |
| S38166000 | 1-1      | 54   | S40639001 | 31-9    | 72   | S52462000 | Q1-11  | 28   | S52564001 | 3-3    | 10   |
| S38170001 | 1-4      | 54   | S40641001 | 31-18   | 72   | S52465000 | X1-1   | 52   |           | Ga1    | 75   |
| S38174000 | 1-8      | 54   | S40643001 | 31-19   | 72   | S52468000 | 102    | 70   | S52565001 | 3-3    | 10   |
| S38175001 | 1-9      | 54   | S40884000 | 1-1     | 56   | S52469000 | P1-1   | 28   |           | Ga1    | 75   |
| S38176101 | 1-10     | 54   | S41964000 | 194     | 58   | S52472001 | 5-1    | 40   | S52566001 | 3-3    | 10   |
| S38177001 | 1-14     | 54   | S42445001 | 1-1     | 60   | S52475000 | 9      | 40   |           | Ga1    | 76   |
| S38212001 | 50       | 14   |           | 21      | 66   | S52476000 | 16     | 40   | S52567001 | 3-3    | 10   |
|           | 51       | 14   | S42446001 | 1-11    | 56   | S52478000 | 14     | 40   |           | Ga1    | 76   |

| CODE      | REF.NO | Page | CODE      | REF.NO  | Page | CODE      | REF.NO | Page | CODE      | REF.NO  | Page |
|-----------|--------|------|-----------|---------|------|-----------|--------|------|-----------|---------|------|
| S52571001 | 6      | 10   | S53171000 | M1      | 26   | S53467000 | 10-2   | 12   | S53541000 | 1-1-22  | 44   |
|           | Ga1    | 75   | S53172001 | 40      | 22   |           | Ga2    | 78   |           | 1-2-22  | 46   |
| S52572001 | Ga1    | 75   | S53174001 | 36      | 8    | S53469000 | 20-2   | 12   |           | 50-10   | 48   |
| S52573001 | Ga1    | 75   | S53175000 | 129-2   | 18   |           | Ga2    | 78   |           | 51-10   | 48   |
| S52574001 | 6      | 10   | S53176000 | 129-3   | 18   | S53471000 | 10-2   | 12   | S53542000 | 50-10-3 | 48   |
|           | Ga1    | 75   | S53177000 | 129-4   | 18   |           | Ga2    | 78   |           | 51-11   | 48   |
| S52575001 | 6      | 10   | S53178000 | 129-5   | 18   | S53473000 | 20-2   | 12   | S53543001 | 1-1-23  | 44   |
|           | Ga1    | 75   | S53179000 | 129-6   | 18   |           | Ga2    | 78   |           | 1-2-23  | 46   |
| S52576001 | 6      | 10   | S53180001 | 13      | 8    | S53488000 | 28-3   | 8    | S53544001 | 1-1-24  | 44   |
|           | Ga1    | 76   | S53184001 | 145     | 18   |           | 20-2   | 24   |           | 1-2-24  | 46   |
| S52577001 | 6      | 10   | S53195000 | 61      | 16   |           | M1-2   | 26   | S53545001 | 1-1-26  | 44   |
|           | Ga1    | 76   | S53421000 | P1-5    | 28   | S53492001 | 23     | 24   |           | 1-2-26  | 46   |
| S52675902 | 23     | 14   | S53422000 | P1-7    | 28   | S53494001 | 2-2    | 24   | S53546001 | 1-1-28  | 44   |
| S52677001 | 23-2   | 14   | S53423000 | P1-6    | 28   |           | Ga1    | 75   |           | 1-2-28  | 46   |
| S52679001 | 129    | 18   | S53425001 | Q1      | 28   | S53495001 | 2-3    | 24   | S53547001 | 1-1-29  | 44   |
| S52724000 | 104    | 62   | S53426001 | Q1-1    | 28   |           | Ga1    | 75   |           | 1-2-29  | 46   |
| S52727000 | 8      | 40   | S53427001 | Q1-6    | 28   | S53496001 | 2-3    | 24   | S53548000 | 1-1-31  | 44   |
| S52732000 | 40     | 40   | S53428000 | Ga1     | 75   |           | Ga1    | 76   |           | 1-2-31  | 46   |
| S52733000 | 41     | 40   | S53429000 | 1-1-1   | 12   | S53498001 | 3-2    | 24   | S53552000 | 1-1-34  | 44   |
| S52741000 | W8-3   | 52   |           | Ga1     | 75   |           | Ga1    | 75   |           | 1-2-34  | 46   |
|           | 52     | 74   | S53430001 | 1-1-1-1 | 12   | S53501101 | 3-3    | 24   | S53553000 | 1-1-35  | 44   |
| S52744000 | 47     | 40   |           | Ga1     | 75   |           | Ga1    | 75   |           | 1-2-35  | 46   |
| S52749000 | W5     | 52   | S53430002 | 1-2-1-1 | 12   | S53503101 | 3-3    | 24   | S53554001 | 1-2     | 44   |
| S52750000 | W6     | 52   |           | Ga1     | 75   |           | Ga1    | 76   | S53555001 | 1-2-4   | 44   |
| S52751000 | W7     | 52   | S53430003 | 1-2-1-1 | 12   | S53507001 | 4-2    | 24   | S53556001 | 1-2-11  | 44   |
| S52758000 | Q1-3   | 28   |           | Ga1     | 76   |           | Ga1    | 75   | S53558001 | 1-1-1   | 44   |
| S52759000 | 100    | 70   | S53431001 | 1-1-1-2 | 12   | S53508001 | 4-3    | 24   | S53562001 | 1-2-1   | 44   |
| S52760000 | 1      | 40   |           | 1-2-1-2 | 12   |           | Ga1    | 75   | S53564001 | 1-1-2   | 44   |
| S52952001 | 29     | 40   | S53432000 | 1-1-2   | 12   | S53509001 | 4-3    | 24   |           | 1-2-2   | 44   |
| S52957000 | 1-18   | 54   | S53433000 | 1-1-3   | 12   |           | Ga1    | 76   | S53565000 | 50      | 48   |
| S52958000 | 1-19   | 54   |           | 1-2-3   | 12   | S53512101 | 7      | 24   | S53566000 | 50-1    | 48   |
| S52959000 | 1-5    | 54   | S53434000 | 1-1-4   | 12   | S53513001 | 9      | 24   |           | 51-1    | 48   |
| S52960001 | 1      | 54   |           | 1-2-4   | 12   | S53514001 | 11     | 24   | S53567001 | 50-3    | 48   |
| S52961000 | P1-2   | 28   | S53435000 | 1-2     | 12   | S53515000 | 15     | 24   |           | 51-3    | 48   |
|           | 101    | 48   |           | Ga1     | 75   | S53516000 | 15-1   | 24   | S53568001 | 50-4    | 48   |
| S52962000 | P1-3   | 28   | S53436000 | 1-2-1   | 12   | S53518001 | 1-1-6  | 12   |           | 51-4    | 48   |
|           | 102    | 48   |           | Ga1     | 75   |           | 1-2-6  | 12   | S53569001 | 50-6    | 48   |
| S52963000 | W2     | 52   | S53437000 | 1-2     | 12   | S53521001 | 2-3    | 24   | S53571001 | 50-11   | 48   |
| S52965001 | 103    | 48   |           | Ga1     | 76   |           | Ga1    | 75   |           | 51-12   | 48   |
| S52966000 | Q1-2   | 28   | S53438000 | 1-2-1   | 12   | S53522101 | 3-3    | 24   | S53572001 | 50-12   | 48   |
| S52968001 | 5-2    | 40   |           | Ga1     | 76   |           | Ga1    | 75   |           | 51-13   | 48   |
| S52970000 | 97     | 57   | S53445000 | 10-2    | 12   | S53523001 | 4-3    | 24   | S53573001 | 50-14   | 48   |
| S52973000 | 70     | 38   |           | Ga2     | 77   |           | Ga1    | 75   |           | 51-15   | 48   |
| S52974000 | 120    | 66   | S53449000 | 20-2    | 12   | S53531000 | 1      | 44   | S53574000 | 50-15   | 48   |
| S52975001 | 1      | 54   |           | Ga2     | 77   | S53532001 | 1-1    | 44   |           | 51-16   | 48   |
| S52976000 | 1-1    | 54   | S53451000 | 10-2    | 12   | S53533001 | 1-1-4  | 44   | S53575001 | 50-16   | 48   |
| S52977000 | 1-1-2  | 54   |           | Ga2     | 77   | S53534100 | 1-1-8  | 44   |           | 51-17   | 48   |
| S52978000 | 1-1-3  | 54   | S53453000 | 20-2    | 12   |           | 1-2-8  | 44   | S53576001 | 50-19   | 48   |
| S52979000 | 1-2    | 54   |           | Ga2     | 77   | S53535001 | 1-1-10 | 44   |           | 51-20   | 48   |
| S52980000 | 2      | 54   | S53455000 | 10-2    | 12   |           | 1-2-10 | 44   | S53577000 | 50-21   | 48   |
| S52985000 | X10    | 52   |           | Ga2     | 77   | S53536001 | 1-1-11 | 44   |           | 51-22   | 48   |
| S52986000 | 102    | 62   | S53457000 | 20-2    | 12   | S53537001 | 1-1-12 | 44   | S53580001 | 50-22   | 48   |
| S52989000 | X1     | 52   |           | Ga2     | 77   |           | 1-2-12 | 44   |           | 51-23   | 48   |
| S52991000 | 12     | 32   | S53459000 | 10-2    | 12   | S53538101 | 1-1-15 | 44   | S53581000 | 51      | 48   |
| S53000001 | W1     | 52   |           | Ga2     | 77   |           | 1-2-15 | 44   | S53582001 | 51-6    | 48   |
| S53007001 | W8     | 52   | S53461000 | 20-2    | 12   | S53539001 | 1-1-17 | 44   | S53583000 | 107     | 50   |
| S53010001 | 1-6    | 54   |           | Ga2     | 77   |           | 1-2-17 | 44   | S53584000 | 108     | 50   |
| S53166000 | N8     | 26   | S53463000 | 10-2    | 12   | S53540001 | 1-1-19 | 44   | S53585001 | 109     | 50   |
| S53167000 | 29     | 8    |           | Ga2     | 77   |           | 1-2-19 | 44   | S53586001 | 111     | 50   |
| S53168000 | 28-2   | 8    | S53465000 | 20-2    | 12   |           | 50-7   | 48   | S53588000 | 105     | 48   |
| S53169001 | 34     | 8    |           | Ga2     | 77   |           | 51-7   | 48   | S53617000 | P1-10   | 28   |

## 索引 / INDEX

| CODE      | REF.NO | Page | CODE      | REF.NO | Page | CODE      | REF.NO | Page | CODE      | REF.NO   | Page |
|-----------|--------|------|-----------|--------|------|-----------|--------|------|-----------|----------|------|
| S53618000 | P1-11  | 28   | S53734000 | 1-39-2 | 60   | S53963000 | 24     | 36   | S54665000 | 20-2     | 12   |
| S53624001 | 1-2    | 56   | S53742001 | 1-1    | 64   | S53964000 | 35     | 36   |           | Ga2      | 77   |
| S53625001 | 1-6    | 56   | S53743000 | 1-10   | 64   | S53965000 | 36     | 36   | S54667000 | 10-2     | 12   |
| S53626001 | 1-8    | 56   | S53744001 | 1-12   | 64   | S53973000 | 56     | 38   |           | Ga2      | 77   |
| S53627101 | 2      | 56   | S53745000 | 1-18   | 64   | S53978000 | P1-12  | 28   | S54669000 | 20-2     | 12   |
| S53628001 | 6      | 56   | S53747000 | 1-20   | 64   | S53981000 | 1-44-2 | 30   |           | Ga2      | 77   |
| S53629000 | 11     | 56   | S53748001 | 1-21   | 64   |           | 1-59-2 | 30   | S54671000 | 10-2     | 12   |
| S53633001 | 1-12   | 56   | S53749000 | 1-23   | 64   |           | 1-4    | 36   |           | Ga2      | 78   |
| S53634001 | 1-13   | 56   | S53750001 | 1-26   | 64   | S53982000 | 1-3    | 36   | S54673000 | 20-2     | 12   |
| S53635001 | 1-14   | 56   | S53751001 | 1-29   | 64   |           | 2-2    | 36   |           | Ga2      | 78   |
| S53636001 | 1-21   | 56   | S53752001 | 1-31   | 64   | S53983000 | P1-22  | 28   | S54675000 | 10-2     | 12   |
| S53637001 | 1-22   | 56   | S53753000 | 1-34   | 64   |           | 1-5    | 36   |           | Ga2      | 78   |
| S53638000 | 31     | 56   | S53754000 | 1-34-1 | 64   | S53985000 | 5-5    | 36   | S54677000 | 20-2     | 12   |
| S53639001 | 35     | 56   | S53756001 | 1-36   | 64   |           | 13     | 36   |           | Ga2      | 78   |
| S53640001 | 38     | 56   | S53757001 | 1-37   | 64   | S53989000 | 50-17  | 48   | S54993001 | 200      | 18   |
|           | 9-25   | 68   | S53758001 | 1-39   | 64   |           | 51-18  | 48   | S55009000 | 47       | 36   |
| S53643001 | 44     | 56   | S53759001 | 1-41   | 64   | S54022001 | 30     | 72   | S55010000 | 48       | 36   |
| S53644001 | 48     | 56   | S53760000 | 1-43   | 64   | S54023001 | 8      | 20   | S55013000 | 50       | 38   |
| S53645001 | 49     | 56   | S53773001 | 1-50   | 64   | S54104000 | 57     | 38   | S55300101 | 2        | 36   |
| S53646000 | 53     | 56   | S53774001 | 1-52   | 64   | S54106001 | 1-57   | 30   | S55302000 | 125      | 62   |
| S53647000 | 54     | 56   | S53775001 | 1-56   | 64   | S54108001 | 1-32   | 30   | S55303000 | 79       | 38   |
| S53648001 | 55     | 56   | S53776000 | 4      | 66   | S54115001 | 1-2    | 30   | S55304000 | 203      | 18   |
| S53649001 | 59     | 56   | S53777001 | 10     | 66   | S54117001 | 1-33   | 30   | S55305000 | 126      | 62   |
| S53650000 | 62     | 57   | S53779001 | 13     | 66   |           | 157    | 57   | S55308001 | 166      | 57   |
| S53651001 | 62-1   | 57   | S53780001 | 15     | 66   | S54118001 | 1-45   | 30   | S55310001 | 100      | 57   |
| S53652001 | 64     | 57   | S53781001 | 19     | 66   | S54119001 | 1-56   | 30   | S55454001 | 1-1-33   | 44   |
| S53653000 | 66     | 57   | S53782001 | 22     | 66   | S54120001 | 1-52   | 30   | S55455001 | 1-2-33   | 46   |
| S53654001 | 69     | 57   | S53783001 | 1-59   | 64   | S54122001 | 1-28   | 30   | S55476001 | 2        | 40   |
| S53655001 | 70     | 57   | S53784000 | 122    | 66   | S54123001 | 1-27   | 30   | S55479001 | 191      | 58   |
| S53656000 | 74     | 57   | S53785001 | 1-6    | 64   | S54126001 | 1-48   | 30   | S55484001 | 6        | 36   |
| S53659000 | 81     | 57   | S53786000 | 1-34-2 | 64   | S54127001 | 1-49   | 30   | S55485001 | 12       | 56   |
| S53660000 | 83     | 57   | S53787001 | 1-15   | 64   | S54130001 | 1-80   | 30   |           | 71       | 57   |
| S53661000 | 87     | 57   | S53792001 | 9-1    | 68   | S54132001 | 1-99   | 30   | S55486001 | 88       | 57   |
| S53671000 | 150    | 57   | S53793001 | 9-2    | 68   | S54133001 | 1-100  | 30   | S55488001 | 20       | 66   |
| S53672000 | 152    | 57   | S53794001 | 9-5    | 68   | S54135000 | 1-44-3 | 30   | S55571001 | 1        | 36   |
| S53673000 | 153    | 57   | S53795001 | 9-9    | 68   | S54136000 | 1-44-1 | 30   | S55663001 | 21       | 74   |
| S53674000 | 155    | 57   | S53798001 | 9-18   | 68   | S54137000 | 1-44   | 30   | S55769000 | 201      | 18   |
| S53675001 | 162    | 57   | S53799000 | 9-21   | 68   | S54140001 | 1-43   | 30   |           | 202      | 18   |
| S53676001 | 164    | 57   | S53800001 | 9-24   | 68   | S54592000 | 1-59-1 | 30   | S55770000 | 24       | 16   |
| S53677000 | 170    | 57   | S53801001 | 9-26   | 68   | S54594000 | 1-60   | 30   |           | 25       | 16   |
| S53678001 | 170-1  | 57   | S53802001 | 9-32   | 68   | S54595000 | 1-53   | 30   | S55896001 | 39       | 8    |
| S53679000 | 171    | 57   | S53803001 | 9-34   | 68   | S54596000 | 1-41   | 30   | S55898000 | 150      | 18   |
| S53680000 | 172    | 57   | S53804001 | 9-41   | 68   | S54602000 | 1-117  | 32   | S56006000 | 2-1      | 46   |
| S53681000 | 173    | 57   | S53805001 | 9-47   | 68   | S54605000 | 1-105  | 32   | S56007000 | 2-2      | 46   |
| S53682001 | 174    | 58   | S53806001 | 9-51   | 68   | S54614000 | 53     | 38   | S56008000 | 2-3      | 46   |
| S53683001 | 175    | 58   | S53815001 | 12     | 70   | S54615000 | 54     | 38   | S56009000 | 2-4      | 46   |
| S53684001 | 190    | 58   | S53816100 | 14     | 70   |           | 55     | 38   | S56010000 | 2-5      | 46   |
| S53685001 | 67     | 57   | S53817100 | 14-1   | 70   | S54651000 | 10-2   | 12   | S56861001 | 1-46     | 64   |
| S53686001 | 18     | 70   | S53818001 | 16     | 70   | S54651000 | Ga2    | 77   | S56862001 | 1-48     | 64   |
| S53689001 | 200    | 58   | S53819000 | 9-11-3 | 68   | S54653000 | 20-2   | 12   | S56868000 | 5        | 36   |
| S53690001 | 202    | 58   | S53820000 | 9-11-2 | 68   |           | Ga2    | 77   | S56869000 | 5-3      | 36   |
| S53691001 | 168    | 57   | S53917000 | 101    | 66   | S54655000 | 30-2   | 12   | S56870001 | 11       | 66   |
| S53700000 | 1      | 60   | S53951000 | 49     | 36   |           | Ga2    | 77   | S57533000 | 1-1-33-1 | 44   |
| S53702000 | 1-2    | 60   | S53952000 | 43     | 36   | S54657000 | 20-2   | 12   |           | 1-2-33-1 | 46   |
| S53703000 | 1-16   | 60   |           | 52     | 38   |           | Ga2    | 77   |           | 40       | 74   |
| S53705001 | 1-26   | 60   | S53954000 | 51     | 38   | S54659000 | 50-2   | 12   | S57535000 | 19       | 4    |
| S53706001 | 1-29   | 60   | S53958000 | 33     | 36   |           | Ga2    | 77   | S57538001 | 1-9      | 56   |
| S53707001 | 1-31   | 60   | S53959000 | 34     | 36   | S54661000 | 20-2   | 12   | S57539001 | 1-10     | 56   |
| S53708001 | 1-36   | 60   | S53960000 | 21     | 36   |           | Ga2    | 77   | S57541001 | 20       | 60   |
| S53709000 | 1-39   | 60   | S53961000 | 22     | 36   | S54663000 | 10-2   | 12   | S57620001 | X4       | 52   |
| S53710000 | 1-39-1 | 60   | S53962000 | 23     | 36   |           | Ga2    | 77   | S57937000 | 9-11     | 68   |



| CODE      | REF.NO  | Page | CODE      | REF.NO | Page | CODE      | REF.NO  | Page | CODE | REF.NO | Page |
|-----------|---------|------|-----------|--------|------|-----------|---------|------|------|--------|------|
| S57938000 | 9-11-1  | 68   | S59217000 | 9      | 36   | S59297000 | Ga1     | 76   |      |        |      |
| S57942000 | X1-2    | 52   | S59218000 | 9-1    | 36   | S59298000 | 20      | 12   |      |        |      |
| S58034000 | 45      | 36   | S59219000 | 5-4    | 36   |           | Ga1     | 76   |      |        |      |
| S58035000 | 39      | 36   |           | 9-2    | 36   | S59338001 | 34      | 74   |      |        |      |
| S58036000 | 40      | 36   | S59220000 | 9-3    | 36   | S59350001 | 35      | 74   |      |        |      |
| S58037000 | 37      | 36   | S59235001 | 1      | 24   | S59357001 | N5      | 26   |      |        |      |
| S58038000 | 38      | 36   | S59271000 | 10     | 12   | S59368000 | 1-111-3 | 32   |      |        |      |
| S58039000 | 25      | 36   |           | Ga1    | 75   | S59371001 | P1      | 28   |      |        |      |
| S58040000 | 26      | 36   | S59272000 | 10     | 12   | S59372000 | 2-3     | 36   |      |        |      |
| S58179001 | 1       | 30   |           | Ga1    | 75   | S59387000 | 1-118   | 32   |      |        |      |
| S58180001 | 1-1     | 30   | S59273000 | 20     | 12   | W01519001 | 10-3    | 12   |      |        |      |
| S58181001 | 1-64    | 30   |           | Ga1    | 75   |           | 20-3    | 12   |      |        |      |
| S58182100 | 1-65    | 30   | S59274000 | 20     | 12   |           | 30-3    | 12   |      |        |      |
| S58183000 | 1-111   | 32   |           | Ga1    | 75   |           | 50-3    | 12   |      |        |      |
| S58184000 | 1-111-1 | 32   | S59275000 | 10     | 12   | XA2220050 | 1-9     | 54   |      |        |      |
| S58204001 | 1-1-18  | 44   |           | 30     | 12   |           |         |      |      |        |      |
|           | 1-2-18  | 44   |           | Ga1    | 75   |           |         |      |      |        |      |
| S58594000 | 9-43    | 68   | S59276000 | 10     | 12   |           |         |      |      |        |      |
| S58675000 | 1-1     | 12   |           | Ga1    | 75   |           |         |      |      |        |      |
| S58692001 | 9-70    | 70   | S59277000 | 20     | 12   |           |         |      |      |        |      |
| S58693000 | 13      | 32   |           | Ga1    | 75   |           |         |      |      |        |      |
| S58900000 | 3       | 46   | S59278000 | 20     | 12   |           |         |      |      |        |      |
| S58903000 | 2-6     | 46   |           | Ga1    | 75   |           |         |      |      |        |      |
| S59031000 | 1-59    | 30   | S59279000 | 10     | 12   |           |         |      |      |        |      |
| S59032000 | 5       | 24   |           | 50     | 12   |           |         |      |      |        |      |
| S59033000 | 9-69    | 70   |           | Ga1    | 75   |           |         |      |      |        |      |
| S59034000 | 9-68    | 70   | S59280000 | 10     | 12   |           |         |      |      |        |      |
| S59035000 | 9-59    | 70   |           | Ga1    | 75   |           |         |      |      |        |      |
| S59036001 | 21      | 24   | S59281000 | 20     | 12   |           |         |      |      |        |      |
| S59041000 | 10-1    | 12   |           | Ga1    | 75   |           |         |      |      |        |      |
|           | 30-1    | 12   | S59282000 | 20     | 12   |           |         |      |      |        |      |
|           | 50-1    | 12   |           | Ga1    | 75   |           |         |      |      |        |      |
| S59042000 | 20-1    | 12   | S59283000 | 10     | 12   |           |         |      |      |        |      |
| S59043001 | 9-62    | 70   |           | Ga1    | 75   |           |         |      |      |        |      |
| S59044001 | 9-61    | 70   | S59284000 | 10     | 12   |           |         |      |      |        |      |
| S59045001 | 1-3     | 6    |           | Ga1    | 75   |           |         |      |      |        |      |
| S59046001 | 9-53    | 68   | S59285000 | 20     | 12   |           |         |      |      |        |      |
| S59047001 | 9-85    | 70   |           | Ga1    | 75   |           |         |      |      |        |      |
| S59048001 | 9-56    | 68   | S59286000 | 20     | 12   |           |         |      |      |        |      |
| S59139001 | 1-3     | 10   |           | Ga1    | 75   |           |         |      |      |        |      |
|           | Ga1     | 75   | S59287000 | 10     | 12   |           |         |      |      |        |      |
| S59140001 | 1-1     | 10   |           | Ga1    | 75   |           |         |      |      |        |      |
|           | Ga1     | 75   | S59288000 | 10     | 12   |           |         |      |      |        |      |
| S59141001 | 1-2     | 10   |           | Ga1    | 75   |           |         |      |      |        |      |
|           | Ga1     | 75   | S59289000 | 20     | 12   |           |         |      |      |        |      |
| S59142001 | 1-3     | 10   |           | Ga1    | 75   |           |         |      |      |        |      |
|           | Ga1     | 75   | S59290000 | 20     | 12   |           |         |      |      |        |      |
| S59143001 | 1-3     | 10   |           | Ga1    | 75   |           |         |      |      |        |      |
|           | Ga1     | 75   | S59291000 | 10     | 12   |           |         |      |      |        |      |
| S59144001 | 1-3     | 10   |           | Ga1    | 76   |           |         |      |      |        |      |
|           | Ga1     | 76   | S59292000 | 10     | 12   |           |         |      |      |        |      |
| S59145001 | 1-3     | 10   |           | Ga1    | 76   |           |         |      |      |        |      |
|           | Ga1     | 76   | S59293000 | 20     | 12   |           |         |      |      |        |      |
| S59149001 | 18      | 8    |           | Ga1    | 76   |           |         |      |      |        |      |
| S59150001 | 22      | 8    | S59294000 | 20     | 12   |           |         |      |      |        |      |
| S59151001 | 24      | 8    |           | Ga1    | 76   |           |         |      |      |        |      |
| S59152001 | 23      | 8    | S59295000 | 10     | 12   |           |         |      |      |        |      |
|           | 16      | 72   |           | Ga1    | 76   |           |         |      |      |        |      |
| S59155000 | 20      | 24   | S59296000 | 10     | 12   |           |         |      |      |        |      |
| S59156000 | 20-1    | 24   |           | Ga1    | 76   |           |         |      |      |        |      |
| S59158001 | 22      | 24   | S59297000 | 20     | 12   |           |         |      |      |        |      |

brother®

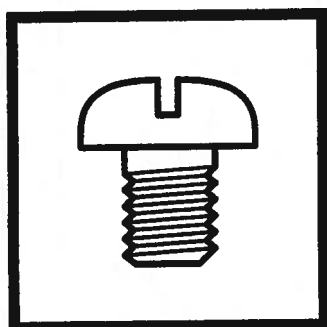

パーツブック  
PARTS BOOK

**ブラザー工業株式会社**

〒467-8561 名古屋市瑞穂区苗代町 15 番 1 号 TEL (052) 824-2392

**BROTHER INDUSTRIES, LTD**

15-1, Naeshiro-cho, Mizuho-ku, Nagoya 467-8561, Japan. Phone : 81-52-824-2177

Printed in Japan

151-615  
S98615-001  
2001.11. F (1)