

BAS-7050

パーツブック
PARTS BOOK
TEILEKATALOG
LIVRE DES PIECES
LIBRO DE REFERENCIA DE PIEZAS

2本針自動ベルトループ付けミシン

AUTOMATIC TWIN NEEDLE BELT LOOP SEWER

ZWEINADEL GÜRTELSCHLAUFEN AUFNÄH -AUTOMAT

POSE PASSANTS AUTOMATIQUE - 2 AIGUILLES

COSEDORA AUTOMATICA DE PASADORES CON DOS AGUJAS

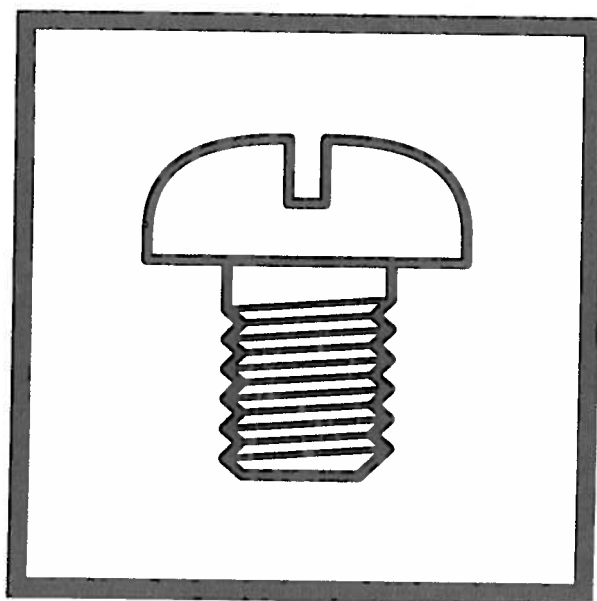

brother®



パーツブックご利用に際して

1. この本は、1998年5月のデータに基づいて作成されたものです。
2. 部品は予告なしに設計変更される場合があります。
3. 組単位で補給する部品は、[]破線で示しております。
4. 部品コード欄が※となっている場合は、ゲージ部品一覧表(75ページ)でお調べ下さい。

目 次

A1. 主体関係	1	N. 針位置検出器関係	47
A2. 主体関係	3	P. コントロールボックス関係	49
B. 上軸・針棒関係	7	Q. 空圧関係	51
C1. 送り関係	9	R1. 電装品関係	55
C2. 送り関係	11	R2. 電装品関係	61
D1. フィーダー関係	13	S. 付属装置関係 (オプション部品)	61
D2. フィーダー関係	15	T. プリント基板関係	63
D3. フィーダー関係	19	U. 頭部部品関係	63
D4. フィーダー関係	23	V. 動力台関係	65
D5. フィーダー関係 (オプション部品)	27	W1. 付属装置関係 (オプション部品)	67
E. 下軸関係	29	W2. 付属装置関係 (オプション部品)	69
F. 下軸モジュール関係	31	Z. 付属品関係	71
G1. 給油潤滑関係	35	Ga. ゲージ部品一覧表	75
G2. 給油潤滑関係	37	Wa1. 警告ラベル	77
H. 糸払い関係	37	Wa2. 警告ラベル	78
J. 糸通シ関係	39	索引	79
K. 糸巻関係	41		
L. 糸切り関係	43		
M. 糸締め関係	47		

Notes for using this parts book

1. This book was prepared based on information available in May 1998.
2. Parts are subject to changes in design without prior notice.
3. Parts supplied as complete assemblies are circled by a dotted line [] .
4. If the symbol ※ is found in the "Parts No." column, refer to the gauge parts list on page 75.

CONTENTS

A1 . Machine body	1	M . Thread nipper mechanism	47
A2 . Machine body	3	N . Synchronizer	47
B . Upper shaft and needle bar mechanism	7	P . Control box mechanism	49
C1 . Feed mechanism	9	Q . Air pressure mechanism	51
C2 . Feed mechanism	11	R1 . Power supply equipment mechanism ...	55
D1 . Feeder mechanism	13	R2 . Power supply equipment mechanism ...	61
D2 . Feeder mechanism	15	S . Attachment set (Option parts)	61
D3 . Feeder mechanism	19	T . Printed circuit board mechanism	63
D4 . Feeder mechanism	23	U . Machine head parts	63
D5 . Feeder mechanism (Option parts)	27	V . Power table	65
E . Lower shaft mechanism	29	W1 . Attachment set (Option parts)	67
F . Lower shaft module mechanism	31	W2 . Attachment set (Option parts)	69
G1 . Lubrication	35	Z . Accessories	71
G2 . Lubrication	37	Ga . Gauge parts List	75
H . Thread wiper mechanism	37	Wa1 . Warning labels	77
J . Threading mechanism	39	Wa2 . Warning labels	78
K . Bobbin winder mechanism	41	Index	79
L . Thread trimmer mechanism	43		

Hinweise zur Verwendung dieser Teileliste

1. Dieses Buch basiert auf den Informationen vom Mai 1998.
2. Modelländerungen sind vorbehalten.
3. Die Teile, die als kompletter Satz geliefert werden, sind mit einer gestrichelten Linie umrandet.
4. Dieses Zeichen ※ in der Spalte "Parts No. (Teil-nummer)" verweist auf die Lehrenliste auf Seite 75.

INHALTSVERZEICHNIS

A1 . Maschinengehäuse	1	M . Fadenspannvorrichtung	47
A2 . Maschinengehäuse	3	N . Synchronisator	47
B . Obere Welle und Nadelstangenvorrichtung	7	P . Schaltkasten	49
C1 . Transportvorrichtung	9	Q . Luftdruck	51
C2 . Transportvorrichtung	11	R1 . Stromversorgung	55
D1 . Knopfsortierer	13	R2 . Stromversorgung	61
D2 . Knopfsortierer	15	S . Anbausatz (Sonderzubehör)	61
D3 . Knopfsortierer	19	T . Leiterplatten	63
D4 . Knopfsortierer	23	U . Teile des maschinenoberteils	63
D5 . Knopfsortierer (Sonderzubehör)	27	V . Motorgestell	65
E . Untere Welle	29	W1 . Anbausatz (Sonderzubehör)	67
F . Module für untere Welle	31	W2 . Anbausatz (Sonderzubehör)	69
G1 . Schmierung	35	Z . Zubehör	71
G2 . Schmierung	37	Ga . Lehrenliste	75
H . Fadenwischvorrichtung	37	Wa1 . Warnschilder	77
J . Fadenführungsvorrichtung	39	Wa2 . Warnschilder	78
K . Spuler	41	Verzeichnis	79
L . Fadenabschneidevorrichtung	43		

Notes sur l'utilisation de ce manuel de pièces détachées

1. Ce manuel a été fait d'après les renseignements valables au mois de Mai 1998.
2. Les pièces peuvent être sujettes à des modifications sans préavis.
3. Les pièces fournies en tant qu'assemblages complets sont encadrées avec un trait pointillé [] .
4. Si le symbole ※ se trouve dans la colonne "Parts No. (N° de pièce)" veuillez la Liste des Pièces decartment annexe page 75.

TABLE DES MATIERES

A1 . Corps de la machine	1	M . Mécanisme de pince-fil	47
A2 . Corps de la machine	3	N . Synchronisateur	47
B . Mécanisme de arbre supérieur et barra à aiguille	7	P . Mécanisme du boîtier de contrôle	49
C1 . Mécanisme de l'entraînement	9	Q . Mécanisme de la pression d'air	51
C2 . Mécanisme de l'entraînement	11	R1 . Mécanisme de l'équipement en alimentation électrique	55
D1 . Tricur de boutons	13	R2 . Mécanisme de l'équipement en alimentation électrique	61
D2 . Tricur de boutons	15	S . Jeu d'accessoires (Pièces en option)	61
D3 . Tricur de boutons	19	T . Circuits imprimés	63
D4 . Tricur de boutons	23	U . Pièces supérieures de la machine	63
D5 . Tricur de boutons (Pièces en option)	27	V . Mécanisme du plateau de la machine	65
E . Mécanisme de l'arbre inférieur	29	W1 . Jeu d'accessoires (Pièces en option)	67
F . Mécanisme de module d' arbre inférieur	31	W2 . Jeu d'accessoires (Pièces en option)	69
G1 . Lubrification	35	Z . Accessoires	71
G2 . Lubrification	37	Ga . Liste des Pièces decartment	75
H . Mécanisme de tire-fil	37	Wa1 . Etiquettes d'avertissement	77
J . Mécanisme de l'enfilage	39	Wa2 . Etiquettes d'avertissement	78
K . Mécanisme du bobineur	41	Index	79
L . Mécanisme de coupe-fil	43		

Notas para usar este Manual de Piezas

1. Este libro ha sido compilado basándose en los datos de que se disponía en mayo 1998.
2. Las piezas quedan sujetas a cambios de diseño sin aviso previo.
3. Las piezas suministradas como conjuntos completos se enmarcan con una línea punteada [-----] .
4. De haber un símbolo ※ junto al "Parts No. (Número de Pieza)", habrá que mirar la lista de piezas separada de la página 141.

INDICE

A1 . Cuerpo de la máquina	1	M . Mecanismo de la mordaza para hilo	47
A2 . Cuerpo de la máquina	3	N . Sincronizador	47
B . Mecanismo del eje superior y la barra de aguja	7	P . Mecanismo de la caja de controles	49
C1 . Mecanismo de la alimentación	9	Q . Mecanismo de la presión de aire	51
C2 . Mecanismo de la alimentación	11	R1 . Mecanismo del equipo de alimentación de corriente	55
D1 . Mecanismo de botones	13	R2 . Mecanismo del equipo de alimentación de corriente	61
D2 . Mecanismo de botones	15	S . Juego de fijación (Piezas opcionales) ...	61
D3 . Mecanismo de botones	19	T . Tableros de circuitos impresos	63
D4 . Mecanismo de botones	23	U . Piezas de la cabeza de la máquina	63
D5 . Mecanismo de botones (Piezas opcionales)	27	V . Mecanismo de la mesa de la máquina ..	65
E . Mecanismo del eje inferior	29	W1 . Juego de fijación (Piezas opcionales) ...	67
F . Mecanismo de módulo de eje inferior ...	31	W2 . Juego de fijación (Piezas opcionales) ...	69
G1 . Lubricación	35	Z . Accesorios	71
G2 . Lubricación	37	Ga . Lista d'ePiezas de calibradores	75
H . Mecanismo del limpiador de hilo	37	Wa1 . Etiquetas de advertencia	77
J . Mecanismo del enhebrado	39	Wa2 . Etiquetas de advertencia	78
K . Mecanismo del devanador de la canilla	41	Indice	79
L . Mecanismo de la cortadura de hiros	43		

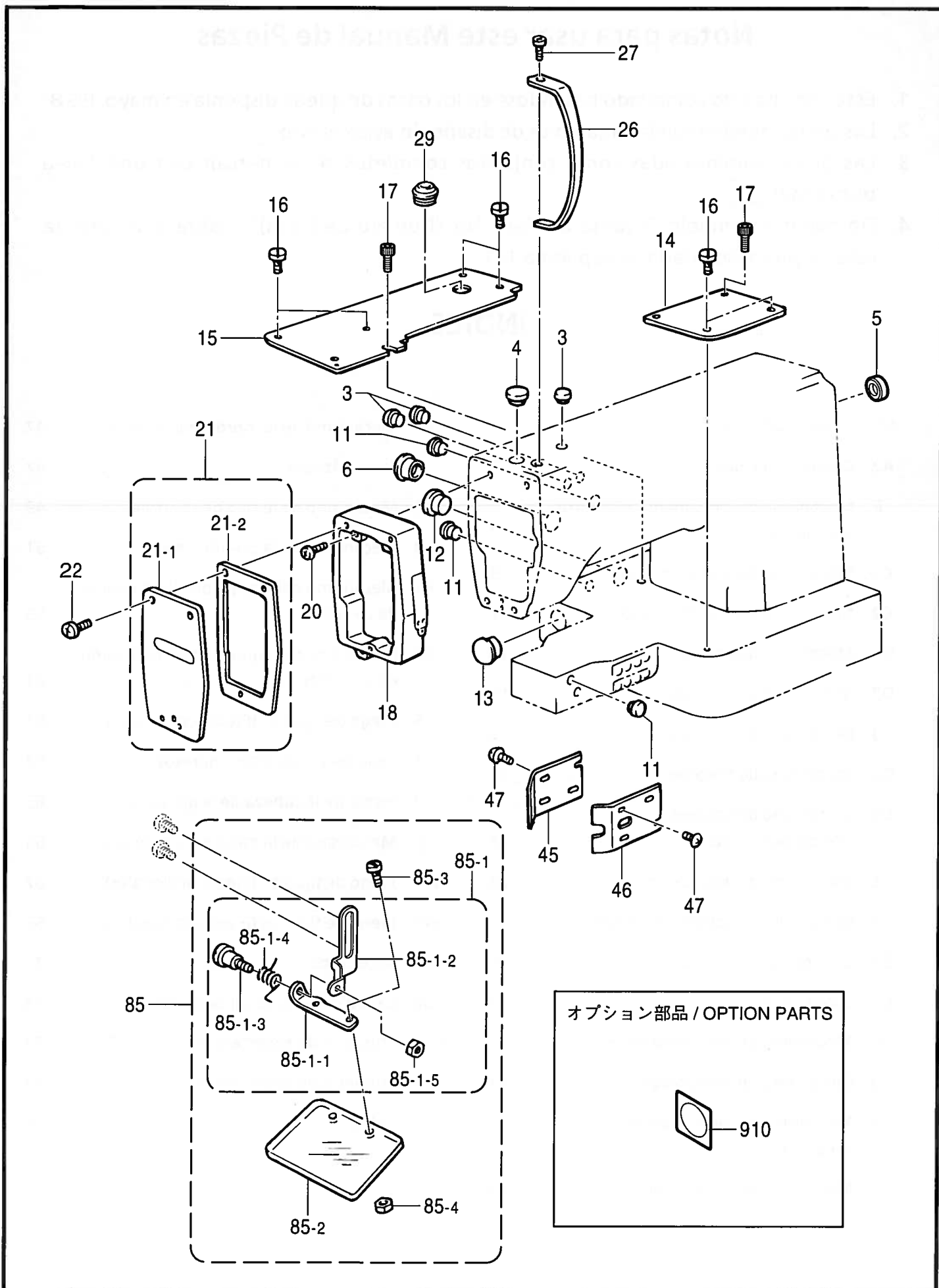

A1 . 主体関係 / Machine body / Maschinengehäuse / Corps de la machine / Cuerpo de la máquina

REF.NO.	CODE	Q'TY	品名	NAME OF PARTS	RM
3	104450109	3	ゴムセン8	RUBBER CAP, 8	
4	159928009	1	ゴムセン15	RUBBER CAP, 15	
5	S20164009	1	ゴムセン13	RUBBER CAP, 13	
6	140392009	1	オイルフタ	OIL CAP	
11	104450109	3	ゴムセン8	RUBBER CAP, 8	
12	104449009	1	ゴムセン15.5	RUBBER CAP, 15.5	
13	140392009	1	オイルフタ	OIL CAP	
14	S37915009	1	ベッドカバーR	BED COVER, R	
15	S41675109	1	ベッドカバーL	BED COVER, L	
16	106629002	6	シメネジ4.37	SCREW, SM4.37	
17	018680522	2	アナボルト4.37X5	BOLT, SOCKET SM4.37X5	
18	S41669009	1	アームスパーサ	ARM SPACER	
20	062711212	3	ナベコ476-32X12	SCREW, PAN SM4.76-32X12	
21	S41670009	1	メンイタクミ	FACE PLATE ASSY	
21-1	S41671009	1	メンイタ	FACE PALTE	
21-2	S41672000	1	メンイタガワハツキン	PACKING	
22	062401012	3	ナベコM4X10	SCREW, PAN M4X10	
26	S37920009	1	テンビンカバー	THREAD TAKE-UP COVER	
27	062680612	1	ナベコ4.37-40X6	SCREW, PAN SM4.37-40X6	
29	S42227009	1	グロメツトMG-3	RUBBER CAP, MG-3	
45	S41763009	1	サイドカバーL	SIDE COVER, L	
46	S41764009	1	サイドカバーR	SIDE COVER, R	
47	008300604	8	+トラスコ3X6	SCREW, TRUSS M3X6	
85	S41673001	1	アイガードクミ	EYE GUARD ASSY	
85-1	S41733001	1	アイガードトリツケイタクミ	EYE GUARD SETTING PLATE ASSY	
85-1-1	S34844001	1	アイガードトリツケイタ	EYE GUARD SETTING PLATE	
85-1-2	S41709001	1	アイガードドダイ	EYE GUARD BASE	
85-1-3	S36071001	1	アイガードシテンネジ	EYE GUARD SCREW	
85-1-4	S36070001	1	アイガードモドシバネ	SPRING, EYE GUARD	
85-1-5	106129002	1	ナツト3.57	NUT, SM3.57	
85-2	S41674000	1	アイガード	EYE GUARD	
85-3	100257010	2	シメネジ3.57	SCREW, SM3.57	
85-4	106129002	2	ナツト3.57	NUT, SM3.57	
910	S37057001	1	オプション部品" EMスイッチスパーサ3	" OPTION PARTS " EM SWITCH SPACER, 3	

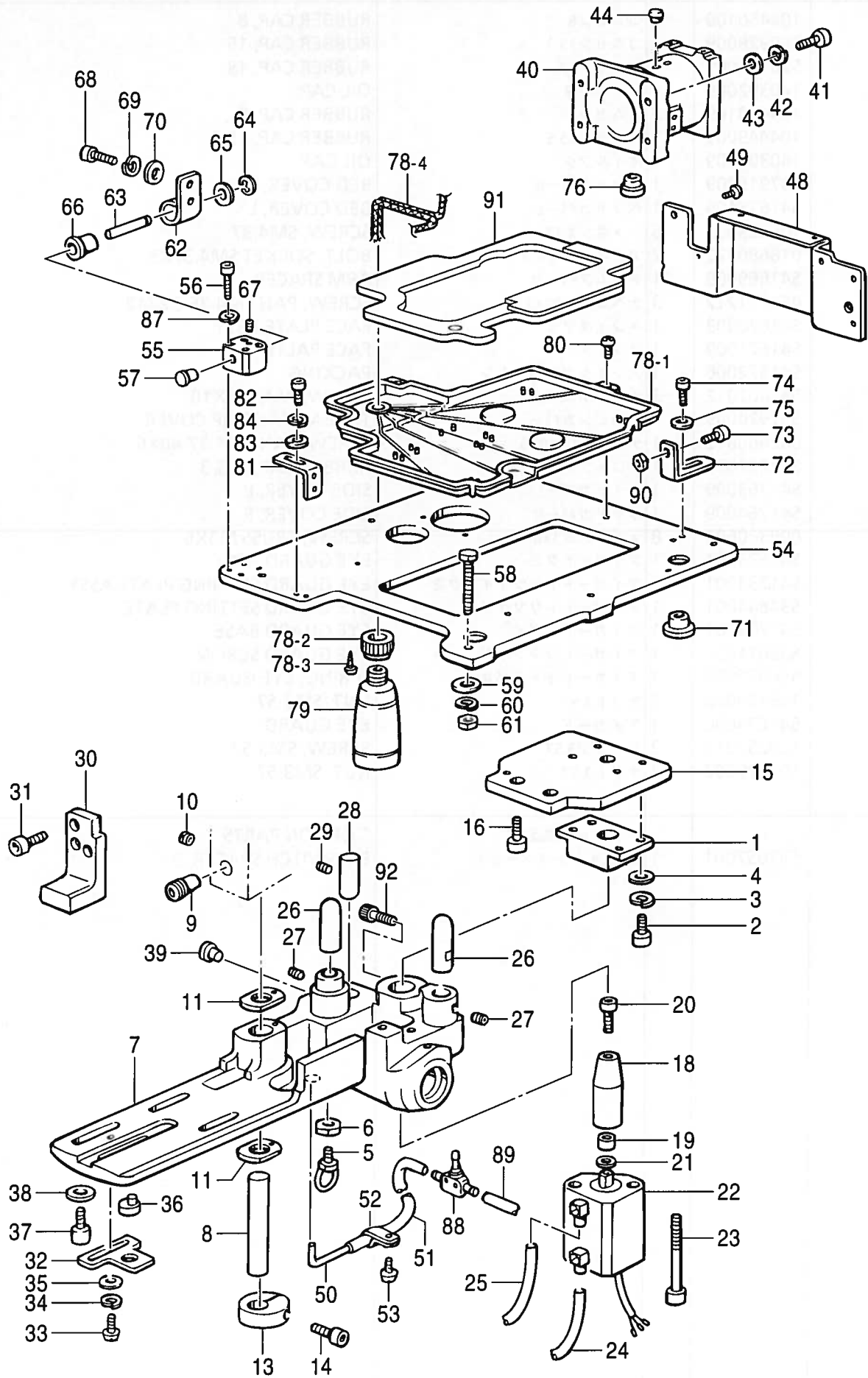

A2 . 主体関係 / Machine body / Maschinengehäuse / Corps de la machine / Cuerpo de la máquina

REF.NO.	CODE	Q'TY	ヒンメイ	NAME OF PARTS	RM
1	S41745001	1	イチギメジクウケ	POSITIONING BEARING	
2	018501236	4	アナボルト5X12	BOLT, SOCKET M5X12	
3	028050246	4	バネザガネ2-5	WASHER, SPRING 2-5	
4	025050236	4	ヒラザガネチユウ5	WASHER, PLAIN M 5	
5	S41746000	1	アイボルト	EYE BOLT	
6	021060206	1	2シユナツト6	NUT, 2 M6	
7	S41747009	1	BMササエダイ	BM SUPPORT BASE	
8	S41748001	1	BMササエシテンジク	BM SUPPORT FULCRUM SHAFT	
9	149996001	1	ストツブカムセットネジ	STOP CAM SET SCREW	
10	105299002	1	トメネジ6.35	SET SCREW, SM6.35	
11	S41749001	2	スラストザガネ16	WASHER, THRUST 16	
13	S41750001	1	カラー16	COLLAR, 16	
14	018061636	1	アナボルト6X16	BOLT, SOCKET M6X16	
15	S41751001	1	ソコイタ	BOTTOM PLATE	
16	018501036	3	アナボルト5X10	BOLT, SOCKET M5X10	
18	S41752001	1	BMササエスライドジク	BM SUPPORT SLIDE SHAFT	
19	S41753001	1	スパーサ5.6	SPACER, 5.6	
20	018061636	1	アナボルト6X16	BOLT, SOCKET M6X16	
21	S03695001	1	ザガネ6	WASHER, PLAIN 6	
22	S41754000	1	スライドシリンダクミ	SLIDE CYLINDER ASSY	
23	S14473000	2	CQ2ボルトM5X60	BOLT, CQ2 M5X60	
24	S41940000	1	エアホース0425S124B	AIR TUBE, 0425S (L = 1240)	
25	S18387004	1	エアチューブ	AIR TUBE, 4 (L = 1300)	
26	S41757001	2	BMササエダイスベリジク	BM SUPPORT BASE SLIDE SHAFT	
27	012060636	4	アナヒラ6X6	SET SCREW, SOCKET (FT) M6X6	
28	S41758001	1	BMササエスベリジク	SLIDE SHAFT, BM SUPPORT (R)	
29	012060636	2	アナヒラ6X6	SET SCREW, SOCKET (FT) M6X6	
30	S41759001	1	BMササエR	BM SUPPORT, R	
31	018501236	3	アナボルト5X12	BOLT, SOCKET M5X12	
32	S41760001	1	スライドイタ	SLIDE PLATE	
33	062401016	1	ナベコ4X10	SCREW, PAN M4X10	
34	028040246	1	バネザガネ2-4	WASHER, SPRING 2-4	
35	025040236	1	ヒラザガネチユウ4	WASHER, PLAIN M 4	
36	S41761001	1	BMタイチヨウセツジク	ADJUSTING SHAFT, BM BASE	
37	018061636	3	アナボルト6X16	BOLT, SOCKET M6X16	
38	S03695001	3	ザガネ6	WASHER, PLAIN 6	
39	104833009	1	ゴムセン4.3	RUBBER CAP, 4.3	
40	S41762009	1	モーターダイ750	MOTOR BASE, 750	
41	018062036	4	アナボルト6X20	BOLT, SOCKET M6X20	
42	028060246	4	バネザガネ2-6	WASHER, SPRING 2-6	
43	025060236	4	ヒラザガネチユウ6	WASHER, PLAIN M 6	
44	104450109	4	ゴムセン8	RUBBER CAP, 8	
48	S41765009	1	ウシロカバー	REAR COVER	
49	008400604	5	+トラスコ4X6	SCREW, TRUSS M4X6	
50	S41767000	1	ブローパイプ	BLOW PIPE	
51	S31704000	1	エアチューブ4X1260	AIR TUBE, 4X1260	
52	625010000	1	ナイロンクランフNK-2N	CORD HOLDER, NK-2N	
53	062400616	1	ナベコM4X6	SCREW, PAN M4X6	
54	S41768001	1	ベツトダイ	BEAD BASE	
55	S41769001	2	ヒンジジクササエ	HINGE SHAFT SUPPORT	
56	018403036	8	アナボルト4X30	BOLT, SOCKET M4X30	
57	104821009	2	ゴムセン10.5	RUBBER CAP, 10.5	
58	017086006	6	ボルト8X60	BOLT, M8X60	
59	213650001	6	ワ2.3X8.5X38ST	WASHER, 2.3X8.5X38ST	
60	028080246	6	バネザガネ2-8	WASHER, SPRING 2-8	
61	021080206	6	2シユナツト8	NUT, 2 M8	
62	158830001	2	ヒンジ	BED HINGE	
63	158831001	2	ヒンジピン	PIN	
64	048080342	2	トメワE8	RETAINING RING, E8	

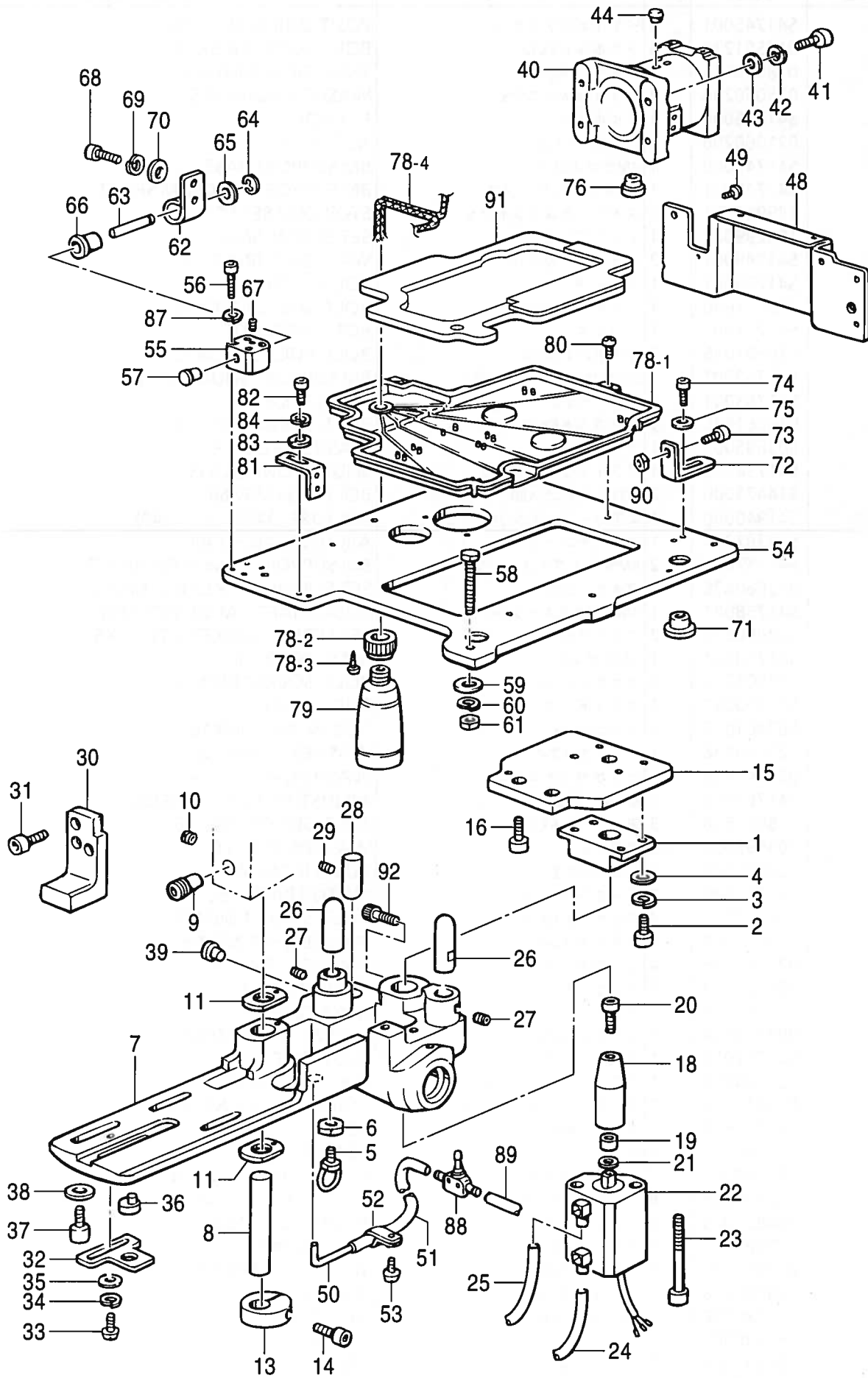

A2 . 主体関係 / Machine body / Maschinengehäuse / Corps de la machine / Cuerpo de la máquina

REF.NO.	CODE	Q'TY	ヒンメイ	NAME OF PARTS	RM
65	025100132	2	ヒラザガネシヨウ10	WASHER, PLAIN S 10	
66	158832009	2	ヒンジピンササエゴム	HINGE PIN SUPPORTER RUBBER	
67	012060636	2	アナヒラ6X6	SET SCREW, SOCKET (FT) M6X6	
68	018061636	4	アナボルト6X16	BOLT, SOCKET M6X16	
69	028060246	4	バネザガネ2-6	WASHER, SPRING 2-6	
70	025060236	4	ヒラザガネチユウ6	WASHER, PLAIN M 6	
71	S41770009	2	クツシヨン	CUSHION	
72	S41771001	1	ベッドコティダイ	BED SETTING BASE	
73	018061636	1	アナボルト6X16	BOLT, SOCKET M6X16	
74	018401236	2	アナボルト4X12	BOLT, SOCKET M4X12	
75	025040236	2	ヒラザガネチユウ4	WASHER, PLAIN M 4	
76	159928009	1	ゴムセン15	RUBBER CAP, 15	
78	S41772009	1	オイルハンクミ	OIL PAN ASSY	
78-1	S41773009	1	オイルハン	OIL PAN	
78-2	154467001	1	ハイユキヤツフ	DUST OILER	
78-3	037301215	2	Vナベタツピン3X12	TAPPING SCREW, PAN V M3X12	
78-4	S18093100	1	クミヒモ4X4	WICK, 4X4 (L = 1100)	
79	114486002	1	ホリオイラータイ	OILER	
80	062300616	5	ナベコM3X6	SCREW, PAN M3X6	
81	S41774001	1	センサーダイ	SENSOR BASE	
82	018400836	2	アナボルト4X8	BOLT, SOCKET M4X8	
83	025040236	2	ヒラザガネチユウ4	WASHER, PLAIN M 4	
84	028040246	2	バネザガネ2-4	WASHER, SPRING 2-4	
85	S41673001	1	アイガードクミ	EYE GUARD ASSY	
87	028040246	8	バネザガネ2-4	WASHER, SPRING 2-4	
88	S09197000	1	スピードコントローラ	SPEED CONTROLLER	
89	S14085001	1	エアチューブ	AIR TUBE, 4X82	
90	021060206	1	2シユナツト6	NUT, 2 M6	
91	S44775000	1	オイルハンフェルト	FELT	
92	018401236	1	アナボルト4X12	BOLT, SOCKET M4X12	

B. 上軸・針棒関係 / Upper shaft and needle bar mechanism

/ Obere Welle und Nadelstangenvorrichtung

/ Mécanisme de arbre supérieur et barra à aiguille

/ Mecanismo del eje superior y la barra de aguja

REF.NO.	CODE	Q'TY	ヒンメイ	NAME OF PARTS	RM
1	S41677001	1	ウワジク	UPPER SHAFT	
2	153040001	1	クランクロッドクミ	CRANK ROD ASSY	
2-1	144712001	2	シメネジ4.76	SCREW, SM4.76	
3	S41678001	1	ウワジクメタルF	UPPPER SHAFT BUSH, F	
4	014780622	1	アナトメネジ6.35クボミ	SET SCREW, SOCKET (CP) SM6.35	
5	140726000	1	ウワジクメタルM	UPPER SHAFT BUSH, M	
6	072630260	1	ベアリング6302VV	BALL BEARING, 6302VV	
7	048150142	1	トメワジクヨウC15	RETAINING RING, C15	
10	152231000	1	ツリアイクランク	COUNTER WEIGHT	
11	100250001	1	シメネジ7.14	SCREW, SM7.14	
12	014770622	2	アナトメネジ6.35クボミ	SET SCREW, SOCKET (CP) SM6.35	
13	101706001	1	トメネジ6.35	SET SCREW, SM6.35	
14	S41679001	1	ハリボウレンカンクミ	THREAD TAKE-UP LEVER ASSY	
14-1	S41680001	1	テンピンクミ	THREAD TAKE-UP ASSY	
14-2	152236001	1	テンピンササエジク	THREAD TAKE-UP SUPPORT STUD	
14-3	152237001	1	ハリボウクランク	NEEDLE BAR CRANK	
14-4	132051001	1	+サラネジ3.57L	SCREW, FLAT SM3.57L	
14-5	152238001	1	ハリボウレンカン	NEEDLE BAR CONNECTING ROD	
14-6	S41696001	1	ハリボウダキ8.72クミ	NEEDLE CLAMP ASSY, 8.72	
14-6-1	062680812	1	ナベコ437-40X8	SCREW, PAN SM4.37-40X8	
15	014760622	1	アナトメネジ5.95	SET SCREW, SOCKET SM5.95	
16	S41928001	3	ハリボウアンナイカクコマ	NEEDLE BAR GUIDE SLIDE BLOCK	
17	S37927000	2	ハリボウアンナイ	NEEDLE BAR GUIDE	
18	062670612	4	ナベコ357-40X6	SCREW, PAN SM3.57-40X6	
19	S41683000	1	ハリボウアンナイダイ	NEEDLE BAR GUIDE BASE	
20	062781412	2	ナベコ635-28X14	SCREW, PAN SM6.35-28X14	
21	S41684000	1	ハリボウアンナイF	NEEDLE BAR GUIDE, F	
22	018501036	2	アナボルト5X10	BOLT, SOCKET M5X10	
23	S41685001	1	ハリボウメタルU	NEEDLE BAR BUSH, U	
24	S41686001	1	ハリボウメタルD	NEEDLE BAR BUSH, D	
25	S41687001	1	ハリボウメタルダイF	NEEDLE BAR BUSH BASE, F	
26	154627001	1	ハリボウメタルDS	NEEDLE BAR BUSH, DS	
27	018681232	2	アナボルト437-40X12	BOLT, SOCKET SM4.37-40X12	
28	S37940001	1	イチギメピン	LOCATOR PIN	
29	S37928019	2	ミシンハリDPX17NY	NEEDLE, DPX17NY (#19)	
30	S41688000	1	スラストカラー	THRUST COLLAR	
31	014760622	2	アナトメネジ5.95	SET SCREW, SOCKET SM5.95	
32	101482001	1	レンカンシキリイタ	CONNECTING ROD PARTITION PLATE	
33	S41689001	1	ハリボウダキレンカン	NEEDLE BAR CLAMP LEVER	
34	S41697001	1	ハリボウダキ7.94クミ	NEEDLE BAR CLAMP ASSY, 7.92	
34-1	062680812	1	ナベコ437-40X8	SCREW, PAN SM4.37-40X8	
36	S41691001	1	ハリボウIP	NEEDEL BAR, IP	
37	S41692001	1	ホジヨハリボウ	AUXILIARY NEEDLE BAR	
38	S41693001	1	ダンネジ4	SHOULDER SCREW, M4	
39	S41694001	1	ハリドメアンナイ	NEEDLE CLAMP GUIDE	
40	S41695001	2	ハリドメ	NEEDLE CLAMP	
41	018680822	2	アナボルト4.37X8	BOLT, SOCKET SM4.37X8	
42	110735002	2	ザガネ	WASHER	
43	144458001	2	アタマツキトメネジ3.57	SET SCREW, SM3.57	
29	S37928021	2	" オプション部品 " ミシンハリDPX17NY	" OPTION PARTS " NEEDLE, DPX17NY (#21)	

C1 . 送り関係 / Feed mechanism / Transportvorrichtung / Mécanisme de l'entraînement / Mecanismo de la alimentación

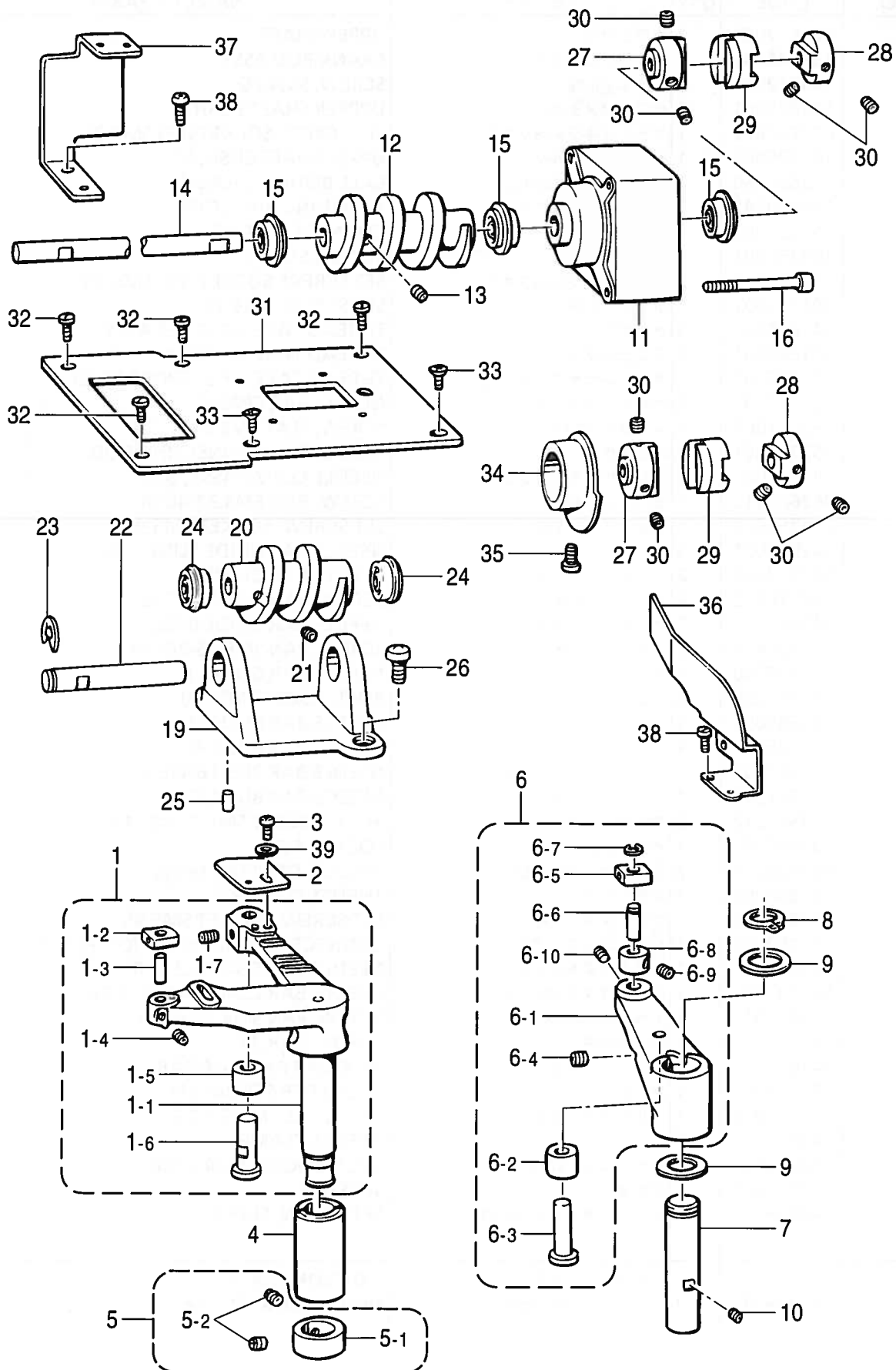

C1 . 送り関係 / Feed mechanism / Transportvorrichtung / Mécanisme de l'entraînement
/ Mecanismo de la alimentación

REF.NO.	CODE	Q'TY	ヒンメイ	NAME OF PARTS	RM
1	S41698001	1	Xオクリレバークミ	X-FEED LEVER ASSY	
1-1	S41699000	1	Xオクリレバ-100	X-FEED LEVER, 100	
1-2	152743001	1	ヨコオクリカクゴマ	TACK LENGTH SLIDE BLOCK	
1-3	156956001	1	リンクジク	LINK SHAFT	
1-4	014760622	1	アナトメネジ5.95	SET SCREW, SOCKET SM5.95	
1-5	S37932001	1	オクリカムコロ	FEED CAM ROLLER	
1-6	S37933001	1	コロジク	ROLLER SHAFT	
1-7	014760622	1	アナトメネジ5.95	SET SCREW, SOCKET SM5.95	
2	S41700001	1	ゲンテンドグX	HOME POSITION DOG, X	
3	062680612	1	ナベコ4.37-40X6	SCREW, PAN SM4.37-40X6	
4	S37934001	1	Xオクリレバ-メタル	FEED LEVER BUSH, X	
5	183493001	1	オクリジクセツトカラークミ	SET SCREW COLLAR ASSY	
5-1	S09212001	1	セツトカラー	SET SCREW COLLAR	
5-2	101706001	2	トメネジ6.35	SET SCREW, SM6.35	
6	S41701001	1	Yオクリレバークミ	Y-FEED LEVER ASSY	
6-1	S37936001	1	Yオクリレバ-	Y-FEED LEVER	
6-2	152743001	1	ヨコオクリカクゴマ	TACK LENGTH SLIDE BLOCK	
6-3	S37933001	1	コロジク	ROLLER SHAFT	
6-4	014760622	1	アナトメネジ5.95	SET SCREW, SOCKET SM5.95	
6-5	152743001	1	ヨコオクリカクゴマ	TACK LENGTH SLIDE BLOCK	
6-6	S41702001	1	カクコマジク	SLIDE BLOCK SHAFT	
6-7	048040342	1	トメワE4	RETAINING RING, E4	
6-8	S28090001	1	セツトカラー	SET SCREW COLLAR	
6-9	014680422	1	アナトメネジ4.37クボミ	SET SCREW, SOCKET (CP) SM4.37	
6-10	014760622	1	アナトメネジ5.95	SET SCREW, SOCKET SM5.95	
7	152760051	1	タテオクリレバ-ジク	VERTICAL FEEDING LEVER SHAFT	
8	048180142	1	トメワジクヨウC18	RETAINING RING, C18	
9	152756001	2	スラストザガネ18	THRUST WASHER, 18	
10	014760622	1	アナトメネジ5.95	SET SCREW, SOCKET SM5.95	
11	S41703000	1	PMブラケットX	PM BRACKET, X	
12	S41704001	1	オクリカムX	FEED CAM	
13	014760622	2	アナトメネジ5.95	SET SCREW, SOCKET SM5.95	
14	S41705001	1	カムジクX	CAM SHAFT, X	
15	070688850	3	タマジクウケ688ZZNR	BALL BEARING, 688ZZNR	
16	018404532	4	アナボルト4X45	BOLT, SOCKET M4X45	
19	S37937001	1	オクリカムブラケット	FEED CAM BRACKET	
20	S37941001	1	オクリカムY	FEED CAM, Y	
21	014760622	2	アナトメネジ5.95	SET SCREW, SOCKET SM5.95	
22	S37939001	1	カムジク	CAM SHAFT	
23	048060342	1	トメワE6	RETAINING RING, E6	
24	070688850	2	タマジクウケ688ZZNR	BALL BEARING, 688ZZNR	
25	S37940001	2	イチギメピン	LOCATOR PIN	
26	062681012	2	ナベコ437-40X10	SCREW, PAN SM4.37-40X10	
27	S37942000	2	カツプリングハブ8	COUPLING HUB, 8	
28	S37943000	2	カツプリングハブ6.35	COUPLING HUB, 6.35	
29	S37944000	2	カツプリングスヘーサ	COUPLING SPACER	
30	014760622	8	アナトメネジ5.95	SET SCREW, SOCKET SM5.95	
31	S41706001	1	オクリダイアンナイイタ	FEED BAR GUIDE PLATE	
32	145318001	4	シメネジ4.37	SCREW, SM4.37	
33	100032004	2	サラネジ4.37	SCREW, FLAT SM4.37	
34	S37946001	1	オクリゲンテンドグ	FEED HOME POSITION DOG	
35	062300512	1	ナベコ3X5	SCREW, PAN M3X5	
36	S37947001	1	ゲンテンセンサートリツケイタ	HOME POSITION SENSOR SET PLATE	
37	S41707001	1	Xセンサートリツケイタ	X-SENSOR SETTING PLATE	
38	062680612	2	ナベコ4.37-40X6	SCREW, PAN SM4.37-40X6	
39	100645003	1	ザガネ	WASHER	

C2 . 送り関係 / Feed mechanism / Transportvorrichtung / Mécanisme de l'entraînement / Mecanismo de la alimentación

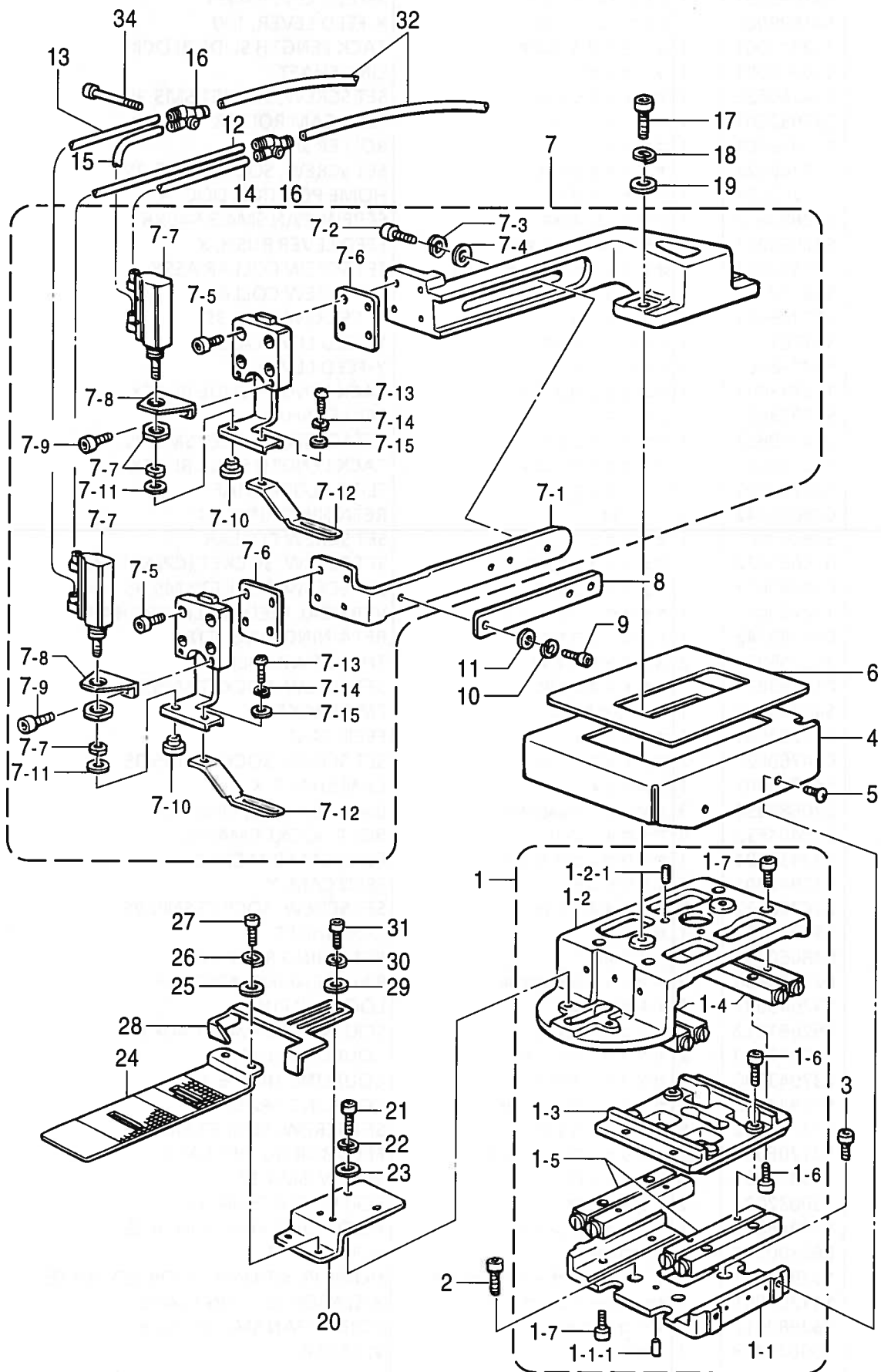

C2. 送り関係 / Feed mechanism / Transportvorrichtung / Mécanisme de l'entraînement
/ Mecanismo de la alimentación

REF.NO.	CODE	Q'TY	ヒンメイ	NAME OF PARTS	RM
1	S41777001	1	オクリダイクミ	FEED BAR ASSY	
1-1	S41778001	1	オクリドダイクミ	FEED BASE ASSY	
1-1-1	S16431001	2	5X11ジク	STUD, 5X11	
1-2	S41780001	1	オクリダイXクミ	FEED BAR ASSY, X	
1-2-1	S16431001	2	5X11ジク	STUD, 5X11	
1-3	S41782001	1	オクリダイY	FEED BAR, Y	
1-4	S41783000	1	クロスローラX	CROSS ROLLER, X	
1-5	S41784000	1	クロスローラY	CROSS ROLLER, Y	
1-6	018501636	8	アナボルト5X16	BOLT, SOCKET M5X16	
1-7	018501036	8	アナボルト5X10	BOLT, SOCKET M5X10	
2	018500836	3	アナボルト5X8	BOLT, SOCKET M5X8	
3	018500636	1	アナボルト5X6	BOLT, SOCKET M5X6	
4	S41785001	1	オクリカバー	FEED COVER	
5	008400604	2	+トラスコ4X6	SCREW, TRUSS M4X6	
6	S41786000	1	オクリカザリイタ	FEED DECORATIVE PLATE	
7	S41787101	1	オサエウデクミA	WORK CLAMP ARM ASSY, A	
7-1	S41789001	1	オサエゼンゴウデ	WOCK CLAMP SET ARM	
7-2	018401636	2	アナボルト4X16	BOLT, SOCKET M4X16	
7-3	028040246	2	バネザガネ2-4	WASHER, SPRING 2-4	
7-4	025040236	2	ヒラザガネチユウ4	WASHER, PLAIN M 4	
7-5	018401036	8	アナボルト4X10	BOLT, SOCKET M4X10	
7-6	S41791000	2	スパーサ	SPACER	
7-7	S41792000	2	シリンダクミ	CYLINDER ASSY	
7-8	S41794001	2	フートA	FOOT, A	
7-9	018400836	4	アナボルト4X8	BOLT, SOCKET M4X8	
7-10	S14974001	2	オサエナツト	PRESSER NUT	
7-11	102707002	2	ザガネ	WASHER, PLAIN 4	
7-12	※	2	オサエ	WORK CLAMP	
7-13	S21716001	2	ボタンヘッドネジ4X10	SCREW, BUTTON HEAD M4X10	
7-14	028040246	2	バネザガネ2-4	WASHER, SPRING 2-4	
7-15	102707002	2	ザガネ	WASHER, PLAIN 4	
8	S41801001	1	オクリホキヨウイタ	FEED PROTECTED PLATE	
9	018401036	2	アナボルト4X10	BOLT, SOCKET M4X10	
10	028040246	2	バネザガネ2-4	WASHER, SPRING 2-4	
11	025040236	2	ヒラザガネチユウ4	WASHER, PLAIN M 4	
12	S18387007	1	エアーチューブ	AIR TUBE, 4 (L = 370)	
13	S08125000	1	エアーホース4-S1	AIR TUBE, 4-S1 (L = 410)	
14	S41635000	1	エアホース0425S031B	AIR TUBE, 0425S (L = 310)	
15	S41935000	1	エアホース0425S035B	AIR TUBE, 0425S (L = 350)	
16	S19557000	2	コガタユニオンワイ4	MINIATURE UNION, Y4	
17	018501636	2	アナボルト5X16	BOLT, SOCKET M5X16	
18	028050246	2	バネザガネ2-5	WASHER, SPRING 2-5	
19	025050236	2	ヒラザガネチユウ5	WASHER, PLAIN M 5	
20	S41802001	1	オクリイタダイ	FEED PLATE BASE	
21	018401036	2	アナボルト4X10	BOLT, SOCKET M4X10	
22	028040242	2	バネザガネ2-4	WASHER, SPRING 2-4	
23	025040136	2	ヒラザガネシヨウ4	WASHER, PLAIN S 4	
24	※	1	オクリイタ	FEED PLATE	
25	S19543001	2	ザガネ	WASHER	
26	028040246	2	バネザガネ2-4	WASHER, SPRING 2-4	
27	018400636	2	アナボルト4X6	BOLT, SOCKET M4X6	
28	S41804001	1	ミゴロジウギ	RULLER	
29	025040236	2	ヒラザガネチユウ4	WASHER, PLAIN M 4	
30	028040246	2	バネザガネ2-4	WASHER, SPRING 2-4	
31	018400836	2	アナボルト4X8	BOLT, SOCKET M4X8	
32	S41943000	2	エアホース0425S145B	AIR TUBE, 0425S (L = 1450)	
34	S46740001	1	+ナベコ3X42	SCREW, PAN M3X42	

D1 . フィーダー関係 / Feeder mechanism / Knopfsortierer / Tricur de boutons
 / Mecanismo de botones

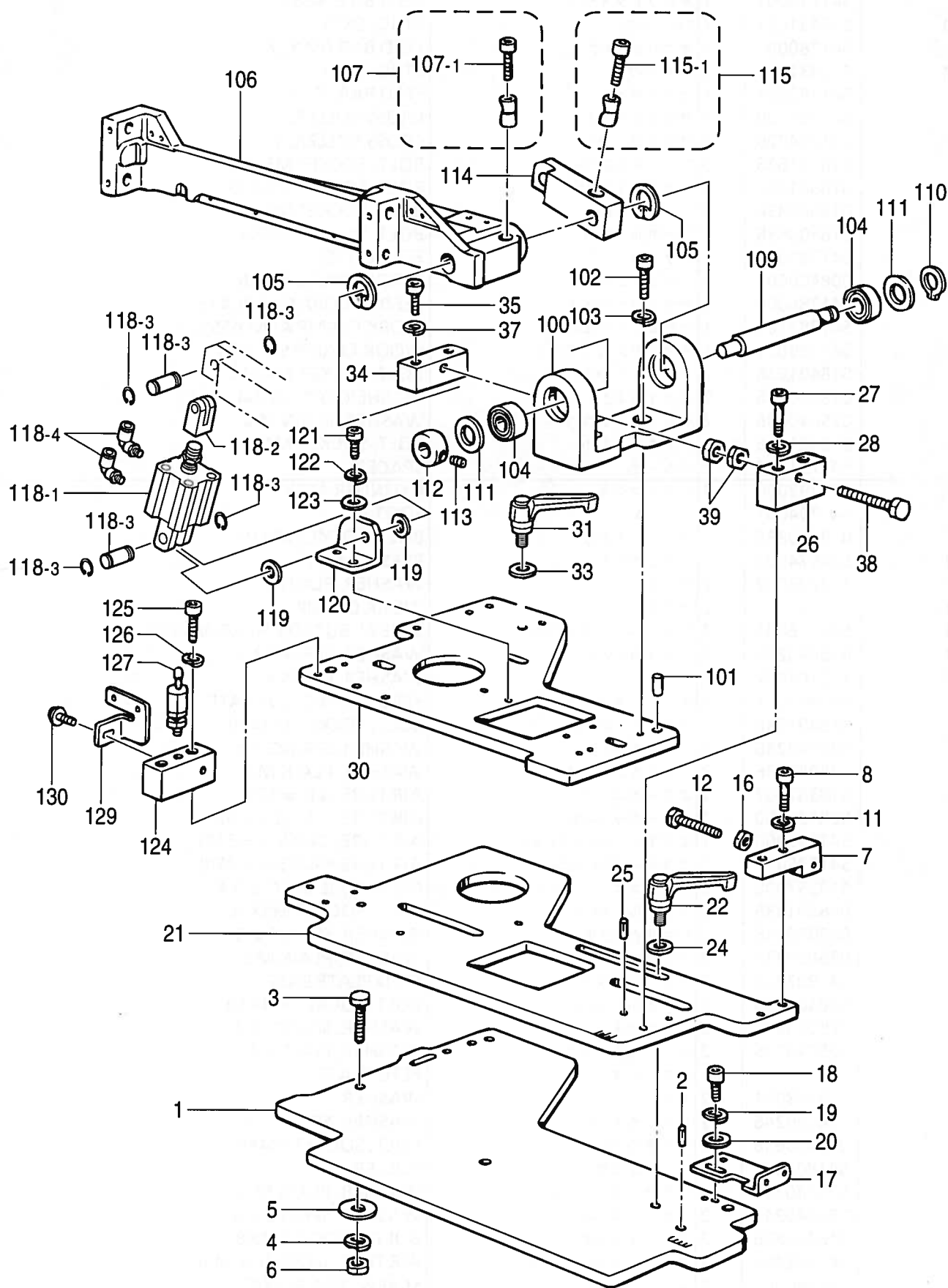

D1. フィーダー関係 / Feeder mechanism / Knopfsortierer / Tricur de boutons
/ Mecanismo de botones

REF.NO.	CODE	Q'TY	ヒンメイ	NAME OF PARTS	RM
1	S41511001	1	フィーダーベースイタ	FEEDER BASE PLATE	
2	118550001	2	ミゾツキピン	PIN, DOWEL	
3	017086006	3	ボルト8X60	BOLT, M8X60	
4	028080246	3	バネザガネ2-8	WASHER, SPRING 2-8	
5	213650001	3	ワ2.3X8.5X38ST	WASHER, 2.3X8.5X38ST	
6	021080206	3	2シユナツト8	NUT, 2 M8	
7	S41512001	1	イチギメブロックC	POSITIONING BLOCK, C	
8	018062036	2	アナボルト6X20	BOLT, SOCKET M6X20	
11	028060246	2	バネザガネ2-6	WASHER, SPRING 2-6	
12	S24089001	1	ボルト8X50	BOLT, M8X50	
16	021080206	1	2シユナツト8	NUT, 2 M8	
17	S41960001	1	センサートリツケイタ	SENSOR SETTING PLATE	
18	018401036	2	アナボルト4X10	BOLT, SOCKET M4X10	
19	028040246	2	バネザガネ2-4	WASHER, SPRING 2-4	
20	025040236	2	ヒラザガネチユウ4	WASHER, PLAIN M 4	
21	S41513001	1	フィーダータイヒイタ	FEEDER TAKE SHELTER PLATE	
22	S44688000	1	クランプレバー	CLAMPING LEVER	
24	S43640001	1	ザガネ	WASHER	
25	118550001	2	ミゾツキピン	PIN, DOWEL	
26	S41514001	1	イチギメブロックB	POSITIONING BLOCK, B	
27	018063036	2	アナボルト6X30	BOLT, SOCKET M6X30	
28	028060246	2	バネザガネ2-6	WASHER, SPRING 2-6	
30	S41515001	1	ハバチヨウセイイタ	LOOP WIDTH ADJUSTING PLATE	
31	S44688000	1	クランプレバー	CLAMPING LEVER	
33	S43640001	1	ザガネ	WASHER	
34	S41516001	1	イチギメブロックA	POSITIONING BLOCK, A	
35	018063036	2	アナボルト6X30	BOLT, SOCKET M6X30	
37	028060246	2	バネザガネ2-6	WASHER, SPRING 2-6	
38	S24250001	1	ボルト8X90	BOLT, M8X90	
39	021080206	2	2シユナツト8	NUT, 2 M8	
100	S41517000	1	シリンダーウデブラケット	CYLINDER ARM BRACKET	
101	156958001	2	スイハイオクリウデジク	FEED ROCK ARM STUD	
102	018062036	2	アナボルト6X20	BOLT, SOCKET M6X20	
103	028060246	2	バネザガネ2-6	WASHER, SPRING 2-6	
104	076002800	2	タマジクウケ6002ZZ	BALL BEARING, 6002ZZ	
105	048320242	2	トメワアナヨウC32	RETAINING RING, C32	
106	S41518101	1	クドウシリンダーウデ	DRIVING CYLINDER ARM	
107	S09132051	1	ピンチスリーブクミ	PINCH SLEEVE ASSY	
107-1	018063022	1	アナボルト6X30	BOLT, SOCKET M6X30	
109	S41519001	1	シリンダトリツケウデジク	CYLINDER SETTING ARM SHAFT	
110	048150142	1	トメワジクヨウC15	RETAINING RING, C15	
111	116920001	2	オクリジクスラストリング	THRUST RING	
112	S12134001	1	ナカオサエカラー	INNER PRESSER COLLAR	
113	012060636	2	アナヒラ6X6	SET SCREW, SOCKET (FT) M6X6	
114	S41520001	1	シリンダレンカン	CYLINDER CONNECTING ROD	
115	S09132051	1	ピンチスリーブクミ	PINCH SLEEVE ASSY	
115-1	018063022	1	アナボルト6X30	BOLT, SOCKET M6X30	
118	S41521000	1	シリンダー25X10クミ	CYLINDER ASSY, 25X10	
118-1	S41522000	1	シリンダー25X10	CYLINDER, 25X10	
118-2	S41523000	1	2ヤマナツクルジョイント	KNUKLE JOINT	
118-3	S41524000	2	ナツクルヨウピン	PIN	
118-4	S11426000	2	エルボユニオン4M5	ELBOW UNION, 4M5	
119	025100236	2	ヒラザガネチユウ10	WASHER, PLAIN M 10	
120	S41525001	1	シリンダササエ	CYLINDER SUPPORT	
121	018061636	2	アナボルト6X16	BOLT, SOCKET M6X16	
122	028060246	2	バネザガネ2-6	WASHER, SPRING 2-6	
123	025060236	2	ヒラザガネチユウ6	WASHER, PLAIN M 6	
124	S41526001	1	ストツハーダイ	STOPPER BASE	
125	018061636	2	アナボルト6X16	BOLT, SOCKET M6X16	
126	028060246	2	バネザガネ2-6	WASHER, SPRING 2-6	
127	S14874000	1	シヨツクアブソーバ	SHOCK ABSORBER	
129	S41527001	1	センサートリツケイタ	SENSOR SETTING PLATE	
130	0A5401006	1	ナベコバネヒラ4X10	SCREW, PAN (S/P WASHER) M4X10	

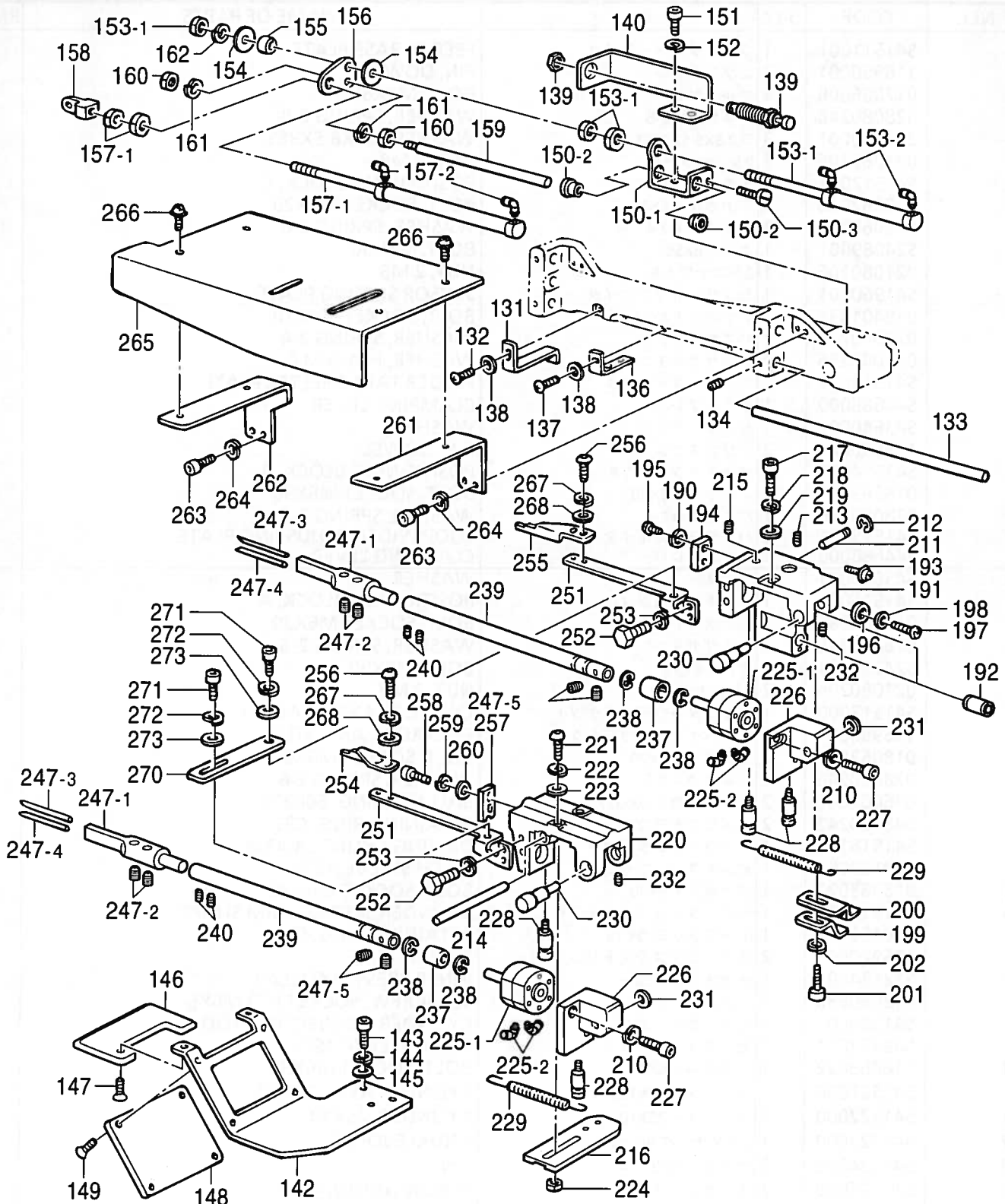

オプション部品 / OPTION PARTS

薄物ループ用 / For light materials loop

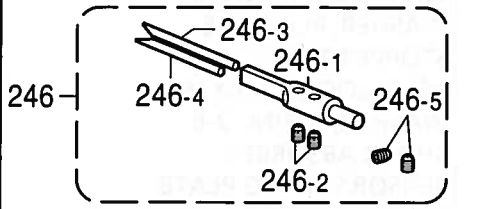

厚物ループ用 / For heavy materials loop

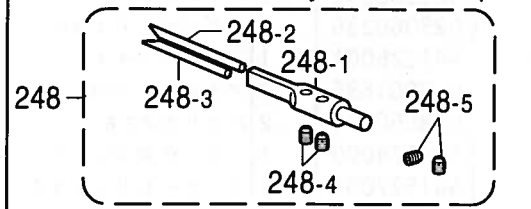

D2. フィーダー関係 / Feeder mechanism / Knopfsortierer / Tricur de boutons
/ Mecanismo de botones

REF.NO.	CODE	Q'TY	ヒンメイ	NAME OF PARTS	RM
131	S41528001	1	センサードグ	SENSOR DOG	
132	060400816	1	バインド4X8	SCREW, BIND M4X8	
133	S41529001	2	ホークユニットアンナイジク	FORK UNIT GUIDE SHAFT	
134	012500536	4	アナヒラ5X5	SET SCREW, SOCKET (FT) M5X5	
136	S41530001	4	センサートリツケイタ	SENSOR SETTING PLATE	
137	060400816	4	バインド4X8	SCREW, BIND M4X8	
138	025040236	5	ヒラザガネチユウ4	WASHER, PLAIN M 4	
139	S44979000	1	シヨツクアブソバ	SHOCK ABSORBER	
140	S44978001	1	アブソバダイ	ABSORBER BRACKET	
142	S41912001	1	ハンドガードササエ	HAND GUARD SUPPORT	
143	018061436	2	アナホルト6X14	BOLT, SOCKET M6X14	
144	028060246	2	バネザガネ2-6	WASHER, SPRING 2-6	
145	025060236	2	ヒラザガネチユウ6	WASHER, PLAIN M 6	
146	S41913100	1	ハンドガード1	HAND GUARD, 1	
147	004400814	2	+サラコ4X8	SCREW, FLAT M4X8	
148	S41914000	1	ハンドガード2	HAND GUARD, 2	
149	S31258001	4	+サラコ4X6	SCREW, FLAT M4X6	
150	S41531001	1	シリンダードダイクミ	CYLINDER BASE ASSY	
150-1	S41532001	1	シリンダードダイ	CYLINDER BASE	
150-2	S41533000	2	フランジブツシユ	FLANGE BUSHING	
150-3	060400616	2	バインドM4X6	SCREW, BIND M4X6	
151	018062036	2	アナホルト6X20	BOLT, SOCKET M6X20	
152	028060246	2	バネザガネ2-6	WASHER, SPRING 2-6	
153	S41534000	1	シリンダ16X40クミ	CYLINDER ASSY, 16X40	
153-1	S41535000	1	シリンダ16X40	CYLINDER, 16X40	
153-2	S11426000	2	エルボユニオン4M5	ELBOW UNION, 4M5	
154	116662004	2	ザガネ	WASHER, PLAIN	
155	153218001	1	シタイトサバキカラー	LOWER THREAD RETAINER COLLAR	
156	S41536001	1	シリンダレンケツイタ	CYLINDER CONNECTING PLATE	
157	S41537000	1	シリンダ16X125クミ	CYLINDER ASSY, 16X125	
157-1	S41538000	1	シリンダ16X125	CYLINDER, 16X125	
157-2	S11426000	2	エルボユニオン4M5	ELBOW UNION, 4M5	
158	S37454000	1	1ヤマナツクルジョイント	KNUCLE JOINT	
159	S41539001	1	ガイドジク	GUIDE SHAFT	
160	021500216	2	2シユナツト5	NUT, 2 M5	
161	028050246	2	バネザガネ2-5	WASHER, SPRING 2-5	
162	028050246	1	バネザガネ2-5	WASHER, SPRING 2-5	
190	028030246	2	バネザガネ2-3	WASHER, SPRING 2-3	
191	S41540000	1	ホークブラケツトR	FORK BRACKET, R	
192	S12004000	4	リニアブツシユ	LINEAR BUSH	
193	0A5400806	2	+ナベザクミ4X8DB	SCREW, PAN (S/P WASHER) M4X8	
194	S23653001	1	スライドダイストツバ	SLIDE BASE STOPPER	
195	062300502	2	ナベコ3X5	SCREW, PAN M3X5	
196	S12054000	1	クツシヨソ	CUSHION	
197	062401016	1	ナベコ4X10	SCREW, PAN M4X10	
198	025040236	1	ヒラザガネチユウ4	WASHER, PLAIN M 4	
199	S41541001	1	ホークイチケンシユツドグ	FORK POSITION DETECTOR DOG	
200	S41630001	1	ホークイチケンシユツドグ2	FORK POSITION DETECTOR DOG, 2	
201	018401036	2	アナホルト4X10	BOLT, SOCKET M4X10	
202	028040246	2	バネザガネ2-4	WASHER, SPRING 2-4	
210	028040246	2	バネザガネ2-4	WASHER, SPRING 2-4	
211	S41542001	1	ピン	PIN	
212	048050142	1	トメワジクヨウC5	RETAINING RING, C5	
213	012400436	2	アナヒラ4X4	SET SCREW, SOCKET (FT) M4X4	
214	S41544001	1	アンナイジク	GUIDE SHAFT	
215	012060636	1	アナヒラ6X6	SET SCREW, SOCKET (FT) M6X6	
216	S41545201	1	ホークスライドイタ	FORK SLIDE PLATE	
217	018501236	2	アナホルト5X12	BOLT, SOCKET M5X12	
218	028050246	2	バネザガネ2-5	WASHER, SPRING 2-5	

D2 . フィーダー関係 / Feeder mechanism / Knopfsortierer / Tricur de boutons
/ Mecanismo de botones

REF.NO.	CODE	Q'TY	ヒンメイ	NAME OF PARTS	RM
219	026050136	2	ヒラザガネコガタ5	WASHER, PLAIN S 5	
220	S41543100	1	ホークブラケットF	FORK BRACKET, F	
221	S43636001	2	ボタンヘッドネジ5X18	SCREW, BUTTON HEAD M5X18	
222	028050246	2	バネザガネ2-5	WASHER, SPRING 2-5	
223	026050136	2	ヒラザガネコガタ5	WASHER, PLAIN S 5	
224	021500216	2	2シユナツト5	NUT, 2 M5	
225	S41548100	2	ロータリーシリンダ20クミ	ROTARY CYLINDER ASSY, 20	
225-1	S41549100	2	ロータリーシリンダ	ROTARY CYLINDER	
225-2	S11426000	4	エルボユニオン4M5	ELBOW UNION, 4M5	
226	S41550100	2	シリンダートリツケタイ	CYLINDER SETTING BASE	
227	018402536	4	アナボルト4X25	BOLT, SOCKET M4X25	
228	S13330001	4	バネカケ	SPRING HOOK	
229	S16422001	2	ヒキバネ	SPRING	
230	S41551001	2	ロータリーシリンダージク	ROTARY CYLINDER SHAFT	
231	110367001	2	ザガネ	WASHER, PLAIN SPECIAL 8	
232	012500536	2	アナヒラ5X5	SET SCREW, SOCKET (FT) M5X5	
237	S41553000	2	ホークブツシュ	FORK BUSHING	
238	048120142	4	トメワジクヨウC12	RETAINING RING, C12	
239	S43958001	2	ホークカナグジク	FORK SHAFT	
240	012400436	4	アナヒラ4X4	SET SCREW, SOCKET (FT) M4X4	

247	S44958001	2	<中厚物ループ用> ホークカナグBクミ	<For medium materials loop> FORK ASSY, B	
247-1	S43960001	2	ホークカナグB	FORK, B	
247-2	012400436	4	アナヒラ4X4	SET SCREW, SOCKET (FT) M4X4	
247-3	S41626001	2	ホークジク2.0L	FORK SHAFT, 2.0L	
247-4	S41627001	2	ホークジク2.0S	FORK SHAFT, 2.0S	
247-5	012400436	4	アナヒラ4X4	SET SCREW, SOCKET (FT) M4X4	

251	S41556101	2	ユルメオサエトリツケイタ	LOOSEN LOOP PRESSER SET PLATE	
252	017501006	4	ボルト5X10	BOLT, M5X10	
253	028050246	4	バネザガネ2-5	WASHER, SPRING 2-5	
254	S41557001	1	ユルメオサエF	LOOSEN LOOP PRESSER FOOT, F	
255	S41558001	1	ユルメオサエB	LOOSEN LOOP PRESSER FOOT, B	
256	S21715001	4	ボタンヘッドネジ4X6	SCREW, BUTTON HEAD M4X6	
257	S41559000	1	ホークカナグストツハ	FORK STOPPER	
258	018401636	2	アナボルト4X16	BOLT, SOCKET M4X16	
259	028040246	2	バネザガネ2-4	WASHER, SPRING 2-4	
260	025040236	2	ヒラザガネチユウ4	WASHER, PLAIN M 4	
261	S41560001	1	カバートリツケイタA	COVER SETTING PLATE, A	
262	S41561001	1	カバートリツケイタB	COVER SETTING PLATE, B	
263	018401036	4	アナボルト4X10	BOLT, SOCKET M4X10	
264	028040246	4	バネザガネ2-4	WASHER, SPRING 2-4	
265	S41563109	1	フィダーカバー	FEEDER COVER	
266	0A5400806	4	+ナベザクミ4X8DB	SCREW, PAN (S/P WASHER) M4X8	
267	028040246	4	バネザガネ2-4	WASHER, SPRING 2-4	
268	025040236	4	ヒラザガネチユウ4	WASHER, PLAIN M 4	
270	S43634101	1	レンケツイタ	CONNECTING PLATE	
271	018400836	2	アナボルト4X8	BOLT, SOCKET M4X8	
272	028040246	2	バネザガネ2-4	WASHER, SPRING 2-4	
273	025040236	2	ヒラザガネチユウ4	WASHER, PLAIN M 4	

D2.フィーダー関係 / Feeder mechanism / Knopfsortierer / Tricur de boutons
/ Mecanismo de botones

REF.NO.	CODE	Q'TY	ヒンメイ	NAME OF PARTS	RM
" オプション部品 "					
<薄物ループ用>					
246	S44957001	2	ホークカナグAクミ	FORK ASSY, A	
246-1	S43959001	2	ホークカナグA	FORK, A	
246-2	012400436	4	アナヒラ4X4	SET SCREW, SOCKET (FT) M4X4	
246-3	S41626001	2	ホークジク2.0L	FORK SHAFT, 2.0L	
246-4	S41627001	2	ホークジク2.0S	FORK SHAFT, 2.0S	
246-5	012400436	4	アナヒラ4X4	SET SCREW, SOCKET (FT) M4X4	

<厚物ループ用>					
248	S44959001	2	ホークカナグCクミ	FORK ASSY, C	
248-1	S43961001	2	ホークカナグC	FORK, C	
248-2	012400436	4	アナヒラ4X4	SET SCREW, SOCKET (FT) M4X4	
248-3	S41626001	2	ホークジク2.0L	FORK SHAFT, 2.0L	
248-4	S14627001	2	ホークジク2.0S	FORK SHAFT, 2.0S	
248-5	012400436	4	アナヒラ4X4	SET SCREW, SOCKET (FT) M4X4	

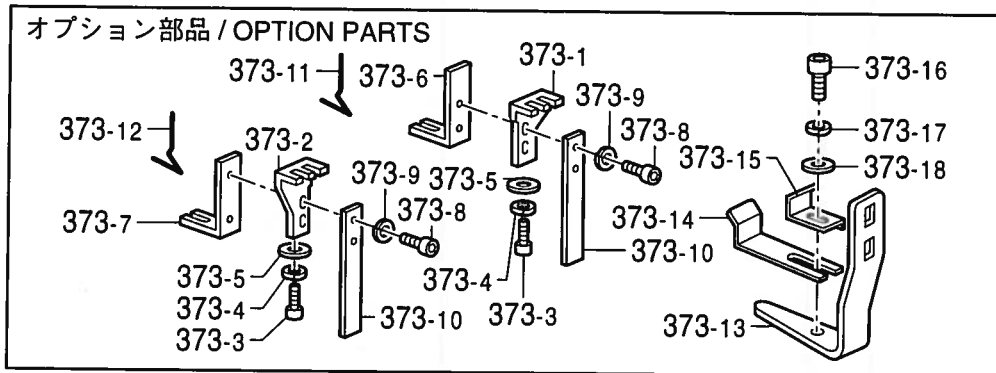
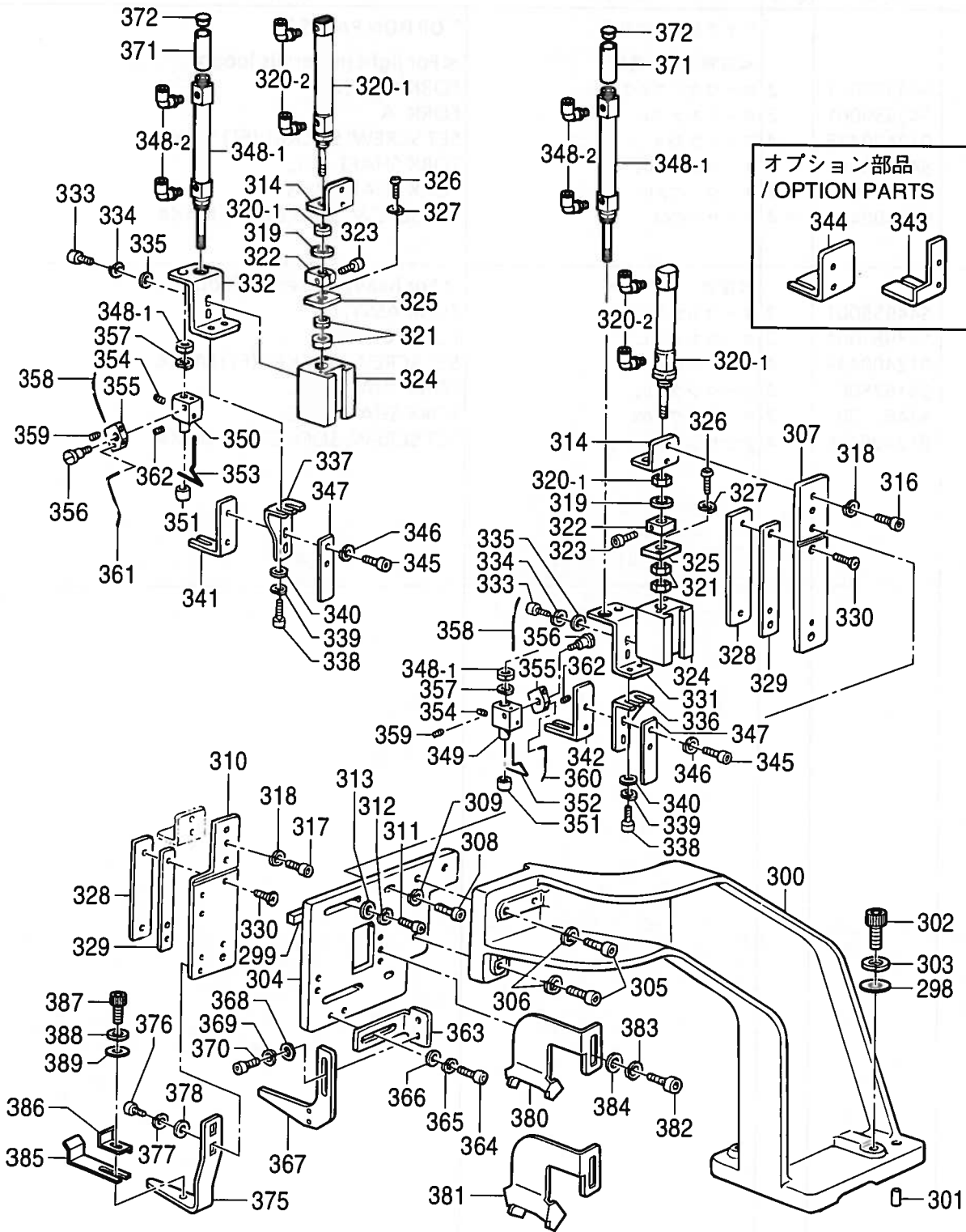

D3.フィーダー関係 / Feeder mechanism / Knopfsortierer / Tricur de boutons
/ Mecanismo de botones

REF.NO.	CODE	Q'TY	ヒンメイ	NAME OF PARTS	RM
298	025060236	2	ヒラザガネチユウ6	WASHER, PLAIN M 6	
299	S44980001	1	キー3X3X77	KEY, 3X3X77	
300	S41562009	1	ループユニットダイ	LOOP UNIT BASE	
301	156958001	2	スイヘイオクリウデシク	FEED ROCK ARM STUD	
302	018062536	3	アナボルト6X25	BOLT, SOCKET M6X25	
303	028060246	3	バネザガネ2-6	WASHER, SPRING 2-6	
304	S41564201	1	オリユニットトリツケイタ	PRESSER UNIT SETTING PLATE	
305	018502036	3	アナボルト5X20	BOLT, SOCKET M5X20	
306	028050246	3	バネザガネ2-5	WASHER, SPRING 2-5	
307	S41565101	1	スライダーベースB	SLIDER BASE, B	
308	018401036	2	アナボルト4X10	BOLT, SOCKET M4X10	
309	028040246	2	バネザガネ2-4	WASHER, SPRING 2-4	
310	S41566101	1	スライダーベースF	SLIDER BASE, F	
311	018401036	2	アナボルト4X10	BOLT, SOCKET M4X10	
312	028040246	2	バネザガネ2-4	WASHER, SPRING 2-4	
313	158722002	4	ザガネ4.2	WASHER, PLAIN 4.2	
314	S41567001	2	シリンダートリツケイタA	CYLINDER SETTING PLATE, A	
316	018400836	2	アナボルト4X8	BOLT, SOCKET M4X8	
317	018400836	2	アナボルト4X8	BOLT, SOCKET M4X8	
318	028040246	4	バネザガネ2-4	WASHER, SPRING 2-4	
319	S44976000	2	クツシヨンゴム	CUSHION RUBBER	
320	S41568000	2	シリンダー10X45クミ	CYLINDER ASSY, 10X45	
320-1	S41569000	2	シリンダー10X45	CYLINDER, 10X45	
320-2	S11426000	2	エルボユニオン4M5	ELBOW UNION, 4M5	
321	021400316	4	3シユナツト4	NUT, 3 M4	
322	S41570001	2	シリンダーストツハ	CYLINDER STOPPER	
323	018400836	2	アナボルト4X8	BOLT, SOCKET M4X8	
324	S41571001	2	スライダブラケット	SLIDER BRACKET	
325	S41572001	2	ロツドオサエイタ	ROD PRESSER PLATE	
326	060400816	4	バインド4X8	SCREW, BIND M4X8	
327	028040246	4	バネザガネ2-4	WASHER, SPRING 2-4	
328	S41573001	2	スライダガイド	SLIDER GUIDE	
329	S41574001	2	スライダガイドスヘーサ	SLIDER GUIDE SPACER	
330	004400814	4	+サラコ4X8	SCREW, FLAT M4X8	
331	S44972001	1	シリンダートリツケイタBB	CYLINDER SETTING PLATE, BB	
332	S44973001	1	シリンダートリツケイタBF	CYLINDER SETTING PLATE, BF	
333	018401036	4	アナボルト4X10	BOLT, SOCKET M4X10	
334	028040246	4	バネザガネ2-4	WASHER, SPRING 2-4	
335	025040236	4	ヒラザガネチユウ4	WASHER, PLAIN M 4	
336	S41577001	1	ループオサエトリツケイタB	LOOP PRESSER SETTING PLATE, B	
337	S41578001	1	ループオサエトリツケイタF	LOOP PRESSER SETTING PLATE, F	
338	018400836	4	アナボルト4X8	BOLT, SOCKET M4X8	
339	028040246	4	バネザガネ2-4	WASHER, SPRING 2-4	
340	025040236	4	ヒラザガネチユウ4	WASHER, PLAIN M 4	
341	S41579001	1	ループオサエB	LOOP PRESSER, B	
342	S41580001	1	ループオサエF	LOOP PRESSER, F	
345	018400836	4	アナボルト4X8	BOLT, SOCKET M4X8	
346	028040246	4	バネザガネ2-4	WASHER, SPRING 2-4	
347	S41911101	2	ループワイパー	LOOP WIPER	
348	S44209000	2	シリンダー10X30クミ	CYLINDER ASSY, 10X30	
348-1	S44210000	2	シリンダー10X30	CYLINDER, 10X30	
348-2	S11426000	2	エルボユニオン4M5	ELBOW UNION, 4M5	
349	S41583001	1	オサエブロックB	PRESSER BLOCK, B	
350	S41584001	1	オサエブロックF	PRESSER BLOCK, F	
351	S05356000	2	ボタンオサエA	BUTTON PRESSER, A	
352	S41585101	1	ループオサエUB	LOOP PRESSER, UB	
353	S41586101	1	ループオサエUF	LOOP PRESSER, UF	
354	012400436	2	アナヒラ4X4	SET SCREW, SOCKET (FT) M4X4	
355	S41587001	2	ハバヨセブロック	WIDTH NARROW BLOCK	

D3. フィーダー関係 / Feeder mechanism / Knopfsortierer / Tricur de boutons
/ Mecanismo de botones

REF.NO.	CODE	Q'TY	ヒンメイ	NAME OF PARTS	RM
356	155103001	2	ダンネジ3.18	SHOULDER SCREW, SM3.18	
357	028040246	2	バネザガネ2-4	WASHER, SPRING 2-4	
358	S41588001	2	アンナイバネ	GUIDE SPRING	
359	012400436	2	アナヒラ4X4	SET SCREW, SOCKET (FT) M4X4	
360	S41589001	1	ハバヨセバネB	SPRING, WIDTH NARROW (B)	
361	S41590001	1	ハバヨセバネF	SPRING, WIDTH NARROW (F)	
362	012400436	2	アナヒラ4X4	SET SCREW, SOCKET (FT) M4X4	
363	S41591001	1	ルーフウカシトリツケイタ	LOOP HOLD SETTING PLATE	
364	018400836	2	アナボルト4X8	BOLT, SOCKET M4X8	
365	028040246	2	バネザガネ2-4	WASHER, SPRING 2-4	
366	025040236	2	ヒラザガネチユウ4	WASHER, PLAIN M 4	
367	S41592001	1	ルーフウカシイタ	LOOP HOLD PLATE	
368	018400836	2	アナボルト4X8	BOLT, SOCKET M4X8	
369	028040246	2	バネザガネ2-4	WASHER, SPRING 2-4	
370	025040236	2	ヒラザガネチユウ4	WASHER, PLAIN M 4	
371	S44975000	2	シリンダーカバー	CYLINDER COVER	
372	117936009	2	ゴムセン9.4	RUBBER CAP, 9.4	
375	S41596201	1	ルーフササエF	LOOP SUPPORT, F	
376	018400636	2	アナボルト4X6	BOLT, SOCKET M4X6	
377	028040246	2	バネザガネ2-4	WASHER, SPRING 2-4	
378	158722002	2	ザガネ4.2	WASHER, PLAIN 4.2	
380	S41604101	1	<針間隔52mm以上用> ウエガイドイタA	<For stitch interval 52mm over> UPPER GUIDE PLATE, A	
381	S41605101	1	<針間隔56mm以上用> ウエガイドイタB	<For stitch interval 56mm over> UPPER GUIDE PLATE, B	
382	018400836	2	アナボルト4X8	BOLT, SOCKET M4X8	
383	028040246	2	バネザガネ2-4	WASHER, SPRING 2-4	
384	025040236	2	ヒラザガネチユウ4	WASHER, PLAIN M 4	
385	S44964000	1	ルーフガイド1	LOOP GUIDE, 1	
386	S44965000	1	ルーフガイド2	LOOP GUIDE, 2	
387	018400836	1	アナボルト4X8	BOLT, SOCKET M4X8	
388	028040246	1	バネザガネ2-4	WASHER, SPRING 2-4	
389	025040236	1	ヒラザガネチユウ4	WASHER, PLAIN M 4	
343	S41594001	1	" オプション部品 "	" OPTION PARTS "	
344	S41595001	1	ルーフオサエ70B	LOOP PRESSER, 70B	
		1	ルーフオサエ70F	LOOP PRESSER, 70F	
373	S44974001	1	ルーフオサエ40クミ	LOOP PRESSER ASSY, 40	
373-1	S43969001	1	ルーフオサエトリツケイタSB	LOOP PRESSER SETTING PLATE, SB	
373-2	S43970001	1	ルーフオサエトリツケイタSF	LOOP PRESSER SETTING PLATE, SF	
373-3	018400836	4	アナボルト4X8	BOLT, SOCKET M4X8	
373-4	028040246	4	バネザガネ2-4	WASHER, SPRING 2-4	
373-5	025040236	4	ヒラザガネチユウ4	WASHER, PLAIN M 4	
373-6	S43967001	1	ルーフオサエ40B	LOOP PRESSER, 40B	
373-7	S43968001	1	ルーフオサエ40F	LOOP PRESSER, 40F	
373-8	018400836	4	アナボルト4X8	BOLT, SOCKET M4X8	
373-9	028040246	4	バネザガネ2-4	WASHER, SPRING 2-4	
373-10	S43963001	2	ルーフワイパーS	LOOP WIPER, S	
373-11	S43965001	1	ルーフオサエUBS	LOOP PRESSER, UBS	
373-12	S43966001	1	ルーフオサエUFS	LOOP PRESSER, UFS	
373-13	S41596201	1	ルーフササエF	LOOP SUPPORT, F	
373-14	S44964000	1	ルーフガイド1	LOOP GUIDE, 1	

D3. フィーダー関係 / Feeder mechanism / Knopfsortierer / Tricur de boutons
 / Mecanismo de botones

REF.NO.	CODE	Q'TY	ヒンメイ	NAME OF PARTS	RM
			" オプション部品 "	" OPTION PARTS "	
373-15	S44965000	1	ルーフガイド2	LOOP GUIDE, 2	
373-16	018400836	1	アナボルト4X8	BOLT, SOCKET M4X8	
373-17	028040246	1	バネザガネ2-4	WASHER, SPRING 2-4	
373-18	025040236	1	ヒラザガネチユウ4	WASHER, PLAIN M 4	

D4 . フィーダー関係 / Feeder mechanism / Knopfsortierer / Tricur de boutons / Mecanismo de botones

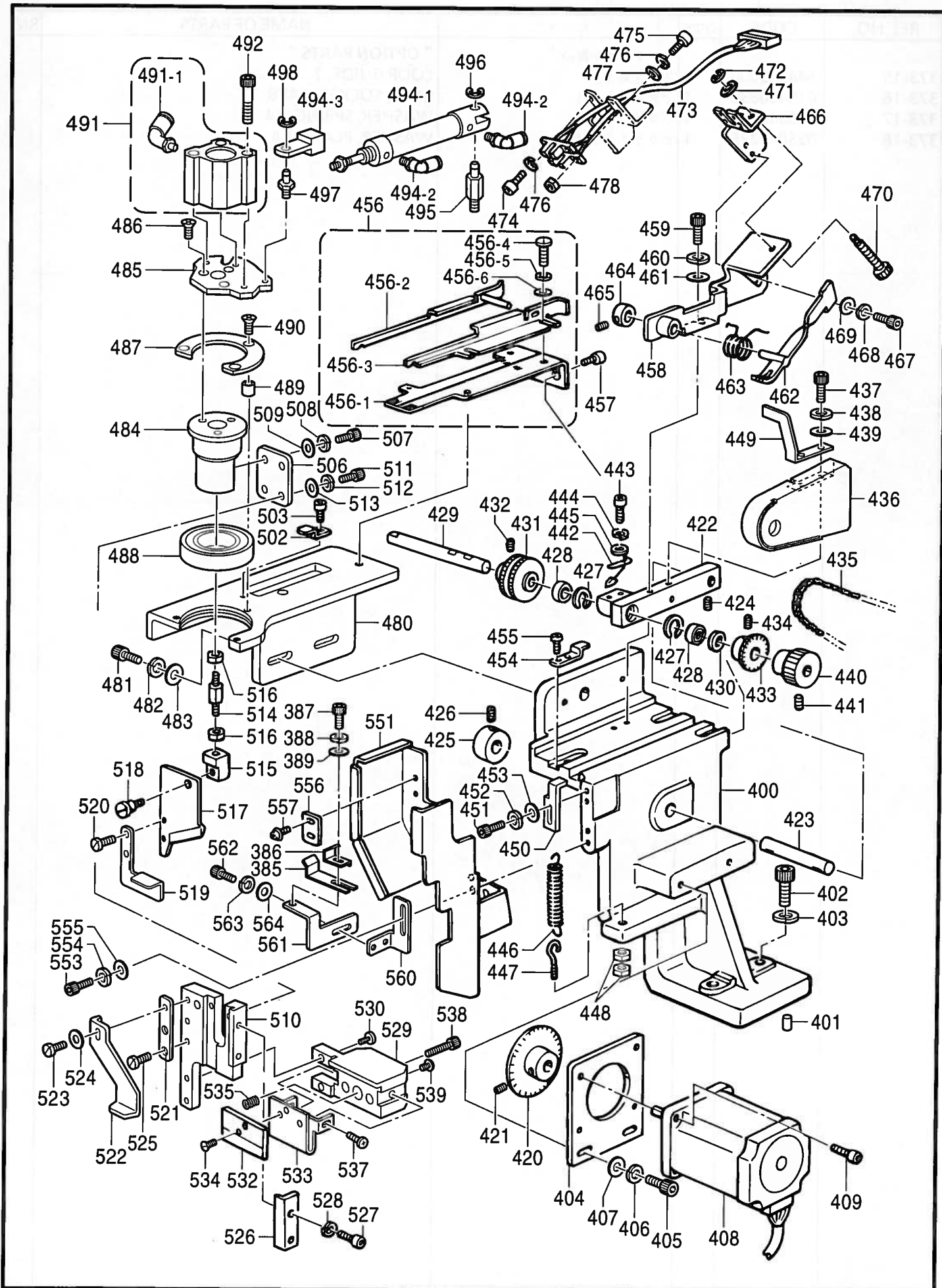

D4. フィーダー関係 / Feeder mechanism / Knopfsortierer / Tricur de boutons
/ Mecanismo de botones

REF.NO.	CODE	Q'TY	ヒンメイ	NAME OF PARTS	RM
385	S44964000	1	ループガイド1	LOOP GUIDE, 1	
386	S44965000	1	ループガイド2	LOOP GUIDE, 2	
387	018400836	1	アナボルト4X8	BOLT, SOCKET M4X8	
388	028040246	1	バネザガネ2-4	WASHER, SPRING 2-4	
389	025040236	1	ヒラザガネチユウ4	WASHER, PLAIN M 4	
400	S41621001	1	ユニットダイ	UNIT BASE	
401	156958001	2	スイヘイオクリウデジク	FEED ROCK ARM STUD	
402	018062536	2	アナボルト6X25	BOLT, SOCKET M6X25	
403	028060246	2	バネザガネ2-6	WASHER, SPRING 2-6	
404	S41597001	1	モータトリツケイタ	MOTOR SETTING PLATE	
405	018501236	2	アナボルト5X12	BOLT, SOCKET M5X12	
406	028050246	2	バネザガネ2-5	WASHER, SPRING 2-5	
407	025050236	2	ヒラザガネチユウ5	WASHER, PLAIN M 5	
408	S41598000	1	ハルスモータクミ	PULSE MOTOR ASSY	
409	018401036	4	アナボルト4X10	BOLT, SOCKET M4X10	
420	S41600000	1	スプロケットB	SPROCKET WHEEL, B	
421	012400436	2	アナヒラ4X4	SET SCREW, SOCKET (FT) M4X4	
422	S23696101	1	オクリローラーム	FEED ROLLER ARM	
423	S14924001	1	ローラシテングク	ROLLER FULCRUM SHAFT	
424	012400436	1	アナヒラ4X4	SET SCREW, SOCKET (FT) M4X4	
425	S07129001	1	セツトカラー	SET SCREW COLLAR	
426	014060622	2	アナトメネジ6X6クボミ	SET SCREW, SOCKET (CP) M6X6	
427	048130242	2	トメワアナヨウC13	RETAINING RING, C13	
428	S14919000	2	タマジクウケ1360ZZ	BALL BEARING, 1360ZZ	
429	S23697001	1	ローラジク	ROLLER SHAFT	
430	S23698001	1	スヘーサ	SPACER	
431	S23699201	1	オクリローラ	FEED ROLLER	
432	012400436	2	アナヒラ4X4	SET SCREW, SOCKET (FT) M4X4	
433	S14920000	1	スプロケットA	SPROCKET WHEEL, A	
434	012400436	2	アナヒラ4X4	SET SCREW, SOCKET (FT) M4X4	
435	S41602000	1	チェーン	CHAIN	
436	S41603101	1	スプロケットカバー	SPROCKET WHEEL COVER	
437	018400836	2	アナボルト4X8	BOLT, SOCKET M4X8	
438	028040246	2	バネザガネ2-4	WASHER, SPRING 2-4	
439	026040136	2	ヒラザガネコガタ4	WASHER, PLAIN S 4	
440	S15700009	1	ツマミ	KNOB	
441	014680422	2	アナトメネジ4.37クボミ	SET SCREW, SOCKET (CP) SM4.37	
442	S41606100	1	オクリローラガイド	FEED ROLLER GUIDE	
443	018401036	2	アナボルト4X10	BOLT, SOCKET M4X10	
444	028040246	2	バネザガネ2-4	WASHER, SPRING 2-4	
445	025040236	2	ヒラザガネチユウ4	WASHER, PLAIN M 4	
446	159114001	1	カッタモドシバネ	SPRING	
447	140947002	1	ウワイタチヨウセツネジ	ADJUSTING SCREW	
448	021400202	2	2シユナツト4	NUT, 2 M4	
449	S41925101	1	ホジヨレバー	SUB LEVER	
450	S14958101	1	ローラストツバ	ROLLER STOPPER	
451	018401036	2	アナボルト4X10	BOLT, SOCKET M4X10	
452	028040246	2	バネザガネ2-4	WASHER, SPRING 2-4	
453	025040236	2	ヒラザガネチユウ4	WASHER, PLAIN M 4	
454	S23701101	1	チャンネルウケ	CHANNEL SUPPORT	
455	062400816	2	ナベコ4X8	SCREW, PAN M4X8	
456	S23702201	1	チャンネルクミ	CHANNEL ASSY	
456-1	S23703101	1	チャンネルベースL	CHANNEL BASE, L	
456-2	S41926001	1	チャンネルB	CHANNEL, B	
456-3	S41927001	1	チャンネルF	CHANNEL, F	
456-4	060300516	4	バインド3X5	SCREW, BIND M3X5	
456-5	028030246	4	バネザガネ2-3	WASHER, SPRING 2-3	
456-6	105161004	4	ザガネ	WASHER	
457	018401036	2	アナボルト4X10	BOLT, SOCKET M4X10	

D4 . フィーダー関係 / Feeder mechanism / Knopfsortierer / Tricur de boutons
/ Mecanismo de botones

REF.NO.	CODE	Q'TY	ヒンメイ	NAME OF PARTS	RM
458	S14946101	1	ツギメセンサダイ	JOINT SENSOR BASE	
459	018401036	2	アナボルト4X10	BOLT, SOCKET M4X10	
460	028040246	2	バネザガネ2-4	WASHER, SPRING 2-4	
461	025040236	2	ヒラザガネチユウ4	WASHER, PLAIN M 4	
462	S14949101	1	ツギメアクチュエータ	JOINT ACTUATOR	
463	S14950001	1	アクチュエータバネ	SPRING	
464	149864051	1	セツトカラー	SET SCREW COLLAR	
465	100402004	2	トメネジ3.57	SET SCREW, SM3.57	
466	S14947101	1	ツギメセンサダイ	JOINT SENSOR BASE	
467	018400836	2	アナボルト4X8	BOLT, SOCKET M4X8	
468	028040246	2	バネザガネ2-4	WASHER, SPRING 2-4	
469	025040236	2	ヒラザガネチユウ4	WASHER, PLAIN M 4	
470	S14948101	1	チヨウセツジク6	ADJUST SHAFT, 6	
471	025040236	1	ヒラザガネチユウ4	WASHER, PLAIN M 4	
472	048030346	1	トメワE3	RETAINING RING, E3	
473	S40518000	1	ループセンサクミ	LOOP SENSOR ASSY	
474	018300636	2	アナボルト3X6	BOLT, SOCKET M3X6	
475	018301236	2	アナボルト3X12	BOLT, SOCKET M3X12	
476	028030246	4	バネザガネ2-3	WASHER, SPRING 2-3	
477	025030236	2	ヒラザガネチユウ3	WASHER, PLAIN M 3	
478	021300103	2	ナツト1シユ3	NUT, 1 M3	
480	S47399009	1	カッタユニットダイ	KNIFE UNIT BASE	
481	018501636	2	アナボルト5X16	BOLT, SOCKET M5X16	
482	028050246	2	バネザガネ2-5	WASHER, SPRING 2-5	
483	025050236	2	ヒラザガネチユウ5	WASHER, PLAIN M 5	
484	S47393001	1	メスカイテンダイ	KNIFE ROTATION BASE	
485	S47394001	1	メスカイテンダイ2	KNIFE ROTATION BASE, 2	
486	004400814	3	+サラコ4X8	SCREW, FLAT M4X8	
487	S47369001	1	ベアリングオサエ	BEARING PRESSER	
488	076805800	1	タマジクウケ6805	BALL BEARING, 6805	
489	154514001	3	スヘーサ	SPACER	
490	004401414	3	+サラコ4X14	SCREW, FLAT M4X14	
491	S47398000	1	シリンダ25X15クミ	CYLINDER ASSY, 25X15	
491-1	S23741000	2	エルボユニオン4M5	ELBOW UNION, 4M5	
492	018503536	3	アナボルト5X35	BOLT, SOCKET M5X35	
494	S41609000	1	シリンダ16X30クミ	CYLINDER ASSY, 16X30	
494-1	S24175000	1	シリンダ16X30	CYLINDER, 16X30	
494-2	S11426000	2	エルボユニオン4M5	ELBOW UNION, 4M5	
494-3	S37454000	1	1ヤマナツクルジョイント	KNUCLE JOINT	
495	S41610001	1	シテンジク2	FULCRUM SHAFT, 2	
496	048050142	1	トメワジクヨウC5	RETAINING RING, C5	
497	S41611001	1	シテンジク	FULCRUM SHAFT	
498	048050142	1	トメワジクヨウC5	RETAINING RING, C5	
502	S41612001	1	メスストツバ	KNIFE STOPPER	
503	018400836	1	アナボルト4X8	BOLT, SOCKET M4X8	
506	S47395001	1	メスダイレンケツイタ	KNIFE BASE CONNECTING PLATE	
507	018401036	2	アナボルト4X10	BOLT, SOCKET M4X10	
508	028040246	2	バネザガネ2-4	WASHER, SPRING 2-4	
509	025040236	2	ヒラザガネチユウ4	WASHER, PLAIN M 4	
510	S43997001	1	メスダイ	KNIFE BASE	
511	018401136	2	アナボルト4X10	BOLT, SOCKET M4X10	
512	028040246	2	バネザガネ2-4	WASHER, SPRING 2-4	
513	025040236	2	ヒラザガネチユウ4	WASHER, PLAIN M 4	
514	S41613001	1	メスレンケツボウ	KNIFE CONNECTING BAR	
515	S14935001	1	メスジョイント	JOINT	
516	021500102	2	ナツト1シユ5	NUT, 1 M5	
517	S23709001	1	イドウハ	MOVABLE KNIFE	
518	148417001	1	ダンネジ4.37	SHOULDER SCREW, SM4.37	
519	S41915001	1	ルーフササエ	LOOP SUPPORT	

D4. フィーダー関係 / Feeder mechanism / Knopfsortierer / Tricur de boutons
/ Mecanismo de botones

REF.NO.	CODE	Q'TY	ヒンメイ	NAME OF PARTS	RM
520	105288001	2	シメネジ2.38	SCREW, SM2.38	
521	S43998001	1	イドウハアンナイ	MOVABLE KNIFE GUIDE	
522	S41615001	1	ループササエT	LOOP SUPPORT, T	
523	S13385001	1	シメネジ3.57X10	SCREW, SM3.57X10	
524	025350236	1	ヒラザガネチユウ3.5	WASHER, PLAIN M 3.5	
525	100257010	2	シメネジ3.57	SCREW, SM3.57	
526	S27853001	1	イドウハオサエ	MOVABLE KNIFE PRESSER	
527	018300822	2	アナボルト3X8	BOLT, SOCKET M3X8	
528	028030242	2	バネザガネ2-3	WASHER, SPRING 2-3	
529	S43999001	1	コテイホルダベース	FIXED KNIFE HOLDER BASE	
530	S13385001	2	シメネジ3.57X10	SCREW, SM3.57X10	
532	S23714001	1	コテイハ	FIXED KNIFE	
533	S44000000	1	コテイハホルダー	FIXED KNIFE HOLDER	
534	141542001	2	サラネジ3.18	SCREW, FLAT SM3.18	
535	S35020001	1	スプレダーバネ	SPREADER SPRING	
537	060400816	2	バインド4X8	SCREW, BIND M4X8	
538	018401422	2	アナボルト4X14	BOLT, SOCKET M4X14	
539	008400604	2	+トラスコ4X6	SCREW, TRUSS M4X6	
551	S41601101	1	キリクズカバーA	CLIPPING DISPOSAL COVER, A	
553	018401236	2	アナボルト4X12	BOLT, SOCKET M4X12	
554	028040246	2	バネザガネ2-4	WASHER, SPRING 2-4	
555	025040236	2	ヒラザガネチユウ4	WASHER, PLAIN M 4	
556	S23794001	1	キリクズカバーB	CLIPPING DISPOSAL COVER, B	
557	052300606	2	ナベコバネヒラ3X6	SCREW, PAN (S/P WASHER) M3X6	
560	S44966001	1	ループササエB1	LOOP SUPPORT, B1	
561	S44967001	1	ループササエB2	LOOP SUPPOER, B2	
562	018400836	2	アナボルト4X8	BOLT, SOCKET M4X8	
563	028040246	2	バネザガネ2-4	WASHER, SPRING 2-4	
564	025040236	2	ヒラザガネチユウ4	WASHER, PLAIN M 4	

D5 . フィーダー関係 (オプション部品) / Feeder mechanism (Option parts)
/ Knopfsortierer (Sonderzubehör) / Tricur de boutons (Pièces en option)
/ Mecanismo de botones (Piezas opcionales)

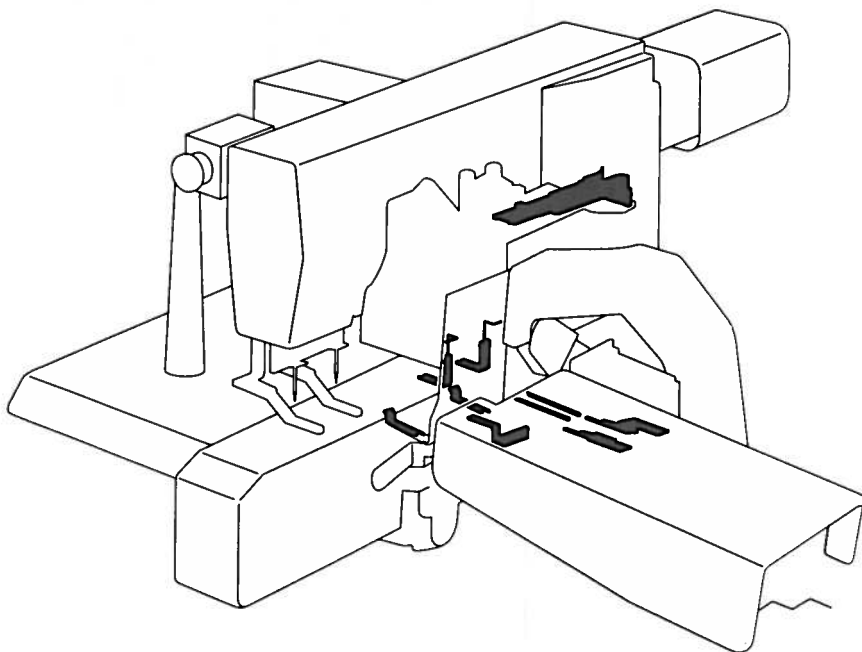
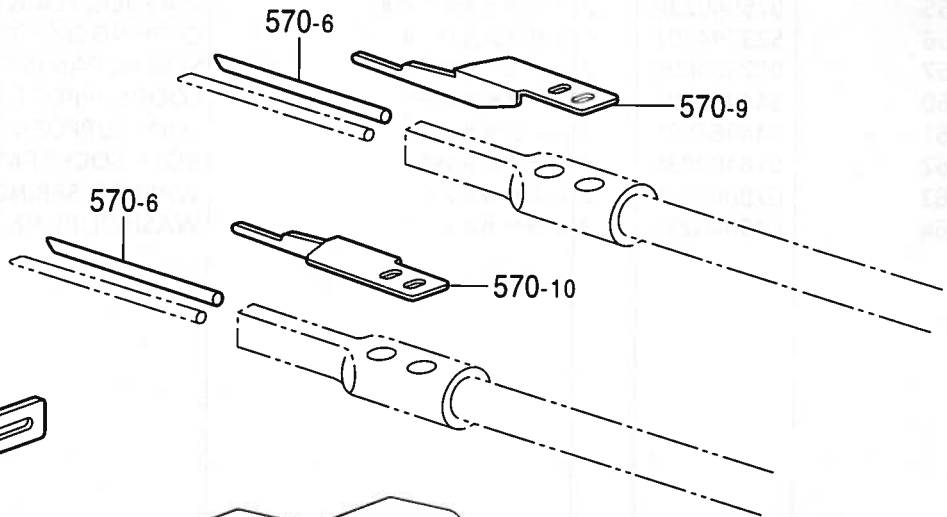
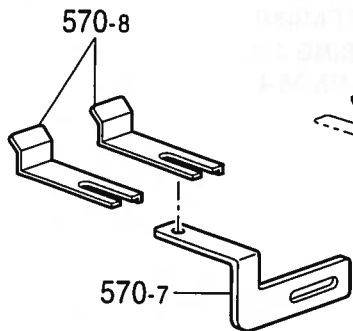
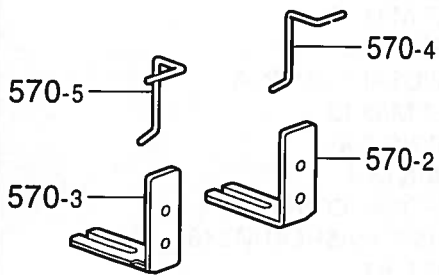
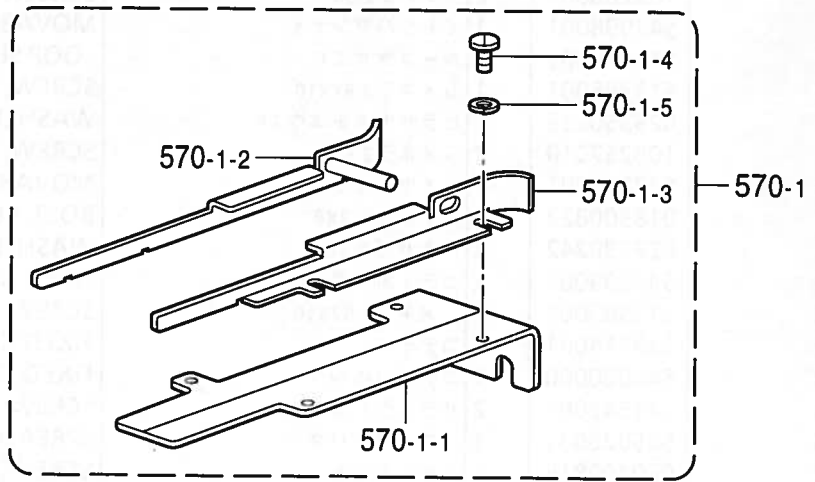

D5. フィーダー関係 (オプション部品) / Feeder mechanism (Option parts)
 / Knopfsortierer (Sonderzubehör) / Tricur de boutons (Pièces en option)
 / Mecanismo de botones (Piezas opcionales)

REF.NO.	CODE	Q'TY	ヒンメイ	NAME OF PARTS	RM
			<ループ幅25.4mm平カット専用>	<Using the loop width 25.4mm for flat cut only>	
570	S47058001	1	1インチゲージセット	GAUGE SET, 1	
570-1	S44983001	1	チャンネルクミ25	CHANNEL ASSY, 25	
570-1-1	S44984001	1	チャンネルベース25	CHANNEL BASE, 25	
570-1-2	S44985001	1	チャンネルB25	CHANNEL, BACK 25	
570-1-3	S44986001	1	チャンネルF25	CHANNEL, FRONT 25	
570-1-4	060300516	4	バインド3X5	SCREW, BIND M3X5	
570-1-5	028030246	4	バネザガネ2-3	WASHER, BIND 2-3	
570-2	S44987001	1	ループオサエBL	LOOP PRESSER, BL	
570-3	S44988001	1	ループオサエFL	LOOP PRESSER, FL	
570-4	S44989001	1	ハバヨセバネBL	SPRING, WIDE NARROW (BL)	
570-5	S44990001	1	ハバヨセバネFL	SPRING, WIDE NARROW (FL)	
570-6	S41919001	2	ホークジク2.0LL	FORK SHAFT, 2.0LL	
570-7	S47528001	1	ループササエB2L	LOOP SUPPORT, B2L	
570-8	S47529001	2	ループガイド1L	LOOP GUIDE, 1L	
570-9	S47553001	1	ユルメオサエBL	LOOSEN PRESSER FOOT, BL	
570-10	S47554001	1	ユルメオサエFL	LOOSEN PRESSER FOOT, FL	

E . 下軸関係 / Lower shaft mechanism / Untere Welle / Mécanisme de l'arbre inférieur
/ Mecanismo del eje inferior

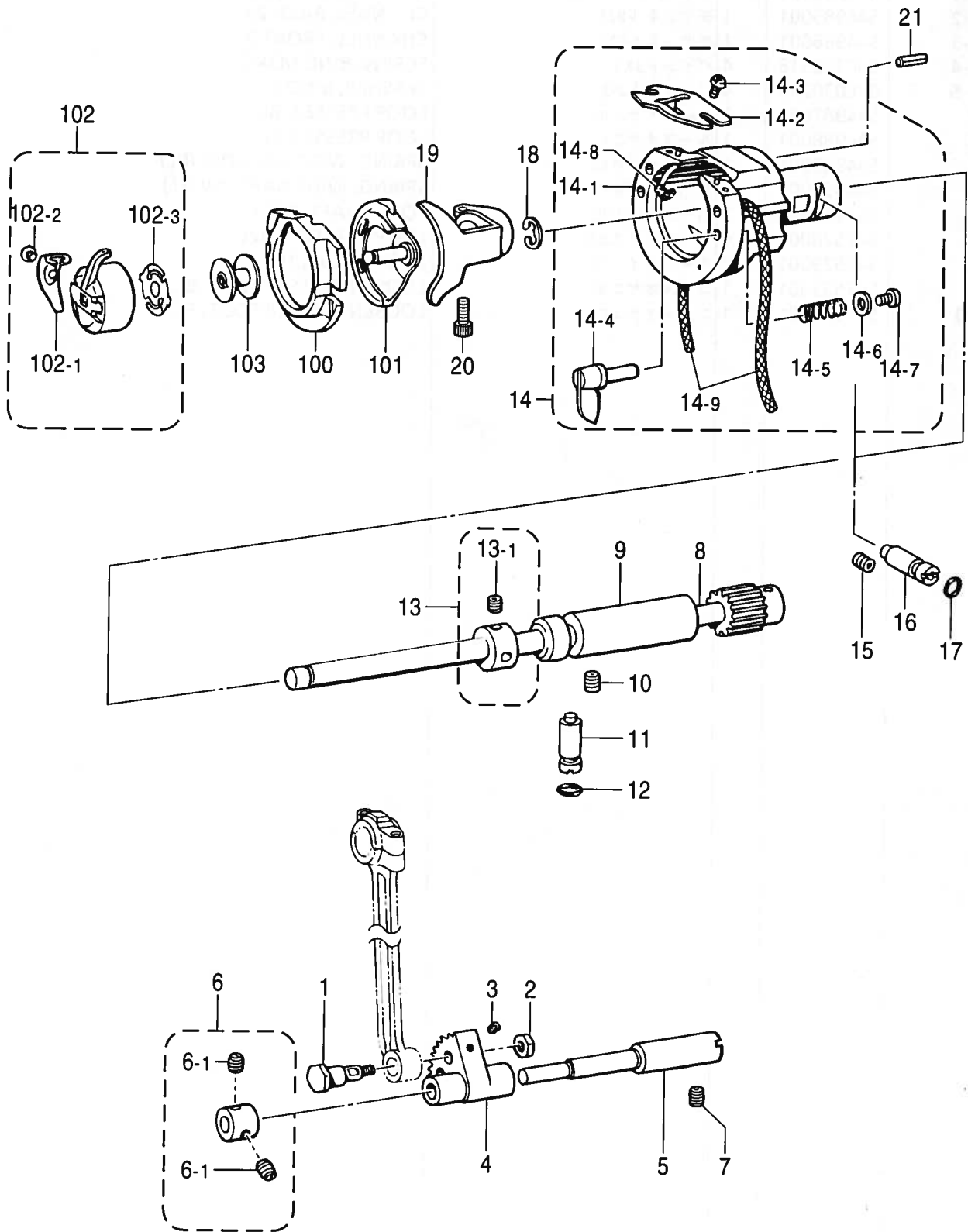

E. 下軸関係 / Lower shaft mechanism / Untere Welle / Mécanisme de l'arbre inférieur
/ Mecanismo del eje inferior

REF.NO.	CODE	Q'TY	ヒンメイ	NAME OF PARTS	RM
1	141786001	1	クランクロッドダンネジ	SHOULDER SCREW, CRANK ROD	
2	100090004	1	ナット7.14	NUT, SM7.14	
3	014680622	1	アナトメネジ4.37クボミ	SET SCREW, SOCKET (CP) SM4.37	
4	152245001	1	ヨウドウギヤ	ROCK GEAR	
5	S37978151	1	ヨウドウギヤジク	ROCK GEAR SHAFT	
6	181995001	1	セツトカラークミ	SET SCREW COLLAR ASSY	
6-1	101706001	2	トメネジ6.35	SET SCREW, SM6.35	
7	014760622	1	アナトメネジ5.95	SET SCREW, SOCKET SM5.95	
8	S41710001	1	シタジククミ	LOWER SHAFT ASSY	
9	S37981051	1	シタジクメタル	LOWER SHAFT BUSH	
10	014760622	1	アナトメネジ5.95	SET SCREW, SOCKET SM5.95	
11	152678001	1	カマチヨウセツジク	ADJUSTING STUD	
12	081003670	1	OリングPW3	O RING, PW3	
13	S03704002	1	セツトカラークミ	SET SCREW COLLAR ASSY	
13-1	014770622	2	アナトメネジ6.35クボミ	SET SCREW, SOCKET (CP) SM6.35	
14	S41717001	1	オオカマタイクミ	SHUTTLE RACE BASE ASSY	
14-1	S02428001	1	オオカマタイ	SHUTTLE RACE BASE	
14-2	S41718001	1	カマイトアンナイA	SHUTTLE RACE THREAD GUIDE	
14-3	062660412	2	ナベコ318-40X4	SCREW, PAN SM3.18-40X4	
14-4	152683001	2	オオカマトリツケツメ	SHUTTLE RACE BODY SETTING CLAW	
14-5	152684101	2	オオカマトリツケバネ	SPRING, COMPRESSION	
14-6	402887001	2	ザガネ3.2	WASHER, 3.2	
14-7	062660712	2	ナベコ318-40X7	SCREW, PAN SM3.18-40X7	
14-8	153050000	2	オオカマタイフェルト	SHUTTLE RACE BASE FELT	
14-9	S02877000	2	クミヒモ4X4	WICK, 4X4 (L = 350)	
15	014760622	1	アナトメネジ5.95	SET SCREW, SOCKET SM5.95	
16	152678001	1	カマチヨウセツジク	ADJUSTING STUD	
17	081003670	1	OリングPW3	O RING, PW3	
18	048080342	1	トメワE8	RETAINING RING, E8	
19	S41712001	1	ドライバー	DRIVER	
20	018501422	1	アナボルト5X14	BOLT, SOCKET M5X14	
21	120438001	1	ミゾツキピン	PIN, DOWEL	
100	S41714101	1	オオカマD	SHUTTLE RACE BODY, D	
101	S41713901	1	ナカカマLDハコクミ	SHUTTLE HOOK BOX ASSY, LD	
102	S18974101	1	ボビンケースクミLAN	BOBBIN CASE ASSY, LAN	
102-1	S16074101	1	ケースチヨウシバネA	TENSION SPRING, A	
102-2	S16492101	1	ボビンケースバネネジ	SCREW, BOBBIN CASE SPRING	
102-3	S15667001	1	クウテンボウシバネ	SPRING, ANTI-SPIN	
103	S15665001	1	ボビンLA	BOBBIN, LA	

F. 下軸モジュール関係 / Lower shaft module mechanism / Module für untere Welle
 / Mécanisme de module d'arbre inférieur / Mecanismo de módulo de eje inferior

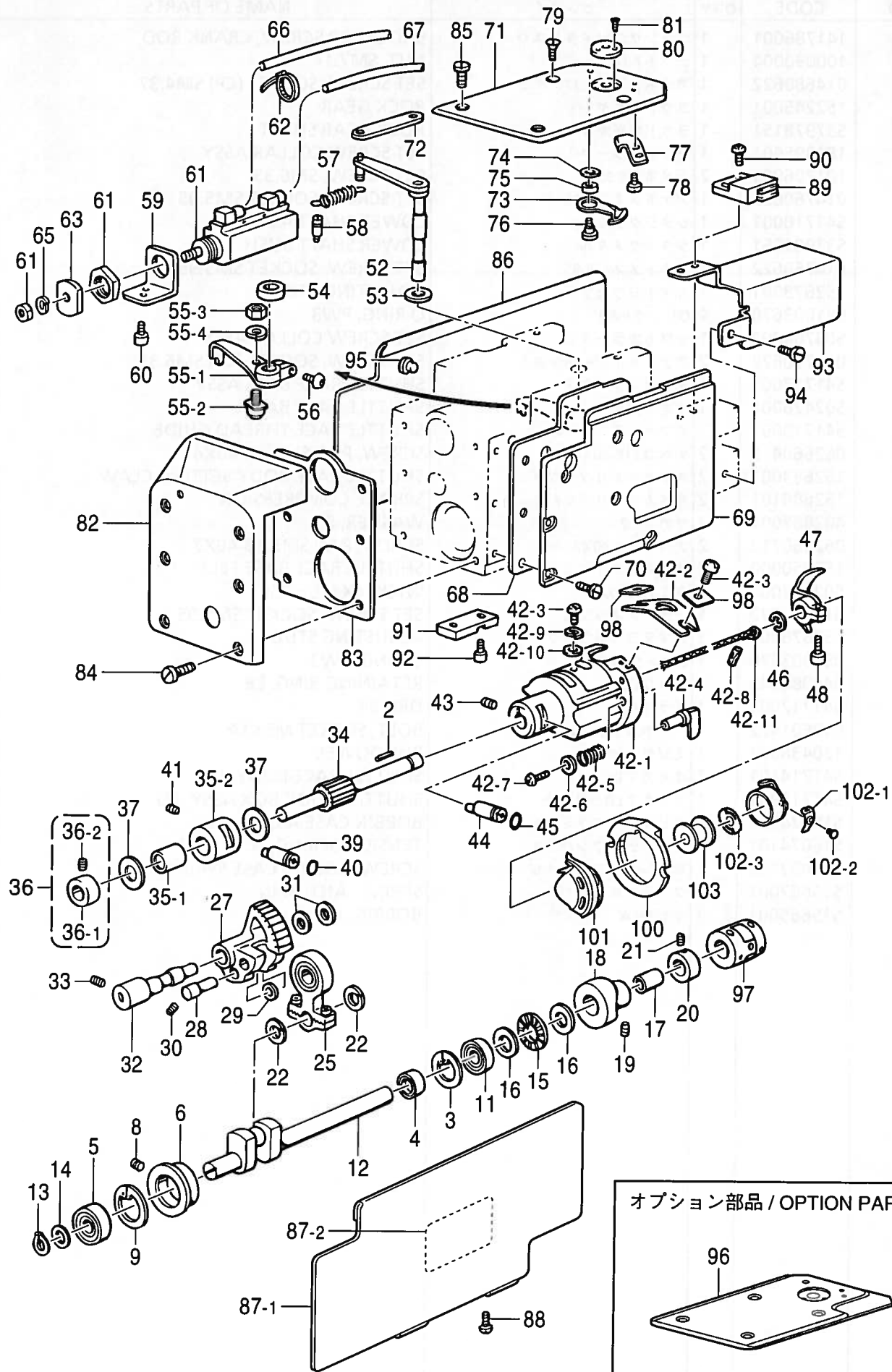

F. 下軸モジュール関係 / Lower shaft module mechanism / Module für untere Welle
/ Mécanisme de module d' arbre inférieur / Mecanimo de módulo de eje inferior

REF.NO.	CODE	Q'TY	ヒンメイ	NAME OF PARTS	RM
2	120438001	1	ミソツキピン	PIN, DOWEL	
3	048260242	1	トメワアナヨウC26	RETAINING RING, C26	
4	S41808000	1	オイルシール	OIL SEAL	
5	072600080	1	タマジクウケ 6000ZZ	BALL BEARING, 6000ZZ	
6	S41809000	1	タマジクウケケース	BALL BEARING CASE	
8	012500536	1	アナヒラ5X5	SET SCREW, SOCKET (FT) M5X5	
9	048260242	1	トメワアナヨウC26	RETAINING RING, C26	
11	072600080	1	タマジクウケ 6000ZZ	BALL BEARING, 6000ZZ	
12	S41810001	1	BMクランクジク	BM-CRANK SHAFT	
13	048100142	1	トメワジクヨウC10	RETAINING RING, C10	
14	S09027001	1	ヒラザガネシヨウ10	WASHER, PLAIN S 10	
15	072512260	1	スラストベアリング	THRUST BEARING	
16	S41811000	2	スラストザガネ	WASHER, THURST	
17	S41812001	1	カムスリーブ	CAM SLEEVE	
18	S41813001	1	イトキリカム	THREAD TRIMMING CAM	
19	013719412	2	トメネジ4.76クボミ	SET SCREW, (CP) SM4.76	
20	150594001	1	セットカラー	SET SCREW COLLAR	
21	014760622	2	アナトメネジ5.95	SET SCREW, SOCKET SM5.95	
22	S41814000	2	ロッドフレドメ1.6	ROD STOPPER, 1.6	
25	S41815001	1	BMクランクロッドクミ	BM-CRANK ROD ASSY	
27	S41819001	1	ヨウドウギヤ	ROCK GEAR	
28	S41820001	1	チヨウシンジク	BUSHING	
29	122257001	1	ザガネ	WASHER	
30	151602002	2	トメネジ4.37	SET SCREW, SM4.37	
31	153596001	2	ザガネ	WASHER	
32	S41821001	1	ヨウドウギヤジク	ROCK GEAR SHAFT	
33	012500536	1	アナヒラ5X5	SET SCREW, SOCKET (FT) M5X5	
34	S41822001	1	カマジク	SHUTTLE HOOK SHAFT	
35	S41823001	1	カマジクメタルクミ	SHUTTLE HOOK SHAFT BUSH. ASSY	
35-1	S13744001	1	ニードルジクウケ9.53	NEEDLE BEARING, 9.53	
35-2	S41824001	1	カマジクメタル	SHUTTLE HOOK SHAFT BUSHING	
36	S03490001	1	セットカラークミ	SET SCREW COLLAR ASSY	
36-1	115127001	1	セットカラー	SET SCREW COLLAR	
36-2	013710512	2	トメネジ4.76クボミ	SET SCREW, (CP) SM4.76	
37	S41805001	2	スラストザガネ	WASHER, THRUST	
39	152678001	1	カマチヨウセツジク	ADJUSTING STUD	
40	081003670	1	リングPW3	O RING, PW3	
41	012500536	1	アナヒラ5X5	SET SCREW, SOCKET (FT) M5X5	
42	S41825001	1	オオカマタイBMクミ	SHUTTLE RACE BASE ASSY, BM	
42-1	S41826001	1	オオカマタイBM	SHUTTLE RACE BASE, BM	
42-2	S41718001	1	カマイトアンナイA	SHUTTLE RACE THREAD GUIDE	
42-3	062660412	3	ナベコ318-40X4	SCREW, PAN SM3.18-40X4	
42-4	152683001	2	オオカマトリツケツメ	SHUTTLE RACE BODY SETTING CLAW	
42-5	152684101	2	オオカマトリツケバネ	SPRING, COMPRESSION	
42-6	402887001	2	ザガネ3.2	WASHER, 3.2	
42-7	062660712	2	ナベコ318-40X7	SCREW, PAN SM3.18-40X7	
42-8	153050000	2	オオカマタイフェルト	SHUTTLE RACE BASE FELT	
42-9	028350243	1	バネザガネ2-3.5	WASHER, SPRING 2-3.5	
42-10	025030335	1	ヒラザガネダイ3	WASHER, PLAIN L 3	
42-11	S02877000	2	クミヒモ4X4	WICK, 4X4 (L = 350)	
43	012500536	1	アナヒラ5X5	SET SCREW, SOCKET (FT) M5X5	
44	152678001	1	カマチヨウセツジク	ADJUSTING STUD	
45	081003670	1	リングPW3	O RING, PW3	
46	048080342	1	トメワE8	RETAINING RING, E8	
47	S41712001	1	ドライバー	DRIVER	
48	018501422	1	アナボルト5X14	BOLT, SOCKET M5X14	
52	S41829001	1	イトキリレバージク	THREAD TRIMMER LEVER SHAFT	
53	153596001	1	ザガネ	WASHER	
54	148239001	1	ゼンゴジクカラー	THRUST COLLAR	

F. 下軸モジュール関係 / Lower shaft module mechanism / Module für untere Welle
 / Mécanisme de module d'arbre inférieur / Mecanismo de módulo de eje inferior

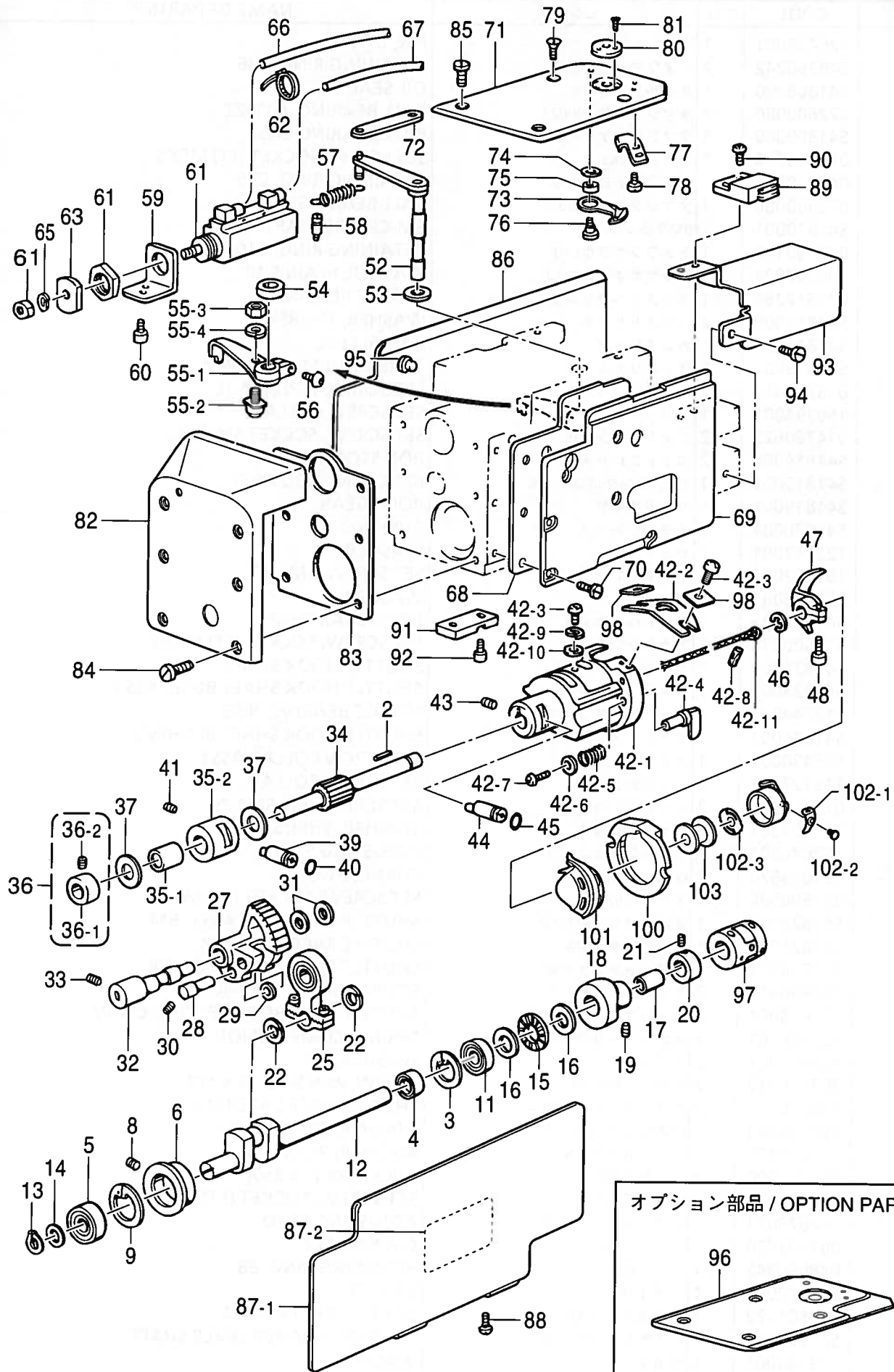

F. 下軸モジュール関係 / Lower shaft module mechanism / Module für untere Welle
/ Mécanisme de module d' arbre inférieur / Mecanimo de módulo de eje inferior

REF.NO.	CODE	Q'TY	ヒンメイ	NAME OF PARTS	RM
55	S41830001	1	イトキリレバークミ	THREAD TRIMMER LEVER ASSY	
55-1	S41831001	1	イトキリレバー	THREAD TRIMMER LEVER	
55-2	154590001	1	コロジクCクミ	ROLLER SHAFT ASSY, C	
55-3	105234003	1	ナツト4.37	NUT, SM4.37	
55-4	028680242	1	バネザガネ2-4.37	WASHER, SPRING 2-4.37	
56	S41850001	1	ボタンヘッドネジ5X14	SCREW, BUTTON HEAD M5X14	
57	S41832001	1	イトキリバネ	SPRING, THREAD TRIMMER	
58	107657001	1	バネカケ	SPRING HOOK	
59	S41833001	1	イトキリシリンドルトリツケイタ	SETTING PLATE, TR CYLINDER	
60	018400636	2	アナボルト4X6	BOLT, SOCKET M4X6	
61	S41834000	1	イトキリシリンドクミ	THREAD TRIMMER CYLINDER ASSY	
62	228475000	1	ケツソクバンド1.9X80	FASTENING BAND, 1.9X80	
63	S41836001	1	イトキリレバーサドウイタ	TR LEVER DRIVING PLATE	
65	028050246	1	バネザガネ2-5	WASHER, SPRING 2-5	
66	S41943000	1	エアホース0425S145B	AIR TUBE, 0425S (L = 1450)	
67	S31706000	1	エアチューブ4X1510	AIR TUBE, 4X1510	
68	S41837000	1	BMハツキン	BM-PACKING	
69	S41838001	1	BMサイドカバー	BM-SIDE COVER	
70	106629002	6	シメネジ4.37	SCREW, SM4.37	
71	S41839001	1	BMハリイタ	BM-NEEDLE PLATE	
72	S41840001	1	イトキリレンカン	THREAD TRIMMER CONNECTING ROD	
73	S10205001	1	イドウハクミ	MOVABLE KNIFE ASSY	
74	S10208001	1	イドウハカンザ <t=0.4>	WASHER, MOVABLE KNIFE T = 0.4 <t = 0.4>	
74	S10208002	1	イドウハカンザ <t=0.5>	WASHER, MOVABLE KNIFE T = 0.5 <t = 0.5>	
74	S10208003	1	イドウハカンザ <t=0.6>	WASHER, MOVABLE KNIFE T = 0.6 <t = 0.6>	
75	S00705001	1	イドウハカラー	MOVABLE KNIFE COLLAR	
76	S10209101	1	シメネジ4.37	SCREW, SM4.37	
77	S41738001	1	コテイハ	FIXED KNIFE	
78	111140002	2	シメネジ2.38	SCREW, SM2.38	
79	100032004	2	サラネジ4.37	SCREW, FLAT SM4.37	
80	S10212101	1	ハリアナイタE	NEEDLE HOLE PLATE, E	
81	100360003	2	サラネジ2.38	SCREW, FLAT SM2.38	
82	S41841109	1	BMフロントカバー	BM-FRONT COVER	
83	S41842000	1	フロントハツキン	FRONT PACKING	
84	106629002	6	シメネジ4.37	SCREW, SM4.37	
85	153208002	2	シメネジ4.37	SCREW, SM4.37	
86	S41843009	1	BMカバーR	BM-COVER, R	
87-1	S41844009	1	BMカバーL	BM-COVER, L	
87-2	S45721001	1	カマセイソウラベル	LABEL, CLEANING	
88	060300416	8	バインド3X4	SCREW, BIND M3X4	
89	S41845000	2	マグネットキャッチ	MAGNET CATCH	
90	060300612	4	バインド M3X6	SCREW, BIND M3X6	
91	S41846001	1	キー18	KEY, 18	
92	018400636	2	アナボルト4X6	BOLT, SOCKET M4X6	
93	S41847009	1	BMモータカバー	BM-MOTOR COVER	
94	106629002	1	シメネジ4.37	SCREW, SM4.37	
95	S41848000	4	ゴムセン6.6	RUBBER CAP, 6.6	
97	S41849000	1	カツプリング8	COUPLING, 8	
98	S44773101	2	マワリドメイタ	STOPPER PLATE	
100	S41714101	1	オオカマD	SHUTTLE RACE BODY, D	
101	S41713901	1	ナカカマLDハコクミ	SHUTTLE HOOK BOX ASSY, LD	
102	S18974101	1	ボビンケースクミLAN	BOBBIN CASE ASSY, LAN	
102-1	S16074101	1	ケースチヨウシバネA	TENSION SPRING, A	
102-2	S16492101	1	ボビンケースバネネジ	SCREW, BOBBIN CASE SPRING	
102-3	S15667001	1	クウテンボウシバネ	SPRING, ANTI-SPIN	
103	S15665001	1	ボビンLA	BOBBIN, LA	
96	S46563001	1	" オプション部品 " BMハリイタE	" OPTION PARTS " NEEDLE PLATE, E BM	

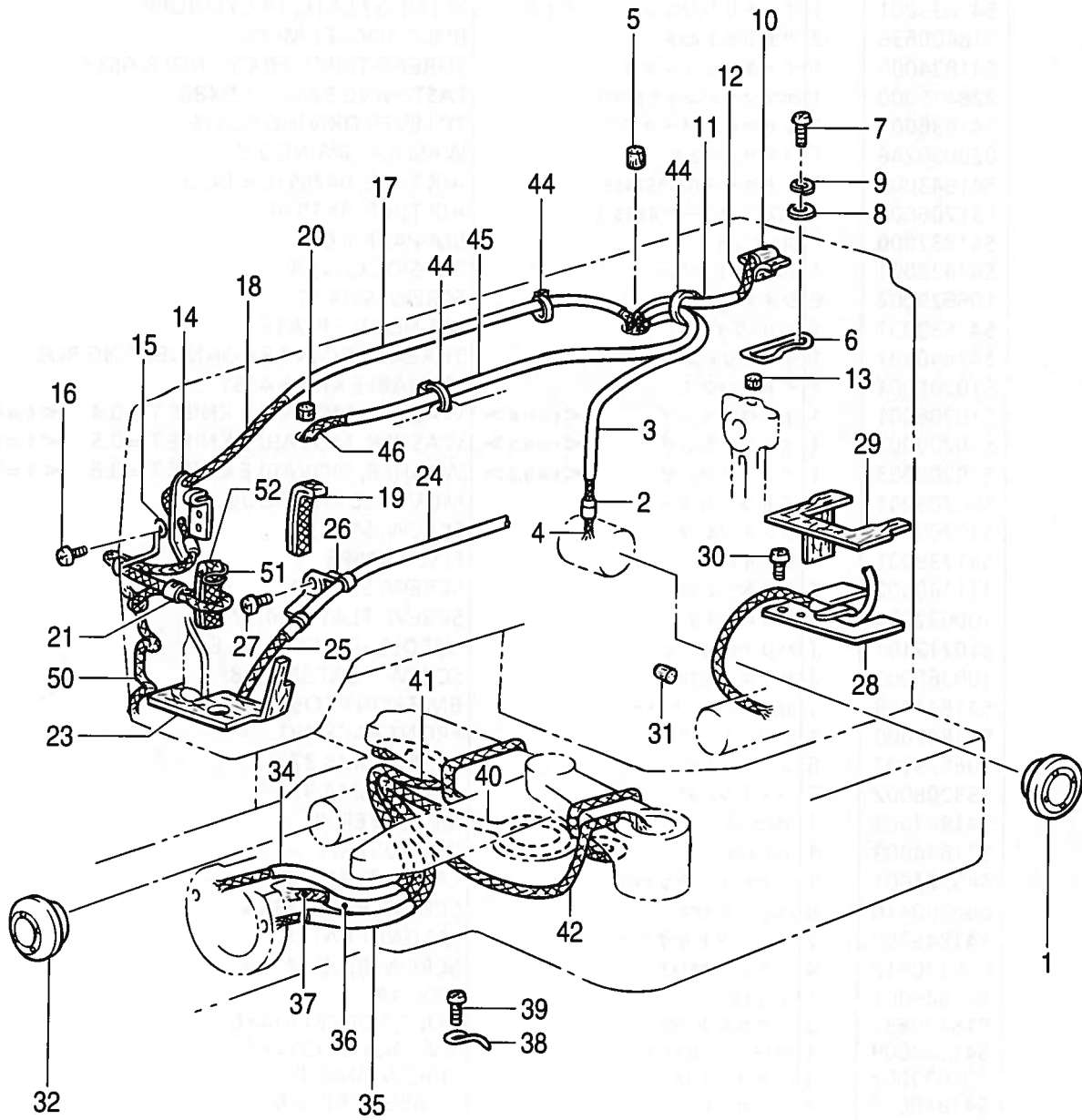

G1 . 給油潤滑関係 / Lubrication / Schmierung / Lubrification / Lubricación

REF.NO.	CODE	Q'TY	ヒンメイ	NAME OF PARTS	RM
1	152948001	1	オイルボツトマド	OIL WINDOW	
2	S07333001	1	オイルクチパイプS	OIL FEEDING PIPE, S	
3	S07456000	1	ビニールチューブ	OIL TUBE, L = 160	
4	148738000	1	クミヒモ	WICK, L = 335	
5	107149001	1	フェルト	FELT	
6	S37983001	1	ウワジクキユウユササエ	WICK SUPPORT	
7	062680612	1	ナベコ4.37-40X6	SCREW, PAN SM4.37-40X6	
8	025680232	1	ヒラザガネチユウ4.37	WASHER, PLAIN M 4.37	
9	028680242	1	バネザガネ2-4.37	WASHER, SPRING 2-4.37	
10	S10478000	1	ロツドキユウユフェルト	FELT	
11	S34986000	1	ビニルチューブ	OIL TUBE, L = 135	
12	153920001	1	クミヒモ4X4	WICK, 4X4 (L = 300)	
13	107149001	1	フェルト	FELT	
14	S21527001	1	テンピンキユウユササエ	WICK SUPPORT	
15	S10162201	1	ハリボウヒモササエ	WICK SUPPORT	
16	060670512	1	バインド357-40X5	SCREW, BIND SM3.57-40X5	
17	S37984000	1	ビニルチューブ	OIL TUBE, L = 290	
18	S41715001	1	クミヒモ4X4	WICK, 4X4 (L = 800)	
19	153562001	1	ヒラクミヒモ	FLAT WICK, L = 150	
20	151927001	1	クラツチフェルト	CLUTCH FELT	
21	104567001	1	クミヒモササエ	WICK SUPPORT	
23	S37985000	1	スイアゲフェルト	FELT	
24	S37986000	1	ビニルチューブ	OIL TUBE, L = 440	
25	S18093100	1	クミヒモ4X4	WICK, 4X4 (L = 1100)	
26	145547001	1	チューブホルダ	TUBE HOLDER	
27	062670512	1	ナベコ357-40X5	SCREW, PAN SM3.57-40X5	
28	S37987001	1	シタジクキユウユササエ	FELT SUPPORT	
29	S37988000	1	シタジクキユウユフェルト	FELT	
30	062680612	1	ナベコ4.37-40X6	SCREW, PAN SM4.37-40X6	
31	S09043000	1	フェルト	FELT	
32	152948001	1	オイルボツトマド	OIL WINDOW	
34	S34983000	1	ビニルチューブ	OIL TUBE, L = 160	
35	S34986000	1	ビニルチューブ	OIL TUBE, L = 135	
36	S34982000	1	ビニルチューブ	OIL TUBE, L = 70	
37	153920001	1	クミヒモ4X4	WICK, 4X4 (L = 300)	
38	152969001	1	コードササエカネ	CORD SUPPORT	
39	062670512	1	ナベコ357-40X5	SCREW, PAN SM3.57-40X5	
40	148738000	1	クミヒモ	WICK, L = 335	
41	148738000	1	クミヒモ	WICK, L = 335	
42	152956001	1	クミヒモ4X4	WICK, 4X4 (L = 500)	
44	228475000	3	ケツソクバンド1.9X80	FASTENING BAND, 1.9X80	
45	S37984000	1	ビニルチューブ	OIL TUBE, L = 290	
46	S41715001	1	クミヒモ4X4	WICK, 4X4 (L = 800)	
50	S41716000	1	クミヒモ	WICK, (L = 80)	
51	152962001	1	ハリボウメタルヒモササエ	WICK SUPPORT	
52	152960001	1	ヒラクミヒモ	FLAT WICK (L = 40)	

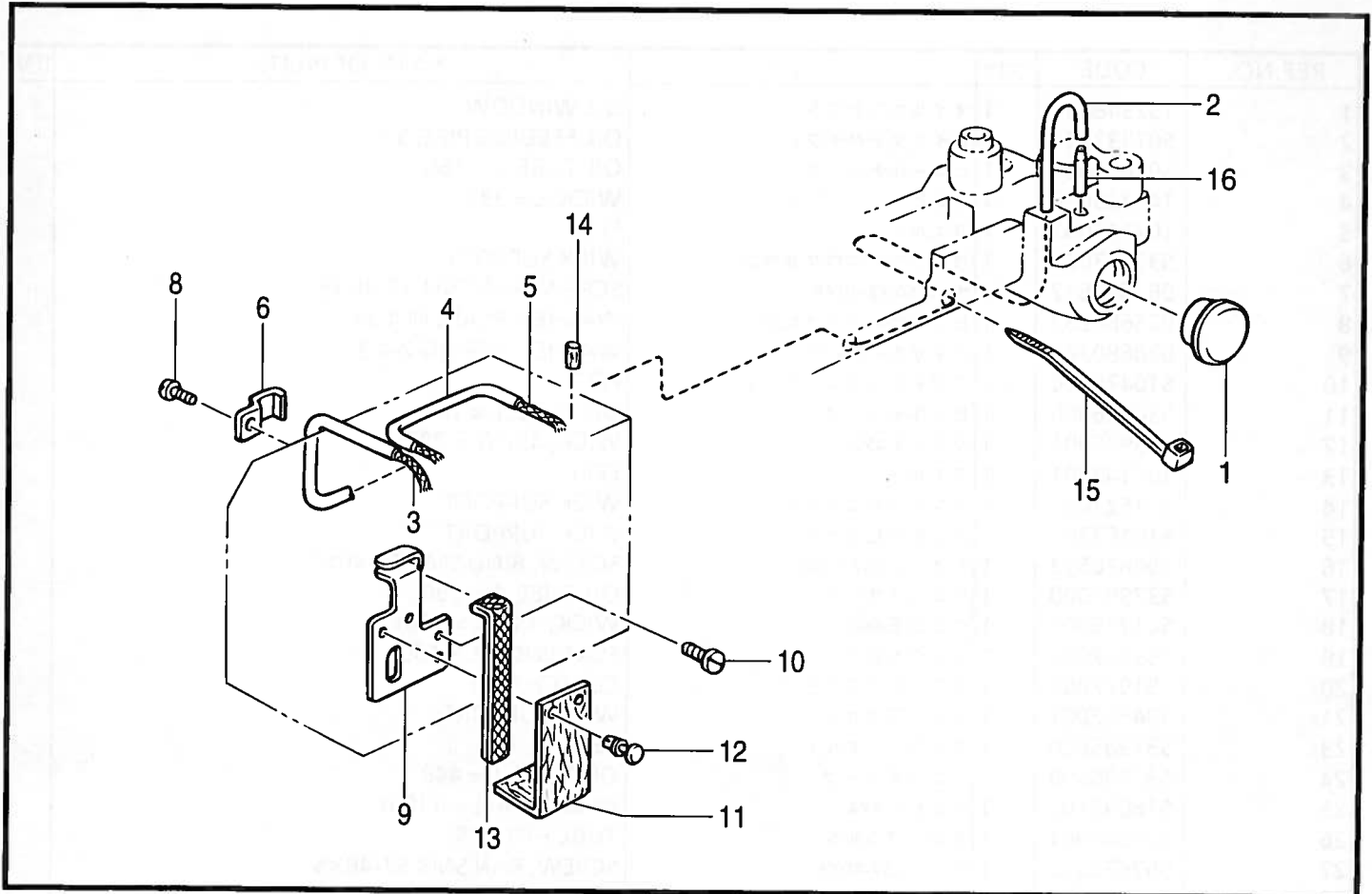

151-705-350

H . 糸払イ關係 / Thread wiper mechanism / Fadenwischvorrichtung / Mécanisme de tire-fil / Mecanismo del limpiador de hilo

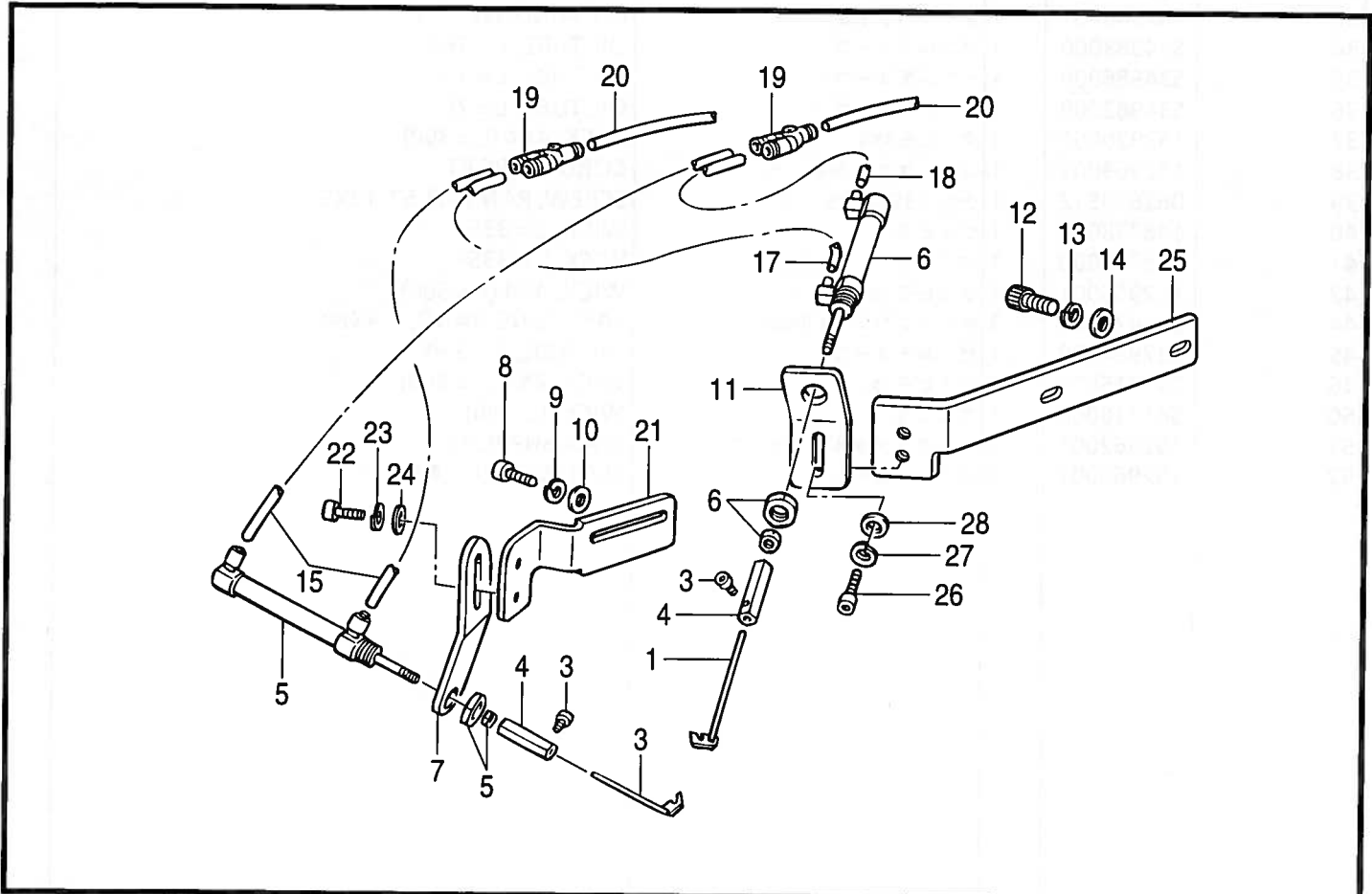

151-705-405

G2 . 給油潤滑関係 / Lubrication / Schmierung / Lubrification / Lubricación

REF.NO.	CODE	Q'TY	ヒンメイ	NAME OF PARTS	RM
1	152948001	1	オイルホツトマド	OIL WINDOW	
2	S41852000	1	ビニールチューブ	OIL TUBE, (L = 480)	
3	S41853001	1	クミヒモ4X4	WICK, 4X4 (L = 700)	
4	S34982000	1	ビニールチューブ	OIL TUBE, L = 70	
5	S41855001	1	クミヒモ4X4	WICK, 4X4 (L = 40)	
6	140647001	1	コードオサエ	CORD HOLDER	
8	062670512	1	ナベコ357-40X5	SCREW, PAN SM3.57-40X5	
9	S41856000	1	BMタイキユウユササエ	BM-BASE WICK SUPPORT	
10	106629002	2	シメネジ4.37	SCREW, SM4.37	
11	S41857001	1	BMトウシンササエフェルト	FELT, BM WICK SUPPORT	
12	S35001000	2	ナイロンリベット	NYLON RIVET	
13	153562001	1	ヒラクミヒモ	FLAT WICK, L = 150	
14	145624000	1	フェルト	FELT	
15	228475000	1	ケツソクバンド1.9X80	FASTENING BAND, 1.9X80	
16	S07333001	1	オイルクチパイプS	OIL FEEDING PIPE, S	

151-705-350

H . 糸払イ関係 / Thread wiper mechanism / Fadenwischvorrichtung / Mécanisme de tire-fil / Mecanismo del limpiador de hilo

REF.NO.	CODE	Q'TY	ヒンメイ	NAME OF PARTS	RM
1	S07553001	1	イトハライ	THREAD WIPER	
2	S41865001	1	イトハライF	THREAD WIPER, F	
3	S07424001	2	トメネジ3.18	BOLT, SOCKET SM3.18X4	
4	S41866001	2	イトハライウデ	THREAD WIPER ARM	
5	S41867000	1	シリンダクミ	CYLINDER ASSY	
6	S41581000	1	シリンダー10X30クミ	CYLINDER ASSY, 10X30	
7	S41870001	1	イトハライササエイタF	THREAD WIPER SUPPORT PLATE, F	
8	018401036	1	アナボルト4X10	BOLT, SOCKET M4X10	
9	028040246	1	バネザガネ2-4	WASHER, SPRING 2-4	
10	025040236	1	ヒラザガネチユウ4	WASHER, PLAIN M 4	
11	S41871001	1	イトハライササエイタR	THREAD WIPER SUPPORT PLATE, R	
12	018401036	2	アナボルト4X10	BOLT, SOCKET M4X10	
13	028040246	2	バネザガネ2-4	WASHER, SPRING 2-4	
14	025040236	2	ヒラザガネチユウ4	WASHER, PLAIN M 4	
15	S41936000	2	エアホース0425S044B	AIR TUBE, 0425S (L = 440)	
17	S41935000	1	エアホース0425S035B	AIR TUBE, 0425S (L = 350)	
18	S28741000	1	エアチューブ	AIR TUBE, L = 290	
19	S19557000	2	コガタユニオンワイ4	MINIATURE UNION, Y4	
20	S41943000	2	エアホース0425S145B	AIR TUBE, 0425S (L = 1450)	
21	S41872001	1	イトハライスライドイタF	THREAD WIPER SLIDE PLATE, F	
22	018400836	2	アナボルト4X8	BOLT, SOCKET M4X8	
23	028040246	2	バネザガネ2-4	WASHER, SPRING 2-4	
24	025040236	2	ヒラザガネチユウ4	WASHER, PLAIN M 4	
25	S41873001	1	イトハライスライドイタR	THREAD WIPER SLIDE PLATE, R	
26	018401236	2	アナボルト4X12	BOLT, SOCKET M4X12	
27	028040246	2	バネザガネ2-4	WASHER, SPRING 2-4	
28	025040236	2	ヒラザガネチユウ4	WASHER, PLAIN M 4	

151-705-405

J. 糸通シ関係 / Threading mechanism / Fadenführungsrichtung / Mécanisme de l'enfilage / Mecanismo del enhebrado

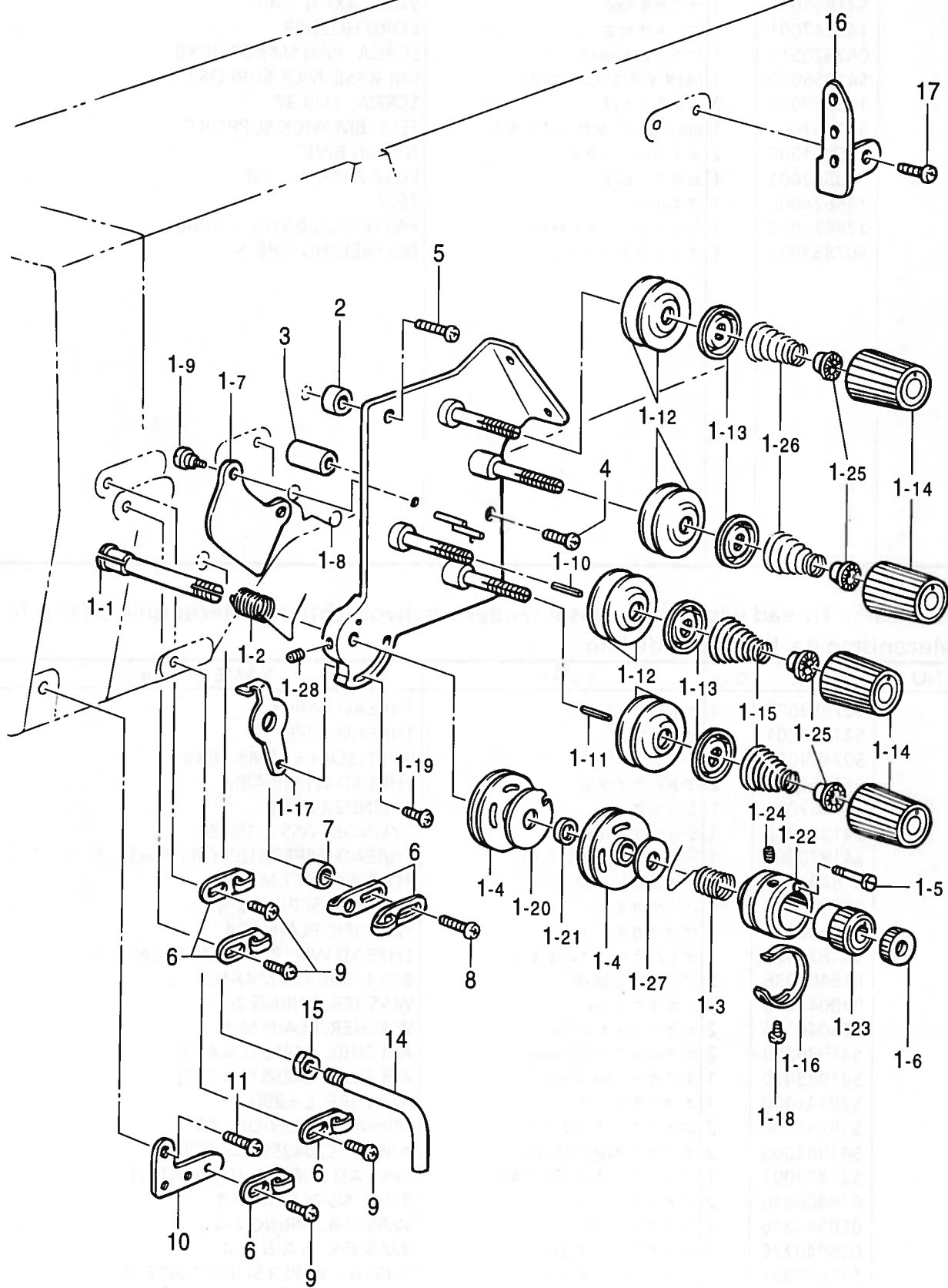

J. 糸通シ関係 / Threading mechanism / Fadenführungsrichtung / Mécanisme de l'enfilage / Mecanismo del enhebrado

REF.NO.	CODE	Q'TY	ヒンメイ	NAME OF PARTS	RM
1	S41719001	1	ウワイトチヨウシクミ	UPPER THREAD TENSION ASSY	
1-1	S41721001	1	チヨウシジク	THREAD TENSION STUD	
1-2	S41722001	1	イトトリバネL	TENSION SPRING, L	
1-3	S41723001	1	イトトリバネR	TENSION SPRING, R	
1-4	S41724001	2	イトトリバネアンナイクミ	TENSION SPRING GUIDE ASSY	
1-5	146124001	1	シメネジ2.38	SCREW, SM2.38	
1-6	108265009	1	イトチヨウシナツト	TENSION NUT	
1-7	S41725001	1	イトユルメイタ	TENSION RELEASE PLATE	
1-8	S38274001	1	イトユルメバネ	SPRING, TENSION RELEASE	
1-9	112712001	2	ダンネジ3.57	SHOULDER SCREW, SM3.57	
1-10	S07488001	1	イトユルメピンL	PIN, TENSION RELEASE (L)	
1-11	158769001	1	イトユルメピンR	PIN, TENSION RELEASE (R)	
1-12	145446001	8	イトチヨウシサラ	TENSION DISC	
1-13	159805001	4	イトチヨウシサラオサエ	TENSION DISC PRESSER	
1-14	149566109	4	イトチヨウシナツト	TENSION NUT	
1-15	148851001	2	ハリイトチヨウシバネ	THREAD TENSION ADJUST SPRING	
1-16	S41726001	1	イトトリバネストツバ	TENSION SPRING STOPPER	
1-17	S41727001	1	イトトリバネストツバL	TENSION SPRING STOPPER, L	
1-18	062670512	1	ナベコ357-40X5	SCREW, PAN SM3.57-40X5	
1-19	060350812	1	バインド35X8	SCREW, BIND M3.5X8	
1-20	S08605101	1	スヘーサー	SPACER	
1-21	S08606001	1	カラー	COLLAR	
1-22	S41728001	1	ストツハウケ	STOPPER SUPPORT	
1-23	S08610101	1	チヨウセツツマミ	ADJUST THUMB	
1-24	013660612	1	トメネジ3.18クボミ	SET SCREW, (CP) SM3.18	
1-25	144105000	4	チヨウシバネウエザガネ	FLANGE WASHER, TENSION SPRING	
1-26	144110001	2	シタルーハイトチヨウシバネ	THREAD TENSION ADJUST SPRING	
1-27	109893002	1	ザガネ	WASHER	
1-28	012400436	1	アナヒラ4X4	SET SCREW, SOCKET (FT) M4X4	
2	S03303001	1	カラー	COLLAR	
3	S07071001	1	オサエアゲコロ	PRESSER BAR LIFTER ROLLER	
4	062682012	1	ナベコ437-40X20	SCREW, PAN SM4.37-40X20	
5	062681212	1	ナベコ437-40X12	SCREW, PAN SM4.37-40X12	
6	S41729001	6	アームイトアンナイ	ARM THREAD GUIDE	
7	153215001	1	フォトダイカラー-21	COLLAR, 21	
8	062671412	1	ナベコ357-40X14	SCREW, PAN SM3.57-40X14	
9	060670612	4	バインド357-40X6	SCREW, BIND SM3.57-40X6	
10	S41730001	1	アームイトアンナイガイド	GUIDE, ARM THREAD GUIDE	
11	060670612	1	バインド357-40X6	SCREW, BIND SM3.57-40X6	
14	S41731001	1	アームイトカケ	ARM THREAD GUIDE	
15	021680202	1	ナツト2シユ4.37	NUT, 2 SM4.37	
16	152889001	1	ミツメイトカケ	THREAD RETAINER	
17	062670612	2	ナベコ357-40X6	SCREW, PAN SM3.57-40X6	

K. 糸巻関係 / Bobbin winder mechanism / Spuler / Mécanisme du bobineur
 / Mecanismo del devanador de la canilla

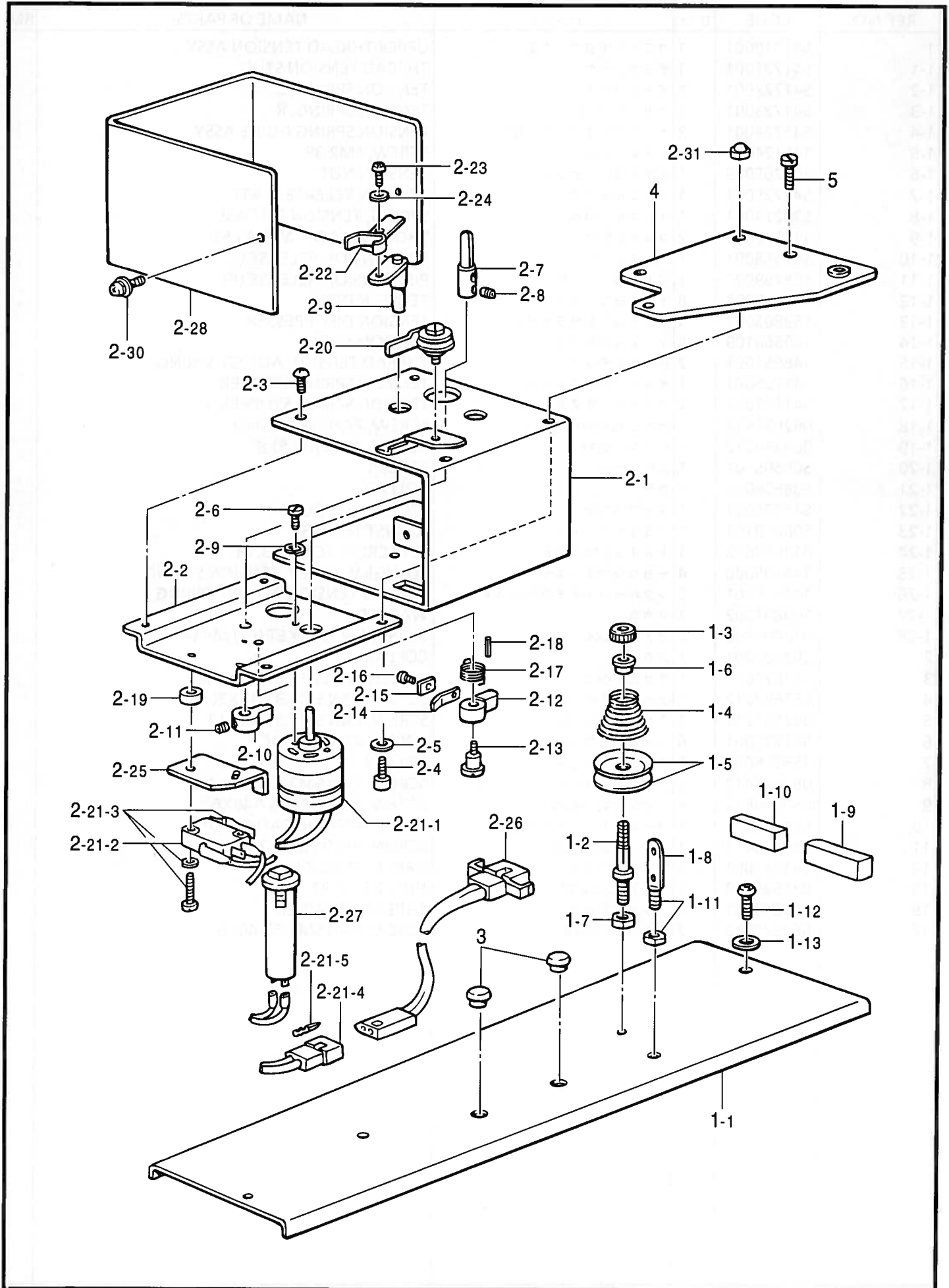

K. 糸巻関係 / Bobbin winder mechanism / Spuler / Mécanisme du bobineur
/ Mecanismo del devanador de la canilla

REF.NO.	CODE	Q'TY	ヒンメイ	NAME OF PARTS	RM
1	S41859009	1	ウワブタクミ	TOP COVER ASSY	
1-1	S41860009	1	ウワブタ	TOP COVER	
1-2	159574101	1	イトチヨウシボウ	TENSION STUD	
1-3	100136001	1	イトチヨウシナツト	TENSION NUT	
1-4	144110001	1	シタルーハイトチヨウシバネ	THREAD TENSION ADJUST SPRING	
1-5	145446001	2	イトチヨウシサラ	TENSION DISC	
1-6	144105000	1	チヨウシバネウエザガネ	FLANGE WASHER, TENSION SPRING	
1-7	021680202	1	ナツト2シユ4.37	NUT, 2 SM4.37	
1-8	141590001	1	イトトオシボウ	THREADING BAR, U	
1-9	S41861000	1	クツシヨソL	CUSHION, L	
1-10	S41862000	1	クツシヨソS	CUSHION, S	
1-11	100022004	2	ナツト5.95	NUT, SM5.95	
1-12	062681212	3	ナベコ437-40X12	SCREW, PAN SM4.37-40X12	
1-13	025680232	3	ヒラザガネチユウ4.37	WASHER, PLAIN M 4.37	
2	S41863009	1	イトマキソウチクミ	BOBBIN WINDER ASSY	
2-1	S41858009	1	イトマキベース	BOBBIN WINDER BASE	
2-2	S41851001	1	イトマキモータシジイタ	B-WINDER MOTOR SUPPORT PLATE	
2-3	008300604	2	+トラスコ3X6	SCREW, TRUSS M3X6	
2-4	018401236	2	アナボルト4X12	BOLT, SOCKET M4X12	
2-5	110735002	2	ザガネ	WASHER	
2-6	S35032101	2	シメネジ2.6X5.5	SCREW, M2.6X5.5	
2-7	S39903001	1	イトマキジク	BOBBIN WINDER SHAFT	
2-8	014300332	2	アナクボミ3X3	SET SCREW, SOCKET (CP) M3X3	
2-9	154024001	1	ボビンオサエ	BOBBIN PRESSER	
2-10	154092001	1	イトマキツメダンツキ	BOBBIN WINDER CLAW	
2-11	014680422	2	アナトメネジ4.37クボミ	SET SCREW, SOCKET (CP) SM4.37	
2-12	152361001	1	イトマキレバー	BOBBIN WINDER LEVER	
2-13	152362001	1	イトマキダンネジ	BOBBIN WINDER SHOULDER SCREW	
2-14	111942001	1	イタバネ	SPRING, PLATE	
2-15	111943001	1	イタバネザガネ	WASHER	
2-16	060660512	1	バインド318-40X5	SCREW, BIND SM3.18-40X5	
2-17	152363001	1	ネジリバネA	SPRING, TWIST A	
2-18	047301042	1	スプリングピン	PIN, SPRING ROLL AW3	
2-19	152364001	2	カラー	COLLAR	
2-20	146197001	1	イトツカミクミ	THREAD CLAMP ASSY	
2-21	S39847001	1	イトマキモータクミ	BOBBIN WINDER MOTOR ASSY	
2-21-1	S39908000	1	イトマキモータ	BOBBIN WINDER MOTOR	
2-21-2	152507000	1	マイクロスイッチD	MICRO SWITCH, D	
2-21-3	152508000	1	マイクロアクチュエータ	MICRO ACTUATOR	
2-21-4	152509000	1	ナイロンコネクタE	NYLON CONNECTOR, E	
2-21-5	552851001	2	ヒンターミナル#1854	TERMINAL PIN, #1854	
2-22	152645001	1	ボビンオサエイタ	BOBBIN HOLDER PLATE	
2-23	062300616	1	ナベコM3X6	SCREW, PAN M3X6	
2-24	025030236	1	ヒラザガネチユウ3	WASHER, PLAIN M 3	
2-25	158597001	1	イトマキストツハー	BOBBIN WINDER STOPPER	
2-26	S21103000	1	イトマキハーネスC	BOBBIN WINDER HARNESS, C	
2-27	S16669000	1	プロテクタ0.5A	PROTECTOR, 0.5A	
2-28	S31960009	1	イトマキカバー	BOBBIN WINDER COVER	
2-29	028260242	2	バネザガネ2-2.6	WASHER, SPRING 2-2.6	
2-30	052300606	2	ナベコバネヒラ3X6	SCREW, PAN (S/P WASHER) M3X6	
2-31	S00505001	2	ロツカクフクロナツトM4	NUT, CAP M4	
3	104450109	2	ゴムセン8	RUBBER CAP, 8	
4	S41864009	1	イトマキソウチトリツケイタ	SETTING PLATE, BOBBIN WINDER	
5	106629002	2	シメネジ4.37	SCREW, SM4.37	

L. 糸切り関係 / Thread trimmer mechanism / Fadenabschneidevorrichtung
 / Mécanisme de coupe-fil / Mecanismo de la cortadura de hiros

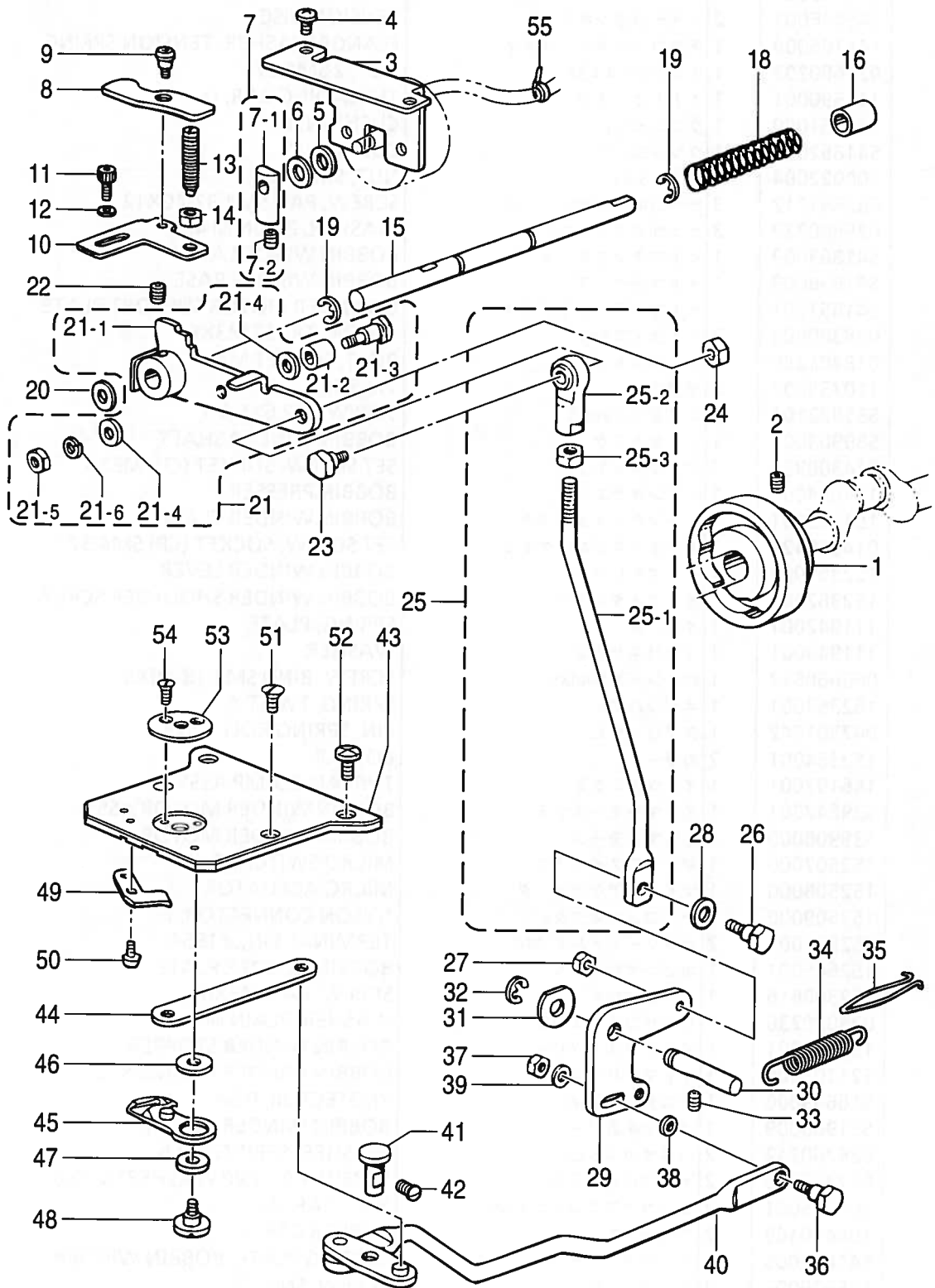

L. 糸切り関係 / Thread trimmer mechanism / Fadenabschneidevorrichtung
/ Mécanisme de coupe-fil / Mecanismo de la cortadura de hiros

REF.NO.	CODE	Q'TY	ヒンメイ	NAME OF PARTS	RM
1	S38001001	1	イトキリカム	THREAD TRIMMER CAM	
2	014770622	2	アナトメネジ6.35クボミ	SET SCREW, SOCKET (CP) SM6.35	
3	S38002101	1	ソレノイドトリツケイタ	SOLENOID SETTING PLATE	
4	060680712	2	バインド437-40X7	SCREW, BIND SM4.37-40X7	
5	154599000	1	ソレノイドクツシヨン	SOLENOID CUSHION	
6	S02652001	1	ザガネ	WASHER	
7	S23836001	1	ソレノイドレバークミ	SOLENOID LEVER ASSY	
7-1	S02654001	1	ソレノイドレバー	SOLENOID LEVER	
7-2	014680622	1	アナトメネジ4.37クボミ	SET SCREW, SOCKET (CP) SM4.37	
8	S38003001	1	クドウレバーオシレバー	PUSHING LEVER DRIVING LEVER	
9	145478101	1	ダンネジ4.76	SHOULDER SCREW, SM4.76	
10	S38004002	1	クドウレバーストツハ <記号2>	DRIVING LEVER STOPPER, H = 0.3 .. <Mark2>	
10	S38004003	1	クドウレバーストツハ <記号3>	DRIVING LEVER STOPPER, H = 0.6 .. <Mark3>	
10	S38004004	1	クドウレバーストツハ <記号4>	DRIVING LEVER STOPPER, H = 0.45 <Mark4>	
11	018681022	2	アナボルト4.37X10	BOLT, SOCKET SM4.37X10	
12	025680132	2	ヒラザガネシヨウ4.37	WASHER, PLAIN S 4.37	
13	159905001	1	トメヌイチヨウセツネジ	ADJUST SCREW	
14	106147002	1	ナツト7.94	NUT, SM7.94	
15	S38005001	1	クドウレバーアンナイジク	DRIVING LEVER SHAFT	
16	231071001	1	メタル8X15	BUSH, 8X15	
18	S41734001	1	クドウジクモドシバネ	RETURN SPRING, DRIVING SHAFT	
19	048070342	2	トメワE7	RETAINING RING, E7	
20	154596000	1	イトキリカムレバークツシヨン	CUSHION	
21	S38006001	1	イトキリクドウレバークミ	TR. TRIMMER DRIVING LEVER ASSY	
21-1	S38007001	1	イトキリクドウレバー	THREAD TRIMMER DRIVING LEVER	
21-2	153597001	1	シタイトサバキカラー	LOWER THREAD RETAINER COLLAR	
21-3	S30033001	1	ダンネジ3.57	SHOULDER SCREW, SM3.57	
21-4	148813001	2	ザガネ	WASHER	
21-5	106129002	1	ナツト3.57	NUT, SM3.57	
21-6	028350242	1	バネザガネ2-3.5	WASHER, SPRING 2-3.5	
22	014770622	1	アナトメネジ6.35クボミ	SET SCREW, SOCKET (CP) SM6.35	
23	S02354001	1	タマツギテダンネジB	SHOULDER SCREW, B	
24	100022005	1	ナツト5.95	NUT, SM5.95	
25	S38008001	1	イトキリロツドクミ	THREAD TRIMMER ROD ASSY	
25-1	S38009001	1	イトキリロツド	THREAD TRIMMER ROD	
25-2	S07512001	1	タマツギテRクミ	ROUND JOINT ASSY, R	
25-3	100022005	1	ナツト5.95	NUT, SM5.95	
26	110233001	1	ダンネジ4.76	SHOULDER SCREW, SM4.76	
27	110161004	1	ナツト4.76	NUT, SM4.76	
28	109893002	1	ザガネ	WASHER	
29	S38010001	1	イトキリレバー	THREAD TRIMMER LEVER	
30	S10195001	1	イトキリレバークミ	LEVER SHAFT	
31	110367001	1	ザガネ	WASHER, PLAIN SPECIAL 8	
32	048060342	1	トメワE6	RETAINING RING, E6	
33	014760622	1	アナトメネジ5.95	SET SCREW, SOCKET SM5.95	
34	S38011001	1	イトキリモドシバネ	THREAD TRIMMER RETURN SPRING	
35	158940001	1	バネカケ	SPRING HOOK	
36	110233001	1	ダンネジ4.76	SHOULDER SCREW, SM4.76	
37	110161004	1	ナツト4.76	NUT, SM4.76	
38	153484001	1	ザガネ4.76	WASHER, PLAIN 4.76	
39	025680232	1	ヒラザガネチヨウ4.37	WASHER, PLAIN M 4.37	
40	S41735001	1	レンカンレバークミ	CONNECTIG ROD LEVER ASSY	
41	S10202101	1	レンカンレバークミ	CONNECTING ROD LEVER SHAFT	
42	121007001	1	アタマツキトメネジ4.37	SET SCREW, SM4.37	
43	S41737001	1	ハリイタ	NEEDLE PLATE	
44	S38016001	1	イトキリレンカン	THREAD TRIMMER CONNECTING ROD	
45	S10205001	1	イドウハクミ	MOVABLE KNIFE ASSY	
46	S10208001	1	イドウハカンザ <t=0.4>	WASHER, MOVABLE KNIFE T = 0.4 <t=0.4>	
46	S10208002	1	イドウハカンザ <t=0.5>	WASHER, MOVABLE KNIFE T = 0.5 <t=0.5>	

L. 糸切り関係 / Thread trimmer mechanism / Fadenabschneidevorrichtung
 / Mécanisme de coupe-fil / Mecanismo de la cortadura de hiros

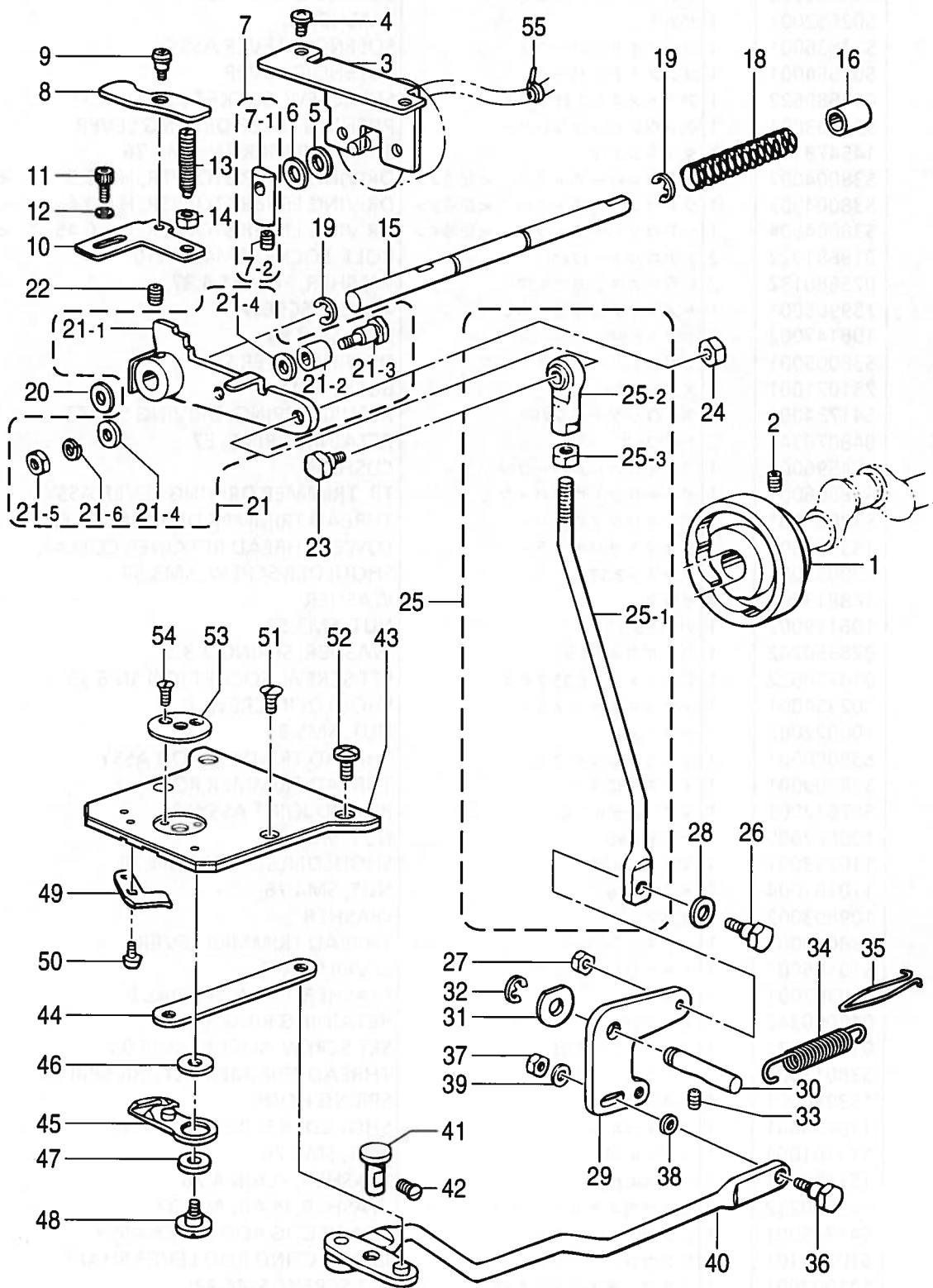

L. 糸切り関係 / Thread trimmer mechanism / Fadenabschneidevorrichtung
 / Mécanisme de coupe-fil / Mecanismo de la cortadura de hiros

REF.NO.	CODE	Q'TY	ヒンメイ	NAME OF PARTS	RM
46	S10208003	1	イドウハカンザ <t=0.6>	WASHER, MOVABLE KNIFE T = 0.6 <t = 0.6>	
47	S00705001	1	イドウハカラー	MOVABLE KNIFE COLLAR	
48	S10209101	1	シメネジ4.37	SCREW, SM4.37	
49	S41738001	1	コテイハ	FIXED KNIFE	
50	111140002	2	シメネジ2.38	SCREW, SM2.38	
51	100032004	2	サラネジ4.37	SCREW, FLAT SM4.37	
52	S11244001	2	シメネジ4.37	SCREW, SM4.37	
53	S10212101	1	ハリアナイタE	NEEDLE HOLE PLATE, E	
54	100360003	2	サラネジ2.38	SCREW, FLAT SM2.38	
55	228475000	1	ケツソクバンド 1.9X80	FASTENING BAND, 1.9X80	

M. 糸締メ関係 / Thread nipper mechanism / Fadenspannvorrichtung / Mécanisme de pince-fil / Mecanismo de la mordaza para hilo

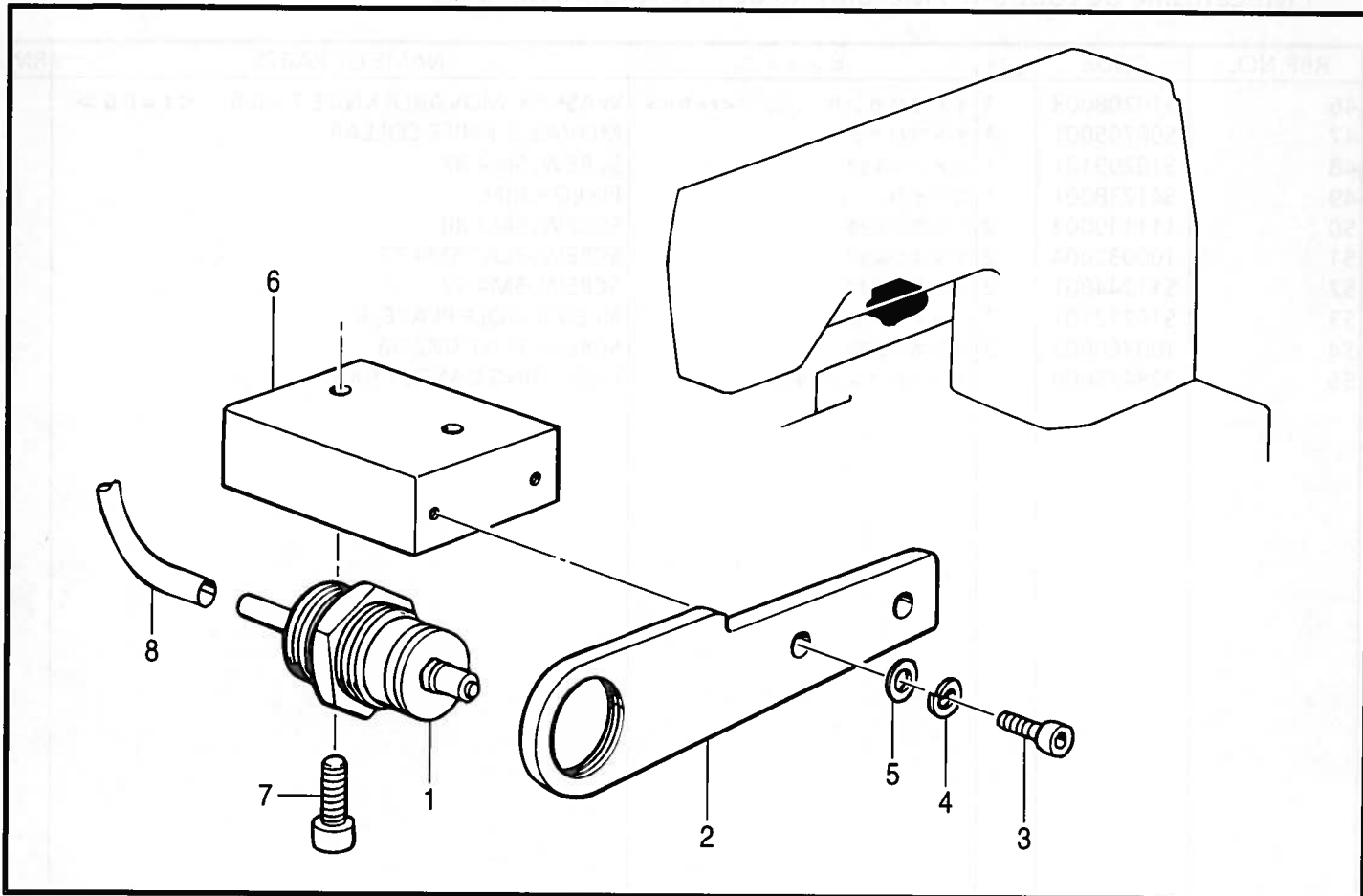

151-705-406

N. 針位置検出器関係 / Synchronizer / Synchronisator / Synchronisateur / Sincronizador

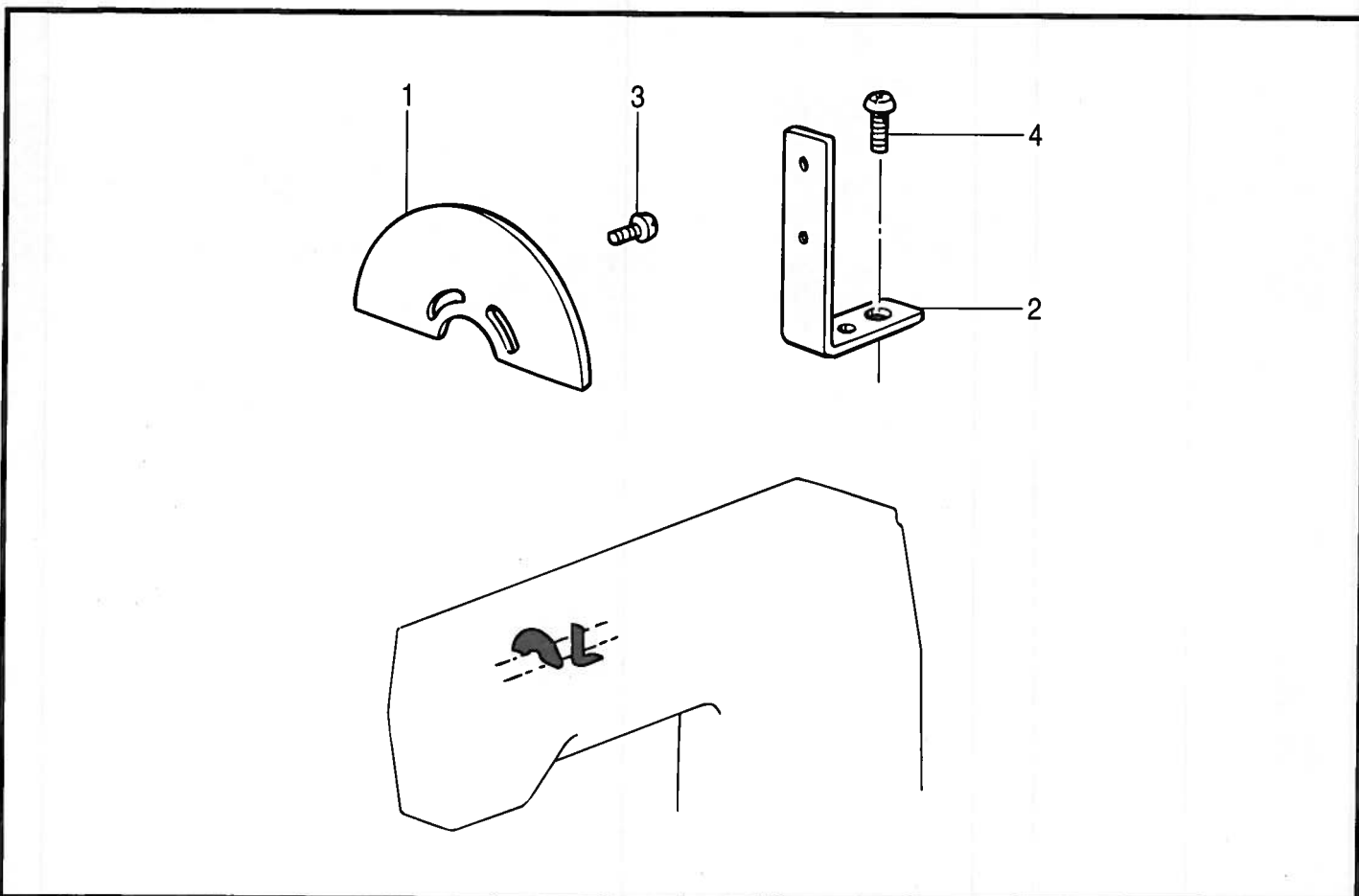

118-705-501

M. 糸締メ関係 / Thread nipper mechanism / Fadenspannvorrichtung / Mécanisme de pince-fil / Mecanismo de la mordaza para hilo

REF.NO.	CODE	Q'TY	ヒンメイ	NAME OF PARTS	RM
1	S41874000	1	シリンダクミ	CYLINDER ASSY	
2	S41877001	1	イトユルメシリンダイタ	THREAD RELEASE CYLINDER PLATE	
3	018501436	2	アナボルト5X14	BOLT, SOCKET M5X14	
4	028050246	2	バネザガネ2-5	WASHER, SPRING 2-5	
5	025050236	2	ヒラザガネチユウ5	WASHER, PLAIN M 5	
6	S41878001	1	イトユルメダイ	THREAD RELEASE BASE	
7	018501636	2	アナボルト5X16	BOLT, SOCKET M5X16	
8	S11440004	1	エアチューブ	AIR TUBE, 4 (L = 1750)	

151-705-406

N. 針位置検出器関係 / Synchronizer / Synchronisator / Synchronisateur / Sincronizador

REF.NO.	CODE	Q'TY	ヒンメイ	NAME OF PARTS	RM
1	S41741000	1	ホウコウセンサイタ	DIRCTION SENSOR PLATE	
2	S41742000	1	ウワジクセンサイタ	UPPER SHAFT SENSOR PLATE	
3	062300512	2	ナベコ3X5	SCREW, PAN M3X5	
4	062680812	1	ナベコ437-40X8	SCREW, PAN SM4.37-40X8	

118-705-501

P. コントロールボックス関係 / Control box mechanism / Schaltkasten
 / Mécanisme du boîtier de contrôle / Mecanismo de la caja de controles

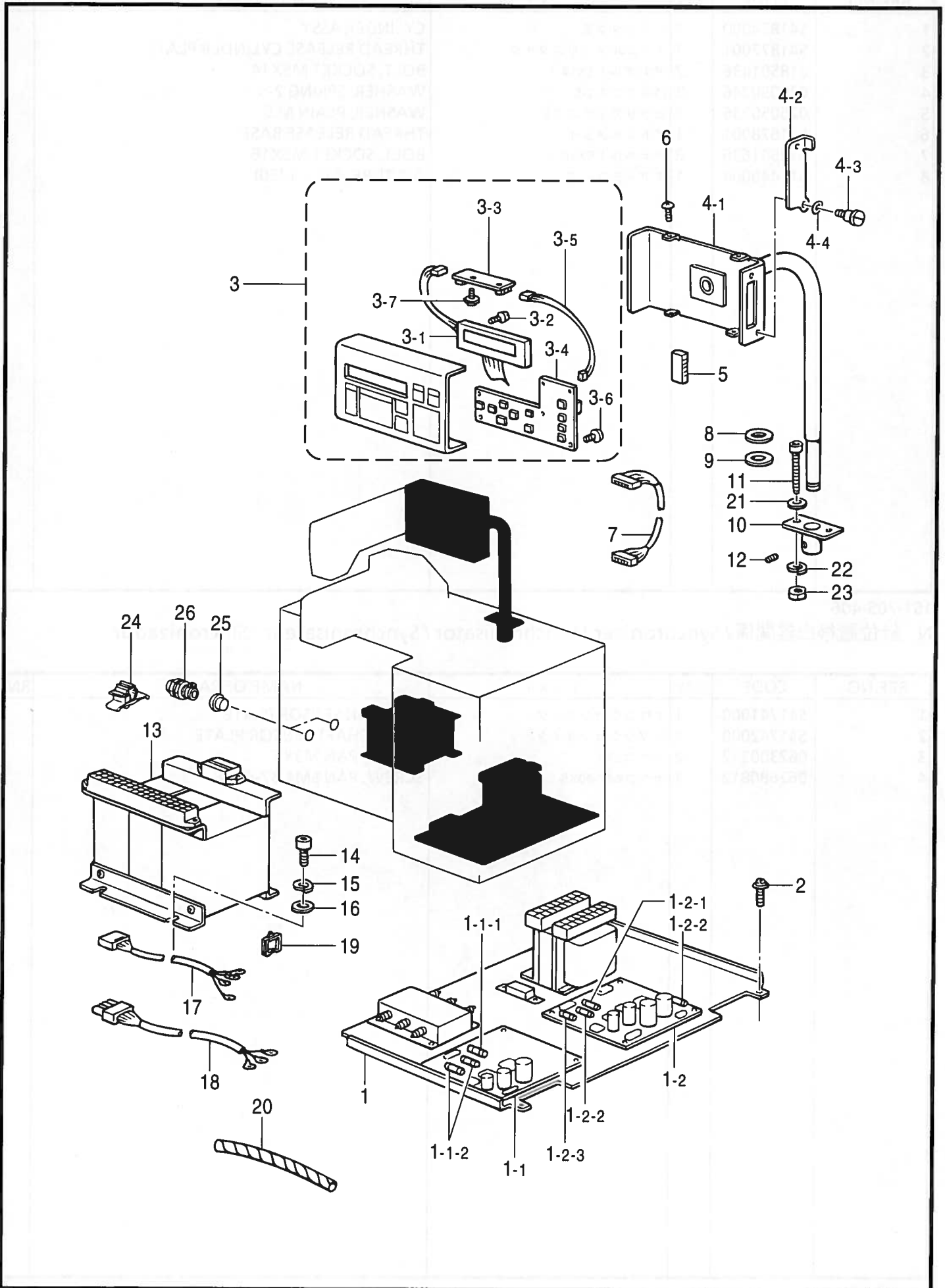

P. コントロールボックス関係 / Control box mechanism / Schaltkasten
/ Mécanisme du boîtier de contrôle / Mecanismo de la caja de controles

REF.NO.	CODE	Q'TY	ヒンメイ	NAME OF PARTS	RM
1	S40438001	1	デンゲンユニットクミ	POWER SUPPLY UNIT ASSY	
1-1	S40439001	1	デンゲンキバンAクミ	POWER CIRCUIT BOARD ASSY, A	
1-1-1	215769001	1	カンヒューズ3A	FUSE, 3A	
1-1-2	152566000	2	ヒューズC	FUSE, C 2A	
1-2	S40440001	1	デンゲンキバンBクミ	POWER CIRCUIT BOARD ASSY, B	
1-2-1	153242000	1	ヒューズ6A	FUSE, 6A	
1-2-2	157219000	2	カンヒューズ5A-D	FUSE, 5A	
1-2-3	152566000	1	ヒューズC	FUSE, C 2A	
2	0A5400806	4	+ナベザクミ4X8DB	SCREW, PAN (S/P WASHER) M4X8	
3	S40445009	1	ソウサハコフタクミ	CONTROL BOX COVER ASSY	
3-1	S40447000	1	LCDモジュール	LCD MODULE	
3-2	S46833001	4	ナベネジM1.6X4	SCREW, PAN M1.6	
3-3	S40448000	1	インバータ	INVERTER	
3-4	S40511001	1	ハネルキバンクミ	PANEL PCB ASSY	
3-5	S40455000	1	ハネルインバータハーネス	INVERTER HARNESS, PANEL	
3-6	0A5300605	6	+ナベザクミ3X6DB	SCREW, PAN (S/P WASHER) M3X6	
3-7	0A5301005	3	+ナベザクミ3X10DB	SCREW, PAN (S/P WASHER) M3X10	
4	S40451009	1	ソウサハコスタンドクミ	STAND ASSY, OPERATION BOX	
4-1	S40452009	1	ソウサハコスタンド	STAND, OPERATION BOX	
4-2	S40499009	1	ハネルヨコカバー	SIDE COVER, PANEL	
4-3	107321003	1	ダンネジ4.76	SHOULDER SCREW, SM4.76	
4-4	107017002	1	ナミバネザガネ	WASHER, WAVE SPRING 6.45	
5	S40453000	1	<日本語、英語> PROM705ハネルJクミ	<For Japanese & English version> PROM ASSY, 705 PANEL	
6	008400604	4	+トラスコ4X6	SCREW, TRUSS M4X6	
7	S40454000	1	ハネルハーネス	PANEL HARNESS	
8	S10409002	1	ザガネ	WASHER	
9	S10408000	1	ゴムシート	RUBBER SHEET	
10	S15056001	1	ハコササエホルダ	BOX HOLDER	
11	018065036	2	アナボルト6X50	BOLT, SOCKET M6X50	
12	014760622	1	アナトメネジ5.95	SET SCREW, SOCKET SM5.95	
13	S40504000	1	<三相380V, 400V, 415V用> 3ソウトランス705	<For 3-phase "380V, 400V & 415V"> TRANSFORMER, THREE PHASE 705	
14	018081236	4	アナボルト8X12	BOLT, SOCKET M8X12	
15	028080246	4	バネザガネ2-8	WASHER, SPRING 2-8	
16	025080236	4	ヒラザガネチユウ8	WASHER, PLAIN M 8	
17	S40505000	1	デンゲンハーネスHA	POWER SUPPLY HARNESS, HA	
18	S41969000	1	デンゲンハーネスHB	POWER SUPPLY HARNESS, HB	
19	S41964000	1	ブツシュ	BUSH	
20	S11763000	1	スバイラル100S	SPIRAL, 100S	
24	150357001	2	コードクランプ13	CORD CLAMP, 13-L	
26	152510000	2	コードブツシュ	CORD BUSH	
21	025060336	2	ヒラザガネダイ6	WASHER, PLAIN L 6	
22	028060246	2	バネザガネ2-6	WASHER, SPRING 2-6	
23	021060206	2	2シユナツト6	NUT, 2 M6	
25	140392009	2	オイルフタ	OIL CAP	
5	S45730000	1	" オプション部品 " <英語、ポルトガル語> PROM705ハネルPクミ	" OPTION PARTS " <For English & Portuguese version> PROM ASSY, P 705 PANEL	
5	S45731000	1	<英語、トルコ語> PROM705ハネルTクミ	<For English & Turkish version> PROM ASSY, T 705 PANEL	
5	S45732000	1	<英語、スペイン語> PROM705ハネルSクミ	<For English & Spanish version> PROM ASSY, S 705 PANEL	
5	S45733000	1	<英語、フランス語> PROM705ハネルFクミ	<For English & French version> PROM ASSY, F 705 PANEL	

Q. 空圧関係 / Air pressure mechanism / Luftdruck / Mécanisme de la pression d'air / Mecanismo de la presión de aire

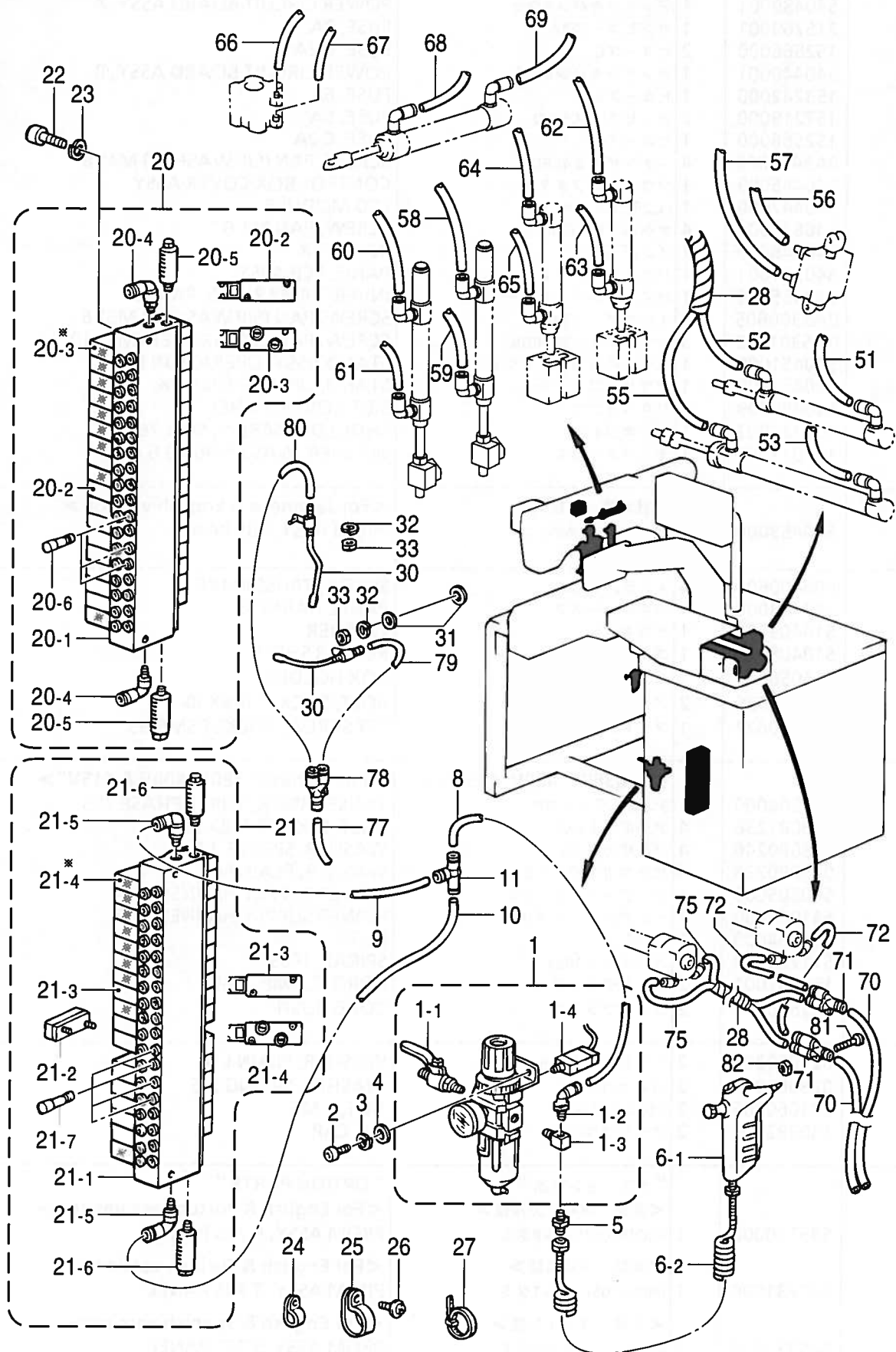

Q. 空圧関係 / Air pressure mechanism / Luftdruck / Mécanisme de la pression d'air
/ Mecanismo de la presión de aire

REF.NO.	CODE	Q'TY	ヒンメイ	NAME OF PARTS	RM
1	S41641000	1	フィルターレギュレータクミ	FILTER REGULATOR ASSY	
1-1	S09231000	1	ボールバルブ1/4	BALL VALVE, 1/4	
1-2	S31169000	1	エルボユニオン8	ELBOW UNION, 8	
1-3	153252000	1	PTチーズ	PT-JOINT	
1-4	S17028000	1	アツリヨクスイッチ	PRESSURE SWITCH	
2	018061222	2	アナボルト6X12	BOLT, SOCKET M6X12	
3	028060242	2	バネザガネ2-6	WASHER, SPRING 2-6	
4	025060232	2	ヒラザガネチユウ6	WASHER, PLAIN M 6	
5	S04891000	1	チユウカンニツブル1/4	MIDDLE NIPPLE, 1/4	
6	S06857000	1	エアガンクミ	AIR GUN ASSY	
6-1	S06858000	1	エアガン	AIR GUN	
6-2	S06859000	1	カールホース	CURL TUBE	
8	S31764000	1	エアチューブ8X280	AIR TUBE, 8 (L = 280)	
9	S39113000	1	エアホース0806S030B	AIR TUBE, 0806S (L = 300)	
10	S41637000	1	エアホース0806S024B	AIR TUBE, 0806S (L = 240)	
11	S31170000	1	チーズ8	T-JOINT, 8	

20	S41632000	1	<ベルトスラック装置用> バルブユニット18クミ	<For Belt feed device> VALVE UNIT ASSY, 18	
20-1	S41633000	1	マニホールド18	MANIFOLD, 18	
20-2	S39115000	9	バルブVQZ1151-5	VALVE, VQZ1151-5	
20-3	S39116000	9	バルブVQZ1151S-5	VALVE, VQZ1151S-5	
20-4	S14159000	2	エルボ1/8-8	ELBOW, 1/8-8	
20-5	140682001	2	サイレンサン	SILENCER	
20-6	S04897000	3	プラグ4	PLUG, 4	

21	S41631000	1	バルブユニット17クミ	VALVE UNIT ASSY, 17	
21-1	S41633000	1	マニホールド18	MANIFOLD, 18	
21-2	S41634000	1	ブランキングプレート	BLANKING PLATE	
21-3	S39115000	8	バルブVQZ1151-5	VALVE, VQZ1151-5	
21-4	S39116000	9	バルブVQZ1151S-5	VALVE, VQZ1151S-5	
21-5	S14159000	2	エルボ1/8-8	ELBOW, 1/8-8	
21-6	140682001	2	サイレンサン	SILENCER	
21-7	S04897000	4	プラグ4	PLUG, 4	
22	018503036	2	アナボルト5X30	BOLT, SOCKET M5X30	
23	028050246	2	バネザガネ2-5	WASHER, SPRING 2-5	
25	554482000	1	コードホルダ#12	CORD HOLDER, 12N	
26	0A5401006	1	ナベコバネヒラ4X10	SCREW, PAN (S/P WASHER) M4X10	
27	S04557000	20	ハンタイPLTIM	BAND, PLTIM	
28	S11763000	2	スライラル100S	SPIRAL, 100S	
30	S23747001	2	エアーブロークミ	AIR BLOWER ASSY	
31	025050236	2	ヒラザガネチユウ5	WASHER, PLAIN M 5	
32	028050246	2	バネザガネ2-5	WASHER, SPRING 2-5	
33	021500106	2	1シユナツ5	NUT, 1 M5	
51	S41938000	1	エアホース0425S105B	AIR TUBE, 0425S (L = 1050)	
52	S41938000	1	エアホース0425S105B	AIR TUBE, 0425S (L = 1050)	
53	S41939000	1	エアホース0425S112B	AIR TUBE, 0425S (L = 1120)	
55	S41636000	1	エアホース0425S100B	AIR TUBE, 0425S (L = 1000)	
56	S08176000	1	エアーホース4-O	AIR TUBE, 4-O (L = 980)	
57	S08176000	1	エアーホース4-O	AIR TUBE, 4-O (L = 980)	
58	S41943000	1	エアホース0425S145B	AIR TUBE, 0425S (L = 1450)	
59	S31706000	1	エアーチューブ4X1510	AIR TUBE, 4X1510	
60	S41943000	1	エアホース0425S145B	AIR TUBE, 0425S (L = 1450)	
61	S31706000	1	エアーチューブ4X1510	AIR TUBE, 4X1510	
62	S41941000	1	エアホース0425S137B	AIR TUBE, 0425S (L = 1370)	
63	S41943000	1	エアホース0425S145B	AIR TUBE, 0425S (L = 1450)	
64	S41941000	1	エアホース0425S137B	AIR TUBE, 0425S (L = 1370)	

Q . 空圧関係 / Air pressure mechanism / Luftdruck / Mécanisme de la pression d'air
 / Mecanismo de la presión de aire

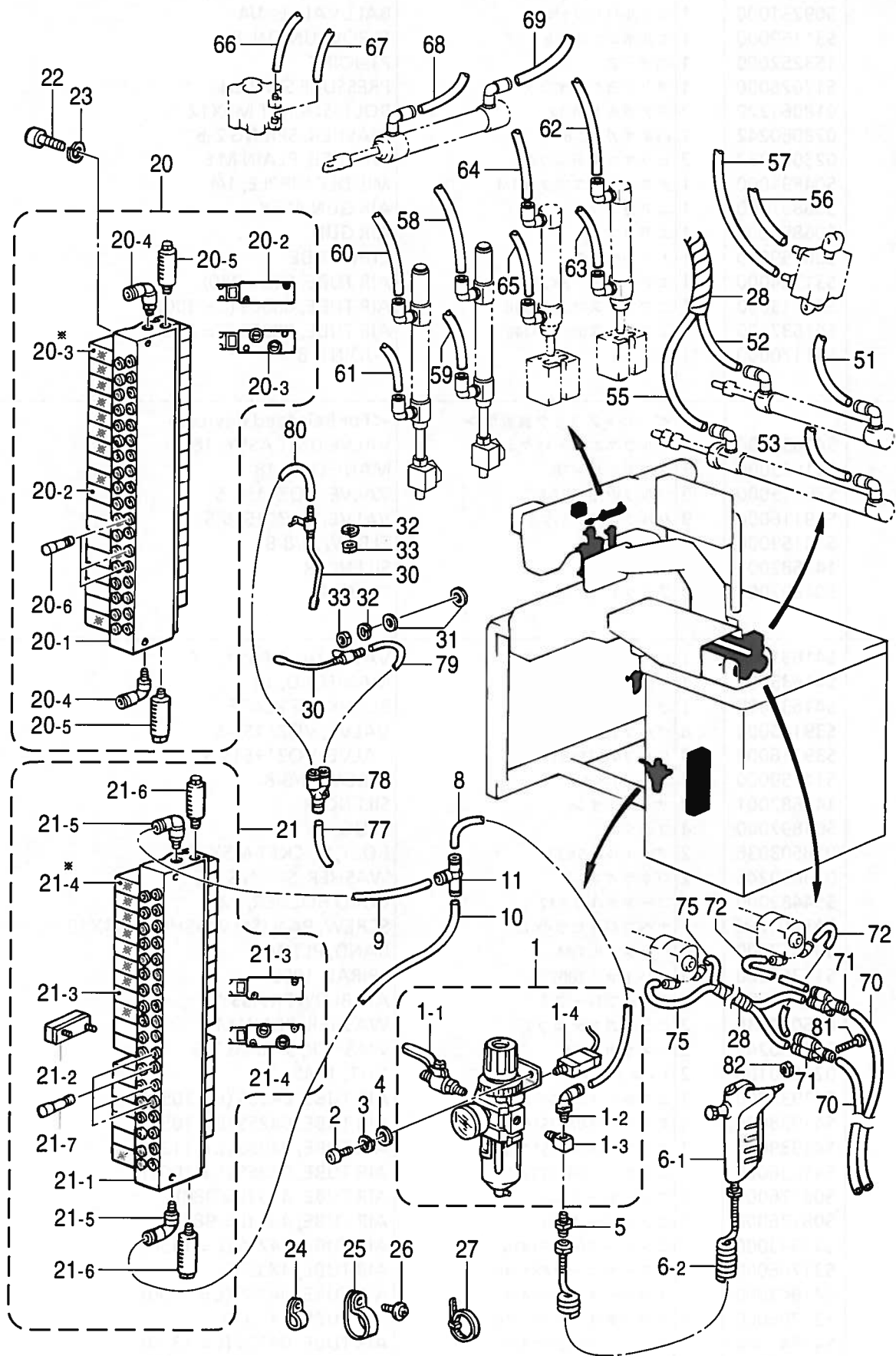

Q. 空圧関係 / Air pressure mechanism / Luftdruck / Mécanisme de la pression d'air
/ Mecanismo de la presión de aire

REF.NO.	CODE	Q'TY	ヒンメイ	NAME OF PARTS	RM
65	S31706000	1	エアータブ 4X1510	AIR TUBE, 4X1510	
66	S41940000	1	エアホース 0425S124B	AIR TUBE, 0425S (L = 1240)	
67	S41940000	1	エアホース 0425S124B	AIR TUBE, 0425S (L = 1240)	
68	S41938000	1	エアホース 0425S105B	AIR TUBE, 0425S (L = 1050)	
69	S41939000	1	エアホース 0425S112B	AIR TUBE, 0425S (L = 1120)	
70	S14085008	2	エアータブ	AIR TUBE, 4X1160	
71	S19557000	2	コガタユニオンワイ 4	MINIATURE UNION, Y4	
72	S41916000	2	エアホース 0425S022B	AIR TUBE, 4 (L = 220)	
75	S15031002	2	エアータブ	AIR TUBE, (L = 240)	
77	S33870001	1	エアータブ	AIR TUBE, 4 (L = 840) BLACK	
78	S19557000	1	コガタユニオンワイ 4	MINIATURE UNION, Y4	
79	S41935000	1	エアホース 0425S035B	AIR TUBE, 0425S (L = 350)	
80	S41937000	1	エアホース 0425S060B	AIR TUBE, 0425S (L = 600)	
81	062302506	1	ナベコ 3X25	SCREW, PAN M3X25	
82	021300206	1	2シユナツ 3	NUT, 2 M3	

R1 . 電装品関係 / Power supply equipment mechanism / Stromversorgung
 / Mécanisme de l'équipement en alimentation électrique
 / Mecanismo del equipo de alimentación de corriente

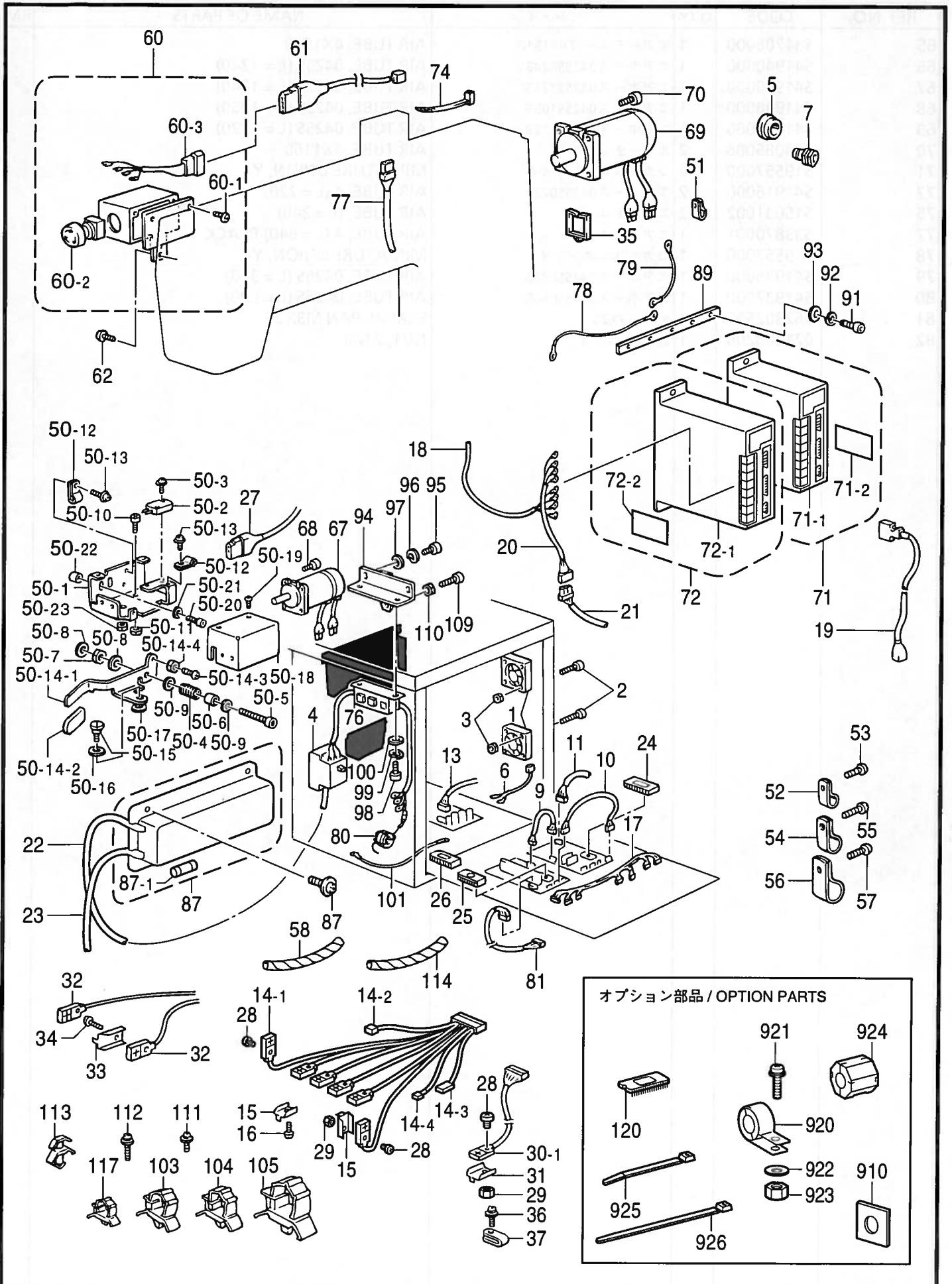

R1. 電装品関係 / Power supply equipment mechanism / Stromversorgung
 / Mécanisme de l'équipement en alimentation électrique
 / Mecanismo del equipo de alimentación de corriente

REF.NO.	CODE	Q'TY	ヒンメイ	NAME OF PARTS	RM
1	S16566000	2	クーリングファン	COOLING FAN	
2	S32294001	8	アナボルト4X35	BOLT, SOCKET M4X35	
3	021400206	8	2シユナツト4	NUT, 2 M4	
4	S38819000	1	ブレーカEA33/5	BREAKER, EA33/5	
5	S38820000	2	ブツシユ35	BUSHING, 35	
6	S10333000	2	ファンコード	FAN CORD	
7	152510000	1	コードブツシユ	CORD BUSH	
9	S40456000	1	RS-XYハーネス	RS-XY HARNESS	
10	S40457000	1	シンクロハーネス	SYNCHRONIZER HARNESS	
11	S40458000	2	ACDRハーネス	ACDR HARNESS	
13	S40460000	1	バルブハーネスクミ	VALVE HARNESS ASSY	
14	S40461000	1	センサクミ	SENSOR ASSY	
14-1	S40462000	6	センサGL-12L	SENSOR, GL-12L	
14-2	S40500000	1	セットセンサハーネス	SET SENSOR HARNESS	
14-3	S41961000	1	アツリヨクSWハーネス	PRESSURE SWITCH HARNESS	
14-4	S41963000	1	ルーフオリSWハーネス	SWITCH HARNESS, LOOP FOLD	
15	S46476001	6	センサカナグ	SENSOR BRACKET	
16	062301006	4	ナベコ3X10	SCREW, PAN M3X10	
17	S40464000	1	デンゲンハーネスMA	POWER SUPPLY HARNESS, MA	
18	S40467000	2	ACDR-POWハーネス	ACDR-POWER SUPPLY HARNESS	
19	S40468000	2	ACDR-SIGハーネス	ACDR-SIGNAL HARNESS	
21	S41972000	2	ACDRデンゲンハーネスB	ACDR-POWER SUPPLY HARNESS, B	
22	S40510000	1	デンゲンハーネスFDF	POWER SUPPLY HARNESS, FDF	
23	S41967000	1	デンゲンハーネスFA	POWER SUPPLY HARNESS, FA	
24	S40469000	1	PROMメインクミ	PROM MAIN ASSY	
25	S40470000	1	PROMXYメイン	PROM, XY1	
26	S40471000	1	PROMXYモータ	PROM, XY2	
27	S40472000	1	スタートSWハーネス	START SWITCH HARNESS	
28	002301203	3	+ナベコ3X12	SCREW, PAN M3X12	
29	021300206	7	2シユナツト3	NUT, 2 M3	
30	S43402000	1	ソウチスイッチ	SENSOR ASSY	
30-1	S40462000	1	センサGL-12L	SENSOR, GL-12L	
31	S46476001	1	センサカナグ	SENSOR BRACKET	
32	S40463000	2	センサGL-12L-A	SENSOR, GL-12L-A	
33	S46476001	1	センサカナグ	SENSOR BRACKET	
34	062300806	1	ナベコ3X8	SCREW, PAN M3X8	
35	S41964000	1	ブツシユ	BUSH	
36	0A5400806	1	+ナベザクミ4X8DB	SCREW, PAN (S/P WASHER) M4X8	
37	625010000	1	ナイロンランプNK-2N	CORD HOLDER, NK-2N	
50	S40485001	1	テモトスタートスイッチクミ	HAND START SWITCH ASSY	
50-1	S40449001	1	SWベース	SWITCH BASE	
50-2	S20871001	1	テモトスイッチクミ	HAND SWITCH ASSY	
50-3	0A5301405	2	+ナベザクミ3X14DB	SCREW, PAN (S/P WASHER) M3X14	
50-4	S40491001	1	SWバネ	SPRING, SWITCH	
50-5	018404036	1	アナボルト4X40	BOLT, SOCKET M4X40	
50-6	154514001	1	スペーサー	SPACER	
50-7	021400216	1	2シユナツト4	NUT, 2 M4	
50-8	025040236	2	ヒラザガネチユウ4	WASHER, PLAIN M 4	
50-9	102707002	2	ザガネ	WASHER, PLAIN 4	
50-10	018400636	1	アナボルト4X6	BOLT, SOCKET M4X6	
50-11	021400216	1	2シユナツト4	NUT, 2 M4	
50-12	S10243000	2	ナイロンランプNK-3N	CORD HOLDER, NK-3N	
50-13	060300612	2	バインド M3X6	SCREW, BIND M3X6	
50-14	S40492001	1	SWレバークミ	SWITCH LEVER ASSY	
50-14-1	S40493001	1	SWレバー	SWITCH LEVER	
50-14-2	S40494000	1	SWキャツプ	SWITCH CAP	
50-14-3	062301005	1	ナベコ3X10	SCREW, PAN M3X10	
50-14-4	021300303	1	ナツト3シユ3	NUT, 3 M3	

R1 . 電装品関係 / Power supply equipment mechanism / Stromversorgung
 / Mécanisme de l'équipement en alimentation électrique
 / Mecanismo del equipo de alimentación de corriente

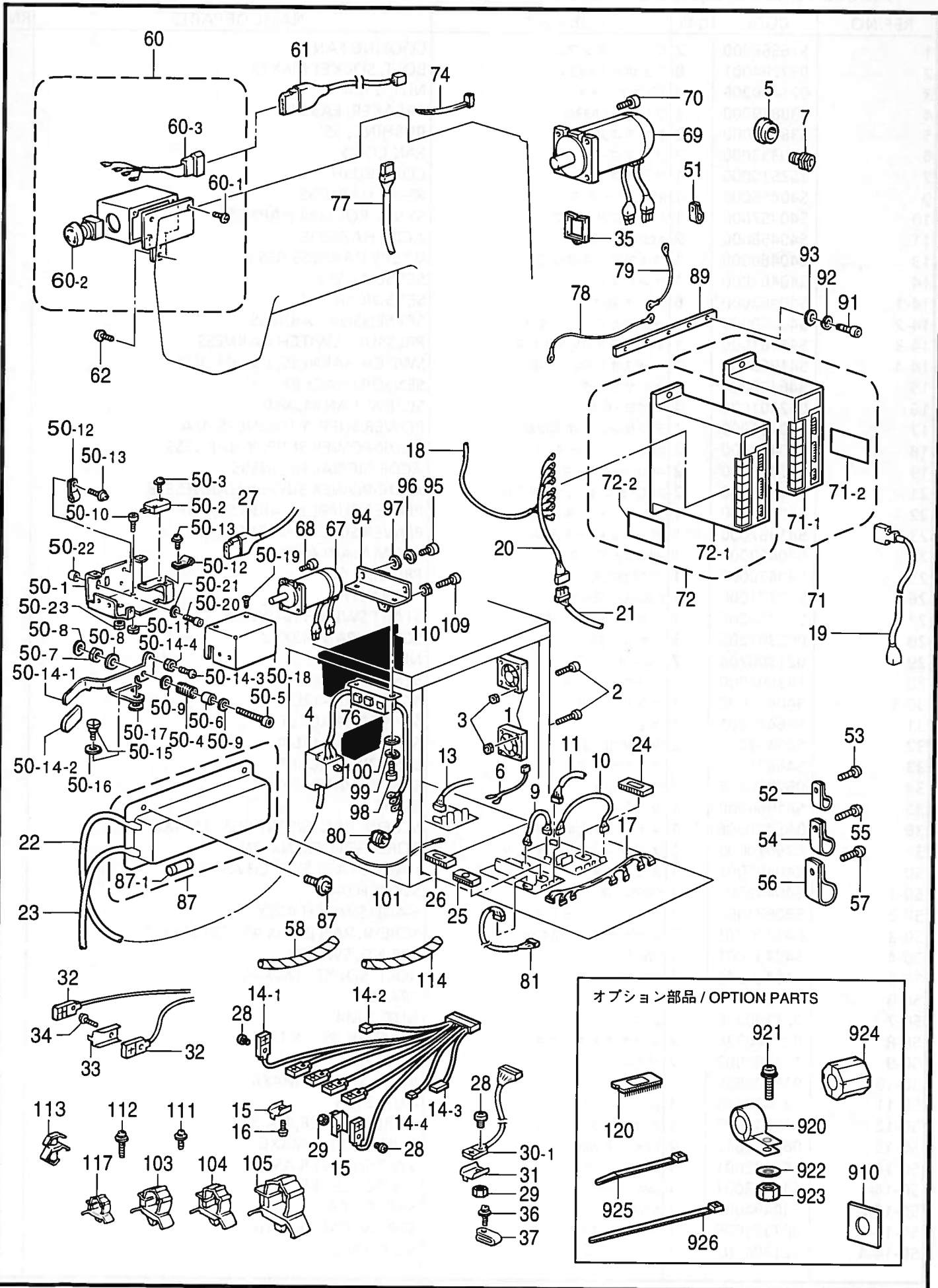

R1. 電装品関係 / Power supply equipment mechanism / Stromversorgung

/ Mécanisme de l'équipement en alimentation électrique

/ Mecanismo del equipo de alimentación de corriente

REF.NO.	CODE	Q'TY	ヒンメイ	NAME OF PARTS	RM
50-15	S07370102	1	ダンネジ5.95	SHOULDER SCREW, SM5.95	
50-16	153113001	1	スラストザガネ	THRUST WASHER	
50-17	S03695001	1	ザガネ6	WASHER, PLAIN 6	
50-18	S40495001	1	SWカバー	SWITCH COVER	
50-19	008300604	6	+トラスコ3X6	SCREW, TRUSS M3X6	
50-20	018502036	2	アナボルト5X20	BOLT, SOCKET M5X20	
50-21	025050236	2	ヒラザガネチユウ5	WASHER, PLAIN M 5	
50-22	152863001	2	クツシヨンカラー	CUSHION COLLAR	
50-23	106588003	1	ナツト5.95	NUT, SM5.95	
51	149547000	1	コードオサエ	CORD HOLDER, 4N	
52	S00480000	2	コードホルダ#5	CORD HOLDER, 5N	
53	052400806	2	ナベコバネヒラ4X8	SCREW, PAN (S/P WASHER) M4X8	
54	525567000	1	コードホルダ#8	CORD HOLDER, 8N	
55	052400806	1	ナベコバネヒラ4X8	SCREW, PAN (S/P WASHER) M4X8	
56	554482000	1	コードホルダ#12	CORD HOLDER, 12N	
57	052400806	1	ナベコバネヒラ4X8	SCREW, PAN (S/P WASHER) M4X8	
58	S11763000	1	スパイラル100S	SPIRAL TUBE, 100S	
60	S40513009	1	EM口ツクSWクミ	EM-LOCK SWITCH ASSY	
60-1	008300604	2	+トラスコ3X6	SCREW, TRUSS M3X6	
60-2	S32335000	1	SW-AVS311N	SWITCH, AVS311N	
60-3	S40473000	1	EM口ツクSWハーネス	EM-LOCK SWITCH HARNESS	
61	S40474000	1	EMSWハーネス	EM-SWITCH HARNESS	
62	062710812	2	ナベコ476-32X8	SCREW, PAN SM4.76-32X8	
63	S10243000	2	ナイロンクランプNK-3N	CORD HOLDER, NK-3N	
64	062670612	2	ナベコ357-40X6	SCREW, PAN SM3.57-40X6	
65	025350236	2	ヒラザガネチユウ3.5	WASHER, PLAIN M 3.5	
67	S40475000	1	ACサーボモータ100	AC-SERVO MOTOR, 100	
68	018301236	4	アナボルト3X12	BOLT, SOCKET M3X12	
69	S40476000	1	ACサーボモータ750	AC-SERVO MOTOR, 750	
70	018501636	4	アナボルト5X16	BOLT, SOCKET M5X16	
71	S44823001	1	サーボDR705シタクミ	AC-SERVO ASSY, LOWER	
71-1	S44832001	1	サーボDRラベル705シタ	LABEL, SERVO DR 705 (LOWER)	
72	S44822001	1	サーボDR705ウエクミ	AC-SERVO ASSY, UPPER	
72-1	S44831001	1	サーボDRラベル705ウエ	LABEL, SERVO DR 705 (UPPER)	
74	S04557000	20	ハンタイPLTIM	BAND, PLTIM	
76	S40486000	1	デンゲンSWクミ	POWER SUPPLY SWITCH ASSY	
77	S40509000	1	イトマキハーネス	BOBBIN WINDER HARNESS	
78	S11733000	2	アースセン1700	GROUND WIRE, 1700	
79	S38145000	1	アースセン2	GROUND WIRE, 2	
80	S40497000	1	アースインダクタ	GROUND INDUCTOR	
81	S40481000	1	イトキリエンチヨウハーネス	EXTENDED HARNESS, THR. TRIMMER	
87	S40503000	1	EMCBOXクミ	BOX ASSY, EMC	
87-1	J02469001	3	カンヒューズ10A250V	GLASS FUSE, 10A250V	
88	0A5401006	4	ナベコバネヒラ4X10	SCREW, PAN (S/P WASHER) M4X10	
89	S41965001	2	ドライバササエイタ	DRIVER SUPPORT PLATE	
91	018401236	10	アナボルト4X12	BOLT, SOCKET M4X12	
92	028040246	10	バネザガネ2-4	WASHER, SPRING 2-4	
93	025040236	10	ヒラザガネチユウ4	WASHER, PLAIN M 4	
94	S41889001	1	SWトリツケイタ	SWITCH SETTING PLATE	
95	018400836	2	アナボルト4X8	BOLT, SOCKET M4X8	
96	028040246	2	バネザガネ2-4	WASHER, SPRING 2-4	
97	025040236	2	ヒラザガネチユウ4	WASHER, PLAIN M 4	
98	018400836	2	アナボルト4X8	BOLT, SOCKET M4X8	
99	028040246	2	バネザガネ2-4	WASHER, SPRING 2-4	
100	025040236	2	ヒラザガネチユウ4	WASHER, PLAIN M 4	
101	157270101	2	アースコードクミD	GROUND WIRE ASSY, D	
103	S09142000	24	コードクランプ20L	CORD CLAMP, 20-L	
104	S31760000	8	CKSクランプ26L	CORD CLAMP, 26L	

R1 . 電装品関係 / Power supply equipment mechanism / Stromversorgung
 / Mécanisme de l'équipement en alimentation électrique
 / Mecanismo del equipo de alimentación de corriente

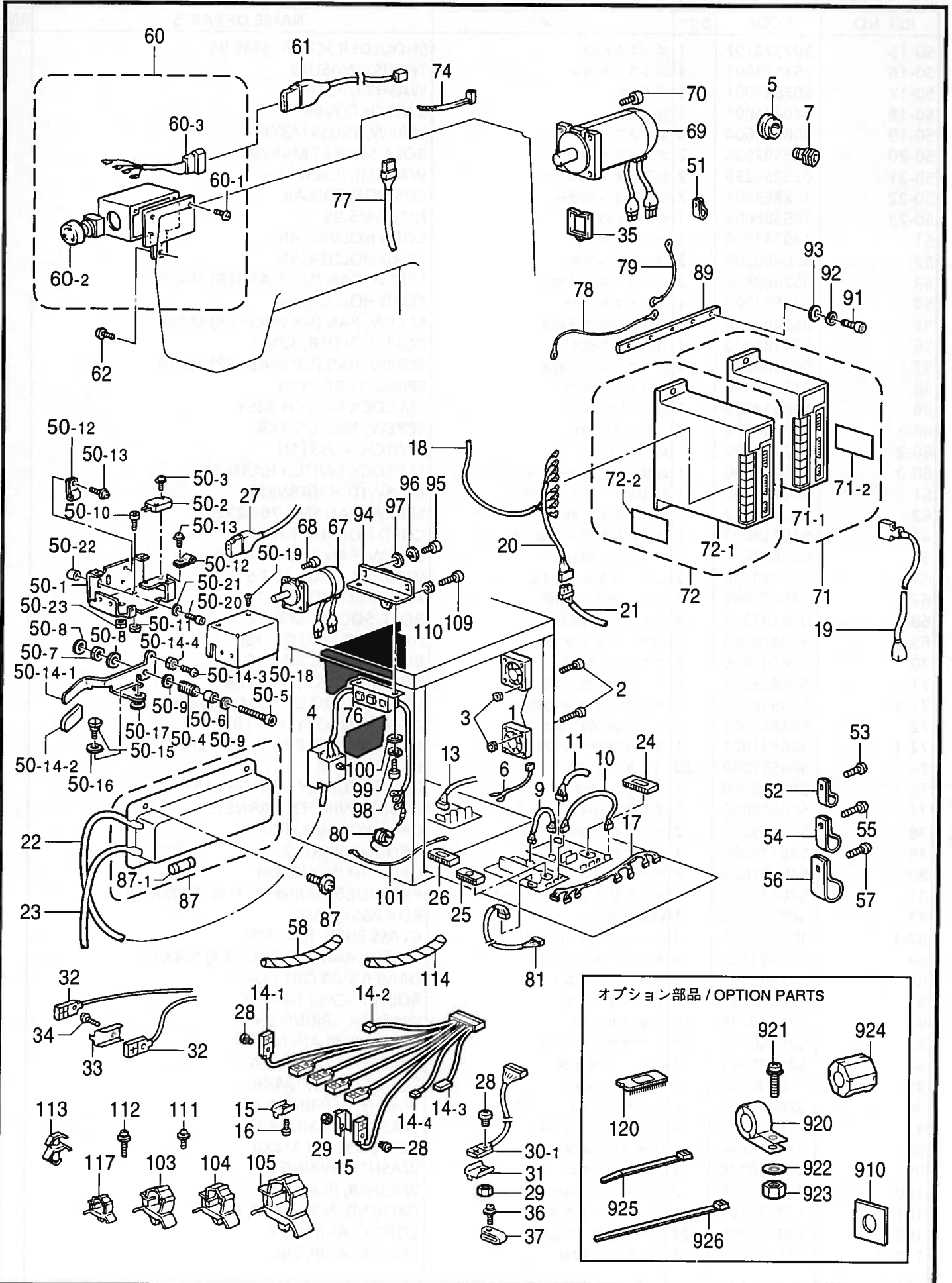

R1. 電装品関係 / Power supply equipment mechanism / Stromversorgung
 / Mécanisme de l'équipement en alimentation électrique
 / Mecanismo del equipo de alimentación de corriente

REF.NO.	CODE	Q'TY	ヒンメイ	NAME OF PARTS	RM
105	S17024000	5	CKSクランプ20-H	CORD CLAMP, 20-H	
109	018402036	1	アナボルト4X20	BOLT, SOCKET M4X20	
110	021400206	1	2シユナツト4	NUT, 2 M4	
111	052400606	2	ナベコバネヒラ4X6	SCREW, PAN (S/P WASHER) M4X6	
112	052401605	1	ナベコバネヒラ4X16	SCREW, PAN (S/P WASHER) M4X16	
113	S00554000	12	サポート6NS	SUPPORT, 6NS	
114	S11763000	1	スパイラル100S	SPIRAL TUBE, 100S	
115	228475000	1	ケツソクバンド1.9X80	FASTENING BAND, 1.9X80	
117	150349001	1	コードクランプ10	CORD CLAMP, 10-L	
120	S46502000	1	" オプション部品 "	" OPTION PARTS "	
910	S37057001	1	PROM705CKクミ	PROM ASSY, I/O CHECK 705	
920	S40623000	1	EMスイッチスヘーサ3	EM SWITCH SPACER, 3	
921	0A5401605	4	EMIコアTR-40-27	EMI CORE, TR-40-27	
922	025040236	4	+ナベザクミ4X16DB	SCREW, PAN (S/P WASHER) M4X16	
923	021400106	4	ヒラザガネチユウ4	WASHER, PLAIN M 4	
924	S40622000	4	ナツト1シユ4	NUT, 1 M4	
925	S04557000	4	EMIコアESD-SR-25	EMI CORE, ESD-SR-25	
926	149809000	2	ハンタイPLTIM	BAND, PLTIM	
		1	タイラツPL	BEAD BAND, L	

R2 . 電装品関係 / Power supply equipmet mechanism / Stromversorgung
 / Mécanisme de l'équipement en alimentation électrique
 / Mecanismo del equipo de alimentación de corriente

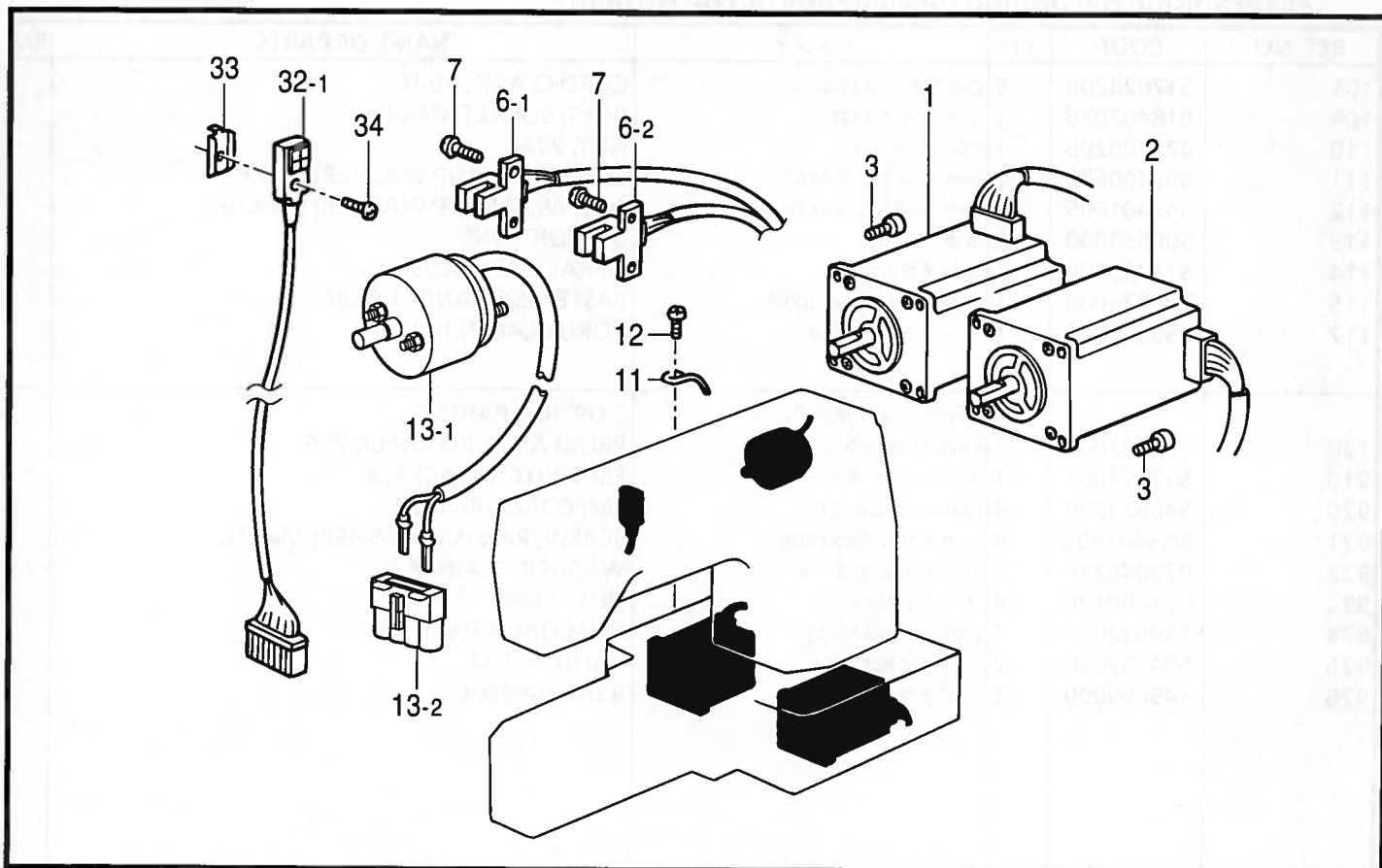

118-705-515

S . 付属装置関係 (オプション部品) / Attachment set (Option parts)
 / Anbausatz (Sonderzubehöön) / Jeu d'accessoires (Pièces en option)
 / Juego de fijación (Piezas opcionales)

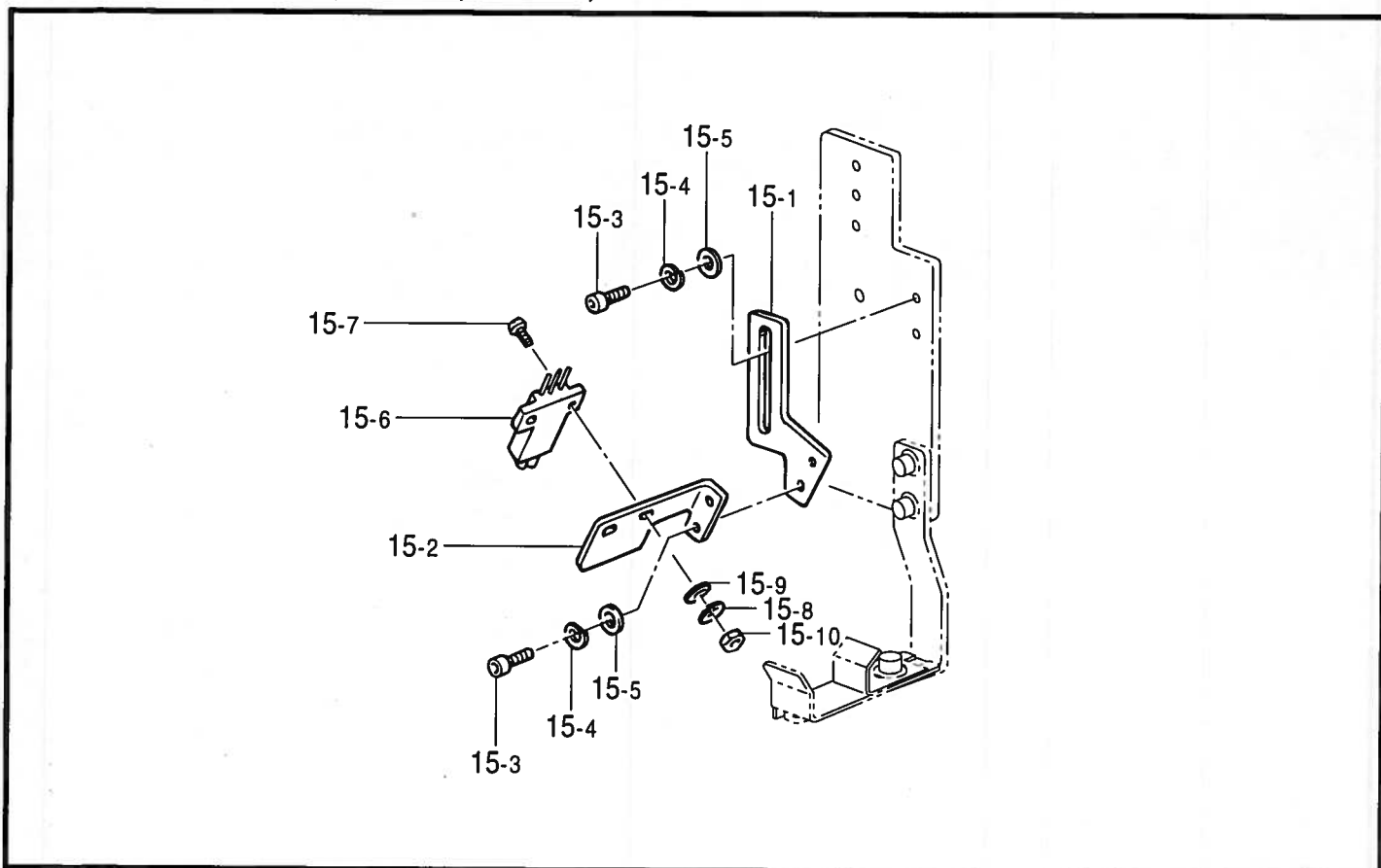

151-705-940

R2. 電装品関係 / Power supply equipment mechanism / Stromversorgung

/ Mécanisme de l'équipement en alimentation électrique

/ Mecanismo del equipo de alimentación de corriente

REF.NO.	CODE	Q'TY	ヒンメイ	NAME OF PARTS	RM
1	S41975000	1	ハルスモータXクミ	PULSE MOTOR ASSY, X	
2	S41976000	1	ハルスモータYクミ	PULSE MOTOR ASSY, Y	
3	018401222	8	アナボルト4X12	BOLT, SOCKET M4X12	
5	0A5401006	2	ナベコバネヒラ4X10	SCREW, PAN (S/P WASHER) M4X10	
6	S40431000	1	トウブセンサクミ	HEAD SENSOR ASSY	
6-1	S40432000	1	ゲンテンセンサXハーネス	HOME POSITION SENSOR HARNESS, X	
6-2	S40433000	1	ゲンテンセンサYハーネス	HOME POSITION SENSOR HARNESS, Y	
7	0A4300605	4	+ナベザクミ3X6DA	SCREW, PAN (S/P WASHER) M3X6	
11	117150001	2	コードササエカネ	CORD SUPPORT	
12	062670512	2	ナベコ357-40X5	SCREW, PAN SM3.57-40X5	
13-1	S38144100	1	イトキリソレノイドクミ	THREAD TRIMMER SOLENOID ASSY	
13-2	S38146000	1	コネクタ3191-04R	CONNECTOR, 3191-04R	
32	S40435000	1	センサクミ	SENSOR ASSY	
32-1	S40436000	1	センサGL-12L	SENSOR, GL-12L	
33	S40437000	1	センサカナグ	SENSOR BRACKET	
34	062300806	3	ナベコ3X8	SCREW, PAN M3X8	

118-705-515

S. 付属装置関係 (オプション部品) / Attachment set (Option parts)

/ Anbausatz (Sonderzubehör) / Jeu d'accessoires (Pièces en option)

/ Juego de fijación (Piezas opcionales)

REF.NO.	CODE	Q'TY	ヒンメイ	NAME OF PARTS	RM
15	S41959001	1	<ループセット検知用> ループセットセンサークミ	<For loop setting detector> LOOP SET SENSOR ASSY	
15-1	S41628001	1	センサーシジイタ1	SENSOR SUPPORT PLATE, 1	
15-2	S41629001	1	センサーシジイタ2	SENSOR SUPPORT PLATE, 2	
15-3	018400636	4	アナボルト4X6	BOLT, SOCKET M4X6	
15-4	028040246	4	バネザガネ2-4	WASHER, SPRING 2-4	
15-5	025040236	4	ヒラザガネチユウ4	WASHER, PLAIN M 4	
15-6	S31930000	1	フラップセンサ	FLAP SENSOR	
15-7	062301006	2	ナベコ3X10	SCREW, PAN M3X10	
15-8	028030246	2	バネザガネ2-3	WASHER, SPRING 2-3	
15-9	025030236	2	ヒラザガネチユウ3	WASHER, PLAIN M 3	
15-10	021300206	2	2シユナツト3	NUT, 2 M3	

151-705-940

T. プリント基板関係 / Printed circuit board mechanism / Leiterplatten / Circuits imprimés
 / Tableros de circuitos impresos

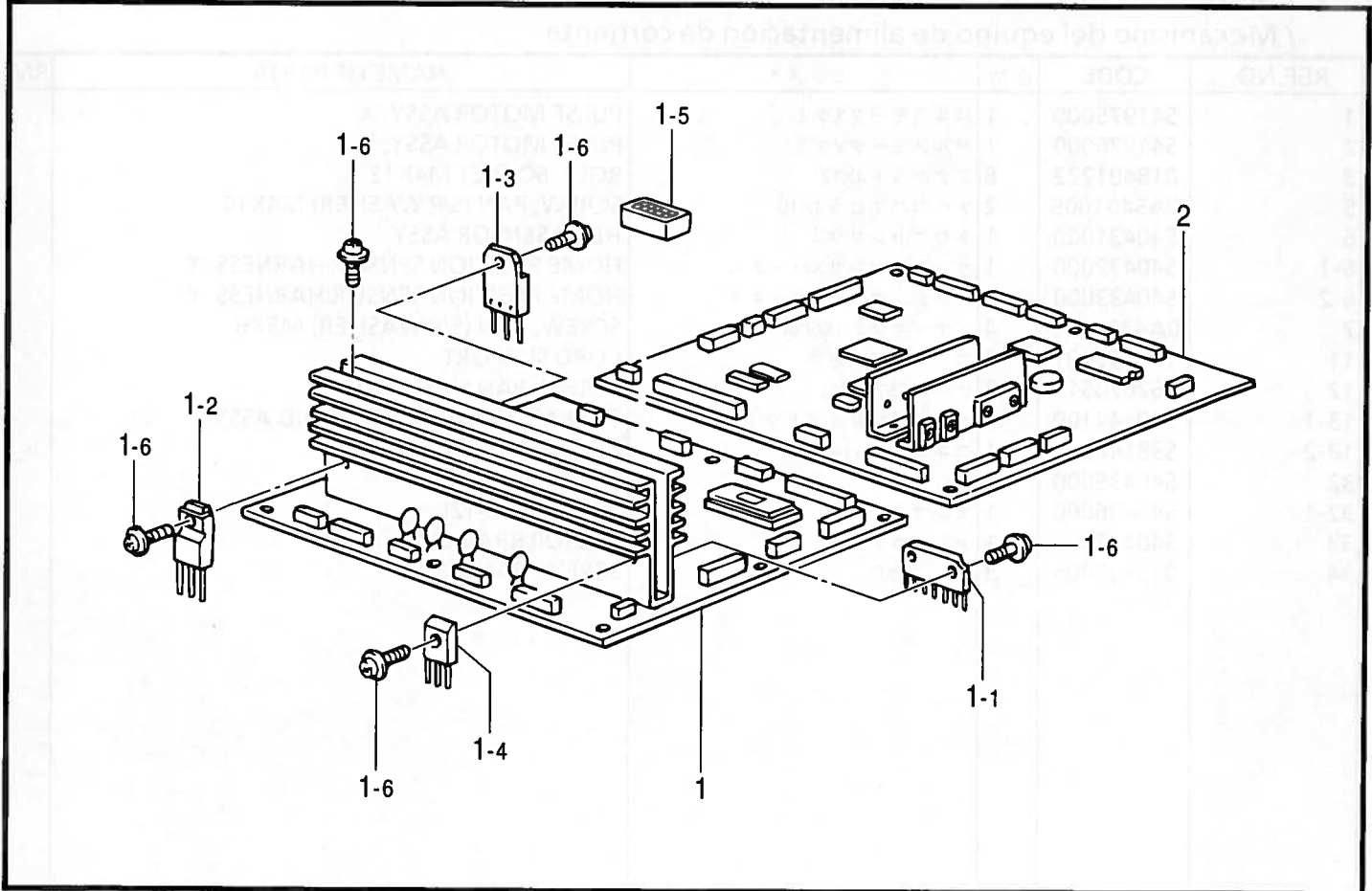

151-705-518

U. 頭部部品関係 / Machine head parts / Teile des maschinenberteils
 / Pièces supérieures de la machine / Piezas de la cabeza de la máquina

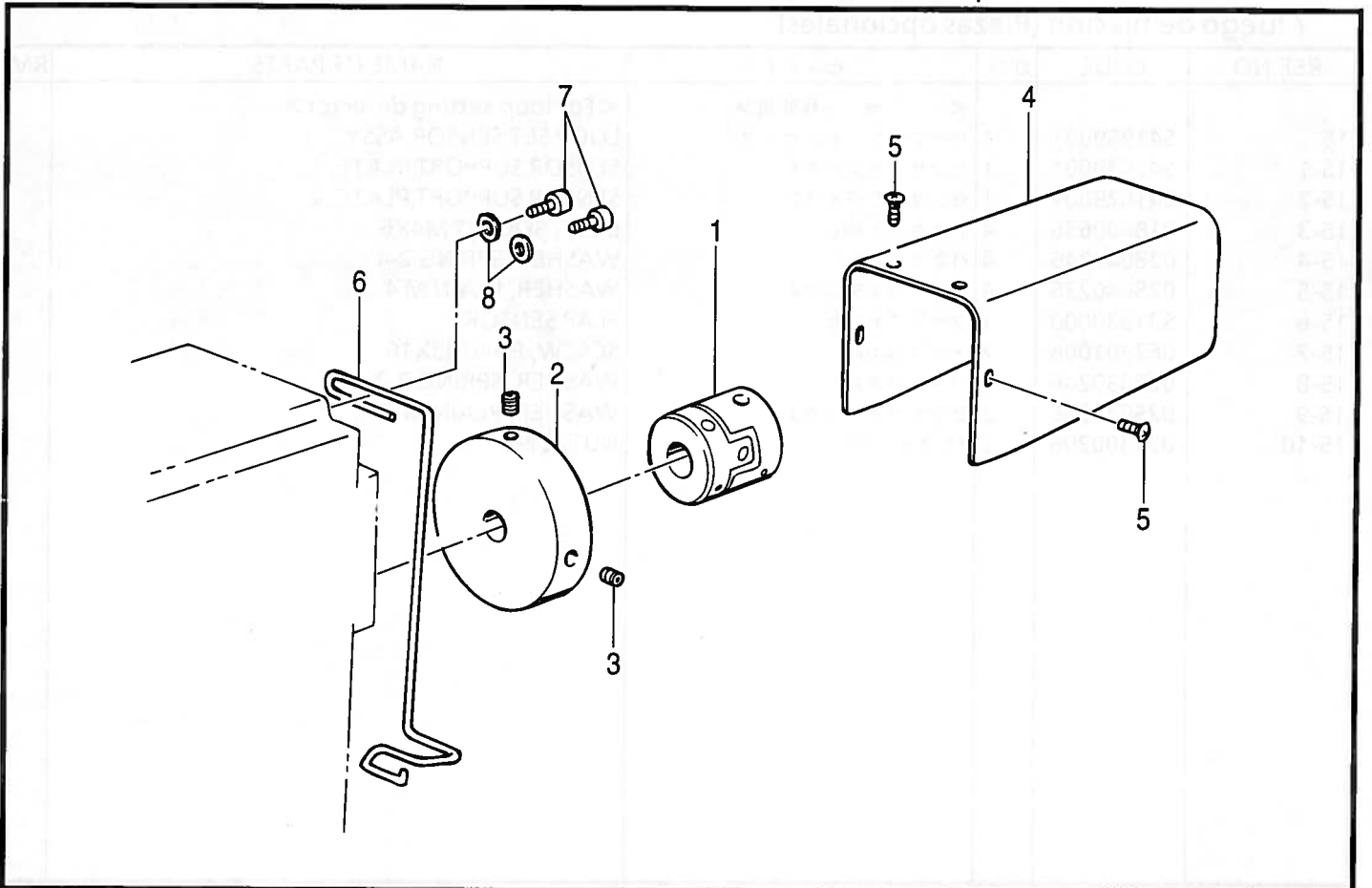

151-705-601

T. プリント基板関係 / Printed circuit board mechanism / Leiterplatten / Circuits imprimés
/ Tableros de circuitos impresos

REF.NO.	CODE	Q'TY	ヒンメイ	NAME OF PARTS	RM
1	S38151001	1	<X-Y送り基板用> メインキバンクミ	<For Prited circuit board for "X-Y feeding"> MAIN PCB ASSY	
1-1	S38154000	4	BIPICSLA4390	BIP IC, SLA4390	
1-2	S38155000	3	MOSFET2SK1306	MOS FET, 2SK1306	
1-3	S38164000	6	MOSFET2SK1937	MOSFET2SK1937	
1-4	S33849000	8	FRDアレイ D8LD20U	FRD ARRAY D8LD20U	
1-5	U32744000	1	DIPSWDSS708	DIP SWITCH:DSS708	
1-6	0A4301005	27	+ナベザクミ 3X10DA	SCREW, PAN (S/P WASHER) M3X10	
2	S40489101	1	<メイン基板用> メインキバンクミ	<For Main printed circuit board> MAIN PCB ASSY	

151-705-518

U. 頭部部品関係 / Machine head parts / Teile des maschinenoberteils
/ Pièces supérieures de la machine / Piezas de la cabeza de la máquina

REF.NO.	CODE	Q'TY	ヒンメイ	NAME OF PARTS	RM
1	S41881000	1	カップリング19	COUPRING, 19	
2	S41882001	1	ハンドプーリ	HAND PULLEY	
3	012060636	2	アナヒラ6X6	SET SCREW, SOCKET (FT) M6X6	
4	S41883009	1	ウワジクモーターカバー	UPPER SHAFT MOTOR COVER	
5	008400604	4	+トラスコ4X6	SCREW, TRUSS M4X6	
6	S41884001	1	ループアンナイ	LOOP GUIDE	
7	018401222	2	アナボルト4X12	BOLT, SOCKET M4X12	
8	146354001	2	ザガネ	WASHER, PLAIN 5	

151-705-601

V . 動力台関係 / Power table / Motorgestell / Mécanisme du plateau de la machine
 / Mecanismo de la mesa de la máquina

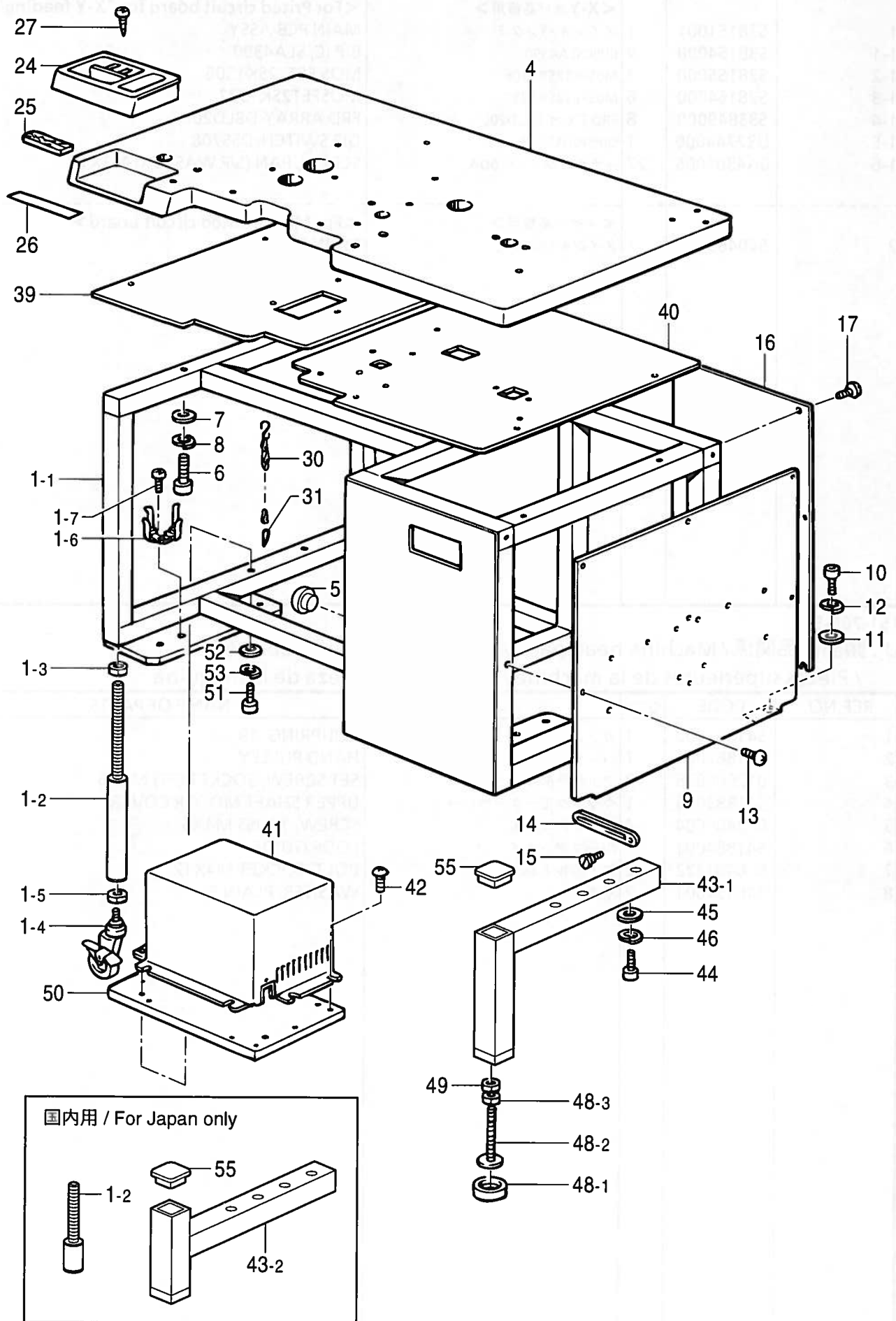

国内用 / For Japan only

1-2

43-2

55

V. 動力台関係 / Power table / Motorgestell / Mécanisme du plateau de la machine
/ Mecanismo de la mesa de la máquina

REF.NO.	CODE	Q'TY	ヒンメイ	NAME OF PARTS	RM
1	S41885009	1	<輸出用> -----	<For Export> STAND FRAME ASSY, I	
1-2	S41894001	4	-----	ADJUSTTING SCREW, L	
1	S41886009	1	<国内用> キヤクフレームクミD	<For Japan only> -----	
1-2	S41893001	4	チヨウセツネジS	-----	
1-1	S41887009	1	キヤクフレーム	STAND FRAME	
1-3	021200203	4	ナツト2シユ20	NUT, 2 M20	
1-4	152393200	4	キヤスター	CASTER	
1-5	021160303	4	ナツト3シユ16	NUT, 3 M16	
1-6	133172003	1	アブラサシダイ	OIL BRACKET	
1-7	062501006	1	ナベコ5X10	SCREW, PAN M5X10	
4	S41888009	1	テーブル705	TABLE, 705	
5	159150009	2	ゴムセン20.5	RUBBER CAP, 20.5	
6	018082036	6	アナボルト8X20	BOLT, SOCKET M8X20	
7	025080236	6	ヒラザガネチユウ8	WASHER, PLAIN M 8	
8	028080246	6	バネザガネ2-8	WASHER, SPRING 2-8	
9	S41890009	1	ソクメンカバー	FRAME SIDE COVER	
10	018400836	6	アナボルト4X8	BOLT, SOCKET M4X8	
11	025040236	6	ヒラザガネチユウ4	WASHER, PLAIN M 4	
12	028040246	6	バネザガネ2-4	WASHER, SPRING 2-4	
13	008400604	5	+トラスコ4X6	SCREW, TRUSS M4X6	
14	S41891001	2	トビラステー	DOOR STAY	
15	S21306001	4	ダンネジ6	STUD SCREW 6	
16	S41892009	1	ハイメンカバー	REAR COVER	
17	008400604	6	+トラスコ4X6	SCREW, TRUSS M4X6	
24	S15158009	1	コモノケース	ACCESSORY CASE	
25	S02740000	1	フェルト	FELT	
26	S02739000	1	ゴムジシャクテープ	RUBBER MAGNET TAPE	
27	039411215	2	1トラスタツピン4X12	TAPPING SCREW, TRUSS 1 M4X12	
30	S41895001	1	クサリクミ	CHAIN ASSY	
31	S41909000	1	フック	HOOK	
39	S41896000	1	アースイタL	GROUND PLATE, L	
40	S41897000	1	アースイタR	GROUND PLATE, R	
43-1	S41899009	2	<輸出用> -----	<For Export> SUB-STAND, A	
43-2	S41900009	2	<国内用> ホジヨキヤクB	<For Japan only> SUB-STAND, B	
44	018081636	4	アナボルト8X16	BOLT, SOCKET M8X16	
45	025080236	4	ヒラザガネチユウ8	WASHER, PLAIN M 8	
46	028080246	4	バネザガネ2-8	WASHER, SPRING 2-8	
48	S01265001	2	レベルザクミ	LEVEL ADJUSTER ASSY	
48-1	S01004000	2	キヤクゴムウシロ	RUBBER	
48-2	153769001	2	レベルザ	LEVEL ADJUSTER	
48-3	022120306	2	ナツト3シユ12	NUT, 3 M12	
49	022120306	2	ナツト3シユ12	NUT, 3 M12	
55	S24194009	2	ハリエンドキヤツブ	BEAM END CAP	
41	S41898009	1	<輸出用> -----	<For Export "3-Phase 230V over"> TRANSFORMER COVER, THREE PHASE	
42	008400604	8	-----	SCREW, TRUSS M4X6	
50	S41910009	1	-----	SETTING PLATE, TRANSFORMER	
51	018061036	4	-----	BOLT, SOCKET M6X10	
52	025060236	4	-----	WASHER, PLAIN M 6	
53	028060246	4	-----	WASHER, SPRING 2-6	

W1 . 付属装置関係 (オプション部品) / Attachment set (Option parts)
 / Anbausatz (Sonderzubehör) / Jeu d'accessoires (Pièces en option)
 / Juego de fijación (Piezas opcionales)

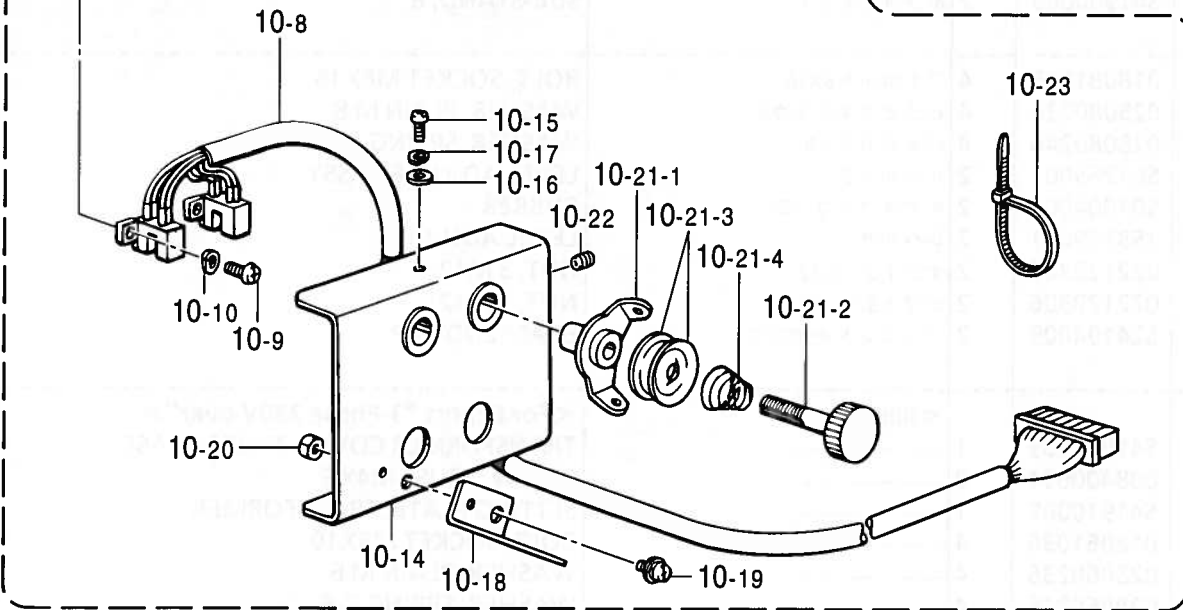
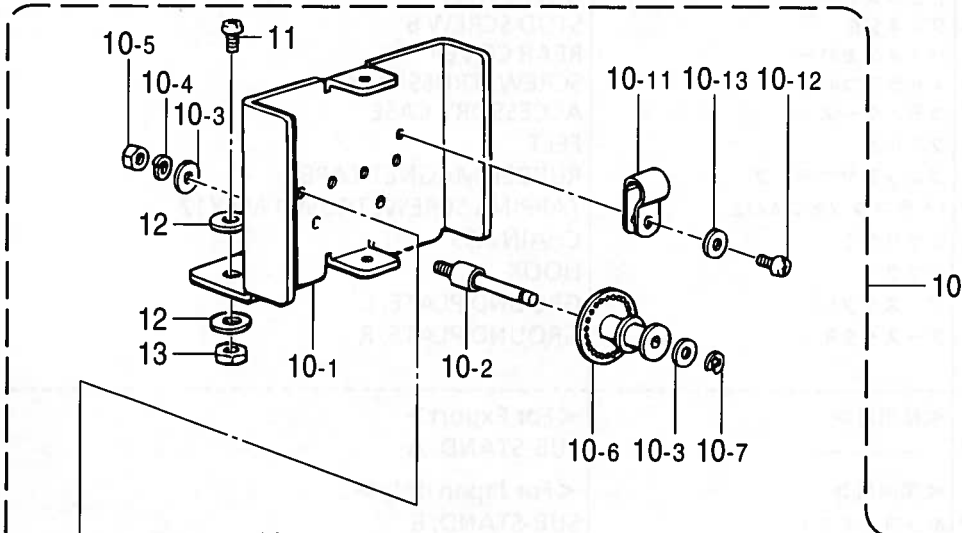
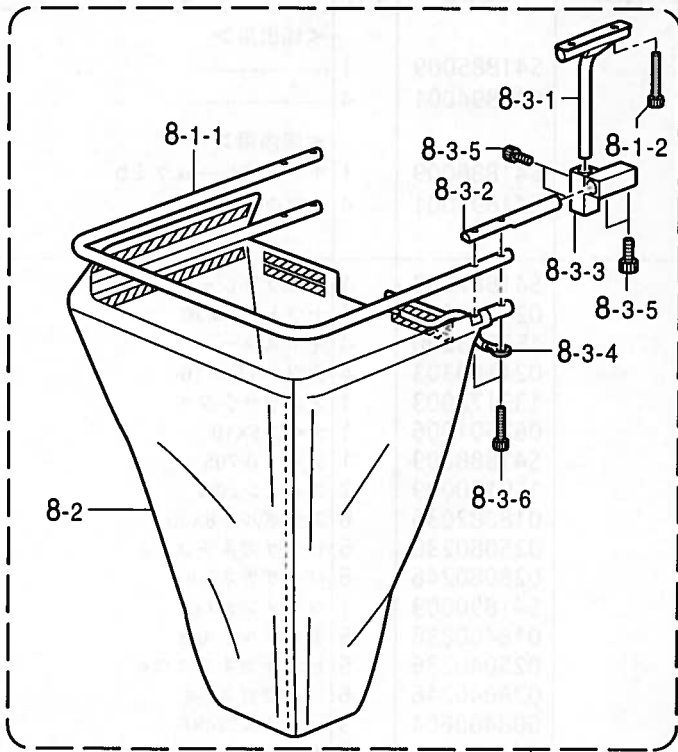
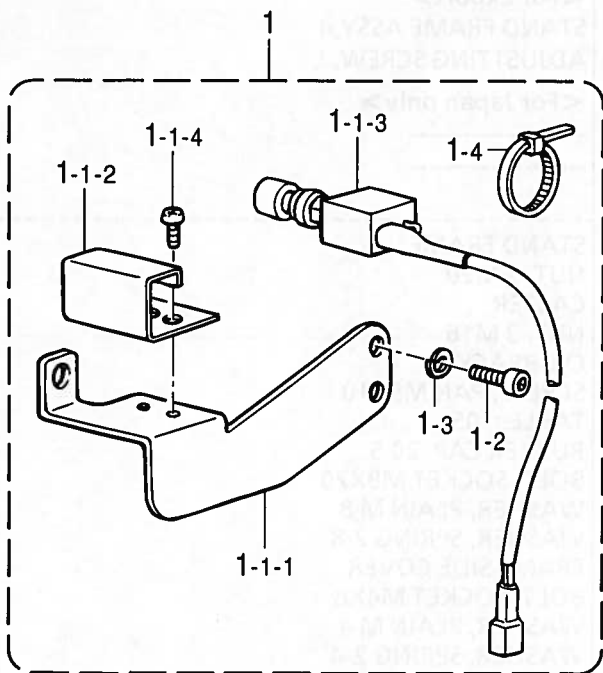

W1. 付属装置関係 (オプション部品) / Attachment set (Option parts)
 / Anbausatz (Sonderzubehör) / Jeu d'accessoires (Pièces en option)
 / Juego de fijación (Piezas opcionales)

REF.NO.	CODE	Q'TY	ヒンメイ	NAME OF PARTS	RM
			<手動ループ折込スイッチ>	<Hand operation SW for folding the loop>	
1	S41639001	1	ハンドセットスイッチソウクミ	HAND SET SWITCH DEVICE	
1-1	S41640001	1	ハンドセットスイッチクミ	HAND SET SWITCH ASSY	
1-1-1	S41638001	1	ハンドスイッチダイ	HAND SWITCH BASE	
1-1-2	S14972001	1	ハンドSWカバー	HAND SWITCH COVER	
1-1-3	S40496000	1	ハンドSWクミ	HAND SWITCH ASSY	
1-1-4	008300604	2	+トラスコ3X6	SCREW, TRUSS M3X6	
1-2	018400636	2	アナボルト4X6	BOLT, SOCKET M4X6	
1-3	028040246	2	バネザガネ2-4	WASHER, SPRING 2-4	
1-4	S04557000	3	ハンタイPLTIM	BAND, PLTIM	
			<切り屑処理装置>	<Clipping disposal funnel assembly>	
8	S41776001	1	チヨウセツクズシヨリソウクミ	ADJUSTING C-DISPOSAL DEVICE	
8-1	S41906001	1	クリクズシヨリクミ	CLIPPING DISPOSAL FUNNEL ASSY	
8-1-1	S41907001	2	ミゴロウケバー	CLOTH SUPPORT BAR	
8-1-2	018065022	4	アナボルト6X50	BOLT, SOCKET M6X50	
8-2	S41908001	1	クリクズシヨリフクロ	CLIPPING DISPOSAL FUNNEL	
8-3	S41744001	1	チヨウセツソウチクミ	ADJUSTING DEVICE SET	
8-3-1	S41732009	2	ジヨウゲバー	VERTICAL BAR	
8-3-2	S41739001	2	ゼンゴバー	BAR	
8-3-3	S41740009	2	チヨウセツブロック	ADJUSTING BLOCK	
8-3-4	S41743000	1	フクロカケケーブル	CABLE	
8-3-5	018081236	8	アナボルト8X12	BOLT, SOCKET M8X12	
8-3-6	018063036	4	アナボルト6X30	BOLT, SOCKET M6X30	
			<上糸切れ検知装置>	<Upper thread breakage detector>	
10	S40520009	1	ウワイトギレケンチクミ	U-TR. BREAKAGE DETECTOR ASSY	
10-1	S09400009	1	トリツケダイ	SETTING BRACKET	
10-2	S09401001	2	シテンジク	FULCRUM SHAFT	
10-3	025030233	4	ヒラザガネチユウ3	WASHER, PLAIN M 3	
10-4	028030243	2	バネザガネ2-3	WASHER, SPRING 2-3	
10-5	021300103	2	ナツト1シユ3	NUT, 1 M3	
10-6	S09402101	2	フーリー	PULLEY	
10-7	048020342	2	トメワE2	RETAINING RING, E2	
10-8	S40519000	1	イトキレセンサークミ	THREAD BREAKAGE SENSOR ASSY	
10-9	062300616	4	ナベコM3X6	SCREW, PAN M3X6	
10-10	028030243	4	バネザガネ2-3	WASHER, SPRING 2-3	
10-11	S00480000	1	コードホルダ#5	CORD HOLDER, 5N	
10-12	062400616	1	ナベコM4X6	SCREW, PAN M4X6	
10-13	025040233	1	ヒラザガネチユウ4	WASHER, PLAIN M 4	
10-14	S09403009	1	カバー	COVER	
10-15	062300616	2	ナベコM3X6	SCREW, PAN M3X6	
10-16	025030233	2	ヒラザガネチユウ3	WASHER, PLAIN M 3	
10-17	028030243	2	バネザガネ2-3	WASHER, SPRING 2-3	
10-18	S03566001	1	メンイタイトカケ	FACE PLATE THREAD HOOK	
10-19	052400806	1	ナベコバネヒラ4X8	SCREW, PAN (S/P WASHER) M4X8	
10-20	021400202	1	2シユナツト4	NUT, 2 M4	
10-21	183377001	2	フレテンションクミA	PRE-TENSION ASSY, A	
10-21-1	S02611001	2	イトアンナイ	THREAD GUIDE	
10-21-2	S02612001	2	イトアンナイチヨウシボウ	PRE-TENSION STUD	
10-21-3	144504001	2	イトアンナイサラ	THREAD GUIDE DISC	
10-21-4	154560001	2	フレテンションバネA	SPRING, PRE-TENSION (A)	
10-22	014500522	2	アナトメネジ5クボミ	SET SCREW, SOCKET (CP) M5	
10-23	S04557000	1	ハンタイPLTIM	BAND, PLTIM	
11	062761212	2	ナベコ595-28X12	SCREW, PAN SM5.95-28X12	
12	025060232	4	ヒラザガネチユウ6	WASHER, PLAIN M 6	
13	100022005	2	ナツト5.95	NUT, SM5.95	

W2 . 付属装置関係 (オプション部品) / Attachment set (Option parts)
 / Anbausatz (Sonderzubehör) / Jeu d'accessoires (Pièces en option)
 / Juego de fijación (Piezas opcionales)

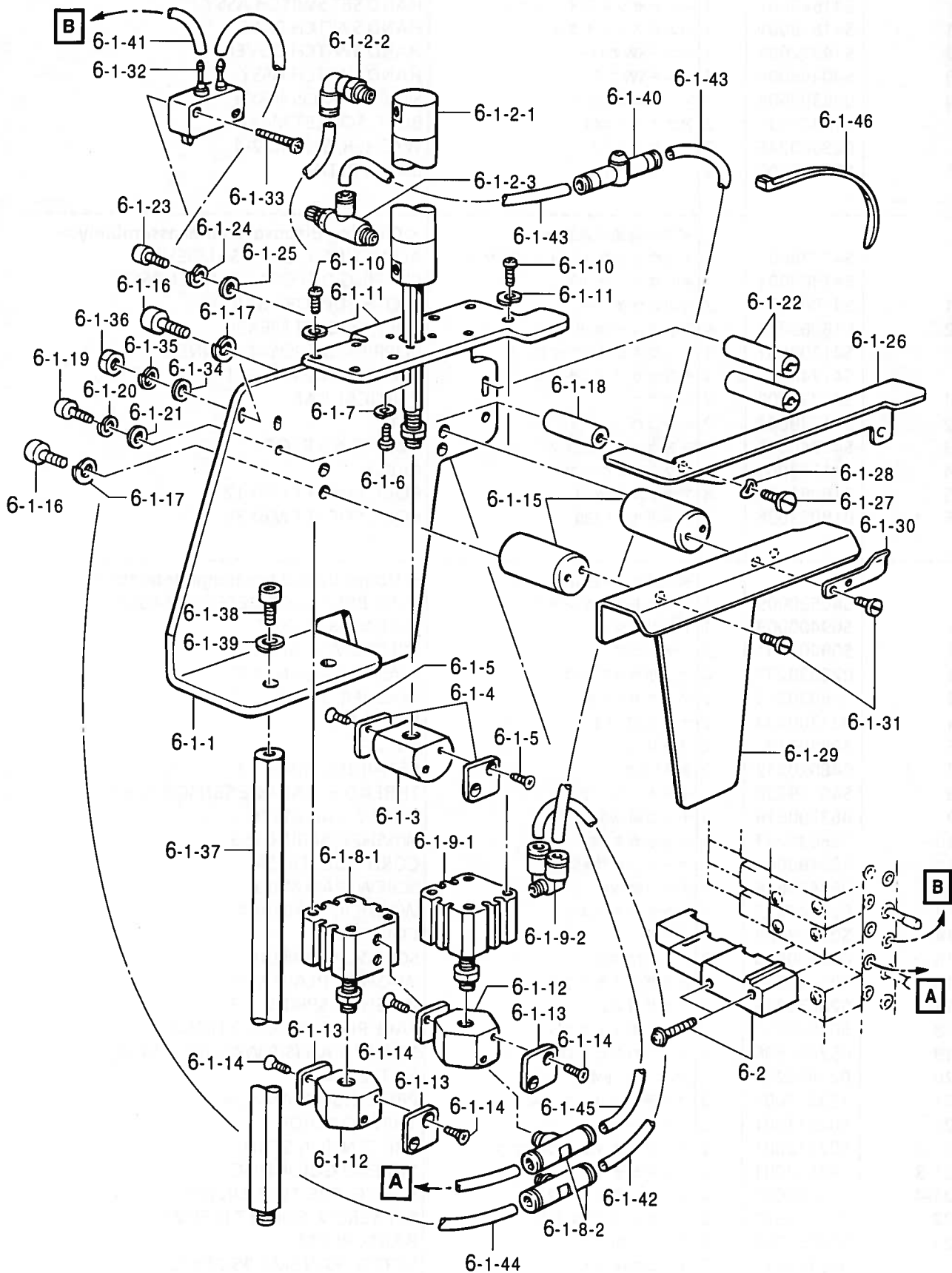

W2. 付属装置関係(オプション部品) / Attachment set (Option parts)
 / Anbausatz (Sonderzubehör) / Jeu d'accessoires (Pièces en option)
 / Juego de fijación (Piezas opcionales)

REF.NO.	CODE	Q'TY	ヒンメイ	NAME OF PARTS	RM
			<ベルトスラック装置>	<Belt feed device>	
6	S43632001	1	ベルトスラックソウチクミ	BELT FEED DEVICE	
6-1	S43622001	1	ベルトスラックソウチコクミ	BELT FEED DEVICE, SUB	
6-1-1	S43611001	1	ベルトオクリドダイ	BELT FEED BASE	
6-1-2	S43623000	1	シリンダ20-125クミ	CYLINDER ASSY, 20-125	
6-1-2-1	S43624000	1	シリンダ20-125	CYLINDER, 20-125	
6-1-2-2	S04909000	1	エルボユニオン	ELBOW UNION	
6-1-2-3	S23647000	1	スピードコントローラ	SPEED CONTROLLER	
6-1-3	S43612001	1	ベルトアンナイ	BELT GUIDE	
6-1-4	S43613000	2	スヘーサ	SPACER	
6-1-5	061300616	4	サラコ3X6	SCREW, FLAT M3X6	
6-1-6	062401016	4	ナベコ4X10	SCREW, PAN M4X10	
6-1-7	028040246	4	バネザガネ2-4	WASHER, SPRING 2-4	
6-1-8	S43625000	1	シリンダ16-5クミ	CYLINDER ASSY, 16-5	
6-1-8-1	S43627000	1	シリンダ16-5	CYLINDER, 16-5	
6-1-8-2	S43628000	2	チーズツギテ4M5	T-JOINT, 4M5	
6-1-9	S43629000	1	シリンダ16-5クミ	CYLINDER ASSY, 16-5	
6-1-9-1	S43630000	1	シリンダ16-5	CYLINDER, 16-5	
6-1-9-2	S43631000	1	ブランチエルボ4M5	BRANCH ELBOW, 4M5	
6-1-10	062401416	8	ナベコ4X14	SCREW, PAN M4X14	
6-1-11	028040246	8	バネザガネ2-4	WASHER, SPRING 2-4	
6-1-12	S43614001	2	ベルトオサエ	BELT PRESSER	
6-1-13	S43613000	4	スヘーサ	SPACER	
6-1-14	061300616	8	サラコ3X6	SCREW, FLAT M3X6	
6-1-15	S43615001	2	ガイドジクB	GUIDE SHAFT, B	
6-1-16	018501236	4	アナボルト5X12	BOLT, SOCKET M5X12	
6-1-17	028050246	4	バネザガネ2-5	WASHER, SPRING 2-5	
6-1-18	S43616001	1	ガイドジクA	GUIDE SHAFT, A	
6-1-19	018401236	1	アナボルト4X12	BOLT, SOCKET M4X12	
6-1-20	028040246	1	バネザガネ2-4	WASHER, SPRING 2-4	
6-1-21	025040236	1	ヒラザガネチユウ4	WASHER, PLAIN M 4	
6-1-22	S43617001	2	ガイドジクC	GUIDE SHAFT, C	
6-1-23	018401236	2	アナボルト4X12	BOLT, SOCKET M4X12	
6-1-24	028040246	2	バネザガネ2-4	WASHER, SPRING 2-4	
6-1-25	025040236	2	ヒラザガネチユウ4	WASHER, PLAIN M 4	
6-1-26	S43619001	1	アンナイカバー	GUIDE COVER	
6-1-27	S35221001	1	ダンネジM4	SHOULDER SCREW, M4	
6-1-28	107017002	1	ナミバネザガネ	WASHER, WAVE SPRING 6.45	
6-1-29	S43618001	1	アンナイイタ	GUIDE PLATE	
6-1-30	S43620001	1	オサエバネ	SPRING, PLATE	
6-1-31	008400604	3	+トラスコ4X6	SCREW, TRUSS M4X6	
6-1-32	S01557000	1	マイクロメカバルブD	MICRO VALVE, D	
6-1-33	062302016	2	ナベコM3X20	SCREW, PAN M3X20	
6-1-34	025030233	2	ヒラザガネチユウ3	WASHER, PLAIN M 3	
6-1-35	028030243	2	バネザガネ2-3	WASHER, SPRING 2-3	
6-1-36	021300103	2	ナツト1シユ3	NUT, 1 M3	
6-1-37	S43621001	2	ポスト	POST	
6-1-38	018061236	2	アナボルト6X12	BOLT, SOCKET M6X12	
6-1-39	028060246	2	バネザガネ2-6	WASHER, SPRING 2-6	
6-1-40	S37445000	1	クイツクエキゾースト	QUICK EXHAUST	
6-1-41	S15031006	2	エアーチューブ	AIR TUBE, L = 1400	
6-1-42	S14085005	1	エアーチューブ	AIR TUBE, 4X145	
6-1-43	S14085012	2	エアーチューブ	AIR TUBE, 4X73	
6-1-44	S15031001	1	エアーチューブ	AIR TUBE, L = 120	
6-1-45	S18387003	1	エアーチューブ	AIR TUBE, 4 (L = 260)	
6-1-46	S04557000	2	ハンタイPLTIM	BAND, PLTIM	
6-2	S39115000	1	バルブVQZ1151-5	VALVE, VQZ1151-5	

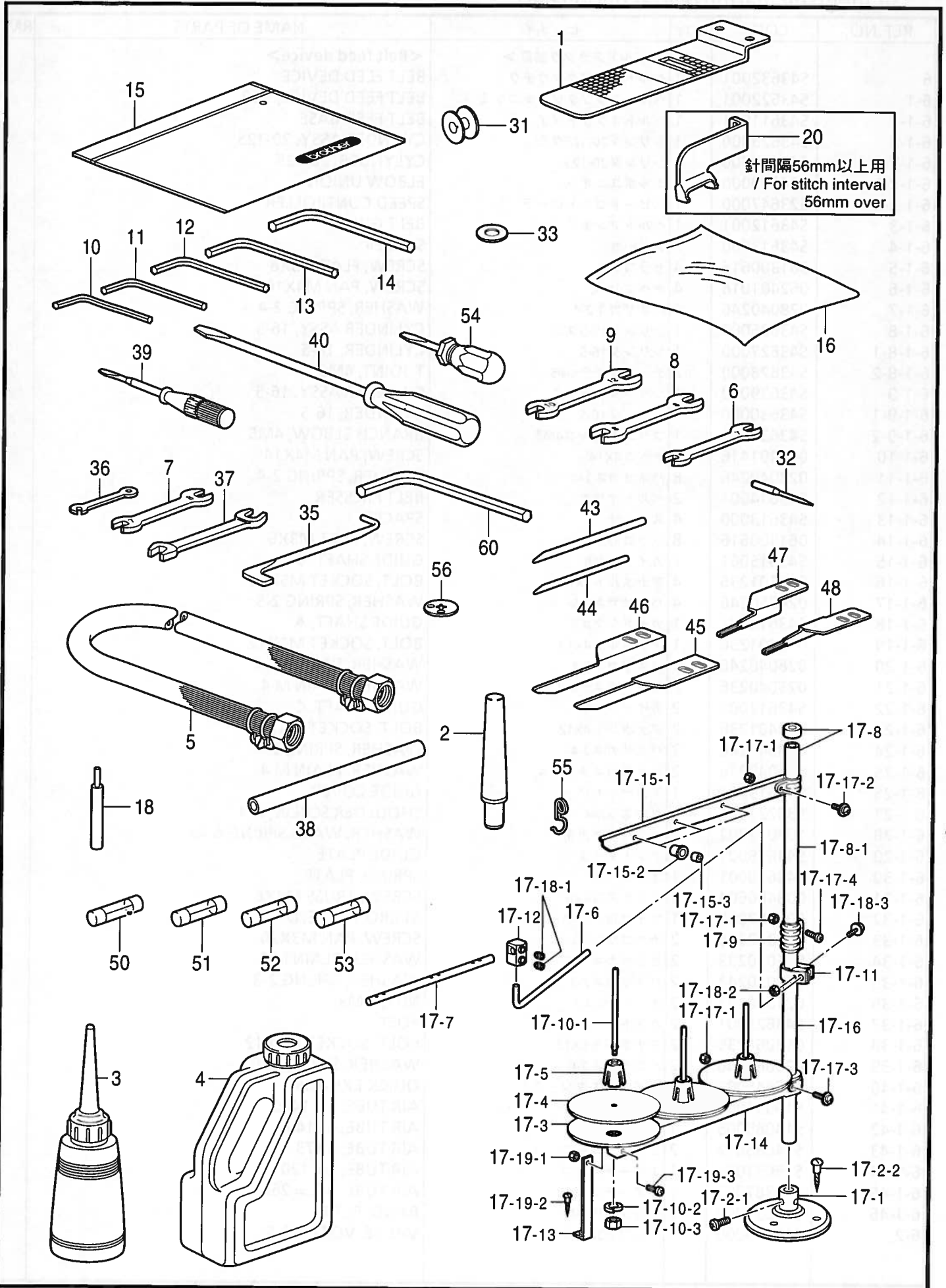

Z. 付属品関係 / Accessories / Zubehör / Accessoires / Accesorios

REF.NO.	CODE	Q'TY	ヒンメイ	NAME OF PARTS	RM
1	S41803001	1	オクリイタ	FEED PLATE	
2	S41901009	1	マクラクミ	HEAD REST ASSY	
3	114483002	1	ホリオイラークミ	OILER ASSY	
4	154702101	1	オイルタンク	OIL TANK	
5	149796001	1	ゴムホースカナグツキ	AIR TUBE WITH CONNECTOR	
6	107779001	1	スハナ6X7	WRENCH, 6X7	
7	142205001	1	スハナ7X8	WRENCH, 7X8	
8	100887001	1	スハナ8X9	WRENCH, 8X9	
9	107780001	1	スハナ10X12	WRENCH, 10X12	
10	142002001	1	6カクボウスハナ2	HEXAGONAL WRENCH, 2	
11	154125001	1	6カクボウスハナ2.5	HEXAGONAL WRENCH, 2.5	
12	142721001	1	6カクボウスハナ3	HEXAGONAL WRENCH, 3	
13	118064001	1	6カクボウスハナ4	HEXAGONAL WRENCH, 4	
14	150335001	1	6カクボウスハナ5	HEXAGONAL WRENCH, 5	
15	122991001	1	フゾクヒンホリフクロ	ACCESSORY BAG	
16	120192000	1	N0115ホリフクロ	PE. BAG, 78X80	
17	S02767309	1	イトタテダイクミ3THF	COTTON STAND ASSY, 3THF	
17-1	150189109	1	ブラケット	COTTON STAND BASE	
17-2	S02773001	1	ブラケットネジセット	COTTON STAND BRACKET SCREW SET	
17-2-1	062060806	2	ナベコ6X8	SCREW, PAN M6X8	
17-2-2	031452206	3	マルモク45X22	WOOD SCREW, ROUND M4.5X22	
17-3	150180001	3	ウケザラ	SPOOL STAND BASE	
17-4	150182000	3	スプールマット	SPOOL MAT	
17-5	126863001	3	スプールクッション	SPOOL CUSHION	
17-6	S04109001	1	イトアンナイササエボウ	THREAD GUIDE SUPPORT BAR	
17-7	142997001	1	イトアンナイ3	THREAD GUIDE, 3	
17-8	S40639001	1	コラムハイブキャップツキ	COLUMN PIPE WITH CAP	
17-8-1	150172003	1	コラムハイブ	COLUMN PIPE	
17-9	150173003	1	コラムジョイント	COLUMN JOINT	
17-10	S21798001	3	スプールネジセット	SPOOL SCREW SET	
17-10-1	150179002	3	スプールジクB	SPOOL SHAFT, B	
17-10-2	028050246	3	バネザガネ2-5	WASHER, SPRING 2-5	
17-10-3	021500106	3	1シユナツト5	NUT, 1 M5	
17-11	150185009	1	イトアンナイホルダー	THREAD GUIDE HOLDER	
17-12	138843001	1	ササエボウツギテ	JOINT	
17-13	150188009	1	スプールホルダーササエA	SPOOL HOLDER SUPPORT, A	
17-14	S02779009	1	スプールホルダー3	SPOOL HOLDER, 3	
17-15	S02788009	1	スレツドハンガークミ3	THREAD HANGER ASSY, 3	
17-15-1	S02789009	1	スレツドハンガー3	THREAD HANGER, 3	
17-15-2	150183000	3	イトカケハンガーダイ	THREAD HANGER BASE	
17-15-3	142990001	3	スレツドブツシュ	THREAD BUSH	
17-16	150172003	1	コラムハイブ	COLUMN PIPE	
17-17	S40641001	1	スプールジクネジセットA	SPOOL SCREW SET, A	
17-17-1	021500106	4	1シユナツト5	NUT, 1 M5	
17-17-2	S37038001	1	ナベコヒラザ5X14	SCREW, PAN (S/P WASHER) M5X14	
17-17-3	S37037001	1	ナベコヒラザ5X32	SCREW, PAN (S/P WASHER) M5X32	
17-17-4	062501406	2	ナベコ5X14	SCREW, PAN M5X14	
17-18	S40643001	1	ホルダーツギテネジセット	HOLDER JOINT SCREW SET	
17-18-1	014060632	2	アナトメ6X6クボミ	SET SCREW, SOCKET (CP) M6X6	
17-18-2	021500106	1	1シユナツト5	NUT, 1 M5	
17-18-3	S37037001	1	ナベコヒラザ5X32	SCREW, PAN (S/P WASHER) M5X32	
17-19	S40644001	1	ホルダーツギテネジセット	HOLDER JOINT SCREW SET	
17-19-1	021500106	1	1シユナツト5	NUT, 1 M5	

151-705-910

- ◎ 付属品の明細は変更することがあります。
- ◎ The details of included accessories are subject to change.
- ◎ Änderungen in der Aufstellung der Mitgelieferten Zubehöre sind vorbehalten.
- ◎ Les détails des accessoires inclus sont sujets à des changements.
- ◎ Los detalles de accesorios incluidos pueden variar.

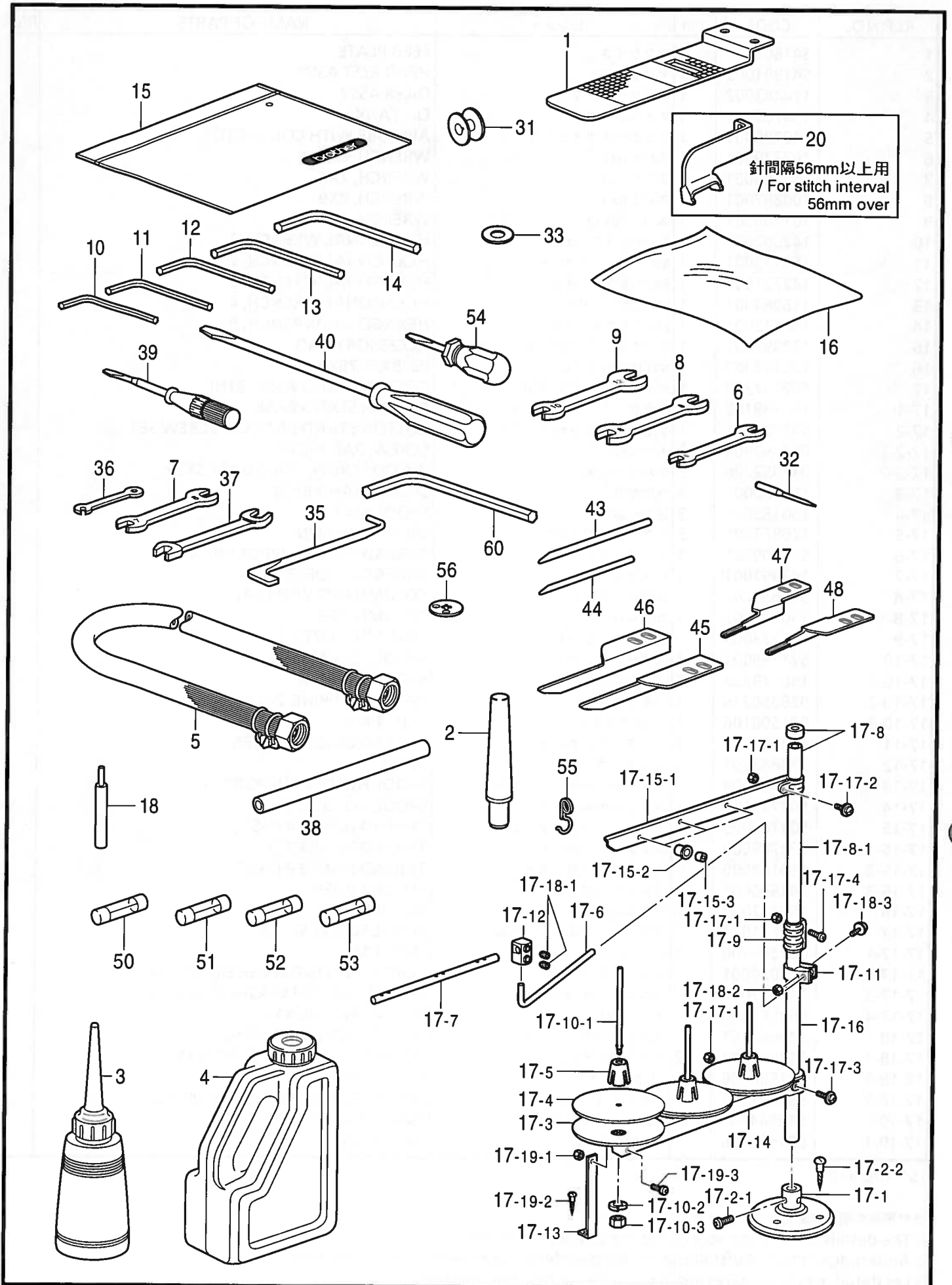

Z. 付属品関係 / Accessories / Zubehör / Accessoires / Accesorios

REF.NO.	CODE	Q'TY	ヒンメイ	NAME OF PARTS	RM
17-19-2	031452206	1	マルモク45X22	WOOD SCREW, ROUND M4.5X22	
17-19-3	062501006	1	ナベコ5X10	SCREW, PAN M5X10	
18	S41903001	1	ハリアナジグ	NEEDLE HOLE JIG	
20	S41605101	1	<針間隔56mm以上用> ウエガイドイタB	<For stitch interval 56mm over> UPPER GUIDE PLATE, B	
31	S15665001	4	ボビンLA	BOBBIN, LA	
32	S37928419	1	ミシンハリDP17NY19クミ	NEEDLE ASSY, DPX17NY (#19)	
33	S10208001	2	イドウハカンザ <t=0.4>	WASHER, MOVABLE KNIFE T = 0.4 <t=0.4>	
33	S10208002	2	イドウハカンザ <t=0.5>	WASHER, MOVABLE KNIFE T = 0.5 <t=0.5>	
33	S10208003	2	イドウハカンザ <t=0.6>	WASHER, MOVABLE KNIFE T = 0.6 <t=0.6>	
35	S08170001	1	Zガタネジマワシ	SCREW DRIVER, Z-STEEL	
36	S23926001	1	スハナ5	WRENCH, 5	
37	S14696001	1	スハナ11X13	WRENCH, 11X13	
38	154760001	1	ボウスハナパイプ	PIPE, WRENCH	
39	118837001	1	ネジマワシ3.4X70	SCREW DRIVER, 3.4X70	
40	101572101	1	ネジマワシ5.5X190	SCREW DRIVER, 5.5X190	
43	S41626001	2	ホークジク2.0L	FORK SHAFT, 2.0L	
44	S41627001	2	ホークジク2.0S	FORK SHAFT, 2.0S	
45	S44968001	1	ループオサエイタB	LOOP PRESSER PLATE, B	
46	S44969001	1	ループオサエイタF	LOOP PRESSER PLATE, F	
47	S44970001	1	ユルメオサエB	LOOSEN LOOP PRESSER FOOT, B	
48	S44971001	1	ユルメオサエF	LOOSEN LOOP PRESSER FOOT, F	
50	215769001	1	カンヒューズ3A	FUSE, 3A	
51	152566000	3	ヒューズC	FUSE, C 2A	
52	153242000	1	ヒューズ6A	FUSE, 6A	
53	157219000	2	カンヒューズ5A-D	FUSE, 5A	
54	S11243001	1	スタビードライバー	SCREW DRIVER	
55	S02747101	3	イトカケバネ	SPRING	
56	S45188001	2	ハリアナイタEX	NEEDLE HOLE PLATE, EX	
60	115157001	1	6カクボウスハナ6	HEXAGONAL WRENCH, 6	

151-705-910

- ◎ 付属品の明細は変更することがあります。
- ◎ The details of included accessories are subject to change.
- ◎ Änderungen in der Aufstellung der Mitgelieferten Zubehöre sind vorbehalten.
- ◎ Les détails des accessoires inclus sont sujets à des changements.
- ◎ Los detalles de los accesorios incluidos pueden variar.

Ga . ゲージ部品一覧表 / Gauge parts List / Lehrenliste / Liste des Pièces de cartment / Lista d'ePiezas de calibradores

<p>Ref No.1 ※</p>	<p>Ref No.2</p>	<p>Ref No.3 ※</p>	<p>Ref No.4</p>
<p>Ref No.5</p>	<p>Ref No.6</p>	<p>Ref No.7</p>	<p>Ref No.8</p>
<p>Ref No.9 ※</p>	<p>Ref No.10 ※</p>	<p>Ref No.11</p>	<p>Ref No.12</p>
<p>Ref No.13 ※</p>	<p>Ref No.14</p>		
<p>Ref No.15</p>	<p>Ref No.16</p>		

Ga. ゲージ部品一覧表 / Gauge parts List / Lehrenliste / Liste des Pièces decartment / Lista d'ePiezas de calibradores

REF.NO.	CODE	Q'TY	ヒンメイ	NAME OF PARTS	RM
1	S10211001	1	ハリアナイタA	NEEDLE HOLE PLATE, A	
2	S29997001	1	ハリアナイタD	NEEDLE HOLE PLATE, D	
3	S10212101	1	<デニム用> ハリアナイタE	<For Denim> NEEDLE HOLE PLATE, E	※
4	S30925001	1	ハリアナイタED	NEEDLE HOLE PLATE, ED	
5	S10213001	1	ハリアナイタF	NEEDLE HOLE PLATE, F	
6	S30926001	1	ハリアナイタFD	NEEDLE HOLE PLATE, FD	
7	S30450001	1	ハリアナイタH	NEEDLE HOLE PLATE, H	
8	S25127001	1	ハリアナイタL	NEEDLE HOLE PLATE, L	
9	S45188001	1	<太糸縫製用> ハリアナイタEX	<In case of using the heavy weight thread> NEEDLE HOLE PLATE, EX	※
10	S41796101	2	<門止長さ23mm未満用> オサエ	<For bar tack length "Max. 23mm"> WORK CLAMP	※
11	S44762001	1	<門止長さ22mm未満用> オサエF	<For bar tack length "Max. 22mm"> WORK CLAMP, F	
12	S44763001	1	<門止長さ16mm未満用> オサエFS	<For bar tack length "Max. 16mm"> WORK CLAMP, FS	
13	S41803001	1	<送り板用ブランク材> オクリイタ	<Blank plate for "feed plate"> FEED PLATE	※
14	S449610XX	1	" 針間隔 = XX " <針間隔40~53mm用> オクリイタS	" Stitch interval = XX " <For stitch interval "40~53mm"> FEED PLATE, S	
15	S449620XX	1	<針間隔48~63mm用> オクリイタM	<For stitch interval "48~63mm"> FEED PLATE, M	
16	S449630XX	1	<針間隔58~70mm用> オクリイタL	<For stitch interval "58~70mm"> FEED PLATE, L	



151-705

- ☆ ※印の部品は、標準部品です。
- ☆ The ※ symbol is for Standar parts.
- ☆ Mit dem Zeichen ※ Standardteile bezeichnet.
- ☆ Le symbol ※ correspond aux pièces.
- ☆ El asterisco ※ es para piezas normales.

Wa 1. 警告ラベル / Warning labels / Warnschilder / Etiquettes d'avertissement / Etiquetas de advertencia

警告ラベル / Warning labels	品名 / Name of Parts	Size(mm)	Code
	電撃ラベル・和	40X64	S38353-101
	Label, elec. shock 4 lang.	35X118	S38352-101
	操作注意ラベル・BAS和	40X64	S38357-001
		52X84	S38357-002
	Label, operation (BAS) Eng.	40X64	S38571-001
		52X84	S38571-002
	はさみ込み注意ラベル・和 Label, Pinch	40X84	S38355-001
	高温ラベル Label, Entanglement.	72X59	S38351-001
	ワーニングマーク Mark, Injury	L=16	S36924-001

Wa 2. 警告ラベル / Warning labels / Warnschilder / Etiquettes d'avertissement
 / Etiquetas de advertencia

警告ラベル / Warning labels	品名 / Name of Parts	Size(mm)	Code
	矢印マーク Label, arrow	10X30	S37058-001
	PEマーク Label, PE	7.5X12.5	S37059-001
	アースマーク Label, grounding	φ 12	S37060-001

索引 / INDEX / VERZEICHNIS
/ INDEX / INDICE

CODE	REF.NO.	Page
J02469001	R1 - 87-1	58
S00480000	R1 - 52	58
	W1 - 10-11	68
S00505001	K - 2-31	42
S00554000	R1 - 113	60
S00705001	F - 75	34
	L - 47	46
S01004000	V - 48-1	66
S01265001	V - 48	66
S01557000	W2 - 6-1-32	70
S02354001	L - 23	44
S02428001	E - 14-1	30
S02611001	W1 - 10-21-1	68
S02612001	W1 - 10-21-2	68
S02652001	L - 6	44
S02654001	L - 7-1	44
S02739000	V - 26	66
S02740000	V - 25	66
S02747101	Z - 55	74
S02767309	Z - 17	72
S02773001	Z - 17-2	72
S02779009	Z - 17-14	72
S02788009	Z - 17-15	72
S02789009	Z - 17-15-1	72
S02877000	E - 14-9	30
	F - 42-11	32
S03303001	J - 2	40
S03490001	F - 36	32
S03566001	W1 - 10-18	68
S03695001	A2 - 21	4
	A2 - 38	4
	R1 - 50-17	58
S03704002	E - 13	30
S04109001	Z - 17-6	72
S04557000	Q - 27	52
	R1 - 74	58
	R1 - 925	60
	W1 - 1-4	68
	W1 - 10-23	68
	W2 - 6-1-46	70
S04891000	Q - 5	52
S04897000	Q - 20-6	52
	Q - 21-7	52
S04909000	W2 - 6-1-2-2	70
S05356000	D3 - 351	20
S06857000	Q - 6	52
S06858000	Q - 6-1	52
S06859000	Q - 6-2	52
S07071001	J - 3	40
S07129001	D4 - 425	24
S07333001	G1 - 2	36
	G2 - 16	38
S07370102	R1 - 50-15	58
S07424001	H - 3	38
S07456000	G1 - 3	36
S07488001	J - 1-10	40
S07512001	L - 25-2	44
S07553001	H - 1	38
S08125000	C2 - 13	12
S08170001	Z - 35	74
S08176000	Q - 56	52
	Q - 57	52
S08605101	J - 1-20	40

CODE	REF.NO.	Page
S08606001	J - 1-21	40
S08610101	J - 1-23	40
S09027001	F - 14	32
S09043000	G1 - 31	36
S09132051	D1 - 107	14
	D1 - 115	14
S09142000	R1 - 103	58
S09197000	A2 - 88	6
S09212001	C1 - 5-1	10
S09231000	Q - 1-1	52
S09400009	W1 - 10-1	68
S09401001	W1 - 10-2	68
S09402101	W1 - 10-6	68
S09403009	W1 - 10-14	68
S10162201	G1 - 15	36
S10195001	L - 30	44
S10202101	L - 41	44
S10205001	F - 73	34
	L - 45	44
S10208001	F - 74	34
	L - 46	44
	Z - 33	74
S10208002	F - 74	34
	L - 46	44
	Z - 33	74
S10208003	F - 74	34
	L - 46	46
	Z - 33	74
S10209101	F - 76	34
	L - 48	46
S10211001	Ga - 1	76
S10212101	F - 80	34
	L - 53	46
	Ga - 3	76
S10213001	Ga - 5	76
S10243000	R1 - 50-12	56
	R1 - 63	58
S10333000	R1 - 6	56
S10408000	P - 9	50
S10409002	P - 8	50
S10478000	G1 - 10	36
S11243001	Z - 54	74
S11244001	L - 52	46
S11426000	D1 - 118-4	14
	D2 - 153-2	16
	D2 - 157-2	16
	D2 - 225-2	17
	D3 - 320-2	20
	D3 - 348-2	20
	D4 - 494-2	25
S11440004	M - 8	48
S11733000	R1 - 78	58
S11763000	P - 20	50
	Q - 28	52
	R1 - 58	58
	R1 - 114	60
S12004000	D2 - 192	16
S12054000	D2 - 196	16
S12134001	D1 - 112	14
S13330001	D2 - 228	17
S13385001	D4 - 523	26
	D4 - 530	26
S13744001	F - 35-1	32

CODE	REF.NO.	Page
S14085001	A2 - 89	6
S14085005	W2 - 6-1-42	70
S14085008	Q - 70	54
S14085012	W2 - 6-1-43	70
S14159000	Q - 20-4	52
	Q - 21-5	52
S14473000	A2 - 23	4
S14627001	D2 - 248-4	18
S14696001	Z - 37	74
S14874000	D1 - 127	14
S14919000	D4 - 428	24
S14920000	D4 - 433	24
S14924001	D4 - 423	24
S14935001	D4 - 515	25
S14946101	D4 - 458	25
S14947101	D4 - 466	25
S14948101	D4 - 470	25
S14949101	D4 - 462	25
S14950001	D4 - 463	25
S14958101	D4 - 450	24
S14972001	W1 - 1-1-2	68
S14974001	C2 - 7-10	12
S15031001	W2 - 6-1-44	70
S15031002	Q - 75	54
S15031006	W2 - 6-1-41	70
S15056001	P - 10	50
S15158009	V - 24	66
S15665001	E - 103	30
	F - 103	34
	Z - 31	74
S15667001	E - 102-3	30
	F - 102-3	34
S15700009	D4 - 440	24
S16074101	E - 102-1	30
	F - 102-1	34
S16422001	D2 - 229	17
S16431001	C2 - 1-1-1	12
	C2 - 1-2-1	12
S16492101	E - 102-2	30
	F - 102-2	34
S16566000	R1 - 1	56
S16669000	K - 2-27	42
S17024000	R1 - 105	60
S17028000	Q - 1-4	52
S18093100	A2 - 78-4	6
	G1 - 25	36
S18387003	W2 - 6-1-45	70
S18387004	A2 - 25	4
S18387007	C2 - 12	12
S18974101	E - 102	30
	F - 102	34
S19543001	C2 - 25	12
S19557000	H - 19	38
	Q - 71	54
	Q - 78	54
	C2 - 16	12
S20164009	A1 - 5	2
S20871001	R1 - 50-2	56
S21103000	K - 2-26	42
S21306001	V - 15	66
S21527001	G1 - 14	36
S21715001	D2 - 256	17
S21716001	C2 - 7-13	12

CODE	REF.NO.	Page
S21798001	Z - 17-10	72
S23647000	W2 - 6-1-2-3	70
S23653001	D2 - 194	16
S23696101	D4 - 422	24
S23697001	D4 - 429	24
S23698001	D4 - 430	24
S23699201	D4 - 431	24
S23701101	D4 - 454	24
S23702201	D4 - 456	24
S23703101	D4 - 456-1	24
S23709001	D4 - 517	25
S23714001	D4 - 532	26
S23741000	D4 - 491-1	25
S23747001	Q - 30	52
S23794001	D4 - 556	26
S23836001	L - 7	44
S23926001	Z - 36	74
S24089001	D1 - 12	14
S24175000	D4 - 494-1	25
S24194009	V - 55	66
S24250001	D1 - 38	14
S25127001	Ga - 8	76
S27853001	D4 - 526	26
S28090001	C1 - 6-8	10
S28741000	H - 18	38
S29997001	Ga - 2	76
S30033001	L - 21-3	44
S30450001	Ga - 7	76
S30925001	Ga - 4	76
S30926001	Ga - 6	76
S31169000	Q - 1-2	52
S31170000	Q - 11	52
S31258001	D2 - 149	16
S31704000	A2 - 51	4
S31706000	F - 67	34
	Q - 59	52
	Q - 61	52
	Q - 65	54
S31760000	R1 - 104	58
S31764000	Q - 8	52
S31930000	S - 15-6	62
S31960009	K - 2-28	42
S32294001	R1 - 2	56
S32335000	R1 - 60-2	58
S33849000	T - 1-4	64
S33870001	Q - 77	54
S34844001	A1 - 85-1-1	2
S34982000	G1 - 36	36
	G2 - 4	38
S34983000	G1 - 34	36
S34986000	G1 - 11	36
	G1 - 35	36
S35001000	G2 - 12	38
S35020001	D4 - 535	26
S35032101	K - 2-6	42
S35221001	W2 - 6-1-27	70
S36070001	A1 - 85-1-4	2
S36071001	A1 - 85-1-3	2
S36924001	Wa	77
S37037001	Z - 17-17-3	72
	Z - 17-18-3	72
S37038001	Z - 17-17-2	72
S37057001	A1 - 910	2

CODE	REF.NO.	Page
S37057001	R1 - 910	60
S37058001	Wa1	78
S37059001	Wa1	78
S37060001	Wa1	78
S37445000	W2 - 6-1-40	70
S37454000	D2 - 158	16
	D4 - 494-3	25
S37915009	A1 - 14	2
S37920009	A1 - 26	2
S37927000	B - 17	8
S37928019	B - 29	8
S37928021	B - 29	8
S37928419	Z - 32	74
S37932001	C1 - 1-5	10
S37933001	C1 - 1-6	10
	C1 - 6-3	10
S37934001	C1 - 4	10
S37936001	C1 - 6-1	10
S37937001	C1 - 19	10
S37939001	C1 - 22	10
S37940001	B - 28	8
	C1 - 25	10
S37941001	C1 - 20	10
S37942000	C1 - 27	10
S37943000	C1 - 28	10
S37944000	C1 - 29	10
S37946001	C1 - 34	10
S37947001	C1 - 36	10
S37978151	E - 5	30
S37981051	E - 9	30
S37983001	G1 - 6	36
S37984000	G1 - 17	36
	G1 - 45	36
S37985000	G1 - 23	36
S37986000	G1 - 24	36
S37987001	G1 - 28	36
S37988000	G1 - 29	36
S38001001	L - 1	44
S38002101	L - 3	44
S38003001	L - 8	44
S38004002	L - 10	44
S38004003	L - 10	44
S38004004	L - 10	44
S38005001	L - 15	44
S38006001	L - 21	44
S38007001	L - 21-1	44
S38008001	L - 25	44
S38009001	L - 25-1	44
S38010001	L - 29	44
S38011001	L - 34	44
S38016001	L - 44	44
S38144100	R2 - 13-1	62
S38145000	R1 - 79	58
S38146000	R2 - 13-2	62
S38151001	T - 1	64
S38154000	T - 1-1	64
S38155000	T - 1-2	64
S38164000	T - 1-3	64
S38274001	J - 1-8	40
S38351001	Wa1	77
S38352101	Wa1	77
S38353101	Wa1	77
S38355001	Wa1	77

CODE	REF.NO.	Page
S38357001	Wa1	77
S38357002	Wa1	77
S38571001	Wa1	77
S38571002	Wa1	77
S38819000	R1 - 4	56
S38820000	R1 - 5	56
S39113000	Q - 9	52
S39115000	Q - 20-2	52
	Q - 21-3	52
	W2 - 6-2	70
S39116000	Q - 20-3	52
	Q - 21-4	52
S39847001	K - 2-21	42
S39903001	K - 2-7	42
S39908000	K - 2-21-1	42
S40431000	R2 - 6	62
S40432000	R2 - 6-1	62
S40433000	R2 - 6-2	62
S40435000	R2 - 32	62
S40436000	R2 - 32-1	62
S40437000	R2 - 33	62
S40438001	P - 1	50
S40439001	P - 1-1	50
S40440001	P - 1-2	50
S40445009	P - 3	50
S40447000	P - 3-1	50
S40448000	P - 3-3	50
S40449001	R1 - 50-1	56
S40451009	P - 4	50
S40452009	P - 4-1	50
S40453000	P - 5	50
S40454000	P - 7	50
S40455000	P - 3-5	50
S40456000	R1 - 9	56
S40457000	R1 - 10	56
S40458000	R1 - 11	56
S40460000	R1 - 13	56
S40461000	R1 - 14	56
S40462000	R1 - 14-1	56
	R1 - 30-1	56
S40463000	R1 - 32	56
S40464000	R1 - 17	56
S40467000	R1 - 18	56
S40468000	R1 - 19	56
S40469000	R1 - 24	56
S40470000	R1 - 25	56
S40471000	R1 - 26	56
S40472000	R1 - 27	56
S40473000	R1 - 60-3	58
S40474000	R1 - 61	58
S40475000	R1 - 67	58
S40476000	R1 - 69	58
S40481000	R1 - 81	58
S40485001	R1 - 50	56
S40486000	R1 - 76	58
S40489101	T - 2	64
S40491001	R1 - 50-4	56
S40492001	R1 - 50-14	56
S40493001	R1 - 50-14-1	56
S40494000	R1 - 50-14-2	56
S40495001	R1 - 50-18	58
S40496000	W1 - 1-1-3	68
S40497000	R1 - 80	58

CODE	REF.NO.	Page
S40499009	P - 4-2	50
S40500000	R1 - 14-2	56
S40503000	R1 - 87	58
S40504000	P - 13	50
S40505000	P - 17	50
S40509000	R1 - 77	58
S40510000	R1 - 22	56
S40511001	P - 3-4	50
S40513009	R1 - 60	58
S40518000	D4 - 473	25
S40519000	W1 - 10-8	68
S40520009	W1 - 10	68
S40622000	R1 - 924	60
S40623000	R1 - 920	60
S40639001	Z - 17-8	72
S40641001	Z - 17-17	72
S40643001	Z - 17-18	72
S40644001	Z - 17-19	72
S41511001	D1 - 1	14
S41512001	D1 - 7	14
S41513001	D1 - 21	14
S41514001	D1 - 26	14
S41515001	D1 - 30	14
S41516001	D1 - 34	14
S41517000	D1 - 100	14
S41518101	D1 - 106	14
S41519001	D1 - 109	14
S41520001	D1 - 114	14
S41521000	D1 - 118	14
S41522000	D1 - 118-1	14
S41523000	D1 - 118-2	14
S41524000	D1 - 118-3	14
S41525001	D1 - 120	14
S41526001	D1 - 124	14
S41527001	D1 - 129	14
S41528001	D2 - 131	16
S41529001	D2 - 133	16
S41530001	D2 - 136	16
S41531001	D2 - 150	16
S41532001	D2 - 150-1	16
S41533000	D2 - 150-2	16
S41534000	D2 - 153	16
S41535000	D2 - 153-1	16
S41536001	D2 - 156	16
S41537000	D2 - 157	16
S41538000	D2 - 157-1	16
S41539001	D2 - 159	16
S41540000	D2 - 191	16
S41541001	D2 - 199	16
S41542001	D2 - 211	16
S41543100	D2 - 220	17
S41544001	D2 - 214	16
S41545201	D2 - 216	16
S41548100	D2 - 225	17
S41549100	D2 - 225-1	17
S41550100	D2 - 226	17
S41551001	D2 - 230	17
S41553000	D2 - 237	17
S41556101	D2 - 251	17
S41557001	D2 - 254	17
S41558001	D2 - 255	17
S41559000	D2 - 257	17
S41560001	D2 - 261	17

CODE	REF.NO.	Page
S41561001	D2 - 262	17
S41562009	D3 - 300	20
S41563109	D2 - 265	17
S41564201	D3 - 304	20
S41565101	D3 - 307	20
S41566101	D3 - 310	20
S41567001	D3 - 314	20
S41568000	D3 - 320	20
S41569000	D3 - 320-1	20
S41570001	D3 - 322	20
S41571001	D3 - 324	20
S41572001	D3 - 325	20
S41573001	D3 - 328	20
S41574001	D3 - 329	20
S41577001	D3 - 336	20
S41578001	D3 - 337	20
S41579001	D3 - 341	20
S41580001	D3 - 342	20
S41581000	H - 6	38
S41583001	D3 - 349	20
S41584001	D3 - 350	20
S41585101	D3 - 352	20
S41586101	D3 - 353	20
S41587001	D3 - 355	20
S41588001	D3 - 358	21
S41589001	D3 - 360	21
S41590001	D3 - 361	21
S41591001	D3 - 363	21
S41592001	D3 - 367	21
S41594001	D3 - 343	21
S41595001	D3 - 344	21
S41596201	D3 - 373-13	21
	D3 - 375	21
S41597001	D4 - 404	24
S41598000	D4 - 408	24
S41600000	D4 - 420	24
S41601101	D4 - 551	26
S41602000	D4 - 435	24
S41603101	D4 - 436	24
S41604101	D3 - 380	21
S41605101	Z - 20	74
	D3 - 381	21
S41606100	D4 - 442	24
S41609000	D4 - 494	25
S41610001	D4 - 495	25
S41611001	D4 - 497	25
S41612001	D4 - 502	25
S41613001	D4 - 514	25
S41615001	D4 - 522	26
S41621001	D4 - 400	24
S41626001	Z - 43	74
	D2 - 246-3	18
	D2 - 247-3	17
	D2 - 248-3	18
S41627001	Z - 44	74
	D2 - 246-4	18
	D2 - 247-4	17
S41628001	S - 15-1	62
S41629001	S - 15-2	62
S41630001	D2 - 200	16
S41631000	Q - 21	52
S41632000	Q - 20	52
S41633000	Q - 20-1	52

CODE	REF.NO.	Page
S41633000	Q - 21-1	52
S41634000	Q - 21-2	52
S41635000	C2 - 14	12
S41636000	Q - 55	52
S41637000	Q - 10	52
S41638001	W1 - 1-1-1	68
S41639001	W1 - 1	68
S41640001	W1 - 1-1	68
S41641000	Q - 1	52
S41669009	A1 - 18	2
S41670009	A1 - 21	2
S41671009	A1 - 21-1	2
S41672000	A1 - 21-2	2
S41673001	A1 - 85	2
	A2 - 85	6
S41674000	A1 - 85-2	2
S41675109	A1 - 15	2
S41677001	B - 1	8
S41678001	B - 3	8
S41679001	B - 14	8
S41680001	B - 14-1	8
S41683000	B - 19	8
S41684000	B - 21	8
S41685001	B - 23	8
S41686001	B - 24	8
S41687001	B - 25	8
S41688000	B - 30	8
S41689001	B - 33	8
S41691001	B - 36	8
S41692001	B - 37	8
S41693001	B - 38	8
S41694001	B - 39	8
S41695001	B - 40	8
S41696001	B - 14-6	8
S41697001	B - 34	8
S41698001	C1 - 1	10
S41699000	C1 - 1-1	10
S41700001	C1 - 2	10
S41701001	C1 - 6	10
S41702001	C1 - 6-6	10
S41703000	C1 - 11	10
S41704001	C1 - 12	10
S41705001	C1 - 14	10
S41706001	C1 - 31	10
S41707001	C1 - 37	10
S41709001	A1 - 85-1-2	2
S41710001	E - 8	30
S41712001	E - 19	30
	F - 47	32
S41713901	E - 101	30
	F - 101	34
S41714101	E - 100	30
	F - 100	34
S41715001	G1 - 18	36
	G1 - 46	36
S41716000	G1 - 50	36
S41717001	E - 14	30
S41718001	E - 14-2	30
	F - 42-2	32
S41719001	J - 1	40
S41721001	J - 1-1	40
S41722001	J - 1-2	40
S41723001	J - 1-3	40

CODE	REF.NO.	Page
S41724001	J - 1-4	40
S41725001	J - 1-7	40
S41726001	J - 1-16	40
S41727001	J - 1-17	40
S41728001	J - 1-22	40
S41729001	J - 6	40
S41730001	J - 10	40
S41731001	J - 14	40
S41732009	W1 - 8-3-1	68
S41733001	A1 - 85-1	2
S41734001	L - 18	44
S41735001	L - 40	44
S41737001	L - 43	44
S41738001	F - 77	34
	L - 49	46
S41739001	W1 - 8-3-2	68
S41740009	W1 - 8-3-3	68
S41741000	N - 1	48
S41742000	N - 2	48
S41743000	W1 - 8-3-4	68
S41744001	W1 - 8-3	68
S41745001	A2 - 1	4
S41746000	A2 - 5	4
S41747009	A2 - 7	4
S41748001	A2 - 8	4
S41749001	A2 - 11	4
S41750001	A2 - 13	4
S41751001	A2 - 15	4
S41752001	A2 - 18	4
S41753001	A2 - 19	4
S41754000	A2 - 22	4
S41757001	A2 - 26	4
S41758001	A2 - 28	4
S41759001	A2 - 30	4
S41760001	A2 - 32	4
S41761001	A2 - 36	4
S41762009	A2 - 40	4
S41763009	A1 - 45	2
S41764009	A1 - 46	2
S41765009	A2 - 48	4
S41767000	A2 - 50	4
S41768001	A2 - 54	4
S41769001	A2 - 55	4
S41770009	A2 - 71	6
S41771001	A2 - 72	6
S41772009	A2 - 78	6
S41773009	A2 - 78-1	6
S41774001	A2 - 81	6
S41776001	W1 - 8	68
S41777001	C2 - 1	12
S41778001	C2 - 1-1	12
S41780001	C2 - 1-2	12
S41782001	C2 - 1-3	12
S41783000	C2 - 1-4	12
S41784000	C2 - 1-5	12
S41785001	C2 - 4	12
S41786000	C2 - 6	12
S41787101	C2 - 7	12
S41789001	C2 - 7-1	12
S41791000	C2 - 7-6	12
S41792000	C2 - 7-7	12
S41794001	C2 - 7-8	12
S41796101	Ga - 10	76

CODE	REF.NO.	Page
S41801001	C2 - 8	12
S41802001	C2 - 20	12
S41803001	Z - 1	72
	Ga - 13	76
S41804001	C2 - 28	12
S41805001	F - 37	32
S41808000	F - 4	32
S41809000	F - 6	32
S41810001	F - 12	32
S41811000	F - 16	32
S41812001	F - 17	32
S41813001	F - 18	32
S41814000	F - 22	32
S41815001	F - 25	32
S41819001	F - 27	32
S41820001	F - 28	32
S41821001	F - 32	32
S41822001	F - 34	32
S41823001	F - 35	32
S41824001	F - 35-2	32
S41825001	F - 42	32
S41826001	F - 42-1	32
S41829001	F - 52	32
S41830001	F - 55	34
S41831001	F - 55-1	34
S41832001	F - 57	34
S41833001	F - 59	34
S41834000	F - 61	34
S41836001	F - 63	34
S41837000	F - 68	34
S41838001	F - 69	34
S41839001	F - 71	34
S41840001	F - 72	34
S41841109	F - 82	34
S41842000	F - 83	34
S41843009	F - 86	34
S41844009	F - 87-1	34
S41845000	F - 89	34
S41846001	F - 91	34
S41847009	F - 93	34
S41848000	F - 95	34
S41849000	F - 97	34
S41850001	F - 56	34
S41851001	K - 2-2	42
S41852000	G2 - 2	38
S41853001	G2 - 3	38
S41855001	G2 - 5	38
S41856000	G2 - 9	38
S41857001	G2 - 11	38
S41858009	K - 2-1	42
S41859009	K - 1	42
S41860009	K - 1-1	42
S41861000	K - 1-9	42
S41862000	K - 1-10	42
S41863009	K - 2	42
S41864009	K - 4	42
S41865001	H - 2	38
S41866001	H - 4	38
S41867000	H - 5	38
S41870001	H - 7	38
S41871001	H - 11	38
S41872001	H - 21	38
S41873001	H - 25	38

CODE	REF.NO.	Page
S41874000	M - 1	48
S41877001	M - 2	48
S41878001	M - 6	48
S41881000	U - 1	64
S41882001	U - 2	64
S41883009	U - 4	64
S41884001	U - 6	64
S41885009	V - 1	66
S41886009	V - 1	66
S41887009	V - 1-1	66
S41888009	V - 4	66
S41889001	R1 - 94	58
S41890009	V - 9	66
S41891001	V - 14	66
S41892009	V - 16	66
S41893001	V - 1-2	66
S41894001	V - 1-2	66
S41895001	V - 30	66
S41896000	V - 39	66
S41897000	V - 40	66
S41898009	V - 41	66
S41899009	V - 43-1	66
S41900009	V - 43-2	66
S41901009	Z - 2	72
S41903001	Z - 18	74
S41906001	W1 - 8-1	68
S41907001	W1 - 8-1-1	68
S41908001	W1 - 8-2	68
S41909000	V - 31	66
S41910009	V - 50	66
S41911101	D3 - 347	20
S41912001	D2 - 142	16
S41913100	D2 - 146	16
S41914000	D2 - 148	16
S41915001	D4 - 519	25
S41916000	Q - 72	54
S41919001	D5 - 570-6	28
S41925101	D4 - 449	24
S41926001	D4 - 456-2	24
S41927001	D4 - 456-3	24
S41928001	B - 16	8
S41935000	H - 17	38
	Q - 79	54
	C2 - 15	12
S41936000	H - 15	38
S41937000	Q - 80	54
S41938000	Q - 51	52
	Q - 52	52
	Q - 68	54
S41939000	Q - 53	52
	Q - 69	54
S41940000	Q - 66	54
	Q - 67	54
	A2 - 24	4
S41941000	Q - 62	52
	Q - 64	52
S41943000	F - 66	34
	H - 20	38
	Q - 58	52
	Q - 60	52
	Q - 63	52
	C2 - 32	12
S41959001	S - 15	62

CODE	REF.NO.	Page
S41960001	D1 - 17	14
S41961000	R1 - 14-3	56
S41963000	R1 - 14-4	56
S41964000	P - 19	50
	R1 - 35	56
S41965001	R1 - 89	58
S41967000	R1 - 23	56
S41969000	P - 18	50
S41972000	R1 - 21	56
S41975000	R2 - 1	62
S41976000	R2 - 2	62
S42227009	A1 - 29	2
S43402000	R1 - 30	56
S43611001	W2 - 6-1-1	70
S43612001	W2 - 6-1-3	70
S43613000	W2 - 6-1-4	70
	W2 - 6-1-13	70
S43614001	W2 - 6-1-12	70
S43615001	W2 - 6-1-15	70
S43616001	W2 - 6-1-18	70
S43617001	W2 - 6-1-22	70
S43618001	W2 - 6-1-29	70
S43619001	W2 - 6-1-26	70
S43620001	W2 - 6-1-30	70
S43621001	W2 - 6-1-37	70
S43622001	W2 - 6-1	70
S43623000	W2 - 6-1-2	70
S43624000	W2 - 6-1-2-1	70
S43625000	W2 - 6-1-8	70
S43627000	W2 - 6-1-8-1	70
S43628000	W2 - 6-1-8-2	70
S43629000	W2 - 6-1-9	70
S43630000	W2 - 6-1-9-1	70
S43631000	W2 - 6-1-9-2	70
S43632001	W2 - 6	70
S43634101	D2 - 270	17
S43636001	D2 - 221	17
S43640001	D1 - 24	14
	D1 - 33	14
S43958001	D2 - 239	17
S43959001	D2 - 246-1	18
S43960001	D2 - 247-1	17
S43961001	D2 - 248-1	18
S43963001	D3 - 373-10	21
S43965001	D3 - 373-11	21
S43966001	D3 - 373-12	21
S43967001	D3 - 373-6	21
S43968001	D3 - 373-7	21
S43969001	D3 - 373-1	21
S43970001	D3 - 373-2	21
S43997001	D4 - 510	25
S43998001	D4 - 521	26
S43999001	D4 - 529	26
S44000000	D4 - 533	26
S44209000	D3 - 348	20
S44210000	D3 - 348-1	20
S44688000	D1 - 22	14
	D1 - 31	14
S44762001	Ga - 11	76
S44763001	Ga - 12	76
S44773101	F - 98	34
S44775000	A2 - 91	6
S44822001	R1 - 72	58

CODE	REF.NO.	Page
S44823001	R1 - 71	58
S44831001	R1 - 72-1	58
S44832001	R1 - 71-1	58
S44957001	D2 - 246	18
S44958001	D2 - 247	17
S44959001	D2 - 248	18
S449610XX	Ga - 14	76
S449620XX	Ga - 15	76
S449630XX	Ga - 16	76
S44964000	D3 - 373-14	21
	D3 - 385	21
	D4 - 385	24
S44965000	D3 - 373-15	22
	D3 - 386	21
	D4 - 386	24
S44966001	D4 - 560	26
S44967001	D4 - 561	26
S44968001	Z - 45	74
S44969001	Z - 46	74
S44970001	Z - 47	74
S44971001	Z - 48	74
S44972001	D3 - 331	20
S44973001	D3 - 332	20
S44974001	D3 - 373	21
S44975000	D3 - 371	21
S44976000	D3 - 319	20
S44978001	D2 - 140	16
S44979000	D2 - 139	16
S44980001	D3 - 299	20
S44983001	D5 - 570-1	28
S44984001	D5 - 570-1-1	28
S44985001	D5 - 570-1-2	28
S44986001	D5 - 570-1-3	28
S44987001	D5 - 570-2	28
S44988001	D5 - 570-3	28
S44989001	D5 - 570-4	28
S44990001	D5 - 570-5	28
S45188001	Z - 56	74
	Ga - 9	76
S45721001	F - 87-2	34
S45730000	P - 5	50
S45731000	P - 5	50
S45732000	P - 5	50
S45733000	P - 5	50
S46476001	R1 - 15	56
	R1 - 31	56
	R1 - 33	56
S46502000	R1 - 120	60
S46563001	F - 96	34
S46740001	C2 - 34	12
S46833001	P - 3-2	50
S47058001	D5 - 570	28
S47369001	D4 - 487	25
S47393001	D4 - 484	25
S47394001	D4 - 485	25
S47395001	D4 - 506	25
S47398000	D4 - 491	25
S47399009	D4 - 480	25
S47528001	D5 - 570-7	28
S47529001	D5 - 570-8	28
S47553001	D5 - 570-9	28
S47554001	D5 - 570-10	28
U32744000	T - 1-5	64

CODE	REF.NO.	Page
0A4300605	R2 - 7	62
0A4301005	T - 1-6	64
0A5300605	P - 3-6	50
0A5301005	P - 3-7	50
0A5301405	R1 - 50-3	56
0A5400806	P - 2	50
	D2 - 193	16
	D2 - 266	17
	R1 - 36	56
0A5401006	Q - 26	52
	D1 - 130	14
	R1 - 88	58
	R2 - 5	62
0A5401605	R1 - 921	60
002301203	R1 - 28	56
004400814	D2 - 147	16
	D3 - 330	20
	D4 - 486	25
004401414	D4 - 490	25
008300604	K - 2-3	42
	A1 - 47	2
	R1 - 50-19	58
	R1 - 60-1	58
	W1 - 1-1-4	68
008400604	P - 6	50
	U - 5	64
	V - 13	66
	V - 17	66
	V - 42	66
	A2 - 49	4
	C2 - 5	12
	D4 - 539	26
	W2 - 6-1-31	70
012060636	U - 3	64
	A2 - 27	4
	A2 - 29	4
	A2 - 67	6
	D1 - 113	14
	D2 - 215	16
012400436	J - 1-28	40
	D2 - 213	16
	D2 - 240	17
	D2 - 246-2	18
	D2 - 246-5	18
	D2 - 247-2	17
	D2 - 247-5	17
	D2 - 248-2	18
	D2 - 248-5	18
	D3 - 354	20
	D3 - 359	21
	D3 - 362	21
	D4 - 421	24
	D4 - 424	24
	D4 - 432	24
	D4 - 434	24
012500536	F - 8	32
	F - 33	32
	F - 41	32
	F - 43	32
	D2 - 134	16
	D2 - 232	17
013660612	J - 1-24	40
013710512	F - 36-2	32

CODE	REF.NO.	Page
013719412	F - 19	32
014060622	D4 - 426	24
014060632	Z - 17-18-1	72
014300332	K - 2-8	42
014500522	W1 - 10-22	68
014680422	K - 2-11	42
	C1 - 6-9	10
	D4 - 441	24
014680622	E - 3	30
	L - 7-2	44
014760622	B - 15	8
	B - 31	8
	E - 7	30
	E - 10	30
	E - 15	30
	F - 21	32
	L - 33	44
	P - 12	50
	C1 - 1-4	10
	C1 - 1-7	10
	C1 - 6-4	10
	C1 - 6-10	10
	C1 - 10	10
	C1 - 13	10
	C1 - 21	10
	C1 - 30	10
014770622	B - 12	8
	E - 13-1	30
	L - 2	44
	L - 22	44
014780622	B - 4	8
017086006	A2 - 58	4
	D1 - 3	14
017501006	D2 - 252	17
018061036	V - 51	66
018061222	Q - 2	52
018061236	W2 - 6-1-38	70
018061436	D2 - 143	16
018061636	A2 - 14	4
	A2 - 20	4
	A2 - 37	4
	A2 - 68	6
	A2 - 73	6
	D1 - 121	14
	D1 - 125	14
018062036	A2 - 41	4
	D1 - 8	14
	D1 - 102	14
	D2 - 151	16
018062536	D3 - 302	20
	D4 - 402	24
018063022	D1 - 107-1	14
	D1 - 115-1	14
018063036	D1 - 27	14
	D1 - 35	14
	W1 - 8-3-6	68
018065022	W1 - 8-1-2	68
018065036	P - 11	50
018081236	P - 14	50
	W1 - 8-3-5	68
018081636	V - 44	66
018082036	V - 6	66
018300636	D4 - 474	25

CODE	REF.NO.	Page
018300822	D4 - 527	26
018301236	D4 - 475	25
	R1 - 68	58
018400636	F - 60	34
	F - 92	34
	S - 15-3	62
	C2 - 27	12
	D3 - 376	21
	R1 - 50-10	56
	W1 - 1-2	68
018400836	H - 22	38
	V - 10	66
	A2 - 82	6
	C2 - 7-9	12
	C2 - 31	12
	D2 - 271	17
	D3 - 316	20
	D3 - 317	20
	D3 - 323	20
	D3 - 338	20
	D3 - 345	20
	D3 - 364	21
	D3 - 368	21
	D3 - 373-3	21
	D3 - 373-8	21
	D3 - 373-16	22
	D3 - 382	21
	D3 - 387	21
	D4 - 387	24
	D4 - 437	24
	D4 - 467	25
	D4 - 503	25
	D4 - 562	26
	R1 - 95	58
	R1 - 98	58
018401036	H - 8	38
	H - 12	38
	C2 - 7-5	12
	C2 - 9	12
	C2 - 21	12
	D1 - 18	14
	D2 - 201	16
	D2 - 263	17
	D3 - 308	20
	D3 - 311	20
	D3 - 333	20
	D4 - 409	24
	D4 - 443	24
	D4 - 451	24
	D4 - 457	24
	D4 - 459	25
	D4 - 507	25
018401136	D4 - 511	25
018401222	U - 7	64
	R2 - 3	62
018401236	H - 26	38
	K - 2-4	42
	A2 - 74	6
	A2 - 92	6
	D4 - 553	26
	R1 - 91	58
	W2 - 6-1-19	70
	W2 - 6-1-23	70

CODE	REF.NO.	Page
018401422	D4 - 538	26
018401636	C2 - 7-2	12
	D2 - 258	17
018402036	R1 - 109	60
018402536	D2 - 227	17
018403036	A2 - 56	4
018404036	R1 - 50-5	56
018404532	C1 - 16	10
018500636	C2 - 3	12
018500836	C2 - 2	12
018501036	B - 22	8
	A2 - 16	4
	C2 - 1-7	12
018501236	A2 - 2	4
	A2 - 31	4
	D2 - 217	16
	D4 - 405	24
	W2 - 6-1-16	70
018501422	E - 20	30
	F - 48	32
018501436	M - 3	48
018501636	M - 7	48
	C2 - 1-6	12
	C2 - 17	12
	D4 - 481	25
	R1 - 70	58
018502036	D3 - 305	20
	R1 - 50-20	58
018503036	Q - 22	52
018503536	D4 - 492	25
018680522	A1 - 17	2
018680822	B - 41	8
018681022	L - 11	44
018681232	B - 27	8
021060206	P - 23	50
	A2 - 6	4
	A2 - 90	6
021080206	A2 - 61	4
	D1 - 6	14
	D1 - 16	14
	D1 - 39	14
021160303	V - 1-5	66
021200203	V - 1-3	66
021300103	D4 - 478	25
	W1 - 10-5	68
	W2 - 6-1-36	70
021300206	Q - 82	54
	S - 15-10	62
	R1 - 29	56
021300303	R1 - 50-14-4	56
021400106	R1 - 923	60
021400202	D4 - 448	24
	W1 - 10-20	68
021400206	R1 - 3	56
	R1 - 110	60
021400216	R1 - 50-7	56
	R1 - 50-11	56
021400316	D3 - 321	20
021500102	D4 - 516	25
021500106	Q - 33	52
	Z - 17-10-3	72
	Z - 17-17-1	72
	Z - 17-18-2	72

CODE	REF.NO.	Page
021500106	Z - 17-19-1	72
021500216	D2 - 160	16
	D2 - 224	17
021680202	J - 15	40
	K - 1-7	42
022120306	V - 48-3	66
	V - 49	66
025030233	W1 - 10-3	68
	W1 - 10-16	68
	W2 - 6-1-34	70
025030236	K - 2-24	42
	S - 15-9	62
	D4 - 477	25
025030335	F - 42-10	32
025040136	C2 - 23	12
025040233	W1 - 10-13	68
025040236	H - 10	38
	H - 14	38
	H - 24	38
	H - 28	38
	S - 15-5	62
	V - 11	66
	A2 - 35	4
	A2 - 75	6
	A2 - 83	6
	C2 - 7-4	12
	C2 - 11	12
	C2 - 29	12
	D1 - 20	14
	D2 - 138	16
	D2 - 198	16
	D2 - 260	17
	D2 - 268	17
	D2 - 273	17
	D3 - 335	20
	D3 - 340	20
	D3 - 366	21
	D3 - 370	21
	D3 - 373-5	21
	D3 - 373-18	22
	D3 - 384	21
	D3 - 389	21
	D4 - 389	24
	D4 - 445	24
	D4 - 453	24
	D4 - 461	25
	D4 - 469	25
	D4 - 471	25
	D4 - 509	25
	D4 - 513	25
	D4 - 555	26
	D4 - 564	26
	R1 - 50-8	56
	R1 - 93	58
	R1 - 97	58
	R1 - 100	58
	R1 - 922	60
	W2 - 6-1-21	70
	W2 - 6-1-25	70
025050236	M - 5	48
	Q - 31	52
	A2 - 4	4
	C2 - 19	12

CODE	REF.NO.	Page
025050236	D4 - 407	24
	D4 - 483	25
	R1 - 50-21	58
025060232	Q - 4	52
	W1 - 12	68
025060236	V - 52	66
	A2 - 43	4
	A2 - 70	6
	D1 - 123	14
	D2 - 145	16
	D3 - 298	20
025060336	P - 21	50
025080236	P - 16	50
	V - 7	66
	V - 45	66
025100132	A2 - 65	6
025100236	D1 - 119	14
025350236	D4 - 524	26
	R1 - 65	58
025680132	L - 12	44
025680232	K - 1-13	42
	L - 39	44
	G1 - 8	36
026040136	D4 - 439	24
026050136	D2 - 219	17
	D2 - 223	17
028030242	D4 - 528	26
028030243	W1 - 10-4	68
	W1 - 10-10	68
	W1 - 10-17	68
	W2 - 6-1-35	70
028030246	S - 15-8	62
	D2 - 190	16
	D4 - 456-5	24
	D4 - 476	25
	D5 - 570-1-5	28
028040242	C2 - 22	12
028040246	H - 9	38
	H - 13	38
	H - 23	38
	H - 27	38
	S - 15-4	62
	V - 12	66
	A2 - 34	4
	A2 - 84	6
	A2 - 87	6
	C2 - 7-3	12
	C2 - 7-14	12
	C2 - 10	12
	C2 - 26	12
	C2 - 30	12
	D1 - 19	14
	D2 - 202	16
	D2 - 210	16
	D2 - 259	17
	D2 - 264	17
	D2 - 267	17
	D2 - 272	17
	D3 - 309	20
	D3 - 312	20
	D3 - 318	20
	D3 - 327	20
	D3 - 334	20

CODE	REF.NO.	Page
028040246	D3 - 339	20
	D3 - 346	20
	D3 - 357	21
	D3 - 365	21
	D3 - 369	21
	D3 - 373-4	21
	D3 - 373-9	21
	D3 - 373-17	22
	D3 - 377	21
	D3 - 383	21
	D3 - 388	21
	D4 - 388	24
	D4 - 438	24
	D4 - 444	24
	D4 - 452	24
	D4 - 460	25
	D4 - 468	25
	D4 - 508	25
	D4 - 512	25
	D4 - 554	26
	D4 - 563	26
	R1 - 92	58
	R1 - 96	58
	R1 - 99	58
	W1 - 1-3	68
	W2 - 6-1-7	70
	W2 - 6-1-11	70
	W2 - 6-1-20	70
	W2 - 6-1-24	70
028050246	F - 65	34
	M - 4	48
	Q - 23	52
	Q - 32	52
	Z - 17-10-2	72
	A2 - 3	4
	C2 - 18	12
	D2 - 161	16
	D2 - 162	16
	D2 - 218	16
	D2 - 222	17
	D2 - 253	17
	D3 - 306	20
	D4 - 406	24
	D4 - 482	25
	W2 - 6-1-17	70
028060242	Q - 3	52
028060246	P - 22	50
	V - 53	66
	A2 - 42	4
	A2 - 69	6
	D1 - 11	14
	D1 - 28	14
	D1 - 37	14
	D1 - 103	14
	D1 - 122	14
	D1 - 126	14
	D2 - 144	16
	D2 - 152	16
	D3 - 303	20
	D4 - 403	24
	W2 - 6-1-39	70
028080246	P - 15	50
	V - 8	66

CODE	REF.NO.	Page
028080246	V -46	66
	A2 -60	4
	D1 -4	14
028260242	K -2-29	42
028350242	L -21-6	44
028350243	F -42-9	32
028680242	F -55-4	34
	G1 -9	36
031452206	Z -17-2-2	72
	Z -17-19-2	74
037301215	A2 -78-3	6
039411215	V -27	66
047301042	K -2-18	42
048020342	W1 -10-7	68
048030346	D4 -472	25
048040342	C1 -6-7	10
048050142	D2 -212	16
	D4 -496	25
	D4 -498	25
048060342	L -32	44
	C1 -23	10
048070342	L -19	44
048080342	E -18	30
	F -46	32
	A2 -64	4
048100142	F -13	32
048120142	D2 -238	17
048130242	D4 -427	24
048150142	B -7	8
	D1 -110	14
048180142	C1 -8	10
048260242	F -3	32
	F -9	32
048320242	D1 -105	14
052300606	K -2-30	42
	D4 -557	26
052400606	R1 -111	60
052400806	R1 -53	58
	R1 -55	58
	R1 -57	58
	W1 -10-19	68
052401605	R1 -112	60
060300416	F -88	34
060300516	D4 -456-4	24
	D5 -570-1-4	28
060300612	F -90	34
	R1 -50-13	56
060350812	J -1-19	40
060400616	D2 -150-3	16
060400816	D2 -132	16
	D2 -137	16
	D3 -326	20
	D4 -537	26
060660512	K -2-16	42
060670512	G1 -16	36
060670612	J -9	40
	J -11	40
060680712	L -4	44
061300616	W2 -6-1-5	70
	W2 -6-1-14	70
062060806	Z -17-2-1	72
062300502	D2 -195	16
062300512	N -3	48

CODE	REF.NO.	Page
062300512	C1 -35	10
062300616	K -2-23	42
	A2 -80	6
	W1 -10-9	68
	W1 -10-15	68
062300806	R1 -34	56
	R2 -34	62
062301005	R1 -50-14-3	56
062301006	S -15-7	62
	R1 -16	56
062302016	W2 -6-1-33	70
062302506	Q -81	54
062400616	A2 -53	4
	W1 -10-12	68
062400816	D4 -455	24
062401012	A1 -22	2
062401016	A2 -33	4
	D2 -197	16
	W2 -6-1-6	70
062401416	W2 -6-1-10	70
062501006	V -1-7	66
	Z -17-19-3	74
062501406	Z -17-17-4	72
062660412	E -14-3	30
	F -42-3	32
062660712	E -14-7	30
	F -42-7	32
062670512	J -1-18	40
	G1 -27	36
	G1 -39	36
	G2 -8	38
	R2 -12	62
062670612	B -18	8
	J -17	40
	R1 -64	58
062671412	J -8	40
062680612	A1 -27	2
	C1 -3	10
	C1 -38	10
	G1 -7	36
	G1 -30	36
062680812	B -14-6-1	8
	B -34-1	8
	N -4	48
062681012	C1 -26	10
062681212	J -5	40
	K -1-12	42
062682012	J -4	40
062710812	R1 -62	58
062711212	A1 -20	2
062761212	W1 -11	68
062781412	B -20	8
070688850	C1 -15	10
	C1 -24	10
072512260	F -15	32
072600080	F -5	32
	F -11	32
072630260	B -6	8
076002800	D1 -104	14
076805800	D4 -488	25
081003670	E -12	30
	E -17	30
	F -40	32

CODE	REF.NO.	Page
081003670	F -45	32
100022004	K -1-11	42
100022005	L -24	44
	L -25-3	44
	W1 -13	68
100032004	F -79	34
	L -51	46
	C1 -33	10
100090004	E -2	30
100136001	K -1-3	42
100250001	B -11	8
100257010	A1 -85-3	2
	D4 -525	26
100360003	F -81	34
	L -54	46
100402004	D4 -465	25
100645003	C1 -39	10
100887001	Z -8	72
101482001	B -32	8
101572101	Z -40	74
101706001	B -13	8
	E -6-1	30
	C1 -5-2	10
102707002	C2 -7-11	12
	C2 -7-15	12
	R1 -50-9	56
104449009	A1 -12	2
104450109	K -3	42
	A1 -3	2
	A1 -11	2
	A2 -44	4
104567001	G1 -21	36
104821009	A2 -57	4
104833009	A2 -39	4
105161004	D4 -456-6	24
105234003	F -55-3	34
105288001	D4 -520	26
105299002	A2 -10	4
106129002	L -21-5	44
	A1 -85-1-5	2
	A1 -85-4	2
106147002	L -14	44
106588003	R1 -50-23	58
106629002	F -70	34
	F -84	34
	F -94	34
	K -5	42
	A1 -16	2
	G2 -10	38
107017002	P -4-4	50
	W2 -6-1-28	70
107149001	G1 -5	36
	G1 -13	36
107321003	P -4-3	50
107657001	F -58	34
107779001	Z -6	72
107780001	Z -9	72
108265009	J -1-6	40
109893002	J -1-27	40
	L -28	44
110161004	L -27	44
	L -37	44
110233001	L -26	44

CODE	REF.NO.	Page
110233001	L - 36	44
110367001	L - 31	44
	D2 - 231	17
110735002	B - 42	8
	K - 2-5	42
111140002	F - 78	34
	L - 50	46
111942001	K - 2-14	42
111943001	K - 2-15	42
112712001	J - 1-9	40
114483002	Z - 3	72
114486002	A2 - 79	6
115127001	F - 36-1	32
115157001	Z - 60	74
116662004	D2 - 154	16
116920001	D1 - 111	14
117150001	R2 - 11	62
117936009	D3 - 372	21
118064001	Z - 13	72
118550001	D1 - 2	14
	D1 - 25	14
118837001	Z - 39	74
120192000	Z - 16	72
120438001	E - 21	30
	F - 2	32
121007001	L - 42	44
122257001	F - 29	32
122991001	Z - 15	72
126863001	Z - 17-5	72
132051001	B - 14-4	8
133172003	V - 1-6	66
138843001	Z - 17-12	72
140392009	P - 25	50
	A1 - 6	2
	A1 - 13	2
140647001	G2 - 6	38
140682001	Q - 20-5	52
	Q - 21-6	52
140726000	B - 5	8
140947002	D4 - 447	24
141542001	D4 - 534	26
141590001	K - 1-8	42
141786001	E - 1	30
142002001	Z - 10	72
142205001	Z - 7	72
142721001	Z - 12	72
142990001	Z - 17-15-3	72
142997001	Z - 17-7	72
144105000	J - 1-25	40
	K - 1-6	42
144110001	J - 1-26	40
	K - 1-4	42
144458001	B - 43	8
144504001	W1 - 10-21-3	68
144712001	B - 2-1	8
145318001	C1 - 32	10
145446001	J - 1-12	40
	K - 1-5	42
145478101	L - 9	44
145547001	G1 - 26	36
145624000	G2 - 14	38
146124001	J - 1-5	40
146197001	K - 2-20	42

CODE	REF.NO.	Page
146354001	U - 8	64
148239001	F - 54	32
148417001	D4 - 518	25
148738000	G1 - 4	36
	G1 - 40	36
	G1 - 41	36
148813001	L - 21-4	44
148851001	J - 1-15	40
149547000	R1 - 51	58
149566109	J - 1-14	40
149796001	Z - 5	72
149809000	R1 - 926	60
149864051	D4 - 464	25
149996001	A2 - 9	4
150172003	Z - 17-8-1	72
	Z - 17-16	72
150173003	Z - 17-9	72
150179002	Z - 17-10-1	72
150180001	Z - 17-3	72
150182000	Z - 17-4	72
150183000	Z - 17-15-2	72
150185009	Z - 17-11	72
150188009	Z - 17-13	72
150189109	Z - 17-1	72
150335001	Z - 14	72
150349001	R1 - 117	60
150357001	P - 24	50
150594001	F - 20	32
151602002	F - 30	32
151927001	G1 - 20	36
152231000	B - 10	8
152236001	B - 14-2	8
152237001	B - 14-3	8
152238001	B - 14-5	8
152245001	E - 4	30
152361001	K - 2-12	42
152362001	K - 2-13	42
152363001	K - 2-17	42
152364001	K - 2-19	42
152393200	V - 1-4	66
152507000	K - 2-21-2	42
152508000	K - 2-21-3	42
152509000	K - 2-21-4	42
152510000	P - 26	50
	R1 - 7	56
152566000	P - 1-1-2	50
	P - 1-2-3	50
	Z - 51	74
152645001	K - 2-22	42
152678001	E - 11	30
	E - 16	30
	F - 39	32
	F - 44	32
152683001	E - 14-4	30
	F - 42-4	32
152684101	E - 14-5	30
	F - 42-5	32
152743001	C1 - 1-2	10
	C1 - 6-2	10
	C1 - 6-5	10
152756001	C1 - 9	10
152760051	C1 - 7	10
152863001	R1 - 50-22	58

CODE	REF.NO.	Page
152889001	J - 16	40
152948001	G1 - 1	36
	G1 - 32	36
	G2 - 1	38
152956001	G1 - 42	36
152960001	G1 - 52	36
152962001	G1 - 51	36
152969001	G1 - 38	36
153040001	B - 2	8
153050000	E - 14-8	30
	F - 42-8	32
153113001	R1 - 50-16	58
153208002	F - 85	34
153215001	J - 7	40
153218001	D2 - 155	16
153242000	P - 1-2-1	50
	Z - 52	74
153252000	Q - 1-3	52
153484001	L - 38	44
153562001	G1 - 19	36
	G2 - 13	38
153596001	F - 31	32
	F - 53	32
153597001	L - 21-2	44
153769001	V - 48-2	66
153920001	G1 - 12	36
	G1 - 37	36
154024001	K - 2-9	42
154092001	K - 2-10	42
154125001	Z - 11	72
154467001	A2 - 78-2	6
154514001	D4 - 489	25
	R1 - 50-6	56
154560001	W1 - 10-21-4	68
154590001	F - 55-2	34
154596000	L - 20	44
154599000	L - 5	44
154627001	B - 26	8
154702101	Z - 4	72
154760001	Z - 38	74
155103001	D3 - 356	21
156956001	C1 - 1-3	10
156958001	D1 - 101	14
	D3 - 301	20
	D4 - 401	24
157219000	P - 1-2-2	50
	Z - 53	74
157270101	R1 - 101	58
158597001	K - 2-25	42
158722002	D3 - 313	20
	D3 - 378	21
158769001	J - 1-11	40
158830001	A2 - 62	4
158831001	A2 - 63	4
158832009	A2 - 66	6
158940001	L - 35	44
159114001	D4 - 446	24
159150009	V - 5	66
159574101	K - 1-2	42
159805001	J - 1-13	40
159905001	L - 13	44
159928009	A1 - 4	2
	A2 - 76	6

CODE	REF.NO.	Page
181995001	E - 6	30
183377001	W1 - 10-21	68
183493001	C1 - 5	10
213650001	A2 - 59	4
	D1 - 5	14
215769001	P - 1-1-1	50
	Z - 50	74
228475000	F - 62	34
	L - 55	46
	G1 - 44	36
	G2 - 15	38
	R1 - 115	60
231071001	L - 16	44
402887001	E - 14-6	30
	F - 42-6	32
525567000	R1 - 54	58
552851001	K - 2-21-5	42
554482000	Q - 25	52
	R1 - 56	58
625010000	A2 - 52	4
	R1 - 37	56

brother®

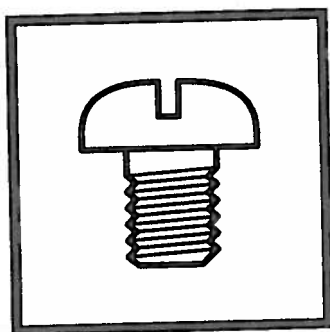

パーツブック
PARTS BOOK
TEILEKATALOG
LIVRE DES PIECES
LIBRO DE REFERENCIA DE PIEZAS

ブラザー工業株式会社

〒467-8561 名古屋市瑞穂区苗代町15番1号 TEL(052)824-2392

BROTHER INDUSTRIES, LTD.

15-1, Naeshiro-cho, Mizuho-ku, Nagoya 467-8561, Japan. Phone: 81-52-824-2177

Printed in Japan / Gedruckt in Japan / Imprimé au Japon / Impreso en Japón

151-705
S98705-201
2002.04. B (1)