

brother

BAS-752·750L 754·750KL

電子ポケットセッター<BAS-752>
電子ポケットセッター (ニット用) <BAS-754>

AUTOMATIC POCKET SETTER <BAS-750L>
AUTOMATIC POCKET SETTER (KNIT WEAR) <BAS-750KL>

COMPUTERGESTEUERTER TASCHENAUFNÄHAUTOMAT <BAS-750L>
COMPUTERGESTEUERTER TASCHENAUFNÄHAUTOMAT FÜR STRICKWAREN
<BAS-750KL>

AUTOMATE POUR PLACAGE DE POCHE <BAS-750L>
AUTOMATE POUR PLACAGE DE POCHE (POUR TRICOT) <BAS-750KL>

AUTOMATA DE BOLSILLOS <BAS-750L>
AUTOMATA DE BOLSILLOS (PARA PUNTO) <BAS-750KL>

PICK	021100501	QUANTITY	1
ORDER: 338324		EA	
PART: 185752001		BATCH: 11	
PARTS CODE: BA3752-750L-754			

brother We're at your side.

NCIA DE PIEZAS

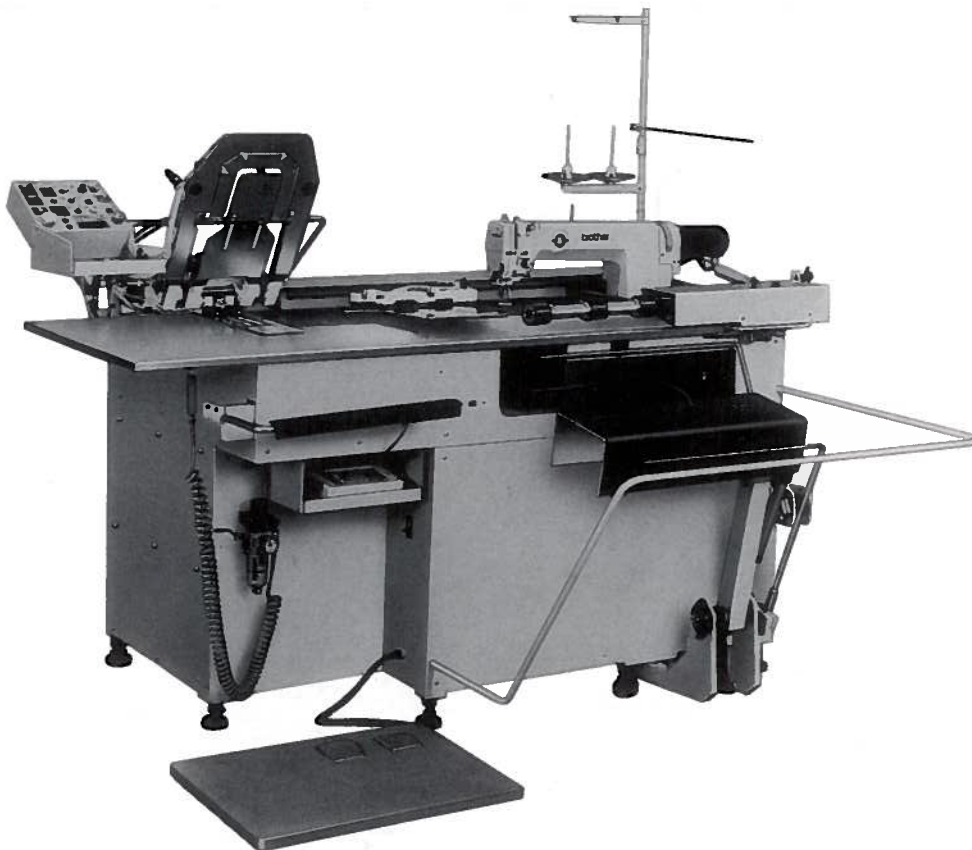

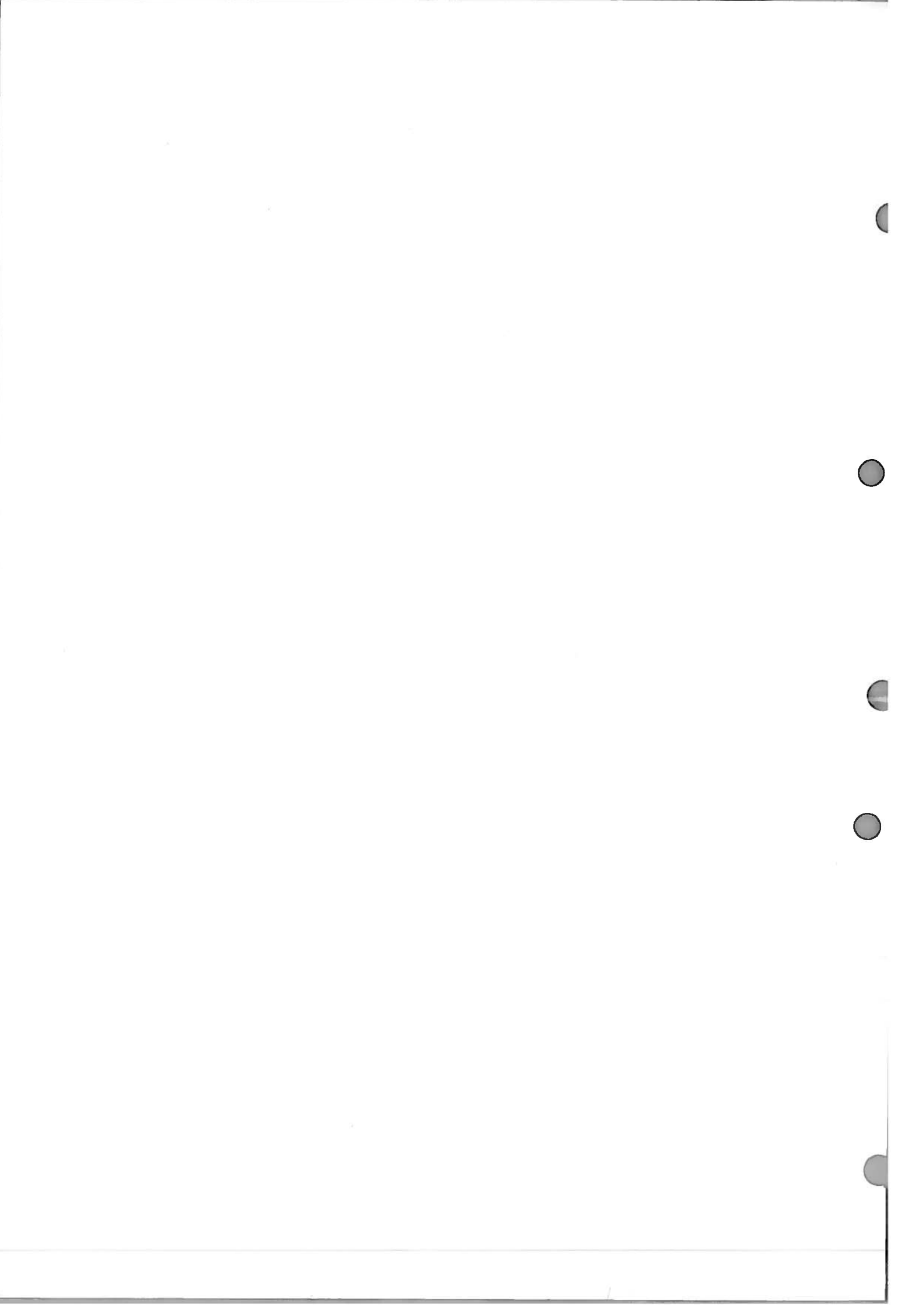

パーツブックご利用に際して

1. 組単位で補給する部品は、 破線で示しております。
2. この本は1992年7月のデータに基づいて作成されたものです。
3. 部品は予告なしに設計変更される場合があります。
4. 部品コード欄が*となっている場合は、仕様別部品一覧表(105~108ページ)でお調べ下さい。

目 次

A. 主体関係	2
B. 針棒・天ピン関係	4
C. 針板関係	6
D. 押エ関係	8
E 1 ~ E 3. スタッカ関係	10~18
F. 駆動側・送り関係	20
G. 送り案内関係	24
H 1. ボトム関係<BAS-752>	26
H 2. ボトム関係<BAS-754>	26
J 1 ~ J 4. 折曲ゲ関係 (特別注文部品)	28~50
K 1 ~ K 2. 折曲ゲ土台関係	52~54
L. カマ関係	56
M. 糸切れ感知関係	58
N 1 ~ N 2. 給油潤滑関係	58~60
P. 糸通シ関係	62
Q. 糸巻き関係	64
R. 糸切り関係	66
S. 糸ユルメ関係	68
T. 踏板関係	68
U 1 ~ U 2. 空圧関係	70~74
V 1 ~ V 2. 電装品関係	76~80
W 1. マーカー関係<BAS-752>	84
W 2. マーカー関係<BAS-754>	86
X. プリント基板関係	88
Y. モータ関係	88
Z 1. 動力台関係<BAS-752>	90
Z 2. 動力台関係<BAS-754>	94
A A. 付属装置関係	98
A B. 付属装置関係	100
A C. 付属品関係	102
仕様別一覧表	105~108
索引	109~125

Notes for using this parts book

1. Parts supplied as complete assemblies are circled by a dotted line  .
2. This book was prepared based on information available in July 1992.
3. Parts are subject to changes in design without prior notice.
4. If the symbol * is found in the "Parts No." column, refer to the parts list on page 105 ~ 108.

CONTENTS

A. Machine body	2
B. Needle bar and thread take-up mechanism	4
C. Needle plate mechanism	6
D. Presser foot mechanism	8
E1 ~ E3. Stacker mechanism	10 ~ 18
F. Drive, feed mechanism	20
G. Feed guide mechanism	24
H1. Bottom mechanism <BAS-750L>	26
H2. Bottom mechanism <BAS-750KL>	26
J1 ~ J4. Folding margin mechanism (OPTION PARTS)	28 ~ 50
K1 ~ K2. Folding margin base mechanism	52 ~ 54
L. Rotary hook mechanism	56
M. Thread breakage detector mechanism	58
N1 ~ N2. Lubrication	58 ~ 60
P. Threading mechanism	62
Q. Bobbin winder mechanism	64
R. Thread trimmer mechanism	66
S. Tension release mechanism	68
T. Foot switch pedal mechanism	68
U1 ~ U2. Air pressure mechanism	70 ~ 74
V1 ~ V2. Power supply equipment mechanism	76 ~ 80
W1. Marker mechanism <BAS-750L>	84
W2. Marker mechanism <BAS-750KL>	86
X. Printed circuit boards mechanism	88
Y. Motor mechanism	88
Z1. Power table <BAS-750L>	90
Z2. Power table <BAS-750KL>	94
AA. Attachment set	98
AB. Attachment set	100
AC. Accessories	102
DIFFERENT PARTS LIST	105 ~ 108
INDEX	109 ~ 125

Hinweise zur Verwendung dieser Teileiste

1. Die Teile, die als kompletter Satz geliefert werden, sind mit einer  gestrichelten Linie umrandet.
2. Dieses Buch basiert auf den Informationen vom Juli 1992.
3. Modelländerungen sind vorbehalten.
4. Dieses Zeichen * in der Spalte "Parts No. (Teilnummer)" verweist auf die Teileliste auf Seite 105 ~ 108.

INHALTSVERZEICHNIS

A. Maschinengehäuse	2
B. Nadelstangen und Fadenabnahmevorrichtung	4
C. Stichplattenmechanismus	6
D. Stoffdrückerfuß	8
E1 ~ E3. Anhäufung	10 ~ 18
F. Transportvorrichtung	20
G. Transportführung	24
H1. Unterer Mechanismus <BAS-750L>	26
H2. Unterer Mechanismus <BAS-750KL>	26
J1 ~ J4. Faltungsvorrichtung (SONDERZUBEHÖR)	28 ~ 50
K1 ~ K2. Faltungsvorrichtungsgrundplatte	52 ~ 54
L. Greifervorrichtung	56
M. Fadenbruchfühler	58
N1 ~ N2. Schmierung	58 ~ 60
P. Fadenführungsvorrichtung	62
Q. Spuler	64
R. Fadenabschneidevorrichtung	66
S. Spannungsverminderungsvorrichtung	68
T. Fußbetätigung	68
U1 ~ U2. Luftdruck	70 ~ 74
V1 ~ V2. Stromversorgung	76 ~ 80
W1. Markierungsvorrichtung <BAS-750L>	84
W2. Markierungsvorrichtung <BAS-750KL>	86
X. Leiterplatten	88
Y. Motor	88
Z1. Motorgestell <BAS-750L>	90
Z2. Motorgestell <BAS-750KL>	94
AA. Anbausatz	98
AB. Anbausatz	100
AC. Zubehör	102
ZUBEHÖRLISTE	105 ~ 108
VERZEICHNIS	109 ~ 125

Notes sur l'utilisation de ce manuel de pièces détachées



1. Les pièces fournies en tant qu'assemblages complets sont encadrées avec un trait pointillé  .
2. Ce manuel a été fait d'après les renseignements valables au mois de Juillet 1992.
3. Les pièces peuvent être sujettes à des modifications sans préavis.
4. Si le symbole * se trouve dans la colonne "Parts No. (N° de pièce)" veuillez la vous référer à la liste de pièces page 105 ~ 108.

TABLE DES MATIERES

A. Corps de la machine	2
B. Mécanisme de la barre à aiguille et releveur de fil	4
C. Mécanisme de plaque à aiguille	6
D. Mécanisme du pied presseur	8
E1 ~ E3. Mécanisme de l'empileur	10 ~ 18
F. Mécanisme d'alimentation, entraînement	20
G. Mécanisme du guide de l'entraînement	24
H1. Mécanisme inférieur <BAS-750L>	26
H2. Mécanisme inférieur <BAS-750KL>	26
J1 ~ J4. Mécanisme de marge d'ourlet (PIÈCES EN OPTION)	28 ~ 50
K1 ~ K2. Mécanisme de base de marge d'ourlet	52 ~ 54
L. Mécanisme du crochet rotatif	56
M. Mécanisme du détecteur de cassure du fil	58
N1 ~ N2. Lubrification	58 ~ 60
P. Mécanisme de l'enfilage	62
Q. Mécanisme du bobineur	64
R. Mécanisme de coupe-fil	66
S. Mécanisme de la lâche de tension	68
T. Mécanisme de la pédale	68
U1 ~ U2. Mécanisme de la pression d'air	70 ~ 74
V1 ~ V2. Mécanisme de l'équipement en alimentation électrique	76 ~ 80
W1. Mécanisme du marqueur <BAS-750L>	84
W2. Mécanisme du marqueur <BAS-750KL>	86
X. Circuits imprimés	88
Y. Mécanisme du moteur	88
Z1. Mécanisme du plateau de la machine <BAS-750L>	90
Z2. Mécanisme du plateau de la machine <BAS-750KL>	94
AA. Jeu d'accessoires	98
AB. Jeu d'accessoires	100
AC. Accessoires	102
LISTE DES PIÈCES ACCESSOIRES	105 ~ 108
INDEX	109 ~ 125

Notas para usar este Manual de Piezas

1. Las piezas suministradas como conjuntos completos se enmarcan con una línea punteada  .
2. Este libro ha sido compilado basándose en los datos de que se disponía en julio 1992.
3. Las piezas quedan sujetas a cambios de diseño sin aviso previo.
4. De haber un símbolo * junto al "Parts No. (Número de Pieza)", habrá que mirar la lista de piezas de la página 105 ~ 108.

INDICE

A. Cuerpo de la máquina	2
B. Mecanismo de la barra de aguja y tirahilos	4
C. Mecanismo de la placa de aguja	6
D. Mecanismo del prensatelas	8
E1 ~ E3. Mecanismo de apilador	10 ~ 18
F. Mecanismo de la alimentación, mando	20
G. Mecanismo de la guía de alimentación	24
H1. Mecanismo del fondo <BAS-750L>	26
H2. Mecanismo del fondo <BAS-750KL>	26
J1 ~ J4. Mecanismo de margen de plegado (PIEZAS A OPCION)	28 ~ 50
K1 ~ K2. Mecanismo base de margen de plegado	52 ~ 54
L. Mecanismo del cangrejo	56
M. Mecanismo del sensor de cortes de hilo	58
N1 ~ N2. Lubricación	58 ~ 60
P. Mecanismo del enhebrado	62
Q. Mecanismo del devanador de la canilla	64
R. Mecanismo de la cortadura de hilos	66
S. Mecanismo relajador de tensión	68
T. Mecanismo del pedal	68
U1 ~ U2. Mecanismo de la presión de aire	70 ~ 74
V1 ~ V2. Mecanismo del equipo de alimentación de corriente	76 ~ 80
W1. Mecanismo del marcador <BAS-750L>	84
W2. Mecanismo del marcador <BAS-750KL>	86
X. Tableros de circuitos impresos	88
Y. Mecanismo del motor	88
Z1. Mecanismo de la mesa de la máquina <BAS-750L>	90
Z2. Mecanismo de la mesa de la máquina <BAS-750KL>	94
AA. Juego de fijación	98
AB. Juego de fijación	100
AC. Accesorios	102
LISTA DE PIEZAS ACCESORIAS	105 ~ 108
INDICE	109 ~ 125

A. 主体関係 / Machine body / Maschinengehäuse /
 Corps de la machine / Cuerpo de la máquina

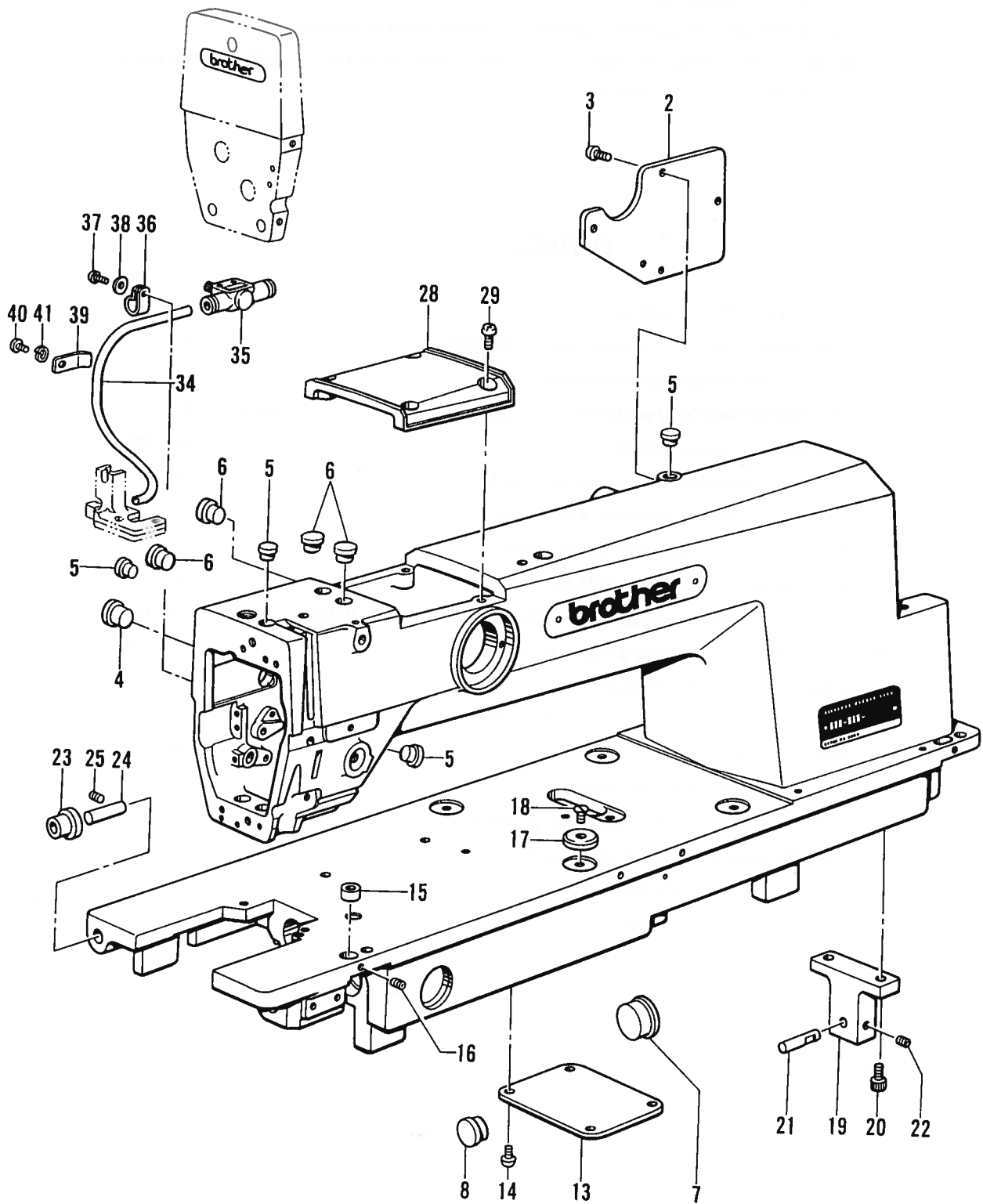

A. 主体関係 / Machine body / Maschinengehäuse /
Corps de la machine / Cuerpo de la máquina

REF NO.	CODE	Q'TY	ヒンメイ	NAME OF PARTS	RMKS
2	S11854009	1	ガ"ワイタ	REAR COVER	
3	062401012	4	ナヘ"コM4X10	SCREW M4X10	
4	104449009	1	メクラセン	OIL CAP	
5	104450109	4	メクラセン	OIL CAP	
6	104821009	4	メクラセン	OIL CAP	
7	147251009	1	メクラセン	OIL CAP	
8	150756009	1	メクラセン	OIL CAP	
13	S11855001	1	ソコフタ	BOTTOM LID	
14	062401012	4	ナヘ"コM4X10	SCREW M4X10	
15	S11856001	2	イチキ"メタル	POSITIONING BUSH	
16	014400422	2	アナトメネシ"4X4クホ"ミ	SET SCREW 4X4	
17	S11857000	4	ハリイタウケ	NEEDLE PLATE SUPPORT	
18	107272002	4	サラネシ"4.37	SCREW 4.37	
19	S11858001	1	トウフ"ササエタ"イ	HEAD SUPPORT STUD	
20	018501622	2	アナホ"ルト5X16	BOLT 5X16	
21	152866001	1	トウフ"ササエピン	PIN	
22	014500522	1	アナトメネシ"5クホ"ミ	SET SCREW 5	
23	152868009	2	ヘ"ット"ヒンジ"クッション	HINGE CUSHION	
24	152867000	2	ヘ"ット"ヒンジ"シ"ク	HINGE SHAFT	
25	014500522	2	アナトメネシ"5クホ"ミ	SET SCREW 5	
28	S11860009	1	ウフフ"タ	UPPER LID	
29	062401012	4	ナヘ"コM4X10	SCREW M4X10	
34	S19080000	1	エアホース4X2.5	AIR TUBE 4X2.5	
35	S09197000	1	スピード"コントローラ	SPEED CONTROLLER	
36	525664000	1	コード"ホルダ" #6	CORD HOLDER (6N)	
37	062401006	1	ナヘ"コ4X10	SCREW 4X10	
38	025040233	1	ヒラサ"ガ"ネチユウ4	PLAIN WASHER 4	
39	S02657001	1	コード"オサエ	CORD HOLDER	
40	062400812	1	ナヘ"コ4X8	SCREW 4X8	
41	028040242	1	ハ"ネサ"ガ"ネ2-4	SPRING WASHER 2-4	

B. 針棒・天ビン関係/Needle bar and thread take-up mechanism/Nadelstangen und Fadenabnahmevorrichtung/
 Mécanisme de la barre à aiguille et releveur de fil/Mecanismo de la barra de aguja y tirahilos

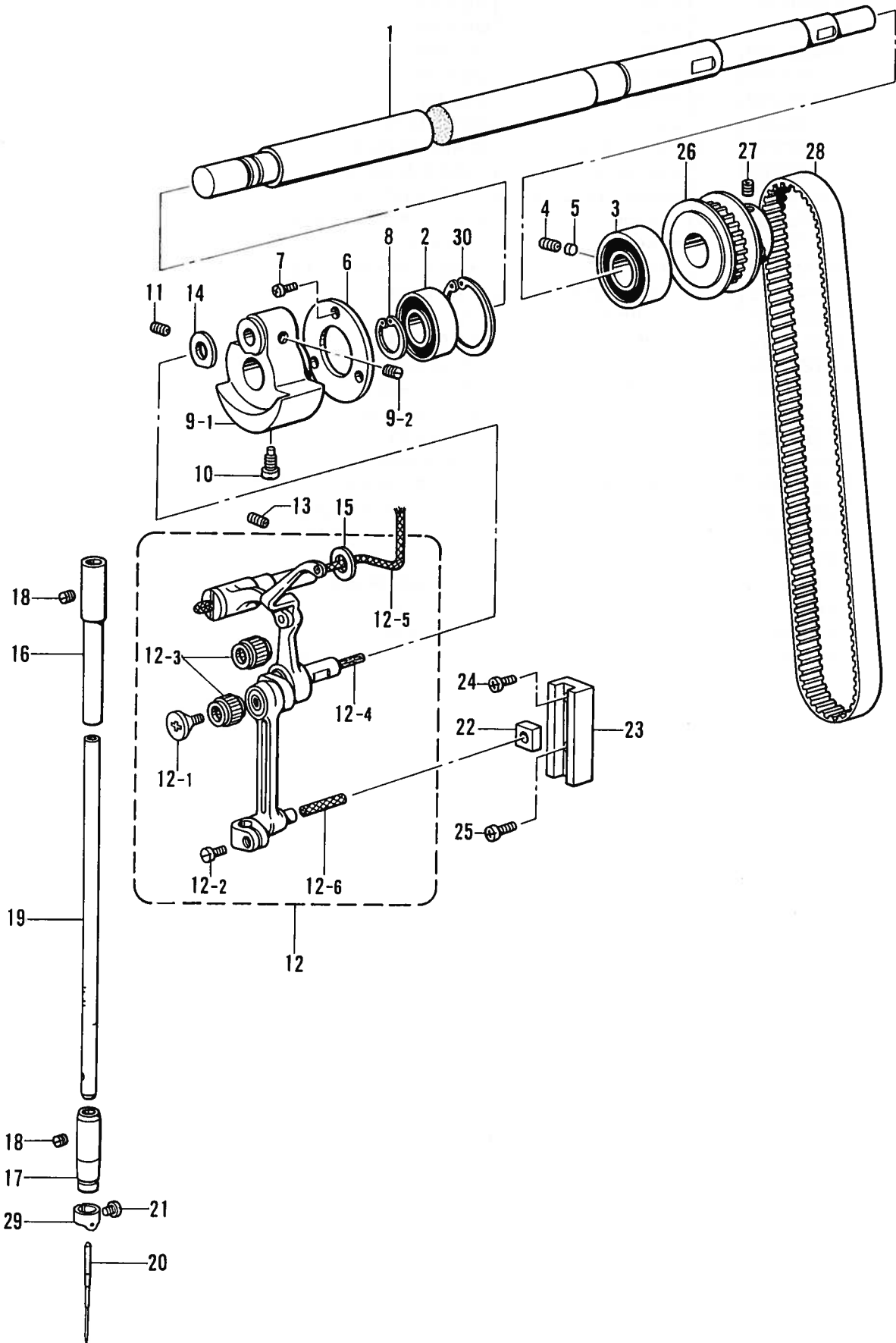

B. 針棒・天ビン関係/Needle bar and thread take-up mechanism/Nadelstangen und Fadenabnahmevorrichtung/
Mécanisme de la barre à aiguille et releveur de fil/Mecanismo de la barra de aguja y tirahilos

REF.NO.	CODE	Q'TY	ヒンメイ	NAME OF PARTS	RMKS
1	S29880001	1	ウワジツク	UPPER SHAFT	
2	S11921000	1	タマジツクウケ6002DDU	BALL BEARING 6002DDU	
3	S11922000	1	タマジツクウケ6003DDU	BALL BEARING 6003DDU	
4	014400422	1	アナトメネジ"4X4クホ"ミ	SET SCREW 4X4	
5	S01234000	1	サ"カ"ネ	WASHER	
6	S11863001	1	タマジツクウケオサエ	BALL BEARING SUPPORT	
7	062401012	3	ナヘ"コM4X10	SCREW M4X10	
8	048150142	1	トメワジツクヨウC15	STOP RING C15	
9	S02525001	1	テンヒツクランククミ	THREAD TAKE-UP CRANK ASSEMBLY	
9-1	S02526000	1	テンヒツクランク	THREAD TAKE-UP CRANK	
9-2	100251001	2	トメネジ"6.35	SET SCREW 6.35	
10	104464001	1	シメネジ"7.14	SCREW 7.14	
11	014771022	1	アナトメネジ"6.35クホ"ミ	SET SCREW 6.35	
12	S02527001	1	ハリホ"ウレンカンクミ	THREAD TAKE-UP LEVER ASSEMBLY	
12-1	145465001	1	シメネジ"3.57L	SCREW 3.57 (L)	
12-2	140004001	1	シメネジ"3.57	SCREW 3.57	
12-3	147777000	2	ニート"ルヘ"アリング"	NEEDLE BEARING	
12-4	145624000	1	フェルト	FELT	
12-5	158726001	1	クミヒモ4X4 (L=120)	WICK 4X4 (L=120)	
12-6	158727001	1	クミヒモ4X4 (L=27)	WICK 4X4 (L=27)	
13	013781012	1	トメネジ"6.35クホ"ミ	SET SCREW 6.35	
14	110367001	1	サ"カ"ネ	WASHER	
15	153596001	1	サ"カ"ネ	WASHER	
16	117242001	1	ハリホ"ウメタルU	NEEDLE BAR BUSH (U)	
17	145468001	1	ハリホ"ウメタルD	NEEDLE BAR BUSH (D)	
18	100260001	2	トメネジ"5.95	SET SCREW 5.95	
19	114908001	1	ハリホ"ウ	NEEDLE BAR	
21	140553102	1	アタマツキトメネジ"3.18	SET SCREW 3.18	
22	102630001	1	ハリホ"ウアンナイカクコマ	NEEDLE BAR GUIDE SLIDE BLOCK	
23	145688000	1	ハリホ"ウアンナイ	NEEDLE BAR GUIDE	
24	062670412	1	ナヘ"コ357-40X4	SCREW 357X4	
25	062670612	1	ナヘ"コ357-40X6	SCREW 357X6	
26	S11865001	1	タイミング"プーリU	TIMING PULLEY (U)	
27	014770622	2	アナトメネジ"6.35クホ"ミ	SET SCREW 6.35	
28	S11866000	1	タイミング"ヘルト	TIMING BELT	
29	S11867001	1	ハリホ"ウイトアンナイ	NEEDLE BAR THREAD GUIDE	
30	048320242	1	トメワアナヨウC32	STOP RING C32	
<BAS-752, 750L>					
20	S11864009	1	ミシンハリ134SERV7 (#65)	NEEDLE 134SERV7 (#65)	
20	S11864010	1	ミシンハリ134SERV7 (#70)	NEEDLE 134SERV7 (#70)	※
20	S11864012	1	ミシンハリ134SERV7 (#80)	NEEDLE 134SERV7 (#80)	
20	S11864014	1	ミシンハリ134SERV7 (#90)	NEEDLE 134SERV7 (#90)	
<BAS-754, 750KL>					
20	S25077009	1	ミシンハリ134SES (#65)	NEEDLE 134SES (#65)	※
20	S25077010	1	ミシンハリ134SES (#70)	NEEDLE 134SES (#70)	
20	S25077012	1	ミシンハリ134SES (#80)	NEEDLE 134SES (#80)	

◎ ※印の部品は標準部品です

◎ The ※ symbol is for Standard parts.

◎ Mit dem Zeichen ※ Standardteile bezeichnet.

◎ Le symbol ※ correspond aux pièces normales.

◎ El asterisco ※ es para piezas normales.

C. 針板關係 / Needle plate mechanism / Stichplattenmechanismus /
 Mécanisme de plaque à aiguille / Mecanismo de la placa de aguja

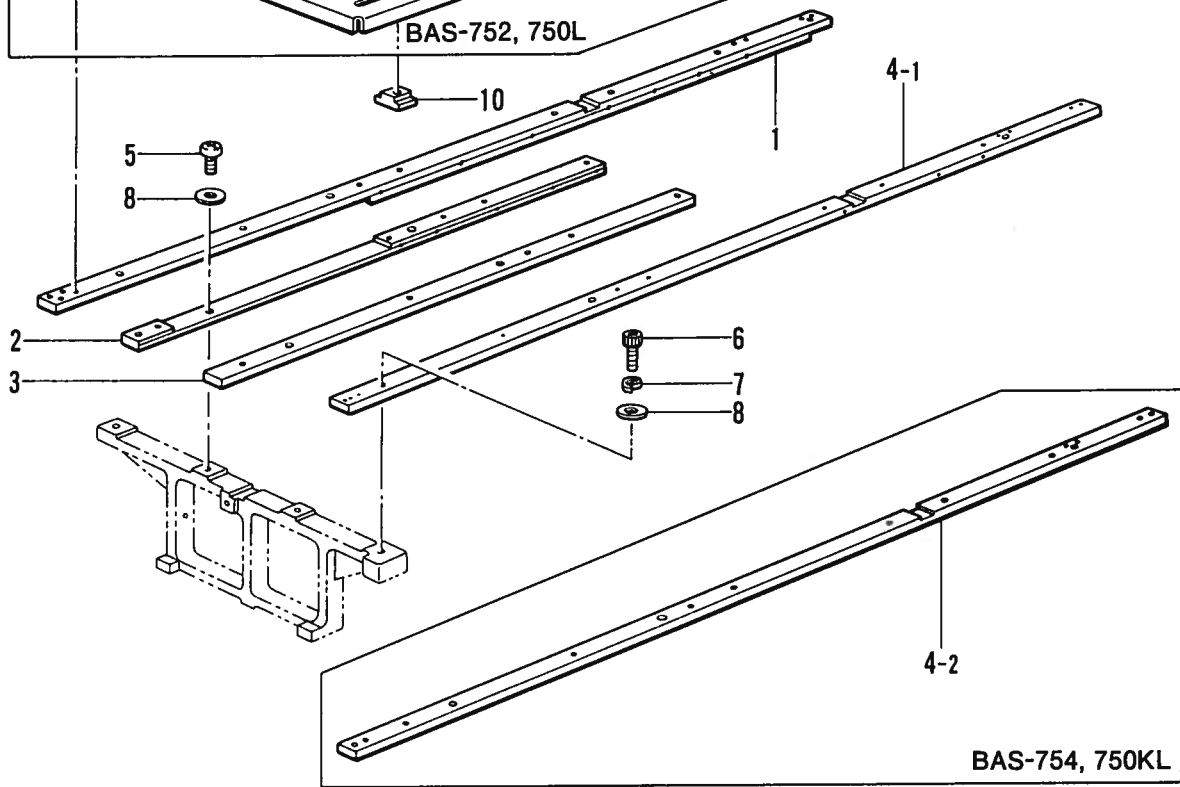
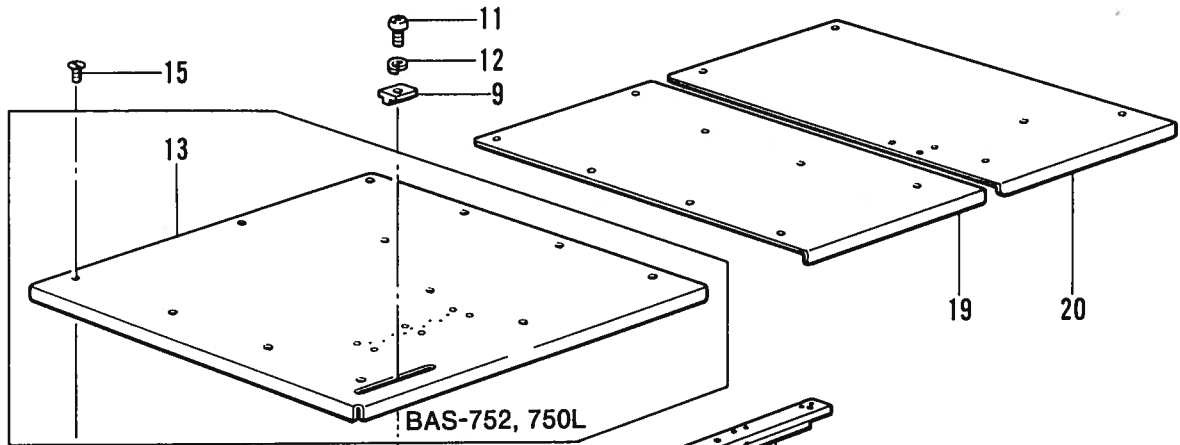
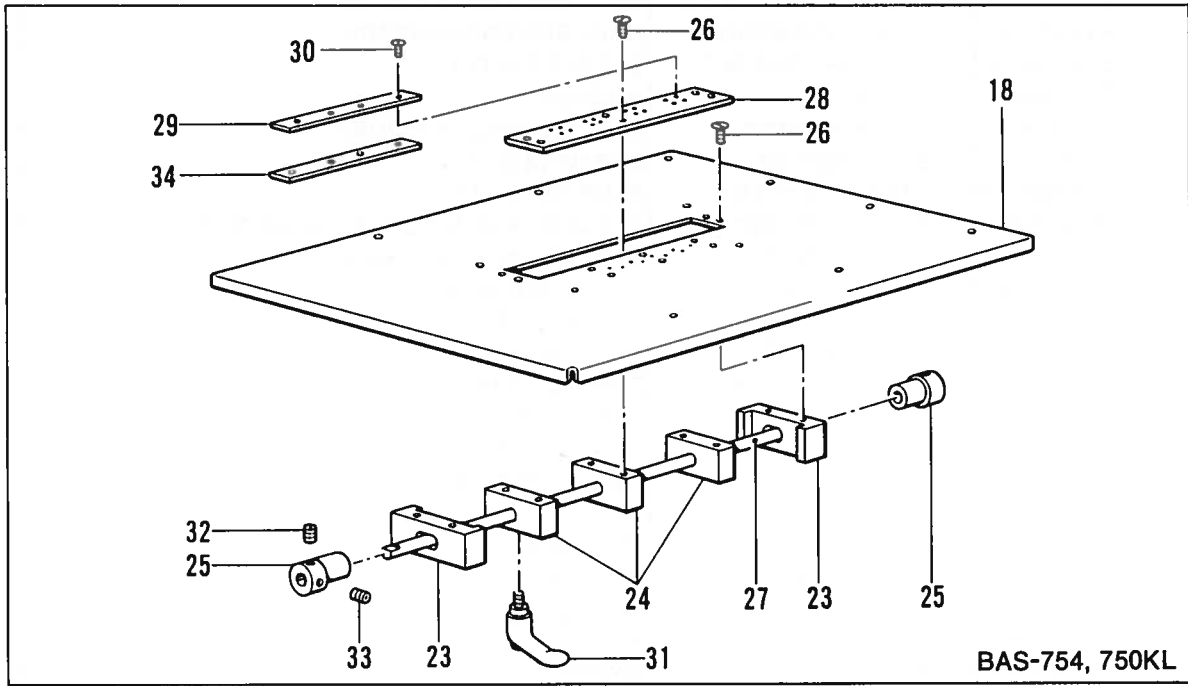

C. 針板関係/Needle plate mechanism/Stichplattenmechanismus/
 Mécanisme de plaque à aiguille/Mecanismo de la placa de aguja

REF.NO	CODE	Q'TY	ヒンメイ	NAME OF PARTS	RMKS
1	S24733001	1	ハリイタササエ1	NEEDLE PLATE SUPPORT 1	
2	S24734001	1	ハリイタササエ2	NEEDLE PLATE SUPPORT 2	
3	S24776001	1	ハリイタササエ3	NEEDLE PLATE SUPPORT 3	
5	062501202	1	ナヘ"COM5X12	SCREW M5X12	
6	018501222	9	アナホ"ルト5X12	BOLT 5X12	
7	028050242	9	ハ"ネサ"カ"ネ2-5	SPRING WASHER 2-5	
8	025050232	10	ヒラサ"カ"ネチユウ-5	PLAIN WASHER 5	
9	S11966001	1	イチキ"メウエ	POSITIONING UPPER	
10	S11967001	1	イチキ"メシタ	POSITIONING LOWER	
11	062400616	1	ナヘ"COM4X6	SCREW M4X6	
12	028040243	1	ハ"ネサ"カ"ネ2-4	SPRING WASHER 2-4	
15	100032003	24	サラネジ"4.37	SCREW 4.37	
19	S25059000	1	ハリイタタ"IRLN	NEEDLE PLATE BRACKET (RLN)	
20	S25060000	1	ハリイタタ"IRRN	NEEDLE PLATE BRACKET (RRN)	
<BAS-752, 750L>					
4-1	S31176001	1	ハリイタササエ4(シャツ)	NEEDLE PLATE SUPPORT 4	
13	S24897000	1	ハリイタタ"IL	NEEDLE PLATE BRACKET (L)	
<BAS-754, 750KL>					
4-2	S24735001	1	ハリイタササエ4	NEEDLE PLATE SUPPORT 4	
18	S24541000	1	ハリイタタ"IL	NEEDLE PLATE BRACKET (L)	
23	S24545001	2	ヘンシンシ"クササエ	ECCENTRIC SHAFT SUPPORT	
24	S24546001	3	シ"クササエ	SHAFT SUPPORT	
25	S24547001	2	ヘンシンカラー	COLLAR	
26	100032003	10	サラネジ"4.37	SCREW 4.37	
27	S24548001	1	シ"ク	SHAFT	
28	S24549000	1	ハリイタショウ	NEEDLE PLATE SMALL	
29	S24550000	1	ハリイタショウウエ1	NEEDLE PLATE SMALL UPPER 1	
30	100191003	4	サラネジ"2.38	SCREW 2.38	
31	S24561000	1	クランプレハ"ー	CLAMP LEVER	
32	013680512	3	トメネジ"4.37クホ"ミ	SET SCREW 4.37	
33	145663001	1	トメネジ"4.37	SET SCREW 4.37	
34	S24551000	1	ハリイタショウウエ2	NEEDLE PLATE SMALL UPPER 2	

D. 押工関係/Presser foot mechanism/Stoffdrückerfuß/
 Mécanisme du pied presseur/Mecanismo del prensatelas

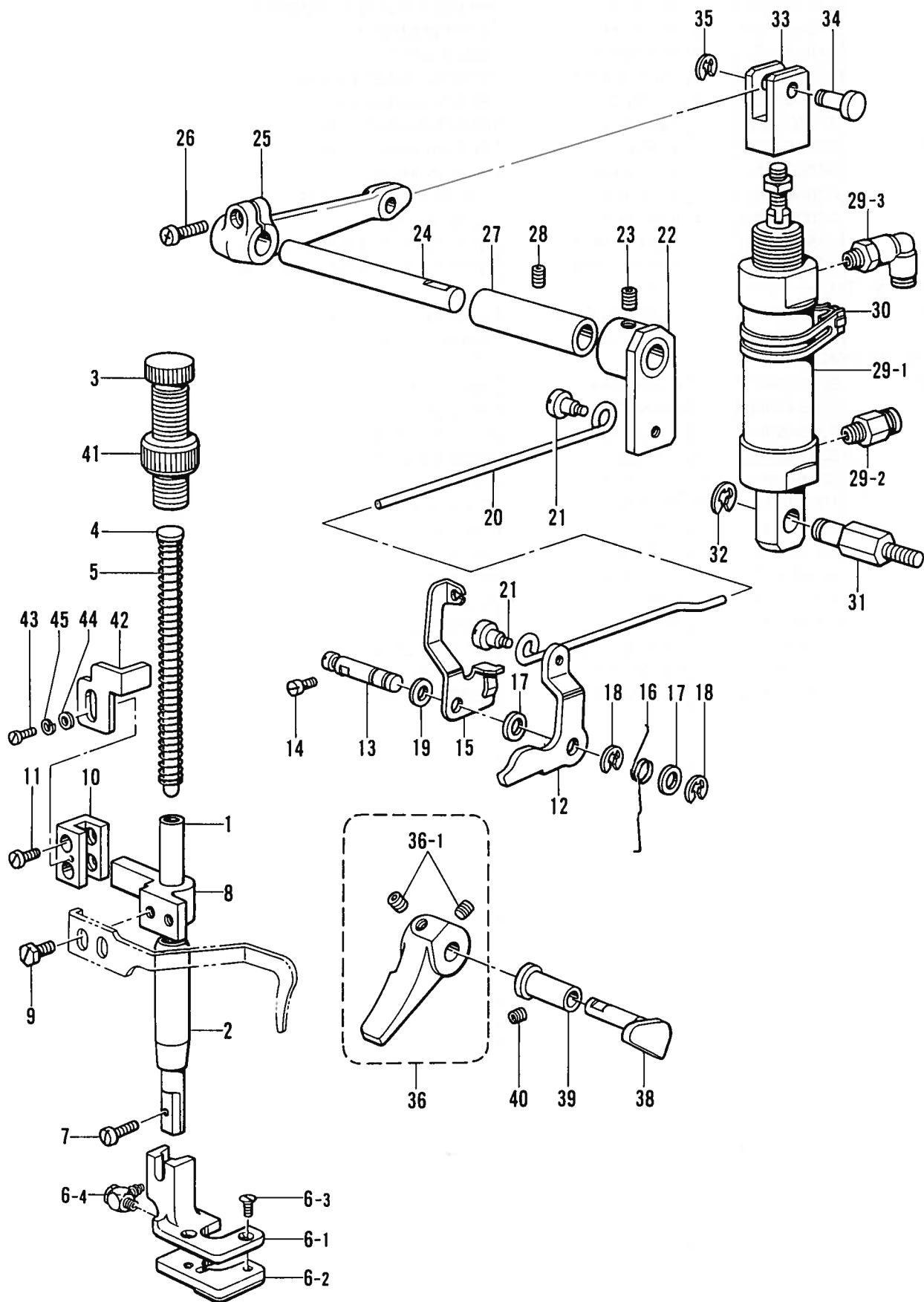

D. 押工関係/Presser foot mechanism/Stoffdrückerfuß/
Mécanisme du pied presseur/Mecanismo del prensatelas

REF.NO.	CODE	Q'TY	ヒンメイ	NAME OF PARTS	RMKS
1	111466101	1	オサエホ"ウ	PRESSER BAR	
2	145472001	1	オサエホ"ウメタル	PRESSER BAR BUSH	
3	141207001	1	オサエチヨウセツネシ"	ADJUST SCREW	
4	141208001	1	オサエハ"ネアンナイ	SPRING GUIDE	
5	157706001	1	オサエハ"ネ	SPRING	
6	S19063101	1	オサエアシクミ	WORK CLAMP ASSEMBLY	
6-1	S19064001	1	オサエアシ	WORK CLAMP	
6-2	S19065101	1	オサエイタ	PRESSER PLATE	
6-3	102538007	2	サラネシ"3.57	SCREW 3.57	
6-4	S19068000	1	エルホ"M3	ELBOW M3	
7	S13385001	1	シメネシ"3.57X10	SCREW 3.57X10	
8	S00879001	1	オサエホ"ウタ"キ	PRESSER BAR GUIDE BRACKET	
9	142403001	1	ホ"ルト5.95	BOLT 5.95	
10	S11871101	1	オサエホ"ウタ"キウケ	PRESSER BAR GUIDE BRACKET SUPPORT	
11	S11872001	2	シメネシ"4	SCREW 4	
12	145580001	1	オサエアケ"レハ"ー	PRESSER BAR LIFTER LEVER	
13	145474001	1	オサエアケ"レハ"ー"シ"ク	PRESSER BAR LIFTER LEVER SHAFT	
14	S01998001	1	アタマツキトメネシ"3.57	SET SCREW 3.57	
15	S02546201	1	イトユルメイタ	TENSION RELEASE PLATE	
16	145475101	1	オサエアケ"レハ"ー"ハ"ネ	SPRING	
17	109763002	2	サ"カ"ネ	WASHER	
18	048040342	2	トメフE4	STOP RING E4	
19	159486001	1	サ"カ"ネ	WASHER	
20	S11873001	1	オサエアケ"レンカン	PRESSER BAR LIFTER CONNECTING ROD	
21	145478001	2	タ"ンネシ"4.76	STUD SCREW 4.76	
22	S11874001	1	オサエアケ"ウテ"	PRESSER BAR LIFTER ARM	
23	014770622	2	アタメネシ"6.35クホ"ミ	SET SCREW 6.35	
24	S11875001	1	ヨウト"ウレンカン"シ"ク	ROCK CONNECTING SHAFT	
25	S11876001	1	レハ"ー	LEVER	
26	062711412	1	ナヘ"コ4.76-32X14	SCREW 476X14	
27	S11877001	1	オサエアケ"シ"クメタル	PRESSER BAR LIFTER SHAFT BUSH	
28	014500522	1	アタメネシ"5クホ"ミ	SET SCREW 5	
29	S11878000	1	オサエアケ"シリンタ"クミ	PRESSER BAR LIFTER CYLINDER ASSEMBLY	
29-1	S11879000	1	オサエアケ"シリンタ"	PRESSER BAR LIFTER CYLINDER	
29-2	S04910000	1	ハーフユニオン	HALF UNION	
29-3	S04909000	1	エルホ"ユニオン	ELBOW UNION	
30	S11880000	1	スイツチトリツケカナク"20	SWITCH SET METAL FITTING 20	
31	S11881001	1	シリンタ"ササエ	CYLINDER SUPPORT	
32	048070342	1	トメフE7	STOP RING E7	
33	S11882009	1	シリンタ"ツキ"テ	CYLINDER JOINT	
34	146153001	1	リンクピン	PIN	
35	048040342	1	トメフE4	STOP RING E4	
36	S13103009	1	オサエアケ"テコネシ"ツキ	PRESSER BAR LIFTER WITH SCREW	
36-1	014710522	2	アタメネシ"4.76クホ"ミ	SET SCREW 4.76	
38	S02551001	1	オサエアケ"クランク	PRESSER BAR LIFTER CRANK	
39	S11883001	1	オサエアケ"クランクメタル	PRESSER BAR LIFTER CRANK BUSH	
40	014400422	1	アタメネシ"4X4クホ"ミ	SET SCREW 4X4	
41	147846002	1	チヨウセツネシ"ツマミナツト	NUT	
42	S20816001	1	オサエストツハ"ー	PRESSER STOPER	
43	100257010	1	シメネシ"3.57	SCREW 3.57	
44	025350132	1	ヒラサ"カ"ネシヨウ	PLAIN WASHER	
45	028350242	1	ハ"ネサ"カ"ネ2-3.5	SPRING WASHER 2-3.5	

E1. スタッカー関係 / Stacker mechanism / Anhäufung /
 Mécanisme de l'empileur / Mecanismo de apilador

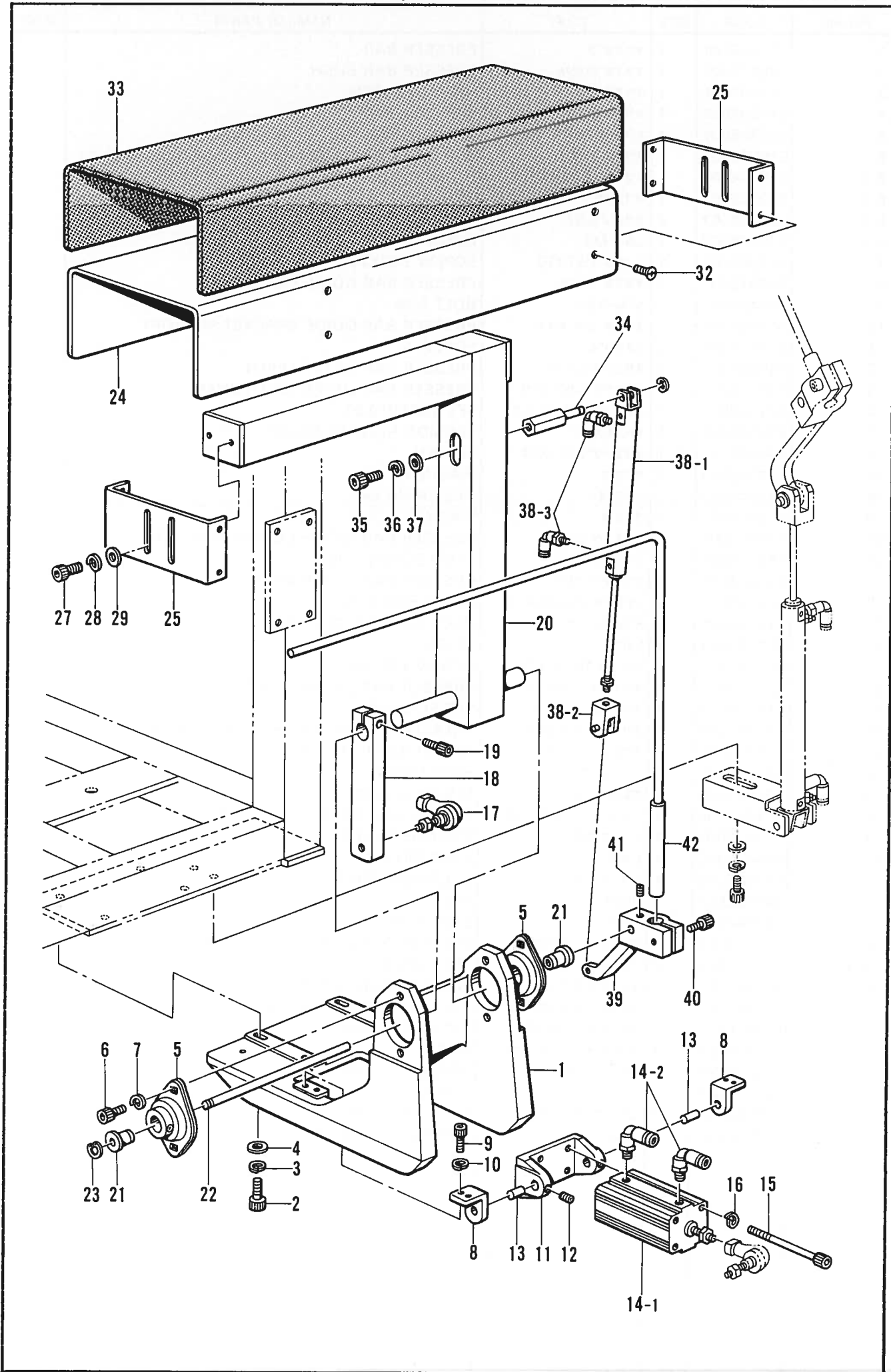

E1. スタッカー関係 / Stacker mechanism / Anhäufung /
 Mécanisme de l'empileur / Mecanismo de apilador

REF.NO.	CODE	Q'TY	ヒンメイ	NAME OF PARTS	RMKS
<ヒョウジュンスタッカーヨウ / FOR STANDARD STACKER>					
1	S11968009	1	ベース	BASE	
2	018082522	4	アナボルト8X25	BOLT 8X25	
3	028080242	4	ハネサカネ2-8	SPRING WASHER 2-8	
4	025080232	4	ヒラサカネチユウ8	PLAIN WASHER 8	
5	S11969000	2	フランジカタユニット2	FRANGE TYPE UNIT 2	
6	018081222	4	アナボルト8X12	BOLT 8X12	
7	028080242	4	ハネサカネ2-8	SPRING WASHER 2-8	
8	S11970009	2	ヒンジ	HINGE	
9	018061422	4	アナボルト6X14	BOLT 6X14	
10	028060242	4	ハネサカネ2-6	SPRING WASHER 2-6	
11	S11971009	1	ナツクル	KNUCKLE	
12	014400522	2	アナクボミ4X5	SET SCREW 4X5	
13	S11972001	2	クレビスピン	CLEVIS PIN	
14	S11973000	1	シリンダ-32X80クミ	CYLINDER 32X80 ASSEMBLY	
14-1	S11974000	1	シリンダ-32X80	CYLINDER 32X80	
14-2	S04909000	2	エルボユニオン	ELBOW UNION	
15	S11975000	4	CQ2ボルトM5X135	CQ2 BOLT M5X135	
16	028050242	4	ハネサカネ2-5	SPRING WASHER 2-5	
17	S11976000	1	リンクボール10	LINK BALL 10	
18	S11977001	1	レバー(3)	LEVER 3	
19	018062522	1	アナボルト6X25	BOLT 6X25	
20	S11978009	1	フレーム	FRAME	
21	S11979000	2	フランジブッシュ1220	FLANGE BUSH 1220	
22	S11980001	1	レバーシャフト	LEVER SHAFT	
23	048120142	1	トメワシクヨウC12	STOP RING C12	
24	S24554000	1	スタツカプレート	STACKER PLATE	
25	S17707009	2	スタツカーブラケット	STACKER BRACKET	
27	018501022	4	アナボルト5X10	BOLT 5X10	
28	028050242	4	ハネサカネ2-5	SPRING WASHER 2-5	
29	025050232	4	ヒラサカネチユウ5	PLAIN WASHER 5	
32	004400702	8	+ サラコ4X7	SCREW 4X7	
33	S24567000	1	スタツカーテーブルゴムN	STACKER TABLE RUBBER (N)	
34	S11985001	1	クレビスシャフト1	CLEVIS SHAFT 1	
35	018081222	1	アナボルト8X12	BOLT 8X12	
36	028080242	1	ハネサカネ2-8	SPRING WASHER 2-8	
37	025080232	1	ヒラサカネチユウ8	PLAIN WASHER 8	
38	S11986000	1	シリンダ-20X150Cクミ	CYLINDER 20X150 (C) ASSEMBLY	
38-1	S11987000	1	シリンダ-20X150C	CYLINDER 20X150 (C)	
38-2	S11988000	1	2ヤマナツクルシヨイント2	KNUCKLE JOINT 2	
38-3	S11426000	2	エルボユニオン4M5	ELBOW UNION 4M5	
39	S11989009	1	レバー(1)	LEVER 1	
40	018062522	1	アナボルト6X25	BOLT 6X25	
41	014060632	1	アナム6X6クボミ	SET SCREW 6X6	
42	S11990001	1	オサエ棒	PRESSER BAR	

E2. スタッカー関係 / Stacker mechanism / Anhäufung /
 Mécanisme de l'empileur / Mecanismo de apilador

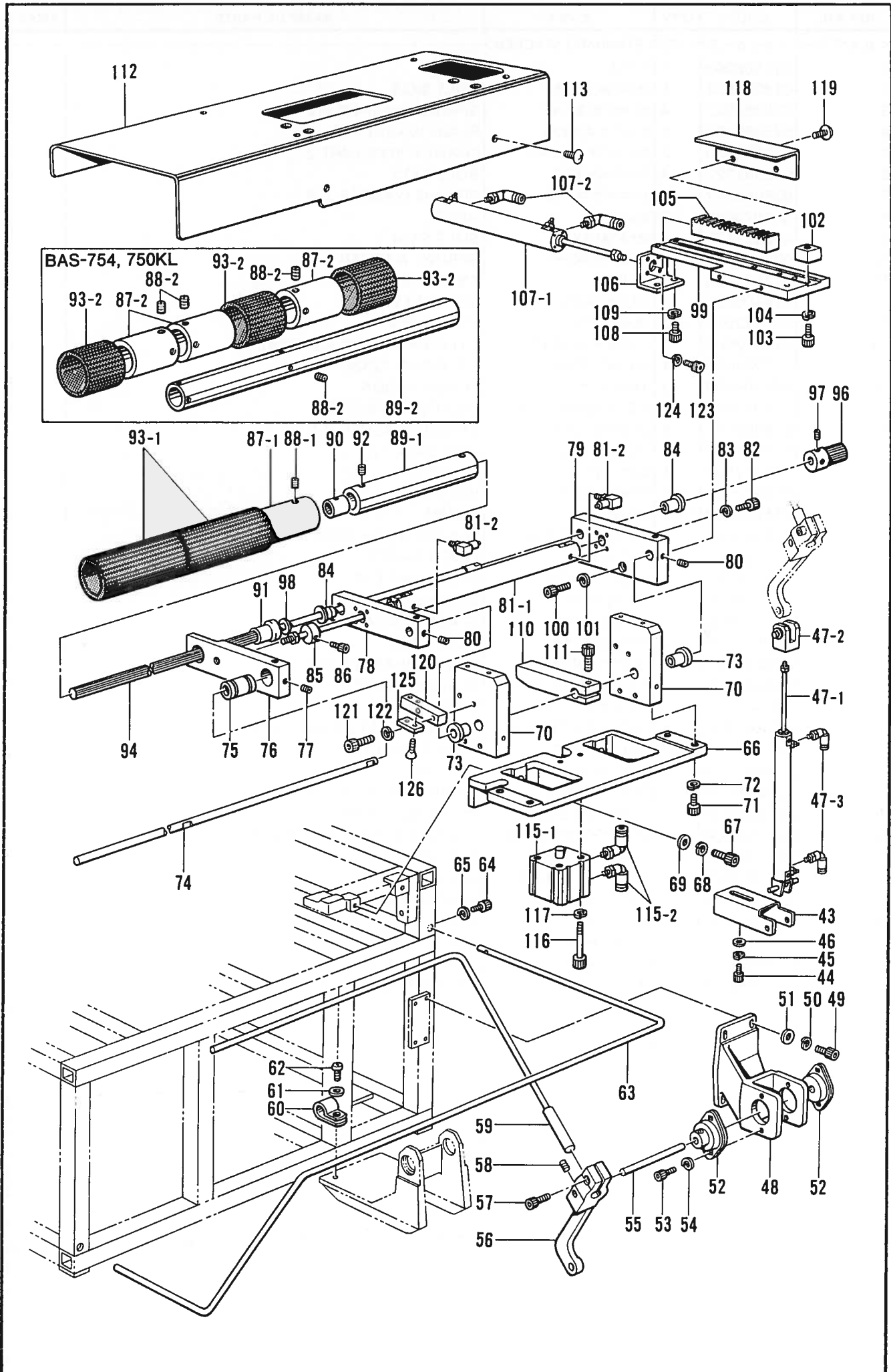

E2. スタッカ-関係 / Stacker mechanism / Anhäufung /
Mécánisme de l'empileur / Mecanismo de apilador

REF.NO.	CODE	Q'TY	ヒンメイ	NAME OF PARTS	RMKS
<ヒョウジュン・ワーキングスタッカ-ヨウ /FOR STANDARD AND WORKING STACKER>					
43	S11991001	1	スタッカ-ウケカナク	STACKER SUPPORT METAL FITTING	
44	018061422	2	アナホ"ルト6X14	BOLT 6X14	
45	028060242	2	ハ"ネサ"カ"ネ2-6	SPRING WASHER 2-6	
46	025060232	2	ヒラサ"カ"ネチユウ6	PLAIN WASHER 6	
47	S11992000	1	シリンダ"-25X200Cクミ	CYLINDER 25X200 (C) ASSEMBLY	
47-1	S11993000	1	シリンダ"-25X200C	CYLINDER 25X200 (C)	
47-2	S11994000	1	2ヤマナツクルシ"ヨイント1	KNUCKLE JOINT 1	
47-3	S11426000	2	エルホ"ユニオン4M5	ELBOW UNION 4M5	
48	S11995009	1	ヘ"ース(2)	BASE 2	
49	018062022	4	アナホ"ルト6X20	BOLT 6X20	
50	028060242	4	ハ"ネサ"カ"ネ2-6	SPRING WASHER 2-6	
51	025060232	4	ヒラサ"カ"ネチユウ6	PLAIN WASHER 6	
52	S11996000	2	フランジ"カ"タユニット	FLANGE TYPE UNIT 1	
53	018061422	4	アナホ"ルト6X14	BOLT 6X14	
54	028060242	4	ハ"ネサ"カ"ネ2-6	SPRING WASHER 2-6	
55	S11997001	1	シャフト	SHAFT	
56	S11998009	1	レハ"- (2)	LEVER 2	
57	018062522	1	アナホ"ルト6X25	BOLT 6X25	
58	014060632	1	アナトメ6X6クホ"ミ	SET SCREW 6X6	
59	S24560001	1	キシ"ハライホ"ウ	CLOTH WIPER SHAFT	
60	525907000	1	コ-ト"ホルダ"#9	CORD HOLDER (9N)	
61	025040233	1	ヒラサ"カ"ネチユウ4	PLAIN WASHER 4	
62	062400806	1	ナヘ"コ4X8	SCREW M4X8	
63	S24760009	1	スタッカ-カ-ート"	STACKER GUARD	
64	018501222	4	アナホ"ルト5X12	BOLT 5X12	
65	028050242	4	ハ"ネサ"カ"ネ2-5	SPRING WASHER 2-5	
67	018062022	2	アナホ"ルト6X20	BOLT 6X20	
68	028060242	2	ハ"ネサ"カ"ネ2-6	SPRING WASHER 2-6	
69	025060232	2	ヒラサ"カ"ネチユウ6	PLAIN WASHER 6	
73	S12002000	2	フランジ"フ"ツシユ1012	FLANGE BUSH 1012	
74	S12003000	1	LMシャフト	LM SHAFT	
75	S12004000	1	リニアフ"ツシユ	LINEAR BUSH	
76	S12005001	1	タイフ"レート	TIE PLATE	
77	014400522	2	アナクホ"ミ4X5	SET SCREW 4X5	
78	S12006000	1	エンド"フ"レートB	END PLATE (B)	
79	S12007000	1	エンド"フ"レートA	END PLATE (A)	
80	014400522	4	アナクホ"ミ4X5	SET SCREW 4X5	
81	S12008000	1	シリンダ"-20X150クミ	CYLINDER 20X150 ASSEMBLY	
81-1	S12009000	1	シリンダ"-20X150	CYLINDER 20X150	
81-2	S12150000	2	ホ-スエルホ"M-5HL-4	TUBE ELBOW (M-5HL-4)	
82	018401622	8	アナホ"ルト4X16	BOLT 4X16	
83	028040242	8	ハ"ネサ"カ"ネ2-4	SPRING WASHER 2-4	
84	S12010000	2	フランジ"フ"ツシユ1010	FLANGE BUSH 1010	
85	S12011001	1	ストツハ-	STOPPER	
86	018401022	1	アナホ"ルト4X10	BOLT 4X10	
90	S12014000	1	スプ"ラインナツト1	SPLINE NUT 1	
91	S12015000	1	スプ"ラインナツト2	SPLINE NUT 2	
92	014500522	4	アナトメネシ"5クホ"ミ	SET SCREW 5	
94	S17718000	1	スプ"ラインシ"ク	SPLINE SHAFT	
96	S12019001	1	ギ"ヤ	GEAR	
97	014500522	2	アナトメネシ"5クホ"ミ	SET SCREW 5	
98	S09027001	1	ヒラサ"カ"ネシヨウ10	PLAIN WASHER 10	
99	S12020001	1	ローラ-ガ"イト"	ROLLER GUIDE	
100	018401622	1	アナホ"ルト4X16	BOLT 4X16	
101	028040242	2	ハ"ネサ"カ"ネ2-4	SPRING WASHER 2-4	
102	S12021001	1	ラツクストツハ-	RACK STOPPER	
103	018401622	1	アナホ"ルト4X16	BOLT 4X16	
104	028040242	1	ハ"ネサ"カ"ネ2-4	SPRING WASHER 2-4	
105	S12022001	1	ラツク	RACK	
106	S12023001	1	ローラ-フ"ラケツト	ROLLER BRACKET	
107	S12024000	1	シリンダ"-20X95クミ	CYLINDER 20X95 ASSEMBLY	

E2. スタッカー関係 / Stacker mechanism / Anhäufung /
 Mécanisme de l'empileur / Mecanismo de apilador

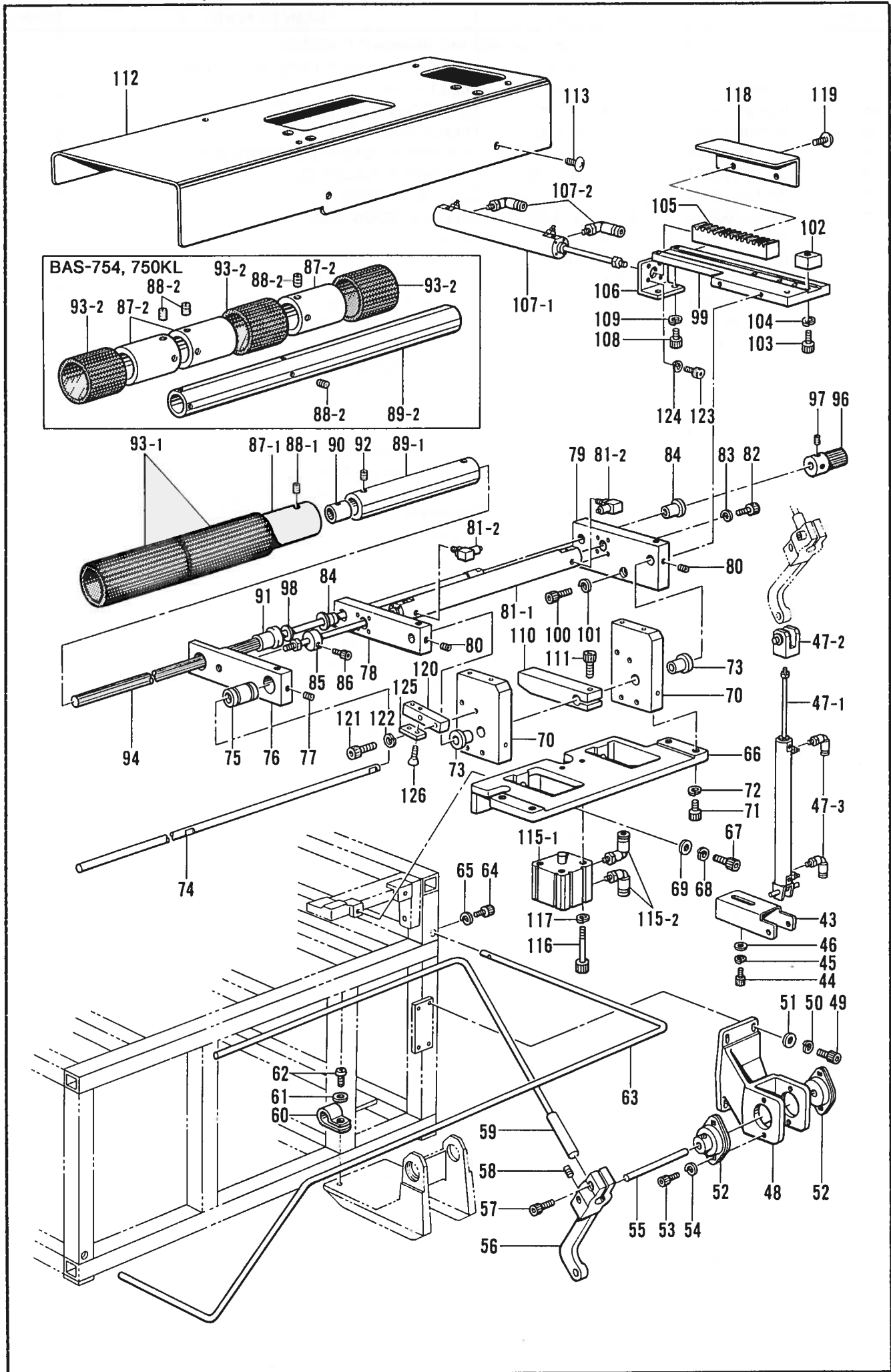

E2. スタッカー関係/Stacker mechanism/Anhäufung/
Mécanisme de l'empileur/Mecanismo de apilador

REF.NO.	CODE	Q'TY	品名	NAME OF PARTS	RMKS
107-1	S12025000	1	シリンダ"-20X95	CYLINDER 20X95	
107-2	S11426000	2	エルボ"ユニオン4M5	ELBOW UNION 4M5	
108	018401022	7	アナボ"ルト4X10	BOLT 4X10	
109	028040242	6	ハ"ネサ"カ"ネ2-4	SPRING WASHER 2-4	
110	S23398001	1	ローラレハ"	ROLLER LEVER	
111	018501622	1	アナボ"ルト5X16	BOLT 5X16	
115	S12030000	1	シリンダ"-20X15クミ	CYLINDER 20X15 ASSEMBLY	
115-1	S12031000	1	シリンダ"-20X15	CYLINDER 20X15	
115-2	S11426000	2	エルボ"ユニオン4M5	ELBOW UNION 4M5	
116	S12276000	2	CQ2ボ"ルトM5X35	CQ2 BOLT M5X35	
117	028050243	2	ハ"ネサ"カ"ネ2-5	SPRING WASHER 2-5	
118	S12033009	1	ローラカハ"-A	ROLLER COVER (A)	
119	008400604	2	+トラスコ4X6	SCREW 4X6	
120	S23395001	2	ローラストップ"ササエ	ROLLER STOPPER SUPPORT	
121	018502022	4	アナボ"ルト5X20	BOLT 5X20	
122	028050242	4	ハ"ネサ"カ"ネ2-5	SPRING WASHER 2-5	
123	018501022	4	アナボ"ルト5X10	BOLT 5X10	
124	028050242	4	ハ"ネサ"カ"ネ2-5	SPRING WASHER 2-5	
125	S23394000	2	ローラストップ"	ROLLER STOPPER	
126	004400804	4	+サラコ4X8	SCREW 4X8	
<BAS-752, 750L>					
87-1	S12012000	1	ローラ	ROLLER	
88-1	014500522	2	アナトメネシ"5クボ"ミ	SET SCREW 5	
89-1	S12013000	1	ローラササエ	ROLLER SUPPORT	
93-1	S20789000	2	スリーブ"ロール	SLEEVE ROLL	
<BAS-754, 750KL>					
87-2	S24556000	3	ローラ	ROLLER	
88-2	014500522	6	アナトメネシ"5クボ"ミ	SET SCREW 5	
89-2	S24555000	1	ローラササエ	ROLLER SUPPORT	
93-2	S24566000	3	スリーブ"ロール45	SLEEVE ROLL 45	
<キョウツウブヒン /FOR COMMON PARTS>					
66	S12000009	1	ローラヘ"ース	ROLLER BASE	
70	S23392001	2	ローラシ"クササエ	ROLLER SHAFT SUPPORT	
71	018401222	4	アナボ"ルト4X12	BOLT 4X12	
72	028040242	4	ハ"ネサ"カ"ネ2-4	SPRING WASHER 2-4	
112	S12029109	1	ローラカハ"-B	ROLLER COVER (B)	
113	008400604	6	+トラスコ4X6	SCREW 4X6	

E3. スタッカー関係 / Stacker mechanism / Anhäufung /
 Mécanisme de l'empileur / Mecanismo de apilador

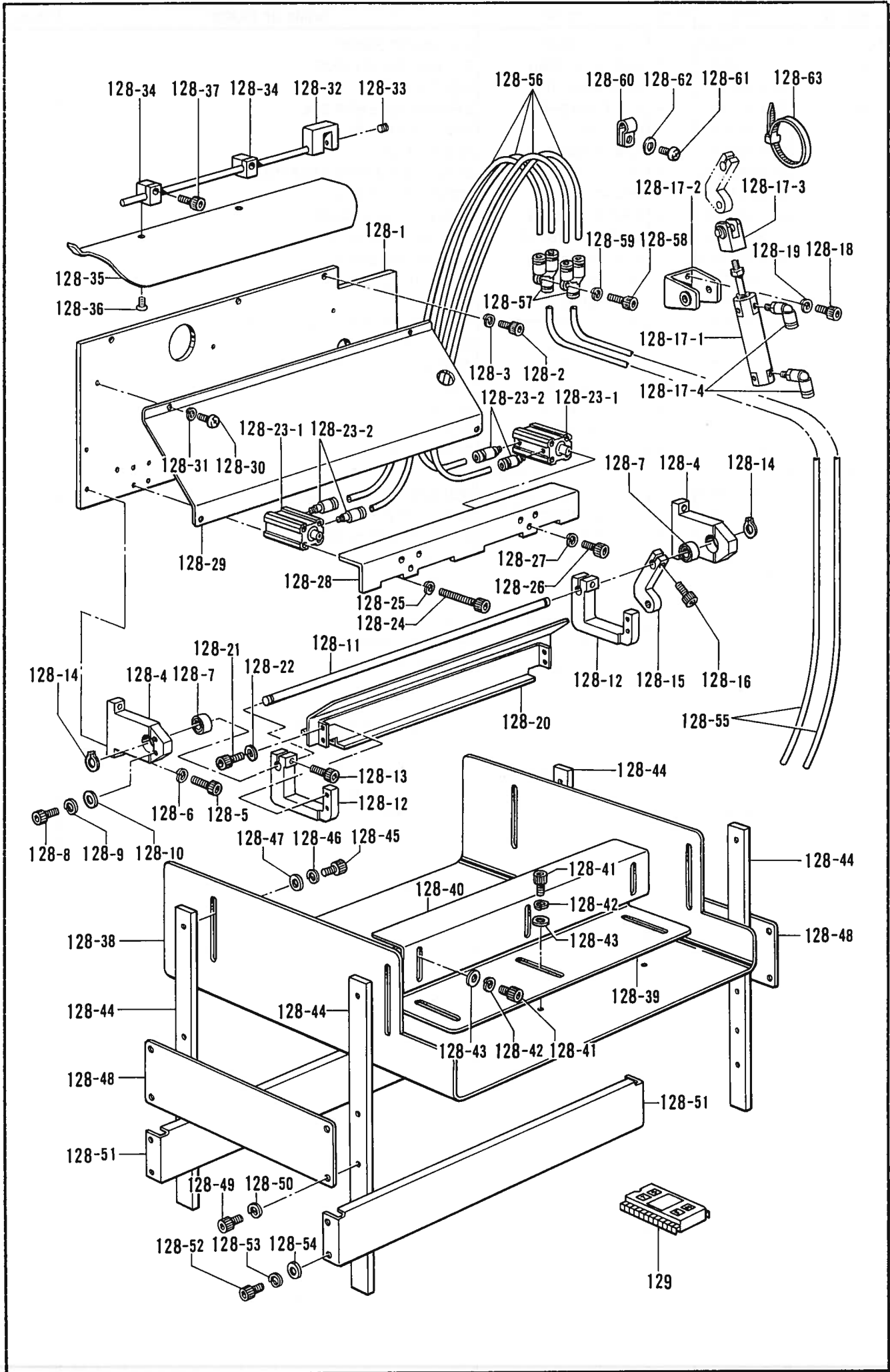

E3. スタッカー関係 / Stack mechanism / Anhäufung /
 Mécanisme de l'empileur / Mecanismo de apilador

REF.NO.	CODE	Q'TY	ヒンメイ	NAME OF PARTS	RMKS
<ワーキングスタッカーヨウ>					
128	S14461009	1	スタッカー(WORK)クミ	-----	
128-1	S14462009	1	トリツクイタ	-----	
128-2	018401022	6	アナホ"ルト4X10	-----	
128-3	028040242	6	ハ"ネサ"カ"ネ2-4	-----	
128-4	S14463009	2	ヘ"アリンク"ササエ	-----	
128-5	018501622	4	アナホ"ルト5X16	-----	
128-6	028050242	4	ハ"ネサ"カ"ネ2-5	-----	
128-7	S12078000	2	フカミゾ"タマシ"クウケ2	-----	
128-8	018400832	4	アナホ"ルト4X8	-----	
128-9	028040242	4	ハ"ネサ"カ"ネ2-4	-----	
128-10	025040232	4	ヒラサ"カ"ネチユウ4	-----	
128-11	S14464001	1	LMシャフト12	-----	
128-12	S14465009	2	レハ"-B	-----	
128-13	018502022	2	アナホ"ルト5X20	-----	
128-14	048120142	2	トメワシ"クヨウC12	-----	
128-15	S14466001	1	レハ"-A	-----	
128-16	018502022	1	アナホ"ルト5X20	-----	
128-17	S14468000	1	シリンタ"-25X70クミ	-----	
128-17-1	S14469000	1	シリンタ"-25X70	-----	
128-17-2	S12139000	1	ヨウト"ウウケカナク"1	-----	
128-17-3	S11994000	1	2ヤマナツクルシ"ヨイント1	-----	
128-17-4	S11426000	2	エルホ"ユニオン4M5	-----	
128-18	018500822	4	アナホ"ルト5X8	-----	
128-19	028050242	4	ハ"ネサ"カ"ネ2-5	-----	
128-20	S14470000	1	スヘ"リイタ	-----	
128-21	018500822	4	アナホ"ルト5X8	-----	
128-22	028050242	4	ハ"ネサ"カ"ネ2-5	-----	
128-23	S14471000	2	シリンタ"-20X40クミ	-----	
128-23-1	S14472000	2	ウスカ"タシリンタ"20X40	-----	
128-23-2	S04905000	4	ハーフユニオン	-----	
128-24	S14473000	8	CQ2ホ"ルトM5X60	-----	
128-25	028050243	16	ハ"ネサ"カ"ネ2-5	-----	
128-26	018501622	2	アナホ"ルト5X16	-----	
128-27	028050242	2	ハ"ネサ"カ"ネ2-5	-----	
128-28	S14475009	1	フ"レスイタ	-----	
128-29	S14477000	1	スヘ"リイタA	-----	
128-30	062400806	5	ナヘ"コ4X8	-----	
128-31	028040243	5	ハ"ネサ"カ"ネ2-4	-----	
128-32	S14478001	1	カ"イト"イタササエ	-----	
128-33	014500522	2	アナトメネジ"5クホ"ミ	-----	
128-34	S14479001	2	カ"イト"イタコテイ	-----	
128-35	S14480000	1	カ"イト"イタ	-----	
128-36	004400804	2	+サラコ4X8	-----	
128-37	018401622	2	アナホ"ルト4X16	-----	
128-38	S14481009	1	ミコ"ロウケ	-----	
128-39	S14482009	1	マクラシタ	-----	
128-40	S14483009	1	マクラウエ	-----	
128-41	018400832	6	アナホ"ルト4X8	-----	
128-42	028040243	6	ハ"ネサ"カ"ネ2-4	-----	
128-43	025040233	6	ヒラサ"カ"ネチユウ4	-----	
128-44	S14484009	4	スタント"	-----	
128-45	018501022	4	アナホ"ルト5X10	-----	
128-46	028050242	4	ハ"ネサ"カ"ネ2-5	-----	
128-47	025050232	4	ヒラサ"カ"ネチユウ-5	-----	
128-48	S14485009	2	レンケツイタ	-----	
128-49	018501022	8	アナホ"ルト5X10	-----	
128-50	028050242	8	ハ"ネサ"カ"ネ2-5	-----	
128-51	S14486009	2	コテイイタ	-----	
128-52	018501022	8	アナホ"ルト5X10	-----	
128-53	028050242	8	ハ"ネサ"カ"ネ2-5	-----	
128-54	025050232	8	ヒラサ"カ"ネチユウ-5	-----	

E3. スタッカー関係 / Stacker mechanism / Anhäufung /
 Mécanisme de l'empileur / Mecanismo de apilador

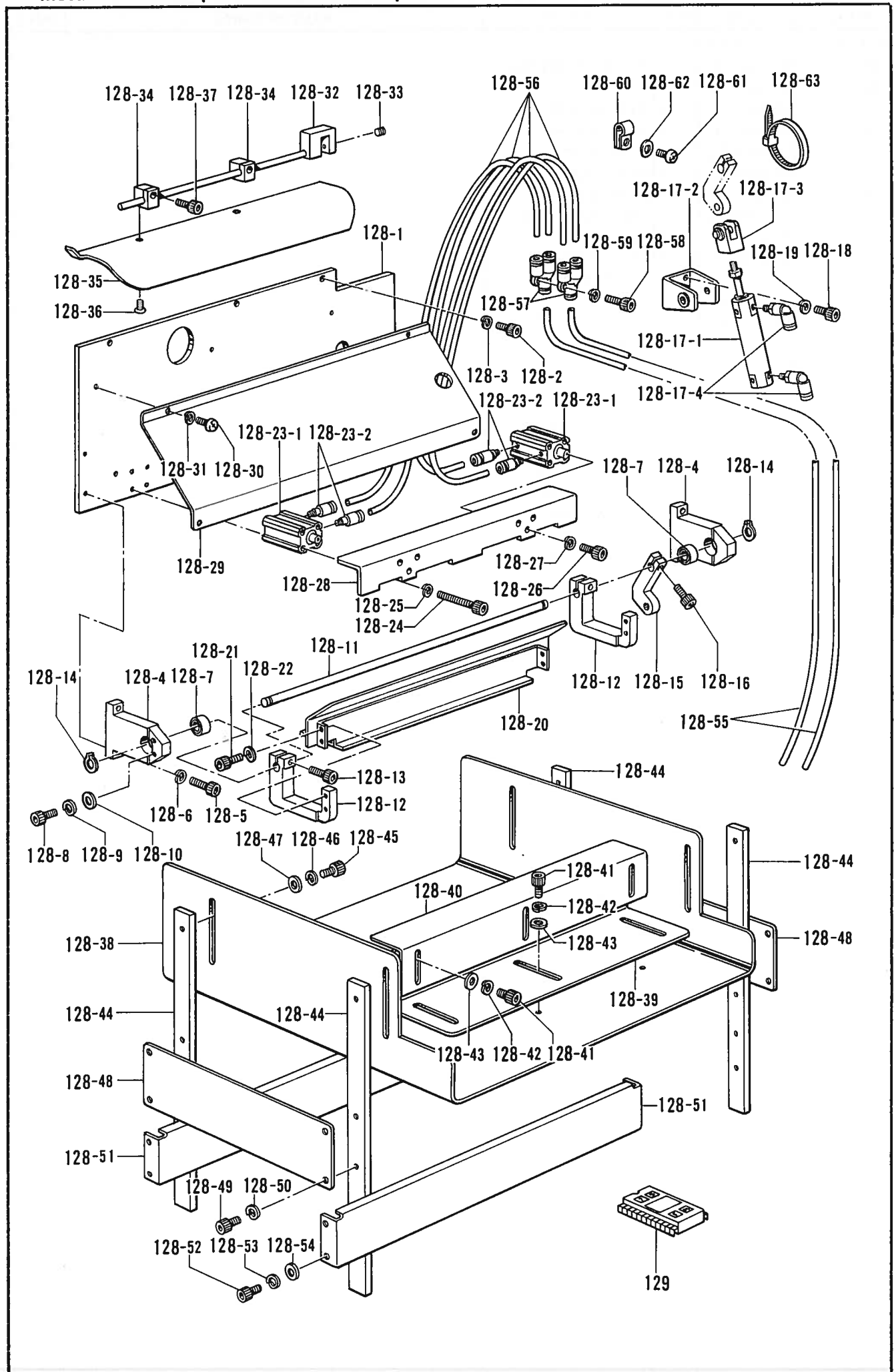

E3. スタッカー関係/Stacker mechanism/Anhäufung/
 Mécanisme de l'empileur/Mecanismo de apilador

REF.NO.	CODE	Q'TY	品名	NAME OF PARTS	RMKS
128-55	S12195000	2	エアホース4X2.5-19	-----	
128-56	S12183000	4	エアホース4X2.5-7	-----	
128-57	S12104000	2	ユニオンワイ4	-----	
128-58	018402522	1	アナホルト4X25	-----	
128-59	028040242	1	ハネサカネ2-4	-----	
128-60	525664000	2	コートホルダ#6	-----	
128-61	062400806	2	ナベコ4X8	-----	
128-62	025040233	2	ヒラサカネチユウ4	-----	
128-63	S04159000	3	ハント1M	-----	
129	S12057200	1	PROM750-02(ワーク)	-----	

F. 駆動側・送り関係 / Drive, feed mechanism / Transporvorrichtung /
 Mécanisme d'alimentation, entraînement / Mecanismo de la alimentación, mando

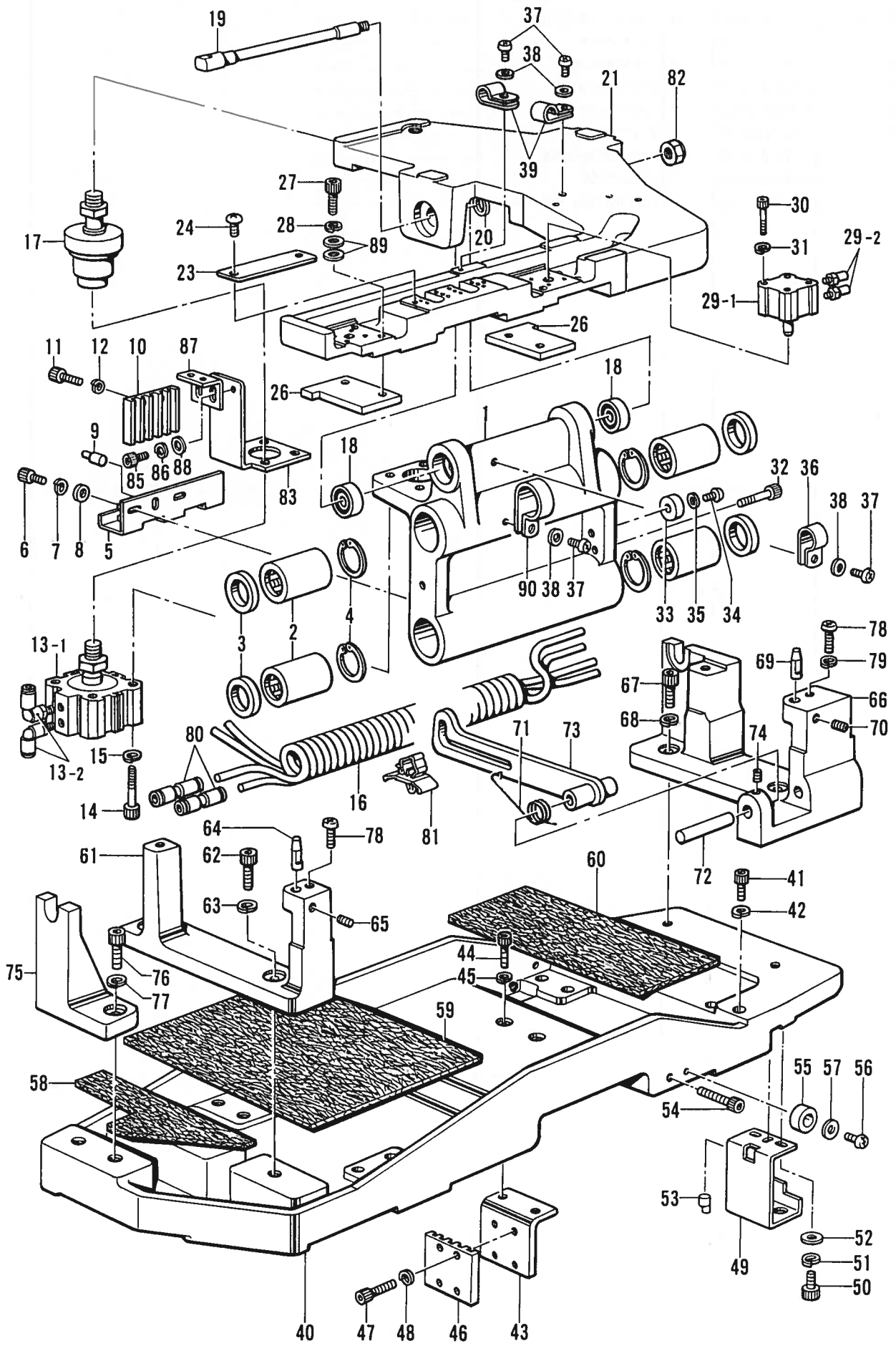

F. 駆動側・送り関係 / Drive, feed mechanism / Transporvorrichtung /
 Mécanisme d'alimentation, entraînement / Mecanismo de la alimentación, mando

REF. NO.	CODE	Q'TY	ヒンメイ	NAME OF PARTS	RMKS
1	S17719009	1	オサエサエ	PRESSER SUPPORT	
2	S12035000	4	リニアボールへ"アリング"	LINEAR BALL BEARING	
3	S12036000	4	クミアワセシール	COMBINATION SEAL	
4	048350242	4	トメワアナヨウC35	STOP RING C35	
5	S17706001	1	スリットB	SLIT (B)	
6	018400832	2	アナホルト4X8	BOLT 4X8	
7	028040242	2	ハ"ネサ"カ"ネ2-4	SPRING WASHER 2-4	
8	025040232	2	ヒラサ"カ"ネチユウ4	PLAIN WASHER 4	
9	S12038001	1	スリットピン	PIN	
10	S12039001	1	ベルトホジ"イタB	BELT RETENTION PLATE (B)	
11	018501622	4	アナホルト5X16	BOLT 5X16	
12	028050242	4	ハ"ネサ"カ"ネ2-5	SPRING WASHER 2-5	
13	S17725000	1	シリンダ"ー40X5クミ	CYLINDER 40X5 ASSEMBLY	
13-1	S17726000	1	シリンダ"ー40X5	CYLINDER 40X5	
13-2	S04909000	2	エルボ"ユニオン	ELBOW UNION	
14	S19553000	4	CQ2ホルトM5X40	CQ2 BOLT M5X40	
15	028050243	4	ハ"ネサ"カ"ネ2-5	SPRING WASHER 2-5	
16	S04907000	1	スパイラルホース	SPIRAL TUBE	
17	S12044000	1	フローティング"ジョイント	FLOATING JOINT	
18	S12045000	2	アンキ"ユラタマシ"クウケ1	ANGULAR BALL BEARING 1	
19	S15538001	1	ポケットオサエシ"ク	POCKET PRESSER SHAFT	
20	S15539001	1	カラ"ー2-15	COLLAR 2-15	
21	S17716009	1	オサエ	PRESSER FOOT	
23	S17717009	1	オサエカバー	COVER	
24	008400604	2	+トラスコ4X6	SCREW 4X6	
26	S12050001	2	ブロックササエ	BLOCK SUPPORT	
27	018502022	4	アナホルト5X20	BOLT 5X20	
28	028050242	4	ハ"ネサ"カ"ネ2-5	SPRING WASHER 2-5	
29	S12051000	2	ロックシリンダ"ークミA	LOCK CYLINDER ASSEMBLY (A)	
29-1	S12052000	2	ロックシリンダ"ー	LOCK CYLINDER	
29-2	S11433000	4	ホースニツフル4M5	HOSE NIPPLE 4M5	
30	S12053000	8	CQ2ホルトM3X25	CQ2 BOLT M3X25	
31	028030243	8	ハ"ネサ"カ"ネ2-3	SPRING WASHER 2-3	
32	S19553000	1	CQ2ホルトM5X40	CQ2 BOLT M5X40	
33	S12054000	2	クッション	CUSHION	
34	062400806	2	ナヘ"コ4X8	SCREW M4X8	
35	025040233	2	ヒラサ"カ"ネチユウ4	PLAIN WASHER 4	
36	525664000	1	コード"ホルダ"ー#6	CORD HOLDER (6N)	
37	062400806	4	ナヘ"コ4X8	SCREW M4X8	
38	025040233	4	ヒラサ"カ"ネチユウ4	PLAIN WASHER 4	
39	525907000	2	コード"ホルダ"ー#9	CORD HOLDER (9N)	
40	S15540000	1	ミシンササエ	HEAD SUPPORT	
41	018401622	16	アナホルト4X16	BOLT 4X16	
42	028040242	16	ハ"ネサ"カ"ネ2-4	SPRING WASHER 2-4	
43	S12056001	1	ベルトホジ"イタA	BELT HOLD PLATE (A)	
44	018502022	2	アナホルト5X20	BOLT 5X20	
45	028050242	2	ハ"ネサ"カ"ネ2-5	SPRING WASHER 2-5	
46	S12039001	1	ベルトホジ"イタB	BELT RETENTION PLATE (B)	
47	018501622	4	アナホルト5X16	BOLT 5X16	
48	028050242	4	ハ"ネサ"カ"ネ2-5	SPRING WASHER 2-5	
49	S24832001	1	スリットC	SLIT (C)	
50	018400832	2	アナホルト4X8	BOLT 4X8	
51	028040242	2	ハ"ネサ"カ"ネ2-4	SPRING WASHER 2-4	
52	025040232	2	ヒラサ"カ"ネチユウ4	PLAIN WASHER 4	
53	S12038001	1	スリットピン	PIN	
54	018502522	1	アナホルト5X25	BOLT 5X25	
55	S12054000	2	クッション	CUSHION	
56	062400806	2	ナヘ"コ4X8	SCREW M4X8	
57	025040232	2	ヒラサ"カ"ネチユウ4	PLAIN WASHER 4	
58	S12268000	1	フェルトL	FELT (L)	
59	S12269000	1	フェルトM	FELT (M)	
60	S12270000	1	フェルトR	FELT (R)	

F. 駆動側・送り関係/Drive, feed mechanism/Transporvorrichtung/
 Mécanisme d'alimentation, entraînement/Mecanismo de la alimentación, mando

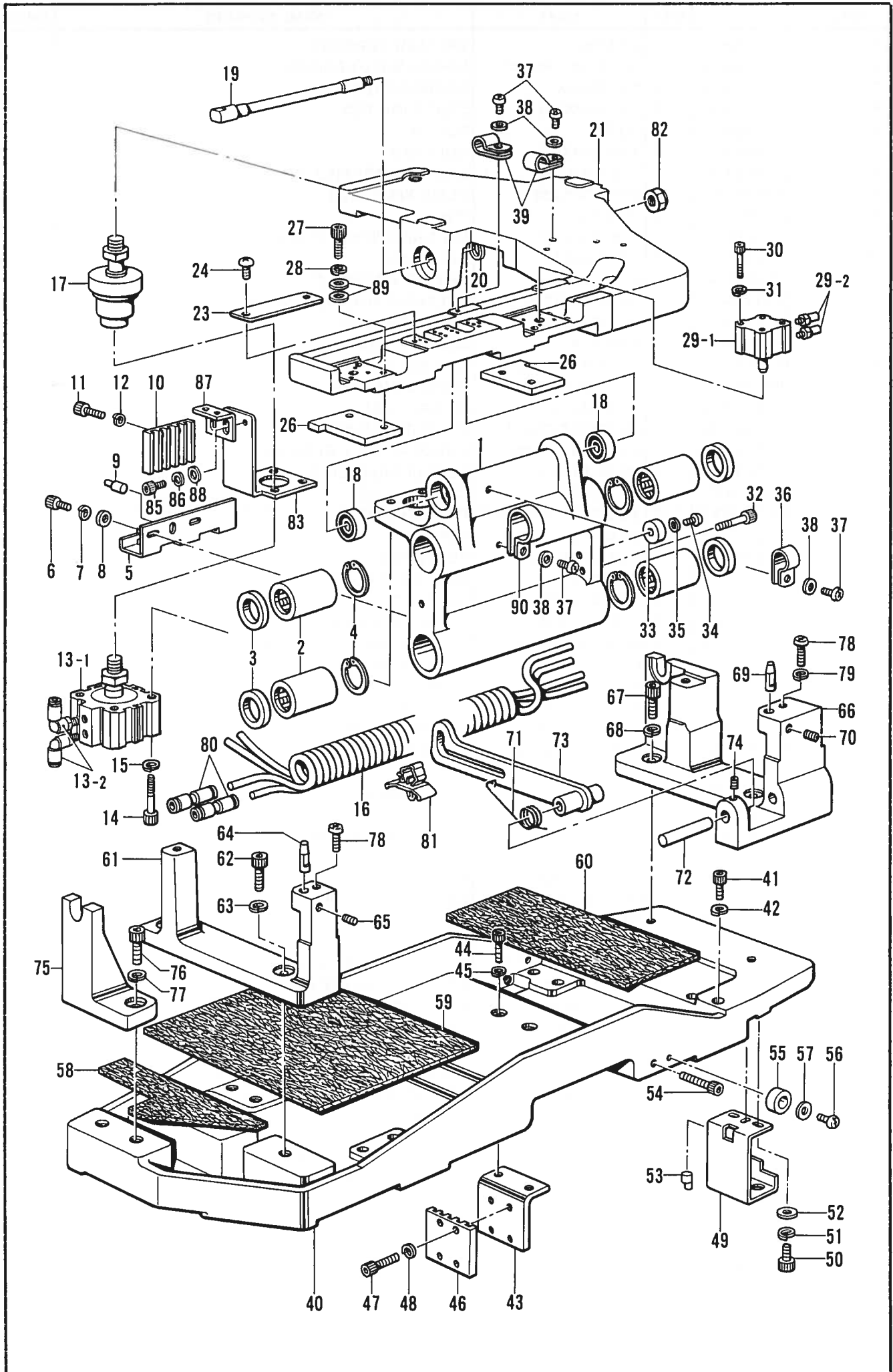

F. 駆動側・送り関係 / Drive, feed mechanism / Transporvorrichtung /
 Mécanisme d'alimentation, entraînement / Mecanismo de la alimentación, mando

REF.NO.	CODE	Q'TY	ヒンメイ	NAME OF PARTS	RMKS
61	S12059009	1	ミシンウケタ"IL	HEAD SUPPORT BASE (L)	
62	018082022	2	アナボ"ルト8X20	BOLT 8X20	
63	028080242	2	ハ"ネサ"カ"ネ2-8	SPRING WASHER 2-8	
64	S12060001	1	イチキ"メピン	POSITIONING PIN	
65	014500522	1	アナトメネシ"5クホ"ミ	SET SCREW 5	
66	S12061009	1	ミシンウケタ"IR	HEAD SUPPORT (R)	
67	018082022	2	アナボ"ルト8X20	BOLT 8X20	
68	028080242	2	ハ"ネサ"カ"ネ2-8	SPRING WASHER 2-8	
69	S12060001	1	イチキ"メピン	POSITIONING PIN	
70	014500522	1	アナトメネシ"5クホ"ミ	SET SCREW 5	
71	152859001	1	トウフ"ササエレハ"ーハ"ネ	SPRING	
72	152858001	1	トウフ"ササエレハ"ーシ"ク	HEAD SUPPORT LEVER SHAFT	
73	152857001	1	トウフ"ササエレハ"ー	HEAD SUPPORT LEVER	
74	014400522	1	アナクホ"ミ4X5	SET SCREW 4X5	
75	S12062009	1	トウフ"ウケ	HEAD BASE	
76	018082022	2	アナボ"ルト8X20	BOLT 8X20	
77	028080242	2	ハ"ネサ"カ"ネ2-8	SPRING WASHER 2-8	
78	062501202	4	ナヘ"コM5X12	SCREW M5X12	
79	028050242	2	ハ"ネサ"カ"ネ2-5	SPRING WASHER 2-5	
80	S04587000	2	ストレートツキ"テ	STRAIGHT JOINT	
81	150349001	1	コート"クランプ"10	CORD CLAMP 10-L	
82	S15545000	1	UナットM8P1	U-NUT M8P1	
83	S17724001	1	センサートリツケイタシタ	SENSOR SET PLATE LOWER	
85	018400832	2	アナボ"ルト4X8	BOLT 4X8	
86	028040242	2	ハ"ネサ"カ"ネ2-4	SPRING WASHER 2-4	
87	S15551001	1	センサートリツケイタウエ	SENSOR SET PLATE UPPER	
88	025040232	2	ヒラサ"カ"ネチユウ4	PLAIN WASHER 4	
89	113431002	8	サ"カ"ネ	WASHER	
90	554482000	1	コート"ホルタ"12	CORD HOLDER (12N)	

G. 送り案内関係/Feed guide mechanism/Transportführung/
 Mécanisme du guide de l'entraînement/Mecanismo de la guía de alimentación

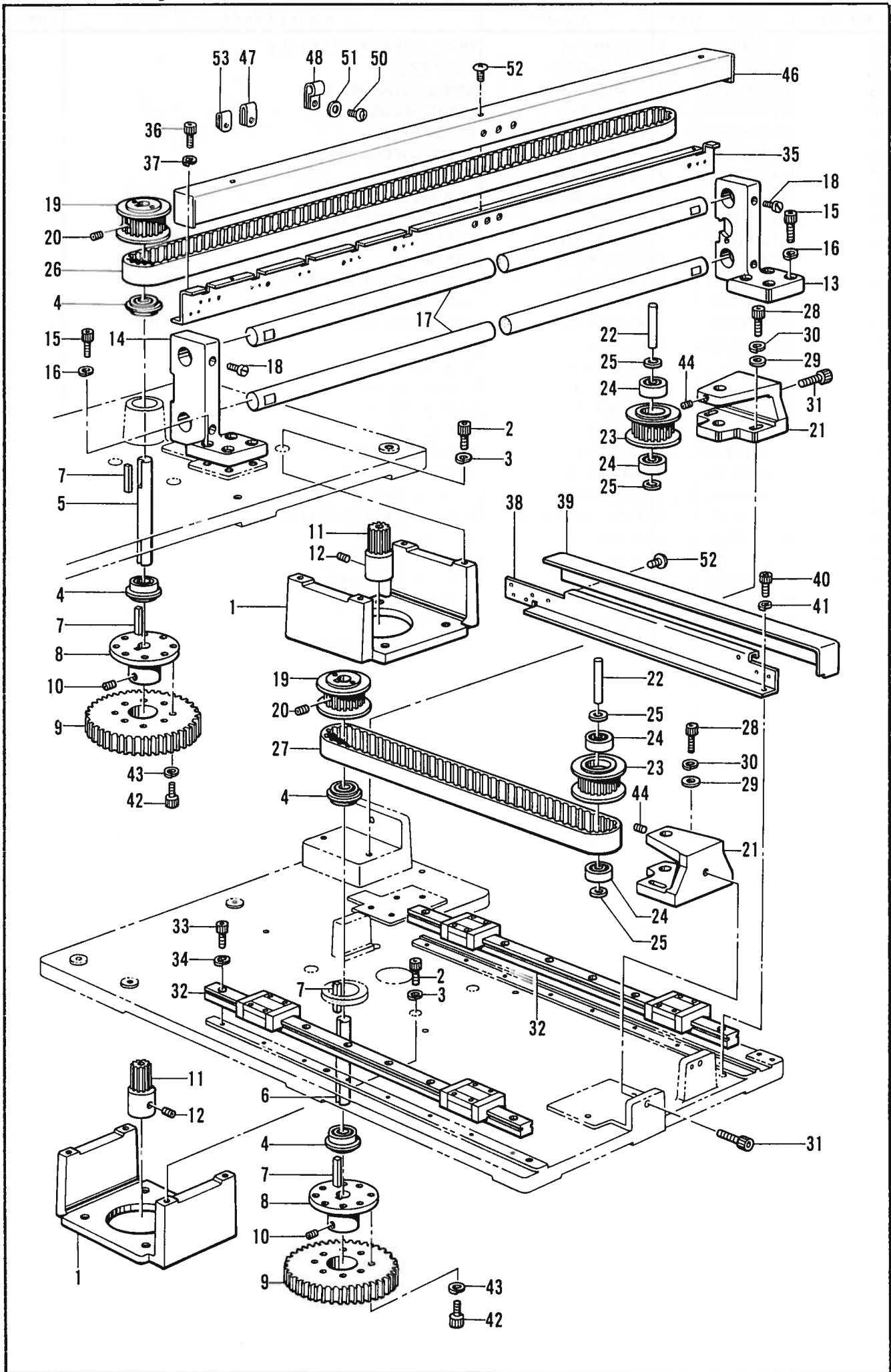

G. 送り案内関係/Feed guide mechanism/Transportführung/
 Mécanisme du guide de l'entraînement/Mecanismo de la guía de alimentación

REF.NO.	CODE	Q'TY	ヒンメイ	NAME OF PARTS	RMKS
1	S12063009	2	モーターササエ	MOTOR SUPPORT	
2	018062022	8	アナボルト6X20	BOLT 6X20	
3	028060242	8	ハネサカネ2-6	SPRING WASHER 2-6	
4	076002450	4	タマシクウケ6002DD	BALL BEARING 6002DD	
5	S12065000	1	プーリージクA	PULLEY SHAFT (A)	
6	S12066000	1	プーリージクB	PULLEY SHAFT (B)	
7	S12067000	4	キー	KEY	
8	S12068001	2	キヤササエ	GEAR SUPPORT	
9	S12069000	2	ナイロンキヤ	NYLON GEAR	
10	014060632	2	アナム6X6クホミ	SET SCREW 6X6	
11	S12070000	2	キヤ	GEAR	
12	014060632	4	アナム6X6クホミ	SET SCREW 6X6	
13	S23403001	1	シャフトササエミキ	SHAFT SUPPORT RIGHT	
14	S23404001	1	シャフトササエヒタリ	SHAFT SUPPORT LEFT	
15	018062522	8	アナボルト6X25	BOLT 6X25	
16	028060242	8	ハネサカネ2-6	SPRING WASHER 2-6	
17	S24767001	2	LMシャフト25	LM SHAFT 25	
18	150949001	4	ナカオサエチヨウセツネシ	ADJUSTING SCREW	
19	S12074000	2	プーリーB	PULLEY (B)	
20	014060632	2	アナム6X6クホミ	SET SCREW 6X6	
21	S12075002	2	プーリーササエA	PULLEY SUPPORT (A)	
22	S12076000	2	プーリージクD	PULLEY SHAFT (D)	
23	S12077000	2	プーリーA	PULLEY (A)	
24	S12078000	4	フカミゾタマシクウケ2	DEEP GROOVE BALL BEARING 2	
25	S12079000	4	カラー2	COLLAR 2	
26	S24768000	1	タイミングベルトA	TIMING BELT (A)	
27	S12081000	1	タイミングベルトB	TIMING BELT (B)	
28	018062022	4	アナボルト6X20	BOLT 6X20	
29	025060232	4	ヒラサカネチユウ6	PLAIN WASHER 6	
30	028060242	4	ハネサカネ2-6	SPRING WASHER 2-6	
31	018063022	2	アナボルト6X30	BOLT 6X30	
32	S12082000	2	リニアガイド	LINEAR GUIDE	
33	018401622	16	アナボルト4X16	BOLT 4X16	
34	028040242	16	ハネサカネ2-4	SPRING WASHER 2-4	
35	S24769001	1	カバーササエ	COVER SUPPORT	
36	018400832	3	アナボルト4X8	BOLT 4X8	
37	028040242	3	ハネサカネ2-4	SPRING WASHER 2-4	
38	S24830001	1	リミットササエY	LIMIT SUPPORT (Y)	
39	S24831001	1	リミットササエカバーY	LIMIT SUPPORT COVER (Y)	
40	018400832	2	アナボルト4X8	BOLT 4X8	
41	028040242	2	ハネサカネ2-4	SPRING WASHER 2-4	
42	018501622	16	アナボルト5X16	BOLT 5X16	
43	028050242	16	ハネサカネ2-5	SPRING WASHER 2-5	
44	014400522	2	アナクホミ4X5	SET SCREW 4X5	
46	S24770001	1	センサーカバー	SENSOR COVER	
47	S10243000	2	ナイロンクランプNK-3N	CORD HOLDER NK-3N	
48	149547000	2	コートオサエ	CORD HOLDER (4N)	
50	062400806	6	ナヘコ4X8	SCREW M4X8	
51	025040233	6	ヒラサカネチユウ4	PLAIN WASHER 4	
52	008400604	6	+トラスコ4X6	SCREW 4X6	
53	S11816000	3	クランプNK-2N	CLAMP NK-2N	

H1. ボトム関係/Bottom mechanism/Unterer Mechanismus/
Mécánisme inférieur/Mecanismo del fondo

<BAS-752, 750L>

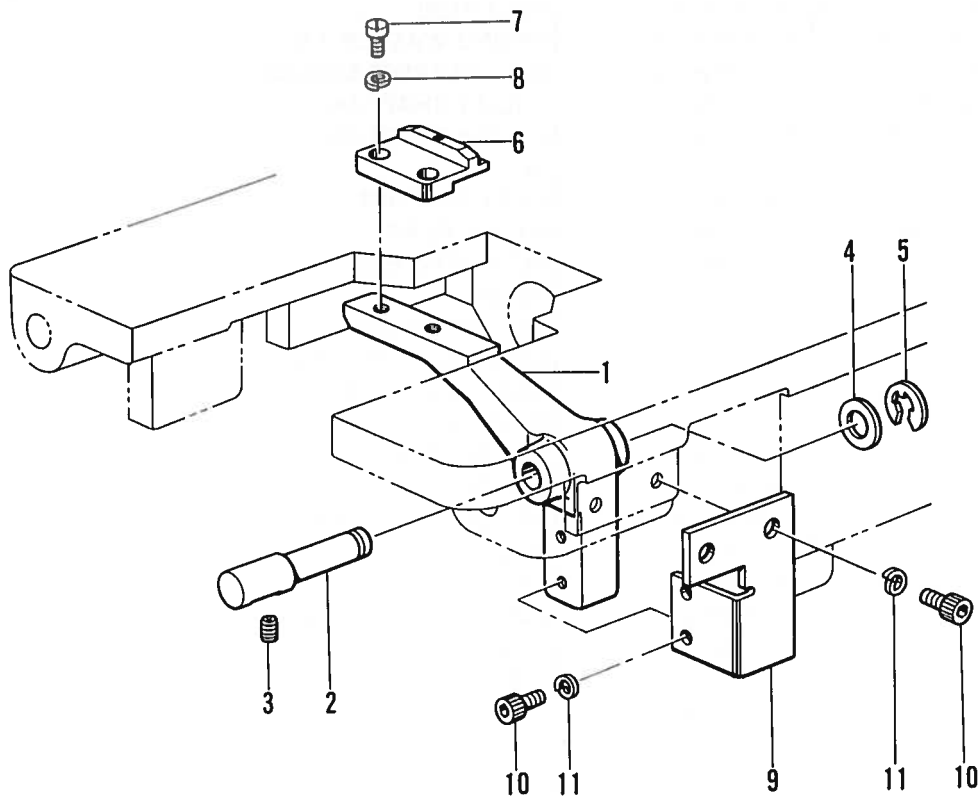

H2. ボトム関係/Bottom mechanism/Unterer Mechanismus/
Mécánisme inférieur/Mecanismo del fondo

<BAS-754, 750KL>

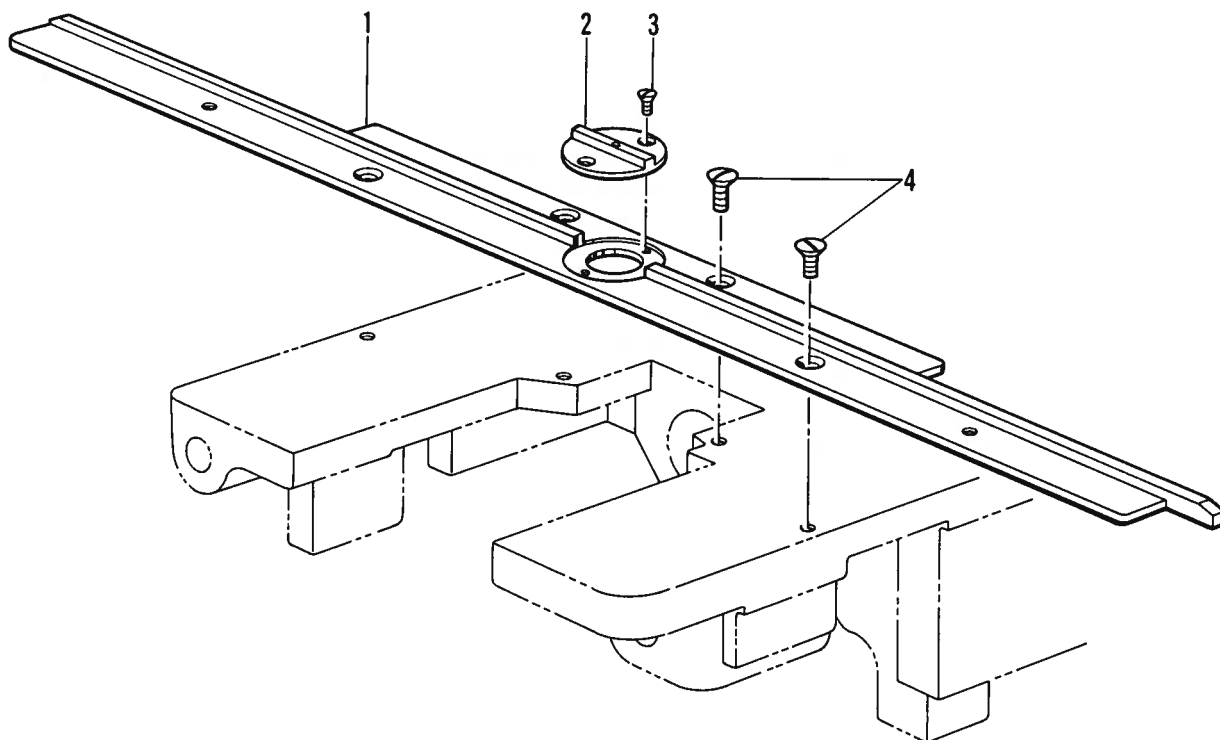

H1. ボトム関係/Bottom mechanism/Unterer Mechanismus/
Mécanisme inférieur/Mecanismo del fondo

REF NO	CODE	Q'TY	ヒンメイ	NAME OF PARTS	RMKS
<BAS-752, 750L>					
1	S11887101	1	ボトムレバー	BOTTOM LEVER	
2	S11888001	1	ボトムレバーシャフト	BOTTOM LEVER SHAFT	
3	014500522	1	アナメネジ5クホミ	SET SCREW 5	
4	153113001	1	スラストサカネ	THRUST WASHER	
5	048060342	1	トメワE6	STOP RING E6	
6	S11889001	1	ボトムプランシヤ(φ1.6)	BOTTOM PLUNGER (φ1.6)	
7	100080003	2	シメネジ3.18	SCREW 3.18	
8	028030243	2	ハネサカネ2-3	SPRING WASHER 2-3	
9	S11890001	1	ボトムレバーササエタイ	BOTTOM LEVER SUPPORT BRACKET	
10	018500822	4	アナボルト5X8	BOLT 5X8	
11	028050242	4	ハネサカネ2-5	SPRING WASHER 2-5	

H2. ボトム関係/Bottom mechanism/Unterer Mechanismus/
Mécanisme inférieur/Mecanismo del fondo

REF.NO.	CODE	Q'TY	ヒンメイ	NAME OF PARTS	RMKS
<BAS-754, 750KL>					
1	S24552001	1	ボトムプランシヤ	BOTTOM PLUNGER	
2	S24553001	1	ハリアナイタ	NEEDLE HOLE PLATE	
3	100191003	2	サラネジ2.38	SCREW 2.38	
4	107272002	4	サラネジ4.37	SCREW 4.37	

J1. 折曲ゲ関係 (特別注文部品) / Folding margin mechanism (Option parts) / Faltungsvorrichtung (Sonderzubehör) / Mécanisme de marge d'ourlet (Pièces en option) / Mecanismo de margen de plegado (Piezas a opción)

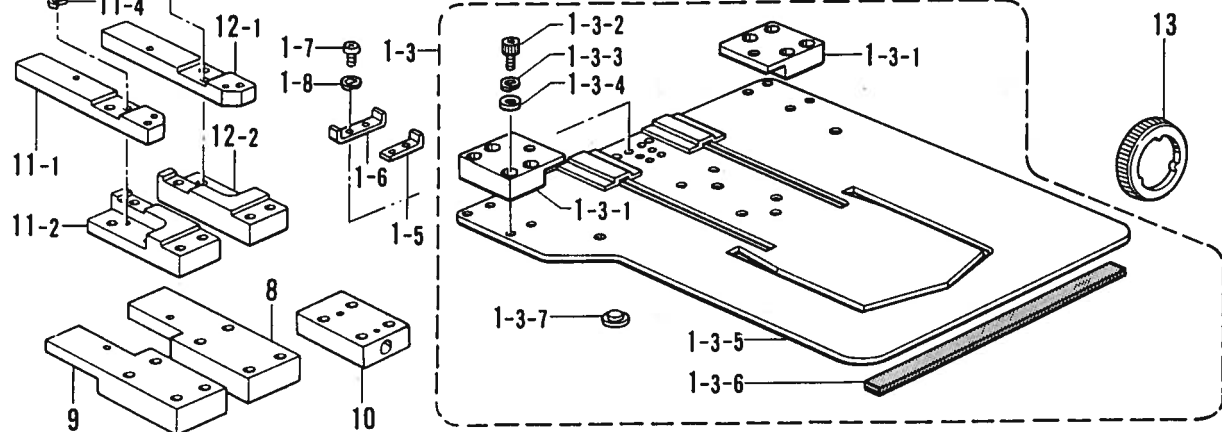
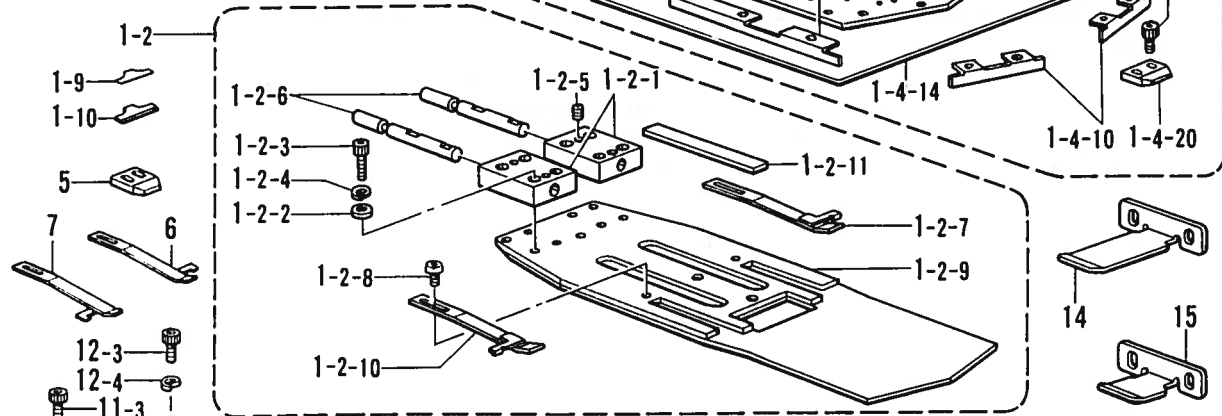
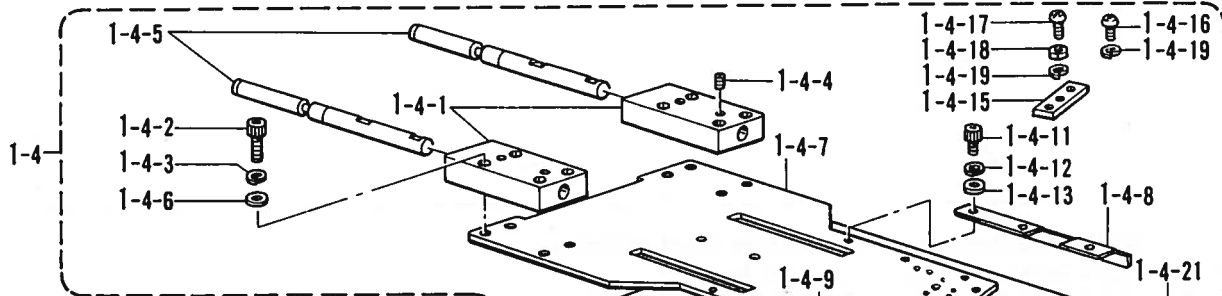
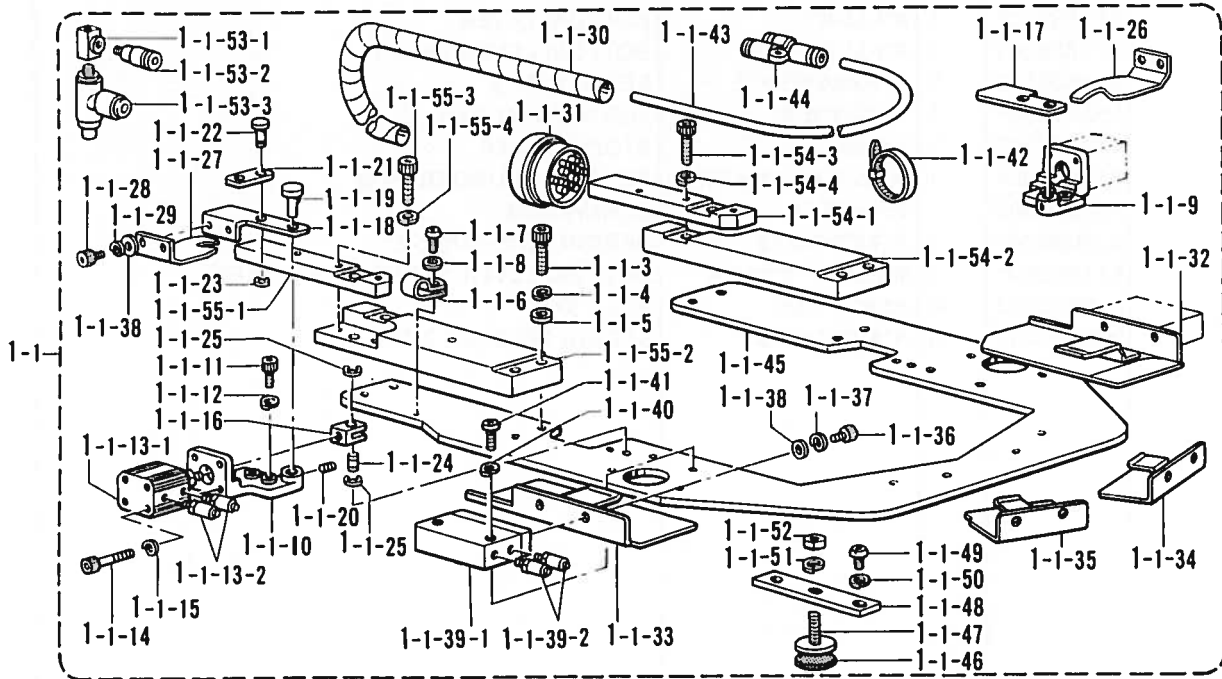

J1. 折曲ゲ関係 (特別注文部品) / Folding margin mechanism (Option parts) / Faltungsvorrichtung (Sonderzubehör) / Mécanisme de marge d'ourlet (Pièces en option) / Mecanismo de margen de plegado (Piezas a opción)

REF NO.	CODE	Q'TY	ヒンメイ	NAME OF PARTS	RMKS
1	S12283---	1	オリキクミ-3カク	FOLDING GROUP ASSEMBLY (TRIANGLE)	
1-1	S12284---	1	オリササエクミ-3カク	FOLDING CLAMP ASSEMBLY (TRIANGLE)	
1-1-3	018502522	8	アナホ"ルト5X25	BOLT 5X25	
1-1-4	028050242	8	ハ"ネサ"カ"ネ2-5	SPRING WASHER 2-5	
1-1-5	S20246001	8	ヒラサ"カ"ネタ"イ5	PLAIN WASHER 5	
1-1-6	552907000	1	コート"ホルタ"#10	CORD HOLDER (10N)	
1-1-7	062401006	1	ナヘ"コ4X10	SCREW 4X10	
1-1-8	025040233	1	ヒラサ"カ"ネチユウ4	PLAIN WASHER 4	
1-1-9	S12088009	1	レハ"ー"へ"ー"スR	LEVER BASE (R)	
1-1-10	S12089009	1	レハ"ー"へ"ー"スL	LEVER BASE (L)	
1-1-11	018401222	4	アナホ"ルト4X12	BOLT 4X12	
1-1-12	028040242	4	ハ"ネサ"カ"ネ2-4	SPRING WASHER 2-4	
1-1-13	S12090000	2	シリンタ"-12X10クミ	CYLINDER 12X10 ASSEMBLY	
1-1-13-1	S12091000	2	シリンタ"-12X10	CYLINDER 12X10	
1-1-13-2	S11433000	4	ホ-スニツプル4M5	HOSE NIPPLE 4M5	
1-1-14	S12092000	8	CQ2ホ"ルトM3X30	CQ2 BOLT M3X30	
1-1-15	028030243	8	ハ"ネサ"カ"ネ2-3	SPRING WASHER 2-3	
1-1-16	S12093001	2	ナツクル	KNUCKLE	
1-1-17	S12094001	1	ヒンシ"R	HINGE (R)	
1-1-18	S12095001	1	ヒンシ"L	HINGE (L)	
1-1-19	S12096001	2	ヒンシ"ピン	PIN	
1-1-20	014400522	2	アナクホ"ミ34X5	SET SCREW 4X5	
1-1-21	S12097001	2	タイププレート	TIE PLATE	
1-1-22	S12098001	2	ピン	PIN	
1-1-23	048050342	2	トメワE5	STOP RING E5	
1-1-24	S12099001	2	ナツクルピン	KNUCKLE PIN	
1-1-25	048050342	4	トメワE5	STOP RING E5	
1-1-26	S12475100	1	メントリイタRタイ	TUCKING BLADE (R) LARGE	
1-1-27	S12476100	1	メントリイタLタイ	TUCKING BLADE (L) LARGE	
1-1-28	018400632	4	アナホ"ルト4X6	BOLT 4X6	
1-1-29	028040242	4	ハ"ネサ"カ"ネ2-4	SPRING WASHER 2-4	
1-1-30	S12214000	1	スパイラル640L	SPIRAL 640L	
1-1-31	S12106000	1	マルチコネクタP	MULTI CONNECTOR (P)	
1-1-32	S12285---	1	オリイタR-3カク	TUCKING BLADE (R)(TRIANGLE)	
1-1-33	S12286---	1	オリイタL-3カク	TUCKING BLADE (L)(TRIANGLE)	
1-1-34	S12287---	1	オリイタRD-3カク	TUCKING BLADE (RD)(TRIANGLE)	
1-1-35	S12288---	1	オリイタLD-3カク	TUCKING BLADE (LD)(TRIANGLE)	
1-1-36	018400632	8	アナホ"ルト4X6	BOLT 4X6	
1-1-37	028040242	8	ハ"ネサ"カ"ネ2-4	SPRING WASHER 2-4	
1-1-38	158722002	12	サ"カ"ネ4.2	WASHER 4.2	
1-1-39	S12102000	4	ツインロッド"シリンタ"ークミ	TWIN ROD CYLINDER ASSEMBLY	
1-1-39-1	S12103000	4	ツインロッド"シリンタ"ー	TWIN ROD CYLINDER	
1-1-39-2	S11433000	8	ホ-スニツプル4M5	HOSE NIPPLE 4M5	
1-1-40	028040243	8	ハ"ネサ"カ"ネ2-4	SPRING WASHER 2-4	
1-1-41	062402016	8	ナヘ"コM4X20	SCREW M4X20	
1-1-42	S04159000	4	バンド"1M	BAND 1M	
1-1-43	S12205000	1	エアホ-ス4X2.5-29	AIR TUBE 4X2.5-29	
1-1-44	S12104000	4	ユニオンワイ4	UNION-Y 4	
1-1-45	S12289---	1	オリササエ-3カク	FOLDING CLAMP (TRIANGLE)	
1-1-46	S12297000	2	スポンジ"2-30	SPONGE 2X15X1200	
1-1-47	S12291001	2	アジ"ヤストネジ"	ADJUST SCREW	
1-1-48	S12294001	2	トリツケイタ(オリササエ)	FITTING PLATE (FOLDING CLAMP)	
1-1-49	062401006	4	ナヘ"コ4X10	SCREW 4X10	
1-1-50	028040243	4	ハ"ネサ"カ"ネ2-4	SPRING WASHER 2-4	
1-1-51	028060243	2	ハ"ネサ"カ"ネ2-6	SPRING WASHER 2-6	
1-1-52	021060206	2	2シユナツト6	NUT 6	
1-1-53	S15564000	1	チ- M5クミ	T-M5 ASSEMBLY	
1-1-53-1	S15563000	1	チ-M5	T-M5	
1-1-53-2	S04905000	1	ハーフユニオン	HALF UNION	
1-1-53-3	S14328000	2	シボ"リハ"ン	THROTTLE VALVE	
1-1-54	S24888001	1	コネクタブ"ロックRクミ	CONNECT BLOCK (R) ASSEMBLY	
1-1-54-1	S24460001	1	コネクタブ"ロックR-1	CONNECT BLOCK (R-1)	

J1. 折曲関係 (特別注文部品) / Folding margin mechanism (Option parts) / Faltungsvorrichtung (Sonderzubehör) / Mécanisme de marge d'ourlet (Pièces en option) / Mecanismo de margen de plegado (Piezas a opción)

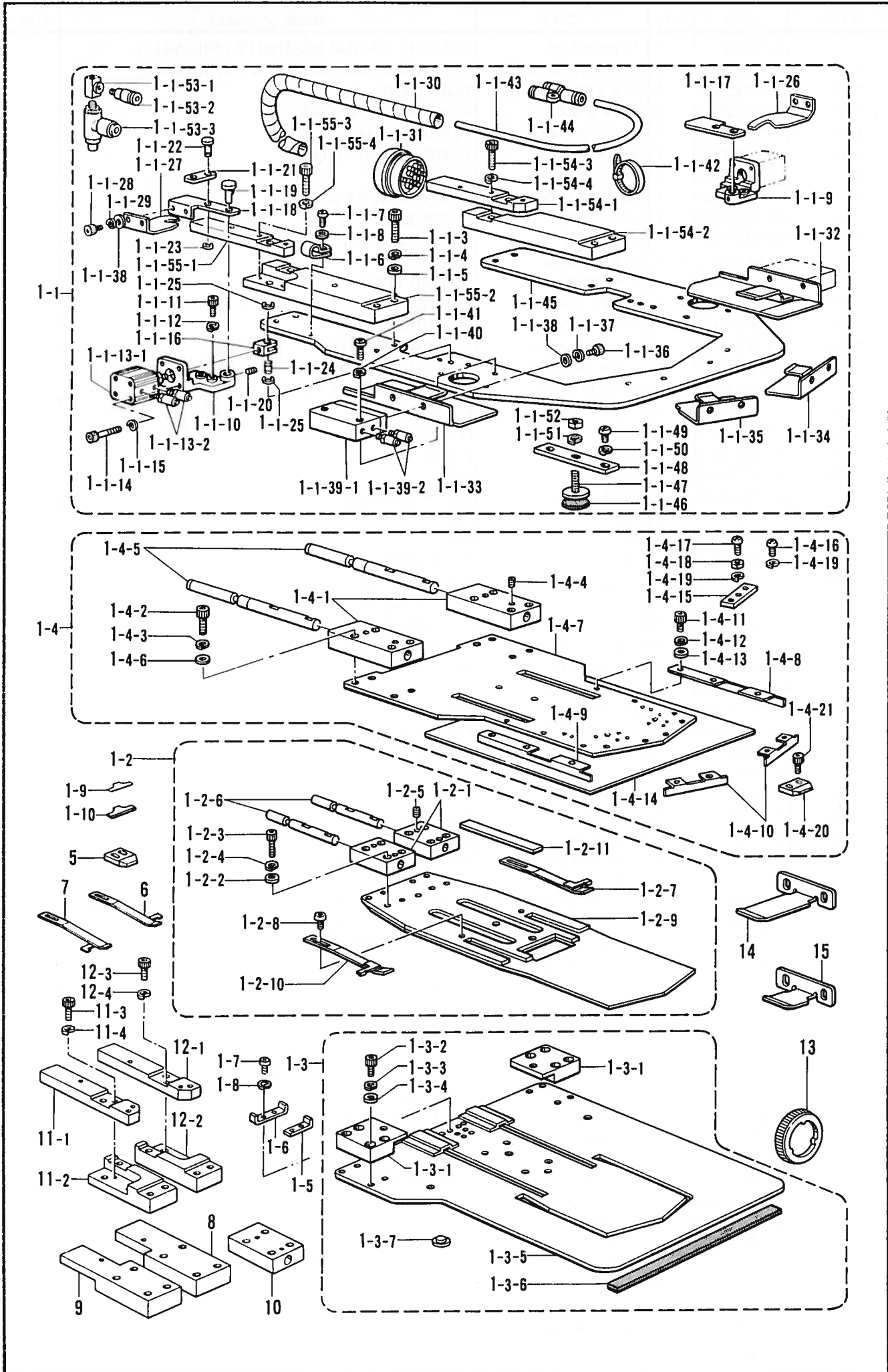

J1. 折曲ゲ関係 (特別注文部品) / Folding margin mechanism (Option parts) / Faltungsvorrichtung (Sonderzubehör) / Mécanisme de marge d'ourlet (Pièces en option) / Mecanismo de margen de plegado (Piezas a opción)

REF. NO.	CODE	Q'TY	ヒンメイ	NAME OF PARTS	RMKS
1-1-54-2	S24461001	1	コネクタブ"ロックR-2	CONNECT BLOCK (R-2)	
1-1-54-3	018502022	2	アナホ"ルト5X20	BOLT 5X20	
1-1-54-4	028050242	2	ハ"ネサ"カ"ネ2-5	SPRING WASHER 2-5	
1-1-55	S24889001	1	コネクタブ"ロックLクミ	CONNECT BLOCK (L) ASSEMBLY	
1-1-55-1	S24458001	1	コネクタブ"ロックL-1	CONNECT BLOCK (L-1)	
1-1-55-2	S24459001	1	コネクタブ"ロックL-2	CONNECT BLOCK (L-2)	
1-1-55-3	018502022	2	アナホ"ルト5X20	BOLT 5X20	
1-1-55-4	028050242	2	ハ"ネサ"カ"ネ2-5	SPRING WASHER 2-5	
1-2	S12292---	1	ゲ"ー"シ"クミ-3カク	CENTER BLADE ASSEMBLY (TRIANGLE)	
1-2-1	S12107001	2	コネクタブ"ロック(GAGE)	CONNECT BLOCK (CENTER BLADE)(GAGE)	
1-2-2	158722002	8	サ"カ"ネ4.2	WASHER 4.2	
1-2-3	018402032	8	アナホ"ルト4X20	BOLT 4X20	
1-2-4	028040242	8	ハ"ネサ"カ"ネ2-4	SPRING WASHER 2-4	
1-2-5	014500522	4	ア"ナ"ト"メ"ネ"シ"5"ク"ホ"ミ	SET SCREW 5	
1-2-6	S12108001	2	コネクタブ"ピン(ゲ"ー"シ")	PIN (CENTER BLADE)(GAGE)	
1-2-7	S12109100	1	イ"タ"ハ"ネR	PLATE SPRING (R)	
1-2-8	060300414	4	ハ"イ"ン"ト"3X4	SCREW 3X4	
1-2-9	S12293---	1	ゲ"ー"シ"クミ-3カク	CENTER BLADE (TRIANGLE)	
1-2-10	S12105100	1	イ"タ"ハ"ネL	PLATE SPRING (L)	
1-2-11	S12278000	2	ウ"ケ"イ"タ(ゲ"ー"シ")	SUPPORT PLATE (CENTER BLADE)	
1-3	S12295---	1	オ"サ"エ"ク"ミ-3カク	SEWING CLAMP ASSEMBLY (TRIANGLE)	
1-3-1	S12110001	2	コネクタブ"ロック(オ"サ"エ)	CONNECT BLOCK (PRESSER)	
1-3-2	018401022	8	アナホ"ルト4X10	BOLT 4X10	
1-3-3	028040242	8	ハ"ネサ"カ"ネ2-4	SPRING WASHER 2-4	
1-3-4	158722002	8	サ"カ"ネ4.2	WASHER 4.2	
1-3-5	S12296---	1	オ"サ"エ-3カク	SEWING CLAMP (TRIANGLE)	
1-3-6	S12298000	2	フ"ォ"ム3X15X1000	FORM 3X15X1000	
1-3-7	S12279000	6	ウ"ケ"イ"タ(オ"サ"エ)	SUPPORT PLATE (PRESSER)	
1-4	S12299---	1	ナ"カ"オ"サ"エ"ク"ミ-3カク	INNER CLAMP ASSEMBLY (TRIANGLE)	
1-4-1	S12113001	2	コネクタブ"ロック(ナ"カ)	CONNECT BLOCK (INNER)	
1-4-2	018502522	8	アナホ"ルト5X25	BOLT 5X25	
1-4-3	028050242	8	ハ"ネサ"カ"ネ2-5	SPRING WASHER 2-5	
1-4-4	014500522	4	ア"ナ"ト"メ"ネ"シ"5"ク"ホ"ミ	SET SCREW 5	
1-4-5	S12114001	2	コネクタブ"ピン(ナ"カ)	PIN (INNER)	
1-4-6	S20246001	8	ヒ"ラ"サ"カ"ネ"タ"イ5	PLAIN WASHER 5	
1-4-7	S12300---	1	ナ"カ"オ"サ"エ-3カク	INNER CLAMP (TRIANGLE)	
1-4-8	S12301---	1	ナ"カ"オ"サ"エ"ウ"エ1-3カク	INNER CLAMP BLADE-1 (TRIANGLE)	
1-4-9	S12302---	1	ナ"カ"オ"サ"エ"ウ"エ2-3カク	INNER CLAMP BLADE-2 (TRIANGLE)	
1-4-10	S12303---	2	ナ"カ"オ"サ"エ"ウ"エ3-3カク	INNER CLAMP BLADE-3 (TRIANGLE)	
1-4-11	018300532	10	アナホ"ルト3X5	BOLT 3X5	
1-4-12	028030242	10	ハ"ネサ"カ"ネ2-3	SPRING WASHER 2-3	
1-4-13	025030232	10	ヒ"ラ"サ"カ"ネ"チ"ユ"ウ3	PLAIN WASHER 3	
1-4-14	S12117000	1	フ"ォ"ム2X200X200	FORM 2X200X200	
1-4-15	S12485001	2	ト"リ"ツ"ケ"イ"タ(ナ"カ"オ"サ"エ)	FITTING PLATE (INNER CLAMP)	
1-4-16	062400806	4	ナ"ヘ"コ4X8	SCREW M4X8	
1-4-17	062401416	2	ナ"ヘ"コ4X14	SCREW 4X14	
1-4-18	021400103	2	ナ"ツ"ト1シユ4	NUT 4	
1-4-19	028040243	6	ハ"ネサ"カ"ネ2-4	SPRING WASHER 2-4	
1-4-20	S12487000	4	オ"リ"イ"タ"ウ"ケ(ナ"カ"オ"サ"エ)	FOLDING PLATE SUPPORT (INNER CLAMP)	
1-4-21	018300532	8	アナホ"ルト3X5	BOLT 3X5	
1-5	S12111001	3	ス"リ"ツ"トC	SLIT (C)	
1-6	S12112001	3	ス"リ"ツ"トD	SLIT (D)	
1-7	062300502	6	ナ"ヘ"コ3X5	SCREW 3X5	
1-8	028030242	6	ハ"ネサ"カ"ネ2-3	SPRING WASHER 2-3	
1-9	S16514000	2	ス"ペ"ー"サ0.05	SPACER 0.05	
1-10	S16513000	2	ス"ペ"ー"サ0.1	SPACER 0.1	
5	S12494000	1	オ"リ"イ"タ"ウ"ケ"シ"ョ"ウ	FOLDING PLATE SUPPORT (SMALL)	
6	S15565100	1	イ"タ"ハ"ネR0.8	PLATE SPRING (R) 0.8	
7	S15566100	1	イ"タ"ハ"ネL0.8	PLATE SPRING (L) 0.8	
8	S21121001	1	コネクタブ"ロックSSR	CONNECT BLOCK (SSR)	
9	S21122001	1	コネクタブ"ロックSSL	CONNECT BLOCK (SSL)	
10	S21123001	2	コネクタブ"ロックS	CONNECT BLOCK (S)	

J1. 折曲ゲ関係 (特別注文部品) / Folding margin mechanism (Option parts) / Faltungsvorrichtung (Sonderzubehör) / Mécanisme de marge d'ourlet (Pièces en option) / Mecanismo de margen de plegado (Piezas a opción)

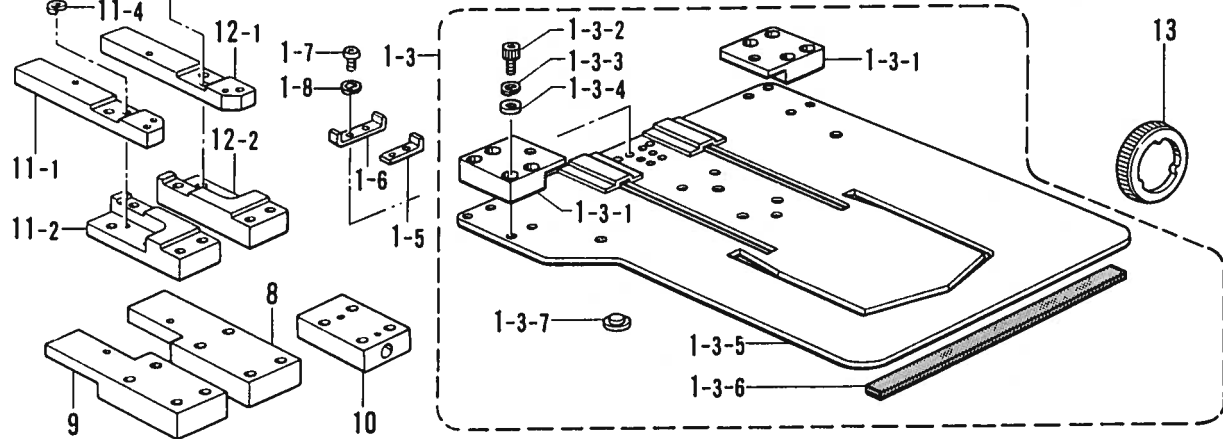
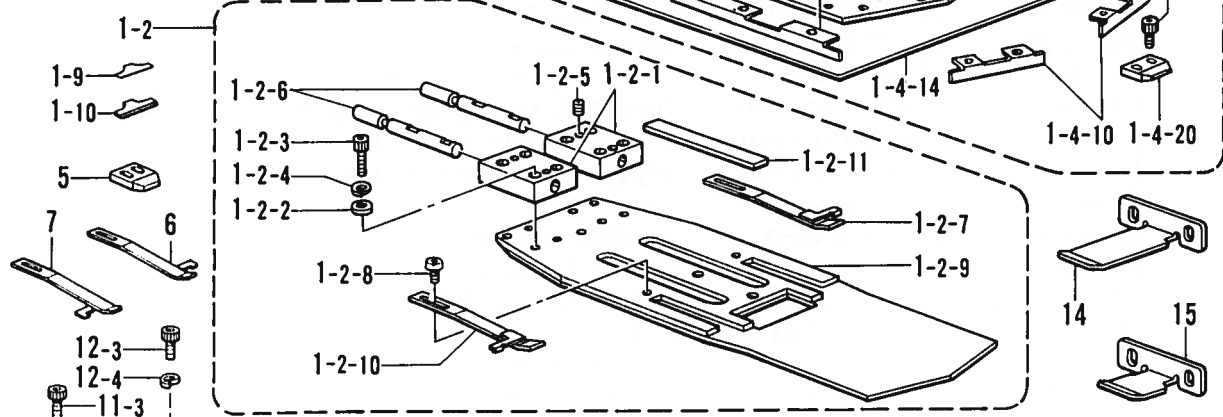
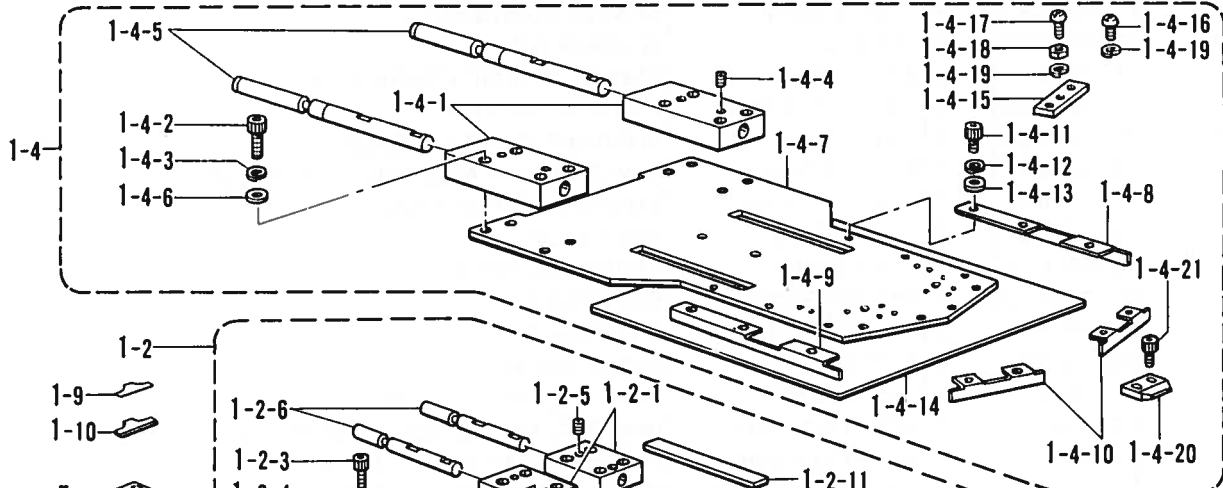
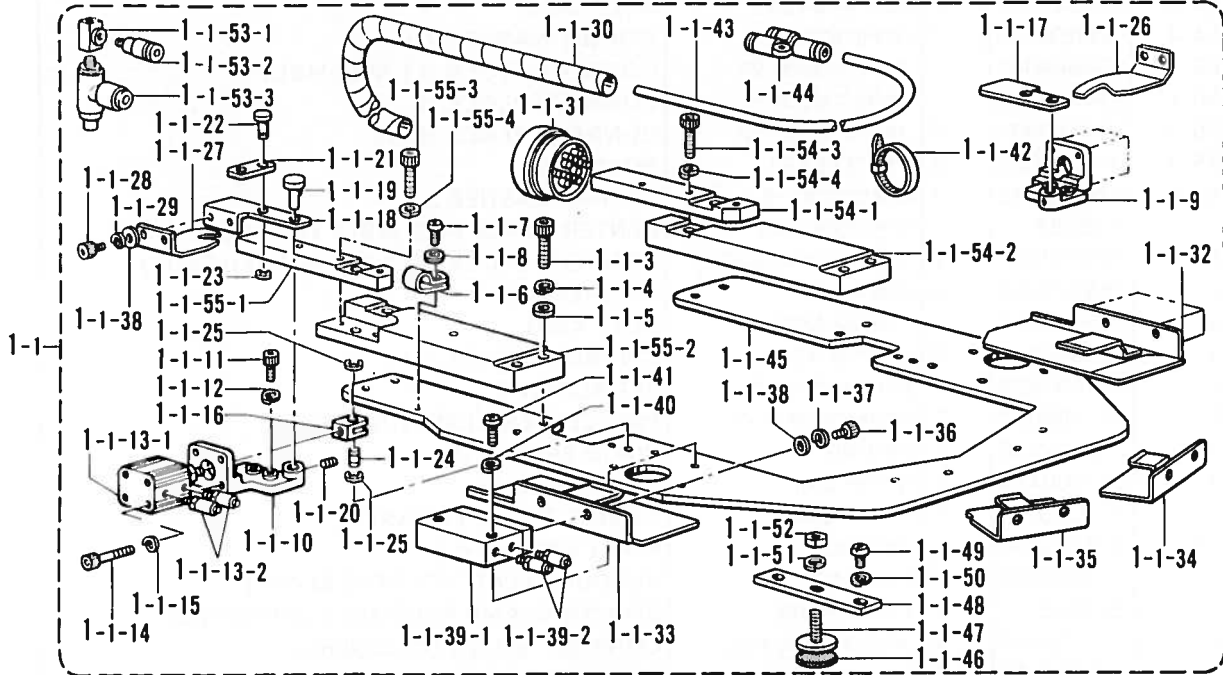

J1. 折曲ゲ関係 (特別注文部品) / Folding margin mechanism (Option parts) / Faltungsvorrichtung (Sonderzubehör) /
 Mécanisme de marge d'ourlet (Pièces en option) / Mecanismo de margen de plegado (Piezas a opción)

REF. NO.	CODE	Q'TY	品名	NAME OF PARTS	RMKS
11	S24887001	1	コネクタブロックSLクミ	CONNECT BLOCK (SL) ASSEMBLY	
11-1	S24454001	1	コネクタブロックSL-1	CONNECT BLOCK (SL-1)	
11-2	S24455001	1	コネクタブロックSL-2	CONNECT BLOCK (SL-2)	
11-3	018502022	2	アナボルト5X20	BOLT 5X20	
11-4	028050242	2	ハネサガネ2-5	SPRING WASHER 2-5	
12	S24886001	1	コネクタブロックSRクミ	CONNECT BLOCK (SR) ASSEMBLY	
12-1	S24456001	1	コネクタブロックSR-1	CONNECT BLOCK (SR-1)	
12-2	S24457001	1	コネクタブロックSR-2	CONNECT BLOCK (SR-2)	
12-3	018502022	2	アナボルト5X20	BOLT 5X20	
12-4	028050242	2	ハネサガネ2-5	SPRING WASHER 2-5	
13	S24828000	1	クランプリング12	CLAMRING 12	
14	S24891000	1	オリイタウIL	FOLDING PLATE UPPER (L)	
15	S24892000	1	オリイタウIS	FOLDING PLATE UPPER (S)	

J2. 折曲ゲ関係 (特別注文部品) / Folding margin mechanism (Option parts) / Faltungsvorrichtung (Sonderzubehör) / Mécanisme de marge d'ourlet (Pièces en option) / Mecanismo de margen de plegado (Piezas a opción)

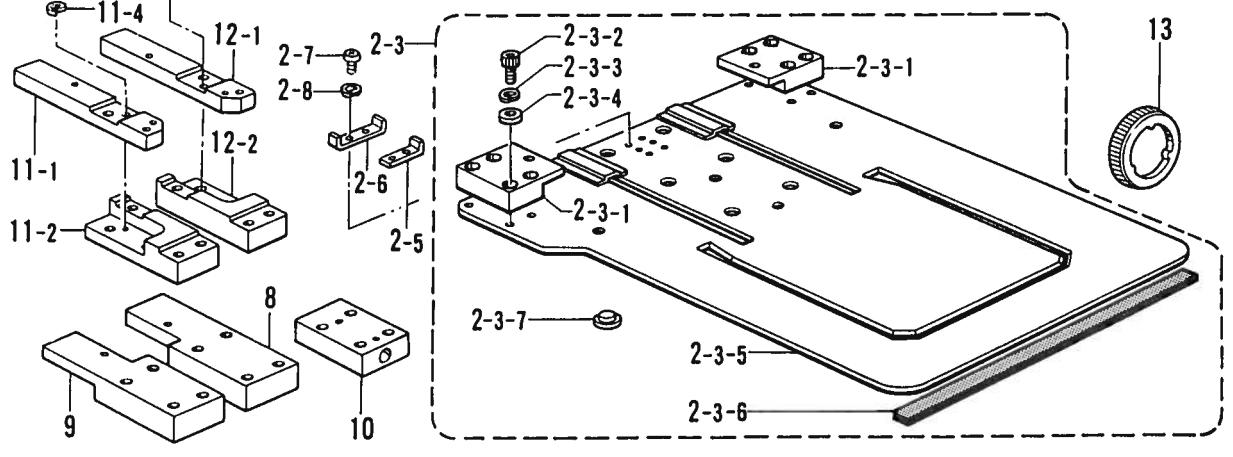
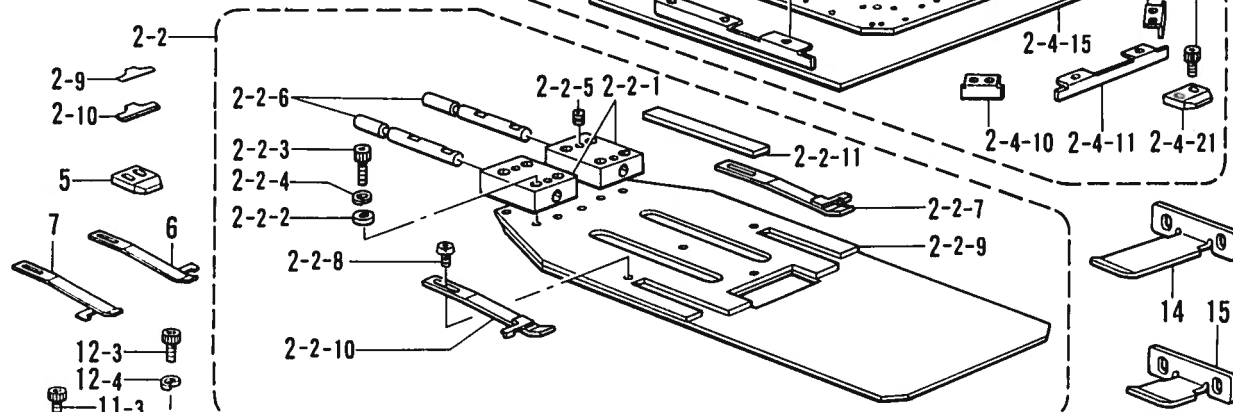
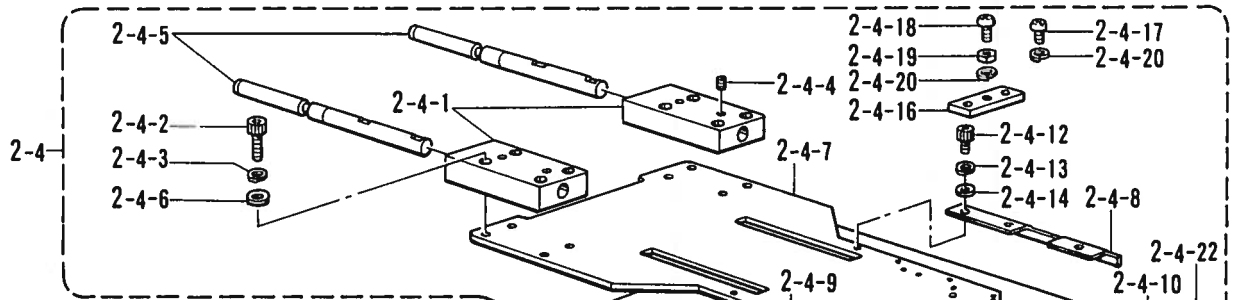
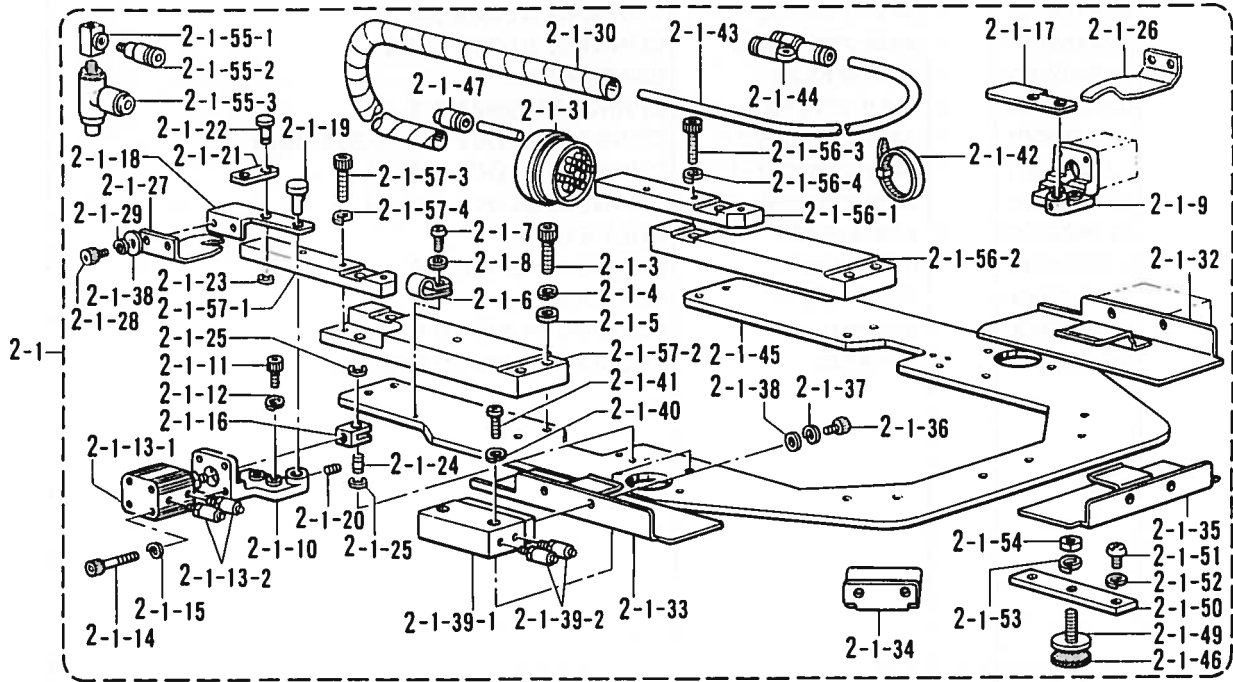

J2. 折曲ゲ関係 (特別注文部品) / Folding margin mechanism (Option parts) / Faltungsvorrichtung (Sonderzubehör) / Mécanisme de marge d'ourlet (Pièces en option) / Mecanismo de margen de plegado (Piezas a opción)

REF.NO	CODE	Q'TY	ヒンメイ	NAME OF PARTS	RMKS
2	S12305---	1	オリキクミ-5カク	FOLDING GROUP ASSEMBLY (MITER)	
2-1	S12306---	1	オリササエクミ-5カク	FOLDING CLAMP ASSEMBLY (MITER)	
2-1-3	018502522	8	アナホ"ルト5X25	BOLT 5X25	
2-1-4	028050242	8	ハ"ネサ"カ"ネ2-5	SPRING WASHER 2-5	
2-1-5	S20246001	8	ヒラサ"カ"ネタ"イ5	PLAIN WASHER 5	
2-1-6	552907000	1	コート"ホルタ"#10	CORD HOLDER (10N)	
2-1-7	062401006	1	ナヘ"コ4X10	SCREW 4X10	
2-1-8	025040233	1	ヒラサ"カ"ネチユウ4	PLAIN WASHER 4	
2-1-9	S12088009	1	レハ"ー"へ"ースR	LEVER BASE (R)	
2-1-10	S12089009	1	レハ"ー"へ"ースL	LEVER BASE (L)	
2-1-11	018401222	4	アナホ"ルト4X12	BOLT 4X12	
2-1-12	028040242	4	ハ"ネサ"カ"ネ2-4	SPRING WASHER 2-4	
2-1-13	S12090000	2	シリンタ"-12X10クミ	CYLINDER 12X10 ASSEMBLY	
2-1-13-1	S12091000	2	シリンタ"-12X10	CYLINDER 12X10	
2-1-13-2	S11433000	4	ホースニツプ"ル4M5	HOSE NIPPLE 4M5	
2-1-14	S12092000	8	CQ2ホ"ルトM3X30	CQ2 BOLT M3X30	
2-1-15	028030243	8	ハ"ネサ"カ"ネ2-3	SPRING WASHER 2-3	
2-1-16	S12093001	2	ナツクル	KNUCKLE	
2-1-17	S12094001	1	ヒンジ"R	HINGE (R)	
2-1-18	S12095001	1	ヒンジ"L	HINGE (L)	
2-1-19	S12096001	2	ヒンジ"ピン	PIN	
2-1-20	014400522	2	アナクホ"ミ4X5	SET SCREW 4X5	
2-1-21	S12097001	2	タイフ"レート	TIE PLATE	
2-1-22	S12098001	2	ピン	PIN	
2-1-23	048050342	2	トメフE5	STOP RING E5	
2-1-24	S12099001	2	ナツクルピン	KNUCKLE PIN	
2-1-25	048050342	4	トメフE5	STOP RING E5	
2-1-26	S12475100	1	メントリイタR"タ"イ	TUCKING BLADE (R) LARGE	
2-1-27	S12476100	1	メントリイタL"タ"イ	TUCKING BLADE (L) LARGE	
2-1-28	018400632	4	アナホ"ルト4X6	BOLT 4X6	
2-1-29	028040242	4	ハ"ネサ"カ"ネ2-4	SPRING WASHER 2-4	
2-1-30	S12214000	1	スパ"イラル640L	SPIRAL 640L	
2-1-31	S12106000	1	マルチコネクタP	MULTI CONNECTOR (P)	
2-1-32	S12307---	1	オリイタR-5カク	TUCKING BLADE (R) (MITER)	
2-1-33	S12308---	1	オリイタL-5カク	TUCKING BLADE (L) (MITER)	
2-1-34	S12309---	2	オリイタS-5カク	TUCKING BLADE (S) (MITER)	
2-1-35	S12310---	1	オリイタM-5カク	TUCKING BLADE (M) (MITER)	
2-1-36	018400632	10	アナホ"ルト4X6	BOLT 4X6	
2-1-37	028040242	10	ハ"ネサ"カ"ネ2-4	SPRING WASHER 2-4	
2-1-38	158722002	14	サ"カ"ネ4.2	WASHER 4.2	
2-1-39	S12102000	5	ツインロツト"シリンタ"-ークミ	TWIN ROD CYLINDER ASSEMBLY	
2-1-39-1	S12103000	5	ツインロツト"シリンタ"-	TWIN ROD CYLINDER	
2-1-39-2	S11433000	10	ホースニツプ"ル4M5	HOSE NIPPLE 4M5	
2-1-40	028040243	10	ハ"ネサ"カ"ネ2-4	SPRING WASHER 2-4	
2-1-41	062402016	10	ナヘ"コM4X20	SCREW M4X20	
2-1-42	S04159000	4	ハ"ント"1M	BAND 1M	
2-1-43	S12205000	1	エアホース4X2.5-29	AIR TUBE 4X2.5-29	
2-1-44	S12104000	8	ユニオンフイ4	UNION-Y 4	
2-1-45	S12311---	1	オリササエ-5カク	FOLDING CLAMP (MITER)	
2-1-46	S12297000	2	スポンジ"2-30	SPONGE 2X15X1200	
2-1-47	S19555000	2	キャツプ"4	CAP 4	
2-1-49	S12291001	2	アジ"ヤストネシ"	ADJUST SCREW	
2-1-50	S12294001	2	トリツケイタ(オリササエ)	FITTING PLATE (FOLDING CLAMP)	
2-1-51	062401006	4	ナヘ"コ4X10	SCREW 4X10	
2-1-52	028040243	4	ハ"ネサ"カ"ネ2-4	SPRING WASHER 2-4	
2-1-53	028060243	2	ハ"ネサ"カ"ネ2-6	SPRING WASHER 2-6	
2-1-54	021060206	2	2シユナツト6	NUT 6	
2-1-55	S15564000	1	チ-M5クミ	T-M5 ASSEMBLY	
2-1-55-1	S15563000	1	チ-M5	T-M5	
2-1-55-2	S04905000	1	ハーフユニオン	HALF UNION	
2-1-55-3	S14328000	2	シボ"リハ"ン	THROTTLE VALVE	
2-1-56	S24888001	1	コネクト"ブ"ロツクRクミ	CONNECT BLOCK (R) ASSEMBLY	

J2. 折曲ゲ関係 (特別注文部品) / Folding margin mechanism (Option parts) / Faltungsvorrichtung (Sonderzubehör) / Mécanisme de marge d'ourlet (Pièces en option) / Mecanismo de margen de plegado (Piezas a opción)

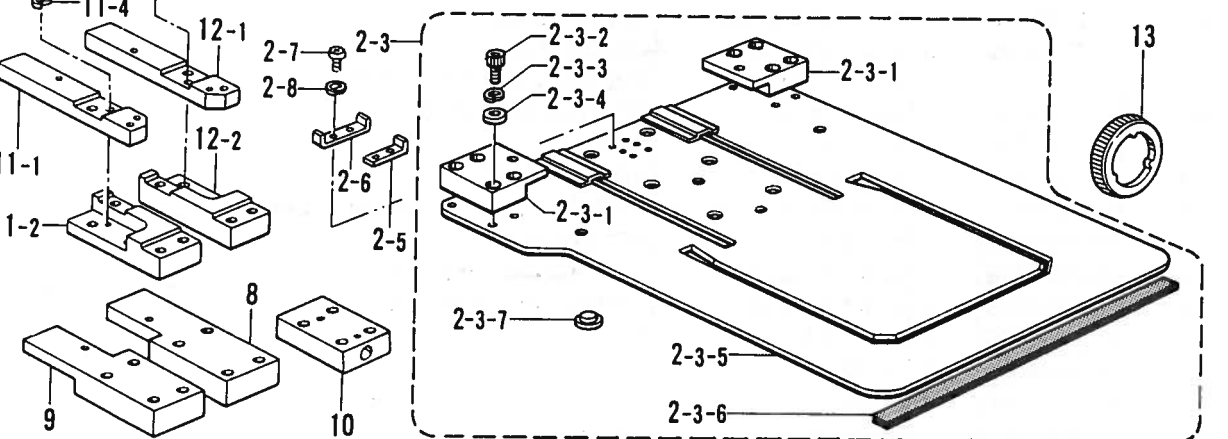
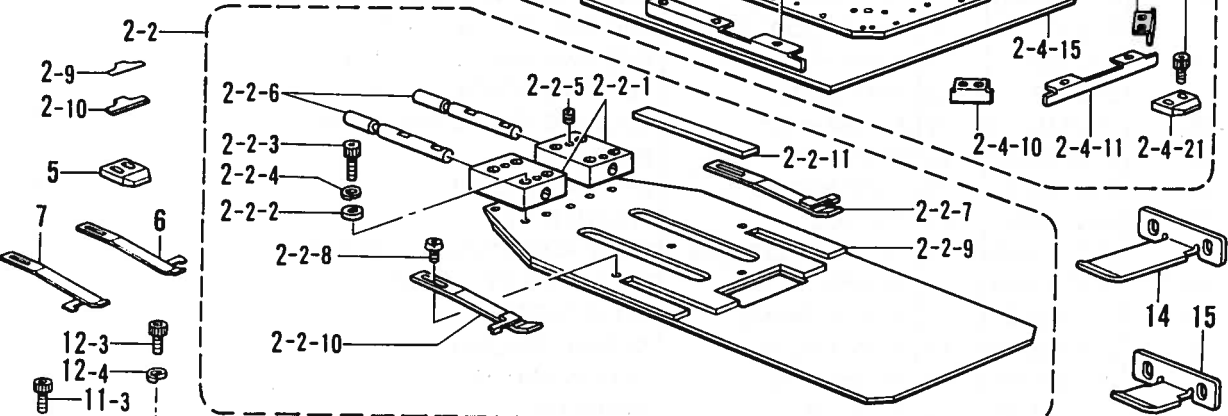
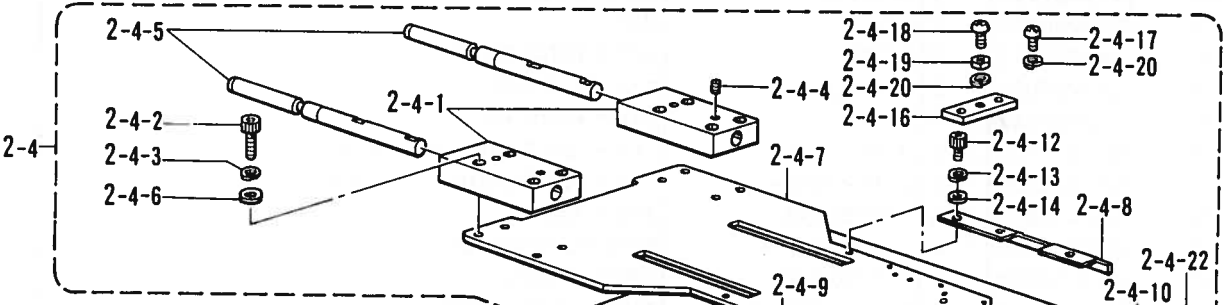
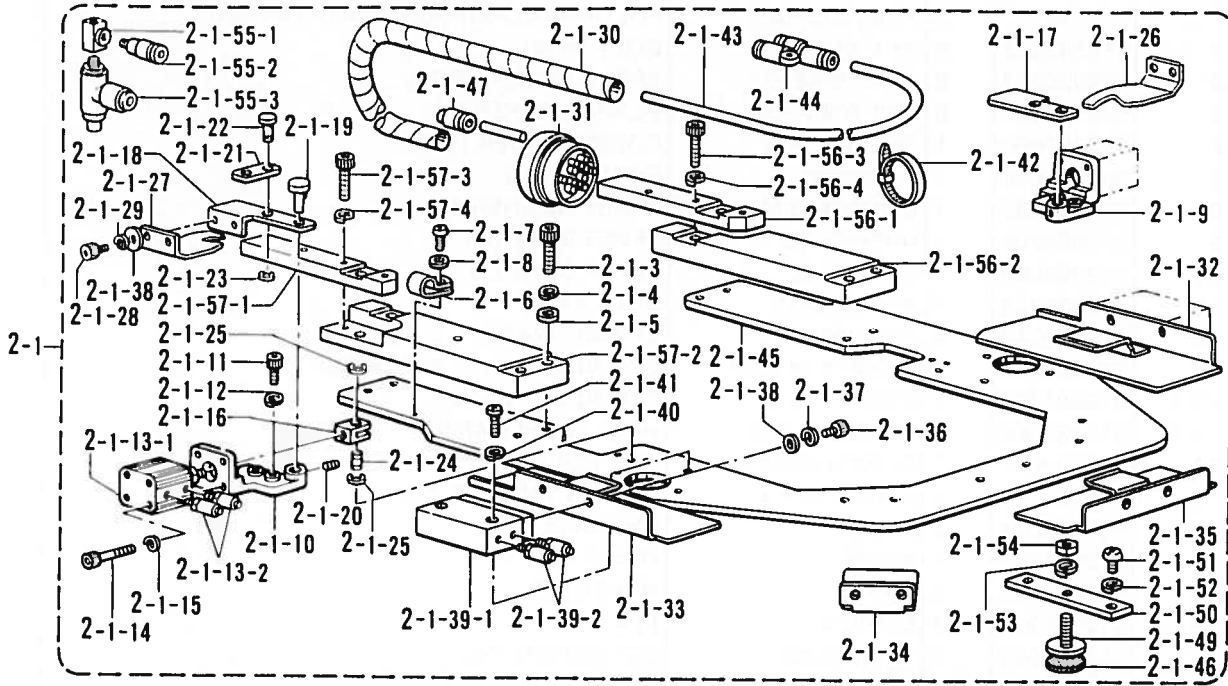

J2. 折曲ケ関係 (特別注文部品) / Folding margin mechanism (Option parts) / Faltungsvorrichtung (Sonderzubehör) / Mécanisme de marge d'ourlet (Pièces en option) / Mecanismo de margen de plegado (Piezas a opción)

REF.NO.	CODE	Q'TY	ヒンメイ	NAME OF PARTS	RMKS
2-1-56-1	S24460001	1	コネクタブ"ロックR-1	CONNECT BLOCK (R-1)	
2-1-56-2	S24461001	1	コネクタブ"ロックR-2	CONNECT BLOCK (R-2)	
2-1-56-3	018502022	2	アナホ"ルト5X20	BOLT 5X20	
2-1-56-4	028050242	2	ハ"ネサ"カ"ネ2-5	SPRING WASHER 2-5	
2-1-57	S24889001	1	コネクタブ"ロックLクミ	CONNECT BLOCK (L) ASSEMBLY	
2-1-57-1	S24458001	1	コネクタブ"ロックL-1	CONNECT BLOCK (L-1)	
2-1-57-2	S24459001	1	コネクタブ"ロックL-2	CONNECT BLOCK (L-2)	
2-1-57-3	018502022	2	アナホ"ルト5X20	BOLT 5X20	
2-1-57-4	028050242	2	ハ"ネサ"カ"ネ2-5	SPRING WASHER 2-5	
2-2	S12312---	1	ケ"ー"ジ"クミ-5カク	CENTER BLADE ASSEMBLY (MITER)	
2-2-1	S12107001	2	コネクタブ"ロック(GAGE)	CONNECT BLOCK (CENTER BLADE)(GAGE)	
2-2-2	158722002	8	サ"カ"ネ4.2	WASHER 4.2	
2-2-3	018402032	8	アナホ"ルト4X20	BOLT 4X20	
2-2-4	028040242	8	ハ"ネサ"カ"ネ2-4	SPRING WASHER 2-4	
2-2-5	014500522	4	ア"ナ"ト"メ"ネ"シ"5"ク"ホ"ミ	SET SCREW 5	
2-2-6	S12108001	2	コネクタブ"ピン(ケ"ー"ジ")	PIN (CENTER BLADE)(GAGE)	
2-2-7	S12109100	1	イ"タ"ハ"ネ"R	PLATE SPRING (R)	
2-2-8	060300414	4	ハ"イ"ン"ト"3"X"4	SCREW 3X4	
2-2-9	S12313---	1	ケ"ー"ジ"-5カク	CENTER BLADE (MITER)	
2-2-10	S12105100	1	イ"タ"ハ"ネ"L	PLATE SPRING (L)	
2-2-11	S12278000	2	ウ"ケ"イ"タ"(ケ"ー"ジ")	SUPPORT PLATE (CENTER BLADE)	
2-3	S12314---	1	オ"サ"エ"ク"ミ"-5カク	SEWING CLAMP ASSEMBLY (MITER)	
2-3-1	S12110001	2	コネクタブ"ロック(オ"サ"エ)	CONNECT BLOCK (PRESSER)	
2-3-2	018401022	8	アナホ"ルト4X10	BOLT 4X10	
2-3-3	028040242	8	ハ"ネサ"カ"ネ2-4	SPRING WASHER 2-4	
2-3-4	158722002	8	サ"カ"ネ4.2	WASHER 4.2	
2-3-5	S12315---	1	オ"サ"エ"-5カク	SEWING CLAMP (MITER)	
2-3-6	S12298000	2	フ"ォ"ー"ム"3"X"15"X"1000	FORM 3X15X1000	
2-3-7	S12279000	6	ウ"ケ"イ"タ"(オ"サ"エ)	SUPPORT PLATE (PRESSER)	
2-4	S12316---	1	ナ"カ"オ"サ"エ"ク"ミ"-5カク	INNER CLAMP ASSEMBLY (MITER)	
2-4-1	S12113001	2	コネクタブ"ロック(ナ"カ)	CONNECT BLOCK (INNER)	
2-4-2	018502522	8	アナホ"ルト5X25	BOLT 5X25	
2-4-3	028050242	8	ハ"ネサ"カ"ネ2-5	SPRING WASHER 2-5	
2-4-4	014500522	4	ア"ナ"ト"メ"ネ"シ"5"ク"ホ"ミ	SET SCREW 5	
2-4-5	S12114001	2	コネクタブ"ピン(ナ"カ)	PIN (INNER)	
2-4-6	S20246001	8	ヒ"ラ"サ"カ"ネ"タ"イ"5	PLAIN WASHER 5	
2-4-7	S12317---	1	ナ"カ"オ"サ"エ"-5カク	INNER CLAMP (MITER)	
2-4-8	S12318---	1	ナ"カ"オ"サ"エ"ウ"エ"1"-5カク	INNER CLAMP BLADE 1 (MITER)	
2-4-9	S12319---	1	ナ"カ"オ"サ"エ"ウ"エ"2"-5カク	INNER CLAMP BLADE 2 (MITER)	
2-4-10	S12320---	2	ナ"カ"オ"サ"エ"ウ"エ"3"-5カク	INNER CLAMP BLADE 3 (MITER)	
2-4-11	S12321---	1	ナ"カ"オ"サ"エ"ウ"エ"4"-5カク	INNER CLAMP BLADE 4 (MITER)	
2-4-12	018300532	12	アナホ"ルト3X5	BOLT 3X5	
2-4-13	028030242	12	ハ"ネサ"カ"ネ2-3	SPRING WASHER 2-3	
2-4-14	025030232	12	ヒ"ラ"サ"カ"ネ"チ"ユ"3	PLAIN WASHER 3	
2-4-15	S12117000	1	フ"ォ"ー"ム"2"X"200"X"200	FORM 2X200X200	
2-4-16	S12485001	2	ト"リ"ツ"ケ"イ"タ"(ナ"カ"オ"サ"エ)	FITTING PLATE (INNER CLAMP)	
2-4-17	062400806	4	ナ"ハ"コ"4"X"8	SCREW M4X8	
2-4-18	062401416	2	ナ"ハ"コ"4"X"14	SCREW 4X14	
2-4-19	021400103	2	ナ"ツ"ト"1"シ"ユ"4	NUT 4	
2-4-20	028040243	6	ハ"ネサ"カ"ネ2-4	SPRING WASHER 2-4	
2-4-21	S12487000	3	オ"リ"イ"タ"ウ"ケ"(ナ"カ"オ"サ"エ)	FOLDING PLATE SUPPORT (INNER CLAMP)	
2-4-22	018300532	6	アナホ"ルト3X5	BOLT 3X5	
2-5	S12111001	3	ス"リ"ツ"ト"C	SLIT (C)	
2-6	S12112001	3	ス"リ"ツ"ト"D	SLIT (D)	
2-7	062300502	6	ナ"ハ"コ"3"X"5	SCREW 3X5	
2-8	028030242	6	ハ"ネサ"カ"ネ2-3	SPRING WASHER 2-3	
2-9	S16514000	2	ス"ペ"ー"サ"0.05	SPACER 0.05	
2-10	S16513000	2	ス"ペ"ー"サ"0.1	SPACER 0.1	
5	S12494000	1	オ"リ"イ"タ"ウ"ケ"シ"ョ"ウ	FOLDING PLATE SUPPORT (SMALL)	
6	S15565100	1	イ"タ"ハ"ネ"R0.8	PLATE SPRING (R) 0.8	
7	S15566100	1	イ"タ"ハ"ネ"L0.8	PLATE SPRING (L) 0.8	
8	S21121001	1	コネクタブ"ロックSSR	CONNECT BLOCK (SSR)	

J2. 折曲ケ関係 (特別注文部品) / Folding margin mechanism (Option parts) / Faltungsvorrichtung (Sonderzubehör) / Mécanisme de marge d'ourlet (Pièces en option) / Mecanismo de margen de plegado (Piezas a opción)

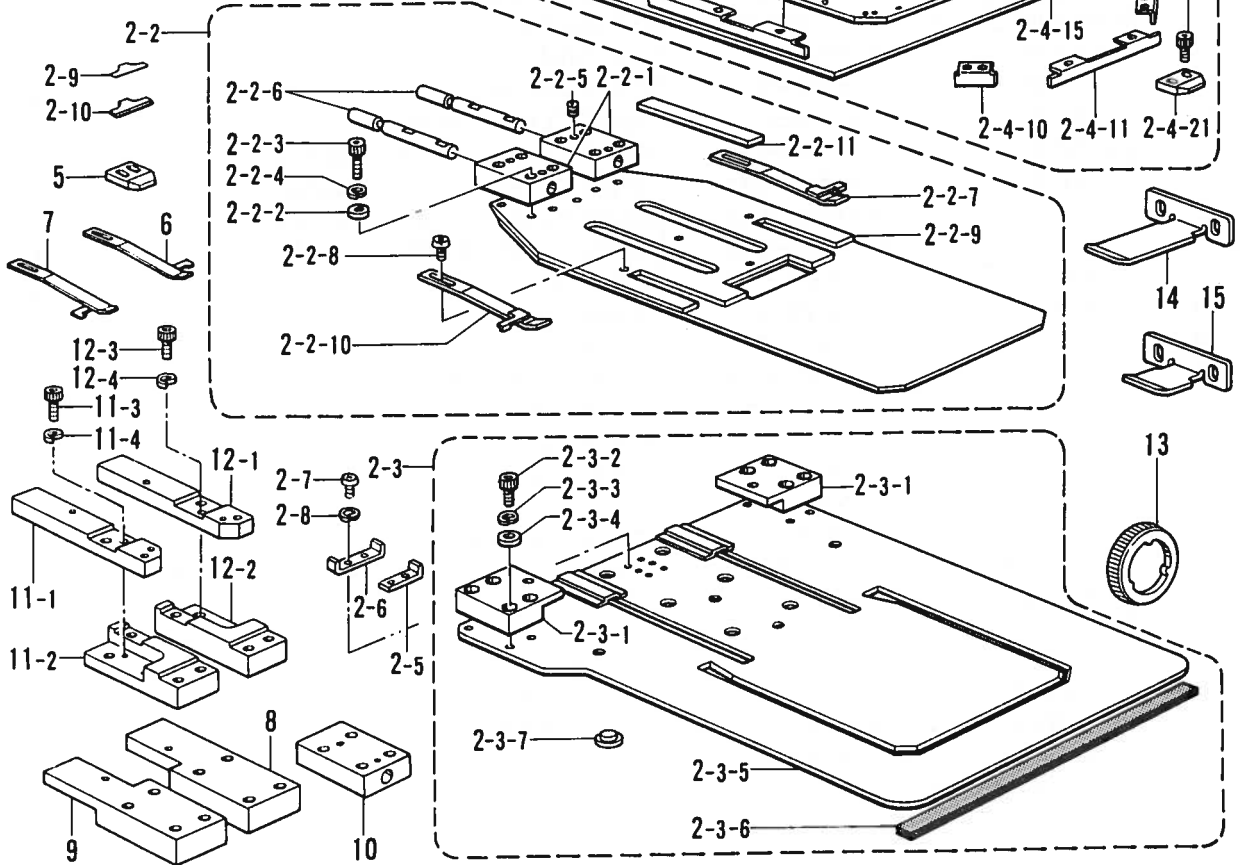
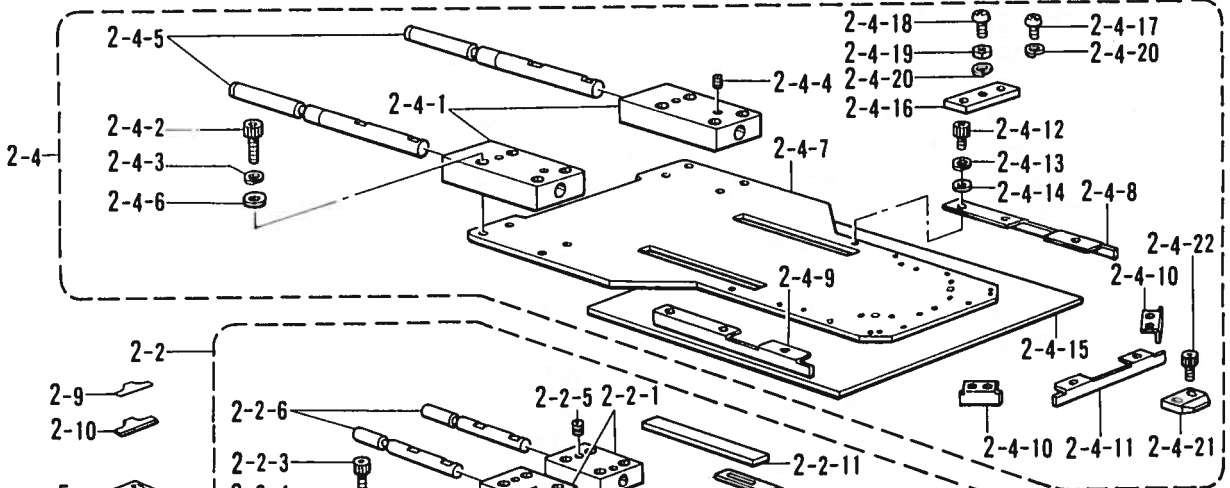
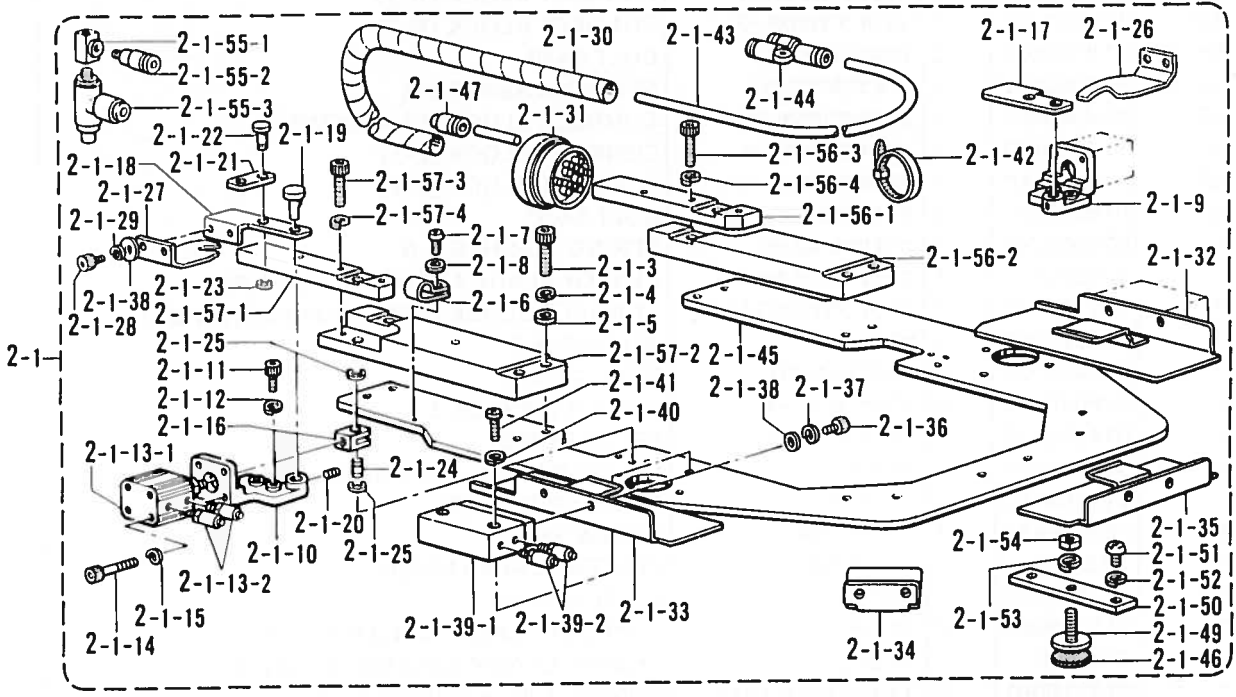

J2. 折曲ゲ関係 (特別注文部品) / Folding margin mechanism (Option parts) / Faltungsvorrichtung (Sonderzubehör) /
 Mécanisme de marge d'ourlet (Pièces en option) / Mecanismo de margen de plegado (Piezas a opción)

REF. NO.	CODE	Q'TY	ヒンメイ	NAME OF PARTS	RMKS
9	S21122001	1	コネクタブロックSSL	CONNECT BLOCK (SSL)	
10	S21123001	2	コネクタブロックS	CONNECT BLOCK (S)	
11	S24887001	1	コネクタブロックSLクミ	CONNECT BLOCK (SL) ASSEMBLY	
11-1	S24454001	1	コネクタブロックSL-1	CONNECT BLOCK (SL-1)	
11-2	S24455001	1	コネクタブロックSL-2	CONNECT BLOCK (SL-2)	
11-3	018502022	2	アナボルト5X20	BOLT 5X20	
11-4	028050242	2	ハネサカネ2-5	SPRING WASHER 2-5	
12	S24886001	1	コネクタブロックSRクミ	CONNECT BLOCK (SR) ASSEMBLY	
12-1	S24456001	1	コネクタブロックSR-1	CONNECT BLOCK (SR-1)	
12-2	S24457001	1	コネクタブロックSR-2	CONNECT BLOCK (SR-2)	
12-3	018502022	2	アナボルト5X20	BOLT 5X20	
12-4	028050242	2	ハネサカネ2-5	SPRING WASHER 2-5	
13	S24828000	1	クランプリンク12	CLAMRING 12	
14	S24891000	1	オリイタウEL	FOLDING PLATE UPPER (L)	
15	S24892000	1	オリイタUIS	FOLDING PLATE UPPER (S)	

J3. 折曲ゲ関係 (特別注文部品) / Folding margin mechanism (Option parts) / Faltungsvorrichtung (Sonderzubehör) / Mécanisme de marge d'ourlet (Pièces en option) / Mecanismo de margen de plegado (Piezas a opción)

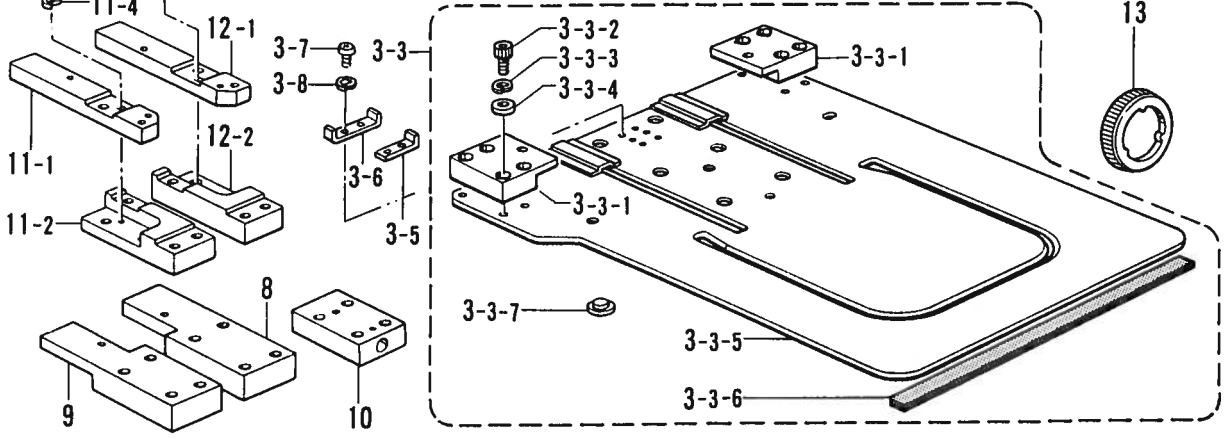
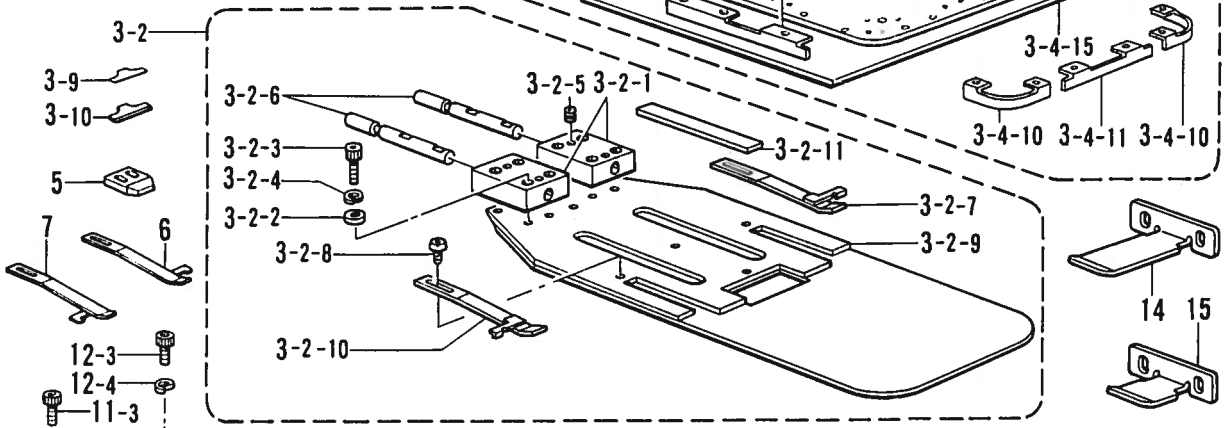
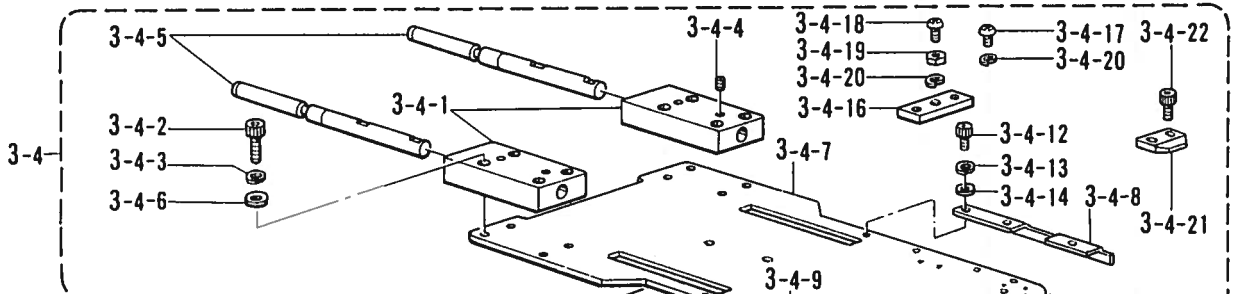
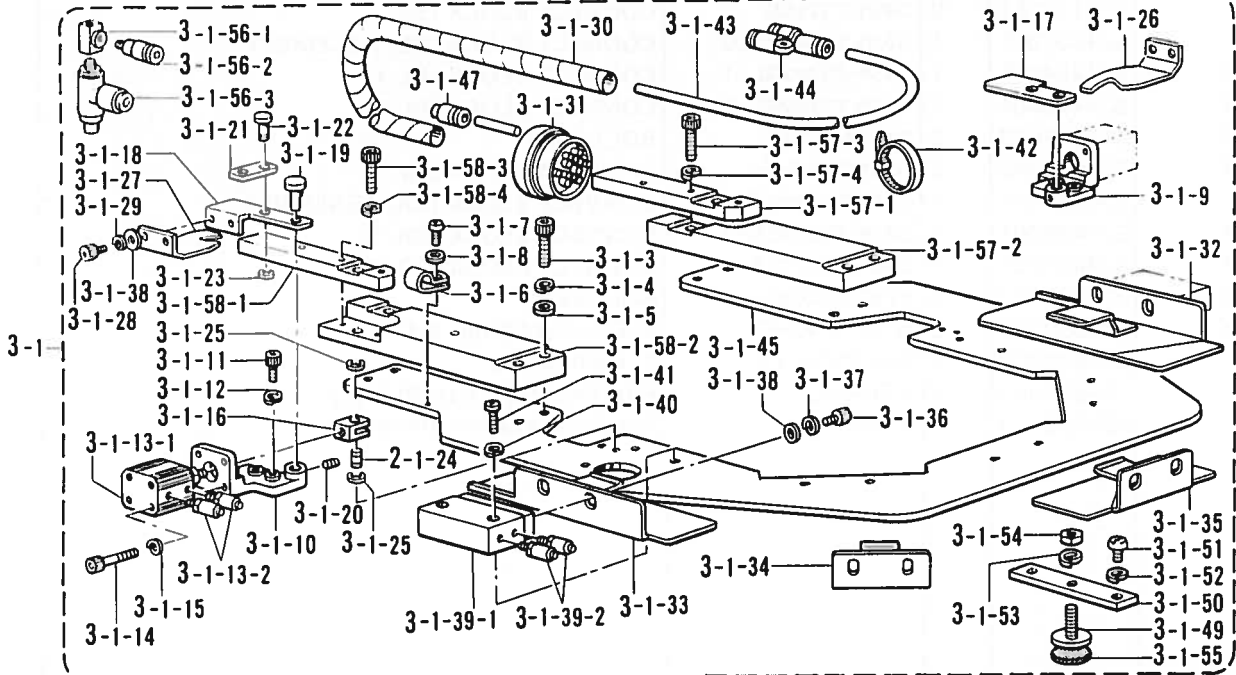

J3. 折曲ゲ関係 (特別注文部品)/Folding margin mechanism (Option parts)/Faltungsvorrichtung (Sonderzubehör)/
 Mécanisme de marge d'ourlet (Pièces en option)/Mecanismo de margen de plegado (Piezas a opción)

REF NO.	CODE	Q'TY	ヒンメイ	NAME OF PARTS	RMKS
3	S12323---	1	オリキクミ-マル	FOLDING GROUP ASSEMBLY (ROUND)	
3-1	S12324---	1	オリササエクミ-マル	FOLDING CLAMP ASSEMBLY (ROUND)	
3-1-3	018502522	8	アナホ"ルト5X25	BOLT 5X25	
3-1-4	028050242	8	ハ"ネサ"カ"ネ2-5	SPRING WASHER 2-5	
3-1-5	S20246001	8	ヒラサ"カ"ネタ"イ5	PLAIN WASHER 5	
3-1-6	552907000	1	コート"ホルタ"#10	CORD HOLDER (10N)	
3-1-7	062401006	1	ナヘ"コ4X10	SCREW 4X10	
3-1-8	025040233	1	ヒラサ"カ"ネチユウ4	PLAIN WASHER 4	
3-1-9	S12088009	1	レハ"-ヘ"-スR	LEVER BASE (R)	
3-1-10	S12089009	1	レハ"-ヘ"-スL	LEVER BASE (L)	
3-1-11	018401222	4	アナホ"ルト4X12	BOLT 4X12	
3-1-12	028040242	4	ハ"ネサ"カ"ネ2-4	SPRING WASHER 2-4	
3-1-13	S12090000	2	シリンタ"-12X10クミ	CYLINDER 12X10 ASSEMBLY	
3-1-13-1	S12091000	2	シリンタ"-12X10	CYLINDER 12X10	
3-1-13-2	S11433000	4	ホ-スニツフ"ル4M5	HOSE NIPPLE 4M5	
3-1-14	S12092000	8	CQ2ホ"ルトM3X30	CQ2 BOLT M3X30	
3-1-15	028030243	8	ハ"ネサ"カ"ネ2-3	SPRING WASHER 2-3	
3-1-16	S12093001	2	ナツクル	KNUCKLE	
3-1-17	S12094001	1	ヒンシ"R	HINGE (R)	
3-1-18	S12095001	1	ヒンシ"L	HINGE (L)	
3-1-19	S12096001	2	ヒンシ"ピン	PIN	
3-1-20	014400522	2	アナクホ"ミ4X5	SET SCREW 4X5	
3-1-21	S12097001	2	タイフ"レート	TIE PLATE	
3-1-22	S12098001	2	ピン	PIN	
3-1-23	048050342	2	トメフE5	STOP RING E5	
3-1-24	S12099001	2	ナツクルピン	KNUCKLE PIN	
3-1-25	048050342	4	トメフE5	STOP RING E5	
3-1-26	S12475100	1	メントリイタR"タイ	TUCKING BLADE (R) LARGE	
3-1-27	S12476100	1	メントリイタL"タイ	TUCKING BLADE (L) LARGE	
3-1-28	018400632	4	アナホ"ルト4X6	BOLT 4X6	
3-1-29	028040242	4	ハ"ネサ"カ"ネ2-4	SPRING WASHER 2-4	
3-1-30	S12214000	1	スパイラル640L	SPIRAL 640L	
3-1-31	S12106000	1	マルチコネクタP	MULTI CONNECTOR (P)	
3-1-32	S12325---	1	オリイタR-マル	TUCKING BLADE (R)(ROUND)	
3-1-33	S12326---	1	オリイタL-マル	TUCKING BLADE (L)(ROUND)	
3-1-34	S12327---	2	オリイタS-マル	TUCKING BLADE (S)(ROUND)	
3-1-35	S12328---	1	オリイタM-マル	TUCKING BLADE (M)(ROUND)	
3-1-36	018400632	10	アナホ"ルト4X6	BOLT 4X6	
3-1-37	028040242	10	ハ"ネサ"カ"ネ2-4	SPRING WASHER 2-4	
3-1-38	158722002	14	サ"カ"ネ4.2	WASHER 4.2	
3-1-39	S12102000	5	ツインロッド"シリンタ"-クミ	TWIN ROD CYLINDER ASSEMBLY	
3-1-39-1	S12103000	5	ツインロッド"シリンタ"-	TWIN ROD CYLINDER	
3-1-39-2	S11433000	10	ホ-スニツフ"ル4M5	HOSE NIPPLE 4M5	
3-1-40	028040243	10	ハ"ネサ"カ"ネ2-4	SPRING WASHER 2-4	
3-1-41	062402016	10	ナヘ"コM4X20	SCREW M4X20	
3-1-42	S04159000	4	バンド"1M	BAND 1M	
3-1-43	S12205000	1	エアホ-ス4X2.5-29	AIR TUBE 4X2.5-29	
3-1-44	S12104000	8	ユニオンワイ4	UNION-Y 4	
3-1-45	S12329---	1	オリササエ-マル	FOLDING CLAMP (ROUND)	
3-1-47	S19555000	2	キャツフ"4	CAP 4	
3-1-49	S12291001	2	アジ"ヤストネジ"	ADJUST SCREW	
3-1-50	S12294001	2	トリツケイタ(オリササエ)	FITTING PLATE (FOLDING CLAMP)	
3-1-51	062401006	4	ナヘ"コ4X10	SCREW 4X10	
3-1-52	028040243	4	ハ"ネサ"カ"ネ2-4	SPRING WASHER 2-4	
3-1-53	028060243	2	ハ"ネサ"カ"ネ2-6	SPRING WASHER 2-6	
3-1-54	021060206	2	2シユナツト6	NUT 6	
3-1-55	S12297000	2	スポンジ"2-30	SPONGE 2X15X1200	
3-1-56	S15564000	1	チ-M5クミ	T-M5 ASSEMBLY	
3-1-56-1	S15563000	1	チ-M5	T-M5	
3-1-56-2	S04905000	1	ハーフユニオン	HALF UNION	
3-1-56-3	S14328000	2	シホ"リハ"ン	THROTTLE VALVE	
3-1-57	S24888001	1	コネクタフ"ロツクRクミ	CONNECT BLOCK (R) ASSEMBLY	

J3. 折曲ゲ関係 (特別注文部品)/Folding margin mechanism (Option parts)/Faltungsvorrichtung (Sonderzubehör)/
 Mécanisme de marge d'ourlet (Pièces en option)/Mecanismo de margen de plegado (Piezas a opción)

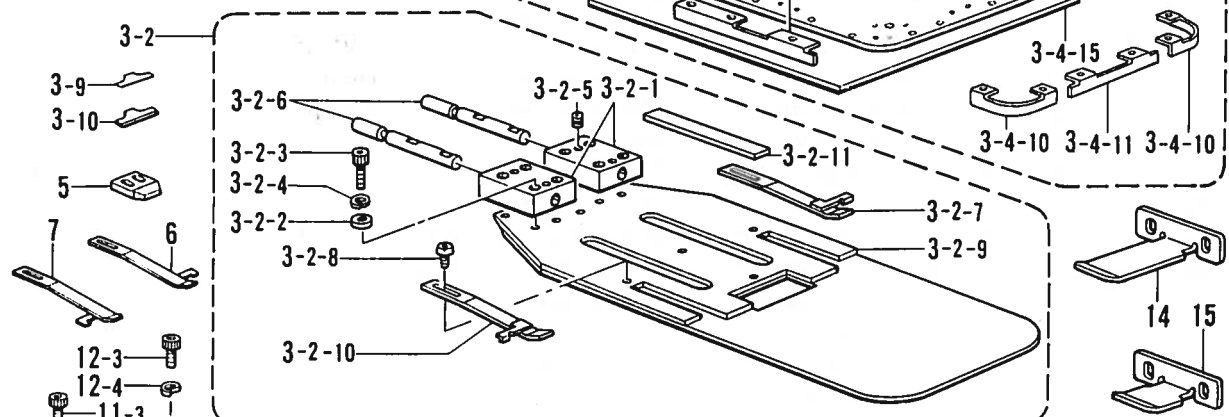
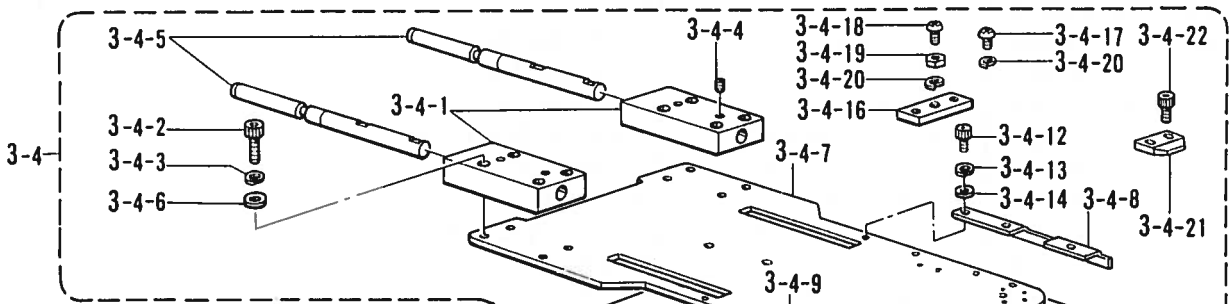
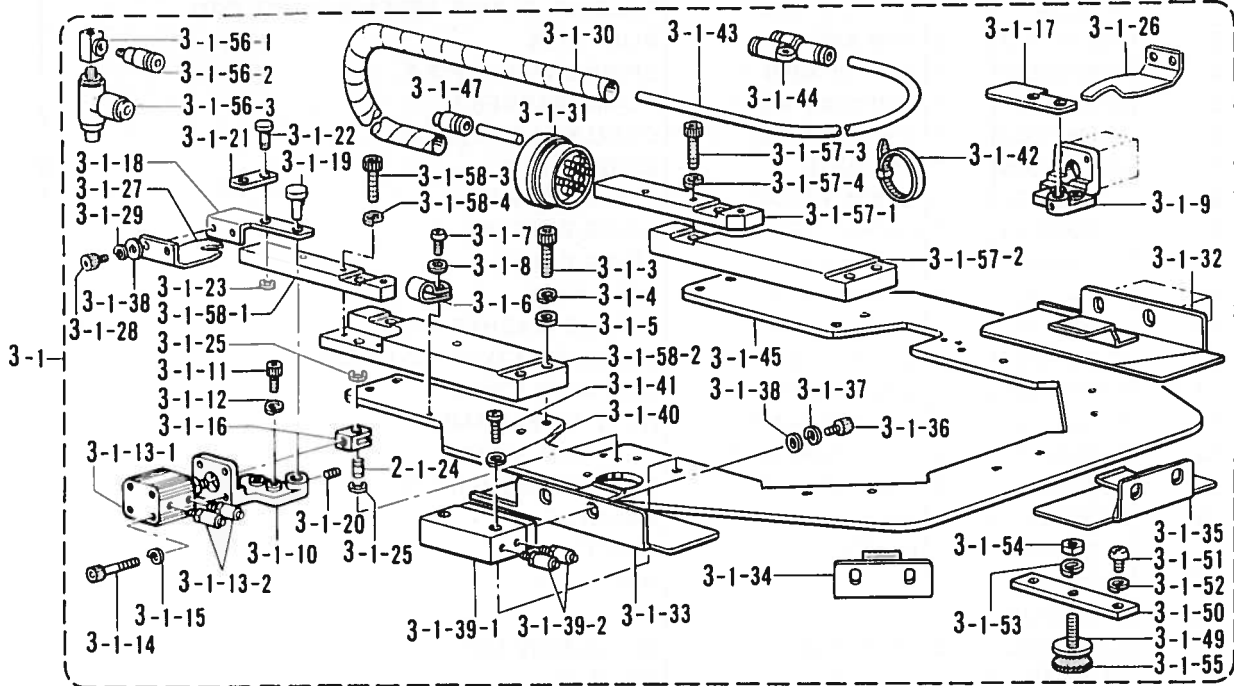

J3. 折曲ゲ関係 (特別注文部品)/Folding margin mechanism (Option parts)/Faltungsvorrichtung (Sonderzubehör)/
 Mécanisme de marge d'ourlet (Pièces en option)/Mecanismo de margen de plegado (Piezas a opción)

REF.NO.	CODE	Q'TY	ヒンメイ	NAME OF PARTS	RMKS
3-1-57-1	S24460001	1	コネクタブ"ロックR-1	CONNECT BLOCK (R-1)	
3-1-57-2	S24461001	1	コネクタブ"ロックR-2	CONNECT BLOCK (R-2)	
3-1-57-3	018502022	2	アナホ"ルト5X20	BOLT 5X20	
3-1-57-4	028050242	2	ハ"ネサ"カ"ネ2-5	SPRING WASHER 2-5	
3-1-58	S24889001	1	コネクタブ"ロックLクミ	CONNECT BLOCK (L) ASSEMBLY	
3-1-58-1	S24458001	1	コネクタブ"ロックL-1	CONNECT BLOCK (L-1)	
3-1-58-2	S24459001	1	コネクタブ"ロックL-2	CONNECT BLOCK (L-2)	
3-1-58-3	018502022	2	アナホ"ルト5X20	BOLT 5X20	
3-1-58-4	028050242	2	ハ"ネサ"カ"ネ2-5	SPRING WASHER 2-5	
3-2	S12330---	1	ケ"ー"ジ"クミ"マル	CENTER BLADE ASSEMBLY (ROUND)	
3-2-1	S12107001	2	コネクタブ"ロック(GAGE)	CONNECT BLOCK (CENTER BLADE)(GAGE)	
3-2-2	158722002	8	サ"カ"ネ4.2	WASHER 4.2	
3-2-3	018402032	8	アナホ"ルト4X20	BOLT 4X20	
3-2-4	028040242	8	ハ"ネサ"カ"ネ2-4	SPRING WASHER 2-4	
3-2-5	014500522	4	ア"ナ"ト"メ"ネ"シ"5"ク"ホ"ミ	SET SCREW 5	
3-2-6	S12108001	2	コネクタブ"ピン(ケ"ー"ジ")	PIN (CENTER BLADE)(GAGE)	
3-2-7	S12109100	1	イ"タ"ハ"ネ"R	PLATE SPRING (R)	
3-2-8	060300414	4	ハ"イ"ン"ト"3X4	SCREW 3X4	
3-2-9	S12331---	1	ケ"ー"ジ"ー"マル	CENTER BLADE (ROUND)	
3-2-10	S12105100	1	イ"タ"ハ"ネ"L	PLATE SPRING (L)	
3-2-11	S12278000	2	ウ"ケ"イ"タ"(ケ"ー"ジ")	SUPPORT PLATE (CENTER BLADE)	
3-3	S12332---	1	オ"サ"エ"ク"ミ"マル	SEWING CLAMP ASSEMBLY (ROUND)	
3-3-1	S12110001	2	コネクタブ"ロック(オ"サ"エ)	CONNECT BLOCK (PRESSER)	
3-3-2	018401022	8	アナホ"ルト4X10	BOLT 4X10	
3-3-3	028040242	8	ハ"ネサ"カ"ネ2-4	SPRING WASHER 2-4	
3-3-4	158722002	8	サ"カ"ネ4.2	WASHER 4.2	
3-3-5	S12333---	1	オ"サ"エ"ー"マル	SEWING CLAMP (ROUND)	
3-3-6	S12298000	2	フ"ォ"ー"ム"3X15X1000	FORM 3X15X1000	
3-3-7	S12279000	6	ウ"ケ"イ"タ"(オ"サ"エ)	SUPPORT PLATE (PRESSER)	
3-4	S12334---	1	ナ"カ"オ"サ"エ"ク"ミ"マル	INNER CLAMP ASSEMBLY (ROUND)	
3-4-1	S12113001	2	コネクタブ"ロック(ナ"カ)	CONNECT BLOCK (INNER)	
3-4-2	018502522	8	アナホ"ルト5X25	BOLT 5X25	
3-4-3	028050242	8	ハ"ネサ"カ"ネ2-5	SPRING WASHER 2-5	
3-4-4	014500522	4	ア"ナ"ト"メ"ネ"シ"5"ク"ホ"ミ	SET SCREW 5	
3-4-5	S12114001	2	コネクタブ"ピン(ナ"カ)	PIN (INNER)	
3-4-6	S20246001	8	ヒ"ラ"サ"カ"ネ"タ"イ"5	PLAIN WASHER 5	
3-4-7	S12335---	1	ナ"カ"オ"サ"エ"ー"マル	INNER CLAMP (ROUND)	
3-4-8	S12336---	1	ナ"カ"オ"サ"エ"ウ"1"ー"マル	INNER CLAMP UPPER 1 (ROUND)	
3-4-9	S12337---	1	ナ"カ"オ"サ"エ"ウ"2"ー"マル	INNER CLAMP UPPER 2 (ROUND)	
3-4-10	S12338---	2	ナ"カ"オ"サ"エ"ウ"3"ー"マル	INNER CLAMP UPPER 3 (ROUND)	
3-4-11	S12339---	1	ナ"カ"オ"サ"エ"ウ"4"ー"マル	INNER CLAMP UPPER 4 (ROUND)	
3-4-12	018300532	12	アナホ"ルト3X5	BOLT 3X5	
3-4-13	028030242	12	ハ"ネサ"カ"ネ2-3	SPRING WASHER 2-3	
3-4-14	025030232	12	ヒ"ラ"サ"カ"ネ"チ"ユ"3	PLAIN WASHER 3	
3-4-15	S12117000	1	フ"ォ"ー"ム"2X200X200	FORM 2X200X200	
3-4-16	S12485001	2	ト"リ"ツ"ケ"イ"タ"(ナ"カ"オ"サ"エ)	FITTING PLATE (INNER CLAMP)	
3-4-17	062400806	4	ナ"ハ"コ"4X8	SCREW M4X8	
3-4-18	062401416	2	ナ"ハ"コ"4X14	SCREW 4X14	
3-4-19	021400103	2	ナ"ツ"1"シ"ユ"4	NUT 4	
3-4-20	028040243	6	ハ"ネサ"カ"ネ2-4	SPRING WASHER 2-4	
3-4-21	S12487000	5	オ"リ"イ"タ"ウ"ケ"(ナ"カ"オ"サ"エ)	FOLDING PLATE SUPPORT (INNER CLAMP)	
3-4-22	018300532	10	アナホ"ルト3X5	BOLT 3X5	
3-5	S12111001	3	ス"リ"ツ"ト"C	SLIT (C)	
3-6	S12112001	3	ス"リ"ツ"ト"D	SLIT (D)	
3-7	062300502	6	ナ"ハ"コ"3X5	SCREW 3X5	
3-8	028030242	6	ハ"ネサ"カ"ネ2-3	SPRING WASHER 2-3	
3-9	S16514000	2	ス"パ"ー"サ"0.05	SPACER 0.05	
3-10	S16513000	2	ス"パ"ー"サ"0.1	SPACER 0.1	
5	S12494000	1	オ"リ"イ"タ"ウ"ケ"シ"ョ"ウ	FOLDING PLATE SUPPORT (SMALL)	
6	S15565100	1	イ"タ"ハ"ネ"R"0.8	PLATE SPRING (R) 0.8	
7	S15566100	1	イ"タ"ハ"ネ"L"0.8	PLATE SPRING (L) 0.8	
8	S21121001	1	コネクタブ"ロックSSR	CONNECT BLOCK (SSR)	

J3. 折曲ゲ関係 (特別注文部品)/Folding margin mechanism (Option parts)/Faltungsvorrichtung (Sonderzubehör)/
 Mécanisme de marge d'ourlet (Pièces en option)/Mecanismo de margen de plegado (Piezas a opción)

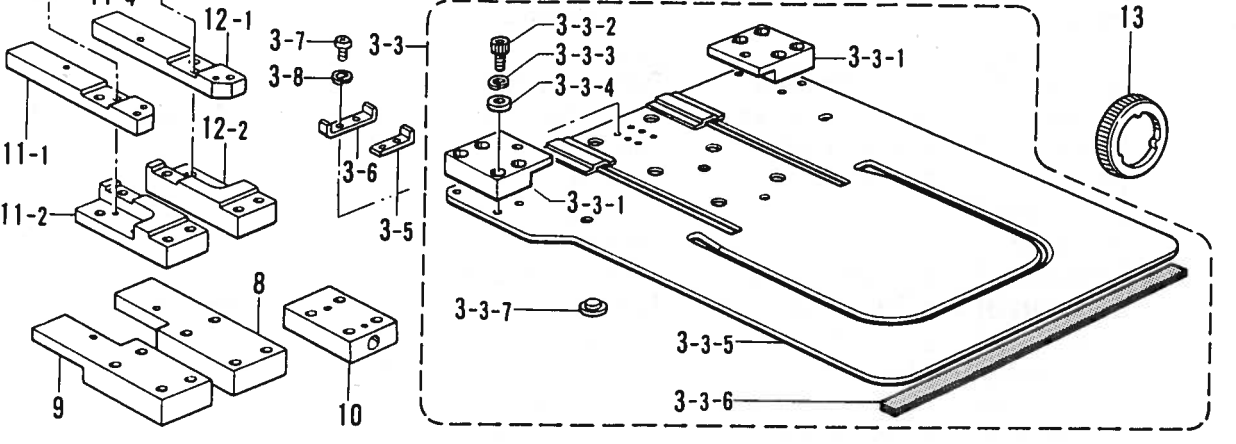
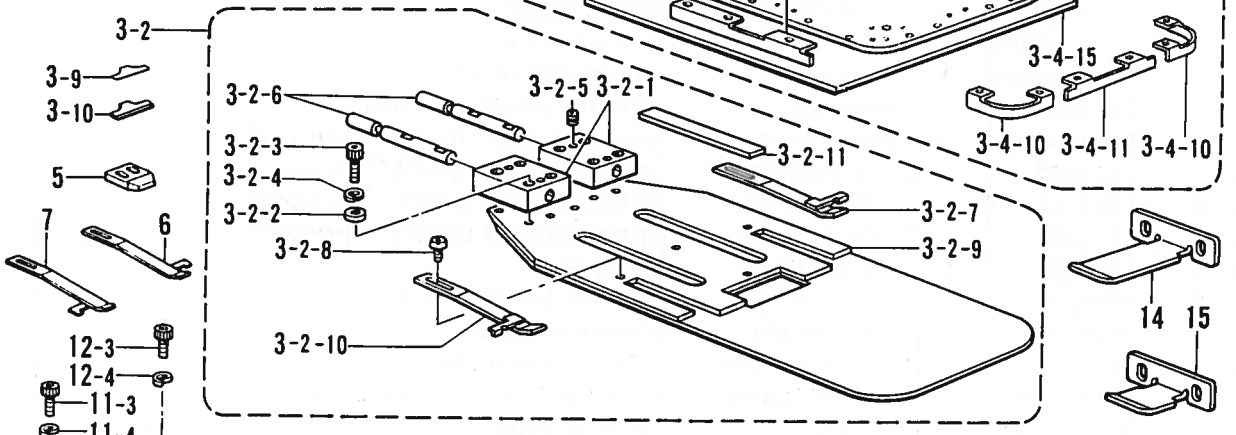
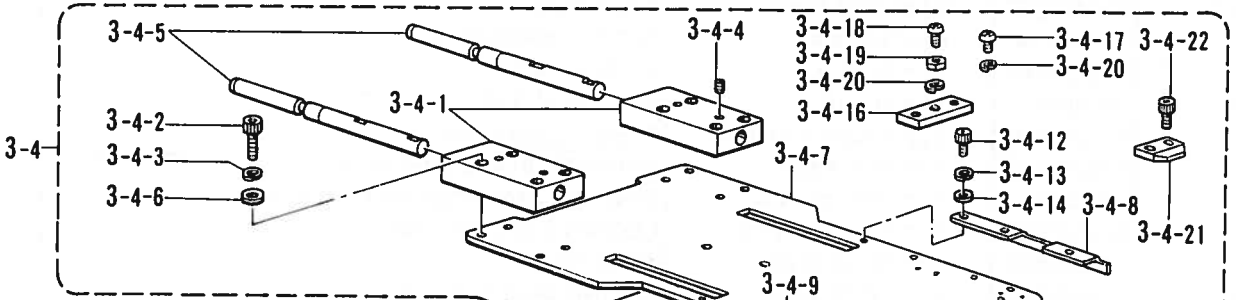
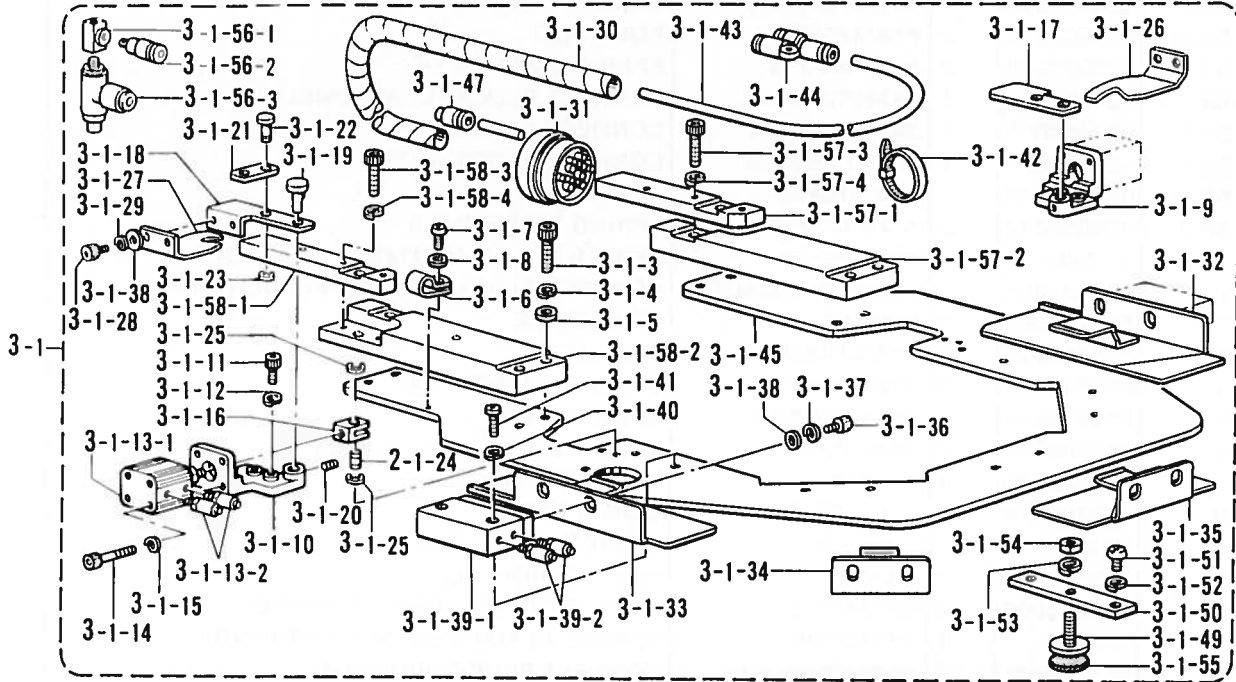

J3. 折曲ゲ関係 (特別注文部品)/Folding margin mechanism (Option parts)/Faltungsvorrichtung (Sonderzubehör)/
 Mécanisme de marge d'ourlet (Pièces en option)/Mecanismo de margen de plegado (Piezas a opción)

REF.NO.	CODE	Q'TY	品名	NAME OF PARTS	RMKS
9	S21122001	1	コネクタブロックSSL	CONNECT BLOCK (SSL)	
10	S21123001	2	コネクタブロックS	CONNECT BLOCK (S)	
11	S24887001	1	コネクタブロックSLクミ	CONNECT BLOCK (SL) ASSEMBLY	
11-1	S24454001	1	コネクタブロックSL-1	CONNECT BLOCK (SL-1)	
11-2	S24455001	1	コネクタブロックSL-2	CONNECT BLOCK (SL-2)	
11-3	018502022	2	アナボルト5X20	BOLT 5X20	
11-4	028050242	2	ハネサカネ2-5	SPRING WASHER 2-5	
12	S24886001	1	コネクタブロックSRクミ	CONNECT BLOCK (SR) ASSEMBLY	
12-1	S24456001	1	コネクタブロックSR-1	CONNECT BLOCK (SR-1)	
12-2	S24457001	1	コネクタブロックSR-2	CONNECT BLOCK (SR-2)	
12-3	018502022	2	アナボルト5X20	BOLT 5X20	
12-4	028050242	2	ハネサカネ2-5	SPRING WASHER 2-5	
13	S24828000	1	クランプリンク12	CLAMRING 12	
14	S24891000	1	オリイタウEL	FOLDING PLATE UPPER (L)	
15	S24892000	1	オリイタウES	FOLDING PLATE UPPER (S)	

J4. 折曲ゲ関係 (特別注文部品) / Folding margin mechanism (Option parts) / Faltungsvorrichtung (Sonderzubehör) / Mécanisme de marge d'ourlet (Pièces en option) / Mecanismo de margen de plegado (Piezas a opción)

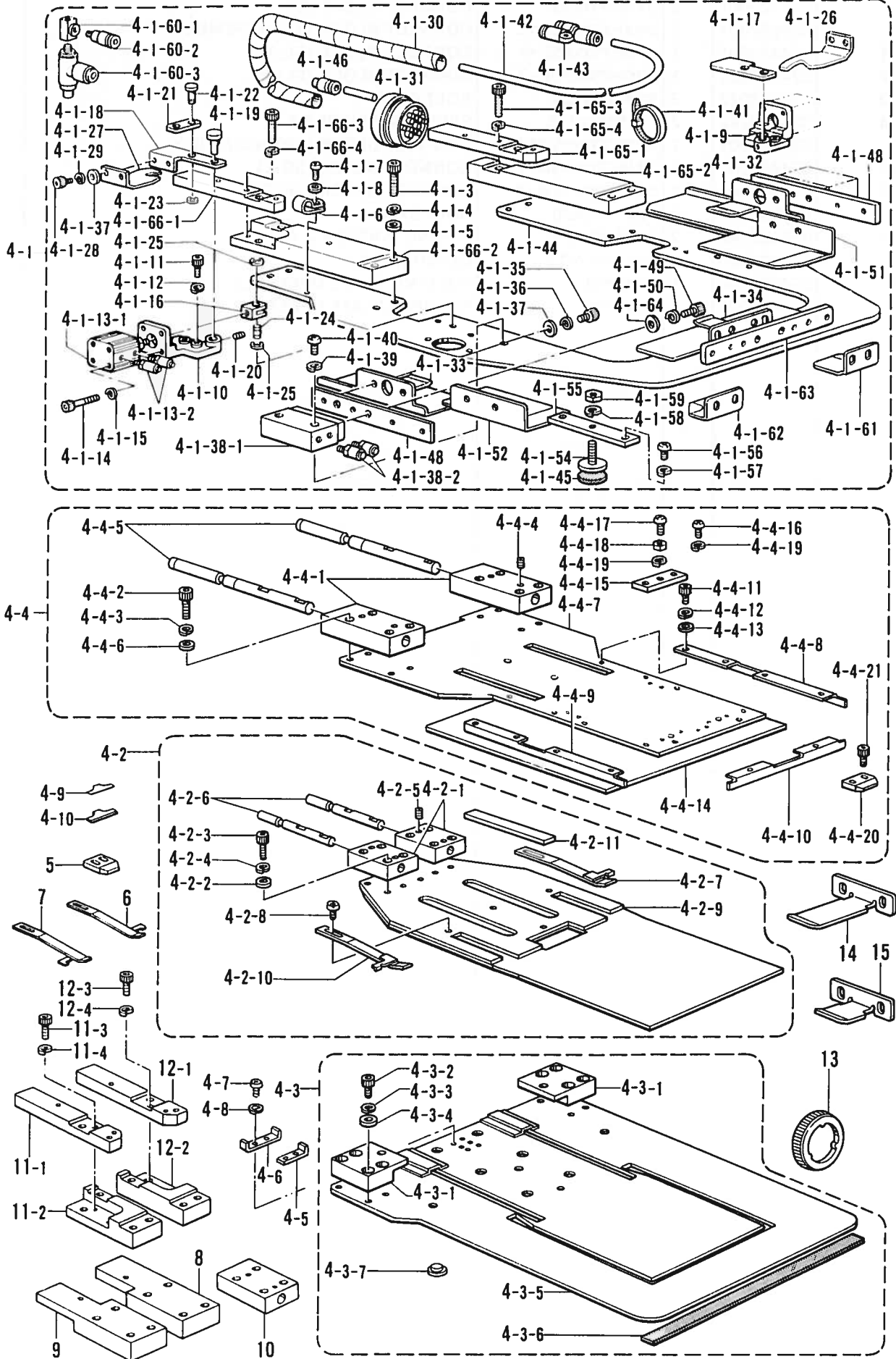

J4. 折曲ケ関係 (特別注文部品) / Folding margin mechanism (Option parts) / Faltungsvorrichtung (Sonderzubehör) / Mécanisme de marge d'ourlet (Pièces en option) / Mecanismo de margen de plegado (Piezas a opción)

REF NO.	CODE	Q'TY	ヒンメイ	NAME OF PARTS	RMKS
4	S12341---	1	オリキクミ-4カク	FOLDING GROUP ASSEMBLY (SQUARE)	
4-1	S12342---	1	オリササエクミ-4カク	FOLDING CLAMP ASSEMBLY (SQUARE)	
4-1-3	018502522	8	アナホ"ルト5X25	BOLT 5X25	
4-1-4	028050242	8	ハ"ネサ"カ"ネ2-5	SPRING WASHER 2-5	
4-1-5	S20246001	8	ヒラサ"カ"ネタ"イ5	PLAIN WASHER 5	
4-1-6	552907000	1	コート"ホルタ"#10	CORD HOLDER (10N)	
4-1-7	062401006	1	ナヘ"コ4X10	SCREW 4X10	
4-1-8	025040233	1	ヒラサ"カ"ネチユウ4	PLAIN WASHER 4	
4-1-9	S12088009	1	レハ"ー"へ"ースR	LEVER BASE (R)	
4-1-10	S12089009	1	レハ"ー"へ"ースL	LEVER BASE (L)	
4-1-11	018401222	4	アナホ"ルト4X12	BOLT 4X12	
4-1-12	028040242	4	ハ"ネサ"カ"ネ2-4	SPRING WASHER 2-4	
4-1-13	S12090000	2	シリンタ"-12X10クミ	CYLINDER 12X10 ASSEMBLY	
4-1-13-1	S12091000	2	シリンタ"-12X10	CYLINDER 12X10	
4-1-13-2	S11433000	4	ホ-スニツプル4M5	HOSE NIPPLE 4M5	
4-1-14	S12092000	8	CQ2ホ"ルトM3X30	CQ2 BOLT M3X30	
4-1-15	028030243	8	ハ"ネサ"カ"ネ2-3	SPRING WASHER 2-3	
4-1-16	S12093001	2	ナツクル	KNUCKLE	
4-1-17	S12094001	1	ヒンシ"R	HINGE (R)	
4-1-18	S12095001	1	ヒンシ"L	HINGE (L)	
4-1-19	S12096001	2	ヒンシ"ピン	PIN	
4-1-20	014400522	2	アナクホ"ミ34X5	SET SCREW 4X5	
4-1-21	S12097001	2	タイフ"レート	TIE PLATE	
4-1-22	S12098001	2	ピン	PIN	
4-1-23	048050342	2	トメフE5	STOP RING E5	
4-1-24	S12099001	2	ナツクルピン	KNUCKLE PIN	
4-1-25	048050342	4	トメフE5	STOP RING E5	
4-1-26	S12475100	1	メントリイタRタイ	TUCKING BLADE (R) LARGE	
4-1-27	S12476100	1	メントリイタLタイ	TUCKING BLADE (L) LARGE	
4-1-28	018400632	4	アナホ"ルト4X6	BOLT 4X6	
4-1-29	028040242	4	ハ"ネサ"カ"ネ2-4	SPRING WASHER 2-4	
4-1-30	S12214000	1	スパイラル640L	SPIRAL 640L	
4-1-31	S12106000	1	マルチコネクタP	MULTI CONNECTOR (P)	
4-1-32	S12343---	1	オリイタR-4カク	TUCKING BLADE (R) (SQUARE)	
4-1-33	S12344---	1	オリイタL-4カク	TUCKING BLADE (L) (SQUARE)	
4-1-34	S12345---	1	オリイタD-4カク	TUCKING BLADE (D) (SQUARE)	
4-1-35	018400632	14	アナホ"ルト4X6	BOLT 4X6	
4-1-36	028040242	14	ハ"ネサ"カ"ネ2-4	SPRING WASHER 2-4	
4-1-37	158722002	18	サ"カ"ネ4.2	WASHER 4.2	
4-1-38	S12102000	3	ツインロッド"シリンタ"ークミ	TWIN ROD CYLINDER ASSEMBLY	
4-1-38-1	S12103000	3	ツインロッド"シリンタ"ー	TWIN ROD CYLINDER	
4-1-38-2	S11433000	6	ホ-スニツプル4M5	HOSE NIPPLE 4M5	
4-1-39	028040243	6	ハ"ネサ"カ"ネ2-4	SPRING WASHER 2-4	
4-1-40	062402016	6	ナヘ"コM4X20	SCREW M4X20	
4-1-41	S04159000	4	バンド"1M	BAND 1M	
4-1-42	S12205000	1	エアホ-ス4X2.5-29	AIR TUBE 4X2.5-29	
4-1-43	S12104000	4	ユニオンワイ4	UNION-Y 4	
4-1-44	S12346---	1	オリササエ-4カク	FOLDING CLAMP (SQUARE)	
4-1-45	S12297000	2	スポンジ"2-30	SPONGE 2X15X1200	
4-1-46	S19555000	2	キャップ4	CAP 4	
4-1-48	S12469000	2	オリイタササエ-4カク	FOLDING PLATE SUPPORT	
4-1-49	018400832	6	アナホ"ルト4X8	BOLT 4X8	
4-1-50	028040242	6	ハ"ネサ"カ"ネ2-4	SPRING WASHER 2-4	
4-1-51	S12470000	1	オリイタRD-4カク	TUCKING BLADE (RD) (SQUARE)	
4-1-52	S12471000	1	オリイタLD-4カク	TUCKING BLADE (LD) (SQUARE)	
4-1-54	S12291001	2	アジ"ヤストネシ"	ADJUST SCREW	
4-1-55	S12294001	2	トリツケイタ(オリササエ)	FITTING PLATE (FOLDING CLAMP)	
4-1-56	062401006	4	ナヘ"コ4X10	SCREW 4X10	
4-1-57	028040243	4	ハ"ネサ"カ"ネ2-4	SPRING WASHER 2-4	
4-1-58	028060243	2	ハ"ネサ"カ"ネ2-6	SPRING WASHER 2-6	
4-1-59	021060206	2	2シユナツト6	NUT 6	
4-1-60	S15564000	1	チ- M5クミ	T-M5 ASSEMBLY	

J4. 折曲ヶ関係 (特別注文部品)/Folding margin mechanism (Option parts)/Faltungsvorrichtung (Sonderzubehör)/
 Mécanisme de marge d'ourlet (Pièces en option)/Mecanismo de margen de plegado (Piezas a opción)

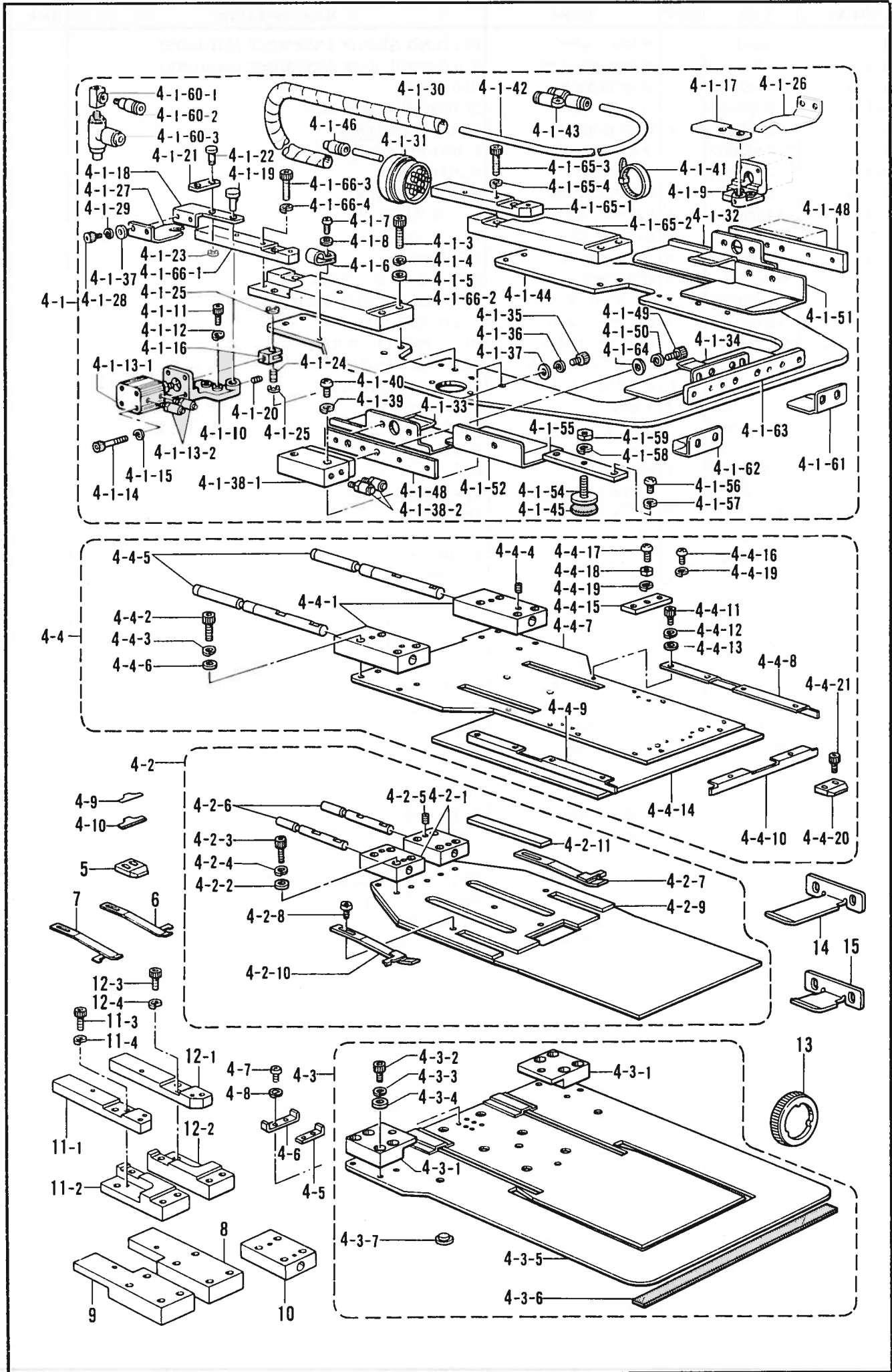

J4. 折曲ゲ関係 (特別注文部品) / Folding margin mechanism (Option parts) / Faltungsvorrichtung (Sonderzubehör) / Mécanisme de marge d'ourlet (Pièces en option) / Mecanismo de margen de plegado (Piezas a opción)

REF.NO.	CODE	Q'TY	ヒンメイ	NAME OF PARTS	RMKS
4-1-60-1	S15563000	1	チ-M5	T-M5	
4-1-60-2	S04905000	1	ハーフユニオン	HALF UNION	
4-1-60-3	S14328000	2	シボ"リハ"ン	THROTTLE VALVE	
4-1-61	S16515---	1	オリイタRDD-4カク	TUCKING BLADE (RDD)(SQUARE)	
4-1-62	S16516---	1	オリイタLDD-4カク	TUCKING BLADE (LDD)(SQUARE)	
4-1-63	S16517---	1	オリイタササID-4カク	TUCKING BLADE SUPPORT (D)(SQUARE)	
4-1-64	025040132	6	ヒラサ"カ"ネシヨウ4	PLAIN WASHER 4	
4-1-65	S24888001	1	コネクタブ"ロツクRクミ	CONNECT BLOCK (R) ASSEMBLY	
4-1-65-1	S24460001	1	コネクタブ"ロツクR-1	CONNECT BLOCK (R-1)	
4-1-65-2	S24461001	1	コネクタブ"ロツクR-2	CONNECT BLOCK (R-2)	
4-1-65-3	018502022	2	アナボ"ルト5X20	BOLT 5X20	
4-1-65-4	028050242	2	ハ"ネサ"カ"ネ2-5	SPRING WASHER 2-5	
4-1-66	S24889001	1	コネクタブ"ロツクLクミ	CONNECT BLOCK (L) ASSEMBLY	
4-1-66-1	S24458001	1	コネクタブ"ロツクL-1	CONNECT BLOCK (L-1)	
4-1-66-2	S24459001	1	コネクタブ"ロツクL-2	CONNECT BLOCK (L-2)	
4-1-66-3	018502022	2	アナボ"ルト5X20	BOLT 5X20	
4-1-66-4	028050242	2	ハ"ネサ"カ"ネ2-5	SPRING WASHER 2-5	
4-2	S12347---	1	ゲ"ー"ジ"クミ-4カク	CENTER BLADE ASSEMBLY (SQUARE)	
4-2-1	S12107001	2	コネクタブ"ロツク(GAGE)	CONNECT BLOCK (CENTER BLADE)(GAGE)	
4-2-2	158722002	8	ザ"カ"ネ4.2	WASHER 4.2	
4-2-3	018402032	8	アナボ"ルト4X20	BOLT 4X20	
4-2-4	028040242	8	ハ"ネサ"カ"ネ2-4	SPRING WASHER 2-4	
4-2-5	014500522	4	アナトメネジ"5クホ"ミ	SET SCREW 5	
4-2-6	S12108001	2	コネクタブ"ピン(ゲ"ー"ジ")	PIN (CENTER BLADE)(GAGE)	
4-2-7	S12109100	1	イタハ"ネR	PLATE SPRING (R)	
4-2-8	060300414	4	ハ"イント"3X4	SCREW 3X4	
4-2-9	S12348---	1	ゲ"ー"ジ"-4カク	CENTER BLADE (SQUARE)	
4-2-10	S12105100	1	イタハ"ネL	PLATE SPRING (L)	
4-2-11	S12278000	2	ウケイタ(ゲ"ー"ジ")	SUPPORT PLATE (CENTER BLADE)	
4-3	S12349---	1	オサエクミ-4カク	SEWING CLAMP ASSEMBLY (SQUARE)	
4-3-1	S12110001	2	コネクタブ"ロツク(オサエ)	CONNECT BLOCK (PRESSER)	
4-3-2	018401022	8	アナボ"ルト4X10	BOLT 4X10	
4-3-3	028040242	8	ハ"ネサ"カ"ネ2-4	SPRING WASHER 2-4	
4-3-4	158722002	8	ザ"カ"ネ4.2	WASHER 4.2	
4-3-5	S12350---	1	オサエ-4カク	SEWING CLAMP (SQUARE)	
4-3-6	S12298000	2	フォーム3X15X1000	FORM 3X15X1000	
4-3-7	S12279000	6	ウケイタ(オサエ)	SUPPORT PLATE (PRESSER)	
4-4	S12351---	1	ナカオサエクミ-4カク	INNER CLAMP ASSEMBLY (SQUARE)	
4-4-1	S12113001	2	コネクタブ"ロツク(ナカ)	CONNECT BLOCK (INNER)	
4-4-2	018502522	8	アナボ"ルト5X25	BOLT 5X25	
4-4-3	028050242	8	ハ"ネサ"カ"ネ2-5	SPRING WASHER 2-5	
4-4-4	014500522	4	アナトメネジ"5クホ"ミ	SET SCREW 5	
4-4-5	S12114001	2	コネクタブ"ピン(ナカ)	PIN (INNER)	
4-4-6	S20246001	8	ヒラサ"カ"ネタ"イ5	PLAIN WASHER 5	
4-4-7	S12352---	1	ナカオサエ-4カク	INNER CLAMP (SQUARE)	
4-4-8	S12353---	1	ナカオサエウエ1-4カク	INNER CLAMP UPPER 1 (SQUARE)	
4-4-9	S12354---	1	ナカオサエウエ2-4カク	INNER CLAMP UPPER 2 (SQUARE)	
4-4-10	S12355---	1	ナカオサエウエ3-4カク	INNER CLAMP UPPER 3 (SQUARE)	
4-4-11	018300532	10	アナボ"ルト3X5	BOLT 3X5	
4-4-12	028030242	10	ハ"ネサ"カ"ネ2-3	SPRING WASHER 2-3	
4-4-13	025030232	10	ヒラサ"カ"ネチウ3	PLAIN WASHER 3	
4-4-14	S12117000	1	フォーム2X200X200	FORM 2X200X200	
4-4-15	S12485001	2	トリツケイタ(ナカオサエ)	FITTING PLATE (INNER CLAMP)	
4-4-16	062400806	4	ナヘ"コ4X8	SCREW M4X8	
4-4-17	062401416	2	ナヘ"コ4X14	SCREW 4X14	
4-4-18	021400103	2	ナツト1シユ4	NUT 4	
4-4-19	028040243	6	ハ"ネサ"カ"ネ2-4	SPRING WASHER 2-4	
4-4-20	S12487000	3	オリイタウケ(ナカオサエ)	FOLDING PLATE SUPPORT (INNER CLAMP)	
4-4-21	018300532	6	アナボ"ルト3X5	BOLT 3X5	
4-5	S12111001	3	スリツトC	SLIT (C)	
4-6	S12112001	3	スリツトD	SLIT (D)	
4-7	062300502	6	ナヘ"コ3X5	SCREW 3X5	

J4. 折曲ヶ関係 (特別注文部品)/Folding margin mechanism (Option parts)/Faltungsvorrichtung (Sonderzubehör)/
Mécánisme de marge d'ourlet (Pièces en option)/Mecanismo de margen de plegado (Piezas a opción)

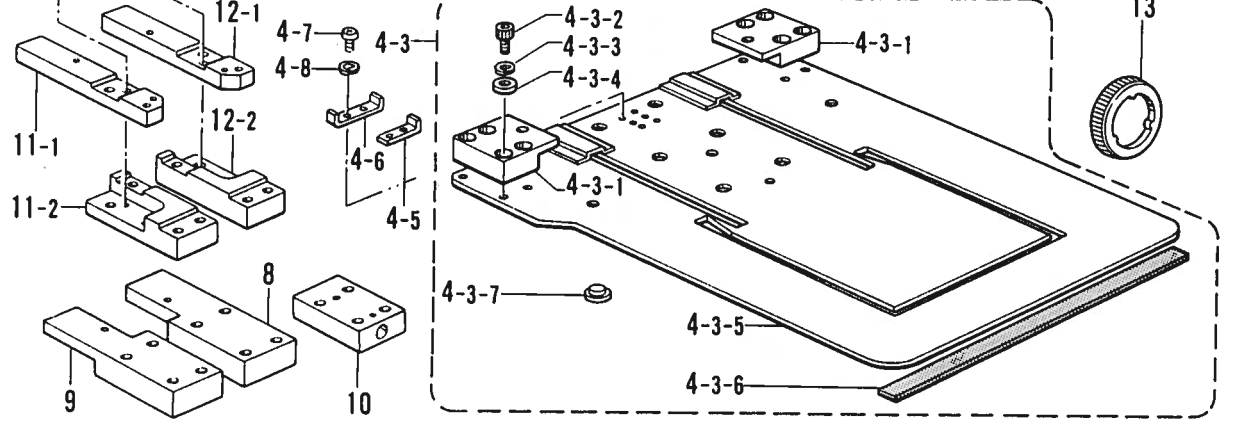
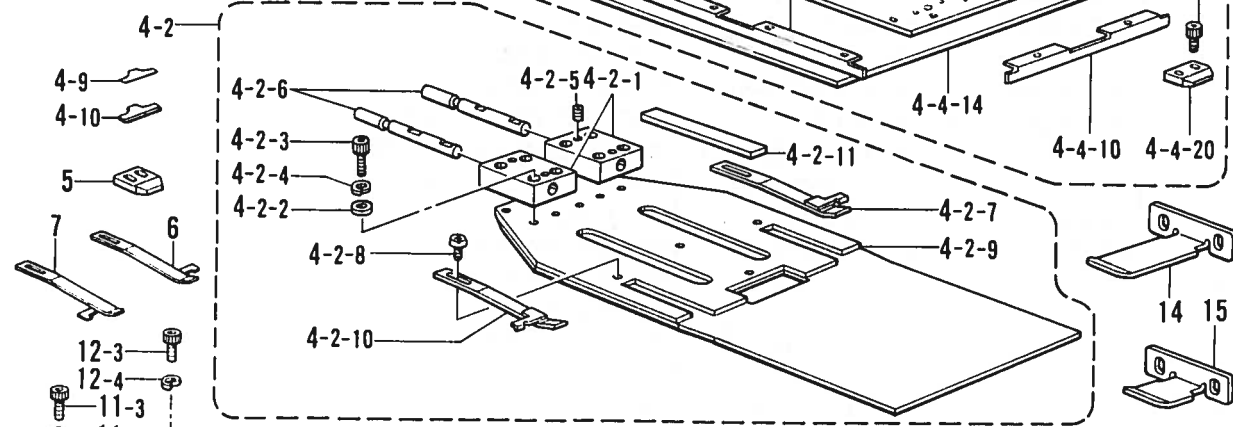
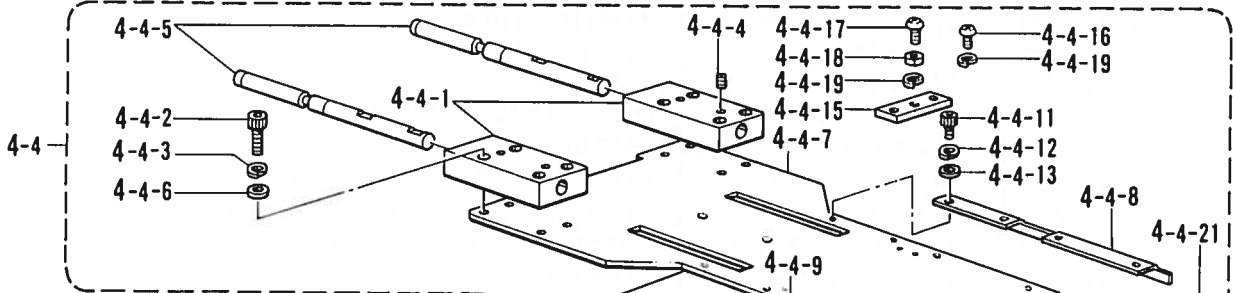
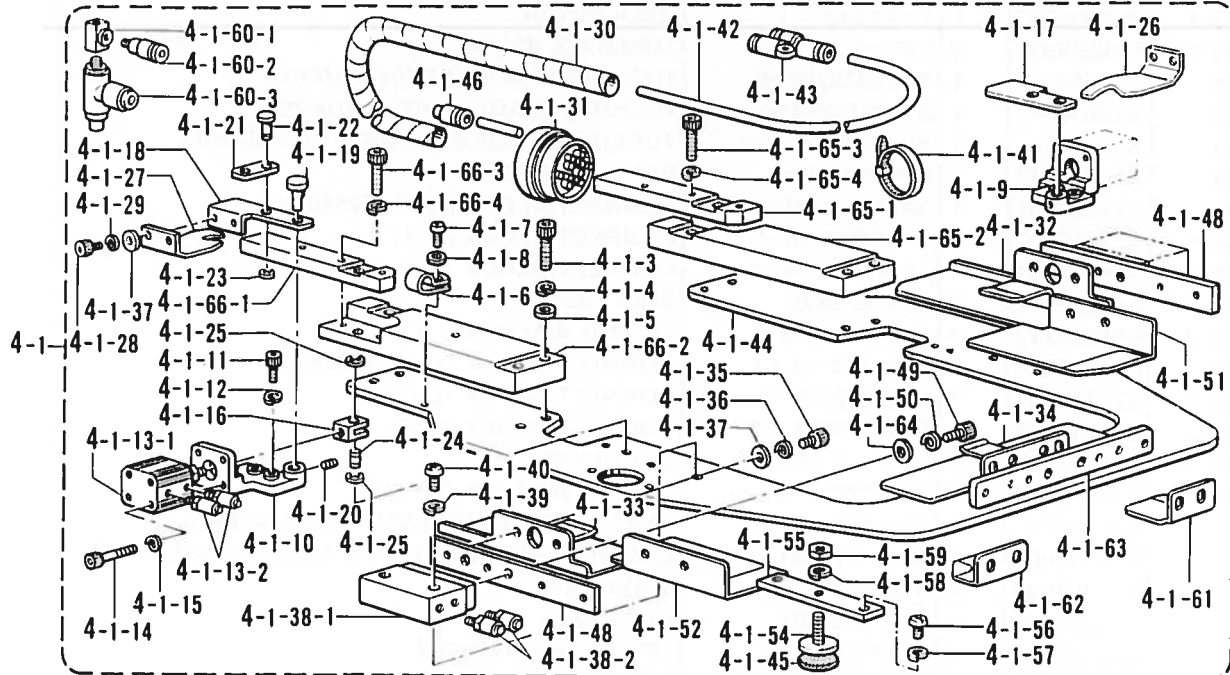

J4. 折曲ゲ関係 (特別注文部品)/Folding margin mechanism (Option parts)/Faltungsvorrichtung (Sonderzubehör)/
 Mécanisme de marge d'ourlet (Pièces en option)/Mecanismo de margen de plegado (Piezas a opción)

REF.NO.	CODE	Q'TY	ヒンメイ	NAME OF PARTS	RMKS
4-8	028030242	6	ハ"ネサ"カ"ネ2-3	SPRING WASHER 2-3	
4-9	S16514000	2	ス"ペ"ーサ0.05	SPACER 0.05	
4-10	S16513000	2	ス"ペ"ーサ0.1	SPACER 0.1	
5	S12494000	1	オリイタウケシヨウ	FOLDING PLATE SUPPORT (SMALL)	
6	S15565100	1	イタハ"ネR0.8	PLATE SPRING (R) 0.8	
7	S15566100	1	イタハ"ネL0.8	PLATE SPRING (L) 0.8	
8	S21121001	1	コネクタブ"ロックSSR	CONNECT BLOCK (SSR)	
9	S21122001	1	コネクタブ"ロックSSL	CONNECT BLOCK (SSL)	
10	S21123001	2	コネクタブ"ロックS	CONNECT BLOCK (S)	
11	S24887001	1	コネクタブ"ロックSLクミ	CONNECT BLOCK (SL) ASSEMBLY	
11-1	S24454001	1	コネクタブ"ロックSL-1	CONNECT BLOCK (SL-1)	
11-2	S24455001	1	コネクタブ"ロックSL-2	CONNECT BLOCK (SL-2)	
11-3	018502022	2	アナホ"ルト5X20	BOLT 5X20	
11-4	028050242	2	ハ"ネサ"カ"ネ2-5	SPRING WASHER 2-5	
12	S24886001	1	コネクタブ"ロックSRクミ	CONNECT BLOCK (SR) ASSEMBLY	
12-1	S24456001	1	コネクタブ"ロックSR-1	CONNECT BLOCK (SR-1)	
12-2	S24457001	1	コネクタブ"ロックSR-2	CONNECT BLOCK (SR-2)	
12-3	018502022	2	アナホ"ルト5X20	BOLT 5X20	
12-4	028050242	2	ハ"ネサ"カ"ネ2-5	SPRING WASHER 2-5	
13	S24828000	1	クランプ"リング"12	CLAMRING 12	
14	S24891000	1	オリイタウEL	FOLDING PLATE UPPER (L)	
15	S24892000	1	オリイタウES	FOLDING PLATE UPPER (S)	

K1. 折曲ゲ土台関係 / Folding margin base mechanism / Faltungsvorrichtungsgrundplatte / Mécanisme de base de marge d'ourlet / Mecanismo base de margen de plegado

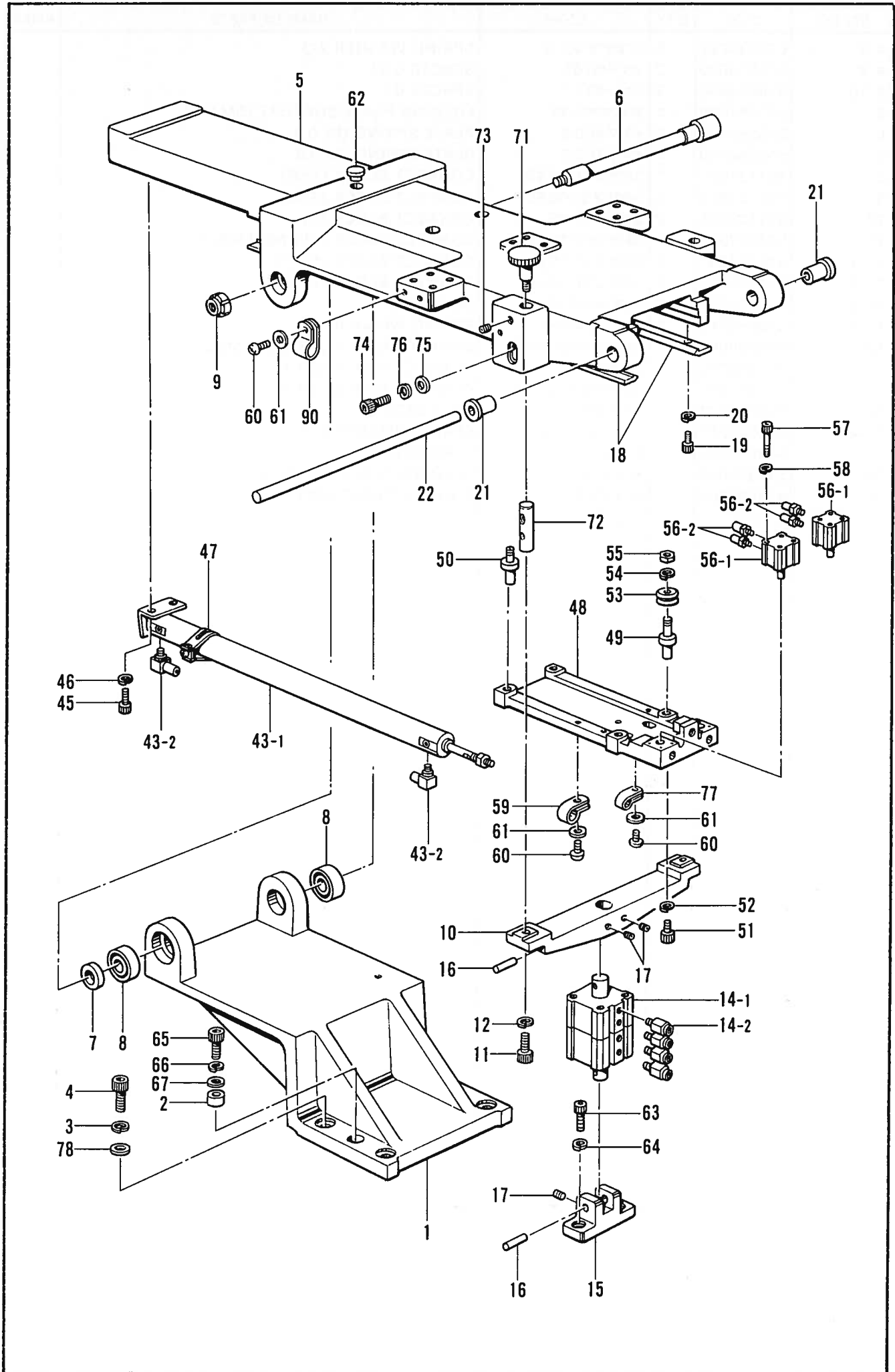

K1. 折曲ゲ土台関係 / Folding margin base mechanism / Faltungsvorrichtunggrundplatte /
 Mécanisme de base de marge d'ourlet / Mecanismo base de margen de plegado

REF NO.	CODE	Q'TY	ヒンメイ	NAME OF PARTS	RMKS
1	S15532009	1	ヒンジ"ト"タイ	HINGE BASE	
2	S12119001	2	ピン	PIN	
3	028080242	4	ハ"ネサ"カ"ネ2-8	SPRING WASHER 2-8	
4	018082522	4	アナホ"ルト8X25	BOLT 8X25	
5	S15556009	1	オリト"タ"イ	FOLDING BASE	
6	S15530001	1	オリト"タ"イシ"ク	FOLDING BASE SHAFT	
7	S15531001	1	オリト"タ"イカラー	FOLDING BASE COLLAR	
8	S12123000	2	アンキ"ユラタマシ"クウケ2	ANGULAR BALL BEARING 2	
9	S04782000	1	フラインUナツトSS-AN02	FAIN (U) NUT SS-AN02	
10	S15542109	1	オリト"タ"イヒンシ"ウエ	FOLDING BASE HINGE UPPER	
11	018081622	2	アナホ"ルト8X16	BOLT 8X16	
12	028080242	2	ハ"ネサ"カ"ネ2-8	SPRING WASHER 2-8	
14	S12125000	1	ウスカ"タシリンダ"-ABクミ	THIN TYPE CYLINDER (AB) ASSEMBLY	
14-1	S12126000	1	ウスカ"タシリンダ"-AB	THIN TYPE CYLINDER (AB)	
14-2	S04910000	4	ハーフユニオン	HALF UNION	
15	S12127109	1	オリト"タ"イヒンシ"	FOLDING BASE HINGE	
16	S12128101	2	オリト"タ"イヒンシ"シ"ク	FOLDING BASE HINGE SHAFT	
17	014500522	4	アナトメネシ"5クホ"ミ	SET SCREW 5	
18	S12129000	2	トラツクレール	TRACK RAIL	
19	018400832	20	アナホ"ルト4X8	BOLT 4X8	
20	028040242	20	ハ"ネサ"カ"ネ2-4	SPRING WASHER 2-4	
21	S12130000	2	フランジ"フ"ツシユ1520	FLANGE BUSH 1520	
22	S12131000	1	LMシャフト15	LM SHAFT 15	
43	S23396000	1	シリンダ"-20X335クミ	CYLINDER 20X335 ASSEMBLY	
43-1	S23397000	1	シリンダ"-20X335	CYLINDER 20X335	
43-2	S12150000	2	ホースエルボ"M-5HL-4	TUBE ELBOW (M-5HL-4)	
45	018501222	2	アナホ"ルト5X12	BOLT 5X12	
46	028050242	2	ハ"ネサ"カ"ネ2-5	SPRING WASHER 2-5	
47	S11880000	1	スイッチトリツケカナク"20	SWITCH SET METAL FITTING 20	
48	S12151009	1	ケー"シ"ササエ	CENTER BLADE SUPPORT	
49	S12152001	2	ケー"シ"ササエシ"クA	CENTER BLADE SUPPORT SHAFT (A)	
50	S12153001	2	ケー"シ"ササエシ"クB	CENTER BLADE SUPPORT SHAFT (B)	
51	018400822	4	アナホ"ルト4X8	BOLT 4X8	
52	028040242	4	ハ"ネサ"カ"ネ2-4	SPRING WASHER 2-4	
53	S12154000	4	ガ"イト"ホイール	GUIDE WHEEL	
54	028040242	4	ハ"ネサ"カ"ネ2-4	SPRING WASHER 2-4	
55	021400103	4	ナツト1シユ4	NUT 4	
56	S12051000	2	ロックシリンダ"-クミA	LOCK CYLINDER ASSEMBLY (A)	
56-1	S12052000	2	ロックシリンダ"-	LOCK CYLINDER	
56-2	S11433000	4	ホースニツプ"ル4M5	HOSE NIPPLE 4M5	
57	S12053000	8	CQ2ホ"ルトM3X25	CQ2 BOLT M3X25	
58	028030243	8	ハ"ネサ"カ"ネ2-3	SPRING WASHER 2-3	
59	525664000	1	コート"ホルダ"#6	CORD HOLDER (6N)	
60	062400806	7	ナヘ"コ4X8	SCREW M4X8	
61	025040233	7	ヒラサ"カ"ネチユウ4	PLAIN WASHER 4	
62	117934009	1	メクラセン	OIL CAP	
63	018062022	2	アナホ"ルト6X20	BOLT 6X20	
64	028060242	2	ハ"ネサ"カ"ネ2-6	SPRING WASHER 2-6	
65	018062522	2	アナホ"ルト6X25	BOLT 6X25	
66	028060242	2	ハ"ネサ"カ"ネ2-6	SPRING WASHER 2-6	
67	025060232	2	ヒラサ"カ"ネチユウ6	PLAIN WASHER 6	
71	S15526001	2	アジ"ヤストネジ"	ADJUST SCREW	
72	S15525001	2	チヨウセイシ"ク	ADJUST SHAFT	
73	014060632	2	アナトメ6X6クホ"ミ	SET SCREW 6X6	
74	018062022	2	アナホ"ルト6X20	BOLT 6X20	
75	025060232	2	ヒラサ"カ"ネチユウ6	PLAIN WASHER 6	
76	028060242	2	ハ"ネサ"カ"ネ2-6	SPRING WASHER 2-6	
77	S00480000	4	コート"ホルダ"#5	CORD HOLDER 5N	
78	025080232	4	ヒラサ"カ"ネチユウ8	PLAIN WASHER 8	
90	149287000	2	ナイロンクランプ"7N	NYLON CLAMP 7N	

K2. 折曲ゲ土台関係 / Folding margin base mechanism / Faltungsvorrichtungsgrundplatte / Mécanisme de base de marge d'ourlet / Mecanismo base de margen de plegado

<BAS-752, 750L>

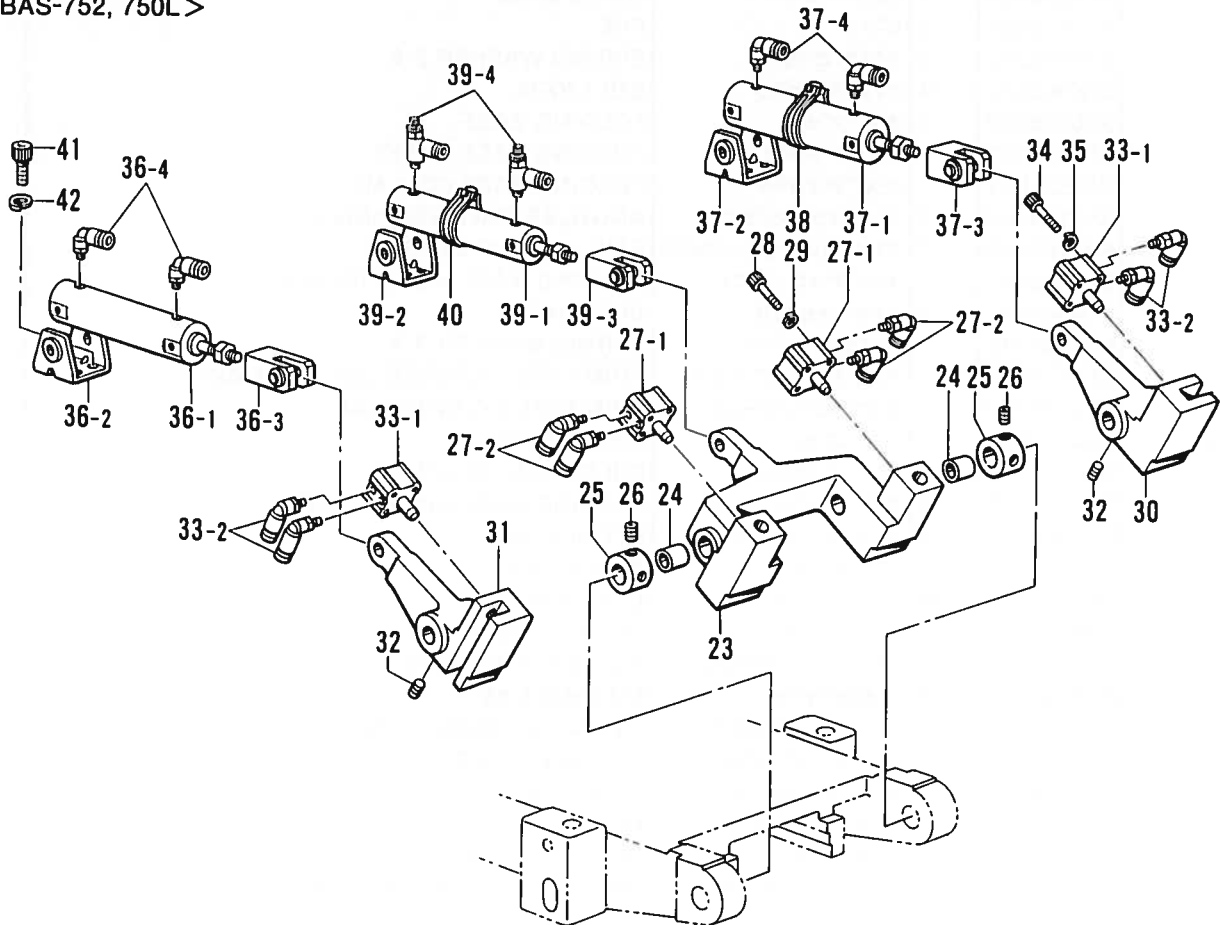

<BAS-754, 750KL>

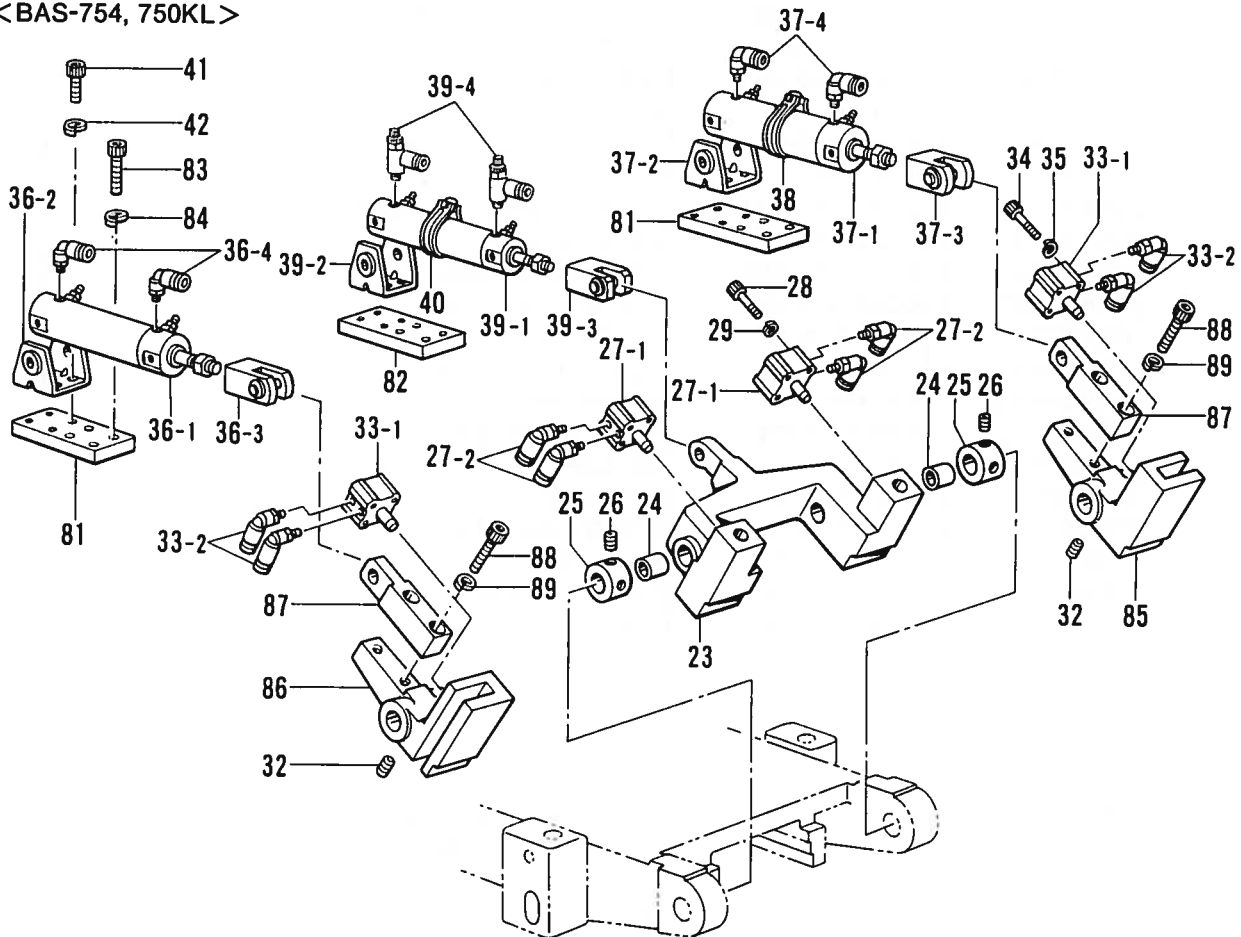

K2. 折曲ゲ土台関係/Folding margin base mechanism/Faltungsvorrichtungsgrundplatte/
Mécánisme de base de marge d'ourlet/Mecanismo base de margen de plegado

REF. NO.	CODE	Q'TY	ヒンメイ	NAME OF PARTS	RMKS
23	S12132009	1	ナカオサエレハ"	INNER CLAMP LEVER	
24	S12133000	2	フ"ツシユ1512	BUSH 1512	
25	S12134001	2	ナカオサエカラ	INNER CLAMP COLLAR	
26	014060632	4	アナトメ6X6クホ"ミ	SET SCREW 6X6	
27	S12135000	2	ロックシリンダ"ークミB	LOCK CYLINDER ASSEMBLY (B)	
27-1	S12052000	2	ロックシリンダ"	LOCK CYLINDER	
27-2	S11426000	4	エルボ"ユニオン4M5	ELBOW UNION 4M5	
28	S12053000	8	CQ2ホ"ルトM3X25	CQ2 BOLT M3X25	
29	028030243	8	ハ"ネサ"カ"ネ2-3	SPRING WASHER 2-3	
32	014060632	2	アナトメ6X6クホ"ミ	SET SCREW 6X6	
33	S12135000	2	ロックシリンダ"ークミB	LOCK CYLINDER ASSEMBLY (B)	
33-1	S12052000	2	ロックシリンダ"	LOCK CYLINDER	
33-2	S11426000	4	エルボ"ユニオン4M5	ELBOW UNION 4M5	
34	S12053000	8	CQ2ホ"ルトM3X25	CQ2 BOLT M3X25	
35	028030243	8	ハ"ネサ"カ"ネ2-3	SPRING WASHER 2-3	
38	S12271000	1	スイッチトリツクカナク"25	SWITCH SET METAL FITTINGS 25	
40	S11880000	1	スイッチトリツクカナク"20	SWITCH SET METAL FITTING 20	
41	018501222	12	アナホ"ルト5X12	BOLT 5X12	
42	028050242	12	ハ"ネサ"カ"ネ2-5	SPRING WASHER 2-5	
<BAS-752, 750L>					
30	S12136009	1	ア-ムR	ARM (R)	
31	S12137009	1	ア-ムL	ARM (L)	
36	S12138000	1	シリンダ"-25X50クミ	CYLINDER 25X50 ASSEMBLY	
36-1	S12140000	1	シリンダ"-25X50	CYLINDER 25X50	
36-2	S12139000	1	ヨウト"ウウケカナク"1	ROCK SUPPORT METAL FITTING 1	
36-3	S11994000	1	2ヤマナツクルシ"ヨイント1	KNUCKLE JOINT 1	
36-4	S11426000	2	エルボ"ユニオン4M5	ELBOW UNION 4M5	
37	S12141000	1	シリンダ"-25X50Sクミ	CYLINDER 25X50 (S) ASSEMBLY	
37-1	S12142000	1	シリンダ"-25X50S	CYLINDER 25X50 (S)	
37-2	S12139000	1	ヨウト"ウウケカナク"1	ROCK SUPPORT METAL FITTING 1	
37-3	S11994000	1	2ヤマナツクルシ"ヨイント1	KNUCKLE JOINT 1	
37-4	S11426000	2	エルボ"ユニオン4M5	ELBOW UNION 4M5	
39	S12144100	1	シリンダ"-20X50クミ	CYLINDER 20X50 ASSEMBLY	
39-1	S12146000	1	シリンダ"-20X50	CYLINDER 20X50	
39-2	S12145000	1	ヨウト"ウウケカナク"2	ROCK SUPPORT METAL FITTING 2	
39-3	S11988000	1	2ヤマナツクルシ"ヨイント2	KNUCKLE JOINT 2	
39-4	S15567000	2	スピコン(OUT)	SPEED CONTROLLER (OUT)	
<BAS-754, 750KL>					
36	S25064000	1	シリンダ"-25X75クミ	CYLINDER 25X75 ASSEMBLY	
36-1	S25063000	1	シリンダ"-25X75	CYLINDER 25X75	
36-2	S12139000	1	ヨウト"ウウケカナク"1	ROCK SUPPORT METAL FITTING 1	
36-3	S11994000	1	2ヤマナツクルシ"ヨイント1	KNUCKLE JOINT 1	
36-4	S11426000	2	エルボ"ユニオン4M5	ELBOW UNION 4M5	
37	S25062000	1	シリンダ"-25X75Sクミ	CYLINDER 25X75S ASSEMBLY	
37-1	S25061000	1	シリンダ"-25X75S	CYLINDER 25X75S	
37-2	S12139000	1	ヨウト"ウウケカナク"1	ROCK SUPPORT METAL FITTING 1	
37-3	S11994000	1	2ヤマナツクルシ"ヨイント1	KNUCKLE JOINT 1	
37-4	S11426000	2	エルボ"ユニオン4M5	ELBOW UNION 4M5	
39	S25066000	1	シリンダ"-20X65クミ	CYLINDER 20X65 ASSEMBLY	
39-1	S25065000	1	シリンダ"-20X65	CYLINDER 20X65	
39-2	S12145000	1	ヨウト"ウウケカナク"2	ROCK SUPPORT METAL FITTING 2	
39-3	S11988000	1	2ヤマナツクルシ"ヨイント2	KNUCKLE JOINT 2	
39-4	S15567000	2	スピコン(OUT)	SPEED CONTROLLER (OUT)	
81	S25068001	2	シリンダ"ササエオリ	CYLINDER SUPPORT FOLDING	
82	S25067001	1	シリンダ"-ササエナカ	CYLINDER SUPPORT CENTER	
83	018501622	12	アナホ"ルト5X16	BOLT 5X16	
84	028050242	12	ハ"ネサ"カ"ネ2-5	SPRING WASHER 2-5	
85	S25070009	1	ア-ムRN	ARM (RN)	
86	S25071009	1	ア-ムLN	ARM (LN)	
87	S25069001	2	ア-ムツキ"テ	ARM JOINT	
88	018502022	4	アナホ"ルト5X20	BOLT 5X20	
89	028050242	4	ハ"ネサ"カ"ネ2-5	SPRING WASHER 2-5	

L. カマ関係 / Rotary hook mechanism / Greifervorrichtung /
 Mécanisme du crochet rotatif / Mecanismo del cangrejo

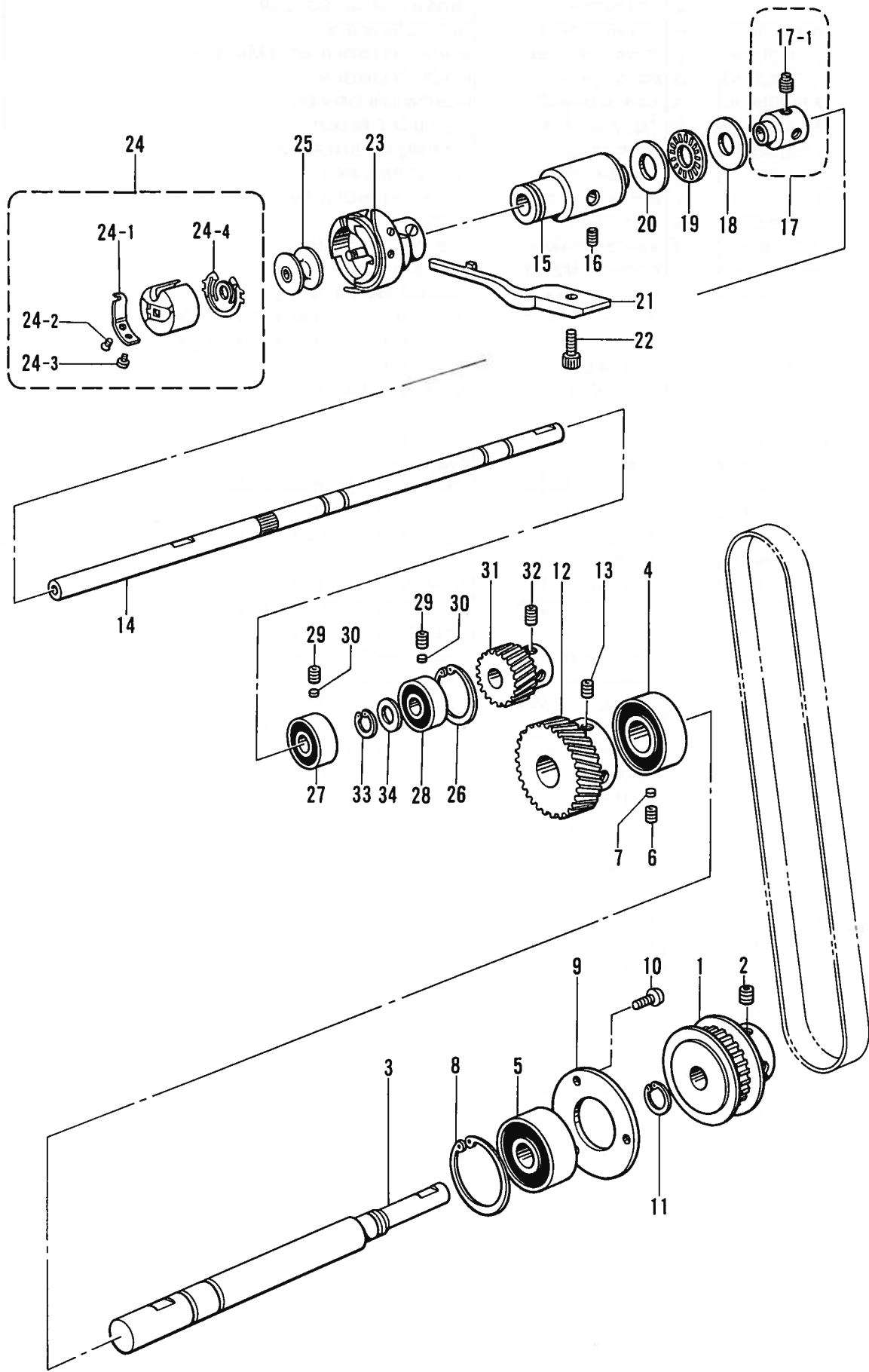

L. カマ関係/Rotary hook mechanism/Greifervorrichtung/
Mécanisme du crochet rotatif/Mecanismo del cangrejo

REF.NO.	CODE	Q'TY	ヒンメイ	NAME OF PARTS	RMKS
1	S11891001	1	タイミングプーリD	TIMING PULLEY (D)	
2	014770622	2	アナトメネジ"6.35クホ"ミ	SET SCREW 6.35	
3	S11892001	1	シタシ"ク	LOWER SHAFT	
4	S11921000	1	タマシ"クウケ6002DDU	BALL BEARING 6002DDU	
5	S11923000	1	タマシ"クウケ6300DDU	BALL BEARING 6300DDU	
6	014400822	1	アナトメネジ"4クホ"ミ	SET SCREW 4	
7	S01234000	1	サ"カ"ネ	WASHER	
8	048350242	1	トメワアナヨウC35	STOP RING C35	
9	S11893001	1	タマシ"クウケオサエ	BALL BEARING PRESSER	
10	062401012	3	ナヘ"COM4X10	SCREW M4X10	
11	048100142	1	トメワシ"クヨウC10	STOP RING C10	
12	S11894001	1	スハ"イラルキ"ヤ	SPIRAL GEAR	
13	014770622	3	アナトメネジ"6.35クホ"ミ	SET SCREW 6.35	
14	S24902001	1	カマシ"ク	ROTARY HOOK SHAFT	
15	S11896001	1	カマシ"クメタル	ROTARY HOOK SHAFT BUSH	
16	014400822	1	アナトメネジ"4クホ"ミ	SET SCREW 4	
17	183532001	1	セツカ"ラ"ク"ミ	SET COLLAR ASSEMBLY	
17-1	101706001	2	トメネジ"6.35	SET SCREW 6.35	
18	S11898000	1	キト"ウ"リン	DRIVE TUMBLER	
19	S11899000	1	ニート"ル"ハ"ア"リ"ン"ク"	NEEDLE BEARING	
20	115007001	1	サ"カ"ネ	WASHER	
21	159324001	1	ウチカ"マ"ト"メ	BOBBIN CASE HOLDER POSITION BRACKET	
22	018401222	1	アナホ"ル"ト4X12	BOLT 4X12	
23	S16170001	1	コウソク"カ"マ	ROTARY HOOK ASSEMBLY	
24	S03245001	1	ホ"ヒ"ン"ケ"ー"ス"ク"ミ	BOBBIN CASE ASSEMBLY	
24-1	183388001	1	ホ"ヒ"ン"ケ"ー"ス"チ"ヨ"ウ"シ"ハ"ネ	TENSION SPRING	
24-2	183389001	1	チ"ヨ"ウ"シ"ハ"ネ"チ"ヨ"ウ"セ"ツ"ネ"ジ"	ADJUST SCREW	
24-3	183390001	1	チ"ヨ"ウ"シ"ハ"ネ"ト"メ"ネ"ジ"	SET SCREW	
24-4	S03246001	1	ク"ウ"テン"ホ"ウ"シ"ハ"ネ	BOBBIN TENSION SPRING	
25	146290001	1	ホ"ヒ"ン	BOBBIN	
26	048220242	1	トメワアナヨウC22	STOP RING C22	
27	072060860	1	タマシ"クウケ608VV	BALL BEARING 608VV	
28	S11924000	1	タマシ"クウケ608DDW1	BALL BEARING 608DDW1	
29	014400822	2	アナトメネジ"4クホ"ミ	SET SCREW 4	
30	S01234000	2	サ"カ"ネ	WASHER	
31	S11900001	1	ヒ"ニ"オ"ン	PINION	
32	014770622	3	アナトメネジ"6.35クホ"ミ	SET SCREW 6.35	
33	048080142	1	トメワシ"クヨウC8	STOP RING C8	
34	S01040001	1	サ"カ"ネ	WASHER	

M. 糸切れ感知関係 / Thread breakage detector mechanism / Fadenbruchfühler /
 Mécanisme du détecteur de cassure du fil / Mecanismo del sensor de cortes de hilo

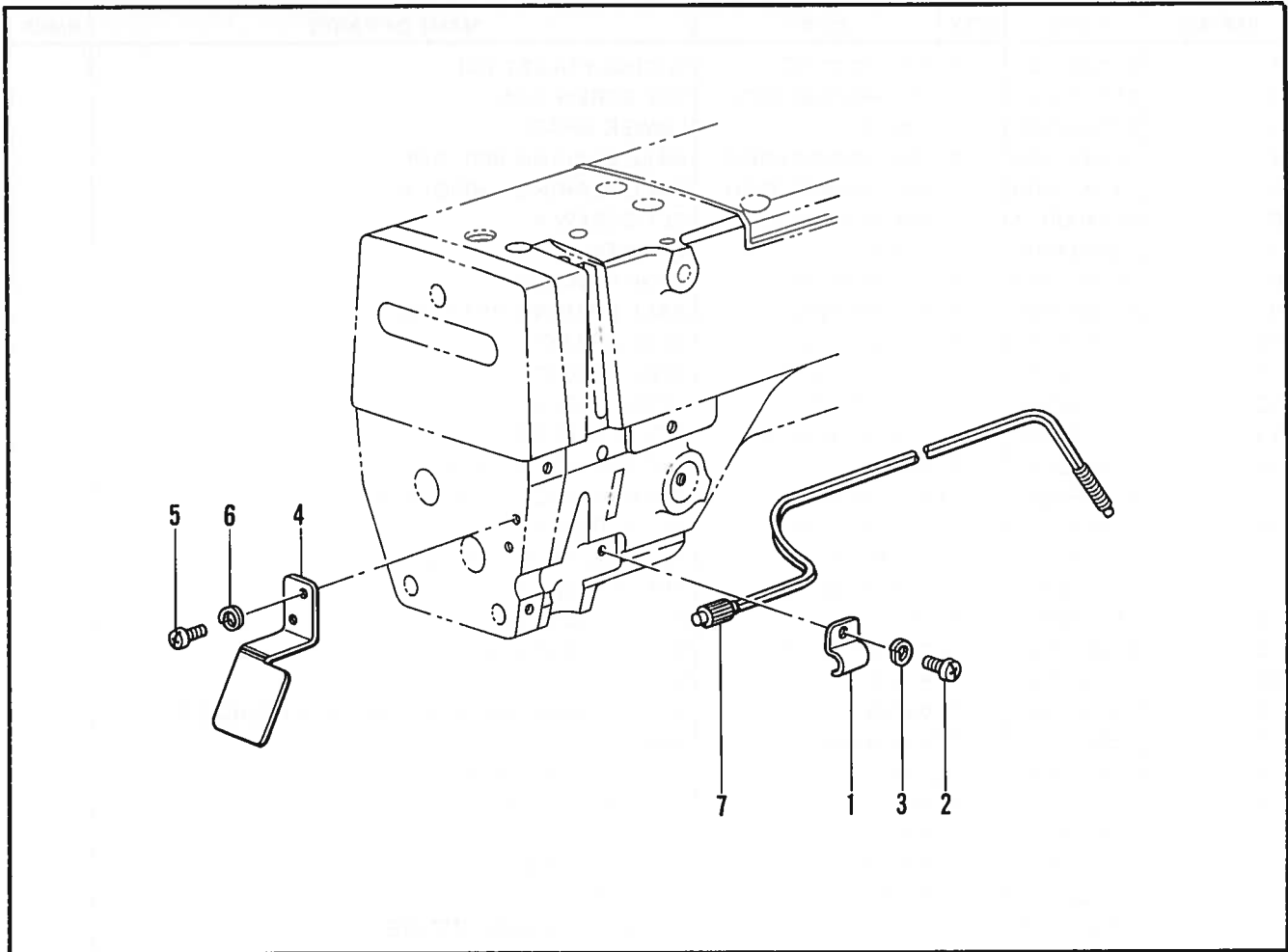

N1. 給油潤滑関係 / Lubrication / Schmierung /
 Lubrification / Lubricación

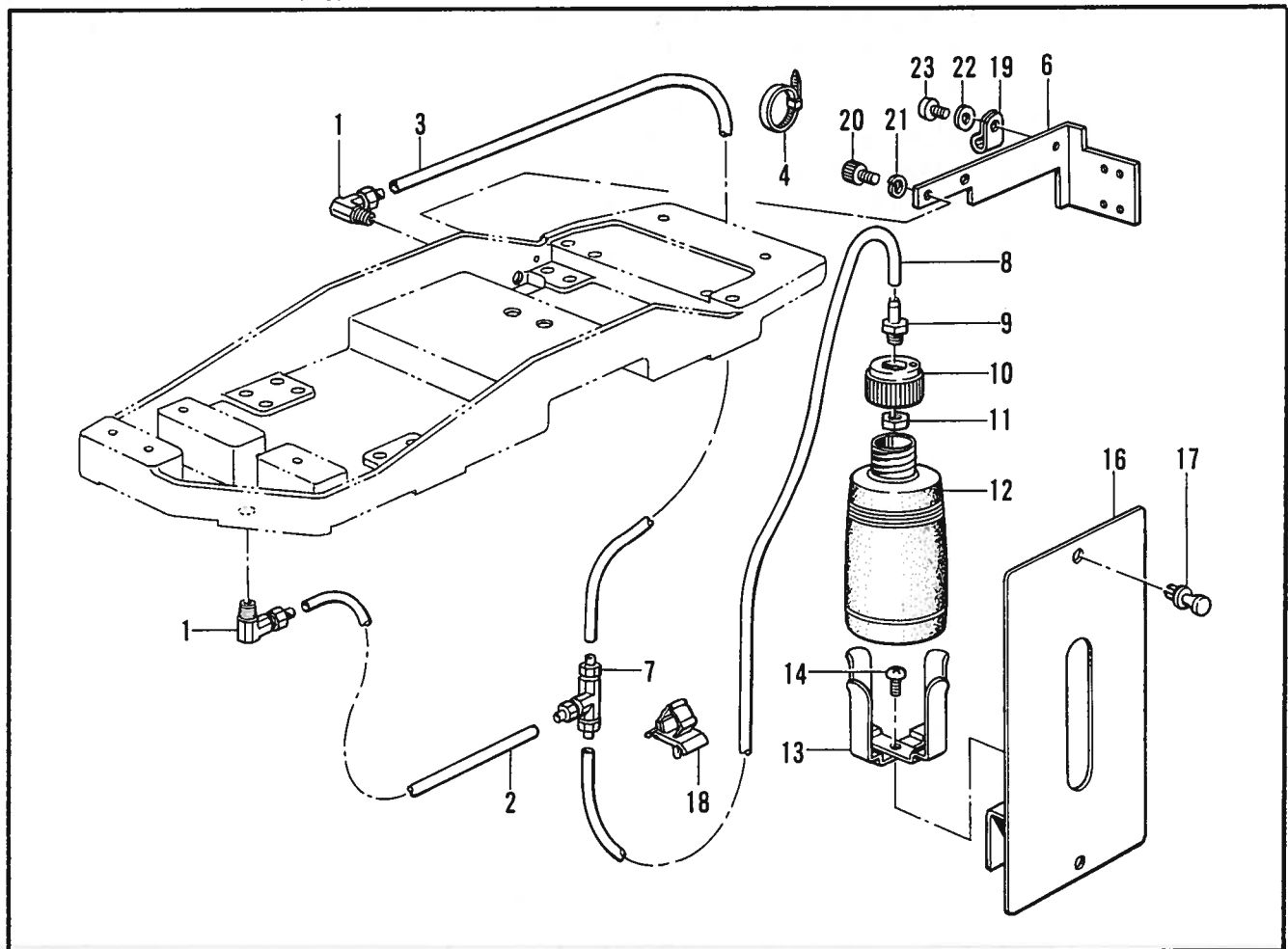

M. 糸切れ感知関係 / Thread breakage detector mechanism / Fadenbruchfühler /
 Mécanisme du détecteur de cassure du fil / Mecanismo del sensor de cortes de hilo

REF. NO.	CODE	Q'TY	ヒンメイ	NAME OF PARTS	RMKS
1	S11884001	1	センサーリツケイタ	SENSOR SET PLATE	
2	062300612	1	ナヘ"コ3X6	SCREW 3X6	
3	028030242	1	ハ"ネサ"カ"ネ2-3	SPRING WASHER 2-3	
4	S11885001	1	センサーカバー	SENSOR COVER	
5	062300612	2	ナヘ"コ3X6	SCREW 3X6	
6	028030242	2	ハ"ネサ"カ"ネ2-3	SPRING WASHER 2-3	
7	S11886000	1	ファイバ"ユニット	FIBER UNIT	

N1. 給油潤滑関係 / Lubrication / Schmierung /
 Lubrification / Lubricación

REF. NO.	CODE	Q'TY	ヒンメイ	NAME OF PARTS	RMKS
1	S12043000	2	エルボ"ユニオン	ELBOW UNION	
2	S11946000	1	ヒ"ニルチューブ"(L=1350)	OIL TUBE (L=1350)	
3	S11947000	1	ヒ"ニルチューブ"(L=800)	OIL TUBE (L=800)	
4	S04159000	2	バンド"1M	BAND 1M	
6	S19523201	1	チューブ"ササエ	TUBE SUPPORT	
7	S12483000	1	チース"ユニオン	T-UNION	
8	S12484000	1	ヒ"ニルチューブ"(L=350)	OIL TUBE (L=350)	
9	154468001	1	ハイユク"チ	OIL FEEDING	
10	144508001	1	ホ"リオイル"ノス"ルトメ	CAP	
11	106147002	1	ナツト"7.94	NUT 7.94	
12	114486002	1	ホ"リオイル"タイ	OILER	
13	133172003	1	アブ"ラサシ"タイ	OIL BRACKET	
14	008400806	1	トラス"コ4X8	SCREW 4X8	
16	S12482009	1	オイル"タイトリツケイタ	OILER SET PLATE	
17	S12481000	2	ナイラツ"チ	NYLATCH	
18	S11848000	1	コード"クランプ"＃7	CORD CLAMP 7N	
19	149547000	1	コード"オサエ"(4N)	CORD HOLDER (4N)	
20	018400832	2	アナホ"ルト4X8	BOLT 4X8	
21	028040242	2	ハ"ネサ"カ"ネ2-4	SPRING WASHER 2-4	
22	025040233	1	ヒラサ"カ"ネチユウ4	PLAIN WASHER 4	
23	062400806	1	ナヘ"コ4X8	SCREW M4X8	

N2. 給油潤滑関係 / Lubrication / Schmierung /
Lubrification / Lubricación

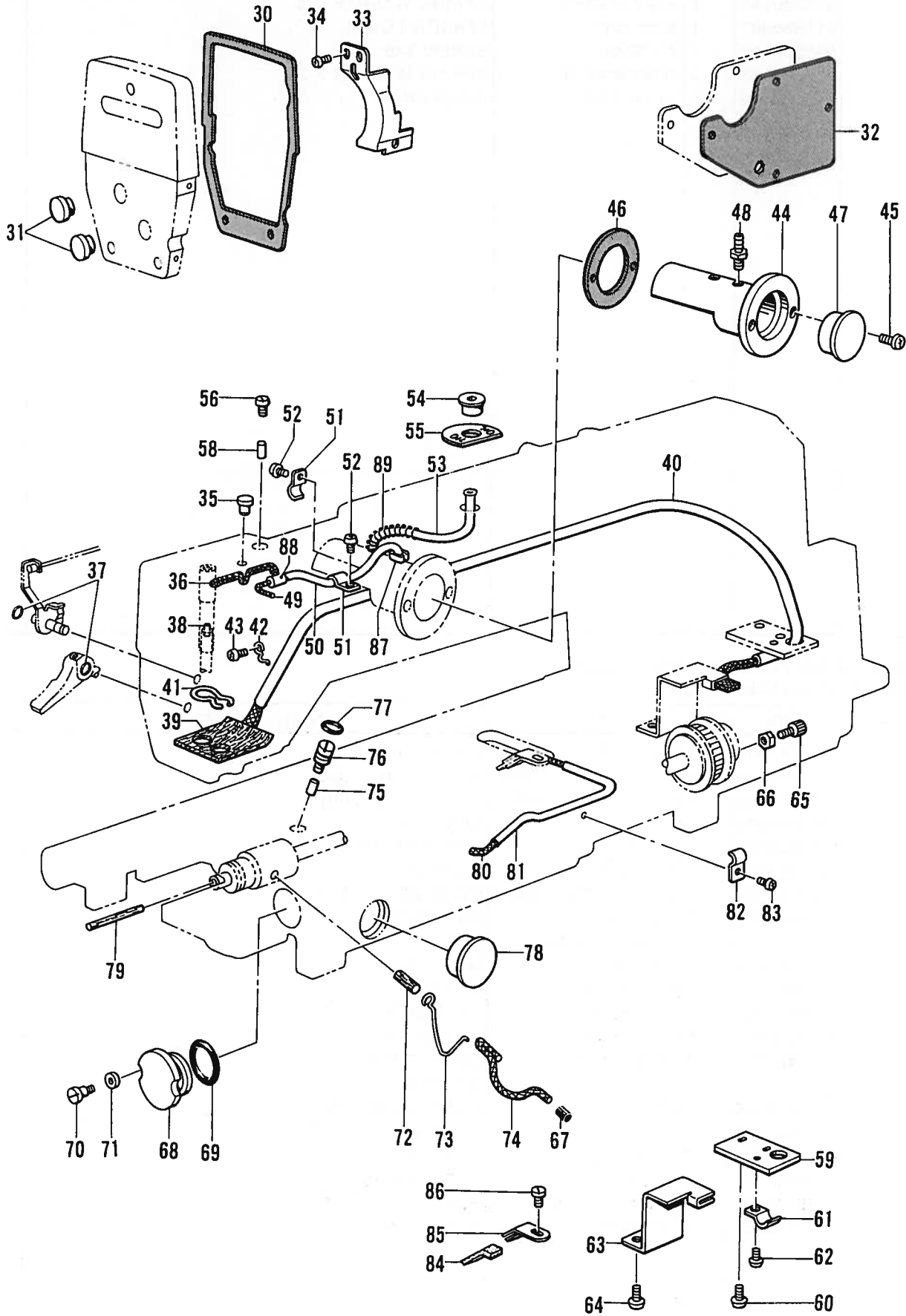

N2. 給油潤滑関係/Lubrication/Schmierung/
Lubrication/Lubricación

REF.NO.	CODE	Q'TY	ヒンメイ	NAME OF PARTS	RMKS
30	S11901100	1	メンイタハツキン	PACKING	
31	104449009	2	メクラセン	OIL CAP	
32	S11902000	1	ガクイタハツキン	REAR COVER PACKING	
33	S07229101	1	テンピンオイルヨケイタ	OIL STOPPER PLATE	
34	062670512	2	ナヘ"コ357-40X5	SCREW 357X5	
35	111865009	1	オイルメクラセン	OIL CAP	
36	108804001	1	クミヒモ4X4(L=510)	WICK 4X4 (L=510)	
37	081001670	2	Oリング"PW1	O RING PW1	
38	111863001	1	ハリホ"ウセン	NEEDLE BAR CORK	
39	S11903000	1	スイアゲ"フェルトクミ	FELT ASSEMBLY	
40	S11906000	1	ヒ"ニルチューブ"	OIL TUBE	
41	145737001	1	フェルトオサエ	FELT SUPPORT	
42	117150001	1	コート"ササエカネ	CORD SUPPORT	
43	062670512	1	ナヘ"コ357-40X5	SCREW 357X5	
44	S11907009	1	オイルタンク	OIL TANK	
45	062401012	2	ナヘ"コM4X10	SCREW M4X10	
46	S11908000	1	オイルタンクハツキン	OIL TANK PACKING	
47	152948001	1	オイルホ"ツトマト"	OIL GAUGE WINDOW	
48	142359001	2	オイルクチ	OIL FEEDING PIPE	
49	S11909000	1	クミヒモ3X3(L=250)	WICK 3X3 (L=250)	
50	S11910000	1	ヒ"ニルチューブ"(L=115)	OIL TUBE (L=115)	
51	140647001	2	コート"オサエ	CORD HOLDER	
52	062300612	2	ナヘ"コ3X6	SCREW 3X6	
53	S11945000	1	ヒ"ニルチューブ"(L=100)	OIL TUBE (L=100)	
54	112758009	1	ハ"ツト"オイルフタ	OIL CAP	
55	S11911009	1	オイルシート	OIL SEAT	
56	145619001	1	シメネジ"6.35	SCREW 6.35	
58	S07478000	1	ゴムオサエ	RUBBER PRESSER	
59	S11912001	1	チューブ"アンナイ	TUBE GUIDE	
60	062400812	2	ナヘ"コ4X8	SCREW 4X8	
61	140647001	1	コート"オサエ	CORD HOLDER	
62	062300612	1	ナヘ"コ3X6	SCREW 3X6	
63	S11913001	1	キユウユササエ	OIL SUPPORT	
64	062400812	2	ナヘ"コ4X8	SCREW 4X8	
65	018401622	1	アナホ"ルト4X16	BOLT 4X16	
66	021400202	1	2シユナツト4	NUT 4	
67	157843001	1	ゴムセン6X6	OIL CAP 6X6	
68	157844000	1	アブ"ラマト"	OIL GAUGE WINDOW	
69	081024070	1	Oリング"P24	O RING P24	
70	153112001	2	タ"ンネジ"3.57	STUD SCREW 3.57	
71	140208001	2	サ"カ"ネ	WASHER	
72	S11915000	1	フェルト5X16	FELT 5X16	
73	S11916001	1	クミヒモササエ	WICK SUPPORT	
74	157840000	1	クミヒモ3X3(L=100)	WICK 3X3 (L=100)	
75	S07478000	1	ゴムオサエ	RUBBER PRESSER	
76	S11917001	1	オイルチヨウセツネジ"	ADJUST SCREW	
77	081005670	1	Oリング"PW5	O RING PW5	
78	152948001	1	オイルホ"ツトマト"	OIL GAUGE WINDOW	
79	S11918000	1	フェルト	FELT	
80	S11909000	1	クミヒモ3X3(L=250)	WICK 3X3 (L=250)	
81	S11919000	1	ヒ"ニルチューブ"(L=160)	OIL TUBE (L=160)	
82	140647001	1	コート"オサエ	CORD HOLDER	
83	062300612	1	ナヘ"コ3X6	SCREW 3X6	
84	S11914000	1	フェルト	FELT	
85	S11920001	1	フェルトササエ	FELT SUPPORT	
86	106629002	1	シメネジ"4.37	SCREW 4.37	
87	S07469001	1	チューブ"カシメ	TUBE CALKING	
88	S11944000	1	ゴムリング"	RUBBER RING	
89	144086001	1	オサエホ"ウアケ"ハ"ネ	SPRING	
87	S25069001	2	アームツキ"テ	ARM JOINT	

P. 糸通シ関係 / Threading mechanism / FadenführungsVorrichtung /
 Mécanisme de l'enfilage / Mecanismo del enhebrado

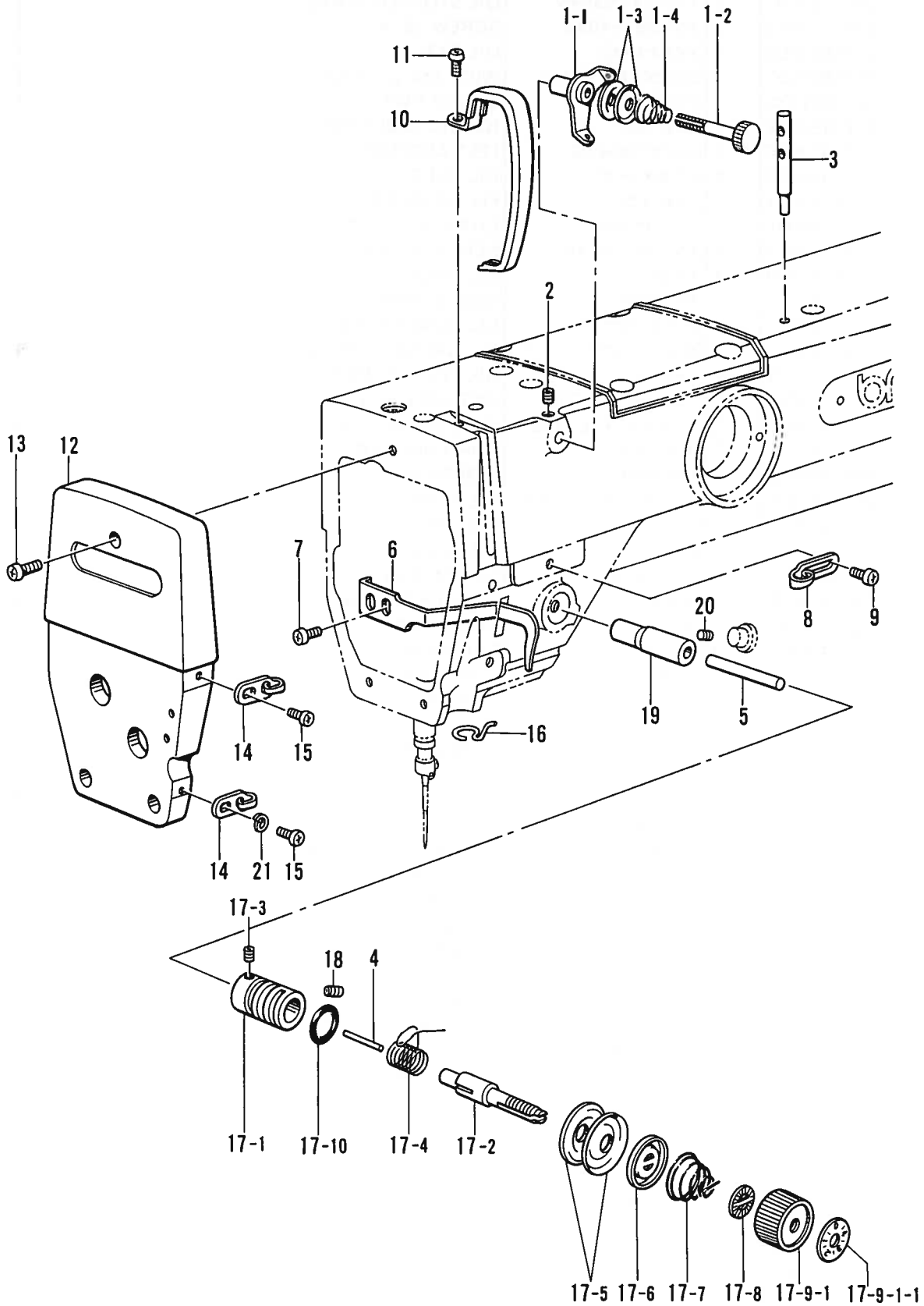

P. 糸通シ関係/Threading mechanism/Fadenführungsrichtung/
Mécánisme de l'enfilage/Mecanismo del enhebrado

REF.NO.	CODE	Q'TY	ヒンメイ	NAME OF PARTS	RMKS
1	183377001	1	フレンションクミ	PRE-TENSION ASSEMBLY (A)	
1-1	S02611001	1	イトアンナイ	THREAD GUIDE	
1-2	S02612001	1	イトアンナイチヨウシホ"ウ	PRE-TENSION STUD	
1-3	144504001	2	イトアンナイサラ	THREAD GUIDE DISC	
1-4	154560001	1	フレンションハ"ネA	PRE-TENSION SPRING (A)	
2	014400522	1	アナクホ"ミ4X5	SET SCREW 4X5	
3	147557101	1	イトタテホ"ウ	SPOOL PIN	
4	100400000	1	イトユルメピン	PIN	
5	S07972001	1	イトユルメホ"ウ	TENSION RELEASE STUD	
6	111469101	1	オサエホ"ウタ"キイトアンナイ	THREAD GUIDE	
7	062680712	1	ナヘ"コ437-40X7	SCREW 437X7	
8	145522001	1	アームイトアンナイR	ARM THREAD GUIDE (R)	
9	060670612	1	ハ"イント"357-40X6	SCREW 357X6	
10	S02614109	1	テンヒ"ンカハ"ー	THREAD TAKE-UP COVER	
11	062400812	1	ナヘ"コ4X8	SCREW 4X8	
12	S11925109	1	メンイタ	FACE PLATE	
13	062401012	3	ナヘ"コM4X10	SCREW M4X10	
14	S02617001	2	メンイタイトアンナイ	FACE PLATE THREAD GUIDE	
15	060670612	2	ハ"イント"357-40X6	SCREW 357X6	
16	100573001	1	ハリホ"ウメタルDイトアンナイ	NEEDLE BAR BUSH (D) THREAD GUIDE	
17	183513009	1	イトチヨウシホ"ウタ"イクミ	THREAD TENSION BRACKET ASSEMBLY	
17-1	S03254001	1	イトチヨウシホ"ウタイ	THREAD TENSION BRACKET	
17-2	116922001	1	イトチヨウシホ"ウ	TENSION STUD	
17-3	100402004	1	トメネシ"3.57	SET SCREW 3.57	
17-4	S02620001	1	イトトリハ"ネ	SPRING	
17-5	145446001	2	イトチヨウシサラ	TENSION DISC	
17-6	159805001	1	イトチヨウシサラオサエ	TENSION DISC PRESSER	
17-7	104525001	1	イトチヨウシハ"ネ	TENSION SPRING	
17-8	S02624001	1	チヨウシハ"ネウエサ"カ"ネ	WASHER	
17-9	S11182009	1	イトチヨウシナツクミ	THREAD TENSION NUT ASSEMBLY	
17-9-1	S11183009	1	チヨウセツツマミ	CONTROL DIAL	
17-9-1-1	S11184009	1	イトチヨウシメモリイタ	TENSION ADJUST SCALE PLATE	
17-10	114294001	1	Oリング"	O RING	
18	103950003	1	トメネシ"5.95	SET SCREW 5.95	
19	S07901000	1	イトユルメメタル	TENSION RELEASE BUSH	
20	014400822	1	アナトメネシ"4クホ"ミ	SET SCREW 4	
21	028350242	1	ハ"ネサ"カ"ネ2-3.5	SPRING WASHER 2-3.5	

Q. 糸巻キ関係/Bobbin winder mechanism/Spuler/
 Mécanisme du bobineur/Mecanismo del devanador de la canilla

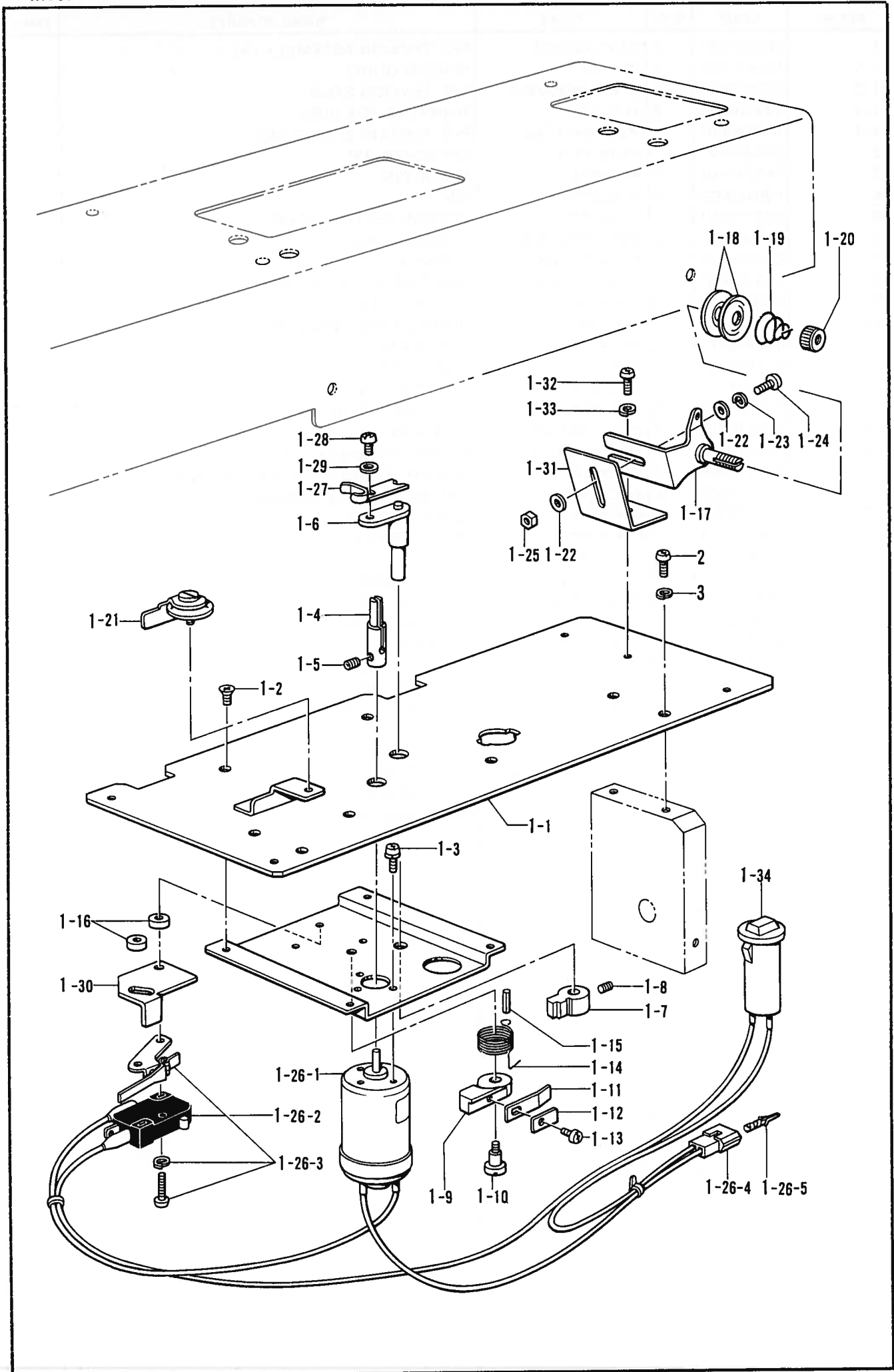

Q. 糸巻キ関係/Bobbin winder mechanism/Spuler/
Mécanisme du bobineur/Mecanismo del devanador de la canilla

REF.NO.	CODE	Q'TY	ヒンメイ	NAME OF PARTS	RMKS
1	S17701009	1	イトマキソウチクミ	BOBBIN WINDER EQUIPMEINT ASSEMBLY	
1-1	S12027109	1	イトマキヘ"ース	BOBBIN WINDER BASE	
1-2	004300513	4	+ サラコ3X5	SCREW 3X5	
1-3	215083001	3	+ ナヘ"セツト3X6D	WASHER SCREW 3X6D	
1-4	152358001	1	イトマキシ"ク	BOBBIN WINDER SHAFT	
1-5	014300332	2	アナクホ"ミ3X3	SET SCREW 3X3	
1-6	154024001	1	ホ"ヒ"ンオサエ	BOBBIN PRESSER	
1-7	154092001	1	イトマキツメタ"ンツキ	BOBBIN WINDER CLAW	
1-8	014680422	2	アナトメネシ"4.37クホ"ミ	SET SCREW 4.37	
1-9	152361001	1	イトマキレハ"ー	BOBBIN WINDER LEVER	
1-10	152362001	1	イトマキタ"ンネジ"	BOBBIN WINDER STUD SCREW	
1-11	111942001	1	イタハ"ネ	PLATE SPRING	
1-12	111943001	1	イタハ"ネサ"カ"ネ	PLATE SPRING WASHER	
1-13	060660512	1	ハ"イント"318-40X5	SCREW 318X5	
1-14	152363001	1	ネシ"リハ"ネA	TWIST SPRING (A)	
1-15	047301042	1	スフ"リンク"ヒ"ン	SPRING PIN	
1-16	152364001	2	カラ"ー	COLLAR	
1-17	145571101	1	イトマキアンナイダ"イクミ	BOBBIN WINDER GUIDE BRACKET ASSEMBLY	
1-18	145446001	2	イトチヨウシサラ	TENSION DISC	
1-19	100401001	1	イトチヨウシハ"ネ	TENSION SPRING	
1-20	100136001	1	イトチヨウシナツト	TENSION NUT	
1-21	146197001	1	イトツカミクミ	THREAD CLAMP ASSEMBLY	
1-22	025040232	2	ヒラサ"カ"ネチユウ4	PLAIN WASHER 4	
1-23	028040242	1	ハ"ネサ"カ"ネ2-4	SPRING WASHER 2-4	
1-24	062401012	1	ナヘ"コM4X10	SCREW M4X10	
1-25	021400202	1	2シユナツト4	NUT 4	
1-26	S19522001	1	イトマキモ"ータクミ	BOBBIN WINDER GUIDE BRACKET ASSEMBLY	
1-26-1	S16667000	1	イトマキモ"ータ	BOBBIN WINDER MOTOR	
1-26-2	152507000	1	マイクロスイッチD	MICRO SWITCH (D)	
1-26-3	152508000	1	マイクロアクチエ"ータ	MICRO ACTUATOR	
1-26-4	152509000	1	ナイロンコネクタE	NYLON CONNECTOR (E)	
1-26-5	552851001	2	ピンター"ミナル#1854	TERMINAL PIN #1854	
1-27	152645001	1	ホ"ヒ"ンオサエイタ	BOBBIN HOLD PLATE	
1-28	062300616	1	ナヘ"コM3X6	SCREW M3X6	
1-29	025030233	1	ヒラサ"カ"ネチユウ3	PLAIN WASHER 3	
1-30	158597001	1	イトマキストツハ"ー	BOBBIN WINDER STOPPER	
1-31	158598009	1	イトマキアンナイトリツケイタ	BOBBIN WINDER GUIDE SET PLATE	
1-32	062401012	1	ナヘ"コM4X10	SCREW M4X10	
1-33	028040242	1	ハ"ネサ"カ"ネ2-4	SPRING WASHER 2-4	
1-34	S16669000	1	プロテクタ0.5A	PROTECTOR 0.5A	
2	062400806	4	ナヘ"コ4X8	SCREW M4X8	
3	028040243	4	ハ"ネサ"カ"ネ2-4	SPRING WASHER 2-4	

R. 糸切り関係 / Thread trimmer mechanism / Fadenabschneidevorrichtung /
 Mécanisme de coupe-fil / Mecanismo de la cortadura de hilos

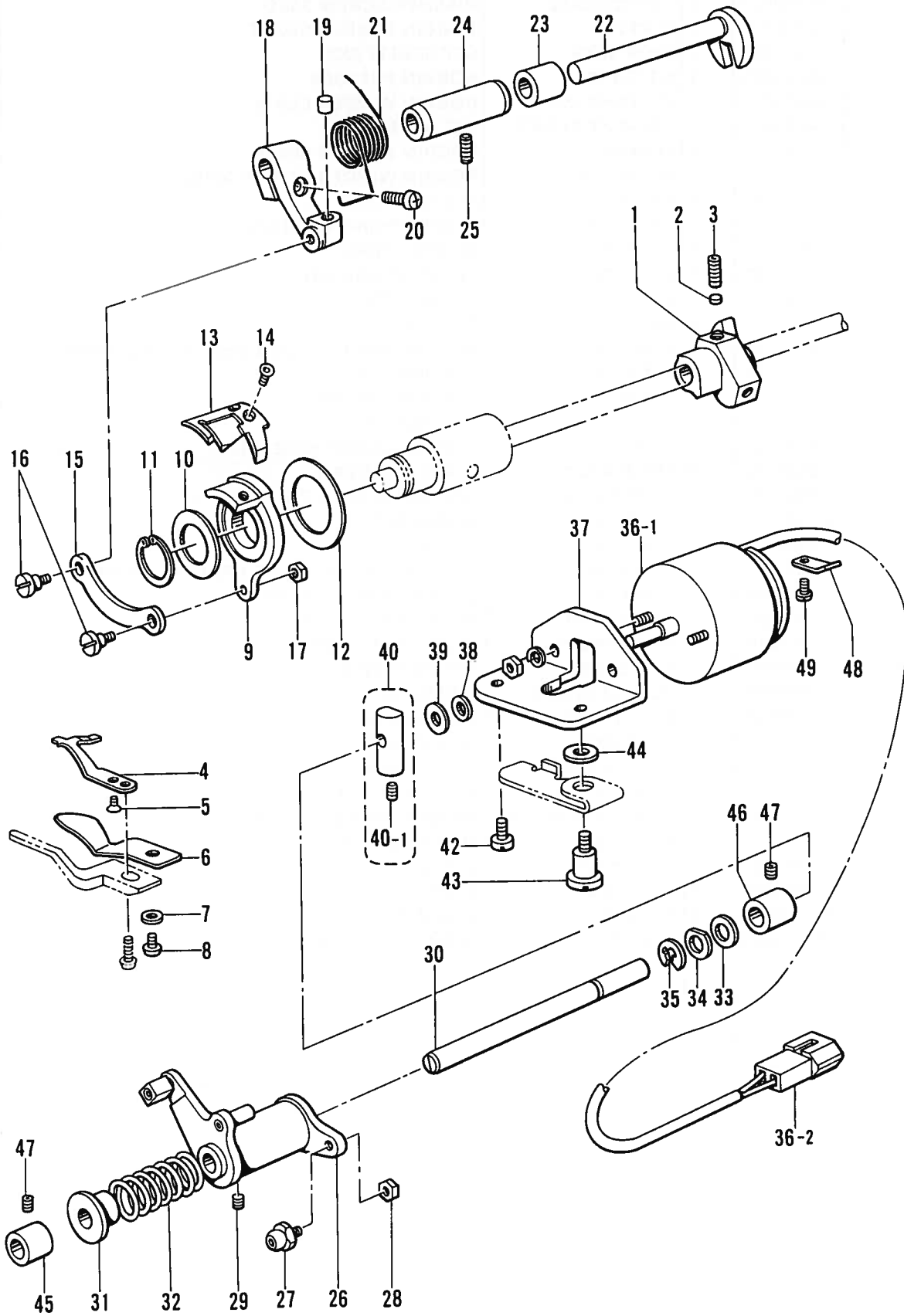

R. 糸切り関係/Thread trimmer mechanism/Fadenabschneidevorrichtung/
Mécánisme de coupe-fil/Mecanismo de la cortadura de hilos

REF.NO.	CODE	Q'TY	ヒンメイ	NAME OF PARTS	RMKS
1	S00337001	1	イトキリカム	THREAD TRIMMER CAM	
2	154567000	2	カンサ"5.3	WASHER 5.3	
3	014771022	2	アナトメネジ"6.35クホ"ミ	SET SCREW 6.35	
4	S02637001	1	コテイハ	FIXED KNIFE	
5	102843004	1	サラネジ"3.57	SCREW 3.57	
6	S02643001	1	イトサハ"キ	LOWER THREAD FINGER	
7	100645003	1	サ"ガ"ネ	WASHER	
8	062400812	1	ナヘ"コ4X8	SCREW 4X8	
9	156619001	1	イトキリホルダ"	MOVABLE KNIFE HOLDER	
10	156620000	1	スラストサ"ガ"ネ	THRUST WASHER	
11	048170145	1	トメワジ"クヨウC17	STOP RING C17	
12	S11926001	1	サ"ガ"ネ	WASHER	
13	S02645001	1	イト"ウハ	MOVABLE KNIFE	
14	148537001	2	サラネジ"4.37	SCREW 4.37	
15	154576001	1	イトキリレンカン	THREAD TRIMMER CONNECTING ROD	
16	151987001	2	タ"ンネジ"4.37	STUD SCREW 4.37	
17	102571003	1	ナツト4.37	NUT 4.37	
18	154577001	1	イトキリレハ"ー	THREAD TRIMMER LEVER	
19	154578000	1	レハ"ー"ストツハ"	THREAD TRIMMER LEVER STOPPER	
20	062711412	1	ナヘ"コ4.76-32X14	SCREW 476X14	
21	154579001	1	イトキリレハ"ー"ハ"ネ	SPRING	
22	S02647001	1	フタマタジ"ク	FORKED SHAFT	
23	S02648001	1	カラ"ー	COLLAR	
24	154581001	1	フタマタジ"ク"メタル	FORKED SHAFT BUSH	
25	014400822	1	アナトメネジ"4クホ"ミ	SET SCREW 4	
26	154582001	1	イトキリカムレハ"ー"クミ	THREAD TRIMMER CAM LEVER ASSEMBLY	
27	154590001	1	コロジ"ク"クミ	ROLLER SHAFT (C) ASSEMBLY	
28	105234003	1	ナツト4.37	NUT 4.37	
29	100251001	1	トメネジ"6.35	SET SCREW 6.35	
30	154593001	1	イトキリカムレハ"ー"ジ"ク	THREAD TRIMMER CAM LEVER SHAFT	
31	154594000	1	カラ"ー	COLLAR	
32	154595001	1	カムレハ"ー"モト"シハ"ネ	SPRING	
33	154596000	1	イトキリカムレハ"ー"クツシヨ"ン	CUSHION	
34	110367001	1	サ"ガ"ネ	WASHER	
35	048060342	1	トメワE6	STOP RING E6	
36	S11927009	1	イトキリソレノイト"クミ	THREAD TRIMMER SOLENOID ASSEMBLY	
36-1	S11928009	1	イトキリソレノイト"	THREAD TRIMMER SOLENOID	
36-2	143488000	1	ナイロンコネクター	NYLON CONNECTOR	
37	154598001	1	イトキリソレノイト"ダ"イ	THREAD TRIMMER SOLENOID BRACKET	
38	154599000	1	ソレノイト"クツシヨ"ン	SOLENOID CUSHION	
39	S02652001	1	サ"ガ"ネ	WASHER	
40	S23836001	1	ソレノイト"レハ"ー"クミ	SOLENOID LEVER ASSEMBLY	
40-1	014680622	1	アナトメネジ"4.37クホ"ミ	SET SCREW 4.37	
42	110201001	1	シメネジ"6.35	SCREW 6.35	
43	S02655001	1	タ"ンネジ"6.35	STUD SCREW 6.35	
44	155559001	1	ヒラサ"ガ"ネ	PLAIN WASHER	
45	S11929001	1	イトキリシ"ク"メタルL	THREAD TRIMMER SHAFT BUSH (L)	
46	S11930001	1	イトキリシ"ク"メタルR	THREAD TRIMMER SHAFT BUSH (R)	
47	014400822	2	アナトメネジ"4クホ"ミ	SET SCREW 4	
48	S02657001	1	コート"オ"サ"エ	CORD HOLDER	
49	062300612	1	ナヘ"コ3X6	SCREW 3X6	

S. 糸ユルメ関係/Tension release mechanism/Spannungsverminderungsvorrichtung/
 Mécanisme de la lâche de tension/Mecanismo relajador de tensión

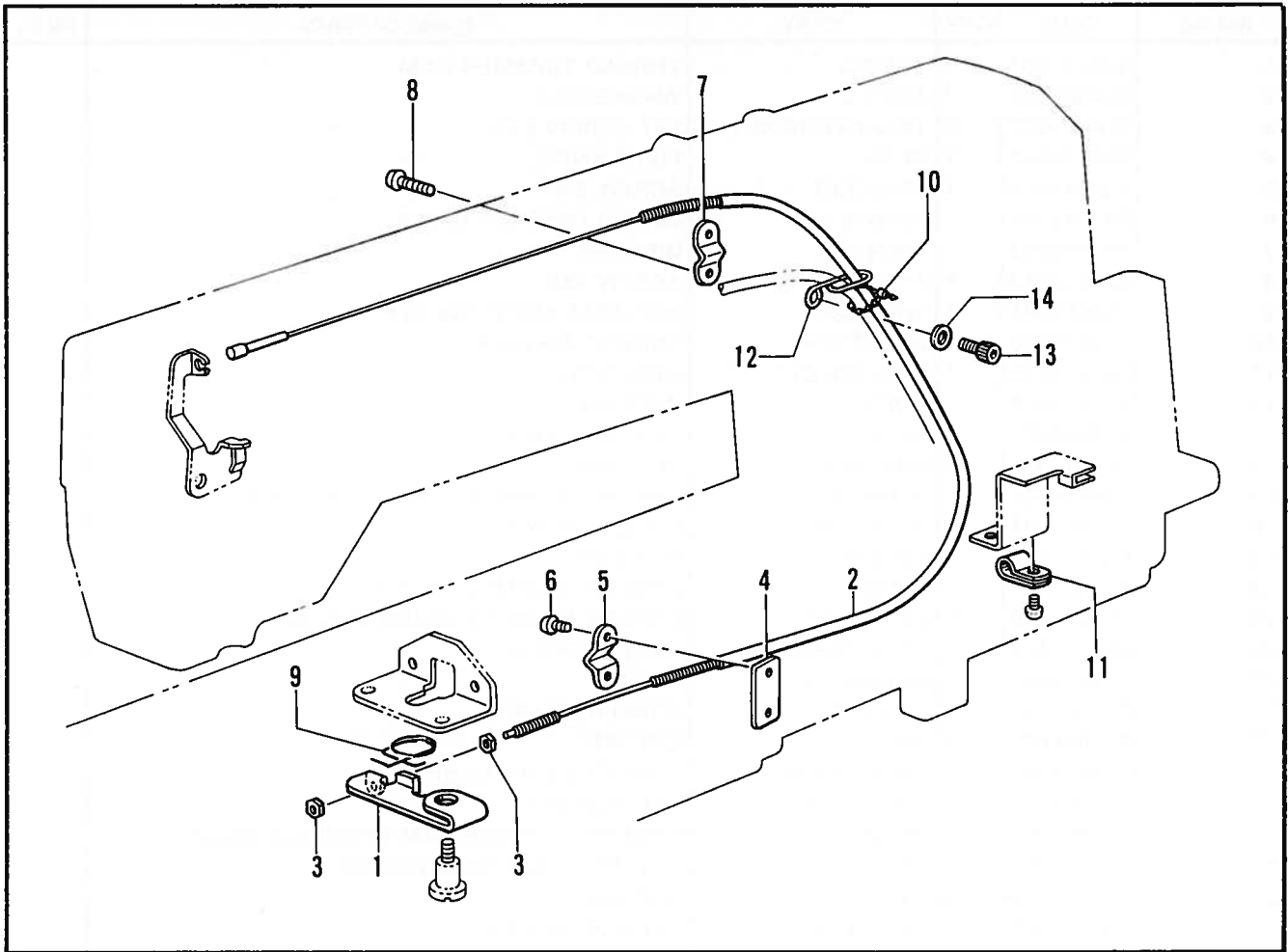

T. 踏板関係/Foot switch pedal mechanism/Fußbetätigung/
 Mécanisme de la pédale/Mecanismo del pedal

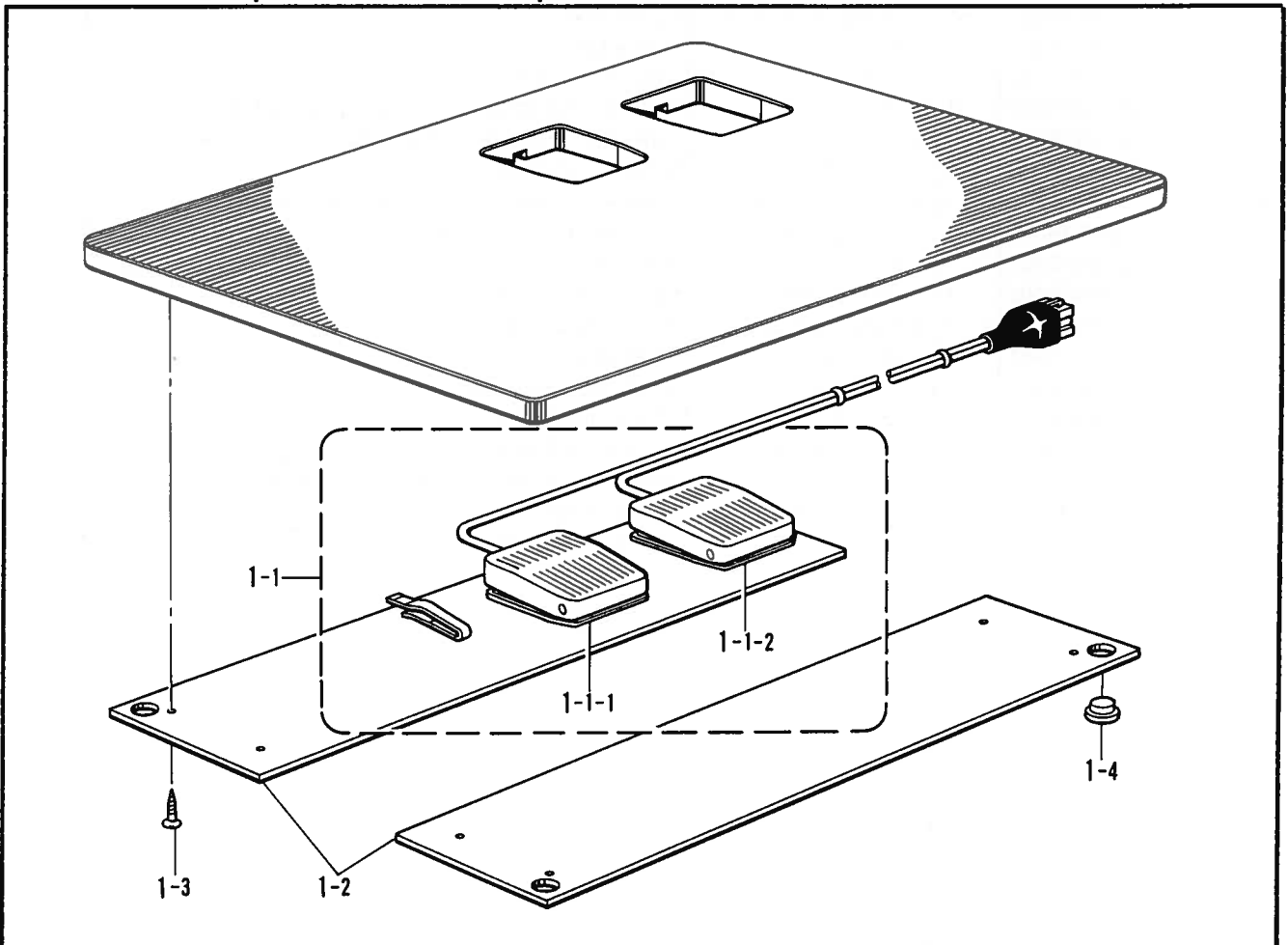

S. 糸ユルメ関係/Tension release mechanism/Spannungsverminderungsvorrichtung/
Mécanisme de la lâche de tension/Mecanismo relajador de tensión

REF.NO.	CODE	Q'TY	ヒンメイ	NAME OF PARTS	RMKS
1	S02658001	1	イトユルメレバー	TENSION RELEASE LEVER	
2	S11931001	1	イトユルメワイヤー	TENSION RELEASE WIRE	
3	110161004	2	ナツト4.76	NUT 4.76	
4	S11932001	1	ワイヤートリツケイタ	WIRE SET PLATE	
5	154607001	1	イトユルメワイヤーオサエD	TENSION RELEASE WIRE HOLDER (D)	
6	062670812	2	ナヘ"コ3.57-40X8	SCREW 357X8	
7	S11933001	1	イトユルメワイヤーオサエ	TENSION RELEASE WIRE HOLDER	
8	062671612	2	ナヘ"コ357-40X16	SCREW 357X16	
9	S03670001	1	イトユルメモト"シハ"ネ	SPRING	
10	340400001	1	ユニタイハ"ント"	BEAD BAND	
11	S00480000	1	コート"ホルタ"#5	CORD HOLDER 5N	
12	S07467001	1	チューブ"ササエ	TUBE SUPPORT	
13	018400822	1	アナホル"ルト4X8	BOLT 4X8	
14	025040232	1	ヒラサ"カ"ネチユウ4	PLAIN WASHER 4	

T. 踏板関係/Foot switch pedal mechanism/Fußbetätigung/
Mécanisme de la pédale/Mecanismo del pedal

REF.NO.	CODE	Q'TY	ヒンメイ	NAME OF PARTS	RMKS
1	S12222009	1	フットスイッチイタシクミ	FOOT SWITCH PLATE (L) ASSEMBLY	
1-1	S06550001	1	フットスイッチ2タ"ンクミ	FOOT SWITCH 2-STAGE ASSEMBLY	
1-1-1	S06551101	1	2タ"ンスイッチクミ	2-STAGE SWITCH ASSEMBLY	
1-1-2	S06552000	1	1タ"ンスイッチ	1-STAGE SWITCH	
1-2	S01824000	2	スイッチウケ	SWITCH SUPPORT	
1-3	034311302	10	+ サラモクネシ"3.1X13	SCREW 3.1X13	
1-4	159150009	4	カマシ"クメクラセン	OIL CAP	

U1. 空圧関係 / Air pressure mechanism / Luftdruck /
 Mécanisme de la pression d'air / Mecanismo de la presión de aire

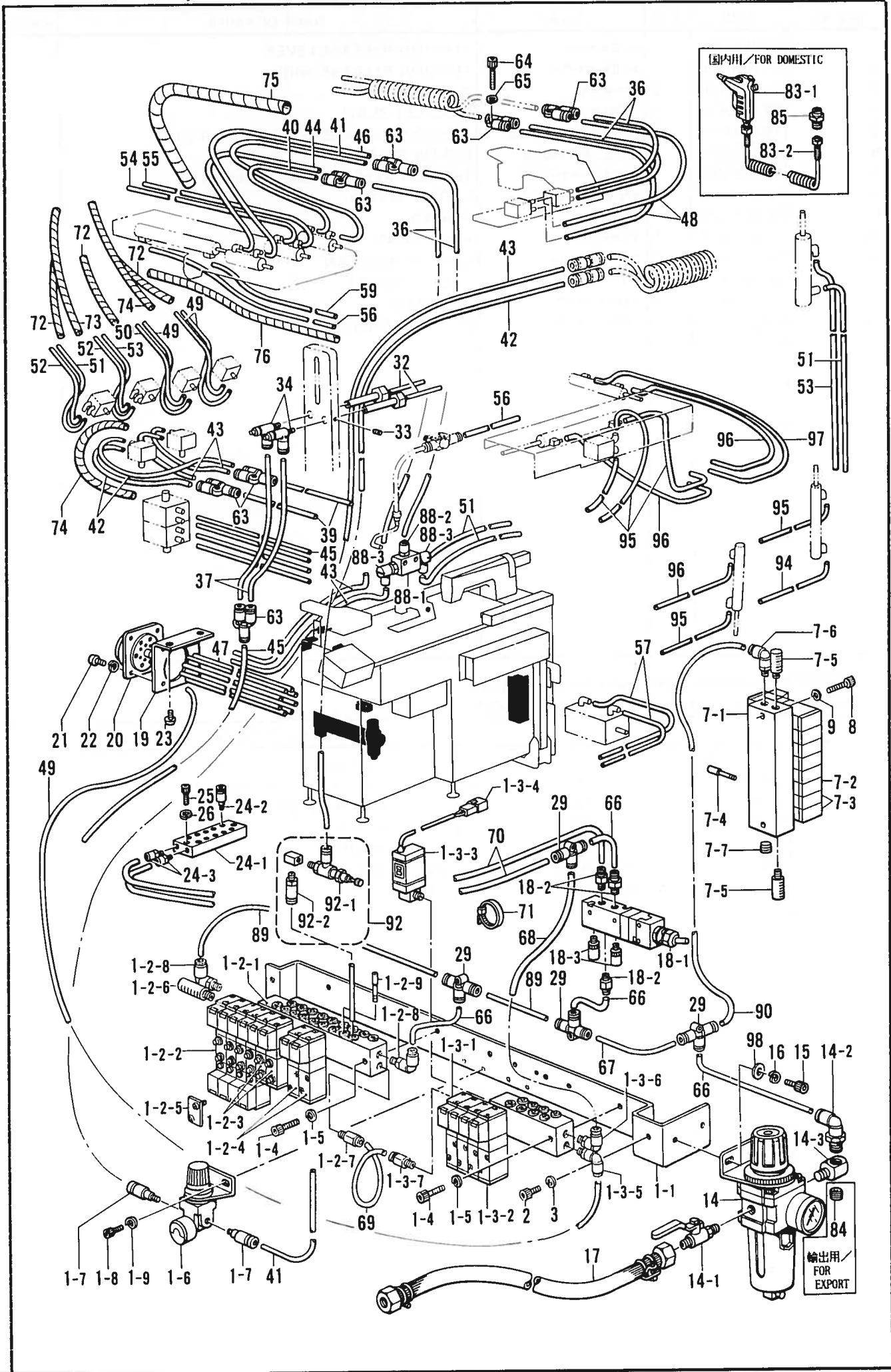

U1. 空圧関係/Air pressure mechanism/Luftdruck/
Mécanisme de la pression d'air/Mecanismo de la presión de aire

REF NO.	CODE	Q'TY	ヒンメイ	NAME OF PARTS	RMKS
1	S29166001	1	ハ"ルブ"クミ94	VALVE ASSEMBLY 94	
1-1	S12155101	1	ハ"ルブ"トリツケイタ	VALVE SET PLATE	
1-2	S17730001	1	ハ"ルブ"9ヒタ"リクミ	VALVE 9 LEFT ASSEMBLY	
1-2-1	S19067000	1	マニホルト"9	MANIHOLD 9	
1-2-2	S12158000	4	ハ"ルブ"VZ3243-N	VALVE VZ3243-N	
1-2-3	S12160000	2	ハ"ルブ"VZ3143-N	VALVE VZ3143-N	
1-2-4	S12161000	2	ハ"ルブ"VZ3143	VALVE VZ3143	
1-2-5	S12159000	1	メクラフタクミ	BLIND PLATE ASSEMBLY	
1-2-6	140682001	1	サイレンサー	SILENCER	
1-2-7	S01522000	1	ハーフユニオン	HALF UNION	
1-2-8	S01542000	2	エルボ"ユニオン61	ELBOW UNION 61	
1-2-9	S04897000	1	メクラセン	BLIND CAP	
1-3	S24939000	1	ハ"ルブ"4クミ	VALVE 4 ASSEMBLY	
1-3-1	S24940000	1	マニホルト"4	MANIHOLD 4	
1-3-2	S12161000	4	ハ"ルブ"VZ3143	VALVE VZ3143	
1-3-3	S12164000	1	アツリヨクスイッチ	PRESSURE SWITCH	
1-3-4	152509000	1	ナイロンコネクタE	NYLON CONNECTOR (E)	
1-3-5	S04909000	1	エルボ"ユニオン	ELBOW UNION	
1-3-6	S01542000	1	エルボ"ユニオン61	ELBOW UNION 61	
1-3-7	S01522000	1	ハーフユニオン	HALF UNION	
1-4	018503022	4	アナボ"ルト5X30	BOLT 5X30	
1-5	028050242	4	ハ"ネサ"カ"ネ2-5	SPRING WASHER 2-5	
1-6	S12165000	1	レキ"ユレーター	REGULATOR	
1-7	S04905000	2	ハーフユニオン	HALF UNION	
1-8	018400832	2	アナボ"ルト4X8	BOLT 4X8	
1-9	028040242	2	ハ"ネサ"カ"ネ2-4	SPRING WASHER 2-4	
2	018060822	2	アナボ"ルト6X8	BOLT 6X8	
3	028060242	2	ハ"ネサ"カ"ネ2-6	SPRING WASHER 2-6	
7	*	1	ハ"ルブ"8クミ	VALVE 8 ASSEMBLY	
7-1	S19526000	1	マニホルト"8	MANIHOLD 8	
7-2	S12160000	6	ハ"ルブ"VZ3143-N	VALVE VZ3143-N	
7-3	S12161000	2	ハ"ルブ"VZ3143	VALVE VZ3143	
7-4	S04897000	1	メクラセン	BLIND CAP	
7-5	140682001	2	サイレンサー	SILENCER	
7-6	S01542000	1	エルボ"ユニオン61	ELBOW UNION 61	
7-7	153274001	1	1/8トメセン	CAP 1/8	
8	018503022	2	アナボ"ルト5X30	BOLT 5X30	
9	028050242	2	ハ"ネサ"カ"ネ2-5	SPRING WASHER 2-5	
14	S12166000	1	フィルターレキ"ユレータークミ	FILTER REGULATOR ASSEMBLY	
14-1	S09231000	1	ボ"ールハ"ルブ"1/4	BALL VALVE 1/4	
14-2	S04896000	1	エルボ"ユニオン	ELBOW UNION	
14-3	153252000	1	PTチース"	PT-JOINT	
15	018061022	2	アナボ"ルト6X10	BOLT 6X10	
16	028060242	2	ハ"ネサ"カ"ネ2-6	SPRING WASHER 2-6	
17	149796001	1	ゴムホースカナグ"ツキ	AIR TUBE WITH CONNECTOR	
18	S12168000	1	メカニカルハ"ルブ"クミ	MECHANICAL VALVE ASSEMBLY	
18-1	S12169000	1	メカニカルハ"ルブ"	MECHANICAL VALVE	
18-2	S01522000	3	ハーフユニオン	HALF UNION	
18-3	S12170000	2	サイレンサ	SILENCER	
19	S12171001	1	カクヘキイター-1	BULKHEAD PLATE	
20	S12172000	1	マルチコネクタS	MULTI CONNECTOR (S)	
21	062400812	4	ナヘ"コ4X8	SCREW 4X8	
22	028040242	4	ハ"ネサ"カ"ネ2-4	SPRING WASHER 2-4	
23	062680812	2	ナヘ"コ437-40X8	SCREW 437X8	
24	S12167000	1	マニホルト"12クミ	MANIFOLD 12 ASSEMBLY	
24-1	S12173000	1	マニホルト"	MANIFOLD	
24-2	S04905000	12	ハーフユニオン	HALF UNION	
24-3	S12174000	2	ホースニツプル6M5	HOSE NIPPLE 6M5	
25	018401622	2	アナボ"ルト4X16	BOLT 4X16	
26	028040242	2	ハ"ネサ"カ"ネ2-4	SPRING WASHER 2-4	
29	S12175000	4	チース"φ6	T-JOINT φ6	
32	S12176000	2	エアブ"ロー	AIR BLOWER	

U1. 空圧関係 / Air pressure mechanism / Luftdruck /
 Mécanisme de la pression d'air / Mecanismo de la presión de aire

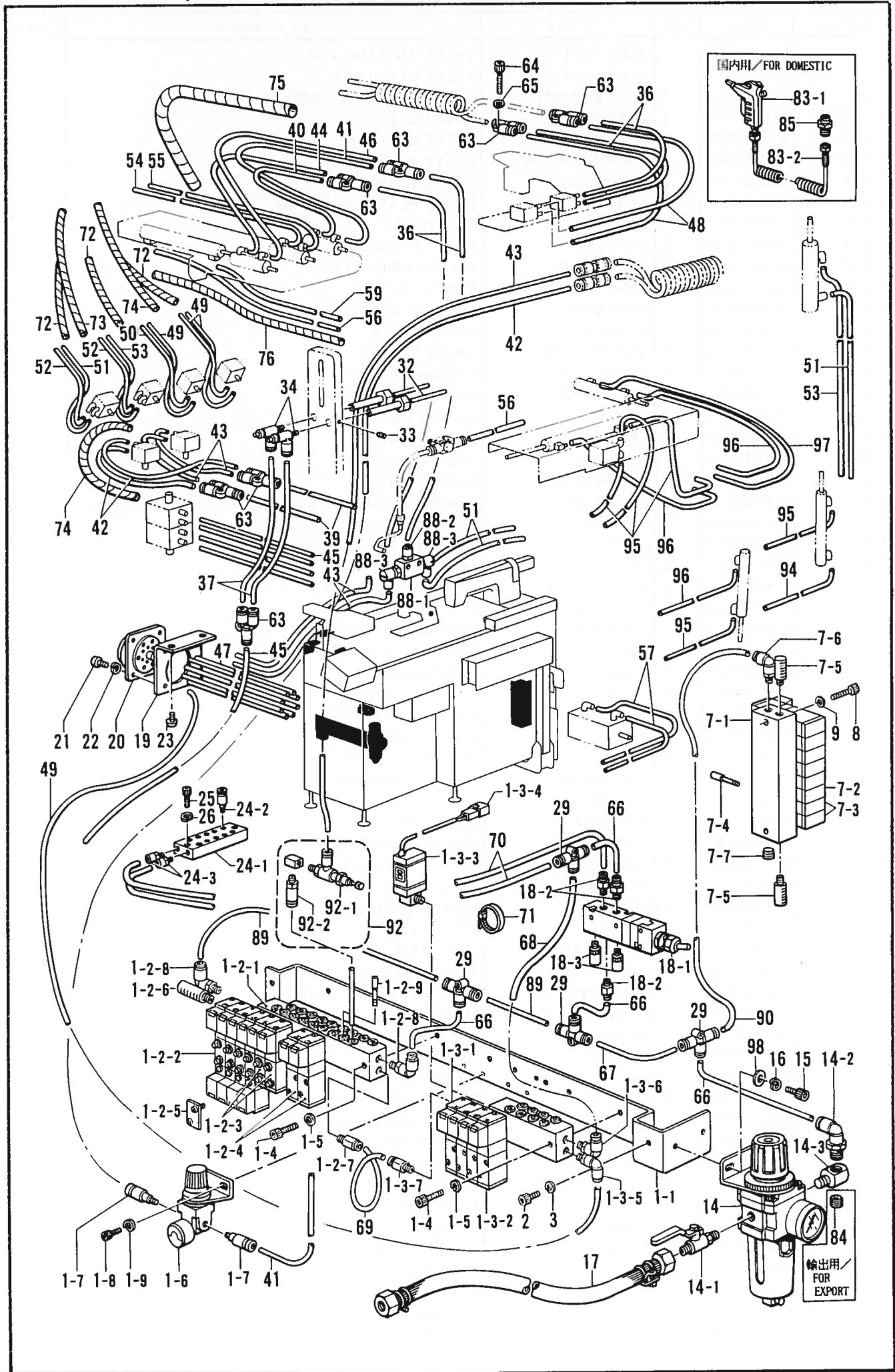

U1. 空圧関係 / Air pressure mechanism / Luftdruck /
Mécanisme de la pression d'air / Mecanismo de la presión de aire

REF.NO.	CODE	Q'TY	ヒンメイ	NAME OF PARTS	RMKS
33	014400522	2	アナクボ"ミ4X5	SET SCREW 4X5	
34	S14328000	2	シボ"リハ"ン	THROTTLE VALVE	
36	S12178000	4	エア-ホ-ス4X2.5-2	AIR TUBE 4X2.5-2 (L=130)	
37	S12179000	2	エア-ホ-ス4X2.5-3	AIR TUBE 4X2.5-3 (L=190)	
39	S12181000	2	エア-ホ-ス4X2.5-5	AIR TUBE 4X2.5-5 (L=290)	
40	S12182000	1	エア-ホ-ス4X2.5-6	AIR TUBE 4X2.5-6 (L=340)	
41	S12183000	2	エア-ホ-ス4X2.5-7	AIR TUBE 4X2.5-7 (L=430)	
42	S12184000	3	エア-ホ-ス4X2.5-8	AIR TUBE 4X2.5-8 (L=480)	
43	S12185000	5	エア-ホ-ス4X2.5-9	AIR TUBE 4X2.5-9 (L=510)	
44	S12186000	1	エア-ホ-ス4X2.5-10	AIR TUBE 4X2.5-10 (L=520)	
45	S12187000	5	エア-ホ-ス4X2.5-11	AIR TUBE 4X2.5-11 (L=570)	
46	S12188000	1	エア-ホ-ス4X2.5-12	AIR TUBE 4X2.5-12 (L=600)	
47	S12189000	8	エア-ホ-ス4X2.5-13	AIR TUBE 4X2.5-13 (L=630)	
48	S12190000	2	エア-ホ-ス4X2.5-14	AIR TUBE 4X2.5-14 (L=310)	
49	S12191000	4	エア-ホ-ス4X2.5-15	AIR TUBE 4X2.5-15 (L=770)	
50	S12192000	1	エア-ホ-ス4X2.5-16	AIR TUBE 4X2.5-16 (L=780)	
51	S12193000	4	エア-ホ-ス4X2.5-17	AIR TUBE 4X2.5-17 (L=890)	
52	S12194000	2	エア-ホ-ス4X2.5-18	AIR TUBE 4X2.5-18 (L=920)	
53	S12195000	2	エア-ホ-ス4X2.5-19	AIR TUBE 4X2.5-19 (L=930)	
54	S12196000	1	エア-ホ-ス4X2.5-20	AIR TUBE 4X2.5-20 (L=1060)	
55	S12197000	1	エア-ホ-ス4X2.5-21	AIR TUBE 4X2.5-21 (L=1090)	
56	S12198000	2	エア-ホ-ス4X2.5-22	AIR TUBE 4X2.5-22 (L=1300)	
57	*	2	エア-ホ-ス4X2.5-15	AIR TUBE 4X2.5-15 (L=770)	
59	S12201000	1	エア-ホ-ス4X2.5-25	AIR TUBE 4X2.5-25 (L=1700)	
63	S12104000	7	ユニオンワイ4	UNION-Y 4	
64	018403022	3	アナボ"ルト4X30	BOLT 4X30	
65	028040242	3	ハ"ネサ"ガ"ネ2-4	SPRING WASHER 2-4	
66	S12206000	4	エア-ホ-ス6X4-1	AIR TUBE 6X4-1 (L=50)	
67	S12207000	1	エア-ホ-ス6X4-2	AIR TUBE 6X4-2 (L=170)	
68	S12208000	1	エア-ホ-ス6X4-3	AIR TUBE 6X4-3 (L=200)	
69	S12209000	1	エア-ホ-ス6X4-4	AIR TUBE 6X4-4 (L=320)	
70	S12210000	2	エア-ホ-ス6X4-5	AIR TUBE 6X4-5 (L=400)	
71	S04159000	25	バンド"1M	BAND 1M	
72	S12211000	3	スパ"イラル130S	SPIRAL 130S	
73	S12212000	1	スパ"イラル290S	SPIRAL 290S	
74	S12213000	2	スパ"イラル430S	SPIRAL 430S	
75	S12214000	1	スパ"イラル640L	SPIRAL 640L	
76	S12215000	1	スパ"イラル640S	SPIRAL 640S	
83	S06857000	1	エアガ"ンクミ	-----	
83-1	S06858000	1	エアガ"ン	-----	
83-2	S06859000	1	カールホ-ス	-----	
84	*	1	-----	1/4PT CAP	
85	S04891000	1	チユウガンニツプ"ル1/4	-----	
88	S15561000	2	クイックエキゾ"ーストクミ	QUICK EXHAUST ASSEMBLY	
88-1	S15562000	2	クイックエキゾ"ースト	QUICE EXHAUST	
88-2	S11433000	2	ホ-スニツプ"ル4M5	HOSE NIPPLE 4M5	
88-3	S12150000	4	ホ-スエルボ"M-5HL-4	TUBE ELBOW (M-5HL-4)	
89	S19585000	2	エア-ホ-ス6X4-6	AIR TUBE 6X4-6 (L=230)	
90	S24953000	1	エア-ホ-ス6X4-8	AIR TUBE 6X4-8(L=1400)	
92	S19971000	1	ケ"ンアツハ"ンM5-04クミ	PRESSER REDUCING VALVE M5-04 ASSEMBLY	
92-1	S19972000	1	ケ"ンアツハ"ンM5-04	PRESSURE REDUCING VALVE M5-04	
92-2	S29240000	1	メスユニオン4-M5	UNION 4-M5	
94	*	1	エア-ホ-ス4X2.5-15	AIR TUBE 4X2.5-15 (L=770)	
95	*	5	エア-ホ-ス4X2.5-17	AIR TUBE 4X2.5-17 (L=890)	
96	*	3	エア-ホ-ス4X2.5-20	AIR TUBE 4X2.5-20 (L=1060)	
97	*	1	エア-ホ-ス4X2.5-21	AIR TUBE 4X2.5-21 (L=1090)	
98	025060232	2	ヒラサ"ガ"ネチユウ6	PLAIN WASHER 6	

U2. 空圧関係 / Air pressure mechanism / Luftdruck /
 Mécanisme de la pression d'air / Mecanismo de la presión de aire

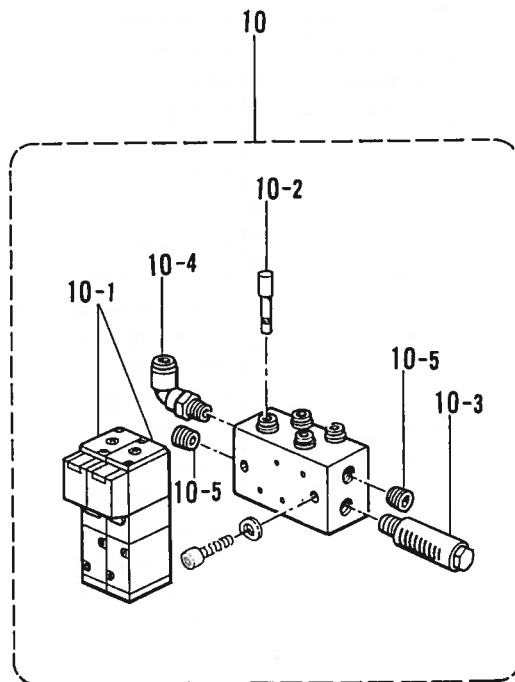
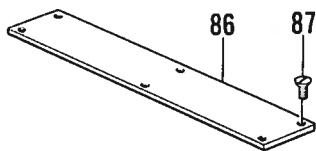
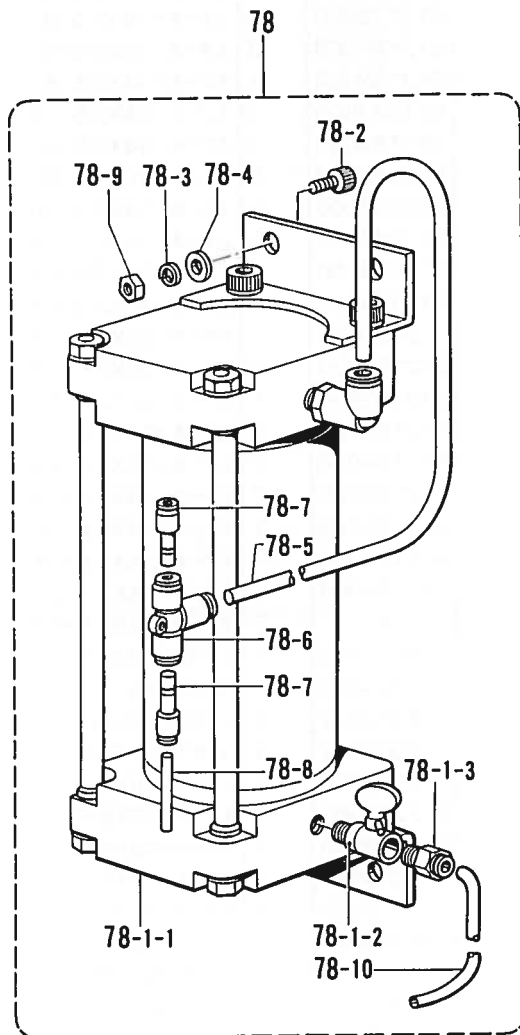
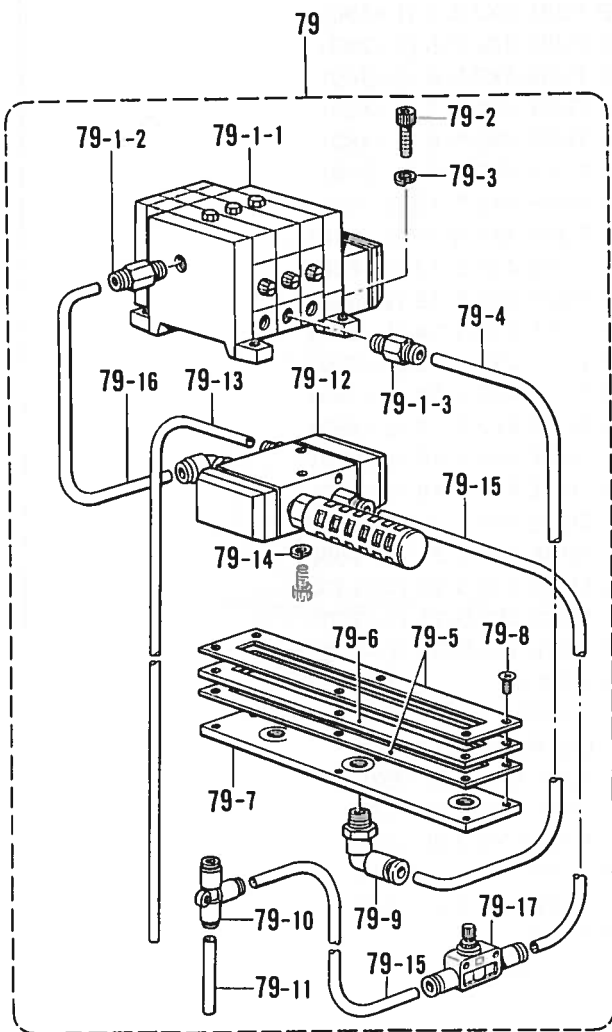

U2. 空圧関係 / Air pressure mechanism / Luftdruck /
 Mécanisme de la pression d'air / Mecanismo de la presión de aire

REF.NO.	CODE	Q'TY	品名	NAME OF PARTS	RMKS
10	*	1	ハ"ルブ"2クミ	-----	
10-1	S12161000	2	ハ"ルブ"VZ3143	-----	
10-2	S04897000	1	メクラセン	-----	
10-3	140682001	1	サイレンサー	-----	
10-4	S01542000	1	エルボ"ユニオン61	-----	
10-5	153274001	2	1/8トメセン	-----	
78	*	1	-----	TANK UNIT	
78-1	S11953000	1	-----	AIR TANK ASSEMBLY	
78-1-1	S11952000	1	-----	AIR TANK	
78-1-2	149438000	1	-----	SPEED CONTROLLER (B)	
78-1-3	S01522000	1	-----	HALF UNION	
78-2	018081622	2	-----	BOLT 8X16	
78-3	028080242	2	-----	SPRING WASHER 2-8	
78-4	025080232	2	-----	PLAIN WASHER 8	
78-5	S11956000	1	-----	AIR TUBE 10X75 (L=1700)	
78-6	S11957000	1	-----	T-JOINT 010	
78-7	S11958000	2	-----	REDUCER	
78-8	S12206000	1	-----	AIR TUBE 6X4-1 (L=50)	
78-9	021080302	2	-----	NUT 8	
78-10	S12207000	1	-----	AIR TUBE 6X4-2 (L=170)	
79	*	1	ハ"キユームソウチクミ	VACUUM EQUIPMENT ASSEMBLY	
79-1	S12497000	1	シクウエシ"エクタークミ	VACUUM EJECTOR ASSEMBLY	
79-1-1	S12498000	1	シクウエシ"エクター	VACUUM EJECTOR	
79-1-2	S01208000	1	ハーフユニオン	HALF UNION	
79-1-3	S01522000	3	ハーフユニオン	HALF UNION	
79-2	018501622	2	アナホ"ルト5X16	BOLT 5X16	
79-3	028050242	2	ハ"ネサ"カ"ネ2-5	SPRING WASHER 2-5	
79-4	S12209000	3	エア"ホース6X4-4	AIR TUBE 6X4-4 (L=320)	
79-5	S12499000	2	ハ"キユームカ"スケツト	VACUUM GASKET	
79-6	S12500001	1	ハ"キユームウエ	VACUUM UPPER	
79-7	S12501001	1	ハ"キユームシタ	VACUUM LOWER	
79-8	004401414	6	+サラコ4X14	SCREW 4X14	
79-9	S04896000	3	エルボ"ユニオン	ELBOW UNION	
79-10	S12175000	1	チース"φ6	T-JOINT φ6	
79-11	S12206000	1	エア"ホース6X4-1	AIR TUBE 6X4-1 (L=50)	
79-12	S12502000	1	エアオペ"ハ"ルブ"クミ	AIR OPERATION VALVE ASSEMBLY	
79-13	S12191000	1	エア"ホース4X2.5-15	AIR TUBE 4X2.5-15 (L=770)	
79-14	028030242	2	ハ"ネサ"カ"ネ2-3	SPRING WASHER 2-3	
79-15	S12207000	2	エア"ホース6X4-2	AIR TUBE 6X4-2 (L=170)	
79-16	S12210000	2	エア"ホース6X4-5	AIR TUBE 6X4-5 (L=400)	
79-17	S12509000	1	シホ"リハ"ン6	THROTTLE VALVE6	
86	*	1	ハ"キユームウラフタ	-----	
87	*	6	サラネシ"4.37	-----	

V1. 電装品関係 / Power supply equipment mechanism / Stromversorgung / Mécanisme de l'équipement en alimentation électrique / Mecanismo del equipo de alimentación de corriente

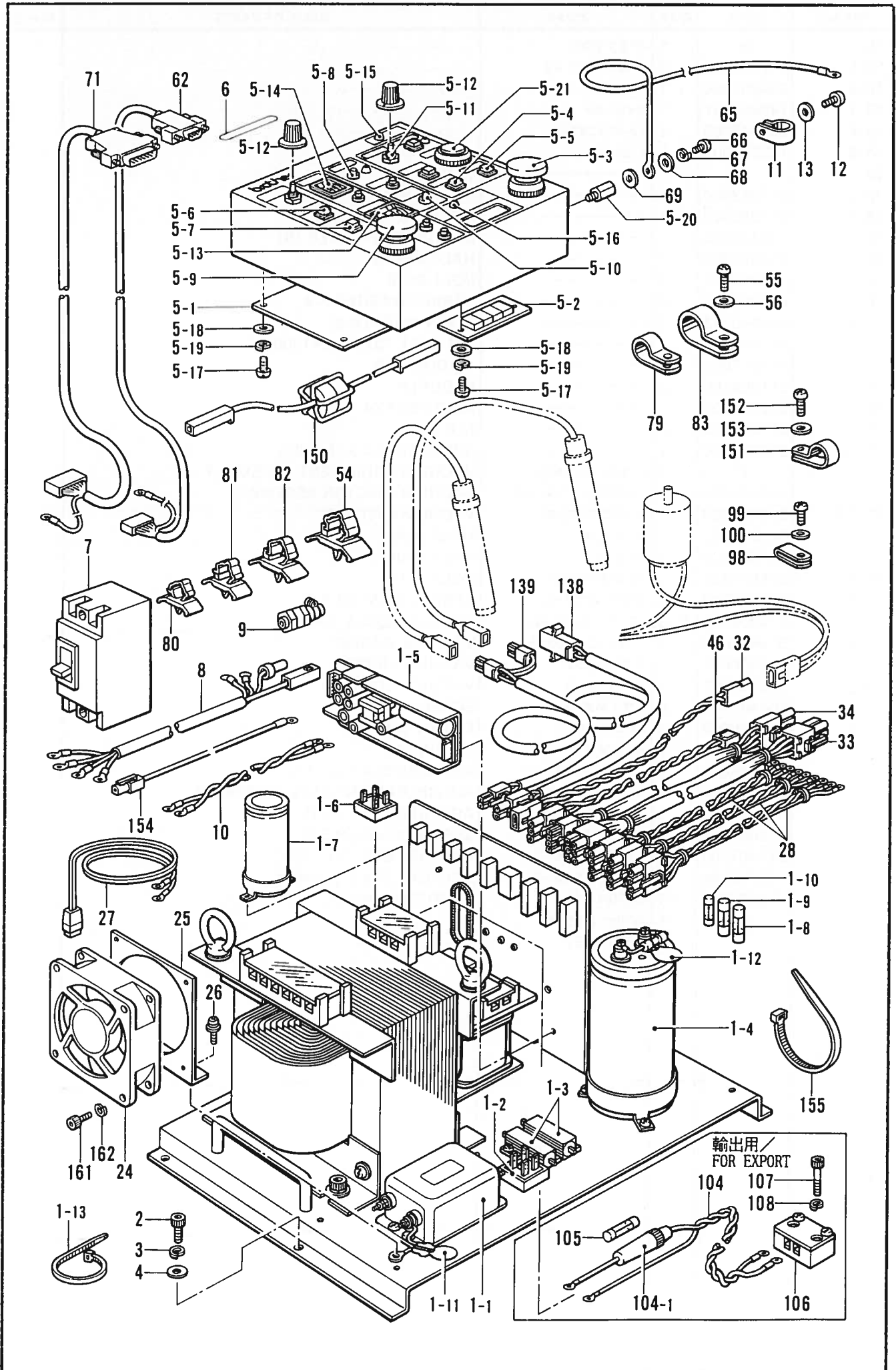

V1. 電装品関係/Power supply equipment mechanism/Stromversorgung/Mécanisme de l'équipement en alimentation électrique/Mecanismo del equipo de alimentación de corriente

REF.NO.	CODE	Q'TY	ヒンメイ	NAME OF PARTS	RMKS
1	S20019001	1	デ"ンケ"ンソウチクミ	POWER SUPPLY EQUIPMENT ASSEMBLY	
1-1	S11811000	1	ノイズ"フィルタ	NOISE FILTER (A)	
1-2	S20049000	1	SIBRS25VB60	SIBRS25VB60	
1-3	S20053000	2	メタルクラット"テイコウ	METAL-CLAD RESISTANCE	
1-4	S20054000	1	デ"ンC400B332	ELECTRON 400B332	
1-5	S17029000	1	AVR	AVR	
1-6	S10315000	1	SIBRS15VB10	SIBRS15VB10	
1-7	S16558000	1	デ"ンC63B472	ELECTRON C63B472	
1-8	S04173000	1	ヒューズ"20A	FUSE 20A	
1-9	S20038000	1	ヒューズ"3A	FUSE 3A	
1-10	152565000	1	ヒューズ"B	FUSE (B)	
1-11	S20051000	1	ノイズ"Cクミ	NOISE (C) ASSEMBLY	
1-12	S20029000	1	ブ"リーダ"テイコウクミ	BLEEDER RESISTANCE ASSEMBLY	
1-13	S04557000	5	パ"ンタイPLTIM	BAND PLTIM	
2	018400822	4	アナボ"ルト4X8	BOLT 4X8	
3	028040242	4	ハ"ネサ"ガ"ネ2-4	SPRING WASHER 2-4	
4	025040232	4	ヒラサ"ガ"ネチユウ4	PLAIN WASHER 4	
5	S30105009	1	ソウサBOXクミ	OPERATION BOX ASSEMBLY	
5-1	S11826000	1	ヒョウシ"キハ"ンクミ	INDICATE CIRCUIT BOARD ASSEMBLY	
5-2	S11827000	1	LEDキハ"ンクミ	LIGHT EMITTING DIODE ASSEMBLY	
5-3	S11756100	1	スイッチ1M	SWITCH 1M	
5-4	S11755000	1	スイッチ2M	SWITCH 2M	
5-5	S11754000	2	スイッチ3M	SWITCH 3M	
5-6	S11753000	2	スイッチ4M	SWITCH 4M	
5-7	S11752000	1	スイッチ5A	SWITCH 5A	
5-8	S11749000	5	スイッチ6M	SWITCH 6M	
5-9	S11750000	1	スイッチ7M	SWITCH 7M	
5-10	S11751000	1	スイッチ8M	SWITCH 8M	
5-11	S11748000	2	ロータリスイッチ	ROTARY SWITCH	
5-12	157875000	2	ロータリスイッチツマミ	ROTARY SWITCH KNOB	
5-13	S11757000	1	デ"ジ"SW3	DIGITAL SWITCH (3)	
5-14	S04993000	1	デ"ジ"タルスイッチB	DIGITAL SWITCH (B)	
5-15	152430000	3	LED-B	LIGHT EMITTING DIODE (B)	
5-16	152429000	1	LED-A	LIGHT EMITTING DIODE (A)	
5-17	002300803	6	+ナヘ"コ3X8	SCREW 3X8	
5-18	025030133	6	ヒラサ"ガ"ネシヨウ3	PLAIN WASHER 3	
5-19	028030243	6	ハ"ネサ"ガ"ネ2-3	SPRING WASHER 2-3	
5-20	S11761000	1	アースタンシ	EARTH TERMINAL	
5-21	S11706000	1	スイッチ9M	SWITCH 9M	
8	S23868000	1	デ"ンケ"ンハーネスA	POWER SUPPLY HARNESS (A)	
9	152510000	1	コード"ブツシユ	CORD BUSH	
10	S25585000	1	デ"ンケ"ンハーネスB	POWER SUPPLY HARNESS (B)	
11	554482000	1	コード"ホルダ"12	CORD HOLDER (12N)	
12	062400806	1	ナヘ"コ4X8	SCREW M4X8	
13	025040233	1	ヒラサ"ガ"ネチユウ4	PLAIN WASHER 4	
24	S10335001	1	クー"リング"ファン	COOLING FAN	
25	S11803001	1	FANトリツケイタ	FAN FIXING PLATE	
26	S21083001	3	+ナヘ"コハ"ネヒラ4X10	WASHER SCREW 4X10	
27	S25208000	1	ファンコード"クミ	FAN CORD ASSEMBLY	
28	S25582000	3	サーボ"デ"ンケ"ンハーネス	SERVO POWER SUPPLY HARNESS	
32	S11702000	1	イトマキハーネス	BOBBIN WINDER HARNESS	
33	S25206000	1	メインハ"ワーハーネス	MIN POWER HARNESS	
34	S25207000	1	オリキハ"ワーハーネス	FOLDING POWER HARNESS	
46	S25583000	1	FDDデ"ンケ"ンハーネス	FDD POWER SUPPLY HARNESS	
54	S09141000	10	コード"クランプ"16L	CORD CLAMP 16-L	
55	062400806	10	ナヘ"コ4X8	SCREW M4X8	
56	025040233	10	ヒラサ"ガ"ネチユウ4	PLAIN WASHER 4	
62	S11716000	1	オリキソウサホ"ツクスハーネス	FOLDING MACHINE OPERATION BOX HARNESS	
65	S25205000	1	アースセン2000S	EARTH WIRE 2000S	
66	062300506	1	ナヘ"コ3X5	SCREW 3X5	
67	028030243	1	ハ"ネサ"ガ"ネ2-3	SPRING WASHER 2-3	
68	025030133	1	ヒラサ"ガ"ネシヨウ3	PLAIN WASHER 3	

V1. 電装品関係/Power supply equipment mechanism/Stromversorgung/Mécanisme de l'équipement en alimentation électrique/Mecanismo del equipo de alimentación de corriente

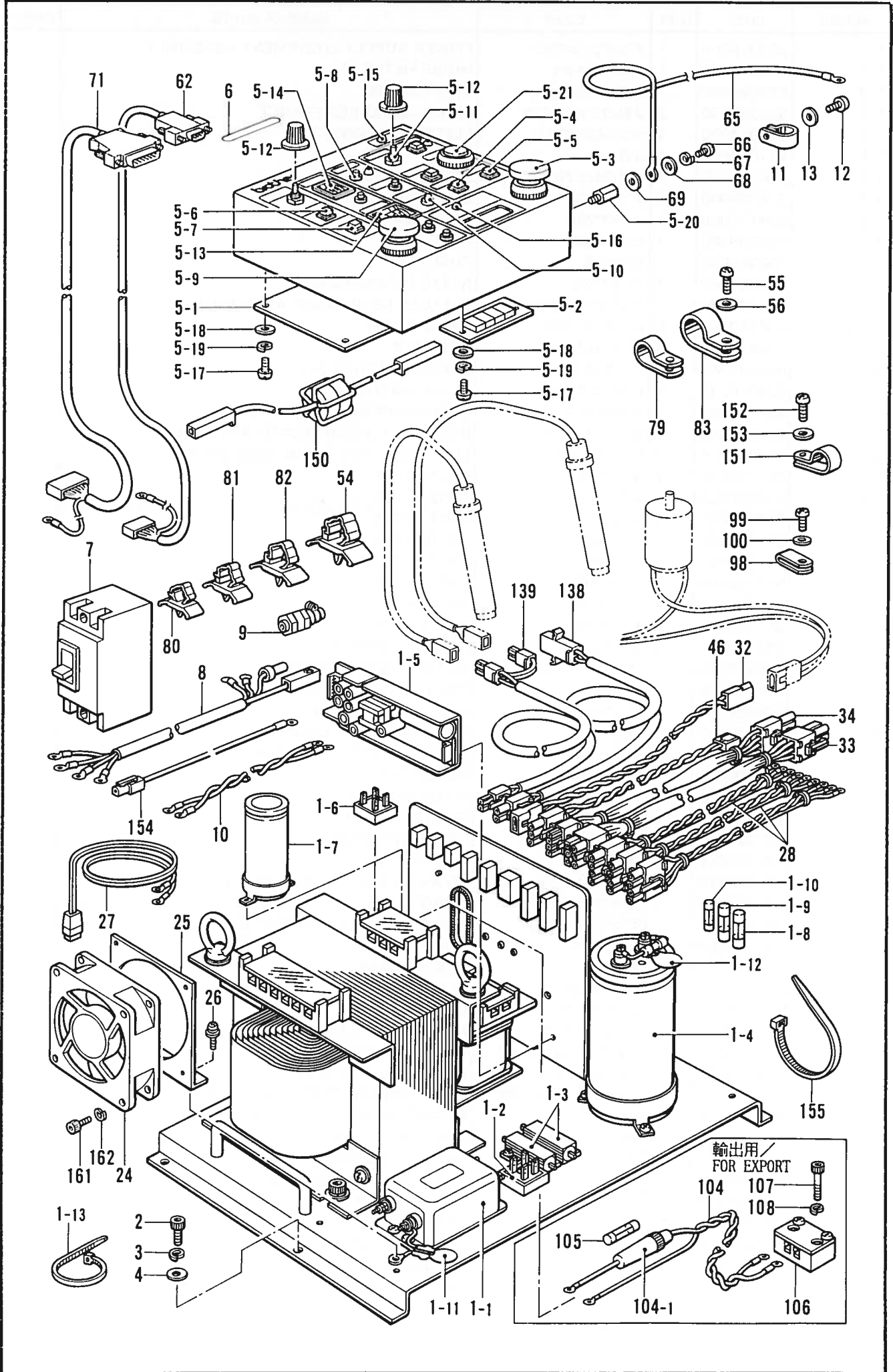

V1. 電装品関係/Power supply equipment mechanism/Stromversorgung/Mécanisme de l'équipement en alimentation électrique/Mecanismo del equipo de alimentación de corriente

REF NO.	CODE	Q'TY	ヒンメイ	NAME OF PARTS	RMKS
69	025030233	1	ヒラサ"ガ"ネチユウ3	PLAIN WASHER 3	
71	S11717000	1	ソウサBOXハーネス	OPERATION BOX HARNESS	
79	525907000	2	コード"ホルダ"#9	CORD HOLDER (9N)	
80	S11848000	5	コード"クランプ"#7	CORD CLAMP 7N	
81	150349001	2	コード"クランプ"10	CORD CLAMP 10-L	
82	150357001	6	コード"クランプ"13	CORD CLAMP (13-L)	
83	S11817000	4	クランプ"NK-18N	CLAMP NK-18N	
98	552908000	2	コード"ホルダ"#14	CORD HOLDER (14N)	
99	062400806	2	ナヘ"コ4X8	SCREW M4X8	
100	025040233	2	ヒラサ"ガ"ネチユウ4	PLAIN WASHER 4	
104	*	1	-----	TERMINAL HARNESS	
104-1	S11709000	1	-----	FUSE HOLDER	
105	*	1	-----	FUSE 0.5A	
106	*	1	-----	TERMINAL BLOCK 2P	
107	*	2	-----	BOLT 4X12	
108	*	2	-----	SPRING WASHER 2-4	
138	S23328000	1	テモトライトハーネス	HAND LIGHT HARNESS	
139	S23329000	1	マーカハーネスN	MARKER HARNESS (N)	
150	S11728000	1	アースインダ"クタ1	EARTH INDUCTOR (1)	
151	S11816000	2	クランプ"NK-2N	CLAMP NK-2N	
152	062400806	2	ナヘ"コ4X8	SCREW M4X8	
153	025040233	2	ヒラサ"ガ"ネチユウ4	PLAIN WASHER 4	
154	S23869200	1	アースインダ"クタ2S	EARTH INDUCTOR (2S)	
155	S06143000	1	バンド"PLT4S	BAND PLT4S	
161	018300822	4	アナホ"ルト3X8	BOLT 3X8	
162	028030242	4	ハ"ネサ"ガ"ネ2-3	SPRING WASHER 2-3	
<BAS-752>					
6	S30107009	1	752ソウサBOXシール	-----	
<BAS-754>					
6	S30109009	1	754ソウサBOXシール	-----	
<BAS-750L>					
6	S30171009	1	-----	750L BOX SEAL	
<BAS-750KL>					
6	S30173009	1	-----	750KL BOX SEAL	
<200V, 220V>					
7	S10287000	1	ブ"レーカ10A	BREAFER (10A)	
<380V, 415V>					
7	S08106000	1	-----	BREAKER (5A)	

V2. 電装品関係/Power supply equipment mechanism/Stromversorgung/Mécanisme de l'équipement en alimentation électrique/Mecanismo del equipo de alimentación de corriente

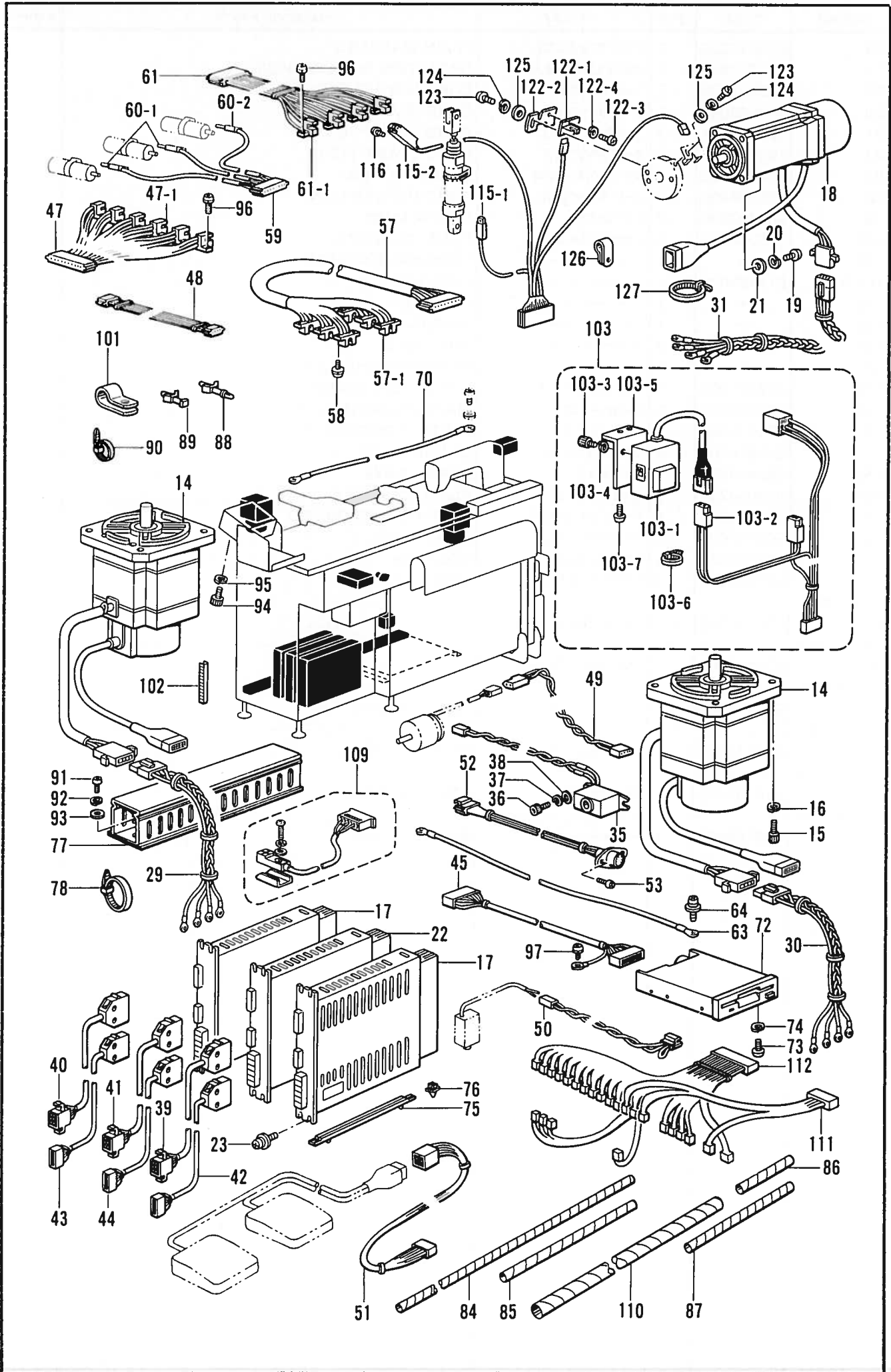

V2. 電装品関係/Power supply equipment mechanism/Stromversorgung/Mécanisme de l'équipement en alimentation électrique/Mecanismo del equipo de alimentación de corriente

REF.NO.	CODE	Q'TY	ヒンメイ	NAME OF PARTS	RMKS
14	S20045000	2	クト"ウモータXYクミ	DRIVING MOTOR (XY) ASSEMBLY	
15	018082022	8	アナホ"ルト8X20	BOLT 8X20	
16	028080242	8	ハ"ネサ"カ"ネ2-8	SPRING WASHER 2-8	
17	S20047000	2	サーボ"アンプ"XY	X-Y SERVO AMP	
18	S20551000	1	マシンモータ330Wクミ	MACHINE MOTOR (330W) ASSEMBLY	
19	018501622	4	アナホ"ルト5X16	BOLT 5X16	
20	028050242	4	ハ"ネサ"カ"ネ2-5	SPRING WASHER 2-5	
21	025050132	4	ヒラサ"カ"ネシヨウ5	PLAIN WASHER 5	
22	S20552000	1	サーボ"アンプ"-Z330W	SERVO AMP Z330W	
23	602394001	12	+ナヘ"ネジ"4X16SWツキ	SCREW 4X16 WITH SWITCH	
29	S25209000	1	モータハ"ワ"ハーネスX	MOTOR POWER HARNESS (X)	
30	S25210000	1	モータハ"ワ"ハーネスY	MOTOR POWER HARNESS (Y)	
31	S25575000	1	モータハ"ワ"ハーネスZ	MOTOR POWER HARNESS (Z)	
35	S11693000	1	ブ"サ"ークミ	BUZZER ASSEMBLY	
36	018400822	2	アナホ"ルト4X8	BOLT 4X8	
37	028040242	2	ハ"ネサ"カ"ネ2-4	SPRING WASHER 2-4	
38	025040232	2	ヒラサ"カ"ネチユウ4	PLAIN WASHER 4	
39	S25579100	1	エンコーダ"ハーネスX	ENCODER HARNESS (X)	
40	S25580100	1	エンコーダ"ハーネスY	ENCODER HARNESS (Y)	
41	S25581100	1	エンコーダ"ハーネスZ	ENCODER HARNESS (Z)	
42	S25576000	1	サーボ"ハーネスX	SERVO HARNESS (X)	
43	S25577000	1	サーボ"ハーネスY	SERVO HARNESS (Y)	
44	S25578000	1	サーボ"ハーネスZ	SERVO HARNESS (Z)	
45	S11694000	1	FDDハーネス	FDD HARNESS	
47	S11696100	1	フォトセンサクミ	PHOTO SENSOR ASSEMBLY	
47-1	S08119000	6	ホトセンサ-EE-SV3	PHOTO SENSOR EE-SV3	
48	S11697000	1	オリキハーネス	FOLDING MACHINE HARNESS	
49	S11698000	1	イトキリハーネス	THREAD TRIMMER HARNESS	
50	S11703000	1	エアSWハーネス	AIR SWITCH HARNESS	
51	S11700000	1	フットSWハーネス	-----	
52	S11701000	1	プログ"ラマハーネス	PROGRAMMER HARNESS	
53	062300505	2	ナヘ"コ3X5	SCREW 3X5	
57	S11715200	1	ジ"ク"ハ"ター"クミ	JIG PATTERN ASSEMBLY	
57-1	S05035000	6	フォトマイクロセンサ	PHOTO MICRO SENSOR	
58	215083001	12	+ナヘ"セット3X6D	WASHER SCREW 3X6D	
59	S11712000	1	シリンダ"センサクミ	CYLINDER SENSOR ASSEMBLY	
60-1	S12458000	2	シリンダ"センサ2	CYLINDER SENSOR-2	
60-2	S12459000	1	シリンダ"センサ3	CYLINDER SENSOR-3	
61	S11711000	1	クランプ"インセンサクミ	CLAMP-IN SENSOR ASSEMBLY	
61-1	S08119000	4	ホトセンサ-EE-SV3	PHOTO SENSOR EE-SV3	
63	S11731000	1	アースセン1300	EARTH WIRE 1300	
64	052400806	1	ナヘ"コハ"ネヒラ4X8	WASHER SCREW 4X8	
70	S11732000	1	アースセン1700S	EARTH WIRE 1700S	
72	S16661001	1	3.5フロツピ"ート"ドライブ"	3.5 INCH FLOPPY DRIVE	
73	062300805	4	ナヘ"コ3X8	SCREW 3X8	
74	028030243	4	ハ"ネサ"カ"ネ2-3	SPRING WASHER 2-3	
75	S11840000	6	ガ"イト"レール	GUIDE RAIL	
76	S11841000	6	キハ"ンコテイダ"イ	CIRCUIT BOARD FIXID STUD	
77	S11842000	1	ケーブ"ルダ"クト	CABLE DUCT	
78	149809000	3	タイラツツ"L	BEAD BAND (L)	
84	S12215000	2	スパイラル640S	SPIRAL 640S	
85	S12212000	1	スパイラル290S	SPIRAL 290S	
86	S11763000	2	スパイラル100S	SPIRAL 100S	
87	S11762000	1	スパイラル200S	SPIRAL (200S)	
88	S02915100	8	キハ"ンサホ"ート	CIRCUIT BOARD SUPPORT	
89	S11839000	14	キハ"ンスヘ"ーサ	CIRCUIT BOARD SPACER	
90	S04159000	10	ハ"ンド"1M	BAND 1M	
91	062401006	2	ナヘ"コ4X10	SCREW 4X10	
92	028040243	2	ハ"ネサ"カ"ネ2-4	SPRING WASHER 2-4	
93	025040233	2	ヒラサ"カ"ネチユウ4	PLAIN WASHER 4	
94	018400832	4	アナホ"ルト4X8	BOLT 4X8	
95	028040242	4	ハ"ネサ"カ"ネ2-4	SPRING WASHER 2-4	

V2. 電装品関係/Power supply equipment mechanism/Stromversorgung/Mécanisme de l'équipement en alimentation électrique/Mecanismo del equipo de alimentación de corriente

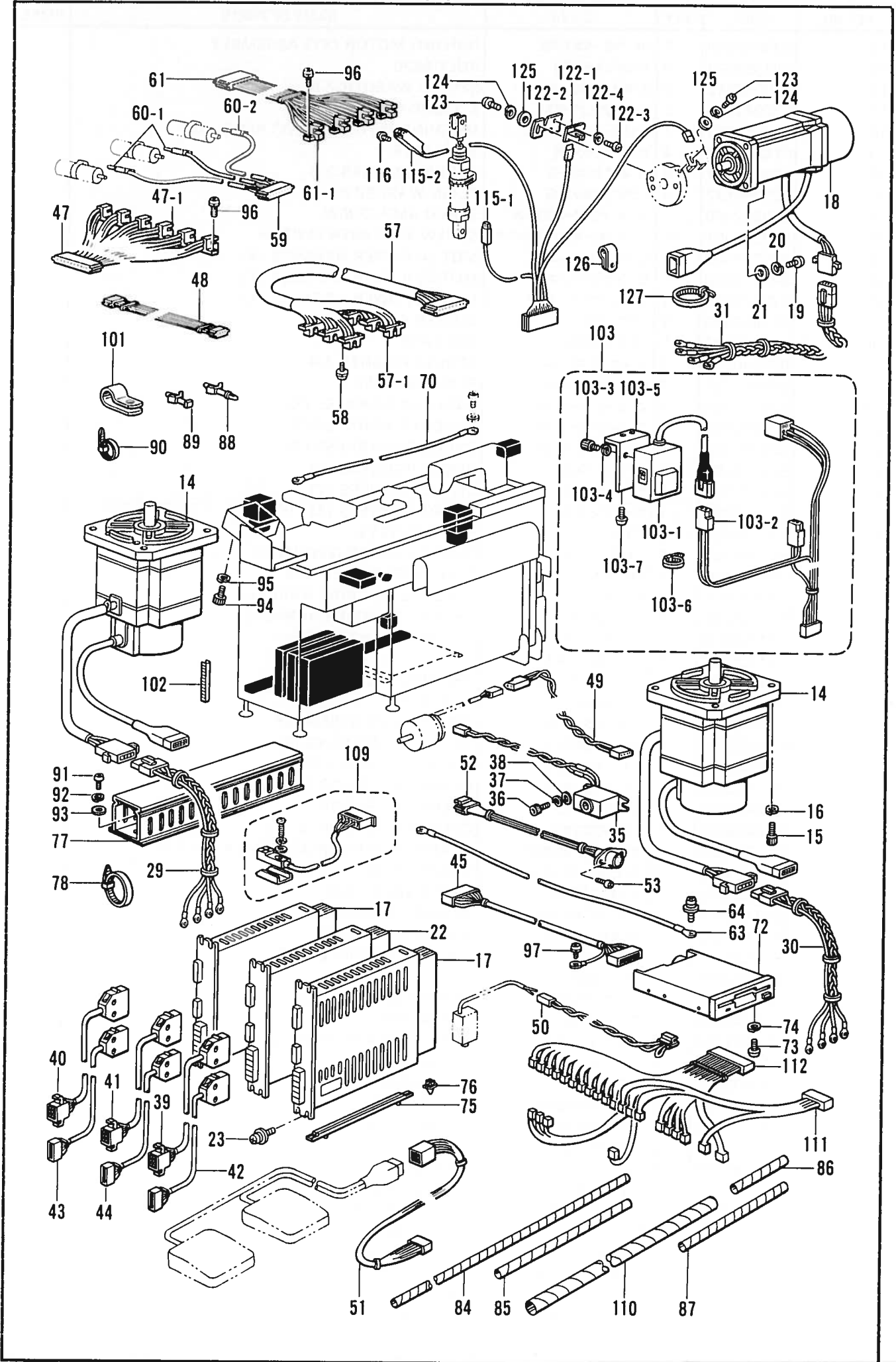

V2. 電装品関係/Power supply equipment mechanism/Stromversorgung/Mécanisme de l'équipement
en alimentación eléctrica/Mecanismo del equipo de alimentación de corriente

REF.NO.	CODE	Q'TY	ヒンメイ	NAME OF PARTS	RMKS
96	215083001	20	+ナヘ"セツト3X6D	WASHER SCREW 3X6D	
97	215083001	1	+ナヘ"セツト3X6D	WASHER SCREW 3X6D	
101	149547000	1	コート"オサエ	CORD HOLDER (4N)	
102	S12466000	1	ジ"サ"イフ"ツシユB	FREE BUSH (B)	
103	*	1	-----	HAND SWITCH ASSEMBLY	
103-1	S12565009	2	-----	HAND SWITCH ASSEMBLY (A)	
103-2	S12465000	1	-----	FOOT SWITCH HARNESS 2	
103-3	018400832	4	-----	BOLT 4X8	
103-4	028040242	4	-----	SPRING WASHER 2-4	
103-5	S11951001	1	-----	SWITCH SET PLATE	
103-6	S04159000	5	-----	BAND 1M	
103-7	062681012	2	-----	SCREW 437X10	
109	S25868100	1	オサエセンサN	SEWING CLAMP SENSOR (N)	
110	S12214000	1	スパイラル640L	SPIRAL 640L	
111	S19509000	1	オサエアシハーネスN	WORK CLAMP HARNESS (N)	
112	S19510000	1	ソレノイド"クト"ウハーネスN	SOLENOID DRIVING HARNESS (N)	
115	S11714400	1	マシンセンサクミ	MACHINE SENSOR ASSEMBLY	
115-1	S11830400	1	シリンダ"センサ1	CYLINDER SENSOR 1	
115-2	S11831300	1	アンプ"ユニットクミ	AMP UNIT ASSEMBLY	
116	062401012	1	ナヘ"コM4X10	SCREW M4X10	
122	S12463001	2	センサキハ"ンクミ1	SENSOR CIRCUIT BOARD ASSEMBLY-1	
122-1	S11828000	2	センサキハ"ンクミ	SENSOR CIRCUIT BOARD ASSEMBLY	
122-2	S12461001	2	センサフ"ラケット	SENSOR BRACKET	
122-3	062300612	4	ナヘ"コ3X6	SCREW 3X6	
122-4	028030242	4	ハ"ネサ"カ"ネ2-3	SPRING WASHER 2-3	
123	062300612	2	ナヘ"コ3X6	SCREW 3X6	
124	028030242	2	ハ"ネサ"カ"ネ2-3	SPRING WASHER 2-3	
125	025030132	2	ヒラサ"カ"ネシヨウ3	PLAIN WASHER 3	
126	S00480000	4	コート"ホルタ"#5	CORD HOLDER 5N	
127	149809000	1	タイラツフ"L	BEAD BAND (L)	

<BAS-752, 750L>

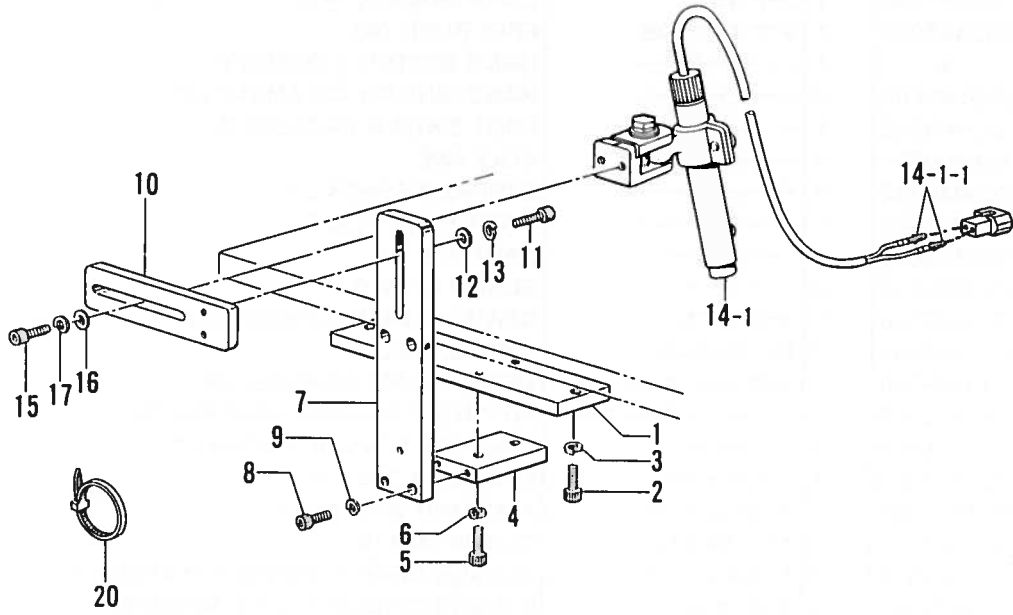

オプションパーツ/OPTION PARTS

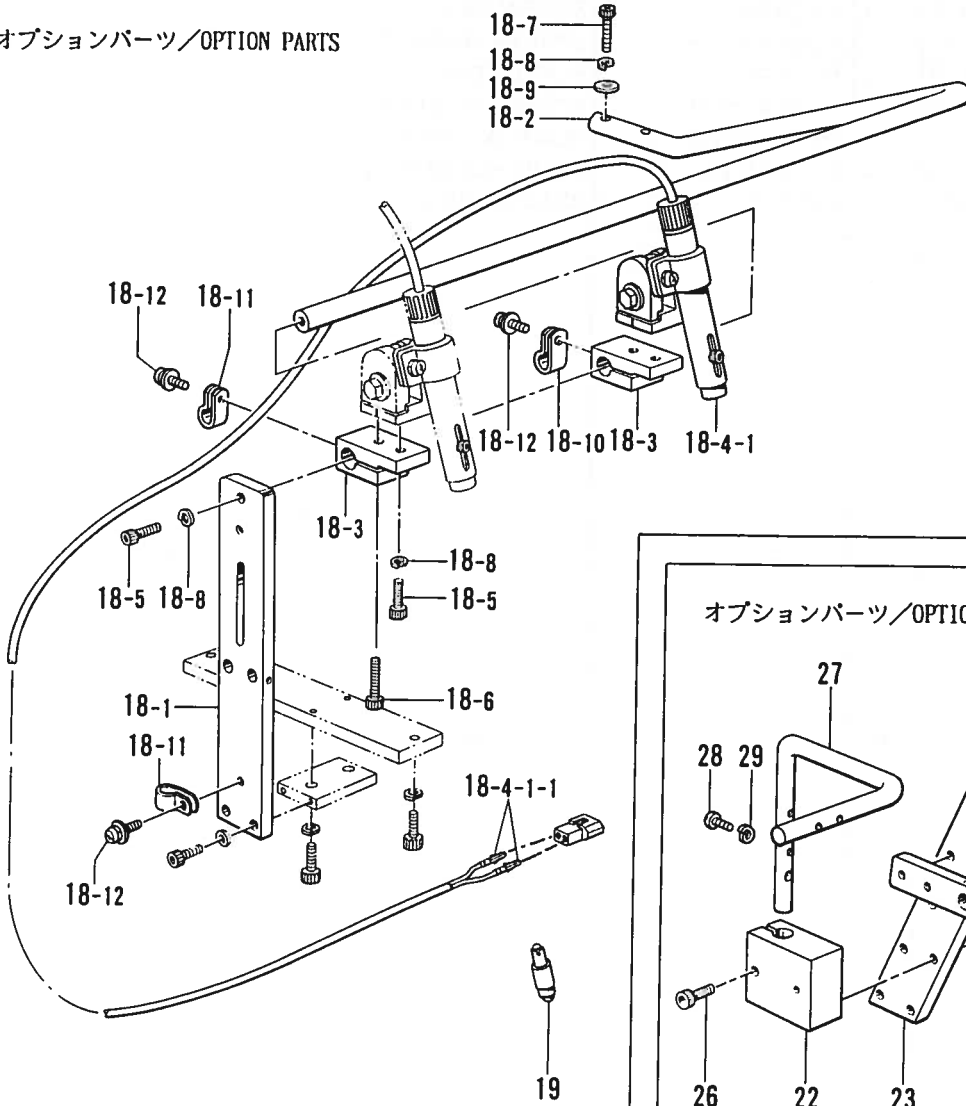

オプションパーツ/OPTION PARTS

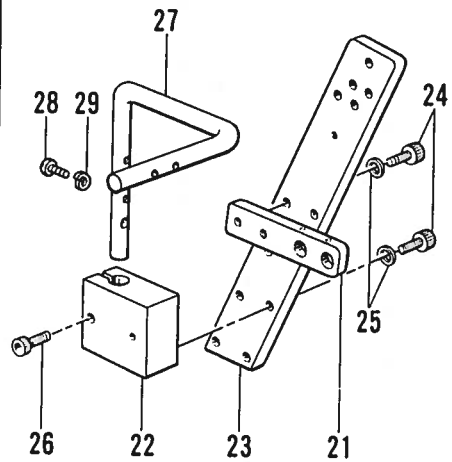

W1. マーカー関係/Marker mechanism/Markierungsvorrichtung/
Mécanisme du marqueur/Mecanismo del marcador

REF.NO.	CODE	Q'TY	ヒンメイ	NAME OF PARTS	RMKS
<BAS-752, 750L>					
1	S12216001	1	ト"タ"イスヘーサー	BASE SPACER	
2	018501622	2	アナボ"ルト5X16	BOLT 5X16	
3	028050242	2	ハ"ネサ"カ"ネ2-5	SPRING WASHER 2-5	
4	S12217001	1	ランプ"トリツケ"タイ	LAMP SET STUD	
5	018502022	2	アナボ"ルト5X20	BOLT 5X20	
6	028050242	2	ハ"ネサ"カ"ネ2-5	SPRING WASHER 2-5	
7	S15569001	1	ランプ"ト"タイ"ササエ	LAMP BASE SUPPORT	
8	018501622	2	アナボ"ルト5X16	BOLT 5X16	
9	028050242	2	ハ"ネサ"カ"ネ2-5	SPRING WASHER 2-5	
10	S12219001	1	ランプ"ト"タイ	LAMP BASE	
11	018502022	2	アナボ"ルト5X20	BOLT 5X20	
12	025050232	2	ヒラサ"カ"ネチユウ-5	PLAIN WASHER 5	
13	028050242	2	ハ"ネサ"カ"ネ2-5	SPRING WASHER 2-5	
14	S27937000	1	マーキング"ライト"クミT	MARKING LIGHT ASSEMBLY (T)	
14-1	S27938000	1	ライト"マーカ"ト	MARKING LIGHT (T)	
14-1-1	S08017000	2	オスビ"ン5006TL	PIN	
15	018502022	2	アナボ"ルト5X20	BOLT 5X20	
16	025050232	2	ヒラサ"カ"ネチユウ-5	PLAIN WASHER 5	
17	028050242	2	ハ"ネサ"カ"ネ2-5	SPRING WASHER 2-5	
20	S04159000	5	ハ"ント"1M	BAND 1M	
<オプションパーツ / OPTION PARTS>					
18	S30514001	1	タ"フル"マーカークミN	DOUBLE MARKER ASSEMBLY (N)	
18-1	S17710001	1	ランプ"ト"タイ"ササエL	LAMP BASE SUPPORT (L)	
18-2	S17711101	1	ランプ"トリツケ"	LAMP SETTER	
18-3	S17709001	2	マーカ"ート"リツケ	MARKER SETTER	
18-4	S27937000	1	マーキング"ライト"クミT	MARKING LIGHT ASSEMBLY (T)	
18-4-1	S27938000	1	ライト"マーカ"ト	MARKING LIGHT (T)	
18-4-1-1	S08017000	2	オスビ"ン5006TL	PIN	
18-5	018502022	3	アナボ"ルト5X20	BOLT 5X20	
18-6	018503022	2	アナボ"ルト5X30	BOLT 5X30	
18-7	018502522	2	アナボ"ルト5X25	BOLT 5X25	
18-8	028050242	5	ハ"ネサ"カ"ネ2-5	SPRING WASHER 2-5	
18-9	S20246001	2	ヒラサ"カ"ネ"タ"イ5	PLAIN WASHER 5	
18-10	149547000	1	コ"ート"オサエ	CORD HOLDER (4N)	
18-11	525664000	2	コ"ート"ホル"タ"#6	CORD HOLDER (6N)	
18-12	052400806	3	ナ"ヘ"コ"ハ"ネ"ヒラ4X8	WASHER SCREW 4X8	
19	S08137000	1	ランプ"5W	LAMP 5W	
21	S23399001	1	ランプ"ト"タイ"ササエL	LAMP BASE SUPPORT (L)	
22	S23400001	1	ハ"ネル"ササエ	PANEL SUPPORT	
23	S23401001	1	ブ"ロー"ササエ	BLOW SUPPORT	
24	018501622	5	アナボ"ルト5X16	BOLT 5X16	
25	028050242	5	ハ"ネサ"カ"ネ2-5	SPRING WASHER 2-5	
26	018502022	1	アナボ"ルト5X20	BOLT 5X20	
27	S23402001	1	ハ"ネル"ササエ"ホ"ウ	PANEL SUPPORT STUD	
28	062400616	1	ナ"ヘ"コ"M4X6	SCREW M4X6	
29	028040243	1	ハ"ネサ"カ"ネ2-4	SPRING WASHER 2-4	

W2. マーカー関係 / Marker mechanism / Markierungsvorrichtung /
 Mécanisme du marqueur / Mecanismo del marcador

<BAS-754, 750KL>

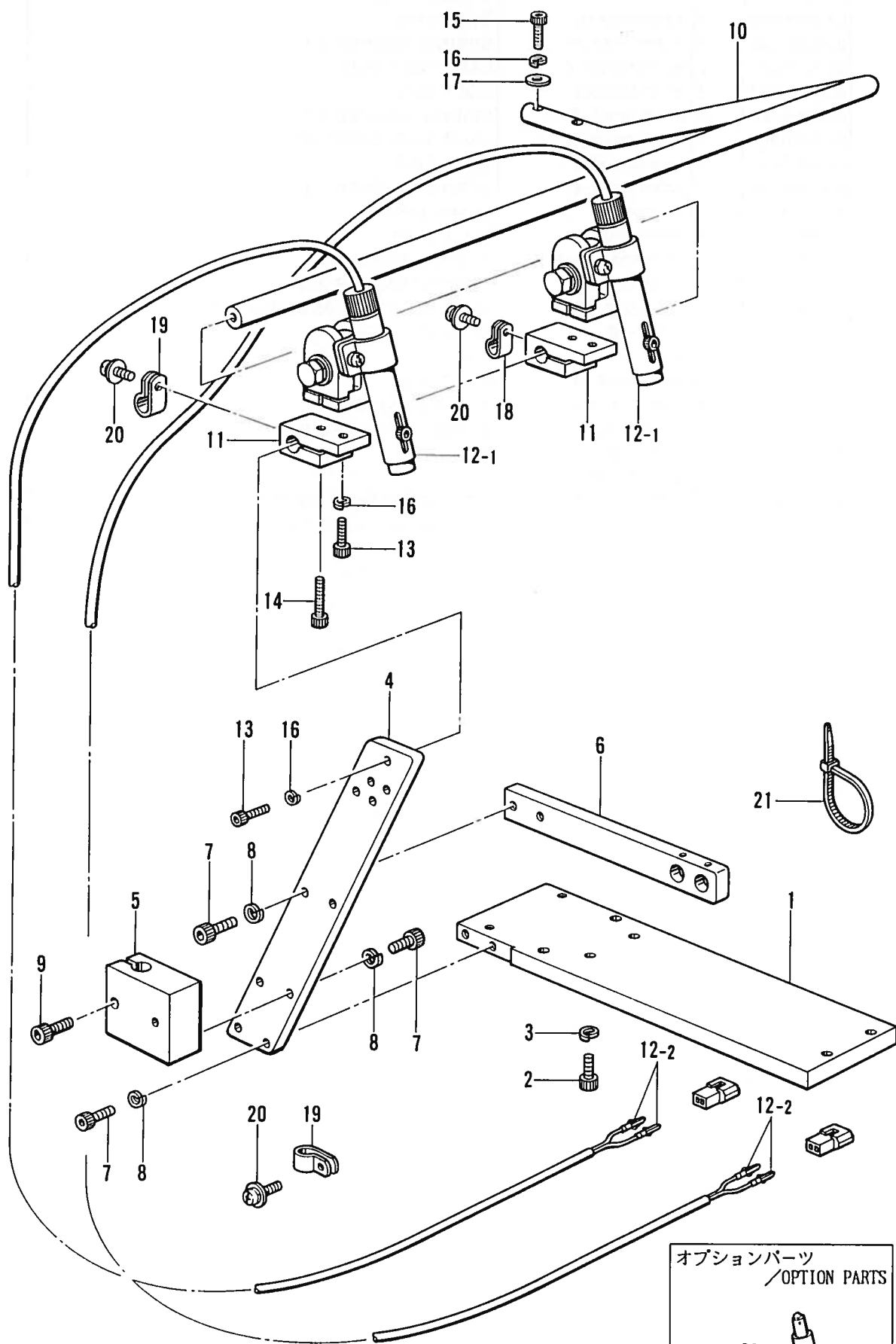

オプションパーツ
 / OPTION PARTS

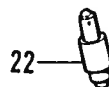

W2. マーカー関係 / Marker mechanism / Markierungsvorrichtung /
 Mécanisme du marqueur / Mecanismo del marcador

REF.NO.	CODE	Q'TY	ヒンメイ	NAME OF PARTS	RMKS
<BAS-754, 750KL>					
1	S25073001	1	ト"タ"イスヘーサー	BASE SPACER	
2	018501622	2	アナホ"ルト5X16	BOLT 5X16	
3	028050242	2	ハ"ネサ"カ"ネ2-5	SPRING WASHER 2-5	
4	S23399001	1	ランプト"タ"イササエL	LAMP BASE SUPPORT (L)	
5	S23400001	1	ハ"ネルササエ	PANEL SUPPORT	
6	S25072001	1	ブ"ローササエL	BLOW SUPPORT	
7	018501622	7	アナホ"ルト5X16	BOLT 5X16	
8	028050242	7	ハ"ネサ"カ"ネ2-5	SPRING WASHER 2-5	
9	018502022	1	アナホ"ルト5X20	BOLT 5X20	
10	S25074001	1	ランプトリツケ	LAMP SETTER	
11	S17709001	2	マーカートリツケ	MARKER SETTER	
12	S27937000	2	マーキング"ライトクミT	MARKING LIGHT ASSEMBLY (T)	
12-1	S27938000	2	ライトマーカT	MARKING LIGHT (T)	
12-1-1	S08017000	4	オスピン5006TL	PIN	
13	018502022	3	アナホ"ルト5X20	BOLT 5X20	
14	018503022	2	アナホ"ルト5X30	BOLT 5X30	
15	018502522	2	アナホ"ルト5X25	BOLT 5X25	
16	028050242	5	ハ"ネサ"カ"ネ2-5	SPRING WASHER 2-5	
17	S20246001	2	ヒラサ"カ"ネタ"イ5	PLAIN WASHER 5	
18	149547000	1	コード"オサエ	CORD HOLDER (4N)	
19	525664000	2	コード"ホルタ"#6	CORD HOLDER (6N)	
20	052400806	3	ナヘ"コハ"ネヒラ4X8	WASHER SCREW 4X8	
21	S04159000	5	バンド"1M	BAND 1M	
<オプションパーツ / OPTION PARTS>					
22	S08137000	1	ランプ"5W	LAMP 5W	

X. プリント基板関係 / Printed circuit boards mechanism / Leiterplatten /
Circuits imprimés / Tableros de circuitos impresos

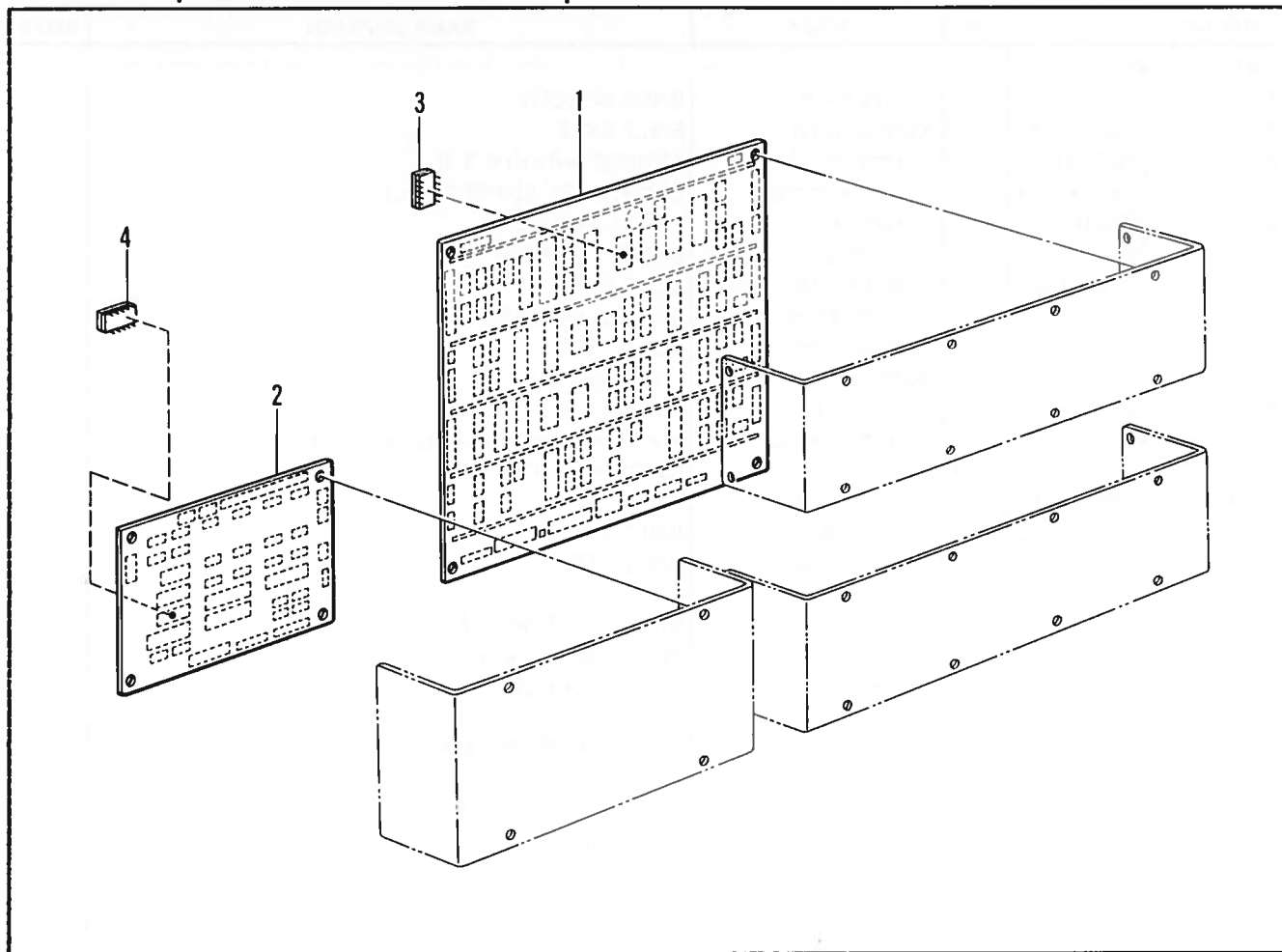

Y. モーター関係 / Motor mechanism / Motor /
Mécanisme du moteur / Mecanismo del motor

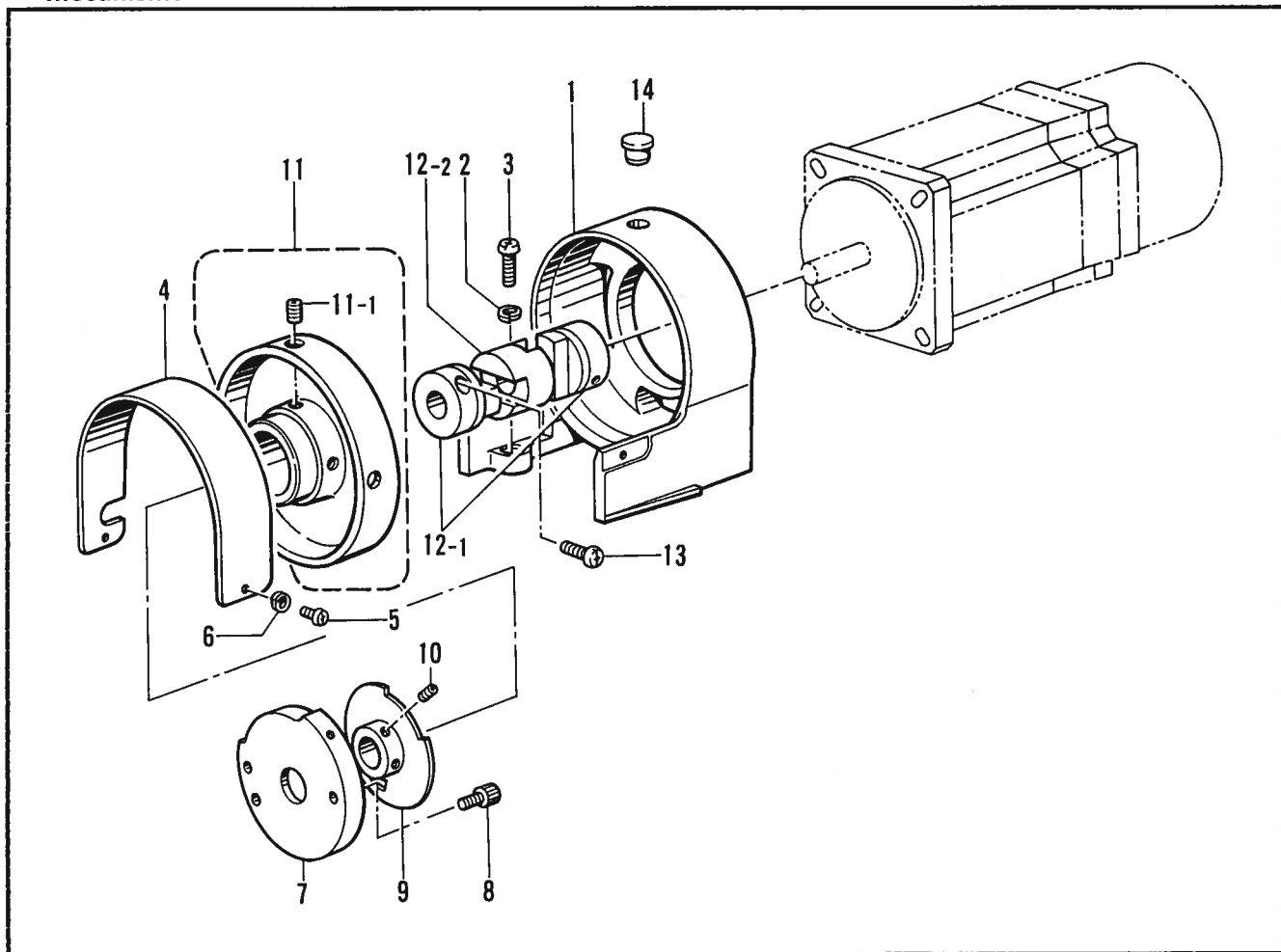

X. プリント基板関係/Printed circuit boards mechanism/Leiterplatten/
Circuits imprimés/Tableros de circuitos impresos

REF.NO.	CODE	Q'TY	ヒンメイ	NAME OF PARTS	RMKS
1	S23871001	1	メインキハ"ンクミJ	MAIN CIRCUIT BOARD ASSEMBLY	
2	S21186101	1	オリキキハ"ンクミL	FOLDING MACHINE CIRCUIT BOARD ASSY(L)	
3	S29992000	1	PROM752-1	PROM752-1	
4	*	1	PROM750-2	PROM750-2	
4	*	1	PROM750-2ニット	PROM750-2 (KNIT)	

Y. モータ関係/Motor mechanism/Motor/
Mécanisme du moteur/Mecanismo del motor

REF.NO.	CODE	Q'TY	ヒンメイ	NAME OF PARTS	RMKS
1	S29883009	1	DDモータブ"ラケット	DD-MOTOR BRACKET	
2	028060243	2	ハ"ネサ"ガ"ネ2-6	SPRING WASHER 2-6	
3	062061606	2	ナヘ"コ6X16	SCREW 6X16	
4	S11935009	1	プー"リカハ"	PULLEY COVER	
5	062300612	2	ナヘ"コ3X6	SCREW 3X6	
6	028030242	2	ハ"ネサ"ガ"ネ2-3	SPRING WASHER 2-3	
7	S11936101	1	センサトメカラ	SENSOR STOP COLLAR	
8	018401022	2	アナホ"ルト4X10	BOLT 4X10	
9	S11937001	1	センサト"ク"クミ	SENSOR DOG ASSEMBLY	
10	014400422	2	アナトメネジ"4X4クホ"ミ	SET SCREW 4X4	
11	S29881009	1	プー"リクミ	PULLEY ASSEMBLY	
11-1	014500522	2	アナトメネジ"5クホ"ミ	SET SCREW 5	
12	S24964000	1	カツプ"リンク"クミ	COUPLING ASSEMBLY	
12-1	S24965000	2	カツプ"リンク"A	COUPLING (A)	
12-2	S24966000	1	カツプ"リンク"B	COUPLING (B)	
13	062401212	2	ナヘ"コ4X12	SCREW 4X12	
14	104450109	1	メクラセン	OIL CAP	

Z1. 動力台関係/Power table/Motorgestell/
 Mécanisme du plateau de la machine/Mecanismo de la mesa de la máquina

<BAS-752, 750L>

国内用/ FOR DOMESTIC
 102 — 103

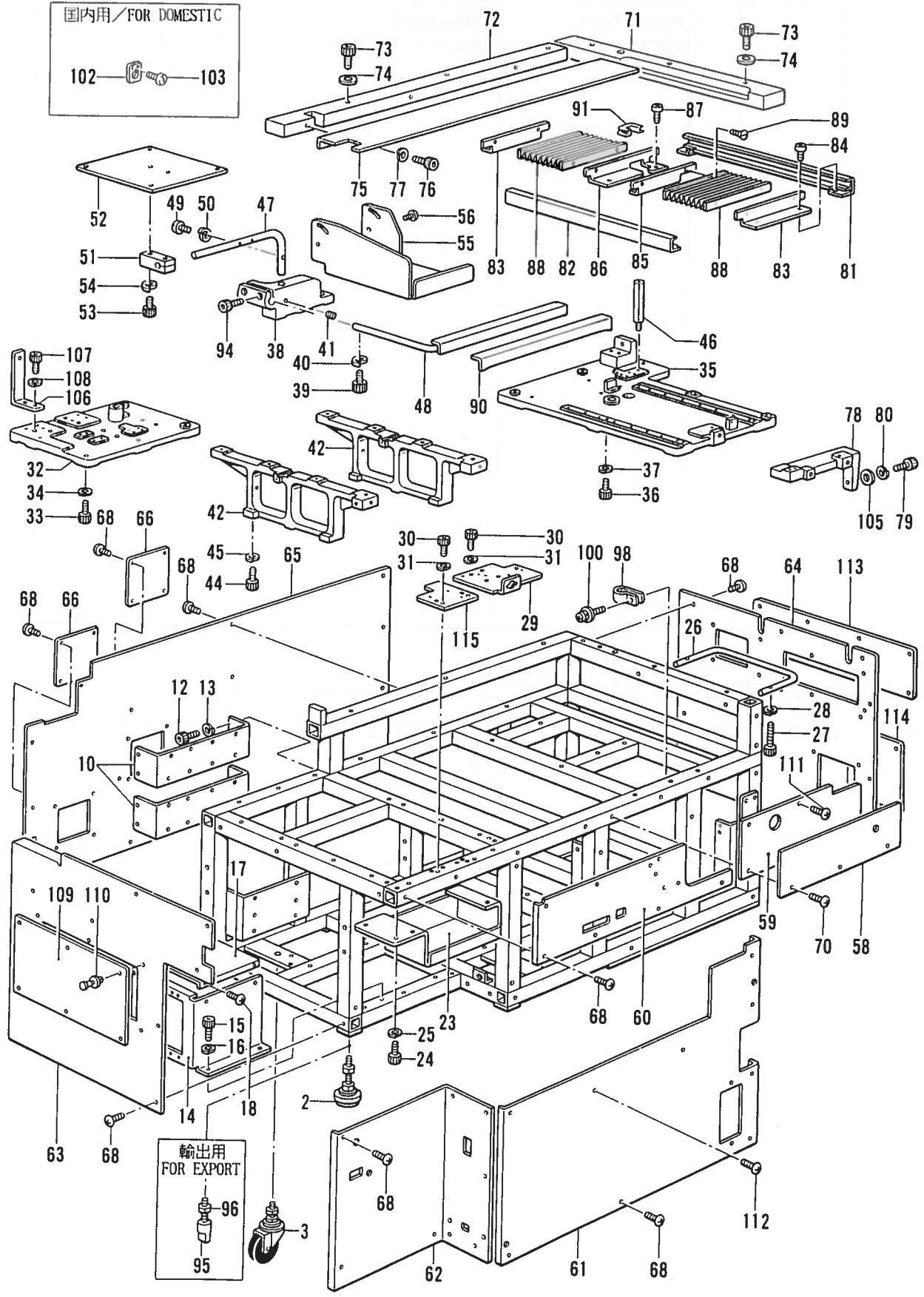

Z1. 動力台関係 / Power table / Motorgestell /
Mécanisme du plateau de la machine / Mecanismo de la mesa de la máquina

REF.NO.	CODE	Q'TY	ヒンメイ	NAME OF PARTS	RMKS
<BAS-752, 750L>					
2	S24777000	8	アジ"ヤスター20	ADJUST SCREW 20	
3	S12225000	4	キヤスター100	CASTER 420	
10	S12230001	2	キハ"ンササエA	CIRCUIT BOARD BASE PLATE (A)	
12	018400832	8	アナホ"ルト4X8	BOLT 4X8	
13	028040242	8	ハ"ネサ"カ"ネ2-4	SPRING WASHER 2-4	
14	S24774001	1	ト"ライハ"ーホ"ツクス	DRIVER BOX	
15	018400832	4	アナホ"ルト4X8	BOLT 4X8	
16	028040242	4	ハ"ネサ"カ"ネ2-4	SPRING WASHER 2-4	
17	S24775001	1	ト"ライハ"ーホ"ツクスウエ	DRIVER BOX UPPER	
18	008400604	4	+トラスコ4X6	SCREW 4X6	
23	S12235009	1	ツールホ"ツクス	TOOL BOX	
24	018400832	4	アナホ"ルト4X8	BOLT 4X8	
25	028040242	4	ハ"ネサ"カ"ネ2-4	SPRING WASHER 2-4	
26	S12236109	1	カ"ート"	GUARD	
27	018502222	2	アナホ"ルト5X22	BOLT 5X22	
28	028050242	2	ハ"ネサ"カ"ネ2-5	SPRING WASHER 2-5	
29	S20850001	1	フロツヒ"ーササエミキ"	FLOPPY SUPPORT (R)	
30	018400822	7	アナホ"ルト4X8	BOLT 4X8	
31	028040242	7	ハ"ネサ"カ"ネ2-4	SPRING WASHER 2-4	
32	S15533009	1	ト"タ"イL	BASE (L)	
33	018082022	7	アナホ"ルト8X20	BOLT 8X20	
34	028080242	7	ハ"ネサ"カ"ネ2-8	SPRING WASHER 2-8	
35	S12239009	1	ト"タ"イR	BASE (R)	
36	018082022	9	アナホ"ルト8X20	BOLT 8X20	
37	028080242	9	ハ"ネサ"カ"ネ2-8	SPRING WASHER 2-8	
38	S15547009	1	ハ"ネルト"タ"イ	PANEL BASE	
39	018082022	3	アナホ"ルト8X20	BOLT 8X20	
40	028080242	3	ハ"ネサ"カ"ネ2-8	SPRING WASHER 2-8	
41	014060632	1	アナトメ6X6クホ"ミ	SET SCREW 6X6	
42	S24564009	2	ハリイタ"タ"イL	NEEDLE PLATE BLACKET (L)	
44	018081422	6	アナホ"ルト8X14	BOLT 8X14	
45	028080242	6	ハ"ネサ"カ"ネ2-8	SPRING WASHER 2-8	
46	S12243001	1	ハリイタ"タ"イA	NEEDLE PLATE BASE (A)	
47	S12244101	1	ハ"ネルササエホ"ウ	PANEL SUPPORT STUD	
48	S12359001	1	ミコ"ロササエ	FRONT SUPPORT	
49	062400616	1	ナヘ"コM4X6	SCREW M4X6	
50	028040243	1	ハ"ネサ"カ"ネ2-4	SPRING WASHER 2-4	
51	S12246001	1	ハ"ネルササエ	PANEL SUPPORT	
52	S12247001	1	ソウサホ"ツクスシタ	OPERATION BOX LOWER	
53	018502522	2	アナホ"ルト5X25	BOLT 5X25	
54	028050242	2	ハ"ネサ"カ"ネ2-5	SPRING WASHER 2-5	
55	S17708009	1	ホ"ケツトウケL	POCKET UNDER TRAY (L)	
56	008400604	4	+トラスコ4X6	SCREW 4X6	
58	*	1	スホ"ンシ"5X220X500	SPONGE 3X170X500	
59	*	1	アテイタ	CAUL	
60	S24969009	1	セ"ンメンカハ"ーヒタ"リ	FRONT COVER LEFT	
61	S24970009	1	セ"ンメンカハ"ーミキ"	FRONT COVER RIGHT	
62	S27932009	1	セ"ンメンカハ"ーL	FRONT COVER (L)	
63	S15557009	1	ソクメンカハ"ーL	FRAME SIDE COVER (L)	
64	S17720009	1	ソクメンカハ"ーR	FRAME SIDE COVER (R)	
65	S24971009	1	ハイメンカハ"ー	REAR COVER	
66	S23763009	2	ハイメンカハ"ーフタ	REAR COVER CAP	
68	008400604	59	+トラスコ4X6	SCREW 4X6	
70	*	3	+サラコ4X8	SCREW 4X8	
71	S24972009	1	テ"ーブルS	TABLE (S)	
72	S24973009	1	テ"ーブルL	TABLE (L)	
73	018401622	6	アナホ"ルト4X16	BOLT 4X16	
74	025040232	6	ヒラサ"カ"ネチユウ4	PLAIN WASHER 4	
75	S24974009	1	テ"ーブルカハ"ー	TABLE COVER	
76	018501222	3	アナホ"ルト5X12	BOLT 5X12	
77	028050242	3	ハ"ネサ"カ"ネ2-5	SPRING WASHER 2-5	

Z1. 動力台関係 / Power table / Motorgestell /
 Mécanisme du plateau de la machine / Mecanismo de la mesa de la máquina

<BAS-752, 750L>

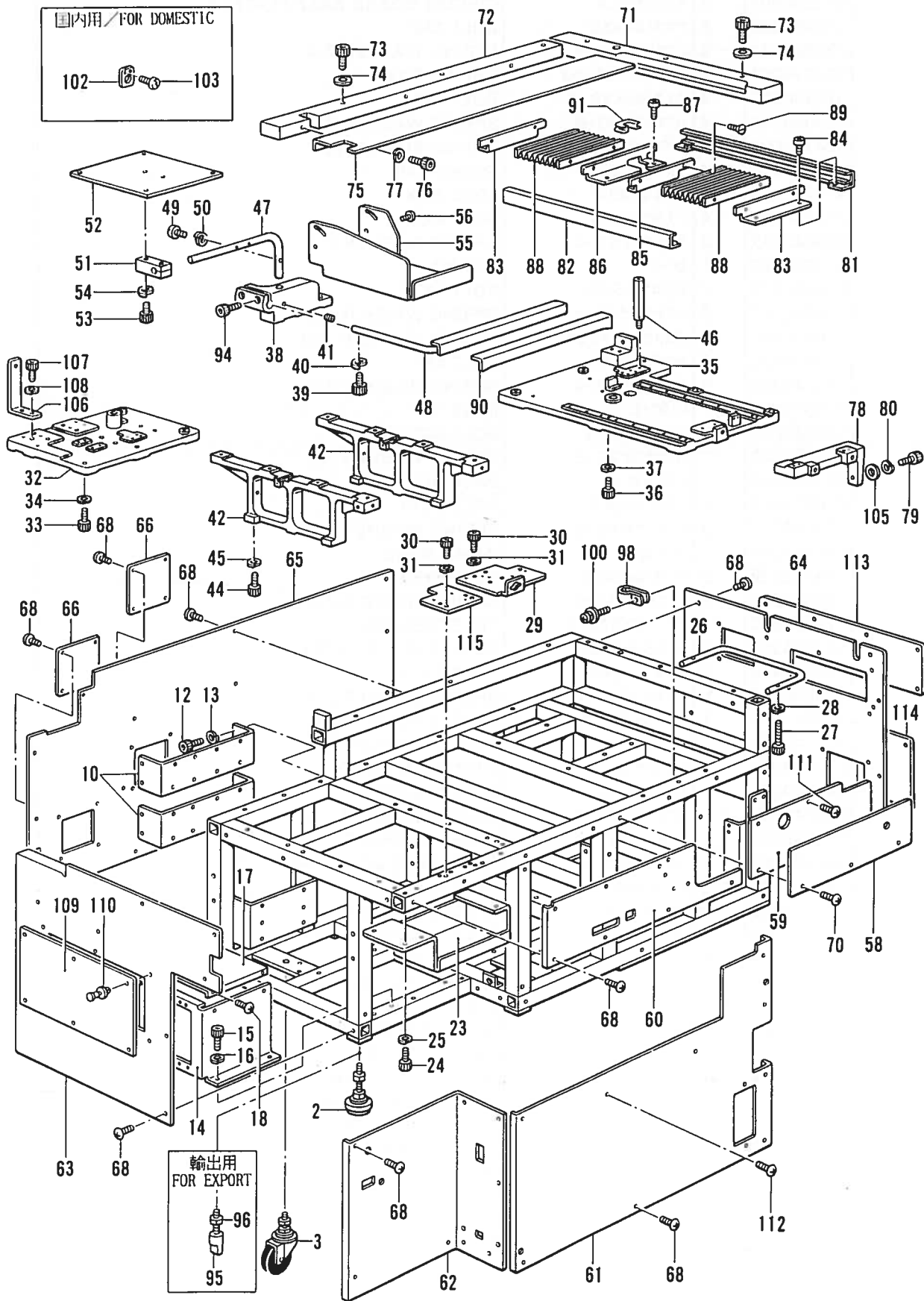

Z1. 動力台関係 / Power table / Motorgestell /
 Mécanisme du plateau de la machine / Mecanismo de la mesa de la máquina

REF.NO.	CODE	Q'TY	ヒンメイ	NAME OF PARTS	RMKS
78	S12260009	1	ローラーササエ	ROLLER SUPPORT	
79	018082022	2	アナボルト8X20	BOLT 8X20	
80	028080242	2	ハネサカネ2-8	SPRING WASHER 2-8	
81	S25075001	1	シヤハラカハ-750	BELLOW COVER 750	
82	S24975001	1	シヤハラカハ-	BELLOW COVER	
83	S24976001	2	シヤハラトリツケイタA	BELLOW SET PLATE (A)	
84	062680612	8	ナヘコ4.37-40X6	SCREW 437X6	
85	S24977001	1	シヤハラトリツケイタB	BELLOW SET PLATE (B)	
86	S25076001	1	シヤハラトリツケイタD	BELLOW SETTING PLATE (D)	
87	062680612	4	ナヘコ4.37-40X6	SCREW 437X6	
88	S24979001	2	シヤハララクミ	BELLOW ASSEMBLY	
89	004400702	8	+サラコ4X7	SCREW 4X7	
90	S12280100	1	スポンジ2X440X60	SPONGE 2X44X60	
91	S12466000	1	シサイフツシユB	FREE BUSH (B)	
94	018502022	2	アナボルト5X20	BOLT 5X20	
95	*	12	-----	STAND	
96	*	12	-----	NUT 20	
98	525907000	1	コートホルダ#9	CORD HOLDER (9N)	
100	052400806	1	ナヘコハネヒラ4X8	WASHER SCREW 4X8	
102	S12506001	1	エアカンフツク	-----	
103	062680612	2	ナヘコ4.37-40X6	-----	
105	025080232	2	ヒラサカネチユウ8	PLAIN WASHER 8	
106	S15528001	2	ハイメンカハ-ササエ	REAR COVER SUPPORT	
107	018401022	4	アナボルト4X10	BOLT 4X10	
108	028040242	4	ハネサカネ2-4	SPRING WASHER 2-4	
109	S15558009	1	ソクメンカハ-Lフタ	FRAME	
110	S12481000	26	ナイラツチ	NYLATCH	
111	*	3	+トラスコ4X8	SCREW 4X8	
112	*	3	+トラスコ4X6	SCREW 4X6	
113	S17722009	1	ソクメンカハ-Rフタウエ	FRAME SIDE COVER (R) UPPER CAP	
114	S17721009	1	ソクメンカハ-Rフタシタ	FRAME SIDE COVER (R) LOWER CAP	
115	S20851000	1	フロツヒ-ササエヒタリ	FLOPPY SUPPORT (L)	

Z2. 動力台関係 / Power table / Motorgestell /
 Mécanisme du plateau de la machine / Mecanismo de la mesa de la máquina

< BAS-754, 750KL >

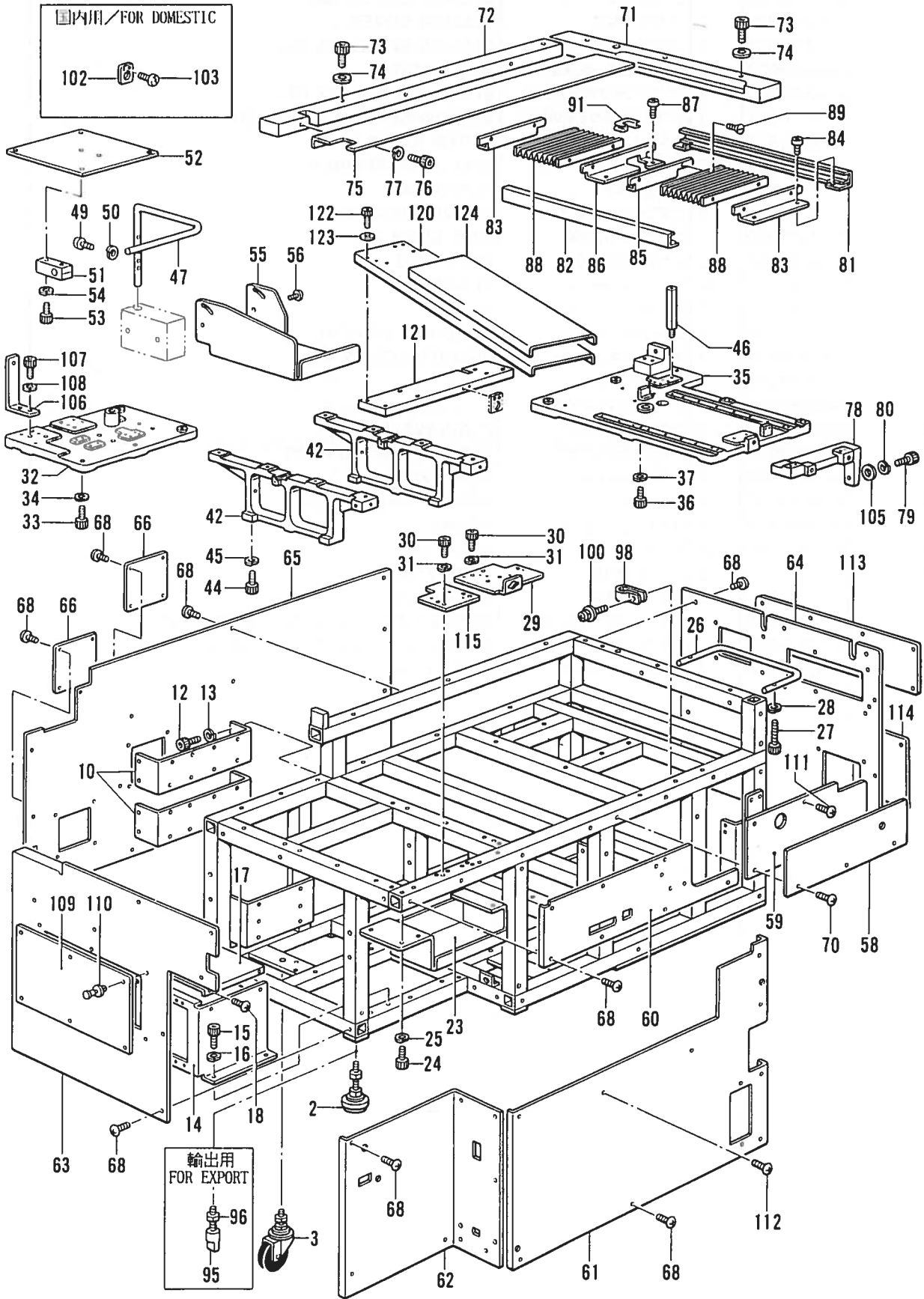

Z2. 動力台関係 / Power table / Motorgestell /
 Mécanisme du plateau de la machine / Mecanismo de la mesa de la máquina

REF. NO.	CODE	Q'TY	ヒンメイ	NAME OF PARTS	RMKS
<BAS-754, 750KL>					
2	S24777000	8	アジ"ヤスター-20	ADJUST SCREW 20	
3	S12225000	4	キヤスター-100	CASTER 100	
10	S12230001	2	キハ"ンササエA	CIRCUIT BOARD BASE PLATE (A)	
12	018400832	8	アナホ"ルト4X8	BOLT 4X8	
13	028040242	8	ハ"ネサ"カ"ネ2-4	SPRING WASHER 2-4	
14	S24774001	1	ト"ライハ"ーホ"ツクス	DRIVER BOX	
15	018400832	4	アナホ"ルト4X8	BOLT 4X8	
16	028040242	4	ハ"ネサ"カ"ネ2-4	SPRING WASHER 2-4	
17	S24775001	1	ト"ライハ"ーホ"ツクスウエ	DRIVER BOX UPPER	
18	008400604	4	+トラスコ4X6	SCREW 4X6	
23	S12235009	1	ツールホ"ツクス	TOOL BOX	
24	018400832	4	アナホ"ルト4X8	BOLT 4X8	
25	028040242	4	ハ"ネサ"カ"ネ2-4	SPRING WASHER 2-4	
26	S12236109	1	ガ"ート"	GUARD	
27	018502222	2	アナホ"ルト5X22	BOLT 5X22	
28	028050242	2	ハ"ネサ"カ"ネ2-5	SPRING WASHER 2-5	
29	S20850001	1	フロツヒ"ーササエミキ"	FLOPPY SUPPORT (R)	
30	018400822	7	アナホ"ルト4X8	BOLT 4X8	
31	028040242	7	ハ"ネサ"カ"ネ2-4	SPRING WASHER 2-4	
32	S15533009	1	ト"タ"イル	BASE (L)	
33	018082022	7	アナホ"ルト8X20	BOLT 8X20	
34	028080242	7	ハ"ネサ"カ"ネ2-8	SPRING WASHER 2-8	
35	S12239009	1	ト"タ"イルR	BASE (R)	
36	018082022	9	アナホ"ルト8X20	BOLT 8X20	
37	028080242	9	ハ"ネサ"カ"ネ2-8	SPRING WASHER 2-8	
40	028080242	3	ハ"ネサ"カ"ネ2-8	SPRING WASHER 2-8	
42	S24564009	2	ハリイタ"ト"タ"イル	NEEDLE PLATE BLACKET (L)	
44	018081422	6	アナホ"ルト8X14	BOLT 8X14	
45	028080242	6	ハ"ネサ"カ"ネ2-8	SPRING WASHER 2-8	
46	S12243001	1	ハリイタ"ト"タ"イA	NEEDLE PLATE BASE (A)	
47	S23402001	1	ハ"ネルササエホ"ウ	PANEL SUPPORT STUD	
49	062400616	1	ナヘ"コM4X6	SCREW M4X6	
50	028040243	1	ハ"ネサ"カ"ネ2-4	SPRING WASHER 2-4	
51	S12246001	1	ハ"ネルササエ	PANEL SUPPORT	
52	S12247001	1	ソウサホ"ツクスシタ	OPERATION BOX LOWER	
53	018502522	2	アナホ"ルト5X25	BOLT 5X25	
54	028050242	2	ハ"ネサ"カ"ネ2-5	SPRING WASHER 2-5	
55	S17708009	1	ホ"ケットウケL	POCKET UNDER TRAY (L)	
56	008400604	4	+トラスコ4X6	SCREW 4X6	
58	*	1	スホ"ンシ"5X220X500	SPONGE 3X170X500	
59	*	1	アテイタ	CAUL	
60	S24969009	1	セ"ンメンカハ"ーヒタ"リ	FRONT COVER LEFT	
61	S24970009	1	セ"ンメンカハ"ーミキ"	FRONT COVER RIGHT	
62	S27932009	1	セ"ンメンカハ"ーL	FRONT COVER (L)	
63	S15557009	1	ソクメンカハ"ーL	FRAME SIDE COVER (L)	
64	S17720009	1	ソクメンカハ"ーR	FRAME SIDE COVER (R)	
65	S24971009	1	ハイメンカハ"ー	REAR COVER	
66	S23763009	2	ハイメンカハ"ーフタ	REAR COVER CAP	
68	008400604	59	+トラスコ4X6	SCREW 4X6	
70	*	3	+サラコ4X8	SCREW 4X8	
71	S24972009	1	テ-フ"ルS	TABLE (S)	
72	S24973009	1	テ-フ"ルL	TABLE (L)	
73	018401622	6	アナホ"ルト4X16	BOLT 4X16	
74	025040232	6	ヒラサ"カ"ネチユウ4	PLAIN WASHER 4	
75	S24974009	1	テ-フ"ルカハ"ー	TABLE COVER	
76	018501222	3	アナホ"ルト5X12	BOLT 5X12	
77	028050242	3	ハ"ネサ"カ"ネ2-5	SPRING WASHER 2-5	
78	S12260009	1	ローラ-ササエ	ROLLER SUPPORT	
79	018082022	2	アナホ"ルト8X20	BOLT 8X20	
80	028080242	2	ハ"ネサ"カ"ネ2-8	SPRING WASHER 2-8	
81	S25075001	1	ジ"ヤハ"ラカハ"ー750	BELLOW COVER 750	

Z2. 動力台関係/Power table/Motorgestell/
 Mécanisme du plateau de la machine/Mecanismo de la mesa de la máquina

<BAS-754, 750KL>

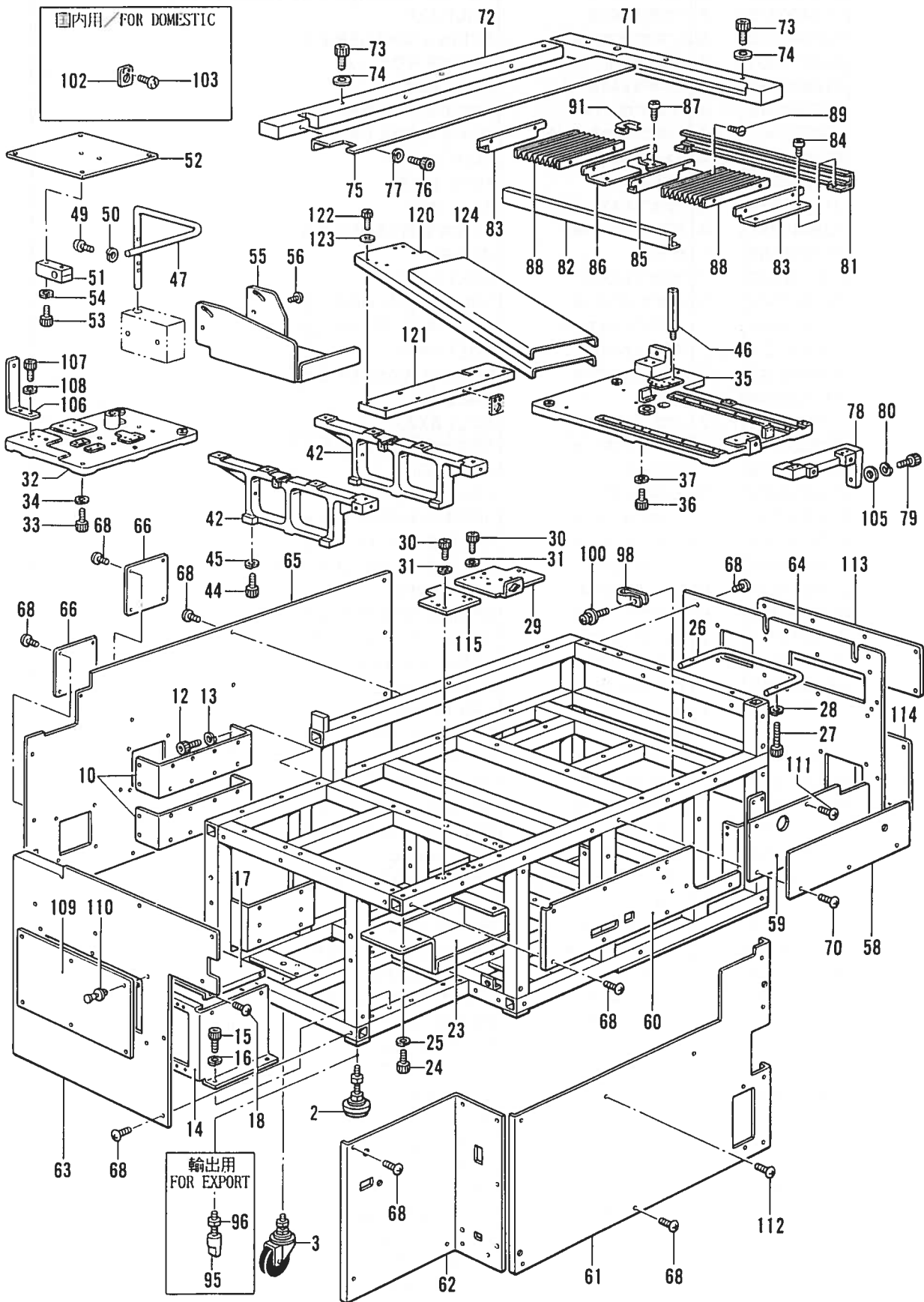

Z2. 動力台関係 / Power table / Motorgestell /
 Mécanisme du plateau de la machine / Mecanismo de la mesa de la máquina

REF.NO.	CODE	Q'TY	ヒンメイ	NAME OF PARTS	RMKS
83	S24976001	2	シ"ヤハ"ラトリツケイタA	BELLOW SET PLATE (A)	
84	062680612	8	ナヘ"コ4.37-40X6	SCREW 437X6	
85	S24977001	1	シ"ヤハ"ラトリツケイタB	BELLOW SET PLATE (B)	
86	S25076001	1	シ"ヤハ"ラトリツケイタD	BELLOW SETTING PLATE (D)	
87	062680612	4	ナヘ"コ4.37-40X6	SCREW 437X6	
88	S24979001	2	シ"ヤハ"ラクミ	BELLOW ASSEMBLY	
89	004400702	8	+サラコ4X7	SCREW 4X7	
91	S12466000	1	シ"サイフ"ツシユB	FREE BUSH (B)	
95	*	12	-----	STAND	
96	*	12	-----	NUT 20	
98	525907000	1	コード"ホルタ"#9	CORD HOLDER (9N)	
100	052400806	1	ナヘ"コハ"ネヒラ4X8	WASHER SCREW 4X8	
102	S12506001	1	エアガ"ンフツク	-----	
103	062680612	2	ナヘ"コ4.37-40X6	-----	
105	025080232	2	ヒラサ"カ"ネチユウ8	PLAIN WASHER 8	
106	S15528001	2	ハイメンカハ"ーササエ	REAR COVER SUPPORT	
107	018401022	4	アナホ"ルト4X10	BOLT 4X10	
108	028040242	4	ハ"ネサ"カ"ネ2-4	SPRING WASHER 2-4	
109	S15558009	1	ソクメンカハ"ーLフタ	FRAME	
110	S12481000	26	ナイラツチ	NYLATCH	
111	*	3	+トラスコ4X8	SCREW 4X8	
112	*	3	+トラスコ4X6	SCREW 4X6	
113	S17722009	1	ソクメンカハ"ーRフタウエ	FRAME SIDE COVER (R) UPPER CAP	
114	S17721009	1	ソクメンカハ"ーRフタシタ	FRAME SIDE COVER (R) LOWER CAP	
115	S20851000	1	フロツヒ"ーササエヒタ"リ	FLOPPY SUPPORT (L)	
120	S24558001	1	ミコ"ロササエイタ	CLOTH PUT SUPPORT PLATE	
121	S24559001	1	ミコ"ロササエイタ"イ	CLOTH PUT SUPPORT BASE	
122	018501222	4	アナホ"ルト5X12	BOLT 5X12	
123	028050242	4	ハ"ネサ"カ"ネ2-5	SPRING WASHER 2-5	
124	S24568000	1	ミコ"ロササエ"ムN	FRONT SUPPORT RUBBER (N)	

AA. 付属装置関係 / Attachment set / Anbausatz /
Jeu d'accessoires / Juego del fijación

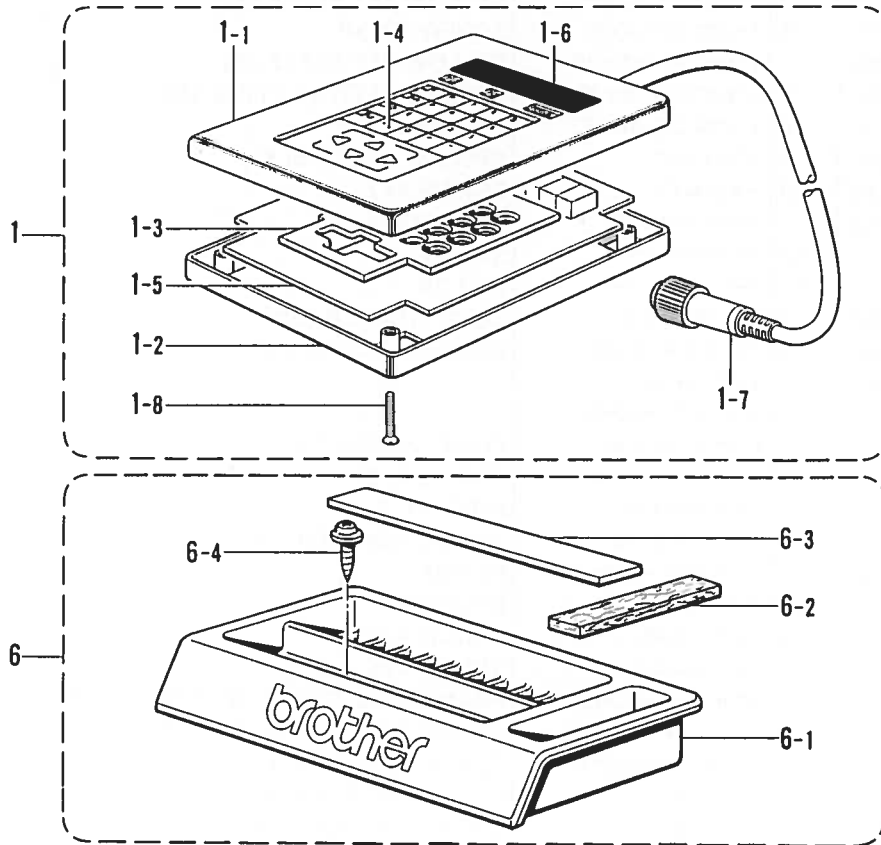

AA. 付属装置関係/Attachment set/Anbausatz/
Jeu d'accessoires/Juego del fijación

REF NO.	CODE	Q'TY	ヒンメイ	NAME OF PARTS	RMKS
1	S02939009	1	プログラマークミ	PROGRAMMER ASSEMBLY	
1-1	S02940001	1	プログラマーハコウエ	PROGRAMMER COVER (U)	
1-2	S02941001	1	プログラマーハコシタ	PROGRAMMER COVER (D)	
1-3	S02942001	1	スペーサー	SPACER	
1-4	S02943009	1	キーボードシート	KEY BOARD SHEET	
1-5	S02947001	1	プログラマーキハ"ンBクミ	PROGRAMMER CIRCUIT BOARD ASSEMBLY (B)	
1-6	S02949001	1	スクリーンパネル	SCREEN PANEL	
1-7	S02950001	1	プログラマーハーネスA	PROGRAMMER HARNESS (A)	
1-8	061302506	4	サラコ3X25	SCREW 3X25	
6	183400009	1	コモノケースセット	ACCESSORY CASE SET	
6-1	S02738009	1	コモノケース	ACCESSORY CASE	
6-2	S02740000	1	フェルト	FELT	
6-3	S02739000	1	ゴムシ"シヤクテープ	RUBBER MAGNET TAPE	
6-4	S10476001	2	ハ"ンワツシヤタツヒ"ンネシ"	SCREW	

AB. 付属装置関係 / Attachment set / Anbausatz /
 Jeu d'accessoires / Juego del fijación

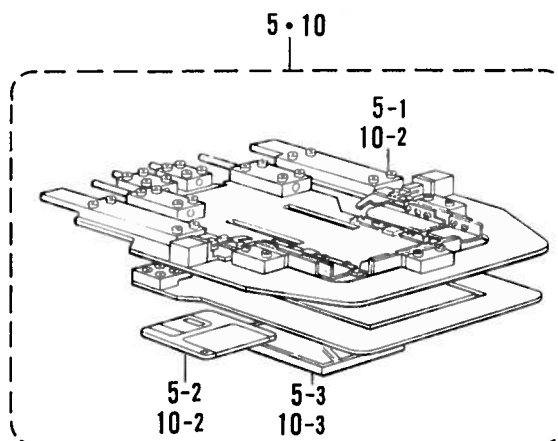
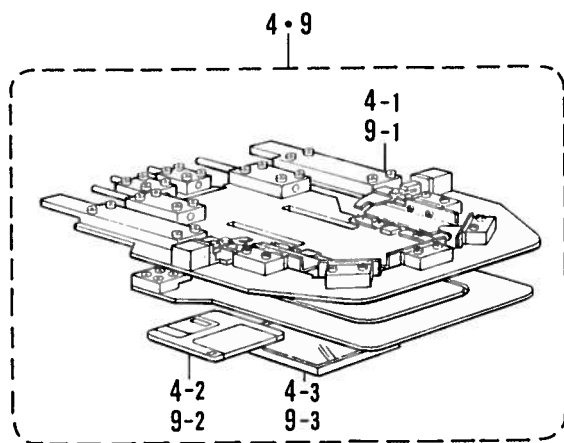
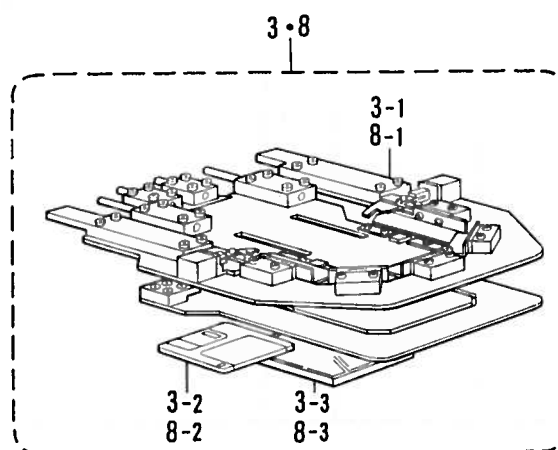
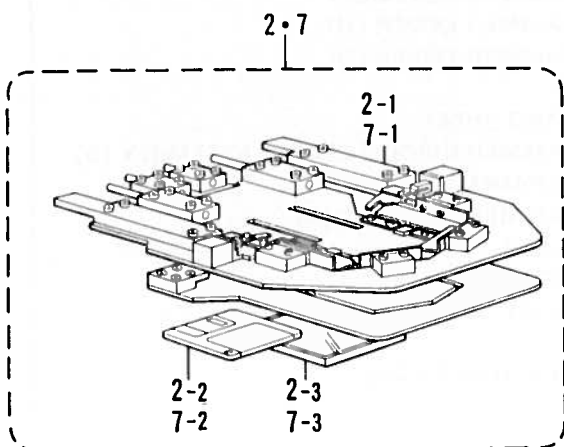

AB. 付属装置関係 / Attachment set / Anbausatz /
Jeu d'accessoires / Juego del fijación

REF.NO.	CODE	Q'TY	ヒンメイ	NAME OF PARTS	RMKS
2	S12272001	1	オリキホキユウクミ-3カク	FOLDING GROUP ASSEMBLY (TRIANGLE)	
2-1	S12283001	1	オリキクミ-3カク	FOLDING GROUP ASSEMBLY (TRIANGLE)	
2-2	U42775001	1	3.5メデ"イア 2DD	3.5-MEDIA 2DD	
2-3	S09989000	1	フロッピーケース	FLOPPY CASE	
3	S12273001	1	オリキホキユウクミ-5カク	FOLDING GROUP ASSEMBLY (MITER)	
3-1	S12305001	1	オリキクミ-5カク	FOLDING GROUP ASSEMBLY (MITER)	
3-2	U42775001	1	3.5メデ"イア 2DD	3.5-MEDIA 2DD	
3-3	S09989000	1	フロッピーケース	FLOPPY CASE	
4	S12274001	1	オリキホキユウクミ-マル	FOLDING GROUP ASSEMBLY (ROUND)	
4-1	S12323001	1	オリキクミ-マル	FOLDING GROUP ASSEMBLY (ROUND)	
4-2	U42775001	1	3.5メデ"イア 2DD	3.5-MEDIA 2DD	
4-3	S09989000	1	フロッピーケース	FLOPPY CASE	
5	S12281001	1	オリキホキユウクミ-4カク	FOLDING GROUP SUPPLY ASSEMBLY (SQUARE)	
5-1	S12341001	1	オリキクミ-4カク	FOLDING GROUP ASSEMBLY (SQUARE)	
5-2	U42775001	1	3.5メデ"イア 2DD	3.5-MEDIA 2DD	
5-3	S09989000	1	フロッピーケース	FLOPPY CASE	
7	S12488001	1	オリキホキユウクミ-3カクL	FOLDING GROUP SUPPLY ASSY (TRIANGLE-L)	
7-1	S12283001	1	オリキクミ-3カク	FOLDING GROUP ASSEMBLY (TRIANGLE)	
7-2	U42775001	1	3.5メデ"イア 2DD	3.5-MEDIA 2DD	
7-3	S09989000	1	フロッピーケース	FLOPPY CASE	
8	S12489001	1	オリキホキユウクミ-5カクL	FOLDING GROUP SUPPLY ASSEMBLY (MITER-L)	
8-1	S12305001	1	オリキクミ-5カク	FOLDING GROUP ASSEMBLY (MITER)	
8-2	U42775001	1	3.5メデ"イア 2DD	3.5-MEDIA 2DD	
8-3	S09989000	1	フロッピーケース	FLOPPY CASE	
9	S12490001	1	オリキホキユウクミ-マルL	FOLDING GROUP SUPPLY ASSEMBLY (ROUND-L)	
9-1	S12323001	1	オリキクミ-マル	FOLDING GROUP ASSEMBLY (ROUND)	
9-2	U42775001	1	3.5メデ"イア 2DD	3.5-MEDIA 2DD	
9-3	560196000	4	ケースヨウフクロ	PLASTIC BAG	
9-4	S09989000	1	フロッピーケース	FLOPPY CASE	
10	S12491001	1	オリキホキユウクミ-4カクL	FOLDING GROUP SUPPLY ASSEMBLY(SQUARE-L)	
10-1	S12341001	1	オリキクミ-4カク	FOLDING GROUP ASSEMBLY (SQUARE)	
10-2	U42775001	1	3.5メデ"イア 2DD	3.5-MEDIA 2DD	
10-3	S09989000	1	フロッピーケース	FLOPPY CASE	

AC. 付属品関係/Accessories/Zubehör/
Accessoires/Accessorios

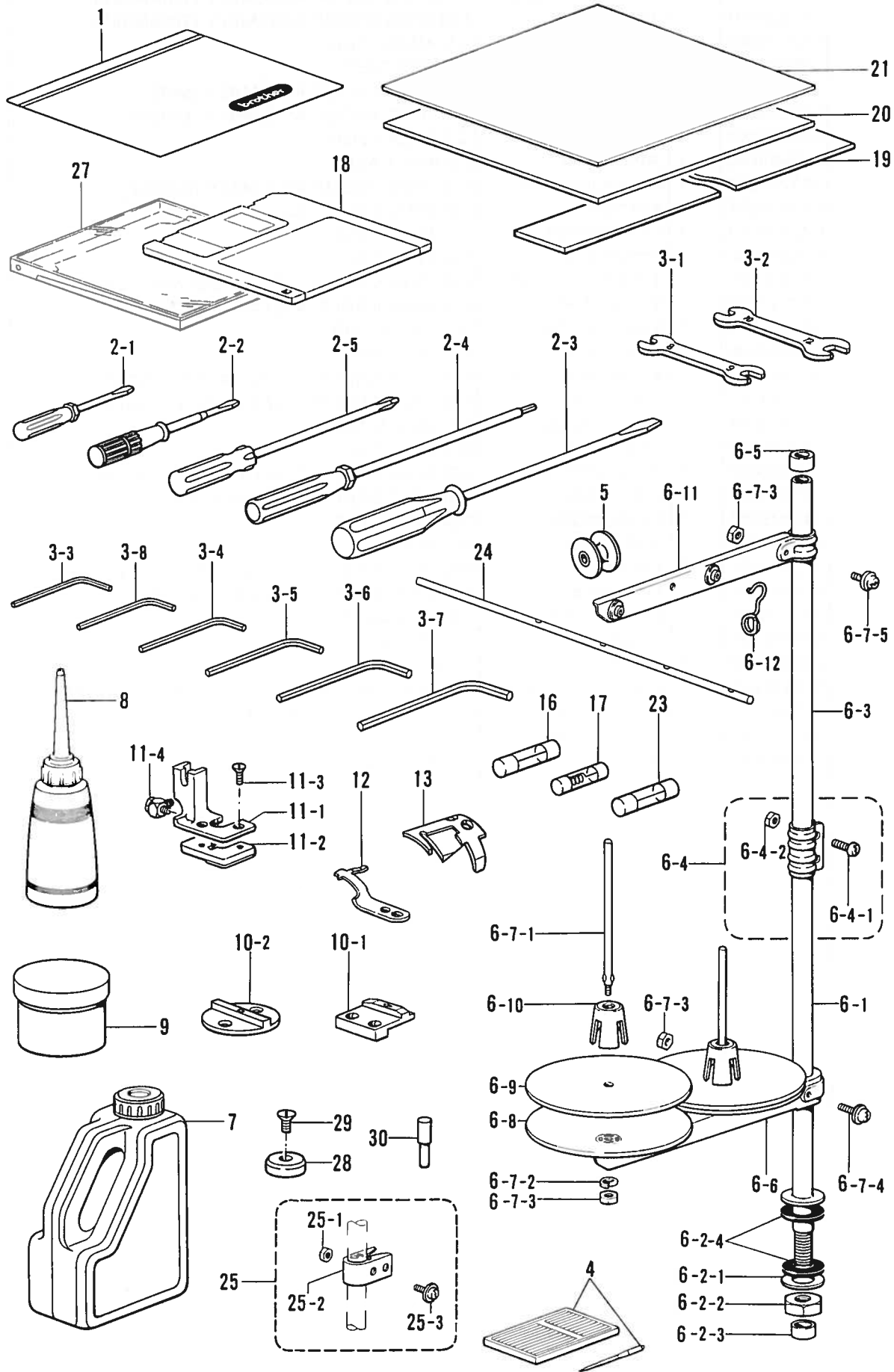

◎ 付属品の明細は変更することがあります。
 ◎ The details of included accessories are subject to change.
 ◎ Änderungen in der Aufstellung der Mitgelieferten Zubehöre sind vorbehalten.

◎ Les détails des accessoires inclus sont sujets à des changements.
 ◎ Los detalles de los accesorios incluidos pueden variar.

AC. 付属品関係/Accessories/Zubehör/
Accessoires/Accessorios

REF NO.	CODE	Q'TY	ヒンメイ	NAME OF PARTS	RMKS
1	122991001	1	フゾクヒンホリフクロ	ACCESSORY BAG	
2-1	142443001	1	ネシマフシ1.9X52	SCREW DRIVER 1.9X52	
2-2	118837001	1	ネシマフシ3.4X70	SCREW DRIVER 3.4X70	
2-3	101572101	1	ネシマフシ5.5X190	SCREW DRIVER 5.5X190	
2-4	149173001	1	6カクホウネシマフシ3	SCREW DRIVER 3	
2-5	150332001	1	プラストライハ-NO.2	DRIVER NO.2	
3-1	100887001	1	スパナ8X9	SPANNER 8X9	
3-2	107780001	1	スパナ10X12	SPANNER 10X12	
3-3	146049001	1	6カクホウスパナ2	HEXAGONAL WRENCH 2	
3-4	142721001	1	6カクホウスパナ3	HEXAGONAL WRENCH 3	
3-5	118064001	1	6カクホウスパナ4	HEXAGONAL WRENCH 4	
3-6	150335001	1	6カクホウスパナ5	HEXAGONAL WRENCH 5	
3-7	115157001	1	6カクホウスパナ6	HEXAGONAL WRENCH 6	
3-8	154125001	1	6カクホウスパナ2.5	HEXAGONAL WRENCH 2.5	
5	146290001	3	ホビツ	BOBBIN	
6	S02763202	1	イトタテグアイクミ2DR	COTTON STAND ASSEMBLY 2DR	
6-1	156112003	1	コラムパイプD	COLUMN PIPE (D)	
6-2	S02777001	1	パイプDネシマセットB	PIPE (D) SCREW SET (B)	
6-2-1	150206002	1	ヒラサカネ16	PLAIN WASHER 16	
6-2-2	150191002	1	6カクナツ5/8	NUT 5/8	
6-2-3	150174000	1	コラムキャップ	COLUMN CAP	
6-2-4	S01005000	2	イトタテゴム	RUBBER WASHER	
6-3	150172003	1	コラムパイプ	COLUMN PIPE	
6-4	150106003	1	コラムジョイントクミ	COLUMN JOINT ASSEMBLY	
6-4-1	062501406	2	ナヘコ5X14	SCREW 5X14	
6-4-2	021500106	2	1シユナツ5	NUT 5	
6-5	150174000	1	コラムキャップ	COLUMN CAP	
6-6	S02778002	1	スプールホルダ-2	SPOOL HOLDER 2	
6-7	S02780001	1	スプールネシマセット2	SPOOL SCREW SET 2	
6-7-1	150179002	2	スプールシク	SPOOL SHAFT (B)	
6-7-2	028050246	2	ハネサカネ2-5	SPRING WASHER 2-5	
6-7-3	021500106	4	1シユナツ5	NUT 5	
6-7-4	050503006	1	ナヘコヒラサ5X30	WASHER SCREW 5X30	
6-7-5	050501406	1	ナヘコヒラサ5X14	WASHER SCREW 5X14	
6-8	150180001	2	ウケサラ	SPOOL STAND BASE	
6-9	150182000	2	スプールマット	SPOOL MAT	
6-10	126863001	2	スプールクッション	SPOOL CUSHION	
6-11	S02786002	1	スレツハンガークミ2	THREAD HANGER ASSEMBLY 2	
6-12	S02747101	1	イトカケハネ	SPRING	
7	154702001	1	オイルタンク	OIL TANK	
8	114483002	1	ホリオイラークミ	OILER ASSEMBLY	
9	S00966000	1	グリースタンク30	GREASE TUNK 30	
11	S19063101	1	オサエアシクミ	WORK CLAMP ASSEMBLY	
11-1	S19064001	1	オサエアシ	WORK CLAMP	
11-2	S19065101	1	オサエイタ	PRESSER PLATE	
11-3	102538007	2	サラネシ3.57	SCREW 3.57	
11-4	S19068000	1	エルホM3	ELBOW M3	
12	S02637001	1	コテイハ	FIXED KNIFE	
13	S02645001	1	イトウハ	MOVABLE KNIFE	
16	S04173000	2	ヒューズ20A	FUSE 20A	
17	152565000	2	ヒューズB	FUSE (B)	
18	U42775001	2	3.5メデア 2DD	3.5-MEDIA 2DD	
19	S12298000	1	フォーム3X15X1000	FORM 3X15X1000	
20	S12116000	1	スポンジ3X200X200	SPONGE 3X200X200	
21	S12117000	1	フォーム2X200X200	FORM 2X200X200	
23	S20038000	2	ヒューズ3A	FUSE 3A	
24	S11959001	1	シタイトアンナイ	LOWER THREAD GUIDE	
25	150145009	1	イトアンナイホルダークミ	THREAD GUIDE HOLDER ASSEMBLY	
25-1	021500106	1	1シユナツ5	NUT 5	
25-2	150185009	1	イトアンナイホルダ-	THREAD GUIDE HOLDER	
25-3	050503006	1	ナヘコヒラサ5X30	WASHER SCREW 5X30	
27	S09989000	2	フロツピケース	FLOPPY CASE	

AC. 付属品関係/Accessories/Zubehör/
 Accessoires/Accesorios

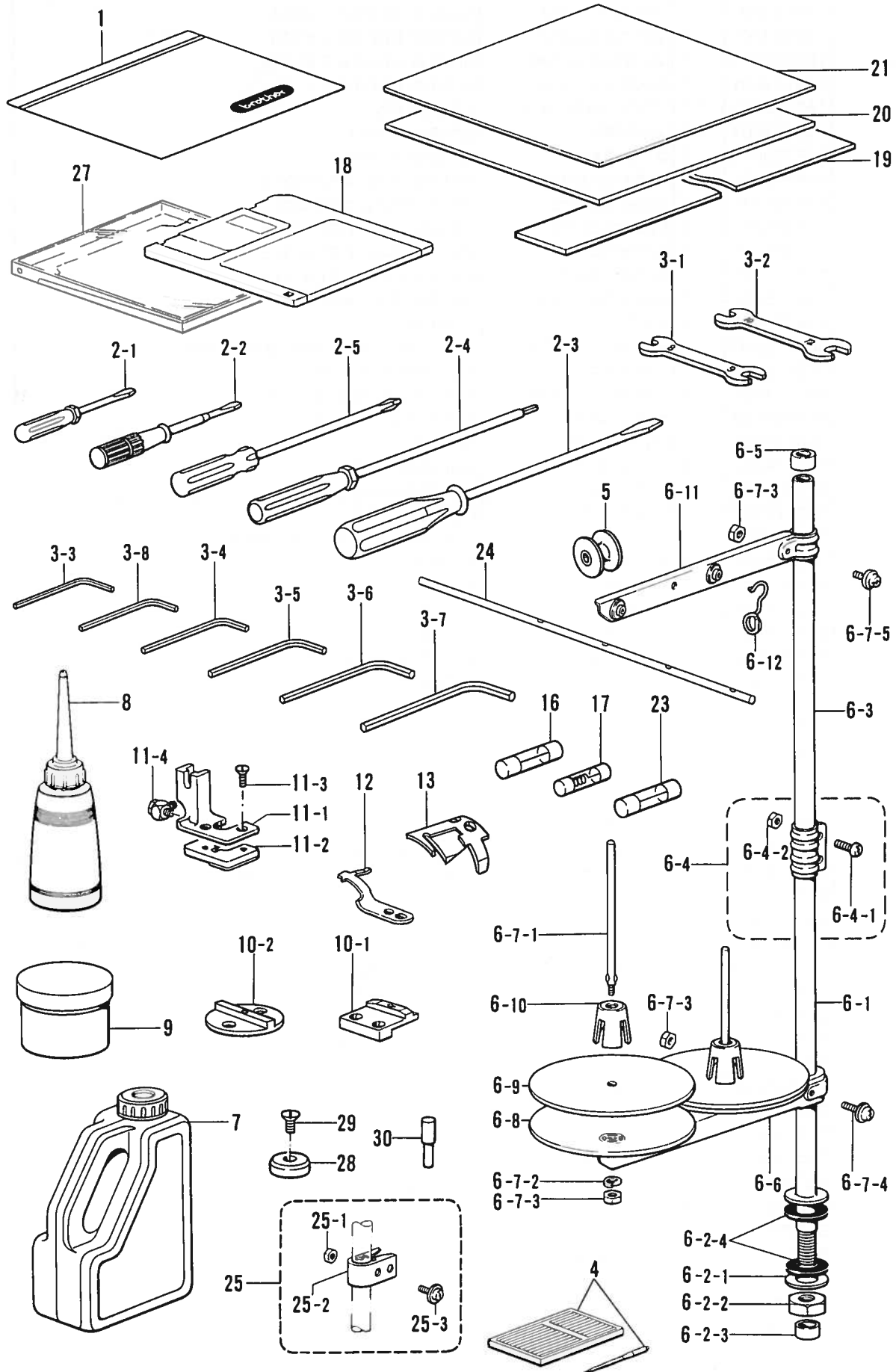

◎ 付属品の明細は変更することがあります。
 ◎ The details of included accessories are subject to change.
 ◎ Änderungen in der Aufstellung der Mitgelieferten Zubehöre sind vorbehalten.

◎ Les détails des accessoires inclus sont sujets à des changements.
 ◎ Los detalles de los accesorios incluidos pueden variar.

AC. 付属品関係/Accessories/Zubehör/
Accessoires/Accessorios

REF NO.	CODE	Q'TY	ヒンメイ	NAME OF PARTS	RMKS
28	S11857000	4	ハリイタウケ	NEEDLE PLATE SUPPORT	
29	107272002	4	サラネジ"4.37	SCREW 4.37	
30	S24773001	2	イチキ"メピン	POSITIONING PIN	
<BAS-752, 750L>					
4	S11864009	10	ミシンハリ134SERV7 (#65)	NEEDLE 134SERV7 (#65)	
4	S11864010	10	ミシンハリ134SERV7 (#70)	NEEDLE 134SERV7 (#70)	
4	S11864012	10	ミシンハリ134SERV7 (#80)	NEEDLE 134SERV7 (#80)	
4	S11864014	10	ミシンハリ134SERV7 (#90)	NEEDLE 134SERV7 (#90)	
10-1	S11889001	1	ホ"トムフランシ"ヤ	BOTTOM PLUNGER	
<BAS-754, 750KL>					
4	S25077009	10	ミシンハリ134SES (#65)	NEEDLE 134SES (#65)	
4	S25077010	10	ミシンハリ134SES (#70)	NEEDLE 134SES (#70)	
4	S25077012	10	ミシンハリ134SES (#80)	NEEDLE 134SES (#80)	
10-2	S24553001	1	ハリアナイト	NEEDLE HOLE PLATE	

仕様別一覧表/DIFFERENT PARTS LIST/ZUBEHÖRLISTE/
LISTE DES PIÈCES ACCESSOIRES/LISTA DE PIEZAS ACCESORIAS

REF.NO.	サブクラス SUB CLASS ヒンメイ PARTS	BAS-752.754 201-11 200V コクナイヨウ FOR DOMESTIC	BAS-752 221-11 200V コクナイヨウ FOR DOMESTIC	BAS-752,754 301-11 200V コクナイヨウ FOR DOMESTIC	BAS-752 321-11 200V コクナイヨウ FOR DOMESTIC	
U1-7	バルブ"8クミ VALVE 8 ASSEMBLY	-----	-----	S19527000	←	
U1-57	エアホース4X2.5-15 AIR TUBE 4X2.5-15	S12191000	←	←	←	
U1-84	----- 1/4PT CAP	-----	-----	-----	-----	
U1-94	エアホース4X2.5-15 AIR TUBE 4X2.5-15	-----	-----	S12191000	←	
U1-95	エアホース4X2.5-17 AIR TUBE 4X2.5-17	-----	-----	S12193000	←	
U1-96	エアホース4X2.5-20 AIR TUBE 4X2.5-20	-----	-----	S12196000	←	
U1-97	エアホース4X2.5-21 AIR TUBE 4X2.5-21	-----	-----	S12197000	←	
U2-10	バルブ"2クミ -----	S19675000	←	-----	-----	
U2-78	----- TANK UNIT	-----	-----	-----	-----	
U2-79	ハキュームソウチクミ (BAS-752,750L) VACUUM EQUIPMENT ASSY (BAS-752, 750L)	-----	S12496001	-----	S12496001	
U2-79	ハキュームソウチクミ (BAS-754,750KL) VACUUM EQUIPMENT ASSY (BAS-754, 750KL)	S12496001	-----	S12496001	-----	
U2-86	ハキュームウラフタ -----	S15544001	-----	S15544001	-----	
U2-87	サラネシ"4.37 -----	100032003	-----	100032003	-----	
V1-104	----- TERMINAL HARNESS	-----	-----	-----	-----	
V1-105	----- FUZE 0.5A	-----	-----	-----	-----	
V1-106	----- TERMINAL BLOCK 2P	-----	-----	-----	-----	
V1-107	----- BOLT4X12	-----	-----	-----	-----	
V1-108	----- SPRING WASHER 2-4	-----	-----	-----	-----	

REF.NO.	ヒンメイ PARTS	サブクラス SUB CLASS	BAS-752.754 201-11 200V コクナイヨウ FOR DOMESTIC	BAS-752 221-11 200V コクナイヨウ FOR DOMESTIC	BAS-752.754 301-11 200V コクナイヨウ FOR DOMESTIC	BAS-752 321-11 200V コクナイヨウ FOR DOMESTIC	
V2-103	----- HAND SWITCH ASSEMBLY		-----	-----	-----	-----	
X-4	PROM 750-2 (BAS-752,750L) ----- PROM 750-2 (BAS-752,750L)		S11837300	←	←	←	
X-4	PROM 750-2 (BAS-754,750KL) ----- PROM 750-2 (BAS-754,750KL)		S25518101	-----	S25518101	-----	
Z1-58	スポンジ5X220X500 ----- SPONGE 5X220X500		-----	-----	S12249000	←	
Z1-59	アテイタ ----- CAUL		S12250009	←	←	←	
Z1-70	+サラコ4X8 ----- SCREW 4X8		004400804	←	←	←	
Z1-95	----- ----- STAND		-----	-----	-----	-----	
Z1-96	----- ----- NUT 20		-----	-----	-----	-----	
Z1-111	+トラスコ4X8 ----- SCREW 4X8		008400806	←	←	←	
Z1-112	+トラスコ4X6 ----- SCREW 4X6		008400604	←	←	←	
Z2-58	スポンジ5X220X500 ----- SPONGE 5X220X500		-----	-----	S12249000	-----	
Z2-59	アテイタ ----- CAUL		S12250009	-----	S12250009	-----	
Z2-70	+サラコ4X8 ----- SCREW 4X8		004400804	-----	004400804	-----	
Z2-95	----- ----- STAND		-----	-----	-----	-----	
Z2-96	----- ----- NUT 20		-----	-----	-----	-----	
Z2-111	+トラスコ4X8 ----- SCREW 4X8		008400806	-----	008400806	-----	
Z1-112	+トラスコ4X6 ----- SCREW 4X6		008400604	-----	008400604	-----	
	----- -----						

REF.NO.	サブクラス SUB CLASS ヒンメイ PARTS	BAS-750L, 750KL	BAS-750L, 750KL	BAS-750L, 750KL	BAS-752,754	
		312-02 220V ユシュツヨウ FOR EXPORT	312-03 380V ユシュツヨウ FOR EXPORT	312-04 415V ユシュツヨウ FOR EXPORT	401-11 200V コクナイヨウ FOR DOMESTIC	
U1-7	バルブ8クミ VALVE 8 ASSEMBLY	S19527000	←	←	←	
U1-57	エアース4X2.5-15 AIR TUBE 4X2.5-15	S12191000	←	←	-----	
U1-84	----- 1/4PT CAP	140542001	←	←	-----	
U1-94	エアース4X2.5-15 AIR TUBE 4X2.5-15	S12191000	←	←	←	
U1-95	エアース4X2.5-17 AIR TUBE 4X2.5-17	S12193000	←	←	←	
U1-96	エアース4X2.5-20 AIR TUBE 4X2.5-20	S12196000	←	←	←	
U1-97	エアース4X2.5-21 AIR TUBE 4X2.5-21	S12197000	←	←	←	
U2-10	バルブ2クミ ----- -----	-----	-----	-----	-----	
U2-78	----- TANK UNIT	S12495001	←	←	-----	
U2-79	ハキュームソウチクミ (BAS-752,750L) VACUUM EQUIPMENT ASSY (BAS-752, 750L)	S12496001	←	←	-----	
U2-79	ハキュームソウチクミ (BAS-754,750KL) VACUUM EQUIPMENT ASSY (BAS-754, 750KL)	S12496001	←	←	←	
U2-86	ハキュームウラフタ ----- -----	-----	-----	-----	S15544001	
U2-87	サラネシ4.37 ----- -----	-----	-----	-----	100032003	
V1-104	----- TERMINAL HARNESS	S25584000	←	←	-----	
V1-105	----- FUSE 0.5A	151827000	←	←	-----	
V1-106	----- TERMINAL BLOCK 2P	S11708000	←	←	-----	
V1-107	----- BOLT4X12	018401222	←	←	-----	
V1-108	----- SPRING WASHER 2-4	028040242	←	←	-----	

REF.NO.	サブクラス SUB CLASS ヒンメイ PARTS	BAS-750L, 750KL	BAS-750L, 750KL	BAS-750L, 750KL	BAS-752,754	
		312-02 220V エシツツヨウ FOR EXPORT	312-03 380V エシツツヨウ FOR EXPORT	312-04 415V エシツツヨウ FOR EXPORT	401-11 200V コクナイヨウ FOR DOMESTIC	
V2-103	----- HAND SWITCH ASSEMBLY	S12467001	←	←	-----	
X-4	PROM 750-2 (BAS-752,750L) ----- PROM 750-2 (BAS-752,750L)	S11837300	←	←	S12057200	
X-4	PROM 750-2 (BAS-754,750KL) ----- PROM 750-2 (BAS-754,750KL)	S25518101	←	←	S12057200	
Z1-58	スポンジ5X220X500 ----- SPONGE 5X220X500	S12249000	←	←	-----	
Z1-59	アテイタ ----- CAUL	S12250009	←	←	-----	
Z1-70	+サラコ4X8 ----- SCREW 4X8	004400804	←	←	-----	
Z1-95	----- ----- STAND	S12356001	←	←	-----	
Z1-96	----- ----- NUT 20	021200203	←	←	-----	
Z1-111	+トラスコ4X8 ----- SCREW 4X8	008400806	←	←	-----	
Z1-112	+トラスコ4X6 ----- SCREW 4X6	008400604	←	←	-----	
Z2-58	スポンジ5X220X500 ----- SPONGE 5X220X500	S12249000	←	←	-----	
Z2-59	アテイタ ----- CAUL	S12250009	←	←	-----	
Z2-70	+サラコ4X8 ----- SCREW 4X8	004400804	←	←	-----	
Z2-95	----- ----- STAND	S12356001	←	←	-----	
Z2-96	----- ----- NUT 20	021200203	←	←	-----	
Z2-111	+トラスコ4X8 ----- SCREW 4X8	008400806	←	←	-----	
Z2-112	+トラスコ4X6 ----- SCREW 4X6	008400604	←	←	-----	
	----- -----					

索引/INDEX/VERZEICHNIS/
INDEX/INDICE

CODE	REF.NO.	PAGE
S00337001	R - 1	66
S00480000	K1 - 77	52
	S - 11	68
	V2 - 126	82
S00879001	D - 8	8
S00966000	AC - 9	102
S01005000	AC - 6-2-4	102
S01040001	L - 34	56
S01208000	U2 - 79-1-2	74
S01234000	B - 5	4
	L - 30	56
	L - 7	56
S01522000	U1 - 1-2-7	70
	U1 - 1-3-7	70
	U1 - 18-2	70
	U2 - 78-1-3	74
	U2 - 79-1-3	74
S01542000	U1 - 1-2-8	70
	U1 - 1-3-6	70
	U1 - 7-6	70
	U2 - 10-4	74
S01824000	T - 1-2	68
S01998001	D - 14	8
S02525001	B - 9	4
S02526000	B - 9-1	4
S02527001	B - 12	4
S02546201	D - 15	8
S02551001	D - 38	8
S02611001	P - 1-1	62
S02612001	P - 1-2	62
S02614109	P - 10	62
S02617001	P - 14	62
S02620001	P - 17-4	62
S02624001	P - 17-8	62
S02637001	AC - 12	102
	R - 4	66
S02643001	R - 6	66
S02645001	AC - 13	102
	R - 13	66
S02647001	R - 22	66
S02648001	R - 23	66
S02652001	R - 39	66
S02655001	R - 43	66
S02657001	A - 39	2
	R - 48	66
S02658001	S - 1	68
S02738009	AA - 6-1	98
S02739000	AA - 6-3	98
S02740000	AA - 6-2	98
S02747101	AC - 6-12	102
S02763202	AC - 6	102
S02777001	AC - 6-2	102
S02778002	AC - 6-6	102
S02780001	AC - 6-7	102
S02786002	AC - 6-11	102
S02915100	V2 - 88	80
S02939009	AA - 1	98
S02940001	AA - 1-1	98
S02941001	AA - 1-2	98
S02942001	AA - 1-3	98
S02943009	AA - 1-4	98
S02947001	AA - 1-5	98
S02949001	AA - 1-6	98
S02950001	AA - 1-7	98
S03245001	L - 24	56
S03246001	L - 24-4	56
S03254001	P - 17-1	62

CODE	REF.NO.	PAGE
S03670001	S - 9	68
S04159000	E3 - 128-63	18
	J1 - 1-1-42	28
	J2 - 2-1-42	34
	J3 - 3-1-42	40
	J4 - 4-1-41	46
	N1 - 4	58
	U1 - 71	72
	V2 - 103-6	82
	V2 - 90	80
	W1 - 20	84
	W2 - 21	86
S04173000	AC - 16	102
	V1 - 1-8	76
S04557000	V1 - 1-13	76
S04587000	F - 80	22
S04782000	K1 - 9	52
S04891000	U1 - 85	72
S04896000	U1 - 14-2	70
	U2 - 79-9	74
S04897000	U1 - 1-2-9	70
	U1 - 7-4	70
	U2 - 10-2	74
S04905000	E3 - 128-23-2	16
	J1 - 1-1-53-2	28
	J2 - 2-1-55-2	34
	J3 - 3-1-56-2	40
	J4 - 4-1-60-2	48
	U1 - 1-7	70
	U1 - 24-2	70
S04907000	F - 16	20
S04909000	D - 29-3	8
	E1 - 14-2	10
	F - 13-2	20
	U1 - 1-3-5	70
S04910000	D - 29-2	8
	K1 - 14-2	52
S04993000	V1 - 5-14	76
S05035000	V2 - 57-1	80
S06143000	V1 - 155	78
S06550001	T - 1-1	68
S06551101	T - 1-1-1	68
S06552000	T - 1-1-2	68
S06857000	U1 - 83	72
S06858000	U1 - 83-1	72
S06859000	U1 - 83-2	72
S07229101	N2 - 33	60
S07467001	S - 12	68
S07469001	N2 - 87	60
S07478000	N2 - 58	60
	N2 - 75	60
S07901000	P - 19	62
S07972001	P - 5	62
S08017000	W1 - 14-1-1	84
	W1 - 18-4-1-1	84
	W2 - 12-1-1	86
S08106000	V1 - 7	78
S08119000	V2 - 47-1	80
	V2 - 61-1	80
S08137000	W1 - 19	84
	W2 - 22	86
S09027001	E2 - 98	12
S09141000	V1 - 54	76
S09197000	A - 35	2
S09231000	U1 - 14-1	70
S09989000	AB - 10-3	100
	AB - 2-3	100

CODE	REF.NO.	PAGE
S09989000	AB- 3-3	100
	AB- 4-3	100
	AB- 5-3	100
	AB- 7-3	100
	AB- 8-3	100
	AB- 9-4	100
	AC- 27	102
S10243000	G - 47	24
S10287000	V1 - 7	78
S10315000	V1 - 1-6	76
S10335001	V1 - 24	76
S10476001	AA- 6-4	98
S11182009	P - 17-9	62
S11183009	P - 17-9-1	62
S11184009	P - 17-9-1-1	62
S11426000	E1 - 38-3	10
	E2 - 107-2	14
	E2 - 115-2	14
	E2 - 47-3	12
	E3 - 128-17-4	16
	K2 - 27-2	54
	K2 - 33-2	54
	K2 - 36-4	54
	K2 - 37-4	54
S11433000	F - 29-2	20
	J1 - 1-1-13-2	28
	J1 - 1-1-39-2	28
	J2 - 2-1-13-2	34
	J2 - 2-1-39-2	34
	J3 - 3-1-13-2	40
	J3 - 3-1-39-2	40
	J4 - 4-1-13-2	46
	J4 - 4-1-38-2	46
	K1 - 56-2	52
	U1 - 88-2	72
S11693000	V2 - 35	80
S11694000	V2 - 45	80
S11696100	V2 - 47	80
S11697000	V2 - 48	80
S11698000	V2 - 49	80
S11700000	V2 - 51	80
S11701000	V2 - 52	80
S11702000	V1 - 32	76
S11703000	V2 - 50	80
S11706000	V1 - 5-21	76
S11708000	V1 - 106	78
S11709000	V1 - 104-1	78
S11711000	V2 - 61	80
S11712000	V2 - 59	80
S11714400	V2 - 115	82
S11715200	V2 - 57	80
S11716000	V1 - 62	76
S11717000	V1 - 71	78
S11728000	V1 - 150	78
S11731000	V2 - 63	80
S11732000	V2 - 70	80
S11748000	V1 - 5-11	76
S11749000	V1 - 5-8	76
S11750000	V1 - 5-9	76
S11751000	V1 - 5-10	76
S11752000	V1 - 5-7	76
S11753000	V1 - 5-6	76
S11754000	V1 - 5-5	76
S11755000	V1 - 5-4	76
S11756100	V1 - 5-3	76
S11757000	V1 - 5-13	76
S11761000	V1 - 5-20	76

CODE	REF.NO.	PAGE
S11762000	V2 - 87	80
S11763000	V2 - 86	80
S11803001	V1 - 25	76
S11811000	V1 - 1-1	76
S11816000	G - 53	24
	V1 - 151	78
S11817000	V1 - 83	78
S11826000	V1 - 5-1	76
S11827000	V1 - 5-2	76
S11828000	V2 - 122-1	82
S11830400	V2 - 115-1	82
S11831300	V2 - 115-2	82
S11837300	X - 4	88
S11839000	V2 - 89	80
S11840000	V2 - 75	80
S11841000	V2 - 76	80
S11842000	V2 - 77	80
S11848000	N1 - 18	58
	V1 - 80	78
S11854009	A - 2	2
S11855001	A - 13	2
S11856001	A - 15	2
S11857000	A - 17	2
	AC- 28	104
S11858001	A - 19	2
S11860009	A - 28	2
S11863001	B - 6	4
S11864009	AC- 4	104
	B - 20	4
S11864010	AC- 4	104
	B - 20	4
S11864012	AC- 4	104
	B - 20	4
S11864014	AC- 4	104
	B - 20	4
S11865001	B - 26	4
S11866000	B - 28	4
S11867001	B - 29	4
S11871101	D - 10	8
S11872001	D - 11	8
S11873001	D - 20	8
S11874001	D - 22	8
S11875001	D - 24	8
S11876001	D - 25	8
S11877001	D - 27	8
S11878000	D - 29	8
S11879000	D - 29-1	8
S11880000	D - 30	8
	K1 - 47	52
	K2 - 40	54
S11881001	D - 31	8
S11882009	D - 33	8
S11883001	D - 39	8
S11884001	M - 1	58
S11885001	M - 4	58
S11886000	M - 7	58
S11887101	H1 - 1	26
S11888001	H1 - 2	26
S11889001	AC- 10-1	104
	H1 - 6	26
S11890001	H1 - 9	26
S11891001	L - 1	56
S11892001	L - 3	56
S11893001	L - 9	56
S11894001	L - 12	56
S11896001	L - 15	56
S11898000	L - 18	56

CODE	REF.NO.	PAGE
S11899000	L - 19	56
S11900001	L - 31	56
S11901100	N2- 30	60
S11902000	N2- 32	60
S11903000	N2- 39	60
S11906000	N2- 40	60
S11907009	N2- 44	60
S11908000	N2- 46	60
S11909000	N2- 49	60
	N2- 80	60
S11910000	N2- 50	60
S11911009	N2- 55	60
S11912001	N2- 59	60
S11913001	N2- 63	60
S11914000	N2- 84	60
S11915000	N2- 72	60
S11916001	N2- 73	60
S11917001	N2- 76	60
S11918000	N2- 79	60
S11919000	N2- 81	60
S11920001	N2- 85	60
S11921000	B - 2	4
	L - 4	56
S11922000	B - 3	4
S11923000	L - 5	56
S11924000	L - 28	56
S11925109	P - 12	62
S11926001	R - 12	66
S11927009	R - 36	66
S11928009	R - 36-1	66
S11929001	R - 45	66
S11930001	R - 46	66
S11931001	S - 2	68
S11932001	S - 4	68
S11933001	S - 7	68
S11935009	Y - 4	88
S11936101	Y - 7	88
S11937001	Y - 9	88
S11944000	N2- 88	60
S11945000	N2- 53	60
S11946000	N1- 2	58
S11947000	N1- 3	58
S11951001	V2- 103-5	82
S11952000	U2- 78-1-1	74
S11953000	U2- 78-1	74
S11956000	U2- 78-5	74
S11957000	U2- 78-6	74
S11958000	U2- 78-7	74
S11959001	AC- 24	102
S11966001	C - 9	6
S11967001	C - 10	6
S11968009	E1 - 1	10
S11969000	E1 - 5	10
S11970009	E1 - 8	10
S11971009	E1 - 11	10
S11972001	E1 - 13	10
S11973000	E1 - 14	10
S11974000	E1 - 14-1	10
S11975000	E1 - 15	10
S11976000	E1 - 17	10
S11977001	E1 - 18	10
S11978009	E1 - 20	10
S11979000	E1 - 21	10
S11980001	E1 - 22	10
S11985001	E1 - 34	10
S11986000	E1 - 38	10
S11987000	E1 - 38-1	10

CODE	REF.NO.	PAGE
S11988000	E1 - 38-2	10
	K2 - 39-3	54
S11989009	E1 - 39	10
S11990001	E1 - 42	10
S11991001	E2 - 43	12
S11992000	E2 - 47	12
S11993000	E2 - 47-1	12
S11994000	E2 - 47-2	12
	E3 - 128-17-3	16
	K2 - 36-3	54
	K2 - 37-3	54
S11995009	E2 - 48	12
S11996000	E2 - 52	12
S11997001	E2 - 55	12
S11998009	E2 - 56	12
S12000009	E2 - 66	14
S12002000	E2 - 73	12
S12003000	E2 - 74	12
S12004000	E2 - 75	12
S12005001	E2 - 76	12
S12006000	E2 - 78	12
S12007000	E2 - 79	12
S12008000	E2 - 81	12
S12009000	E2 - 81-1	12
S12010000	E2 - 84	12
S12011001	E2 - 85	12
S12012000	E2 - 87-1	14
S12013000	E2 - 89-1	14
S12014000	E2 - 90	12
S12015000	E2 - 91	12
S12019001	E2 - 96	12
S12020001	E2 - 99	12
S12021001	E2 - 102	12
S12022001	E2 - 105	12
S12023001	E2 - 106	12
S12024000	E2 - 107	12
S12025000	E2 - 107-1	14
S12027109	Q - 1-1	64
S12029109	E2 - 112	14
S12030000	E2 - 115	14
S12031000	E2 - 115-1	14
S12033009	E2 - 118	14
S12035000	F - 2	20
S12036000	F - 3	20
S12038001	F - 53	20
	F - 9	20
S12039001	F - 10	20
	F - 46	20
S12043000	N1- 1	58
S12044000	F - 17	20
S12045000	F - 18	20
S12050001	F - 26	20
S12051000	F - 29	20
	K1 - 56	52
S12052000	F - 29-1	20
	K1 - 56-1	52
	K2 - 27-1	54
	K2 - 33-1	54
S12053000	F - 30	20
	K1 - 57	52
	K2 - 28	54
	K2 - 34	54
S12054000	F - 33	20
	F - 55	20
S12056001	F - 43	20
S12057200	E3 - 129	18
	X - 4	88

CODE	REF.NO.	PAGE
S12059009	F - 61	22
S12060001	F - 64	22
	F - 69	22
S12061009	F - 66	22
S12062009	F - 75	22
S12063009	G - 1	24
S12065000	G - 5	24
S12066000	G - 6	24
S12067000	G - 7	24
S12068001	G - 8	24
S12069000	G - 9	24
S12070000	G - 11	24
S12074000	G - 19	24
S12075002	G - 21	24
S12076000	G - 22	24
S12077000	G - 23	24
S12078000	E3 - 128-7	16
	G - 24	24
S12079000	G - 25	24
S12081000	G - 27	24
S12082000	G - 32	24
S12088009	J1 - 1-1-9	28
	J2 - 2-1-9	34
	J3 - 3-1-9	40
	J4 - 4-1-9	46
S12089009	J1 - 1-1-10	28
	J2 - 2-1-10	34
	J3 - 3-1-10	40
	J4 - 4-1-10	46
S12090000	J1 - 1-1-13	28
	J2 - 2-1-13	34
	J3 - 3-1-13	40
	J4 - 4-1-13	46
S12091000	J1 - 1-1-13-1	28
	J2 - 2-1-13-1	34
	J3 - 3-1-13-1	40
	J4 - 4-1-13-1	46
S12092000	J1 - 1-1-14	28
	J2 - 2-1-14	34
	J3 - 3-1-14	40
	J4 - 4-1-14	46
S12093001	J1 - 1-1-16	28
	J2 - 2-1-16	34
	J3 - 3-1-16	40
	J4 - 4-1-16	46
S12094001	J1 - 1-1-17	28
	J2 - 2-1-17	34
	J3 - 3-1-17	40
	J4 - 4-1-17	46
S12095001	J1 - 1-1-18	28
	J2 - 2-1-18	34
	J3 - 3-1-18	40
	J4 - 4-1-18	46
S12096001	J1 - 1-1-19	28
	J2 - 2-1-19	34
	J3 - 3-1-19	40
	J4 - 4-1-19	46
S12097001	J1 - 1-1-21	28
	J2 - 2-1-21	34
	J3 - 3-1-21	40
	J4 - 4-1-21	46
S12098001	J1 - 1-1-22	28
	J2 - 2-1-22	34
	J3 - 3-1-22	40
	J4 - 4-1-22	46
S12099001	J1 - 1-1-24	28
	J2 - 2-1-24	34

CODE	REF.NO.	PAGE
S12099001	J3 - 3-1-24	40
	J4 - 4-1-24	46
S12102000	J1 - 1-1-39	28
	J2 - 2-1-39	34
	J3 - 3-1-39	40
	J4 - 4-1-38	46
S12103000	J1 - 1-1-39-1	28
	J2 - 2-1-39-1	34
	J3 - 3-1-39-1	40
	J4 - 4-1-38-1	46
S12104000	E3 - 128-57	18
	J1 - 1-1-44	28
	J2 - 2-1-44	34
	J3 - 3-1-44	40
	J4 - 4-1-43	46
	U1 - 63	72
S12105100	J1 - 1-2-10	30
	J2 - 2-2-10	36
	J3 - 3-2-10	42
	J4 - 4-2-10	48
S12106000	J1 - 1-1-31	28
	J2 - 2-1-31	34
	J3 - 3-1-31	40
	J4 - 4-1-31	46
S12107001	J1 - 1-2-1	30
	J2 - 2-2-1	36
	J3 - 3-2-1	42
	J4 - 4-2-1	48
S12108001	J1 - 1-2-6	30
	J2 - 2-2-6	36
	J3 - 3-2-6	42
	J4 - 4-2-6	48
S12109100	J1 - 1-2-7	30
	J2 - 2-2-7	36
	J3 - 3-2-7	42
	J4 - 4-2-7	48
S12110001	J1 - 1-3-1	30
	J2 - 2-3-1	36
	J3 - 3-3-1	42
	J4 - 4-3-1	48
S12111001	J1 - 1-5	30
	J2 - 2-5	36
	J3 - 3-5	42
	J4 - 4-5	48
S12112001	J1 - 1-6	30
	J2 - 2-6	36
	J3 - 3-6	42
	J4 - 4-6	48
S12113001	J1 - 1-4-1	30
	J2 - 2-4-1	36
	J3 - 3-4-1	42
	J4 - 4-4-1	48
S12114001	J1 - 1-4-5	30
	J2 - 2-4-5	36
	J3 - 3-4-5	42
	J4 - 4-4-5	48
S12116000	AC - 20	102
S12117000	AC - 21	102
	J1 - 1-4-14	30
	J2 - 2-4-15	36
	J3 - 3-4-15	42
	J4 - 4-4-14	48
S12119001	K1 - 2	52
S12123000	K1 - 8	52
S12125000	K1 - 14	52
S12126000	K1 - 14-1	52
S12127109	K1 - 15	52

CODE	REF.NO.	PAGE
S12128101	K1 - 16	52
S12129000	K1 - 18	52
S12130000	K1 - 21	52
S12131000	K1 - 22	52
S12132009	K2 - 23	54
S12133000	K2 - 24	54
S12134001	K2 - 25	54
S12135000	K2 - 27	54
	K2 - 33	54
S12136009	K2 - 30	54
S12137009	K2 - 31	54
S12138000	K2 - 36	54
S12139000	E3 - 128-17-2	16
	K2 - 36-2	54
	K2 - 37-2	54
S12140000	K2 - 36-1	54
S12141000	K2 - 37	54
S12142000	K2 - 37-1	54
S12144100	K2 - 39	54
S12145000	K2 - 39-2	54
S12146000	K2 - 39-1	54
S12150000	E2 - 81-2	12
	K1 - 43-2	52
	U1 - 88-3	72
S12151009	K1 - 48	52
S12152001	K1 - 49	52
S12153001	K1 - 50	52
S12154000	K1 - 53	52
S12155101	U1 - 1-1	70
S12158000	U1 - 1-2-2	70
S12159000	U1 - 1-2-5	70
S12160000	U1 - 1-2-3	70
	U1 - 7-2	70
S12161000	U1 - 1-2-4	70
	U1 - 1-3-2	70
	U1 - 7-3	70
	U2 - 10-1	74
S12164000	U1 - 1-3-3	70
S12165000	U1 - 1-6	70
S12166000	U1 - 14	70
S12167000	U1 - 24	70
S12168000	U1 - 18	70
S12169000	U1 - 18-1	70
S12170000	U1 - 18-3	70
S12171001	U1 - 19	70
S12172000	U1 - 20	70
S12173000	U1 - 24-1	70
S12174000	U1 - 24-3	70
S12175000	U1 - 29	70
	U2 - 79-10	74
S12176000	U1 - 32	70
S12178000	U1 - 36	72
S12179000	U1 - 37	72
S12181000	U1 - 39	72
S12182000	U1 - 40	72
S12183000	E3 - 128-56	18
	U1 - 41	72
S12184000	U1 - 42	72
S12185000	U1 - 43	72
S12186000	U1 - 44	72
S12187000	U1 - 45	72
S12188000	U1 - 46	72
S12189000	U1 - 47	72
S12190000	U1 - 48	72
S12191000	U1 - 49	72
	U1 - 57	72
	U1 - 94	72

CODE	REF.NO.	PAGE
S12191000	U2 - 79-13	74
S12192000	U1 - 50	72
S12193000	U1 - 51	72
	U1 - 95	72
S12194000	U1 - 52	72
S12195000	E3 - 128-55	18
	U1 - 53	72
S12196000	U1 - 54	72
	U1 - 96	72
S12197000	U1 - 55	72
	U1 - 97	72
S12198000	U1 - 56	72
S12201000	U1 - 59	72
S12205000	J1 - 1-1-43	28
	J2 - 2-1-43	34
	J3 - 3-1-43	40
	J4 - 4-1-42	46
S12206000	U1 - 66	72
	U2 - 78-8	74
	U2 - 79-11	74
S12207000	U1 - 67	72
	U2 - 78-10	74
	U2 - 79-15	74
S12208000	U1 - 68	72
S12209000	U1 - 69	72
	U2 - 79-4	74
S12210000	U1 - 70	72
	U2 - 79-16	74
S12211000	U1 - 72	72
S12212000	U1 - 73	72
	V2 - 85	80
S12213000	U1 - 74	72
S12214000	J1 - 1-1-30	28
	J2 - 2-1-30	34
	J3 - 3-1-30	40
	J4 - 4-1-30	46
	U1 - 75	72
	V2 - 110	82
S12215000	U1 - 76	72
	V2 - 84	80
S12216001	W1 - 1	84
S12217001	W1 - 4	84
S12219001	W1 - 10	84
S12222009	T - 1	68
S12225000	Z1 - 3	90
	Z2 - 3	94
S12230001	Z1 - 10	90
	Z2 - 10	94
S12235009	Z1 - 23	90
	Z2 - 23	94
S12236109	Z1 - 26	90
	Z2 - 26	94
S12239009	Z1 - 35	90
	Z2 - 35	94
S12243001	Z1 - 46	90
	Z2 - 46	94
S12244101	Z1 - 47	90
S12246001	Z1 - 51	90
	Z2 - 51	94
S12247001	Z1 - 52	90
	Z2 - 52	94
S12249000	Z1 - 58	90
	Z2 - 58	94
S12250009	Z1 - 59	90
	Z2 - 59	94
S12260009	Z1 - 78	92
	Z2 - 78	94

CODE	REF.NO.	PAGE
S12268000	F - 58	20
S12269000	F - 59	20
S12270000	F - 60	20
S12271000	K2 - 38	54
S12272001	AB- 2	100
S12273001	AB- 3	100
S12274001	AB- 4	100
S12276000	E2 - 116	14
S12278000	J1 - 1-2-11	30
	J2 - 2-2-11	36
	J3 - 3-2-11	42
	J4 - 4-2-11	48
S12279000	J1 - 1-3-7	30
	J2 - 2-3-7	36
	J3 - 3-3-7	42
	J4 - 4-3-7	48
S12280100	Z1 - 90	92
S12281001	AB- 5	100
S12283---	J1 - 1	28
S12283001	AB- 2-1	100
	AB- 7-1	100
S12284---	J1 - 1-1	28
S12285---	J1 - 1-1-32	28
S12286---	J1 - 1-1-33	28
S12287---	J1 - 1-1-34	28
S12288---	J1 - 1-1-35	28
S12289---	J1 - 1-1-45	28
S12291001	J1 - 1-1-47	28
	J2 - 2-1-49	34
	J3 - 3-1-49	40
	J4 - 4-1-54	46
S12292---	J1 - 1-2	30
S12293---	J1 - 1-2-9	30
S12294001	J1 - 1-1-48	28
	J2 - 2-1-50	34
	J3 - 3-1-50	40
	J4 - 4-1-55	46
S12295---	J1 - 1-3	30
S12296---	J1 - 1-3-5	30
S12297000	J1 - 1-1-46	28
	J2 - 2-1-46	34
	J3 - 3-1-55	40
	J4 - 4-1-45	46
S12298000	AC- 19	102
	J1 - 1-3-6	30
	J2 - 2-3-6	36
	J3 - 3-3-6	42
	J4 - 4-3-6	48
S12299---	J1 - 1-4	30
S12300---	J1 - 1-4-7	30
S12301---	J1 - 1-4-8	30
S12302---	J1 - 1-4-9	30
S12303---	J1 - 1-4-10	30
S12305---	J2 - 2	34
S12305001	AB- 3-1	100
	AB- 8-1	100
S12306---	J2 - 2-1	34
S12307---	J2 - 2-1-32	34
S12308---	J2 - 2-1-33	34
S12309---	J2 - 2-1-34	34
S12310---	J2 - 2-1-35	34
S12311---	J2 - 2-1-45	34
S12312---	J2 - 2-2	36
S12313---	J2 - 2-2-9	36
S12314---	J2 - 2-3	36
S12315---	J2 - 2-3-5	36
S12316---	J2 - 2-4	36

CODE	REF.NO.	PAGE
S12317---	J2 - 2-4-7	36
S12318---	J2 - 2-4-8	36
S12319---	J2 - 2-4-9	36
S12320---	J2 - 2-4-10	36
S12321---	J2 - 2-4-11	36
S12323---	J3 - 3	40
S12323001	AB- 4-1	100
	AB- 9-1	100
S12324---	J3 - 3-1	40
S12325---	J3 - 3-1-32	40
S12326---	J3 - 3-1-33	40
S12327---	J3 - 3-1-34	40
S12328---	J3 - 3-1-35	40
S12329---	J3 - 3-1-45	40
S12330---	J3 - 3-2	42
S12331---	J3 - 3-2-9	42
S12332---	J3 - 3-3	42
S12333---	J3 - 3-3-5	42
S12334---	J3 - 3-4	42
S12335---	J3 - 3-4-7	42
S12336---	J3 - 3-4-8	42
S12337---	J3 - 3-4-9	42
S12338---	J3 - 3-4-10	42
S12339---	J3 - 3-4-11	42
S12341---	J4 - 4	46
S12341001	AB- 10-1	100
	AB- 5-1	100
S12342---	J4 - 4-1	46
S12343---	J4 - 4-1-32	46
S12344---	J4 - 4-1-33	46
S12345---	J4 - 4-1-34	46
S12346---	J4 - 4-1-44	46
S12347---	J4 - 4-2	48
S12348---	J4 - 4-2-9	48
S12349---	J4 - 4-3	48
S12350---	J4 - 4-3-5	48
S12351---	J4 - 4-4	48
S12352---	J4 - 4-4-7	48
S12353---	J4 - 4-4-8	48
S12354---	J4 - 4-4-9	48
S12355---	J4 - 4-4-10	48
S12356001	Z1 - 95	92
	Z2 - 95	96
S12359001	Z1 - 48	90
S12458000	V2 - 60-1	80
S12459000	V2 - 60-2	80
S12461001	V2 - 122-2	82
S12463001	V2 - 122	82
S12465000	V2 - 103-2	82
S12466000	V2 - 102	82
	Z1 - 91	92
	Z2 - 91	96
S12467001	V2 - 103	82
S12469000	J4 - 4-1-48	46
S12470000	J4 - 4-1-51	46
S12471000	J4 - 4-1-52	46
S12475100	J1 - 1-1-26	28
	J2 - 2-1-26	34
	J3 - 3-1-26	40
	J4 - 4-1-26	46
S12476100	J1 - 1-1-27	28
	J2 - 2-1-27	34
	J3 - 3-1-27	40
	J4 - 4-1-27	46
S12481000	N1 - 17	58
	Z1 - 110	92
	Z2 - 110	96

CODE	REF.NO.	PAGE
S12482009	N1 - 16	58
S12483000	N1 - 7	58
S12484000	N1 - 8	58
S12485001	J1 - 1-4-15	30
	J2 - 2-4-16	36
	J3 - 3-4-16	42
	J4 - 4-4-15	48
S12487000	J1 - 1-4-20	30
	J2 - 2-4-21	36
	J3 - 3-4-21	42
	J4 - 4-4-20	48
S12488001	AB- 7	100
S12489001	AB- 8	100
S12490001	AB- 9	100
S12491001	AB- 10	100
S12494000	J1 - 5	30
	J2 - 5	36
	J3 - 5	42
	J4 - 5	50
S12495001	U2- 78	74
S12496001	U2- 79	74
S12497000	U2- 79-1	74
S12498000	U2- 79-1-1	74
S12499000	U2- 79-5	74
S12500001	U2- 79-6	74
S12501001	U2- 79-7	74
S12502000	U2- 79-12	74
S12506001	Z1 - 102	92
	Z2 - 102	96
S12509000	U2- 79-17	74
S12565009	V2 - 103-1	82
S13103009	D - 36	8
S13385001	D - 7	8
S14328000	J1 - 1-1-53-3	28
	J2 - 2-1-55-3	34
	J3 - 3-1-56-3	40
	J4 - 4-1-60-3	48
	U1 - 34	72
S14461009	E3 - 128	16
S14462009	E3 - 128-1	16
S14463009	E3 - 128-4	16
S14464001	E3 - 128-11	16
S14465009	E3 - 128-12	16
S14466001	E3 - 128-15	16
S14468000	E3 - 128-17	16
S14469000	E3 - 128-17-1	16
S14470000	E3 - 128-20	16
S14471000	E3 - 128-23	16
S14472000	E3 - 128-23-1	16
S14473000	E3 - 128-24	16
S14475009	E3 - 128-28	16
S14477000	E3 - 128-29	16
S14478001	E3 - 128-32	16
S14479001	E3 - 128-34	16
S14480000	E3 - 128-35	16
S14481009	E3 - 128-38	16
S14482009	E3 - 128-39	16
S14483009	E3 - 128-40	16
S14484009	E3 - 128-44	16
S14485009	E3 - 128-48	16
S14486009	E3 - 128-51	16
S15525001	K1 - 72	52
S15526001	K1 - 71	52
S15528001	Z1 - 106	92
	Z2 - 106	96
S15530001	K1 - 6	52
S15531001	K1 - 7	52

CODE	REF.NO.	PAGE
S15532009	K1 - 1	52
S15533009	Z1 - 32	90
	Z2 - 32	94
S15538001	F - 19	20
S15539001	F - 20	20
S15540000	F - 40	20
S15542109	K1 - 10	52
S15544001	U2- 86	74
S15545000	F - 82	22
S15547009	Z1 - 38	90
S15551001	F - 87	22
S15556009	K1 - 5	52
S15557009	Z1 - 63	90
	Z2 - 63	94
S15558009	Z1 - 109	92
	Z2 - 109	96
S15561000	U1- 88	72
S15562000	U1- 88-1	72
S15563000	J1 - 1-1-53-1	28
	J2 - 2-1-55-1	34
	J3 - 3-1-56-1	40
	J4 - 4-1-60-1	48
S15564000	J1 - 1-1-53	28
	J2 - 2-1-55	34
	J3 - 3-1-56	40
	J4 - 4-1-60	46
S15565100	J1 - 6	30
	J2 - 6	36
	J3 - 6	42
	J4 - 6	50
S15566100	J1 - 7	30
	J2 - 7	36
	J3 - 7	42
	J4 - 7	50
S15567000	K2 - 39-4	54
S15569001	W1- 7	84
S16170001	L - 23	56
S16513000	J1 - 1-10	30
	J2 - 2-10	36
	J3 - 3-10	42
	J4 - 4-10	50
S16514000	J1 - 1-9	30
	J2 - 2-9	36
	J3 - 3-9	42
	J4 - 4-9	50
S16515---	J4 - 4-1-61	48
S16516---	J4 - 4-1-62	48
S16517---	J4 - 4-1-63	48
S16558000	V1 - 1-7	76
S16661001	V2 - 72	80
S16667000	Q - 1-26-1	64
S16669000	Q - 1-34	64
S17029000	V1 - 1-5	76
S17701009	Q - 1	64
S17706001	F - 5	20
S17707009	E1 - 25	10
S17708009	Z1 - 55	90
	Z2 - 55	94
S17709001	W1- 18-3	84
	W2- 11	86
S17710001	W1- 18-1	84
S17711101	W1- 18-2	84
S17716009	F - 21	20
S17717009	F - 23	20
S17718000	E2 - 94	12
S17719009	F - 1	20
S17720009	Z1 - 64	90

CODE	REF.NO.	PAGE
S17720009	Z2 - 64	94
S17721009	Z1 - 114	92
	Z2 - 114	96
S17722009	Z1 - 113	92
	Z2 - 113	96
S17724001	F - 83	22
S17725000	F - 13	20
S17726000	F - 13-1	20
S17730001	U1- 1-2	70
S19063101	AC- 11	102
	D - 6	8
S19064001	AC- 11-1	102
	D - 6-1	8
S19065101	AC- 11-2	102
	D - 6-2	8
S19067000	U1- 1-2-1	70
S19068000	AC- 11-4	102
	D - 6-4	8
S19080000	A - 34	2
S19509000	V2- 111	82
S19510000	V2- 112	82
S19522001	Q - 1-26	64
S19523201	N1- 6	58
S19526000	U1- 7-1	70
S19527000	U1- 7	70
S19553000	F - 14	20
	F - 32	20
S19555000	J2 - 2-1-47	34
	J3 - 3-1-47	40
	J4 - 4-1-46	46
S19585000	U1- 89	72
S19675000	U2- 10	74
S19971000	U1- 92	72
S19972000	U1- 92-1	72
S20019001	V1 - 1	76
S20029000	V1- 1-12	76
S20038000	AC- 23	102
	V1 - 1-9	76
S20045000	V2- 14	80
S20047000	V2- 17	80
S20049000	V1 - 1-2	76
S20051000	V1 - 1-11	76
S20053000	V1 - 1-3	76
S20054000	V1 - 1-4	76
S20246001	J1 - 1-1-5	28
	J1 - 1-4-6	30
	J2 - 2-1-5	34
	J2 - 2-4-6	36
	J3 - 3-1-5	40
	J3 - 3-4-6	42
	J4 - 4-1-5	46
	J4 - 4-4-6	48
	W1- 18-9	84
	W2- 17	86
S20551000	V2- 18	80
S20552000	V2- 22	80
S20789000	E2 - 93-1	14
S20816001	D - 42	8
S20850001	Z1 - 29	90
	Z2 - 29	94
S20851000	Z1 - 115	92
	Z2 - 115	96
S21083001	V1 - 26	76
S21121001	J1 - 8	30
	J2 - 8	36
	J3 - 8	42
	J4 - 8	50

CODE	REF.NO.	PAGE
S21122001	J1 - 9	30
	J2 - 9	38
	J3 - 9	44
	J4 - 9	50
S21123001	J1 - 10	30
	J2 - 10	38
	J3 - 10	44
	J4 - 10	50
S21186101	X - 2	88
S23328000	V1 - 138	78
S23329000	V1 - 139	78
S23392001	E2 - 70	14
S23394000	E2 - 125	14
S23395001	E2 - 120	14
S23396000	K1 - 43	52
S23397000	K1 - 43-1	52
S23398001	E2 - 110	14
S23399001	W1- 21	84
	W2- 4	86
S23400001	W1- 22	84
	W2- 5	86
S23401001	W1- 23	84
S23402001	W1- 27	84
	Z2 - 47	94
S23403001	G - 13	24
S23404001	G - 14	24
S23763009	Z1 - 66	90
	Z2 - 66	94
S23836001	R - 40	66
S23868000	V1 - 8	76
S23869200	V1 - 154	78
S23871001	X - 1	88
S24454001	J1 - 11-1	32
	J2 - 11-1	38
	J3 - 11-1	44
	J4 - 11-1	50
S24455001	J1 - 11-2	32
	J2 - 11-2	38
	J3 - 11-2	44
	J4 - 11-2	50
S24456001	J1 - 12-1	32
	J2 - 12-1	38
	J3 - 12-1	44
	J4 - 12-1	50
S24457001	J1 - 12-2	32
	J2 - 12-2	38
	J3 - 12-2	44
	J4 - 12-2	50
S24458001	J1 - 1-1-55-1	30
	J2 - 2-1-57-1	36
	J3 - 3-1-58-1	42
	J4 - 4-1-66-1	48
S24459001	J1 - 1-1-55-2	30
	J2 - 2-1-57-2	36
	J3 - 3-1-58-2	42
	J4 - 4-1-66-2	48
S24460001	J1 - 1-1-54-1	28
	J2 - 2-1-56-1	36
	J3 - 3-1-57-1	42
	J4 - 4-1-65-1	48
S24461001	J1 - 1-1-54-2	30
	J2 - 2-1-56-2	36
	J3 - 3-1-57-2	42
	J4 - 4-1-65-2	48
S24541000	C - 18	6
S24545001	C - 23	6
S24546001	C - 24	6

CODE	REF.NO.	PAGE
S24547001	C - 25	6
S24548001	C - 27	6
S24549000	C - 28	6
S24550000	C - 29	6
S24551000	C - 34	6
S24552001	H2- 1	26
S24553001	AC- 10-2	104
	H2- 2	26
S24554000	E1 - 24	10
S24555000	E2 - 89-2	14
S24556000	E2 - 87-2	14
S24558001	Z2 - 120	96
S24559001	Z2 - 121	96
S24560001	E2 - 59	12
S24561000	C - 31	6
S24564009	Z1 - 42	90
	Z2 - 42	94
S24566000	E2 - 93-2	14
S24567000	E1 - 33	10
S24568000	Z2 - 124	96
S24733001	C - 1	6
S24734001	C - 2	6
S24735001	C - 4-2	6
S24760009	E2 - 63	12
S24767001	G - 17	24
S24768000	G - 26	24
S24769001	G - 35	24
S24770001	G - 46	24
S24773001	AC- 30	104
S24774001	Z1 - 14	90
	Z2 - 14	94
S24775001	Z1 - 17	90
	Z2 - 17	94
S24776001	C - 3	6
S24777000	Z1 - 2	90
	Z2 - 2	94
S24828000	J1 - 13	32
	J2 - 13	38
	J3 - 13	44
	J4 - 13	50
S24830001	G - 38	24
S24831001	G - 39	24
S24832001	F - 49	20
S24886001	J1 - 12	32
	J2 - 12	38
	J3 - 12	44
	J4 - 12	50
S24887001	J1 - 11	32
	J2 - 11	38
	J3 - 11	44
	J4 - 11	50
S24888001	J1 - 1-1-54	28
	J2 - 2-1-56	34
	J3 - 3-1-57	40
	J4 - 4-1-65	48
S24889001	J1 - 1-1-55	30
	J2 - 2-1-57	36
	J3 - 3-1-58	42
	J4 - 4-1-66	48
S24891000	J1 - 14	32
	J2 - 14	38
	J3 - 14	44
	J4 - 14	50
S24892000	J1 - 15	32
	J2 - 15	38
	J3 - 15	44
	J4 - 15	50

CODE	REF.NO.	PAGE
S24897000	C - 13	6
S24902001	L - 14	56
S24939000	U1 - 1-3	70
S24940000	U1 - 1-3-1	70
S24953000	U1 - 90	72
S24964000	Y - 12	88
S24965000	Y - 12-1	88
S24966000	Y - 12-2	88
S24969009	Z1 - 60	90
	Z2 - 60	94
S24970009	Z1 - 61	90
	Z2 - 61	94
S24971009	Z1 - 65	90
	Z2 - 65	94
S24972009	Z1 - 71	90
	Z2 - 71	94
S24973009	Z1 - 72	90
	Z2 - 72	94
S24974009	Z1 - 75	90
	Z2 - 75	94
S24975001	Z1 - 82	92
	Z2 - 82	94
S24976001	Z1 - 83	92
	Z2 - 83	96
S24977001	Z1 - 85	92
	Z2 - 85	96
S24979001	Z1 - 88	92
	Z2 - 88	96
S25059000	C - 19	6
S25060000	C - 20	6
S25061000	K2 - 37-1	54
S25062000	K2 - 37	54
S25063000	K2 - 36-1	54
S25064000	K2 - 36	54
S25065000	K2 - 39-1	54
S25066000	K2 - 39	54
S25067001	K2 - 82	54
S25068001	K2 - 81	54
S25069001	K2 - 87	54
S25070009	K2 - 85	54
S25071009	K2 - 86	54
S25072001	W2- 6	86
S25073001	W2- 1	86
S25074001	W2- 10	86
S25075001	Z1 - 81	92
	Z2 - 81	94
S25076001	Z1 - 86	92
	Z2 - 86	96
S25077009	AC- 4	104
	B - 20	4
S25077010	AC- 4	104
	B - 20	4
S25077012	AC- 4	104
	B - 20	4
S25205000	V1 - 65	76
S25206000	V1 - 33	76
S25207000	V1 - 34	76
S25208000	V1 - 27	76
S25209000	V2 - 29	80
S25210000	V2 - 30	80
S25518101	X - 4	88
S25575000	V2 - 31	80
S25576000	V2 - 42	80
S25577000	V2 - 43	80
S25578000	V2 - 44	80
S25579100	V2 - 39	80
S25580100	V2 - 40	80

CODE	REF.NO.	PAGE
S25581100	V2 - 41	80
S25582000	V1 - 28	76
S25583000	V1 - 46	76
S25584000	V1 - 104	78
S25585000	V1 - 10	76
S25868100	V2 - 109	82
S27932009	Z1 - 62	90
	Z2 - 62	94
S27937000	W1- 14	84
	W1- 18-4	84
	W2- 12	86
S27938000	W1- 14-1	84
	W1- 18-4-1	84
	W2- 12-1	86
S29166001	U1- 1	70
S29240000	U1- 92-2	72
S29880001	B - 1	4
S29881009	Y - 11	88
S29883009	Y - 1	88
S29992000	X - 3	88
S30105009	V1 - 5	76
S30107009	V1 - 6	78
S30109009	V1 - 6	78
S30171009	V1 - 6	78
S30173009	V1 - 6	78
S30514001	W1- 18	84
S31176001	C - 4-1	6
U42775001	AB- 10-2	100
	AB- 2-2	100
	AB- 3-2	100
	AB- 4-2	100
	AB- 5-2	100
	AB- 7-2	100
	AB- 8-2	100
	AB- 9-2	100
	AC- 18	102
002300803	V1 - 5-17	76
004300513	Q - 1-2	64
004400702	E1 - 32	10
	Z1 - 89	92
	Z2 - 89	96
004400804	E2 - 126	14
	E3 - 128-36	16
	Z1 - 70	90
	Z2 - 70	94
004401414	U2- 79-8	74
008400604	E2 - 113	14
	E2 - 119	14
	F - 24	20
	G - 52	24
	Z1 - 112	92
	Z1 - 18	90
	Z1 - 56	90
	Z1 - 68	90
	Z2 - 112	96
	Z2 - 18	94
	Z2 - 56	94
	Z2 - 68	94
008400806	N1- 14	58
	Z1 - 111	92
	Z2 - 111	96
013680512	C - 32	6
013781012	B - 13	4
014060632	E1 - 41	10
	E2 - 58	12
	G - 10	24
	G - 12	24

CODE	REF.NO.	PAGE
014060632	G - 20	24
	K1 - 73	52
	K2 - 26	54
	K2 - 32	54
	Z1 - 41	90
014300332	Q - 1-5	64
014400422	A - 16	2
	B - 4	4
	D - 40	8
	Y - 10	88
014400522	E1 - 12	10
	E2 - 77	12
	E2 - 80	12
	F - 74	22
	G - 44	24
	J1 - 1-1-20	28
	J2 - 2-1-20	34
	J3 - 3-1-20	40
	J4 - 4-1-20	46
	P - 2	62
	U1 - 33	72
014400822	L - 16	56
	L - 29	56
	L - 6	56
	P - 20	62
	R - 25	66
	R - 47	66
014500522	A - 22	2
	A - 25	2
	D - 28	8
	E2 - 88-1	14
	E2 - 88-2	14
	E2 - 92	12
	E2 - 97	12
	E3 - 128-33	16
	F - 65	22
	F - 70	22
	H1 - 3	26
	J1 - 1-2-5	30
	J1 - 1-4-4	30
	J2 - 2-2-5	36
	J2 - 2-4-4	36
	J3 - 3-2-5	42
	J3 - 3-4-4	42
	J4 - 4-2-5	48
	J4 - 4-4-4	48
	K1 - 17	52
	Y - 11-1	88
014680422	Q - 1-8	64
014680622	R - 40-1	66
014710522	D - 36-1	8
014770622	B - 27	4
	D - 23	8
	L - 13	56
	L - 2	56
	L - 32	56
014771022	B - 11	4
	R - 3	66
018060822	U1 - 2	70
018061022	U1 - 15	70
018061422	E1 - 9	10
	E2 - 44	12
	E2 - 53	12
018062022	E2 - 49	12
	E2 - 67	12
	G - 2	24
	G - 28	24

CODE	REF.NO.	PAGE	
018062022	K1 - 63	52	
	K1 - 74	52	
018062522	E1 - 19	10	
	E1 - 40	10	
	E2 - 57	12	
	G - 15	24	
	K1 - 65	52	
018063022	G - 31	24	
018081222	E1 - 35	10	
	E1 - 6	10	
018081422	Z1 - 44	90	
	Z2 - 44	94	
018081622	K1 - 11	52	
018082022	U2- 78-2	74	
	F - 62	22	
	F - 67	22	
	F - 76	22	
	V2 - 15	80	
	Z1 - 33	90	
	Z1 - 36	90	
	Z1 - 39	90	
	Z1 - 79	92	
	Z2 - 33	94	
	Z2 - 36	94	
	Z2 - 79	94	
	018082522	E1 - 2	10
		K1 - 4	52
018300532	J1 - 1-4-11	30	
	J1 - 1-4-21	30	
	J2 - 2-4-12	36	
	J2 - 2-4-22	36	
	J3 - 3-4-12	42	
	J3 - 3-4-22	42	
	J4 - 4-4-11	48	
	J4 - 4-4-21	48	
018300822	V1 - 161	78	
018400632	J1 - 1-1-28	28	
	J1 - 1-1-36	28	
	J2 - 2-1-28	34	
	J2 - 2-1-36	34	
	J3 - 3-1-28	40	
	J3 - 3-1-36	40	
	J4 - 4-1-28	46	
	J4 - 4-1-35	46	
	018400822	K1 - 51	52
		S - 13	68
		V1 - 2	76
		V2 - 36	80
		Z1 - 30	90
		Z2 - 30	94
018400832	E3 - 128-41	16	
	E3 - 128-8	16	
	F - 50	20	
	F - 6	20	
	F - 85	22	
	G - 36	24	
	G - 40	24	
	J4 - 4-1-49	46	
	K1 - 19	52	
	N1 - 20	58	
	U1 - 1-8	70	
	V2 - 103-3	82	
	V2 - 94	80	
	Z1 - 12	90	
	Z1 - 15	90	
	Z1 - 24	90	
	Z2 - 12	94	

CODE	REF.NO.	PAGE	
018400832	Z2 - 15	94	
	Z2 - 24	94	
018401022	E2 - 108	14	
	E2 - 86	12	
	E3 - 128-2	16	
	J1 - 1-3-2	30	
	J2 - 2-3-2	36	
	J3 - 3-3-2	42	
	J4 - 4-3-2	48	
	Y - 8	88	
	Z1 - 107	92	
	Z2 - 107	96	
	018401222	E2 - 71	14
		J1 - 1-1-11	28
		J2 - 2-1-11	34
J3 - 3-1-11		40	
J4 - 4-1-11		46	
L - 22		56	
V1 - 107		78	
018401622		E2 - 100	12
		E2 - 103	12
		E2 - 82	12
		E3 - 128-37	16
	F - 41	20	
	G - 33	24	
	N2 - 65	60	
	U1 - 25	70	
	Z1 - 73	90	
	Z2 - 73	94	
018402032	J1 - 1-2-3	30	
	J2 - 2-2-3	36	
	J3 - 3-2-3	42	
	J4 - 4-2-3	48	
	018402522	E3 - 128-58	18
018403022		U1 - 64	72
018500822		E3 - 128-18	16
018501022	E3 - 128-21	16	
	H1 - 10	26	
	E1 - 27	10	
	E2 - 123	14	
	E3 - 128-45	16	
	E3 - 128-49	16	
	E3 - 128-52	16	
	018501222	C - 6	6
		E2 - 64	12
		K1 - 45	52
K2 - 41		54	
Z1 - 76		90	
Z2 - 122		96	
Z2 - 76		94	
018501622		A - 20	2
		E2 - 111	14
		E3 - 128-26	16
	E3 - 128-5	16	
	F - 11	20	
	F - 47	20	
	G - 42	24	
	K2 - 83	54	
	U2 - 79-2	74	
	V2 - 19	80	
	W1 - 2	84	
	W1 - 24	84	
	W1 - 8	84	
	W2 - 2	86	
W2 - 7	86		
018502022	E2 - 121	14	
	E3 - 128-13	16	

CODE	REF.NO.	PAGE	
018502022	E3 - 128-16	16	
	F - 27	20	
	F - 44	20	
	J1 - 1-1-54-3	30	
	J1 - 1-1-55-3	30	
	J1 - 11-3	32	
	J1 - 12-3	32	
	J2 - 11-3	38	
	J2 - 12-3	38	
	J2 - 2-1-56-3	36	
	J2 - 2-1-57-3	36	
	J3 - 11-3	44	
	J3 - 12-3	44	
	J3 - 3-1-57-3	42	
	J3 - 3-1-58-3	42	
	J4 - 11-3	50	
	J4 - 12-3	50	
	J4 - 4-1-65-3	48	
	J4 - 4-1-66-3	48	
	K2 - 88	54	
	W1- 11	84	
	W1- 15	84	
	W1- 18-5	84	
	W1- 26	84	
	W1- 5	84	
	W2- 13	86	
	W2- 9	86	
	Z1 - 94	92	
	Z1 - 27	90	
	Z2 - 27	94	
	018502222	Z1 - 27	90
		Z2 - 27	94
	018502522	F - 54	20
		J1 - 1-1-3	28
		J1 - 1-4-2	30
		J2 - 2-1-3	34
		J2 - 2-4-2	36
		J3 - 3-1-3	40
		J3 - 3-4-2	42
		J4 - 4-1-3	46
		J4 - 4-4-2	48
W1- 18-7		84	
W2- 15		86	
Z1 - 53		90	
Z2 - 53		94	
018503022		U1 - 1-4	70
		U1 - 8	70
		W1- 18-6	84
W2- 14		86	
021060206		J1 - 1-1-52	28
		J2 - 2-1-54	34
		J3 - 3-1-54	40
		J4 - 4-1-59	46
021080302	U2 - 78-9	74	
021200203	Z1 - 96	92	
	Z2 - 96	96	
021400103	J1 - 1-4-18	30	
	J2 - 2-4-19	36	
	J3 - 3-4-19	42	
	J4 - 4-4-18	48	
	K1 - 55	52	
021400202	N2 - 66	60	
	Q - 1-25	64	
021500106	AC- 25-1	102	
	AC- 6-4-2	102	
	AC- 6-7-3	102	
025030132	V2 - 125	82	
025030133	V1 - 5-18	76	
	V1 - 68	76	

CODE	REF.NO.	PAGE	
025030232	J1 - 1-4-13	30	
	J2 - 2-4-14	36	
	J3 - 3-4-14	42	
	J4 - 4-4-13	48	
025030233	Q - 1-29	64	
	V1 - 69	78	
025040132	J4 - 4-1-64	48	
025040232	E3 - 128-10	16	
	F - 52	20	
	F - 57	20	
	F - 8	20	
	F - 88	22	
	Q - 1-22	64	
	S - 14	68	
	V1 - 4	76	
	V2 - 38	80	
	Z1 - 74	90	
	Z2 - 74	94	
	025040233	A - 38	2
		E2 - 61	12
		E3 - 128-43	16
		E3 - 128-62	18
		F - 35	20
		F - 38	20
		G - 51	24
		J1 - 1-1-8	28
		J2 - 2-1-8	34
		J3 - 3-1-8	40
J4 - 4-1-8		46	
K1 - 61		52	
N1 - 22		58	
V1 - 100		78	
V1 - 13		76	
V1 - 153		78	
V1 - 56		76	
V2 - 93		80	
V2 - 21		80	
025050132		V2 - 21	80
		C - 8	6
025050232	E1 - 29	10	
	E3 - 128-47	16	
	E3 - 128-54	16	
	W1- 12	84	
	W1- 16	84	
	E2 - 46	12	
	E2 - 51	12	
	E2 - 69	12	
	G - 29	24	
	K1 - 67	52	
025060232	K1 - 75	52	
	U1 - 98	72	
	E1 - 37	10	
	E1 - 4	10	
	K1 - 78	52	
	U2 - 78-4	74	
	Z1 - 105	92	
	Z2 - 105	96	
	D - 44	8	
	025080232	J1 - 1-4-12	30
J1 - 1-8		30	
J2 - 2-4-13		36	
J2 - 2-8		36	
J3 - 3-4-13		42	
J3 - 3-8		42	
J4 - 4-4-12		48	
J4 - 4-8		50	
M - 3		58	
M - 6		58	
025350132	J1 - 1-4-12	30	
	J1 - 1-8	30	
028030242	J2 - 2-4-13	36	
	J2 - 2-8	36	

CODE	REF.NO.	PAGE
028030242	U2 - 79-14	74
	V1 - 162	78
	V2 - 122-4	82
	V2 - 124	82
	Y - 6	88
028030243	F - 31	20
	H1 - 8	26
	J1 - 1-1-15	28
	J2 - 2-1-15	34
	J3 - 3-1-15	40
	J4 - 4-1-15	46
	K1 - 58	52
	K2 - 29	54
	K2 - 35	54
	V1 - 5-19	76
028040242	V1 - 67	76
	V2 - 74	80
	A - 41	2
	E2 - 101	12
	E2 - 104	12
	E2 - 109	14
	E2 - 72	14
	E2 - 83	12
	E3 - 128-3	16
	E3 - 128-59	18
	E3 - 128-9	16
	F - 42	20
	F - 51	20
	F - 7	20
	F - 86	22
	G - 34	24
	G - 37	24
	G - 41	24
	J1 - 1-1-12	28
	J1 - 1-1-29	28
	J1 - 1-1-37	28
	J1 - 1-2-4	30
	J1 - 1-3-3	30
	J2 - 2-1-12	34
	J2 - 2-1-29	34
	J2 - 2-1-37	34
	J2 - 2-2-4	36
	J2 - 2-3-3	36
	J3 - 3-1-12	40
	J3 - 3-1-29	40
	J3 - 3-1-37	40
	J3 - 3-2-4	42
	J3 - 3-3-3	42
	J4 - 4-1-12	46
	J4 - 4-1-29	46
	J4 - 4-1-36	46
	J4 - 4-1-50	46
	J4 - 4-2-4	48
	J4 - 4-3-3	48
	K1 - 20	52
	K1 - 52	52
	K1 - 54	52
	N1 - 21	58
Q - 1-23	64	
Q - 1-33	64	
U1 - 1-9	70	
U1 - 22	70	
U1 - 26	70	
U1 - 65	72	
V1 - 108	78	
V1 - 3	76	
V2 - 103-4	82	

CODE	REF.NO.	PAGE	
028040242	V2 - 37	80	
	V2 - 95	80	
	Z1 - 108	92	
	Z1 - 13	90	
	Z1 - 16	90	
	Z1 - 25	90	
	Z1 - 31	90	
	Z2 - 108	96	
	Z2 - 13	94	
	Z2 - 16	94	
	Z2 - 25	94	
	Z2 - 31	94	
	028040243	C - 12	6
		E3 - 128-31	16
E3 - 128-42		16	
J1 - 1-1-40		28	
J1 - 1-1-50		28	
J1 - 1-4-19		30	
J2 - 2-1-40		34	
J2 - 2-1-52		34	
J2 - 2-4-20		36	
J3 - 3-1-40		40	
028050242	J3 - 3-1-52	40	
	J3 - 3-4-20	42	
	J4 - 4-1-39	46	
	J4 - 4-1-57	46	
	J4 - 4-4-19	48	
	Q - 3	64	
	V2 - 92	80	
	W1 - 29	84	
	Z1 - 50	90	
	Z2 - 50	94	
	C - 7	6	
	E1 - 16	10	
	E1 - 28	10	
	E2 - 122	14	
	E2 - 124	14	
	E2 - 65	12	
	E3 - 128-19	16	
	E3 - 128-22	16	
	E3 - 128-27	16	
	E3 - 128-46	16	
	E3 - 128-50	16	
	E3 - 128-53	16	
	E3 - 128-6	16	
	F - 12	20	
	F - 28	20	
	F - 45	20	
	F - 48	20	
	F - 79	22	
	G - 43	24	
	H1 - 11	26	
	J1 - 1-1-4	28	
	J1 - 1-1-54-4	30	
	J1 - 1-1-55-4	30	
J1 - 1-4-3	30		
J1 - 11-4	32		
J1 - 12-4	32		
J2 - 11-4	38		
J2 - 12-4	38		
J2 - 2-1-4	34		
J2 - 2-1-56-4	36		
J2 - 2-1-57-4	36		
J2 - 2-4-3	36		
J3 - 11-4	44		
J3 - 12-4	44		
J3 - 3-1-4	40		

CODE	REF.NO.	PAGE	
028050242	J3 - 3-1-57-4	42	
	J3 - 3-1-58-4	42	
	J3 - 3-4-3	42	
	J4 - 11-4	50	
	J4 - 12-4	50	
	J4 - 4-1-4	46	
	J4 - 4-1-65-4	48	
	J4 - 4-1-66-4	48	
	J4 - 4-4-3	48	
	K1 - 46	52	
	K2 - 42	54	
	K2 - 84	54	
	K2 - 89	54	
	U1 - 1-5	70	
	U1 - 9	70	
	U2 - 79-3	74	
	V2 - 20	80	
	W1 - 13	84	
	W1 - 17	84	
	W1 - 18-8	84	
	W1 - 25	84	
	W1 - 3	84	
	W1 - 6	84	
	W1 - 9	84	
	W2 - 16	86	
	W2 - 3	86	
	W2 - 8	86	
	Z1 - 28	90	
	Z1 - 54	90	
	Z1 - 77	90	
	Z2 - 123	96	
	Z2 - 28	94	
	Z2 - 54	94	
	Z2 - 77	94	
	E2 - 117	14	
	E3 - 128-25	16	
	F - 15	20	
	AC- 6-7-2	102	
	028050243	E1 - 10	10
		E2 - 45	12
		E2 - 50	12
		E2 - 54	12
		E2 - 68	12
		G - 16	24
		G - 3	24
		G - 30	24
		K1 - 64	52
K1 - 66		52	
K1 - 76		52	
U1 - 16		70	
U1 - 3		70	
028060243		J1 - 1-1-51	28
		J2 - 2-1-53	34
		J3 - 3-1-53	40
		J4 - 4-1-58	46
	Y - 2	88	
028080242	E1 - 3	10	
	E1 - 36	10	
	E1 - 7	10	
	F - 63	22	
	F - 68	22	
	F - 77	22	
	K1 - 12	52	
	K1 - 3	52	
	U2 - 78-3	74	
	V2 - 16	80	
	Z1 - 34	90	

CODE	REF.NO.	PAGE
028080242	Z1 - 37	90
	Z1 - 40	90
	Z1 - 45	90
	Z1 - 80	92
	Z2 - 34	94
	Z2 - 37	94
	Z2 - 40	94
	Z2 - 45	94
	Z2 - 80	94
	028350242	D - 45
P - 21		62
034311302	T - 1-3	68
047301042	Q - 1-15	64
048040342	D - 18	8
	D - 35	8
048050342	J1 - 1-1-23	28
	J1 - 1-1-25	28
	J2 - 2-1-23	34
	J2 - 2-1-25	34
	J3 - 3-1-23	40
	J3 - 3-1-25	40
	J4 - 4-1-23	46
	J4 - 4-1-25	46
048060342	H1 - 5	26
	R - 35	66
048070342	D - 32	8
048080142	L - 33	56
048100142	L - 11	56
048120142	E1 - 23	10
	E3 - 128-14	16
048150142	B - 8	4
048170145	R - 11	66
048220242	L - 26	56
048320242	B - 30	4
048350242	F - 4	20
	L - 8	56
050501406	AC- 6-7-5	102
050503006	AC- 25-3	102
052400806	AC- 6-7-4	102
	V2 - 64	80
	W1 - 18-12	84
	W2 - 20	86
	Z1 - 100	92
	Z2 - 100	96
	J1 - 1-2-8	30
	J2 - 2-2-8	36
	J3 - 3-2-8	42
	J4 - 4-2-8	48
060300414	Q - 1-13	64
	P - 15	62
060660512	P - 9	62
	AA- 1-8	98
061302506	Y - 3	88
062061606	J1 - 1-7	30
062300502	J2 - 2-7	36
	J3 - 3-7	42
	J4 - 4-7	48
	V2 - 53	80
	V1 - 66	76
	M - 2	58
	M - 5	58
	N2 - 52	60
	N2 - 62	60
	N2 - 83	60
R - 49	66	
062300505	V2 - 122-3	82
	V2 - 123	82

CODE	REF.NO.	PAGE
062300612	Y - 5	88
062300616	Q - 1-28	64
062300805	V2- 73	80
062400616	C - 11	6
	W1- 28	84
	Z1 - 49	90
	Z2 - 49	94
062400806	E2 - 62	12
	E3 - 128-30	16
	E3 - 128-61	18
	F - 34	20
	F - 37	20
	F - 56	20
	G - 50	24
	J1 - 1-4-16	30
	J2 - 2-4-17	36
	J3 - 3-4-17	42
	J4 - 4-4-16	48
	K1 - 60	52
	N1- 23	58
	Q - 2	64
	V1 - 12	76
	V1 - 152	78
	V1 - 55	76
	V1 - 99	78
062400812	A - 40	2
	N2- 60	60
	N2- 64	60
	P - 11	62
	R - 8	66
	U1- 21	70
062401006	A - 37	2
	J1 - 1-1-49	28
	J1 - 1-1-7	28
	J2 - 2-1-51	34
	J2 - 2-1-7	34
	J3 - 3-1-51	40
	J3 - 3-1-7	40
	J4 - 4-1-56	46
	J4 - 4-1-7	46
	V2- 91	80
062401012	A - 14	2
	A - 29	2
	A - 3	2
	B - 7	4
	L - 10	56
	N2- 45	60
	P - 13	62
	Q - 1-24	64
	Q - 1-32	64
	V2- 116	82
062401212	Y - 13	88
062401416	J1 - 1-4-17	30
	J2 - 2-4-18	36
	J3 - 3-4-18	42
	J4 - 4-4-17	48
062402016	J1 - 1-1-41	28
	J2 - 2-1-41	34
	J3 - 3-1-41	40
	J4 - 4-1-40	46
062501202	C - 5	6
	F - 78	22
062501406	AC- 6-4-1	102
062670412	B - 24	4
062670512	N2- 34	60
	N2- 43	60
062670612	B - 25	4

CODE	REF.NO.	PAGE
062670812	S - 6	68
062671612	S - 8	68
062680612	Z1 - 103	92
	Z1 - 84	92
	Z1 - 87	92
	Z2 - 103	96
	Z2 - 84	96
	Z2 - 87	96
062680712	P - 7	62
062680812	U1- 23	70
062681012	V2 - 103-7	82
062711412	D - 26	8
	R - 20	66
072060860	L - 27	56
076002450	G - 4	24
081001670	N2- 37	60
081005670	N2- 77	60
081024070	N2- 69	60
100032003	C - 15	6
	C - 26	6
	U2- 87	74
100080003	H1- 7	26
100136001	Q - 1-20	64
100191003	C - 30	6
	H2- 3	26
100251001	B - 9-2	4
	R - 29	66
100257010	D - 43	8
100260001	B - 18	4
100400000	P - 4	62
100401001	Q - 1-19	64
100402004	P - 17-3	62
100573001	P - 16	62
100645003	R - 7	66
100887001	AC- 3-1	102
101572101	AC- 2-3	102
101706001	L - 17-1	56
102538007	AC- 11-3	102
	D - 6-3	8
102571003	R - 17	66
102630001	B - 22	4
102843004	R - 5	66
103950003	P - 18	62
104449009	A - 4	2
	N2- 31	60
104450109	A - 5	2
	Y - 14	88
104464001	B - 10	4
104525001	P - 17-7	62
104821009	A - 6	2
105234003	R - 28	66
106147002	N1- 11	58
106629002	N2- 86	60
107272002	A - 18	2
	AC- 29	104
	H2- 4	26
	AC- 3-2	102
107780001	N2- 36	60
108804001	D - 17	8
109763002	S - 3	68
110161004	R - 42	66
110201001	B - 14	4
110367001	R - 34	66
	D - 1	8
111466101	P - 6	62
111469101	N2- 38	60
111863001	N2- 35	60
111865009		60

CODE	REF.NO.	PAGE
111942001	Q - 1-11	64
111943001	Q - 1-12	64
112758009	N2- 54	60
113431002	F - 89	22
114294001	P - 17-10	62
114483002	AC- 8	102
114486002	N1- 12	58
114908001	B - 19	4
115007001	L - 20	56
115157001	AC- 3-7	102
116922001	P - 17-2	62
117150001	N2- 42	60
117242001	B - 16	4
117934009	K1 - 62	52
118064001	AC- 3-5	102
118837001	AC- 2-2	102
122991001	AC- 1	102
126863001	AC- 6-10	102
133172003	N1- 13	58
140004001	B - 12-2	4
140208001	N2- 71	60
140542001	U1 - 84	72
140553102	B - 21	4
140647001	N2- 51	60
	N2- 61	60
	N2- 82	60
140682001	U1- 1-2-6	70
	U1- 7-5	70
	U2- 10-3	74
141207001	D - 3	8
141208001	D - 4	8
142359001	N2- 48	60
142403001	D - 9	8
142443001	AC- 2-1	102
142721001	AC- 3-4	102
143488000	R - 36-2	66
144086001	N2- 89	60
144504001	P - 1-3	62
144508001	N1- 10	58
145446001	P - 17-5	62
	Q - 1-18	64
145465001	B - 12-1	4
145468001	B - 17	4
145472001	D - 2	8
145474001	D - 13	8
145475101	D - 16	8
145478001	D - 21	8
145522001	P - 8	62
145571101	Q - 1-17	64
145580001	D - 12	8
145619001	N2- 56	60
145624000	B - 12-4	4
145663001	C - 33	6
145688000	B - 23	4
145737001	N2- 41	60
146049001	AC- 3-3	102
146153001	D - 34	8
146197001	Q - 1-21	64
146290001	AC- 5	102
	L - 25	56
147251009	A - 7	2
147557101	P - 3	62
147777000	B - 12-3	4
147846002	D - 41	8
148537001	R - 14	66
149173001	AC- 2-4	102
149287000	K1 - 90	52

CODE	REF.NO.	PAGE
149438000	U2- 78-1-2	74
149547000	G - 48	24
	N1 - 19	58
	V2 - 101	82
	W1- 18-10	84
	W2- 18	86
149796001	U1 - 17	70
149809000	V2 - 127	82
	V2 - 78	80
150106003	AC- 6-4	102
150145009	AC- 25	102
150172003	AC- 6-3	102
150174000	AC- 6-2-3	102
	AC- 6-5	102
150179002	AC- 6-7-1	102
150180001	AC- 6-8	102
150182000	AC- 6-9	102
150185009	AC- 25-2	102
150191002	AC- 6-2-2	102
150206002	AC- 6-2-1	102
150332001	AC- 2-5	102
150335001	AC- 3-6	102
150349001	F - 81	22
	V1 - 81	78
150357001	V1 - 82	78
150756009	A - 8	2
150949001	G - 18	24
151827000	V1 - 105	78
151987001	R - 16	66
152358001	Q - 1-4	64
152361001	Q - 1-9	64
152362001	Q - 1-10	64
152363001	Q - 1-14	64
152364001	Q - 1-16	64
152429000	V1 - 5-16	76
152430000	V1 - 5-15	76
152507000	Q - 1-26-2	64
152508000	Q - 1-26-3	64
152509000	Q - 1-26-4	64
	U1 - 1-3-4	70
152510000	V1 - 9	76
152565000	AC- 17	102
	V1 - 1-10	76
152645001	Q - 1-27	64
152857001	F - 73	22
152858001	F - 72	22
152859001	F - 71	22
152866001	A - 21	2
152867000	A - 24	2
152868009	A - 23	2
152948001	N2- 47	60
	N2- 78	60
	N2- 70	60
153112001	H1 - 4	26
153113001	U1 - 14-3	70
153252000	U1 - 7-7	70
153274001	U2- 10-5	74
153596001	B - 15	4
154024001	Q - 1-6	64
154092001	Q - 1-7	64
154125001	AC- 3-8	102
154468001	N1 - 9	58
154560001	P - 1-4	62
154567000	R - 2	66
154576001	R - 15	66
154577001	R - 18	66
154578000	R - 19	66

CODE	REF.NO.	PAGE
154579001	R - 21	66
154581001	R - 24	66
154582001	R - 26	66
154590001	R - 27	66
154593001	R - 30	66
154594000	R - 31	66
154595001	R - 32	66
154596000	R - 33	66
154598001	R - 37	66
154599000	R - 38	66
154607001	S - 5	68
154702001	AC- 7	102
155559001	R - 44	66
156112003	AC- 6-1	102
156619001	R - 9	66
156620000	R - 10	66
157706001	D - 5	8
157840000	N2- 74	60
157843001	N2- 67	60
157844000	N2- 68	60
157875000	V1 - 5-12	76
158597001	Q - 1-30	64
158598009	Q - 1-31	64
158722002	J1 - 1-1-38	28
	J1 - 1-2-2	30
	J1 - 1-3-4	30
	J2 - 2-1-38	34
	J2 - 2-2-2	36
	J2 - 2-3-4	36
	J3 - 3-1-38	40
	J3 - 3-2-2	42
	J3 - 3-3-4	42
	J4 - 4-1-37	46
	J4 - 4-2-2	48
	J4 - 4-3-4	48
158726001	B - 12-5	4
158727001	B - 12-6	4
159150009	T - 1-4	68
159324001	L - 21	56
159486001	D - 19	8
159805001	P - 17-6	62
183377001	P - 1	62
183388001	L - 24-1	56
183389001	L - 24-2	56
183390001	L - 24-3	56
183400009	AA- 6	98
183513009	P - 17	62
183532001	L - 17	56
215083001	Q - 1-3	64
	V2 - 58	80
	V2 - 96	82
	V2 - 97	82
340400001	S - 10	68
525664000	A - 36	2
	E3 - 128-60	18
	F - 36	20
	K1 - 59	52
	W1- 18-11	84
	W2- 19	86
525907000	E2 - 60	12
	F - 39	20
	V1 - 79	78
	Z1 - 98	92
	Z2 - 98	96
552851001	Q - 1-26-5	64
552907000	J1 - 1-1-6	28
	J2 - 2-1-6	34

CODE	REF.NO.	PAGE
552907000	J3 - 3-1-6	40
	J4 - 4-1-6	46
552908000	V1 - 98	78
554482000	F - 90	22
	V1 - 11	76
560196000	AB- 9-3	100
602394001	V2 - 23	80