

BUTTON FEEDER

KNOPFZUFÜHRUNG

ALIMENTATION POUR BOUTONS

BOTÓN DE ALIMENTACIÓN

BA-15

PARTS BOOK

TEILEKATALOG

LIVRE DES PIECES

LIBRO DE REFERENCIA DE PIEZAS

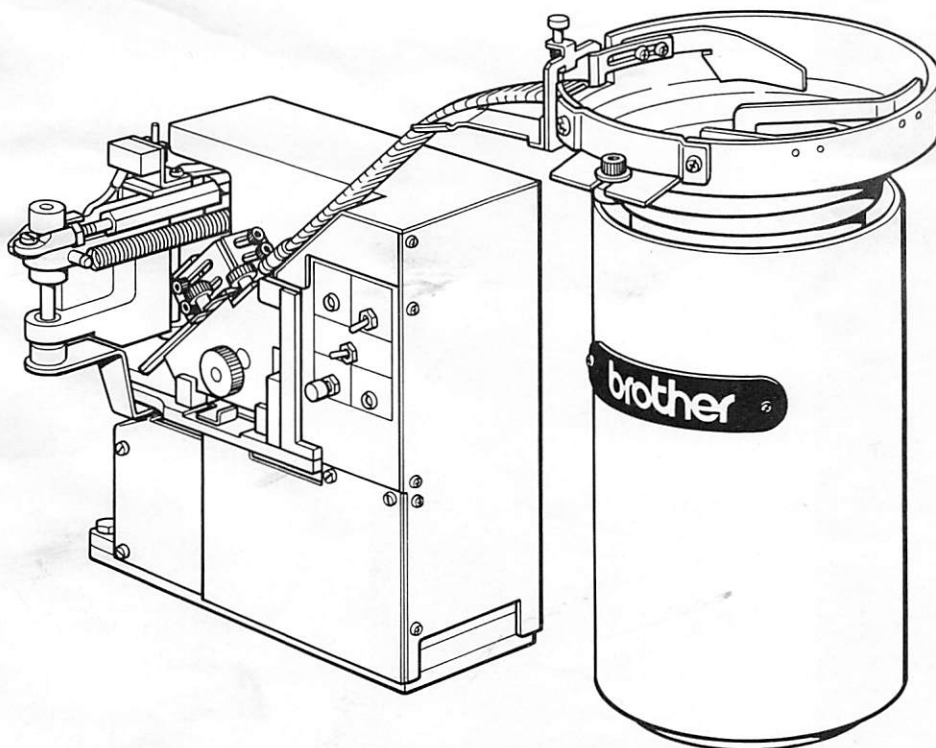

Notes for using this parts book

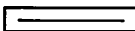
1. The symbol  in the "Parts No." column indicates that the parts is not available for supply. If, however, there is a number in the "Assembly No." column, the parts can be ordered as an assembly. Please, therefore, order by using the assembly number.
2. This book was prepared based on information available in May 1988.
3. Parts are subject to changes in design without prior notice.

Anmerkungen zum Gebrauch dieses Stücklistebuches

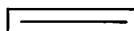
1. Dieses Zeichen  in der Spalte "Teilnummer" bedeutet, daß dieser Teil nicht lieferbar ist. Wenn jedoch in der Spalte "Gerätesatznummer" eine Nummer steht, kann dieser Teil als ein Geräteteilsatz bestellt werden. Bestellen Sie daher bitte mit dieser Gerätesatznummer.
2. Dieses Buch basiert auf den Informationen vom Mai 1988.
3. Modelländerungen sind vorbehalten.

CONTENTS

A. Machine head parts	1
B. Starting device mechanism	2
C. Button feeder mechanism (1)	3
C. Button feeder mechanism (2)	4
C. Button feeder mechanism (3)	4
C. Button feeder mechanism (4)	5
C. Button feeder mechanism (5)	6
C. Button feeder mechanism (6)	7
C. Button feeder mechanism (7)	8
C. Button feeder mechanism (8)	9
D. Button detector mechanism	9
E. Button sortor mechanism	10
F. Control box mechanism	11
G. Power supply equipment mechanism	12
OPTION PARTS	12
Z. Accessories	13
GAUGE PARTS LIST	14
INDEX	16

INHALTSVERZEICHNIS

A. Teile des Maschinenoberteils	1
B. Startvorrichtung	2
C. Knopfzuführungsvorrichtung (1)	3
C. Knopfzuführungsvorrichtung (2)	4
C. Knopfzuführungsvorrichtung (3)	4
C. Knopfzuführungsvorrichtung (4)	5
C. Knopfzuführungsvorrichtung (5)	6
C. Knopfzuführungsvorrichtung (6)	7
C. Knopfzuführungsvorrichtung (7)	8
C. Knopfzuführungsvorrichtung (8)	9
D. Knopfdetektor	9
E. Knopfsortierer	10
F. Schaltkasten	11
G. Stromversorgung	12
SONDERZUBEHÖR	12
Z. Zubehör	13
LEHRENLISTE	14
VERZEICHNIS	16

Notes sur l'utilisation de ce manuel de pièces détachées

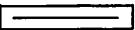
1. Le symbole  dans la colonne "N° de pièce" signifie que la pièce ne peut être fournie. Si, dans la colonne "N° jeu de pces", il y a un numéro de nomenclature, la pièce peut être commandée comme faisant partie d'un jeu pièces. Donc, pour toute commande, veuillez spécifier le n° du jeu de pièces.
2. Ce manuel a été fait d'après les renseignements valables au mois de Mai 1988.
3. Les pièces peuvent être sujettes à des modifications sans préavis.

Notas para usar este Libro de Piezas

1. El símbolo , que se encuentra en la columna del "Número de Pieza", quiere decir que no se dispone de dicha pieza sola. Cuando, empero, hay un número en la columna del "Número de Juego", se podrá ordenar la pieza con todo el juego. Por lo tanto, será mejor hacer el pedido recurriendo al número del juego respectivo.
2. Este libro ha sido compilado basándose en los datos de que se disponía en marzo 1988.
3. Las piezas quedan sujetas a cambios de diseño sin aviso previo.

TABLE DES MATIERES

A. Pièces supérieures de la machine	1
B. Mécanisme de dispositif de démarrage	2
C. Alimentation pour boutons (1)	3
C. Alimentation pour boutons (2)	4
C. Alimentation pour boutons (3)	4
C. Alimentation pour boutons (4)	5
C. Alimentation pour boutons (5)	6
C. Alimentation pour boutons (6)	7
C. Alimentation pour boutons (7)	8
C. Alimentation pour boutons (8)	9
D. Détecteur de bouton	9
E. Tricur de bouton	10
F. Mécanisme du boîtier de contrôle	11
G. Mécanisme de léquipement en alimentation électrique	12
PIEZAS OPCION	12
Z. Accessoires	13
LISTE DES PIECES D'ECARTEMENT	14
INDEX	16

INDICE

A. Piezas de la cabeza de la máquina	1
B. Mecanismo del dispositivo de arranque	2
C. Botón de alimentación (1)	3
C. Botón de alimentación (2)	4,
C. Botón de alimentación (3)	4
C. Botón de alimentación (4)	5
C. Botón de alimentación (5)	6
C. Botón de alimentación (6)	7
C. Botón de alimentación (7)	8
C. Botón de alimentación (8)	9
D. Detector de botones	9
E. Clasificador de botones	10
F. Mecanismo del caja de controles	11
G. Mecanismo de la equipo de alimentación de corriente	12
PIECES EN OPTION	12
Z. Accesorios	13
LISTA DE PIEZAS CALIBRADORAS	14
INDICE	16

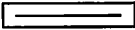
A. Machine head parts / Teile des Maschinenoberteils
Pièces supérieures de la machine / Piezas de la cabeza de la máquina

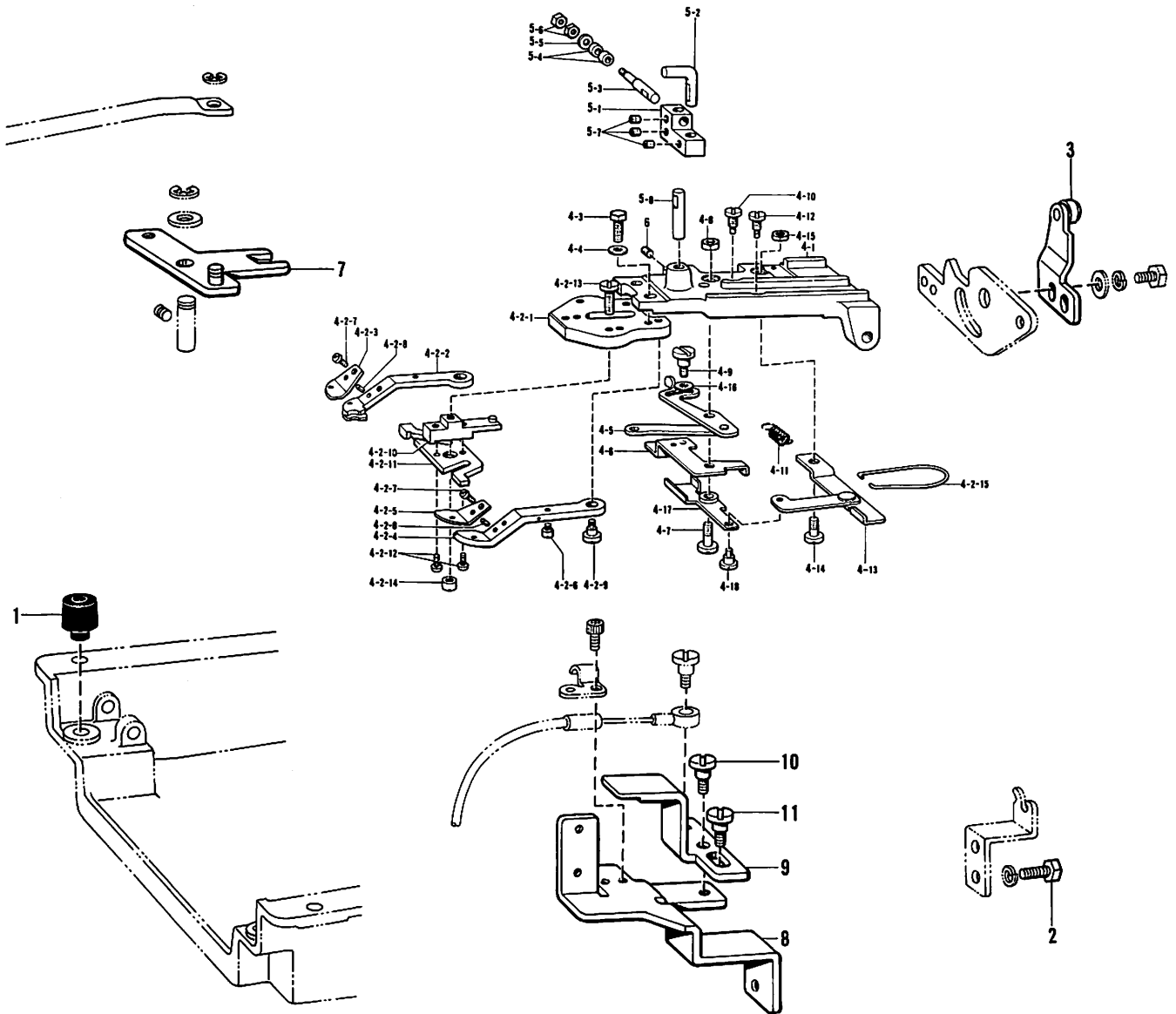

Ref.No.	Name of Parts	Q'ty	Parts No.	Ref.No.	Name of Parts	Q'ty	Parts No.
1	Cushion	2	S07979-001	4-8	Nut 6.35	1	150556-001
2	Bolt 4.76X14	2	017711-412	4-9	Stud Screw 4.37	1	115166-001
3	Starting Safety Lever Assembly	1	S12694-001	4-10	Screw	1	S03606-001
4	Button Clamp Holder Assembly	1	S07080-001	4-11	Spring	1	S03607-001
4-1	Button Clamp Holder	1	S07081-001	4-12	Spring Hook	1	S03608-001
4-2	Button Clamp Assembly 448	1	S10779-001	4-13	Opener Lever Assembly	1	S07098-001
4-2-1	Button Clamp Bracket	1	S03464-101	4-14	Screw 6.35	1	S07117-001
4-2-2	Button Clamp (L)	1	S05679-101	4-15	Nut 6.35	1	150556-001
4-2-3	Button Clamp (L) Plate Spring	1	S05680-101	4-16	Washer 4.37	1	025680-232
4-2-4	Button Clamp (R)	1	S05678-101	4-17	Button Opener Support Lever	1	S06992-001
4-2-5	Button Clamp (R) Plate Spring	1	S05681-101	4-18	Stud Screw 6.35	1	149127-001
4-2-6	Screw	2	115156-001	5	Presser Lift Holder Assembly	1	S07107-001
4-2-7	Screw 4.37X5	2	062680-512	5-1	Presser Lift Holder	1	S06995-001
4-2-8	Spring Pin AW 2.5	2	047250-642	5-2	Presser Lifter Hook (A)	1	S06998-001
4-2-9	Stud Screw 4.76	2	115158-001	5-3	Button Holder Hook	1	S06996-001
4-2-10	Button Clamp (M) Assembly (B)	1	S05687-001	5-4	Roller	2	107744-001
4-2-11	Button Clamp Plate	1	S05905-001	5-5	Washer 4.76	1	153484-001
4-2-12	Screw 4.37X8	2	062680-812	5-6	Nut 4.37	2	105234-003
4-2-13	Screw 4.37	1	S03468-001	5-7	Screw 5.95	3	014760-622
4-2-14	Nut 4.37	1	S03657-001	5-8	Holder Supporter Shaft	1	S06997-001
4-2-15	Button Clamp Spring	1	S03610-001	6	Screw 5.95	1	014760-622
4-3	Bolt 4.76X14	2	017711-412	7	Tension Release Lever Assembly	1	155571-001
4-4	Washer	2	146354-001	8	Lever Bracket	1	S07093-001
4-5	Size Adjusting Plate Assembly	1	S03800-001	9	Thread Presser Crank Lever	1	S07092-001
4-6	Button Opener Support	1	S07079-001	10	Stud Screw 4.37	1	144526-001
4-7	Screw 6.35	1	S06994-001	11	Stud Screw 4.37	2	148417-001

- ★ Replace LK3-B438 parts with those noted above.
- ★ Die Teile LK3-B438 durch die obenstehenden Teile ersetzen.
- ★ Remplacer les pièces LK3-B438 avec celles notées ci-dessus.
- ★ Cambiar las piezas de LK3-B438 con las que se mencionaron anteriormente.

B. Starting device mechanism / Startvorrichtung
Mécanisme de dispositif de démarrage / Mecanismo del dispositivo de arranque

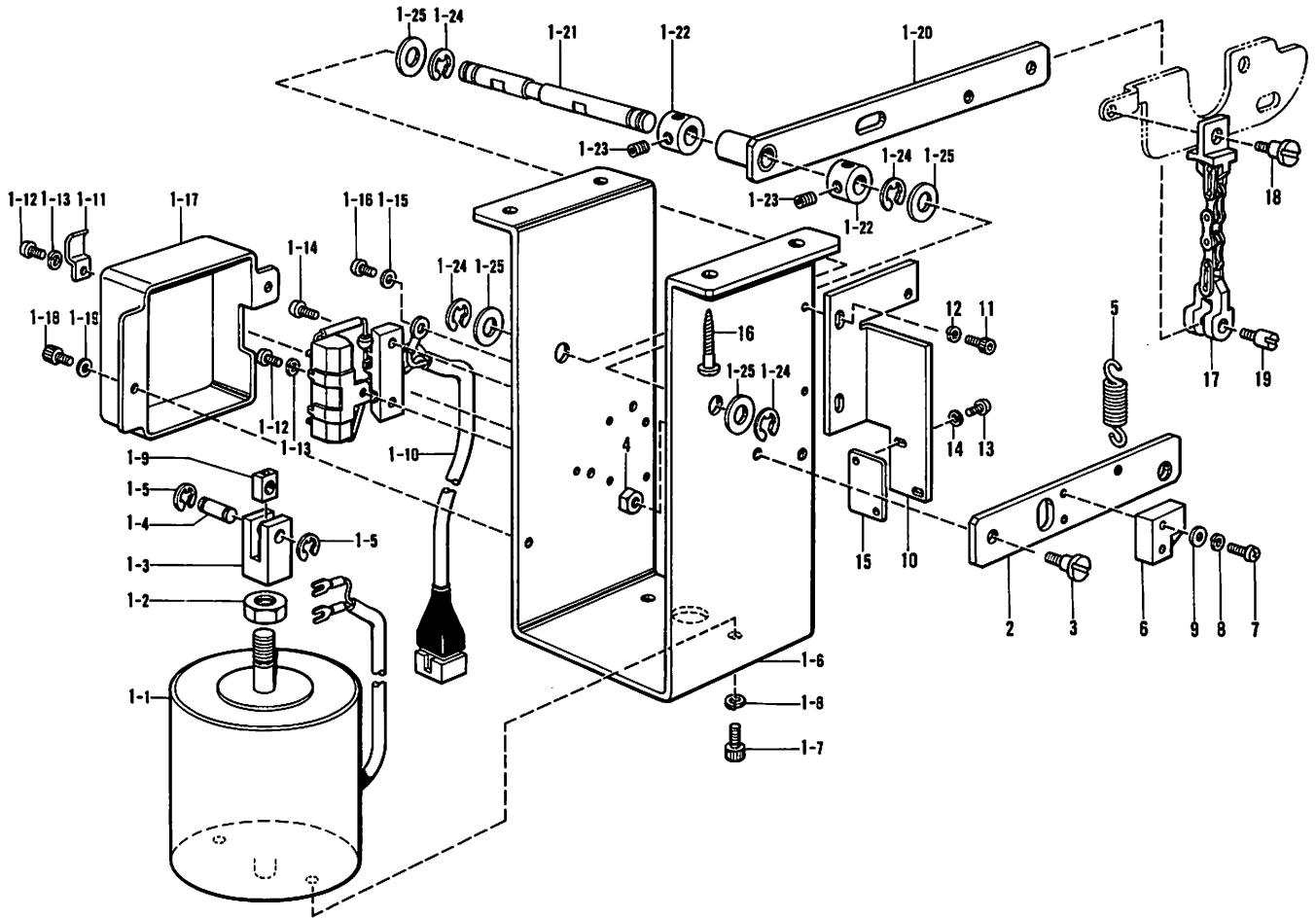

Ref.No.	Name of Parts	Q'ty	Parts No.	Ref.No.	Name of Parts	Q'ty	Parts No.
1	Starting Device Assembly	1	S07108-001	1-22	Set Collar	2	S05392-001
1-1	Starting Solenoid	1	S10549-000	1-23	Screw 6X6	4	014060-632
1-2	Nut 8	1	021080-302	1-24	Stop Ring E4	4	048080-342
1-3	Plunger Connector	1	S09636-001	1-25	Washer 10	4	025100-132
1-4	Pin	1	S09637-001	2	Foot Switch Lever	1	S05881-001
1-5	Stop Ring E4	2	048040-342	3	Stud Screw 8.35	2	158998-001
1-6	Solenoid Bracket	1	S07055-001	4	Nut 6.35	2	150554-002
1-7	Bolt 6X12	2	018061-222	5	Foot Switch Lever Spring	1	S05882-001
1-8	Spring Washer 2-6	2	028060-243	6	Switch Dock	1	S05884-000
1-9	Needle Bar Guide Slide Block	1	102630-001	7	Screw 4X14	2	002401-402
1-10	Terminal Block Assembly	1	S11073-000	8	Spring Washer 2-4	2	028040-242
1-11	Cord Holder L	1	142268-001	9	Washer 4	2	025040-232
1-12	Screw 3X6	2	002300-603	10	Switch Setting Plate	1	S07138-001
1-13	Spring Washer 2-3	2	028030-242	11	Bolt 4X8	2	018400-832
1-14	Screw 3X10	2	002301-003	12	Spring Washer 2-4	2	028040-242
1-15	Washer	1	S02745-001	13	Screw 3X16	2	002301-603
1-16	Screw 4X6	1	002400-663	14	Spring Washer 2-3	2	028030-243
1-17	Terminal Block Cover	1	S02592-001	15	Setting Plate	1	S05973-001
1-18	Bolt 4X8	2	018400-832	16	Screw 6.2X32	4	101125-000
1-19	Washer 4	2	025040-232	17	3P Chain Assembly	1	S07172-001
1-20	Starting Lever	1	S07099-001	18	Stud Screw 5.35	1	159394-001
1-21	Starting Lever Shaft	1	S07122-001	19	Supporter Shaft	1	115544-001

C. Button feeder mechanism (1) / Knopfzuführungvorrichtung (1)
 Alimentation pour boutons (1) / Botón de alimentación (1)

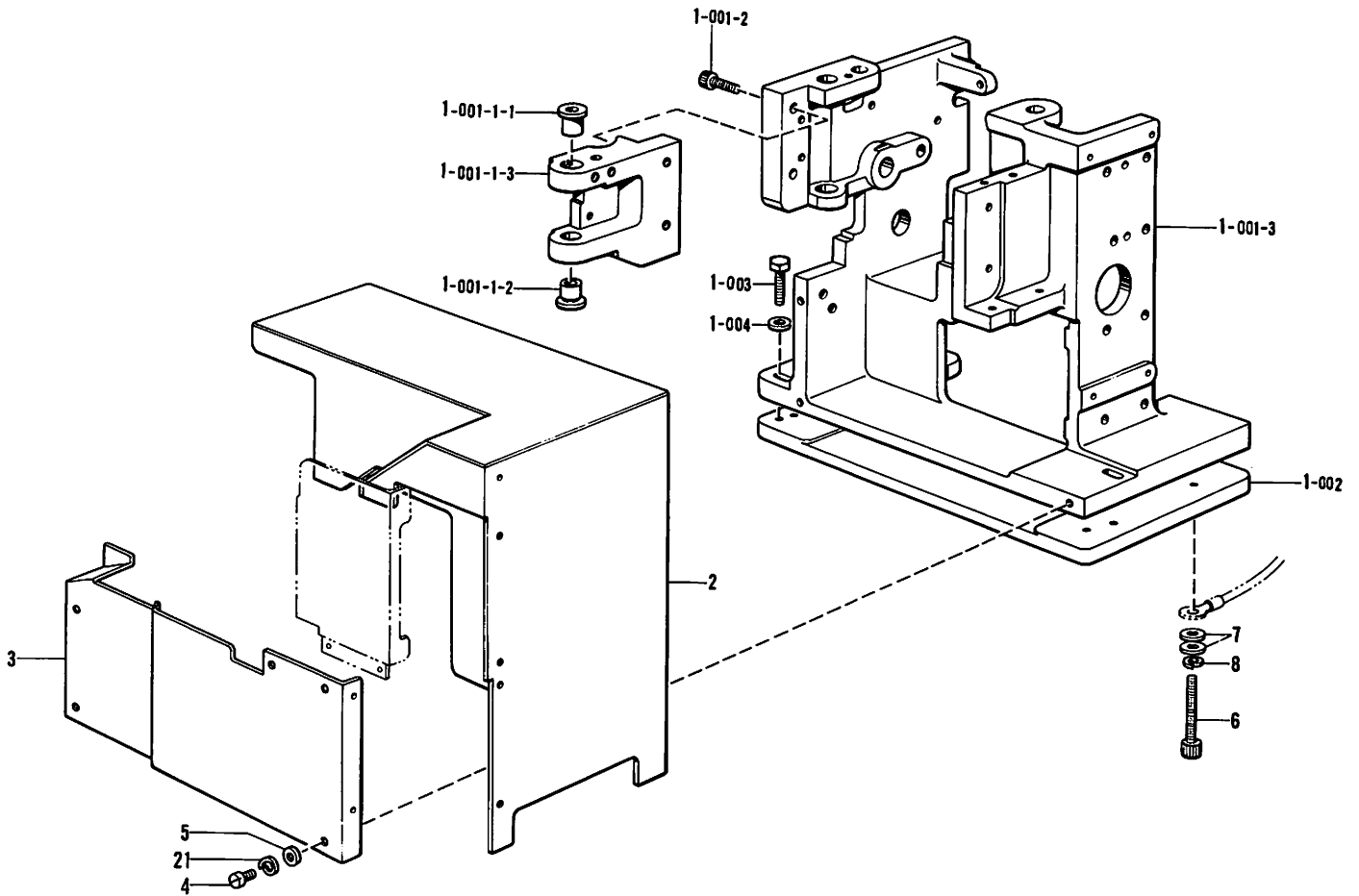

Ref.No.	Name of Parts	Q'ty	Parts No.	Ref.No.	Name of Parts	Q'ty	Parts No.
1	Button Feeder Machine Body Assembly	1	S07102-001	1-004	Washer 6	3	025060-232
1-001	Feeder Machine Body Assembly	1	S07067-001	2	Machine Body Cover Assembly	1	S07060-001
1-001-1	Button Carry Supporting Bracket (L) Assembly	1	S07065-001	3	Front Cover	1	S10504-001
1-001-1-1	Bushing (U)	1	S05378-000	4	Screw 4X8	12	062400-806
1-001-1-2	Bushing (D)	1	S05379-000	5	Washer 4	11	025040-232
1-001-1-3	Button Carry Supporting Bracket (L)	1	S07062-001	6	Bolt 6X50	3	018065-022
1-001-2	Bolt 6X20	3	018062-022	7	Washer	6	115947-001
1-001-3	Button Feeder Machine Body	1	S07064-001	8	Spring Washer 2-6	3	028060-242
1-002	Button Feeder Base	1	S07061-001	21	Spring Washer 2-4	12	028040-243
1-003	Bolt 6X20	3	017062-003				

C. Button feeder mechanism (2) / Knopfzuführungvorrichtung (2)
Alimentation pour boutons (2) / Botón de alimentación (2)

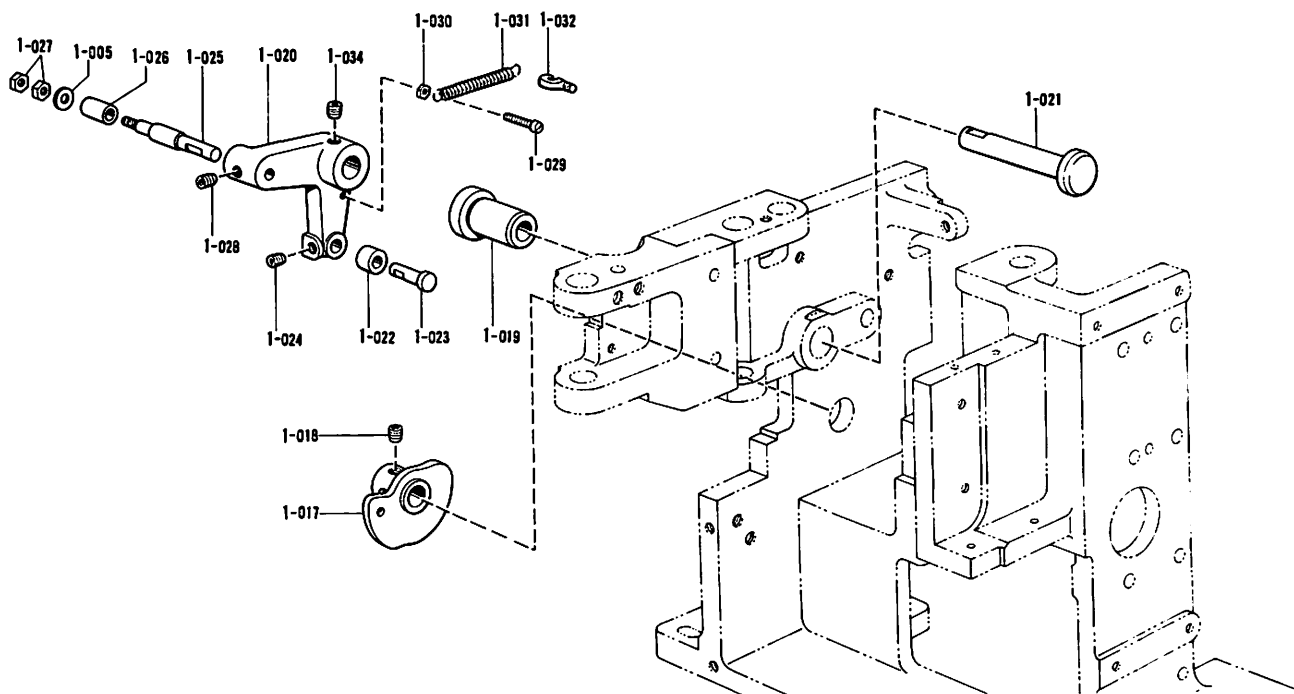

Ref.No.	Name of Parts	Q'ty	Parts No.	Ref.No.	Name of Parts	Q'ty	Parts No.
1-005	Washer 4.16	1	153484-001	1-025	Presser Lifting Roller Arm Shaft	1	S07072-001
1-017	Presser Lifting Cam	1	S05384-001	1-026	Presser Lifting Roller	1	S07071-001
1-018	Screw 6X6	2	014060-632	1-027	Nut 4.37	2	105234-003
1-019	Crank Shaft Bearing	1	S05385-000	1-028	Screw 6X6	1	014060-622
1-020	Presser Lifting Crank	1	S07073-001	1-029	Screw 3X12	1	007301-212
1-021	Presser Lifting Crank Shaft	1	S05387-001	1-030	Nut 3	1	021300-103
1-022	Cam Supporter	1	S05371-001	1-031	Spring	1	S05391-001
1-023	Shaft	1	S05388-001	1-032	Spring Hook	1	141334-001
1-024	Screw 5	1	014500-522	1-034	Screw 6X6	2	014060-632

C. Button feeder mechanism (3) / Knopfzuführungvorrichtung (3)
Alimentation pour boutons (3) / Botón de alimentación (3)

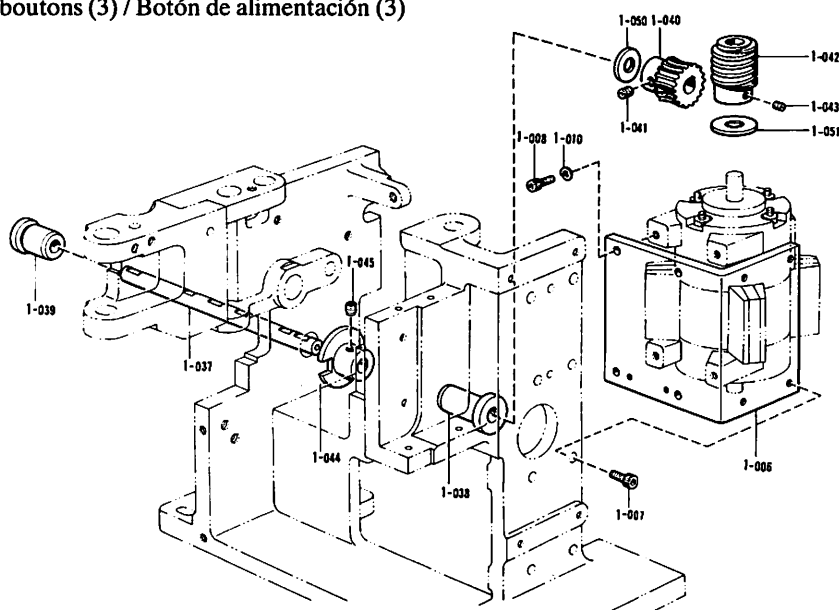

Ref.No.	Name of Parts	Q'ty	Parts No.	Ref.No.	Name of Parts	Q'ty	Parts No.
1-006	Motor Setting Plate	1	S07110-001	1-041	Screw 6X6	2	014060-632
1-007	Bolt 4X10	4	018401-022	1-042	Worm	1	S05332-000
1-008	Bolt 4X10	4	018401-022	1-043	Screw 5	2	014500-522
1-010	Spring Washer 2-4	4	028040-242	1-044	Cam Shaft Switch Dock	1	S05333-001
1-037	Cam Shaft	1	S07070-001	1-045	Screw 6X6	2	014060-632
1-038	Cam Shaft Bushing (F)	1	S05329-000	1-050	Washer	1	S06024-001
1-039	Cam Shaft Bushing (R)	1	S05330-000	1-051	Washer	1	S06029-001
1-040	Worm Wheel	1	S05331-000				

C. Button feeder mechanism (4) / Knopfzuführungvorrichtung (4)
Alimentation pour boutons (4) / Botón de alimentación (4)

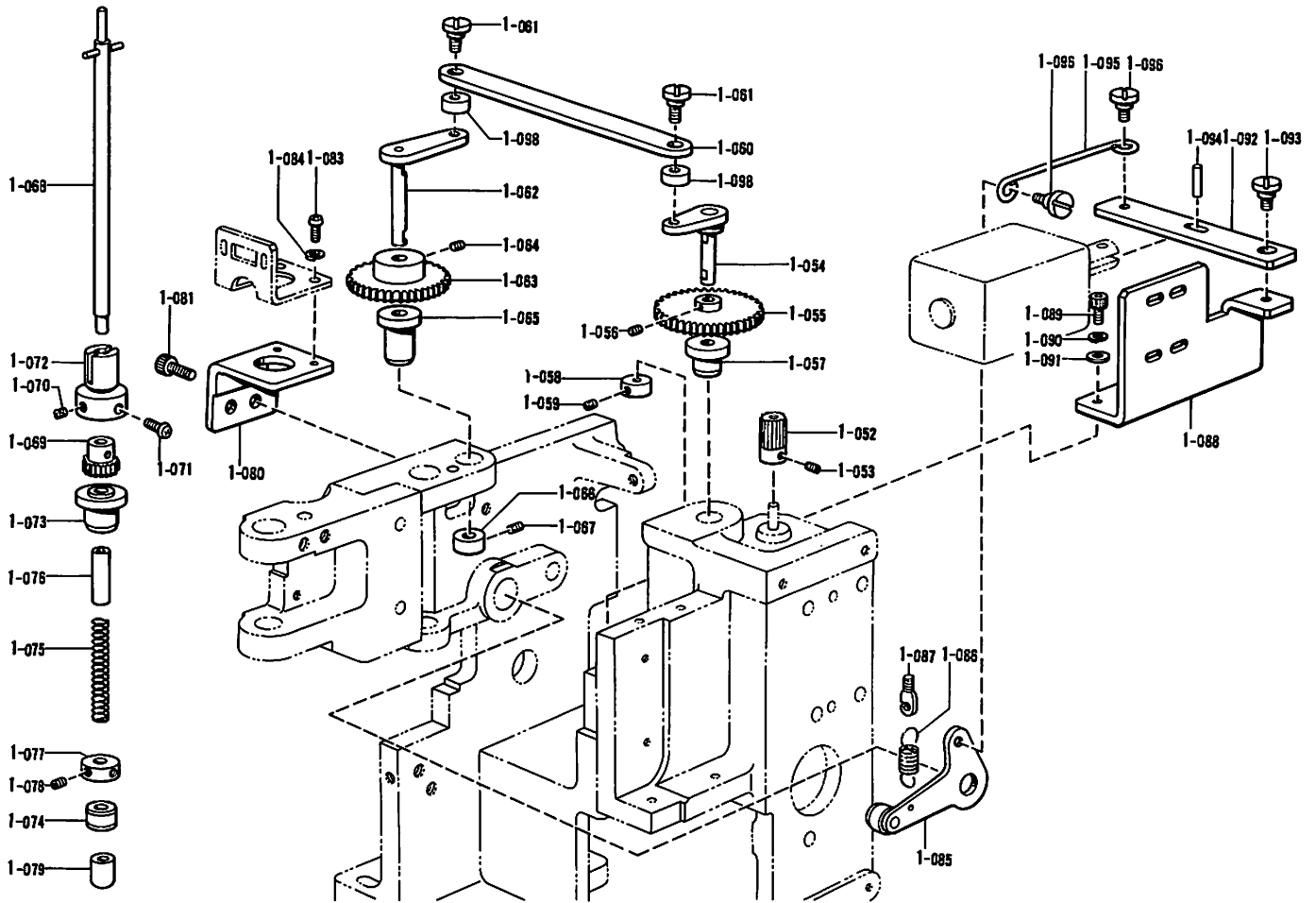

Ref.No.	Name of Parts	Q'ty	Parts No.	Ref.No.	Name of Parts	Q'ty	Parts No.
1-052	Button Alignment Motor Gear	1	S05334-000	1-075	Button Alignment Press Spring	1	S10704-001
1-053	Screw 3X4	2	014300-432	1-076	Spring Guide Collar	1	S10708-001
1-054	Gear Shaft (A)	1	S05335-001	1-077	Button Alignment Shaft Dock	1	S10707-001
1-055	Button Alignment Gear	1	S05337-000	1-078	Screw 4X5	2	014400-522
1-056	Screw 3X4	2	014300-432	1-079	Button Presser (C)	1	S06570-000
1-057	Gear Shaft (A) Bushing	1	S05338-000	1-080	Guide	1	S07074-001
1-058	Collar (A)	1	S05339-001	1-081	Bolt 4X10	2	018401-022
1-059	Screw 3X4	2	014300-432	1-083	Screw 3X8	2	002300-803
1-060	Button Alignment Connection Lever	1	S05340-001	1-084	Spring Washer 2-3	2	028030-242
1-061	Stud Screw M4	2	S05341-001	1-085	Presser Bar Clank Assembly	1	S05358-001
1-062	Gear Shaft (B)	1	S05342-001	1-086	Spring	1	S05363-001
1-063	Shaft Gear (A)	1	S05343-000	1-087	Spring Hook	1	141334-001
1-064	Screw 5	2	014500-522	1-088	Solenoid Setting Plate	1	S05364-001
1-065	Gear Shaft (B) Bushing	1	S05344-000	1-089	Bolt 4X18	3	018401-022
1-066	Collar (B)	1	S05345-001	1-090	Spring Washer 2-4	3	028040-242
1-067	Screw 5	2	014500-522	1-091	Washer 4	3	025040-232
1-068	Shaft Assembly	1	S10701-001	1-092	Solenoid Arm	1	S05365-001
1-069	Shaft Gear (B)	1	S10703-000	1-093	Stud Screw M4	1	S05341-001
1-070	Screw 3X4	1	014300-432	1-094	Plunger Pin	1	148546-001
1-071	Screw 3X5	1	002300-502	1-095	Wire	1	S05367-001
1-072	Button Alignment Shaft Guide	1	S10709-001	1-096	Stud Screw M4	2	S05341-001
1-073	Button Alignment Shaft Bushing (A)	1	S10705-000	1-098	Roller	2	S05972-000
1-074	Button Alignment Shaft Bushing (B)	1	S10706-000				

C. Button feeder mechanism (5) / Knopfzuführungsvorrichtung (5)
Alimentation pour boutons (5) / Botón de alimentación (5)

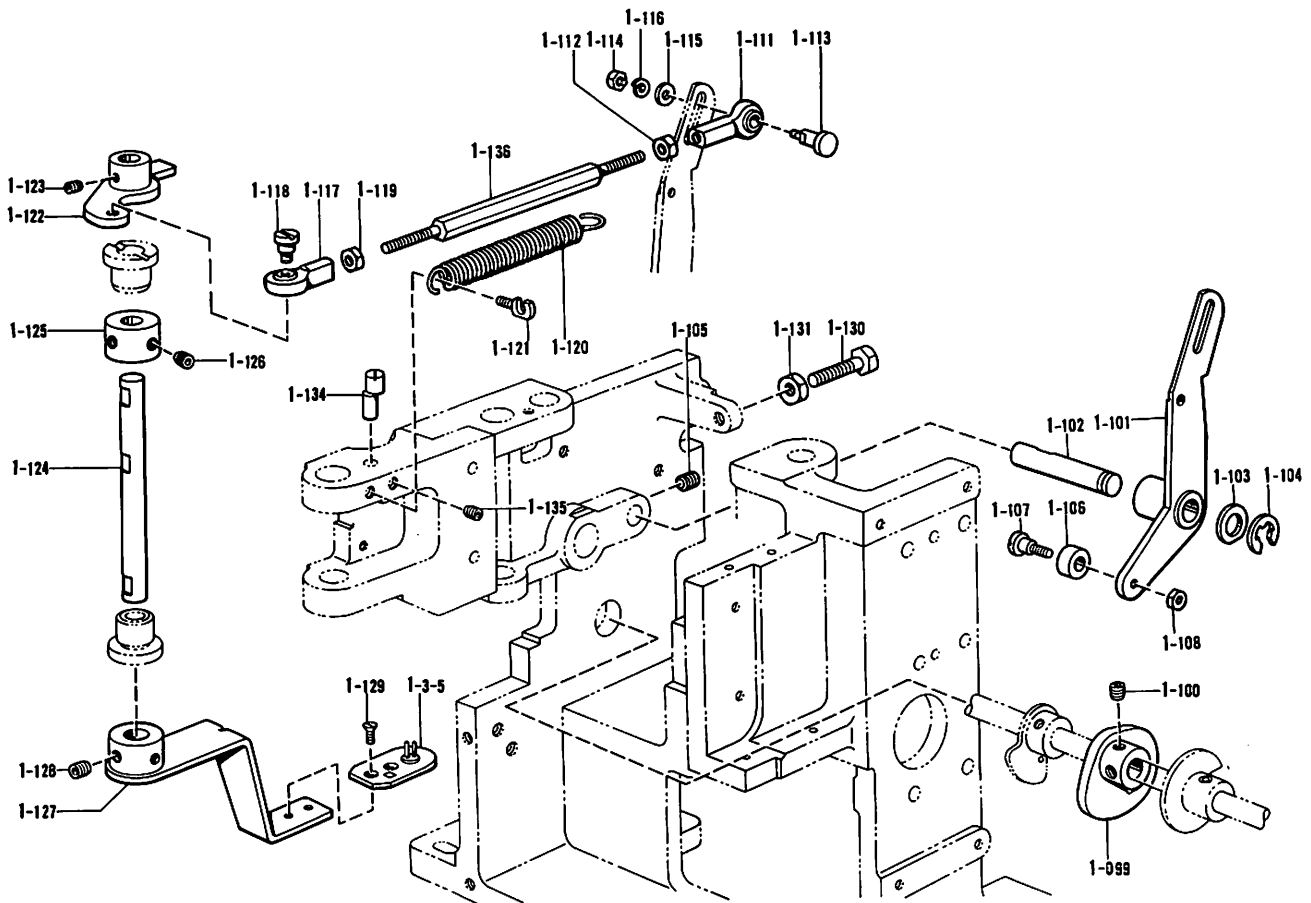

Ref.No.	Name of Parts	Q'ty	Parts No.	Ref.No.	Name of Parts	Q'ty	Parts No.
1-099	Button Carry Cam	1	S05368-101	1-119	Nut 5.95	1	148592-001
1-100	Screw 6X6	2	014060-632	1-120	Cam Supporting (B) Spring(A)	1	S05375-001
1-101	Cam Supporting (B) Arm	1	S05369-001	1-121	Spring Hook	1	141334-001
1-102	Arm (B) Fulcrum Pin	1	S05370-001	1-122	Button Movement Arm (B)	1	S05376-001
1-103	Washer	1	110367-001	1-123	Screw 6X6	2	014060-632
1-104	Stop Ring E6	1	048060-342	1-124	Button Transport Shaft	1	S07128-001
1-105	Screw 6X6	1	014060-632	1-125	Set Collar	1	S07129-001
1-106	Cam Supporting	1	S05371-001	1-126	Screw 6X6	2	014060-622
1-107	Stud Screw M4	1	S05341-001	1-127	Button Movement Arm (A)	1	S07075-001
1-108	Nut 4	1	021400-202	1-128	Screw 6X6	2	014060-632
1-111	Ball Bearing Assembly (R)	1	148587-001	1-129	Screw 3.57X4	2	S06044-001
1-112	Nut 5.95	1	100022-005	1-130	Bolt 6X25	1	S12415-001
1-113	Stud Screw	1	S05373-001	1-131	Nut 6	1	021060-106
1-114	Nut 4	1	021400-202	1-134	Pin	1	S06119-001
1-115	Washer 4	1	025040-232	1-135	Screw 5.95	1	014760-622
1-116	Spring Washer 2-4	1	028040-242	1-136	Connection Shaft	1	S07076-001
1-117	Joint Assembly (L)	1	148589-001	1-3-5	Button Catch Plate Assembly (3.2mm)	1	S06688-004
1-118	Stud Screw	1	S05336-001				

C. Button feeder mechanism (6) / Knopfzuführungvorrichtung (6)
Alimentation pour boutons (6) / Botón de alimentación (6)

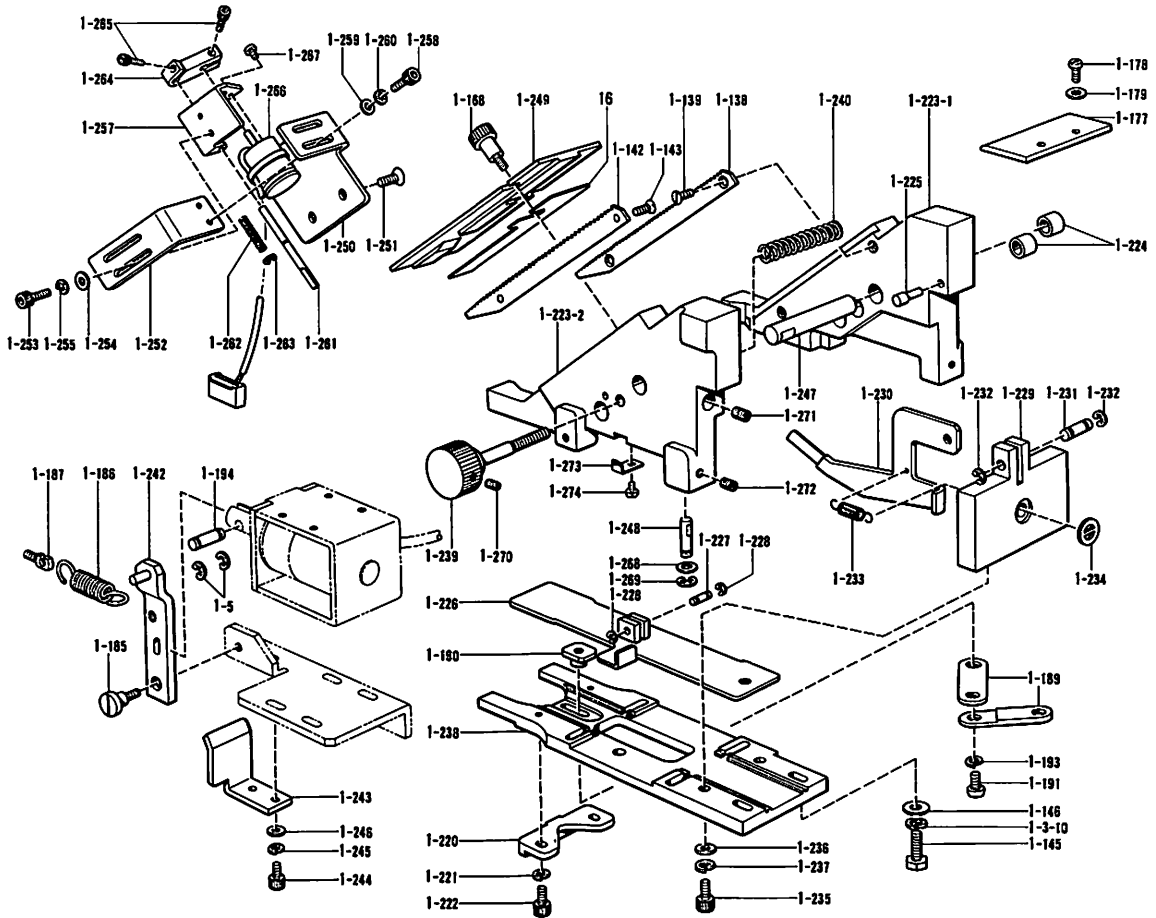

Ref.No.	Name of Parts	Q'ty	Parts No.	Ref.No.	Name of Parts	Q'ty	Parts No.
1-138	Button Slide Plate (A)	1	S05394-001	1-239	Slide Base Screw Assembly	1	S09590-001
1-139	Screw 3.57X6	2	S01696-001	1-240	Slide Base Spring	1	S09574-001
1-142	Button Slide Plate (B)	1	S05397-001	1-242	Catch Plate Mobile Lever	1	S09581-001
1-143	Screw 3.57X6	2	S01696-001	1-243	Mobile Lever Patch	1	S09579-001
1-145	Bolt 5X16	2	017501-602	1-244	Bolt 4X8	2	018400-822
1-146	Washer 5	2	025050-232	1-245	Spring Washer 2-4	2	028040-242
1-166	Screw 3.57	1	S10512-001	1-246	Washer 4	2	025040-232
1-177	Slide Base Upper Plate	1	S05421-001	1-247	Slide Base Guide Shaft	2	S09577-001
1-178	Screw 3X8	2	002300-803	1-248	Slide Base Guide Shaft	4	S09576-001
1-179	Washer 3	2	025030-233	1-249	Button Upper Cover (A)	1	S09601-100
1-185	Stud Screw M4	1	S05424-001	1-250	Solenoid Base	1	S09584-001
1-186	Shutter Spring	1	S09609-001	1-251	Screw 5X8	2	061500-804
1-187	Spring Hook	1	141334-001	1-252	Solenoid Fixing Plate	1	S09585-001
1-189	Slide Base Link	2	S05888-001	1-253	Bolt 4X8	2	018400-822
1-190	Link Fulcrum	1	S05889-001	1-254	Washer 4	2	025040-232
1-191	Screw M 4X6	1	062400-616	1-255	Spring Washer 2-4	2	028040-242
1-193	Spring Washer 2-4	1	028040-242	1-257	Stopper Shaft Supporting Plate	1	S09586-001
1-194	Plunger Pin	1	S06671-001	1-258	Bolt 4X8	2	018400-822
1-220	Button Catch Base Stopper	1	S09600-001	1-259	Washer 4	2	025040-232
1-221	Spring Washer 2-4	2	028040-242	1-260	Spring Washer 2-4	2	028040-242
1-222	Bolt 4X10	2	018401-022	1-261	Stopper Shaft	1	S09575-001
1-223	Slide Base Assembly	1	S09596-001	1-262	Stopper Spring	1	S09573-001
1-223-1	Button Slide Base (A)	1	S09597-001	1-263	Stop Ring E2.5	1	048025-342
1-223-2	Button Slide Base (B)	1	S09598-001	1-264	Stopper Shaft Support	1	S09572-001
1-224	Slide Bush	4	S09599-000	1-265	Bolt 3X8	2	018300-822
1-225	Slide Base Stopper	2	S09591-000	1-266	Stopper Solenoid	1	S09611-000
1-226	Button Catch Plate Assembly	1	S09582-001	1-267	Screw 26X4	2	062260-406
1-227	Stopper Driving Shaft	1	S09578-001	1-268	Washer 5	4	025050-232
1-228	Stop Ring E2	2	048020-342	1-269	Stop Ring E3	4	048030-342
1-229	Stopper Support	1	S09592-001	1-270	Screw 5	1	014500-522
1-230	Stopper (A)	1	S09593-001	1-271	Screw 6X6	2	014060-622
1-231	Stopper (A) Supporting Shaft	1	S09587-001	1-272	Screw 4X5	4	014400-522
1-232	Stop Ring E3	2	048030-342	1-273	Spring Plate	1	S09613-001
1-233	Slider Spring	1	S07091-001	1-274	Screw 3.57X5	1	062670-512
1-234	Tension Releasing Disc	1	152877-001	1-3-10	Spring Washer M5	1	028050-242
1-235	Bolt 5X16	2	018051-622	1-5	Stop Ring E2	2	048020-342
1-236	Washer 5	2	025050-232	16	Spacer (8.4mm) (for Supply)	1	S09604-000
1-237	Spring Washer 2-5	2	028050-242	16	Spacer (8.8mm) (for Supply)	1	S09605-000
1-238	Slide Base Lower Base	1	S09594-001				

C. Button feeder mechanism (7) / Knopfzuführungvorrichtung (7)
 Alimentation pour boutons (7) / Botón de alimentación (7)

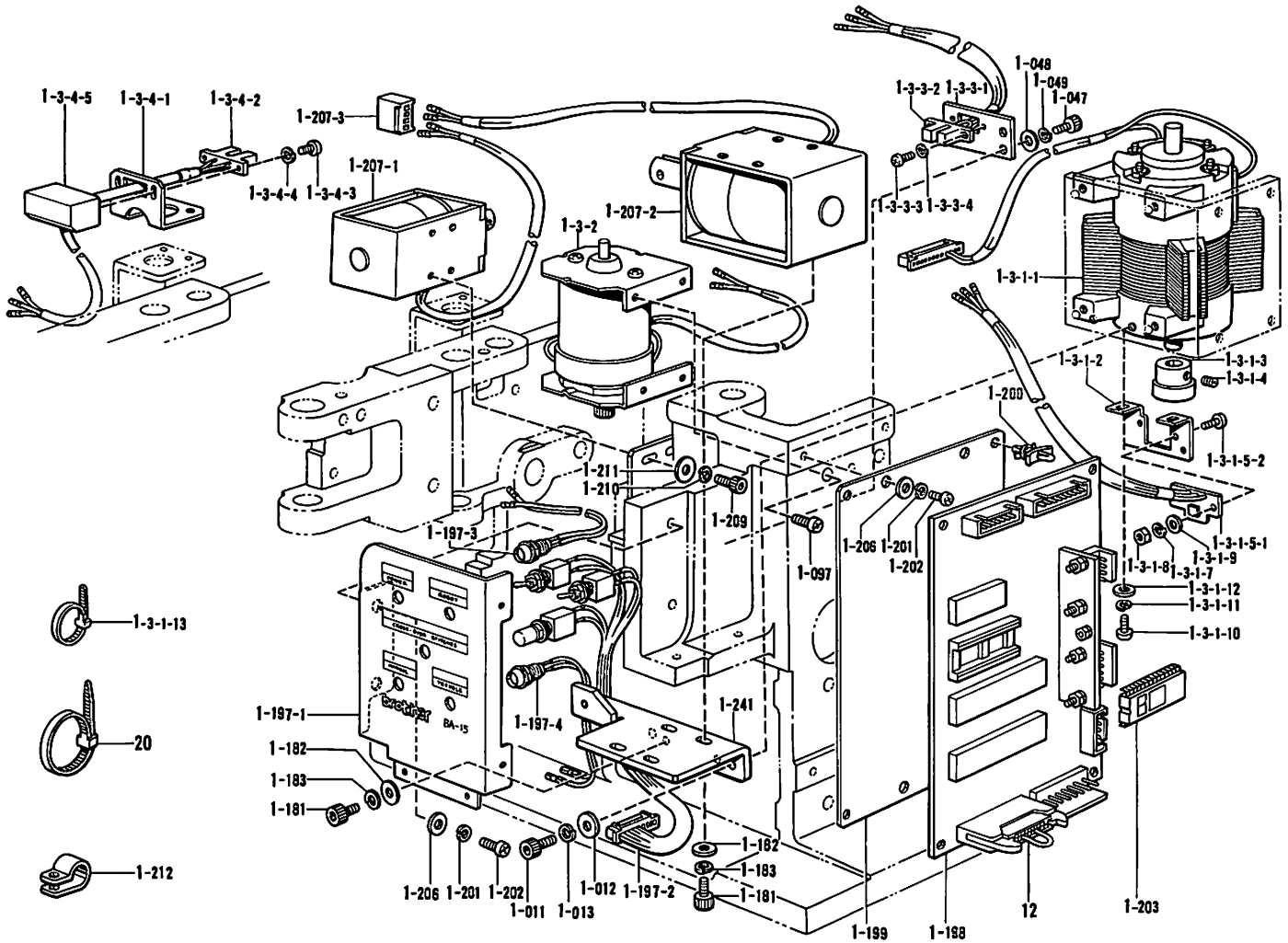

Ref.No.	Name of Parts	Q'ty	Parts No.	Ref.No.	Name of Parts	Q'ty	Parts No.
1-011	Bolt 5X12	2	018501-222	1-3	B Motor Assembly	1	S07137-001
1-012	Washer 5	2	025050-232	1-3-1	Carry Motor Assembly	1	S07136-001
1-013	Spring Washer 2-5	2	028050-242	1-3-1-1	Carry Motor	1	
1-047	Bolt 4X10	2	018401-022	1-3-1-2	Board Support	1	
1-048	Washer 4	2	025040-232	1-3-1-3	Magnet Assembly (B)	1	
1-049	Washer 2-4	2	028040-242	1-3-1-4	Screw 3X5	2	014300-522
1-097	Screw 3.5X8	4	002350-806	1-3-1-5	Rotational Sensor Assembly	1	S05729-001
1-181	Bolt 4X10	6	018401-022	1-3-1-5-1	Rotational Sensor #2	1	
1-182	Washer 4	6	025040-232	1-3-1-5-2	Screw 3X6	2	002300-603
1-183	Spring Washer 2-4	6	028040-242	1-3-1-7	Spring Washer 2-3	2	028030-243
1-197	B Panel Assembly	1	S07056-001	1-3-1-8	Nut 3	2	021300-103
1-197-1	B Panel	1		1-3-1-9	Washer 3	2	025030-233
1-197-2	B Panel Switch	1		1-3-1-10	Screw 3X8	2	002300-803
1-197-3	Power Supply (PL)	1		1-3-1-11	Spring Washer 2-3	2	028030-243
1-197-4	Trouble (PL)	1		1-3-1-12	Washer 3	2	025030-233
1-198	Printed Circuit Board	1	S05323-100	1-3-1-13	Band PLTIM	1	S04557-000
1-199	Board Setting Plate	1	S05324-001	1-3-2	Button Setting Motor Assembly	1	S05730-001
1-200	Support 6NS	4	S00554-000	1-3-3	Zero-Position Switch Assembly	1	S05731-001
1-201	Spring Washer 2-4	6	028040-243	1-3-3-1	Sensor Setting Plate	1	
1-202	Screw 4X8	6	062400-806	1-3-3-2	Sensor (A)	1	
1-203	PROM 915A Assembly	1	S12416-000	1-3-3-3	Screw 3X8	2	002300-803
1-206	Washer 4	6	025040-233	1-3-3-4	Spring Washer 2-3	2	028030-243
1-207	B Solenoid Assembly	1	S05738-001	1-3-4	Button Setting Switch Assembly	1	S05734-001
1-207-1	Button Setting Solenoid	1		1-3-4-1	Sensor Setting Plate	1	
1-207-2	Shutter Solenoid Assembly	1		1-3-4-2	Sensor (B)	1	
1-207-3	Connector VHR-4N	1		1-3-4-3	Screw 3X10	2	002301-003
1-209	Bolt 4X8	4	018400-832	1-3-4-4	Spring Washer 2-3	2	028030-243
1-210	Spring Washer 2-4	4	028040-242	1-3-4-5	Sensor Cover	1	
1-211	Washer 4	4	025040-232	12	Connector 917 Assembly	1	S05326-000
1-212	Cord Holder	2	149073-001	20	Band PLTIM	2	S04557-000
1-241	Solenoid Base	1	S07069-001				

C. Button feeder mechanism (8) / Knopfzuführungvorrichtung (8)
Alimentation pour boutons (8) / Botón de alimentación (8)

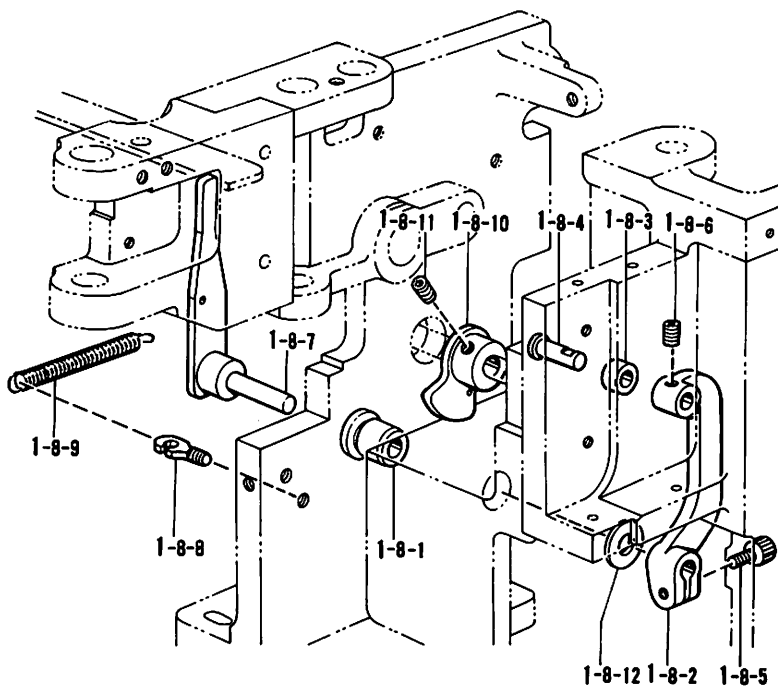

Ref.No.	Name of Parts	Q'ty	Parts No.	Ref.No.	Name of Parts	Q'ty	Parts No.
1	Button Detector Sensor Assembly	1	S07105-001	1-5	Band PLTIM	1	_____
1-1	Sensor Setting Plate	1	_____	2	Bolt 4X8	2	018400-832
1-2	Sensor (G)	1	_____	3	Spring Washer 2-4	2	028040-242
1-3	Screw 3X8	2	002300-803	4	Washer 4	2	025040-232
1-4	Spring Washer 2-3	2	028030-243				

D. Button detector mechanism / Knopfdetektor
Détecteur de bouton / Detector de botones

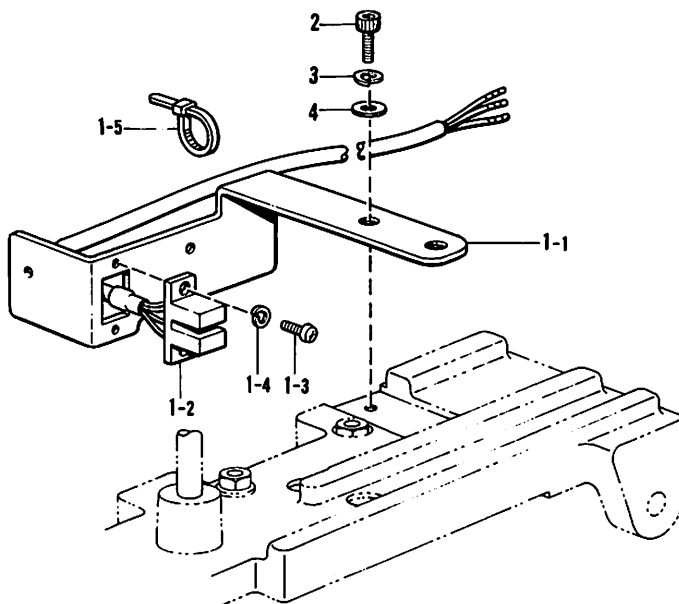

Ref.No.	Name of Parts	Q'ty	Parts No.	Ref.No.	Name of Parts	Q'ty	Parts No.
1-8-1	Button Opener Cam Shaft Bearing	1	S07051-000	1-8-7	Button Opener Lever	1	S07053-001
1-8-2	Button Opener Cam Lever	1	S07052-001	1-8-8	Spring Hook	1	141334-001
1-8-3	Cam Supporting	1	S05371-001	1-8-9	Spring	1	S05391-001
1-8-4	Shaft	1	S05388-001	1-8-10	Button Opener Cam	1	S07054-001
1-8-5	Bolt 5X12	1	018501-222	1-8-11	Screw 6X6	2	014060-622
1-8-6	Screw 5	1	014500-522	1-8-12	Washer	1	S07127-001

**E. Button sorter mechanism / Knopfsortierer
Tricur de bouton / Clasificador de botones**

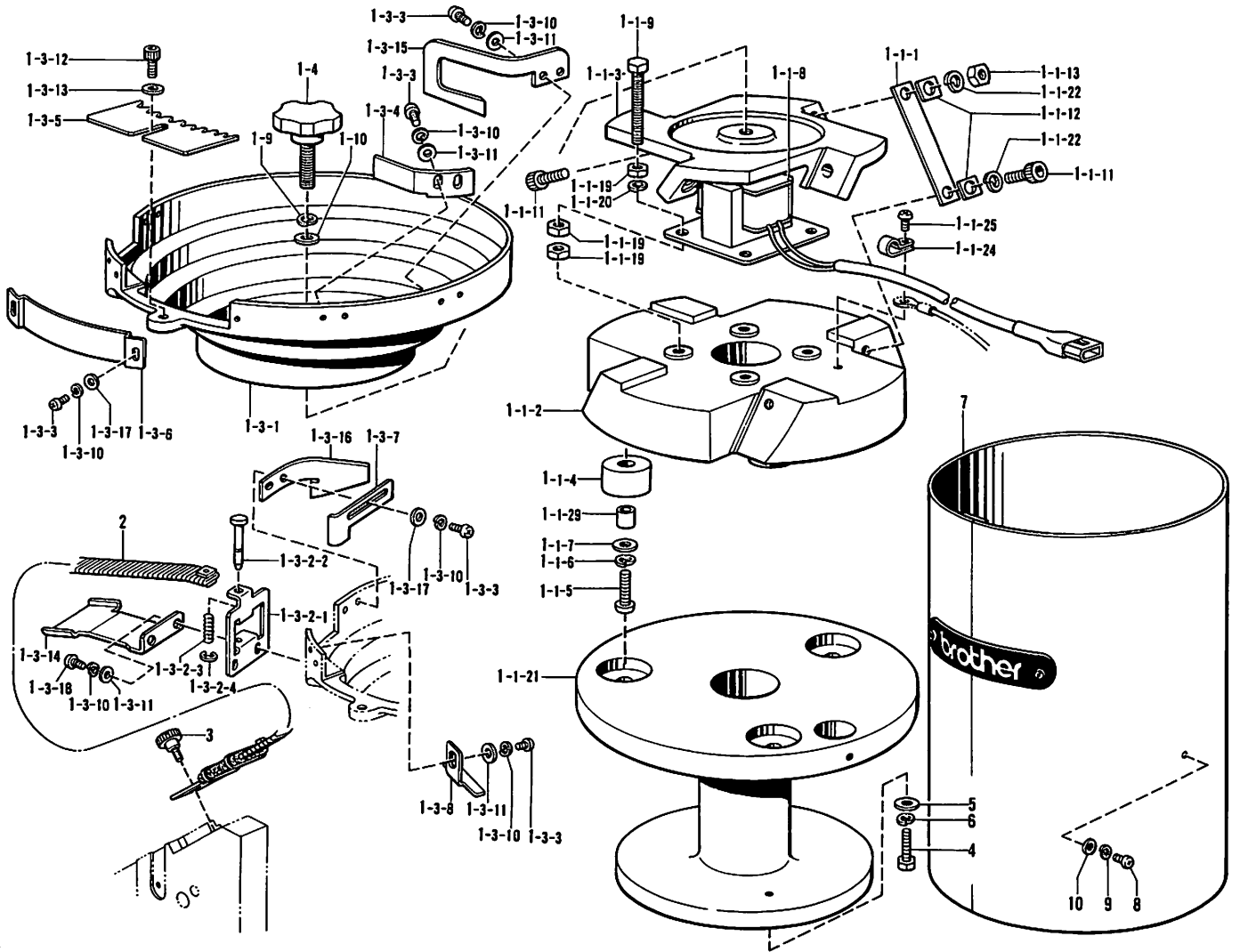

Ref.No.	Name of Parts	Q'ty	Parts No.	Ref.No.	Name of Parts	Q'ty	Parts No.
1	Vibrating Generate Assembly (50HZ)	1	S05426-101	1-3-2-3	Spring	1	S05431-001
	Vibrating Generate Assembly (60HZ)	1	S05426-102	1-3-2-4	Stop Ring E2.5	1	048025-342
1-1	Vibrating Assembly (50HZ)	1	S05427-101	1-3-3	Screw 4X8	9	062400-806
	Vibrating Assembly (60HZ)	1	S05427-102	1-3-4	Alignment Plate (A)	1	S07163-001
1-1-1	Spring Plate 0.8 (50HZ)	4	S06033-001	1-3-5	Sorting Plate	1	S05433-000
	Spring Plate 1.0 (60HZ)	4	S06034-001	1-3-6	Sorting Cover	1	S05435-001
1-1-2	Vibrating Base Lower	1	S08480-001	1-3-7	Button With Control Plate	1	S07166-001
1-1-3	Vibrating Base Upper	1	S05912-101	1-3-8	Hingth Control Plate	1	S07165-001
1-1-4	Cushion Rubber	3	S05910-000	1-3-10	Spring Washer 2-4	11	028040-243
1-1-5	Screw 5X25	3	002502-505	1-3-11	Washer 4	7	025040-233
1-1-6	Spring Washer 2-5	3	028050-242	1-3-12	Bolt 5X14	1	018501-422
1-1-7	Washer 5	3	025050-232	1-3-13	Washer 5	1	025050-232
1-1-8	Vibrating Solenoid	1	S05914-101	1-3-14	Shooter Coil Supporter	1	S06022-001
1-1-9	Bolt	4	S08479-001	1-3-15	Alignment Plate (B)	1	S07164-001
1-1-11	Bolt 8X25	8	018082-522	1-3-16	Alignment Plate (C)	1	S07167-001
1-1-12	Washer	8	S05917-001	1-3-17	Washer 4	4	025040-332
1-1-13	Nut 8	4	021080-102	1-3-18	Screw 4X10	2	062401-006
1-1-19	Nut 6	12	021060-202	1-4	Screw	1	S05438-100
1-1-20	Spring Washer 2-6	8	028060-242	1-9	Spring Washer 2-8	1	028060-242
1-1-21	Base	1	S05907-101	1-10	Washer 8	1	025080-336
1-1-22	Spring Washer 2-8	8	028060-242	2	Shoot Coil Assembly (2.7X15)	1	S07042-001
1-1-24	Cord Holder	1	149547-000	3	Screw 3.57	1	S06441-001
1-1-25	Screw 4X8	1	062400-806	4	Bolt 6X63	2	144543-001
1-1-29	Cushion Collar	3	S06613-001	5	Washer	2	115947-001
1-3	Vibrating Ball Assembly	1	S06027-101	6	Spring Washer 2-6	2	028060-242
1-3-1	Vibrating Ball	1		7	Botton Sortor Cover Assembly	1	
1-3-2	Connector Assembly	1	S05428-001	8	Bolt 5X10	3	018501-022
1-3-2-1	Connector	1	S05429-001	9	Spring Washer 2-5	3	028050-242
1-3-2-2	Shooter Stop Pin	1	S05430-001	10	Washer 5	3	025050-232

F. Control box mechanism / Schaltkasten
 Mécanisme du boîtier de contrôle / Mecanismo del caja de controles

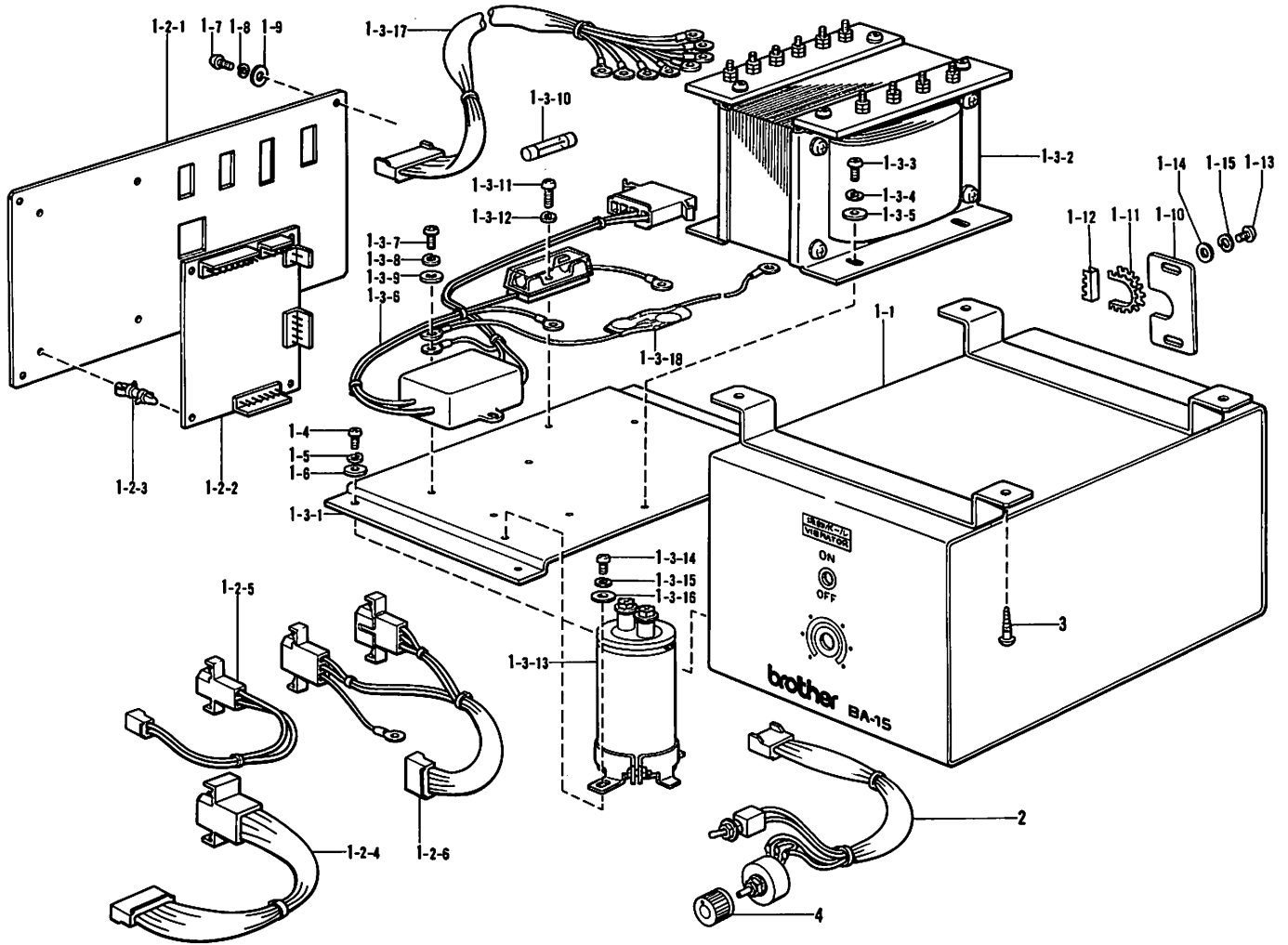

Ref.No.	Name of Parts	Q'ty	Parts No.	Ref.No.	Name of Parts	Q'ty	Parts No.
1	Box Assembly	1	S07058-001	1-3-13	Condenser C10B103	1	
1-1	Control Box Assembly	1		1-3-14	Screw 3X8	2	002300-803
1-2	Box Cover Assembly	1		1-3-15	Spring Washer 2-3	2	028030-243
1-2-1	Control Box Cover	1		1-3-16	Washer 3	2	025030-233
1-2-2	Printed Circuit Board	1	S05475-000	1-3-17	Trans Cable Assembly	1	
1-2-3	Support 6NS	4		1-3-18	Noise C Assembly	1	S12688-000
1-2-4	Cable (A) Assembly	1		1-4	Screw 4X8	4	062400-806
1-2-5	Cable (B) Assembly	1		1-5	Spring Washer 2-4	4	028040-243
1-2-6	Cable (E) Assembly	1		1-6	Washer 4	4	025040-233
1-3	Mount Plate Assembly	1		1-7	Screw 4X8	4	062400-806
1-3-1	Mount Plate	1		1-8	Spring Washer 2-4	4	028040-243
1-3-2	Trans (B)	1		1-9	Washer 4	4	025040-233
1-3-3	Screw 4X8	4	062400-806	1-10	Box Cover (B)	1	
1-3-4	Spring Washer 2-4	4	028040-243	1-11	Bush	1	
1-3-5	Washer 4	4	025040-233	1-12	Bush	1	
1-3-6	Noise Filter Assembly	1		1-13	Screw 4X8	2	062400-806
1-3-7	Screw 3X8	2	002300-803	1-14	Washer 4	2	025040-233
1-3-8	Spring Washer 2-3	2	028030-243	1-15	Spring Washer 2-4	2	028040-243
1-3-9	Washer 3	2	025030-232	2	Cable (D) Assembly	1	S05484-000
1-3-10	Fuse 3A	1	215769-001	3	Screw 4.5X25	4	032452-502
1-3-11	Screw 4X14	1	002401-403	4	Thumb	1	S02907-000
1-3-12	Spring Washer 2-4	1	028040-243				

G. Power supply equipment mechanism / Stromversorgung
Mécanisme de l'équipement en alimentation électrique / Mecanismo de la equipo de alimentación de corriente

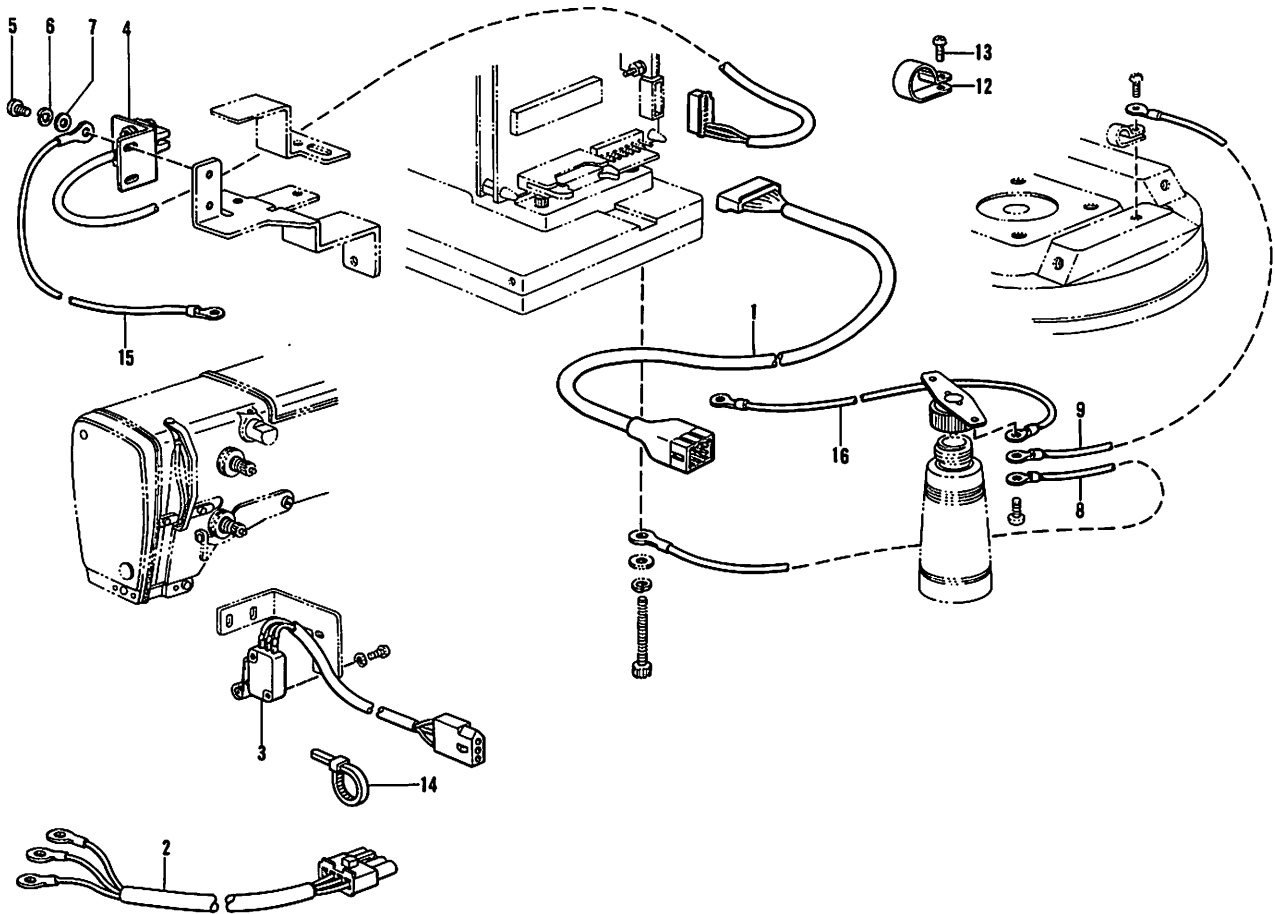

Ref.No.	Name of Parts	Q'ty	Parts No.	Ref.No.	Name of Parts	Q'ty	Parts No.
1	B Connection Cable Assembly	1	S05485-000	8	Cord (E)	1	S07984-000
2	Power Supply Cord Assembly	1	S06252-000	9	Cord (F)	1	S07985-000
3	Start Switch Assembly	1	S05488-000	10	Screw 4.5X25	2	032452-502
4	Sewing Machine Switch Assembly	1	S07104-001	14	Band PLTIM	6	S04557-000
5	Screw 3X8	2	002300-803	15	Cord (G)	1	S07986-000
6	Spring Washer 2-3	2	028030-243	16	Cord (H)	1	S10699-000
7	Washer 3	2	025030-233				

OPTION PARTS / SONDERZUBEHÖR
RIEZAS OPCION / PIECES EN OPTION

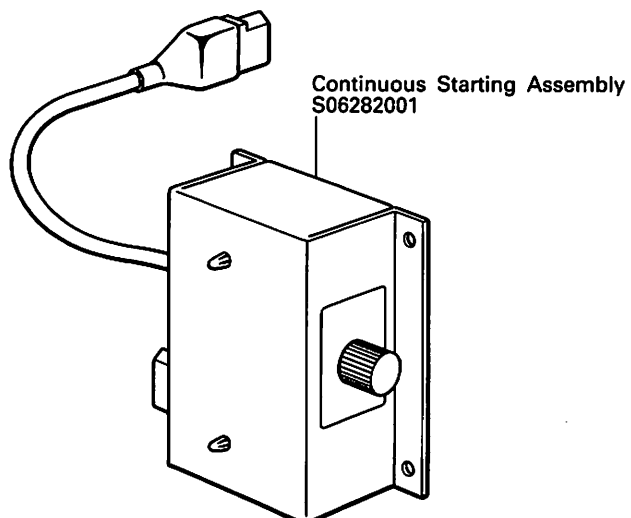

Z. Accessories / Zubehör
Accessoires / Accesorios

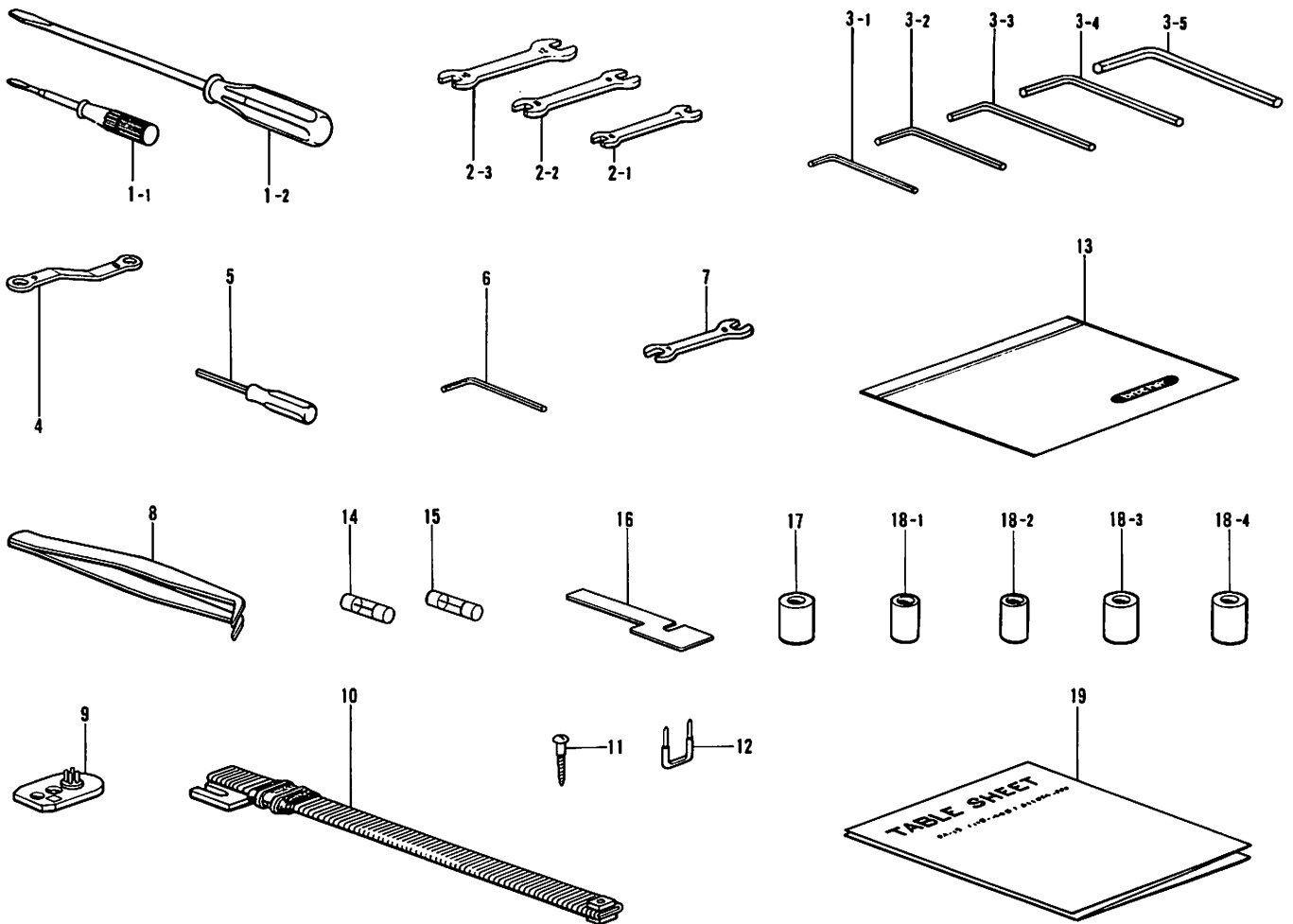

Ref.No.	Name of Parts	Q'ty	Parts No.
1-1	Screw Driver 3.4X70	1	118837-001
1-2	Screw Driver 5.5X190	1	101572-101
2-1	Spanner 6X7	1	107779-001
2-2	Spanner 8X9	1	100887-001
2-3	Spanner 10X12	1	107780-001
3-1	Spanner 2	1	142002-001
3-2	Spanner 3	1	142721-001
3-3	Spanner 4	1	118064-001
3-4	Spanner 5	1	150335-001
3-5	Spanner 6	1	115157-001
4	Wrench 8X9	1	105343-001
5	Screw Driver 1.6	1	S01943-001
6	Spanner 2.3	1	154125-001
7	Spanner 7X8	1	142205-001
8	Tweezers	1	117466-000

Ref.No.	Name of Parts	Q'ty	Parts No.
9	Button Catch Plate Assembly (WS)	1	S06687-003
10	Shooter Coil Assembly	1	S07042-002
11	Screw 4.25X25	2	032452-502
12	Staple	6	200190-001
13	Accessory Bag	1	122991-001
14	Fuse 3A	2	215769-001
15	G Fuse 4A	1	S06120-000
16	Spacer A (0.4mm)	2	S09604-000
16	Spacer B (0.8mm)	1	S09605-000
17	Gauge	1	S06620-001
18-1	Button Presser A	1	S05356-000
18-2	Button Presser B	1	S06569-000
18-3	Button Presser D	1	S09351-000
18-4	Button Presser E	1	S09352-000
19	Table Sheet	1	S11074-000

※ The details of included accessories are subject to change.

※ Les détails des accessoires inclus sont sujets à des changements.

※ Änderungen in der Aufstellung der mitgelieferten Zubehöre sind vorbehalten

※ Los detalles de los accesorios incluidos pueden variar.

GAUGE PARTS LIST / LEHRENLISTE
 LISTE DES PIÈCES D'ECARTEMENT / LISTA DE PIEZAS CALIBRADORAS

Button Catch Plate Assembly

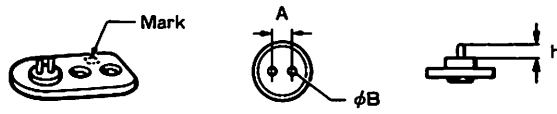

Mark	A(mm)	ϕB (mm)	h(mm)	Parts. No.
C	2.6	1.0	4	S06686-001
D	2.8	1.2	4	S06686-002
E	3.0	1.2	4	S06686-003
F	3.2	1.2	4	S06686-004
G	3.4	1.2	4	S06686-005
H	3.6	1.2	4	S06686-006
J	3.8	1.2	4	S06686-007
K	3.2	1.5	4	S06686-008
L	3.4	1.5	4	S06686-009
M	3.6	1.5	4	S06686-010
N	3.8	1.5	4	S06686-011

Button Catch Plate Assembly W

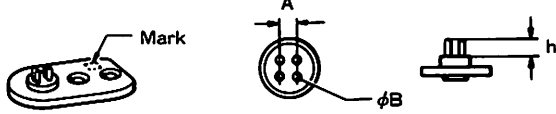



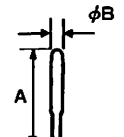

Mark	A(mm)	ϕB (mm)	h(mm)	Parts. No.
D	2.2	1.0	4	S06687-001
E	2.4	1.0	4	S06687-002
F	2.6	1.2	4	S06687-003
G	2.8	1.2	4	S06687-004
H	3.0	1.2	4	S06687-005
J	3.2	1.2	4	S06708-001
K	3.4	1.5	4	S06708-002
L	3.6	1.5	4	S06708-003
M	3.2	1.5	4	S06708-004

Pin

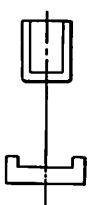

A(mm)	ϕB (mm)	Parts. No.
9	1.0	S06688-001
9	1.2	S06689-001
9	1.5	S06690-001

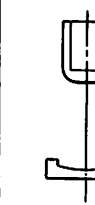
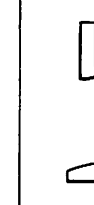
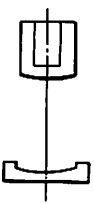
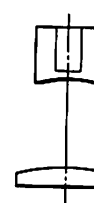
Button Presser

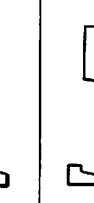
S05356-000	S06569-000	S06570-000	S09351-000	
Accessory (A)	Standard (B)	Standard (C)	Accessory (D)	
				
$\phi 8$	$\phi 8$	$\phi 8$	$\phi 10$	
S09352-000	S09353-000	S09354-000	S09355-000	S09356-000
Accessory (E)	Option(F)	Option(G)	Option(H)	Option(J)
				
$\phi 10$	$\phi 12$	$\phi 12$	$\phi 16$	$\phi 16$

Gaugi

S06620-001

Button Upper Cover

Mark	ϕA (mm)	Parts. No.
A	9 ~ 17	S09601-100
B	12 ~ 17	S09602-100
C	16 ~ 22	S09603-100

Shoot Coil Assembly

Mark	A(mm) × B(mm)	Parts. No.
A	15 × 2.7	S07042-001
B	17 × 3.5	S07042-002
C	25 × 4.0	S07042-003
D	13 × 2.5	S07042-004
E	13 × 3.0	S07042-005
F	15 × 3.2	S07042-006
G	15 × 3.8	S07042-007
H	17 × 4.0	S07042-008
J	18 × 4.5	S07042-009
K	20 × 3.5	S07042-010
L	20 × 4.0	S07042-011
M	21 × 4.5	S07042-012
N	22 × 5.7	S07042-013
P	25 × 4.7	S07042-014
Q	13 × 2.0	S07042-015
R	22 × 2.0	S07042-016
S	17 × 2.7	S07042-017
T	17 × 2.2	S07042-018

Spacer

Mark	t (mm)	Parts. No.
A	0.4	S09604-000
B	0.8	S09605-000

Button Catch Plate Blank

		A(mm)	Parts. No.
		6	S06133-001
		8.5	S06710-001

Sorting Plate

S05433-000	(U) S06814-001	(UB) S06816-000	(M) S06815-000

INDEX/VERZEICHNIS
INDEX/INDICE

部品コード Parts No.	参照番号 Ref. No.	部品コード Parts No.	参照番号 Ref. No.	部品コード Parts No.	参照番号 Ref. No.	部品コード Parts No.	参照番号 Ref. No.
S00554-000	C- 1-200	S05394-001	C- 1-138	S07042-001	E- 2	S09579-001	C- 1-243
S01696-001	C- 1-139	S05397-001	C- 1-142	S07042-002	Z- 10	S09581-001	C- 1-242
	C- 1-143	S05421-001	C- 1-177	S07051-000	C- 1-8-1	S09582-001	C- 1-226
S01943-001	Z- 5	S05424-001	C- 1-185	S07052-001	C- 1-8-2	S09584-001	C- 1-250
S02592-001	B- 1-17	S05426-101	E- 1	S07053-001	C- 1-8-7	S09585-001	C- 1-252
S02745-001	B- 1-15	S05426-102	E- 1	S07054-001	C- 1-8-10	S09586-001	C- 1-257
S02907-000	F- 4	S05427-101	E- 1-1	S07055-001	B- 1-6	S09587-001	C- 1-231
S03464-101	A- 4-2-1	S05427-102	E- 1-1	S07056-001	C- 1-197	S09590-001	C- 1-239
S03468-001	A- 4-2-13	S05428-001	E- 1-3-2	S07058-001	F- 1	S09591-000	C- 1-225
S03600-001	A- 4-5	S05429-001	E- 1-3-2-1	S07060-001	C- 2	S09592-001	C- 1-229
S03606-001	A- 4-10	S05430-001	E- 1-3-2-2	S07061-001	C- 1-002	S09593-001	C- 1-230
S03607-001	A- 4-11	S05431-001	E- 1-3-2-3	S07062-001	C- 1-001-1-3	S09594-001	C- 1-238
S03608-001	A- 4-12	S05433-000	E- 1-3-5	S07064-001	C- 1-001-3	S09596-001	C- 1-223
S03610-001	A- 4-2-15	S05435-001	E- 1-3-6	S07065-001	C- 1-001-1	S09597-001	C- 1-223-1
S03657-001	A- 4-2-14	S05438-100	E- 1-4	S07067-001	C- 1-001	S09598-001	C- 1-223-2
	C- 1-3-1-13	S05475-000	F- 1-2-2	S07069-001	C- 1-241	S09599-000	C- 1-224
	C- 20	S05484-000	F- 2	S07070-001	C- 1-037	S09600-001	C- 1-220
S04557-000	G- 14	S05485-000	G- 1	S07071-001	C- 1-026	S09601-100	C- 1-249
	C- 1-198	S05488-000	G- 3	S07072-001	C- 1-025	S09604-000	C- 16
	C- 1-199	S05678-101	A- 4-2-4	S07073-001	C- 1-020	S09605-000	Z- 16
S05326-000	C- 12	S05679-101	A- 4-2-2	S07074-001	C- 1-080		C- 16
S05329-000	C- 1-038	S05680-101	A- 4-2-3	S07075-001	C- 1-127		Z- 16
S05330-000	C- 1-039	S05681-101	A- 4-2-5	S07076-001	C- 1-136	S09609-001	C- 1-186
S05331-000	C- 1-040	S05687-001	A- 4-2-10	S07079-001	A- 4-6	S09611-000	C- 1-266
S05332-000	C- 1-042	S05729-001	C- 1-3-1-5	S07080-001	A- 4	S09613-001	C- 1-273
S05333-001	C- 1-044	S05730-001	C- 1-3-2	S07081-001	A- 4-1	S09636-001	B- 1-3
S05334-000	C- 1-052	S05731-001	C- 1-3-3	S07091-001	C- 1-233	S09637-001	B- 1-4
S05335-001	C- 1-054	S05734-001	C- 1-3-4	S07092-001	A- 9	S10504-001	C- 3
S05336-001	C- 1-118	S05738-001	C- 1-207	S07093-001	A- 8	S10512-001	C- 1-168
S05337-000	C- 1-055	S05881-001	B- 2	S07098-001	A- 4-13	S10549-000	B- 1-1
S05338-000	C- 1-057	S05882-001	B- 5	S07099-001	B- 1-20	S10699-000	G- 16
S05339-001	C- 1-058	S05884-000	B- 6	S07102-001	C- 1	S10701-001	C- 1-068
S05340-001	C- 1-060	S05888-001	C- 1-189	S07104-001	G- 4	S10703-000	C- 1-069
S05341-001	C- 1-061	S05889-001	C- 1-190	S07105-001	D- 1	S10704-001	C- 1-075
	C- 1-093	S05905-001	A- 4-2-11	S07107-001	A- 5	S10705-000	C- 1-073
	C- 1-096	S05907-101	E- 1-1-21	S07108-001	B- 1	S10706-000	C- 1-074
	C- 1-107	S05910-000	E- 1-1-4	S07110-001	C- 1-006	S10707-001	C- 1-077
S05342-001	C- 1-062	S05912-101	E- 1-1-3	S07117-001	A- 4-14	S10708-001	C- 1-076
S05343-000	C- 1-063	S05914-101	E- 1-1-8	S07122-001	B- 1-21	S10709-001	C- 1-072
S05344-000	C- 1-065	S05917-001	E- 1-1-12	S07127-001	C- 1-8-12	S10779-001	A- 4-2
S05345-001	C- 1-066	S05972-000	C- 1-098	S07128-001	C- 1-124	S11073-000	B- 1-10
S05356-000	Z- 18-1	S05973-001	B- 15	S07129-001	C- 1-125	S11074-000	Z- 19
S05359-001	C- 1-085	S06022-001	E- 1-3-14	S07136-001	C- 1-3-1	S12415-001	C- 1-130
S05363-001	C- 1-086	S06024-001	C- 1-050	S07137-001	C- 1-3	S12416-000	C- 1-203
S05364-001	C- 1-088	S06027-101	E- 1-3	S07138-001	B- 10	S12688-000	F- 1-3-18
S05365-001	C- 1-092	S06029-001	C- 1-051	S07163-001	E- 1-3-4	S12694-001	A- 3
S05367-001	C- 1-095	S06033-001	E- 1-1-1	S07164-001	E- 1-3-15	002300-502	C- 1-071
S05368-101	C- 1-099	S06034-001	E- 1-1-1	S07165-001	E- 1-3-8	002300-603	B- 1-12
S05369-001	C- 1-101	S06044-001	C- 1-129	S07166-001	E- 1-3-7	002300-803	C- 1-3-1-5-2
S05370-001	C- 1-102	S06119-001	C- 1-134	S07167-001	E- 1-3-16		C- 1-083
S05371-001	C- 1-022	S06120-000	Z- 15	S07172-001	B- 17		C- 1-178
	C- 1-106	S06252-000	G- 2	S07979-001	A- 1		C- 1-3-1-10
	C- 1-8-3	S06441-001	E- 3	S07984-000	G- 8		C- 1-3-3-3
S05373-001	C- 1-113	S06569-000	Z- 18-2	S07985-000	G- 9		D- 1-3
S05375-001	C- 1-120	S06570-000	C- 1-079	S07986-000	G- 15		F- 1-3-7
S05376-001	C- 1-122	S06613-001	E- 1-1-29	S08479-001	E- 1-1-9		F- 1-3-14
S05378-000	C- 1-001-1-1	S06620-001	Z- 17	S08480-001	E- 1-1-2		G- 5
S05379-000	C- 1-001-1-2	S06671-001	C- 1-194	S09351-000	Z- 18-3		002301-003
S05384-001	C- 1-017	S06686-004	C- 1-3-5	S09352-000	Z- 18-4	C- 1-3-4-3	
S05385-000	C- 1-019	S06687-003	Z- 9	S09572-001	C- 1-264	002301-603	B- 13
S05387-001	C- 1-021	S06992-001	A- 4-17	S09573-001	C- 1-262	002350-806	C- 1-097
S05388-001	C- 1-023	S06994-001	A- 4-7	S09574-001	C- 1-240	002400-663	B- 1-16
S05388-001	C- 1-8-4	S06995-001	A- 5-1	S09575-001	C- 1-261	002401-402	B- 7
S05391-001	C- 1-031	S06996-001	A- 5-3	S09576-001	C- 1-248	002401-403	F- 1-3-11
	C- 1-8-9	S06997-001	A- 5-8	S09577-001	C- 1-247	002502-505	E- 1-1-5
S05392-001	B- 1-22	S06998-001	A- 5-2	S09578-001	C- 1-227	007301-212	C- 1-029

部品コード Parts No.	参照番号 Ref. No.	部品コード Parts No.	参照番号 Ref. No.	部品コード Parts No.	参照番号 Ref. No.	部品コード Parts No.	参照番号 Ref. No.	
014060-622	C- 1-028	025030-233	C- 1-179	028040-243	F- 1-8	141334-001	C- 1-121	
	C- 1-126		C- 1-3-1-9		F- 1-15		C- 1-187	
	C- 1-271		C- 1-3-1-12	028050-242	C- 1-013	C- 1-8-8		
	C- 1-8-11		F- 1-3-16		C- 1-237	142002-001	Z- 3-1	
014060-632	B- 1-23	025040-232	G- 7	028060-242	C- 1-3-10	142205-001	Z- 7	
	C- 1-018		B- 1-19		E- 1-1-6	142268-001	B- 1-11	
	C- 1-034		B- 9		E- 9	142721-001	Z- 3-2	
	C- 1-041		C- 1-048		C- 8	144526-001	A- 10	
	C- 1-045		C- 1-091	E- 1-1-20	144543-001	E- 4		
	C- 1-100		C- 1-115	E- 6	146354-001	A- 4-4		
	C- 1-105		C- 1-182	B- 1-8	148417-001	A- 11		
	C- 1-123		C- 1-211	E- 1-1-22	148546-001	C- 1-094		
	C- 1-128		C- 1-246	E- 1-9	148587-001	C- 1-111		
	014300-432		C- 1-053	025040-233	C- 1-254	032452-502	F- 3	148589-001
C- 1-056		C- 1-259	G- 10		148592-001		C- 1-119	
C- 1-059		C- 5	Z- 11		149073-001		C- 1-212	
C- 1-070		D- 4	A- 4-2-8		149127-001		A- 4-18	
014300-522	C- 1-3-1-4	025040-233	C- 1-206	047250-642	C- 1-228	149547-000	E- 1-1-24	
014400-522	C- 1-078		E- 1-3-11	048020-342	C- 1-5	150335-001	Z- 3-4	
	C- 1-272		F- 1-3-5	048025-342	C- 1-263	150554-002	B- 4	
014500-522	C- 1-024		F- 1-6		F- 1-9	E- 1-3-2-4	150556-001	A- 4-15
	C- 1-043	F- 1-9	048030-342	C- 1-232	150556-001	A- 4-8		
	C- 1-064	F- 1-14		C- 1-269	152877-001	C- 1-234		
	C- 1-067	E- 1-3-17	048040-342	B- 1-5	153484-001	A- 5-5		
014760-622	A- 5-7	025050-232	C- 1-012	048060-342	C- 1-104	154125-001	C- 1-005	
			C- 1-270	C- 1-146	B- 1-24		Z- 6	
	C- 1-8-6		C- 1-236	061500-804	C- 1-251	155571-001	A- 7	
	014760-622		A- 6	C- 1-268	062260-406	C- 1-267	158998-001	B- 3
C- 1-135		E- 1-1-7	062400-616	C- 1-191	159394-001	B- 18		
017062-003	C- 1-003	025060-232	E- 1-3-13	062400-806	C- 1-202	200190-001	Z- 12	
017501-602	C- 1-145		E- 10		C- 4	215769-001	F- 1-3-10	
017711-412	A- 2		C- 1-004		C- 1-004	E- 1-1-25		Z- 14
	A- 4-3		E- 1-10		E- 1-10	E- 1-3-3		
018051-622	C- 1-235	025080-336	B- 1-25	F- 1-3-3				
018061-222	B- 1-7	025100-132	A- 4-16	F- 1-4				
018062-022	C- 1-001-2	025680-232	B- 1-13	F- 1-7				
018065-022	C- 6	028030-242	C- 1-084	F- 1-13				
018082-522	E- 1-1-11	028030-243	B- 14	062401-006	E- 1-3-18			
018300-822	C- 1-265		C- 1-3-1-7	062670-512	C- 1-274			
018400-822	C- 1-244		C- 1-3-1-11	062680-512	A- 4-2-7			
	C- 1-253		C- 1-3-3-4	062680-812	A- 4-2-12			
018400-832	C- 1-258	C- 1-3-4-4	100022-005	C- 1-112				
	B- 1-18	D- 1-4	100887-001	Z- 2-2				
	B- 11	F- 1-3-8	101125-000	B- 16				
	C- 1-209	F- 1-3-15	101572-101	Z- 1-2				
018401-022	D- 2	G- 6	102630-001	B- 1-9				
	C- 1-007	B- 8	105234-003	A- 5-6				
	C- 1-008	B- 12		C- 1-027				
	C- 1-047	C- 1-010	105343-001	Z- 4				
	C- 1-081	C- 1-049	107744-001	A- 5-4				
	C- 1-089	C- 1-090	107779-001	Z- 2-1				
018501-022	C- 1-181	C- 1-116	107780-001	Z- 2-3				
	C- 1-222	C- 1-183	110367-001	C- 1-103				
018501-222	E- 8	C- 1-193	115156-001	A- 4-2-6				
018501-422	C- 1-011	C- 1-210	115157-001	Z- 3-5				
	C- 1-8-5	C- 1-221	115158-001	A- 4-2-9				
021060-106	E- 1-3-12	C- 1-245	115166-001	A- 4-9				
021060-202	C- 1-131	C- 1-255	115544-001	B- 19				
021080-102	E- 1-1-19	C- 1-260	115947-001	C- 7				
021080-102	E- 1-1-13	D- 3		E- 5				
021080-302	B- 1-2	C- 1-201	117466-000	Z- 8				
021300-103	C- 1-030	C- 21	118064-001	Z- 3-3				
	C- 1-3-1-8	E- 1-3-10	118837-001	Z- 1-1				
021400-202	C- 1-108	F- 1-3-4	122991-001	Z- 13				
	C- 1-114	F- 1-3-12	141334-001	C- 1-032				
025030-232	F- 1-3-9	F- 1-5		C- 1-087				

