

brother

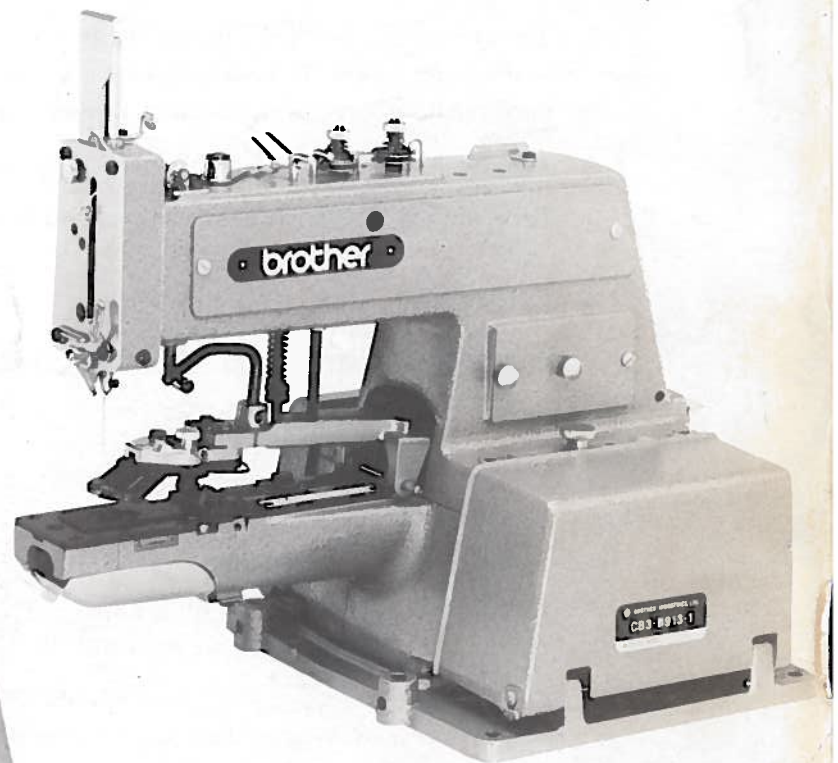
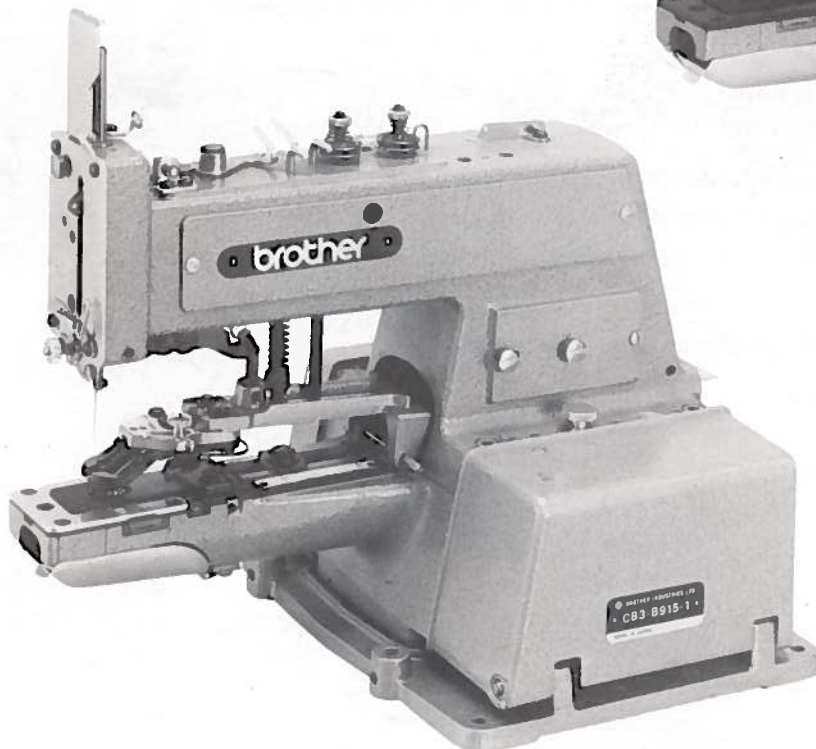

Single-chain stitch buttoning machine
Knopfnähmaschine für Einfachkettenstitch
Machine à boutonner à point chaînette simple
Máquina de coser botones de punto de cadeneta simple

CB3-B913
CB3-B915

PARTS BOOK
TEILEKATALOG
LIVRE DES PIECES
LIBRO DE REFERENCIA DE PIEZAS





Notes for using this parts book

1. This book is for model CB3-B913 single-chain stitch buttoner and for model CB3-B915 single chain stitch buttoner with automatic thread trimmer.
2. If the symbol  is found in the "Parts No." column or the "Assembly No." column, refer to the different parts list on page 11.
3. The symbol  in the "Parts No." column indicates that the parts is not available for supply. If, however, there is a number in the "Assembly No." column, the parts can be ordered as an assembly. Please, therefore, order by using the assembly No.
4. This book was prepared based on information available in January, 1984.
5. Parts are subject to changes in design without prior notice.

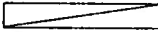

Anmerkungen zum Gebrauch dieses Stücklistebuches

1. Diese Bedienungsanleitung ist für das Modell CB3-B913, Knopfnähmaschine für Einfachkettenstich und für das Modell CB3-B915, Knopfnähmaschine für Einfachkettenstich mit automatischem Fadenabschneider.
2. Dieses Zeichen  in der Spalte "Parts No. (Teilnummer)" oder "Assembly No. (Gerätesatznummer)" verweist auf die Gesonderte Stückliste auf Seite 11.
3. Dieses Zeichen  in der Spalte "Teilnummer" bedeutet, daß dieser Teil nicht lieferbar ist. Wenn jedoch in der Spalte "Gerätesatznummer" eine Nummer steht, kann dieser Teil als ein Geräteteilsatz bestellt werden. Bestellen Sie daher bitte mit dieser Gerätesatznummer.
4. Dieses Buch basiert auf den Informationen vom Januar, 1984.
5. Modelländerungen sind vorbehalten.

Notes sur l'utilisation de ce manuel de pièces détachées

1. Ce manuel s'applique à la boutonnière à interrupteur à point de chaînette simple modèle no. CB3-B913 et à la boutonnière à interrupteur à point de chaînette simple modèle no. CB3-B915, avec coupe-fils automatique.
2. Si le symbole  se trouve dans la colonne "Parts No. (N° de pièce)" ou dans la colonne "Assembly No. (N° jeu de pces)", veuillez vous référer à la liste de pièces annexe page 11.
3. Le symbole  dans la colonne "N° de pièce" signifie que la pièce ne peut être fournie. Si, dans la colonne "N° jeu de pces", il y a un numéro de nomenclature, la pièce peut être commandée comme faisant partie d'un jeu de pièces. Donc, pour toute commande, veuillez spécifier le n° du jeu de pièces.
4. Ce manuel a été fait d'après les renseignements valables au mois de Janvier 1984.
5. Les pièces peuvent être sujettes à des modifications sans préavis.

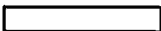
Notas para usar este Libro de Piezas

1. Este manual corresponde a la máquina de coser botones de punto de cadeneta simple modelo CB3-B913, y a la máquina de coser botones de punto de cadeneta simple provista de cortahilos automático modelo CB3-B915.
2. De haber un símbolo  junto al "Parts No. (Número de Pieza)" o en la columna del "Assembly No. (Número de Juego)", habrá que mirar la lista de piezas separada de la página 11.
3. El símbolo  , que se encuentra en la columna del "Número de Pieza", quiere decir que no se dispone de dicha pieza sola. Cuando, empero, hay un número en la columna del "Número de Juego", se podrá ordenar la pieza con todo el juego. Por lo tanto, será mejor hacer el pedido recurriendo al número del juego respectivo.
4. Este libro ha sido compilado basándose en los datos de que se disponía en enero de 1984.
5. Las piezas quedan sujetas a cambios de diseño sin aviso previo.

CONTENTS

A. Machine body	1
B. Driving clutch and brake mechanism	2
C. Needle bar and driving clutch mechanism	3
D. Loop spreading mechanism	3
E. Lower shaft mechanism	4
F. Stitch number conversion	4
G. Feed mechanism	5
H. Threading mechanism	6
J. Button clamp mechanism (B913)	7
K. Button clamp mechanism (B915)	8
L. Thread trimmer mechanism (B915)	9
Z. Accessories	10
Different parts list	11
Option	11
INDEX	13

INHALTSVERZEICHNIS

A. Maschinengehäuse	1
B. Antriebskupplung und stoppmechanismus	2
C. Nadelstange und Antriebskupplung	3
D. Schleifenzieher	3
E. Untere Welle	4
F. Stichzahlumrechnung	4
G. Transportvorrichtung	5
H. Fadenführungsvorrichtung	6
J. Knopfhaltevorrichtung (B913)	7
K. Knopfhaltevorrichtung (B915)	8
L. Fadenabschneidevorrichtung (B915)	9
Z. Zubehör	10
Zubehörliste	11
Option	11
VERZEICHNIS	13

TABLE DES MATIERES

A.	Corps de la machine	1
B.	Embrayage d'entraînement et mécanisme d'arrêt	2
C.	Barre à aiguille et mécanisme d'embrayage d'entraînement	3
D.	Etirement de boucle	3
E.	Mécanisme de l'arbre inférieur	4
F.	Conversion de nombre de points	4
G.	Mécanisme de l'entraînement	5
H.	Mécanisme de jénfilage	6
J.	Mécanisme du pince-boutons (B913)	7
K.	Mécanisme du pince-boutons (B915)	8
L.	Mécanisme de coupe-fill (B915)	9
Z.	Accessoires	10
	Liste des pièces accessoires	11
	Option	11
	INDEX	13

INDICE

A.	Denominación del mecanismo	1
B.	Embrague de mando y mecanismo de detención	2
C.	Barra de aguja y mecanismo de embrague de mando	3
D.	Ensanche de bucle	3
E.	Mécanisme de la eje inferior	4
F.	Conversión de número de puntadas	4
G.	Mécanisme de la alimentación	5
H.	Mécanisme de la enhebrado	6
J.	Mécanisme de la ménsula del botón (B913)	7
K.	Mécanisme de la ménsula del botón (B915)	8
L.	Mécanisme de recortadora de orillos (B915)	9
Z.	Accesorios	10
	Lista de piezas accesorias	11
	Opción	11
	INDICE	13

A. Machine body / Maschinengehäuse
 Corps de la machine / Denominación del mecanismo

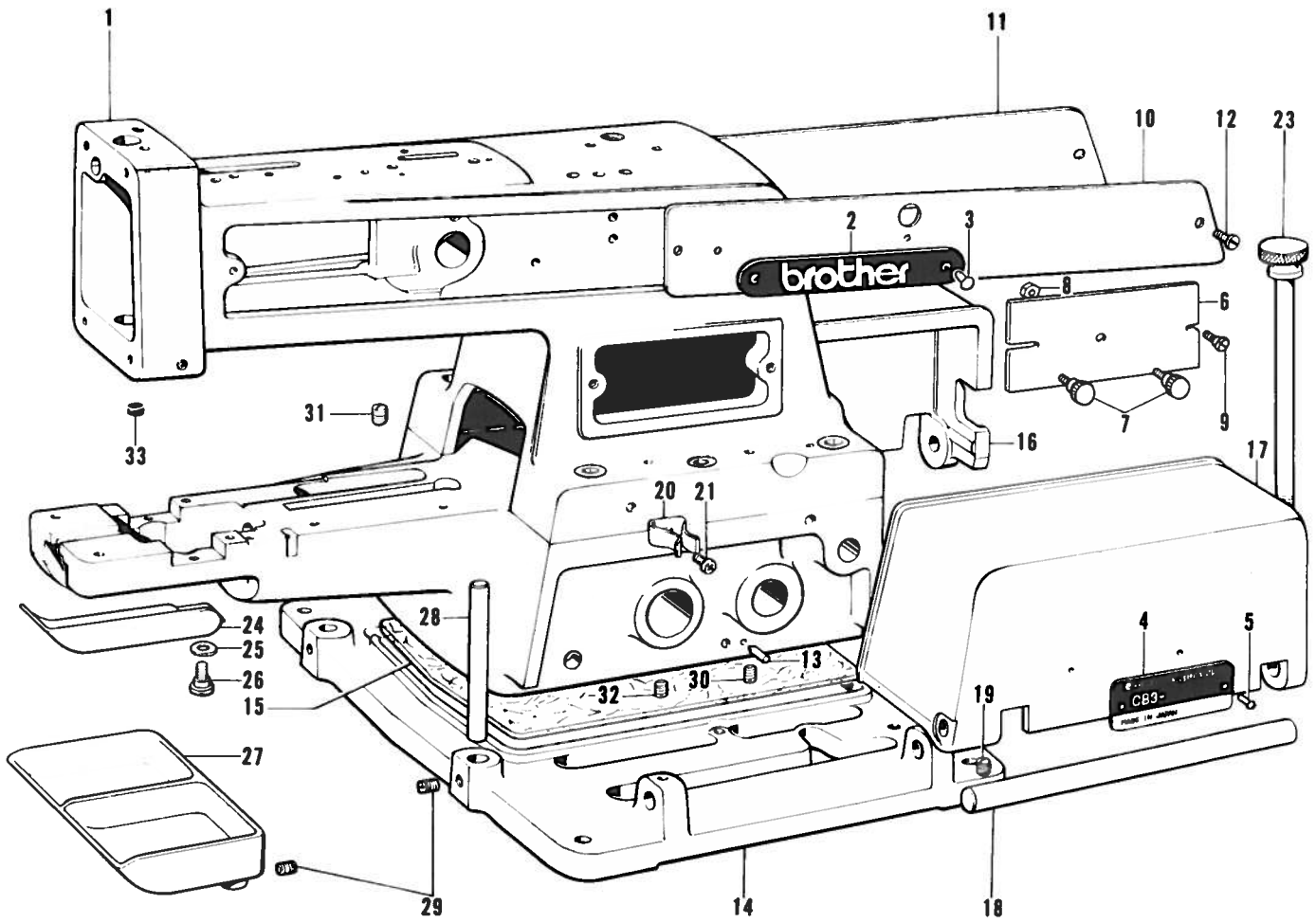

Ref. No.	Name of Parts	Q'ty	Parts No.	Assembly No.	Ref. No	Name of Parts	Q'ty	Parts No.	Assembly No.
1	Arm Bed	1			17	Bed Cover Assembly (Right)	1	154224-003	
2	Name Plate	2			18	Bed Cover Shaft	2	114984-000	
3	Pin	4			19	Screw 5.56 x 6	1	013750-610	
4	Model Plate	1			20	Bed Cover Stop Spring	2	114985-001	
5	Pin	2			21	Screw 437-40 x 7	2	062680-712	
6	Rear Cover	1	114976-003		23	Bolt	1	114986-001	
7	Screw 3.57	2	129986-001		24	Looper Cover	1	115275-001	
8	Nut 3.57	1	021670-202		25	Washer	1	105329-001	
9	Stud Screw 3.57	1	114977-001		26	Stud Screw 4.37	1	114988-001	
10	Arm Cover (Right)	1	114978-103		27	Button Tray	1	115270-003	
11	Arm Cover (Left)	1	114979-103		28	Button Tray Leg	2	115160-001	
12	Screw 4.37	4	106629-002		29	Screw 6.35	4	013770-610	
13	Pin	2	114980-001		30	Screw 4.76 x 10	2	013711-010	
14	Bed Base	1			31	Screw 5.56 x 10	1	013751-010	
15	Felt	1	114982-000		32	Screw 4.76 x 10	2	013711-010	
16	Bed Cover Assembly (Left)	1	154225-003		33	Oil Cap	1	110104-000	

B. Driving clutch and brake mechanism / Antriebskupplung und Stopmechanismus
 Embrayage d'entraînement et mécanisme d'arrêt / Embrague de mando y mecanismo de detención

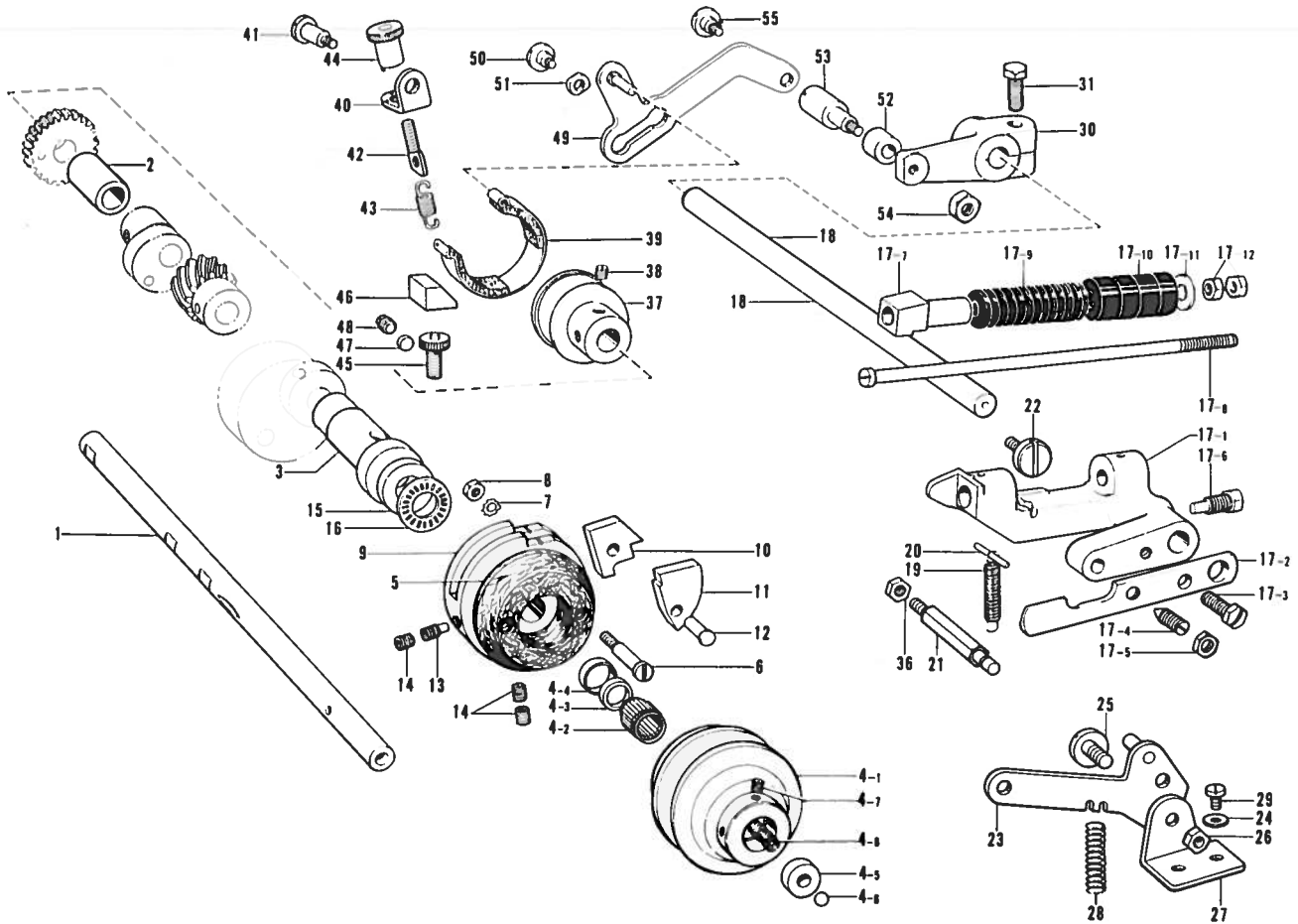

Ref. No.	Name of Parts	Q'ty	Parts No.	Assembly No.	Ref. No.	Name of Parts	Q'ty	Parts No.	Assembly No.
1	Driving Shaft	1	114989-001		17-12	Nut 7.14	2	021800-102	B-17 144747-201
2	Bushing (Left)	1	115215-000		18	Clutch Body Shaft	1	115013-001	
3	Bushing (Right)	1	115214-100		19	Spring	1	115020-001	
4- 1	Pulley	1	114991-001	B-4 Pulley Assembly 114990-001	20	Pin	1	115021-001	
4- 2	Bearing	2	114992-000		21	Spring Hanger	1	115022-001	
4- 3	Grease Seal	1	114993-000		22	Screw 5.56	1	115268-002	
4- 4	Grease Seal Cap	1	114994-001		23	Clutch Driving Lever	1	142307-001	
4- 5	Ball Holder	1	114995-001		24	Washer 4.76	2	025710-232	
4- 6	Steel Ball 5/16	1	071079-450		25	Screw 5.56	1	115268-002	
4- 7	Screw 4.76	2	013710-712		26	Nut 5.56	1	021750-102	
4- 8	Spring	1	114997-001		27	Clutch Drive Lever Plate	1	115025-001	
5	Clutch Plate	1	114998-000	28	Spring	1	115026-001		
6	Screw 5.56	2	114999-001	29	Screw 476-32 x 12	2	062711-212		
7	Washer	2	115000-000	30	Stitch Regulating Lever	1	115027-101		
8	Nut 5.56	2	021750-102	31	Bolt 7.94 x 22	1	017822-212		
9	Stop Cam (for B913)	1	149995-001	36	Nut 4.37	1	102571-003		
	Stop Cam (for B915)	1	153542-001	37	Brake Drum	1	144509-000		
10	Brake Cam Segment	1	115002-101	38	Screw 5.56 x 6	2	013750-610		
11	Flange Cam Segment	1	115003-001	39	Brake Shoe Assembly	1	144510-001		
12	Pin	2	115004-001	40	Brake Spring Plate	1	144513-001		
13	Set Screw	1	149996-001	41	Stud Screw 4.76	1	144514-001		
14	Screw 7.95 x 10	3	014821-022	42	Spring Hook	1	144515-001		
15	Washer	1	115007-001	43	Spring	1	144516-001		
16	Thrust Bearing	1	115008-000	44	Screw	1	144517-001		
17- 1	Clutch Body	1		45	Brake Adjuster Knob	1	144518-001		
17- 2	Ball Presser Plate	1	115010-001	46	Brake Adjuster	1	144519-001		
17- 3	Bolt 6.35	1	115011-001	47	Washer	1	107793-000		
17- 4	Screw 6.35	1	115012-002	48	Screw 5.95	1	151604-001		
17- 5	Nut 6.35	1	150554-002	49	Brake Lever	1	144520-001		
17- 6	Set Screw	1	115014-001	50	Stud Screw 4.76	1	144523-001		
17- 7	Stopper Bracket	1	115015-101	51	Slide Block	1	144524-000		
17- 8	Stopper Shaft	1	115016-001	52	Roller	1	105872-101		
17- 9	Washer	31	115017-001	53	Stud	1	144525-001		
17-10	Cushion Rubber	4	115018-001	54	Nut 4.76	1	110161-004		
17-11	Washer 7.14	1	025800-332	55	Stud Screw 4.37	1	144526-001		

C. Needle bar and driving clutch mechanism / Nadelstange und Antriebskupplung
 Barre à aiguille et mécanisme d'embrayage d'entraînement / Barra de aguja y mecanismo de embrague de mando

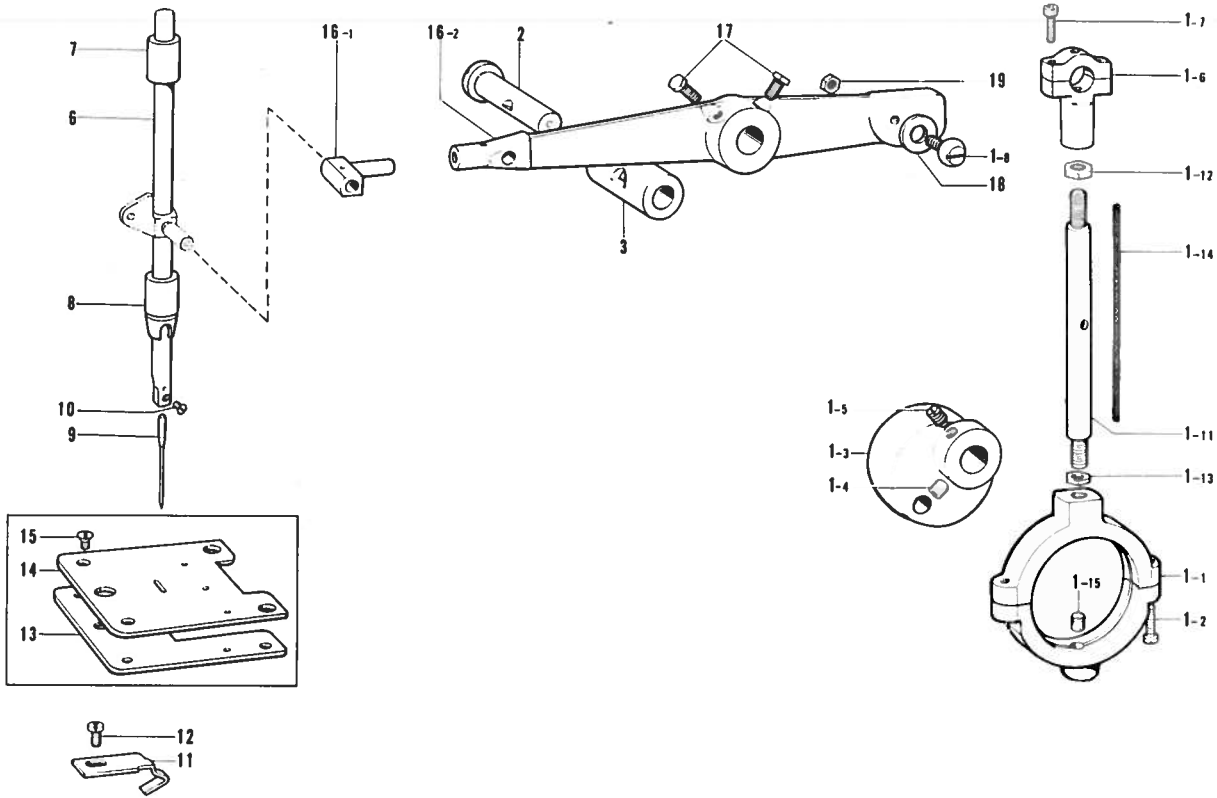

Ref. No.	Name of Parts	Q'ty	Parts No.	Assembly No.	Ref. No.	Name of Parts	Q'ty	Parts No.	Assembly No.
1- 1	Lower Crank Rod	1		C-1 Crank Rod Assembly 144700-101	7	Needle Bar Bushing (Upper)	1	115051-000	
1- 2	Screw 4.37	2	142658-001		8	Needle Bar Bushing (Lower)	1	115052-000	
1- 3	Needle Bar Driving Cam	1			9	Needle TO x 1 #16	1	115053-016	
1- 4	Screw 6.35 x 6	1	014770-622		10	Screw 3.18	1	140553-102	
1- 5	Screw 6.35	1	015770-812		11	Needle Guide	1	115054-101	
1- 6	Upper Crank Rod	1			12	Screw 476-32 x 7	1	062710-712	
1- 7	Screw 4.37 x 14	2	148425-002		13	Needle Plate Subordinate (for B913)	1	115055-001	
1- 8	Round Joint	1			14	Needle Plate (for B913)	1	144711-001	
1-11	Crank Rod	1	115041-001		15	Screw 4.37 x 10 (for B913)	4	S01702-001	
1-12	Nut 7.14	1	021800-102		16- 1	Needle Bar Bracket	1	115048-001	C-16 Needle Bar Driving Lever Assembly 182350-001
1-13	Nut 7.14	1	115042-001		16- 2	Needle Bar Driving Lever	1		
1-14	Wick	1	144701-000		17	Bolt 5.56 x 14	2	017751-412	
1-15	Felt	1	107155-001		18	Washer	1	144657-000	
2	Needle Bar Driving Lever Shaft	1	115046-001		19	Nut 5.56	1	021750-102	
3	Bushing	1	115047-001						
6	Needle Bar	1	115050-001						

D. Loop spreading mechanism / Schleifenzieher
 Etirement de boucle / Ensanche de boucle

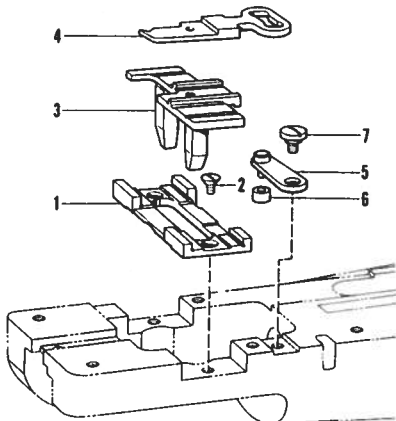

Ref. No.	Name of Parts	Q'ty	Parts No.	Assembly No.
1	Thread Handler Bracket	1	151991-000	
2	Screw 3.57 x 6	2	S01696-001	
3	Thread Handler Guide Plate (for B913)	1	115071-001	
	Thread Handler Guide Plate (for B915)	1	151992-001	
4	Thread Handler (for B913)	1	115072-001	
	Thread Handler (for B915)	1	151993-001	
5	Thread Handler Link	1	115073-001	
6	Thread Handler Link Roller	1	115076-001	
7	Stud Screw 4.76	1	115077-001	

E. Lower shaft mechanism / Untere Welle
Mécanisme de l'arbre inférieur / Mecanismo de la eje inferior

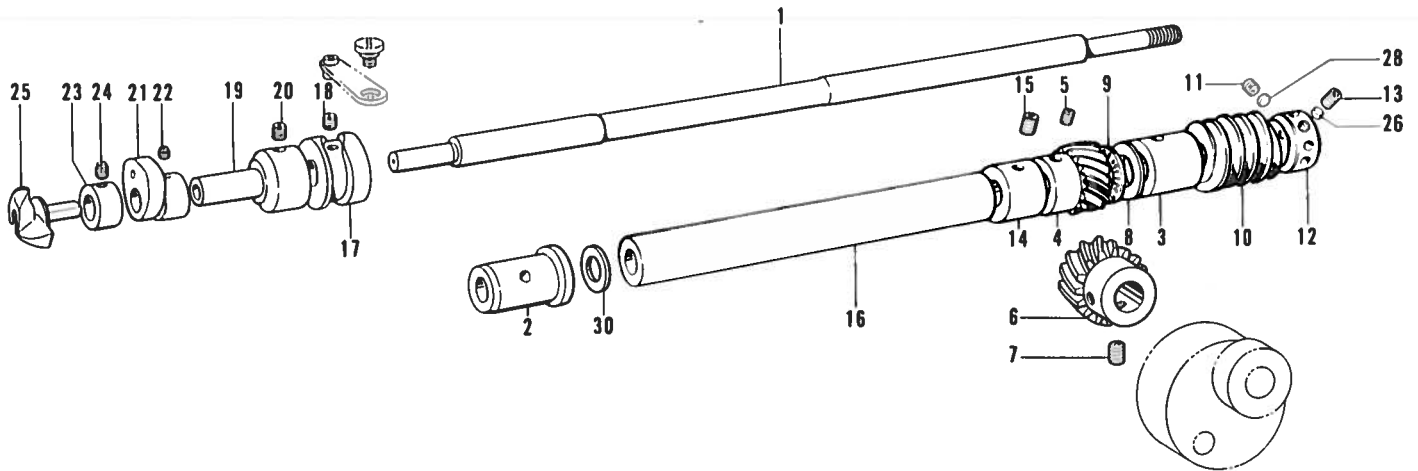

Ref. No.	Name of Parts	Q'ty	Parts No.	Assembly No.	Ref. No.	Name of Parts	Q'ty	Parts No.	Assembly No.
1	Lower Shaft	1	115057-001		15	Screw 6.35 x 6	2	014770-622	
2	Lower Shaft Bushing (Front)	1	115058-100		16	Distance Collar	1	115064-101	
3	Lower Shaft Bushing (Rear)	1	115059-000		17	Grooved Cam	1	115065-000	
4	Lower Shaft Gear	1	115060-001		18	Screw 5.56	2	110124-001	
5	Screw 6.35 x 6	2	014770-622		19	Shaft	1	115066-000	
6	Spiral Gear	1	115061-001		20	Screw 5.56 x 6	2	013750-610	
7	Screw 6.35 x 6	2	014770-622		21	Triangular Cam	1	115067-001	
8	Washer	1	115007-001		22	Screw 4.37	2	151601-002	
9	Thrust Bearing	1	115008-000		23	Collar	1	115068-001	
10	Worm	1			24	Screw 4.37	1	151602-001	
11	Screw 6.35 x 6	2	014770-622		25	Rotary Looper	1	115069-001	
12	Fastening Ring	1	114973-001		26	Washer	1	101028-000	
13	Screw 6.35 x 6	1	014770-622		28	Washer	2	101028-000	
14	Collar	1	115063-001		30	Horizontal Feed Crank Ring	1	142628-001	

F. Stitch number conversion / Stichzahlumrechnung
Conversion de nombre de points / Conversión de número de puntadas

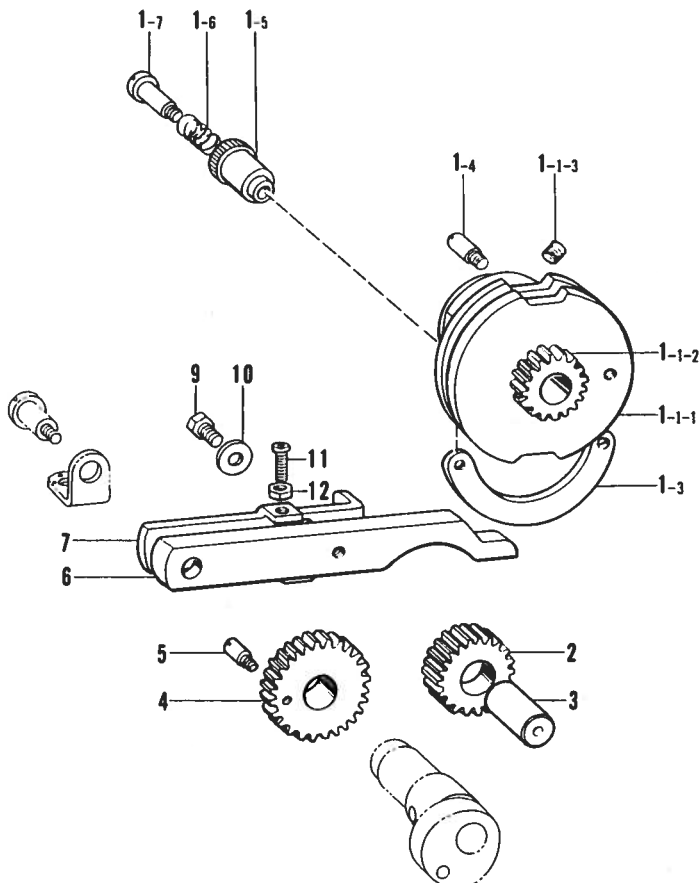

Ref. No.	Name of Parts	Q'ty	Parts No.	Assembly No.
1- 1- 1	Stitch Control Cam	1		F-1-1
1- 1- 2	Stitch Control Cam Gear	1		Stitch Control
1- 1- 3	Screw 7.94 x 10	2	014821-022	Cam Assembly 115109-101
1- 3	Stitch Control Cam Segment	1	115112-101	
1- 4	Screw 4.37	1	115113-001	F-1
1- 5	Stitch Control Knob	1	115114-001	Stitch Control
1- 6	Spring	1	115115-001	Assembly 180982-001
1- 7	Stud Screw 4.37	1	115116-001	
2	Stitch Changing (M) Gear	1	115117-000	
3	Stud	1	115118-001	
4	Stitch Changing Gear	1	115119-001	
5	Pin	1	115120-001	
6	Lever for 32-Stitches (Major)	1	115121-101	
7	Lever for 32-Stitches (Minor)	1	147114-001	
9	Bolt 4.76	1	117363-001	
10	Washer 4.76	1	025710-232	
11	Screw 318-40 x 12	1	062661-212	
12	Nut 3.18	1	021660-102	

G. Feed mechanism / Transportvorrichtung
 Mécanisme de l'entraînement / Mecanismo de la alimentación

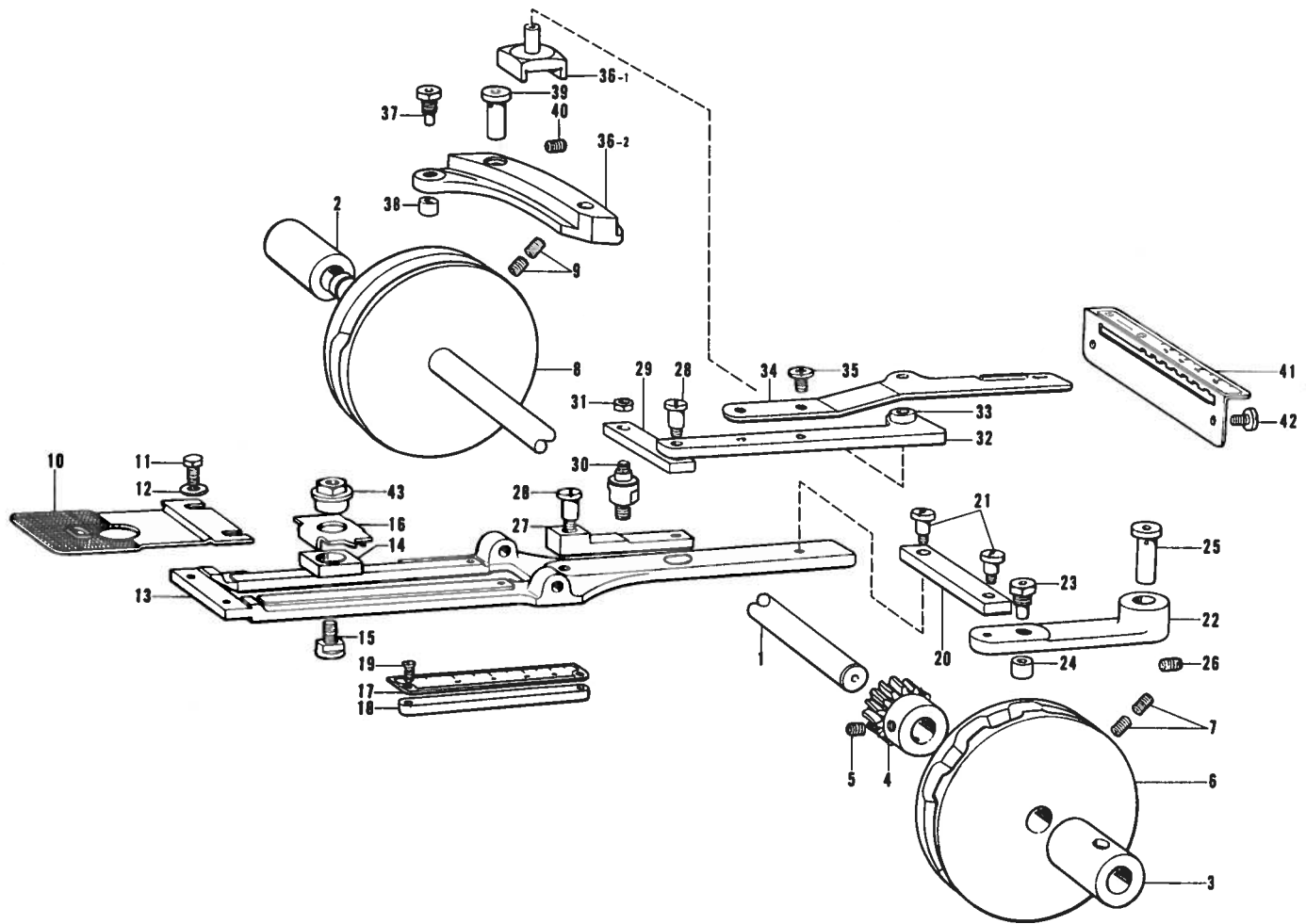

Ref. No.	Name of Parts	Q'ty	Parts No.	Assembly No.	Ref. No	Name of Parts	Q'ty	Parts No.	Assembly No.
1	Cam Shaft	1	115078-101		24	Roller	1	115098-001	
2	Cam Shaft Bushing (Left)	1	115079-000		25	Feed Lever Shaft	1	115099-001	
3	Cam Shaft Bushing (Right)	1	115080-000		26	Screw 5.95	1	151605-002	
4	Worm Gear	1			27	Back & Forth Feed Link	1	115100-001	
5	Screw 6.35 x 6	2	014770-622		28	Stud Screw 4.76	2	115101-001	
6	Transverse-Feed Cam	1			29	Feed Link	1	115094-001	
7	Screw 6.35 x 6	4	014770-622		30	Stud	1	115102-001	
8	Back & Forth Feed Cam	1	115084-000		31	Nut 4.76	1	021710-102	
9	Screw 6.35 x 6	4	014770-622		32	Back & Forth Feed Connector	1	115103-001	
10	Feed Plate (A)	1	144659-101		33	Bushing	1	115104-001	
11	Bolt 4.76 x 7	2	146360-002		34	Back & Forth Feed Adjusting Lever	1	115105-001	
12	Washer	2	146354-001		35	Screw 437-40 x 7	2	062680-712	
13	Feed Bracket (for B913)	1	115087-000		36- 1	Back & Forth Feed Slide Block	1	115106-001	G-36 Back & Forth Feed Adjusting Assembly 180910-001
	Feed Bracket (for B915)	1	151882-001						
14	Transverse-Feed Slide Block	1	115088-001	36- 2	Back & Forth Feed Lever	1			
15	Screw	1	115089-001	37	Stud	1	115097-001		
16	Transverse-Feed Plate	1	115090-001	38	Roller	1	115098-001		
17	Transverse-Feed Length Indicator	1	115092-001	39	Feed Lever Shaft	1	115099-001		
18	Supporting Plate	1	115093-001	40	Screw 5.95	1	117685-001		
19	Screw 3.18	2	117291-002	41	Back & Forth Feed Length Indicator	1	115108-001		
20	Feed Link	1	115094-001	42	Screw 476-32 x 7	2	062710-712		
21	Stud Screw 4.76	2	115095-001	43	Transverse-Feed Adjusting Nut	1	115091-001		
22	Transverse-Feed Lever	1	115096-000						
23	Stud	1	115097-001						

H. Threading mechanism / fadenführungsrichtung
 Mécanisme de fénilage / Mecanismo de la enhebrado

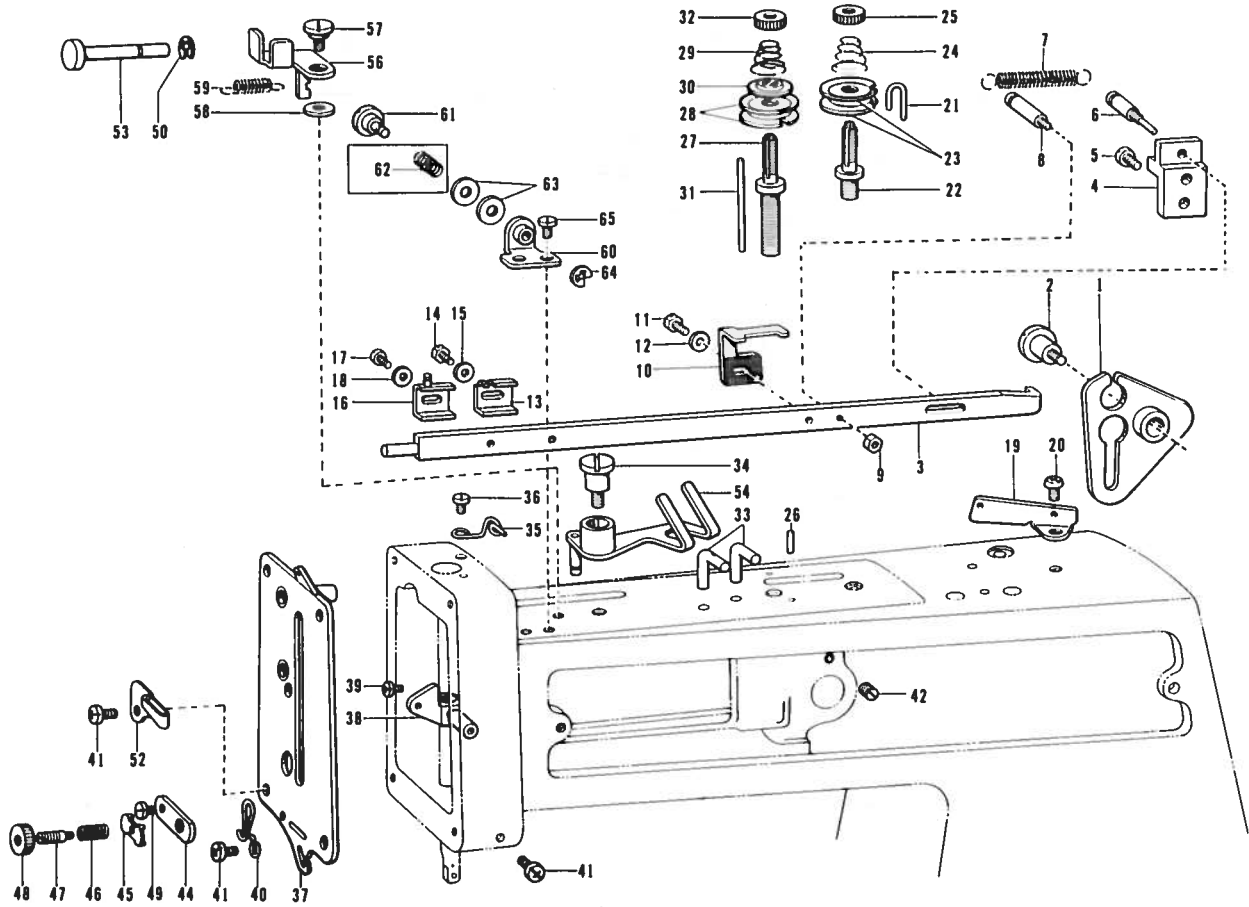

Ref. No.	Name of Parts	Q'ty	Parts No.	Assembly No.	Ref. No.	Name of Parts	Q'ty	Parts No.	Assembly No.
1	Thread Release Cam	1	115171-001		32	Tension Control Nut	1	100136-001	
2	Stud Screw 6.35	1	115172-001		33	Pin	2	115192-001	
3	Thread Release Connecting Bar	1	115173-001		34	Stud Screw 5.56	1	110249-001	
4	Guide Bracket	1	115174-001		35	Arm Thread Guide	1	115204-001	
5	Screw 476-32 x 12	2	062711-212		36	Screw 476-32 x 10	1	062711-012	
6	Pin	1	115175-001		37	Face Plate Assembly	1	117879-001	
7	Spring (for B913)	1	115176-001		38	Needle Bar Thread Guide	1	153808-001	
	Spring (B) (for B915)	1	151994-001		39	Screw 357-40 x 10	1	062671-012	
8	Spring Hanger	1	115177-001		40	Face Plate Thread Guide	1	115212-101	
9	Nut 3.18	1	021660-102		41	Screw 476-32 x 10	5	062711-012	
10	Thread Release Lever	1	115178-001		42	Screw 4.76	1	013710-512	
11	Bolt 4.76	1	117363-001		44	Sub Tension Plate	1	142360-001	
12	Washer	1	146354-001		45	Needle Thread Guard	1	112300-001	
13	Adjuster	1	115179-001		46	Sub Tension Spring	1	151880-000	
14	Bolt 4.76	1	117363-001		47	Sub Tension Stud	1	151879-001	
15	Washer	1	146354-001		48	Tension Control Nut	1	107682-001	
16	Presser Lever Bracket	1	115180-001		49	Screw 3.57	1	116323-001	
17	Screw 476-32 x 7	1	062710-712		50	Stop Ring E3	1	048030-342	
18	Washer	1	146354-001		52	Thread Guide	1	151881-001	
19	Thread Retainer	1	115183-101		53	Thread Releaser	1	142672-001	
20	Screw 476-32 x 7	1	062710-712		54	Thread Take-Up Lever Assembly	1	144486-001	
21	Main Tension Thread Guide	1	115184-001		56	Thread Presser lever	1	144669-001	
22	Main Tension Stud	1	115186-001		57	Stud Screw 5.56	1	144670-001	
23	Tension Disc	2	115187-101		58	Washer 6	1	025060-132	
24	Spring	1	115188-001		59	Spring (for B913)	1	144671-001	
25	Tension Control Nut	1	100136-001			Spring (for B915)	1	151970-001	
26	Pin	1	115189-001		60	Indicator Plate	1	144672-001	
27	Tension Stud	1	115190-001		61	Thread Presser Shaft	1	144673-001	
28	Tension Disc	2	115187-101		62	Spring (for B913)	1	144674-000	
29	Tension Spring	1	104525-001		63	Pre-Tension Disc	2	100546-001	
30	Tension Disc Washer	1	159805-001		64	Stop Ring E3	1	048030-346	
31	Pin	1	115191-001		65	Screw 476-32 x 10	2	062711-012	

[B913]

J. Button clamp mechanism / Knopfhaltevorrichtung
 Mécanisme du pince-boutons / Mecanismo de la ménsula del botón

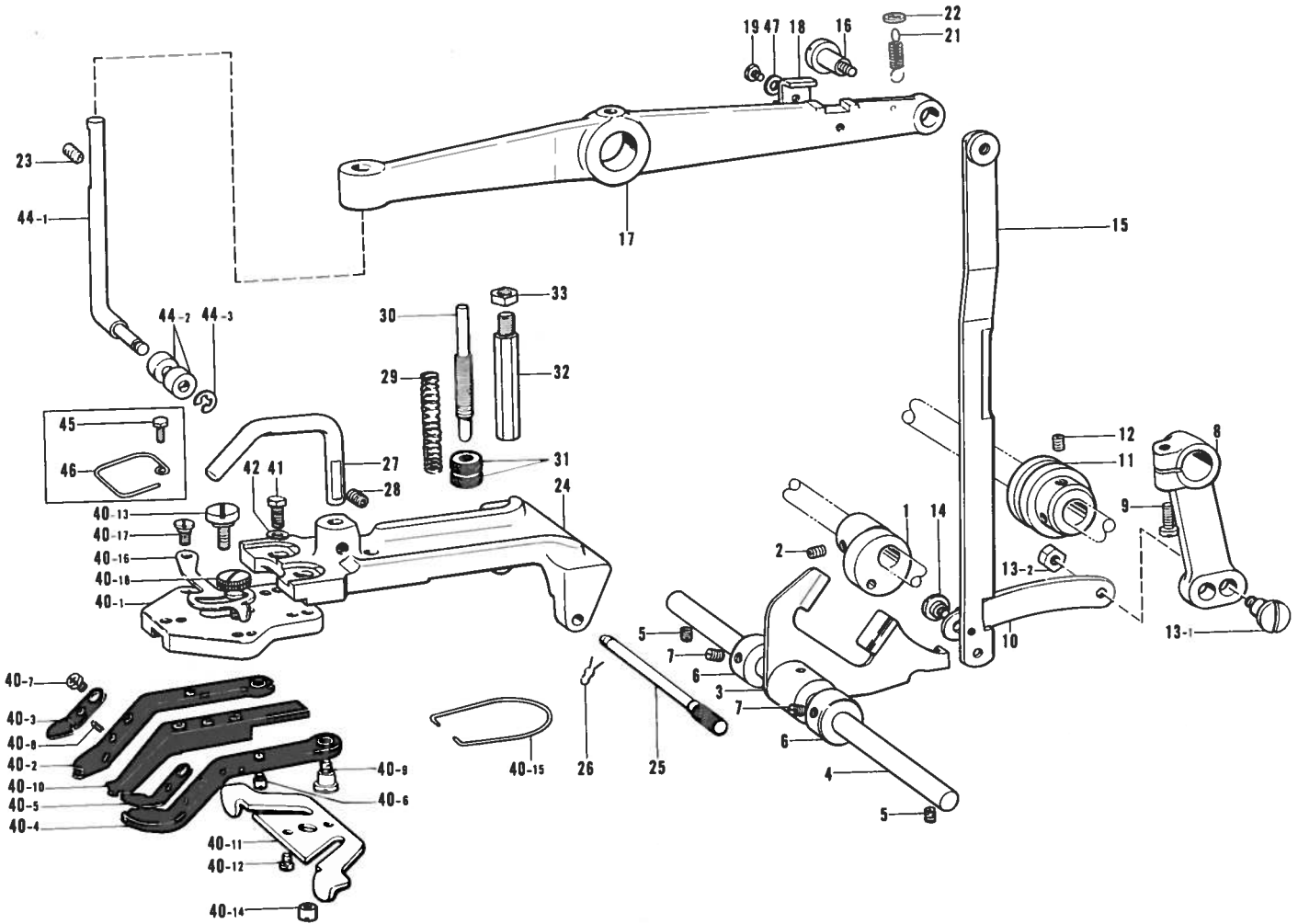

Ref. No.	Name of Parts	Q'ty	Parts No.	Assembly No.	Ref. No.	Name of Parts	Q'ty	Parts No.	Assembly No.
1	Cam	1	115124-001		31	Tension Control Nut	2	146994-001	
2	Screw 6.35 x 6	2	014770-622		32	Stopper	1	115149-001	
3	Button Clamp Driving Fork	1	115125-101		33	Nut 5.56	1	107282-002	
4	Button Clamp Driving Shaft	1	115126-001		40- 1	Button Clamp Bracket	1	115151-000	J-40 Button Clamp Assembly 150403-101
5	Screw 5.56 x 10	2	013751-010		40- 2	Button Clamp (Left)	1	150397-101	
6	Collar	2	115127-001		40- 3	Spring	1	150398-001	
7	Screw 4.76	4	013710-512		40- 4	Button Clamp (Right)	1	150399-101	
8	Button Clamp Driving Lever	1	115128-100		40- 5	Spring	1	150401-001	
9	Screw 5.56-32 x 16	1	062751-612		40- 6	Pin	2	115156-001	
10	Button Clamp Driving Link	1	115130-001		40- 7	Screw 4.37-40 x 5	2	062680-512	
11	Button Clamp Driving Link Guide	1	115131-101		40- 8	Spring Pin	2	047250-642	
12	Screw 6.35 x 6	2	014770-622		40- 9	Stud Screw 4.76	2	115158-001	
13- 1	Stud Screw 4.76	1	156874-001		40-10	Button Clamp (Middle)	1	150402-001	
13- 2	Nut 4.76	1	110161-004		40-11	Button Clamp Plate	1	115269-001	
14	Stud Screw 4.76	1	115133-001		40-12	Screw 3.57-40 x 8	2	062670-812	
15	Button Clamp Driving Connector	1	115134-101		40-13	Stud Screw 3.57	1	115161-001	
16	Stud Screw 4.76	1	115101-001		40-14	Nut 3.57	1	115162-001	
17	Button Clamp Lifter Lever	1	115135-101		40-15	Spring	1	115163-001	
18	Stopper	1	117873-101		40-16	Button Clamp Adjusting Plate	1	115164-001	
19	Screw 4.37	1	107407-003		40-17	Stud Screw 4.37	1	115165-001	
21	Spring	1	115137-001		40-18	Stud Screw 4.37	1	115166-001	
22	Spring Hook	1	115138-001		41	Bolt 4.76 x 14	2	017711-412	
23	Screw 6.35	1	014770-622		42	Washer	2	146354-001	
24	Button Clamp Holder	1	115143-202		44- 1	Button Clamp Lifter	1	115139-001	J-44 Clamp Lifter Assembly 142308-001
25	Button Clamp Holder Bar	1	115144-001		44- 2	Roller	2	107744-001	
26	Snap	1	115145-001		44- 3	Stop Ring E3	1	048030-342	
27	Hook	1	115146-001		47	Washer	1	146354-001	
28	Screw 6.35	1	014770-622		Option				
29	Spring	1	115147-001		45	Finger Guard	1	151051-001	
30	Screw	1	115148-101		46	Bolt 4.76 x 7	1	146360-002	

[B915]

K. Button clamp mechanism / Knopfhaltvorrichtung
 Mécanisme du pince-boutons / Mecanismo de la ménsula del botón

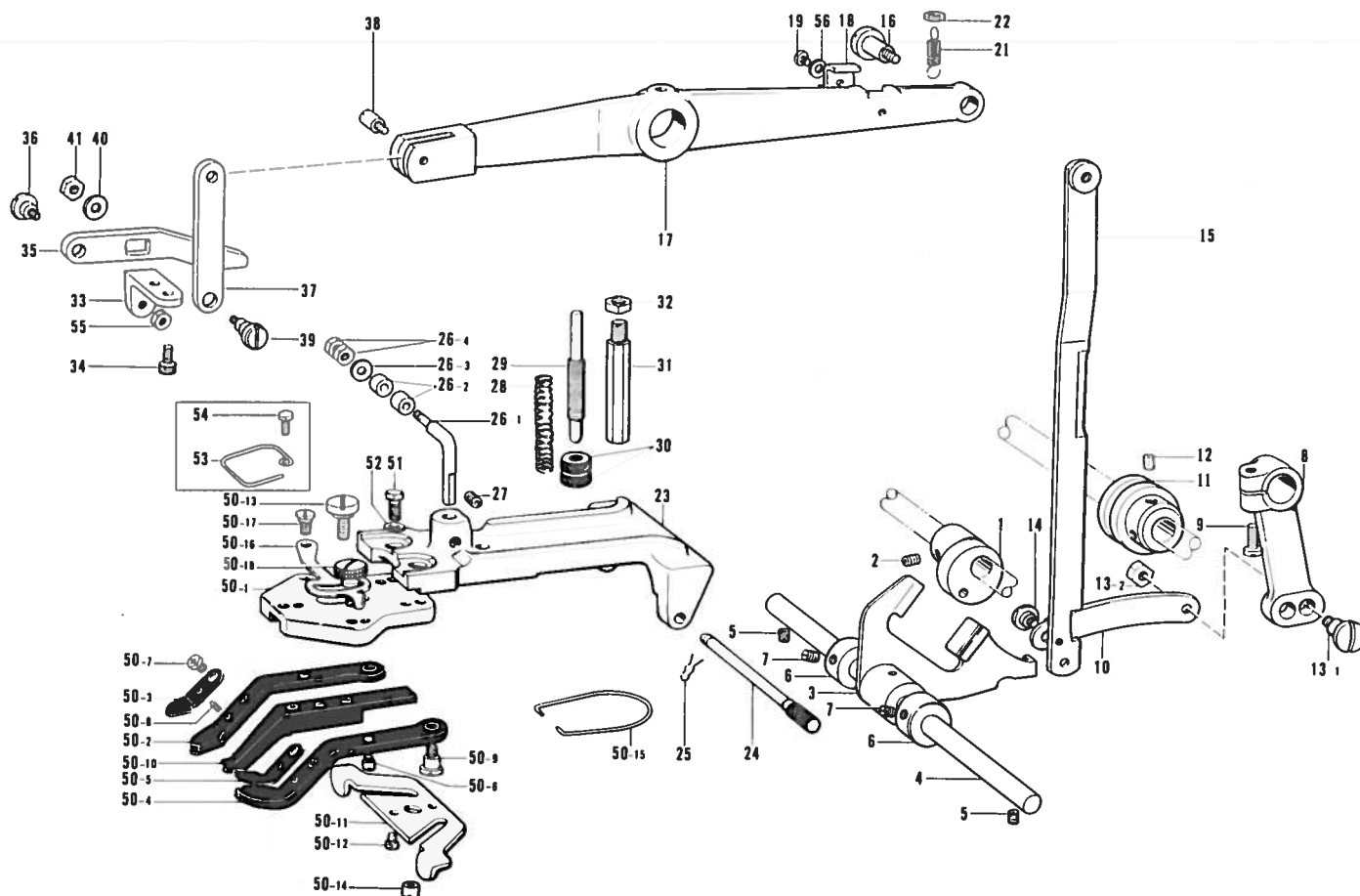

Ref. No.	Name of Parts	Q'ty	Parts No.	Assembly No.	Ref. No.	Name of Parts	Q'ty	Parts No.	Assembly No.
1	Cam	1	151961-001		33	Button Clamp Lifter Bracket	1	151964-001	
2	Screw 6.35 x 6	2	014770-622		34	Bolt 6 x 14	2	018061-422	
3	Button Clamp Driving Fork	1	115125-101		35	Button Clamp Lifter	1	151965-001	
4	Button Clamp Driving Shaft	1	115126-001		36	Stud Screw 6.35	1	115389-002	
5	Screw 5.56 x 10	2	013751-010		37	Button Clamp Lifter Link	1	151966-001	
6	Collar	2	115127-001		38	Screw	1	115449-001	
7	Screw 4.76	4	013710-512		39	Stud Screw 6.35	1	151967-001	
8	Button Clamp Driving Lever	1	115128-100		40	Washer	1	118735-002	
9	Screw 556-32 x 16	1	062751-612		41	Nut 6.35	1	110744-002	
10	Button Clamp Driving Link	1	115130-001		50- 1	Button Clamp Bracket	1	115151-000	K-50 Button Clamp Assembly 150403-101
11	Button Clamp Driving Link Guide	1	115131-101		50- 2	Button Clamp (Left)	1	150397-101	
12	Screw 6.35 x 6	2	014770-622		50- 3	Spring	1	150398-001	
13- 1	Stud Screw 4.76	1	156874-001		50- 4	Button Clamp (Right)	1	150399-101	
13- 2	Nut 4.76	1	110161-004		50- 5	Spring	1	150401-001	
14	Stud Screw 4.76	1	115133-001		50- 6	Pin	2	115156-001	
15	Button Clamp Driving Connector	1	115134-101		50- 7	Screw 437-40 x 5	2	062680-512	
16	Stud Screw 4.76	1	151962-001		50- 8	Spring Pin	2	047250-642	
17	Button Clamp Lifter Lever	1	151963-101		50- 9	Stud Screw 4.76	2	115158-001	
18	Stopper	1	117873-101		50-10	Button Clamp (Middle)	1	150402-001	
19	Screw 4.37	1	107407-003		50-11	Button Clamp Plate	1	115269-001	
21	Spring	1	115137-001		50-12	Screw 357-40 x 8	2	062670-812	
22	Spring Hook	1	115138-001		50-13	Stud Screw 3.57	1	115161-001	
23	Button Clamp Holder	1	115143-202		50-14	Nut 3.57	1	115162-001	
24	Button Clamp Holder Bar	1	115144-001		50-15	Spring	1	115163-001	
25	Snap	1	115145-001		50-16	Button Clamp Adjusting Plate	1	115164-001	
26- 1	Button Clamp Holder Hook	1	151969-001	K-26 Button Clamp Holder Hook Assembly 151968-001	50-17	Stud Screw 4.37	1	115165-001	
26- 2	Roller	2	107744-001		50-18	Stud Screw 4.37	1	115166-001	
26- 3	Washer 4.76	1	153484-001		51	Bolt 4.76 x 14	2	017711-412	
26- 4	Nut 4.37	2	105234-003		52	Washer	2	146354-001	
27	Screw 6.35 x 6	1	014770-622		55	Nut 6.35	1	150556-001	
28	Spring	1	115147-001		56	Washer	1	146354-001	
29	Screw	1	115148-101		Option				
30	Tension Control Nut	2	146994-001		53	Finger Guard	1	151051-001	
31	Stopper	1	115149-001		54	Bolt 4.76 x 7	1	146360-002	
32	Nut 5.56	1	107282-002						

[B915]

L. Thread trimmer mechanism / Fadenabschneidevorrichtung
 Mécanisme de coupe-fill / Mécanismo de recortadora de orillos

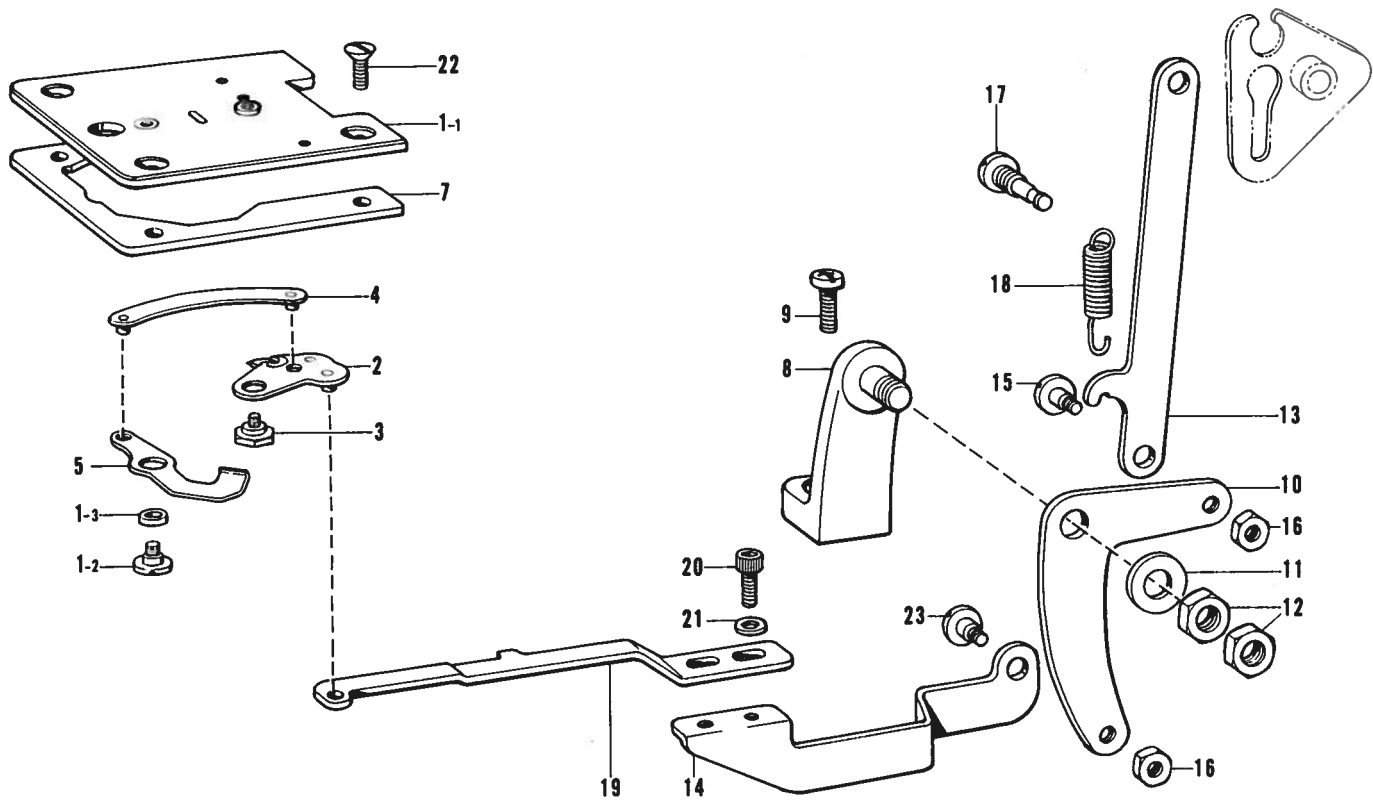

Ref. No.	Name of Parts	Q'ty	Parts No.	Assembly No.	Ref. No.	Name of Parts	Q'ty	Parts No.	Assembly No.
1- 1	Needle Plate	1	153760-001		12	Nut 4.37	2	105234-003	
1- 2	Screw 3.57	1	153761-001		13	Connecting Link	1	151985-001	
1- 3	Collar	1	153759-001		14	Knife Driving Lever (Large)	1	151986-101	
2	Movable Knife (A) Assembly	1	151972-001		15	Stud Screw 4.37	1	151987-001	
3	Stud Screw	1	151977-001		16	Nut 4.37	2	021680-202	
4	Connecting Plate	1	151978-001		17	Spring Hook	1	151988-001	
5	Movable Knife (B)	1	151979-001		18	Spring	1	151989-001	
7	Needle Plate Subordinate	1	151981-001		19	Knife Driving Lever (Small)	1	151990-101	
8	Thread Trimming Lever Bracket	1	152192-101		20	Bolt 4.37 x 10	2	018681-022	
9	Screw 476-32 x 12	2	062711-212		21	Washer	2	100645-003	
10	Thread Trimming Lever	1	151983-001		22	Screw 4.37 x 10	3	S01702-001	
11	Slide Plate	1	146549-001		23	Stud Screw 4.37	1	144526-001	



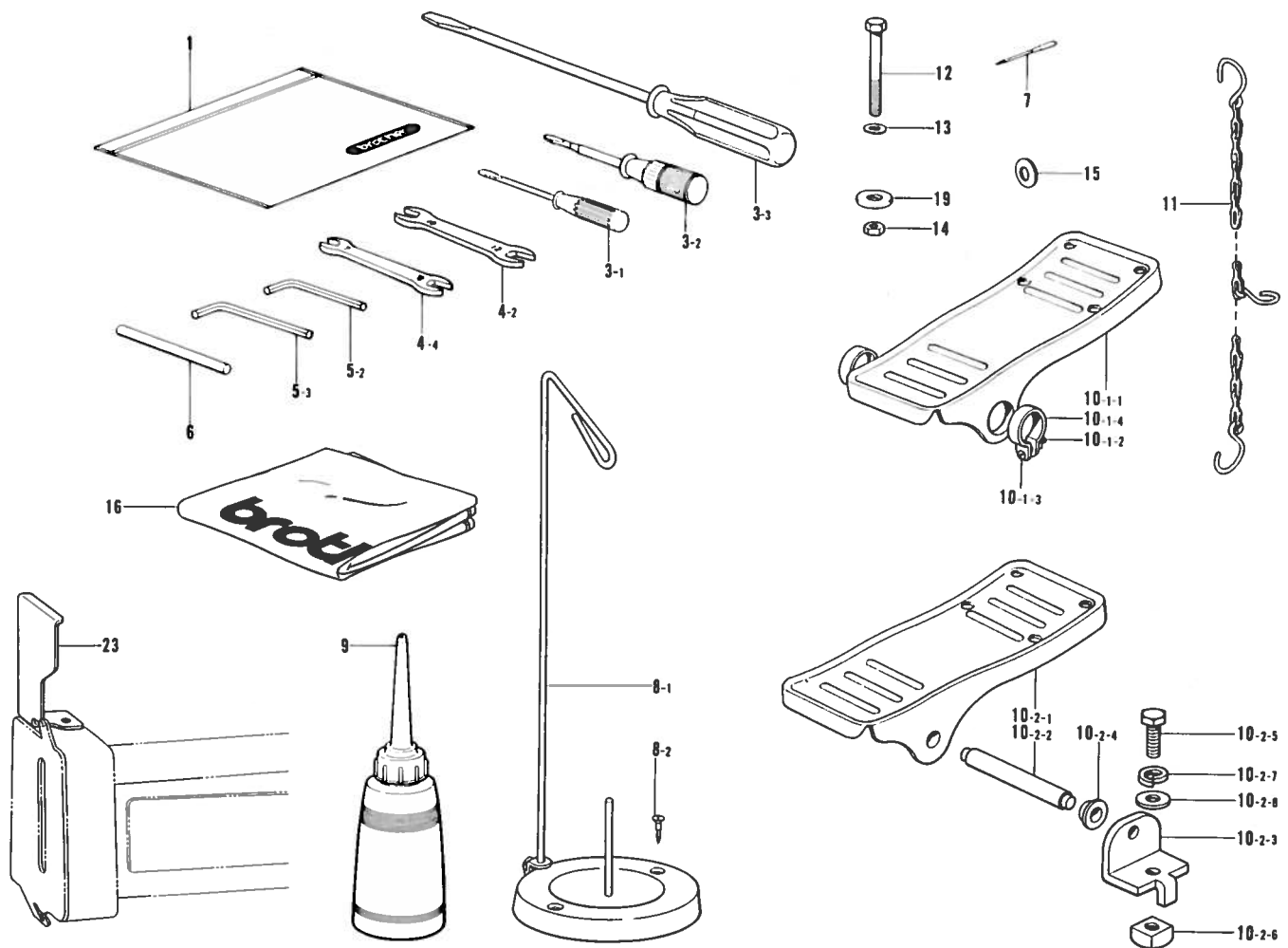

Z. Accessories / Zubehör
Accessoires / Accesorios





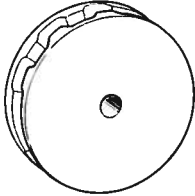
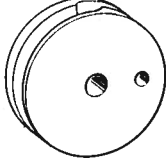

Ref. No.	Name of Parts	Q'ty	Parts No.	Assembly No.	Ref. No.	Name of Parts	Q'ty	Parts No.	Assembly No.
1	Vinyl Bag	1	122991-001		10- 1- 4	Pedal Stopper	2	116016-001	Z-10-1
3- 1	Screw Driver 2.6 x 70	1	105344-001		10- 2- 1	Pedal	1	S01199-001	
3- 2	Screw Driver 3.4 x 70	1	118837-001		10- 2- 2	Pedal Shaft	1	133188-001	
3- 3	Screw Driver 5.5 x 190	1	101572-101		10- 2- 3	Pedal Shaft Bracket	2	119707-001	Z-10-2
4- 2	Spanner 10 x 12	1	107780-001		10- 2- 4	Pedal Shaft Collar	2	119708-001	Padal
4- 4	Spanner 7 x 8	1	142205-001		10- 2- 5	Bolt 8 x 22	2	017082-206	Assembly
5- 2	Spanner 3	1	142721-001		10- 2- 6	Nut 8	2	116694-001	(for Z Type
5- 3	Spanner 4	1	118064-001		10- 2- 7	Spring Washer 2-8	2	028080-240	Stand)
6	Worm Adjusting Bar	1	115123-001		10- 2- 8	Washer 8	2	025080-236	S01603-001
7	Needle TQ x 1 #14	2	115053-014		11	Chain Assembly	1	142656-001	
	Needle TQ x 1 #16	2	115053-016		12	Bolt 6 x 63	4	144543-001	
	Needle TQ x 1 #18	2	115053-018		13	Washer 6	4	025060-232	
8- 1	Spool Stand	1	109854-001		14	Nut 6	4	021060-102	
8- 2	Screw 4.5 x 32	2	100447-001		15	Washer	2	115017-001	
9	Oiler	1	114483-002		16	Head Cover	1	144224-001	
10- 1- 1	Pedal	1	117437-101	Z-10-1	19	Washer	4	115947-001	
10- 1- 2	Nut 4	2	021400-106	Pedal	23	Needle Bar Guard	1	156540-001	
10- 1- 3	Screw 4 x 14	2	001401-416	Assembly					
				116185-201					

Different parts list / Zubehörliste

Liste des pièces accessoires / Lista de piezas accesorias

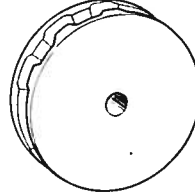
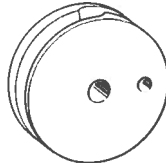
Ref. No.		G-4	G-6	G-8	E-10	
Name of Parts						
Sub-class	Stitch Form	Number of Stitch	Worm Gear	Transverse-Feed Cam	Back & Forth Feed Cam	Worm
-1		8, 16, 32	115081-001	115082-000	115084-000	115062-001
-2		6, 12, 24	118544-001	118542-000		118543-001
-3		8, 16, 32	115081-001	153566-000		115062-001

Option / Option / Option / Opción

Ref. No.		G-4	G-6	G-8	E-10
Name of Parts					
Stitch Form	Number of Stitch	Worm Gear	Transverse-Feed Cam	Back & Forth Feed Cam	Worm
	6, 12, 24	118544-001	118542-000	S01663-000	118543-001
				S00863-000 (for B915)	

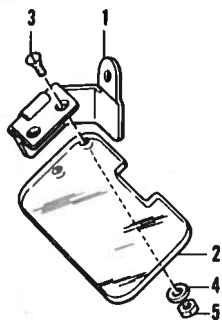

Ref. No.	Name of Parts	Q'ty	Parts No.	Assembly No.
1	Eye Guard Hinge Assembly	1	143964-001	Eye Guard Assembly 153196-001
2	Eye Guard	1	153197-001	
3	Screw 3.18 x 7	2	S01700-001	
4	Washer 3.18	2	025030-232	
5	Nut 3.18	2	021660-102	

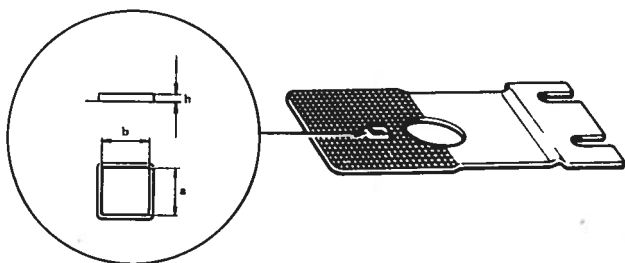

Ref. No.	Name of Parts	Parts No.	a x b x h
G-10	Feed Plate (A)	144659-101	4.8 x 4.8 x 0.8
	Feed Plate (B)	115085-001	7 x 7 x 0
	Feed Plate (C)	151960-001	7 x 7 x 0.8

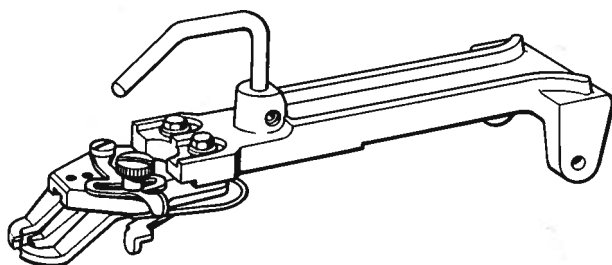

Snap Holder Assembly
115167-001

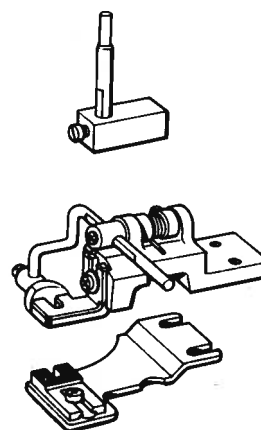

Shank Button Attachment
142570-101

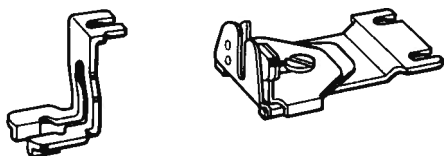

Wrapping button Attachment
150416-001

INDEX / VERZEICHNIS INDEX / INDICE

Parts No.	Ref No.	Remark	Parts No.	Ref No.	Remark	Parts No.	Ref No.	Remark	Parts No.	Ref No.	Remark
S00863-000	G- 8		047250-642	K- 50- 8		114982-000	A- 15		115072-001	D- 4	
S01199-001	Z- 10- 2- 1		048030-342	H- 50		114984-000	A- 18		115073-001	D- 5	
S01603-001	Z- 10- 2			J- 44- 3		114985-001	A- 20		115076-001	D- 6	
S01663-000	G- 8		048030-346	H- 64		114986-001	A- 23		115077-001	D- 7	
S01696-001	D- 2		062661-212	F- 11		114988-001	A- 26		115078-101	G- 1	
S01702-001	C- 15		062670-812	J- 40-12		114989-001	B- 1		115079-000	G- 2	
	L- 22			K- 50-12		114990-001	B- 4		115080-000	G- 3	
001401-416	Z- 10- 1- 3		062671-012	H- 39		114991-001	B- 4- 1		115081-001	G- 4	
013710-512	H- 42		062680-512	J- 40- 7		114992-000	B- 4- 2		115082-000	G- 6	
	J- 7			K- 50- 7		114993-000	B- 4- 3		115084-000	G- 8	
	K- 7		062680-712	A- 21		114994-001	B- 4- 4		115085-001	G- 10	
013710-712	B- 4- 7			G- 35		114995-001	B- 4- 5		115087-000	G- 13	
013711-010	A- 30		062710-712	C- 12		114997-001	B- 4- 8		115088-001	G- 14	
	A- 32			G- 42		114998-000	B- 5		115089-001	G- 15	
013750-610	A- 19			H- 17		114999-001	B- 6		115090-001	G- 16	
	B- 38			H- 20		115000-000	B- 7		115091-001	G- 43	
	E- 20		062711-012	H- 36		115002-101	B- 10		115092-001	G- 17	
013751-010	A- 31			H- 41		115003-001	B- 11		115093-001	G- 18	
	J- 5			H- 65		115004-001	B- 12		115094-001	G- 20	
	K- 5		062711-212	B- 29		115007-001	B- 15			G- 29	
013770-610	A- 29			H- 5			E- 8		115095-001	G- 21	
014770-622	C- 1- 4			L- 9		115008-000	B- 16		115096-000	G- 22	
	E- 5		062751-612	J- 9			E- 9		115097-001	G- 23	
	E- 7			K- 9		115010-001	B- 17- 2			G- 37	
	E- 11		071079-450	B- 4- 6		115011-001	B- 17- 3		115098-001	G- 24	
	E- 13		100136-001	H- 25		115012-002	B- 17- 4			G- 38	
	E- 15			H- 32		115013-001	B- 18		115099-001	G- 25	
	G- 5		100447-001	Z- 8- 2		115014-001	B- 17- 6			G- 39	
	G- 7		100546-001	H- 63		115015-101	B- 17- 7		115100-001	G- 27	
	G- 9		100645-003	L- 21		115016-001	B- 17- 8		115101-001	G- 28	
	J- 2		101028-000	E- 26		115017-001	B- 17- 9			J- 16	
	J- 12			E- 28			Z- 15		115102-001	G- 30	
	J- 23		101572-101	Z- 3- 3		115018-001	B- 17-10		115103-001	G- 32	
	J- 28		102571-003	B- 36		115020-001	B- 19		115104-001	G- 33	
	K- 2		104525-001	H- 29		115021-001	B- 20		115105-001	G- 34	
	K- 12		105234-003	K- 26- 4		115022-001	B- 21		115106-001	G- 36- 1	
	K- 27			L- 12		115025-001	B- 27		115108-001	G- 41	
014821-022	B- 14		105329-001	A- 25		115026-001	B- 28		115109-101	F- 1- 1	
	F- 1- 1- 3		105344-001	Z- 3- 1		115027-101	B- 30		115112-101	F- 1- 3	
015770-812	C- 1- 5		105872-101	B- 52		115041-001	C- 1-11		115113-001	F- 1- 4	
017082-206	Z- 10- 2- 5		106629-002	A- 12		115042-001	C- 1-13		115114-001	F- 1- 5	
017711-412	J- 41		107155-001	C- 1-15		115046-001	C- 2		115115-001	F- 1- 6	
	K- 51		107282-002	J- 33		115047-001	C- 3		115116-001	F- 1- 7	
017751-412	C- 17			K- 32		115048-001	C- 16- 1		115117-000	F- 2	
017822-212	B- 31		107407-003	J- 19		115050-001	C- 6		115118-001	F- 3	
018061-422	K- 34			K- 19		115051-000	C- 7		115119-001	F- 4	
018681-022	L- 20		107682-001	H- 48		115052-000	C- 8		115120-001	F- 5	
021060-102	Z- 14		107744-001	J- 44- 2		115053-014	Z- 7		115121-101	F- 6	
021400-106	Z- 10- 1- 2			K- 26- 2		115053-016	C- 9		115123-001	Z- 6	
021660-102	F- 12		107780-001	Z- 4- 2			Z- 7		115124-001	J- 1	
	H- 9		107793-000	B- 47		115053-018	Z- 7		115125-101	J- 3	
021670-202	A- 8		109854-001	Z- 8- 1		115054-101	C- 11			K- 3	
021680-202	L- 16		110104-000	A- 33		115055-001	C- 13		115126-001	J- 4	
021710-102	G- 31		110124-001	E- 18		115057-001	E- 1			K- 4	
021750-102	B- 8		110161-004	B- 54		115058-100	E- 2		115127-001	J- 6	
	B- 26			J- 13- 2		115059-000	E- 3			K- 6	
	C- 19			K- 13- 2		115060-001	E- 4		115128-100	J- 8	
021800-102	B- 17-12		110249-001	H- 34		115061-001	E- 6			K- 8	
	C- 1-12		110744-002	K- 41		115062-001	E- 10		115130-001	J- 10	
025060-132	H- 58		112300-001	H- 45		115063-001	E- 14			K- 10	
025060-232	Z- 13		114483-002	Z- 9		115064-101	E- 16		115131-101	J- 11	
025080-236	Z- 10- 2- 8		114973-001	E- 12		115065-000	E- 17			K- 11	
025710-232	B- 24		114976-003	A- 6		115066-000	E- 19		115133-001	J- 14	
	F- 10		114977-001	A- 9		115067-001	E- 21			K- 14	
025800-332	B- 17-11		114978-103	A- 10		115068-001	E- 23		115134-101	J- 15	
028080-240	Z- 10- 2- 7		114979-103	A- 11		115069-001	E- 25			K- 15	
047250-642	J- 40- 8		114980-001	A- 13		115071-001	D- 3		115135-101	J- 17	

Parts No.	Ref No.	Remark	Parts No.	Ref No.	Remark	Parts No.	Ref No.	Remark	Parts No.	Ref No.	Remark
115137-001	J- 21		115389-002	K- 36		146354-001	G- 12		151993-001	D- 4	
	K- 21		115449-001	K- 38			H- 12		151994-001	H- 7	
115138-001	J- 22		115947-001	Z- 19			H- 15		152192-101	L- 8	
	K- 22		116016-001	Z- 10- 1- 4			H- 18		153484-001	K- 26- 3	
115139-001	J- 44- 1		116185-201	Z- 10- 1			J- 42		153542-001	B- 9	
115143-202	J- 24		116323-001	H- 49			J- 47		153566-000	G- 6	
	K- 23		116694-001	Z- 10- 2- 6			K- 52		153759-001	L- 1- 3	
115144-001	J- 25		117291-002	G- 19			K- 56		153760-001	L- 1- 1	
	K- 24		117363-001	F- 9		146360-002	G- 11		153761-001	L- 1- 2	
115145-001	J- 26			H- 11			J- 46		153808-001	H- 38	
	K- 25			H- 14			K- 54		154224-003	A- 17	
115146-001	J- 27		117437-101	Z- 10- 1- 1		146549-001	L- 11		154225-003	A- 16	
115147-001	J- 29		117685-001	G- 40		146994-001	J- 31		156540-001	Z- 23	
	K- 28		117873-101	J- 18			K- 30		156874-001	J- 13- 1	
115148-101	J- 30			K- 18		147114-001	F- 7			K- 13- 1	
	K- 29		117879-001	H- 37		148425-002	C- 1- 7		159805-001	H- 30	
115149-001	J- 32		118064-001	Z- 5- 3		149995-001	B- 9		180910-001	G- 36	
	K- 31		118542-000	G- 6		149996-001	B- 13		180982-001	F- 1	
115151-000	J- 40- 1		118543-001	E- 10		150397-101	J- 40- 2		182350-001	C- 16	
	K- 50- 1		118544-001	G- 4			K- 50- 2				
115156-001	J- 40- 6		118735-002	K- 40		150398-001	J- 40- 3				
	K- 50- 6		118837-001	Z- 3- 2			K- 50- 3				
115158-001	J- 40- 9		119707-001	Z- 10- 2- 3		150399-101	J- 40- 4				
	K- 50- 9		119708-001	Z- 10- 2- 4			K- 50- 4				
115160-001	A- 28		122991-001	Z- 1		150401-001	J- 40- 5				
115161-001	J- 40-13		129986-001	A- 7			K- 50- 5				
	K- 50-13		133188-001	Z- 10- 2- 2		150402-001	J- 40-10				
115162-001	J- 40-14		140553-102	C- 10			K- 50-10				
	K- 50-14		142205-001	Z- 4- 4		150403-101	J- 40				
115163-001	J- 40-15		142307-001	B- 23			K- 50				
	K- 50-15		142308-001	J- 44		150554-002	B- 17- 5				
115164-001	J- 40-16		142360-001	H- 44		150556-001	K- 55				
	K- 50-16		142628-001	E- 30		151051-001	J- 45				
115165-001	J- 40-17		142656-001	Z- 11			K- 53				
	K- 50-17		142658-001	C- 1- 2		151601-002	E- 22				
115166-001	J- 40-18		142672-001	H- 53		151602-001	E- 24				
	K- 50-18		142721-001	Z- 5- 2		151604-001	B- 48				
115171-001	H- 1		144224-001	Z- 16		151605-002	G- 26				
115172-001	H- 2		144486-001	H- 54		151879-001	H- 47				
115173-001	H- 3		144509-000	B- 37		151880-000	H- 46				
115174-001	H- 4		144510-001	B- 39		151881-001	H- 52				
115175-001	H- 6		144513-001	B- 40		151882-001	G- 13				
115176-001	H- 7		144514-001	B- 41		151960-001	G- 10				
115177-001	H- 8		144515-001	B- 42		151961-001	K- 1				
115178-001	H- 10		144516-001	B- 43		151962-001	K- 16				
115179-001	H- 13		144517-001	B- 44		151963-101	K- 17				
115180-001	H- 16		144518-001	B- 45		151964-001	K- 33				
115183-101	H- 19		144519-001	B- 46		151965-001	K- 35				
115184-001	H- 21		144520-001	B- 49		151966-001	K- 37				
115186-001	H- 22		144523-001	B- 50		151967-001	K- 39				
115187-101	H- 23		144524-000	B- 51		151968-001	K- 26				
	H- 28		144525-001	B- 53		151969-001	K- 26- 1				
115188-001	H- 24		144526-001	B- 55		151970-001	H- 59				
115189-001	H- 26			L- 23		151972-001	L- 2				
115190-001	H- 27		144543-001	Z- 12		151977-001	L- 3				
115191-001	H- 31		144657-000	C- 18		151978-001	L- 4				
115192-001	H- 33		144659-101	G- 10		151979-001	L- 5				
115204-001	H- 35		144669-001	H- 56		151981-001	L- 7				
115212-101	H- 40		144670-001	H- 57		151983-001	L- 10				
115214-100	B- 3		144671-001	H- 59		151985-001	L- 13				
115215-000	B- 2		144672-001	H- 60		151986-101	L- 14				
115268-002	B- 22		144673-001	H- 61		151987-001	L- 15				
	B- 25		144674-000	H- 62		151988-001	L- 17				
115269-001	J- 40-11		144700-101	C- 1		151989-001	L- 18				
	K- 50-11		144701-000	C- 1-14		151990-101	L- 19				
115270-003	A- 27		144711-001	C- 14		151991-000	D- 1				
115275-001	A- 24		144747-201	B- 17		151992-001	D- 3				

