

brother.

**SINGLE-CHAINE STITCH BUTTONING MACHINE**  
**KNOPFNÄHMASCHINE FÜR EINFACHKETTENSTITCH**  
**MACHINE A BOUTONNER A POINT CHAINETTE SIMPLE**  
**MAQUINA DE COSER BOTONES DE PUNTO DE CADENETA SIMPLE**



**CB3-B913**

**PARTS BOOK**  
**TEILEKATALOG**  
**LIVRE DES PIECES**  
**LIBRO DE REFERENCIA DE PIEZAS**



[www.PromElectroAvtomat.ru](http://www.PromElectroAvtomat.ru)



## Notes for using this parts book

1. If the symbol  is found in the "Parts No." column or the "Assembly No." column, refer to the different parts list on page 10.
2. The symbol  in the "Parts No." column indicates that the parts is not available for supply. If, however, there is a number in the "Assembly No." column, the parts can be ordered as an assembly. Please, therefore, order by using the assembly number.
3. This book was prepared based on information available in March, 1980.
4. Parts are subject to changes in design without prior notice.

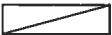

## Anmerkungen zum Gebrauch dieses Stücklistebuches

1. Dieses Zeichen  in der Spalte "Parts No. (Teilnummer)" oder "Assembly No. (Gerätesatznummer)" verweist auf die Gesonderte Stückliste auf Seite 10.
2. Dieses Zeichen  in der Spalte "Teilnummer" bedeutet, daß dieser Teil nicht lieferbar ist. Wenn jedoch in der Spalte "Gerätesatznummer" eine Nummer steht, kann dieser Teil als ein Geräteteilsatz bestellt werden. Bestellen Sie daher bitte mit dieser Gerätesatznummer.
3. Dieses Buch basiert auf den Informationen vom März, 1980.
4. Modelländerungen sind vorbehalten.

## Notes sur l'utilisation de ce manuel de pièces détachées

1. Si le symbole  se trouve dans la colonne "Parts No. (N° de pièce)" ou dans la colonne "Assembly No. (N° jeu de pcs)", veuillez vous référer à la liste de pièces annexe page 10.
2. Le symbole  dans la colonne "N° de pièce" signifie que la pièce ne peut être fournie. Si, dans la colonne "N° jeu de pcs", il y a un numéro de nomenclature, la pièce peut être commandée comme faisant partie d'un jeu de pièces. Donc, pour toute commande, veuillez spécifier le n° du jeu de pièces.
3. Ce manuel a été fait d'après les renseignements valables au mois de Mars 1980.
4. Les pièces peuvent être sujettes à des modifications sans préavis.

## Notas para usar este Libro de Piezas

1. De haber un símbolo  junto al "Parts No. (Número de Pieza)" o en la columna del "Assembly No. (Número de Juego)", habrá que mirar la lista de piezas separada de la página 10.
2. El símbolo , que se encuentra en la columna del "Número de Pieza", quiere decir que no se dispone de dicha pieza sola. Cuando, empero, hay un número en la columna del "Número de Juego", se podrá ordenar la pieza con todo el juego. Por lo tanto, será mejor hacer el pedido recurriendo al número del juego respectivo.
3. Este libro ha sido compilado basándose en los datos de que se disponía en marzo de 1980.
4. Las piezas quedan sujetas a cambios de diseño sin aviso previo.

## CONTENTS

A. Machine Body .....	1
B. Needle Bar and Driving Clutch Mechanism .....	2
C. Driving Clutch and Brake Mechanism .....	3
D. Feed Mechanism .....	4
E. Threading Mechanism .....	5
F. Button Clamp Mechanism .....	6
Z. Accessories .....	7
a. Shank Attachment (Special Order Parts).....	8
b. Snap Clamp (Special Order Parts).....	9
DIFFERENT PARTS LIST .....	10
INDEX .....	11

# A. Machine Body

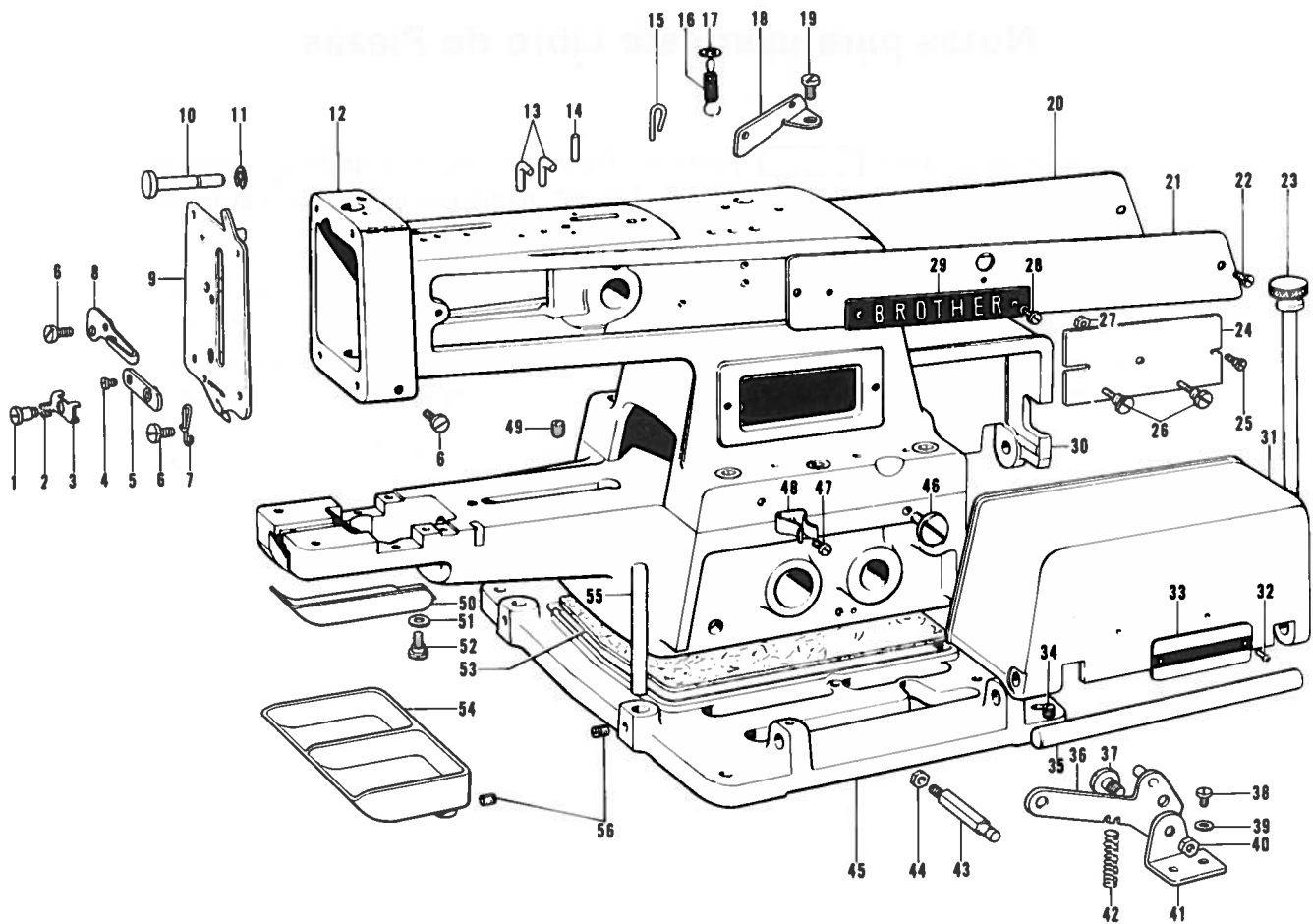

Ref. No.	Name of Parts	Q'ty	Parts No.	Assembly No.	Ref. No.	Name of Parts	Q'ty	Parts No.	Assembly No.
A-1	Screw 3.18	1	112301-0-01		A-29	Name Plate "BROTHER"	2		
A-2	Spring	1	142361-0-00		A-30	Bed Cover Assembly (Left)	1	154225-0-01	
A-3	Needle Thread Guard	1	112300-0-01		A-31	Bed Cover Assembly (Right)	1	154224-0-01	
A-4	Screw 3.57	1	116323-0-01		A-32	Pin	2		
A-5	Sub Tension Plate	1	142360-0-01		A-33	Model Plate	1		
A-6	Screw 4.76 x 10	5	009711-0-12		A-34	Screw 5.56	1	013750-6-10	
A-7	Face Plate Thread Guide	1	115212-1-01		A-35	Bed Cover Shaft	2	114984-0-00	
A-8	Thread Guide	1	151881-0-01		A-36	Clutch Driving Lever	1	142307-0-01	
A-9	Face Plate	1	117879-0-01		A-37	Screw 5.56	1	115268-0-01	
A-10	Thread Releaser	1	142672-0-01		A-38	Screw 4.76 x 12	2	009711-2-12	
A-11	Stop Ring E3	1	048030-3-42		A-39	Washer 4.76	2	025710-2-32	
A-12	Arm-Bed	1			A-40	Nut 5.56	1	021750-1-03	
A-13	Pin	2	115192-0-01		A-41	Clutch Drive Lever Plate	1	115025-0-01	
A-14	Pin	1	115189-0-01		A-42	Spring	1	115026-0-01	
A-15	Main Tension Thread Guide	1	115184-0-01		A-43	Spring Hook	1	115022-0-01	
A-16	Spring	1	115137-0-01		A-44	Nut 4.37	1	102571-0-03	
A-17	Spring Hook	1	115138-0-01		A-45	Bed Base	1		
A-18	Thread Retainer	1	115183-1-01		A-46	Screw 5.56	1	115268-0-01	
A-19	Screw 4.76 x 7	1	009710-7-12		A-47	Screw 4.37	2	009680-7-13	
A-20	Arm Cover (Left)	1	114979-1-01		A-48	Bed Cover Stop Spring	2	114985-0-01	
A-21	Arm Cover (Right)	1	114978-1-01		A-49	Screw 5.56	1	013751-0-10	
A-22	Screw 4.37	4	106629-0-01		A-50	Looper Cover	1	115275-0-01	
A-23	Bolt	1	114986-0-01		A-51	Washer	1	105329-0-01	
A-24	Rear Cover	1	114976-0-01		A-52	Screw 4.37	1	114988-0-01	
A-25	Screw 3.57	1	114977-0-01		A-53	Felt	1	114982-0-00	
A-26	Screw 3.57	2	100008-0-03		A-54	Button Tray	1	115270-0-01	
A-27	Nut 3.57	1	021670-1-03		A-55	Button Tray Leg	2	115160-0-01	
A-28	Screw 2.38	4			A-56	Screw 6.35	4	013770-6-10	

## B. Needle Bar and Driving Clutch Mechanism

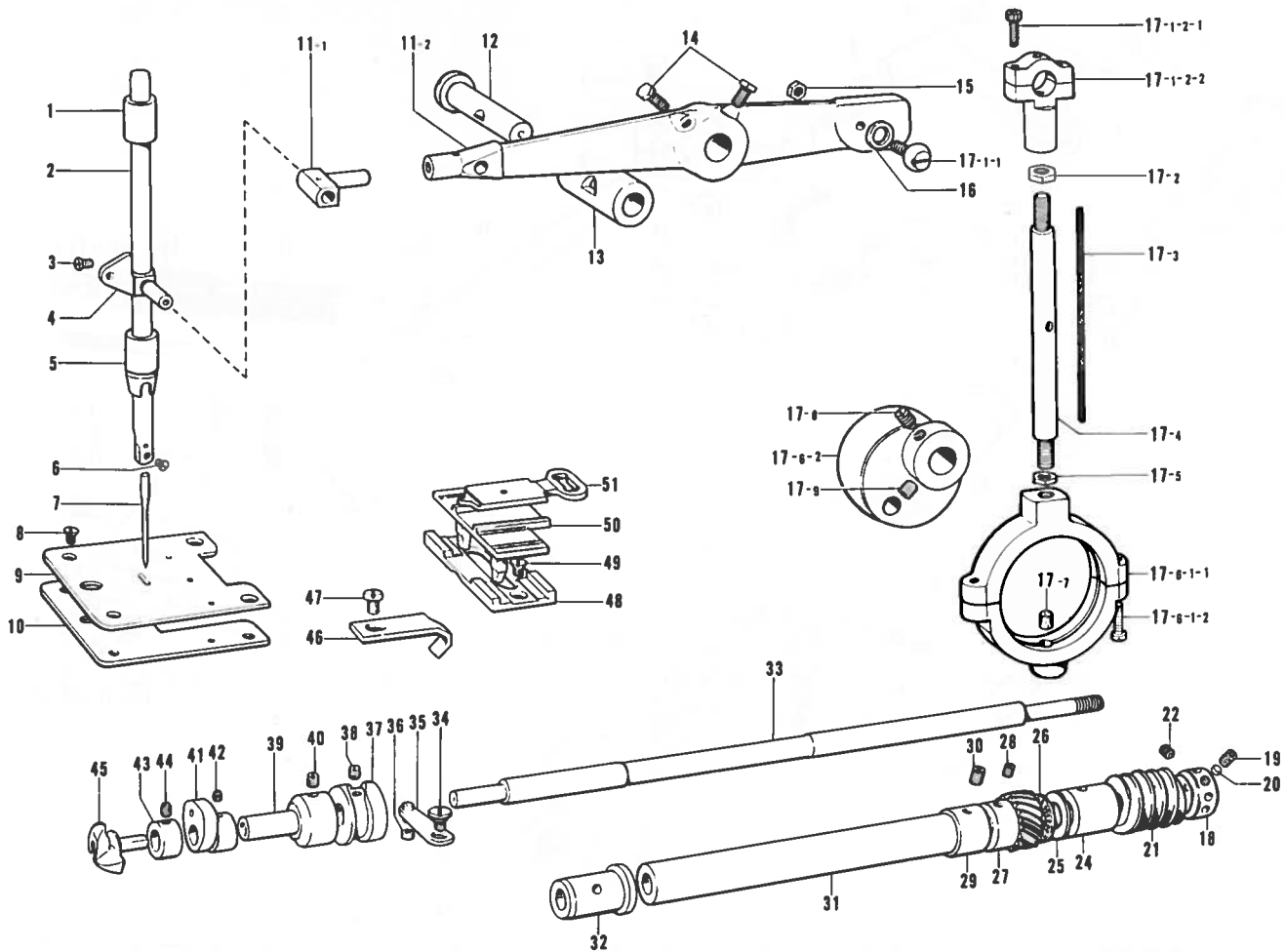

Ref. No.	Name of Parts	Q'ty	Parts No.	Assembly No.	Ref. No.	Name of Parts	Q'ty	Parts No.	Assembly No.
B-1	Needle Bar Bushing (Upper)	1	115051-0-00		B-18	Fastening Ring	1	114973-0-01	
B-2	Needle Bar	1	115050-0-01		B-19	Screw 6.35	1	014770-6-22	
B-3	Screw 3.57 x 8	1	009670-8-12		B-20	Washer	1	101028-0-00	
B-4	Needle Bar Thread Guide	1	153808-0-01		B-21	Worm	1		
B-5	Needle Bar Bushing (Lower)	1	115052-0-00		B-22	Screw 6.35	2	014770-6-22	
B-6	Screw 3.18	1	140553-1-01		B-24	Lower Shaft Bushing (Rear)	1	115059-0-00	
B-7	Needle TQ x 1	1	115053-0-16		B-25	Washer	1	115007-0-01	
B-8	Screw 4.37 x 10	4	005681-0-12		B-26	Thrust Bearing	1	115008-0-00	
B-9	Needle Plate	1	144711-0-01		B-27	Lower Shaft Gear	1	115060-0-01	
B-10	Needle Plate Subordinate	1	115055-0-01		B-28	Screw 6.35	2	014770-6-22	
B-11-1	Needle Bar Bracket	1	115048-0-01	B-11 Needle Bar Driving Lever Assembly 182350-0-01	B-29	Collar	1	115063-0-01	
B-11-2	Needle Bar Driving Lever	1			B-30	Screw 6.35	2	014770-6-22	
B-12	Needle Bar Driving Lever Shaft	1	115046-0-01		B-31	Distance Collar	1	115064-0-01	
B-13	Bushing	1	115047-0-01		B-32	Lower Shaft Bushing (Front)	1	115058-0-00	
B-14	Bolt 5.56 x 14	2	017751-4-12		B-33	Lower Shaft	1	115057-0-01	
B-15	Nut 5.56	1	021750-1-03		B-34	Screw 4.76	1	115077-0-01	
B-16	Washer	1	144657-0-00		B-35	Thread Handler Link	1	115073-0-01	
B-17-1-1	Round Joint	1		B-17-1 Upper Crank Rod Assembly 181313-0-01	B-36	Thread Handler Link Roller	1	115076-0-01	
B-17-1-2-1	Screw 4.37 x 14	2	148425-0-01		B-17-1-2 Upper Crank Rod Assembly 181314-0-01	B-37	Grooved Cam	1	115065-0-00
B-17-1-2-2	Upper Crank Rod	1		B-38		Screw 5.56	2	110124-0-01	
B-17-2	Nut 7.14	1	021800-1-03	B-17 Crank Rod Assembly 144700-1-01	B-39	Shaft	1	115066-0-00	
B-17-3	Wick	1	144701-0-00		B-40	Screw 5.56	2	013750-6-10	
B-17-4	Crank Rod	1	115041-0-01		B-41	Triangular Cam	1	115067-0-01	
B-17-5	Nut 7.14	1	115042-0-01		B-42	Screw 4.37	2	151601-0-01	
B-17-6-1-1	Lower Crank Rod	1		B-17-6 Lower Crank Rod Assembly 182339-0-01	B-43	Collar	1	115068-0-01	
B-17-6-1-2	Screw 4.37	2	142658-0-01		B-44	Screw 4.37	1	151602-0-01	
B-17-6-2	Needle Bar Driving Cam	1		B-17-6 Lower Crank Rod Assembly 181312-0-01	B-45	Rotary Loper	1	115069-0-01	
B-17-7	Felt	1	107155-0-01		B-46	Needle Guide	1	115054-1-01	
B-17-8	Screw 6.35	1	015770-8-12		B-47	Screw 4.76 x 6	1	009710-6-12	
B-17-9	Screw 6.35	1	014770-6-22		B-48	Thread Handler Bracket	1	115070-0-00	
					B-49	Screw 3.57 x 6	2	003670-6-12	
					B-50	Guide Plate	1	115071-0-01	
					B-51	Thread Handler	1	115072-0-01	



## C. Driving Clutch and Brake Mechanism

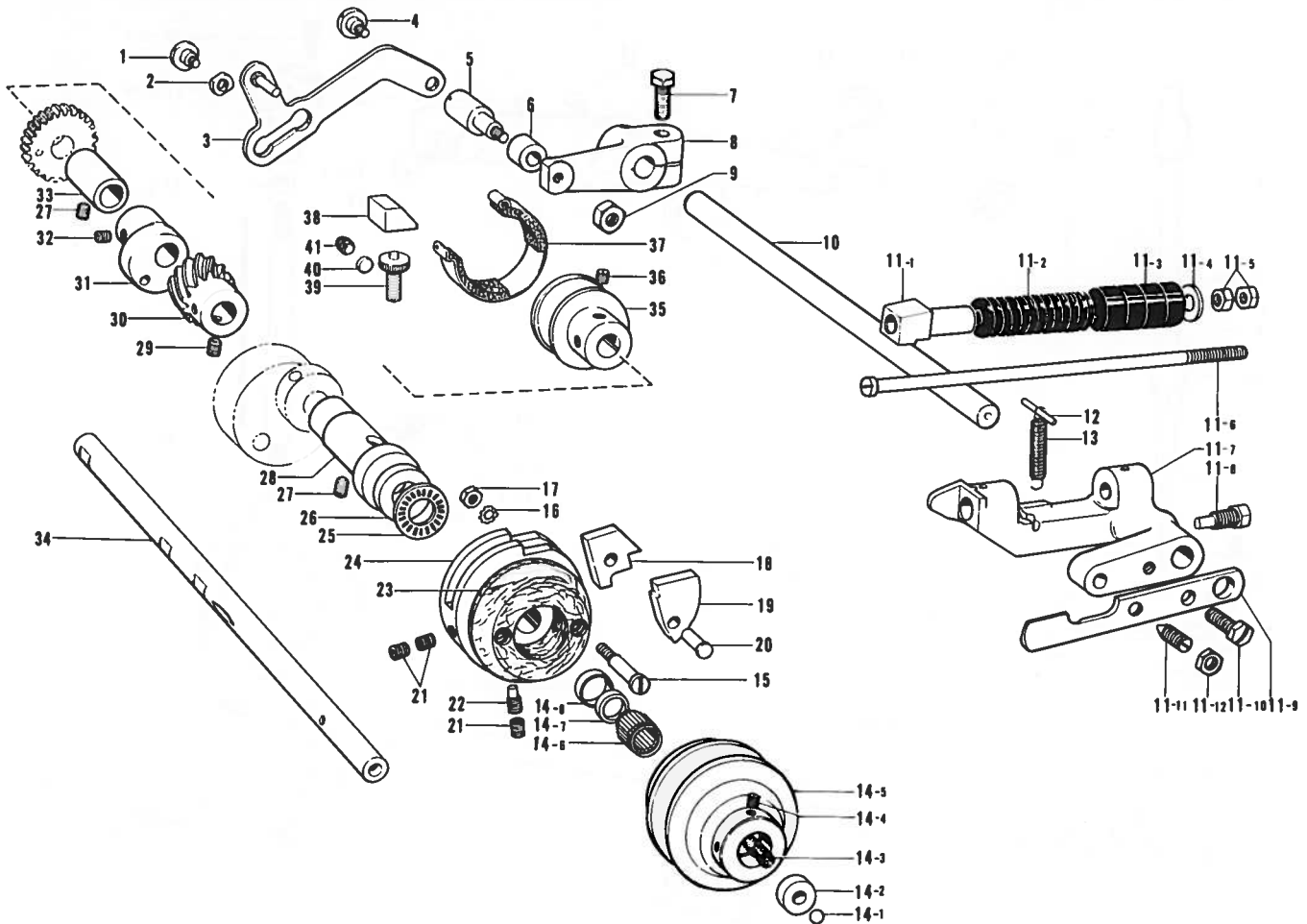

Ref. No.	Name of Parts	Q'ty	Parts No.	Assembly No.	Ref. No.	Name of Parts	Q'ty	Parts No.	Assembly No.
C- 1	Screw 4.76	1	144523-0-01		C-14- 7	Grease Seal	1	114993-0-00	C-14 Pulley Assembly 114990-0-01
C- 2	Slide Block	1	144524-0-00		C-14- 8	Grease Seal Cap	1	114994-0-01	
C- 3	Brake Lever	1	144520-0-01		C-15	Screw 5.56	2	114999-0-01	
C- 4	Screw 4.37	1	144526-0-01		C-16	Washer	2	115000-0-00	
C- 5	Stud	1	144525-0-01		C-17	Nut 5.56	2	021750-1-03	
C- 6	Roller	1	105872-0-01		C-18	Brake Cam Segment	1	115002-0-01	
C- 7	Bolt 7.94 x 22	1	017822-2-13		C-19	Flange Cam Segment	1	115003-0-01	
C- 8	Stitch Regulating Lever	1	115027-1-01		C-20	Pin	2	115004-0-01	
C- 9	Nut 4.76	1	110161-0-04		C-21	Screw 7.94	3	014821-0-22	
C-10	Clutch Body Shaft	1	115013-0-01		C-22	Set Screw	1	149996-0-01	
C-11- 1	Stopper Bracket	1	115015-1-01	C-11 Clutch Body Assembly 144747-2-01	C-23	Clutch Plate	1	114998-0-00	
C-11- 2	Washer	3	115017-0-01		C-24	Stop Cam	1	149995-0-01	
C-11- 3	Cushion Rubber	4	115018-0-01		C-25	Thrust Bearing	1	115008-0-00	
C-11- 4	Washer 7.14	1	025800-3-33		C-26	Washer	1	115007-0-01	
C-11- 5	Nut 7.14	2	021800-1-03		C-27	Screw 4.76	2	013711-0-10	
C-11- 6	Stopper Shaft	1	115016-0-01		C-28	Bushing (Right)	1	115214-1-00	
C-11- 7	Clutch Body	1			C-29	Screw 6.35	2	014770-6-22	
C-11- 8	Set Screw	1	115014-0-01		C-30	Spiral Gear	1	115061-0-01	
C-11- 9	Ball Presser Plate	1	115010-0-01		C-31	Cam	1	115124-0-01	
C-11-10	Bolt 6.35	1	115011-0-01		C-32	Screw 6.35	2	014770-6-22	
C-11-11	Screw 6.35	1	115012-0-01		C-33	Bushing (Left)	1	115215-0-00	
C-11-12	Nut 6.35	1	150554-0-01		C-34	Driving Shaft	1	114989-0-01	
C-12	Pin	1	115021-0-01	C-35	Brake Drum	1	144509-0-00		
C-13	Spring	1	115020-0-01	C-36	Screw 5.95	2	013750-6-10		
C-14- 1	Steel Ball 5/16	1	071079-4-50	C-37	Brake Shoe	1	144510-0-01		
C-14- 2	Ball Holder	1	114995-0-01	C-38	Brake Adjuster	1	144519-0-01		
C-14- 3	Spring	1	114997-0-01	C-39	Brake Adjuster Knob	1	144518-0-01		
C-14- 4	Screw 4.76	2	013710-7-12	C-40	Washer	1	107793-0-00		
C-14- 5	Pulley	1	114991-0-01	C-41	Screw 5.95	1	151604-0-01		
C-14- 6	Bearing	2	114992-0-00						

## D. Feed Mechanism

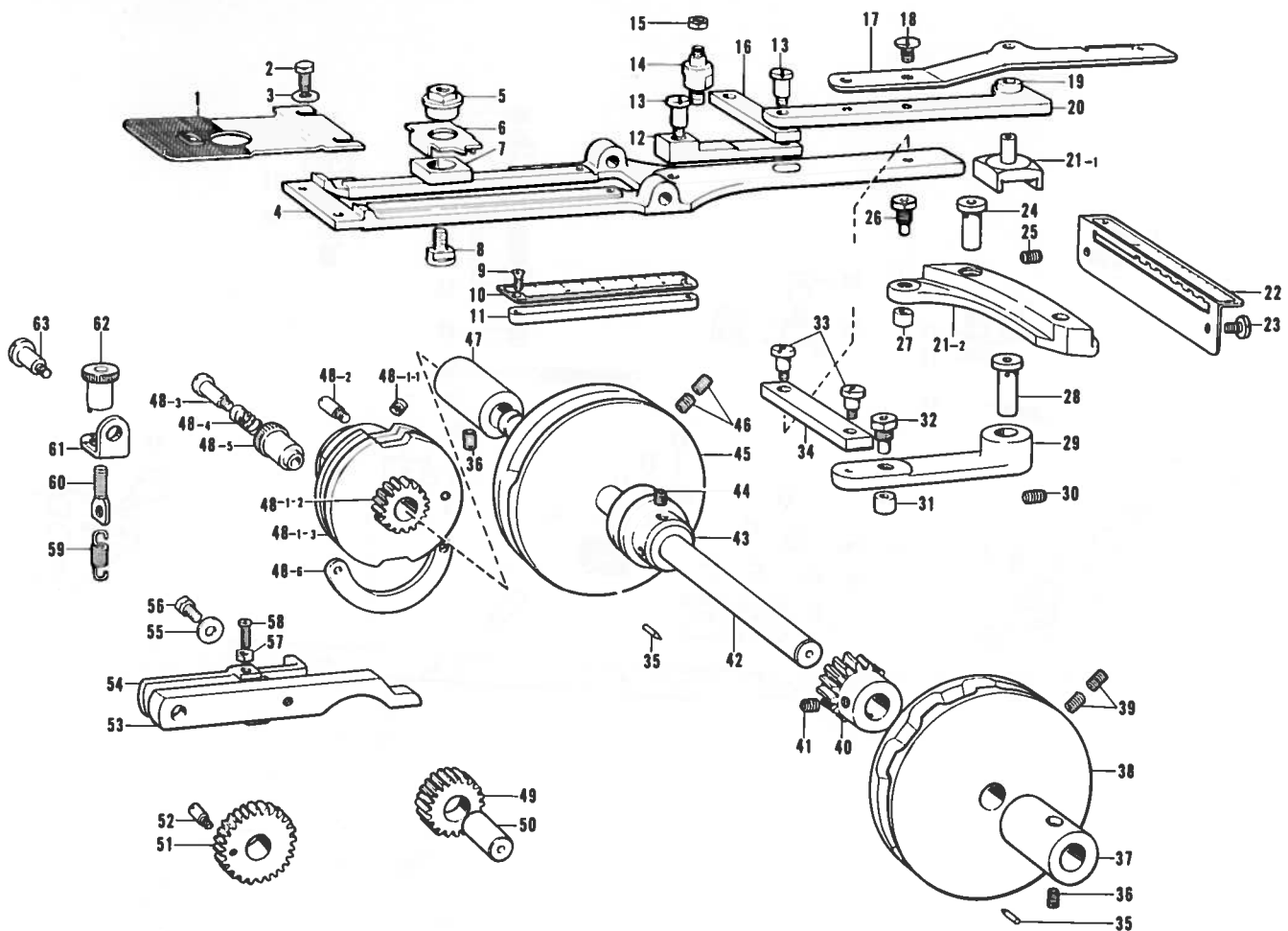

Ref. No.	Name of Parts	Q'ty	Parts No.	Assembly No.	Ref. No.	Name of Parts	Q'ty	Parts No.	Assembly No.
D-1	Feed Plate (A)	1	144659-1-01		D-35	Pin	2	114980-0-01	
D-2	Bolt 4.76 x 7	2	146360-0-02		D-36	Screw 4.76	2	013711-0-10	
D-3	Washer	2	146354-0-01		D-37	Cam Shaft Bushing (Right)	1	115080-0-00	
D-4	Feed Bracket	1	115087-0-01		D-38	Transverse-Feed Cam	1		
D-5	Transverse-Feed Adjusting Nut	1	115091-0-01		D-39	Screw 6.35	4	014770-6-22	
D-6	Transverse-Feed Plate	1	115090-0-01		D-40	Worm Wheel	1		
D-7	Transverse-Feed Slide Block	1	115088-0-01		D-41	Screw 6.35	2	014770-6-22	
D-8	Screw	1	115089-0-01		D-42	Cam Shaft	1	115078-0-01	
D-9	Screw 3.18	2	117291-0-01		D-43	Button Clamp Driving Link Guide	1	115131-1-01	
D-10	Transverse-Feed Length Indicator	1	115092-0-01		D-44	Screw 6.35	2	014770-6-22	
D-11	Supporting Plate	1	115093-0-01		D-45	Back & Forth Feed Cam	1	115084-0-00	
D-12	Back & Forth Feed Link	1	115100-0-01		D-46	Screw 6.35	4	014770-6-22	
D-13	Screw 4.76	2	115101-0-01		D-47	Cam Shaft Bushing (Left)	1	115079-0-00	
D-14	Stud	1	115102-0-01		D-48-1-1	Screw 6.35	2	014770-6-22	D-48-1 Stitch Control Cam Assembly 115109-0-01
D-15	Nut 4.76	1	021710-1-03		D-48-1-2	Stitch Control Cam Gear	1		
D-16	Feed Link	1	115094-0-01		D-48-1-3	Stitch Control Cam	1		
D-17	Back & Forth Feed Adjusting Lever	1	115105-0-01		D-48-2	Screw 4.37	1	115113-0-01	D-48 Stitch Control Assembly 180982-0-01
D-18	Screw 4.37	2	009680-6-12		D-48-3	Screw 4.37	1	115116-0-01	
D-19	Bushing	1	115104-0-01		D-48-4	Spring	1	115115-0-01	
D-20	Back & Forth Feed Connector	1	115103-0-01		D-48-5	Stitch Control Knob	1	115114-0-01	
D-21-1	Back & Forth Feed Slide Block	1	115106-0-01	D-21 Back & Forth Feed Adjusting Assembly 180910-0-01	D-48-6	Stitch Control Cam Segment	1	115112-0-01	
D-21-2	Back & Forth Feed Lever	1			D-49	Stitch Changing Gear	1	115117-0-00	
D-22	Back & Forth Feed Length Indicator	1	115108-0-01		D-50	Shaft	1	115118-0-01	
D-23	Screw 4.76 x 7	2	009710-7-12		D-51	Stitch Changing Gear	1	115119-0-01	
D-24	Feed Lever Shaft	1	115099-0-01		D-52	Pin	1	115120-0-01	
D-25	Screw 5.95	1	117685-0-01		D-53	Lever For 32-Stitches (Major)	1	115121-1-01	
D-26	Stud	1	115097-0-01		D-54	Lever For 32-Stitches (Minor)	1	147114-0-01	
D-27	Roller	1	115098-0-01		D-55	Washer 4.76	1	025710-2-33	
D-28	Feed Lever Shaft	1	115099-0-01		D-56	Bolt 4.76	1	117363-0-02	
D-29	Transverse-Feed Lever	1	115096-0-00		D-57	Nut 3.18	1	021660-1-02	
D-30	Screw 5.95	1	151605-0-02		D-58	Screw 3.18 x 12	1	009661-2-13	
D-31	Roller	1	115098-0-01		D-59	Spring	1	144516-0-01	
D-32	Stud	1	115097-0-01		D-60	Spring Hook	1	144515-0-01	
D-33	Screw 4.76	2	115095-0-01		D-61	Brake Spring Plate	1	144513-0-01	
D-34	Feed Link	1	115094-0-01		D-62	Screw	1	144517-0-01	
					D-63	Screw 4.76	1	144514-0-01	

## E. Threading Mechanism

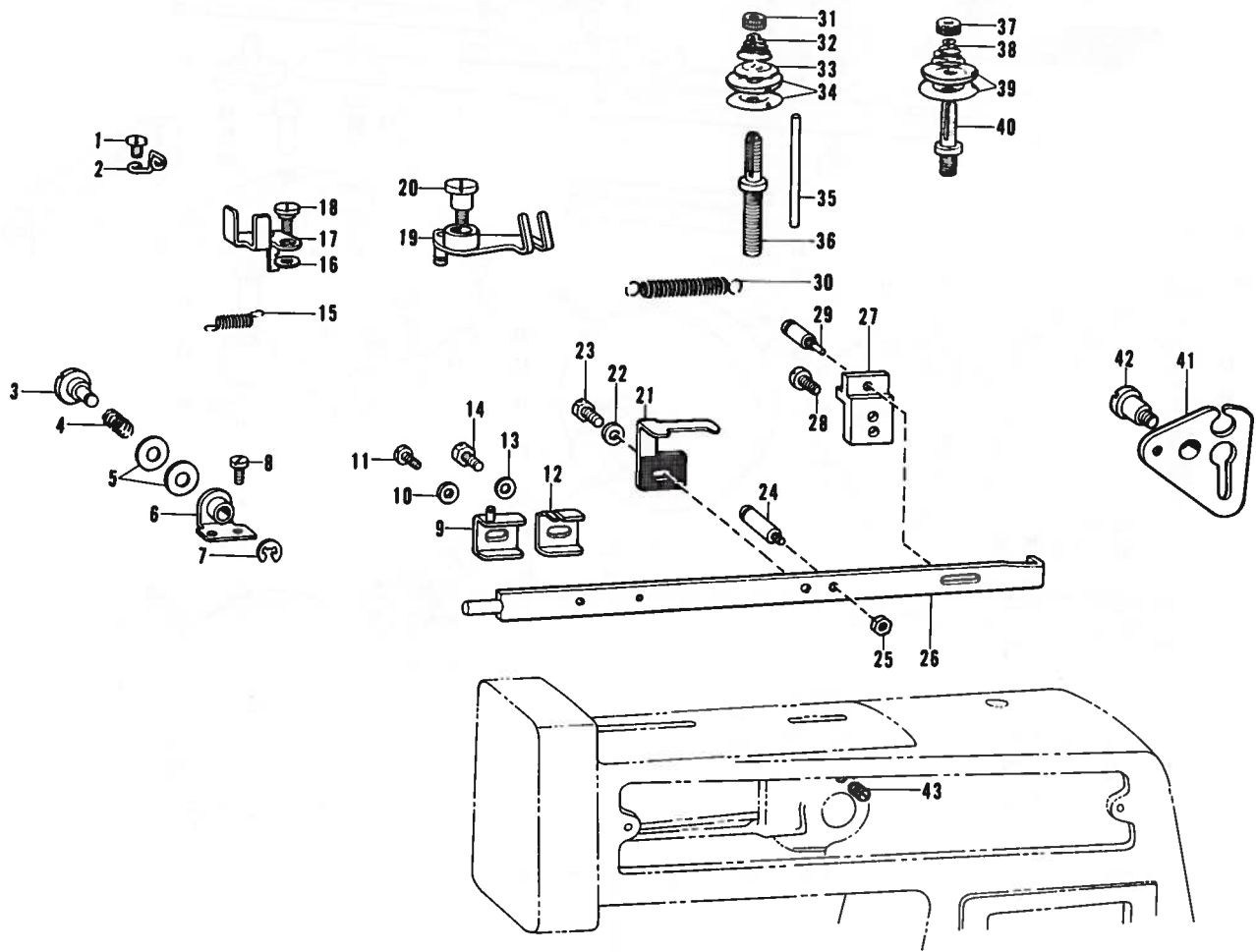

Ref. No.	Name of Parts	Q'ty	Parts No.	Assembly No.	Ref. No.	Name of Parts	Q'ty	Parts No.	Assembly No.
E-1	Screw 4.76 x 10	1	009711-0-12		E-23	Bolt 4.76	1	117363-0-02	
E-2	Arm Thread Guide	1	115204-0-01		E-24	Spring Hook	1	115177-0-01	
E-3	Thread Presser Shaft	1	144673-0-01		E-25	Nut 3.18	1	021660-1-02	
E-4	Thread Presser Spring	1	144674-0-00		E-26	Thread Release Connecting Bar	1	115173-0-01	
E-5	Pre-Tension Disc	2	100546-0-01		E-27	Guide Bracket	1	115174-0-01	
E-6	Indicator Plate	1	144672-0-01		E-28	Screw 4.76 x 12	2	009711-2-13	
E-7	Stop Ring E3	1	048030-3-46		E-29	Pin	1	115175-0-01	
E-8	Screw 4.76 x 10	2	009711-0-12		E-30	Spring	1	115176-0-01	
E-9	Presser Lever Bracket	1	115180-0-01		E-31	Tension Control Nut	1	100136-0-01	
E-10	Washer	1	146354-0-01		E-32	Tension Spring	1	104525-0-01	
E-11	Screw 4.76 x 7	1	009710-7-13		E-33	Presser For Tension Disc	1	100134-0-01	
E-12	Adjuster	1	115179-0-01		E-34	Tension Disc	2	115187-0-01	
E-13	Washer	1	146354-0-01		E-35	Pin	1	115191-0-01	
E-14	Bolt 4.76	1	117363-0-02		E-36	Tension Stud	1	115190-0-01	
E-15	Spring	1	144671-0-01		E-37	Tension Control Nut	1	100136-0-01	
E-16	Washer 6	1	025060-1-32		E-38	Spring	1	115188-0-01	
E-17	Thread Presser Lever	1	144669-0-01		E-39	Tension Disc	2	115187-0-01	
E-18	Screw 5.56	1	144670-0-01		E-40	Main Tension Stud	1	115186-0-01	
E-19	Thread Take-up Lever	1	144486-0-01		E-41	Thread Release Cam	1	115171-0-01	
E-20	Screw 5.56	1	110249-0-01		E-42	Screw 6.35	1	115172-0-01	
E-21	Thread Release Lever	1	115178-0-01		E-43	Screw 4.76	1	013719-4-12	
E-22	Washer	1	146354-0-01						



# F. Button Clamp Mechanism

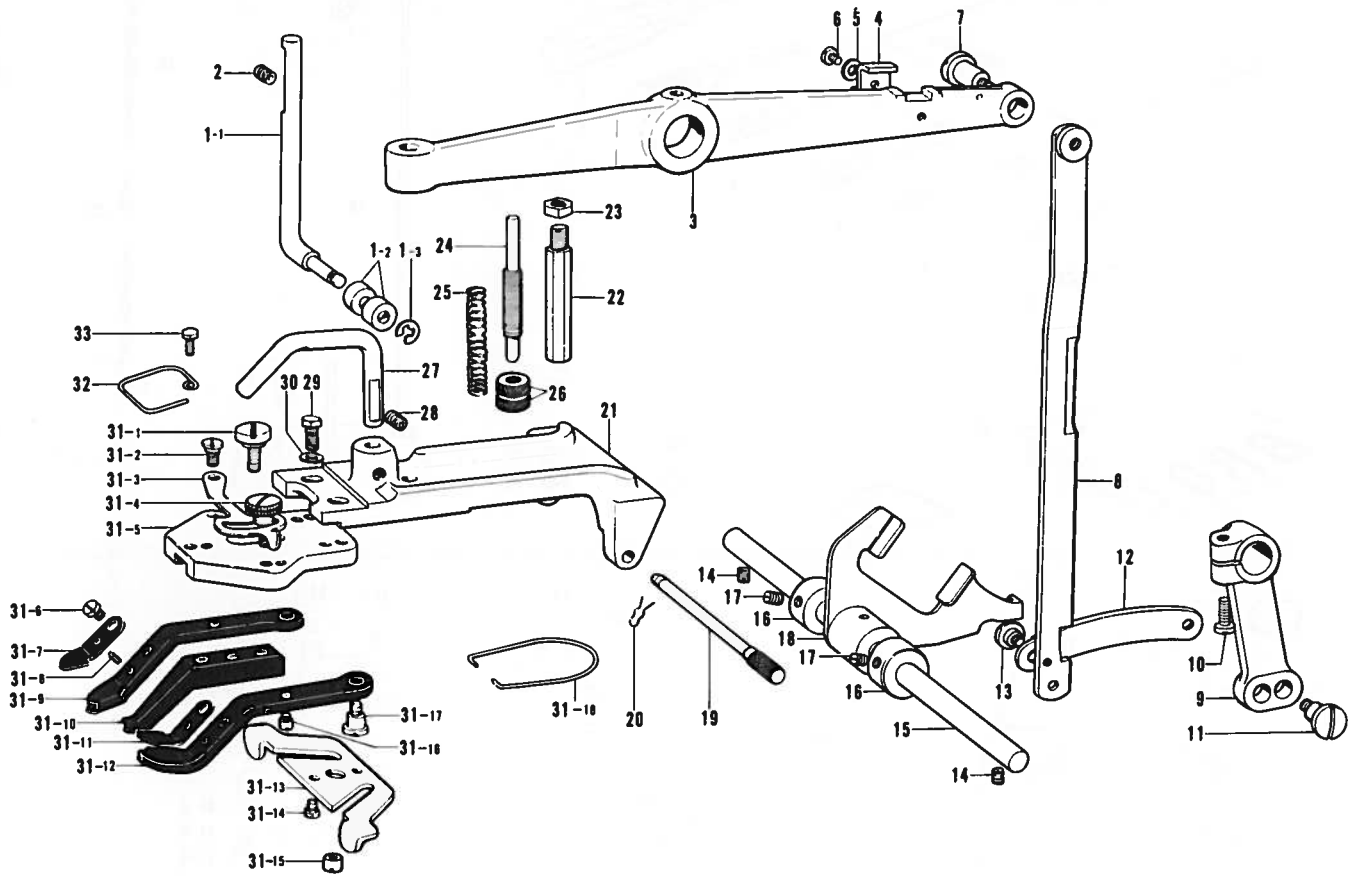

Ref. No.	Name of Parts	Q'ty	Parts No.	Assembly No.	Ref. No.	Name of Parts	Q'ty	Parts No.	Assembly No.
F- 1- 1	Button Clamp Lifter	1	115139-0-01	F-1 Clamp Lifter Assembly 142308-0-01	F-25	Spring	1	115147-0-01	
F- 1- 2	Roller	2	107744-0-01		F-26	Tension Control Nut	2	146994-0-01	
F- 1- 3	Stop Ring E3	1	048030-3-42		F-27	Hook	1	115146-0-01	
F- 2	Screw 6.35	1	014770-6-22	F-28	Screw 6.35	1	014770-6-22		
F- 3	Button Clamp Lifting Lever	1	115135-1-01	F-29	Bolt 4.76 x 14	2	017711-4-12		
F- 4	Stopper	1	117873-1-01	F-30	Washer	2	146354-0-01		
F- 5	Washer	1	146354-0-01	F-31- 1	Screw 3.57	1	115161-0-01		
F- 6	Screw 4.37	1	107407-0-03	F-31- 2	Screw 4.37	1	115165-0-01		
F- 7	Screw 4.76	1	115101-0-01	F-31- 3	Button Clamp Adjusting Plate	1	115164-0-01		
F- 8	Button Clamp Driving Connector	1	115134-1-01	F-31- 4	Screw 4.37	1	115166-0-01		
F- 9	Button Clamp Driving Lever	1	115128-1-00	F-31- 5	Button Clamp Bracket	1	115151-0-00		
F-10	Screw 5.56 x 16	1	009751-6-12	F-31- 6	Screw 4.37 x 4.5	2	009689-4-12		
F-11	Screw 4.76	1	115132-0-01	F-31- 7	Spring	1	150398-0-01		
F-12	Button Clamp Driving Link	1	115130-0-01	F-31- 8	Spring Pin	2	047250-6-42		
F-13	Screw 4.76	1	115133-0-01	F-31- 9	Button Clamp (Left)	1	150397-1-01	F-31 Button Clamp Assembly 150403-1-01	
F-14	Screw 5.56	2	013751-0-10	F-31-10	Button Clamp (Middle)	1	150402-0-01		
F-15	Button Clamp Driving Shaft	1	115126-0-01	F-31-11	Spring	1	150401-0-01		
F-16	Collar	2	115127-0-01	F-31-12	Button Clamp (Right)	1	150399-1-01		
F-17	Screw 4.76	4	013710-5-10	F-31-13	Button Clamp Plate	1	115269-0-01		
F-18	Button Clamp Driving Fork	1	115125-0-01	F-31-14	Screw 3.57 x 8	2	009670-8-12		
F-19	Button Clamp Holder Bar	1	115144-0-01	F-31-15	Nut 3.57	1	115162-0-01		
F-20	Snap	1	115145-0-01	F-31-16	Pin	2	115156-0-01		
F-21	Button Clamp Holder	1	115143-2-01	F-31-17	Screw 4.76	2	115158-0-01		
F-22	Stopper	1	115149-0-01	F-31-18	Spring	1	115163-0-01		
F-23	Nut 5.56	1	107282-0-02	F-32	Finger Guard	1			
F-24	Screw	1	115148-1-01	F-33	Bolt 4.76 x 7	1			

## Z. Accessories

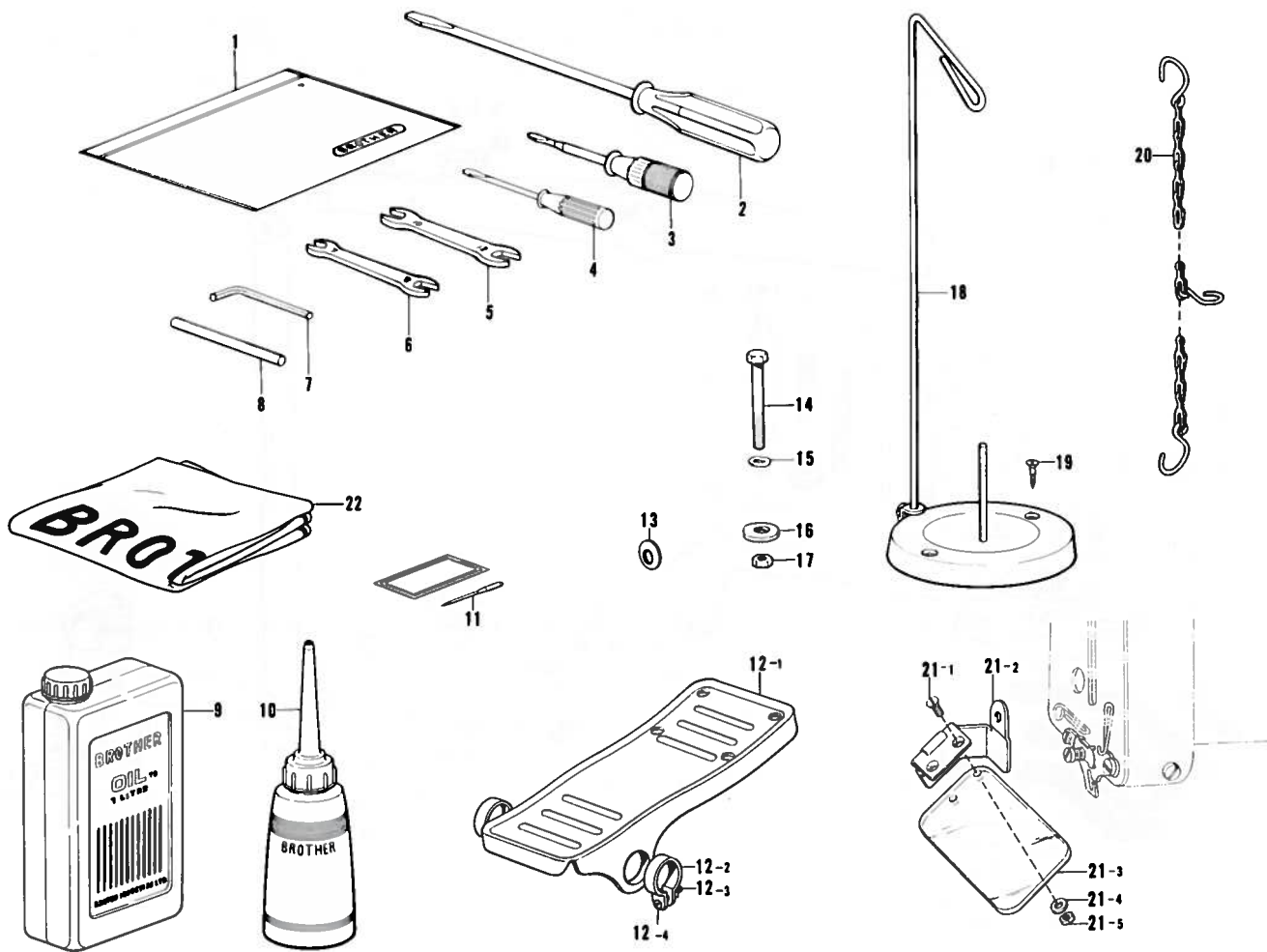

Ref. No.	Name of Parts	Q'ty	Parts No.	Assembly No.	Ref. No.	Name of Parts	Q'ty	Parts No.	Assembly No.
Z- 1	Vinyl Bag		122991-0-01		Z-13	Washer		115017-0-01	
Z- 2	Screw Driver 5.5 x 190		101572-1-01		Z-14	Bolt 6 x 63		144543-0-01	
Z- 3	Screw Driver 3.4 x 70		118837-0-01		Z-15	Washer		025060-2-32	
Z- 4	Screw Driver 2.6 x 70		105344-0-01		Z-16	Washer		115947-0-01	
Z- 5	Spanner 10 x 12		107780-0-01		Z-17	Nut 6		021060-1-02	
Z- 6	Spanner 7 x 8		142205-0-01		Z-18	Spool Stand		109854-0-01	
Z- 7	Spanner 3		142721-0-01		Z-19	Screw 4.5 x 32		100447-0-01	
Z- 8	Worm Adjusting Bar		115123-0-01		Z-20	Chain Assembly		142656-0-01	
Z- 9	Oil Tank		145277-1-03		Z-21- 1	Screw 3.18 x 7		005660-7-13	
Z-10	Oiler		114483-0-01		Z-21- 2	Eye Guard Hinge Assembly		143964-0-01	Z-21 Eye Guard Assembly
Z-11	Needle Assembly		181236-0-01		Z-21- 3	Eye Guard		143966-0-01	
Z-12- 1	Pedal		117437-1-01	Z-12 Pedal Assembly 116185-2-01	Z-21- 4	Washer 3.18		025660-2-32	
Z-12- 2	Pedal Stopper		116016-0-01		Z-21- 5	Nut 3.18		021660-1-03	
Z-12- 3	Nut 4		021400-1-06		Z-22	Head Cover		144224-0-01	
Z-12- 4	Screw 4		001401-4-16						

\*The details of included accessories are subject to change.

\*Les détails des accessoires inclus sont sujets à des changements.

\*Änderungen in der Aufstellung der mitgelieferten Zubehöre sind vorbehalten.

\*Los detalles de los accesorios incluidos pueden variar.

## a. Shank Attachment (Special Oder Parts)

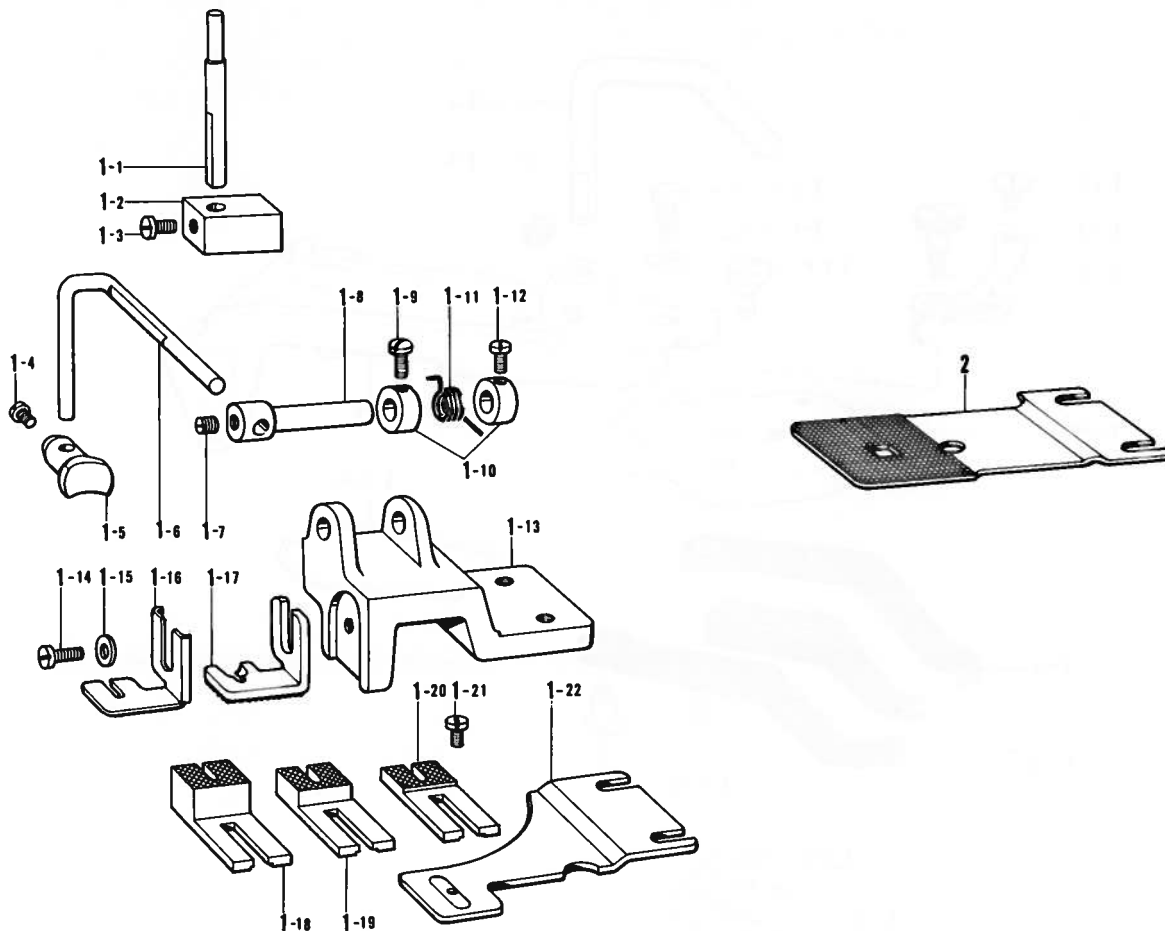



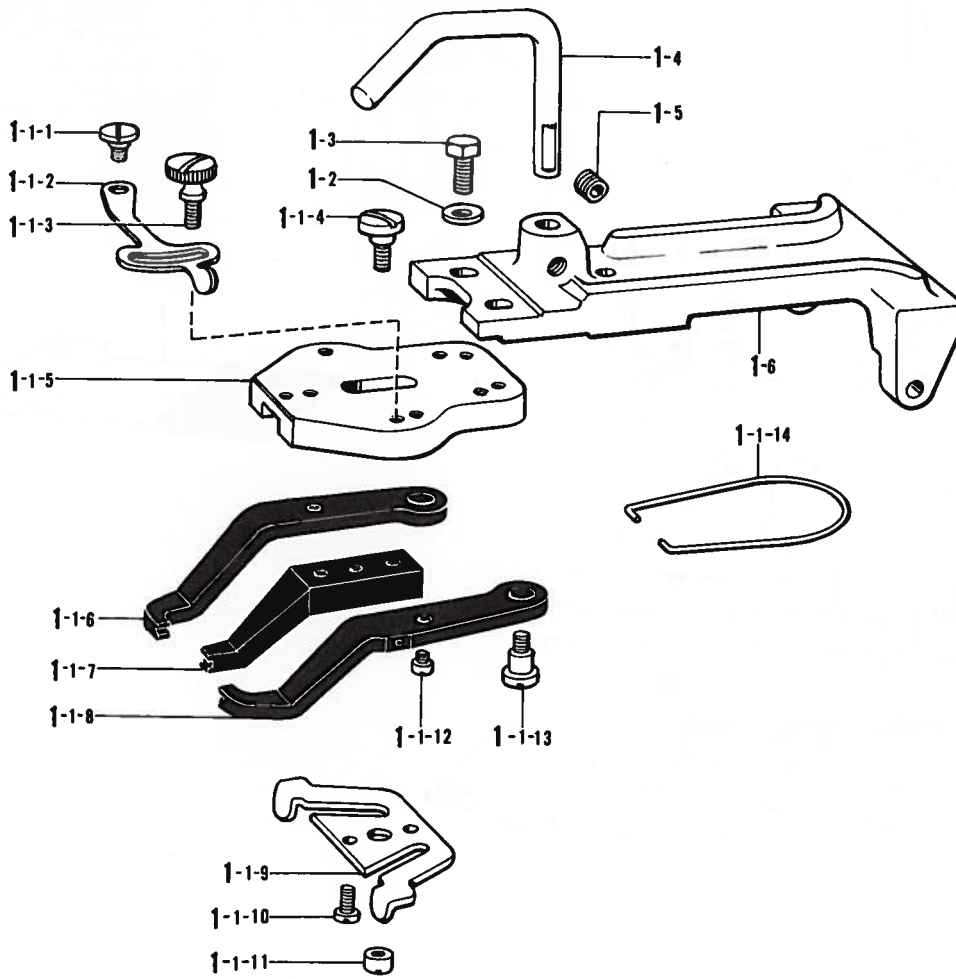

Ref. No.	Name of Parts	Q'ty	Parts No.	Assembly No.	Ref. No.	Name of Parts	Q'ty	Parts No.	Assembly No.
a- 1- 1	Button Presser Arm Lifter Bar	1	142684-0-01	a-1 Shank Button Clamp Assembly 142570-0-01	a- 1-13	Shank Button Clamp Bracket	1		a-1 Shank Button Clamp Assembly 142570-0-01
a- 1- 2	Button Presser Arm Lifter	1	142683-0-01		a- 1-14	Screw 3.57 x 8	1	009670-8-12	
a- 1- 3	Screw 4.37	1	120990-0-01		a- 1-15	Washer	1	102707-0-03	
a- 1- 4	Screw 4.37	1	120990-0-01		a- 1-16	Button Clamp (A)	1	142677-0-01	
a- 1- 5	Button Presser	1	142680-0-01		a- 1-17	Button Clamp (B)	1	142678-0-01	
a- 1- 6	Button Presser Arm	1	142679-0-01		a- 1-18	Cloth Receiver (Large)	1	142688-0-01	
a- 1- 7	Screw 4.76	1	013719-4-12		a- 1-19	Cloth Receiver (Middle)	1	142687-0-01	
a- 1- 8	Button Presser Stud	1	142681-0-01		a- 1-20	Cloth Receiver (Small)	1	142686-0-01	
a- 1- 9	Screw 3.57 x 7	1	009670-7-12		a- 1-21	Screw 3.57 x 5	1	001670-5-12	
a- 1-10	Collar	2	142706-0-01		a- 1-22	Shank Button Feed Plate	1	142685-0-01	
a- 1-11	Spring	1	142682-0-01		a- 2	Feed Plate (B)	1	115085-0-01	
a- 1-12	Screw 3.57 x 5	1	009670-5-12						

## b. Snap Clamp (Special Oder Parts)

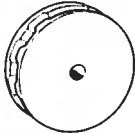
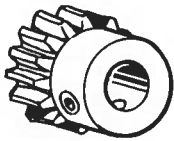

Ref. No.	Name of Parts	Q'ty	Parts No.	Assembly No.	Ref. No.	Name of Parts	Q'ty	Parts No.	Assembly No.
b-1-1- 1	Screw 4.37	1	115165-0-01	b-1-1 Snap Button Clamp Assembly 118538-0-01	b-1-1-11	Nut 3.57	1	115162-0-01	b-1-1 Snap Button Clamp Assembly 118538-0-01
b-1-1- 2	Button Clamp Adjusting Plate	1	115164-0-01		b-1-1-12	Pin	2	115156-0-01	
b-1-1- 3	Screw 4.37	1	115166-0-01		b-1-1-13	Screw 4.76	2	115158-0-01	
b-1-1- 4	Screw 3.57	1	115161-0-01		b-1-1-14	Spring	1	115163-0-01	
b-1-1- 5	Button Clamp Bracket	1	115151-0-00		b-1-2	Washer	2	146354-0-01	b-1 Snap Holder Assembly 115167-0-01
b-1-1- 6	Snap Clamp (Left)	1	118541-0-01		b-1-3	Bolt 4.76 x 14	2	017711-4-12	
b-1-1- 7	Snap Clamp (Middle)	1	118540-0-01		b-1-4	Hook	1	115146-0-01	
b-1-1- 8	Snap Clamp (Right)	1	118539-0-01		b-1-5	Screw 6.35	1	014770-6-22	
b-1-1- 9	Button Clamp Plate	1	115269-0-01		b-1-6	Button Clamp Holder	1	115143-2-01	
b-1-1-10	Screw 3.57 x 8	2	009670-8-12						

## DIFFERENT PARTS LIST

Ref. No.	Name of Parts	Sub-class	-1		-2		-3	
			Standard	with Eye Guard & Finger Guard	Standard	with Eye Guard & Finger Guard	Standard	with Eye Guard & Finger Guard
B-21		Worm	115062-0-01		118543-0-01		115062-0-01	
D-38		Transverse Feed Cam	115082-0-00		118542-0-00		153566-0-00	
D-40		Worm Wheel	115081-0-01		118544-0-01		115081-0-01	
F-32		Finger Guard	/	151051-0-01	/	151051-0-01	/	151051-0-01
F-33		Bolt	/	146360-0-02	/	146360-0-02	/	146360-0-02
Z-21		Eye Guard Assembly	/	143971-0-01	/	143971-0-01	/	143971-0-01



# I N D E X

Parts No.	Ref. No.	Remark	Parts No.	Ref. No.	Remark	Parts No.	Ref. No.	Remark	Parts No.	Ref. No.	Remark
001401-4-16	Z-12- 4		025060-1-32	E-16		115012-0-01	C-11-11		115101-0-01	F- 7	
001670-5-12	a- 1-21		025060-2-32	Z-15		115013-0-01	C-10		115102-0-01	D-14	
003670-6-12	B-49		025660-2-32	Z-21- 4		115014-0-01	C-11- 8		115103-0-01	D-20	
005660-7-13	Z-21- 1		025710-2-32	A-39		115015-1-01	C-11- 1		115104-0-01	D-19	
005681-0-12	B- 8		025710-2-33	D-55		115016-0-01	C-11- 6		115105-0-01	D-17	
009661-2-13	D-58		025800-3-33	C-11- 4		115017-0-01	C-11- 2		115106-0-01	D-21- 1	
009670-5-12	a- 1-12		047250-6-42	F-31- 8			Z-13		115108-0-01	D-22	
009670-7-12	a- 1- 9		048030-3-42	A-11		115018-0-01	C-11- 3		115109-0-01	D-48- 1	
009670-8-12	B- 3			F- 1- 3		115020-0-01	C-13		115112-0-01	D-48- 6	
	F-31-14		048030-3-46	E- 7		115021-0-01	C-12		115113-0-01	D-48- 2	
	a- 1-14		071079-4-50	C-14- 1		115022-0-01	A-43		115114-0-01	D-48- 5	
	b- 1- 1-10		100008-0-03	A-26		115025-0-01	A-41		115115-0-01	D-48- 4	
009680-6-12	D-18		100134-0-01	E-33		115026-0-01	A-42		115116-0-01	D-48- 3	
009680-7-13	A-47		100136-0-01	E-31		115027-1-01	C- 8		115117-0-00	D-49	
009689-4-12	F-31- 6			E-37		115041-0-01	B-17- 4		115118-0-01	D-50	
009710-6-12	B-47		100447-0-01	Z-19		115042-0-01	B-17- 5		115119-0-01	D-51	
009710-7-12	A-19		100546-0-01	E- 5		115046-0-01	B-12		115120-0-01	D-52	
	D-23		101028-0-00	B-20		115047-0-01	B-13		115121-1-01	D-53	
009710-7-13	E-11		101572-1-01	Z- 2		115048-0-01	B-11- 1		115123-0-01	Z- 8	
009711-0-12	A- 6		102571-0-03	A-44		115050-0-01	B- 2		115124-0-01	C-31	
	E- 1		102707-0-03	a- 1-15		115051-0-00	B- 1		115125-0-01	F-18	
	E- 8		104525-0-01	E-32		115052-0-00	B- 5		115126-0-01	F-15	
009711-2-12	A-38		105329-0-01	A-51		115053-0-16	B- 7		115127-0-01	F-16	
009711-2-13	E-28		105344-0-01	Z- 4		115054-1-01	B-46		115128-1-00	F- 9	
009751-6-12	F-10		105872-0-01	C- 6		115055-0-01	B-10		115130-0-01	F-12	
013710-5-10	F-17		106629-0-01	A-22		115057-0-01	B-33		115131-1-01	D-43	
013710-7-12	C-14- 4		107155-0-01	B-17- 7		115058-0-00	B-32		115132-0-01	F-11	
013711-0-10	C-27		107282-0-02	F-23		115059-0-00	B-24		115133-0-01	F-13	
	D-36		107407-0-03	F- 6		115060-0-01	B-27		115134-1-01	F- 8	
013719-4-12	F-43		107744-0-01	F- 1- 2		115061-0-01	C-30		115135-1-01	F- 3	
	a- 1- 7		107780-0-01	Z- 5		115062-0-01	B-21		115137-0-01	A-16	
013750-6-10	A-34		107793-0-00	C-40		115063-0-01	B-29		115138-0-01	A-17	
	B-40		109854-0-01	Z-18		115064-0-01	B-31		115139-0-01	F- 1- 1	
	C-36		110124-0-01	B-38		115065-0-00	B-37		115143-2-01	F-21	
013751-0-10	A-49		110161-0-04	C- 9		115066-0-00	B-39			b- 1- 6	
	F-14		110249-0-01	E-20		115067-0-01	B-41		115144-0-01	F-19	
013770-6-10	A-56		112300-0-01	A- 3		115068-0-01	B-43		115145-0-01	F-20	
014770-6-22	B-17- 9		112301-0-01	A- 1		115069-0-01	B-45		115146-0-01	F-27	
	B-19		114483-0-01	Z-10		115070-0-00	B-48			b- 1- 4	
	B-22		114973-0-01	B-18		115071-0-01	B-50		115147-0-01	F-25	
	B-28		114976-0-01	A-24		115072-0-01	B-51		115148-1-01	F-24	
	B-30		114977-0-01	A-25		115073-0-01	B-35		115149-0-01	F-22	
	C-29		114978-1-01	A-21		115076-0-01	B-36		115151-0-00	F-31- 5	
	C-32		114979-1-01	A-20		115077-0-01	B-34			b- 1- 1- 5	
	D-39		114980-0-01	D-35		115078-0-01	D-42		115156-0-01	F-31-16	
	D-41		114982-0-00	A-53		115079-0-00	D-47			b- 1- 1-12	
	D-44		114984-0-00	A-35		115080-0-00	D-37		115158-0-01	F-31-17	
	D-46		114985-0-01	A-48		115081-0-01	D-40			b- 1- 1-13	
	D-48- 1- 1		114986-0-01	A-23		115082-0-00	D-38		115160-0-01	A-55	
	F- 2		114988-0-01	A-52		115084-0-00	D-45		115161-0-01	F-31- 1	
	F-28		114989-0-01	C-34		115085-0-01	a- 2			b- 1- 1- 4	
	b- 1- 5		114990-0-01	C-14		115087-0-01	D- 4		115162-0-01	F-31-15	
014821-0-22	C-21		114991-0-01	C-14- 5		115088-0-01	D- 7			b- 1- 1-11	
015770-8-12	B-17- 8		114992-0-00	C-14- 6		115089-0-01	D- 8		115163-0-01	F-31-18	
017711-4-12	F-29		114993-0-00	C-14- 7		115090-0-01	D- 6			b- 1- 1-14	
	b- 1- 3		114994-0-01	C-14- 8		115091-0-01	D- 5		115164-0-01	F-31- 3	
017751-4-12	B-14		114995-0-01	C-14- 2		115092-0-01	D-10			b- 1- 1- 2	
017822-2-13	C- 7		114997-0-01	C-14- 3		115093-0-01	D-11		115165-0-01	F-31- 2	
021060-1-02	Z-17		114998-0-00	C-23		115094-0-01	D-16			b- 1- 1- 1	
021400-1-06	Z-12- 3		114999-0-01	C-15			D-34		115166-0-01	F-31- 4	
021660-1-02	D-57		115000-0-00	C-16		115095-0-01	D-33			b- 1- 1- 3	
	E-25		115002-0-01	C-18		115096-0-00	D-29		115167-0-01	b- 1	
021660-1-03	Z-21- 5		115003-0-01	C-19		115097-0-01	D-26		115171-0-01	E-41	
021670-1-03	A-27		115004-0-01	C-20			D-32		115172-0-01	E-42	
021710-1-03	D-15		115007-0-01	B-25		115098-0-01	D-27		115173-0-01	E-26	
021750-1-03	A-40			C-26			D-31		115174-0-01	E-27	
	B-15		115008-0-00	B-26		115099-0-01	D-24		115175-0-01	E-29	
	C-17			C-25			D-12		115176-0-01	E-30	
021800-1-03	B-17- 2		115010-0-01	C-11- 9		115100-0-01	D-12		115177-0-01	E-24	
	C-11- 5		115011-0-01	C-11-10		115101-0-01	D-13		115178-0-01	E-21	

Parts No.	Ref. No.	Remark	Parts No.	Ref. No.	Remark	Parts No.	Ref. No.	Remark	Parts No.	Ref. No.	Remark
115179-0-01	F-12		143964-0-01	Z-21- 2		182339-0-01	B-17- 6- 1				
115180-0-01	E- 9		143966-0-01	Z-21- 3		182350-0-01	B-11				
115183-1-01	A-18		143971-0-01	Z-21							
115184-0-01	A-15		144224-0-01	Z-22							
115186-0-01	E-40		144486-0-01	E-19							
115187-0-01	E-34		144509-0-00	C-35							
	E-39		144510-0-01	C-37							
115188-0-01	E-38		144513-0-01	D-61							
115189-0-01	A-14		144514-0-01	D-63							
115190-0-01	E-36		144515-0-01	D-60							
115191-0-01	F-35		144516-0-01	D-59							
115192-0-01	A-13		144517-0-01	D-62							
115204-0-01	E- 2		144518-0-01	C-39							
115212-1-01	A- 7		144519-0-01	C-38							
115214-1-00	C-28		144520-0-01	C- 3							
115215-0-00	C-33		144523-0-01	C- 1							
115268-0-01	A-37		144524-0-00	C- 2							
	A-46		144525-0-01	C- 5							
115269-0-01	F-31-13		144526-0-01	C- 4							
	b- 1- 1- 9		144543-0-01	Z-14							
115270-0-01	A-54		144657-0-00	B-16							
115275-0-01	A-50		144659-1-01	D- 1							
115947-0-01	Z-16		144669-0-01	E-17							
116016-0-01	Z-12- 2		144670-0-01	E-18							
116185-2-01	Z-12		144671-0-01	E-15							
116323-0-01	A- 4		144672-0-01	E- 6							
117291-0-01	D- 9		144673-0-01	E- 3							
117363-0-02	D-56		144674-0-00	E- 4							
	E-14		144700-1-01	B-17							
	E-23		144701-0-00	B-17- 3							
117437-1-01	Z-12- 1		144711-0-01	B- 9							
117685-0-01	D-25		144747-2-01	C-11							
117873-1-01	F- 4		145277-1-03	Z- 9							
117879-0-01	A- 9		146354-0-01	D- 3							
118538-0-01	b- 1- 1			E-10							
118539-0-01	b- 1- 1- 8			E-13							
118540-0-01	b- 1- 1- 7			E-22							
118541-0-01	b- 1- 1- 6			F- 5							
118542-0-00	D-38			F-30							
118543-0-01	B-21			b- 1- 2							
118544-0-01	D-40			146360-0-02	D- 2						
118837-0-01	Z- 3				F-33						
120990-0-01	a- 1- 3			146994-0-01	F-26						
	a- 1- 4		147114-0-01	D-54							
122991-0-01	Z- 1		148425-0-01	B-17- 1-2-1							
140553-1-01	B- 6		149995-0-01	C-24							
142205-0-01	Z- 6		149996-0-01	C-22							
142307-0-01	A-36		150397-1-01	F-31- 9							
142308-0-01	F- 1		150398-0-01	F-31- 7							
142360-0-01	A- 5		150399-1-01	F-31-12							
142361-0-00	A- 2		150401-0-01	F-31-11							
142570-0-01	a- 1		150402-0-01	F-31-10							
142656-0-01	Z-20		150403-1-01	F-31							
142658-0-01	B-17- 6-1-2		150554-0-01	C-11-12							
142672-0-01	A-10		151051-0-01	F-32							
142676-0-01	a- 1-13		151601-0-01	B-42							
142677-0-01	a- 1-16		151602-0-01	B-44							
142678-0-01	a- 1-17		151604-0-01	C-41							
142679-0-01	a- 1- 6		151605-0-02	D-30							
142680-0-01	a- 1- 5		151881-0-01	A- 8							
142681-0-01	a- 1- 8		153566-0-00	D-38							
142682-0-01	a- 1-11		153808-0-01	B- 4							
142683-0-01	a- 1- 2		154224-0-01	A-31							
142684-0-01	a- 1- 1		154225-0-01	A-30							
142685-0-01	a- 1-22		180910-0-01	D-21							
142686-0-01	a- 1-20		180982-0-01	D-48							
142687-0-01	a- 1-19		181236-0-01	Z-11							
142688-0-01	a- 1-18		181312-0-01	B-17- 6							
142706-0-01	a- 1-10		181313-0-01	B-17- 1							
142721-0-01	Z- 7		181314-0-01	B-17- 1- 2							

[www.PromElectroAvtomat.ru](http://www.PromElectroAvtomat.ru)

• 118-913  
195913-3-02  
1983, 1