

# DB2-B101 DB2-B755MKIII-3A

パーツブック  
PARTS BOOK  
TEILEKATALOG  
LIVRE DES PIECES  
LIBRO DE REFERENCIA DE PIEZAS

直線本縫ミシン

SINGLE-NEEDLE STRAIGHT LOCK STITCHER

EINNADEL-STEPSTICH-SCHNELLNÄHER

PIQUEUSE POINT NOUE - 1 AIGUILLE

PUNTADA RECTA 1 AGUJA

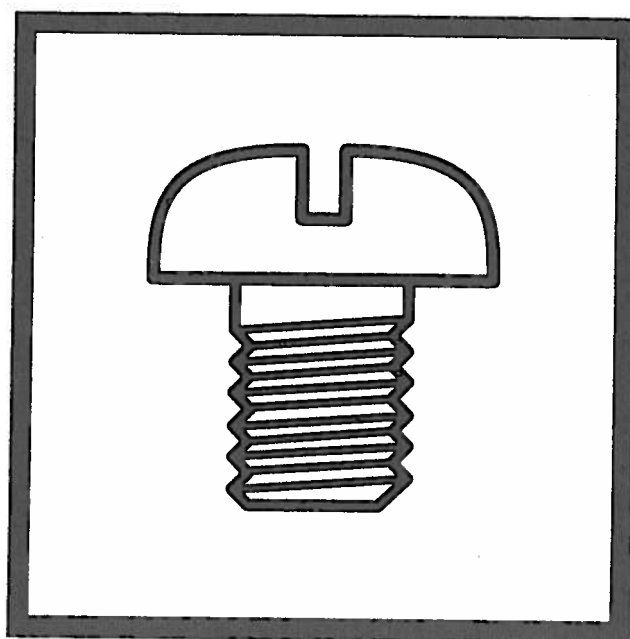

---

brother.

100-100000  
100-100000  
100-100000  
100-100000  
100-100000

RECEIVED  
DEPARTMENT OF  
INTERNAL SECURITY

ALL INFORMATION CONTAINED HEREIN IS UNCLASSIFIED

DATE 10/15/2003 BY SP8 BTJ/STW

EXCEPT WHERE SHOWN OTHERWISE

ALL INFORMATION CONTAINED

HEREIN IS UNCLASSIFIED

DATE 10/15/2003 BY SP8 BTJ/STW

EXCEPT WHERE SHOWN OTHERWISE

ALL INFORMATION CONTAINED

HEREIN IS UNCLASSIFIED

DATE 10/15/2003 BY SP8 BTJ/STW

EXCEPT WHERE SHOWN OTHERWISE

ALL INFORMATION CONTAINED

HEREIN IS UNCLASSIFIED

DATE 10/15/2003 BY SP8 BTJ/STW

EXCEPT WHERE SHOWN OTHERWISE

ALL INFORMATION CONTAINED

HEREIN IS UNCLASSIFIED

DATE 10/15/2003 BY SP8 BTJ/STW

EXCEPT WHERE SHOWN OTHERWISE

ALL INFORMATION CONTAINED

HEREIN IS UNCLASSIFIED

DATE 10/15/2003 BY SP8 BTJ/STW

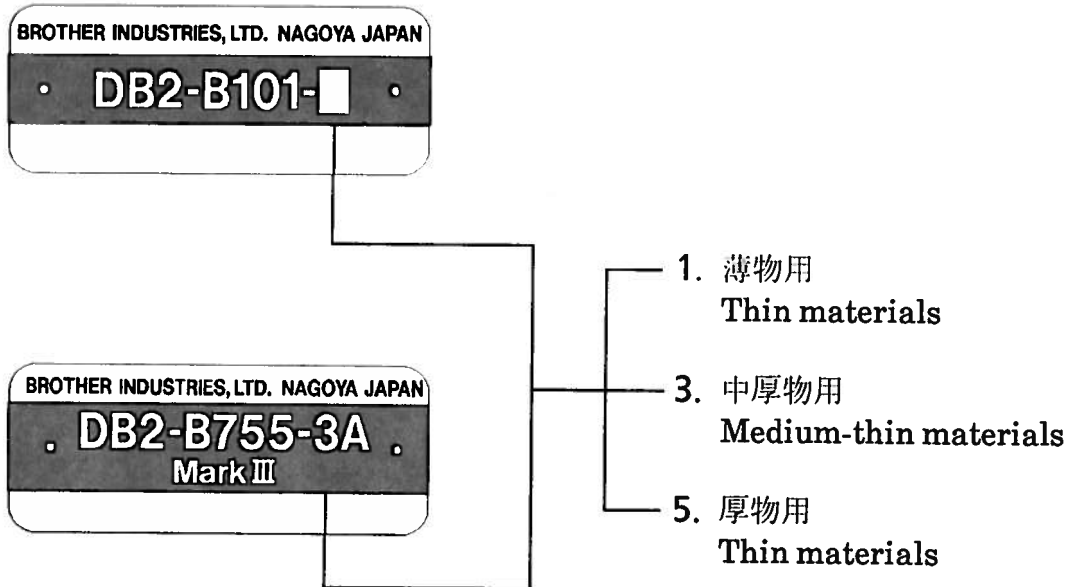

### パーツブックご利用に際して

1. この本は、1996年4月のデータに基づいて作成されたものです。
2. 部品は予告なしに設計変更される場合があります。
3. 組単位で補給する部品は、[ ]破線で示しております。
4. 部品コード欄が※となっている場合は、仕様別部品一覧表(23ページ)でお調べ下さい。

### 目 次

A. 主体関係 .....	1
B. 膝上ゲ関係 .....	1
C. 針棒・天秤関係 .....	3
D. 押工関係 .....	7
E. 送り関係 .....	9
F. カマ関係 .....	13
G. 給油潤滑関係 .....	15
H. 糸通シ関係 .....	17
Z. 付属品関係 .....	19
Sp. 仕様別部品一覧表 .....	23
Wa. 警告ラベル .....	24
索引 .....	24

# Notes for using this parts book

1. This book was prepared based on information available in April 1996.
2. Parts are subject to changes in design without prior notice.
3. Parts supplied as complete assemblies are circled by a dotted line [ ] .
4. If the symbol ※ is found in the "Parts No." column, refer to the different parts list on page 23.

## CONTENTS

A. Machine body .....	1
B. Knee lifter mechanism .....	1
C. Needle bar and thread take-up mechanism .....	3
D. Presser foot mechanism .....	7
E. Feed mechanism .....	9
F. Rotary hook mechanism .....	13
G. Lubrication .....	15
H. Threading mechanism .....	17
Z. Accessories .....	19
Sp. Different parts list .....	23
Wa. Warning labels .....	24
INDEX .....	24

## Hinweise zur Verwendung dieser Teileliste

1. Dieses Buch basiert auf den Informationen vom April 1996.
2. Modelländerungen sind vorbehalten.
3. Die Teile, die als kompletter Satz geliefert werden, sind mit einer [ ] gestrichelte Linie umrandet.
4. Dieses Zeichen ※ in der Spalte "Parts No. (Teil-nummer)" verweist auf die Gesonderte Stückliste auf Seite 23.

## INHALTSVERZEICHNIS

A. Maschinengehäuse .....	1
B. Kniehebel .....	1
C. Nadelstange und Fadenabnahmevorrichtung .....	3
D. Stoffdrückerfuß .....	7
E. Transportvorrichtung .....	9
F. Greifervorrichtung .....	13
G. Schmierung .....	15
H. Fadenführungsvorrichtung .....	17
Z. Zubehör .....	19
Sp. Zubeholiste .....	23
Wa. Warnschilder .....	24
VERZEICHNIS .....	24

# Notes sur l'utilisation de ce manuel de pièces détachées

1. Ce manuel a été fait d'après les renseignements valables au mois de Avril 1996.
2. Les pièces peuvent être sujettes à des modifications sans préavis.
3. Les pièces fournies en tant qu'assemblages complets sont encadrées avec un trait pointillé [ ] .
4. Si le symbole ※ se trouve dans la colonne "Parts No. (No de pièce)" veuillez la vous référer à la liste de pièces annexe page 23.

## TABLE DES MATIERES

A. Corps de la machine .....	1
B. Mécanisme de genouillère .....	1
C. Mécanisme de la barre à aiguille et releveur de fil ...	3
D. Mécanisme de pied presseur .....	7
E. Mécanisme de l'entraînement .....	9
F. Mécanisme du crochet rotatif .....	13
G. Lubrification .....	15
H. Mécanisme de l'enfilage .....	17
Z. Accessoires .....	19
Sp. Liste des pieces accessoires .....	23
Wa. Etiquettes d'avertissement .....	24
INDEX .....	24

## Notas para usar este Manual de Piezas

1. Este libro ha sido compilado basándose en los datos de que se disponía en marzo 1996.
2. Las piezas quedan sujetas a cambios de diseño sin aviso previo.
3. Las piezas suministradas como conjuntos completos se enmarcan con una línea punteada [ ] .
4. De haber un símbolo ※ junto al "Parts No. (Número de Pieza)", habrá que mirar la lista de piezas separada de la página 23.

## INDICE

A. Cuerpo de la máquina .....	1
B. Mecanismo de levantador de rodilla .....	1
C. Mecanismo de la barra de aguja y tirahilos .....	3
D. Mecanismo de la prensa tela .....	7
E. Mecanismo de la alimentación .....	9
F. Mecanismo del cangrejo .....	13
G. Lubricación .....	15
H. Mecanismo del enhebrado .....	17
Z. Accesorios .....	19
Sp. Lista de piezas accessorias .....	23
Wa. Etiquetas de advertencia .....	24
INDICE .....	24

A . 主体関係 / Machine body / Maschinengehäuse / Corps de la machine / Cuerpo de la máquina

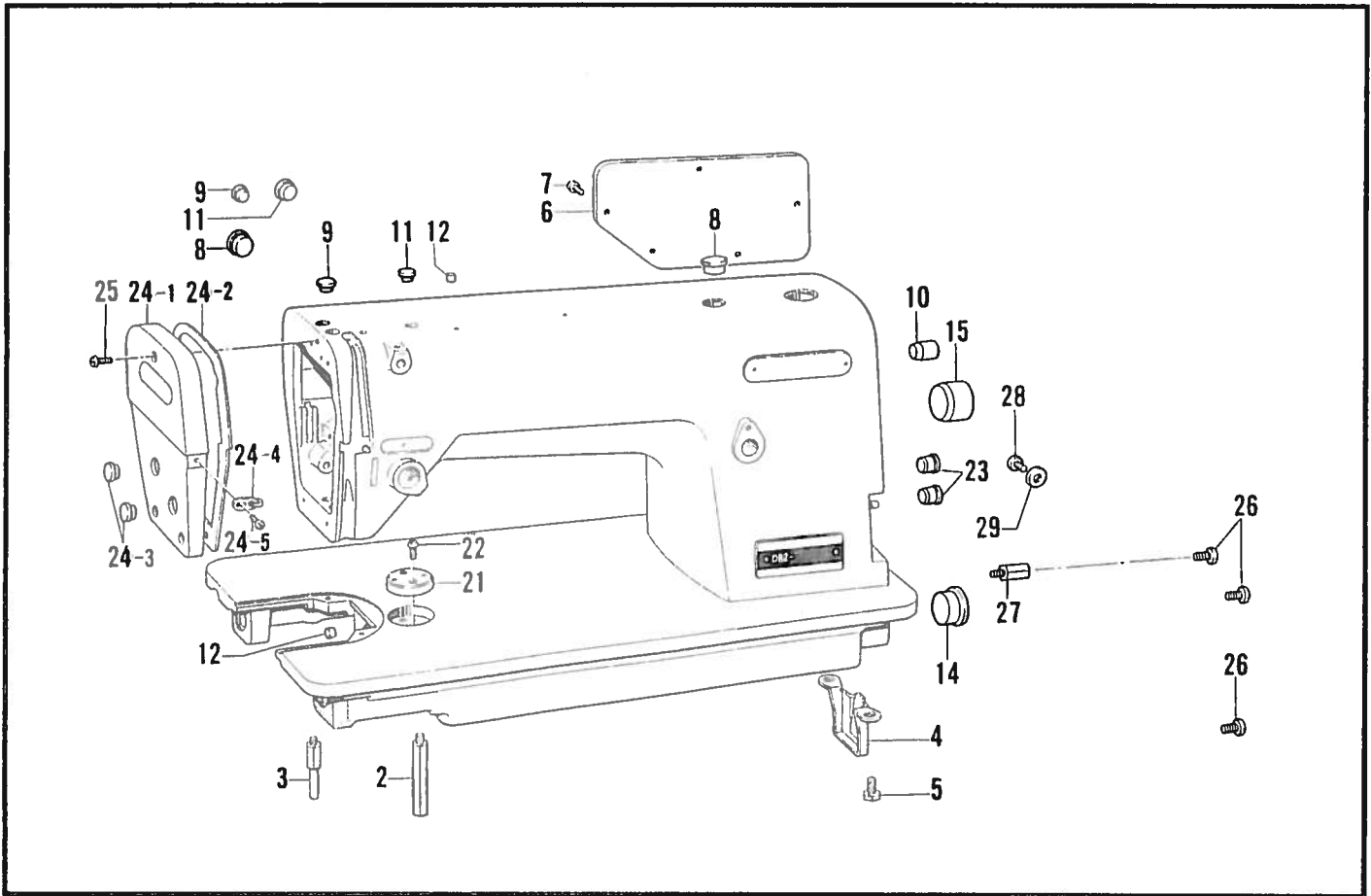

877-101-050

B . 膝上げ関係 / Knee lifter mechanism / Kniehebel / Mécanisme de genouillère / Mecanismo de levantador de rodilla

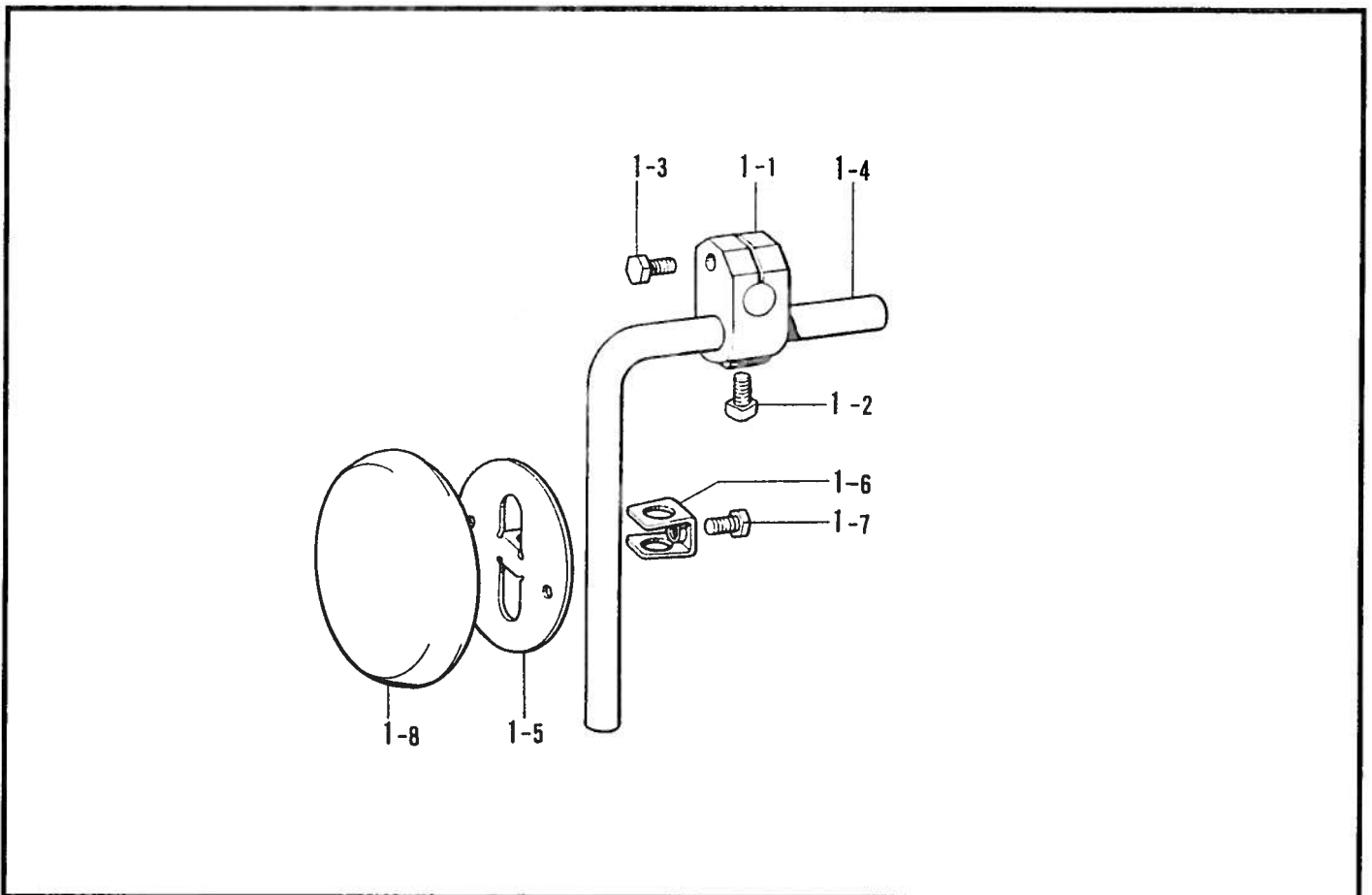

877-101-203

A. 主体関係 / Machine body / Maschinengehäuse / Corps de la machine / Cuerpo de la máquina

REF.NO.	CODE	Q'TY	ヒンメイ	NAME OF PARTS	RM
2	104829121	1	キヤクチュウL	BED LEG (L)	
3	104830121	1	キヤクチュウS	BEL LEG (S)	
4	118672021	1	ポンプカバー	PUMP COVER	
5	140704021	2	ボルト7.14	BOLT, SM7.14	
6	S35530021	1	ガワイタ	REAR COVER	
7	062681012	5	ナベコ437-40X10	SCREW, PAN SM4.37-40X10	
8	104449009	2	ゴムセン15.5	RUBBER CAP, 15.5	
9	104450109	2	ゴムセン8	RUBBER CAP, 8	
10	104832009	1	ゴムセン10.7	RUBBER CAP, 10.7	
11	104821009	2	ゴムセン10.5	RUBBER CAP, 10.5	
12	142274009	2	ゴムセン4.2	RUBBER CAP, 4.2	
14	108520009	1	ゴムセン19.8	RUBBER CAP, 19.8	
15	104451009	1	ゴムセン23.9	RUBBER CAP, 23.9	
21	S09621001	1	ジヨウギイタ	RULER PLATE	
22	062670612	1	ナベコ357-40X6	SCREW, PAN SM3.57-40X6	
23	104450109	2	ゴムセン8	RUBBER CAP, 8	
24	S35525021	1	メンイタクミ	FACE PLATE ASSY	
24-1	S35526021	1	メンイタ	FACE PLATE	
24-2	S35529020	1	メンイタバツキン	FACE PLATE PACKING	
24-3	104449009	2	ゴムセン15.5	RUBBER CAP, 15.5	
24-4	S02617001	1	メンイタイトアンナイ	FACE PLATE THREAD GUIDE	
24-5	060670612	1	バインド357-40X6	SCREW, BIND SM3.57-40X6	
25	062671012	3	ナベコ357-40X10	SCREW, PAN SM3.57-40X10	
26	062760812	3	<For "Full cover type"> ナベコ595-28X8	SCREW, PAN SM5.95-28X8	
27	157969021	1	スタッド	STUD	
28	062680812	1	ナベコ437-40X8	SCREW, PAN SM4.37-40X8	
29	100645023	1	ザガネ	WASHER	

877-101-050

B. 膝上ゲ関係 / Knee lifter mechanism / Kniehebel / Mécanisme de genouillère / Mecanismo de levantador de rodilla

REF.NO.	CODE	Q'TY	ヒンメイ	NAME OF PARTS	RM
1	S35821021	1	ヒザアテクミ	KNEE LIFTER ASSY	
1-1	146039021	1	ヒザアテツギテ	KNEE LIFTER JOINT	
1-2	100463021	1	4カクボルト7.94	BOLT, SM7.94	
1-3	S35820021	1	ボルト5.95X20	BOLT, SM5.95X20	
1-4	104619022	1	ヒザアゲタテジク	KNEE LIFTER BAR	
1-5	S34756021	1	ヒザアテ	KNEE LIFTER PLATE	
1-6	114967021	1	ヒザアテストツバ	KNEE LIFTER PLATE STOPPER	
1-7	110087021	1	ボルト5.95	BOLT, SM5.95	
1-8	S31885001	1	ヒザアテカバー	KNEE LIFTER PLATE COVER	

877-101-203

C. 針棒・天秤關係 / Needle bar and thread take-up mechanism  
 / Nadelstange und Fadenabnahmevorrichtung  
 / Mécanisme de la barre à aiguille et releveur de fil  
 / Mecanismo de la barra de aguja y tirahilos

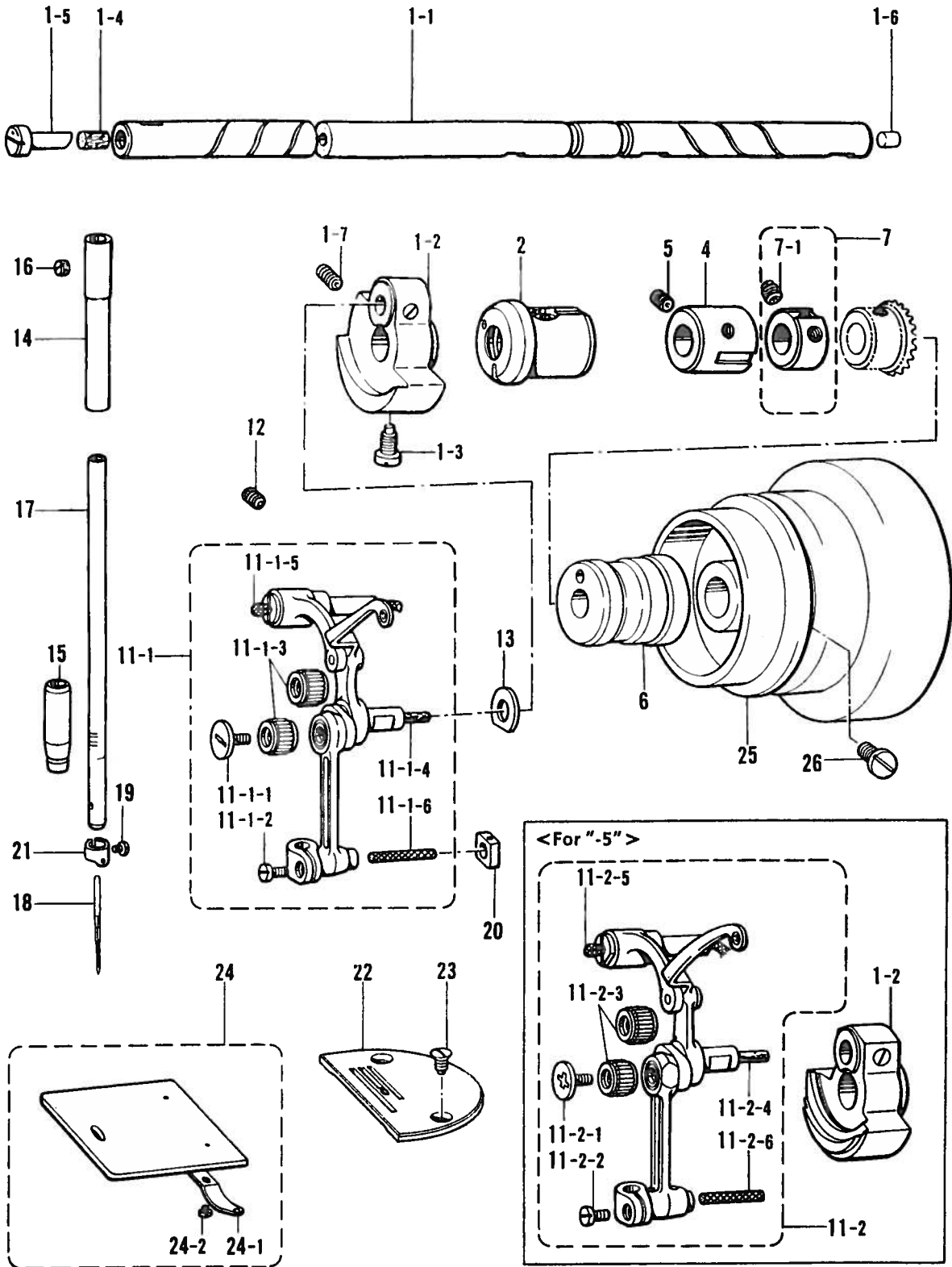



C. 針棒・天秤関係 / Needle bar and thread take-up mechanism

/ Nadelstange und Fadenabnahmevorrichtung

/ Mécanisme de la barre à aiguille et releveur de fil

/ Mecanismo de la barra de aguja y tirahilos

REF.NO.	CODE	Q'TY	ヒンメイ	NAME OF PARTS	RM
2	S37815021	1	ウワジクメタルL	UPPER SHAFT BUSH (L)	
4	140726020	1	ウワジクメタルM	UPPER SHAFT BUSH (M)	
5	013760610	1	トメネジ5.95クボミ	SET SCREW, (CP) SM5.95	
6	146331021	1	ウワジクメタルR	UPPER SHAFT BUSH (R)	
7	181916121	1	セツトカラークミ	SET SCREW COLLAR ASSY	
7-1	100251001	2	トメネジ6.35	SET SCREW, SM6.35	
12	013781012	1	トメネジ6.35クボミ	SET SCREW, (CP) SM6.35	
13	110367001	1	ザガネ	WASHER, PLAIN SPECIAL 8	
14	117242021	1	ハリボウメタルU	NEEDLE BAR BUSH (U)	
16	100260001	1	トメネジ5.95	SET SCREW, SM5.95	
19	140553102	1	アタマツキトメネジ3.18	SET SCREW, SM3.18	
20	102630021	1	ハリボウアンナイカクコマ	NEEDLE BAR GUIDE SLIDE BLOCK	
23	100032004	2	サラネジ4.37	SCREW, FLAT SM4.37	
24	180018121	1	スベリイタクミ	SLIDE PLATE ASSY	
24-1	114561021	1	スベリイタウラバネ	SPRING	
24-2	122771002	2	シメネジ2.38	SCREW, SM2.38	
26	S33689002	2	アタマトメクボミ595-14	SET SCREW, (CP) SM5.95-14	
-----					
1	S37812021	1	<For "-1,-3"> ウワジククミ	UPPER SHAFT ASSY	
1-1	S37814021	1	ウワジク	UPPER SHAFT	
1-2	S06325021	1	テンピン克蘭ククミ	THREAD TAKE-UP CRANK ASSY	
1-3	104464001	1	シメネジ7.14	SCREW, SM7.14	
1-4	146327001	1	フェルト7X10	FELT 7X10	
1-5	146333001	1	オイルチヨウセツベン	OIL REGULATE VALVE	
1-6	156641001	1	ゴムセン7.4	RUBBER CAP, 7.4	
1-7	014771022	1	アナトメネジ6.35クボミ	SET SCREW, SOCKET (CP) SM6.35	
11-1	S34287021	1	ハリボウレンカンクミ	THREAD TAKE-UP LEVER ASSY	
11-1-1	145465001	1	シメネジ3.57L	SCREW, SM3.57L	
11-1-2	140004001	1	シメネジ3.57	SCREW, SM3.57	
11-1-3	147777000	2	ニードルベアリング	NEEDLE BEARING	
11-1-4	145624000	1	フェルト	FELT	
11-1-5	155488000	1	クミヒモ	WICK (L = 90)	
11-1-6	158727001	1	クミヒモ4X4	WICK 4X4 (L = 27)	
15	S35817021	1	ハリボウメタルD	NEEDLE BAR BUSH (D)	
21	S14814001	1	ハリボウイトアンナイ	NEEDLE BAR THREAD GUIDE	
-----					
17	S14811021	1	<For "-1,-3"> ハリボウDB	NEEDLE BAR (DB)	
18	100265031	1	<For "-1"> ミシンハリDBX1	NEEDLE DBX1 (#11)	
22	S03884321	1	ハリイタE16	NEEDLE PLATE (E16)	
18	100265034	1	<For "-3"> ミシンハリDBX1	NEEDLE DBX1 (#14)	
17	S14815021	1	<For "-3TR,-3A"> ハリボウDP	NEEDLE BAR (DP)	
18	107415014	1	ミシンハリDPX5	NEEDLE DPX5 (#14)	
22	111859321	1	<For "-3,-3A"> ハリイタE18	NEEDLE PLATE (E18)	
22	100266021	1	<For "-3TR"> ハリイタB18	NEEDLE PLATE (B18)	
-----					
25	145471029	1	<For "Full cover type"> プーリー	PULLEY	
25	115244029	1	<For "Half cover type"> プーリー	PULLEY	

C. 針棒・天秤關係 / Needle bar and thread take-up mechanism  
 / Nadelstange und Fadenabnahmevorrichtung  
 / Mécanisme de la barre à aiguille et releveur de fil  
 / Mecanismo de la barra de aguja y tirahilos

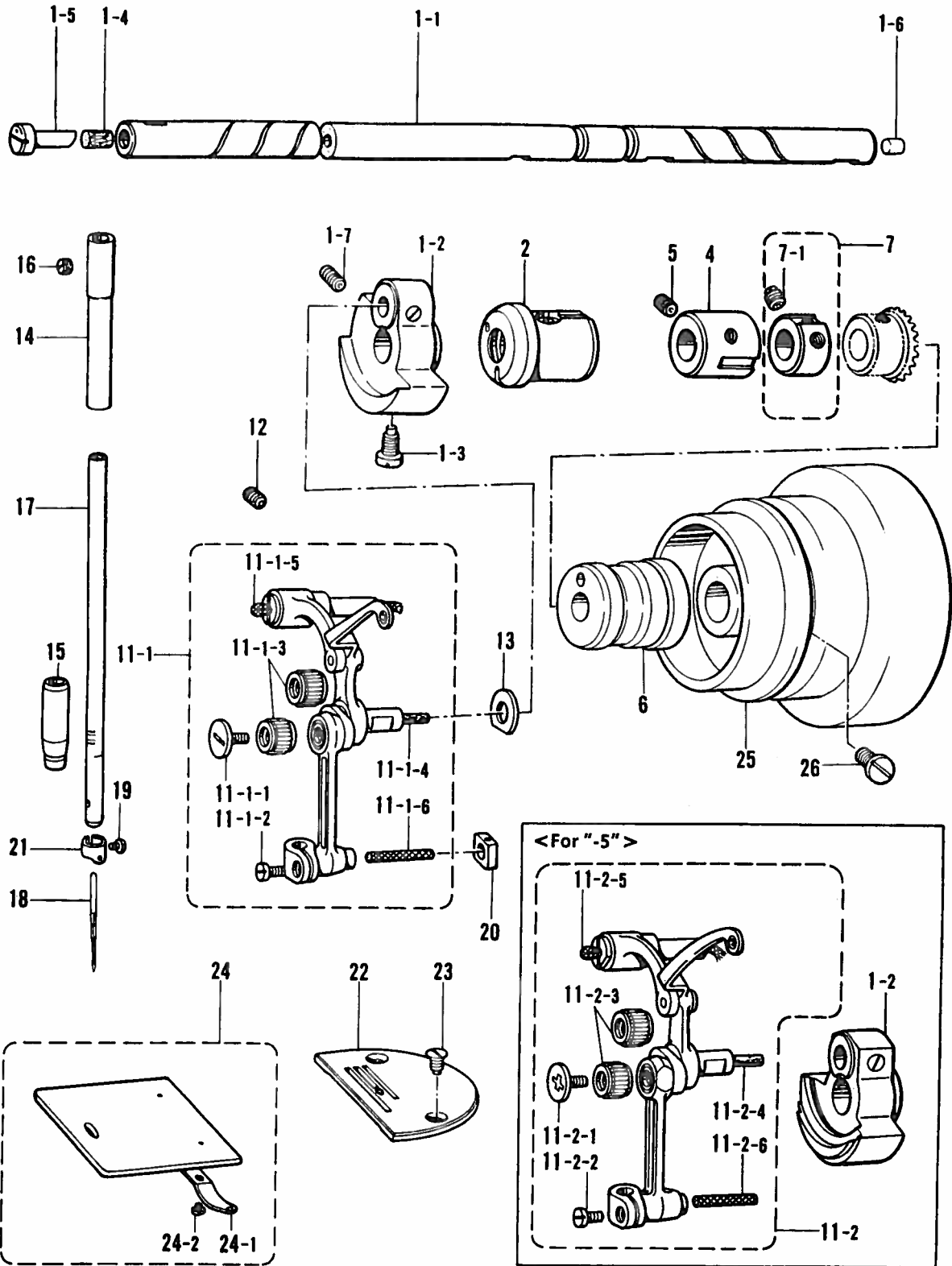

C. 針棒・天秤関係 / Needle bar and thread take-up mechanism

/ Nadelstange und Fadenabnahmevorrichtung

/ Mécanisme de la barre à aiguille et releveur de fil

/ Mecanismo de la barra de aguja y tirahilos

REF.NO.	CODE	Q'TY	ヒンメイ	NAME OF PARTS	RM
			<For "-5">		
1	S37813021	1	ウワジククミ	UPPER SHAFT ASSY	
1-1	S37814021	1	ウワジク	UPPER SHAFT	
1-2	S00909021	1	テンピンクラッククミ	THREAD TAKE-UP CRANK ASSY	
1-3	104464001	1	シメネジ7.14	SCREW, SM7.14	
1-4	146327001	1	フェルト7X10	FELT 7X10	
1-5	146333001	1	オイルチヨウセツベン	OIL REGULATE VALVE	
1-6	156641001	1	ゴムセン7.4	RUBBER CAP, 7.4	
1-7	100251001	2	トメネジ6.35	SET SCREW, SM6.35	
11-2	S34290021	1	ハリボウレンカククミ	NEEDLE TAKE-UP LEVER ASSY	
11-2-1	S13163001	1	シメネジ3.5L	SCREW, SM3.5 (L)	
11-2-2	140004001	1	シメネジ3.57	SCREW, SM3.57	
11-2-3	147777000	2	ニードルベアリング	NEEDLE BEARING	
11-2-4	145624000	1	フェルト	FELT	
11-2-5	155488000	1	クミヒモ	WICK (L = 90)	
11-2-6	158727001	1	クミヒモ4X4	WICK 4X4 (L = 27)	
15	147326021	1	ハリボウメタルD	NEEDLE BAR BUSH (D)	
17	S02811021	1	ハリボウ	NEEDLE BAR	
18	100265042	1	ミシンハリDBX1	NEEDLE DBX1 (#22)	
21	151594001	1	ハリボウイトアンナイ	NEEDLE BAR THREAD GUIDE	
22	150792021	1	ハリイタH26	NEEDLE PLATE (H26)	
			" OPTIN PARTS "		
18	100265036	1	ミシンハリDBX1	NEEDLE DBX1 (#16)	
18	100265039	1	ミシンハリDBX1	NEEDLE DBX1 (#19)	
18	107415011	1	ミシンハリDPX5	NEEDLE DPX5 (#11)	
18	107415022	1	ミシンハリDPX5	NEEDLE DPX5 (#22)	

D. 押工関係 / Presser foot mechanism / Stoffdrückerfuß / Mécanisme de pied presseur / Mecanismo de la prensa tela

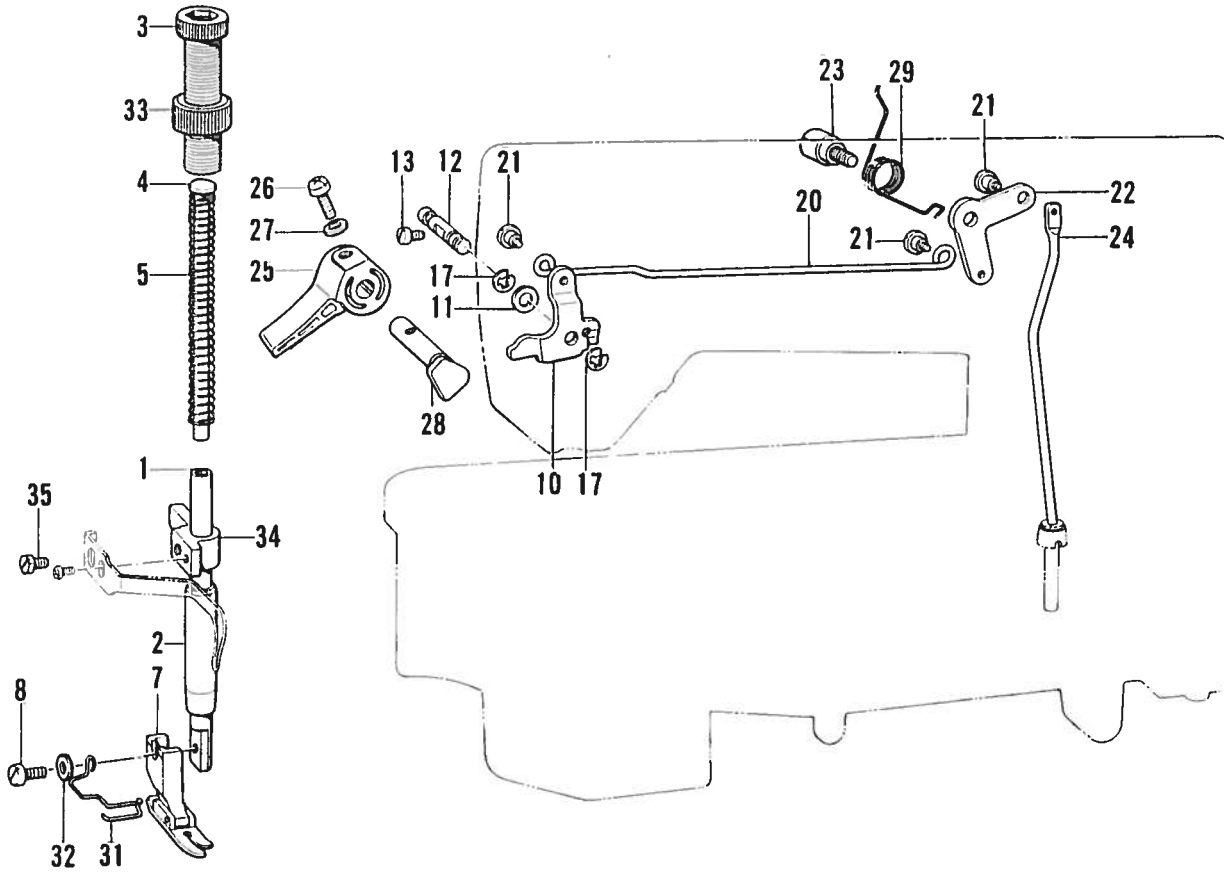

D. 押工関係 / Presser foot mechanism / Stoffdrückerfuß / Mécanisme de pied presseur / Mecanismo de la prensa tela

REF.NO.	CODE	Q'TY	ヒンメイ	NAME OF PARTS	RM
1	111466121	1	オサエボウ	PRESSER BAR	
2	145472021	1	オサエボウメタル	PRESSER BAR BUSH	
3	S31012001	1	オサエチヨウセツネジ	PRESSER ADJUST SCREW	
4	141208021	1	オサエバネアンナイ	SPRING GUIDE	
8	S13385001	1	シメネジ3.57X10	SCREW, SM3.57X10	
10	S01020022	1	オサエアゲレバー	PRESSER BAR LIFTER	
11	109763022	1	ザガネ	WASHER	
12	159998021	1	オサエアゲレバーク	PRESSER BAR LIFTER SHAFT	
13	S01998001	1	アタマツキトメネジ3.57	SET SCREW, SM3.57	
17	048040342	2	トメワE4	RETAINING RING, E4	
20	145476021	1	ヒザアゲレンカン	KNEE LIFTER CONNECTING ROD	
21	145478022	3	ダンネジ4.76	SHOULDER SCREW, SM4.76	
22	145479022	1	ヒザアゲレバー	KNEE LIFTER LEVER	
23	S31010021	1	ダンジク6.35	SHOULDER SCREW, SM6.35	
24	145481021	1	ヒザアゲボウ	KNEE LIFTER BAR	
25	S31006001	1	オサエアゲテコ	PRESSER BAR LIFTER	
26	062351216	1	ナベコ35X12	SCREW, PAN M3.5X12	
27	102707021	1	ザガネ	WASHER	
28	S31952021	1	オサエアゲクランク	PRESSER BAR LIFTER CRANK	
29	154347001	1	ヒザアゲレバーバネ	SPRING	
33	S31013001	1	チヨウセツネジツマミナツト	PRESSER ADJUST NUT	
34	S00879021	1	オサエボウダキ	PRESSER BAR GUIDE BRACKET	
35	142403001	1	ボルト5.95	BOLT, SM5.95	
5	147514001	1	<For "-1"> オサエバネ	PRESSER SPRING	
7	153037221	1	オサエクミ	PRESSER FOOT ASSY	
5	141728001	1	<For "-3,-5"> オサエバネ	PRESSER SPRING	
7	113280121	1	<For "-3,-3TR"> オサエクミ	PRESSER FOOT ASSY	
7	S36905021	1	<For "-3A"> オサエクミ	PRESSER FOOT ASSY, W/F.GUARD	
7	150789121	1	<For "-5"> オサエクミ	PRESSER FOOT ASSY	
31	150384121	1	" OPTION PARTS " フィンガーガード	FINGER GUARD	
32	S28919021	1	ヒラザガネシヨウ	WASHER, PLAIN S	

E. 送り関係 / Feed mechanism / Transportvorrichtung / Mécanisme de l'entraînement / Mecanismo de la alimentación

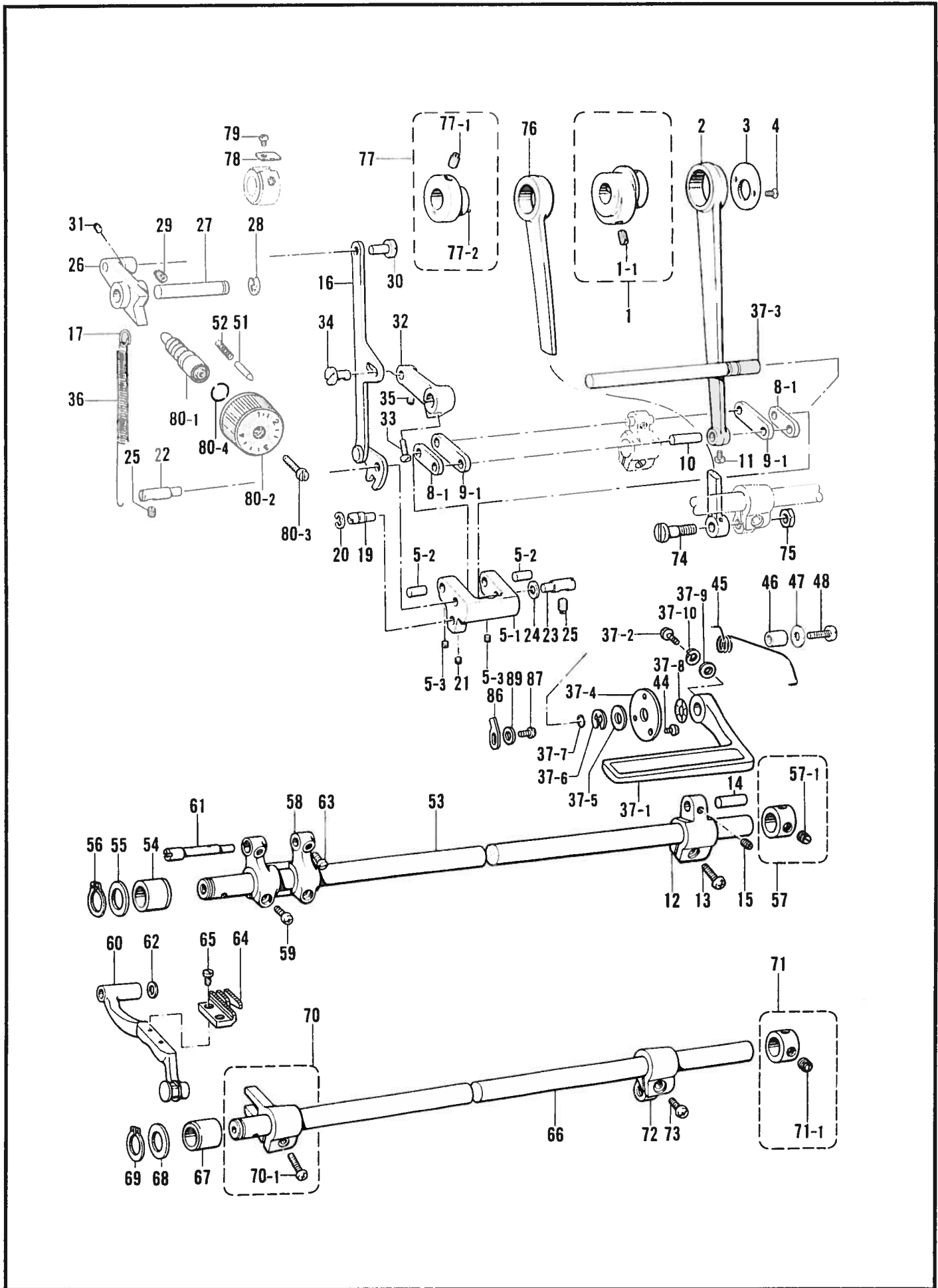

E. 送り関係 / Feed mechanism / Transportvorrichtung / Mécanisme de l'entraînement / Mecanismo de la alimentación

REF.NO.	CODE	Q'TY	ヒンメイ	NAME OF PARTS	RM
1-1	013761410	2	トメネジ5.95クボミ	SET SCREW, (CP) SM5.95	
2	156949021	1	スイハイオクリレンカン	LEVEL FEED CONNECTING ROD	
3	156948021	1	レンカンオサエ	CONNECTING ROD PRESSER	
4	108960002	2	サラネジ3.57	SCREW, FLAT SM3.57	
5	S05898021	1	キリカエキクミ	LEVEL REGULATOR ASSY	
5-1	156950120	1	キリカエキ	LEVEL REGULATOR	
5-2	156951021	2	オクリリンクジク	FEED LINK STUD	
5-3	014680622	2	アナトメネジ4.37クボミ	SET SCREW, SOCKET (CP) SM4.37	
8	156952021	1	スイハイオクリリンククミ	FEED ROCK LINK ASSY	
8-1	156953021	2	スイハイオクリリンク	FEED ROCK LINK	
9	156954021	1	スイハイオクリウデリンククミ	FEED ROCK ARM LINK ASSY	
9-1	156955021	2	スイハイオクリウデリンク	FEED ROCK ARM LINK	
10	156956021	1	リンクジク	LINK SHAFT	
11	144458001	1	アタマツキトメネジ3.57	SET SCREW, SM3.57	
12	156957020	1	スイハイオクリウデ	FEED ROCK ARM	
13	062711412	1	ナベコ4.76-32X14	SCREW, PAN SM4.76-32X14	
14	156958021	1	スイハイオクリウデジク	FEED ROCK ARM STUD	
15	151601002	1	トメネジ4.37	SET SCREW, M4.37	
16	158021122	1	キリカエキレンカンクミ	FEED REGULATOR CONNECTING ROD ASSY	
17	S04228001	1	バネカケ	SPRING HOOK	
19	156966121	1	ヘンシンピン	PIN	
20	048060342	1	トメワE6	RETAINING RING, E6	
21	014680622	1	アナトメネジ4.37クボミ	SET SCREW, SOCKET (CP) SM4.37	
22	156967021	1	キリカエジクL	FEED REGULATOR SHAFT (L)	
23	118734021	1	キリカエキジク	FEED REGULATOR SHAFT	
24	118735021	1	ザガネ	WASHER	
25	151604001	2	トメネジ5.95	SET SCREW, SM5.95	
26	156969021	1	オクリチヨウセツキ	FEED REGULATOR	
27	156970021	1	オクリチヨウセツキジク	FEED REGULATOR SHAFT	
28	048070342	1	トメワE7	RETAINING RING, E7	
29	014761030	1	アナクボミ595-28X10	SET SCREW, SOCKET (CP) SM5.95	
30	151308121	1	レンカンジク12.5	CONNECTING STUD 12.5	
31	014680422	1	アナトメネジ4.37クボミ	SET SCREW, SOCKET (CP) SM4.37	
32	156971020	1	レバー	LEVER	
33	062711412	1	ナベコ4.76-32X14	SCREW, PAN SM4.76-32X14	
34	151308121	1	レンカンジク12.5	CONNECTING STUD 12.5	
35	014680422	1	アナトメネジ4.37クボミ	SET SCREW, SOCKET (CP) SM4.37	
37	S35543121	1	カエシヌイレバージククミ	REVERSE STITCHING LEVER SHAFT	
37-1	S32921120	1	カエシヌイレバー	REVERSE LEVER	
37-2	S37333001	1	ナベコ4.76-32X14	SCREW, PAN SM4.76-32X14	
37-3	S32922021	1	カエシヌイレバージク	REVERSE STITCHING LEVER SHAFT	
37-4	147504021	1	カンザ	WASHER	
37-5	S35818021	1	ヒラザガネシヨウ10	WASHER, PLAIN S10	
37-6	048080342	1	トメワE8	RETAINING RING, E8	
37-7	104564001	1	リング	O RING	
37-8	213765021	1	ナミワ02X10.5X20	WAVE RING, 02X10.5X20	
37-9	153484021	1	ザガネ4.76	WASHER, PLAIN 4.76	
37-10	S35830021	1	バネザガネ2-5	WASHER, SPRING 2-5	
44	062670712	3	ナベコ357-40X7	SCREW, PAN SM3.57-40X7	
46	151317021	1	カラー	COLLAR	
47	S35819021	1	ヒラザガネダイ6	WASHER, PLAIN L6	
48	062782512	1	ナベコ635-28X25	SCREW, PAN SM6.35-28X25	
51	145502021	1	メモリイチギメピン	POSITIONING PIN	
1	S02552021	1	<For "-1,-3"> スイハイヘンシンリンネジツキ	LEVEL FEED ECCENTRIC WHEEL	
1	156946021	1	<For "-3TR,-5"> スイハイヘンシンリンネジツキ	LEVEL FEED ECCENTRIC WHEEL	

E. 送り関係 / Feed mechanism / Transportvorrichtung / Mécanisme de l'entraînement / Mecanismo de la alimentación

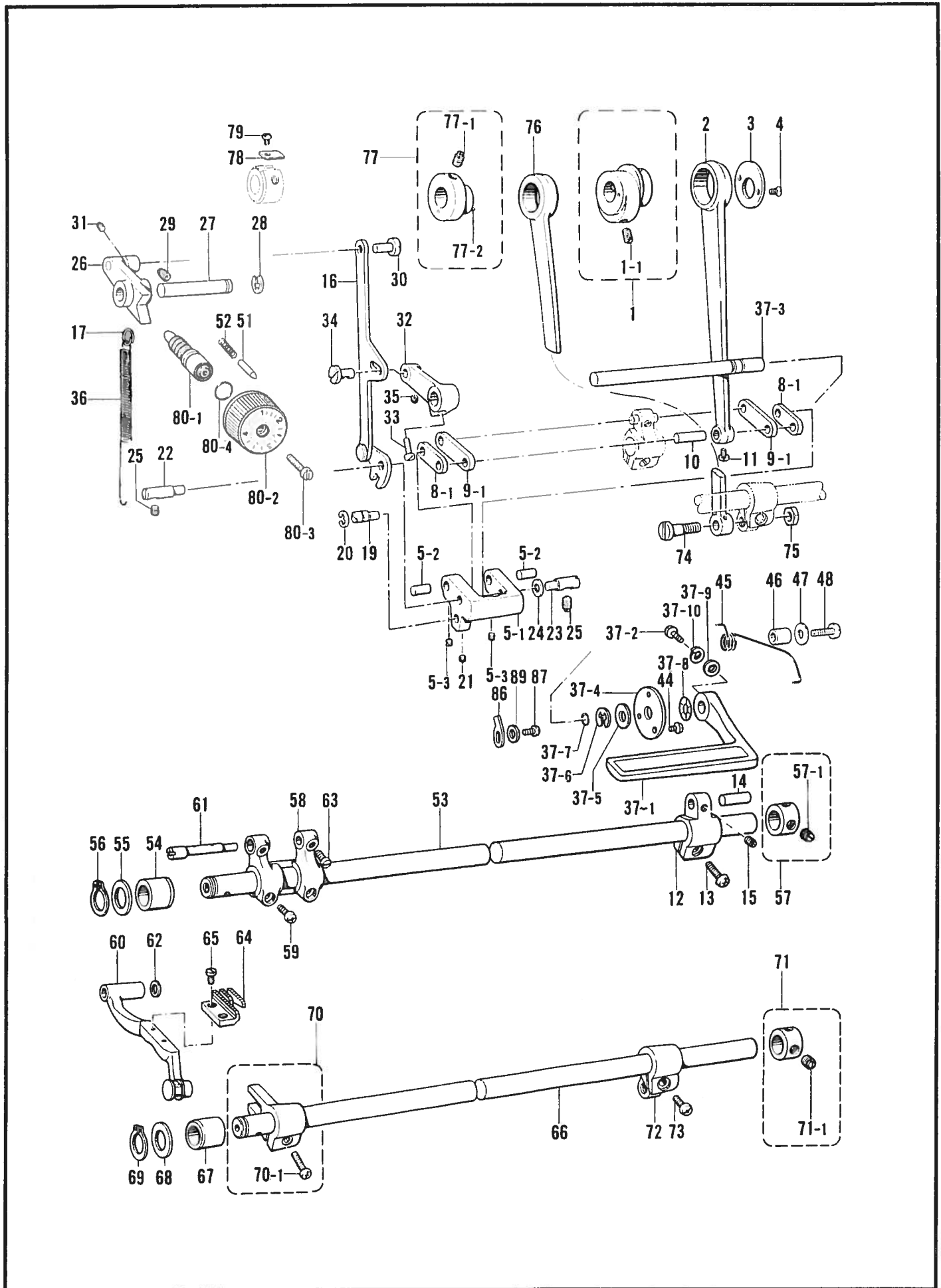



E. 送り関係 / Feed mechanism / Transportvorrichtung / Mécanisme de l'entraînement  
/ Mecanismo de la alimentación

REF.NO.	CODE	Q'TY	ヒンメイ	NAME OF PARTS	RM
52	100328001	1	メモリーチキメピンバネ	SPRING	
53	S02568121	1	スイハイオクリジク	FEED ROCK SHAFT	
54	S31014020	1	メタル19.3	BUSH 19.3	
55	156243021	1	オクリジクスラストリング	THRUST RING	
56	048150142	1	トメワジクヨウC15	RETAINING RING, C15	
57	183493021	1	オクリジクセットカラークミ	FEED SHAFT SET COLLAR ASSY	
57-1	101706001	2	トメネジ6.35	SET SCREW, SM6.35	
58	156244020	1	スイハイオクリダイウデ	FEED ROCK BRACKET ARM	
59	062681212	2	ナベコ437-40X12	SCREW, PAN SM4.37-40X12	
60	S02569121	1	オクリダイクミ	FEED BRACKET ASSY	
61	S25349021	1	オクリダイジク	FEED BRACKET SHAFT	
62	158722021	1	ザガネ4.2	WASHER, 4.2	
63	120990001	2	アタマツキトメネジ4.37	SET SCREW, SM4.37	
64	※	1	オクリバ	FEED DOG	
65	100080003	2	シメネジ3.18	SCREW, SM3.18	
66	S02574121	1	ジヨウゲオクリジク	FEED LIFTING ROCK SHAFT	
67	S31014020	1	メタル19.3	BUSH 19.3	
68	156243021	1	オクリジクスラストリング	THRUST RING	
69	048150142	1	トメワジクヨウC15	RETAINING RING, C15	
70	180322021	1	ジヨウゲオクリウデクミ	FEED LIFTING ROCK SHAFT CRANK ASSY	
70-1	118217001	1	ジヨウゲオクリウデ	FEED LIFTING ROCK SHAFT CRANK	
70-2	062681412	1	ナベコ437-40X14	SCREW, PAN SM4.37-40X14	
71	183493021	1	オクリジクセットカラークミ	FEED SHAFT SET COLLAR ASSY	
71-1	101706001	2	トメネジ6.35	SET SCREW, SM6.35	
72	S02575000	1	ジヨウゲオクリジクウデ	FEED LIFTING ROCK SHAFT CRANK	
73	062711212	1	ナベコ476-32X12	SCREW, PAN SM4.76-32X12	
74	147509021	1	ダンネジ7.14	SHOULDER SCREW, SM7.14	
75	104689002	1	ナツト7.14	NUT, SM7.14	
76	118758021	1	ジヨウゲオクリレンカン	FEED LIFTING CONNECTING ROD	
77	※	1	ヘンシンリンネジツキ	ECCENTRIC WHEEL WITH SCREW	
77-1	151604001	2	トメネジ5.95	SET SCREW, SM5.95	
77-2	047200642	1	スプリングピンAW2	PIN, SPRING ROLL AW2	
78	159690021	1	オクリカムストツパー	FEED CAM STOPPER	
79	062670412	1	ナベコ357-40X4	SCREW, PAN SM3.57-40X4	
80	※	1	オクリメモリアイヤルクミ	STITCH LENGTH DIAL ASSY	
80-1	S06999021	1	オクリチヨウセツネジ	ADJUST SCREW	
80-2	※	1	オクリメモリアイヤル	STITCH LENGTH DIAL	
80-3	S21514121	1	シメネジ4.76	SCREW, SM4.76	
80-4	108549001	1	Oリング	O RING	
80-5	142746022	1	メモリアイタオサエ	PLATE SUPPORT	
36	S02558201	1	<For "-1,-3"> ヒキバネ	SPRING	
36	S03818101	1	<For "-5"> ヒキバネH	SPRING (H)	
45	S01676101	1	<For "-1"> レバーモッドシバネ	SPRING	
45	156974101	1	<For "-3,-5"> レバーモッドシバネ	SPRING	
86	S01753021	1	<For "-1,-3"> ストツパ	STOPPER	
87	062680812	1	ナベコ437-40X8	SCREW, PAN SM4.37-40X8	
89	110735022	1	ザガネ	WASHER	

F. カマ関係 / Rotary hook mechanism / Greifervorrichtung / Mécanisme du crochet rotatif / Mecanismo del cangrejo

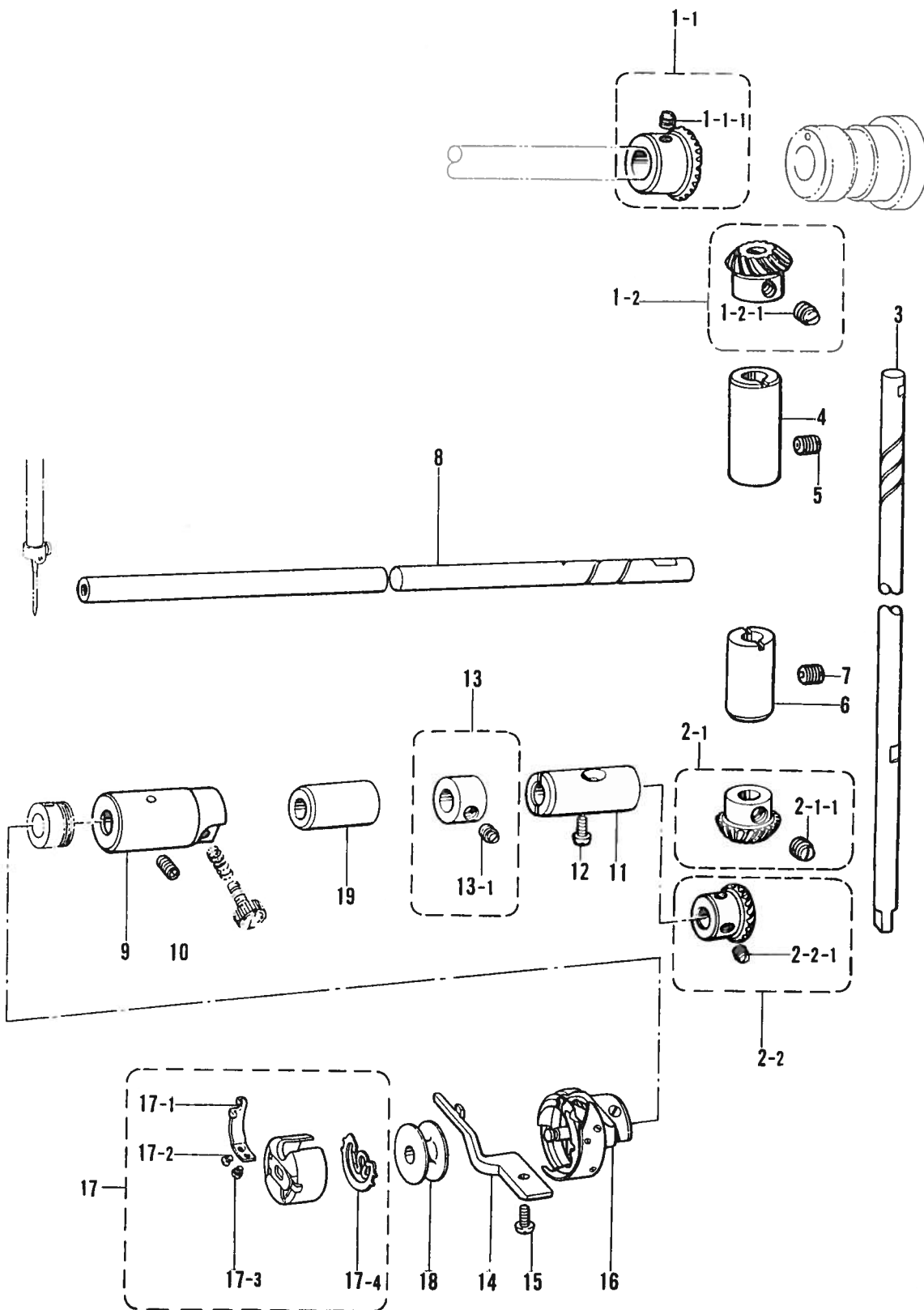

877-101-301

F. カマ関係 / Rotary hook mechanism / Greifervorrichtung / Mécanisme du crochet rotatif / Mecanismo del cangrejo

REF.NO.	CODE	Q'TY	ヒンメイ	NAME OF PARTS	RM
1-1	180891001	1	ウワジクベヘルギヤクミ	UPPER SHAFT BEVEL GEAR ASSY	
1-1-1	100251001	2	トメネジ6.35	SET SCREW, SM6.35	
1-2	180892001	1	タテジクカサハグルマUクミ	VERTICAL BEVEL GEAR (U) ASSY	
1-2-1	100251001	2	トメネジ6.35	SET SCREW, SM6.35	
2-1	180885001	1	タテジクカサハグルマDクミ	VERTICAL BEVEL GEAR (D) ASSY	
2-1-1	100251001	2	トメネジ6.35	SET SCREW, SM6.35	
2-2	180886001	1	シタジクベヘルギヤクミ	LOWER SHAFT BEVEL GEAR ASSY	
2-2-1	100251001	2	トメネジ6.35	SET SCREW, SM6.35	
3	145516021	1	タテジク	VERTICAL SHAFT	
4	142708020	1	タテジクメタルU	VERTICAL SHAFT BUSH (D)	
5	013760610	1	トメネジ5.95クボミ	SET SCREW, (CP) SM5.95	
6	S31026020	1	タテジクメタルD	VERTICAL SHAFT BUSH (D)	
7	013761410	1	トメネジ5.95クボミ	SET SCREW, (CP) SM5.95	
8	109160021	1	シタジク	LOWER SHAFT	
9	118761021	1	シタジクメタルL	LOWER SHAFT BUSH (L)	
10	014680622	1	アナトメネジ4.37クボミ	SET SCREW, SOCKET (CP) SM4.37	
11	104520020	1	シタジクメタルR	LOWER SHAFT BUSH (R)	
12	121007001	1	アタマツキトメネジ4.37	SET SCREW, SM4.37	
13	181995021	1	セツトカラークミ	SET SCREW COLLAR ASSY	
13-1	101706001	2	トメネジ6.35	SET SCREW, SM6.35	
15	107407003	1	シメネジ4.37	SCREW, SM4.37	
17	S06573001	1	ボビンケースクミ	BOBBIN CASE ASSY	
17-1	183388001	1	ボビンケースチヨウシバネ	TENSION SPRING	
17-2	183389001	1	チヨウシバネチヨウセツネジ	ADJUST SCREW	
17-3	183390001	1	チヨウシバネトメネジ	SET SCREW	
17-4	S06594001	1	クウテンボウシバネ	BOBBIN TENSION SPRING	
19	S31027020	1	シタジクメタルM	LOWER SHAFT BUSH (M)	
14	S02602021	1	<For "-1,-3"> ウチカマトメ	BOBBIN CASE HOLDER	
16	159907001	1	コウソクカマB	ROTARY HOOK (B) ASSY	
18	146290001	1	ボビン	BOBBIN	
14	159324021	1	<For "-5"> ウチカマトメ	BOBBIN CASE HOLDER	
16	S03252001	1	コウソクカマB	ROTARY HOOK (B) ASSY	
18	117132001	1	ボビン	BOBBIN	

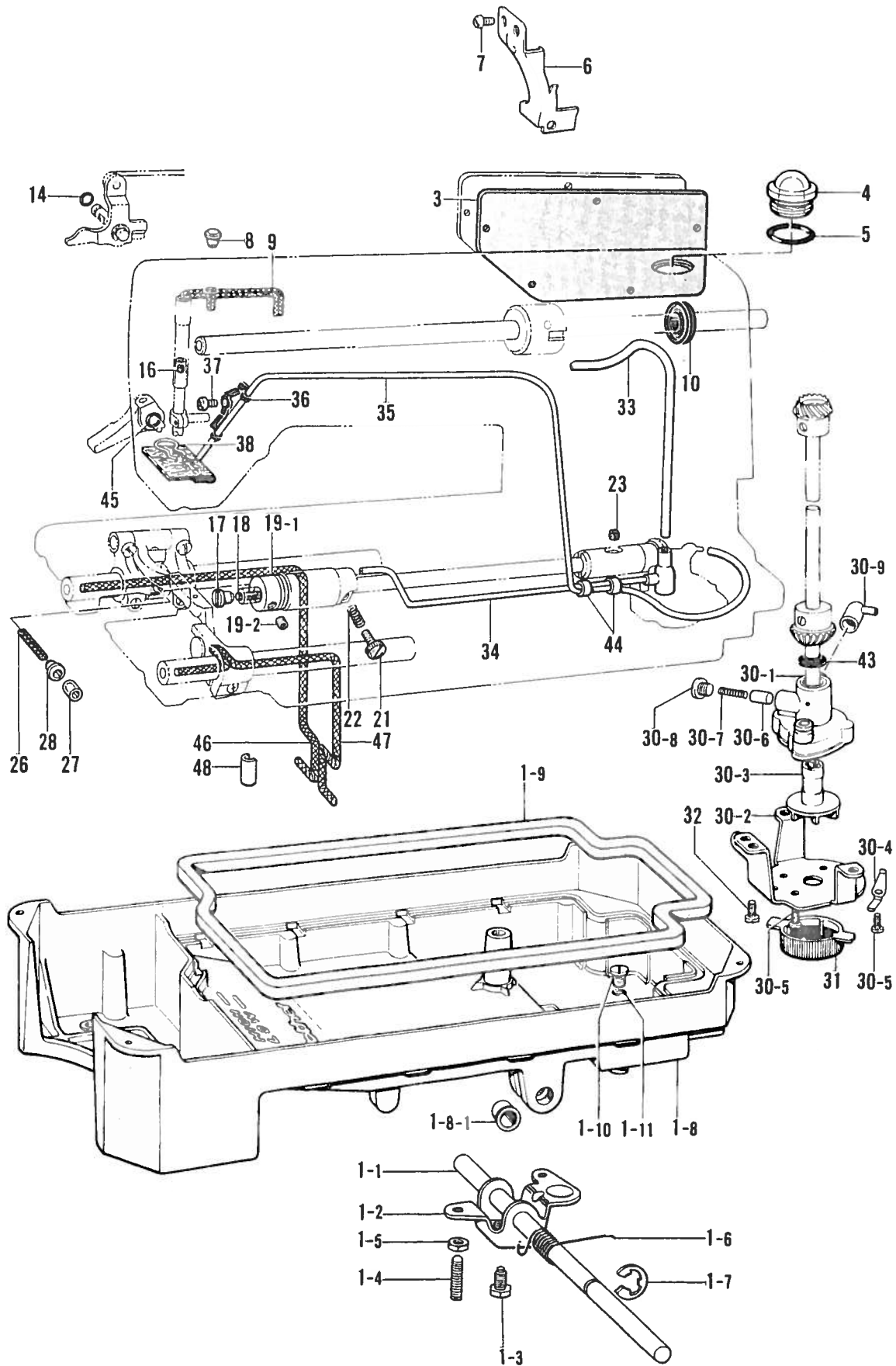

## G. 給油潤滑関係 / Lubrication / Schmierung / Lubrification / Lubricación

REF.NO.	CODE	Q'TY	ヒンメイ	NAME OF PARTS	RM
1	183496221	1	オイルハンクミ	OIL PAN ASSY	
1-1	146036121	1	ヒザアゲヨコジク	KNEE LIFTER SHAFT	
1-2	S09635021	1	ヒザアゲ	KNEE LIFTER	
1-3	146367021	1	ホルト5.95	BOLT, SM5.95	
1-4	104885121	2	トメネジ5.95	SET SCREW, SM5.95	
1-5	100022004	2	ナツト5.95	NUT, SM5.95	
1-6	S15889021	1	ヒザアゲネジリバネ	TWIST SPRING	
1-7	146293001	1	トメワE10	RETAINING RING, E10	
1-8	149580321	1	オイルハン	OIL PAN	
1-8-1	149578020	2	ヨコジクブツシュ	BUSH	
1-9	146040001	1	オイルハツキング	PACKING	
1-10	140518001	1	シメネジ7.94	SCREW, SM7.94	
1-11	081007070	1	OリングP7	O RING, P7	
3	S35531020	1	ガワイタハツキン	REAR COVER PACKING	
4	S02606020	1	ユリヨウケイマド	OIL GAUGE WINDOW	
5	081014670	1	OリングPW14	O RING, PW14	
6	S03253121	1	テンビンオイルヨケイタ	OIL STOPPER PLATE	
7	062670516	2	ナベコ357-40X5	SCREW, PAN SM3.57-40X5	
8	111865009	1	オイルメクラセン	CAP, 6	
9	108804001	1	クミヒモ4X4	WICK 4X4 (L = 510)	
10	101487000	1	オイルシール	OIL SEAL	
14	081001670	1	OリングPW1	O RING, PW1	
17	109173101	1	オイルアナフタネジ	OIL CAP SCREW	
18	106436001	1	フェルト	FELT	
19	S06684021	1	カマアブラキリクミ	OIL REJECTOR ASSY	
19-1	S02608021	1	カマアブラキリ	OIL REJECTOR	
19-2	014680422	2	アナトメネジ4.37クボミ	SET SCREW, SOCKET (CP) SM4.37	
21	145534001	1	オイルチヨウセツネジ	ADJUST SCREW	
22	116794001	1	オシバネ	SPRING, COMPRESSION	
23	107155001	1	フェルト	FELT	
26	S40017000	1	クミヒモ360	WICK (L = 360)	
27	S40016001	1	ビニルチューブ2X25	OIL TUBE, 2X25	
30	183850021	1	ポンプタイクミ	PUMP BODY ASSY	
30-1	S32348021	1	ポンプタイ	PUMP BODY	
30-2	144869022	1	ポンプキヤク	PUMP SUPPORT	
30-3	148849021	1	ポンプカイテンヨク	PUMP PROPELLER	
30-4	144874021	2	フィルターバネ	SPRING	
30-5	062670812	4	ナベコ3.57-40X8	SCREW, PAN SM3.57-40X8	
30-6	144875021	1	プランジャー	PLUNGER	
30-7	144876001	1	プランジャーバネ	PLUNGER SPRING	
30-8	112467022	1	シメネジ6.35	SCREW, SM6.35	
30-9	144878001	1	チューブジョイントB	OIL TUBE JOINT (B)	
31	144872121	1	ポンプフィルター	PUMP FILTER	
32	062680712	3	ナベコ437-40X7	SCREW, PAN SM4.37-40X7	
33	S03592020	1	オイルチューブU	OIL TUBE (U)	
34	S32349001	1	オイルチューブDクミ	OIL TUBE (D) ASSY	
35	145543001	1	チューブクミ	TUBE ASSY	
36	145547021	1	チューブホルダ	TUBE HOLDER	
37	062670516	1	ナベコ357-40X5	SCREW, PAN SM3.57-40X5	
38	145737021	1	フェルトオサエ	FELT SUPPORT	
43	146196001	1	アブラヨケ	OIL STOPPER	
44	146253000	2	チューブ	OIL TUBE (L = 5)	
45	081004070	1	OリングP4	O RING, P4	
46	108808001	1	クミヒモ6X6	WICK (6X6)	
47	S08003000	1	クミヒモ	WICK (L = 380)	
48	S08004021	1	クミヒモササエ	WICK SUPPORT	
16	111863001	1	<For "-5"> ハリボウセン	NEEDLE BAR CORK	

H. 糸通シ関係 / Threading mechanism / Fadenführungs-vorrichtung / Mécanisme de l'enfilage / Mecanismo del enhebrado

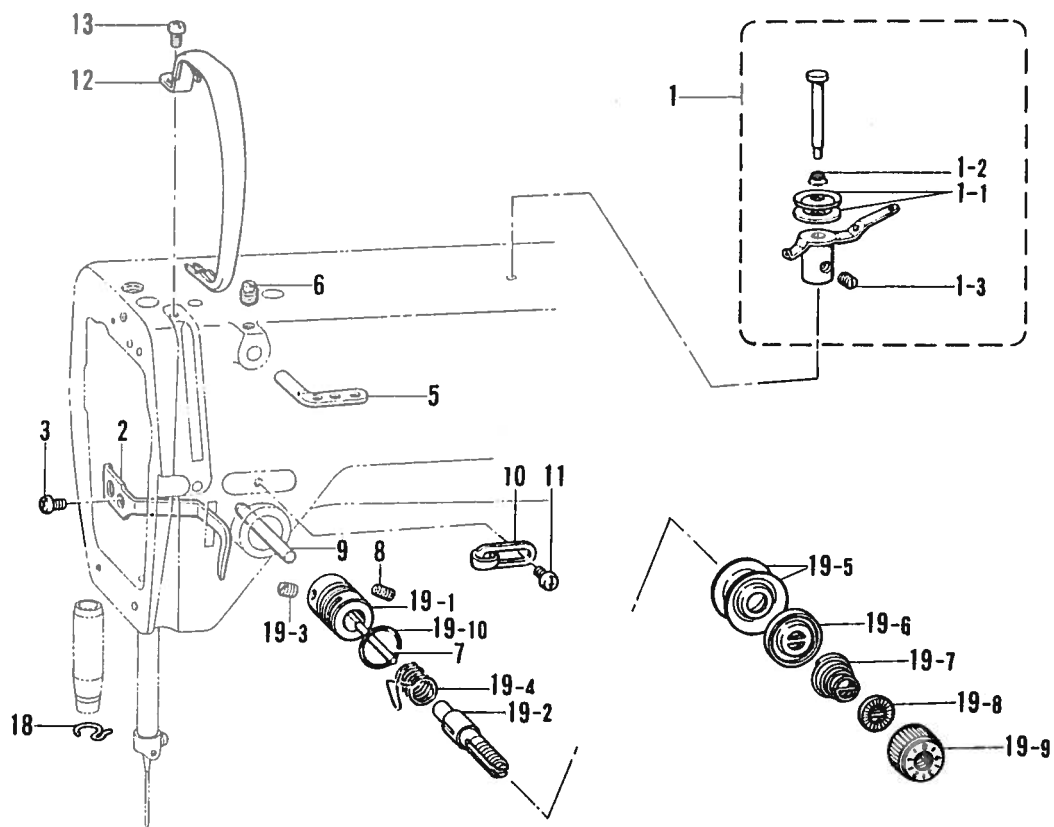

H. 糸通シ関係 / Threading mechanism / Fadenführungsrichtung / Mécanisme de l'enfilage / Mecanismo del enhebrado

REF.NO.	CODE	Q'TY	ヒンメイ	NAME OF PARTS	RM
1	144502001	1	ブレテンションクミ	PRE-TENSION ASSY	
1-1	144504001	2	イトアンナイサラ	THREAD GUIDE DISC	
1-2	144505000	1	イトアンナイバネ	SPRING	
1-3	102716004	1	トメネジ4.37	SET SCREW, SM4.37	
2	111469101	1	オサエボウダキイトアンナイ	THREAD GUIDE	
3	062680712	1	ナベコ437-40X7	SCREW, PAN SM4.37-40X7	
5	114931001	1	ミツメイトカケ	THREAD RETAINER	
6	151602002	1	トメネジ4.37	SET SCREW, SM4.37	
7	100400000	1	イトユルメピン	PIN	
8	103950003	1	トメネジ5.95	SET SCREW, SM5.95	
9	145526021	1	イトユルメボウ	TENSION RELEASE BAR	
10	145522001	1	アームイトアンナイR	ARM THREAD GUIDE (R)	
11	S19056001	1	バインド357-40X6	SCREW, BIND SM3.57-40X6	
12	S02614124	1	テンピンカバー	THREAD TAKE-UP COVER	
13	062680712	1	ナベコ437-40X7	SCREW, PAN SM4.37-40X7	
18	100573001	1	ハリボウメタルDイトアンナイ	NEEDLE BAR BUSH (D) THREAD GUI DE	
19-1	S03254001	1	イトチヨウシボウタイ	THREAD TENSION BRACKET	
19-2	116922001	1	イトチヨウシボウ	TENSION STUD	
19-3	100402004	1	トメネジ3.57	SET SCREW, SM3.57	
19-4	S02620001	1	イトトリバネ	SPRING	
19-5	145446001	2	イトチヨウシサラ	TENSION DISC	
19-6	159805001	1	イトチヨウシサラオサエ	TENSION DISC PRESSER	
19-8	S12441001	1	チヨウシバネウエザガネ	WASHER	
19-9	S31032001	1	イトチヨウシナツト	TENSION NUT	
19-10	114294001	1	Oリング	O RING	
<hr/>					
19	S31031001	1	<For "-1,-3"> イトチヨウシボウダイクミ	THREAD TENSION BRACKET ASSY	
19-7	104525001	1	イトチヨウシバネ	TENSION SPRING	
19	S31034001	1	<For "-5"> イトチヨウシボウダイクミ	THREAD TENSION BRACKET ASSY	
19-7	S04632001	1	イトチヨウシバネ	TENSION SPRING	

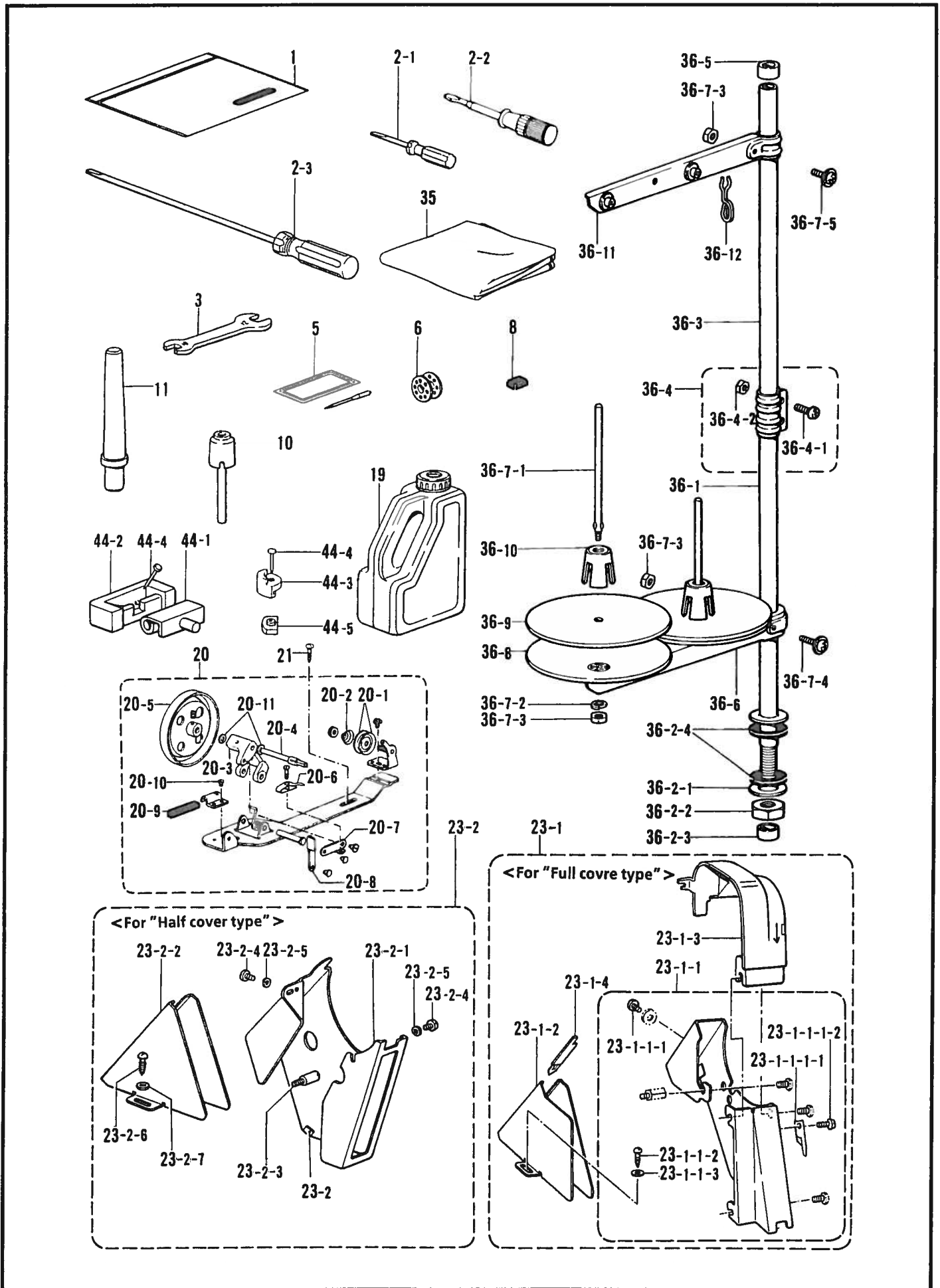



Z. 付属品関係 / Accessories / Zubehör / Accessoires / Accesorios

REF.NO.	CODE	Q'TY	ヒンメイ	NAME OF PARTS	RM
1	S35730021	1	フソクヒンポリフクロ	ACCESSORY BAG	
2-1	142443021	1	ネジマワシ1.9X52	SCREW DRIVER, 1.9X52	
2-2	118837021	1	ネジマワシ3.4X70	SCREW DRIVER, 3.4X70	
2-3	S17774021	1	ネジマワシ4.7X250	SCREW DRIVER, 4.7X250	
3	100887021	1	スパナ8X9	WRENCH 8X9	
8	112525020	1	シュウジンマグネット	MAGNET	
10	S09634020	1	ヒザアゲオシボウ	KNEE LIFTER COMPLYING BAR	
11	100477029	1	マクラ	PILLOW	
19	S35822021	1	オイルタンク	OIL TANK	
21	100666022	2	マルモクネジ5.5X20	WOOD SCREW, ROUND M5.5X20	
35	S35732021	1	トウブカバー	HEAD COVER	
36	S35829021	1	イトタテダイクミ2DR	COTTON STAND ASSY 2DR	
36-1	S36064021	1	コラムパイプD	COLUMN PIPE (D)	
36-2	S02777021	1	パイプDネジセットB	PIPE (D) SCREW SET	
36-2-1	150206022	1	ヒラザガネ16	WASHER, PLAIN 16	
36-2-2	S36062021	1	6カクナツM16	NUT, M16	
36-2-3	S35635020	1	コラムキャップ	COLUMN CAP	
36-2-4	S01005020	2	イトタテゴム	RUBBER WASHER	
36-3	150172023	1	コラムパイプ	COLUMN PIPE	
36-4	S35828021	1	コラムジョイントクミ	COLUMN JOINT ASSY	
36-4-1	S35826021	2	ナベコ5X14	SCREW, PAN M5X14	
36-4-2	S35827021	2	1シユナツ5	NUT, 1 M5	
36-5	S35635020	1	コラムキャップ	COLUMN CAP	
36-6	S02778022	1	スプールホルダー2	SPOOL HOLDER 2	
36-7	S35833021	1	スプールネジセット2	SPOOL SCREW SET 2	
36-7-1	150179022	2	スプールジクB	SPOOL SHAFT (B)	
36-7-2	S35830021	2	バネザガネ2-5	WASHER, SPRING 2-5	
36-7-3	S35827021	4	1シユナツ5	NUT, 1 M5	
36-7-4	S35831021	1	+ナベザクミ5X30A	SCREW, PAN (P WASHER) M5X30A	
36-7-5	S35832021	1	+ナベザクミ5X14A	SCREW, PAN (P WASHER) M5X14A	
36-8	150180021	2	ウケザラ	SPOOL STAND BASE	
36-9	150182020	2	スプールのマット	SPOOL MAT	
36-10	126863021	2	スプールのクッション	SPOOL CUSHION	
36-11	S02786022	1	スレッドハンガークミ2	THREAD HANGER ASSY, 2	
36-12	S02747121	1	イトカケバネ	SPRING	
44	S35736021	1	ラバーヒンジクミ	RUBBER HINGE ASSY	
44-1	143882021	2	トウブヒンジ	HEAD HINGE	
44-2	143910029	2	トウブヒンジウケゴム	RUBBER CUSHION	
44-3	S01302029	4	トウブシキゴム	HEAD CUSHION	
44-4	109714020	8	クギ	NAIL	
44-5	146004021	4	オイルパンクッション	OIL PAN CUSHION	
5	100265031	4	<For "-1"> ミシンハリDBX1	NEEDLE DBX1 (#11)	
5	100265034	4	<For "-3"> ミシンハリDBX1	NEEDLE DBX1 (#14)	
5	107415014	4	<For "-3TR,-3A"> ミシンハリDPX5	NEEDLE DPX5 (#14)	
5	100265042	4	<For "-5"> ミシンハリDBX1	NEEDLE DBX1 (#22)	
6	146290001	3	<For "-1,-3"> ボビン	BOBBIN	
6	117132001	3	<For "-5"> ボビン	BOBBIN	

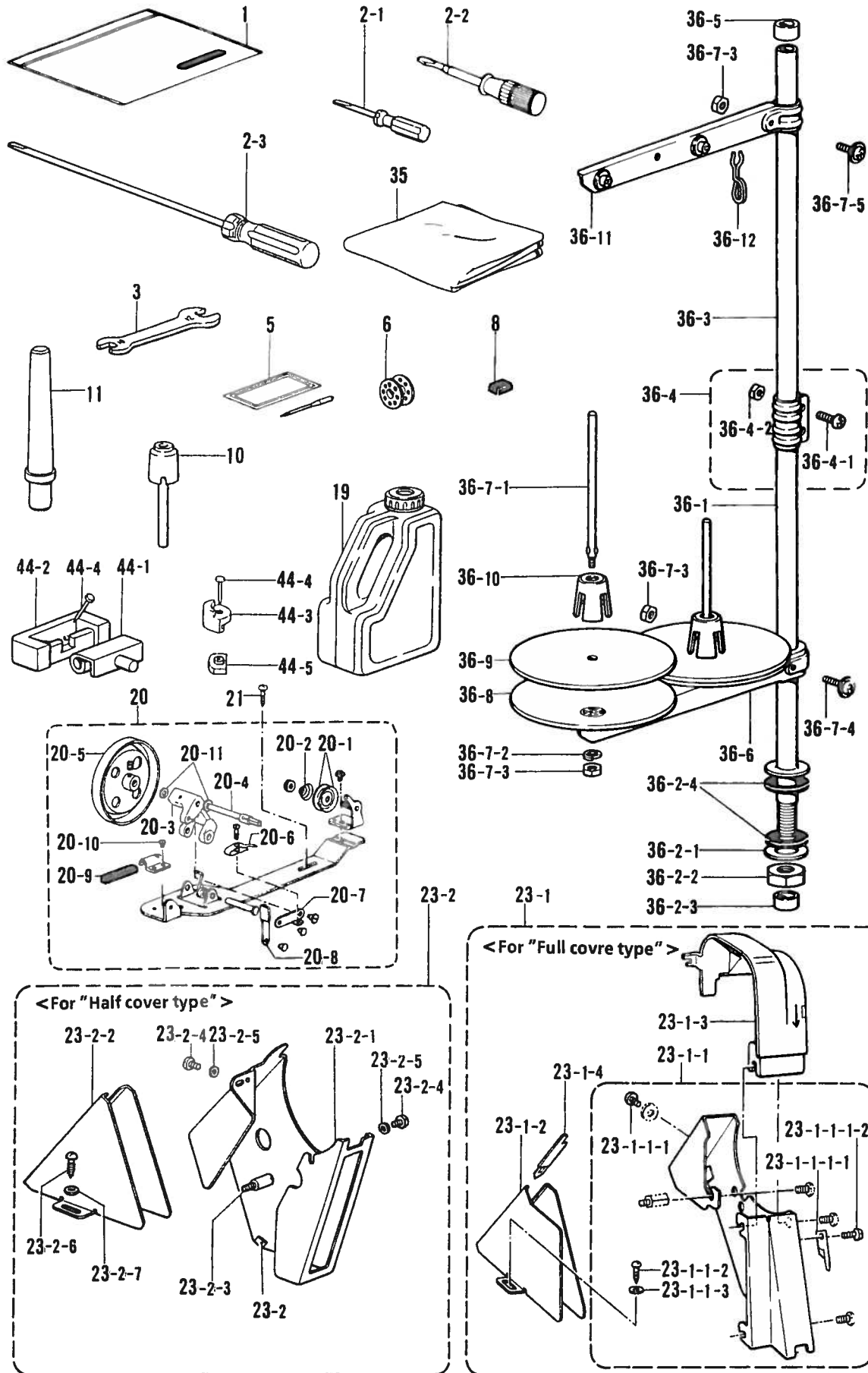





Z. 付属品関係 / Accessories / Zubehör / Accessoires / Accesorios

REF.NO.	CODE	Q'TY	ヒンメイ	NAME OF PARTS	RM
			<For "Full cover type">		
20	S14420020	1	イトマキクミ	BOBBIN WINDER ASSY	
20-1	145446003	2	イトチヨウシサラ	TENSION DISC	
20-2	100401021	1	イトチヨウシバネ	SPRING	
20-3	S14422001	1	イトマキジクウケ	BOBBIN WINDER SHAFT SUPPORT	
20-4	S15133021	1	イトマキジク	BOBBIN WINDER SHAFT	
20-5	S14424021	1	イトマキクルマ	BOBBIN WINDER	
20-6	100656021	1	ボビンオサエ	BOBBIN PRESSER	
20-7	100658021	1	ボビンオサエウデ	BOBBIN PRESSER ARM	
20-8	S14426022	1	ボビンオサエダイ	BOBBIN PRESSER BRACKET	
20-9	100662021	1	イトマキクルマカイトンドメ	BOBBIN WINDER WHEEL STOPPER	
20-10	100664021	1	カイトンドメオサエ	WHEEL STOPPER HOLDER	
20-11	142711021	1	ファイバーワツシヤ	WASHER	
23-1	S37862021	1	ベルトカバーソウクミ	BELT COVER SET	
23-1-1	183658229	1	ベルトカバークミA	BELT COVER ASSY (A)	
23-1-1-1	S15172129	1	ベルトカバー	BELT COVER	
23-1-1-1-1	S15164021	1	メス	KNIFE	
23-1-1-1-2	062680512	1	ナベコ437-40X5	SCREW, PAN SM4.37-40X5	
23-1-1-1	100257020	1	シメネジ3.57	SCREW, SM3.57	
23-1-1-2	100666022	2	マルモクネジ5.5X20	WOOD SCREW, ROUND M5.5X20	
23-1-1-3	S35824021	2	ヒラザガネシヨウ5.56	WASHER, PLAIN S 5.56	
23-1-2	S14428029	1	ベルトカバーD	BELT COVER (D)	
23-1-3	S37161021	1	ベルトカバーUC	BELT COVER, UC	
23-1-4	S37264021	1	ベルトカバーDフタS	BELT COVER (D) LID (S)	
			<For "Half cover type">		
20	117963120	1	イトマキクミ	BOBBIN WINDER ASSY	
20-1	145446001	2	イトチヨウシサラ	TENSION DISC	
20-2	100401021	1	イトチヨウシバネ	SPRING	
20-3	117967001	1	イトマキジクウケ	BOBBIN WINDER SHAFT SUPPORT	
20-4	117970021	1	イトマキジク	BOBBIN WINDER SHAFT	
20-5	S18634021	1	イトマキクルマ	BOBBIN WINDER	
20-6	100656021	1	ボビンオサエ	BOBBIN PRESSER	
20-7	100658021	1	ボビンオサエウデ	BOBBIN PRESSER ARM	
20-8	100660023	1	ボビンオサエダイ	BOBBIN PRESSER BRACKET	
20-9	100662021	1	イトマキクルマカイトンドメ	BOBBIN WINDER WHEEL STOPPER	
20-10	100664021	1	カイトンドメオサエ	WHEEL STOPPER HOLDER	
20-11	142711021	2	ファイバーワツシヤ	WASHER	
23-2	S35825029	1	ベルトカバークミA	BELT COVER ASSY (A)	
23-2-1	147853029	1	ベルトカバーUE	BELT COVER (UE)	
23-2-2	147854029	1	ベルトカバーD	BELT COVER (D)	
23-2-3	147855022	1	ベルトカバースタツDA	BELT COVER STUD (A)	
23-2-4	062680812	2	ナベコ437-40X8	SCREW, PAN SM4.37-40X8	
23-2-5	S35823021	2	バネザガネ2-4.37	WASHER, SPRING M 2-4.37	
23-2-6	100666022	2	マルモクネジ5.5X20	WOOD SCREW, ROUND M5.5X20	
23-2-7	S35824021	2	ヒラザガネシヨウ5.56	WASHER, PLAIN S 5.56	

Sp. 仕様別部品一覧表 / DIFFERENT PARTS LIST / ZUBEHÖRLISTE  
 / LISTE DES PIÈCES ACCESSOIRES / LISTA DE PIEZAS DE CALIBRADORES

Ref. No.	ヒンメイ / NAME OF PARTS	仕様 / Specification				
		- 1 薄物用 / For Thin Materials	- 3 中厚物用 / For Medium Thick Materials	- 3TR 中厚物用 / For Medium Thick Materials	- 3A 中厚物用 / For Medium Thick Materials	- 5 厚物用 / For Thick Materials
C-17	ハリボウ / NEEDLE BAR	S14811021 (DB)	←	S14815021 (DP)	←	S02811021 (DB)
C-18	ミシンハリ / NEEDLE	100265031 DB×1 (#11)	100265034 DB×1 (#14)	107415014 DPX5 (#14)	←	100265042 DBX1 (#22)
C-22	ハリイタ / NEEDLE PLATE	S03884321 (E16)	111859321 (E18)	100266021 (B18)	111859321 (E18)	150792021 (H26)
D-5	オサエバネ / PRESSER SPRING	147514001	141728001	←	←	←
D-7	オサエクミ / PRESSER FOOT ASSY	153037221	113280121	←	S36905021	150789121
E-1	スイハイヘンシンリンネジツキ / LEVEL FEED ECCENTRIC WHEEL	S02552021	←	156946021	S02552021	156946021
E-64	オクリバ / FEED DOG	S02748001 S03885001	S02742001 111860101	----- S02742001	----- 111860101	S02743001 150793001
E-77	ヘンシンリンネジツキ / ECCENTRIC WHEEL WITH SCREW	S02576021	←	159708021	S02576021	159706021
E-80	オクリメモリダイヤルクミ / STITCH LENGTH DIAL ASSY	S31015021	←	S31018021	S31015021	S31018021
E-80-2	オクリメモリダイヤル / STITCH LENGTH DIAL	S31016001	←	S31019001	S31016001	S31019001
H-19	イトチヨウシボウダイクミ / THREAD TENSION BRACKET ASSY	S31031001	←	←	←	S31034001
H-19-7	イトチヨウシバネ / TENSION SPRING	104525001	←	←	←	S04632001

Wa. 警告ラベル / Warning labels / Warnschilder / Etiquettes d'avertissement / Etiquetas de advertencia

	品名 / Name of parts	Size(mm)	Code
	操作注意ラベル・和	40 × 64	S38350-001
		52 × 84	S38350-002
	Label, operation Eng.	40 × 64	S38349-001
		52 × 84	S38349-002
	ワーニングマーク Mark, injury	L=16 R=0.8	S36924-001
	PEマーク Mark, PE	7.5 × 12.5	S37059-001
	アースマーク Mark, grounding	φ12	S37060-001

877-101-050

索引 / INDEX / VERZEICHNIS / INDEX / INDICE

CODE	REF.NO.	Page
S00879021	D - 34	8
S00909021	C - 1-2	6
S01005020	Z - 36-2-4	20
S01020022	D - 10	8
S01302029	Z - 44-3	20
S01676101	E - 45	12
S01753021	E - 86	12
S01998001	D - 13	8
S02552021	E - 1	10
	Sp - E-1	23
S02558201	E - 36	12
S02568121	E - 53	12

CODE	REF.NO.	Page
S02569121	E - 60	12
S02574121	E - 66	12
S02575000	E - 72	12
S02576021	Sp - E-77	23
S02602021	F - 14	14
S02606020	G - 4	16
S02608021	G - 19-1	16
S02614124	H - 12	18
S02617001	A - 24-4	2
S02620001	H - 19-4	18
S02742001	Sp - E-64	23
S02743001	Sp - E-64	23
S02747121	Z - 36-12	20
S02748001	Sp - E-64	23
S02777021	Z - 36-2	20

CODE	REF.NO.	Page
S02778022	Z - 36-6	20
S02786022	Z - 36-11	20
S02811021	C - 17	6
	Sp - C-17	23
S03252001	F - 16	14
S03253121	G - 6	16
S03254001	H - 19-1	18
S03592020	G - 33	16
S03818101	E - 36	12
S03884321	C - 22	4
	Sp - C-22	23
S03885001	Sp - E-64	23
S04228001	E - 17	10
S04632001	H - 19-7	18
	Sp - H-19-7	23

CODE	REF.NO.	Page
S05898021	E - 5	10
S06325021	C - 1-2	4
S06573001	F - 17	14
S06594001	F - 17-4	14
S06684021	G - 19	16
S06999021	E - 80-1	12
S08003000	G - 47	16
S08004021	G - 48	16
S09621001	A - 21	2
S09634020	Z - 10	20
S09635021	G - 1-2	16
S12441001	H - 19-8	18
S13163001	C - 11-2-1	6
S13385001	D - 8	8
S14420020	Z - 20	22
S14422001	Z - 20-3	22
S14424021	Z - 20-5	22
S14426022	Z - 20-8	22
S14428029	Z - 23-1-2	22
S14811021	C - 17	4
	Sp - C-17	23
S14814001	C - 21	4
S14815021	C - 17	4
	Sp - C-17	23
S15133021	Z - 20-4	22
S15164021	Z - 23-1-1-1-1	22
S15172129	Z - 23-1-1-1	22
S15889021	G - 1-6	16
S17774021	Z - 2-3	20
S18634021	Z - 20-5	22
S19056001	H - 11	18
S21514121	E - 80-3	12
S25349021	E - 61	12
S28919021	D - 32	8
S31006001	D - 25	8
S31010021	D - 23	8
S31012001	D - 3	8
S31013001	D - 33	8
S31014020	E - 54	12
	E - 67	12
S31015021	Sp - E-80	23
S31016001	Sp - E-80-2	23
S31018021	Sp - E-80	23
S31019001	Sp - E-80-2	23
S31026020	F - 6	14
S31027020	F - 19	14
S31031001	H - 19	18
	Sp - H-19	23
S31032001	H - 19-9	18
S31034001	H - 19	18
	Sp - H-19	23
S31885001	B - 1-8	2
S31952021	D - 28	8
S32348021	G - 30-1	16
S32349001	G - 34	16
S32921120	E - 37-1	10
S32922021	E - 37-3	10
S33689002	C - 26	4
S34287021	C - 11-1	4
S34290021	C - 11-2	6
S34756021	B - 1-5	2
S35525021	A - 24	2
S35526021	A - 24-1	2
S35529020	A - 24-2	2
S35530021	A - 6	2
S35531020	G - 3	16
S35543121	E - 37	10
S35635020	Z - 36-2-3	20
	Z - 36-5	20
S35730021	Z - 1	20
S35732021	Z - 35	20
S35736021	Z - 44	20
S35817021	C - 15	4
S35818021	E - 37-5	10
S35819021	E - 47	10

CODE	REF.NO.	Page
S35820021	B - 1-3	2
S35821021	B - 1	2
S35822021	Z - 19	20
S35823021	Z - 23-2-5	22
S35824021	Z - 23-1-1-3	22
	Z - 23-2-7	22
S35825029	Z - 23-2	22
S35826021	Z - 36-4-1	20
S35827021	Z - 36-4-2	20
S35827021	Z - 36-7-3	20
S35828021	Z - 36-4	20
S35829021	Z - 36	20
S35830021	E - 37-10	10
	Z - 36-7-2	20
S35831021	Z - 36-7-4	20
S35832021	Z - 36-7-5	20
S35833021	Z - 36-7	20
S36062021	Z - 36-2-2	20
S36064021	Z - 36-1	20
S36905021	D - 7	8
	Sp - D-7	23
S36924001	Wa	24
S37059001	Wa	24
S37060021	Wa	24
S37161021	Z - 23-1-3	22
S37264021	Z - 23-1-4	22
S37333001	E - 37-2	10
S37812021	C - 1	4
S37813021	C - 1	6
S37814021	C - 1-1	4
	C - 1-1	6
S37815021	C - 2	4
S37862021	Z - 23-1	22
S38349021	Wa	24
S38350021	Wa	24
S40016001	G - 27	16
S40017000	G - 26	16
013760610	C - 5	4
	F - 5	14
013761410	E - 1-1	10
	F - 7	14
013781012	C - 12	4
014680422	E - 31	10
	E - 35	10
	G - 19-2	16
014680622	E - 5-3	10
	E - 21	10
	F - 10	14
014761030	E - 29	10
014771022	C - 1-7	4
047200642	E - 77-2	12
048040342	D - 17	8
048060342	E - 20	10
048070342	E - 28	10
048080342	E - 37-6	10
048150142	E - 56	12
	E - 69	12
060670612	A - 24-5	2
062351216	D - 26	8
062670412	E - 79	12
062670516	G - 7	16
	G - 37	16
062670612	A - 22	2
062670712	E - 44	10
062670812	G - 30-5	16
062671012	A - 25	2
062680512	Z - 23-1-1-1-2	22
062680712	G - 32	16
	H - 3	18
	H - 13	18
062680812	A - 28	2
062680812	E - 87	12
	Z - 23-2-4	22
062681012	A - 7	2
062681212	E - 59	12

CODE	REF.NO.	Page
062681412	E - 70-2	12
062711212	E - 73	12
062711412	E - 13	10
	E - 33	10
062760812	A - 26	2
062782512	E - 48	10
081001670	G - 14	16
081004070	G - 45	16
081007070	G - 1-11	16
081014670	G - 5	16
100022004	G - 1-5	16
100032004	C - 23	4
100080003	E - 65	12
100251001	C - 1-7	6
	C - 7-1	4
	F - 1-1-1	14
	F - 1-2-1	14
	F - 2-1-1	14
	F - 2-2-1	14
100257020	Z - 23-1-1-1	22
100260001	C - 16	4
100265031	C - 18	4
	Z - 5	20
	Sp - C-18	23
100265034	C - 18	4
	Z - 5	20
	Sp - C-18	23
100265036	C - 18	6
100265039	C - 18	6
100265042	C - 18	6
	Z - 5	20
	Sp - C-18	23
100266021	C - 22	4
	Sp - C-22	23
100328001	E - 52	12
100400000	H - 7	18
100401021	Z - 20-2	22
	Z - 20-2	22
100402004	H - 19-3	18
100463021	B - 1-2	2
100477029	Z - 11	20
100573001	H - 18	18
100645023	A - 29	2
100656021	Z - 20-6	22
	Z - 20-6	22
100658021	Z - 20-7	22
	Z - 20-7	22
100660023	Z - 20-8	22
100662021	Z - 20-9	22
	Z - 20-9	22
100664021	Z - 20-10	22
	Z - 20-10	22
100666022	Z - 21	20
	Z - 23-1-1-2	22
	Z - 23-2-6	22
100887021	Z - 3	20
101487000	G - 10	16
101706001	E - 57-1	12
	E - 71-1	12
	F - 13-1	14
102630021	C - 20	4
102707021	D - 27	8
102716004	H - 1-3	18
103950003	H - 8	18
104449009	A - 8	2
	A - 24-3	2
104450109	A - 9	2
	A - 23	2
104451009	A - 15	2
104464001	C - 1-3	4
	C - 1-3	6
104520020	F - 11	14
104525001	H - 19-7	18
	Sp - H-19-7	23
104564001	E - 37-7	10

CODE	REF.NO.	Page
104619022	B -1-4	2
104689002	E -75	12
104821009	A -11	2
104829121	A -2	2
104830121	A -3	2
104832009	A -10	2
104885121	G -1-4	16
106436001	G -18	16
107155001	G -23	16
107407003	F -15	14
107415011	C -18	6
107415014	C -18	4
	Z -5	20
	Sp -C-18	23
107415022	C -18	6
108520009	A -14	2
108549001	E -80-4	12
108804001	G -9	16
108808001	G -46	16
108960002	E -4	10
109160021	F -8	14
109173101	G -17	16
109714020	Z -44-4	20
109763022	D -11	8
110087021	B -1-7	2
110367001	C -13	4
110735022	E -89	12
111466121	D -1	8
111469101	H -2	18
111859321	C -22	4
	Sp -C-22	23
111860101	Sp -E-64	23
111863001	G -16	16
111865009	G -8	16
112467022	G -30-8	16
112525020	Z -8	20
113280121	D -7	8
	Sp -D-7	23
114294001	H -19-10	18
114561021	C -24-1	4
114931001	H -5	18
114967021	B -1-6	2
115244029	C -25	4
116794001	G -22	16
116922001	H -19-2	18
117132001	F -18	14
	Z -6	20
117242021	C -14	4
117963120	Z -20	22
117967001	Z -20-3	22
117970021	Z -20-4	22
118217001	E -70-1	12
118672021	A -4	2
118734021	E -23	10
118735021	E -24	10
118758021	E -76	12
118761021	F -9	14
118837021	Z -2-2	20
120990001	E -63	12
121007001	F -12	14
122771002	C -24-2	4
126863021	Z -36-10	20
140004001	C -11-1-2	4
	C -11-2-2	6
140518001	G -1-10	16
140553102	C -19	4
140704021	A -5	2
140726020	C -4	4
141208021	D -4	8
141728001	D -5	8
	Sp -D-5	23
142274009	A -12	2
142403001	D -35	8
142443021	Z -2-1	20
142708020	F -4	14

CODE	REF.NO.	Page
142711021	Z -20-11	22
	Z -20-11	22
142746022	E -80-5	12
143882021	Z -44-1	20
143910029	Z -44-2	20
144458001	E -11	10
144502001	H -1	18
144504001	H -1-1	18
144505000	H -1-2	18
144869022	G -30-2	16
144872121	G -31	16
144874021	G -30-4	16
144875021	G -30-6	16
144876001	G -30-7	16
144878001	G -30-9	16
145446001	H -19-5	18
	Z -20-1	22
145446003	Z -20-1	22
145465001	C -11-1-1	4
145471029	C -25	4
145472021	D -2	8
145476021	D -20	8
145478022	D -21	8
145479022	D -22	8
145481021	D -24	8
145502021	E -51	10
145516021	F -3	14
145522001	H -10	18
145526021	H -9	18
145534001	G -21	16
145543001	G -35	16
145547021	G -36	16
145624000	C -11-1-4	4
	C -11-2-4	6
145737021	G -38	16
146004021	Z -44-5	20
146036121	G -1-1	16
146039021	B -1-1	2
146040001	G -1-9	16
146196001	G -43	16
146253000	G -44	16
146290001	F -18	14
	Z -6	20
146293001	G -1-7	16
146327001	C -1-4	4
	C -1-4	6
146331021	C -6	4
146333001	C -1-5	4
	C -1-5	6
146367021	G -1-3	16
147326021	C -15	6
147504021	E -37-4	10
147509021	E -74	12
147514001	D -5	8
	Sp -D-5	23
147777000	C -11-1-3	4
	C -11-2-3	6
147853029	Z -23-2-1	22
147854029	Z -23-2-2	22
147855022	Z -23-2-3	22
148849021	G -30-3	16
149578020	G -1-8-1	16
149580321	G -1-8	16
150172023	Z -36-3	20
150179022	Z -36-7-1	20
150180021	Z -36-8	20
150182020	Z -36-9	20
150206022	Z -36-2-1	20
150384121	D -31	8
150789121	D -7	8
	Sp -D-7	23
150792021	C -22	6
	Sp -C-22	23
150793001	Sp -E-64	23
151308121	E -30	10

CODE	REF.NO.	Page
151308121	E -34	10
151317021	E -46	10
151594001	C -21	6
151601002	E -15	10
151602002	H -6	18
151604001	E -25	10
	E -77-1	12
153037221	D -7	8
	Sp -D-7	23
153484021	E -37-9	10
154347001	D -29	8
155488000	C -11-1-5	4
	C -11-2-5	6
156243021	E -55	12
	E -68	12
156244020	E -58	12
156641001	C -1-6	4
	C -1-6	6
156946021	E -1	10
	Sp -E-1	23
156948021	E -3	10
156949021	E -2	10
156950120	E -5-1	10
156951021	E -5-2	10
156952021	E -8	10
156953021	E -8-1	10
156954021	E -9	10
156955021	E -9-1	10
156956021	E -10	10
156957020	E -12	10
156958021	E -14	10
156966121	E -19	10
156967021	E -22	10
156969021	E -26	10
156970021	E -27	10
156971020	E -32	10
156974101	E -45	12
157969021	A -27	2
158021122	E -16	10
158722021	E -62	12
158727001	C -11-1-6	4
	C -11-2-6	6
159324021	F -14	14
159690021	E -78	12
159706021	Sp -E-77	23
159708021	Sp -E-77	23
159805001	H -19-6	18
159907001	F -16	14
159998021	D -12	8
180018121	C -24	4
180322021	E -70	12
180885001	F -2-1	14
180886001	F -2-2	14
180891001	F -1-1	14
180892001	F -1-2	14
181916121	C -7	4
181995021	F -13	14
183388001	F -17-1	14
183389001	F -17-2	14
183390001	F -17-3	14
183493021	E -57	12
	E -71	12
183496221	G -1	16
183658229	Z -23-1-1	22
183850021	G -30	16
213765021	E -37-8	10

brother.

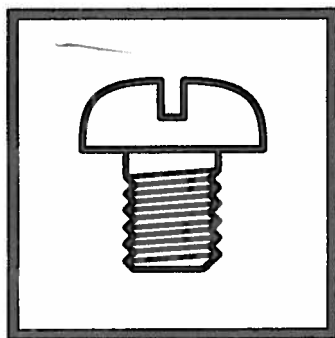

パーツブック  
PARTS BOOK  
TEILEKATALOG  
LIVRE DES PIECES  
LIBRO DE REFERENCIA DE PIEZAS

**ブラザー工業株式会社**  
BROTHER INDUSTRIES, LTD.

〒467 名古屋市瑞穂区河岸1丁目1番1号 TEL(052)824-2392

Printed in Japan / Gedruckt in Japan / Imprime au Japon / Impreso en Japon

877-101  
S95101-222  
1996.04 ①