

PARTS BOOK
FOR
BROTHER DB2-B757

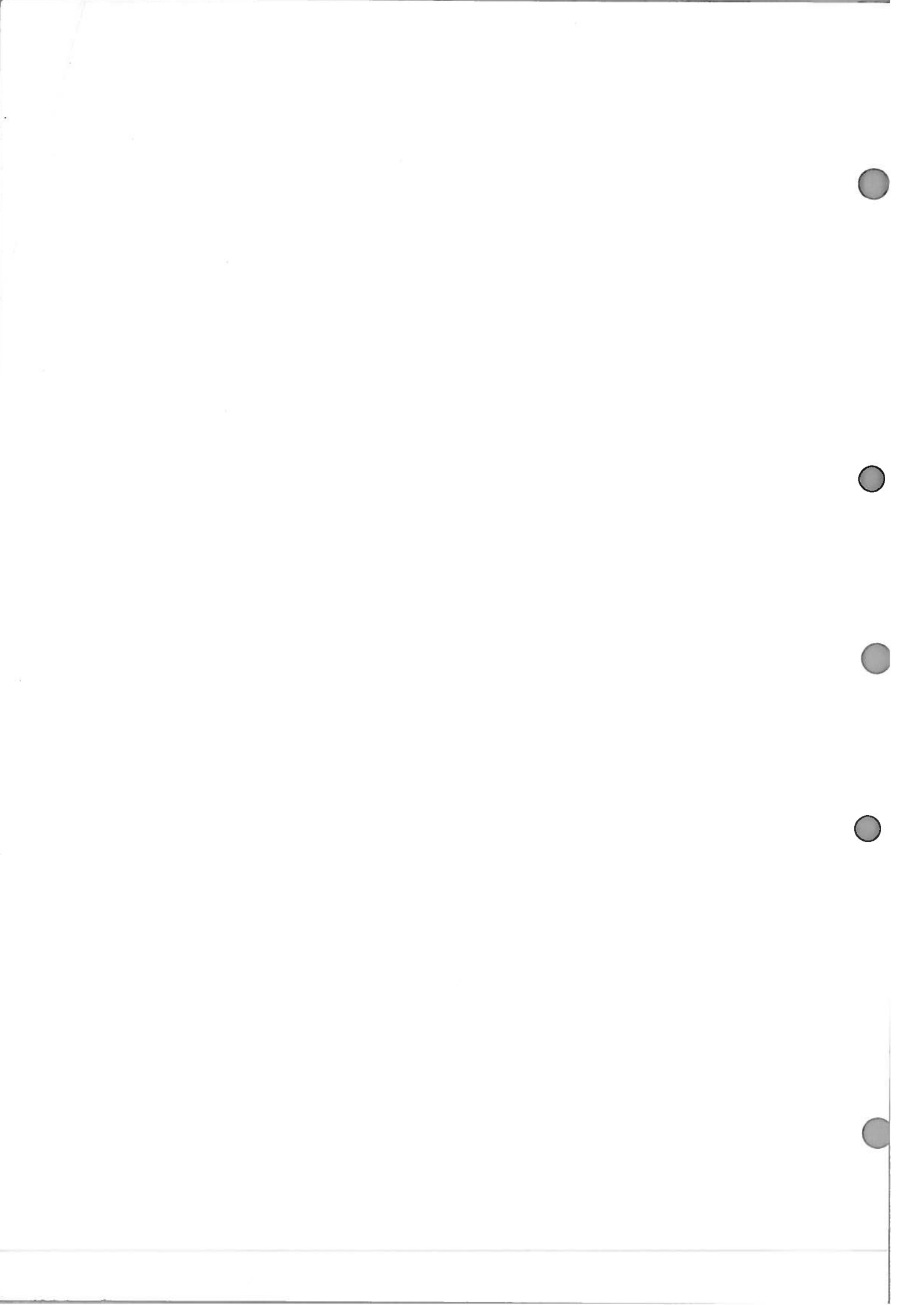



High Speed Lock Stitcher (with Thread Trimmer)



BROTHER INDUSTRIES, LTD.
NAGOYA, JAPAN





Notes for using this parts book

1. If the symbol  is found in the "Parts No." column or the "Assembly No." column, refer to the different parts list on page 14.
2. The symbol  in the "Parts No." column indicates that the parts is not available for supply. If, however, there is a number in the "Assembly No." column, the parts can be ordered as an assembly. Please, therefore, order by using the Assembly No..
3. This book was prepared based on information available in March, 1979.
4. Parts are subject to changes in design without prior notice.

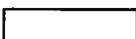

Anmerkungen zum Gebrauch dieses Stücklistebuches

1. Dieses Zeichen  in der Spalte "Parts No. (Teilnummer)" oder "Assembly No. (Gerätesatznummer)" verweist auf die Gesonderte Stückliste auf Seite 14.
2. Dieses Zeichen  in der Spalte "Teilnummer" bedeutet, daß dieser Teil nicht lieferbar ist. Wenn jedoch in der Spalte "Gerätesatznummer" eine Nummer steht, kann dieser Teil als ein Geräteteilsatz bestellt werden. Bestellen Sie daher bitte mit dieser Gerätesatznummer.
3. Dieses Buch basiert auf den Informationen vom März, 1979.
4. Modelländerungen sind vorbehalten.

Notes sur l'utilisation de ce manuel de pièces détachées

1. Si le symbole  se trouve dans la colonne "Parts No. (N° de pièce)" ou dans la colonne "Assembly No. (N° jeu de pces)", veuillez vous référer à la liste de pièces annexe page 14.
2. Le symbole  dans la colonne "N° de pièce" signifie que la pièce ne peut être fournie. Si, dans la colonne "N° jeu de pces", il y a un numéro de nomenclature, la pièce peut être commandée comme faisant partie d'un jeu de pièces. Donc, pour toute commande, veuillez spécifier le n° du pièces.
3. Ce manuel a été fait d'après les renseignements valables au mois de Mars, 1979.
4. Les pièces peuvent être sujettes à des modifications sans préavis.

Notas para usar este Libro de Piezas

1. De haber un símbolo  junto al "Parts No. (Número de Pieza)" o en la columna del "Assembly No. (Número de Juego)", habrá que mirar la lista de piezas separada de la página 14.
2. El símbolo , que se encuentra en la columna del "Número de Pieza", quiere decir que no se dispone de dicha pieza sola. Cuando, empero, hay un número en la columna del "Numero de Juego", se podrá ordenar la pieza con todo el juego. Por lo tanto, será mejor hacer el pedido recurriendo al número del juego respectivo.
3. Este libro ha sido compilado basándose en los datos de que se disponía en Marzo de 1979.
4. Las piezas quedan sujetas a cambios de diseño sin aviso previo.

CONTENTS

A. Machine Body	1
B. Upper Shaft and Needle Bar Mechanism.....	2
C. Lower Shaft and Feed Mechanism.....	3
D. Feed Mechanism	4
E. Presser Foot and Knee Lifter Mechanism.....	5
F. Lubrication	6
G. Thread Trimmer and Tension Releaser (-100, -200, -400, -500).....	7
H. Synchronizer (-100, -200, -400, -500).....	8
J. Thread Wiper and Reverse Switch Mechanism (-200, -400, -500).....	9
K. Reverse Mechanism (-400, -500).....	10
L. Control Box Mechanism (-500)	11
M. Presser Lifter Mechanism (-500).....	12
Z. Accessories	13
DIFFERENT PARTS LIST	14
INDEX.....	26

A. Machine Body

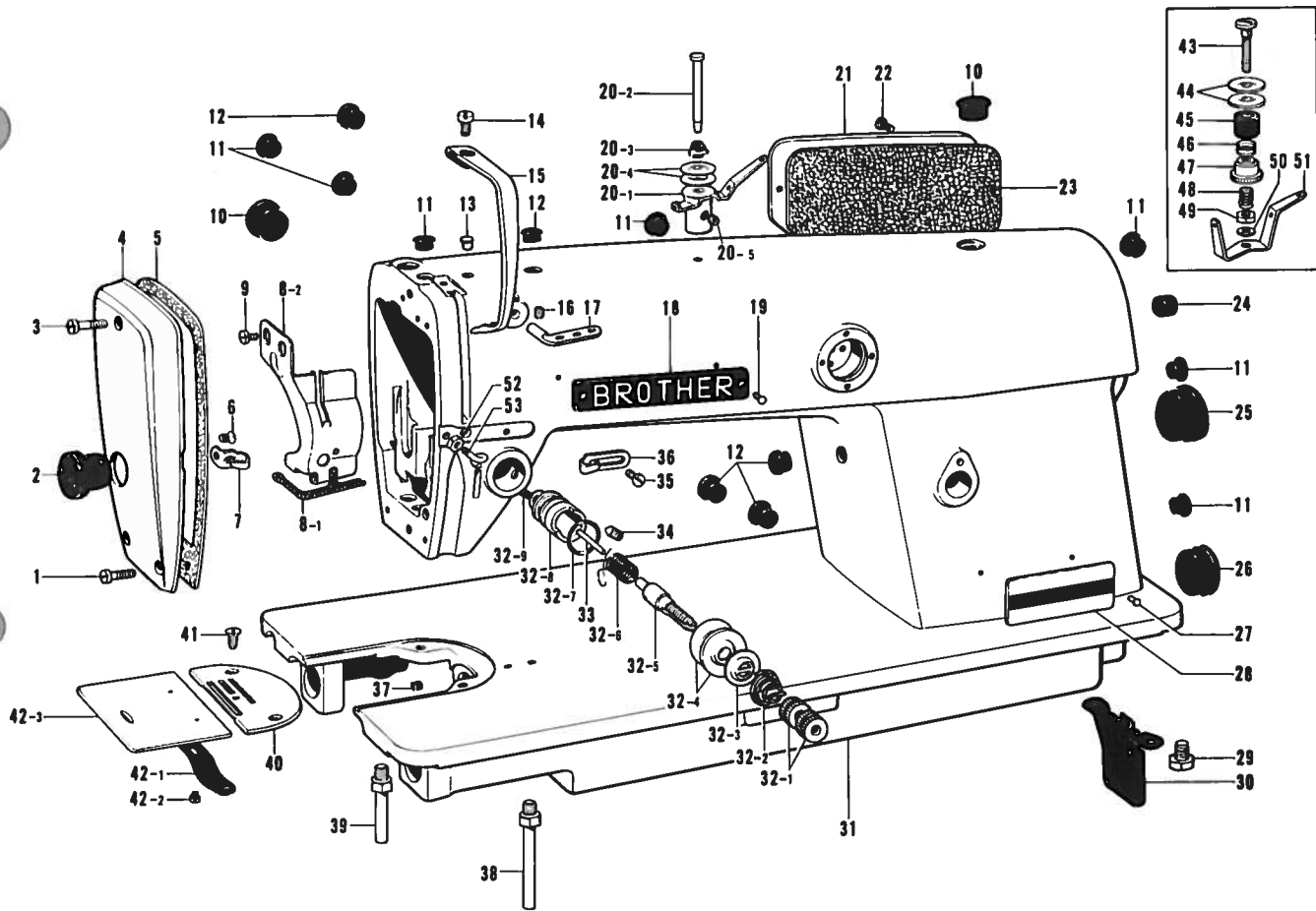

Ref. No.	Name of Parts	Q'ty	Parts No.	Assembly No.	Ref. No.	Name of Parts	Q'ty	Parts No.	Assembly No.
A-1	Screw	2	009671-0-13		A-30	Pump Cover	1	118672-0-01	
A-2	Oil Cap	1			A-31	Arm Bed	1		
A-3	Screw	1	009671-8-13		A-32-1	Nut	2	100136-0-01	A-32 Tension Regulator Assembly
A-4	Face Plate	1			A-32-2	Tension Spring	1		
A-5	Packing	1	109195-0-01		A-32-3	Tension Disc Washer	1	100134-0-01	
A-6	Screw	1			A-32-4	Tension Disc	2	145446-0-01	
A-7	Face Plate Thread Guide	1			A-32-5	Tension Stud	1	100398-0-01	
A-8-1	Wick	1	148302-0-01	A-8 Oil Stopper Plate Assembly	A-32-6	Thread Take-up Spring	1		
A-8-2	Oil Stopper Plate	1			A-32-7	Packing	1	114294-0-01	
A-9	Screw	2	009670-5-12		A-32-8	Upper Tension Regulator Bracket	1	144741-0-01	
A-10	Oil Cap	2	104449-0-01		A-32-9	Screw	1	100402-0-04	
A-11	Oil Cap	7	104450-0-01		A-33	Tension Release Pin	1		
A-12	Oil Cap	5	104821-0-01		A-34	Screw	1	103950-0-02	
A-13	Oil Cap	1	111865-0-01		A-35	Screw	1	009670-6-14	
A-14	Screw	1	009680-7-13		A-36	Arm Thread Guide	1	113316-0-01	
A-15	Thread Take-up Cover	1	140885-0-01		A-37	Oil Cap	1		
A-16	Screw	1	151602-0-02		A-38	Bed Leg L	1	104829-1-01	
A-17	Thread Retainer	1	114931-0-01		A-39	Bed Leg S	1	104830-1-01	
A-18	Name Plate BROTHER	1			A-40	Needle Plate	1		
A-19	Screw	2	124918-0-01		A-41	Screw	2	100032-0-03	
A-20-1	Pretension	1		A-20 Pretension Assembly	A-42-1	Slide Plate Spring	1	114561-0-01	A-42 Slide Plate Assembly 180018-0-01
A-20-2	Pretension Stud	1			A-42-2	Screw	2	122771-0-01	
A-20-3	Spring	1	144505-0-00		A-42-3	Slide Plate	1		
A-20-4	Thread Guide Disc	2	144504-0-01		A-43	Pre-Tension Stud	1	153111-0-01	
A-20-5	Screw	1	102716-0-03		A-44	Thread Guide Disc	2	144504-0-01	
A-21	Rear Cover	1			A-45	Pre-Tension Disc Washer	1	146206-0-01	
A-22	Screw	4	009670-8-12		A-46	Pre-Tension Spring	1	146058-0-01	
A-23	Packing	1	118778-0-01	A-47	Pre-Tension Nut	1	146059-0-01		
A-24	Oil Cap	2	104832-0-01	A-48	Spring	1	146060-0-00		
A-25	Oil Cap	1	118675-0-01	A-49	Nut	1	105234-0-01		
A-26	Oil Cap	1	108520-0-01	A-50	Washer	1	025680-2-34		
A-27	Model Plate Pin	2		A-51	Thread Guide Plate	1	146055-0-01		
A-28	Model Plate	1		A-52	Nut	1	021660-1-02		
A-29	Bolt	2	140704-0-01	A-53	Arm Thread Guide L	1	145524-0-01		

★Parts A-43~A-53 are for -100-200-400 and -500 type specification.

B. Upper Shaft and Needle Bar Mechanism

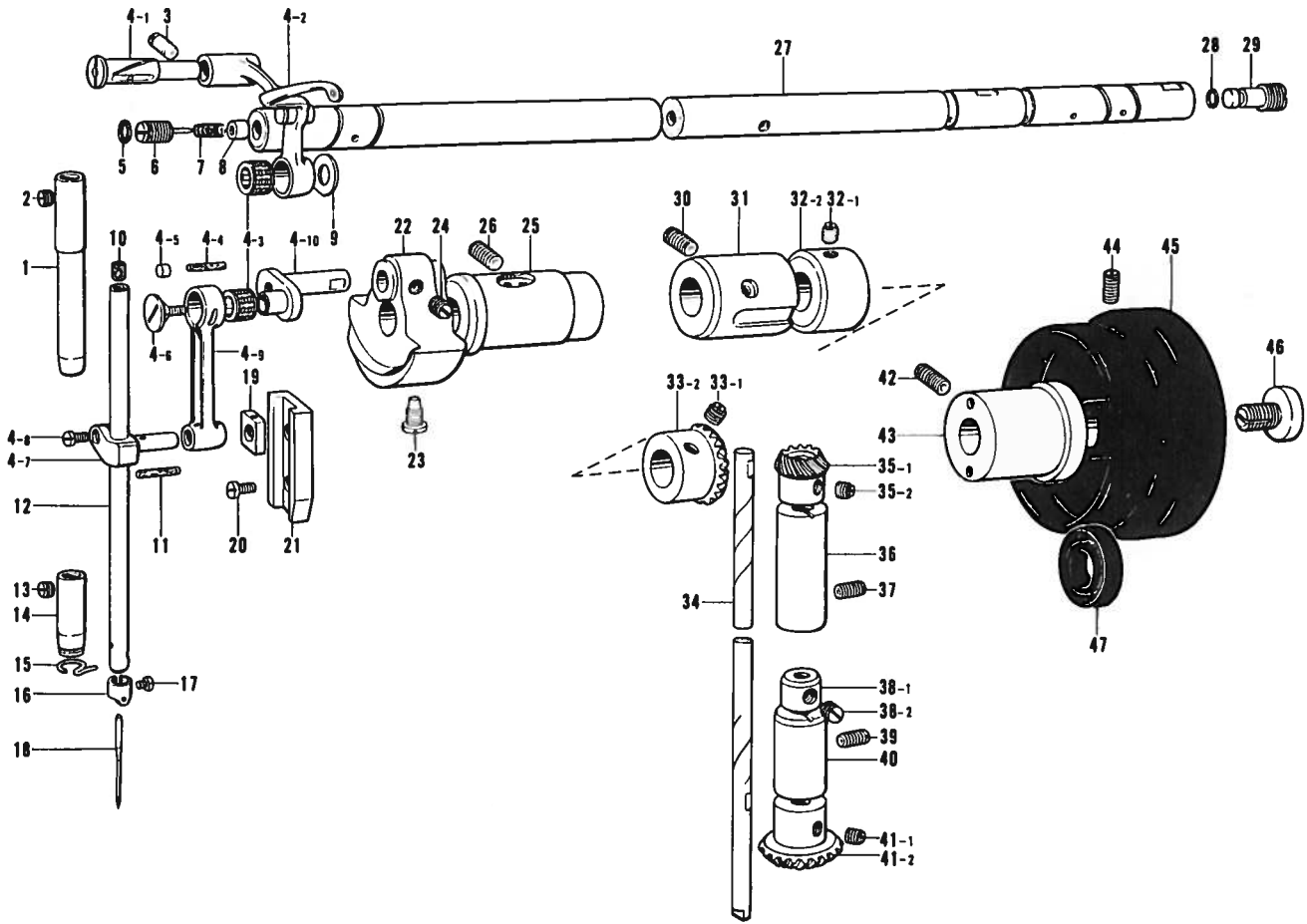

Ref. No.	Name of Parts	Q'ty	Parts No.	Assembly No.	Ref. No.	Name of Parts	Q'ty	Parts No.	Assembly No.
B-1	Needle Bar Bushing Upper	1	117242-0-01		B-28	Packing	1	081002-6-70	
B-2	Screw	1	100260-0-01		B-29	Oil Screw Right for Upper Shaft	1	104555-0-01	
B-3	Screw	1	013761-4-10		B-30	Screw	1	013761-4-10	
B-4-1	Stud	1	111468-0-01	B-4 Thread Take-up Lever Assembly	B-31	Upper Shaft Bushing Inter Mediate	1	140726-0-00	
B-4-2	Thread Take-up Lever	1			B-32-1	Screw	2	151604-0-01	B-32 Collar 181994-0-01
B-4-3	Needle Roller Bearing	2			B-32-2	Collar	1		
B-4-4	Felt	1	145624-0-00		B-33-1	Screw	2	100251-0-01	B-33 Upper Shaft Gear Assembly 180022-0-01
B-4-5	Cap	1			B-33-2	Upper Shaft Gear	1		
B-4-6	Screw	1	145465-0-01		B-34	Vertical Shaft	1	144868-0-01	B-35 Vertical Shaft Gear Assembly 180957-0-01
B-4-7	Needle Bar Clamp	1	111237-0-01		B-35-1	Vertical Shaft Gear	1		
B-4-8	Screw	1	140004-0-01		B-35-2	Screw	2	100251-0-01	
B-4-9	Needle Bar Connector	1			B-36	Vertical Shaft Upper Bushing	1	142708-0-00	
B-4-10	Needle Bar Crank	1			B-37	Screw	1	013760-6-10	
B-5	Packing	1	118770-0-01	B-38-1	Collar	1		B-38 Collar 118759-0-01	
B-6	Oil Adjusting Screw for Upper Shaft	1	140412-0-01	B-38-2	Screw	2	101706-0-01		
B-7	Spring	1	116799-0-01	B-39	Screw	1	013761-4-10		
B-8	Oil Bushing	1	140357-0-01	B-40	Vertical Shaft Lower Bushing	1	142709-0-00		
B-9	Washer	1	110367-0-01	B-41-1	Screw	3	100251-0-01	B-41 Vertical Shaft Gear Assembly 180959-0-01	
B-10	Needle Bar Cap	1	111863-0-01	B-41-2	Vertical Shaft Lower Gear	1			
B-11	Wick	1	108809-0-01	B-42	Screw	1	013760-6-10		
B-12	Needle Bar	1		B-43	Upper Shaft Bushing R	1	146331-0-01		
B-13	Screw	1	100260-0-01	B-44	Screw	2	013761-4-10		
B-14	Needle Bar Bushing Lower	1		B-45	Pulley	1			
B-15	Thread Guide Under	1	100573-0-01	B-46	Screw	1	104478-0-01		
B-16	Needle Bar Thread Guide	1		B-47	Oil Seal	1	101487-0-01		
B-17	Screw	1	140553-0-01						
B-18	Needle	1							
B-19	Needle Bar Guide Slide Block	1	102630-0-01						
B-20	Screw	2	009670-6-12						
B-21	Needle Bar Guide	1	102631-0-01						
B-22	Thread Take-up Crank	1							
B-23	Screw	1	104464-0-01						
B-24	Screw	2	100251-0-01						
B-25	Upper Shaft Bushing Left	1	111459-0-01						
B-26	Screw	1	013761-4-10						
B-27	Upper Shaft	1	118821-0-01						

C. Lower Shaft and Feed Mechanism

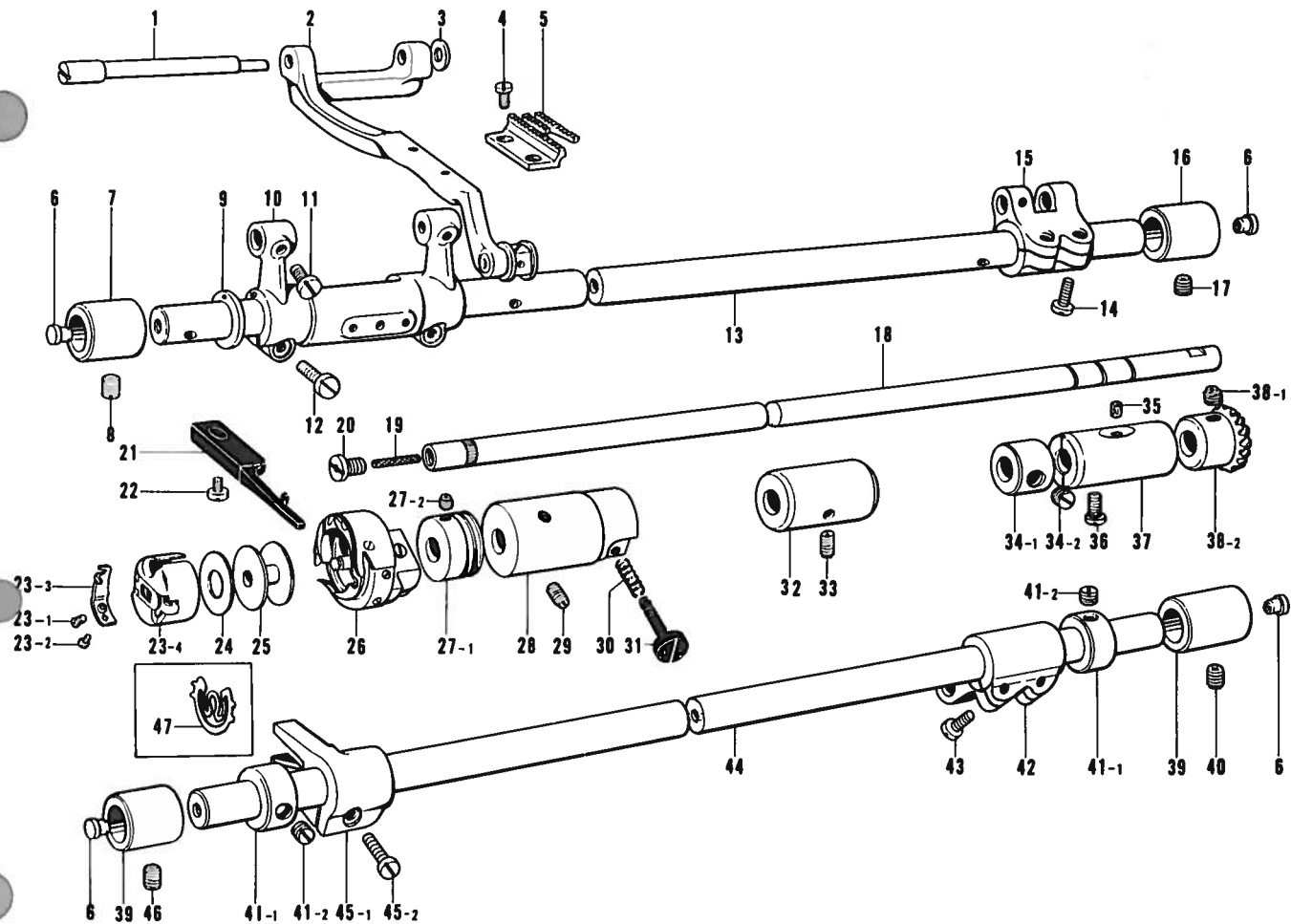

Ref. No.	Name of Parts	Qty	Parts No.	Assembly No.	Ref. No.	Name of Parts	Qty	Parts No.	Assembly No.
C-1	Feed Bar Shaft	1	116917-0-01		C-29	Screw	1	151603-0-02	
C-2	Feed Bed	1	118845-0-01		C-30	Spring	1	116794-0-01	
C-3	Ring	1	115663-0-01		C-31	Screw	1	145534-0-01	
C-4	Screw	2	100080-0-03		C-32	Lower Shaft Bushing Middle	1	118762-0-00	
C-5	Feed Dog	1			C-33	Screw	1	151607-0-01	
C-6	Oil Cap	4	111865-0-01		C-34-1	Collar	1		C-34
C-7	Feed Shaft Bushing Small	1	116766-0-01		C-34-2	Screw	2	101706-0-03	Collar 181995-0-01
C-8	Screw	1	101706-0-01		C-35	Felt	1	107155-0-01	
C-9	Thrust Ring	1	116920-0-01		C-36	Screw	1	121007-0-01	
C-10	Feed Bar Arm	1	145510-0-00		C-37	Lower Shaft Bushing Right	1	104520-0-00	
C-11	Screw	2	104908-0-01		C-38-1	Screw	2	100251-0-01	C-38
C-12	Screw	2	009681-2-12		C-38-2	Lower Shaft Gear	1		Lower Shaft Gear Assembly 180960-0-01
C-13	Feed Rock Shaft	1	142573-0-01		C-39	Feed Shaft Bushing Small	2	116766-0-01	
C-14	Screw	2	009711-2-12		C-40	Screw	1	100251-0-01	
C-15	Feed Rock Shaft Arm	1	148286-0-01		C-41-1	Collar	2		C-41
C-16	Feed Shaft Bushing Left	1	116919-0-01		C-41-2	Screw	4	101706-0-01	Collar Assembly 180321-0-01
C-17	Screw	1	101706-0-01		C-42	Feed Rock Shaft Arm	1	116768-0-01	
C-18	Lower Shaft	1			C-43	Screw	2	009681-2-12	
C-19	Felt	1			C-44	Feed Lifting Rock Shaft	1	142572-0-01	
C-20	Screw	1	109173-0-01		C-45-1	Feed Lifting Arm	1		C-45
C-21	Bobbin Case Holder Position Bracket	1	140757-0-01		C-45-2	Screw	1	009681-4-12	Feed Lifting Arm Assembly 180322-0-01
C-22	Screw	1			C-46	Screw	1	101706-0-01	
C-23-1	Spring Adjusting Screw	1	181937-0-01	C-23 Bobbin Case Assembly	C-47	Bobbin Presser Spring	1		
C-23-2	Spring Set Screw	1	181938-0-01						
C-23-3	Lower Thread Adjusting Spring	1	181936-0-01						
C-23-4	Bobbin Case	1							
C-24	Bobbin Case Sheet	1							
C-25	Bobbin	1	146290-0-01						
C-26	Rotary Hook Assembly	1							
C-27-1	Oil Stopper	1		C-27 Oil Stopper Assembly					
C-27-2	Screw	2	151601-0-02						
C-28	Lower Shaft Bushing Left	1	118761-0-00						

D. Feed Mechanism

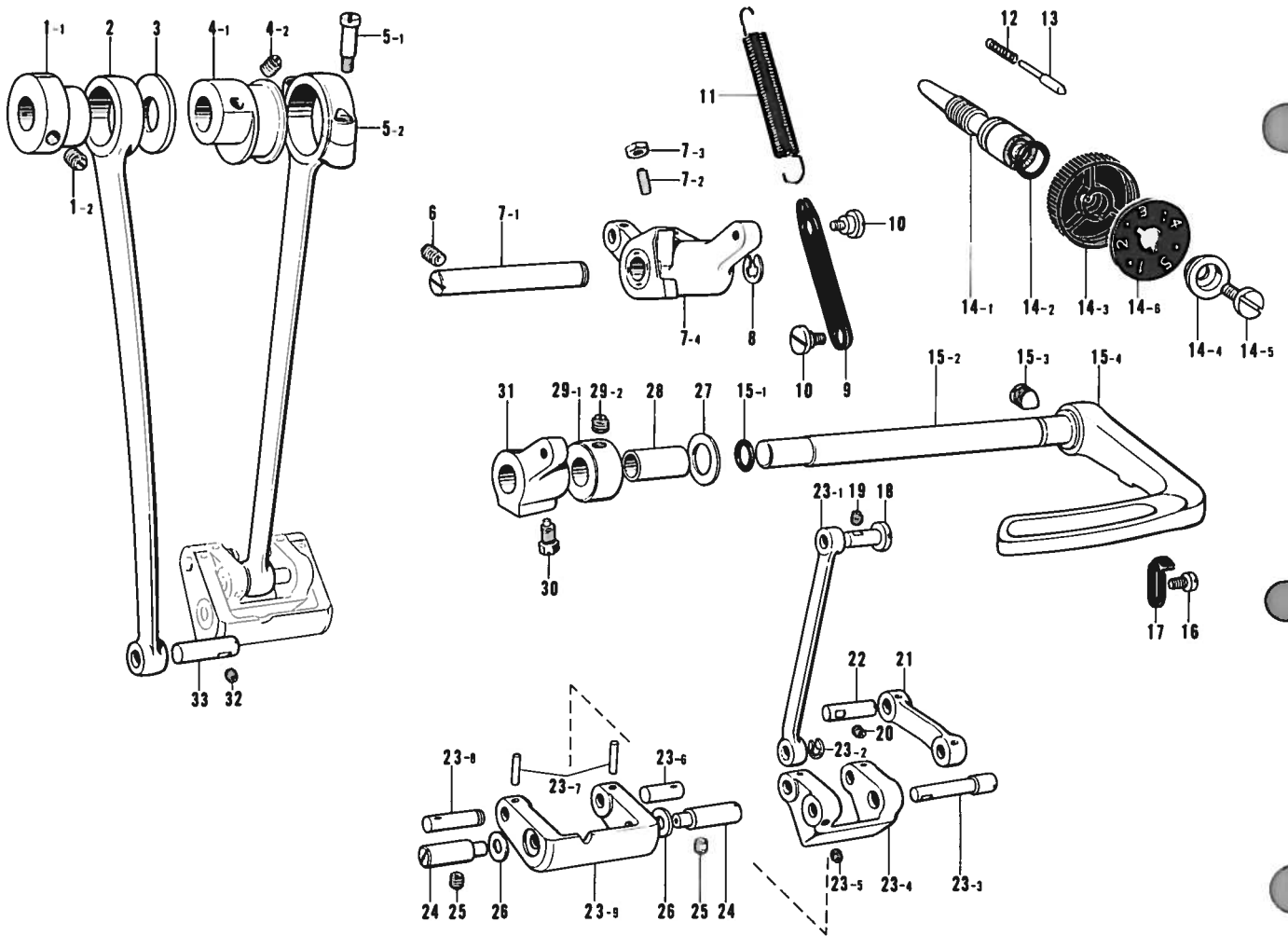

Ref. No.	Name of Parts	Q'ty	Parts No.	Assembly No.	Ref. No.	Name of Parts	Q'ty	Parts No.	Assembly No.
D- 1-1	Vertical Feed Eccentric Wheel	1		D-1	D-16	Screw	1	009680-7-14	
D- 1-2	Screw	2	151604-0-01	Eccentric Wheel 180791-0-01	D-17	Reverse Lever Stopper	1	118865-0-01	
D- 2	Vertical Feed Connecting Rod	1	118758-0-01		D-18	Pin	1	118713-0-01	
D- 3	Stopper	1	101482-0-01		D-19	Screw	1	151601-0-02	
D- 4-1	Eccentric Wheel	1		D-4	D-20	Screw	1	151601-0-02	
D- 4-2	Screw	2	151604-0-01	Eccentric Wheel	D-21	Lever Feed Connecting Rod	1	118736-0-01	
D- 5-1	Screw	2	144712-0-01	D-5	D-22	Feed Rock Shaft Arm Pin	1	118740-0-01	
D- 5-2	Crank Rod	1		Crank Rod 118725-0-01	D-23-1	Lever Regulator Connecting Rod	1	118730-0-01	
D- 6	Screw	1	151604-0-01		D-23-2	Stop Ring	1	048040-3-42	
D- 7-1	Feed Controller Shaft	1	118744-0-01	D-7	D-23-3	Stud	1	118737-0-01	
D- 7-2	Screw	1	151607-0-01	Feed Controller Assembly 153142-0-01	D-23-4	Lever Feed Link	1	118729-0-01	
D- 7-3	Nut	1	105234-0-01		D-23-5	Screw	1	151601-0-02	
D- 7-4	Feed Controller	1			D-23-6	Stud Small	1	118732-0-01	
D- 8	Stop Ring	1	048070-3-42		D-23-7	Pin	2	118733-0-01	
D- 9	Connecting Plate	1	118746-0-01		D-23-8	Stud Large	1	118731-0-01	
D-10	Screw	2	112072-0-01		D-23-9	Feed Regulator	1		
D-11	Spring	1			D-24	Feed Regulator Shaft	2	118734-0-01	
D-12	Spring	1	100328-0-01		D-25	Screw	2	151604-0-01	
D-13	Pin	1	100327-0-01		D-26	Washer	2	118735-0-01	
D-14-1	Length Control Screw	1	109151-1-01	D-14	D-27	Washer	1	025100-1-30	
D-14-2	Packing	1	108549-0-01	Length Control Assembly 181482-0-01	D-28	Collar	1	118748-0-01	
D-14-3	Length Control Dial	1	153168-0-01		D-29-1	Collar	1		D-29
D-14-4	Washer	1	142746-0-02		D-29-2	Screw	2	151604-0-01	Collar 118824-0-01
D-14-5	Screw	1	142747-0-02		D-30	Bolt	1	108749-0-01	
D-14-6	Feed Regulator Plate	1	151507-0-01		D-31	Feed Regulator Bracket	1	118747-0-01	
D-15-1	Packing	1	104564-0-01	D-15	D-32	Screw	1	151601-0-02	
D-15-2	Feed Controller Lever Shaft	1	118751-0-01	Reverse Lever Assembly	D-33	Feed Rock Shaft Arm Pin	1	109153-0-01	
D-15-3	Screw	1	015771-0-12						
D-15-4	Reverse Lever	1							

E. Presser Foot and Knee Lifter Mechanism

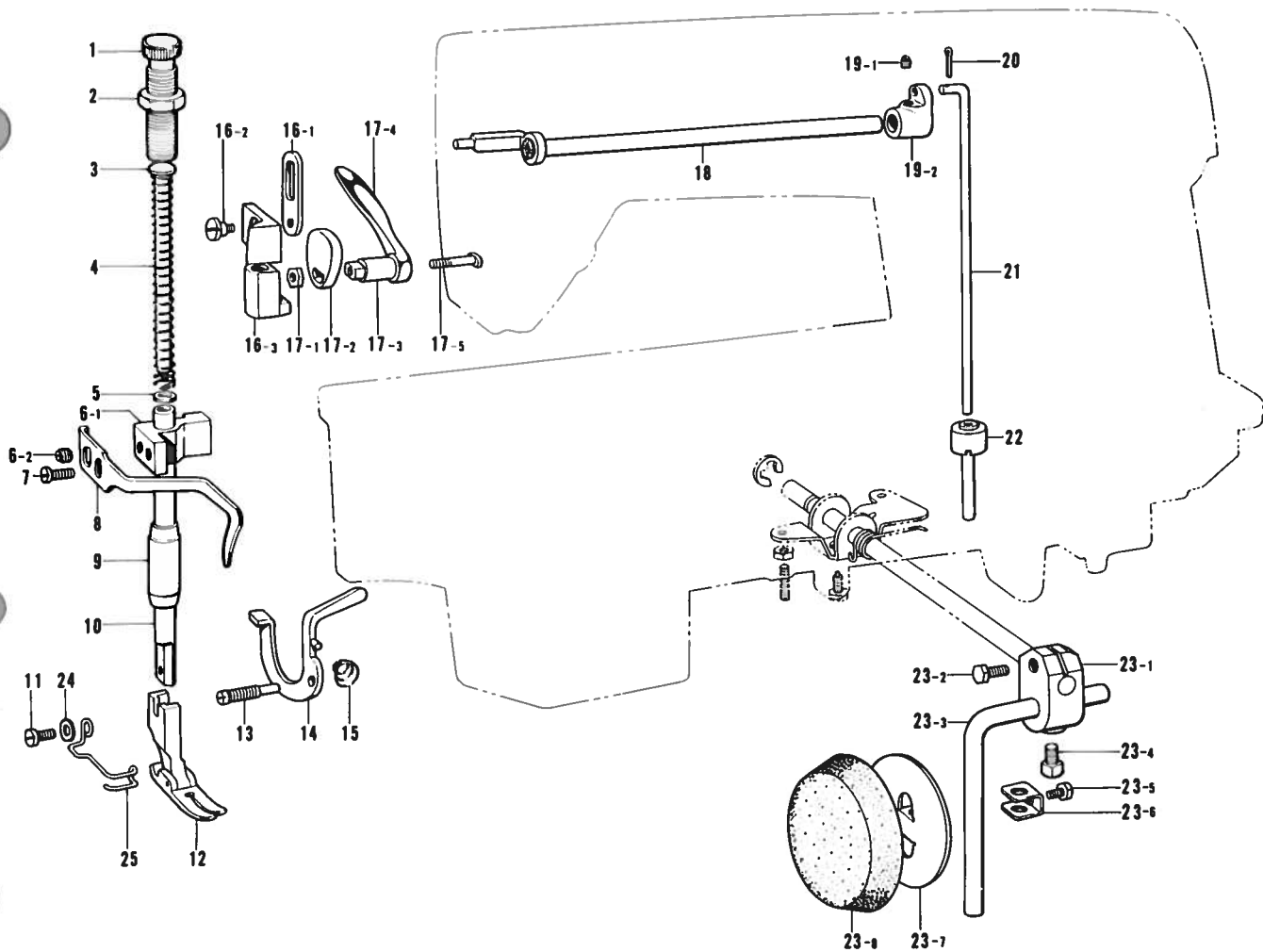

Ref. No.	Name of Parts	Q'ty	Parts No.	Assembly No.	Ref. No.	Name of Parts	Q'ty	Parts No.	Assembly No.
E- 1	Screw	1	141207-0-01		E-17-1	Nut	1	021680-2-02	E-17
E- 2	Nut	1	147846-0-01		E-17-2	Presser Bar Lifting Cam	1	142015-0-01	Presser Bar Lifting Lever Assembly
E- 3	Presser Spring Bar	1	141208-0-01		E-17-3	Presser Bar Lifting Shaft	1	142017-0-01	
E- 4	Spring	1	141728-0-01		E-17-4	Presser Bar Lifting Lever	1		142014-0-01
E- 5	Washer	1	140407-0-01		E-17-5	Screw	1	142018-0-01	
E- 6-1	Presser Bar Bracket	1		E-6 Presser Bar Assembly 180102-0-01	E-18	Knee Lifter Upper Crank Shaft	1	109145-0-01	
E- 6-2	Screw	1	151604-0-01			E-19-1	Screw	1	100251-0-01
E- 7	Screw	1	009680-7-13		E-19-2	Knee Lifter Crank Upper	1		
E- 8	Presser Bar Bracket Thread Guide	1	111469-0-01		E-20	Pin	1	045161-0-00	
E- 9	Presser Bar Bushing	1	111467-0-01		E-21	Knee Lifter Connecting Rod	1	141168-0-01	
E-10	Presser Bar	1	111466-0-01		E-22	Knee Lifter Complying Bar	1	145573-0-00	
E-11	Screw	1	001670-8-14		E-23-1	Knee Lifter Joint	1	146039-0-01	E-23 Knee Lifter Assembly 181427-0-01
E-12	Presser Foot	1			E-23-2	Bolt	1	017762-0-13	
E-13	Hinge Screw	1			E-23-3	Knee Lifter Bar	1	104619-0-02	
E-14	Tension Release Lever	1			E-23-4	Bolt	1	100463-0-01	
E-15	Tension Release Lever Spring	1			E-23-5	Bolt	1	110087-0-01	
E-16-1	Presser Bar Lifting Connector	1	109144-0-01	E-16 Presser Bar Lifting Assembly 181623-0-01	E-23-6	Knee Lifter Plate Stopper	1	114967-0-01	
E-16-2	Screw	1	100294-0-01			E-23-7	Knee Lifter Plate	1	
E-16-3	Presser Bar Lifting Bracket	1	100290-0-01		E-23-8	Knee Lifter Cover	1	140503-0-01	
					E-24	Washer	1		
					E-25	Finger Guard	1		

★Parts E-22-23 are for -100-200 and -400 type specification.

F. Lubrication

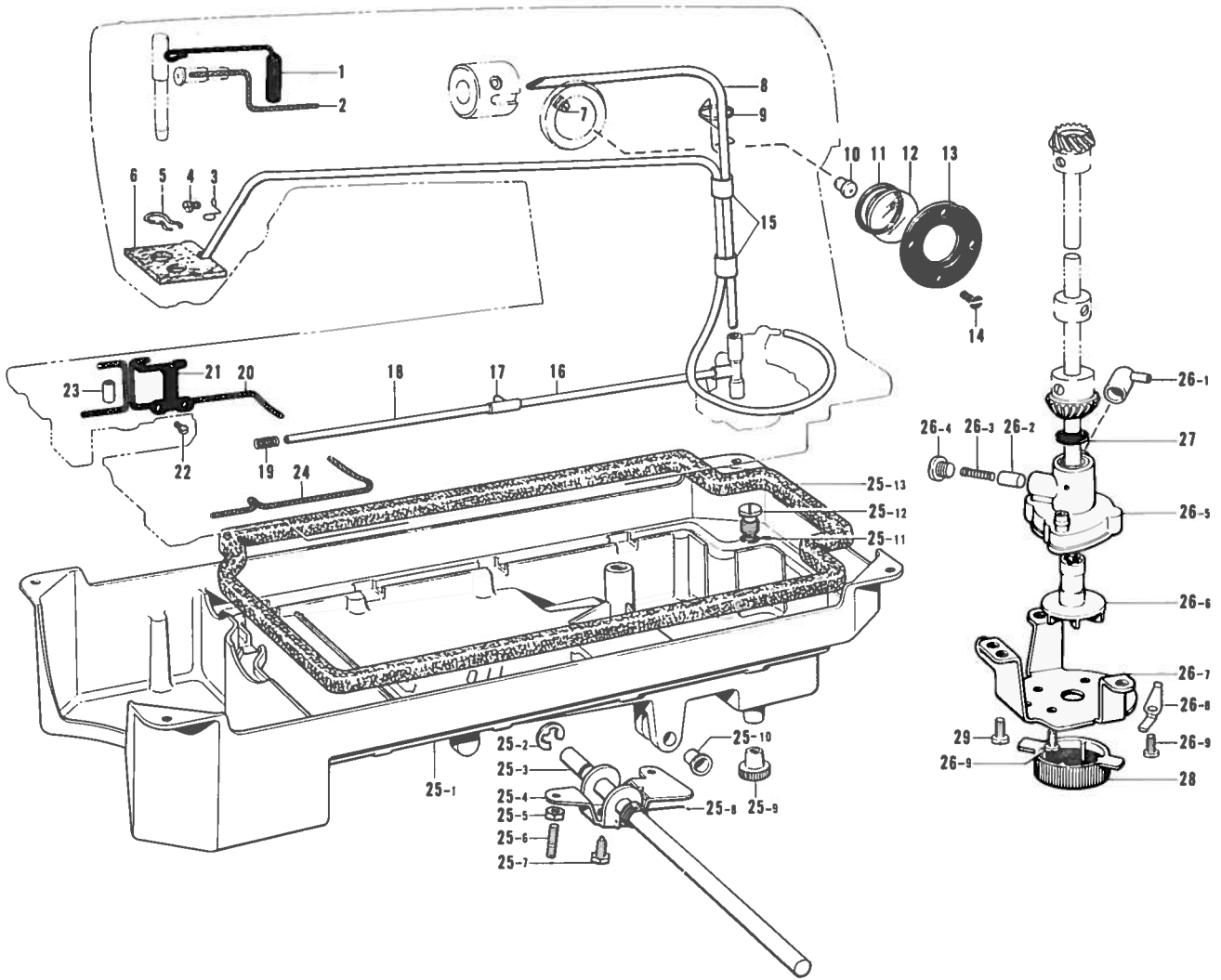

Ref. No.	Name of Parts	Q'ty	Parts No.	Assembly No.	Ref. No.	Name of Parts	Q'ty	Parts No.	Assembly No.
F- 1	Wick	1	108804-0-01		F-25- 4	Knee Lifter	1	146037-0-01	F-25 Oil Pan Assembly
F- 2	Wick	1	109405-0-01		F-25- 5	Nut	2	100022-0-04	
F- 3	Tube Stopper	1	148806-0-01		F-25- 6	Screw	2	104885-0-01	
F- 4	Screw	1	009670-5-12		F-25- 7	Bolt	1	146367-0-01	
F- 5	Felt Support	1	145737-0-01		F-25- 8	Spring	1		
F- 6	Dust Cover with Tube	1	145792-0-01		F-25- 9	Oil Cap	1	140480-0-01	
F- 7	Screw	1	151603-0-02		F-25-10	Knee Lifter Shaft Bushing	2	149578-0-00	
F- 8	Upper Oil Tube	1	146329-0-00		F-25-11	O Ring	1	081007-0-70	
F- 9	Tube Guard	1	146326-0-01		F-25-12	Screw	1	140518-0-01	
F-10	Oil Hole Bolt for Oil Gauge	1	143196-0-01		F-25-13	Packing	1	146040-0-01	
F-11	Packing	1	081014-6-70		F-26- 1	Tube Joint	1	144878-0-01	F-26 Pump Body Assembly 181476-1-01
F-12	Oil Gauge Window	1	104547-0-01		F-26- 2	Plunger	1	144875-0-01	
F-13	Oil Gauge Flange	1	104546-0-01		F-26- 3	Spring	1	144876-0-01	
F-14	Screw	4	102538-0-02		F-26- 4	Screw	1	112467-0-02	
F-15	Vinyl Tube	2	118996-0-00		F-26- 5	Pump Body	1	148848-0-01	
F-16	Oil Tube	1	146319-0-01		F-26- 6	Pump Propeller	1	148849-0-01	
F-17	Tube Joint	1	146324-0-01		F-26- 7	Pump	1	144869-0-01	
F-18	Vinyl Tube	1	146323-0-00		F-26- 8	Spring	2	144874-0-01	
F-19	Spring	1	100328-0-01		F-26- 9	Screw	4	009670-8-12	
F-20	Wick	1	108801-0-01		F-27	Oil Stopper	1	146196-0-01	
F-21	Wick Supporter	1	109171-0-01		F-28	Pump Filter	1	144872-0-01	
F-22	Screw	2	009679-3-12		F-29	Screw	3	009680-7-13	
F-23	Vinyl Tube	1	104566-0-01						
F-24	Wick	1	108802-0-01						
F-25-1	Oil Pan	1		F-25					
F-25-2	Stop Ring	1	146293-0-01	Oil Pan Assembly					
F-25-3	Knee Lifter Shaft	1							

G. Thread Trimmer and Tension Releaser (-100, -200, -400, -500)

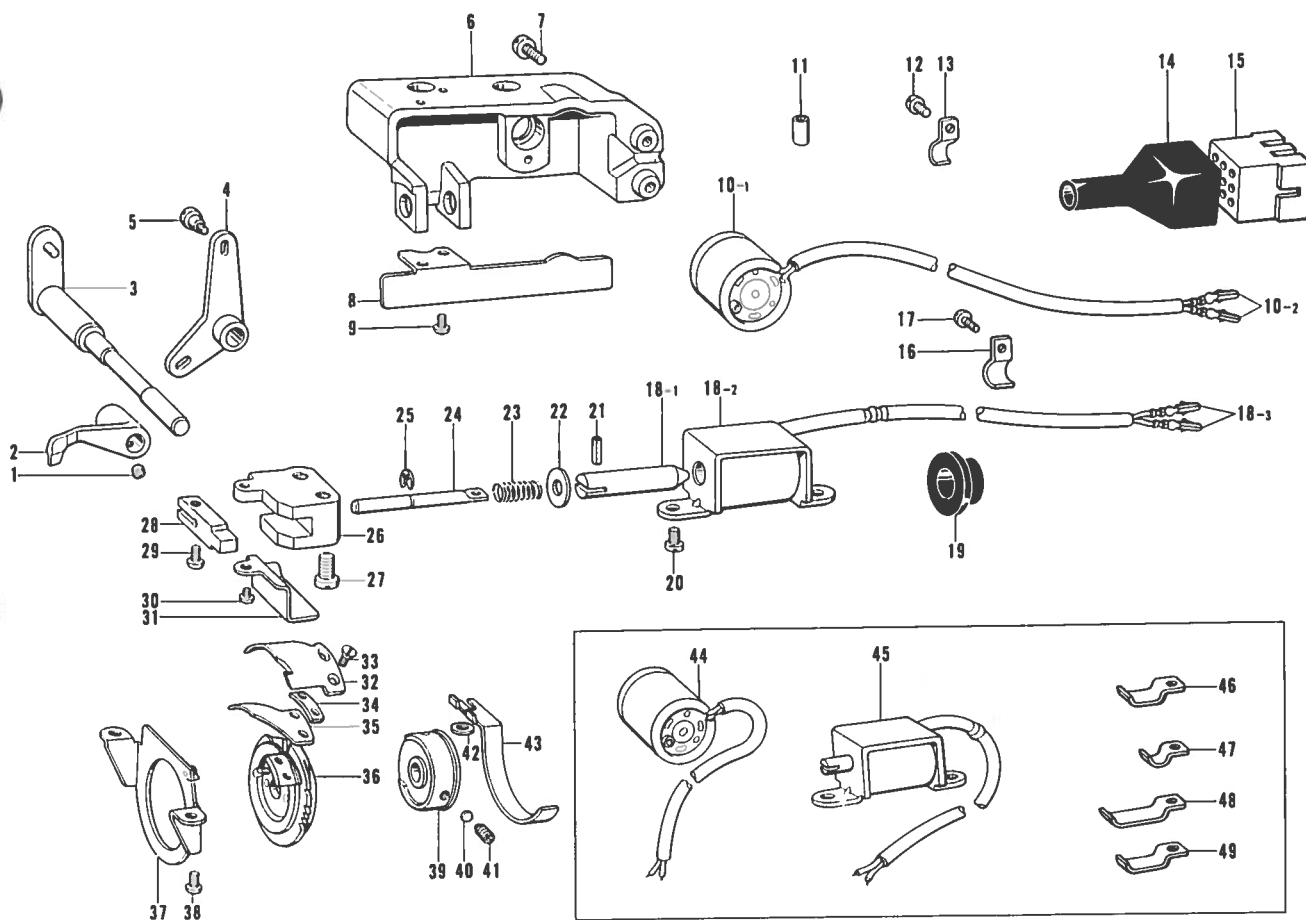

Ref. No.	Name of Parts	Q'ty	Parts No.	Assembly No.	Ref. No.	Name of Parts	Q'ty	Parts No.	Assembly No.
G-1	Screw	1	102716-0-03		G-23	Spring	1	145621-0-01	
G-2	Thread Release Lever	1	148327-0-01		G-24	Stud	1	145620-0-01	
G-3	Thread Release Stud	1	148339-0-01		G-25	Stop Ring	1	048030-3-42	
G-4	Thread Release Link	1	147106-0-01		G-26	Stopper Guide	1	145618-0-01	
G-5	Screw	1	120263-0-01		G-27	Screw	2	145619-0-01	
G-6	Solenoid Holder	1	147110-1-01		G-28	Stopper	1	145617-0-01	
G-7	Screw	2	009681-0-13		G-29	Screw	1	009660-7-12	
G-8	Solenoid Cover	1	148451-0-01		G-30	Screw	1	009679-3-12	
G-9	Screw	2			G-31	Oil Stopper Plate	1	145623-0-01	
G-10-1	Rotary Solenoid	1		G-10 Tension Release Solenoid Assembly	G-32	Movable Knife	1		
G-10-2	Terminal Pin	2	143549-0-00		G-33	Screw	2	141542-0-01	
G-11	Vinyl Tube	1	121823-0-01		G-34	Spacer	1		
G-12	Screw	2	009670-6-12		G-35	Lower Thread Finger	1	145610-1-01	
G-13	Supporter	2			G-36	Movable Knife Holder Assembly	1	145601-0-01	
G-14	Connector Cap	1			G-37	Holder Plate	1	145933-0-01	
G-15	Nylon Connector	1			G-38	Screw	2	009680-6-12	
G-16	Cord Holder	2	145595-0-01		G-39	Thread Trimming Clutch	1	149709-0-01	
G-17	Screw	2	009680-6-12		G-40	Washer	3	147697-0-01	
G-18-1	Plunger	1			G-41	Screw	3	014680-6-22	
G-18-2	Solenoid Coil	1		G-18 Thread Trimming Solenoid Assembly	G-42	Washer	1	025680-1-33	
G-18-3	Terminal Pin	2	143549-0-00		G-43	Movable Knife Cover	1	147946-0-01	
G-19	Bushing	1	146080-0-00		G-44	Rotary Solenoid	1		
G-20	Screw	2	009680-7-12		G-45	Thread Trimmer Solenoid	1		
G-21	Pin	1	047300-8-42		G-46	Tube Holder	2		
G-22	Washer	1	025040-3-35		G-47	Cord Holder	2		
					G-48	Cord Holder	1		
					G-49	Cord Holder	1		

H. Synchronizer (-100, -200, -400, -500)

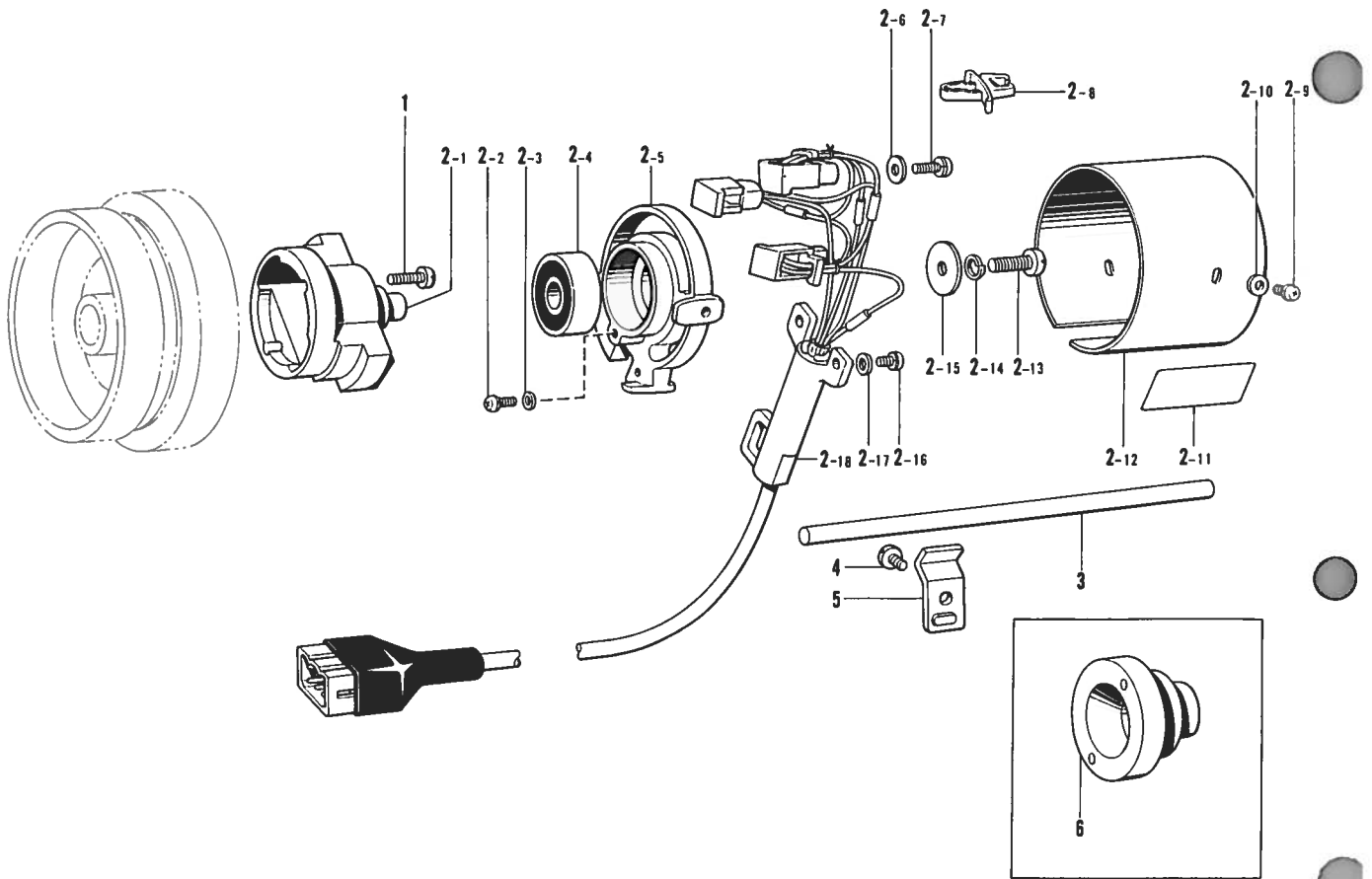

Ref. No.	Name of Parts	Q'ty	Parts No.	Assembly No.	Ref. No.	Name of Parts	Q'ty	Parts No.	Assembly No.
H-1	Screw	2	009781-4-12	H-2 Synchronizer Assembly	H-2-12	Synchronizer Cover	1	218941-0-01	H-2 Synchronizer Assembly
H-2-1	Magnet Stud	1			H-2-13	Screw	1	216880-0-01	
H-2-2	Screw	1	215083-0-01		H-2-14	Spring Washer	1	028060-2-43	
H-2-3	Washer	1	025030-3-35		H-2-15	Washer	1	025060-3-35	
H-2-4	Bearing	1			H-2-16	Screw	2	215080-0-01	
H-2-5	Hole IC Holder	1			H-2-17	Washer	2	025040-1-35	
H-2-6	Washer	3	025040-3-35		H-2-18	Hole IC with Cord	1	218953-0-01	
H-2-7	Screw	3	217093-0-01		H-3	Synchronizer Holder Bar	1		
H-2-8	Cord Holder	1			H-4	Screw	2	009711-4-12	
H-2-9	Screw	2	215080-0-01		H-5	Holder	1		
H-2-10	Washer	2	025040-1-35		H-6	Slip Ring Support	1		
H-2-11	Label	1							

J. Thread Wiper and Reverse Switch Mechanism (-200, -400, -500)

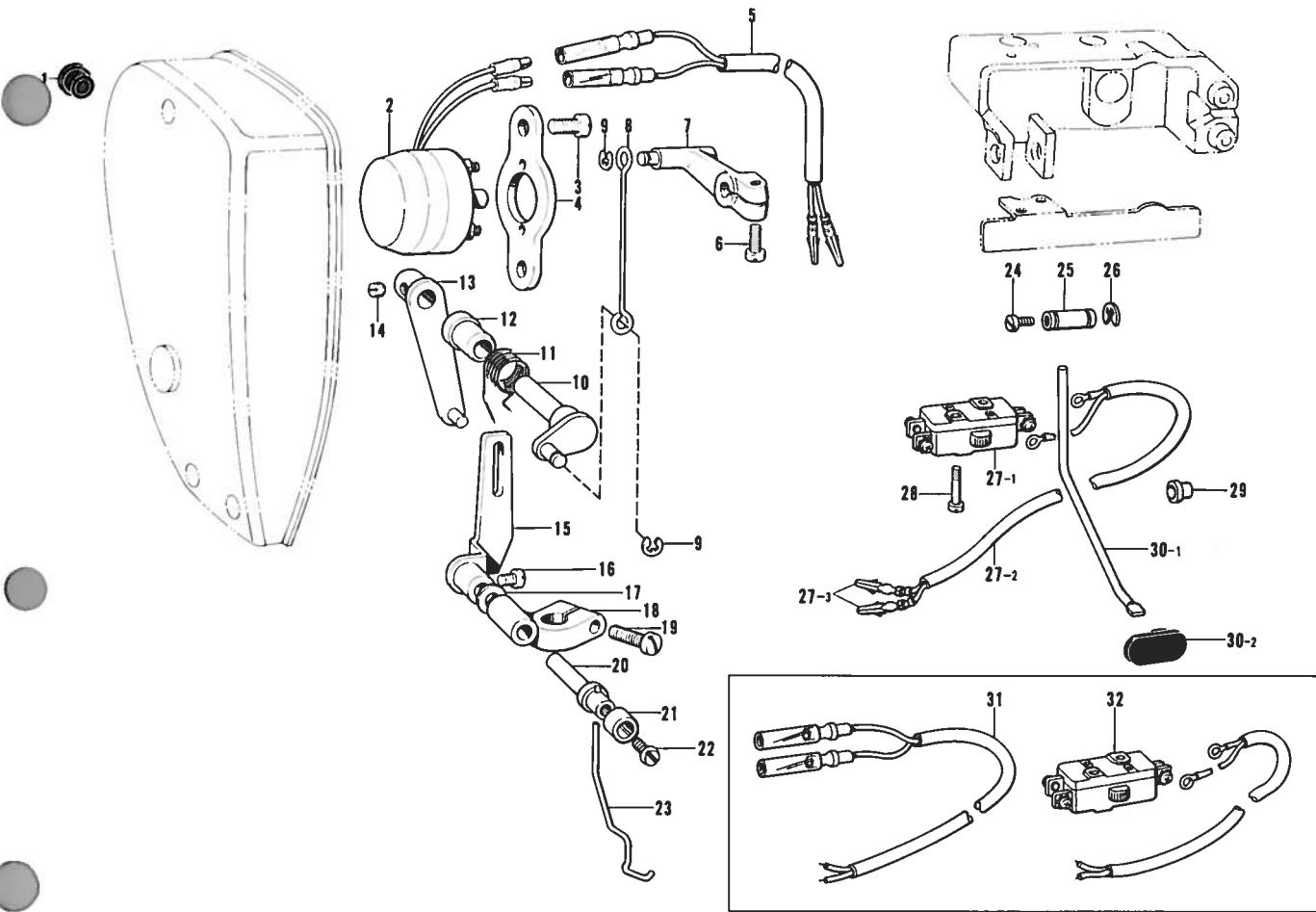

Ref. No.	Name of Parts	Q'ty	Parts No.	Assembly No.	Ref. No.	Name of Parts	Q'ty	Parts No.	Assembly No.
J-1	Bushing	1	146080-0-00		J-20	Thread Wiper Stud	1	146092-0-01	
J-2	Thread Wiper Solenoid	1	146082-0-00		J-21	Thread Wiper Stud Collar	1	146288-0-01	
J-3	Screw	2	009680-8-12		J-22	Screw	1	001670-5-14	
J-4	Solenoid Set Plate	1	146081-0-01		J-23	Thread Wiper	1	146094-0-01	
J-5	Cord	1			J-24	Screw	1	009681-4-14	
J-6	Screw	1	009671-0-13		J-25	Actuator Pin	1	146125-0-01	
J-7	Solenoid Link	1	146086-0-01		J-26	Stop Ring	2	048080-3-42	
J-8	Wire Link	1	146087-0-01		J-27-1	Micro Switch	1	140643-0-00	J-27 Switch
J-9	Stop Ring	2	048025-3-42		J-27-2	Cord	1	146122-0-00	
J-10	Thread Wiper Crank	1	146088-0-01		J-27-3	Terminal Pin	2	143549-0-00	
J-11	Spring	1	146089-0-01		J-28	Screw	2	146124-0-01	
J-12	Bushing	1	146079-0-01		J-29	Bushing	1	146080-0-00	
J-13	Thread Wiper Lever	1	146090-0-01		J-30-1	Actuator Bar	1	148461-0-01	J-30 Actuator Assembly 148460-0-01
J-14	Screw	2	102716-0-02		J-30-2	Actuator	1	146128-0-00	
J-15	Grooved Link	1	146091-0-01		J-31	Cord	1		
J-16	Screw	1	111443-0-01		J-32	Switch	1		
J-17	Washer	1	102707-0-02						
J-18	Thread Wiper Supporter	1	146093-0-01						
J-19	Screw	1	009681-4-14						

★Parts J-1~J-23 are for -200, -400 and -500 type specification, and Parts J-24~J-30 are for -400 and -500 one.

K. Reverse Mechanism (-400, -500)

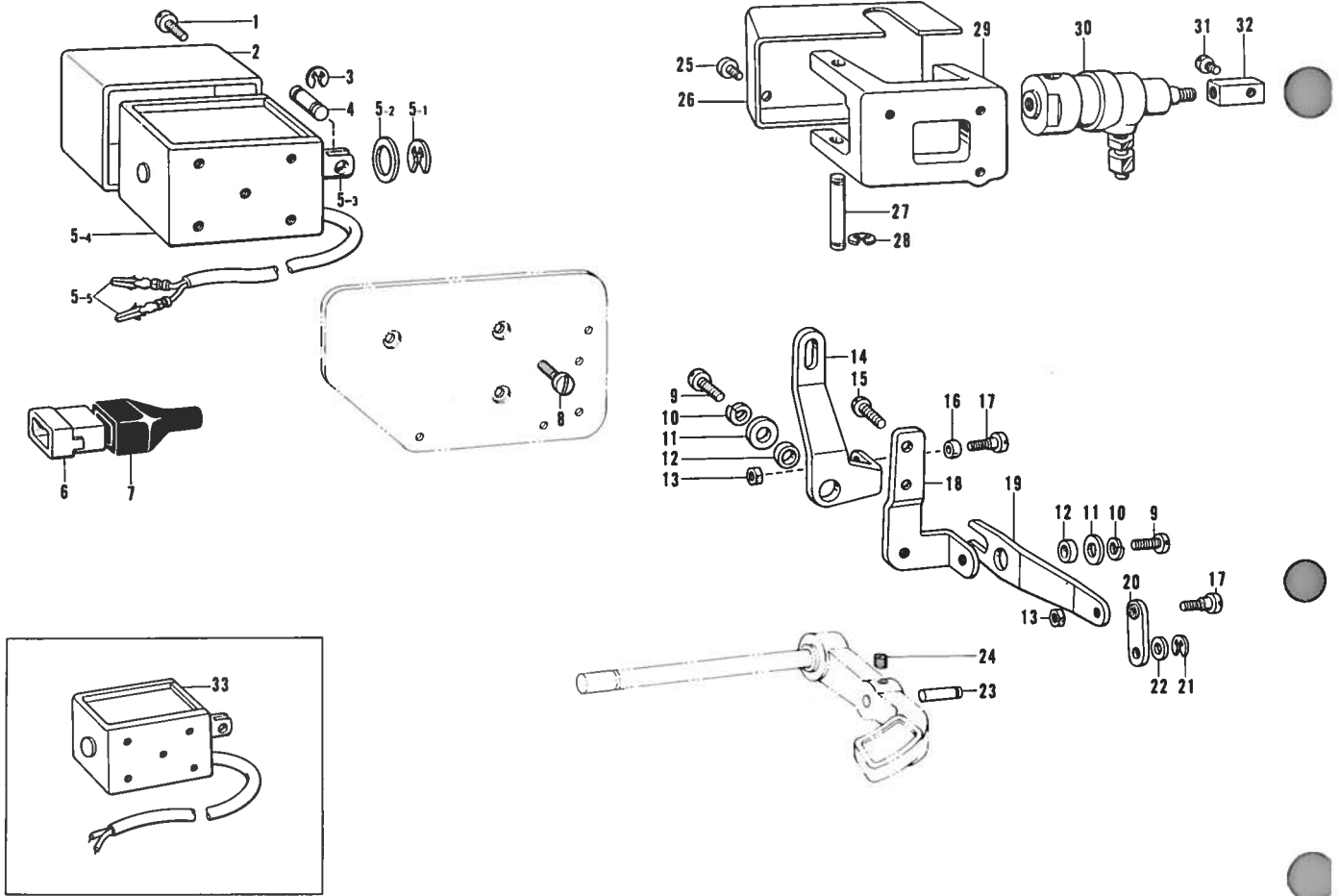

Ref. No.	Name of Parts	Q'ty	Parts No.	Assembly No.	Ref. No.	Name of Parts	Q'ty	Parts No.	Assembly No.
K-1	Screw	1	007501-2-02		K-16	Bushing	1	141331-0-01	
K-2	Solenoid Cover	1	148465-0-00		K-17	Screw	2	141494-0-01	
K-3	Stop Ring	2	048040-3-42		K-18	Solenoid Lever Bracket	1	148454-0-01	
K-4	Pin	1	147754-0-01		K-19	Reverse Link	1	148455-0-01	
K-5-1	Stop Ring	1	146103-0-01	K-5 Reverse Solenoid Assembly	K-20	Connecting Link	1	148467-0-01	
K-5-2	Rubber Stopper	1	146104-0-00		K-21	Stop Ring	1	048040-3-42	
K-5-3	Plunger	1			K-22	Washer	1	146115-0-00	
K-5-4	Solenoid	1			K-23	Pin	1	146114-0-01	
K-5-5	Terminal Pin	2	143549-0-00		K-24	Screw	1	013679-4-12	
K-6	6P Connector	1		K-25	Screw	2	009670-5-13		
K-7	Connector Cap	1		K-26	Cover	1	146156-0-01		
K-8	Screw	3	007500-8-12	K-27	Cylinder Supporter Shaft	1	146148-0-01		
K-9	Screw	2	009761-4-12	K-28	Stop Ring	2	048040-3-42		
K-10	Washer	2	028060-2-42	K-29	Cylinder Holder	1	148853-0-01		
K-11	Washer	2	141343-0-02	K-30	Reverse Cylinder	1	146149-0-01		
K-12	Collar	2	148456-0-01	K-31	Screw	1	141598-0-01		
K-13	Nut	2	150553-0-01	K-32	Piston Rod Connector	1	148854-0-01		
K-14	Solenoid Lever	1	148453-0-01	K-33	Reverse Solenoid	1			
K-15	Bolt	2	146360-0-02						

★Parts K-1~K-24 are for -400 type specification, and Parts K-8~K-32 are for -500 one.

L. Control Box Mechanism (-500)

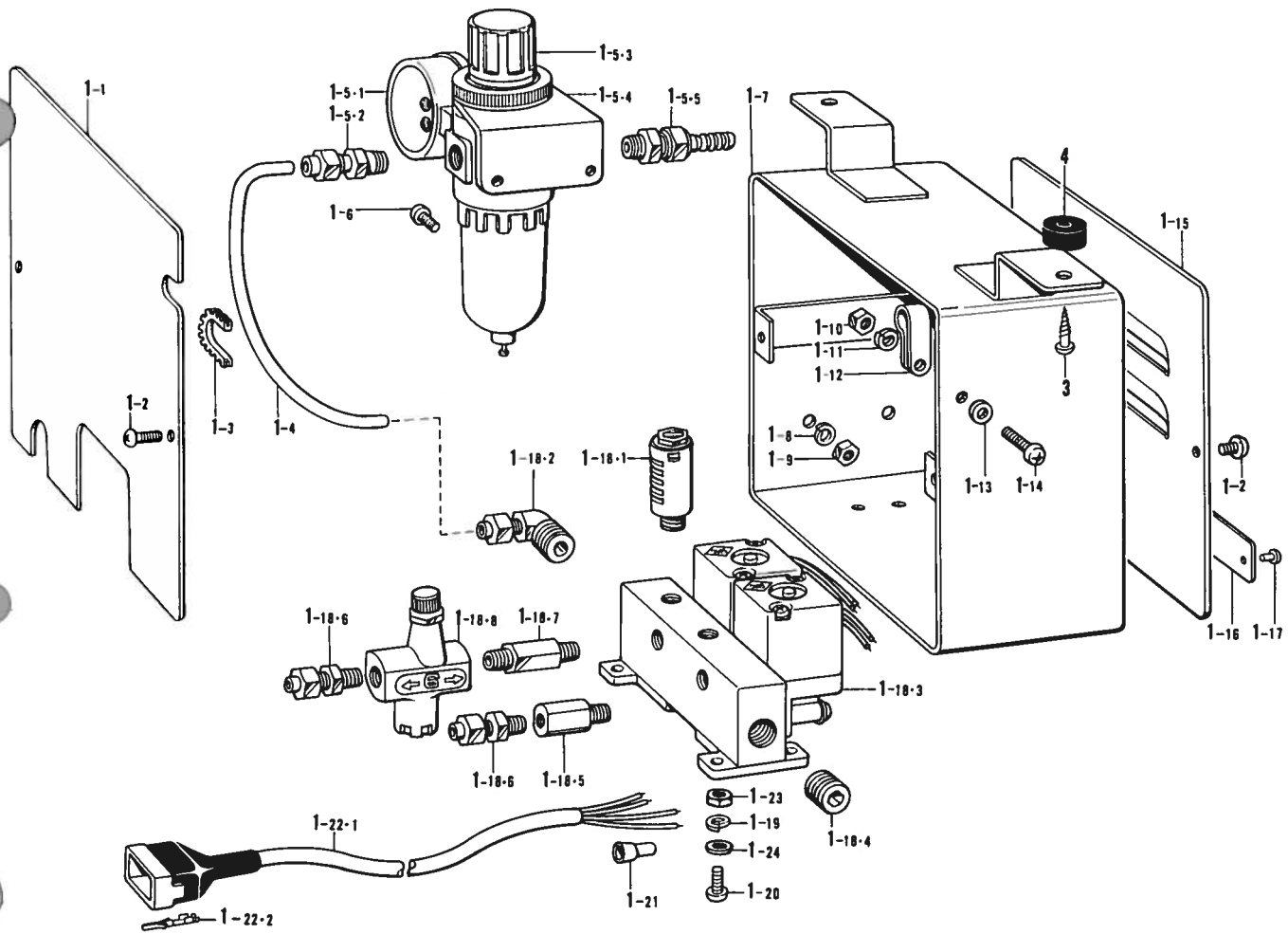

Ref. No.	Name of Parts	Q'ty	Parts No.	Assembly No.	Ref. No.	Name of Parts	Q'ty	Parts No.	Assembly No.
L-1-1	Rear Cover	1			L-1-16	Name Plate	1		
L-1-2	Screw	4	008400-5-64		L-1-17	Rivet	1		
L-1-3	Nylon Bushing	1	146171-0-00		L-1-18-1	Silencer	2	140682-0-01	
L-1-4	Air Tube	1	140540-0-00		L-1-18-2	1/4" Elbow	1	140538-0-00	
L-1-5-1	Presser Gauge	1		L-1-5 Air Filter Unit 143959-1-03	L-1-18-3	Solenoid Valve	1	149544-0-01	L-1-18 Solenoid Valve Assembly 149543-0-01
L-1-5-2	1/4" Connector Assembly	1	142349-0-00		L-1-18-4	1/4" Cap	1	140542-0-01	
L-1-5-3	Valve	1	143960-1-01		L-1-18-5	Valve Connector	1	140539-0-00	
L-1-5-4	Air Unit Holder Plate	1			L-1-18-6	1/8" Connector	2	140543-0-00	
L-1-5-5	Air Tube Connector	1	140678-0-00		L-1-18-7	Speed Control Connector	1	142037-0-00	
L-1-6	Screw	2	002501-0-64	L-1 Air Control Box Assembly 149539-0-01	L-1-18-8	Speed Controller	1	142038-0-01	L-1 Air Control Box Assembly 149539-0-01
L-1-7	Air Control Box	1			L-1-19	Washer	4	028040-2-43	
L-1-8	Washer	2	028050-2-43		L-1-20	Screw	4	002401-2-03	
L-1-9	Nut	2	021500-1-63		L-1-21	Connector	4	206755-0-00	
L-1-10	Nut	1	021300-1-03		L-1-22	Valve Cord	1	149545-0-01	
L-1-11	Washer	1	028030-2-43		L-1-23	Nut	4	021400-1-03	
L-1-12	Cord Holder	1	149547-0-00		L-1-24	Washer	4	025040-1-33	
L-1-13	Washer	1	025030-1-33		L-3	Screw	2	031483-2-03	
L-1-14	Screw	1	002301-0-03		L-4	Rubber Cushion	2	115018-0-01	
L-1-15	Front Cover	1							

M. Presser Lifter Mechanism (-500)

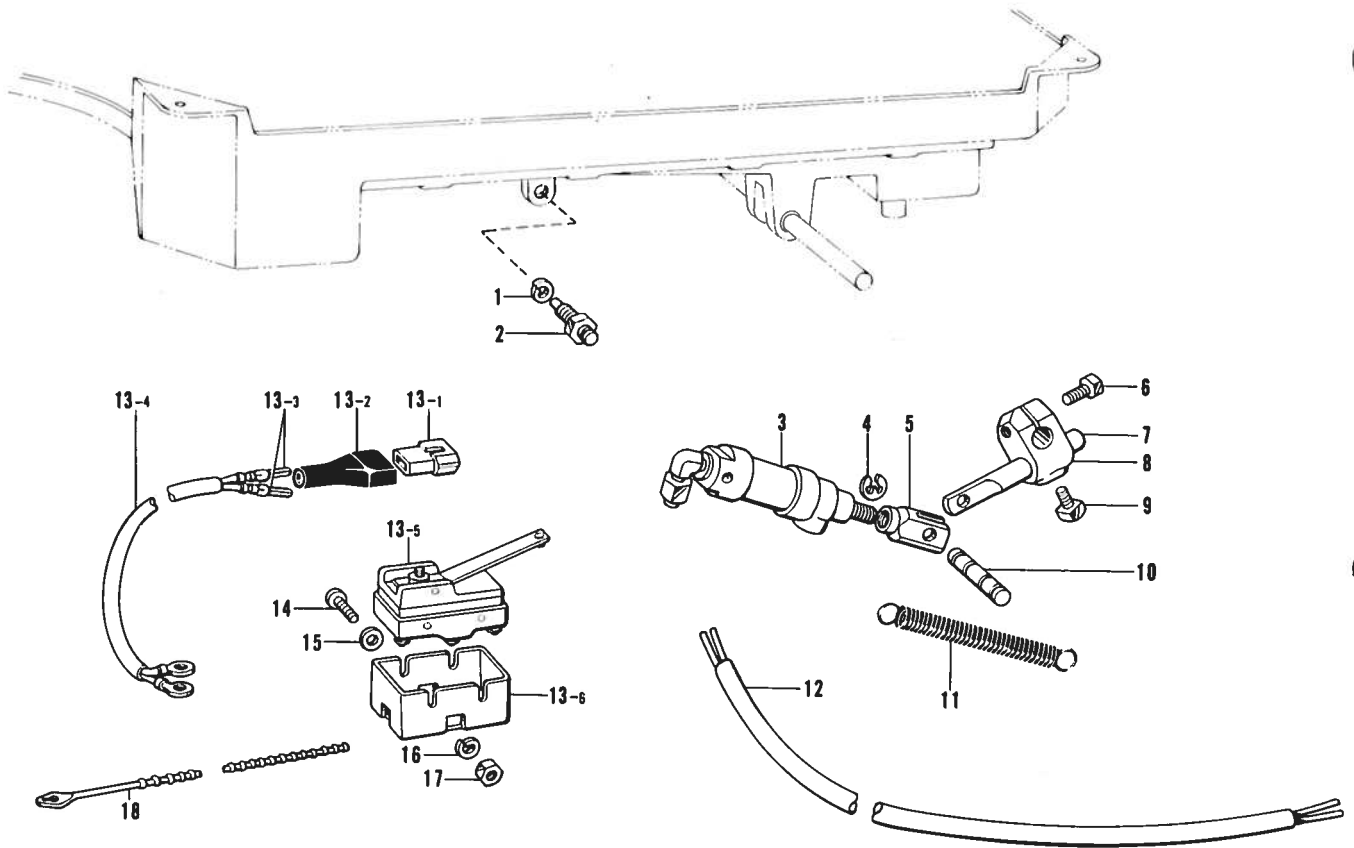

Ref. No.	Name of Parts	Q'ty	Parts No.	Assembly No.	Ref. No.	Name of Parts	Q'ty	Parts No.	Assembly No.
M- 1	Washer	2	028060-2-40		M-12	Air Tube	1	149548-0-01	
M- 2	Screw	2	147141-0-01		M-13-1	Nylon Connector	1	143488-0-01	M-13 Presser Foot Lifter Cord Assembly 146160-0-01
M- 3	Presser Foot Cylinder	1	146157-0-01		M-13-2	Connector Cap	1	143489-0-01	
M- 4	Stop Ring	2	048040-3-42		M-13-3	Terminal Pin	2	143549-0-00	
M- 5	Piston Rod Joint	1	140627-0-01		M-13-4	Presser Foot Lifter Cord	1	146161-0-00	
M- 6	Bolt	1	017762-0-13		M-13-5	Micro Switch	1	140948-0-01	
M- 7	Piston Drive Link	1	140668-0-01		M-13-6	Cover	1	140950-0-00	
M- 8	Knee Lifter Joint	1	146039-0-01		M-14	Screw	2	002303-0-06	
M- 9	Bolt	1	100463-0-01		M-15	Washer	2	025030-2-33	
M-10	Pin	1	146986-0-01		M-16	Washer	2	028030-2-43	
M-11	Spring	2	146985-0-01		M-17	Nut	2	021300-1-03	
					M-18	Bead Band	1	144189-0-01	

Z. Accessories

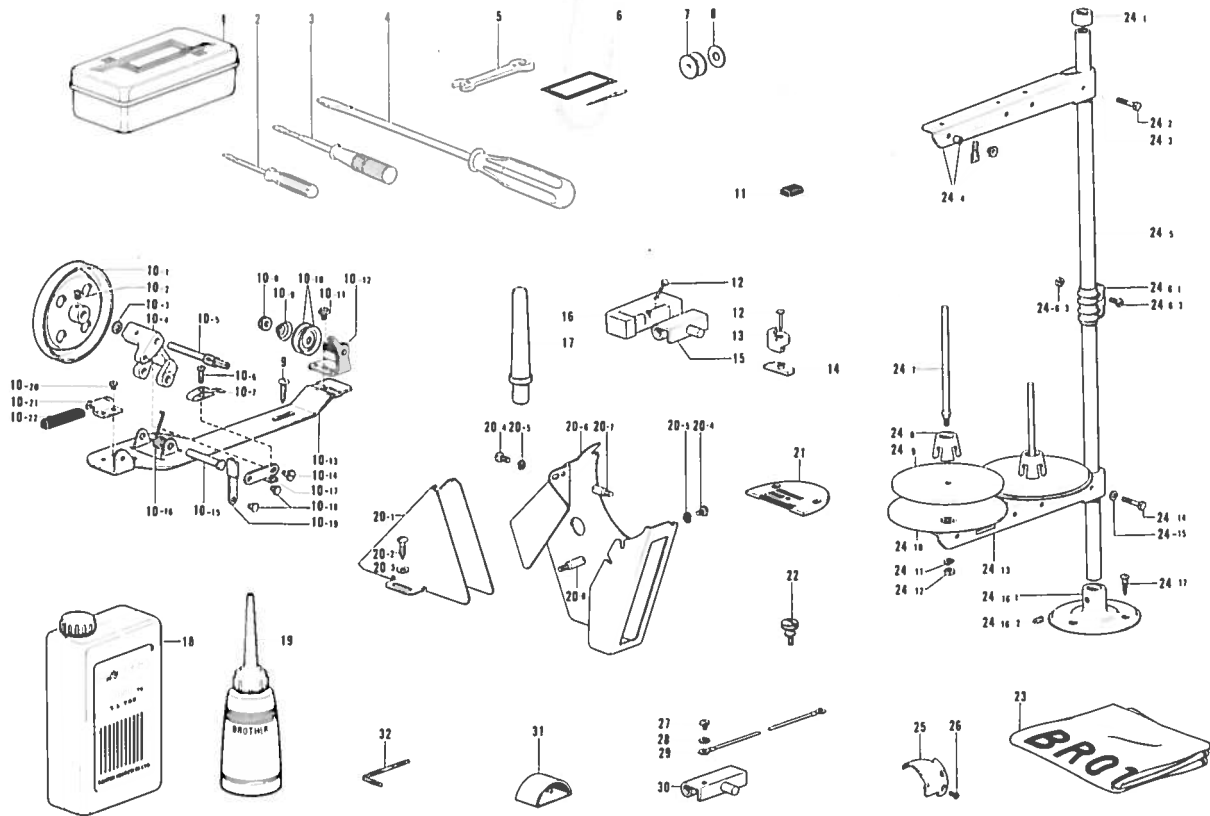

Ref. No.	Name of Parts	Q'ty	Parts No.	Assembly No.	Ref. No.	Name of Parts	Q'ty	Parts No.	Assembly No.
Z- 1	Accessory Box		110436-0-01		Z-18	Oil Tank		145277-1-03	
Z- 2	Screw Driver		142443-0-01		Z-19	Oiler		114483-0-01	
Z- 3	Screw Driver		118837-0-01		Z-20- 1	Belt Cover D			Z 20 Belt Cover Assembly
Z- 4	Screw Driver		101572-1-01		Z-20- 2	Screw		100666-0-02	
Z- 5	Spanner		100887-0-01		Z-20- 3	Washer		025750-1-32	
Z- 6	Needle				Z-20- 4	Screw		009680-8-12	
Z- 7	Bobbin		146290-0-01		Z-20- 5	Washer		028680-2-42	
Z- 8	Bobbin Case Sheet				Z-20- 6	Belt Cover UA			
Z- 9	Screw		100666-0-02		Z-20- 7	Stud		147856-0-01	
Z-10- 1	Bobbin Winder Wheel Assembly			Z-10 Bobbin Winder Assembly 117963-0-01	Z-20- 8	Stud		147855-0-01	
Z-10- 2	Screw		100366-0-02		Z-21	Needle Plate			
Z-10- 3	Washer				Z-22	Screw			
Z-10- 4	Bobbin Winder Wheel Shaft Bushing				Z-23	Head Cover			144222-0-01
Z-10- 5	Bobbin Winder Shaft		117970-0-01		Z-24- 1	Cap			
Z-10- 6	Screw		100657-0-01		Z-24- 2	Bolt		017502-8-03	
Z-10- 7	Bobbin Presser				Z-24- 3	Wa hcr		025050-2-33	
Z-10- 8	Nut				Z-24- 4	Thread H nger A mbly		150192-0-01	
Z-10- 9	Spring		100401-0-01		Z-24- 5	Pipc		150172-0-01	
Z-10-10	Tension Disc		145446-0-01		Z-24- 6-1	Jou t		150173-0-01	Z-24-6 Joint Assembly 150106-0-01
Z-10-11	Screw				Z-24- 6-2	Scr w		150202-0-01	
Z-10-12	Bobbin Winder Wheel Guide Bracket Assembly				Z-24- 6-3	Nut		021500-1-03	Z-24 Cotton Stand Assembly
Z-10-13	Bobbin Winder Wheel Bracket				Z-24- 7	Spool shaft		150179-0-01	
Z-10-14	Screw		100659-0-01		Z-24- 8	Spoo C hon		147060-0-01	
Z-10-15	Pin				Z-24- 9	Spool Mat		150182-0-00	
Z-10-16	Spring		117969-0-01		Z-24-10	Spool tar d Base		150180-0-00	
Z-10-17	Bobbin Presser Arm				Z-24-11	Spring Wa her		028050-2-43	
Z-10-18	Pin		100661-0-01		Z-24-12	Nut		021500-1-03	
Z-10-19	Bobbin Presser Arm Bracket				Z-24-13	Spoo Hc d r Assembl		150177-0-01	
Z-10-20	Screw		009679-3-12		Z-24-14	Bolt		017502-8-03	
Z-10-21	Bobbin Winder Wheel Stopper Holder				Z-24-15	Wa hcr		025050 2 33	
Z-10-22	Bobbin Winder Wheel Stopper		100662-0-01		Z-24-16-1	Cotton Stand Base		150189-0-01	Z-24-16 Cotton Stand Base Assembly 150139-0-01
Z-11	Magnet		112525-0-00	Z-24-16-2	Screw		150181-0-01		
Z-12	Nail		109714-0-00	Z-24-17	Screw		031452 2 03		
Z-13	Head Cushion		146003-1-01	Z-25	Movable Knife				
Z-14	Oil Pan Cushion		146004-0-01	Z-26	Screw		141542-0-01		
Z-15	Hinge		143882-0-01	Z-27	Screw		009680-6-13		
Z-16	Blower		143910-0-01	Z-28	Washer		025680-2-34		
Z-17	Head Rest		100477-0-01	Z-29	Earth Wire		145946-0-01		
				Z-30	Head Hinge		145945-0-01		
				Z-31	Movadle Knife Case		145990-0-01		
				Z-32	Spanner		146049-0-01		

* The details of included accessories are subject to change.

* Änderungen in der Aufstellung der mitgelieferten Zubehöre sind vorbehalten.

* Les détails des accessoires inclus sont sujets à des changements.

* Los detalles de los accesorios incluidos pueden variar.

DIFFERENT PARTS LIST

-3

Ref. No.	Name of Parts	Sub Class		3										
		Motor Spec.	Destination	Germany. France	England. France	Spain	Tiwan				Iraq	Spain		
A- 2	Oil Cap													112782-0-01
A- 4	Face Plate													111455-0-01
A- 6	Screw													108960-0-02
A- 7	Face Plate Thread Guide													111476-0-01
A- 8	Oil Stopper Plate Assembly				181641-0-01		181639-0-01							181641-0-01
A-20	Pretension Assembly													144502-0-01
A-21	Rear Cover													118673-0-01
A-32	Tension Regulator Assembly													181473-0-01
A-32-2	Tension Spring													104525-0-01
A-32-6	Thread Take-up Spring													100399-0-01
A-33	Tension Release Pin													146065-0-00
A-37	Oil Cap													104833-0-01
A-40	Needle Plate													100266-0-01
B- 4	Thread Take-up Lever Assembly				116732-0-01		147551-0-01							116732-0-01
B- 4-3	Needle Roller Bearing				116735-0-00		147777-0-00							116735-0-00
B- 4-5	Cap													145600-0-00
B- 4-9	Needle Bar Connector				140353-0-01		145466-0-01							140353-0-01
B-12	Needle Bar		145268-0-01											111462-0-01
B-14	Needle Bar Bushing Lower		142116-0-01											117243-0-01
B-16	Needle Bar Thread Guide													112775-0-01
B-18	Needle		107415-0-14											100265-0-34
B-22	Thread Take-up Crank				142782-0-00		148965-0-00							142782-0-00
B-45	Pulley													115244-0-01
C- 5	Feed Dog													100334-0-01
C-18	Lower Shaft													109160-0-01
C-19	Felt													106436-0-01
C-22	Screw													107407-0-03
C-23	Bobbin Case Assembly													100369-0-01
C-24	Bobbin Case Sheet													140356-0-01
C-26	Rotary Hook Assembly													116780-0-01
C-27	Oil Stopper Assembly													144943-0-01
C-47	Bobbin Presser Spring													
D- 4	Eccentric Wheel													180792-0-01
D-11	Spring													118753-0-01
D-15	Reverse Lever Assembly													181678-0-01
D-15-4	Reverse Lever													118752-0-01
E-12	Presser Foot													113280-0-01
E-13	Hinge Screw													109163-0-01
E-14	Tension Release Lever													111470-0-00
E-15	Tension Release Lever Spring													100405-0-01

Ref. No.	Name of Parts	Sub Class Motor Spec Destination	3									
			Germany, France	England, France	Spain	Tiwan		Iraq	Spain			
24	Washer	025350 1-34										
E-25	Finger Guard	150384 0-01										
F-25	Oil Pan Assembly							181120-2-01				
F-25-1	Oil Pan							149580-0-01				
F-25-3	Knee Lifter Shaft							146036 1-01				
F-25-8	Spring							146038 0-01				
G-9	Screw											
G-10	Tension Release Solenoid Assembly											
G-13	Supporter											
G-14	Connector Cap											
G-15	Nylon Connector											
18	Thread Trimming Solenoid Assembly											
G-32	Movable Knife											
G-34	Spacer											
G-44	Rotary Solenoid											
G-45	Thread Trimming Solenoid											
G-46	Tube Holder											
G-47	Cord Holder											
G-48	Cord Holder											
G-49	Cord Holder											
H-2	Synchronizer Assembly											
H-3	Synchronizer Holder Bar											
H-5	Holder											
H-6	Slip Ring Support											
J-5	Cord											
J-27	Switch											
J-31	Cord											
J-32	Switch											
K-5	Reverse Solenoid Assembly											
K-6	6P Connector											
K-7	Connector Cap											
K-33	Reverse Solenoid											
Z-6	Needle	107415-0-14						100265-0-34				
Z-8	Bobbin Case Sheet							140356-0-01				
Z-20	Belt Cover Assembly	147895-0-11							147895-0-11			
Z-21	Needle Plate							100267 0-01				
Z-22	Screw							106120-0-03				
Z-24	Cotton Stand Assembly	150150-0-01							150150-0-01			150150-0-01
Z-25	Movable Knife											

Ref. No.	Name of Parts	Sub Class	5					
		Motor Spec.	France	France			Spain	Spain
		Destination						
A- 2	Oil Cap							112782-0-01
A- 4	Face Plate							111455-0-01
A- 6	Screw							108960-0-02
A- 7	Face Plate Thread Guide							111476-0-01
A- 8	Oil Stopper Plate Assembly							181641-0-01
A-20	Pretension Assembly							144502-0-01
A-21	Rear Cover							118673-0-01
A-32	Tension Regulator Assembly							181473-0-01
A-32-2	Tension Spring							104525-0-01
A-32-6	Thread Take-up Spring							100399-0-01
A-33	Tension Release Pin							146065-0-00
A-37	Oil Cap							104833-0-01
A-40	Needle Plate							100267-0-01
B- 4	Thread Take-up Lever Assembly							116732-0-01
B- 4-3	Needle Roller Bearing							116735-0-00
B- 4-5	Cap							145600-0-00
B- 4-9	Needle Bar Connector							140353-0-01
B-12	Needle Bar							145268-0-01
B-14	Needle Bar Bushing Lower							142116-0-01
B-16	Needle Bar Thread Guide							112775-0-01
B-18	Needle		107415-0-18					100265-0-41
B-22	Thread Take-up Crank							111465-0-00
B-45	Pulley							115244-0-01
C- 5	Feed Dog							100334-0-01
C-18	Lower Shaft							109160-0-01
C-19	Felt							106436-0-01
C-22	Screw							107407-0-03
C-23	Bobbin Case Assembly							100369-0-01
C-24	Bobbin Case Sheet							140356-0-01
C-26	Rotary Hook Assembly							116780-0-01
C-27	Oil Stopper Assembly							144943-0-01
C-47	Bobbin Presser Spring							
D- 4	Eccentric Wheel							145269-0-01
D-11	Spring							145643-0-01
D-15	Reverse Lever Assembly							181678-0-01
D-15-4	Reverse Lever							118752-0-01
E-12	Presser Foot							113280-0-01
E-13	Hinge Screw							109163-0-01
E-14	Tension Release Lever							111470-0-00
E-15	Tension Release Lever Spring							100405-0-01

Ref. No.	Name of Parts	Sub Class		5							
		Motor Spec.	Destination	France	France				Spain		Spain
24	Washer			025350-1-34							
E-25	Finger Guard			150384-0-01							
F-25	Oil Pan Assembly									181420-2-01	
F-25-1	Oil Pan									149580-0-01	
F-25-3	Knee Lifter Shaft									146036-1-01	
F-25-8	Spring									146038-0-01	
G-9	Screw										
G-10	Tension Release Solenoid Assembly										
G-13	Supporter										
G-14	Connector Cap										
G-15	Nylon Connector										
G-18	Thread Trimming Solenoid Assembly										
G-32	Movable Knife										
G-34	Spacer										
G-44	Rotary Solenoid										
G-45	Thread Trimming Solenoid										
G-46	Tube Holder										
G-47	Cord Holder										
G-48	Cord Holder										
G-49	Cord Holder										
H-2	Synchronizer Assembly										
H-3	Synchronizer Holder Bar										
H-5	Holder										
H-6	Slip Ring Support										
J-5	Cord										
27	Switch										
J-31	Cord										
J-32	Switch										
K-5	Reverse Solenoid Assembly										
K-6	6P Connector										
K-7	Connector Cap										
K-33	Reverse Solenoid										
Z-6	Needle			107415-0-18						100265-0-41	
Z-8	Bobbin Case Sheet									140356-0-01	
Z-20	Belt Cover Assembly			147895-0-11							147895-0-11
Z-21	Needle Plate									100267-0-01	
Z-22	Screw									106120-0-03	
Z-24	Cotton Stand Assembly			150150-0-01						150150-0-01	150150-0-01
Z-25	Movable Knife										

Ref. No.	Name of Parts	Sub Class Motor Spec Destination	103			105		
			Brother	Efka	Germany, France	Brother	Efka	Germany, France
A-2	Oil Cap			117 82-0-01			112782 0 01	
A-4	Face Plate			111455-0-01			11145 0 01	
A-6	Screw							
A-7	Face Plate Thread Guide							
A-8	Oil Stopper Plate Assembly			181641 0 01			181641 0 01	
A-20	Pretension Assembly							
A-21	Rear Cover			118673 0 01			118673 0 01	
A-32	Tension Regulator Assembly			181473 0 01			181635 0 01	
A-32-2	Tension Spring			104525 0 01			11515 0 01	
A-32-6	Thread Take-up Spring			100399 0 01			11519 0 01	
A-33	Tension Release Pin			116065 0 00			116065 0 00	
A-37	Oil Cap			142274 0 01			142274-0-01	
A-40	Needle Plate			145971 0 01			147245-0-01	
B-4	Thread Take-up Lever Assembly			116732 0 01			116732 0 01	
B-4-3	Needle Roller Bearing			116735 0 00			116735 0 00	
B-4-5	Cap			145600 0 00			115600 0 00	
B-4-9	Needle Bar Connector			140353 0 01			110353 0 01	
B-12	Needle Bar			145467-0-01		117518 0 01	115986 0 01	
B-14	Needle Bar Bushing Lower			117243 0 01			112116 0 01	
B-16	Needle Bar Thread Guide			145944 0 01			115944 0 01	
B-18	Needle			100265-0-34		107150 14	100265 0 1	
B-22	Thread Take-up Crank			142782 0 00			111165 0 00	
B-45	Pulley			148823 0 01			111823 0 0	
C-5	Feed Dog			100140 0 01			144500 0 01	
C-18	Lower Shaft			115170 0 01			1151 0 01	
C-19	Felt			147510 0 01			14510 0 01	
C-22	Screw			009681-0 12			0096 1 0	
C-23	Bobbin Case Assembly			148501 0 01			1450 0	
C-24	Bobbin Case Sheet							
C-26	Rotary Hook Assembly			14585-1-01			14585-1-01	
C-27	Oil Stopper Assembly							
C-47	Bobbin Presser Spring			14896 1-01			14896 0	
D-4	Eccentric Wheel			184792-0-01			145269 0 01	
D-11	Spring			118753 0 01			464 0 01	
D-15	Reverse Lever Assembly			181678-0-01			1167 0 0	
D-15-4	Reverse Lever			118752-0-01			187.2 0 01	
E-12	Presser Foot			140957-0-01			11 0 01	
E-13	Hinge Screw			109163-0-01			1096 0 01	
E-14	Tension Release Lever			111470-0-00			1470 0 00	
E-15	Tension Release Lever Spring			100405-0-01			0040 0 0	

Ref. No.	Name of Parts	Sub Class Motor Spec. Destination	103				105			
			Brother		Efka		Brother		Efka	
						Germany. France				
24	Washer					025350-1-34				
E-25	Finger Guard					150384-0-01				
F-25	Oil Pan Assembly			181420-2-01				181420-2-01		
F-25-1	Oil Pan			149580-0-01				149580-0-01		
F-25-3	Knee Lifter Shaft			146036-1-01				146036-1-01		
F-25-8	Spring			146038-0-01				146038-0-01		
G-9	Screw			001639-3-12				001639-3-12		
G-10	Tension Release Solenoid Assembly		147107-0-01					147107-0-01		
G-13	Supporter			140647-0-01				140647-0-01		
G-14	Connector Cap		145596-0-01					145596-0-01		
G-15	Nylon Connector		145681-0-00					145681-0-00		
G-18	Thread Trimming Solenoid Assembly		146014-0-01					146014-0-01		
G-32	Movable Knife			145608-0-01				146187-0-00		
G-34	Spacer			145611-0-00				145610-1-01		
G-44	Rotary Solenoid				148852-0-01				148852-0-01	
G-45	Thread Trimming Solenoid				146910-0-01				146910-0-01	
G-46	Tube Holder									
G-47	Cord Holder									
G-48	Cord Holder									
G-49	Cord Holder									
H-2	Synchronizer Assembly		218931-0-01					218931-0-01		
H-3	Synchronizer Holder Bar				218944-0-01				218944-0-01	
H-5	Holder				216332-0-01				216332-0-01	
H-6	Slip Ring Support				148825-0-01				148825-0-01	
J-5	Cord									
J-27	Switch									
J-31	Cord									
J-32	Switch									
K-5	Reverse Solenoid Assembly									
K-6	6P Connector									
K-7	Connector Cap									
K-33	Reverse Solenoid									
Z-6	Needle			100265-0-34		107415-0-14			100265-0-42	
Z-8	Bobbin Case Sheet									
Z-20	Belt Cover Assembly				147895-0-11				147895-0-11	
Z-21	Needle Plate				100266-0-01				100266-0-01	
Z-22	Screw									
Z-24	Cotton Stand Assembly			150150-0-01		150150-0-01			150150-0-01	
Z-25	Movable Knife				145608-0-01				147981-0-01	

Ref. No.	Name of Parts	Sub Class		203		205	
		Motor Spec.	Destination	Brother		Efka	
A- 2	Oil Cap			104449-0-01		104449-0-01	
A- 4	Face Plate			148330-0-01		148330-0-01	
A- 6	Screw						
A- 7	Face Plate Thread Guide						
A- 8	Oil Stopper Plate Assembly			181641-0-01		181641-0-01	
A-20	Pretension Assembly						
A-21	Rear Cover			118673-0-01		118673-0-01	
A-32	Tension Regulator Assembly			181473-0-01		181635-0-01	
A-32-2	Tension Spring			104525-0-01		145153-0-01	
A-32-6	Thread Take-up Spring			100399-0-01		145519-0-01	
A-33	Tension Release Pin			146065-0-00		146065-0-00	
A-37	Oil Cap			142274-0-01		142274-0-01	
A-40	Needle Plate			145971-0-01		147245-0-01	
B- 4	Thread Take-up Lever Assembly			116732-0-01		116732-0-01	
B- 4-3	Needle Roller Bearing			116735-0-00		116735-0-00	
B- 4-5	Cap			145600-0-00		145600-0-00	
B- 4-9	Needle Bar Connector			140353-0-01		140353-0-01	
B-12	Needle Bar			145467-0-01		145986-0-01	
B-14	Needle Bar Bushing Lower			117243-0-01		142116-0-01	
B-16	Needle Bar Thread Guide			145944-0-01		145944-0-01	
B-18	Needle			100265-0-34		100265-0-42	
B-22	Thread Take-up Crank			142782-0-00		111465-0-00	
B-45	Pulley			148823-0-01		148823-0-01	
C- 5	Feed Dog			100334-0-01		144500-0-01	
C-18	Lower Shaft			145517-0-01		145517-0-01	
C-19	Felt			145751-0-01		145751-0-01	
C-22	Screw			009681-0-12		009681-0-12	
C-23	Bobbin Case Assembly			148350-1-01		148350-1-01	
C-24	Bobbin Case Sheet						
C-26	Rotary Hook Assembly			145585-1-01		145585-1-01	
C-27	Oil Stopper Assembly						
C-47	Bobbin Presser Spring			148967-1-01		148967-1-01	
D- 4	Eccentric Wheel			180792-0-01		145269-0-01	
D-11	Spring			118753-0-01		145643-0-01	
D-15	Reverse Lever Assembly			181678-0-01		181678-0-01	
D-15-4	Reverse Lever			118752-0-01		118752-0-01	
E-12	Presser Foot			140957-0-01		145157-0-01	
E-13	Hinge Screw			109163-0-01		109163-0-01	
E-14	Tension Release Lever			111470-0-00		111470-0-00	
E-15	Tension Release Lever Spring			100405-0-01		100405-0-01	

Ref. No.	Name of Parts	Sub Class Moter Spec. Destination	203		205	
			Brother	Efka	Brother	Efka
24	Washer					
E-25	Finger Guard					
F-25	Oil Pan Assembly		181420-2-01		181420-2-01	
F-25-1	Oil Pan		149580-0-01		149580-0-01	
F-25-3	Knee Lifter Shaft		146036-1-01		146036-1-01	
F-25-8	Spring		146038-0-01		146038-0-01	
G- 9	Screw		001639-3-12		001639-3-12	
G-10	Tension Release Solenoid Assembly		147107-0-01		147107-0-01	
G-13	Supporter					
G-14	Connector Cap		146119-0-00		146119-0-00	
G-15	Nylon Connector		145681-0-00		145681-0-00	
G-18	Thread Trimming Solenoid Assembly		146014-0-01		146014-0-01	
G-32	Movable Knife		145608-0-01		147981-0-01	
G-34	Spacer		145611-0-00		146187-0-00	
G-44	Rotary Solenoid			148852-0-01		148852-0-01
G-45	Thread Trimming Solenoid			146910-0-01		146910-0-01
G-46	Tube Holder		142268-0-01		142268-0-01	
G-47	Cord Holder					
G-48	Cord Holder					
G-49	Cord Holder					
H- 2	Synchronizer Assembly		218931-0-01		218931-0-01	
H- 3	Synchronizer Holder Bar			218944-0-01		218944-0-01
H- 5	Holder			216332-0-01		216332-0-01
H- 6	Slip Ring Support			148825-0-01		148825-0-01
J - 5	Cord		146095-0-00		146095-0-00	
27	Switch					
J-31	Cord			146912-0-00		146912-0-00
J-32	Switch					
K- 5	Reverse Solenoid Assembly					
K- 6	6P Connector					
K- 7	Connector Cap					
K-33	Reverse Solenoid					
Z- 6	Needle		100265-0-34		100265-0-42	
Z- 8	Bobbin Case Sheet					
Z-20	Belt Cover Assembly		147895-0-11		147895-0-11	
Z-21	Needle Plate		100266-0-01		100266-0-01	
Z-22	Screw					
Z-24	Cotton Stand Assembly		150150-0-01		150150-0-01	
Z-25	Movable Knife		145608-0-01		147981-0-01	

Ref. Npo.	Name of Parts	Sub Class Motor Spec. Destination	403				405			
			Brother		Efka		Brother		Efka	
A- 2	Oil Cap				104449-0-01					104449-0-01
A- 4	Face Plate				148330-0-01					148330-0-01
A- 6	Screw									
A- 7	Face Plate Thread Guide									
A- 8	Oil Stopper Plate Assembly				181641-0-01					181641-0-01
A-20	Pretension Assembly									
A-21	Rear Cover				148452-0-01					148452-0-01
A-32	Tension Regulator Assembly				181473-0-01					181635-0-01
A-32-2	Tension Spring				104525-0-01					145153-0-01
A-32-6	Thread Take-up Spring				100399-0-01					145519-0-01
A-33	Tension Release Pin				146065-0-00					146065-0-00
A-37	Oil Cap				142274-0-01					142274-0-01
A-40	Needle Plate				145971-0-01					147245-0-01
B- 4	Thread Take-up Lever Assembly				116732-0-01					116732-0-01
B- 4-3	Needle Roller Bearing				116735-0-00					116735-0-00
B- 4-5	Cap				145600-0-00					145600-0-00
B- 4-9	Needle Bar Connector				140353-0-01					140353-0-01
B-12	Needle Bar				145467-0-01					145986-0-01
B-14	Needle Bar Bushing Lower				117243-0-01					142116-0-01
B-16	Needle Bar Thread Guide				145944-0-01					145944-0-01
B-18	Needle				145971-0-01					147245-0-01
B-22	Thread Take-up Crank				142782-0-00					111465-0-00
B-45	Pulley				148823-0-01					148823-0-01
C- 5	Feed Dog				100334-0-01					144500-0-01
C-18	Lower Shaft				145517-0-01					145517-0-01
C-19	Felt				145751-0-01					145751-0-01
C-22	Screw				009681-0-12					009681-0-12
C-23	Bobbin Case Assembly				148350-1-01					148350-1-01
C-24	Bobbin Case Sheet									
C-26	Rotary Hook Assembly				145585-1-01					145585-1-01
C-27	Oil Stopper Assembly									
C-47	Bobbin Presser Spring				148967-1-01					148967-1-01
D- 4	Eccentric Wheel				180792-0-01					145269-0-01
D-11	Spring				148459-0-01					148459-0-01
D-15	Reverse Lever Assembly				181714-0-01					181714-0-01
D-15-4	Reverse Lever				148458-0-01					148458-0-01
E-12	Presser Foot				140957-0-01					145157-0-01
E-13	Hinge Screw				109163-0-01					109163-0-01
E-14	Tension Release Lever				111470-0-00					111470-0-00
E-15	Tension Release Lever Spring				100405-0-01					100405-0-01

Ref. No.	Name of Parts	Sub Class Motor Spec Destination	403			405		
			Brother	Efka		U.S.A., Canada	Brother	Efka
E-24	Washer							
E-25	Finger Guard							
F-25	Oil Pan Assembly			181420-2-01			181420-2-01	
F-25-1	Oil Pan			149580-0-01			149580-0-01	
F-25-3	Knee Lifter Shaft			146036-1-01			146036-1-01	
F-25-8	Spring			146038-0-01			146038-0-01	
G-9	Screw							
G-10	Tension Release Solenoid Assembly		147107-0-01				147107-0-01	
G-13	Supporter							
G-14	Connector Cap		146119-0-00				146119-0-00	
G-15	Nylon Connector		145681-0-00				145681-0-00	
G-18	Thread Trimming Solenoid Assembly		146014-0-01				146014-0-01	
G-32	Movable Knife			145608-0-01			147981-0-01	
G-34	Spacer			145611-0-00			146187-0-00	
G-44	Rotary Solenoid			148852-0-01	151247-0-01			148852-0-01
G-45	Thread Trimming Solenoid			146910-0-01	151187-0-01			146910-0-01
G-46	Tube Holder							
G-47	Cord Holder							
G-48	Cord Holder			148856-0-01			148856-0-01	
G-49	Cord Holder			148462-0-01			148462-0-01	
H-2	Synchronizer Assembly		218931-0-01				218931-0-01	
H-3	Synchronizer Holder Bar			218944-0-01				218944-0-01
H-5	Holder			216332-0-01				216332-0-01
H-6	Slip Ring Support			148825-0-01				148825-0-01
J-5	Cord		146095-0-00				146095-0-00	
J-27	Switch		146121-0-00				146121-0-00	
J-31	Cord			146912-0-00	151183-0-01			146912-0-00
J-32	Switch			146913-0-00	151185-0-01			146913-0-00
K-5	Reverse Solenoid Assembly		147756-0-01				147756-0-01	
K-6	6P Connector		146118-0-00				146118-0-00	
K-7	Connector Cap		145596-0-01				145596-0-01	
K-33	Reverse Solenoid			147757-0-01	151181-0-01			147757-0-01
Z-6	Needle			100265-0-34			100265-0-42	
Z-8	Bobbin Case Sheet							
Z-20	Belt Cover Assembly			147895-0-11			147895-0-11	
Z-21	Needle Plate			100266-0-01			100266-0-01	
Z-22	Screw							
Z-24	Cotton Stand Assembly			150150-0-01		150150-0-01		150150-0-01
Z-25	Movable Knife			145608-0-01			147981-0-01	

Ref. No.	Name of Parts	Sub Class Motor Spec. Destination	503				505				
			Brother		Efka		Brother		Efka		
						Germany, France	U.S.A., Canada				
A-2	Oil Cap		104449-0-01				104449-0-01				
A-4	Face Plate		148330-0-01				148330-0-01				
A-6	Screw										
A-7	Face Plate Thread Guide										
A-8	Oil Stopper Plate Assembly		181641-0-01				181641-0-01				
A-20	Pretension Assembly										
A-21	Rear Cover		148452-0-01				148452-0-01				
A-32	Tension Regulator Assembly		181473-0-01				181635-0-01				
A-32-2	Tension Spring		104525-0-01				145153-0-01				
A-32-6	Thread Take-up Spring		100399-0-01				145519-0-01				
A-33	Tension Release Pin										
A-37	Oil Cap		142274-0-01				142274-0-01				
A-40	Needle Plate		145971-0-01				147245-0-01				
B-4	Thread Take-up Lever Assembly		116732-0-01				116732-0-01				
B-4-3	Needle Roller Bearing		116735-0-00				116735-0-00				
B-4-5	Cap		145600-0-00				145600-0-00				
B-4-9	Needle Bar Connector		140353-0-01				140353-0-01				
B-12	Needle Bar		145467-0-01		147518-0-01	145467-0-01		145986-0-01			
B-14	Needle Bar Bushing Lower		117243-0-01				142116-0-01				
B-16	Needle Bar Thread Guide		145944-0-01				145944-0-01				
B-18	Needle		100265-0-34		107415-0-14	100265-0-34		100265-0-42			
B-22	Thread Take-up Crank		142782-0-00				111465-0-00				
B-45	Pulley		148823-0-01				148823-0-01				
C-5	Feed Dog		100334-0-01				144500-0-01				
C-18	Lower Shaft		145517-0-01				145517-0-01				
C-19	Felt		145751-0-01				145751-0-01				
C-22	Screw		009681-0-12				009681-0-12				
C-23	Bobbin Case Assembly		148350-1-01				148350-1-01				
C-24	Bobbin Case Sheet										
C-26	Rotary Hook Assembly		145585-1-01				145585-1-01				
C-27	Oil Stopper Assembly										
C-47	Bobbin Presser Spring		148967-1-01				148967-1-01				
D-4	Eccentric Wheel		180792-0-01				145269-0-01				
D-11	Spring		145643-0-01				145643-0-01				
D-15	Reverse Lever Assembly		181714-0-01				181714-0-01				
D-15-4	Reverse Lever		148458-0-01				148458-0-01				
E-12	Presser Foot		140957-0-01				145157-0-01				
E-13	Hinge Screw										
E-14	Tension Release Lever										
E-15	Tension Release Lever Spring										

Ref. No.	Name of Parts	Sub Class Motor Spec Destination	503				505			
			Brother		Efka		Brother		Efka	
					Germany. France	U.S.A., Canada				
E-24	Washer				025350-1-34					
E-25	Finger Guard				150384-0-01					
F-25	Oil Pan Assembly			181430-2-01				181430-2-01		
F-25-1	Oil Pan			149581-0-01				149581-0-01		
F-25-3	Knee Lifter Shaft			146069-0-01				146069-0-01		
F-25-8	Spring			146985-0-01				146985-0-01		
G-9	Screw									
G-10	Tension Release Solenoid Assembly		147107-0-01					147107-0-01		
G-13	Supporter									
G-14	Connector Cap		146119-0-00					146119-0-00		
G-15	Nylon Connector		145681-0-00					145681-0-00		
G-18	Thread Trimming Solenoid Assembly		146014-0-01					146014-0-01		
G-32	Movable Knife			145608-0-01				147981-0-01		
G-34	Spacer			145611-0-00				146187-0-00		
G-44	Rotary Solenoid			148852-0-01		151247-0-01		148852-0-01		
G-45	Thread Trimming Solenoid			146910-0-01		151187-0-01		146910-0-01		
G-46	Tube Holder									
G-47	Cord Holder			148462-0-01				148462-0-01		
G-48	Cord Holder									
G-49	Cord Holder									
H-2	Synchronizer Assembly		218931-0-01					218931-0-01		
H-3	Synchronizer Holder Bar			218944-0-01				218944-0-01		
H-5	Holder			216332-0-01				216332-0-01		
H-6	Slip Ring Support			148825-0-01				148825-0-01		
J-5	Cord		146095-0-00					146095-0-00		
J-27	Switch		146121-0-00					146121-0-00		
J-31	Cord			146912-0-00		151183-0-01		146912-0-00		
J-32	Switch			146913-0-00		151185-0-01		146913-0-00		
K-5	Reverse Solenoid Assembly									
K-6	6P Connector									
K-7	Connector Cap									
K-33	Reverse Solenoid									
Z-6	Needle		100265-0-34		107415-0-14	100265-0-34		100265-0-42		
Z-8	Bobbin Case Sheet									
Z-20	Belt Cover Assembly			147895-0-11				147895-0-11		
Z-21	Needle Plate			100266-0-01				100266-0-01		
Z-22	Screw									
Z-24	Cotton Stand Assembly		150150-0-01			150150-0-01		150150-0-01		
Z-25	Movable Knife			145608-0-01				147981-0-01		

