

PARTS BOOK
FOR
BROTHER DB2-B763





Semi High Speed Straight Lock Stitch



www.PromElectroAvtomat.ru
BROTHER INDUSTRIES, LTD.

www.PromElectroAvtomat.ru

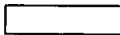

Notes for using this Parts book

1. If the symbol  is found in the "Parts No." column or the "Assembly No." column, refer to the separate parts list on page 7.
2. The symbol  in the "Parts No." column indicates that the part is not available for supply. If, however, there is a number in the "Assembly No." column, the part can be ordered as an assembly. Please, therefore, order by using the Assembly No..
3. This book was prepared based on information available in May, 1978.
4. Parts are subject to changes in design without prior notice.

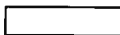

Anmerkungen zum Gebrauch dieses Stücklistebuches

1. Dieses Zeichen  in der Spalte "Parts No. (Teilnummer)" oder "Assembly No. (Gerätesatznummer)" verweist auf die Gesonderte Stückliste auf Seite 7.
2. Dieses Zeichen  in der Spalte "Teilnummer" bedeutet, daß dieser Teil nicht lieferbar ist. Wenn jedoch in der Spalte "Gerätesatznummer" eine Nummer steht, kann dieser Teil als ein Geräteteilsatz bestellt werden. Bestellen Sie daher bitte mit dieser Gerätesatznummer.
3. Dieses Buch basiert auf den Informationen vom Mai, 1978.
4. Modelländerungen sind vorbehalten.

Notes sur l'utilisation de ce manuel de pièces détachées

1. Si le symbole  se trouve dans la colonne "Parts No. (N° de pièce)" ou dans la colonne "Assembly No. (N° jeu de pces)", veuillez vous référer à la liste de pièces annexe page 7.
2. Le symbole  dans la colonne "N° de pièce" signifie que la pièce ne peut être fournie. Si, dans la colonne "N° jeu de pces", il y a un numéro de nomenclature, la pièce peut être commandée comme faisant partie d'un jeu de pièces. Donc, pour toute commande, veuillez spécifier le n° du jeu de pièces.
3. Ce manuel a été fait d'après les renseignements valables au mois de Mai, 1978.
4. Les pièces peuvent être sujettes à des modifications sans préavis.

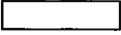
Notas para usar este Libro de Piezas

1. De haber un símbolo  junto al "Parts No. (Número de Pieza)" o en la columna del "Assembly No. (Número de Juego)", habrá que mirar la lista de piezas separada de la página 7.
2. El símbolo , que se encuentra en la columna del "Número de Pieza", quiere decir que no se dispone de dicha pieza sola. Cuando, empero, hay un número en la columna del "Numero de Juego", se podrá ordenar la pieza con todo el juego. Por lo tanto, será mejor hacer el pedido recurriendo al número del juego respectivo.
3. Este libro ha sido compilado basándose en los datos de que se disponía en Mago de 1978.
4. Las piezas quedan sujetas a cambios de diseño sin aviso previo.

CONTENTS

A. Machine Body.....	1
B. Needle Bar, Upper Shaft and Lower Shaft Mechanism.....	2
C. Feed Mechanism.....	3
D. Lubrication and Presser Foot Mechanism	4
Z. Accessories.....	5
SEPARATE PARTS LIST	7
INDEX.....	9

A. Machine Body

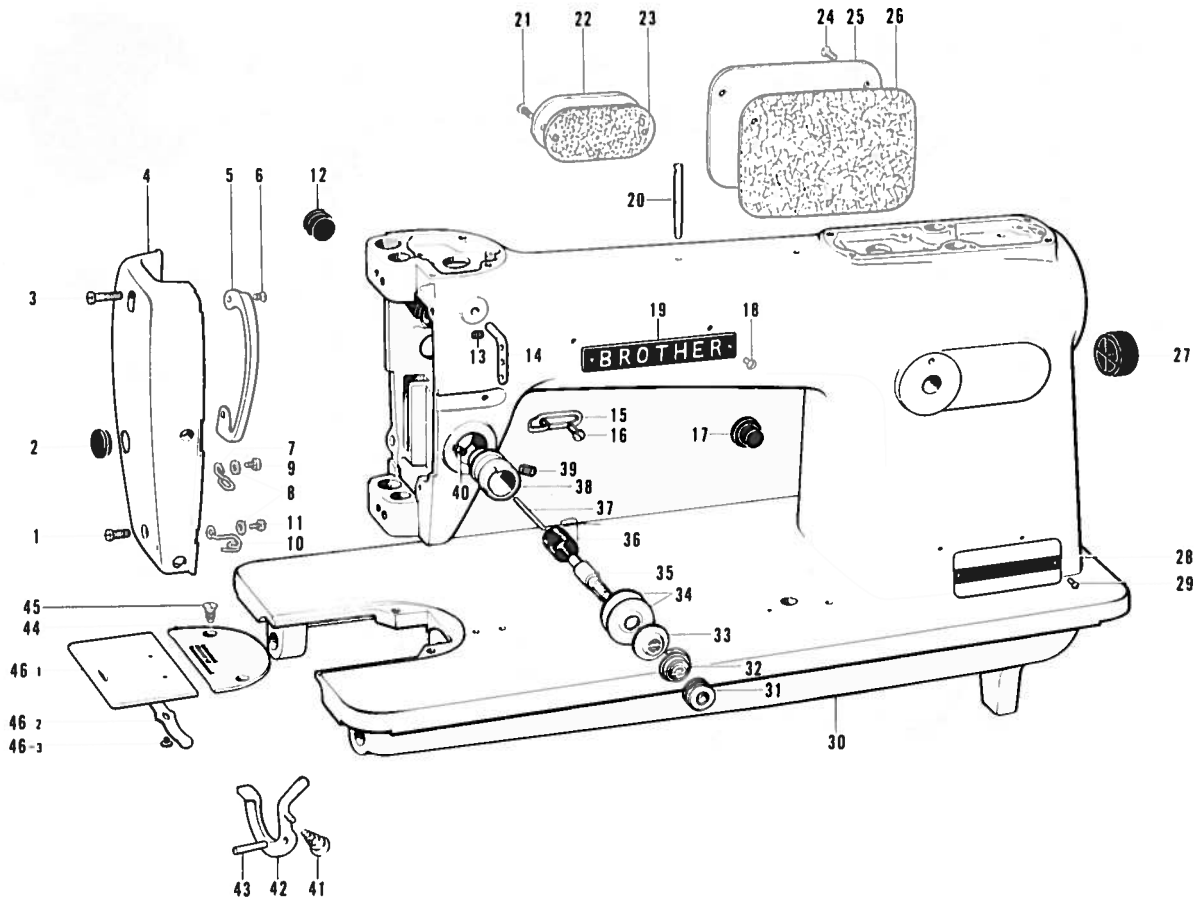

Ref. No.	Name of Parts	Q'ty	Parts No.	Assembly No.	Ref. No.	Name of Parts	Q'ty	Parts No.	Assembly No.
A-1	Screw	1	009671-0-13		A-25	Side Cover	1	116980-0-01	
A-2	Cap	1	115280-0-01		A-26	Packing	1	116981-0-00	
A-3	Screw	1	009671-4-13		A-27	Oil Cap	1	104451-0-01	
A-4	Face Plate	1	116997-0-01		A-28	Model Plate	1		
A-5	Thread Tack-up Cover	1	117185-0-01		A-29	Pin	2		
A-6	Screw	2	403459-0-01		A-30	Arm Bed	1		
A-7	Thread Guide Upper	1	116963-0-01		A-31	Nut	1	100136-0-01	
A-8	Washer	2	025630-2-32		A-32	Tension Spring	1	100401-0-01	
A-9	Screw	1	009630-6-12		A-33	Tension Disc Washer	1	100134-0-01	
A-10	Face Plate Thread Guide Lower	1	116964-0-01		A-34	Tension Disc	2	145446-0-01	
A-11	Screw	1	009630-6-12		A-35	Tension Stud	1	100398-0-01	
A-12	Oil Cap	1	104449-0-01		A-36	Thread Tack-up Spring	1	100399-0-01	
A-13	Screw	1	013680-6-12		A-37	Tension Release Pin	1	100537-0-00	
A-14	Thread Retainer	1	114931-0-01		A-38	Screw	1	103950-0-02	
A-15	Arm Thread Guide	1	113316-0-01		A-39	Tension Bracket	1	145250-0-01	
A-16	Screw	1	009670-6-14		A-40	Screw	1	100402-0-04	
A-17	Oil Cap	1	104821-0-01		A-41	Tension Release Lever Spring	1	100405-0-01	
A-18	Screw	2			A-42	Tension Release Lever	1	113547-0-01	
A-19	Name Plate "BROTHER"	1			A-43	Taper Pin	1	100404-0-00	
A-20	Spool Pin	1	100386-0-01		A-44	Needle Plate	1		
A-21	Screw	2	102538-0-06		A-45	Screw	2	100032-0-03	
A-22	Rear Cover	1	117672-0-01		A-46-1	Slide Plate	1		
A-23	Packing	1	117673-0-00		A-46-2	Slide Plate Spring	1	114561-0-01	
A-24	Screw	3	102538-0-06		A-46-3	Screw	2	122771-0-01	
									A-46 Slide Plate Assembly 118289-0-01

B. Needle Bar, Upper shaft and Lower shaft Mechanism

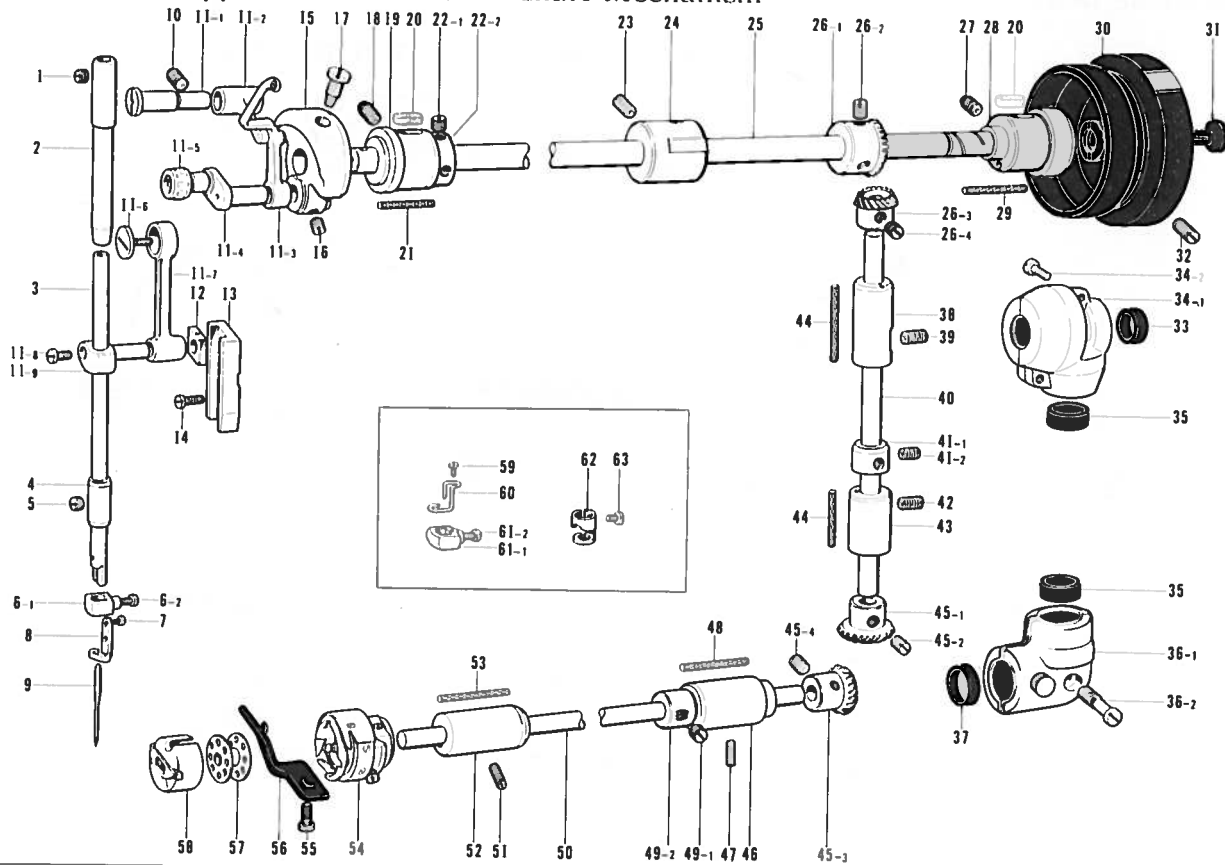

Ref. No.	Name of Parts	Q'ty	Parts No.	Assembly No.	Ref. No.	Name of Parts	Q'ty	Parts No.	Assembly No.
B-1	Screw	1	100260-0-01		B-33	Oil Seal Right	1	103738-0-01	
B-2	Needle Bar Bushing Upper	1			B-34-1	Bevel Gear Case Upper	1		B-34 Bevel Gear Case Upper Assembly 140384-0-01
B-3	Needle Bar	1			B-34-2	Screw	2	100320-0-02	
B-4	Needle Bar Bushing Lower	1			B-35	Seal	2	103796-0-01	
B-5	Screw	1	100260-0-01		B-36-1	Bevel Gear Case Lower	1		B-36 Lower Gear Case D Assembly 118298-0-01
B-6-1	Needle Clamp	1		B-6 Needle Clamp Assembly	B-36-2	Screw	1	100343-0-01	
B-6-2	Screw	1	118521-0-01		B-37	Oil Seal	1	103797-0-01	
B-7	Screw	1			B-38	Vertical Shaft Upper Bushing	1	146363-0-00	
B-8	Needle Bar Thread Guide	1			B-39	Screw	1	013760-6-10	
B-9	Needle	1			B-40	Vertical Shaft	1	144555-0-01	
B-10	Screw	1	013761-0-10		B-41-1	Set Collar	1		B-41 Vertical Shaft Collar Assembly 118759-0-01
B-11-1	Stud for Thread Tack-up Supporter	1		B-11 Needle Bar Connecting Rod Assembly	B-41-2	Screw	2	101706-0-01	
B-11-2	Link Tack-up Supporter	1			B-42	Screw	1	013761-4-10	
B-11-3	Thread Tack-up Lever	1			B-43	Vertical Shaft Lower Bushing	1	146364-0-00	
B-11-4	Needle Bar Crank	1			B-44	Wick	2	114240-0-01	
B-11-5	Needle Roller Bearing	1			B-45-1	Gear	1		B-45 Lower Shaft Gear Assembly 118296-0-01
B-11-6	Screw	1	145465-0-01		B-45-2	Screw	2	013770-7-10	
B-11-7	Needle Bar Crank Rod	1			B-45-3	Gear	1		
B-11-8	Screw	1	140004-0-01		B-45-4	Screw	2	013770-7-10	
B-11-9	Needle Bar Clamp	1			B-46	Lower Shaft Bushing Right	1	144559-0-00	
B-12	Needle Bar Guide Slide Brock	1	102630-0-01		B-47	Screw	1	011681-2-12	
B-13	Needle Bar Guide	1	116950-0-00		B-48	Wick	1	118450-0-01	
B-14	Screw	2	009670-6-12		B-49-1	Screw	2	101706-0-03	B-49 Set Collar Assembly 118299-0-01
B-15	Thread Tack-up Crank	1			B-49-2	Set Collar	1		
B-16	Screw	2	013770-7-10		B-50	Lower Shaft	1	100351-0-01	
B-17	Screw	1	104464-0-01		B-51	Screw	1	011681-2-12	
B-18	Screw	1	013761-4-10		B-52	Lower Bushing Left	1	144538-0-00	
B-19	Upper Shaft Bushing Left	1	144552-0-00		B-53	Wick	1	117007-0-01	
B-20	Felt	2	100248-0-01		B-54	Rotary Hook	1		
B-21	Wick	1	108808-0-01		B-55	Screw	1	009681-0-12	
B-22-1	Screw	2	013770-7-10	B-22 Pulley Bush Assembly 118371-0-01	B-56	Bobbin Case Holder Position Bracket	1	100367-0-01	
B-22-1	Collar	1			B-57	Bobbin	1	117132-0-01	
B-23	Screw	1	013761-4-10		B-58	Bobbin Case	1	100369-0-01	
B-24	Upper Shaft Bushing Middle	1	116947-0-00		B-59	Screw	1		
B-25	Upper Shaft	1	144551-0-01		B-60	Needle Bar Thread Guide	1		
B-26-1	Gear	1		B-26 Gear Assembly 140378-0-01	B-61-1	Needle Clamp	1		B-61 Needle Clamp Assembly
B-26-2	Screw	2	013770-7-10		B-61-2	Screw	1	114928-0-01	
B-26-3	Gear	1			B-62	Needle Bar Thread Guide	1		
B-26-4	Screw	2	013770-7-10		B-63	Screw	1		
B-27	Screw	1	013760-6-10						
B-28	Upper Shaft Bushing Right	1	144554-0-00						
B-29	Wick	1	108808-0-01						
B-30	Pulley	1							
B-31	Screw	1	104478-0-01						
B-32	Screw	2	013761-4-10						

C. Feed Mechanism

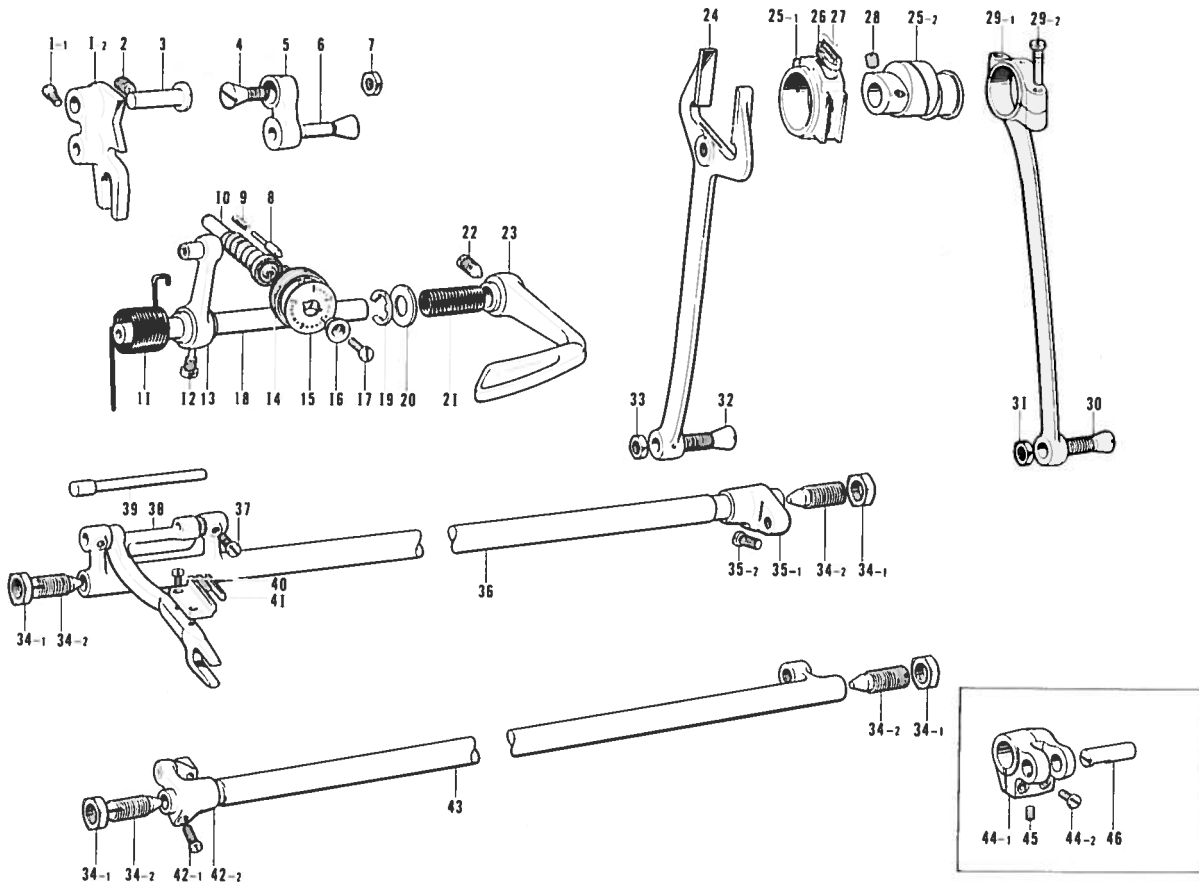

Ref. No.	Name of Parts	Q'ty	Parts No.	Assembly No.	Ref. No.	Name of Parts	Q'ty	Parts No.	Assembly No.
C-1-1	Screw	1	102627-0-01	C-1 Feed Regulator with Screw	C-30	Screw	1	100310-0-01	
C-1-2	Feed Regulator	1			C-31	Nut	1	104689-0-01	
C-2	Screw	1	013781-0-12		C-32	Screw	1		
C-3	Stud	1	111491-0-01		C-33	Nut	1		
C-4	Screw	1	100310-0-01	C-34-1	Nut	4	100075-0-04	C-34 Center Screw with Nut 180987-0-01	
C-5	Feed Regulator Link	1		C-34-2	Center Screw	4			
C-6	Taper Hinge	1	100312-0-01	C-35-1	Feed Rock Shaft Arm	1		C-35 Feed Rock Shaft Arm with Screw	
C-7	Nut	1	104689-0-01	C-35-2	Screw	1	009681-2-12		
C-8	Pin	1	100327-0-01	C-36	Feed Rock Shaft	1	116992-0-01		
C-9	Spring	1	100328-0-01	C-37	Screw	2	104908-0-01		
C-10	Screw	1	100322-0-01	C-38	Feed Bar	1	116993-0-01		
C-11	Feed Regulator Spring	1	116956-0-01	C-39	Feed Bar Shaft	1	116957-0-01		
C-12	Bolt	1	108749-0-01	C-40	Screw	2	100080-0-03		
C-13	Feed Regu	1	116953-0-01	C-41	Feed Dog	1			
C-14	Length Control Dial	1	142483-0-01	C-42-1	Screw	1	009681-6-12	C-42 Feed Lifting Arm Assembly 181562-0-01	
C-15	Length Control Plate	1	142484-0-01	C-42-2	Feed Lifting Arm	1			
C-16	Washer	1	142746-0-01	C-43	Feed Lifting Rock Shaft	1	116995-0-01		
C-17	Screw	1	142747-0-01	C-44-1	Feed Rock Shaft Arm	1		C-44 Feed Rock Shaft Arm with Screw	
C-18	Feed Regulator Lever Shaft	1	146365-0-01	C-44-2	Screw	2	009681-4-13		
C-19	Stop Ring	1	048080-3-42	C-45	Screw	1			
C-20	Washer	1	025100-1-30	C-46	Feed Rock Shaft Arm Pin	1			
C-21	Collar	1	141190-0-01						
C-22	Screw	1	015771-0-12						
C-23	Reverse Lever	1	108540-0-01						
C-24	Feed Forked Connector	1							
C-25-1	Sleeve	1		C-25 Feed Cam Sleeve Assembly					
C-25-2	Feed Cam	1							
C-26	Felt	1	106442-0-01						
C-27	Felt Wipe	1	106440-0-00						
C-28	Screw	2	013760-8-10						
C-29-1	Crank Rod	1		C-29 Crank Rod Assembly 118293-0-01					
C-29-2	Screw	2	107428-0-01						

D. Lubrication and Presser Foot Mechanism

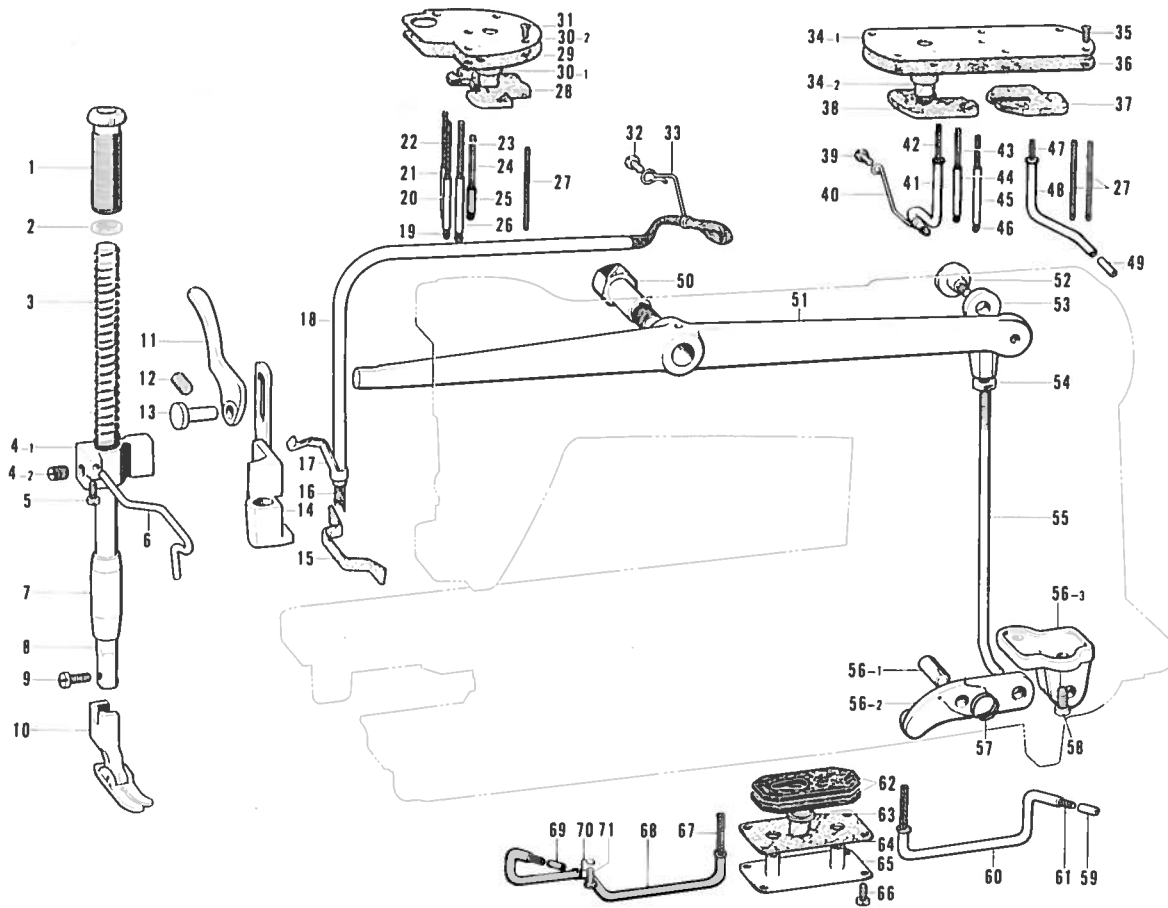

Ref. No.	Name of Parts	Q'ty	Parts No.	Assembly No.	Ref. No.	Name of Parts	Q'ty	Parts No.	Assembly No.
D-1	Screw	1	100279-1-01		D-35	Screw	6	102538-0-06	
D-2	Washer	1	141099-0-01		D-36	Packing	1	116979-0-01	
D-3	Presser Spring	1	144748-0-01		D-37	Felt A	1	117009-0-01	
D-4.1	Presser Bar Clamp	1		D-38	Felt B	1	117010-0-01		
D-4.2	Screw	1	013760-8-10	D-39	Screw	1	001670-6-12		
D-5	Screw	1	140553-0-01	D-40	Tube Stopper	1	116975-0-01		
D-6	Thread Guide	1	117178-0-01	D-41	Vinyl Tube	1	116976-0-00		
D-7	Presser Bar Bushing	1	111467-0-01	D-42	Wick	1	108802-0-01		
D-8	Presser Bar	1	103013-0-01	D-43	Wick	1	117007-0-01		
D-9	Screw	1	001670-8-14	D-44	Oil Pipe	1	116967-0-00		
D-10	Presser Foot	1		D-45	Oil Pipe	1	116970-0-00		
D-11	Presser Foot Lifter	1	142481-0-01	D-46	Wick	1	117007-0-01		
D-12	Screw	1	013760-6-12	D-47	Wick	1	109405-0-01		
D-13	Presser Foot Lifter Stud	1	109801-0-01	D-48	Vinyl Tube	1	117179-0-00		
D-14	Presser Foot Lifter Bracket	1	100498-0-01	D-49	Oil Pipe	1	116968-0-00		
D-15	Packing	1	117024-0-00	D-50	Screw	1	102921-0-02		
D-16	Wick	1	140439-0-01	D-51	Knee Lifter Lever	1	116990-0-01		
D-17	Vinyl Tube Holder	1	140437-0-01	D-52	Screw	1	100299-0-01		
D-18	Vinyl Tube	1	117021-0-00	D-53	Knee Lifter Joint	1	100298-0-01		
D-19	Wick	1	109405-0-01	D-54	Nut	1	110161-0-03		
D-20	Oil Pipe	1	116966-0-00	D-55	Knee Lifter Connecting Rod	1	100300-0-01		
D-21	Oil Pipe	1	116967-0-00	D-56.1	Pin	1	118550-0-00		
D-22	Wick	1	117007-0-01	D-56.2	Lever Pawl	1	143869-0-01	D-56 Lever Pawl Assembly 143868-0-01	
D-23	Wick	1	109405-0-01	D-56.3	Lever Pawl Support	1			
D-24	Wick	1	117006-0-01	D-57	Spring	1	100304-0-01		
D-25	Oil Pipe	1	116966-0-00	D-58	Screw	2	009710-8-12		
D-26	Oil Pipe	1	116969-0-00	D-59	Oil Pipe	1	116968-0-00		
D-27	Wick	3	108805-0-01	D-60	Vinyl Tube	1	116984-0-00		
D-28	Felt	1	117008-0-01	D-61	Wick	1	117012-0-01		
D-29	Packing	1	116974-0-01	D-62	Bed Oil Reserver Felt	2	117013-0-01		
D-30.1	Oil Reserver Window Right Arm	1	116973-0-01	D-63	Bed Oil Window	1	116987-0-01		
D-30.2	Oil Reserver Cover Right Arm	1		D-64	Packing	1	116986-0-01		
D-31	Screw	4	102528-0-06	D-65	Bed Oil Reserver	1	116985-0-01		
D-32	Screw	1	009670-6-13	D-66	Screw	4	009670-8-13		
D-33	Oil Wick Supporter	1	142100-0-01	D-67	Wick	1	117011-0-01		
D-34.1	Oil Reserver Window Right Arm	1	116973-0-01	D-68	Vinyl Tube	1	116983-0-00		
D-34.2	Oil Reserver Right Arm	1		D-69	Oil Pipe	1	116968-0-00		
				D-70	Wick Holder	1	112745-0-01		
				D-71	Screw	1	009670-5-12		

Z. Accessories

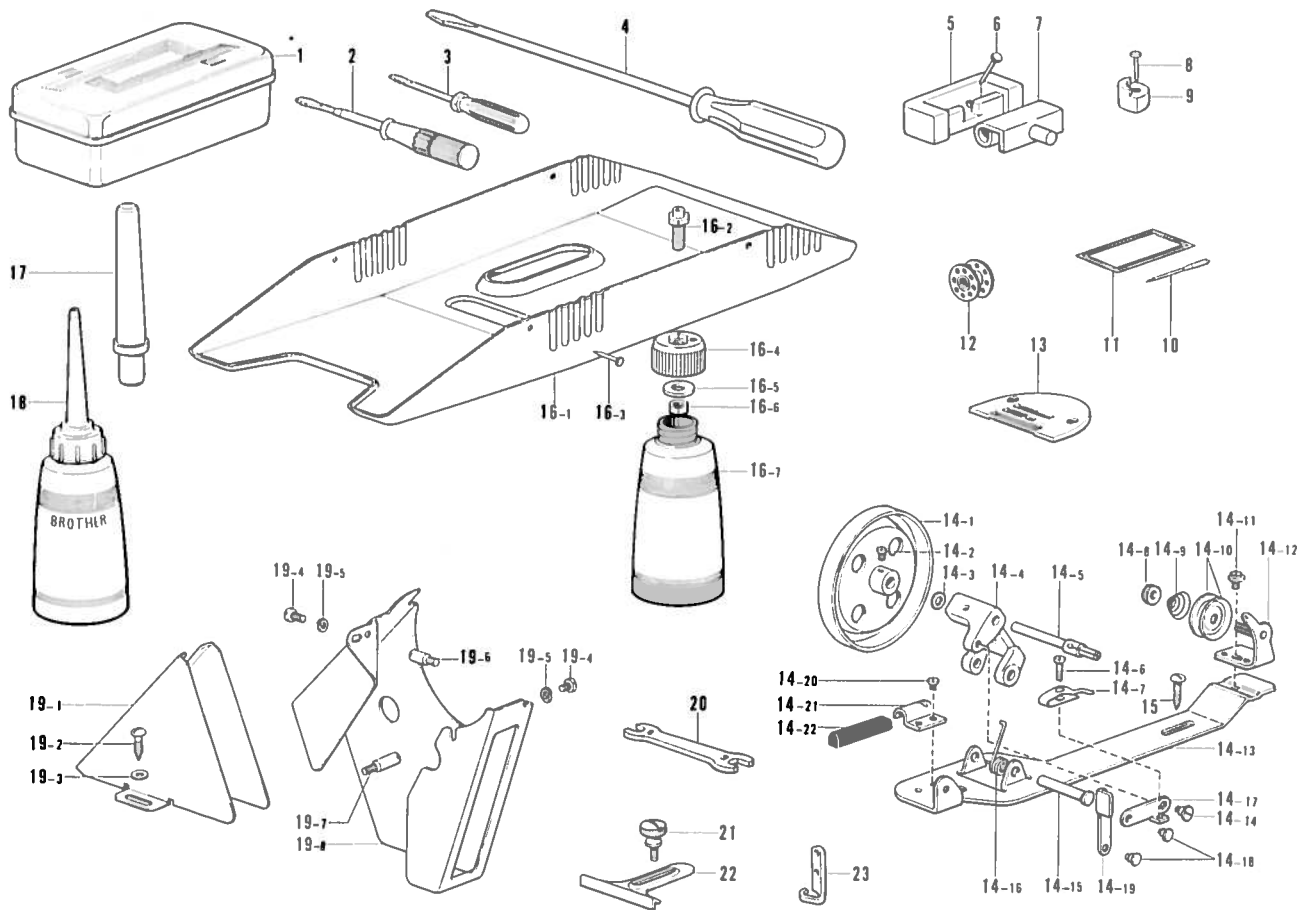

Ref. No.	Name of Parts	Q'ty	Parts No.	Assembly No.	Ref. No.	Name of Parts	Q'ty	Parts No.	Assembly No.
Z- 1	Accessory Box		110436-0-01		Z-14-15	Pin			Z-14 Bobbin Winder Assembly 117963-0-01
Z- 2	Screw Driver		118837-0-01		Z-14-16	Spring		117969-0-01	
Z- 3	Screw Driver		142443-0-01		Z-14-17	Bobbin Presser Arm			
Z- 4	Screw Driver		101572-1-01		Z-14-18	Pin		100661-0-01	
Z- 5	Rubber Hinge		143910-0-01		Z-14-19	Bobbin Presser Arm Bracket			
Z- 6	Nail		109714-0-00		Z-14-20	Screw		009679-3-12	
Z- 7	Hinge		143882-0-01		Z-14-21	Bobbin Winder Wheel Stopper Holder			
Z- 8	Nail		109714-0-00		Z-14-22	Bobbin Winder Wheel Stopper		100662-0-01	
Z- 9	Head Cushion		148890-1-01		Z-15	Screw		100666-0-02	
Z-10	Needle				Z-16- 1	Oil Pan			Z-16 Oil Pan Assembly 117447-0-01
Z-11	Needle Bag				Z-16- 2	Oil Hole		144507-0-00	
Z-12	Bobbin		117132-0-01		Z-16- 3	Nail		109714-0-00	
Z-13	Needle Plate				Z-16- 4	Cap		144508-0-01	
Z-14- 1	Bobbin Winder Wheel Assembly				Z-16- 5	Washer		025080-2-32	
Z-14- 2	Screw		100366-0-02		Z-16- 6	Nut		021080-3-06	
Z-14- 3	Washer				Z-16- 7	Oiler		114486-0-01	
Z-14- 4	Bobbin Winder Wheel Shaft Bushing				Z-17	Head Rest		100477-0-01	
Z-14- 5	Bobbin Winder Shaft		117970-0-01		Z-18	Oiler		114483-0-01	
Z-14- 6	Screw		100657-0-01	Z-14 Bobbin Winder Assembly 117963-0-01	Z-19- 1	Belt Cover D			Z-19 Belt Cover Assembly
Z-14- 7	Bobbin Presser				Z-19- 2	Screw		100666-0-02	
Z-14- 8	Nut				Z-19- 3	Washer		025750-1-32	
Z-14- 9	Spring		100401-0-01		Z-19- 4	Screw		009680-8-12	
Z-14-10	Tension Disc		145446-0-01		Z-19- 5	Washer		028680-2-42	
Z-14-11	Screw				Z-19- 6	Stud		147856-0-01	
Z-14-12	Bobbin Winder Wheel Guide Bracket Assembly				Z-19- 7	Stud		147855-0-01	
Z-14-13	Bobbin Winder Wheel Bracket				Z-19- 8	Belt Cover UA			
Z-14-14	Screw		100659-0-01		Z-20	Spanner			
					Z-21	Ruler			
					Z-22	Thumb Screw			
					Z-23	Needle Bar Thread Guide			

* The details of included accessories are subject to change.

* Änderungen in der Aufstellung der mitgelieferten Zubehöre sind vorbehalten.

* Les détails des accessoires inclus sont sujets à des changements.

* Los detalles de los accesorios incluidos pueden variar.

www.PromElectroAvtomat.ru

Z. Accessories

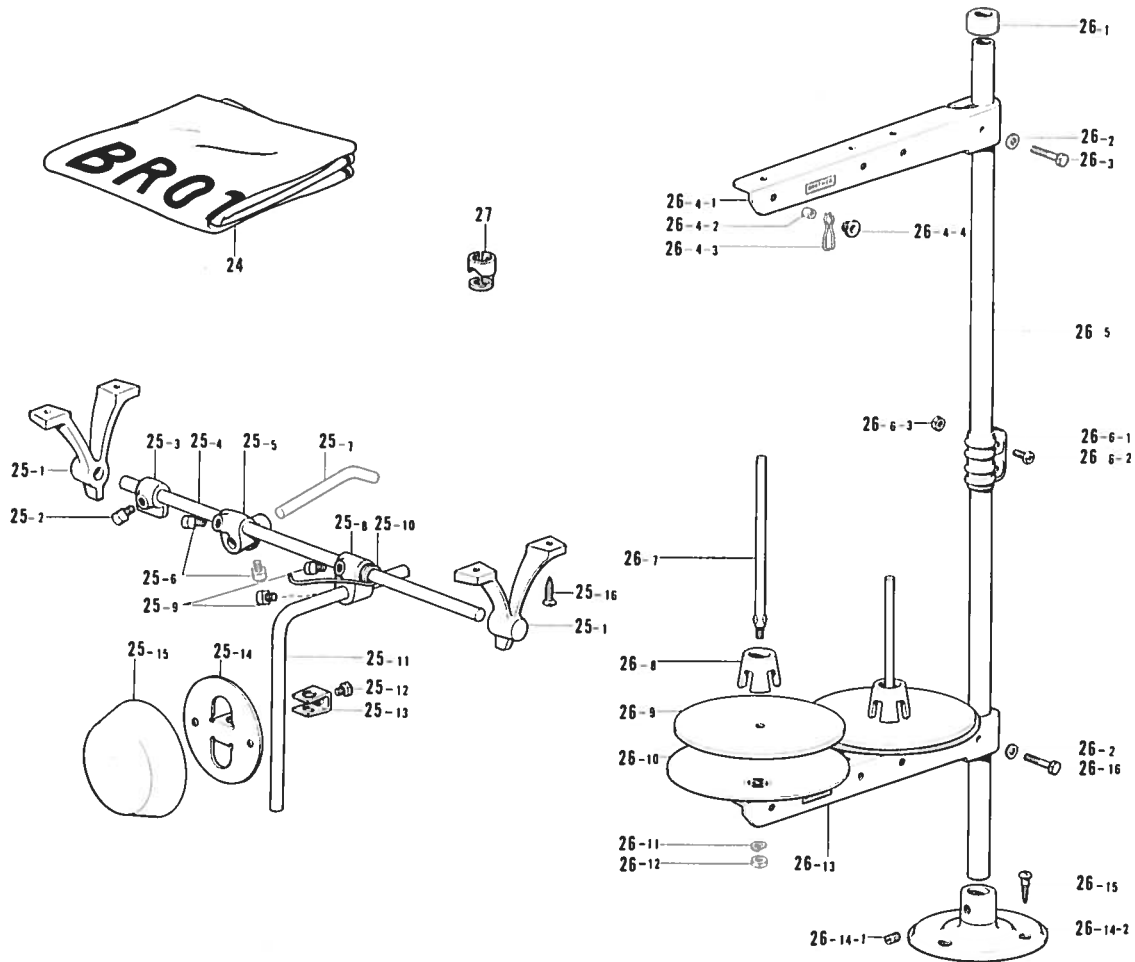

Ref. No.	Name of Parts	Qty	Parts No.	Assembly No.	Ref. No.	Name of Parts	Qty	Parts No.	Assembly No.	
Z-24	Head Cover		144222-0-01		Z-26-4-1	Spool Holder			Z-26-4	
Z-25-1	Knee Lifter Shaft Bracket			Z-25 Knee Lifter Assembly	Z-26-4-2	Thread Bushing		142990-0-01	Z-26-4 Thread Hanger Assembly	
Z-25-2	Bolt		100463-0-01		Z-26-4-3	Thread Guide Spring		150184-0-01		150192-0-01
Z-25-3	Stopper Collar				Z-26-4-4	Thread Hanger		150183-0-00		
Z-25-4	Knee Lifter Shaft				Z-26-5	Pipe		150172-0-01		
Z-25-5	Knee Lifter Crank Presser Bar Connector				Z-26-6-1	Joint			Z-26-6 Joint Assembly	
Z-25-6	Bolt		100463-0-01		Z-26-6-2	Screw		150202-0-01		150106-0-01
Z-25-7	Knee Lifter Crank Presser Bar				Z-26-6-3	Nut		021500-1-03		
Z-25-8	Knee Lifter Joint				Z-26-7	Spool Shaft		150179-0-01	Z-26 Cotton Stand Assembly	
Z-25-9	Bolt		100463-0-01		Z-26-8	Spool Cushion		147060-0-01		
Z-25-10	Spring				Z-26-9	Spool Mat		150182-0-00		
Z-25-11	Knee Lifter Bar		104619-0-02		Z-26-10	Spool Stand Base		150180-0-00		
Z-25-12	Bolt		110087-0-01		Z-26-11	Spring Washer		028050-2-43	150150-0-01	
Z-25-13	Knee Lifter Plate Stopper		114967-0-01		Z-26-12	Nut		021500-1-03		
Z-25-14	Knee Lifter Plate		114966-0-01		Z-26-13	Spool Holder Assembly		150177-0-01		
Z-25-15	Knee Lifter Cover		140503-0-01		Z-26-14-1	Screw		150181-0-01	Z-26-14 Cotton Stand Base Assembly	
Z-25-16	Screw		100460-0-00		Z-26-14-2	Cotton Stand Base				150139-0-01
Z-26-1	Cap		150174-0-00	Z-26-15	Screw		031452-2-03			
Z-26-2	Washer		025050-2-33	Z-26-16	Screw		017502-8-03			
Z-26-3	Screw		017502-8-03	Z-27	Needle Bar Thread Guide					
				Z-26 Cotton Stand Assembly 150150-0-01						

* The details of included accessories are subject to change.

* Änderungen in der Aufstellung der mitgelieferten Zubehöre sind vorbehalten.

* Les détails des accessoires inclus sont sujets à des changements.

* Los detalles de los accesorios incluidos pueden variar.

www.PromElectroAvtomat.ru

SEPARATE PARTS LIST

Ref. No.	Name of Parts	Sub-Class	-3				
		Destination	-1				England
A-44	Needle Plate	100603-0-01		100266-0-01			111241-0-01
B- 2	Needle Bar Bushing Upper	117004-0-01		117004-0-01			
B- 3	Needle Bar	117121-0-01		106408-0-01			109356-0-01
B- 4	Needle Bar Bushing Lower	109206-0-01		109206-0-01			
B- 6	Needle Clamp Assembly			143930-0-01			
B- 7	Screw			009630-4-12			
B- 8	Needle Bar Thread Guide			144577-0-01			
B- 9	Needle	100575-0-11		100265-0-14			100265-0-21
B-11	Needle Bar Connecting Rod Assembly	117119-0-01		117003-0-01			
B-11-9	Needle Bar Clamp	104463-0-01		104463-0-01			
B-15	Thread Tack-up Crank	142405-0-00		142097-0-00			
B-30	Pulley	117525-0-01		117525-0-01			
B-51	Rotary Hook	116996-0-01		116996-0-01			
B-59	Screw						
B-60	Needle Bar Thread Guide						
B-61	Needle Clamp Assembly						
B-62	Needle Bar Thread Guide	117123-0-01					
B-63	Screw	140553-0-01					
C- 1	Feed Regulator with Screw	182334-0-01		182349-0-01			
C- 5	Feed Regulator Link	104897-0-01		104897-0-00			
C-24	Feed Froked Connector	116991-0-01		116991-0-01			
C-25	Feed Cam Sleeve Assembly	118300-0-01		180435-0-01			
C-32	Screw	100310-0-01		100310-0-01			
C-33	Nut	104689-0-01		104689-0-01			
C-35	Feed Rock Shaft Arm with Screw	118292-0-01		118292-0-01			
C-41	Feed Dog	111898-0-01		100334-0-01			
C-44	Feed Rock Shaft Arm with Screw						
C-45	Screw						
C-46	Feed Rock Shaft Arm Pin						
D-10	Presser Foot	111856-0-01		113280-0-01			
Z-10	Needle	100575-0-11		100265-0-14			100265-0-21
Z-13	Needle Plate	100603-0-01	100266-0-01	100267-0-01			111241-0-01
Z-19	Belt Cover Assembly						147895-0-11
Z-20	Spanner	100887-0-01		100887-0-01			
Z-21	Ruler	100471-0-01		100471-0-01			
Z-22	Thumb Screw	106120-0-01		106120-0-01			
Z-23	Thread Guide			144577-0-01			
Z-25	Knee Lifter Assembly	110845-0-01		110845-0-01			
Z-26	Cotton Stand Assembly			150150-0-01			150150-0-01
Z-27	Needle Bar Thread Guide	117123-0-01					

Ref. No.	Name of Parts	Sub-Class					Fromosa
		Destination					
		-5					
A-44	Needle Plate	118107-0-01					
B- 2	Needle Bar Bushing Upper	117116-0-01					111463-0-01
B- 3	Needle Bar	117252-0-01					145268-0-01
B- 4	Needle Bar Bushing Lower	117117-0-01					145760-0-01
B- 6	Needle Clamp Assembly	/	/	/	/	/	/
B- 7	Screw	/	/	/	/	/	/
B- 8	Needle Bar Thread Guide	/	/	/	/	/	/
B- 9	Needle	100265-0-19					
B-11	Needle Bar Connecting Rod Assembly	117114-0-01					142675-0-01
B-11-9	Needle Bar Clamp	111237-0-01					
B-15	Thread Tack-up Crank	142406-0-00					
B-30	Pulley	115246-0-01					
B-54	Rotary Hook	111272-0-01					
B-59	Screw	140530-0-01					/
B-60	Needle Bar Thread Guide	118382-0-01					/
B-61	Needle Clamp Assembly	180166-0-01					/
B-62	Needle Bar Thread Guide	/	/	/	/	/	112775-0-01
B-63	Screw	/	/	/	/	/	140553-0-01
C- 1	Feed Regulator with Screw	182352-0-01					181127-0-01
C- 5	Feed Regulator Link	104897-0-01					
C-24	Feed Froked Connector	109147-0-01					
C-25	Feed Cam Sleeve Assembly	180435-0-01					
C-32	Screw	/	/	/	/	/	/
C-33	Nut	/	/	/	/	/	/
C-35	Feed Rock Shaft Arm with Screw	/	/	/	/	/	/
C-41	Feed Dog	117775-0-01					
C-44	Feed Rock Shaft Arm with Screw	144563-0-01					
C-45	Screw	013680-6-12					
C-46	Feed Rock Shaft Arm Pin	109153-0-01					
D-10	Presser Foot	113280-0-01					
Z-10	Needle	100265-0-19					
Z-13	Needle Plate	118108-0-01					
Z-19	Belt Cover Assembly	/	/	/	147895-0-11	/	/
Z-20	Spanner	100887-0-01					/
Z-21	Ruler	100471-0-01					/
Z-22	Thumb Screw	106120-0-01					/
Z-23	Thread Guide	/	/	/	/	/	/
Z-25	Knee Lifter Assembly	110845-0-01					
Z-26	Cotton Stand Assembly	/	150150-0-01	/	150150-0-01	/	/
Z-27	Needle Bar Thread Guide	/	/	/	/	/	/

INDEX

Parts No.	Ref. No.	Remark	Parts No.	Ref. No.	Remark	Parts No.	Ref. No.	Remark	Parts No.	Ref. No.	Remark
001670-6-12	D-39		100267-0-01	Z-13		104897-0-00	C-5		116971-0-01	D-30	
001670-8-11	D-9		100279-1-01	D-1		104897-0-01	C-5		116973-0-01	D-30-1	
009630-4-12	B-7		100298-0-01	D-53		101908-0-01	C-37			D-34-1	
009630-6-12	A-9		100299-0-01	D-52		106120-0-01	Z-22		116974-0-01	D-29	
	A-11		100300-0-01	D-55		106408-0-01	B-3		116975-0-01	D-40	
009670-5-12	D-71		100304-0-01	D-57		106410-0-00	C-27		116976-0-01	D-41	
009670-6-12	B-11		100310-0-01	C-4		106412-0-01	C-26		116977-0-01	D-34	
009670-6-13	D-32			C-30		107128-0-01	C-29-2		116979-0-01	D-36	
009670-6-14	A-16			C-32		108510-0-01	C-23		116980-0-01	A-25	
009670-8-13	D-66		100312-0-01	C-6		108719-0-01	C-12		116981-0-00	A-26	
009671-0-13	A-1		100320-0-02	B-34-2		108802-0-01	D-42		116983-0-00	D-68	
009671-4-13	A-3		100322-0-01	C-10		108805-0-01	D-27		116984-0-00	D-60	
009679-3-12	Z-14-20		100327-0-01	C-8		108808-0-01	B-21		116985-0-01	D-65	
009680-8-12	Z-19-4		100328-0-01	C-9			B-29		116986-0-01	D-64	
009681-0-12	B-55		100334-0-01	C-41		108880-0-01	B-11-2		116987-0-01	D-63	
009681-2-12	C-35-2		100343-0-01	B-36-2		109147-0-01	C-24		116990-0-01	D-51	
009681-4-13	C-41-2		100351-0-01	B-50		109153-0-01	C-46		116991-0-01	C-24	
009681-6-12	C-42-1		100366-0-02	Z-14-2		109206-0-01	B-4		116992-0-01	C-36	
009710-8-12	D-58		100367-0-01	B-56		109356-0-01	B-3		116993-0-01	C-38	
011681-2-12	B-47		100369-0-01	B-58		109405-0-01	D-19		116995-0-01	C-43	
	B-51		100386-0-01	A-20			D-23		116996-0-01	B-54	
013680-6-12	A-13		100398-0-01	A-35			D-47		116997-0-01	A-4	
	C-45		100399-0-01	A-36		109714-0-00	Z-6		117003-0-01	B-11	
013760-6-10	B-27		100401-0-01	A-32			Z-8		117004-0-01	B-2	
	B-39			Z-14-9			Z-16-3		117006-0-01	D-24	
013760-6-12	D-12		100402-0-01	A-40		109801-0-01	D-13		117007-0-01	B-53	
013760-8-10	C-28		100404-0-00	A-43		110087-0-01	Z-25-12			D-22	
	D-1-2		100405-0-01	A-41		110161-0-03	D-54			D-43	
013761-0-10	B-10		100460-0-00	Z-25-16		110436-0-01	Z-1			D-46	
013761-4-10	B-18		100463-0-01	Z-25-2		110845-0-01	Z-25		117008-0-01	D-28	
	B-23			Z-25-6		111237-0-01	B-11-9		117009-0-01	D-37	
	B-32			Z-25-9		111241-0-01	A-44		117010-0-01	D-38	
	B-42		100471-0-01	Z-21			Z-13		117011-0-01	D-67	
013770-7-10	B-16		100477-0-01	Z-17		111272-0-01	B-54		117012-0-01	D-61	
	B-22-1		100498-0-01	D-14		111463-0-01	B-2		117013-0-01	D-61	
	B-26-2		100537-0-00	A-37		111467-0-01	D-7		117021-0-00	D-18	
	B-26-4		100575-0-11	Z-10		111491-0-01	C-3		117024-0-00	D-15	
	B-45-2		100603-0-01	Z-13		111856-0-01	D-10		117114-0-01	B-11	
	B-45-4		100657-0-01	Z-14-6		111898-0-01	C-41		117116-0-01	B-2	
013781-0-12	C-2		100659-0-01	Z-14-14		112745-0-01	D-70		117117-0-01	B-4	
015771-0-12	C-22		100661-0-01	Z-14-18		112775-0-01	B-62		117119-0-01	B-11	
017502-8-03	Z-26-3		100662-0-01	Z-14-22		113280-0-01	D-10		117121-0-01	B-3	
021080-3-06	Z-16-6		100666-0-02	Z-15		113316-0-01	A-15		117123-0-01	B-62	
021500-1-03	Z-26-6-3			Z-19-2		113547-0-01	A-42			Z-27	
	Z-26-12		100887-0-01	Z-20		114240-0-01	B-44		117132-0-01	B-57	
025050-2-33	Z-26-2		101572-1-01	Z-4		114483-0-01	Z-18			Z-12	
025080-2-32	Z-16-5		101706-0-01	B-41-2		114486-0-01	Z-16-7		117178-0-01	D-6	
025100-1-30	C-20		101706-0-03	B-49-1		114561-0-01	A-46-2		117179-0-00	D-48	
025630-2-32	A-8		102528-0-06	D-31		114928-0-01	B-61-2		117185-0-01	A-5	
025750-1-32	Z-19-3		102538-0-06	A-21		114931-0-01	A-14		117252-0-01	B-3	
028680-2-42	Z-19-5			A-24		114966-0-01	Z-25-14		117447-0-01	Z-16	
028050-2-43	Z-26-11			D-35		114967-0-01	Z-25-13		117525-0-01	B-30	
031452-2-03	Z-26-15		102627-0-01	C-1-1		115246-0-01	B-30		117672-0-01	A-22	
048080-3-42	C-19		102630-0-01	B-12		115280-0-01	A-2		117673-0-00	A-23	
100032-0-03	A-45		102921-0-02	D-50		116947-0-00	B-24		117775-0-01	C-41	
100075-0-04	C-34-1		103013-0-01	D-8		116950-0-00	B-13		117963-0-01	Z-14	
100080-0-03	C-40		103738-0-01	B-33		116953-0-01	C-13		117969-0-01	Z-14-16	
100134-0-01	A-33		103796-0-01	B-35		116956-0-01	C-11		117970-0-01	Z-14-5	
100136-0-01	A-31		103797-0-01	B-37		116957-0-01	C-39		118107-0-01	A-44	
100248-0-01	B-20		103950-0-02	A-38		116963-0-01	A-7		118108-0-01	Z-13	
100260-0-01	B-1		104449-0-01	A-12		116964-0-01	A-10		118289-0-01	A-46	
	B-5		104451-0-01	A-27		116966-0-00	D-20		118290-0-01	D-4	
100265-0-14	B-9		104463-0-01	B-11-9		116967-0-00	D-21		118292-0-01	C-35	
	Z-10		104464-0-01	B-17			D-44		118293-0-01	C-29	
100265-0-19	B-9		104478-0-01	B-31		116968-0-00	D-25		118296-0-01	B-45	
	Z-10		104619-0-02	Z-25-11			D-49		118298-0-01	B-36	
100265-0-21	B-9		104689-0-01	C-7			D-59		118299-0-01	B-49	
	Z-10			C-31			D-69		118300-0-01	C-25	
100266-0-01	A-44			C-33		116969-0-00	D-26		118371-0-01	B-22	
	Z-13		104821-0-01	A-17		116970-0-00	D-45		118382-0-01	B-60	

Parts No.	Ref. No.	Remark	Parts No.	Ref. No.	Remark	Parts No.	Ref. No.	Remark	Parts No.	Ref. No.	Remark
118450-0-01	B-48		150184-0-01	Z-26-4-3							
118521-0-01	B-6-2		150202-0-01	Z-26-6-2							
118550-0-00	D-56-1		180166-0-01	B-61							
118759-0-01	B-41		180435-0-01	C-25							
118837-0-01	Z-2		180987-0-01	C-34							
122771-0-01	A-46-3		181127-0-01	C-1							
140004-0-01	B-11-8		181562-0-01	C-42							
140378-0-01	B-26		182334-0-01	C-1							
140384-0-01	B-31		182319-0-01	C-1							
140437-0-01	D-17		182352-0-01	C-1							
140439-0-01	D-16		403459-0-01	A-6							
140503-0-01	Z-25-15										
140530-0-01	B-59										
140553-0-01	B-63										
	D-5										
141099-0-01	D-2										
141190-0-01	C-21										
142097-0-00	B-15										
142100-0-01	D-33										
142405-0-00	B-15										
142406-0-00	B-15										
142443-0-01	Z-3										
142481-0-01	D-11										
142483-0-01	C-14										
142484-0-01	C-15										
142675-0-01	B-11										
142746-0-01	C-16										
142747-0-01	C-17										
142990-0-01	Z-26-4-2										
143868-0-01	D-56										
143869-0-01	D-56-2										
143882-0-01	Z-7										
143910-0-01	Z-5										
143930-0-01	B-6										
144222-0-01	Z-24										
144507-0-00	Z-16-2										
144508-0-01	Z-16-4										
144551-0-01	B-25										
144552-0-00	B-19										
144554-0-00	B-28										
144555-0-01	B-40										
144558-0-00	B-52										
144559-0-00	B-46										
144563-0-01	C-44										
144577-0-01	B-8										
	Z-23										
144748-0-01	D-3										
145250-0-01	A-39										
145268-0-01	B-3										
145446-0-01	A-34										
	Z-14-10										
145465-0-01	B-11-6										
145760-0-01	B-4										
146363-0-00	B-38										
146364-0-00	B-43										
146365-0-01	C-18										
147060-0-01	Z-26-8										
147855-0-01	Z-19-7										
147856-0-01	Z-19-6										
147895-0-11	Z-19										
148890-1-01	Z-9										
150150-0-01	Z-26										
150172-0-01	Z-26-5										
150174-0-00	Z-26-1										
150177-0-01	Z-26-13										
150179-0-01	Z-26-7										
150180-0-00	Z-26-10										
150181-0-01	Z-26-14-1										
150182-0-00	Z-26-9										
150183-0-00	Z-26-4-4										

www.PromElectroAvtomat.ru

www.PromElectroAvtomat.ru



www.PromElectroAvtomat.ru

117-763
195763-0-02
December, 1978
Printed in Japan