

DB2-B780

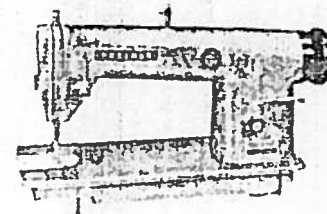

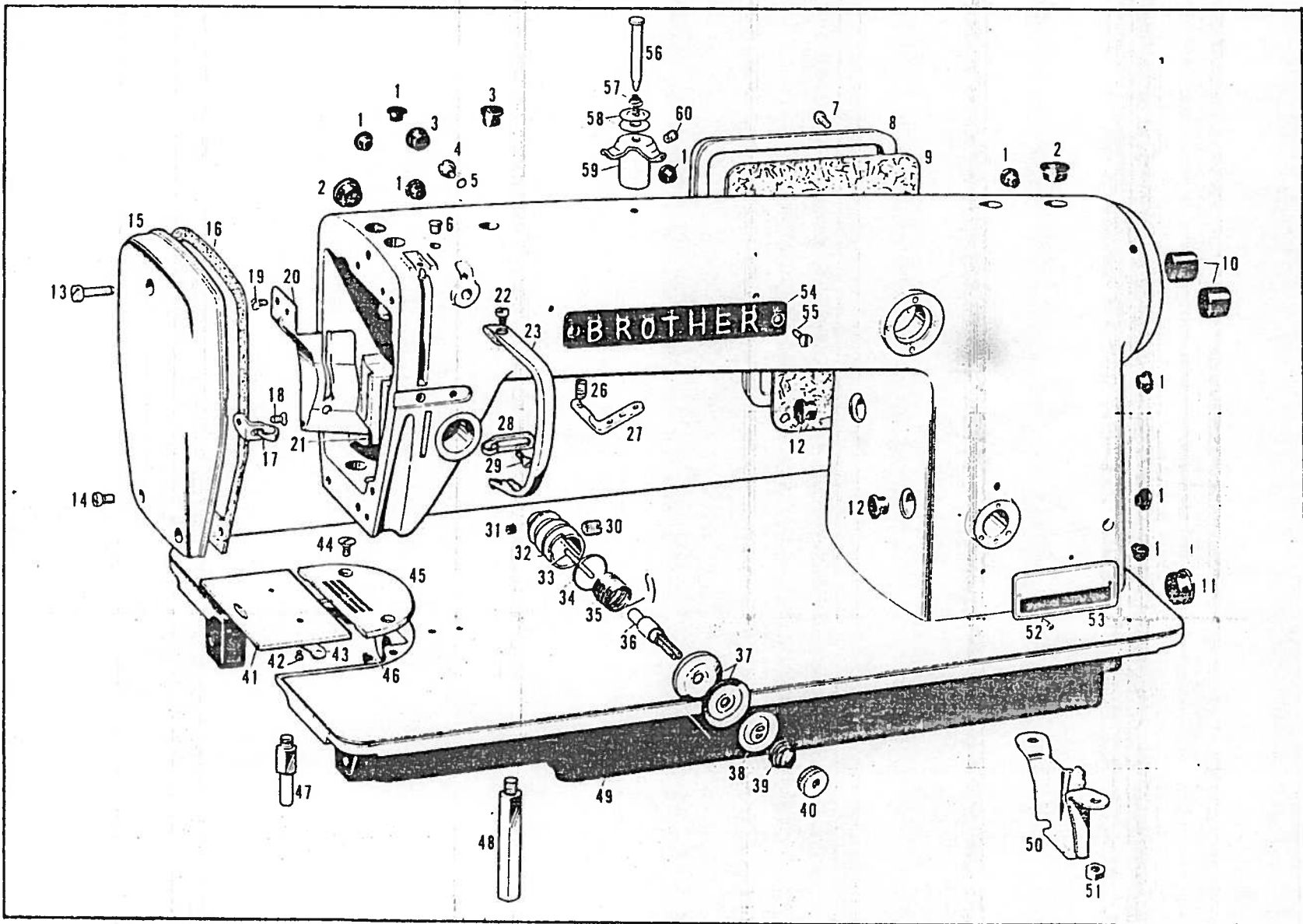

PARTS LIST FOR DB2-B780

B780-A 3

Ref.No.	Name of Parts	Q'ty	Parts-No.	Assembly No.	Ref.No.	Name of Parts	Q'ty	Parts-No.	Assembly No.
A-1	Oil Cap for Hole of B-3, B-41, B-45, B-51, B-56, B-61, B-65	8 pcs.	104450-0-01		A-49	Arm-bed Assembly	1 set.	113384-0-01	
A-2	Oil Cap for Hole of B-40, B-62	2 "	104449-0-01		A-50	Pump Cover	1 pce.	108481-0-03	
A-3	Oil Cap for Hole of A-4, B-63, F-1	2 "	104821-0-01		A-51	Nut for Pump Cover	2 pcs.	100090-0-03	
A-4	Cap Screw on Arm for Oil Hole of B-2	1 pce.	106423-0-01		A-52	Model Plate Pin	2 "	116231-0-01	
A-5	Packing ZN 6227-5 for A-4	1 "	104561-0-01		A-53	Model Plate	1 pce.	110463-0-01	
A-6	Oil Cap	1 "	111865-0-01		A-54	Name Plate	1 "	112547-0-01	
A-7	Set Screw for A-8	1 "	100137-0-02		A-55	Set Screw for A-54	2 pcs.	100191-0-03	
A-8	Rear Cover	1 "	110467-0-01		A-56	Pre-Tension Stud	1 pce.	112939-0-01	
A-9	Packing for A-8	1 "	110547-0-01		A-57	Pre-Tension Spring	1 "	100548-0-01	
A-10	Oil Cap at Inside of Pulley	2 pcs.	104832-0-01		A-58	Pre-Tension Disc	2 pcs.	100546-0-01	
A-11	Oil Cap at Pulley side of Bed	1 pce.	108520-0-01		A-59	Pre-Tension	1 pce.	112938-0-01	129370-0-01
A-12	Oil Cap at Inside of Arm	2 pcs.	104821-0-01		A-60	Set Screw	1 "	100218-0-02	112937-01
A-13	Set Screw for A-15	1 pce.	107385-0-01						
A-14	Set Screw for A-15	2 pcs.	100287-0-04						
A-15	Face Plate	1 pce.	111455-0-01						
A-16	Packing for Face Plate	1 "	109195-0-01						
A-17	Face Plate Thread Guide	1 "	111476-0-01						
A-18	Flat Head Screw for A-17	1 "	108960-0-03						
A-19	Set Screw for A-20	2 pcs.	100242-0-04						
A-20	Oil Stopper Plate for Thread Take-up Link	1 pce.	111478-0-01						
A-21	Wick 4x4 (100)	1 "	109405-0-01						
A-22	Set Screw for A-23	1 "	100541-0-03						
A-23	Thread Take-up Cover	1 "	111477-0-01						
A-26	Set Screw for A-27	1 "	100388-0-04						
A-27	Thread Retainer	1 "	114931-0-01						
A-28	Arm Thread Guide	1 "	113316-0-01						
A-29	Set Screw for A-28	1 "	100257-0-07						
A-30	Set Screw for A-32	1 "	103950-0-02						
A-31	Set Screw for A-36	1 "	100402-0-02						
A-32	Upper Thread Tension Bracket	1 "	111854-0-01						
A-33	Tension Release Pin	1 "	100400-0-00						
A-34	Packing for A-32	1 "	114294-0-01						
A-35	Thread Take-up Spring	1 "	100399-0-01						
A-36	Tension Stud	1 "	100398-0-01						
A-37	Tension Disc	2 pcs.	108721-0-01						
A-38	Tension Disc Washer	1 pce.	100134-0-01						
A-39	Tension Spring	1 "	104525-0-01						
A-40	Tension Control Nut	1 "	100136-0-01						
A-41	Slide Plate	1 "	110471-0-01						
A-42	Slide Plate Spring Screw	2 pcs.	100035-0-01	180100-0-01					
A-43	Slide Plate Spring	1 pce.	100269-0-01						
A-44	Needle Plate Screw	2 pcs.	100032-0-01						
A-45	Needle Plate	1 pce.	110470-0-01						
A-46	Oil Cap on Bed Near Rotary Hook	1 "	104833-0-01						
A-47	Bed Leg B	1 pce.	104830-0-01						
A-48	Bed Leg A	1 "	104829-0-01						

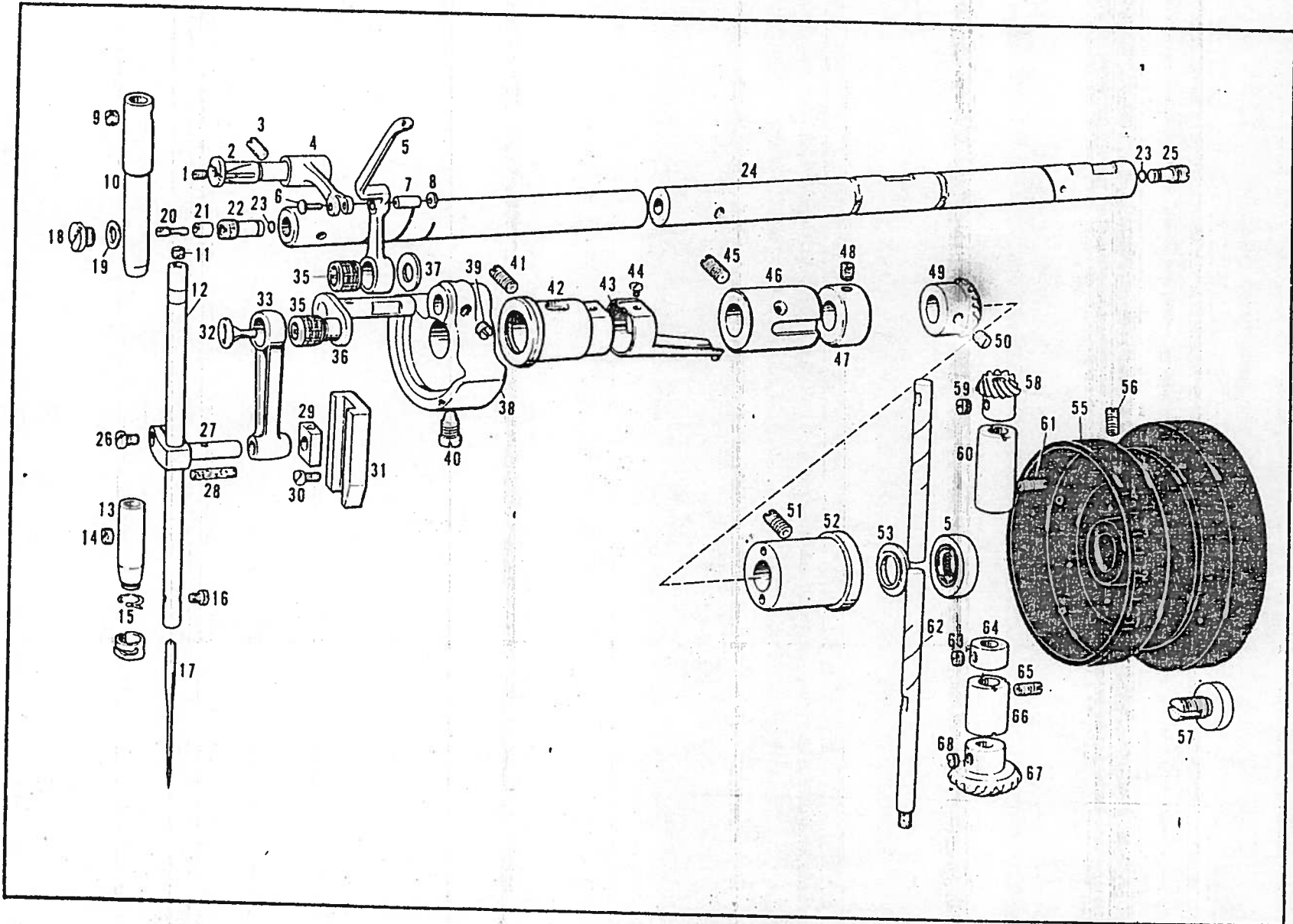

PARTS LIST FOR DB2-B780

B780-B 5

Ref.No.	Name of Parts	Q'ty	Parts No.	Assembly No.	Ref.No.	Name of Parts	Q'ty	Parts-No.	Assembly No.
B-1	Cap Screw for B-2	1 pce.	104651-0-01		B-49	Upper Shaft Gear	1 pce.	116998-0-01	
B-3	Set Screw for B-2	1 "	100016-0-03		B-50	Set Screw for B-49	2 pcs.	100251-0-01	180022-0-01
B-2	Stud for Thread Take-up Supporter	1 "	111468-0-01		B-58	Vertical Shaft Gear	1 "	116999-0-01	
B-4	Thread Take-up Supporter	1 "	111239-0-01		B-59	Set Screw for B-58	2 pcs.	101706-0-01	
B-5	Thread Take-up Lever	1 "	111238-0-01		B-51	Set Screw for B-52	1 pce.	100016-0-03	
B-6	Pin for B-4	1 "	111926-0-00		B-52	Upper Shaft Bearing Right	1 "	104837-0-00	
B-7	Thread Take-up Support Pin	1 "	111240-0-01		B-53	Oil Rejector Right for Upper Shaft	1 "	105670-0-00	
B-8	Washer for B-7	1 "	111920-0-00	113278-0-01	B-54	Oil Seal Right for Upper Shaft	1 "	101187-0-00	
B-26	Clamp Screw for B-27	1 "	100257-0-06		B-55	Arm Pulley	1 "	115245-0-01	
B-27	Needle Bar Connecting Stud	1 "	111237-0-01		B-56	Set Screw for B-55	2 pcs.	100016-0-03	
B-32	Cap Screw for Needle Bar Crank	1 "	103001-0-01		B-57	Cap Screw for B-55	1 pce.	104478-0-01	
B-33	Needle Bar Crank Rod	1 "	111236-0-01		B-60	Vertical Shaft Upper Bushing	1 "	104513-0-00	
B-35	Needle Roller With Retainer	2 pcs.	116735-0-01		B-61	Set Screw for B-60	1 "	100016-0-03	
B-36	Needle Bar Crank	1 pce.	109140-0-01		B-62	Vertical Shaft	1 "	109159-0-01	
B-9	Set Screw for B-10	1 "	100260-0-01		B-63	Set Screw for B-64	2 pcs.	101706-0-01	
B-11	Upper Cap for B-12	1 "	111863-0-01		B-64	Vertical Shaft Collar	2 "	104521-0-01	
B-10	Needle Bar Bushing Upper	1 "	111463-0-01	180033-0-01	B-65	Set Screw for B-66	1 pce.	100016-0-03	
B-12	Needle Bar	1 "	111462-0-01		B-66	Vertical Shaft Lower Bushing	1 "	109208-0-00	
B-13	Needle Bar Bushing Lower	1 "	111464-0-01		B-67	Vertical Shaft Lower Gear C	1 "	117874-0-01	
B-14	Set Screw for B-13	1 "	100260-0-01		B-68	Set Screw for B-67	2 pcs.	100251-0-01	180023-0-01
B-15	Thread Guide under B-13	1 "	100573-0-01		D-40	Lower Shaft Gear	1 pce.	117875-0-01	
B-16	Set Screw for B-17	1 "	100130-0-01	100151-0-01	D-41	Set Screw for D-40	2 pcs.	100251-0-01	
B-17	Needle DBX1	1 "	100265-0-34						
B-18	Oil Cap Screw for Upper Shaft	1 "	104557-0-01						
B-19	Packing for B-18	1 "	104558-0-01						
B-20	Oil Adjusting Screw for B-22	1 "	104570-0-01						
B-21	Vinyl Friction Tube 3x7 for B-20	1 "	104571-0-01	106124-0-01					
B-22	Oil Screw Left for Upper Shaft	1 "	101554-0-00						
B-23	Packing ZNG227-2 for B-22, B-25	2 pcs.	104556-0-01						
B-24	Upper Shaft	1 pce.	110469-0-01						
B-25	Oil Screw Right for Upper Shaft	1 "	104555-0-00						
B-28	Wick 6x16 for Needle Bar Stud	1 "	108309-0-01						
B-29	Needle Bar Guide Slide Block	1 "	102630-0-01						
B-30	Set Screw for B-31	2 pcs.	100137-0-01						
B-31	Needle Bar Guide	1 pce.	102631-0-00						
B-37	Washer for B-36	1 "	110367-0-01						
B-38	Thread Take-up Crank	1 "	109205-0-00						
B-39	Set Screw for B-38	1 "	100251-0-01						
B-40	Set Screw for B-38	2 pcs.	104464-0-01						
B-41	Set Screw for B-42	1 pce.	100016-0-03						
B-42	Upper Shaft Bearing Left	1 "	111459-0-00						
B-43	Oil Flow for B-42	1 "	104552-0-00						
B-44	Set Screw for B-43	1 "	101275-0-03						
B-45	Set Screw for B-46	1 "	100016-0-03						
B-46	Upper Shaft Bearing Intermediate	1 "	104836-0-00						
B-47	Upper Shaft Collar	1 "	101486-0-01						
B-48	Set Screw for B-47	2 pcs.	100013-0-03						

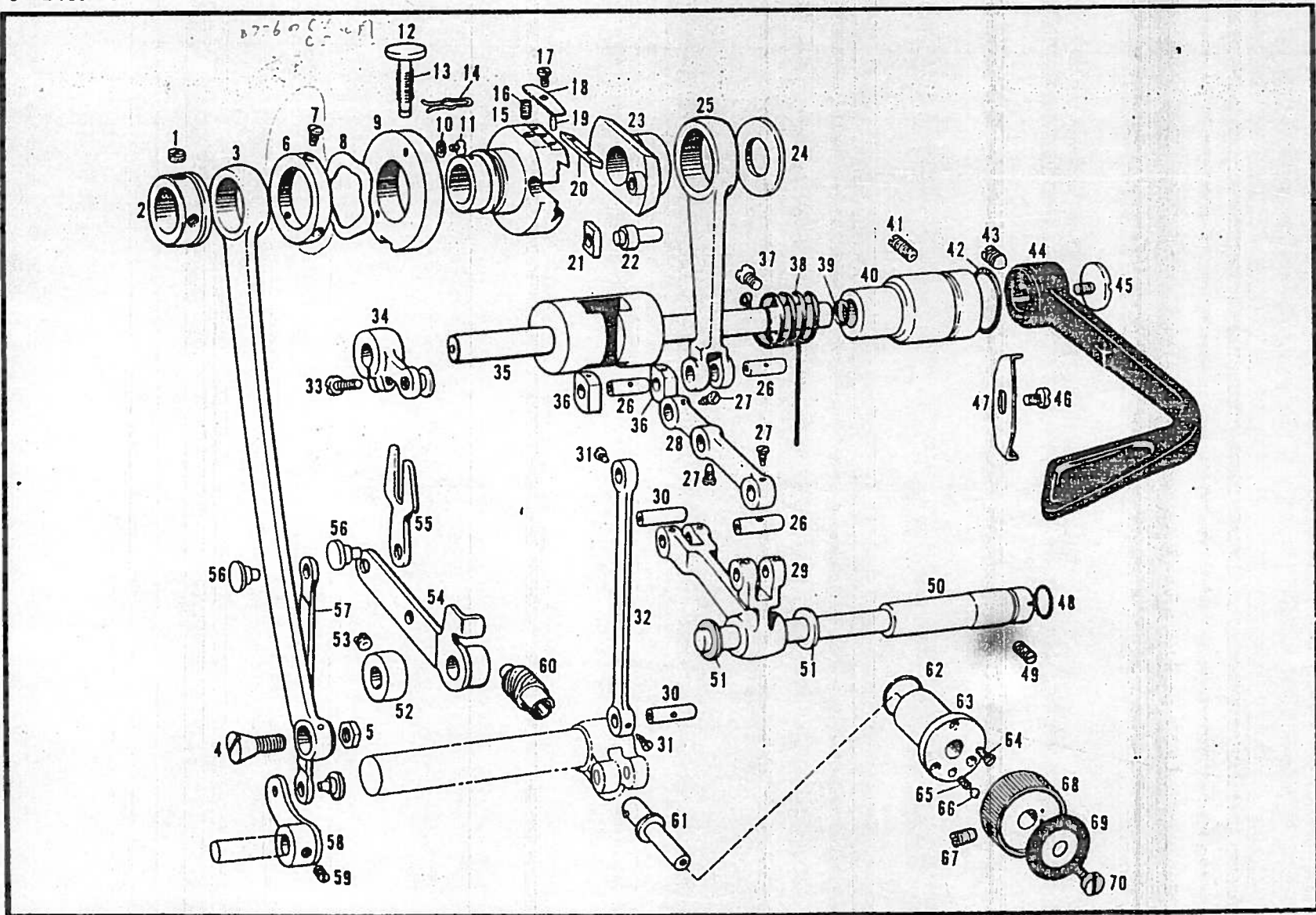

PARTS LIST FOR DB2-B780

B780-C 7

Ref.No.	Name of Parts	Q'ty	Parts No.	Assembly No.	Ref.No.	Name of Parts	Q'ty	Parts No.	Assembly No.
C-1	Set Screw for C-2	2 pcs.	101706-0-01		C-48	Packing AN6227-7 for C-50	1	110558-0-01	
C-2	Vibration Feed Eccentric	1 pce.	113349-0-01		C-49	Set Screw for C-50	1	100016-0-03	
C-3	Vertical Feed Connecting Rod	1	110538-0-01		C-50	Differential Feed Control Lever Shaft	1	110493-0-01	
C-4	Taper Screw for C-3	1	100310-0-01		C-51	Ring for C-29	2 pcs.	110194-0-01	
C-5	Nut for C-4	1	104689-0-01		C-52	Set Collar for C-54	1 pce.	110195-0-01	
C-6	Spring Presser	1	101480-0-01		C-53	Set Screw for C-52	2 pcs.	101706-0-01	
C-7	Set Screw for C-6	3 pcs.	101481-0-01	110478-0-01	C-54	Differential Feed Control Lever	1 pce.	110516-0-01	
C-8	Ripple Type Spring	1 pce.	103602-0-02		C-55	Feed Regulating Connecting Rod	1	110517-0-01	
C-9	Eccentric Control Cam	1	110480-0-01		C-56	Stud for C-54	3 pcs.	110519-0-01	110515-0-01
C-10	Cam Ditch Washer	2 pcs.	103601-0-01		C-57	Differential Feed Control Connecting Rod	1 pce.	110518-0-01	
C-11	Set Screw for C-10	2	101479-0-01		C-58	Differential Feed Control Link	1	110520-0-01	
C-15	Eccentric Wheel Clamp	1	112675-0-01		C-59	Set Screw for C-58	2 pcs.	101706-0-01	
C-17	Set Screw for C-18	1 pce.	104767-0-01	110478-0-01	C-60	Differential Feed Control Screw	1 pce.	110532-0-01	
C-18	Gib Stopper	1	104766-0-01		C-61	Differential Feed Control Dial Stud	1	110524-0-00	
C-19	Pin for C-18	2 pcs.	104765-0-01		C-62	Packing AN6227-8 for C-63	1	108549-0-01	
C-20	Gib	1 pce.	103595-0-01		C-63	Differential Feed Control Bushing	1	110523-0-01	
C-21	Block for C-22	1	101477-0-01		C-64	Set Screw for C-63	3 pcs.	102843-0-01	
C-22	Eccentric Wheel Control Pin	1	101476-0-01		C-65	Spring for C-60	1 pce.	117260-0-01	
C-23	Eccentric Wheel	1	103593-0-01		C-66	Steel Ball for C-63	1	071039-7-50	
C-12	Feed Control Button	1 pce.	111471-0-01		C-67	Set Screw for C-68	2 pcs.	100539-0-01	
C-13	Spring for C-12	1	103607-0-00		C-68	Differential Feed Control Dial	1 pce.	110525-0-01	
C-14	Stopper for C-12	1	111825-0-01		C-69	Differential Feed Control Plate	1	110526-0-01	
C-16	Set Screw for C-15	2 pcs.	100016-0-03		C-70	Set Screw for C-69	1	102836-0-03	
C-24	Stopper for C-25	1	101482-0-01						
C-25	Horizontal Feed Connecting Rod	1	110482-0-01						
C-26	Stud for C-25	3 pcs.	110562-0-01						
C-27	Set Screw for C-26	3	110563-0-01	110481-0-01					
C-28	Horizontal Feed Side Connecting Rod	1 pce.	110483-0-01						
C-29	Horizontal Feed Crank	1	110484-0-01						
C-30	Stud for C-32	2 pcs.	110562-0-01						
C-31	Set Screw for C-30	2	110563-0-01						
C-32	Horizontal Feed Vertical Connecting Rod	1 pce.	110485-0-01						
C-33	Set Screw for C-34	1	100086-0-03						
C-34	Feed Regulating Lever Assembly	1 set.	111864-0-01						
C-35	Feed Regulator	1 pce.	110487-0-01	110486-0-01					
C-36	Block for C-35	2 pcs.	110488-0-01						
C-37	Set Screw for C-38	1 pce.	107362-0-02						
C-38	Feed Regulator Spring	1	110490-0-00						
C-39	Packing AN6227-5 for C-35	1	103564-0-01						
C-40	Feed Regulator Bushing	1	110489-0-00						
C-41	Set Screw for C-40	1	100016-0-03						
C-42	Packing AN6227-13 for C-40	1	105708-0-01						
C-43	Set Screw for C-44	1	108748-0-01						
C-44	Direction Control	1	110491-0-01						
C-45	Set Screw for C-44	1	100511-0-01						
C-46	Set Screw for C-47	1	100541-0-02						
C-47	Direction Control Stopper	1	110492-0-01						

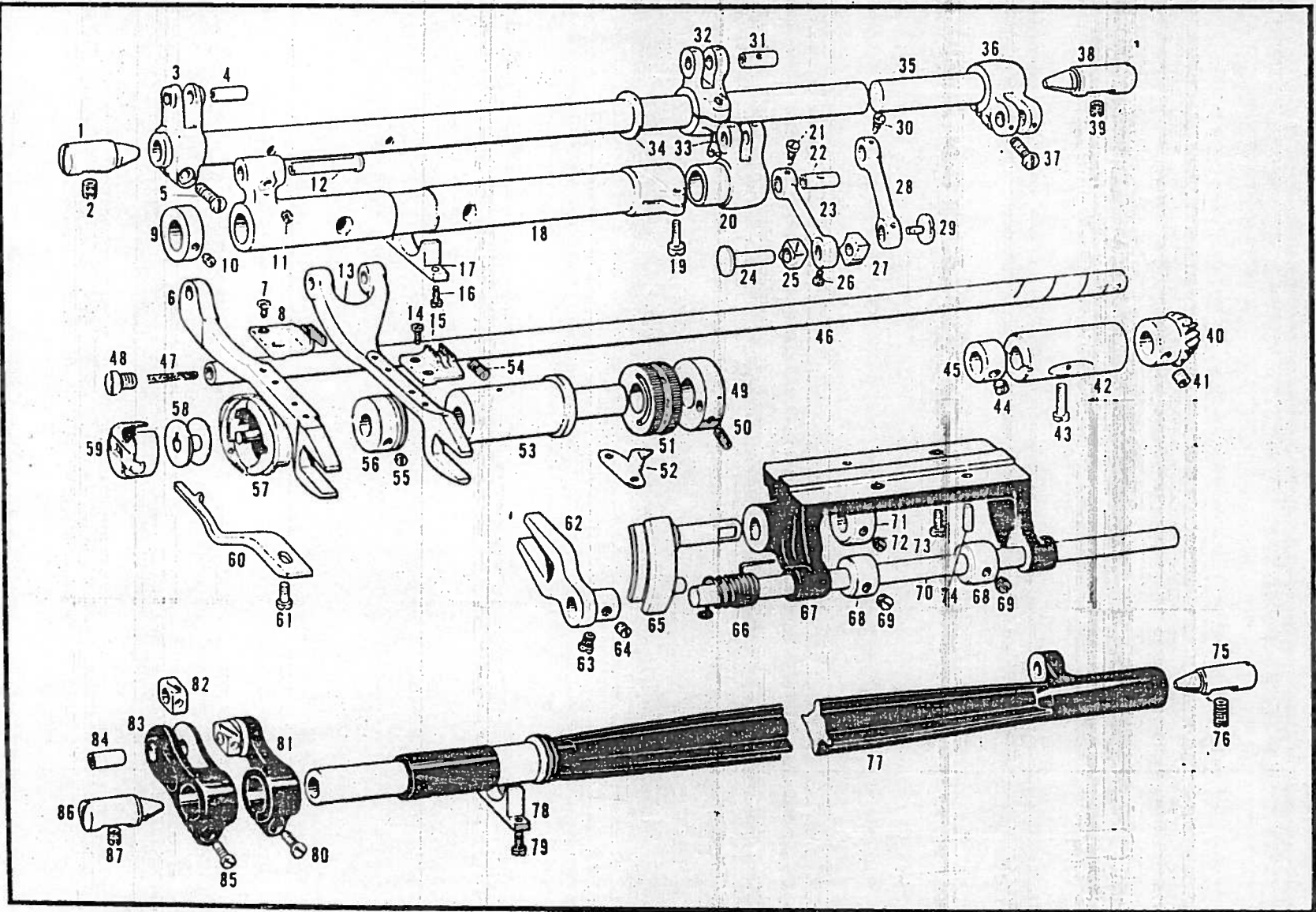

PARTS LIST FOR DB2B780

B780-D 9

Ref.No.	Name of Parts	Q'ty	Parts No.	Assembly No.	Ref.No.	Name of Parts	Q'ty	Parts-No.	Assembly No.
D-1	Taper Center Left for D-35	1 pce.	104847 0 01		D-62	Differential Feed Adjustor Link	1 pce.	110510-0-01	
D-2	Set Screw for D-1	1 "	100013 0 03		D-63	Set Screw for D-62	1 "	102627-0-01	
D-3	Main Feed Bar Arm	1 "	110533 0 01		D-64	Set Screw for D-62	1 "	100251-0-01	110500-0-0
D-4	Stud for D-3	1 "	110535 0 01	110532 0-01	D-65	Differential Feed Adjustor	1 "	110501-0 01	
D-6	Main Feed Bar	1 "	110531 0 01		D-66	Differential Feed Adjustor Spring	1 "	110511-0-01	
D-5	Set Screw for D-3	1 "	106127 0 03		D-71	Set Collar for D-65	1 "	110503-0-01	
D-7	Set Screw for D-8	2 p.s.	101780 0 03		D-72	Set Screw for D-71	2 pcs.	101706 0-01	
D-8	Main Feed	1 pce.	110536 0-01		D-48	Lower Shaft Oil Cap Screw	1 pce.	109173-0 01	
D-9	Set Collar for D-18	1 "	110529 0 01		D-49	Collar for D-52	1 "	109183-0-01	
D-10	Set Screw for D-9	2 pcs.	102716 0-03		D-50	Set Screw for D-49	2 pcs.	109184-0-01	
D-11	Set Screw for D-12	1 pce.	107555-0-01		D-51	Oil Adjusting Ring	1 pce.	109861-0-01	
D-12	Stud for D-13	1 "	110531-0-01		D-52	Latch for D-51	1 "	109862-0-00	
D-13	Sub Feed Bar	1 "	110530 0 01	110527-0-01	D-53	Lower Shaft Bushing Left	1 "	109857-0-01	
D-18	Sub Feed Rock Shaft	1 "	110528 0 01		D-54	Set Screw for D-53	1 "	100539-0-02	
D-19	Set Screw for D-18	1 "	106127-0-02		D-55	Set Screw for D-56	2 pcs.	100218-0-02	
D-14	Set Screw for D-15	2 pcs.	100080-0-03		D-56	Oil Rejector for D-46	1 pce.	104572-1-01	
D-15	Sub Feed	1 pce.	110537-0-01		D-57	Rotary Hook Assembly	1 set.	111277 0-01	116785
D-16	Set Screw for D-17	2 pcs.	100064-0-03		D-58	Bobbin	1 pce.	117132-0-01	
D-17	Oil Stopper for D-18	1 pce.	110550-0-01		D-59	Bobbin Case Assembly	1 set.	100369-0-01	
D-26	Set Screw for D-24	1 "	100130-0-02		D-60	Bobbin Case Holder Position Bracket	1 pce.	110546-0-01	
D-34	Washer for D-20	1 "	110505-0-01		D-61	Set Screw for D-60	1 "	100368-0-02	
D-35	Horizontal Feed Rock Shaft	1 "	110197 0 01		D-67	Holder for D-70	1 "	110502-0-01	
D-36	Horizontal Feed Rock Shaft Arm	1 "	110496-0 01		D-68	Set Collar	2 pcs.	104521-0-01	
D-37	Set Screw for D-36	1 "	100320-0-02		D-69	Set Screw for D-68	4 "	101706-0 01	
D-38	Taper Center Right for D-35	1 "	104848-0-01		D-70	Differential Feed Adjustor Shaft	1 pce.	110512-0-01	
D-39	Set Screw for D-38	1 "	100013-0-03		D-73	Set Screw for D-67	2 "	100154-0-03	
D-40	Lower Shaft Gear	1 "	117875-0-01		D-74	Taper Pin 3x10 for D-67	2 "	100215-0-00	
D-41	Set Screw for D-40	2 pcs.	100251-0-01		D-75	Taper Center Right for D-77	1 pce.	104818-0-01	
D-42	Lower Shaft Bushing Right	1 pce.	104520-0-00		D-76	Set Screw for D-75	1 "	100016 0-03	
D-43	Set Screw for D-42	1 "	100088-0-02		D-77	Feed Lifting Lock Shaft	1 "	110539 0 03	
D-44	Set Screw for D-45	1 "	101706-0-01		D-78	Oil Stopper for D-77	1 pce.	110551-0-01	
D-45	Lower Shaft Collar	1 "	104521-0-01		D-79	Set Screw for D-78	2 pcs.	100064-0-03	
D-46	Lower Shaft	1 "	109160-0-01		D-80	Set Screw for D-81	1 set.	100086-0-03	
D-47	Oil Felt for D-46	1 "	106436-0-01		D-81	Sub Feed Lifting Arm Assembly	1 pce.	110543-0-01	
D-20	Sub Feed Arm	1 "	110504 0 01		D-82	Block for D-83	1 "	110542-0-01	
D-21	Set Screw for D-22	1 "	110563 0 01		D-83	Main Feed Lifting Arm	1 "	110541-0-01	110540-0
D-22	Connecting Stud for D-23	1 "	110562-0-01		D-84	Stud for D-83 & D-82	1 "	110535-0-01	
D-23	Sub Feed Arm Connecting Rod	1 "	110506 0 01		D-85	Set Screw for D-83	1 "	100086-0-03	
D-24	Stud for D-27	1 "	110507-0-01		D-86	Taper Center Left for D-77	1 "	104847-0-01	
D-25	Block for D-62	1 "	11509-9 01		D-87	Set Screw for D-86	1 "	100013-0-03	
D-27	Block for D-65	1 "	110508 0 01	110500 0-01					
D-28	Main Feed Arm Connecting Rod	1 "	110499 0 01						
D-29	Set Screw for D-65	1 "	105451 0 01						
D-30	Set Screw for D-31	1 "	110563-0 01						
D-31	Stud for D-28	1 "	110562 0 01						
D-32	Main Feed Arm	1 "	110498 0 01						
D-33	Set Screw for D-32	1 "	100086 0 03						

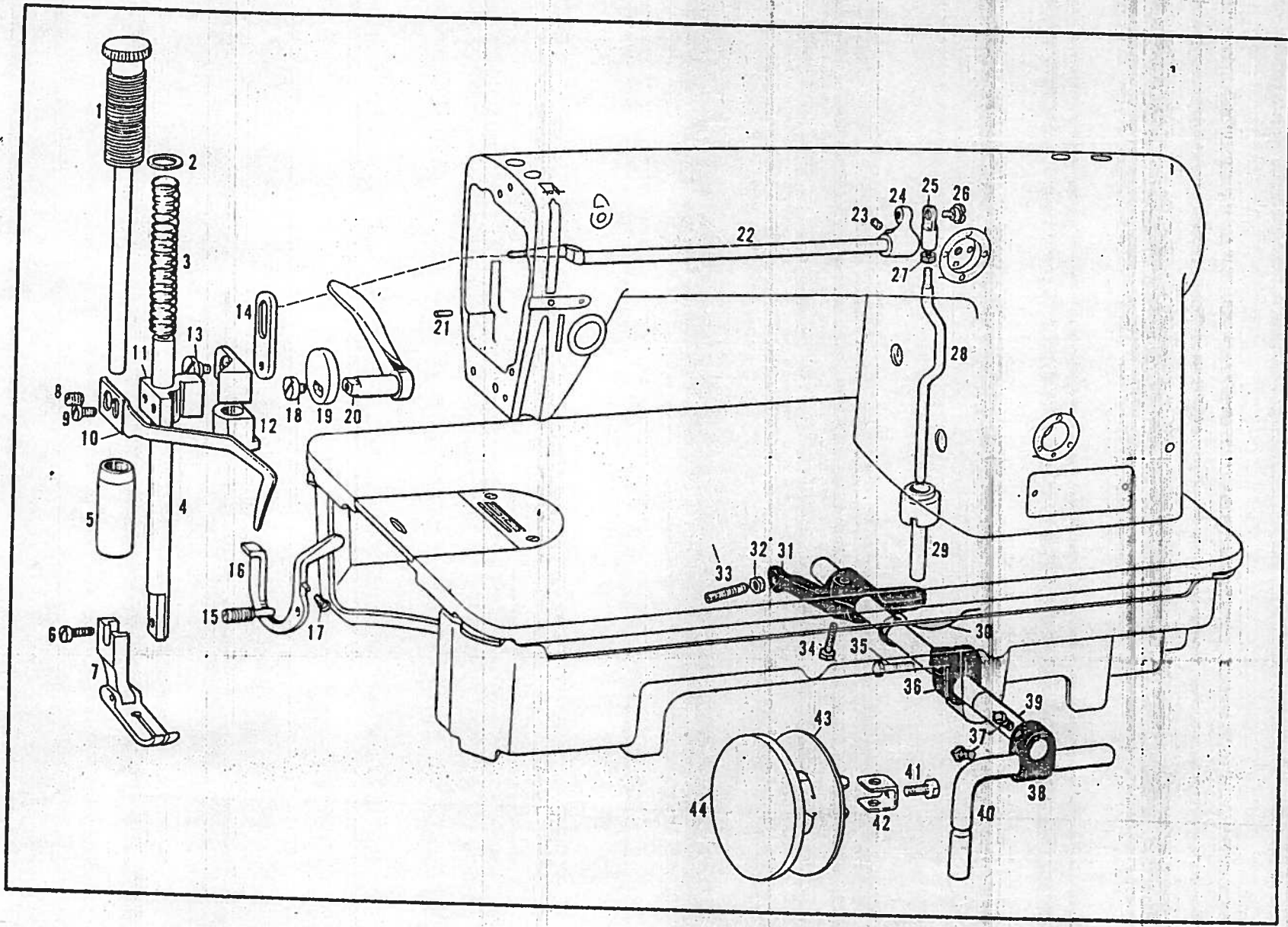

PARTS LIST FOR DB2-B700

B780-E 11

Ref.No.	Name of Parts	Q'ty	Parts-No.	Assembly No.	Ref.No.	Name of Parts	Q'ty	Parts-No.	Assembly No.
E-1	Presser Adjusting Screw	1	110473-0-01						
E-2	Presser Spring Washer	1	100281-0-01						
E-3	Presser Spring	1	110474-0-0C						
E-4	Presser Bar	1	111466-0-01	182056-0-0					
E-5	Presser Bar Bushing	1	111467-0-01						
E-6	Presser Foot Set Screw	1	100287-0-04						
E-7	Presser Foot Complete	1	110475-0-01						
E-8	Set Screw for E-11	1	100013-0-0C						
E-9	Set Screw for E-10	1	100541-0-01	180102-0-0					
E-11	Presser Bar Bracket	1	100497-0-01						
E-10	Presser Bar Bracket Thread Guide D for E-11	1	111469-0-01						
E-12	Presser Bar Lifter Bracket	1	100290-0-01						
E-13	Stud Screw for E-12	1	100294-0-01						
E-14	Presser Bar Lifting Connector	1	109144-0-01						
E-15	Hinge Screw for E-16	1	109163-0-01						
E-16	Tension Release Crank for E-12	1	111470-0-01						
E-17	Tension Release Crank Spring	1	100405-0-01						
E-18	Set Screw for E-19	1	104903-0-01	116319-0-0					
E-19	Presser Bar Lifter Cam	1	116318-0-01						
E-20	Presser Bar Lifter	1	104932-0-01						
E-21	Stopper Pin for E-20	1	101262-0-02						
E-22	Knee Lifter Upper Crank Shaft	1	109145-0-01						
E-23	Set Screw for E-24	1	100251-0-01						
E-24	Knee Lifter Crank A Upper	1	109207-0-0C						
E-25	Knee Lifter Joint	1	104842-0-01						
E-26	Stud Screw for E-25	1	106149-0-02						
E-27	Nut for E-28	1	100301-0-06						
E-28	Knee Lifter Connecting Rod	1	110477-0-01						
E-29	Knee Lifter Coupling Bar	1	104887-0-01						
E-30	Lifter Spring for E-31	1	104886-0-01						
E-31	Knee Lifter Crank B Lower	1	104883-0-02						
E-32	Lock Nut for E-33	1	100022-0-04						
E-33	Screw Stopper for E-32	1	104885-0-01						
E-34	Set Bolt for E-31	1	104884-0-01						
E-35	Set Bolt for E-36	1	104884-0-01						
E-36	Stopper Collar for E-29	1	104890-0-02						
E-39	Knee Lifter Shaft	1	104882-0-01						
E-37	Set Bolt for E-38	1	100463-0-01						
E-38	Knee Lifter Bracket	2	114964-0-01						
E-40	Knee Lifter Bar	1	104619-0-02						
E-41	Set Bolt for E-40 & E-42	1	110087-0-01						
E-42	Knee Lifter Plate Stopper	1	114967-0-01						
E-43	Knee Lifter Plate	1	114966-0-01						
E-44	Knee Lifter Plate Cover	1	114968-0-01						

