

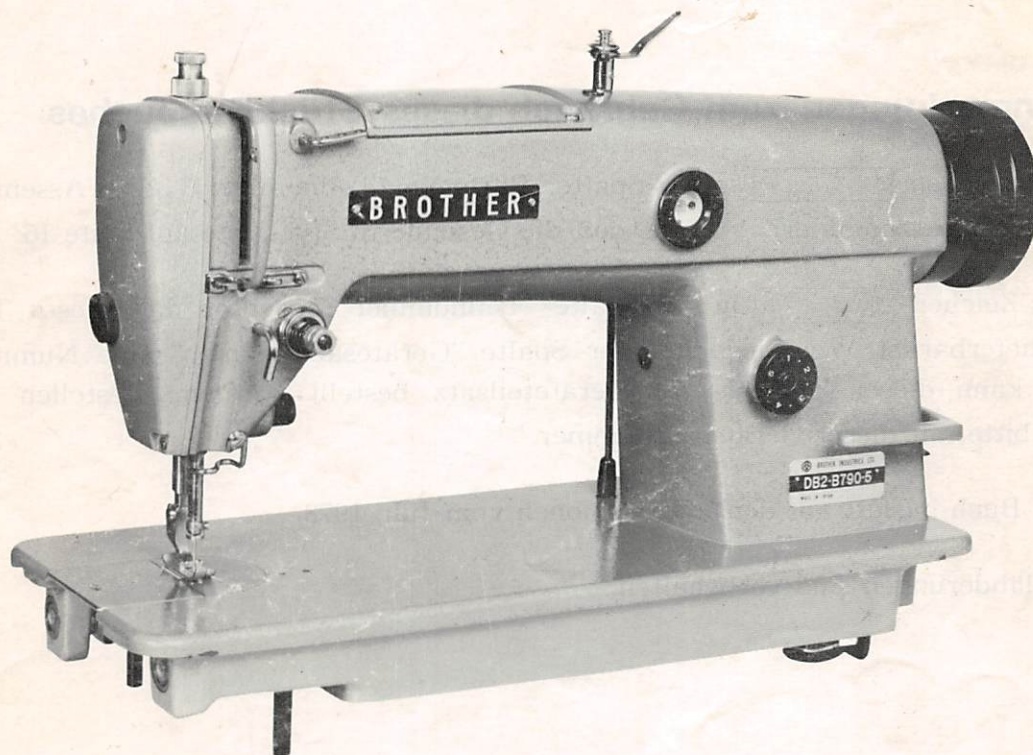

PARTS BOOK
FOR
BROTHER DB2-B790



Needle Feed Lock Stitcher with Thread Trimmer

BROTHER INDUSTRIES, LTD.
NAGOYA, JAPAN

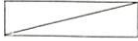

Notes for using this parts book

1. If the symbol  is found in the "Parts No." column or the "Assembly No." column, refer to the different parts list on page 16.
2. The symbol  in the "Parts No." column indicates that the part is not available for supply. If, however, there is a number in the "Assembly No." column, the part can be ordered as an assembly. Please, therefore, order by using the Assembly No..
3. This book was prepared based on information available in July, 1978.
4. Parts are subject to changes in design without prior notice.

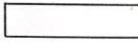
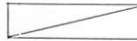

Anmerkungen zum Gebrauch dieses Stücklistebuches

1. Dieses Zeichen  in der Spalte "Parts No. (Teilnummer)" oder "Assembly No. (Gerätesatznummer)" verweist auf die Gesonderte Stückliste auf Seite 16.
2. Dieses Zeichen  in der Spalte "Teilnummer" bedeutet, daß dieser Teil nicht lieferbar ist. Wenn jedoch in der Spalte "Gerätesatznummer" eine Nummer steht, kann dieser Teil als ein Geräteteilsatz bestellt werden. Bestellen Sie daher bitte mit dieser Gerätesatznummer.
3. Dieses Buch basiert auf den Informationen vom Juli, 1978.
4. Modelländerungen sind vorbehalten.

Notes sur l'utilisation de ce manuel de pièces détachées

1. Si le symbole  se trouve dans la colonne "Parts No. (N° de pièce)" ou dans la colonne "Assembly No. (N° jeu de pces)", veuillez vous référer à la liste de pièces annexe page 16.
2. Le symbole  dans la colonne "N° de pièce" signifie que la pièce ne peut être fournie. Si, dans la colonne "N° jeu de pces", il y a un numéro de nomenclature, la pièce peut être commandée comme faisant partie d'un jeu de pièces. Donc, pour toute commande, veuillez spécifier le n° du jeu de pièces.
3. Ce manuel a été fait d'après les renseignements valables au mois de Juillet, 1978.
4. Les pièces peuvent être sujettes à des modifications sans préavis.

Notas para usar este Libro de Piezas

1. De haber un símbolo  junto al "Parts No. (Número de Pieza)" o en la columna del "Assembly No. (Número de Juego)", habrá que mirar la lista de piezas separada de la página 16
2. El símbolo , que se encuentra en la columna del "Número de Pieza", quiere decir que no se dispone de dicha pieza sola. Cuando, empero, hay un número en la columna del "Numero de Juego", se podrá ordenar la pieza con todo el juego. Por lo tanto, será mejor hacer el pedido recurriendo al número del juego respectivo.
3. Este libro ha sido compilado basándose en los datos de que se disponía en Julio de 1978.
4. Las piezas quedan sujetas a cambios de diseño sin aviso previo.

CONTENTS

A. Machine Body and Threading.....	1
B. Upper Shaft, Thread Take-up and Rotary Hook Mechanism.....	2
C. Needle Feed Mechanism.....	3
D. Presser Foot and Knee Lifter Mechanism.....	4
E. Feed Mechanism (Part 1).....	5
E. Feed Mechanism (Part 2).....	6
F. Lubrication (Part 1).....	7
F. Lubrication (Part 2).....	8
G. Thread Trimmer and Tension Releaser (-100, -200, -300, -400, -500, -600).....	9
H. Synchronizer (-100, -200, -300, -400, -500, -600).....	10
J. Thread Wiper Mechanism (-200, -400, -500).....	11
K. Quick Back Mechanism (-300, -400, -500, -600).....	12
L. Presser Lifter and Treadle (-500, -600).....	13
M. Control Box (-500, -600).....	14
Z. Accessories.....	15
DIFFERENT PARTS LIST.....	16
a. Exclusive Parts.....	31
INDEX.....	32

A. Machine Body and Threading

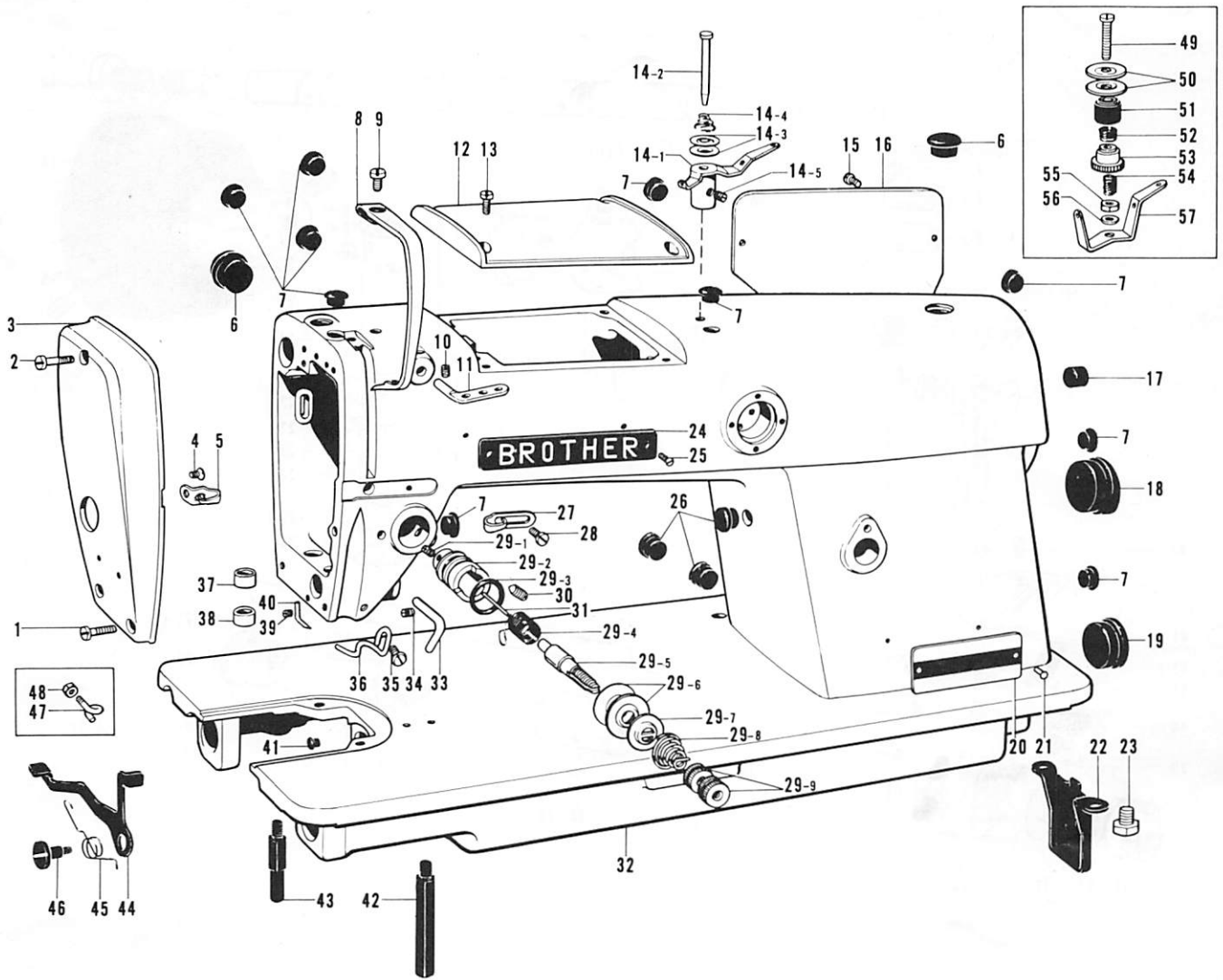

Ref. No.	Name of Parts	Q'ty	Parts No.	Assembly No.	Ref. No.	Name of Parts	Q'ty	Parts No.	Assembly No.
A-1	Screw	2	009671-4-13		A-29-6	Tension Disc	2	145446-0-01	A-29 Upper Tension Regulator Bracket Assembly
A-2	Screw	1	009671-8-13		A-29-7	Tension Disc Washer	1	100134-0-01	
A-3	Face Plate	1	118767-0-01		A-29-8	Tension Spring	1		
A-4	Screw	1			A-29-9	Nut	2	100136-0-01	
A-5	Face Plate Thread Guide	1			A-30	Screw	1	103950-0-02	
A-6	Oil Cap	2	104449-0-01		A-31	Tension Release Pin	1		
A-7	Vinyl Cap	10	104450-0-01		A-32	Arm Bed	1		
A-8	Thread Take-up Cover	1	140885-0-01		A-33	Thread Guide	1	116112-0-01	
A-9	Screw	1	009680-7-13		A-34	Screw	1	011711-4-12	
A-10	Screw	1	013680-6-12		A-35	Screw	1		
A-11	Thread Retainer	1	114931-0-01		A-36	Arm Thread Guide, D	1		
A-12	Top Cover	1	118674-0-01		A-37	Oil Stopper Ring	1	118785-0-00	
A-13	Screw	4	009681-0-14		A-38	Oil Stopper Ring, D	1	147891-0-00	
A-14-1	Pretension	1		A-14 Pretension Assembly	A-39	Screw	1	117666-0-01	
A-14-2	Pretension Stud	1			A-40	Needle Bar Position Pointer	1		
A-14-3	Thread Guide Disc	2	144504-0-01		A-41	Oil Cap	1	142274-0-01	
A-14-4	Spring	1	144505-0-00		A-42	Bed Leg A	1	104829-0-01	
A-14-5	Screw	1	102716-0-03		A-43	Bed Leg B	1	104830-0-01	
A-15	Screw	4	009670-8-12		A-44	Tension Release Crank	1		
A-16	Side Cover	1			A-45	Spring	1		
A-17	Oil Cap	1	104832-0-01		A-46	Screw	1		
A-18	Oil Cap	1	118675-0-01		A-47	Thread Guide	1		
A-19	Oil Cap	1	108520-0-01		A-48	Nut	1		
A-20	Model Plate	1			A-49	Pretension Stud	1		
A-21	Model Plate Pin	2			A-50	Thread Guide Disc	2		
A-22	Pump Cover	1	118672-0-01		A-51	Washer	1		
A-23	Bolt	2	140704-0-01		A-52	Spring	1		
A-24	Name Plate BROTHER	1			A-53	Nut	1		
A-25	Screw	2			A-54	Spring	1		
A-26	Oil Cap	3	104821-0-01		A-55	Nut	1		
A-27	Arm Thread Guide	1	113316-0-01		A-56	Washer	1		
A-28	Screw	1	009670-6-14		A-57	Thread Guide Plate	1		
A-29-1	Screw	1	100402-0-04	A-29 Upper Tension Regulator Bracket Assembly					
A-29-2	Upper Tension Regulator Bracket	1	144741-0-01						
A-29-3	Packing	1	114294-0-01						
A-29-4	Thread Take-up Spring	1							
A-29-5	Tension Stud	1	116922-0-01						

B. Upper Shaft, Thread Take-up and Rotary Hook Mechanism

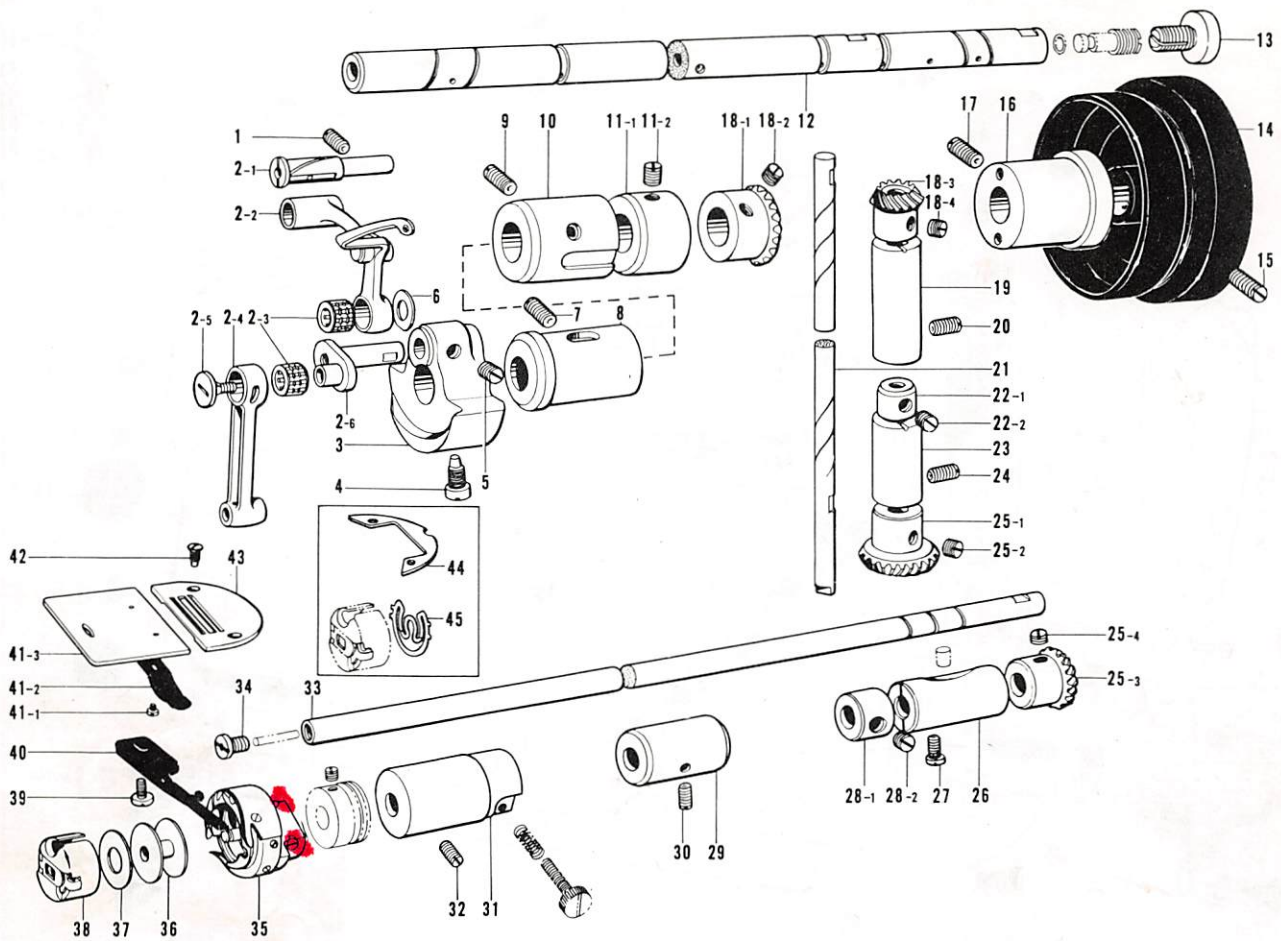

Ref. No.	Name of Parts	Qty	Parts No.	Assembly No.	Ref. No.	Name of Parts	Qty	Parts No.	Assembly No.
B- 1	Screw	1	013761-4-10		B-23	Vertical Shaft Lower Bushing	1	142709-0-00	
B- 2-1	Stud	1	111468-0-01		B-24	Screw	1	013761-4-10	
B- 2-2	Thread Take-up Lever	1		B-2 Needle Bar Connecting Rod Assembly	B-25-1	Vertical Shaft Lower Gear	1		B-25 Lower Gear Assembly 180023-0-01
B- 2-3	Needle Roller Bearing	2	116735-0-00		B-25-2	Screw	3	013770-7-10	
B- 2-4	Needle Bar Crank Rod	1	118829-0-01		B-25-3	Lower Shaft Gear	1		
B- 2-5	Screw	1	145465-0-01		B-25-4	Screw	2	013770-7-10	
B- 2-6	Needle Bar Crank	1			B-26	Lower Shaft Bushing Right	1	104520-1-00	
B- 3	Thread Take-up Crank	1		B-27	Screw	1	121007-0-01		
B- 4	Screw	1	104464-0-01	B-28-1	Lower Shaft Collar	1		B-28 Collar with Screw 181995-0-01	
B- 5	Screw	2	013770-7-10	B-28-2	Screw	2	101706-0-03		
B- 6	Washer	1	110367-0-01	B-29	Lower Shaft Bushing Middle	1	118762-0-00		
B- 7	Screw	1	013761-4-10	B-30	Screw	1	011681-2-12		
B- 8	Upper Shaft Bushing Left	1	118678-0-01	B-31	Lower Shaft Bushing Left	1	118761-1-00		
B- 9	Screw	1	013761-4-10	B-32	Screw	1	013680-8-12		
B-10	Upper Shaft Bushing Middle	1	140726-0-00	B-33	Lower Shaft	1			
B-11-1	Collar	1		B-34	Screw	1	109173-0-01		
B-11-2	Screw	2	013760-8-10	B-35	Rotary Hook Assembly	1			
B-12	Upper Shaft	1	118677-0-01	B-36	Bobbin	1	146290-0-01		
B-13	Screw	1	104478-0-01	B-37	Bobbin Case Sheet	1			
B-14	Pulley	1		B-38	Bobbin Case	1			
B-15	Screw	2	013761-4-10	B-39	Screw	1			
B-16	Upper Shaft Bushing Right	1	146331-0-01	B-40	Bobbin Case Holder Position Bracket	1	140757-0-01		
B-17	Screw	1	013760-6-10	B-41-1	Screw	2	122771-0-01	B-41 Slide Plate Assembly 180018-0-01	
B-18-1	Upper Shaft Gear	1		B-41-2	Slide Plate Spring	1	114561-0-01		
B-18-2	Screw	2	013770-7-10	B-41-3	Slide Plate	1			
B-18-3	Vertical Shaft Gear	1		B-42	Screw	2	100032-0-03		
B-18-4	Screw	2	013770-7-10	B-43	Needle Plate	1			
B-19	Vertical Shaft Upper Bushing	1	142708-0-00	B-44	Needle Plate Washer	1			
B-20	Screw	1	013760-6-10	B-45	Bobbin Presser Spring	1			
B-21	Vertical Shaft	1	144868-0-01						
B-22-1	Lower Shaft Collar	1							
B-22-2	Screw	2	101706-0-03						

C. Needle Feed Mechanism

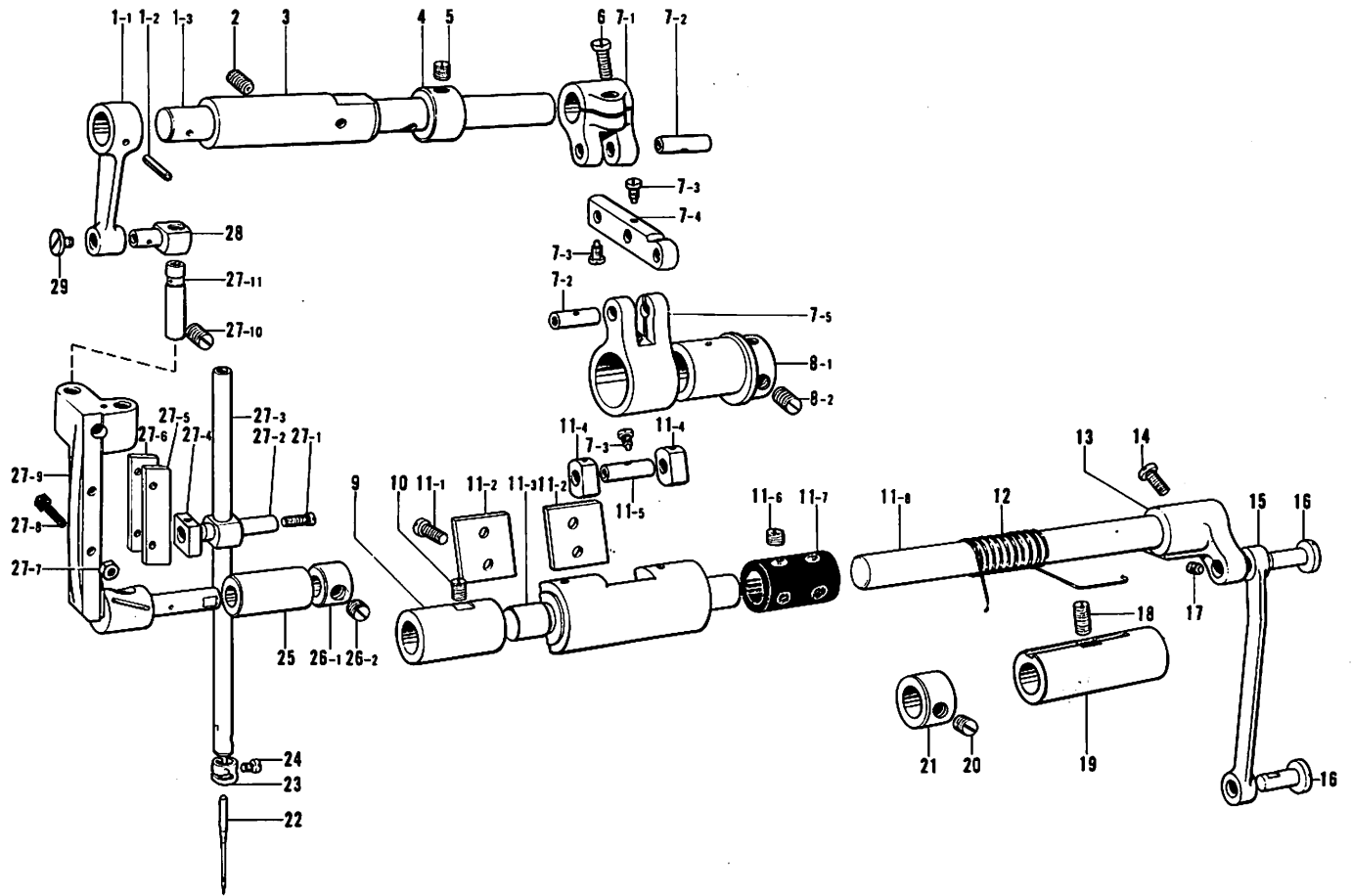

Ref. No.	Name of Parts	Q'ty	Parts No.	Assembly No.	Ref. No.	Name of Parts	Q'ty	Parts No.	Assembly No.
C-1-1	Needle Bar Driving Arm	1		C-1	C-14	Screw	1	009711-2-12	
C-1-2	Pin	1		C-1 Needle Feed Shaft Assembly 118693-0-01	C-15	Needle Feed Regulator Connecting Link	1	118712-0-01	
C-1-3	Needle Feed Shaft	1			C-16	Pin	2	118713-0-01	
C-2	Screw	1	100058-0-03		C-17	Screw	1	013679-4-12	
C-3	Needle Feed Shaft Bushing	1	118696-0-00		C-18	Screw	1	013761-4-10	
C-4	Set Collar	1	146581-0-01		C-19	Bushing Right	1	118708-0-01	
C-5	Screw	2	100260-0-01		C-20	Screw	2	100260-0-01	
C-6	Screw	1	009711-2-12		C-21	Set Collar	1	146581-0-01	
C-7-1	Needle Feed Arm	1		C-7 Needle Feed Connecting Rod Assembly 118698-1-01	C-22	Needle DB×1	1		
C-7-2	Shaft	2	110562-0-01		C-23	Needle Bar Thread Guide	1		
C-7-3	Screw	3	110563-0-01		C-24	Screw	1	140553-0-01	
C-7-4	Needle Feed Motion Transmitter	1	118700-0-01		C-25	Needle Bar Bushing	1	118691-0-01	
C-7-5	Needle Feed Connecting Rod	1	118699-0-01		C-26-1	Collar	1	104521-0-02	C-26 Collar with Screw 145951-0-01
C-8-1	Needle Feed Eccentric Wheel	1		C-8 Needle Feed Eccentric Wheel	C-26-2	Screw	2	014770-6-22	
C-8-2	Screw	2	101706-0-01		C-27-1	Screw	1	118687-0-01	
C-9	Bushing Left	1	118707-0-01		C-27-2	Needle Bar Clamp	1	118686-0-01	
C-10	Screw	1	013760-6-10		C-27-3	Needle Bar	1		
C-11-1	Screw	4	009681-0-12		C-27-4	Needle Bar Guide Slide Block	1	118698-0-01	
C-11-2	Guide Plate	2	118705-0-01		C-27-5	Needle Bar Guide Plate	1	118688-0-01	
C-11-3	Needle Feed Regulator Bracket	1		C-11 Needle Feed Regulator Assembly 118703-0-01	C-27-6	Needle Bar Guide Plate B	1	142425-0-01	
C-11-4	Feed Regulator Slide Block	2	110488-0-01		C-27-7	Nut	2	021670-2-03	
C-11-5	Shaft	1	110562-0-01		C-27-8	Bolt	2	017671-8-12	
C-11-6	Screw	4	101706-0-01		C-27-9	Needle Bar Bracket	1		
C-11-7	Connector	1	118709-0-01		C-27-10	Screw	1	013761-4-10	
C-11-8	Needle Feed Regulator Shaft	1	118706-0-01		C-27-11	Needle Bar Guide Slide Block	1	118690-0-01	
C-12	Spring	1			C-28	Clamp	1	118692-0-01	
C-13	Needle Feed Regulator Shaft Arm	1	148285-0-01		C-29	Screw	1	110711-0-01	

D. Presser Foot and Knee Lifter Mechanism

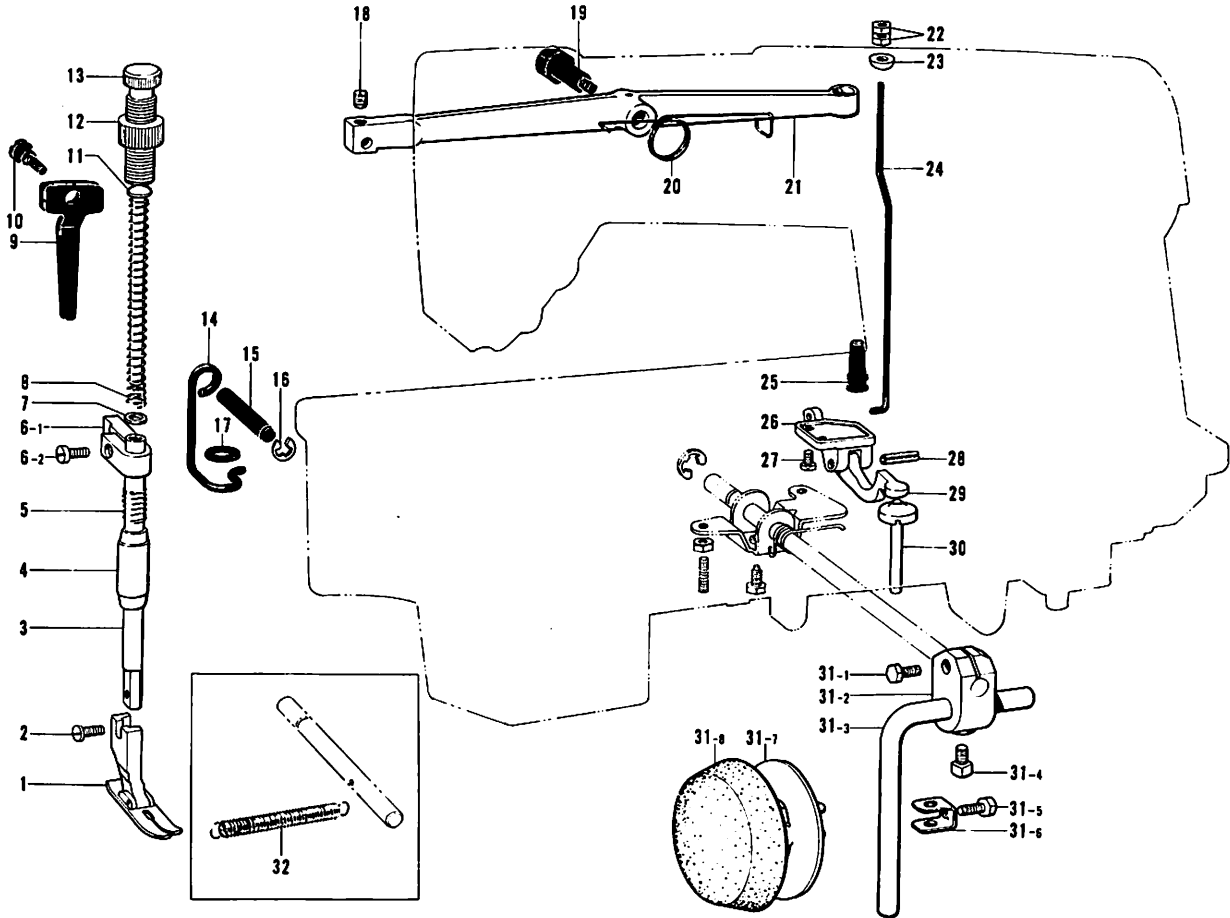

Ref. No.	Name of Parts	Q'ty	Parts No.	Assembly No.	Ref. No.	Name of Parts	Q'ty	Parts No.	Assembly No.
D-1	Presser Foot Assembly	1			D-19	Screw	1	102921-0-02	
D-2	Screw	1	001670-8-14		D-20	Spring	1	116752-0-01	
D-3	Presser Bar	1	111466-0-01		D-21	Knee Lifter	1	148449-0-01	
D-4	Presser Bar Bushing	1	111467-0-01		D-22	Nut	2	110161-0-02	
D-5	Spring	1	118718-0-01		D-23	Washer	1	116748-0-01	
D-6-1	Presser Bar Bracket	1		D-6 Presser Bar Bracket 180952-0-01	D-24	Knee Lifter Connecting Rod	1	148450-0-01	
D-6-2	Screw	1	009671-0-12		D-25	Cover	1	117211-0-01	
D-7	Presser Spring Washer	1	140407-0-01		D-26	Knee Lifter Lever Supporter	1	116751-0-01	
D-8	Spring	1	141728-0-01		D-27	Screw	2	009680-7-12	
D-9	Presser Foot Lifter	1	116743-0-01		D-28	Pin	1	047601-8-42	
D-10	Screw	1	116744-0-01		D-29	Knee Lifter Lever	1	118723-0-01	
D-11	Presser Spring Bar	1	141208-0-01		D-30	Knee Lifter Complying Bar	1	116798-0-01	
D-12	Nut	1	147846-0-01		D-31-1	Bolt	1	017762-0-13	D-31 Knee Lifter Assembly
D-13	Screw	1	141207-0-01		D-31-2	Knee Lifter Joint	1	146039-0-01	
D-14	Presser Bar Lifting Connector	1	118720-0-01		D-31-3	Knee Lifter Bar	1	104619-0-02	
D-15	Presser Bar Lifter Shaft	1	116746-0-01		D-31-4	Bolt	1	100463-0-01	
D-16	Stop Ring	1	048040-3-42		D-31-5	Bolt	1	110087-0-01	
D-17	Washer	1	118719-0-01		D-31-6	Knee Lifter Plate Stopper	1	114967-0-01	
D-18	Screw	1	013760-8-12		D-31-7	Knee Lifter Plate	1	114966-0-01	
					D-31-8	Knee Lifter Cover	1	140503-0-01	
					D-32	Spring	2		

E. Feed Mechanism (Part 1)

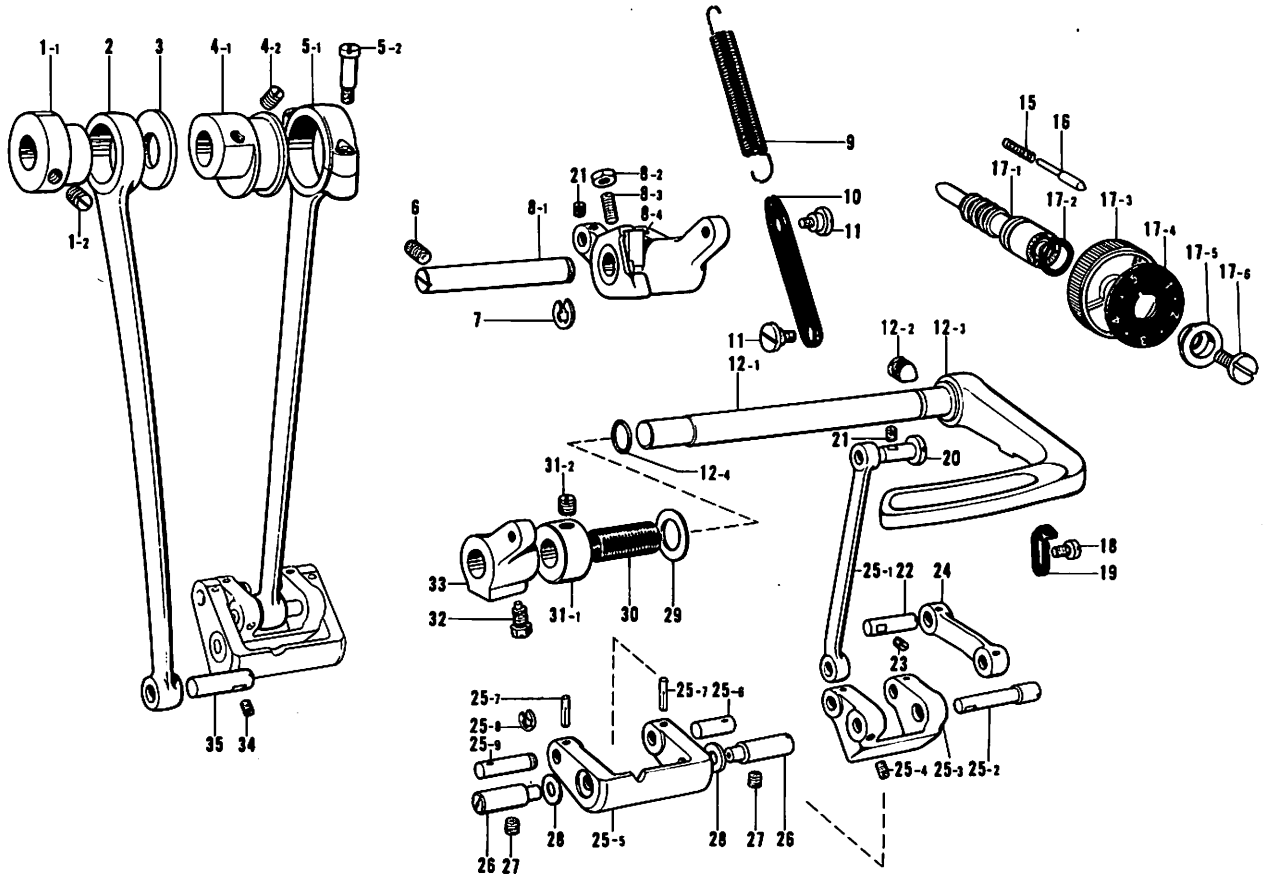

Ref. No.	Name of Parts	Q'ty	Parts No.	Assembly No.	Ref. No.	Name of Parts	Q'ty	Parts No.	Assembly No.
E- 1-1	Vertical Feed Eccentric Wheel	1		E-1	E-18	Screw	1	009680-7-14	
E- 1-2	Screw	2	013760-8-10	Eccentric Wheel	E-19	Reverse Lever Stopper	1	118865-0-01	
E- 2	Vertical Feed Connecting Rod	1	118758-0-01		E-20	Pin	1	118713-0-01	
E- 3	Stopper	1	101482-0-01		E-21	Screw	2	013689-4-12	
E- 4-1	Eccentric Wheel	1		E-4	E-22	Feed Rock Shaft Arm Pin	1	118740-0-01	
E- 4-2	Screw	2	013760-8-10	Eccentric Wheel	E-23	Screw	1	013689-4-12	
E- 5-1	Crank Rod	1		E-5	E-24	Lever Feed Connecting Rod	1	118736-0-01	
E- 5-2	Screw	2	144712-0-01	Crank Rod 118725-0-01	E-25-1	Lever Regulator Connecting Rod	1	118730-0-01	
E- 6	Screw	1	013760-8-10		E-25-2	Stud	1	118737-0-01	
E- 7	Stop Ring	1	048070-3-42		E-25-3	Lever Feed Link	1	118729-0-01	
E- 8-1	Feed Controller Shaft	1	118744-0-01	E-8	E-25-4	Screw	1	013689-4-12	E-25 Feed Regulator Assembly 118727-0-01
E- 8-2	Nut	1	105234-0-01	Feed Controller Assembly 118741-0-01	E-25-5	Feed Regulator	1		
E- 8-3	Screw	1	011681-2-12		E-25-6	Stud Small	1	118732-0-01	
E- 8-4	Feed Controller	1			E-25-7	Pin	2	118733-0-01	
E- 9	Spring	1			E-25-8	Stop Ring	1	048040-3-42	
E-10	Connecting Plate	1	118746-0-01		E-25-9	Stud Large	1	118731-0-01	
E-11	Screw	2	112072-0-01		E-26	Feed Regulator Shaft	2	118734-0-01	
E-12-1	Feed Controller Lever Shaft	1	118751-0-01		E-27	Screw	2	013760-8-10	
E-12-2	Set Screw	1	015771-0-12		E-28	Washer	2	118735-0-01	
E-12-3	Reverse Lever	1		E-12	E-29	Washer	1	025100-1-30	
E-12-4	O Ring	1	104564-0-01	Reverse Lever	E-30	Collar	1	118748-0-01	
E-15	Spring	1	100328-0-01		E-31-1	Collar	1		E-31 Collar with Screw 118824-0-01
E-16	Pin	1	100327-0-01		E-31-2	Screw	2	013760-8-10	
E-17-1	Length Control Screw	1	109151-0-01	E-17	E-32	Bolt	1	108749-0-01	
E-17-2	Packing	1	108549-0-01	Length Control Assembly 181482-0-01	E-33	Feed Regulator Bracket	1	118747-0-01	
E-17-3	Length Control	1	142482-0-01		E-34	Screw	1	013689-4-12	
E-17-4	Feed Regulator Plate	1	146183-0-01		E-35	Feed Rock Shaft Arm Pin	1	109153-0-01	
E-17-5	Washer	1	142746-0-02						
E-17-6	Screw	1	142747-0-02						

E. Feed Mechanism (Part 2)

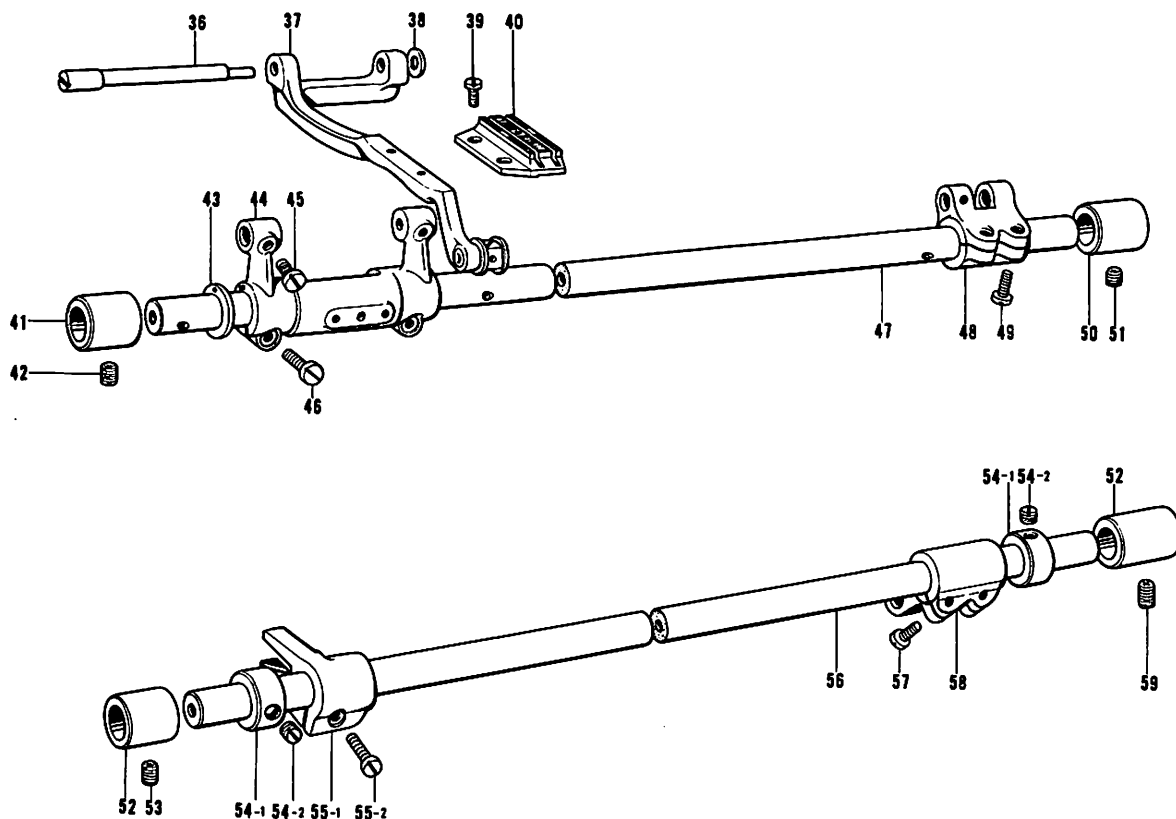

Ref. No.	Name of Parts	Q'ty	Parts No	Assembly No.	Ref. No.	Name of Parts	Q'ty	Parts No.	Assembly No.
E-36	Feed Bar Shaft	1	116917-0-01		E-51	Screw	1	101706-0-01	
E-37	Feed Bar	1	181523-0-01		E-52	Feed Shaft Bushing Small	2	116766-0-01	
E-38	Ring	1	115663-0-01		E-53	Screw	1	101706-0-01	
E-39	Screw	2	100080-0-03		E-54-1	Collar	2		E-54 Collar with Screw 180321-0-01
E-40	Feed Dog	1			E-54-2	Screw	4	101706-0-01	
E-41	Feed Shaft Bushing Small	1	116766-0-01		E-55-1	Feed Lifting Arm	1		E-55 Feed Lifting Arm Assembly 180322-0-01
E-42	Screw	1	101706-0-01		E-55-2	Screw	1	009681-2-12	
E-43	Thrust Ring	1	116920-0-01		E-56	Vertical Feed Shaft	1	142572-0-01	
E-44	Feed Bar Arm	1	145510-0-00		E-57	Screw	2	009681-2-12	
E-45	Screw	2	104908-0-01		E-58	Feed Rock Shaft Arm	1		
E-46	Screw	2	009681-2-12		E-59	Screw	1	013770-7-10	
E-47	Feed Rock Shaft	1	142573-0-01						
E-48	Feed Rock Shaft Arm	1	148286-0-01						
E-49	Screw	2	009711-2-12						
E-50	Feed Shaft Bushing Left	1	116919-0-01						

F. Lubrication (Part 1)

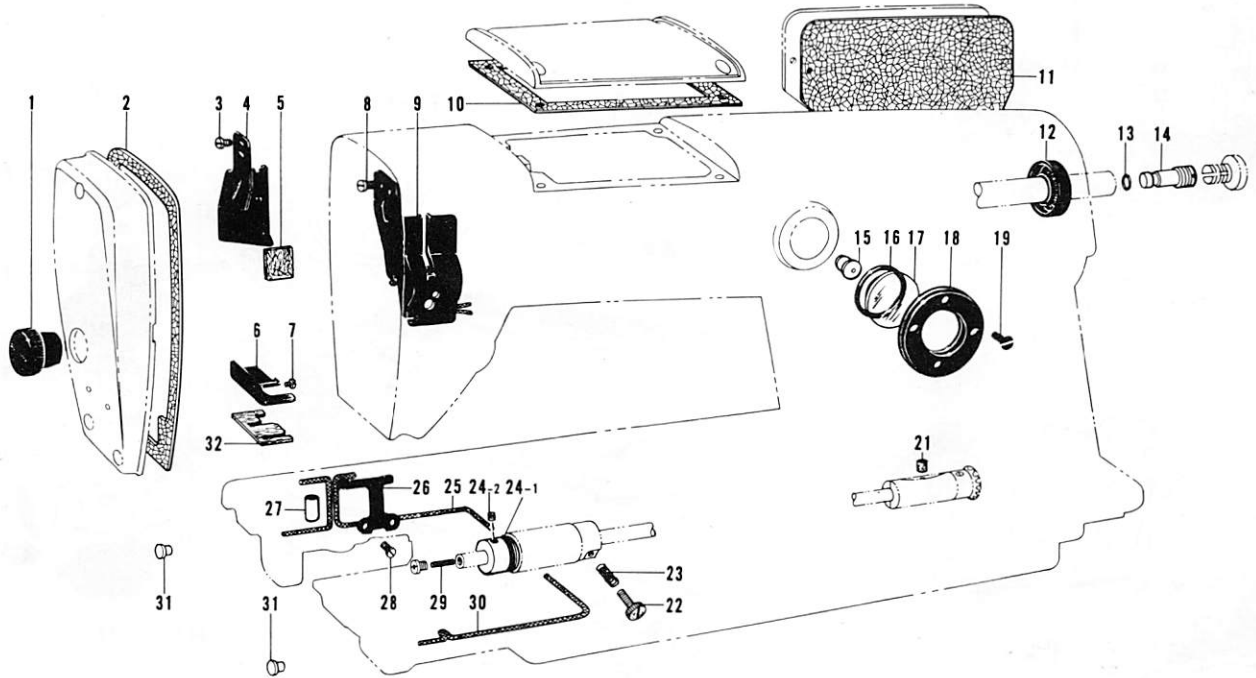

Ref. No.	Name of Parts	Q'ty	Parts No.	Assembly No.	Ref. No.	Name of Parts	Q'ty	Parts No.	Assembly No.
F- 1	Oil Cap	1	112782-0-01		F-18	Oil Gauge Flange	1	104546-0-01	
F- 2	Packing	1	118777-0-01		F-19	Screw	4	102538-0-02	
F- 3	Screw	2	009670-4-12						
F- 4	Oil Stopper Plate	1	118781-0-01		F-21	Felt	1	107155-0-01	
F- 5	Felt	1	118782-0-01		F-22	Screw	1	145534-0-01	
F- 6	Oil Stopper Plate	1	118786-0-01		F-23	Spring	1	116794-0-01	
F- 7	Screw	2	009660-3-02		F-24-1	Oil Rejector	1		F-24
F- 8	Screw	2	009670-5-12		F-24-2	Screw	2	013689-4-12	Oil Rejector
F- 9	Oil Stopper Plate	1	181640-0-01		F-25	Wick	1	108801-0-01	
F-10	Packing	1	118779-0-01		F-26	Wick Supporter	1	109171-0-01	
F-11	Packing	1	118778-0-01		F-27	Vinyl Tube	2	104566-0-01	
F-12	Oil Seal	1	101487-0-00		F-28	Screw	1	009679-3-12	
F-13	O Ring	1	081002-6-70		F-29	Oil Felt	1		
F-14	Oil Screw Rightfor Upper Shaft	1	104555-0-01		F-30	Wick	1	108802-0-01	
F-15	Oil Hole Bolt for Oil Gauge	1	143196-0-01		F-31	Oil Cap	4	111865-0-01	
F-16	O Ring	1	081014-6-70		F-32	Felt	1	150306-0-01	
F-17	Oil Gauge Window	1	104547-0-01						

F. Lubrication (Part 2)

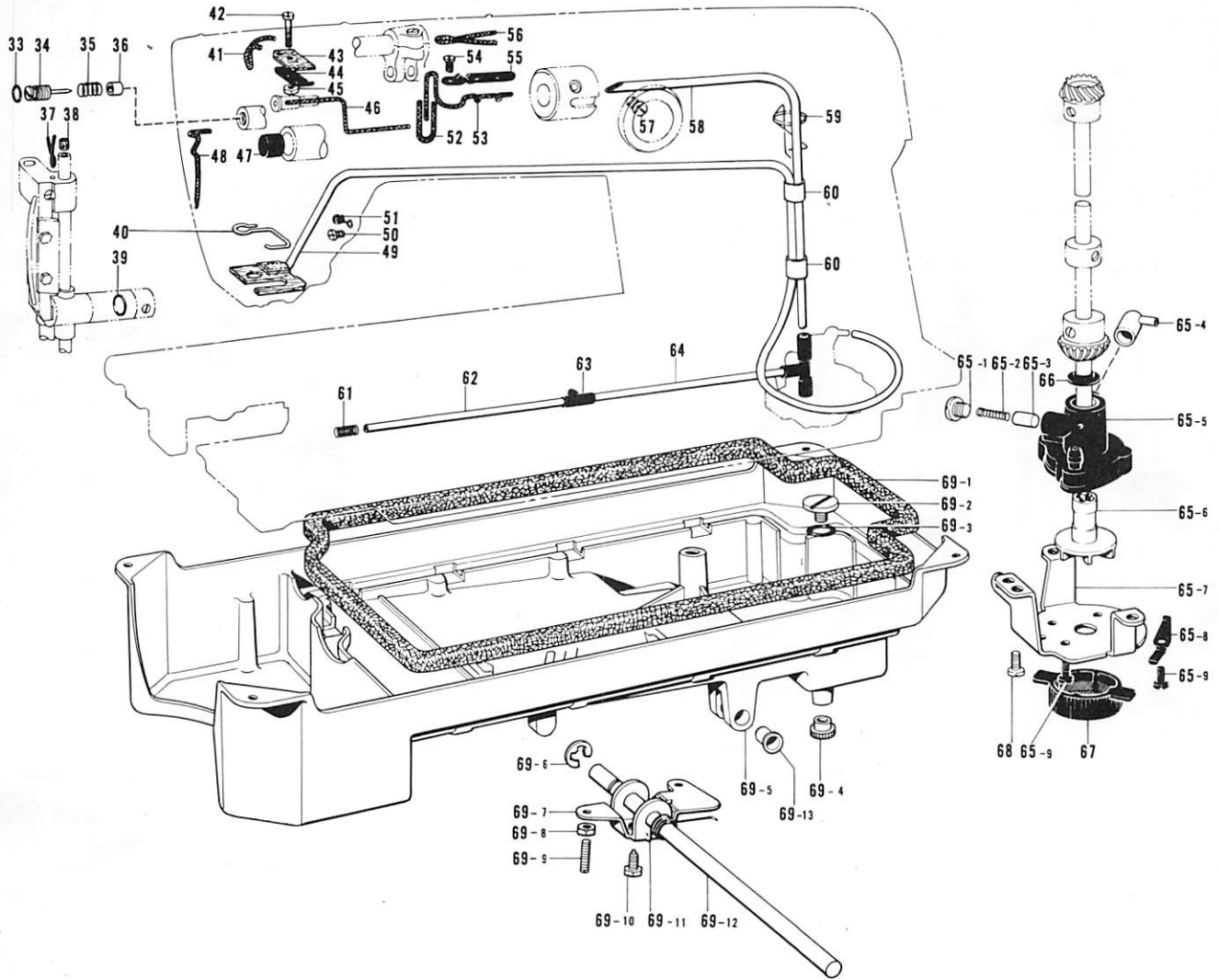

Ref. No.	Name of Parts	Q'ty	Parts No.	Assembly No.	Ref. No.	Name of Parts	Q'ty	Parts No.	Assembly No.
F-33	Packing	1	118770-0-01		F-61	Spring	1	100328-0-01	
F-34	Oil Adjusting Screw for Upper Shaft	1	140412-0-01		F-62	Vinyl Tube	1	146323-0-00	
F-35	Spring	1	116799-0-01		F-63	Tube Joint	1	146324-0-01	
F-36	Oil Bushing	1	140357-0-01		F-64	Oil Tube	1	146319-0-01	
F-37	Wick	1	140438-0-01		F-65- 1	Screw	1	112467-0-02	
F-38	Needle Bar Cork	1	111863-0-01		F-65- 2	Spring	1	144876-0-01	
F-39	O Ring	1	111194-0-01		F-65- 3	Plunger	1	144875-0-01	
F-40	Felt Supporter	1	150305-0-01		F-65- 4	Joint	1	144878-0-01	F-65 Pump Assembly 181476-1-01
F-41	Wick	1	109405-0-01		F-65- 5	Pump Body	1	148848-0-01	
F-42	Screw	1	009671-4-14		F-65- 6	Pump Propeller	1	148849-0-01	
F-43	Felt	1	118784-0-01		F-65- 7	Pump	1	144869-0-01	
F-44	Felt Supporter	1	118783-0-01		F-65- 8	Spring	2	144874-0-01	
F-45	Nut	1	021670-2-03		F-65- 9	Screw	4	009670-8-12	
F-46	Wick	1	118768-0-01		F-66	Oil Stopper	1	146196-0-01	
F-47	Cap	1	140361-0-01		F-67	Pump Filter	1	144872-0-01	
F-48	Wick	1	118768-0-01		F-68	Screw	3	009680-7-13	
F-49	Oil Tube	1	146398-0-01		F-69- 1	Packing	1	146040-0-01	
F-50	Screw	1	009670-5-12		F-69- 2	Screw	1	140518-0-01	
F-51	Tube Stopper	1	112744-0-01		F-69- 3	O Ring	1	081007-0-70	
F-52	Wick	1	140320-0-00		F-69- 4	Oil Cap	1	140480-0-01	
F-53	Wick	1	118768-0-01		F-69- 5	Oil Pan	1		
F-54	Screw	1	009670-5-12		F-69- 6	Stop Ring	1	146293-0-01	F-69 Oil Pan Assembly
F-55	Wick Holder	1	118788-0-01		F-69- 7	Knee Lifter	1	146037-0-01	
F-56	Wick	1	108802-0-01		F-69- 8	Nut	2	100022-0-04	
F-57	Screw	1	013680-8-12		F-69- 9	Screw	2	104885-0-01	
F-58	Upper Oil Tube	1	146329-0-00		F-69-10	Bolt	1	146367-0-01	
F-59	Tube Guard	1	146326-0-01		F-69-11	Spring	1		
F-60	Vinyl Tube	2	118996-0-00		F-69-12	Knee Lifter Shaft	1		
					F-69-13	Bushing	2	149578-0-00	

G. Thread Trimmer and Tension Releaser (-100, -200, -300, -400, -500, -600)

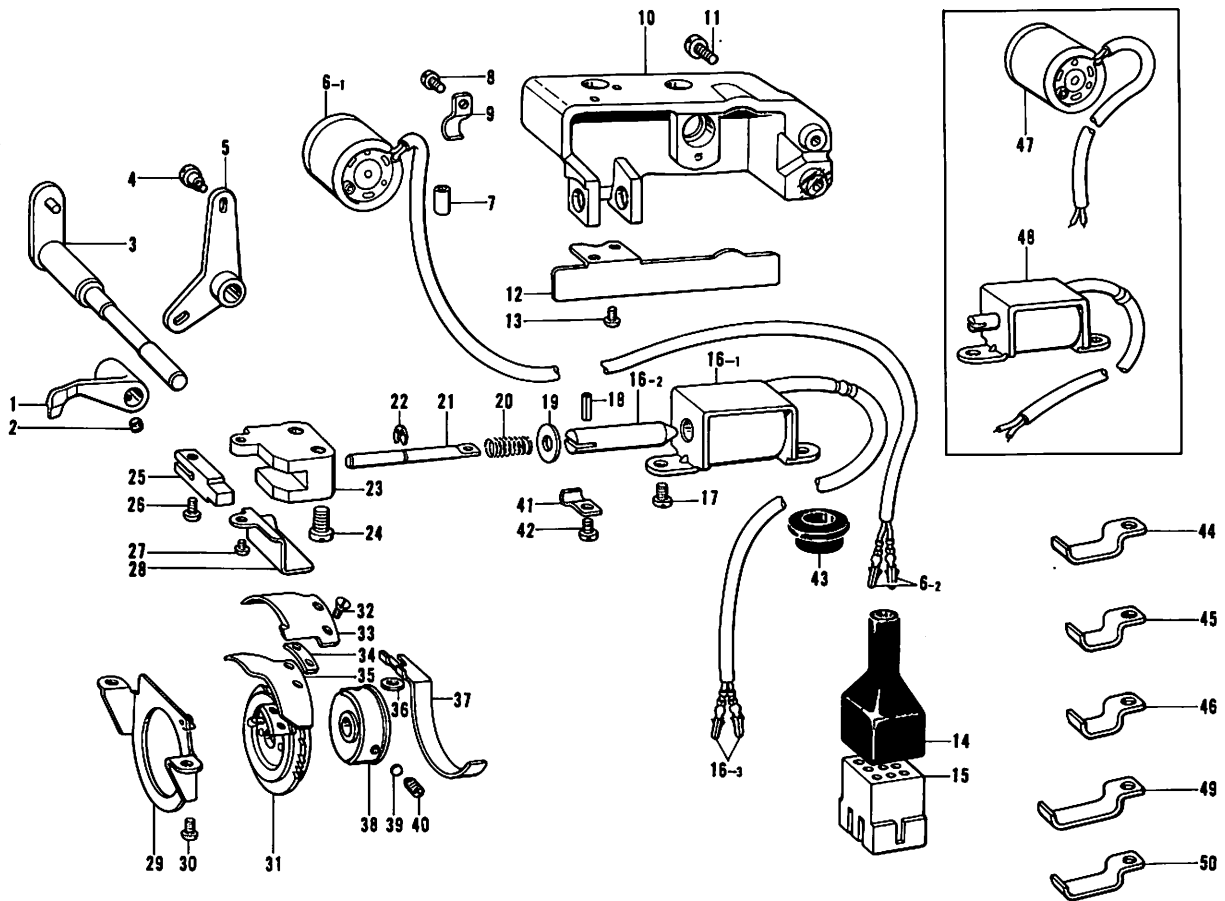

Ref. No.	Name of Parts	Q'ty	Parts No.	Assembly No.	Ref. No.	Name of Parts	Q'ty	Parts No.	Assembly No.
G- 1	Thread Release Lever	1	147103-0-01		G-23	Stopper Guide	1	145618-0-01	
G- 2	Screw	1	102716-0-03		G-24	Screw	2	145619-0-01	
G- 3	Thread Release Link	1	147104-0-01		G-25	Stopper	1	145617-0-01	
G- 4	Screw	1	120263-0-01		G-26	Screw	1	009660-7-12	
G- 5	Thread Release Link	1	147106-0-01		G-27	Screw	1	009679-3-12	
G- 6-1	Rotary Solenoid	1		G-6	Tension Release Solenoid Assembly	G-28	Oil Stopper Plate	1	145623-0-01
G- 6-2	Terminal Pin	2	143549-0-00		G-29	Holder Plate	1	145933-0-01	
G- 7	Vinyl Tube	1	121823-0-01		G-30	Screw	2	009680-6-12	
G- 8	Screw	2	009670-6-12		G-31	Movable Knife Holder Assembly	1	145601-0-01	
G- 9	Supporter	2			G-32	Screw	2	141542-0-01	
G-10	Solenoid Holder	1	147110-1-01		G-33	Movable Knife	1		
G-11	Screw	2	009681-0-13		G-34	Spacer	1		
G-12	Solenoid Cover	1	148451-0-01		G-35	Lower Thread Finger	1		
G-13	Screw	2			G-36	Washer	1	025680-1-33	
G-14	Connector Cap	1			G-37	Movable Knife Cover	1	147946-0-01	
G-15	Nylon Connector	1			G-38	Thread Trimming Clutch	1	145589-1-01	
G-16-1	Thread Trimming Solenoid	1		G-16	Thread Trimming Solenoid Assembly	G-39	Washer	3	147697-0-01
G-16-2	Plunger	1			G-40	Screw	3	014680-6-22	
G-16-3	Terminal Pin	2	143549-0-00		G-41	Cord Holder	2	145595-0-01	
G-17	Screw	2	009680-7-12		G-42	Screw	2	009680-6-12	
G-18	Pin	1	047300-8-42		G-43	Bushing	1	146080-0-00	
G-19	Washer	1	025040-3-35		G-44	Cord Holder	1		
G-20	Spring	1	145621-0-01		G-45	Tube Holder	1		
G-21	Stud	1	145620-0-01		G-46	Tube Holder	2		
G-22	Stop Ring	1	048030-3-42		G-47	Tension Release Solenoid Assembly	1		
					G-48	Thread Trimming Solenoid Assembly	1		
					G-49	Cord Holder	1		
					G-50	Cord Holder	2		

H. Synchronizer (-100, -200, -300, -400, -500, -600)

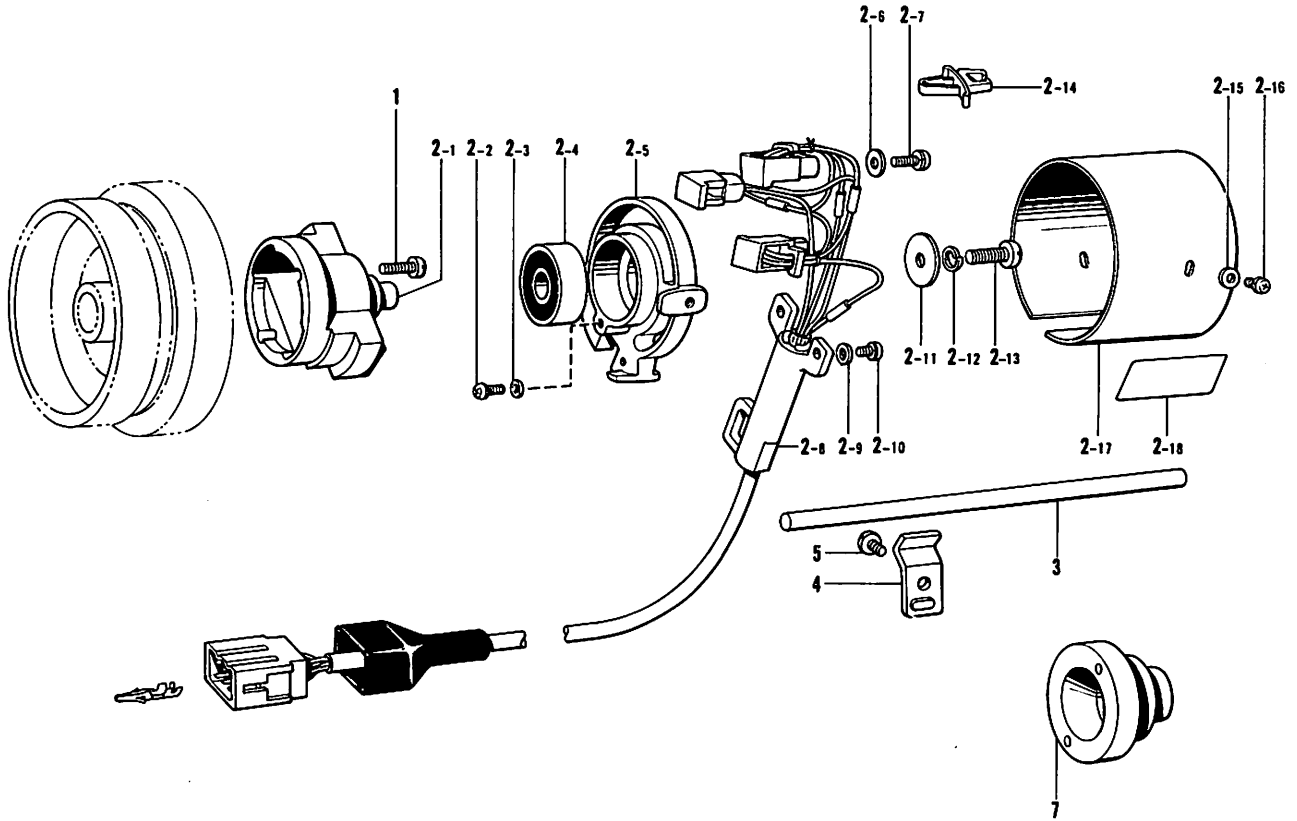

Ref. No.	Name of Parts	Q'ty	Parts No.	Assembly No.	Ref. No.	Name of Parts	Q'ty	Parts No.	Assembly No.
H-1	Screw	2	009711-4-12	H-2 Synchronizer Assembly	H-2-12	Washer	1	028060-2-34	H-2 Synchronizer Assembly
H-2-1	Magnet Stud	1			H-2-13	Screw	1	216880-0-01	
H-2-2	Screw	1	215083-0-01		H-2-14	Cord Holder	1		
H-2-3	Washer	1	025030-3-35		H-2-15	Washer	2	025040-1-35	
H-2-4	Bearing	1			H-2-16	Screw	2	215080-0-01	
H-2-5	Hole IC Holder	1			H-2-17	Synchronizer Cover	1		
H-2-6	Washer	3	025040-3-35		H-2-18	Lavel	1		
H-2-7	Screw	3	217093-0-01		H-3	Synchronizer Holder Bar	1	218944-0-01	
H-2-8	Hole IC with Cord	1	218953-0-01		H-4	Holder	1	216332-0-01	
H-2-9	Washer	2	025040-1-35		H-5	Screw	1	009781-4-12	
H-2-10	Screw	2	215080-0-01		H-7	Slip Ring Support	1		
H-2-11	Washer	1	025060-3-35						

J. Thread Wiper Mechanism (-200, -400, -500)

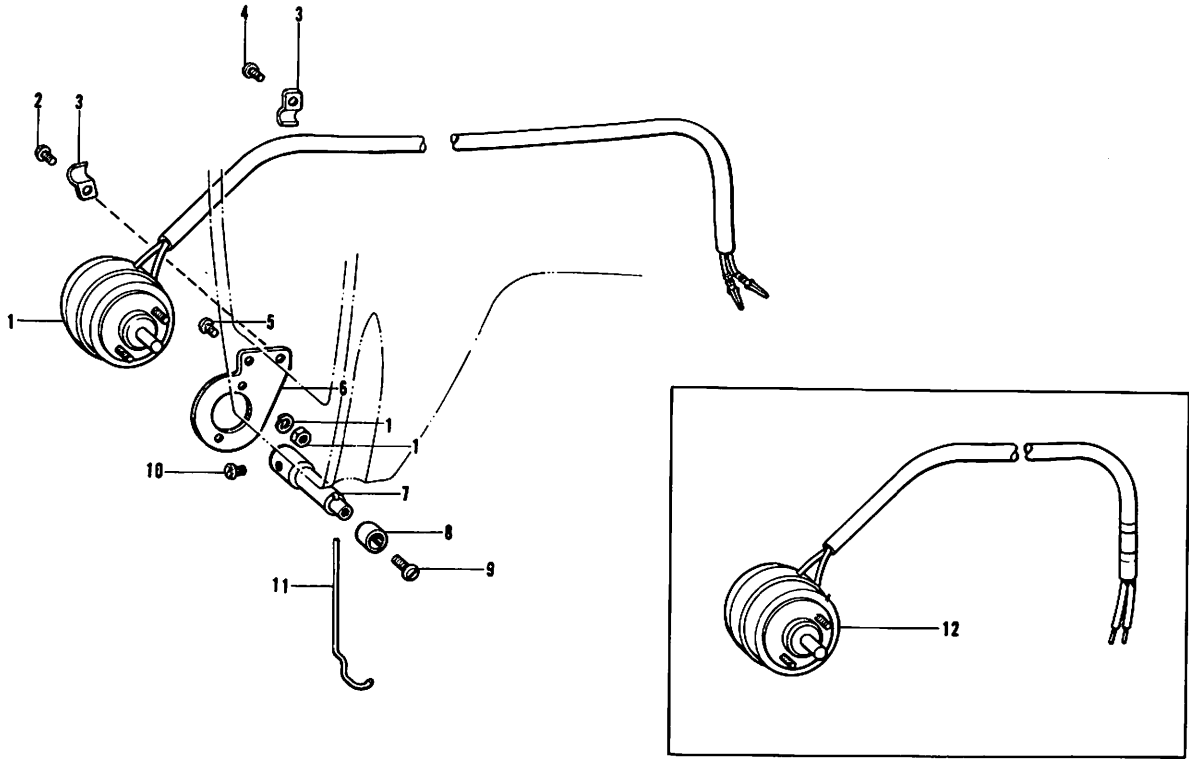

Ref. No.	Name of Parts	Q'ty	Parts No.	Assembly No.	Ref. No.	Name of Parts	Q'ty	Parts No.	Assembly No.
J-1	Thread Wiper Solenoid	1			J-7	Thread Wiper Stud	1	150801-1-01	
J-2	Screw	1	009670-8-12		J-8	Thread Wiper Stud Collar	1	146288-0-01	
J-3	Supporter	2	140647-0-01		J-9	Screw	1	001670-5-14	
J-4	Screw	1	009670-6-12		J-10	Screw	1	144458-0-01	
J-5	Screw	1	009670-6-12		J-11	Thread Wiper	1	150832-0-00	
J-6	Solenoid Holder	1	150800-0-01		J-12	Thread Wiper Solenoid	1		

K. Quick Back Mechanism (-300, -400, -500, -600)

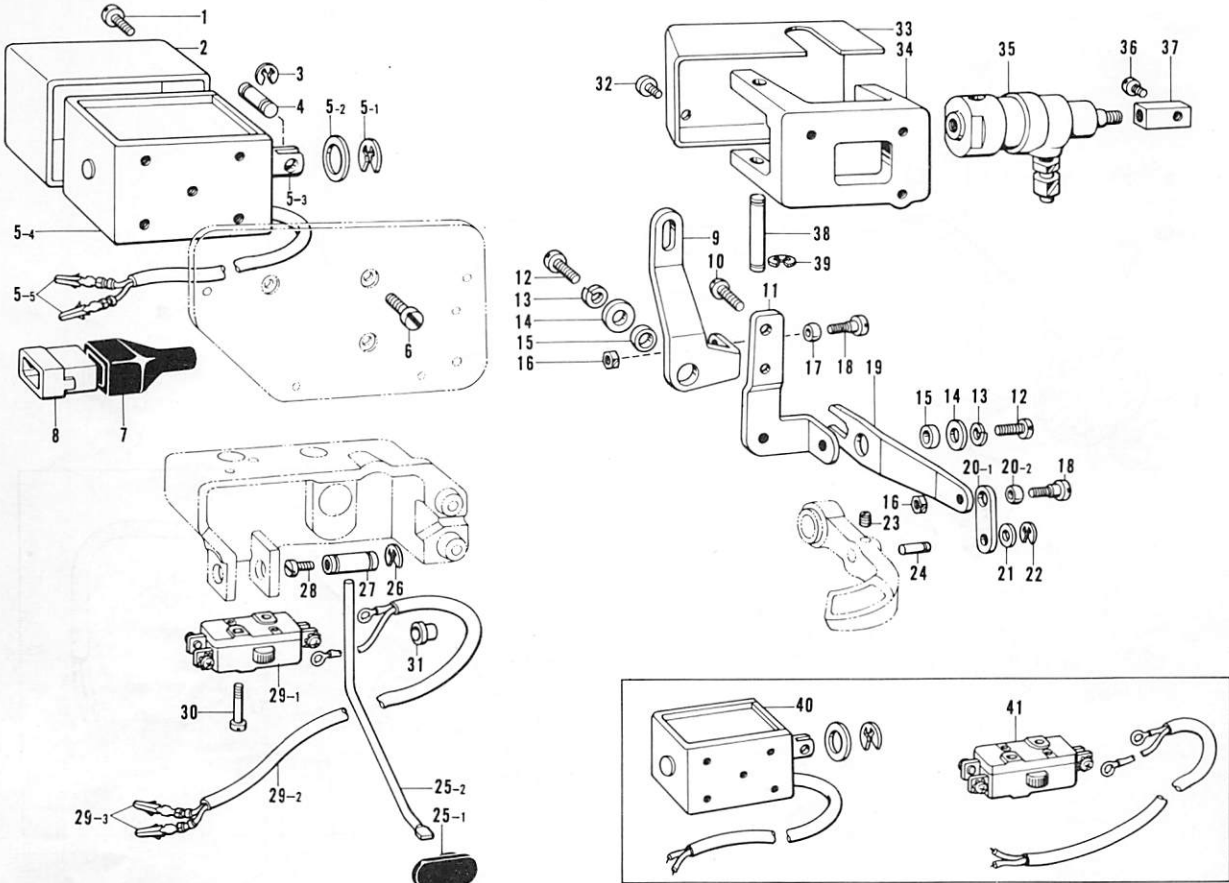

Ref. No.	Name of Parts	Q'ty	Parts No.	Assembly No.	Ref. No.	Name of Parts	Q'ty	Parts No.	Assembly No.
K-1	Screw	1	007501-2-02		K-21	Washer	1	146115-0-00	
K-2	Solenoid Cover	1	148465-0-00		K-22	Stop Ring	1	048040-3-42	
K-3	Stop Ring	2	048040-3-42		K-23	Screw	1	013679-4-12	
K-4	Pin	1	147754-0-01		K-24	Pin	1	146114-0-01	
K-5-1	Stop Ring	1	146103-0-01	K-5 Reverse Solenoid Assembly	K-25-1	Actuator	1	148461-0-01	K-25 Actuator Assembly 148460-0-01
K-5-2	Rubber Stopper	1	146104-0-00		K-25-2	Actuator Bar	1	146128-0-00	
K-5-3	Plunger	1			K-26	Stop Ring	2	048080-3-42	
K-5-4	Solenoid	1			K-27	Actuator Pin	1	146125-0-01	
K-5-5	Terminal Pin	2	143549-0-00		K-28	Screw	1	009681-4-14	
K-6	Screw	3	007500-8-12		K-29-1	Micro Switch	1	140643-0-00	K-29 Switch
K-7	Connector Cap	1		K-29-2	Cord	1	146122-0-00		
K-8	6P Connector	1		K-29-3	Terminal Pin	2	143549-0-00		
K-9	Solenoid Lever Bracket	1	148454-0-01		K-30	Screw	2	146124-0-01	
K-10	Bolt	2	146360-0-02		K-31	Bushing	1	146080-0-00	
K-11	Solenoid Lever	1	148453-0-01		K-32	Screw	2	009670-5-13	
K-12	Screw	2	009761-4-12		K-33	Cover	1	146156-0-01	
K-13	Washer	2	028060-2-42		K-34	Cylinder Holder	1	148853-0-01	
K-14	Washer	2	141343-0-02		K-35	Reverse Cylinder	1	146149-0-01	
K-15	Collar	2	148456-0-01		K-36	Screw	1	141598-0-01	
K-16	Nut	2	021760-3-02		K-37	Piston Rod Connector	1	148854-0-01	
K-17	Bushing	1	141331-0-01		K-38	Reverse Cylinder	1	146148-0-01	
K-18	Screw	2	141494-0-01		K-39	Stop Ring	2	048040-3-42	
K-19	Reverse Link	1	148455-0-01		K-40	Reverse Solenoid Assembly	1		
K-20-1	Connecting Link	1	148457-0-01	K-20 Connecting Link 148467-0-01	K-41	Switch	1		
K-20-2	Bushing	1	141331-0-01						

* Parts K-1 ~ K-4 are for -300, -400 type specifications, and parts K-32 ~ K-39 are for -500, -600 type specifications.

L. Presser Lifter and Treadle (-500, -600)

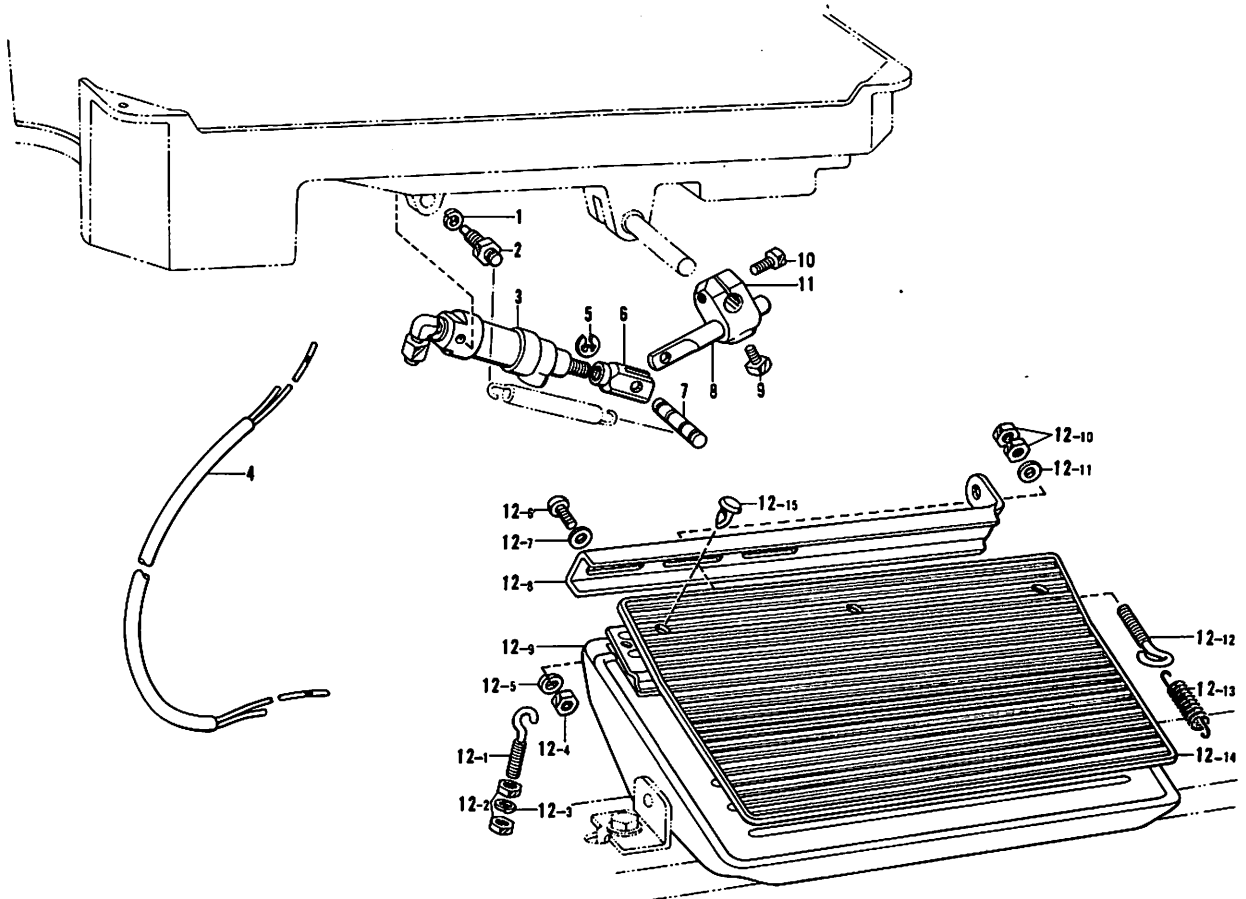

Ref. No.	Name of Parts	Q'ty	Parts No.	Assembly No.	Ref. No.	Name of Parts	Q'ty	Parts No.	Assembly No.
L- 1	Washer	2	028060-2-40		L-12- 4	Nut	2	021060-2-06	L-12 Treadle Assembly 146175-0-01
L- 2	Screw	2	147141-0-01		L-12- 5	Washer	2	028060-2-40	
L- 3	Presser Foot Cylinder	1	146157-0-01		L-12- 6	Screw	2	001061-6-06	
L- 4	Air Tube	1	149548-0-01		L-12- 7	Washer	2	025060-2-36	
L- 5	Stop Ring	2	048040-3-42		L-12- 8	Treadle Connector	1		
L- 6	Piston Rod Joint	1	140627-0-01		L-12- 9	Treadle	1		
L- 7	Pin	1	146986-0-01		L-12-10	Nut	2	021500-1-04	
L- 8	Piston Drive Link	1	140668-0-01		L-12-11	Washer	1	025050-2-33	
L- 9	Bolt	1	100463-0-01		L-12-12	Spring Hook	1	140953-0-01	
L-10	Bolt	1	017762-0-13		L-12-13	Spring	1	146178-0-01	
L-11	Knee Lifter Joint	1	146039-0-01		L-12-14	Rubber	1	109268-0-01	
L-12- 1	Adjusting Hook	1	140947-0-01	L-12 Treadle Assembly 146175-0-01	L-12-15	Clip	3	146358-0-01	
L-12- 2	Nut	2	212251-0-01						
L-12- 3	Washer	1	028040-2-43						

*Parts L-12 are only installed at the BROTHER -600 type specification.

M. Control Box (-500, -600)

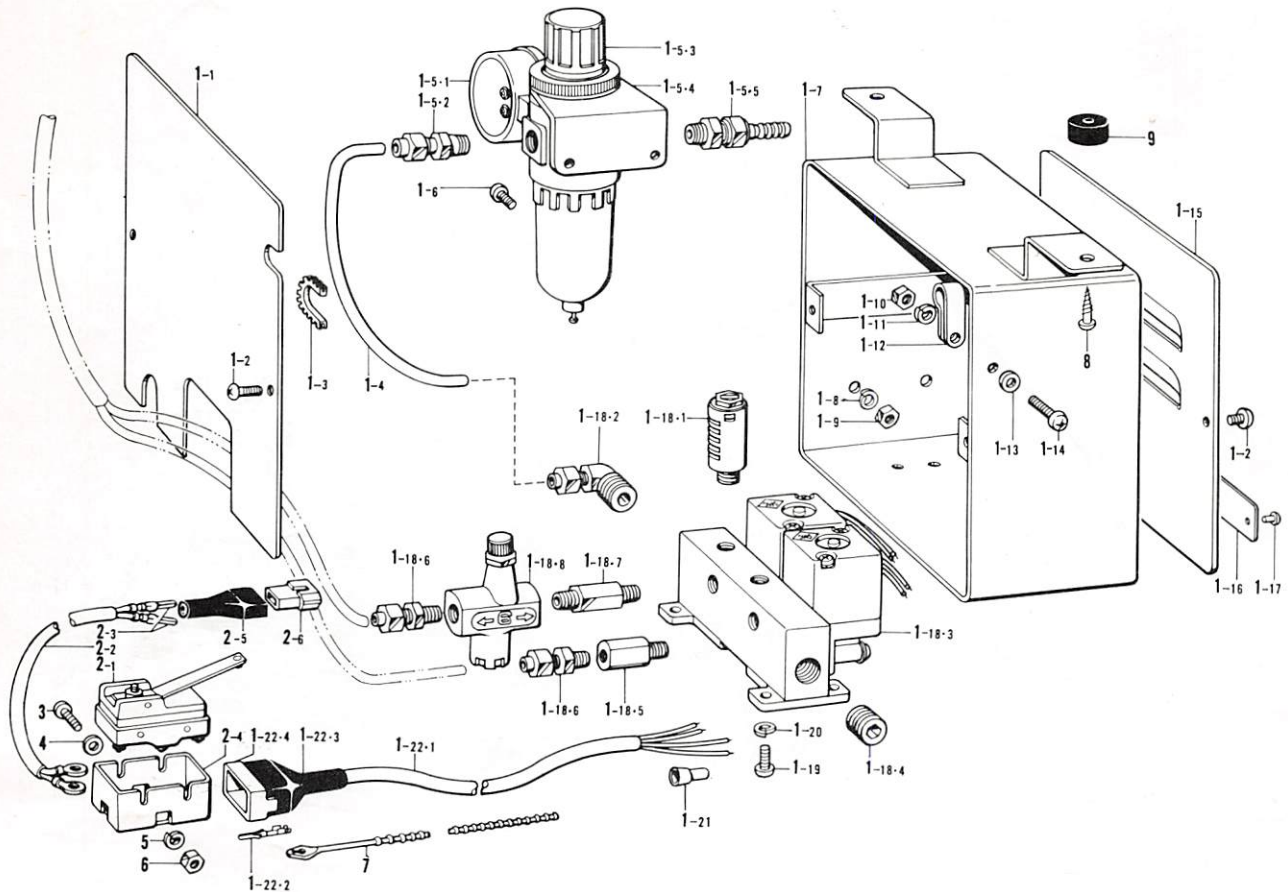

Ref. No.	Name of Parts	Q'ty	Parts No.	Assembly No.	Ref. No.	Name of Parts	Q'ty	Parts No.	Assembly No.
M-1- 1	Back Cover	1			M-1-18-6	1/8" Connector	2	140543-0-00	M-1-18 Solenoid Valve Assembly 149543-0-01
M-1- 2	Screw	4	008400-5-64		M-1-18-7	Speed Control Connector	1	142037-0-00	
M-1- 3	Nylon Bushing	1	146171-0-00		M-1-18-8	Speed Controller	1	142038-0-01	
M-1- 4	Air Tube	1	140540-0-00		M-1-19	Screw	4	002501-0-64	
M-1- 5-1	Presser Gauge	1		M-1-5 Air Unit Assembly 143959-1-03	M-1-20	Washer	4	028050-2-43	M-1-22 Valve Cord Assembly 149545-0-01
M-1- 5-2	1/4" Connector Assembly	1	142349-0-00		M-1-21	Connector	4	206755-0-00	
M-1- 5-3	Valve	1	143960-1-01		M-1-22-1	Valve Cord	1		
M-1- 5-4	Air Unit Holder Plate	1	143962-0-01		M-1-22-2	Terminal Pin	4	143549-0-00	
M-1- 5-5	Air Tube Connector	1	140678-0-00		M-1-22-3	Connector Cap	1	145596-0-01	
M-1- 6	Screw	2	002501-0-64	M-1-22-4	Nylon Connector	1	146118-0-00	M-2 Presser Foot Lifter Cord Assembly 146160-0-01	
M-1- 7	Valve Case	1		M-2- 1	Micro Switch	1	140948-0-01		
M-1- 8	Washer	2	028050-2-43	M-2- 2	Presser Foot Lifter Cord	1			
M-1- 9	Nut	2	021500-1-63	M-2- 3	Terminal Pin	2	143549-0-00		
M-1-10	Nut	1	021300-1-03	M-2- 4	Cover	1	140950-0-00	M-1 Valve Case Assembly 149539-1-01	
M-1-11	Washer	1	028030-2-43	M-2- 5	Connector Cap	1	143489-0-01		
M-1-12	Cord Holder	1	149547-0-00	M-2- 6	Nylon Connector	1	143488-0-01		
M-1-13	Washer	1	025030-1-33	M-3	Screw	2	002303-0-06		
M-1-14	Screw	1	002301-0-03	M-4	Washer	2	025030-2-33	M-1-18 Solenoid Valve Assembly 149543-0-01	
M-1-15	Rear Cover	1		M-5	Washer	2	028030-2-43		
M-1-16	Name Plate	1		M-6	Nut	2	021300-1-03		
M-1-17	Rivet	2		M-7	Bead Band*	1	144189-0-01		
M-1-18-1	Silencer	2	140682-0-01	M-8	Screw	2	100666-0-02	M-2 Presser Foot Lifter Cord Assembly 146160-0-01	
M-1-18-2	1/4" Elbow	1	140538-0-00	M-9	Cushion Rubber	2	115018-0-01		
M-1-18-3	Solenoid Valve	2	149544-0-01						
M-1-18-4	1/4" Cap	1	140542-0-01						
M-1-18-5	Valve Connector	1	140539-0-00						

* Parts M-2~M-7 are for -600 type specification.

Z. Accessories

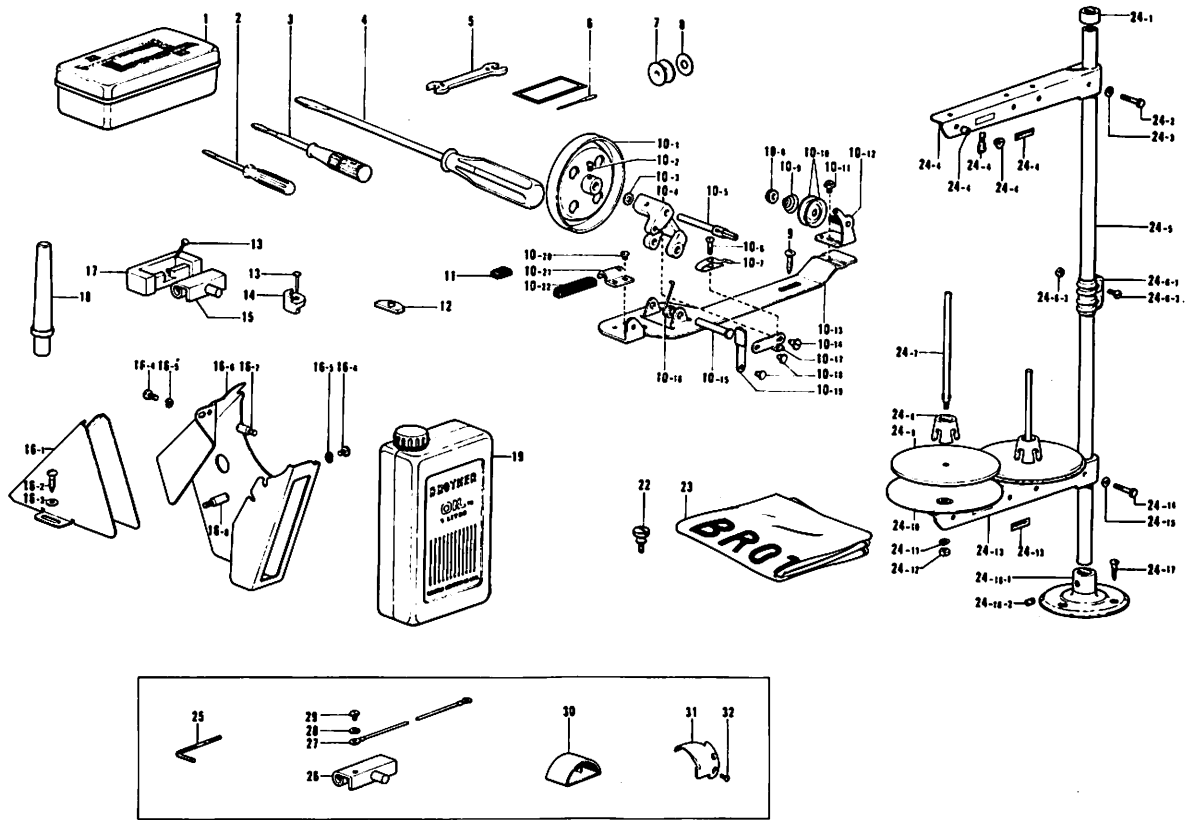

Ref. No.	Name of Parts	Q'ty	Parts No.	Assembly No.	Ref. No.	Name of Parts	Q'ty	Parts No.	Assembly No.
Z- 1	Accessories Box		110436-0-01		Z-16- 5	Washer		028680-2-42	Z-16
Z- 2	Screw Driver		142443-0-01		Z-16- 6	Belt Cover UA		147849-0-01	Belt Cover
Z- 3	Screw Driver		118837-0-01		Z-16- 7	Stud		147856-0-01	Assembly
Z- 4	Screw Driver		101572-1-01		Z-16- 8	Stud		147855-0-01	147895-0-11
Z- 5	Spanner 8×9		100887-0-01		Z-17	Rubber Hinge			
Z- 6	Needle DB×1				Z-18	Head Rest		100477-0-01	
Z- 7	Bobbin		146290-0-01		Z-19	Oil Tank		145277-1-03	
Z- 8	Bobbin Case Sheet				Z-22	Screw			
Z- 9	Screw		100666-0-02		Z-23	Head Cover			
Z-10- 1	Bobbin Winder Wheel Assembly				Z-24- 1	Cap			
Z-10- 2	Screw		100366-0-02		Z-24- 2	Bolt		017502-8-03	
Z-10- 3	Washer				Z-24- 3	Washer		025050-2-33	
Z-10- 4	Bobbin Winder Wheel Shaft Bushing				Z-24- 4	Thread Hanger Assembly		150192-0-01	
Z-10- 5	Bobbin Winder Shaft		117970-0-01		Z-24- 5	Pipe		150172-0-01	
Z-10- 6	Screw		100657-0-01		Z-24- 6-1	Joint		150173-0-01	Z-24-6
Z-10- 7	Bobbin Presser				Z-24- 6-2	Screw		150202-0-01	Joint Assembly
Z-10- 8	Nut				Z-24- 6-3	Nut		021500-1-03	150106-0-01
Z-10- 9	Spring		100401-0-01		Z-24- 7	Spool Shaft		150179-0-01	
Z-10-10	Tension Disc		145446-0-01		Z-24- 8	Spool Cushion		147060-0-01	
Z-10-11	Screw				Z-24- 9	Spool Mat		150182-0-00	
Z-10-12	Bobbin Winder Wheel Guide Bracket Assembly			Z-10 Bobbin Winder Assembly 117963-0-01	Z-24-10	Spool Stand Base		150180-0-00	Z-24
Z-10-13	Bobbin Winder Wheel Bracket				Z-24-11	Spring Washer		028050-2-43	Cotton Stand
Z-10-14	Screw		100659-0-01		Z-24-12	Nut		021500-1-03	Assembly
Z-10-15	Pin				Z-24-13	Spool Holder Assembly		150177-0-01	
Z-10-16	Spring		117969-0-01		Z-24-14	Bolt		017502-8-03	
Z-10-17	Bobbin Presser Arm				Z-24-15	Washer		025050-2-33	
Z-10-18	Pin		100661-0-01		Z-24-16-1	Cotton Stand Base		150189-0-01	Z-24-16
Z-10-19	Bobbin Presser Arm Bracket				Z-24-16-2	Screw		150181-0-01	Cotton Stand Base Assembly
Z-10-20	Screw		009679-3-12		Z-24-17	Screw		031452-2-03	150139-0-01
Z-10-21	Bobbin Winder Wheel Stopper Holder				Z-25	Spanner			
Z-10-22	Bobbin Winder Wheel Stopper		100662-0-01		Z-26	Head Cushion			
Z-11	Magnet		112525-0-00		Z-27	Earth Wire			
Z-12	Oil Pan Cushion				Z-28	Washer			
Z-13	Nail				Z-29	Screw			
Z-14	Head Cushion				Z-30	Movable Knife Case			
Z-15	Hinge				Z-31	Movable Knife			
Z-16- 1	Belt Cover D		147854-0-01	Z-16	Z-32	Screw			
Z-16- 2	Screw		100666-0-02	Belt Cover					
Z-16- 3	Washer		025750-1-34	Assembly					
Z-16- 4	Screw		009680-8-12	147895-0-11					

- * The details of included accessories are subject to change.
- * Änderungen in der Aufstellung der mitgelieferten Zubehöre sind vorbehalten.
- * Les détails des accessoires inclus sont sujets à des changements.
- * Los detalles de los accesorios incluidos pueden variar.

DIFFERENT PARTS LIST

—3.—5

Ref. No.	Name of Parts	-3						-5							
		Sub Class		Motor Spec.		Destination		Sub Class		Motor Spec.		Destination			
		Spain						Spain	England, France					Spain	
A- 4	Screw														
A- 5	Face Plate Thread Guide														
A-14	Pretension Assembly														
A-16	Side Cover														
A-29	Upper Tension Regulator Bracket Assembly														
A-29-4	Thread Take-up Spring														
A-29-8	Tension Spring														
A-31	Tension Release Pin														
A-35	Screw														
A-36	Arm Thread Guide, D														
A-40	Needle Bar Position Pointer														
A-44	Tension Release Crank														
A-45	Spring														
A-46	Screw														
A-47	Thread Guide														
A-48	Nut														
A-49	Pretension Stud														
A-50	Thread Guide Disc														
A-51	Washer														
A-52	Spring														
A-53	Nut														
A-54	Spring														
A-55	Nut														
A-56	Washer														
A-57	Thread Guide Plate														
B- 2	Needle Bar Connecting Rod Assembly						118827-0-01								140883-0-01
B- 3	Thread Take-up Crank						111465-0-00								109205-0-00
B-14	Pulley														115244-0-01
B-33	Lower Shaft														109160-0-01
B-35	Rotary Hook Assembly						143784-0-01								140882-0-01
B-37	Bobbin Case Sheet														140356-0-01
B-38	Bobbin Case														100369-0-01
B-39	Screw														107407-0-02
B-43	Needle Plate						143855-0-01								140715-0-01
B-44	Needle Plate Washer														
B-45	Bobbin Presser Spring														

Ref. No.	Name of Parts	-3						-5					
		Sub Class		Motor Spec.		Destination		Sub Class		Motor Spec.		Destination	
		Spain		Spain	England, France			Spain		Spain		Spain	
C- 8	Needle Feed Eccentric Wheel	180793-0-01						181226-0-01					
C-12	Spring	118710-0-01											
C-22	Needle	100265-0-34				107415 -0-14	107415 -0-18	100265-0-42					
C-23	Needle Bar Thread Guide	112775-0-01											
C-27	Needle Bar Bracket Assembly	140498-0-01				140428-0-01							
C-27- 3	Needle Bar	118685-0-01				140426-0-01							
D- 1	Presser Foot Assembly	141158-0-01				140717-0-01							
D-31	Knee Lifter Assembly												
D-32	Spring												
E- 1	Eccentric Wheel	180791-0-01											
E- 4	Eccentric Wheel	180792-0-01				145269-0-01							
E- 9	Spring	118753-0-01				145643-0-01							
E-12	Reverse Lever	181678-0-01											
E-12- 3	Reverse Lever	118752-0-01											
E-40	Feed Dog	143854-0-01				140716-0-01							
E-58	Feed Rock Shaft Arm	116768-0-01											
F-24	Oil Rejector	144943-0-01											
F-29	Oil Felt	106436-0-01											
F-69	Oil Pan Assembly	181446-2-01											
F-69- 5	Oil Pan	149582-0-01											
F-69-11	Spring												
F-69-12	Knee Lifter Shaft	146035-0-01											
G- 6	Tension Release Solenoid Assembly												
G- 9	Supporter												
G-13	Screw												
G-14	Connector Cap												
G-15	Nylon Connector												
G-16	Thread Trimming Solenoid Assembly												
G-33	Movable Knife												
G-34	Spacer												
G-35	Lower Thread Hinge												
G-44	Cord Holder												
G-45	Tube Holder												
G-46	Tube Holder												
G-47	Tension Release Solenoid Assembly												
G-48	Thread Trimming Solenoid Assembly												

Ref. No.	Name of Parts	-3										-5					
		Sub Class		Motor Spec.		Destination						Spain		Spain		Spain	
		Spain		Spain	England, France							Spain		Spain		Spain	
G-49	Cord Holder																
G-50	Cord Holder																
H-2	Synchronizer Assembly																
H-7	Slip Ring Support																
J-1	Thread-Wiper Solenoid																
J-12	Thread Wiper Solenoid																
K-5	Reverse Solenoid Assembly																
K-7	Connector Cap																
K-8	6P Connector																
K-29	Switch																
K-40	Reverse Solenoid Assembly																
K-41	Switch																
Z-6	Needle		100265-0-34			107415-0-14	107415-0-18							100265-0-42			
Z-8	Bobbin Case Sheet													140356-0-01			
Z-12	Oil Pan Cushion																
Z-13	Nail																
Z-14	Head Cushion																
Z-15	Hinge																
Z-17	Rubber Hinge																
Z-22	Thumb Screw													106120-0-01			
Z-23	Head Cover																
Z-24	Spool Stand Assembly		150150-0-01					150150-0-01							150150-0-01		
Z-25	Spanner																
Z-26	Head Cushion																
Z-27	Earth Wire																
Z-28	Washer																
Z-29	Screw																
Z-30	Movable Knife Case																
Z-31	Movable Knife																
Z-32	Screw																

Ref. No.	Name of Parts	- 103				- 105			
		Brother		Efka		Brother		Efka	
					W. Germany, France				
A- 4	Screw								
A- 5	Face Plate Thread Guide								
A-14	Pretension Assembly								
A-16	Side Cover				118673-0-01				
A-29	Upper Tension Regulator Bracket Assembly		181636-0-01				181776-1-01		
A-29-4	Thread Take-up Spring		100399-0-01				145519-0-01		
A-29-8	Tension Spring		104525-0-01				145153-0-01		
A-31	Tension Release Pin				146065-0-00				
A-35	Screw								
A-36	Arm Thread Guide, D				147862-0-01				
A-40	Needle Bar Position Pointer								
A-44	Tension Release Crank				118763-0-01				
A-45	Spring				118765-0-01				
A-46	Screw				118764-0-01				
A-47	Thread Guide				145524-0-01				
A-48	Nut				021660-1-02				
A-49	Pretension Stud				146056-0-01				
A-50	Thread Guide Disc		147705-0-01				144504-0-01		
A-51	Washer				146206-0-01				
A-52	Spring				146058-0-01				
A-53	Nut				146059-0-01				
A-54	Spring				146060-0-00				
A-55	Nut				105234-0-01				
A-56	Washer				025680-2-34				
A-57	Thread Guide Plate				146055-0-01				
B- 2	Needle Bar Connecting Rod Assembly				147700-0-01				
B- 3	Thread Take-up Crank				148965-0-00				
B-14	Pulley				148823-0-01				
B-33	Lower Shaft				145517-0-01				
B-35	Rotary Hook Assembly		147101-0-01				148846-0-01		
B-37	Bobbin Case Sheet								
B-38	Bobbin Case				148350-1-01				
B-39	Screw				009681-0-12				
B-43	Needle Plate		143855-0-01				148842-0-01		
B-44	Needle Plate Washer						146188-0-01		
B-45	Bobbin Presser Spring				148967-1-01				

Ref. No.	Sub Class Motor Spec. Destination Name of Parts	- 103			- 105			
		Brother		Efka		Brother		Efka
					W. Germany. France			
C- 8	Needle Feed Eccentric Wheel	180793-0-01			181226-0-01			
C-12	Spring	118710-0-01						
C-22	Needle	100265-0-34		107415-0-14	100265-0-42			
C-23	Needle Bar Thread Guide	145944-0-01						
C-27	Needle Bar Bracket Assembly	147702-0-01			148843-0-01			
C-27- 3	Needle Bar	146999-0-01			148844-0-01			
D- 1	Presser Foot Assembly	147703-0-01			140717-0-01			
D-31	Knee Lifter Assembly	181427-0-01						
D-32	Spring							
E- 1	Eccentric Wheel	147860-0-01			180791-0-01			
E- 4	Eccentric Wheel	180792-0-01			145269-0-01			
E- 9	Spring	118753-0-01			145643-0-01			
E-12	Reverse Lever	181678-0-01						
E-12- 3	Reverse Lever	118752-0-01						
E-40	Feed Dog	147100-0-01			148845-0-01			
E-58	Feed Rock Shaft Arm	145508-0-01			116768-0-01			
F-24	Oil Rejector							
F-29	Oil Felt	145751-0-01						
F-69	Oil Pan Assembly	181446-2-01						
F-69- 5	Oil Pan	149582-0-01						
F-69-11	Spring	146038-0-01						
F-69-12	Knee Lifter Shaft	146035-0-01						
G- 6	Tension Release Solenoid Assembly	147107-0-01			147107-0-01			
G- 9	Supporter	140647-0-01						
G-13	Screw	001639-3-12						
G-14	Connector Cap	145596-0-01			145596-0-01			
G-15	Nylon Connector	145681-0-00			145681-0-00			
G-16	Thread Trimming Solenoid Assembly	146014-0-01			146014-0-01			
G-33	Movable Knife	145608-0-01			147981-0-01			
G-34	Spacer	145611-0-00			146187-0-00			
G-35	Lower Thrend Hinge	147102-0-01			145610-1-01			
G-44	Cord Holder							
G-45	Tube Holder							
G-46	Tube Holder							
G-47	Tension Release Solenoid Assembly			148852-0-01			148852-0-01	
G-48	Thread Trimming Solenoid Assembly			146910-0-01			146910-0-01	

Ref. No.	Name of Parts	- 103				- 105			
		Sub Class		Efka		Brother		Efka	
		Motor Spec.	Destination	Brother	W. Germany, France	Brother	W. Germany, France	Brother	W. Germany, France
G-49	Cord Holder								
G-50	Cord Holder								
H-2	Synchronizer Assembly		218931-0-01				218931-0-01		
H-7	Slip Ring Support			148825-0-01				148825-0-01	
J-1	Thread Wiper Solenoid								
J-12	Thread Wiper Solenoid								
K-5	Reverse Solenoid Assembly								
K-7	Connector Cap								
K-8	6P Connector								
K-29	Switch								
K-40	Reverse Solenoid Assembly								
K-41	Switch								
Z-6	Needle		100265-0-34		107415-0-14			100265-0-42	
Z-8	Bobbin Case Sheet								
Z-12	Oil Pan Cushion				146004-0-01				
Z-13	Nail				109714-0-00				
Z-14	Head Cushion				146003-1-01				
Z-15	Hinge				143882-0-01				
Z-17	Rubber Hinge				143910-0-01				
Z-22	Thumb Screw								
Z-23	Head Cover				144222-0-01				
Z-24	Spool Stand Assembly		150150-0-01		150150-0-01		150150-0-01		
Z-25	Spanner				146049-0-01				
Z-26	Head Cushion				145945-0-01				
Z-27	Earth Wire				145946-0-01				
Z-28	Washer				025680-2-34				
Z-29	Screw				009680-6-13				
Z-30	Movable Knife Case				145990-0-01				
Z-31	Movable Knife		145608-0-01				147981-0-01		
Z-32	Screw				141542-0-01				

-200.-300

Ref. No.	Name of Parts	Sub Class	-203	-205	-303		
		Motor Spec.	Efka	Efka	Brother		Efka
		Destination	W. Germany. France				W. Germany. France
A-4	Screw						
A-5	Face Plate Thread Guide						
A-14	Pretension Assembly						
A-16	Side Cover		118673-0-01			148452-0-01	
A-29	Upper Tension Regulator Bracket Assembly		181636-0-01	181776-1-01		181636-0-01	
A-29-4	Thread Take-up Spring		100399-0-01	145519-0-01		100399-0-01	
A-29-8	Tension Spring		104525-0-01	145153-0-01		104525-0-01	
A-31	Tension Release Pin					146065-0-00	
A-35	Screw						
A-36	Arm Thread Guide, D					147862-0-01	
A-40	Needle Bar Position Pointer						
A-44	Tension Release Crank					118763-0-01	
A-45	Spring					118765-0-01	
A-46	Screw					118764-0-01	
A-47	Thread Guide					145524-0-01	
A-48	Nut					021660-1-02	
A-49	Pretension Stud					146056-0-01	
A-50	Thread Guide Disc		147705-0-01	144504-0-01		147705-0-01	
A-51	Washer					146206-0-01	
A-52	Spring					146058-0-01	
A-53	Nut					146059-0-01	
A-54	Spring					146060-0-00	
A-55	Nut					105234-0-01	
A-56	Washer					025680-2-34	
A-57	Thread Guide Plate					146055-0-01	
B-2	Needle Bar Connecting Rod Assembly					147700-0-01	
B-3	Thread Take-up Crank					148965-0-00	
B-14	Pulley					148823-0-01	
B-33	Lower Shaft					145517-0-01	
B-35	Rotary Hook Assembly		147101-0-01	148846-0-01		147101-0-01	
B-37	Bobbin Case Sheet						
B-38	Bobbin Case					148350-1-01	
B-39	Screw					009681-0-12	
B-43	Needle Plate		143855-0-01	148842-0-01		143855-0-01	
B-44	Needle Plate Washer			146188-0-01			
B-45	Bobbin Presser Spring					148967-1-01	

Ref. No.	Name of Parts	Sub Class		Motor Spec.		Destination		-203		-205		-303			
		Efka		Efka		Brother		Efka						W. Germany, France	
			W. Germany, France												
C- 8	Needle Feed Eccentric Wheel	180793-0-01		181226-0-01		180793-0-01									
C-12	Spring	118710-0-01													
C-22	Needle	100265-0-34	107415-0-14	100265-0-42		100265-0-34				107415-0-14					
C-23	Needle Bar Thread Guide					145944-0-01									
C-27	Needle Bar Bracket Assembly	147702-0-01	148843-0-01		147702-0-01				148843-0-01						
C-27- 3	Needle Bar	146999-0-01	148844-0-01		146999-0-01				148844-0-01						
D- 1	Presser Foot Assembly	147703-0-01		140717-0-01		147703-0-01									
D-31	Knee Lifter Assembly					181427-0-01									
D-32	Spring														
E- 1	Eccentric Wheel	147860-0-01		180791-0-01		147860-0-01									
E- 4	Eccentric Wheel	180792-0-01		145269-0-01		180792-0-01									
E- 9	Spring	118753-0-01		145643-0-01		148459-0-01									
E-12	Reverse Lever	181678-0-01				181714-0-01									
E-12- 3	BReverse Lever	118752-0-01				148458-0-01									
E-40	Feed Dog	147100-0-01		148845-0-01		147100-0-01									
E-58	Feed Rock Shaft Arm	145508-0-01		116768-0-01		145508-0-01									
F-24	Oil Rejector														
F-29	Oil Felt					145751-0-01									
F-69	Oil Pan Assembly					181446-2-01									
F-69- 5	Oil Pan					149582-0-01									
F-69-11	Spring					146038-0-01									
F-69-12	Knee Lifter Shaft					146035-0-01									
G- 6	Tension Release Solenoid Assembly					147107-0-01									
G- 9	Supporter														
G-13	Screw	001639-3-12													
G-14	Connector Cap					145596-0-01									
G-15	Nylon Connector					145681-0-00									
G-16	Thread Trimming Solenoid Assembly					146014-0-01									
G-33	Movable Knife	145608-0-01		147981-0-01		145608-0-01									
G-34	Spacer	145611-0-00		146187-0-00		145611-0-00									
G-35	Lower Thread Hinge	147102-0-01		145610-1-01		147102-0-01									
G-44	Cord Holder					148462-0-01									
G-45	Tube Holder					142268-0-01									
G-46	Tube Holder	142268-0-01													
G-47	Tension Release Solenoid Assembly	148852-0-01				148852-0-01									
G-48	Thread Trimming Solenoid Assembly	146910-0-01				146910-0-01									

Ref. No.	Name of Parts	Sub Class		-203		-205		-303			
		Motor Spec.		Efka		Efka		Brother		Efka	
		Destination		W. Germany, France						W. Germany, France	
G-49	Cord Holder										
G-50	Cord Holder										
H-2	Synchronizer Assembly							218931-0-01			
H-7	Slip Ring Support			148825-0-01						148825-0-01	
J-1	Thread Wiper Solenoid			150805-0-01							
J-12	Thread Wiper Solenoid										
K-5	Reverse Solenoid Assembly							147756-0-01			
K-7	Connector Cap							145596-0-01			
K-8	6P Connector							146118-0-00			
K-29	Switch							146121-0-00			
K-40	Reverse Solenoid Assembly									147757-0-01	
K-41	Switch									146913-0-00	
Z-6	Needle	100265-0-34	107415-0-14	100265-0-42				100265-0-34			107415-0-14
Z-8	Bobbin Case Sheet										
Z-12	Oil Pan Cushion							146004-0-01			
Z-13	Nail							109714-0-00			
Z-14	Head Cushion							146003-1-01			
Z-15	Hinge							143882-0-01			
Z-17	Rubber Hinge							143910-0-01			
Z-22	Thumb Screw										
Z-23	Head Cover							144222-0-01			
Z-24	Spool Stand Assembly			150150-0-01				150150-0-01			150150-0-01
Z-25	Spanner							146049-0-01			
Z-26	Head Cushion							145945-0-01			
Z-27	Earth Wire							145946-0-01			
Z-28	Washer							025680-2-34			
Z-29	Screw							009680-6-13			
Z-30	Movable Knife Case							145990-0-01			
Z-431	Movable Knife			145608-0-01		147981-0-01		145608-0-01			
Z-32	Screw							141542-0-01			

-400.-500

Ref. No.	Name of Parts	-403			-503			-505
		Efka			Efka			Efka
		W. Germany, France	U.S.A., Canada		W. Germany, France	U.S.A., Canada		
A-4	Screw							
A-5	Face Plate Thread Guide							
A-14	Pretension Assembly							
A-16	Side Cover			148452-0-01				
A-29	Upper Tension Regulator Bracket Assembly			181636-0-01			181776-1-01	
A-29-4	Thread Take-up Spring			100399-0-01			145519-0-01	
A-29-8	Tension Spring			104525-0-01			145153-0-01	
A-31	Tension Release Pin			146065-0-00				
A-35	Screw							
A-36	Arm Thread Guide, D			147862-0-01				
A-40	Needle Bar Position Pointer							
A-44	Tension Release Crank			118763-0-01				
A-45	Spring			118765-0-01				
A-46	Screw			118764-0-01				
A-47	Thread Guide			145524-0-01				
A-48	Nut			021660-1-02				
A-48	Pretension Stud			146056-0-01				
A-50	Thread Guide Disc			147705-0-01			144504-0-01	
A-51	Washer			146206-0-01				
A-52	Spring			146058-0-01				
A-53	Nut			146059-0-01				
A-54	Spring			146060-0-01				
A-55	Nut			105234-0-01				
A-56	Washer			025680-2-34				
A-57	Thread Guide Plate			146055-0-01				
B-2	Needle Bar Connecting Rod Assembly			147700-0-01				
B-3	Thread Take-up Crank			148965-0-00				
B-14	Pulley			148823-0-01				
B-33	Lower Shaft			145517-0-01				
B-35	Rotary Hook Assembly			147101-0-01			148846-0-01	
B-37	Bobbin Case Sheet							
B-38	Bobbin Case			148350-1-01				
B-39	Screw			009681-0-12				
B-43	Needle Plate			143855-0-01			148842-0-01	
B-44	Needle Plate Washer						146188-0-01	
B-45	Bobbin Presser Spring			148967-1-01				

Ref. No.	Name of Parts	-403			-503			-505
		Efka			Efka			Efka
		W. Germany, France	U.S.A., Canada		W. Germany, France	U.S.A., Canada		
C- 8	Needle Feed Eccentric Wheel	180793-0-01						181226-0-01
C-12	Spring	118710-0-01						
C-22	Needle	100265-0-34	107415-0-14	100265-0-34	107415-0-14	100265-0-34	100265-0-42	
C-23	Needle Bar Thread Guide	145944-0-01						
C-27	Needle Bar Bracket Assembly	147702-0-01	148843-0-01	147702-0-01	148843-0-01	147702-0-01	148843-0-01	
C-27- 3	Needle Bar	146999-0-01	148844-0-01	146999-0-01	148844-0-01	146999-0-01	148844-0-01	
D- 1	Presser Foot Assembly	147703-0-01						140717-0-01
D-31	Knee Lifter Assembly	181427-0-01						
D-32	Spring	146985-0-01						
E- 1	Eccentric Wheel	147860-0-01						180791-0-01
E- 4	Eccentric Wheel	180792-0-01						145269-0-01
E- 9	Spring	148459-0-01			145643-0-01			
E-12	Reverse Lever	181714-0-01						
E-12- 3	Reverse Lever	148458-0-01						
E-40	Feed Dog	147100-0-01						148845-0-01
E-58	Feed Rock Shaft Arm	145508-0-01						116768-0-01
F-24	Oil Rejector							
F-29	Oil Felt	145751-0-01						
F-69	Oil Pan Assembly	181446-2-01			181761-2-01			
F-69- 5	Oil Pan	149582-0-01			149583-0-01			
F-69-11	Spring	146038-0-01						
F-69-12	Knee Lifter Shaft	146035-0-01			149007-0-01			
G- 6	Tension Release Solenoid Assembly							
G- 9	Supporter							
G-12	Screw							
G-14	Connector Cap							
G-15	Nylon Connector							
G-16	Thread Trimming Solenoid Assembly							
G-33	Movable Knife	145608-0-01						147981-0-01
G-34	Spacer	145611-0-00						146187-0-00
G-35	Lower Thread Hinge	147102-0-01						145610-1-01
G-44	Cord Holder	148462-0-01						
G-45	Tube Holder							
G-46	Tube Holder							
G-47	Tension Release Solenoid Assembly	148852-0-01	151247-0-01	148852-0-01	151247-0-01	148852-0-01	148852-0-01	
G-48	Thread Trimming Solenoid Assembly	146910-0-01	151187-0-01	146910-0-01	151187-0-01	146910-0-01	146910-0-01	

Ref. No.	Name of Parts	- 403			- 503			- 505
		Efka		U.S.A., Canada	Efka		U.S.A., Canada	Efka
		W. Germany, France			W. Germany, France			
G-49	Cord Holder	148856-0-01						
G-50	Cord Holder				148462-0-01			
H-2	Synchronizer Assembly							
H-7	Slip Ring Support	148825-0-01						
J-1	Thread Wiper Solenoid	150805-0-01		150805-0-01			150805-0-01	
J-12	Thread Wiper Solenoid		151248-0-01			151248-0-01		
K-5	Reverse Solenoid Assembly							
K-7	Connector Cap							
K-8	6P Connector							
K-29	Switch							
K-40	Reverse Solenoid Assembly	147757-0-01		151181-0-01				
K-41	Switch	146913-0-00		151185-0-01	146913-0-00	151185-0-01	146913-0-00	
Z-6	Needle	100265-0-34	107415-0-14	100265-0-34	107415-0-14	100265-0-34	100265-0-42	
Z-8	Bobbin Case Sheet							
Z-12	Oil Pan Cushion	146004-0-01						
Z-13	Nail	109714-0-00						
Z-14	Head Cushion	146003-1-01						
Z-15	Hinge	143882-0-01						
Z-17	Rubber Hinge	143910-0-01						
Z-22	Thumb Screw							
Z-23	Head Cover	144222-0-01						
Z-24	Spool Stand Assembly	150150-0-01						
Z-25	Spanner	146049-0-01						
Z-26	Head Cushion	145945-0-01						
Z-27	Earth Wire	145946-0-01						
Z-28	Washer	025680-2-34						
Z-29	Screw	009680-6-13						
Z-30	Movable Knife Case	145990-0-01						
Z-31	Movable Knife	145608-0-01						147981-0-01
Z-32	Screw	141542-0-01						

Ref. No.	Name of Parts	-603					-605					
		Brother		Efka			Brother		Efka			U.S.A., Canada
					W. Germany, France	U.S.A., Canada						
A-4	Screw											
A-5	Face Plate Thread Guide											
A-14	Pretension Assembly											
A-16	Side Cover					148452-0-01						
A-29	Upper Tension Regulator Bracket Assembly				181636-0-01					181776-1-01		
A-29-4	Tread Take-up Spring				100399-0-01					145519-0-01		
A-29-8	Tension Spring				104525-0-01					145153-0-01		
A-31	Tension Release Pin											
A-35	Screw											
A-36	Arm Thread Guide, D					147862-0-01						
A-40	Needle Bar Position Pointer											
A-44	Tension Release Crank											
A-45	Spring											
A-46	Screw											
A-47	Thread Guide					145524-0-01						
A-48	Nut					021660-1-02						
A-49	Pretension Stud					146056-0-01						
A-50	Thread Guide Disc				147705-0-01					144504-0-01		
A-51	Washer					146206-0-01						
A-52	Spring					146058-0-01						
A-53	Nut					146059-0-01						
A-54	Spring					146060-0-00						
A-55	Nut					105234-0-01						
A-56	Washer					025680-2-34						
A-57	Thread Guide Plate					146055-0-01						
B-2	Needle Bar Connecting Rod Assembly					147700-0-01						
B-3	Thread Take-up Crank					148965-0-00						
B-14	Pulley					148823-0-01						
B-33	Lower Shaft					145517-0-01						
B-35	Rotary Hook Assembly				147101-0-01					148846-0-01		
B-37	Bobbin Case Sheet											
B-38	Bobbin Case					148350-1-01						
B-39	Screw					009681-0-12						
B-43	Needle Plate				143855-0-01					148842-0-01		
B-44	Needle Plate Washer					146188-0-01						
B-45	Bobbin Presser Spring					148967-1-01						

Ref. No.	Name of Parts	-603					-605								
		Sub Class		Motor Spec.			Destination		Brother		Efka			U.S.A., Canada	
		Brother	Efka	W. Germany, France	U.S.A., Canada	Brother	Efka	U.S.A., Canada	Brother	Efka	U.S.A., Canada				
C- 8	Needle Feed Eccentric Wheel	180793-0-01					181226-0-01								
C-12	Spring	118710-0-01													
C-22	Needle	100265-0-34		107415 -0-14	100265 -0-34	100265-0-42									
C-23	Needle Bar Thread Guide	145944-0-01													
C-27	Needle Bar Bracket Assembly	147702-0-01		148843 -0-01	147702 -0-01	148843-0-01									
C-27- 3	Needle Bar	146999-0-01		148844 -0-01	146999 -0-01	148844-0-01									
D- 1	Presser Foot Assembly	147703-0-01					140717-0-01								
D-31	Knee Lifter Assembly														
D-32	Spring	146985-0-01													
E- 1	Eccentric Wheel	147860-0-01					180791-0-01								
E- 4	Eccentric Wheel	180792-0-01					145269-0-01								
E- 9	Spring	145643-0-01													
E-12	Reverse Lever	181714-0-01													
E-12- 3	Reverse Lever	148458-0-01													
E-40	Feed Dog	147100-0-01					148845-0-01								
E-58	Feed Rock Shaft Arm	145508-0-01					116768-0-01								
F-24	Oil Rejector														
F-29	Oil Felt	145751-0-01													
F-69	Oil Pan Assembly	181761-2-01													
F-69- 5	Oil Pan	149583-0-01													
F-69-11	Spring														
F-69-12	Knee Lifter Shaft	149007-0-01													
G- 6	Tension Release Solenoid Assembly	147107-0-01				147107-0-01									
G- 9	Supporter														
G-13	Screw														
G-14	Connector Cap	145596-0-01				145596-0-01									
G-15	Nylon Connector	145681-0-00				145681-0-00									
G-16	Thread Trimming Solenoid Assembly	146014-0-01				146014-0-01									
G-33	Movable Knife	145608-0-01					147981-0-01								
G-34	Spacer	145611-0-00					146187-0-00								
G-35	Lower Thread Hinge	147102-0-01					145610-1-01								
G-44	Cord Holder														
G-45	Tube Holder														
G-46	Tube Holder	142268-0-01													
G-47	Tension Release Solenoid Assembly			148852-0-01	151247 -0-01			148852-0-01	151247 -0-01						
G-48	Thread Trimming Solenoid Assembly			146910-0-01	151187 -0-01			146910-0-01	151187 -0-01						

Ref. No.	Sub Class Motor Spec. Destination Name of Parts	-603				-605				
		Brother		Efka		Brother		Efka		U.S.A., Canada
				W. Germany, France	U.S.A., Canada					
G-49	Cord Holder									
G-50	Cord Holder									
H-2	Synchronizer Assembly	218931-0-01				218931-0-01				
H-7	Slip Ring Support			148825-0-01				148825-0-01		
J-1	Thread Wiper Solenoid									
J-12	Thread Wiper Solenoid									
K-5	Reverse Solenoid Assembly									
K-7	Connector Cap									
K-8	6P Connector									
K-29	Switch	146121-0-00				146121-0-00				
K-40	Reverse Solenoid Assembly									
K-41	Switch			146913-0-00	151185 -0-01			146913-0-00	151185 -0-01	
Z-6	Needle		100265-0-34	107415 -0-14	100265 -0-34			100265-0-42		
Z-8	Bobbin Case Sheet									
Z-12	Oil Pan Cushion					146004-0-01				
Z-13	Nail					109714-0-00				
Z-14	Head Cushion					146003-1-01				
Z-15	Hinge					143882-0-01				
Z-17	Rnbber Hinge					143910-0-01				
Z-22	Thumb Screw									
Z-23	Head Cover					144222-0-01				
Z-24	Spool Stand Assembly		150150-0-01		150150-0-01			150150-0-01		150150 -0-01
Z-25	Spanner					146049-0-01				
Z-26	Head Cushion					145945-0-01				
Z-27	Earth Wire					145946-0-01				
Z-28	Washer					025680-2-34				
Z-29	Screw					009680-6-13				
Z-30	Movable Knife Case					145990-0-01				
Z-31	Movable Knife			145608-0-01				147981-0-01		
Z-32	Screw					141542-0-01				

a. Exclusive Parts

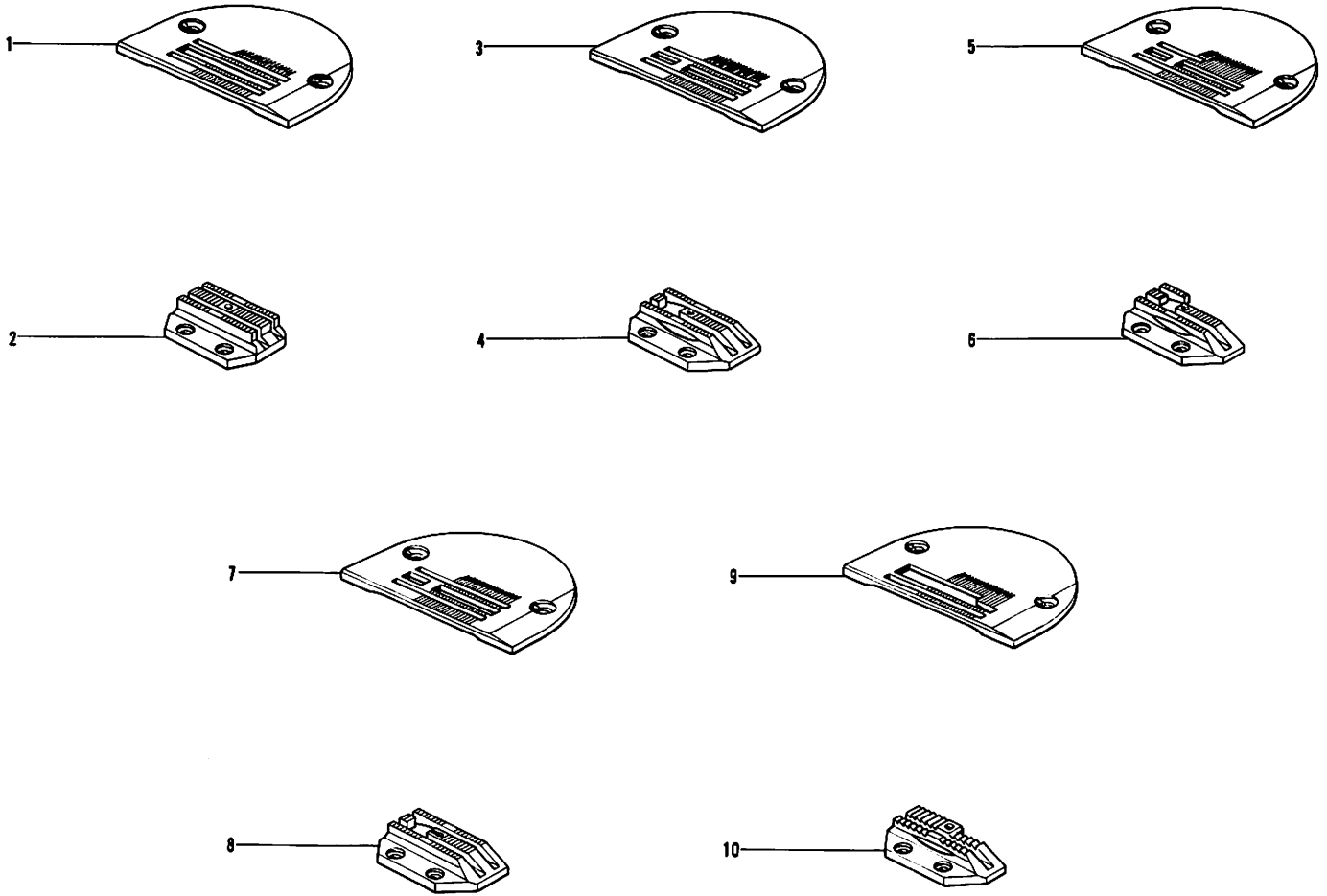

Ref. No.	Name of Parts	Q'ty	Parts No.	Use	Ref. No.	Name of Parts	Q'ty	Parts No.	Use
a- 1	Needle Plate	1	147954-0-01	Medium Thick	a- 6	Feed Dog	1	148301-0-01	Medium Thick
a- 2	Feed Dog	1	147955-0-01		a- 7	Needle Plate	1	143857-0-01	
a- 3	Needle Plate	1	143857-0-01		a- 8	Feed Dog	1	143856-0-01	
a- 4	Feed Dog	1	147956-0-01		a- 9	Needle Plate	1	148842-0-01	
a- 5	Needle Plate	1	148300-0-01		a-10	Feed Dog	1	151053-0-01	Thick

INDEX

Parts No.	Ref. No.	Remark	Parts No.	Ref. No.	Remark	Parts No.	Ref. No.	Remark	Parts No.	Ref. No.	Remark	
001061-6-06	L-12-6		013760-6-10	C-10		047601-8-42	D-28		104564-0-01	E-12-4		
001639-3-12	G-13		013760-8-10	B-11-2		048030-3-42	G-22			F-20		
001670-5-14	J-9			E-1-2		048040-3-42	D-16		104566-0-01	F-27		
001670-8-14	D-2			E-4-2			E-25-8			104619-0-02	D-31-3	
002301-0-03	M-1-14			E-6			K-3			104821-0-01	A-26	
002303-0-06	M-3			E-27			K-22			104829-0-01	A-42	
002501-0-64	M-1-6		E-31-2		K-39				104830-0-01	A-43		
	M-1-19		013760-8-12	D-18		L-5		104832-0-01	A-17			
007500-8-12	K-6		013761-4-10	B-1		048070-3-42	E-7		104885-0-01	E-69-9		
007501-2-02	K-1			B-7		048080-3-42	K-26		104908-0-01	E-45		
008400-5-64	M-1-2			B-9		081002-6-70	F-13		105234-0-01	A-55		
009660-3-02	F-7			B-15		081007-0-70	F-69-3			E-8-2		
009660-7-12	G-26			B-24		081014-6-70	F-16		106120-0-01	Z-22		
009670-4-12	F-3			C-18		100022-0-04	F-69-8		106436-0-01	F-29		
009670-5-12	F-8			C-27-10		100032-0-03	B-42		107155-0-01	F-21		
	F-50		013770-7-10	B-5		100058-0-03	C-2		107407-0-02	B-39		
	F-54			B-18-2		100080-0-03	E-39		107415-0-14	C-22		
009670-5-13	K-32			B-18-4		100134-0-01	A-29-7			Z-6		
009670-6-12	G-8			B-25-2		100136-0-01	A-29-9		108520-0-01	A-19		
	J-4			B-25-4		100260-0-01	C-5		108549-0-01	E-17-2		
	J-5			E-59			C-20		108749-0-01	E-32		
009670-6-14	A-28		014680-6-22	G-40		100265-0-34	C-22		108801-0-01	F-25		
009670-8-12	A-15		014770-6-22	C-26-2			A-7		108802-0-01	F-30		
	F-65-9		015771-0-12	E-13		100265-0-42	C-22			F-56		
	J-2		017502-8-03	Z-24-2			Z-6		108960-0-02	A-4		
009671-0-12	D-6-2			Z-24-14		100327-0-01	E-16		109151-0-01	E-17-1		
009671-4-13	A-1		017671-8-12	C-27-8		100328-0-01	E-15		109153-0-01	E-35		
009671-4-14	F-42		017762-0-13	D-31-1			F-61		109160-0-01	B-33		
009671-8-13	A-2			L-10		100366-0-02	Z-10-2		109171-0-01	F-26		
009679-3-12	F-28		021060-2-06	L-12-4		100369-0-01	B-38		109173-0-01	B-34		
	G-27		021300-1-03	M-1-10		100399-0-01	A-29-4		109205-0-00	B-3		
	Z-10-20			M-6		100401-0-01	Z-10-9		109268-0-01	L-12-14		
009680-6-12	G-30		021500-1-03	Z-24-6-3		100402-0-04	A-29-1		109405-0-01	F-41		
	G-42			Z-24-12		100463-0-01	D-31-4		109714-0-00	Z-13		
009680-6-13	Z-29		021500-1-04	L-12-10			L-9		110087-0-01	D-31-5		
009680-7-12	D-27		021500-1-63	M-1-9		100477-0-01	Z-18		110161-0-02	D-22		
	G-17		021660-1-02	A-48		100657-0-01	Z-10-6		110367-0-01	B-6		
009680-7-13	A-9		021670-2-03	C-27-7		100659-0-01	Z-10-14		110436-0-01	Z-1		
	F-68			F-45		100661-0-01	Z-10-18		110488-0-01	C-11-4		
009680-7-14	E-18		021760-3-02	K-16		100662-0-01	Z-10-22		110562-0-01	C-7-2		
009680-8-12	Z-16-4		025030-1-33	M-1-13		100666-0-02	M-8			C-11-5		
009681-0-12	B-39		025030-2-33	M-4			Z-9		110563-0-01	C-7-3		
	C-11-1		025030-3-35	H-2-3			Z-16-2		110711-0-01	C-29		
009681-0-13	G-11		025040-1-35	H-2-9		100887-0-01	Z-5		111194-0-01	F-39		
009681-0-14	A-13			H-2-15		101482-0-01	E-3		111465-0-00	B-3		
009681-2-12	E-46		025040-3-35	G-19		101487-0-00	F-12		111466-0-01	D-3		
	E-57			H-2-6		101572-1-01	Z-4		111467-0-01	D-4		
009681-4-14	K-28		025050-2-33	L-12-11		101706-0-01	C-8-2		111468-0-01	B-2-1		
009681-6-12	E-55-2			Z-24-3			C-11-6		111476-0-01	A-5		
009711-2-12	C-6			Z-24-15			E-42		111863-0-01	F-38		
	C-14		025060-2-36	L-12-7			E-51		111865-0-01	F-31		
	E-49		025060-3-35	H-2-11			E-53		112072-0-01	E-11		
009711-4-12	H-1		025100-1-30	E-29			E-54-2		112467-0-02	F-65-1		
009761-4-12	K-12		025680-1-33	G-36		101706-0-03	B-22-2		112525-0-00	Z-11		
009781-4-12	H-5		025680-2-34	A-56			B-28-2		112744-0-01	F-51		
011681-2-12	B-30			Z-28		102538-0-02	F-19		112751-0-02	A-35		
	E-8-3		025750-1-34	Z-16-3		102716-0-03	A-14-5		112775-0-01	C-23		
011711-4-12	A-34		028030-2-43	M-1-11			G-2		112782-0-01	F-1		
013679-4-12	C-17			M-5		102921-0-02	D-19		113316-0-01	A-27		
013680-6-12	K-23		028040-2-43	L-12-3		103950-0-02	A-30		114294-0-01	A-29-3		
	A-10		028050-2-43	M-1-8		104449-0-01	A-6		114561-0-01	B-41-2		
013680-8-12	B-32			M-1-20		104450-0-01	A-7		114931-0-01	A-11		
	F-57			Z-24-11		104464-0-01	B-4		114966-0-01	D-31-7		
013689-4-12	E-21		028060-2-34	H-2-12		104478-0-01	B-13		114967-0-01	D-31-6		
	E-23		028060-2-40	L-1		104520-1-00	B-26		115018-0-01	M-9		
	E-25-4			L-12-5		104521-0-02	C-26-1		115244-0-01	B-14		
	E-34		028060-2-42	K-13		104525-0-01	A-29-8		115663-0-01	E-38		
	F-24-2		028680-2-42	Z-16-5		104546-0-01	F-18		116112-0-01	A-33		
013760-6-10	B-17		031452-2-03	Z-24-17		104547-0-01	F-17		116735-0-00	B-2-3		
	B-20		047300-8-42	G-18		104555-0-01	F-14		116743-0-01	D-9		

Parts No.	Ref. No.	Remark	Parts No.	Ref. No.	Remark	Parts No.	Ref. No.	Remark	Parts No.	Ref. No.	Remark
116744-0-01	D-10		118747-0-01	E-33		140757-0-01	B-40		145153-0-01	A-29-8	
116746-0-01	D-15		118748-0-01	E-30		140882-0-01	B-35		145269-0-01	E-4	
116748-0-01	D-23		118751-0-01	E-12-1		140883-0-01	B-2		145277-1-03	Z-19	
116751-0-01	D-26		118752-0-01	E-12-3		140885-0-01	A-8		145446-0-01	A-29-6	
116752-0-01	D-20		118753-0-01	E-9		140947-0-01	L-12-1			Z-10-10	
116766-0-01	E-41		118758-0-01	E-2		140948-0-01	M-2-1		145465-0-01	B-2-5	
	E-52		118759-0-01	B-22		140950-0-00	M-2-4		145508-0-01	E-58	
116768-0-01	E-58		118761-1-00	B-31		140953-0-01	L-12-12		145510-0-00	E-44	
116794-0-01	F-23		118762-0-00	B-29		141158-0-01	D-1		145517-0-01	B-33	
116798-0-01	D-30		118763-0-01	A-44		141207-0-01	D-13		145524-0-01	A-47	
116799-0-01	F-35		118764-0-01	A-46		141208-0-01	D-11		145534-0-01	F-22	
116917-0-01	E-36		118765-0-01	A-45		141331-0-01	K-17		145589-1-01	G-38	
116919-0-01	E-50		118766-0-01	A-36			K-20-2		145591-0-01	A-29-4	
116920-0-01	E-43		118767-0-01	A-3		141343-0-02	K-14		145595-0-01	G-41	
116922-0-01	A-29-5		118768-0-01	F-46		141494-0-01	K-18		145596-0-01	G-14	
117211-0-01	D-25			F-48		141542-0-01	Z-32			K-7	
117666-0-01	A-39			F-53		141598-0-01	K-36			M-1-22-3	
117963-0-01	Z-10		118770-0-01	F-33		141728-0-01	D-8		145601-0-01	G-31	
117969-0-01	Z-10-16		118777-0-01	F-2		142037-0-00	M-1-18-7		145608-0-01	G-33	
117970-0-01	Z-10-5		118778-0-01	F-11		142038-0-01	M-1-18-8			Z-31	
118672-0-01	A-22		118779-0-01	F-10		142268-0-01	G-45		145610-1-01	G-35	
118673-0-01	A-16		118781-0-01	F-4			G-46		145611-0-00	G-34	
118674-0-01	A-12		118782-0-01	F-5		142274-0-01	A-41		145617-0-01	G-25	
118675-0-01	A-18		118783-0-01	F-44		142349-0-00	M-1-5-2		145618-0-01	G-23	
118677-0-01	B-12		118784-0-01	F-43		142425-0-01	C-27-6		145619-0-01	G-24	
118678-0-01	B-8		118785-0-00	A-37		142443-0-01	Z-2		145620-0-01	G-21	
118682-0-01	A-40		118786-0-01	F-6		142482-0-01	E-17-3		145621-0-01	G-20	
118685-0-01	C-27-3		118788-0-01	F-55		142572-0-01	E-56		145623-0-01	G-28	
118686-0-01	C-27-2		118824-0-01	E-31		142573-0-01	E-47		145643-0-01	E-9	
118687-0-01	C-27-1		118827-0-01	B-2		142708-0-00	B-19		145681-0-00	G-15	
118688-0-01	C-27-5		118829-0-01	B-2-4		142709-0-00	B-23		145751-0-01	F-29	
118689-0-01	C-27-4		118837-0-01	Z-3		142746-0-02	E-17-4		145933-0-01	G-29	
118690-0-01	C-27-11		118865-0-01	E-19		142747-0-02	E-17-5		145944-0-01	C-23	
118691-0-01	C-25		118996-0-00	F-60		143196-0-01	F-15		145945-0-01	Z-26	
118692-0-01	C-28		120263-0-01	G-4		143488-0-01	M-2-6		145946-0-01	Z-27	
118693-0-01	C-1		121007-0-01	B-27		143489-0-01	M-2-5		145951-0-01	C-26	
118696-0-00	C-3		121823-0-01	G-7		143549-0-00	G-6-2		145990-0-01	Z-30	
118698-0-01	C-27-4		122771-0-01	B-41-1			G-16-3		146003-1-01	Z-14	
118698-1-01	C-7		140320-0-00	F-52			K-5-5		146004-0-01	Z-12	
118699-0-01	C-7-5		140356-0-01	B-37			K-29-3		146014-0-01	G-16	
118700-0-01	C-7-4			Z-8			M-1-22-2		146035-0-01	F-69-12	
118703-0-01	C-11		140357-0-01	F-36			M-2-3		146037-0-01	F-69-7	
118705-0-01	C-11-2		140361-0-01	F-47		143784-0-01	B-35		146038-0-01	F-69-11	
118706-0-01	C-11-8		140407-0-01	D-7		143854-0-01	E-40		146039-0-01	D-31-2	
118707-0-01	C-9		140412-0-01	F-34		143855-0-01	B-43			L-11	
118708-0-01	C-19		140426-0-01	C-27-3		143856-0-01	a-8		146040-0-01	F-69-1	
118709-0-01	C-11-7		140428-0-01	C-27		143857-0-01	a-3		146049-0-01	Z-25	
118710-0-01	C-12		140438-0-01	F-37			a-7		146055-0-01	A-57	
118712-0-01	C-15		140480-0-01	F-69-4		143882-0-01	Z-15		146056-0-01	A-49	
118713-0-01	C-16		140498-0-01	C-27		143910-0-01	Z-17		146058-0-01	A-52	
	E-20		140503-0-01	D-31-8		143959-1-03	M-1-5		146059-0-01	A-53	
118718-0-01	D-5		140518-0-01	F-69-2		143960-1-01	M-1-5-3		146060-0-00	A-54	
118719-0-01	D-17		140538-0-00	M-1-18-2		143962-0-01	M-1-5-4		146065-0-00	A-31	
118720-0-01	D-14		140539-0-00	M-1-18-5		144189-0-01	M-7		146080-0-00	G-43	
118723-0-01	D-29		140540-0-00	M-1-4		144222-0-01	Z-23			K-31	
118725-0-01	E-5		140542-0-01	M-1-18-4		144458-0-01	J-10		146103-0-01	K-5-1	
118727-0-01	E-25		140543-0-00	M-1-18-6		144502-0-01	A-14		146104-0-00	K-5-2	
118729-0-01	E-25-3		140553-0-01	C-24		144504-0-01	A-14-3		146114-0-01	K-24	
118730-0-01	E-25-1		140627-0-01	L-6			A-50		146115-0-00	K-21	
118731-0-01	E-25-9		140643-0-00	K-29-1		144505-0-00	A-14-4		146118-0-00	K-8	
118732-0-01	E-25-6		140647-0-01	G-9		144712-0-01	E-5-2			M-1-22-4	
118733-0-01	E-25-7			J-3		144741-0-01	A-29-2		146121-0-00	K-29	
118734-0-01	E-26		140668-0-01	L-8		144868-0-01	B-21		146122-0-00	K-29-2	
118735-0-01	E-28		140678-0-00	M-1-5-5		144869-0-01	F-65-7		146124-0-01	K-30	
118736-0-01	E-24		140682-0-01	M-1-18-1		144872-0-01	F-67		146125-0-01	K-27	
118737-0-01	E-25-2		140704-0-01	A-23		144874-0-01	F-65-8		146128-0-00	K-25-2	
118740-0-01	E-22		140715-0-01	B-43		144875-0-01	F-65-3		146148-0-01	K-38	
118741-0-01	E-8		140716-0-01	E-40		144876-0-01	F-65-2		146149-0-01	K-35	
118744-0-01	E-8-1		140717-0-01	D-1		144878-0-01	F-65-4		146156-0-01	K-33	
118746-0-01	E-10		140726-0-00	B-10		144943-0-01	F-24		146157-0-01	L-3	

Parts No.	Ref. No.	Remark	Parts No.	Ref. No.	Remark	Parts No.	Ref. No.	Remark	Parts No.	Ref. No.	Remark
146160-0-01	M- 2		148452-0-01	A -16		180791-0-01	E - 1				
146171-0-00	M- 1- 3		148453-0-01	K -11		180792-0-01	E - 4				
146175-0-01	L -12		148454-0-01	K - 9		180793-0-01	C - 8				
146178-0-01	L -12-13		148455-0-01	K -19		180952-0-01	D - 6				
146187-0-00	G -34		148456-0-01	K -15		181226-0-01	C - 8				
146188-0-01	B -44		148457-0-01	K -20- 1		181427-0-01	D -31				
146196-0-01	F -66		148458-0-01	E -12- 3		181446-2-01	F -69				
146206-0-01	A -51		148459-0-01	E - 9		181476-1-01	E -65				
146288-0-01	J - 8		148460-0-01	K -25		181482-0-01	E -17				
146290-0-01	B -36		148461-0-01	K -25- 1		181523-0-01	E -37				
	Z - 7		148462-0-01	G -44		181636-0-01	A -29				
146293-0-01	F -69- 6			G -50		181640-0-01	F - 9				
146319-0-01	F -64		148465-0-00	K - 2		181678-0-01	E -12				
146323-0-00	F -62		148467-0-01	K -20		181714-0-01	E -12				
146324-0-01	F -63		148823-0-01	B -14		181761-2-01	F -69				
146326-0-01	F -59		148825-0-01	H - 7		181776-0-01	A -29				
146329-0-00	F -58		148842-0-01	B -43		181994-0-01	B -11				
146331-0-01	B -16			a - 9		181995-0-01	B -28				
146358-0-01	L -12-15		148843-0-01	C -27		206755-0-00	M- 1-21				
146360-0-02	K -10		148844-0-01	C -27- 3		212251-0-01	L -12- 2				
146367-0-01	F -69-10		148845-0-01	E -40		215080-0-01	H - 2-10				
146398-0-01	F -49		148846-0-01	B -35			H - 2-16				
146581-0-01	C - 4		148848-0-01	F -65- 5		215083-0-01	H - 2- 2				
	C -21		148849-0-01	F -65- 6		216332-0-01	H - 4				
146910-0-01	G -48		148852-0-01	G -47		216880-0-01	H - 2-13				
146913-0-00	K -41		148853-0-01	K -34		217093-0-01	H - 2- 7				
146985-0-01	D -32		148854-0-01	K -37		218931-0-01	H - 2				
146986-0-01	L - 7		148856-0-01	G -49		218944-0-01	H - 3				
146999-0-01	C -27- 3		148965-0-00	B - 3		218953-0-01	H - 2- 8				
147060-0-01	Z -24- 8		148967-1-01	B -45							
147100-0-01	E -40		149007-0-01	F -69-12							
147101-0-01	B -35		149539-1-01	M- 1							
147102-0-01	G -35		149543-0-01	M- 1-18							
147103-0-01	G - 1		149544-0-01	M- 1-18-3							
147104-0-01	G - 3		149545-0-01	M- 1-22							
147106-0-01	G - 5		149547-0-00	M- 1-12							
147107-0-01	G - 6		149548-0-01	L - 4							
147110-1-01	G -10		149578-0-00	F -69-13							
147141-0-01	L - 2		149582-0-01	F -69- 5							
147697-0-01	G -39		149583-0-01	F -69- 5							
147700-0-01	B - 2		150106-0-01	Z -24- 6							
147702-0-01	C -27		150139-0-01	Z -24-16							
147703-0-01	D - 1		150150-0-01	Z -24							
147705-0-01	A -50		150172-0-01	Z -24- 5							
147754-0-01	K - 4		150173-0-01	Z -24-6-1							
147756-0-01	K - 5		150177-0-01	Z -24-13							
147757-0-01	K -40		150179-0-01	Z -24- 7							
147846-0-01	D -12		150180-0-00	Z -24-10							
147849-0-01	Z -16- 6		150181-0-01	Z -24-16-2							
147854-0-01	Z -16- 1		150182-0-00	Z -24- 9							
147855-0-01	Z -16- 8		150189-0-01	Z -24-16-1							
147856-0-01	Z -16- 7		150192-0-01	Z -24- 4							
147860-0-01	E - 1		150202-0-01	Z -24- 6-2							
147862-0-01	A -36		150305-0-01	F -40							
147891-0-00	A -38		150306-0-01	F -32							
147895-0-11	Z -16		150800-0-01	J - 6							
147946-0-01	G -37		150801-1-01	J - 7							
147954-0-01	a - 1		150805-0-01	J -12							
147955-0-01	a - 2		150832-0-00	J -11							
147956-0-01	a - 4		151053-0-01	a -10							
147981-0-01	G -33		151181-0-01	K -40							
	Z -31		151185-0-01	K -41							
148285-0-01	C -13		151187-0-01	G -48							
148286-0-01	E -48		151247-0-01	G -47							
148300-0-01	a - 5		151248-0-01	J -12							
148301-0-01	a - 6		180018-0-01	B -41							
148350-0-01	B -38		180022-0-01	B -18							
148449-0-01	D -21		180023-0-01	B -25							
148450-0-01	D -24		180321-0-01	E -54							
148451-0-01	G -12		180322-0-01	E -55							

Customs Excl

54P200



180G054