

brother

DB2-B798

本縫上下送り大釜自動糸切りミシン

SINGLE NEEDLE TOP AND BOTTON FEED LOCK STITCHER WITH LARGE HOOK AND THREAD TRIMMER

EINNADEL-STEPSTICH-SCHNELLNÄHER MIT SCHNELLVERSTELLB. OBER- UND UNTERTRANSPORT, GROSSEM GREIFER UND FADENABSCHNEIDER

PIQUEUSE 1 AIGUILLE - POINT NOUE ENTRAINEMENTS SUPERIEURS ET INFERIEURS AVEC CROCHET GRANDE CAPACITE ET COUPE-FILS

1 AGUJA DOBLE ARRASTRE POR PATA PRENSATELAS, GARFIO GRANDE

PICK LOCATION
03WS08-704



QUANTITY
1
EA

PART: 3573001



PARTS BOOK

BATCH: 11

We're at your side.
brother

S
ENCIA DE PIEZAS

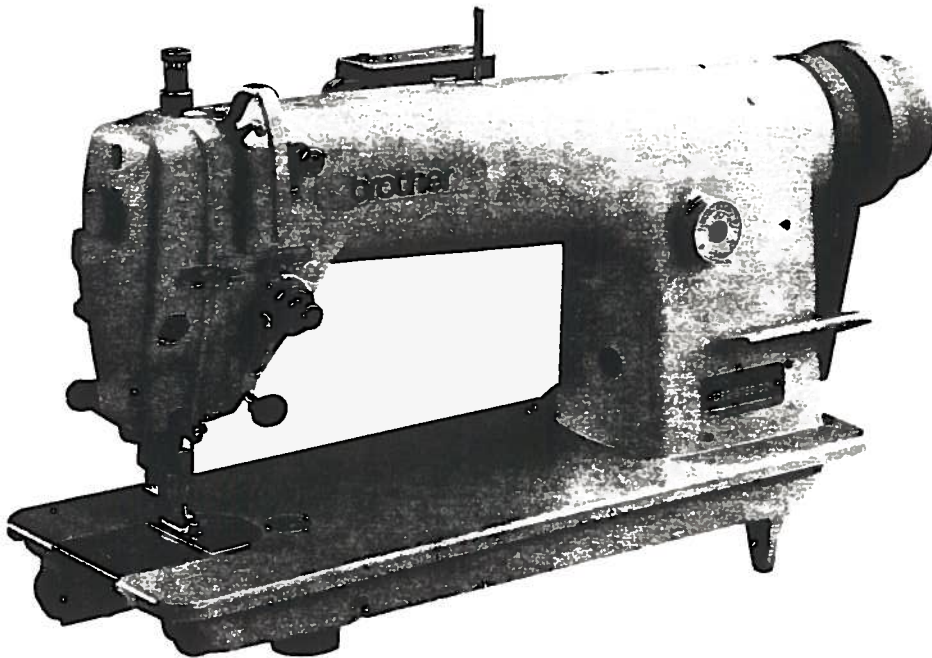

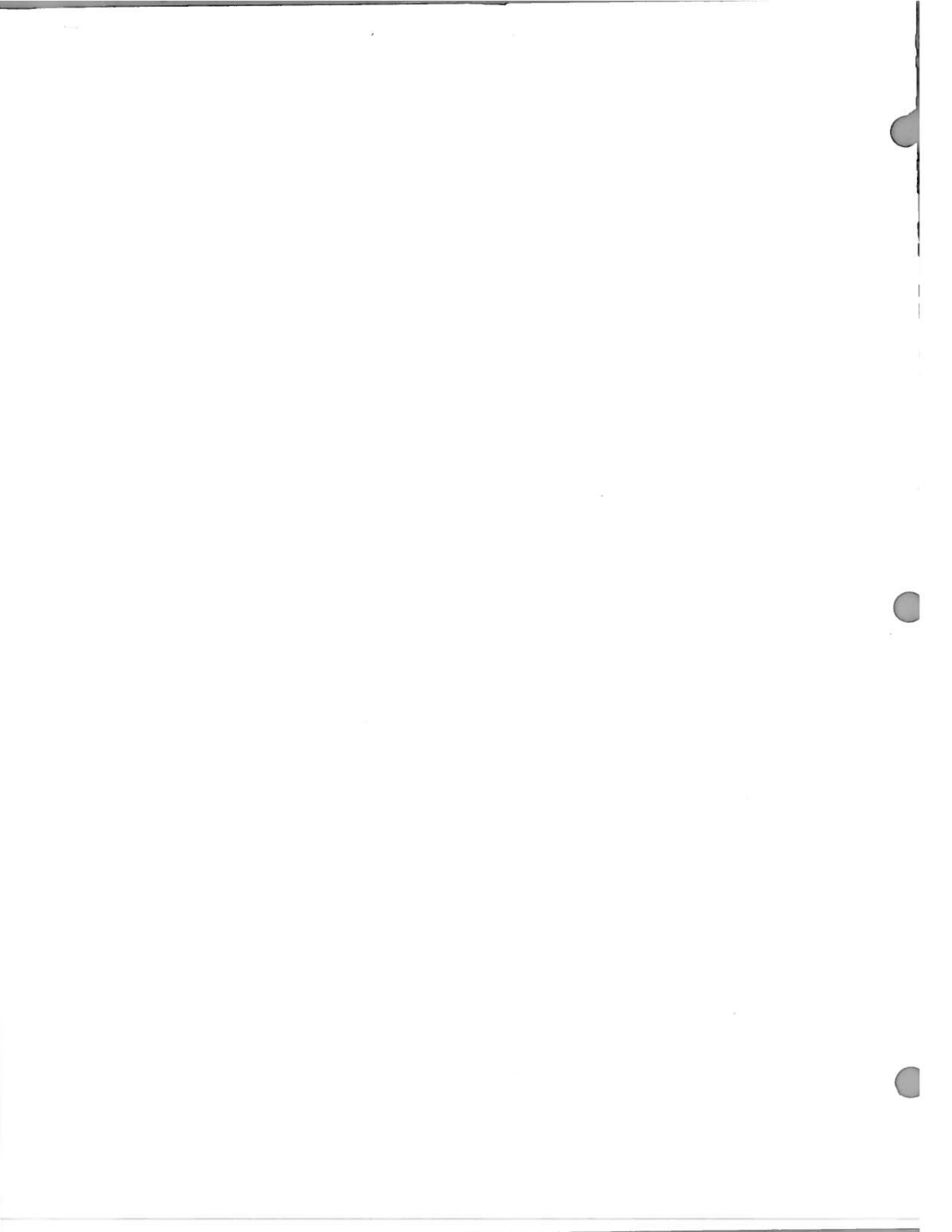

パーツブックご利用に際して

1. 組単位で補給する部品は、 破線で示しております。
2. 部品コード欄が*となっている場合は、仕様別一覧表（32ページ）でお調べ下さい。
3. この本は1993年3月のデータに基づいて作成されたものです。
4. 部品は予告なしに設計変更される場合があります。

目 次

A. 主体関係	2
B. 糸ユルメ関係	2
C. 針棒・天ピン関係	4
D. 押エ関係	6
E. 逆転関係<-300>	6
F. 送り関係	8
G. 上送り関係	12
H. カマ関係	16
J. 給油潤滑関係	18
K. 糸通シ関係	20
L. 糸切り関係	22
M. 逆転スイッチ関係<-300>	26
N. 針位置検出器関係	26
Z 1. 付属品関係	28
Z 2. 付属品関係	30
仕様別一覧表	32
ゲージ部品	33
索引	34

Notes for using this parts book

1. Parts supplied as complete assemblies are circled by a dotted line .
2. If the symbol * is found in the "Parts No." column, refer to the different parts list on page 32.
3. This book was prepared based on information available in March 1993.
4. Parts are subject to changes in design without prior notice.

CONTENTS

A . Machine body	2
B . Tension release mechanism	2
C . Needle bar and thread take-up mechanism	4
D . Presser foot mechanism	6
E . Quick reverse mechanism <-300>	6
F . Feed mechanism	8
G . Upper feed mechanism	12
H . Rotary hook mechanism	16
J . Lubrication	18
K . Threading mechanism	20
L . Thread trimmer mechanism	22
M . Quick reverse switch mechanism <-300>	26
N . Synchronizer	26
Z1 . Accessories	28
Z2 . Accessories	30
DIFFERENT PARTS LIST	32
GAUGE PARTS LIST	33
INDEX	34

Hinweise zur Verwendung dieser Teilleiste

1. Die Teile, die als kompletter Satz geliefert werden, sind mit einer  gestrichelten Linie umrandet.
2. Dieses Zeichen * in der Spalte "Parts No. (Teilnummer)" verweist auf die Gesonderte Stückliste auf Seite 32.
3. Dieses Buch basiert auf den Informationen vom März 1993.
4. Modelländerungen sind vorbehalten.

INHALTSVERZEICHNIS

A. Maschinengehäuse	2
B. Spannungsverminderungsvorrichtung	2
C. Nadelstange und Fadenabnahmevorrichtung	4
D. Stoffdrückerfuß	6
E. Umkehr <-300>	6
F. Transportvorrichtung	8
G. Obertransportvorrichtung	12
H. Greifervorrichtung	16
J. Schmierung	18
K. Fadenführungsvorrichtung	20
L. Fadenabschneidevorrichtung	22
M. Umkehrschalter <-300>	26
N. Synchronisator	26
Z1. Zubehör	28
Z2. Zubehör	30
ZUBEHÖRLISTE	32
LEHRENLISTE	33
VERZEICHNIS	34

Notes sur l'utilisation de ce manuel de pièces détachées



1. Les pièces fournies en tant qu'assemblages complets sont encadrées avec un trait pointillé .
2. Si le symbole * se trouve dans la colonne "Parts No. (N° de pièce)" veuillez la vous référer à la liste de pièces annexe page 32.
3. Ce manuel a été fait d'après les renseignements valables au mois de Mars 1993.
4. Les pièces peuvent être sujettes à des modifications sans préavis.

TABLE DES MATIERES

A. Corps de la machine	2
B. Mécanisme de lâche de tension	2
C. Mécanisme de la barre à aiguille et releveur de fil	4
D. Mécanisme du pied presseur	6
E. Mécanisme de marche arrière rapide <-300>	6
F. Mécanisme de l'entraînement	8
G. Mécanisme de l'entraînement Supérieur	12
H. Mécanisme du crochet rotatif	16
J. Lubrification	18
K. Mécanisme de l'enfilage	20
L. Mécanisme de coupe-fil	22
M. Mécanisme de interrupteur de marche arrière rapide <-300> .	26
N. Synchronisateur	26
Z1. Accessoires	28
Z2. Accessoires	30
LISTE DES PIECES ACCESSOIRES	32
LISTE DES PIECES D'ECARTEMENT	33
INDEX	34

Notas para usar este Manual de Piezas

1. Las piezas suministradas como conjuntos completos se enmarcan con una línea punteada .
2. De haber un símbolo * junto al "Parts No. (Número de Pieza)", habrá que mirar la lista de piezas separadas de la página 32.
3. Este libro ha sido compilado basándose en los datos de que se disponía en marzo 1993.
4. Las piezas quedan sujetas a cambios de diseño sin aviso previo.

INDICE

A. Cuerpo de la máquina	2
B. Mecanismo relajador de tension	2
C. Mecanismo de la barra de aguja y tirahilos	4
D. Mecanismo del prensatelas	6
E. Mecanismo de la inversión rápida <-300>	6
F. Mecanismo de la alimentación	8
G. Mecanismo de la alimentación superior	12
H. Mecanismo del cangrejo	16
J. Lubricación	18
K. Mecanismo del enhebrado	20
L. Mecanismo de la cortadura de hilos	22
M. Mecanismo del conmutador de inversión rápida <-300>	26
N. Sincronizador	26
Z1. Accesorios	28
Z2. Accesorios	30
LISTA DE PIEZAS ACCESORIAS	32
LISTA DE PIEZAS CALIBRADORAS	33
INDICE	34

A. 主体関係/Machine body/Maschinengehäuse/
Corps de la machine/Cuerpo de la máquina

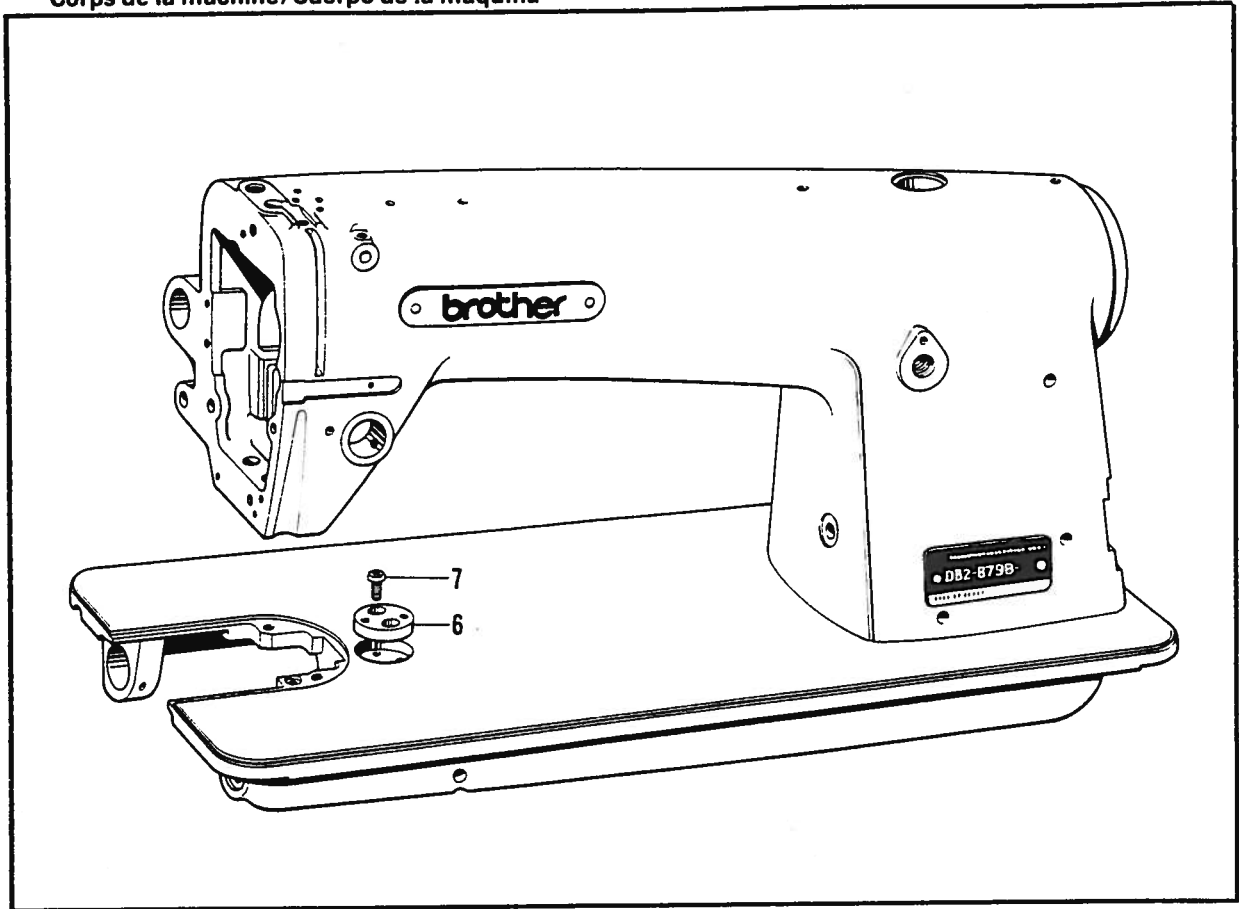

B. 糸ユルメ関係/Tension release mechanism/Spannungsverminderungs-vorrichtung/
Mécánisme de lâche de tension/Mecánismo relajador de tensión

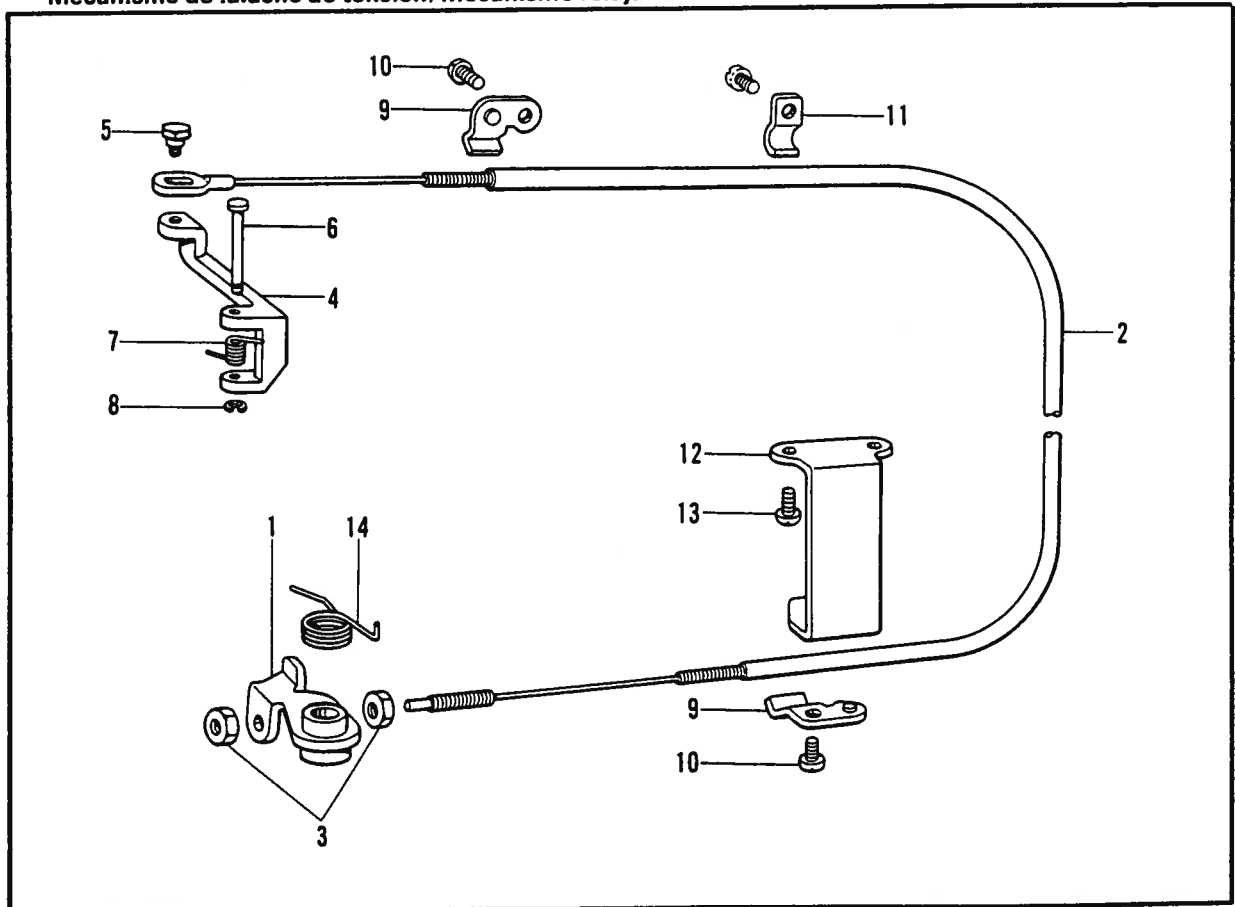

A. 主体関係/Machine body/Maschinengehäuse/
Corps de la machine/Cuerpo de la máquina

REF.NO.	CODE	QTY	ヒンメイ	NAME OF PARTS	RMKS
6	S00888001	1	シヨウキイタ	CLOTH PLATE	
7	062670812	2	ナヘコ357-40X8	SCREW 357X8	

B. 糸ユルメ関係/Tension release mechanism/Spannungsverminderungsvorrichtung/
Mécánisme de lâche de tension/Mecanismo relajador de tension

REF.NO.	CODE	QTY	ヒンメイ	NAME OF PARTS	RMKS
1	S01504001	1	イトユルメレバー	TENSION RELEASE LEVER	
2	S01505009	1	イトユルメワイヤー	TENSION RELEASE WIRE	
3	110161004	2	ナツト4.76	NUT 4.76	
4	S01506001	1	イトユルメイタ	TENSION RELEASE PLATE	
5	159113001	1	ダツネシ3.18	STUD SCREW 3.18	
6	S01507001	1	イトユルメシク	TENSION RELEASE STUD	
7	S01508001	1	イトユルメイタモトシハネ	SPRING	
8	048020342	1	トメフE2	STOP RING E2	
9	149135101	2	イトユルメワイヤーオサエU	TENSION RELEASE WIRE PRESSER (U)	
10	060670612	2	ハインコ357-40X6	SCREW 357X6	
11	140647001	1	コートオサエ	CORD HOLDER	
12	S01509001	1	イトユルメワイヤーホルダD	TENSION RELEASE WIRE HOLDER (D)	
13	062670812	2	ナヘコ357-40X8	SCREW 357X8	
14	S01886101	1	イトユルメモトシハネ	SPRING	

C. 針棒・天ビン関係 / Needle bar and thread take-up mechanism / Nadelstange und Fadenabnahmevorrichtung /
 Mécanisme de la barre à aiguille et releveur de fil / Mecanismo de la barra de aguja y tirahilos

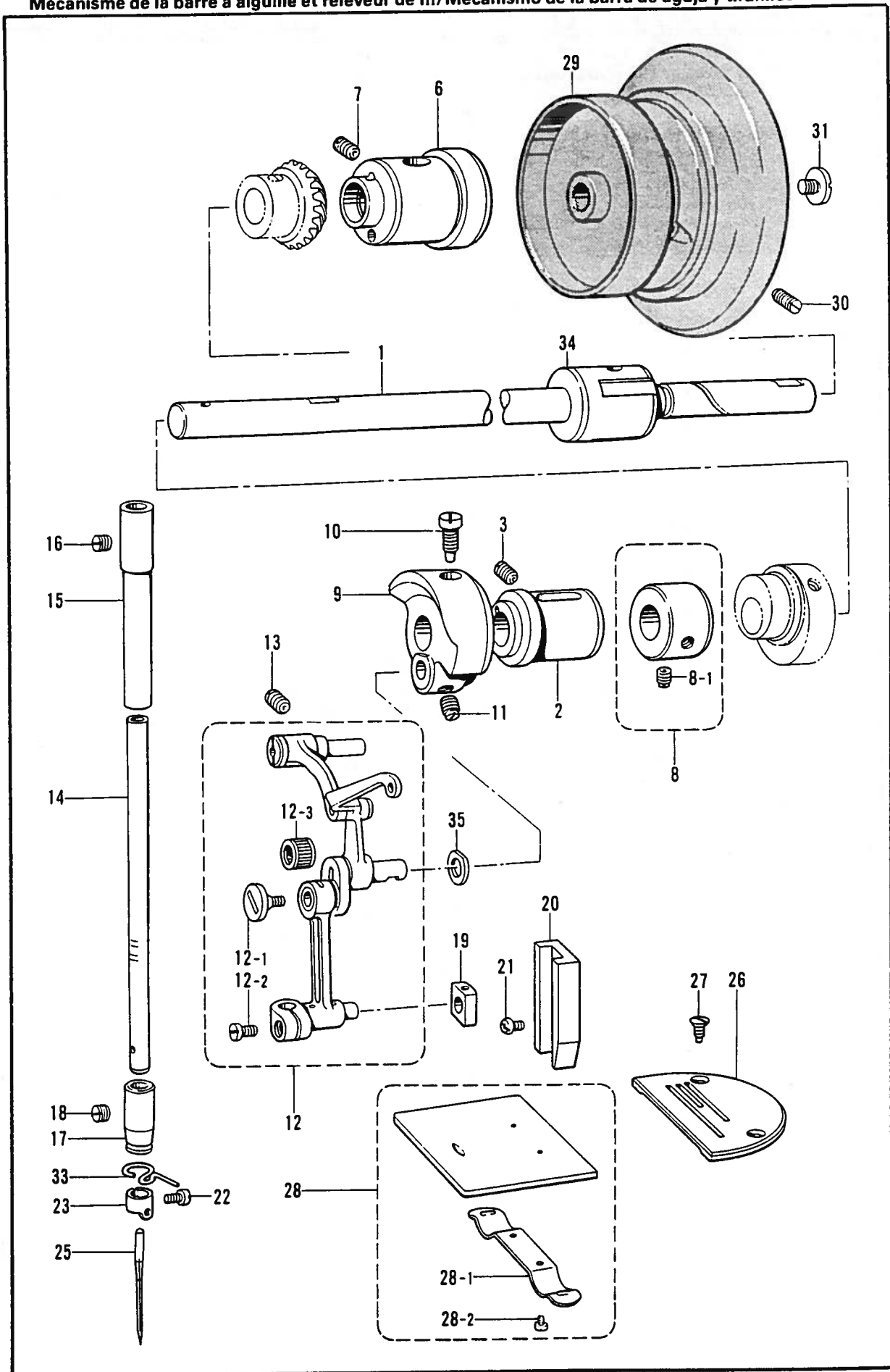

C. 針棒・天ビン関係/Needle bar and thread take-up mechanism/Nadelstange und Fadenabnahmevorrichtung/
 Mécanisme de la barre à aiguille et releveur de fil/Mecanismo de la barra de aguja y tirahilos

REF.NO.	CODE	QTY	ヒンメイ	NAME OF PARTS	RMKS
1	144551001	1	ウワシク	UPPER SHAFT	
2	144552000	1	ウワシクメタルL	UPPER SHAFT BUSH (L)	
3	013761410	1	トメネシ"5.95クホ"ミ	SET SCREW 5.95	
6	148897100	1	ウワシクメタルR	UPPER SHAFT BUSH (R)	
7	013760610	1	トメネシ"5.95クホ"ミ	SET SCREW 5.95	
8	181940001	1	ウワシクセツトカラークミ	UPPER SHAFT SEY COLLAR ASSY	
8-1	151604001	2	トメネシ"5.95	SET SCREW 5.95	
9	S01477000	1	テンピンクラク	COUNTER WEIGHT	
10	104464001	1	シメネシ"7.14	SCREW 7.14	
11	100251001	2	トメネシ"6.35	SET SCREW 6.35	
12	S01478001	1	ハリホウレンカンクミ	THREAD TAKE-UP LEVER ASSY	
12-1	132051001	1	+ サラネシ"3.57L	SCREW 3.57L	
12-2	140004001	1	シメネシ"3.57	SCREW 3.57	
12-3	116735000	1	ニートルヘ"アリンク"	NEEDLE BEARING	
13	013761410	1	トメネシ"5.95クホ"ミ	SET SCREW 5.95	
14	S01481001	1	ハリホウ	NEEDLE BAR	
15	117116001	1	ハリホウメタルU	NEEDLE BAR BUSH (U)	
16	100260001	1	トメネシ"5.95	SET SCREW 5.95	
17	S01482001	1	ハリホウメタルD	NEEDLE BAR BUSH (D)	
18	100260001	1	トメネシ"5.95	SET SCREW 5.95	
19	102630001	1	ハリホウアンナイカクコマ	NEEDLE BAR GUIDE SLIDE BLOCK	
20	S01483001	1	ハリホウアンナイ	NEEDLE BAR GUIDE	
21	062670512	2	ナヘ"コ357-40X5	SCREW 357X5	
22	140553102	1	アタマツキトメネシ"3.18	SET SCREW 3.18	
23	151594001	1	ハリホウイトアンナイ	NEEDLE BAR THREAD GUIDE	
25	145646023	1	ミシンハリDPX17(#23)	NEEDLE DPX17 (#23)	
26	147322001	1	ハリイタC26	NEEDLE PLATE C26	
27	100032004	2	サラネシ"4.37	SCREW 4.37	
28	180018101	1	スヘ"リイタクミ	SLIDE PLATE ASSY	
28-1	114561001	1	スヘ"リイタウラハ"ネ	SPRING	
28-2	122771002	2	シメネシ"2.38	SCREW 2.38	
29	148823009	1	プーリ	PULLEY	
30	S09670001	2	トメクホ"ミ595-28X14	SET SCREW 595X14	
34	116947000	1	ウワシクメタルM	UPPER SHAFT BUSH (M)	
35	110367001	1	サ"カ"ネ	WASHER	

D. 押工関係/Presser foot mechanism/Stoffdrückerfuß/
 Mécanisme du pied presseur/Mecanismo del prensatelas

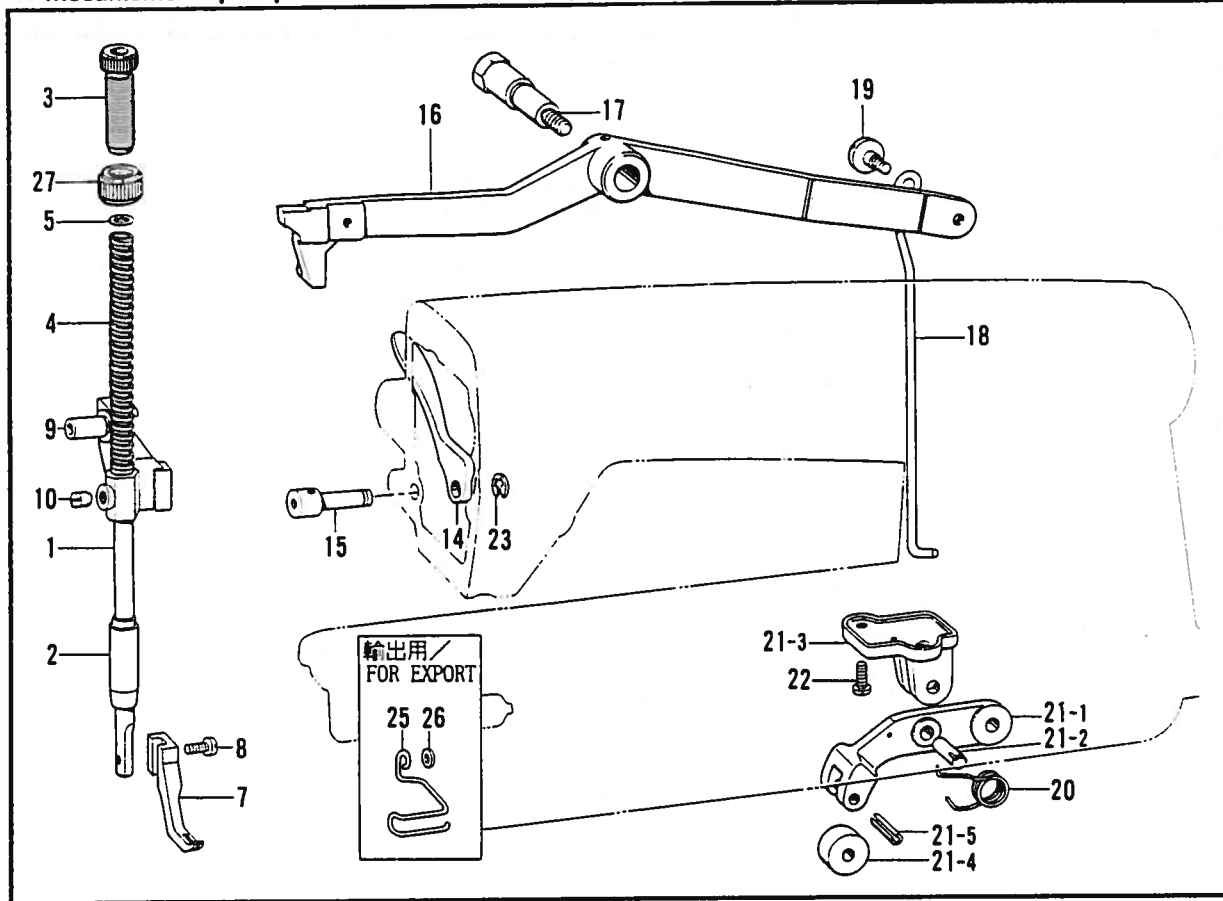

E. 逆転関係/Quick reverse mechanism/Umkehr/
 Mécanisme de marche arrière rapide/Mecanismo de la inversión rápida

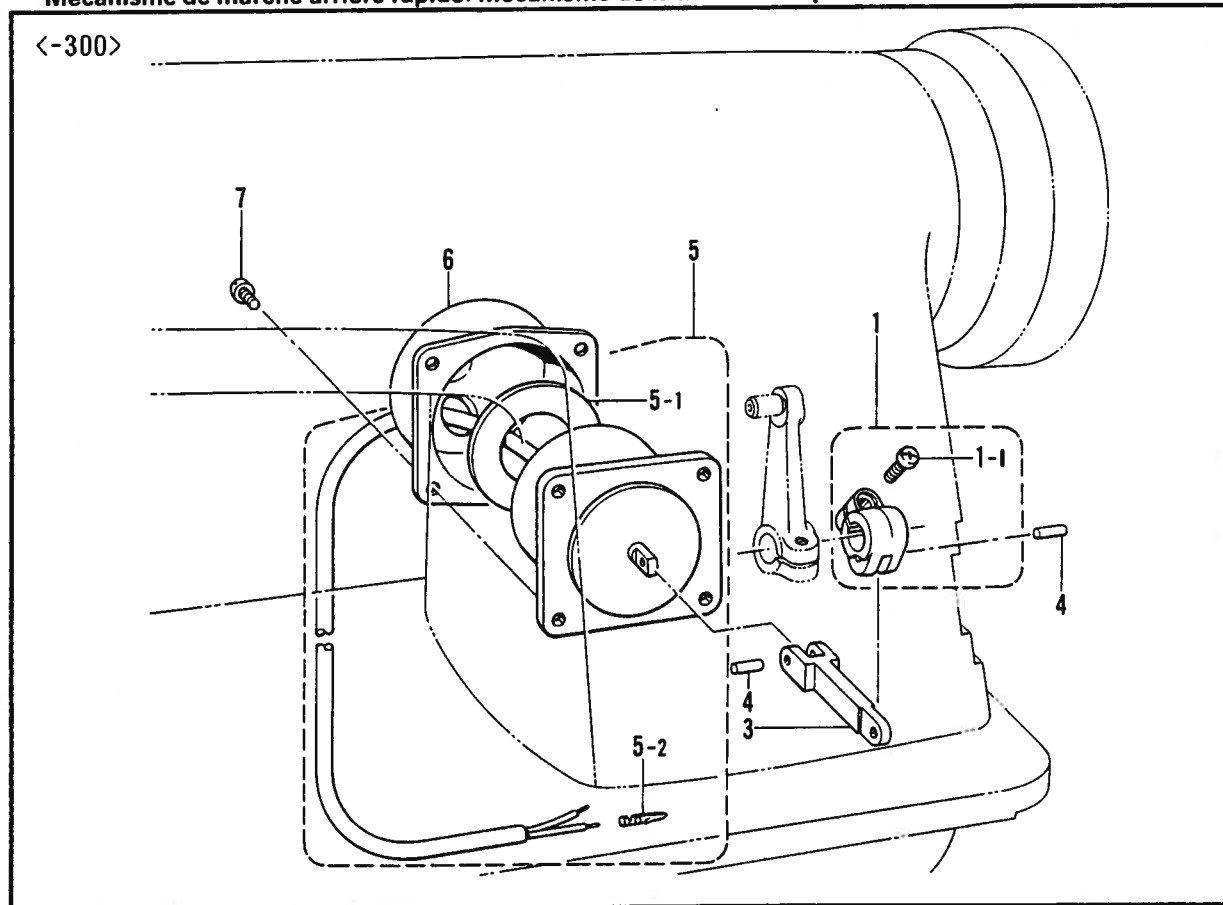

D. 押し関係/Presser foot mechanism/Stoffdrückerfuß/
Mécanisme du pied presseur/Mecanismo del prensatelas

REF.NO.	CODE	QTY	ヒンメイ	NAME OF PARTS	RMKS
1	103013001	1	オサエホ"ウ	PRESSER BAR	
2	150481001	1	オサエホ"ウメタル	PRESSER BAR BUSH	
3	100279109	1	オサエチヨウセツネシ"	PRESSER ADJUSTING SCREW	
4	150482001	1	オサエハ"ネ	PRESSER SPRING	
5	141099001	1	オサエハ"ネサ"カ"ネ	SPRING WASHER	
7	S01484101	1	オサエアシ	PRESSER FOOT	
8	S13385001	1	シメネシ"3.57X10	SCREW 3.57X10	
9	150483001	1	オサエホ"ウタ"キ	PRESSER BAR BRACKET	
10	013760712	1	トメネシ"5.95クホ"ミ	SET SCREW 5.95	
14	142481001	1	オサエアケ"	PRESSER FOOT LIFTER	
15	159991001	1	オサエアケ"シ"ク	PRESSER BAR LIFTER STUD	
16	S01485009	1	ヒサ"アケ"テコ	KNEE LIFTER LEVER	
17	S07976001	1	タ"ンネシ"7.94	STUD SCREW 7.94	
18	150486201	1	ヒサ"アケ"ヒキホ"ウ	KNEE LIFTER CONNECTING ROD	
19	144523001	1	タ"ンネシ"4.76	STUD SCREW 4.76	
20	100304001	1	ツメテコハ"ネ	SPRING	
21	150731101	1	ツメテコクミ	LEVER PAWL	
21-1	S01487001	1	ツメテコ	LEVER PAWL	
21-2	118550001	1	ミソ"ツキヒン	DOWEL PIN	
21-3	144560001	1	ツメテコササエ	KNEE LIFTER CRANK BRACKET	
21-4	S01488001	1	ヒサ"アケ"オシホ"ウローラ	KNEE LIFTING LEVER ROLLER	
21-5	047501842	1	スプリング"ヒン"AW5	SPRING PIN AW-5	
22	062710812	2	ナヘ"コ476-32X8	SCREW 476X8	
23	048060342	1	トメワE6	STOP RING E6	
25	151086000	1	-----	FINGER GUARD	
26	025350132	1	-----	PLAIN WASHER	
27	147846002	1	チヨウセツネシ"ツマミナット	NUT	

E. 逆転関係/Quick reverse mechanism/Umkehr/
Mécanisme de marche arrière rapide/Mecanismo de la inversión rápida

REF.NO.	CODE	QTY	ヒンメイ	NAME OF PARTS	RMKS
<-300>					
1	S01305001	1	ソレノイト"レハ"ークミ	SOLENOID LEVER ASSY	
1-1	062711412	1	ナヘ"コ4.76-32X14	SCREW 476X14	
3	S01493001	1	ソレノイト"ロツト"	SOLENOID ROD	
4	156982001	2	ニート"ルローラ-3X12.8	PIN 3X12.8	
5	*	1	キ"ヤクテンソレノイト"クミ	REVERSE SOLENOID ASSY	
5-1	157981000	1	クツシヨン	CUSHION	
5-2	*	2	ヒン"ターミナルオス	TERMINAL PIN (MALE)	
6	S01496009	1	カハ"ー	COVER	
7	062681012	4	ナヘ"コ437-40X10	SCREW 437X10	

F. 送り関係/Feed mechanism/Transportvorrichtung/
 Mécanisme de l'entraînement/Mecanismo de la alimentación

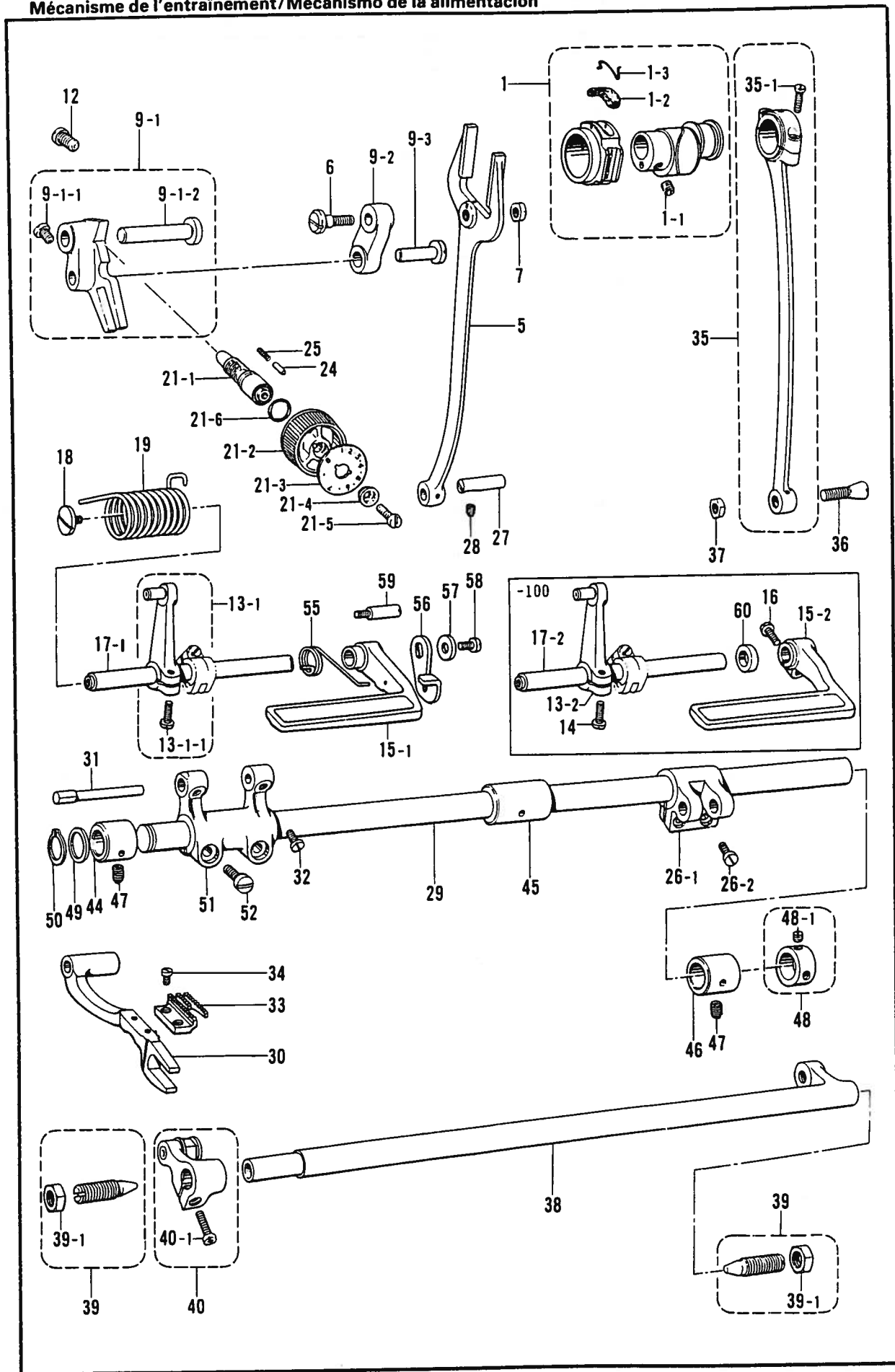

F. 送り関係/Feed mechanism/Transportvorrichtung/
Mécanisme de l'entraînement/Mecanismo de la alimentación

REF.NO.	CODE	Q'TY	品名	NAME OF PARTS	RMKS
1	181647001	1	オクリカムスリーブクミ	FEED CAM SLEEVE ASSY	
1-1	151604001	2	トメネジ ^{5.95}	SET SCREW 5.95	
1-2	106442001	1	フェルト	FELT	
1-3	106440000	1	フェルトオサエ	FELT WIRE	
5	150437001	1	フタマタロツト	FEED FORKED CONNECTOR	
6	149204001	1	タ ^ン ネジ ^{7.14}	STUD SCREW 7.14	
7	104689002	1	ナツト ^{7.14}	NUT 7.14	
9	183366001	1	オクリチヨウセツキオオクミ	FEED REGULATOR ASSY	
9-1	S01599001	1	オクリチヨウセツキクミ	FEED REGULATOR ASSY	
9-1-1	102627001	2	アタマツキトメネジ ^{6.35}	SET SCREW 6.35	
9-1-2	111491001	1	オクリチヨウセツキジ ^ク	FEED REGULATOR STUD	
9-2	S01601001	1	オクリリンク	FEED REGULATOR LINK	
9-3	S01600001	1	オクリリンクジ ^ク	FEED REGULATOR LINK SHAFT	
12	146141001	1	アタマツキトメネジ ^{7.14}	SET SCREW 7.14	
18	100511003	1	シメネジ ^{4.76}	SCREW 4.76	
19	S19652001	1	ネジ ^リ ハ ^ネ	FEED REGULATOR SPRING	
21	183772009	1	オクリメモリイタクミ	STITCH LENGTH CONTROL PLATE ASSY	
21-1	S06999001	1	オクリチヨウセツネジ ^ク	ADJUST SCREW	
21-2	129500010	1	オクリメモリイタタイ	STITCH LENGTH CONTROL DIAL	
21-3	S01598009	1	オクリメモリイタ	STITCH LENGTH CONTROL PLATE	
21-4	142746002	1	メモリイタオサエ	LENGTH CONTROL PLATE SUPPORT	
21-5	129458102	1	シメネジ ^{4.76}	SCREW 4.76	
21-6	108549001	1	Oリング	O RING	
24	145502001	1	メモリイチキ ^メ ヒ ^ン	POSITIONING PIN	
25	100328001	1	メモリイチキ ^メ ヒ ^ン ハ ^ネ	SPRING	
26-1	109152001	1	スイヘイオクリウテ ^ク	FEED ROCK ARM	
26-2	062681212	2	ナ ^ヘ コ ^{3437-40X12}	SCREW 437X12	
27	109153001	1	ピン	PIN	
28	151602002	1	トメネジ ^{4.37}	SET SCREW 4.37	
29	150439101	1	スイヘイオクリジ ^ク	FEED ROCK SHAFT	
30	147767001	1	オクリタ ^イ	FEED BAR	
31	S01586001	1	オクリタ ^イ ジ ^ク	FEED BAR SHAFT	
32	104908001	2	アタマツキトメネジ ^{4.37}	SET SCREW 4.37	
33	S01489001	1	オクリハ ^ク	FEED DOG	
34	100080003	2	シメネジ ^{3.18}	SCREW 3.18	
35	118293001	1	クランクロツト ^ク ミ	CRANK ROD ASSY	
35-1	144712001	2	シメネジ ^{4.76}	SCREW 4.76	
36	100310001	1	テーパ ^ネ ジ ^{7.14}	TAPER SCREW	
37	104689002	1	ナツト ^{7.14}	NUT 7.14	
38	116995001	1	ジ ^{ョウ} ケ ^ク オクリジ ^ク	FEED LIFTING ROCK SHAFT	
39	180987001	2	ネジ ^{セン} タク ^ミ	CENTER POINT SCREW ASSY	
39-1	100075004	2	ナツト ^{9.52}	NUT 9.52	
40	181941101	1	UDオクリウテ ^ク ミ	FEED LIFTING ARM ASSY	
40-1	062681612	1	ナ ^ヘ コ ^{3437-40X16}	SCREW 437X16	
44	150440000	1	スイヘイオクリジ ^ク メタルL	FEED ROCK SHAFT BUSH (L)	
45	150488000	1	スイヘイオクリジ ^ク メタルM	FEED ROCK SHAFT BUSH (M)	
46	150441000	1	スイヘイオクリジ ^ク メタルR	FEED ROCK SHAFT BUSH (R)	
47	151604002	2	トメネジ ^{5.95}	SET SCREW 5.95	
48	183493001	1	オクリジ ^ク セツトカラ ^ク ミ	FEED SHAFT SET COLLAR ASSY	
48-1	101706001	2	トメネジ ^{6.35}	SET SCREW 6.35	
49	116920001	1	オクリジ ^ク スラストリング ^ク	THRUST RING	
50	048150142	1	トメワジ ^ク ヨウ ^{C15}	STOP RING C15	
51	S01491001	1	スイヘイオクリタ ^イ ウテ ^ク	HORIZONTAL FEED BAR ARM	
52	S01304001	2	シメネジ ^{6.35X18}	SCREW 6.35X18	
<-300>					
13-1	183238001	1	オクリチヨウセツレハ ^ク ミ	FEED REGULATOR LEVER ASSY	
13-1-1	062711412	1	ナ ^ヘ コ ^{4.76-32X14}	SCREW 476X14	
15-1	156362009	1	カエシヌイレハ ^ク	REVERSE STITCHING LEVER	
17-1	S01490001	1	カエシヌイレハ ^ク ジ ^ク	REVERSE STITCHING LEVER SHAFT	
55	148608101	1	カエシヌイレハ ^ク オサエハ ^ネ	SPRING	
56	149091001	1	カエシヌイレハ ^ク イタ	REVERSE STITCHING LEVER PLATE	
57	116662003	1	ワ ^シ カ ^ネ	WASHER	

F. 送り関係/Feed mechanism/Transportvorrichtung/
 Mécanisme de l'entraînement/Mecanismo de la alimentación

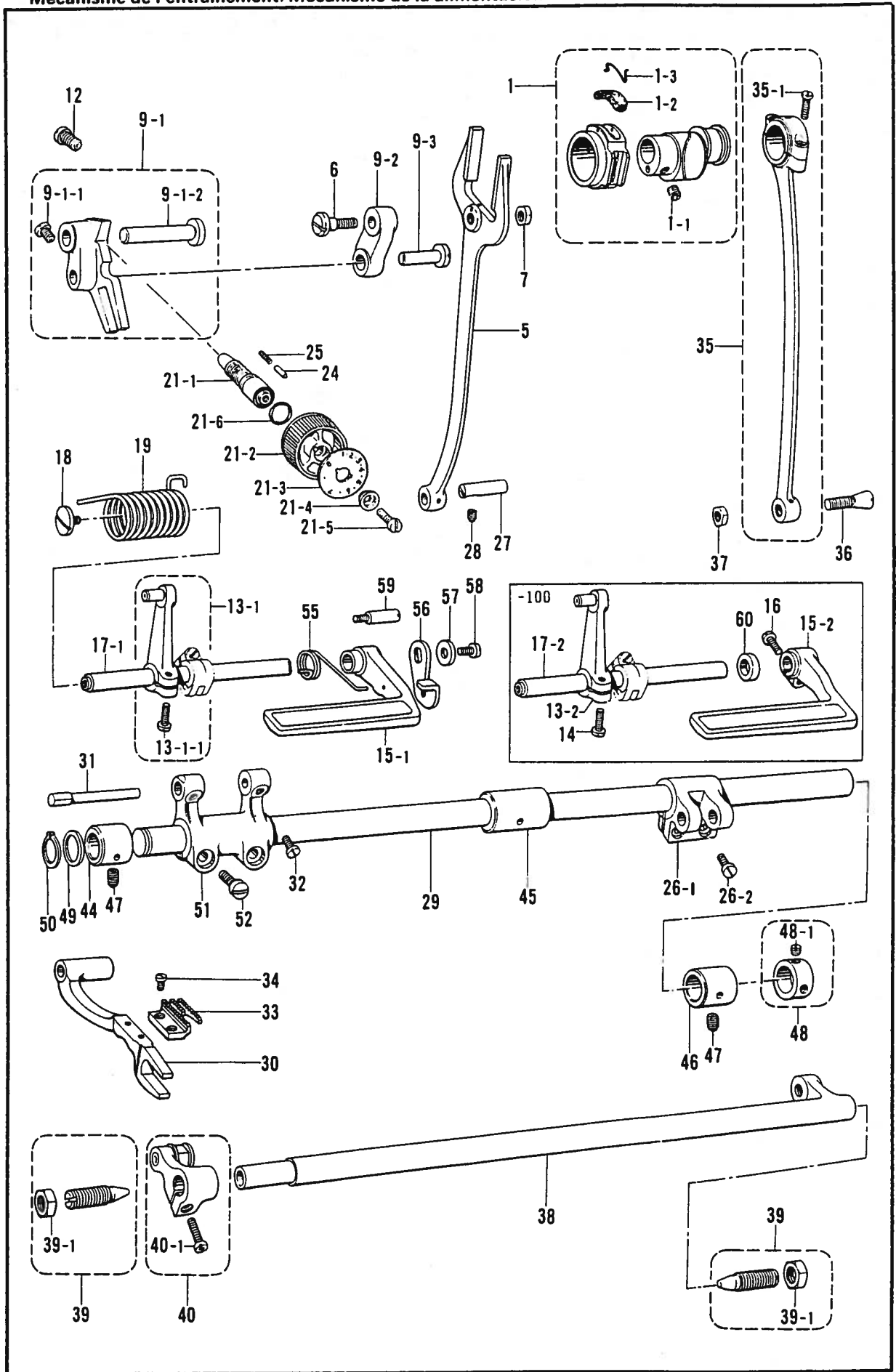

F. 送り関係/Feed mechanism/Transportvorrichtung/
 Mécanisme de l'entraînement/Mecanismo de la alimentación

REF NO.	CODE	Q'TY	品名	NAME OF PARTS	RMKS
58	062710812	1	ナヘ"コ476-32X8	SCREW 476X8	
59	141748001	1	カムフタシメネジ"	SCREW	
< -100 >					
13-2	116953001	1	-----	FEED REGULATOR LEVER ASSY	
14	108749001	1	-----	BOLT 5.95	
15-2	147503009	1	-----	REVERSE STITCHING LEVER	
16	062711412	1	-----	SCREW 476X14	
17-2	108541001	1	-----	REVERSE STITCHING LEVER SHAFT	
60	S01476001	1	-----	COLLAR	

G. 上送り関係/Upper feed mechanism/Obertransportvorrichtung/
 Mécanisme de l'entraînement Supérieur/Mecanismo de la alimentación superior

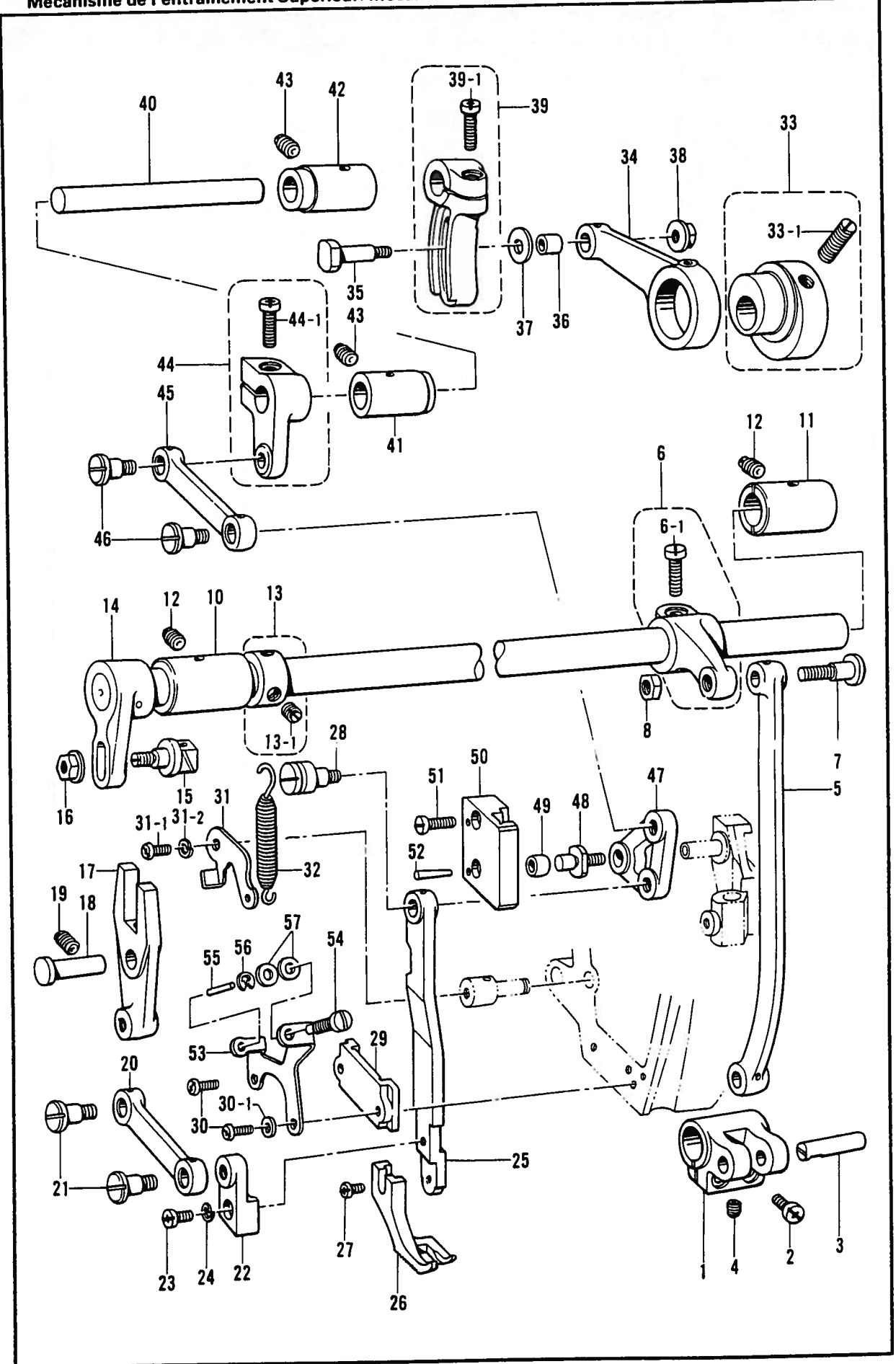

G. 上送り関係 / Upper feed mechanism / Obertransportjorrichtung /
 Mécanisme de l'entraînement Supérieur / Mecanismo de la alimentación superior

REF.NO.	CODE	QTY	ヒンメイ	NAME OF PARTS	RMKS
1	109152001	1	スイハイオクリウテ	FEED ROCK ARM	
2	062681212	2	ナヘコ437-40X12	SCREW 437X12	
3	109153001	1	ピン	PIN	
4	151602002	1	トメネジ4.37	SET SCREW 4.37	
5	150442001	1	UスイハイオクリレンカンL	UPPER FEED ROCK CONNECTOR (L)	
6	150501001	1	UスイハイオクリウテRクミ	UPPER FEED ROCK ARM (R) ASSY	
6-1	S01304001	1	シメネジ6.35X18	SCREW 6.35X18	
7	149204001	1	ダンネジ7.14	STUD SCREW 7.14	
8	104689002	1	ナツト7.14	NUT 7.14	
10	150444000	1	UスイハイオクリシクメタルL	UPPER FEED ROCK SHAFT BUSH (L)	
11	150445000	1	UスイハイオクリシクメタルR	UPPER FEED ROCK SHAFT BUSH (R)	
12	151604002	2	トメネジ5.95	SET SCREW 5.95	
13	183493001	1	オクリシクセットカラークミ	FEED SHAFT SET COLLAR ASSY	
13-1	101706001	2	トメネジ6.35	SET SCREW 6.35	
14	150446001	1	Uスイハイオクリシククミ	UPPER FEED ROCK SHAFT ASSY	
15	150502101	1	コロシククミ	ROLLER STUD ASSY	
16	110778002	1	サツキナツト5.56	NUT 5.56	
17	153514001	1	Uスイハイオクリレハ-	UPPER FEED ROCK LEVER	
18	150491001	1	レハ-シク	UPPER FEED SHAFT	
19	151604002	1	トメネジ5.95	SET SCREW 5.95	
20	150450001	1	リンクS	LINK (S)	
21	150451001	2	ダンネジ6.35	STUD SCREW 6.35	
22	150452001	1	オクリアシレンカンタキ	FEEDING FOOT CONNECTOR BRACKET	
23	062680812	1	ナヘコ437-40X8	SCREW 437X8	
24	028680242	1	ハネサカネ2-4.37	SPRING WASHER 2-4.37	
25	153512001	1	オクリアシレンカン	FEEDING FOOT CONNECTOR	
26	150454101	1	オクリアシ	FEEDING FOOT	
27	060670812	1	ハイント357-40X8	SCREW 357X8	
28	150430001	1	ダンネジ6.35	STUD SCREW 6.35	
29	153513001	1	オクリアシレンカンアンナイ	FEEDING FOOT CONNECTOR GUIDE	
30	062671412	2	ナヘコ357-40X14	SCREW 357X14	
30-1	105161003	1	サガネ	WASHER	
31	159993001	1	ハネカケ	SPRING HOLDER	
31-1	062681012	1	ナヘコ437-40X10	SCREW 437X10	
31-2	028680242	1	ハネサカネ2-4.37	SPRING WASHER 2-4.37	
32	159992001	1	オクリアシオサエハネ	FEEDING FOOT PRESSER SPRING	
33	150503101	1	U-UDオクリヘンシンリンクミ	U-UD FEED LIFTING ECCENTRIC WHEEL ASSY	
33-1	013761410	2	トメネジ5.95クホミ	SET SCREW 5.95	
34	150465001	1	U-UDオクリレンカン	U-UD LIFTING FEED CONNECTING ROD	
35	150460001	1	U-UDオクリレハ-シク	U-UD FEED LIFTING LEVER SHAFT	
36	150461001	1	オクリコロ	FEED ROLLER	
37	107453001	1	サガネ	WASHER	
38	110778002	1	サツキナツト5.56	NUT 5.56	
39	150504001	1	U-UDオクリウテRクミ	U-UD FEED LIFTING ROCK ARM (R) ASSY	
39-1	062751612	1	ナヘコ556-32X16	SCREW 556X16	
40	150463001	1	U-UDオクリシク	U-UD FEED SHAFT	
41	S02322001	1	カムシクメタルL	CAM SHAFT BUSH (L)	
42	S02321001	1	カムシクメタルR	CAM SHAFT BUSH (R)	
43	151604002	2	トメネジ5.95	SET SCREW 5.95	
44	150505001	1	U-UDオクリウテLクミ	U-UD FEED LIFTING ROCK ARM (L) ASSY	
44-1	062751612	1	ナヘコ556-32X16	SCREW 556X16	
45	150459001	1	リンクL	LINK (L)	
46	150451001	2	ダンネジ6.35	STUD SCREW 6.35	
47	150466001	1	U-UDオクリレハ-	U-UD FEED LIFTING LEVER	
48	150467001	1	コロシク	ROLLER SHAFT	
49	150468001	1	U-UDオクリレハ-コロ	U-UD FEED LIFTING LEVER ROLLER	
50	150469001	1	U-UDオクリレハ-アンナイ	U-UD FEED LIFTING LEVER GUIDE	
51	062671412	2	ナヘコ357-40X14	SCREW 357X14	
52	046301620	2	テーパピン3X16	TAPER PIN 3X16	
53	159996001	1	チヨウセツネジホルダ	PRESSER ADJUSTING SCREW HOLDER	
54	159994001	1	チヨウセツネジ	PRESSER ADJUSTING SCREW	
55	159995001	1	チヨウセツピン	PRESSER ADJUSTING PIN	

G. 上送り関係/Upper feed mechanism/Obertransportjorrichtung/
 Mécanisme de l'entraînement Supérieur/Mecanismo de la alimentación superior

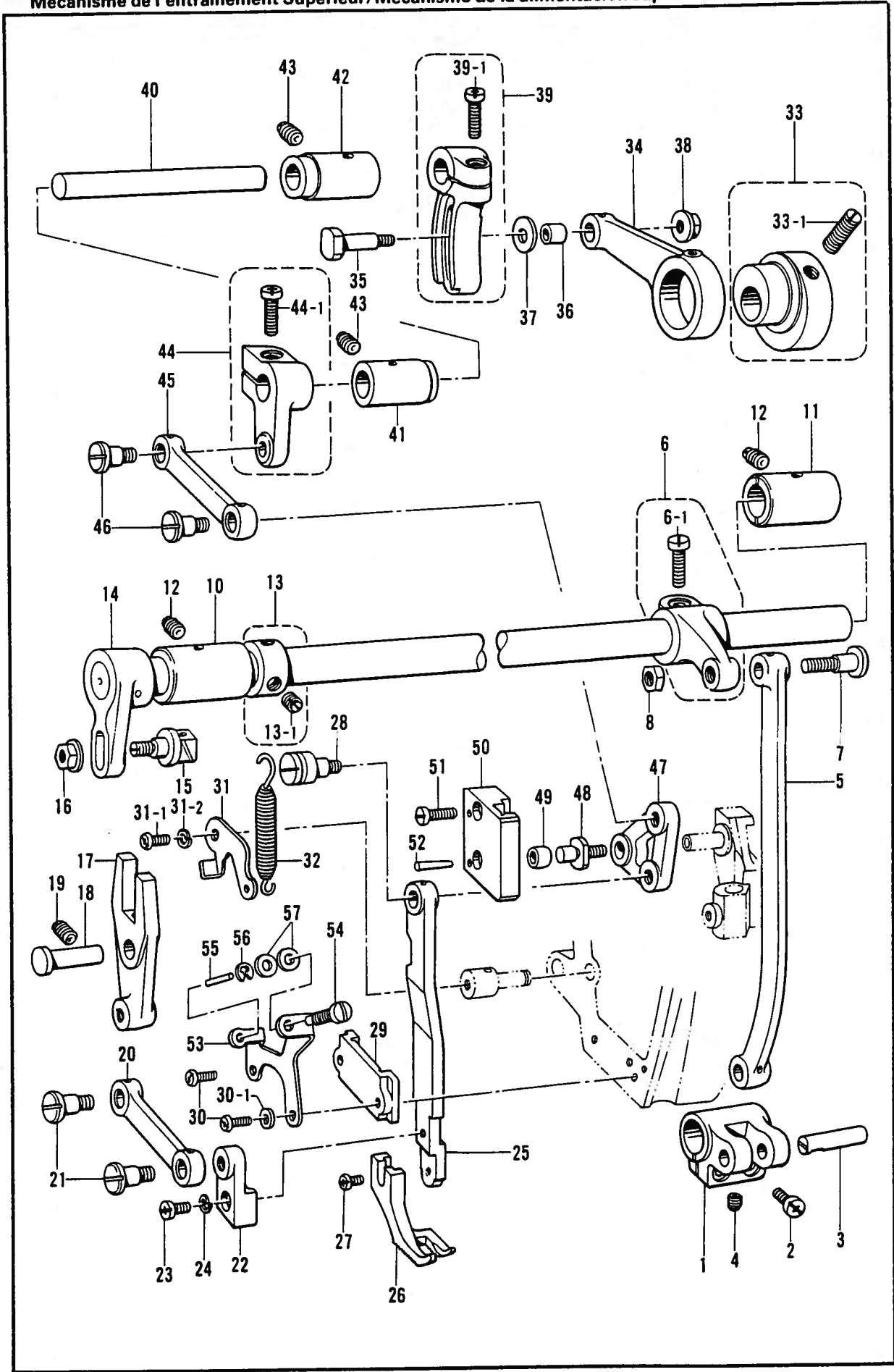

G. 上送り関係/Upper feed mechanism/Obertransportjorrichtung/
 Mécanisme de l'entraînement Supérieur/Mecanismo de la alimentación superior

REF.NO.	CODE	Q'TY	ヒンメイ	NAME OF PARTS	RMKS
56	048040342	1	トメツE4	STOP RING E4	
57	109893002	2	サカガネ	WASHER	

H. カマ関係/Rotary hook mechanism/Greifervorrichtung/
 Mécanisme du crochet rotatif/Mecanismo del cangrejo

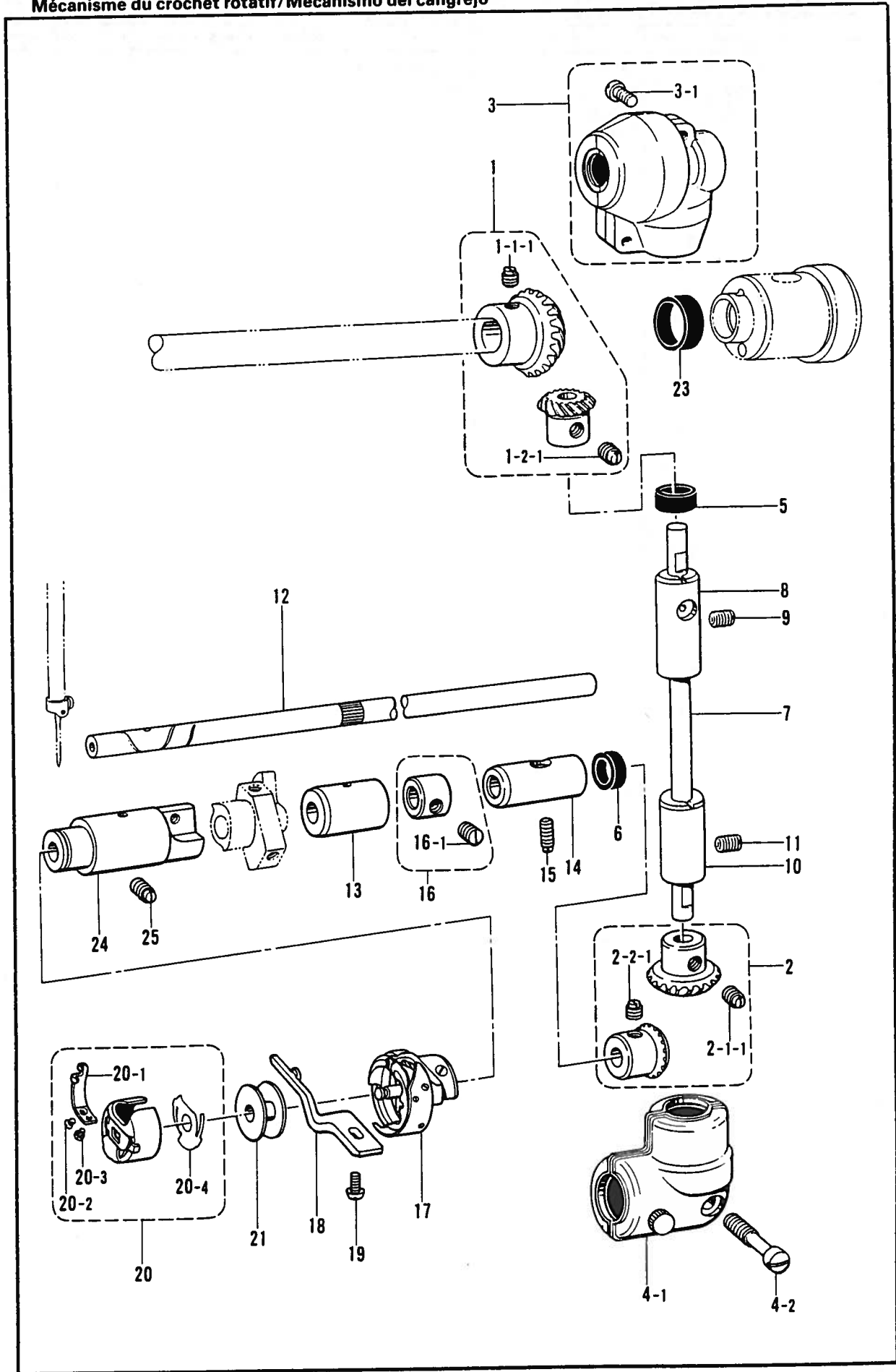

H. カマ関係/Rotary hook mechanism/Greifervorrichtung/
Mécanisme du crochet rotatif/Mecanismo del cangrejo

REF.NO.	CODE	Q'TY	ヒンメイ	NAME OF PARTS	RMKS
1	140378001	1	ヘ"ヘルキ"ヤUクミ	BEVEL GEAR (U) ASSY	
1-1-1	100251001	2	トメネシ"6.35	SET SCREW 6.35	
1-2-2	100251001	2	トメネシ"6.35	SET SCREW 6.35	
2	150435001	1	シタシ"クヘ"ヘルキ"ヤクミ	LOWER SHAFT GEAR ASSY	
2-1-1	100251001	2	トメネシ"6.35	SET SCREW 6.35	
2-2-2	100251001	2	トメネシ"6.35	SET SCREW 6.35	
3	140384001	1	ヘ"ヘルキ"ヤケースUクミ	BEVEL GEAR CASE (U) ASSY	
3-1	100320002	2	シメネシ"4.76	SCREW 4.76	
4	118298001	1	シタヘ"ヘルキ"ヤケースクミ	LOWER GEAR CASE	
4-1	110320000	1	ヘ"ヘルキ"ヤケースD	BEVEL GEAR (D)	
4-2	100343001	1	シメネシ"7.14	SET SCREW	
5	103796001	2	シール	SEAL	
6	103797001	1	シール	OIL SEAL	
7	150470001	1	タテシ"ク	VERTICAL SHAFT	
8	148913000	1	タテシ"クメタルU	VERTICAL SHAFT BUSH (U)	
9	013760610	1	トメネシ"5.95クホ"ミ	SET SCREW 5.95	
10	148914000	1	タテシ"クメタルD	VERTICAL SHAFT BUSH (D)	
11	013761410	1	トメネシ"5.95クホ"ミ	SET SCREW 5.95	
12	S01497001	1	シタシ"ク	LOWER SHAFT	
13	118762000	1	シタシ"クメタルM	LOWER SHAFT BUSH (M)	
14	150473000	1	シタシ"クメタルR	LOWER SHAFT BUSH (R)	
15	151607001	1	トメネシ"4.37	SET SCREW 4.37	
16	181995001	1	セツトカラークミ	SET COLLAR ASSEMBLY	
16-1	101706001	2	トメネシ"6.35	SET SCREW 6.35	
17	159793001	1	コウソクカマB1	ROTARY HOOK B1	
18	147337001	1	ウチカマトメ	BOBBIN CASE HOLDER POSITION BRACKET	
19	062681212	1	ナヘ"コ437-40X12	SCREW 437X12	
20	151845001	1	ホ"ビ"ンケースクミ	BOBBIN CASE ASSY	
20-1	181936001	1	ホ"ビ"ンケースチヨウシハ"ネ	TENSION SPRING	
20-2	181937001	1	チヨウシハ"ネチヨウセツネシ"	ADJUST SCREW	
20-3	181938001	1	チヨウシハ"ネトメネシ"	SET SCREW	
20-4	151844001	1	クウチンホ"ウシハ"ネ	BOBBIN TENSION SPRING	
21	S01587001	1	ホ"ビ"ン	BOBBIN	
23	103738001	1	シール	SEAL	
24	S01498000	1	シタシ"クメタルL	LOWER SHAFT BUSH (L)	
25	151603002	1	トメネシ"4.37	SET SCREW 4.37	

J. 給油潤滑関係/Lubrication/Schmierung/
Lubrification/Lubricación

REF.NO.	CODE	QTY	品名	NAME OF PARTS	RMKS
1	140560001	1	フェルト	FELT	
2	148918000	2	フェルト8.5	FELT 8.5	
3	141744009	1	オイルフタ	OIL CAP	
5	150474009	1	カ"フイタ	REAR PLATE	
6	062670612	2	ナヘ"357-40X6	SCREW 357X6	
7	062670812	1	ナヘ"357-40X8	SCREW 357X8	
9	150475000	1	ビ"ニルチューブ"	VINYL TUBE	
10	150476000	1	クミヒモ6X6	WICK 6X6	
11	148806001	1	チューブ"ササエ	TUBE HOLDER	
12	062670612	1	ナヘ"357-40X6	SCREW 357X6	
13	150477001	1	スイアケ"オイルヒモササエ	WICK SUPPORTER	
14	062670612	1	ナヘ"357-40X6	SCREW 357X6	
15	S27846009	1	-----	OIL PAN ASSY	
16	109714000	4	-----	NAIL	
17	114486002	1	-----	OILER	
18	115812002	1	フェルト	FELT	
19	114255001	1	キャツプ	CAP	
20	104451009	1	メクラセン	OIL CAP	
21	104547001	1	ユリヨウケイマト"	OIL GAUGE WINDOW	
22	151074009	1	ユリヨウケイフタ	OIL GAUGE COVER	
23	081014670	1	O"リング"PW14	O RING PW14	
24	100257010	4	シメネジ"3.57	SCREW 3.57	
25	118768001	1	クミヒモ(L=150)	WICK (L=150)	
26	S01502000	1	キユウユパイプ	OIL PIPE	
27	100248001	1	フェルト	FELT	
28	108805001	2	クミヒモ6X6	WICK	
29	150815009	1	メンイタキャツプ	FACE PLATE CAP	
30	111865009	1	オイルメクラセン	OIL CAP	
31	112735000	1	クミヒモ(L=45)	WICK (L=45)	
32	S14030000	1	フェルト	FELT	
33	S01503001	1	オイルチヨウセツネジ"	OIL ADJUSTING SCREW	
34	145621001	1	ソレノイト"オシハ"ネ	SPRING	
<-100>					
35	S01585009	1	-----	REAR PLATE (D)	
36	062680712	4	-----	SCREW 437X7	

K. 糸通シ関係/Threading mechanism/Fadenführungsrichtung/
 Mécanisme de l'enfilage/Mecanismo del enhebrado

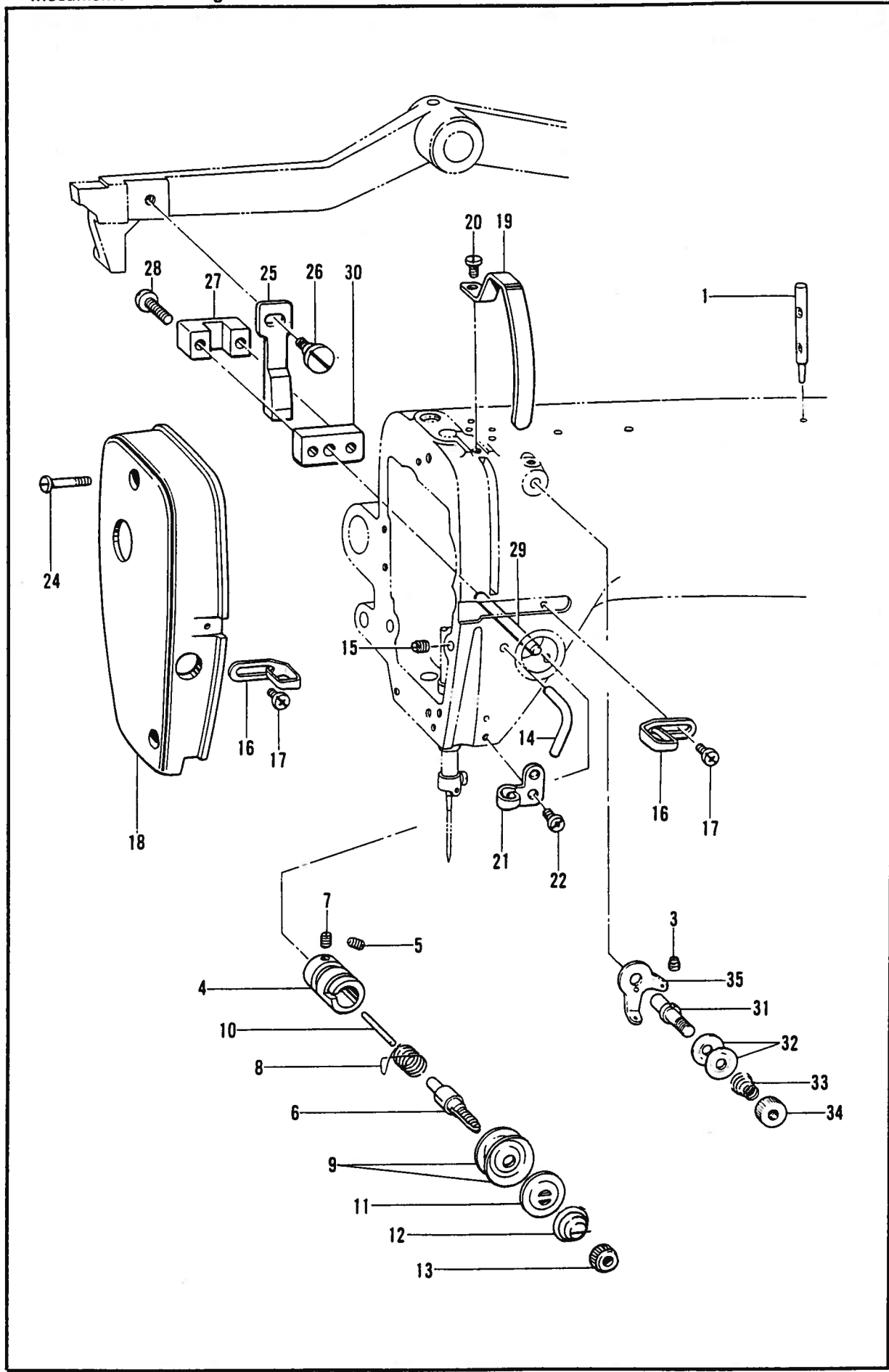

K. 糸通シ関係/Threading mechanism/FadenführungsVorrichtung/
 Mécanisme de l'enfilage/Mecanismo del enhebrado

REF.NO.	CODE	QTY	ヒンメイ	NAME OF PARTS	RMKS
1	147557101	1	イトタテホウ	SPOOL PIN	
3	151602002	1	トメネシ"4.37	SET SCREW 4.37	
4	145250001	1	イトチヨウシホ"ウタイ	THREAD TENSION BRACKET	
5	103950003	1	トメネシ"5.95	SET SCREW 5.95	
6	100398001	1	イトチヨウシホ"ウ	TENSION STUD	
7	100402004	1	トメネシ"3.57	SET SCREW 3.57	
8	148923001	1	イトトリハ"ネ	SPRING	
9	145446001	2	イトチヨウシサラ	TENSION DISC	
10	S01499000	1	イトユルメピン	TENSION RELEASE PIN	
11	159805001	1	イトチヨウシサラオサイ	TENSION DISC PRESSER	
12	148924101	1	イトチヨウシハ"ネ	TENSION SPRING	
13	100136001	1	イトチヨウシナツト	TENSION NUT	
14	116112001	1	イトアンナイ	THREAD GUIDE	
15	151602002	1	トメネシ"4.37	SET SCREW 4.37	
16	147339001	2	アームイトアンナイ	ARM THREAD GUIDE	
17	060670612	2	ハ"イント"357-40X6	SCREW 357X6	
18	159997009	1	メンイタ	FACE PLATE	
19	147338009	1	テンビ"ンカハ"ー	THREAD TAKE-UP COVER	
20	062680712	1	ナハ"コ437-40X7	SCREW 437X7	
21	S01501001	1	イトカケ	THREAD RETAINER	
22	062670412	1	ナハ"コ357-40X4	SCREW 357X4	
24	118475002	2	シメネシ"3.57	SCREW 3.57	
25	150479001	1	イトユルメ	TENSION RELEASER	
26	113730001	1	ダ"ンネシ"4.37	STUD SCREW 4.37	
27	150480001	1	イトユルメアンナイ	TENSION RELEASER GUIDE	
28	062671412	2	ナハ"コ357-40X14	SCREW 357X14	
29	S01500001	1	イトユルメアンナイシ"ク	THREAD RELEASE GUIDE SHAFT	
30	S01588001	1	イトユルメアンナイダ"イ	TENSION RELEASE GUIDE BRACKET	
31	154559001	1	イトアンナイチヨウシホ"ウ	THREAD GUIDE CONTROL SHAFT	
32	144504001	2	イトアンナイサラ	THREAD GUIDE DISC	
33	154562001	1	プレテンションハ"ネB	PRE TENSION SPRING (B)	
34	155510001	1	イトチヨウシナツト	TENSION NUT	
35	154563001	1	イトアンナイ	THREAD GUIDE	

L. 糸切り関係/Thread trimmer mechanism/Fadenabschneidevorrichtung/
 Mécanisme de coupe-fil/Mecanismo de la cortadura de hilos

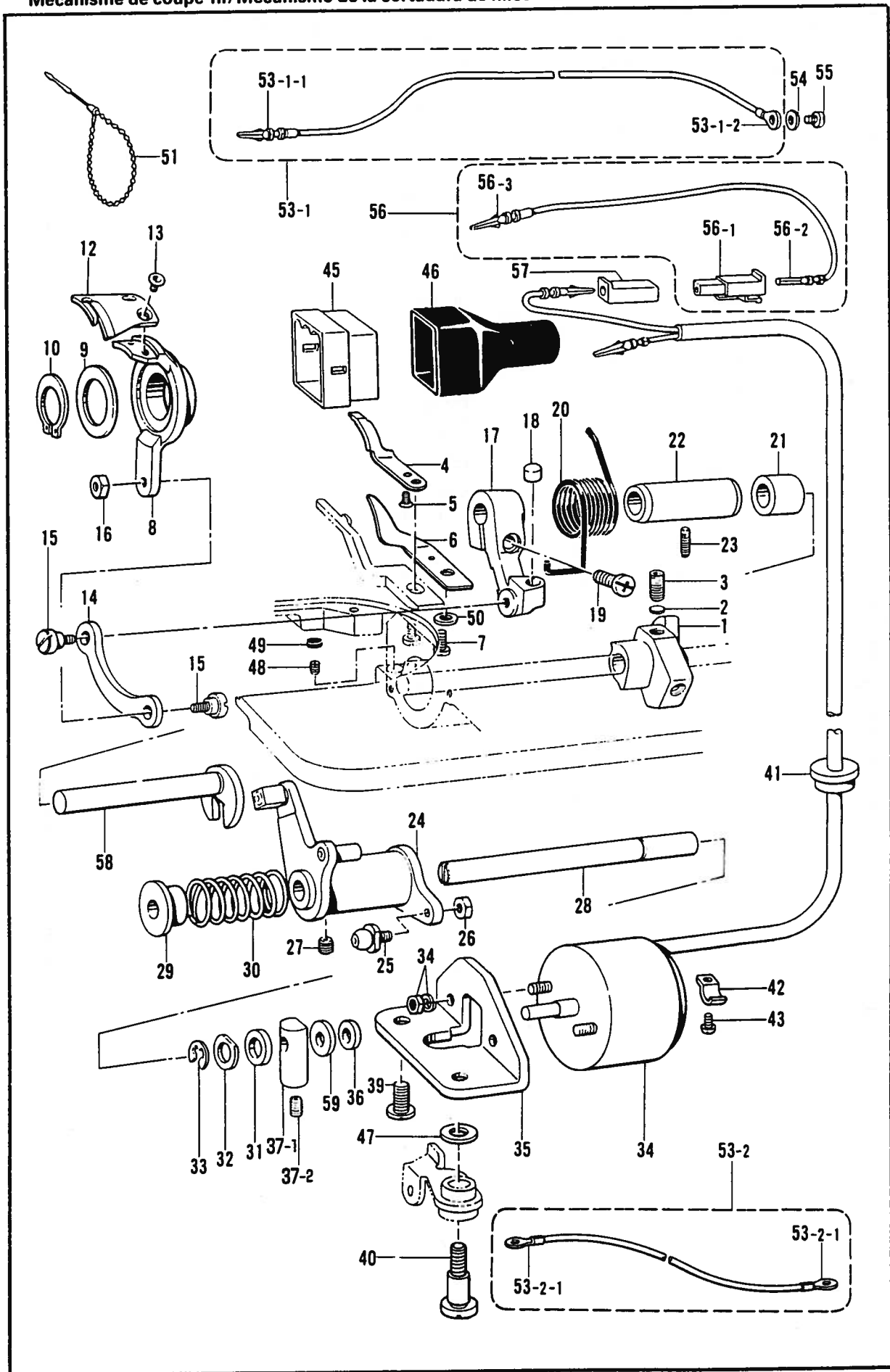

L. 糸切り関係/Thread trimmer mechanism/Fadenabschneidevorrichtung/
Mécánisme de coupe-fil/Mecanismo de la cortadura de hilos

REF.NO.	CODE	QTY	ヒンメイ	NAME OF PARTS	RMKS
1	S00337001	1	イトキリカム	THREAD TRIMMER CAM	
2	154567000	2	カンサ ^{5.3}	WASHER 5.3	
3	014771022	2	アナトメネシ ^{6.35} クホ ^ミ	SET SCREW 6.35	
4	154568101	1	コテイハ	FIXED KNIFE	
5	102843004	1	サラネシ ^{3.57}	SCREW 3.57	
6	159797001	1	イトサハ ^キ	LOWER THREAD FINGER	
7	062680712	1	ナヘ ^コ 437-40X7	SCREW 437X7	
8	159798001	1	イトキリホルダ ^タ	MOVABLE KNIFE HOLDER	
9	156620000	1	スラストサ ^ガ カ ^ネ	THRUST WASHER	
10	048180142	1	トメワシ ^ク ヨウC18	STOP RING C18	
12	159799001	1	イト ^ウ ハ	MOVABLE KNIFE	
13	148537001	2	サラネシ ^{4.37}	SCREW 4.37	
14	154576001	1	イトキリレンカン	THREAD TRIMMER CONNECTING ROD	
15	151987001	2	タ ^ン ネシ ^{4.37}	STUD SCREW 4.37	
16	102571003	1	ナツト ^{4.37}	NUT 4.37	
17	S01486001	1	イトキリレハ ^ー	THREAD TRIMMING LEVER	
18	S25437000	1	レハ ^ー ストツハ ^ク	THREAD TRIMMER LEVER STOPPER	
19	062711412	1	ナヘ ^コ 4.76-32X14	SCREW 476X14	
20	154579001	1	イトキリレハ ^ー ハ ^ネ	SPRING	
21	S02647001	1	フタマタシ ^ク	FORKED SHAFT	
22	154581001	1	フタマタシ ^ク メタル	FORKED SHAFT BUSH	
23	151607001	1	トメネシ ^{4.37}	SET SCREW 4.37	
24	154582001	1	イトキリカムレハ ^ー ク ^ミ	THREAD TRIMMER CAM LEVER ASSY	
25	154590001	1	コロシ ^ク ク ^ク ク ^ミ	ROLLER SHAFT (C) ASSY	
26	105234003	1	ナツト ^{4.37}	NUT 4.37	
27	014770622	1	アナトメネシ ^{6.35} クホ ^ミ	SET SCREW 6.35	
28	154593001	1	イトキリカムレハ ^ー シ ^ク	THREAD TRIMMER CAM LEVER SHAFT	
29	154594000	1	カラ ^ー	COLLAR	
30	154595001	1	カムレハ ^ー モト ^シ ハ ^ネ	SPRING	
31	154596000	1	イトキリカムレハ ^ー クツシヨ ^ン	CUSHION	
32	110367001	1	サ ^ガ カ ^ネ	WASHER	
33	048060342	1	トメワE6	STOP RING E6	
34	*	1	イトキリソレノイ ^ト	THREAD TRIMMER SOLENOID	
35	154598001	1	イトキリソレノイ ^ト タ ^イ	THREAD TRIMMER SOLENOID BRACKET	
36	154599000	1	ソレノイ ^ト クツシヨ ^ン	SOLENOID CUSHION	
37	S23836001	1	ソレノイ ^ト レハ ^ー ク ^ミ	SOLENOID LEVER ASSY	
37-1	S02654001	1	ソレノイ ^ト レハ ^ー	SOLENOID LEVER	
37-2	014680622	1	アナトメネシ ^{4.37} クホ ^ミ	SET SCREW 4.37	
39	110201001	1	シメネシ ^{6.35}	SCREW 6.35	
40	155558001	1	タ ^ン ネシ ^{6.35}	STUD SCREW 6.35	
41	146080009	1	コート ^ブ シユ	CORD BUSH	
42	140647001	1	コート ^オ サエ	CORD HOLDER	
43	062670612	1	ナヘ ^コ 357-40X6	SCREW 357X6	
45	*	1	ナイロンコネクタ12P	NYLON CONNECTOR 12P	
47	155559001	1	ヒラサ ^ガ カ ^ネ	PLAIN WASHER	
48	013670712	1	トメネシ ^{3.57} クホ ^ミ	SET SCREW 3.57	
49	155578000	1	ゴ ^ム セン	OIL CAP	
50	100645003	1	サ ^ガ カ ^ネ	WASHER	
51	340400001	1	ユニタイハ ^{ント}	BEAD BAND	
54	S02745001	1	サ ^ガ カ ^ネ	WASHER	
55	062680663	1	ナヘ ^コ 437-40X6	SCREW 437X6	
58	S02648001	1	カラ ^ー	COLLAR	
59	S02652001	1	サ ^ガ カ ^ネ	WASHER	
<-100>					
46	153970001	1	-----	CONNECTOR CAP 3	
<-300>					
46	153971001	1	コネクタキャツプ5	CONNECTOR CAP 5	
<D.C. モーター /D.C. MOTOR>					
53-1	S02682001	1	アースセンク ^ミ	EARTH WIRE ASSY	
53-1-1	S03328000	1	ピンターミナルオスL	TERMINAL PIN (L)(MALE)	
53-1-2	204569001	1	アツタンシ4.5X14	TERMINAL 4.5X14	
56	S11210000	1	Wコート ^ス ク ^ミ	W-CORD (S) ASSY	

L. 糸切り関係/Thread trimmer mechanism/Fadenabschneidevorrichtung/
 Mécanisme de coupe-fil/Mecanismo de la cortadura de hilos

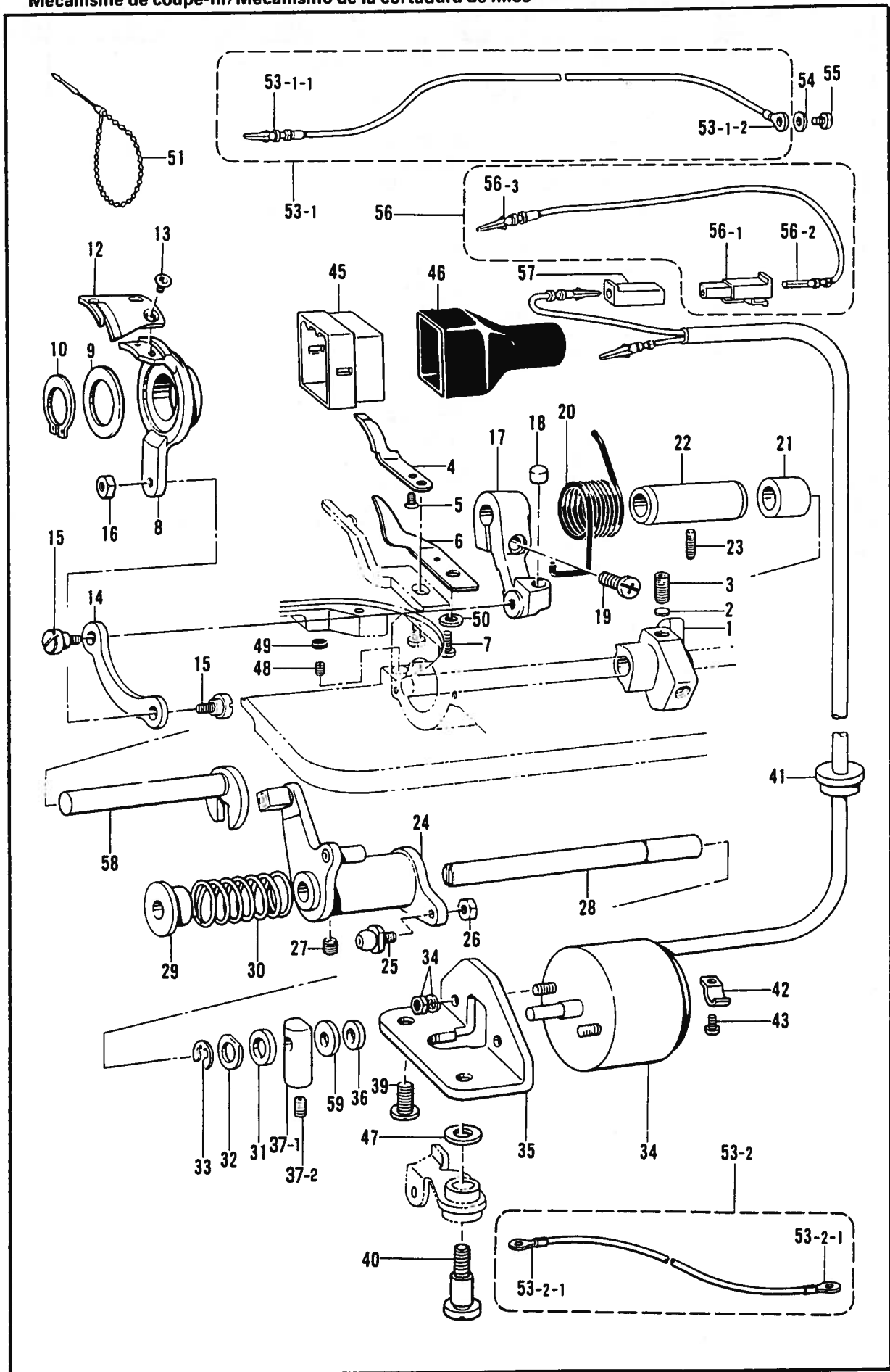

L. 糸切り関係/Thread trimmer mechanism/Fadenabschneidevorrichtung/
 Mécanisme de coupe-fil/Mecanismo de la cortadura de hilos

REF.NO.	CODE	QTY	品名	NAME OF PARTS	RMKS
56-1	S11684000	1	コネクタ3191-01R1	CONNECTER 3191-01R1	
56-2	143548000	1	ピンターミナルメス	TERMINAL PIN (FEMALE)	
56-3	143549000	1	ピンターミナルオス	TERMINAL PIN (MALE)	
57	S11683000	1	コネクタ3191-01P1	CONNECTER 3191-01P1	
<EFKA MOTOR>					
53-2	S06004001	1	-----	EARTH WIRE ASSY	
53-2-1	204569001	2	-----	TERMINAL 4.5X14	

M. 逆転スイッチ関係/Quick reverse switch mechanism/Umkehrschalter/
 Mécanisme de interrupteur de marche arrière rapide/Mecanismo del conmutador de inversión rápida

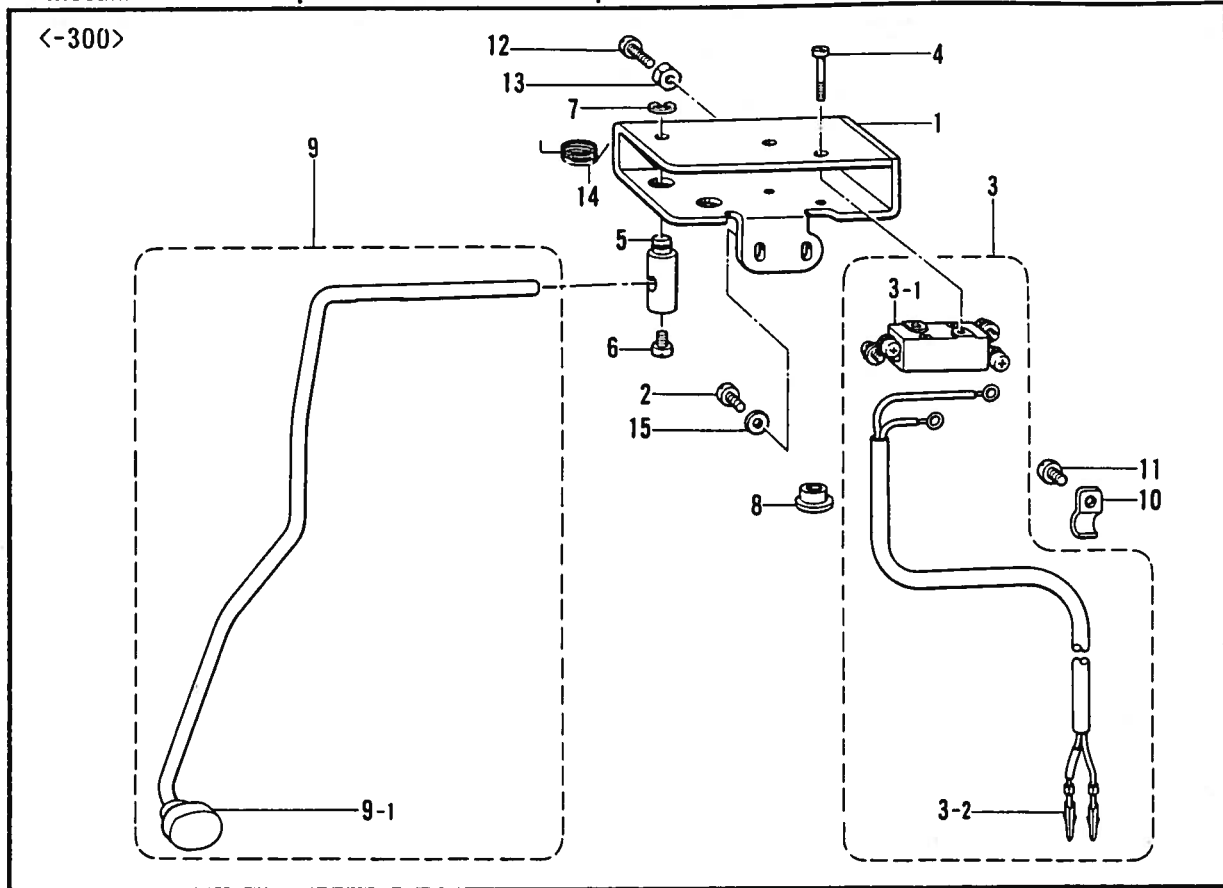

N. 針位置検出器関係/Synchronizer/Synchronisator/
 Synchronisateur/Sincronizador

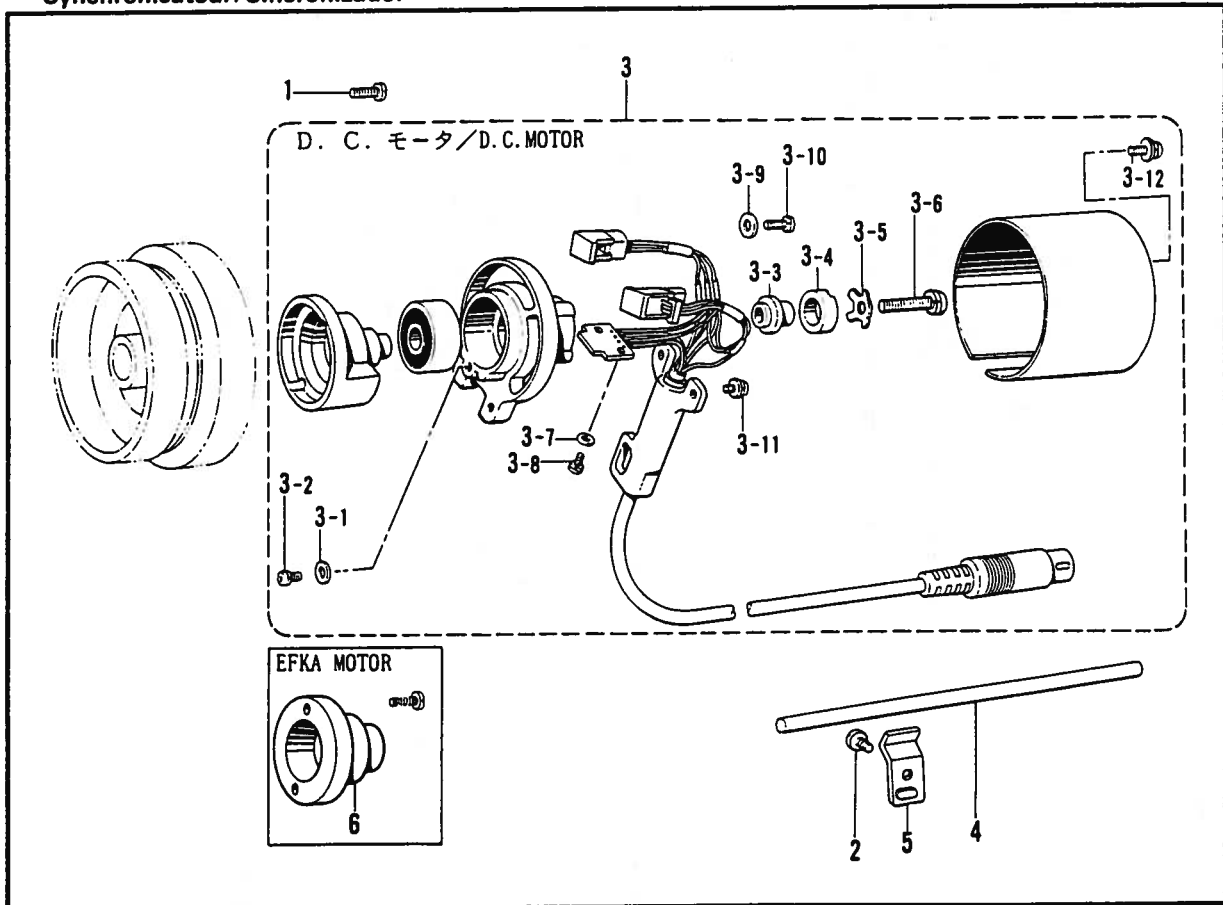

M. 逆転スイッチ関係/Quick reverse switch mechanism/Umkehrschalter/
 Mécanisme de interrupteur de marche arrière rapide/Mecanismo del conmutador de inversión rápida

REF.NO.	CODE	Q'TY	ヒンメイ	NAME OF PARTS	RMKS
<-300>					
1	156997009	1	マイクロスイッチタイ	MICRO SWITCH BASE	
2	062670812	2	ナヘコ357-40X8	SCREW 357X8	
3	*	1	Rスイッチクミ	REVERSE SWITCH ASSY	
3-1	140643000	1	マイクロスイッチ	MICRO SWITCH	
3-2	*	2	ピンターミナルオス	TERMINAL PIN (MALE)	
4	146124001	2	シメネシ2.38	SCREW 2.38	
5	156998001	1	アクチュエーターシャク	ACTUATOR SHAFT	
6	062681012	1	ナヘコ437-40X10	SCREW 437X10	
7	048040342	1	トメフE4	STOP RING E4	
8	146080009	1	コートブシユ	CORD BUSH	
9	S01511009	1	アクチュエータークミ	ACTUATOR ASSY	
9-1	156479009	1	オシホタン	PUSH BUTTON	
10	140647001	3	コートオサエ	CORD HOLDER	
11	062670612	3	ナヘコ357-40X6	SCREW 357X6	
12	062681412	1	ナヘコ437-40X14	SCREW 437X14	
13	102571003	1	ナツト4.37	NUT 4.37	
14	157999001	1	ハーモトシハネ	SPRING	
15	025350332	2	ヒラサガネタイ3.5	PLAIN WASHER 3.5	

N. 針位置検出器関係/Synchronizer/Synchronisator/
 Synchronisateur/Sincronizador

REF.NO.	CODE	Q'TY	ヒンメイ	NAME OF PARTS	RMKS
1	062711412	2	ナヘコ4.76-32X14	SCREW 476X14	
2	110201001	1	シメネシ6.35	SCREW 6.35	
4	218944001	1	シンクロナイザホルダー#2	SYNCHRONIZER HOLDER BAR	
5	216332001	1	ホルダー	HOLDER	
<D.C. モータ /D.C. MOTOR>					
3	238021001	1	シンクロナイザクミ#12G2	SYNCHRONIZER ASSY #12G2	
3-1	025030335	1	ヒラサガネタイ3	PLAIN WASHER 3	
3-2	215083001	1	+ナヘセット3X6D	WASHER SCREW 3X6D	
3-3	219557000	1	ジシヤクトリツケタイ	MAGNET FIXED BRACKET	
3-4	219558000	1	ジシヤク12X18.7X6	MAGNET (12X18.7X6)	
3-5	219559001	1	ジシヤクオサエイタ	MAGNET HOLDER PLATE	
3-6	221421001	1	+ナヘセット6X25D	SCREW 6X25D	
3-7	025030135	2	ヒラサガネシヨウ3	PLAIN WASHER 3	
3-8	215083001	2	+ナヘセット3X6D	WASHER SCREW 3X6D	
3-9	025040335	2	ヒラサガネタイ4	PLAIN WASHER 4	
3-10	217093001	2	+ナヘセット4X12D	WASHER SCREW 4X12D	
3-11	215082001	2	+ナヘセット4X12DA	WASHER SCREW 4X12DA	
3-12	224508001	2	+ナヘセット4X10DC	WASHER SCREW 4X10DC	
<EFKA MOTOR>					
6	148825001	1	-----	SLIP RING JOINT	

Z1. 付属品関係 / Accessories / Zubehör / Accessoires / Accesorios

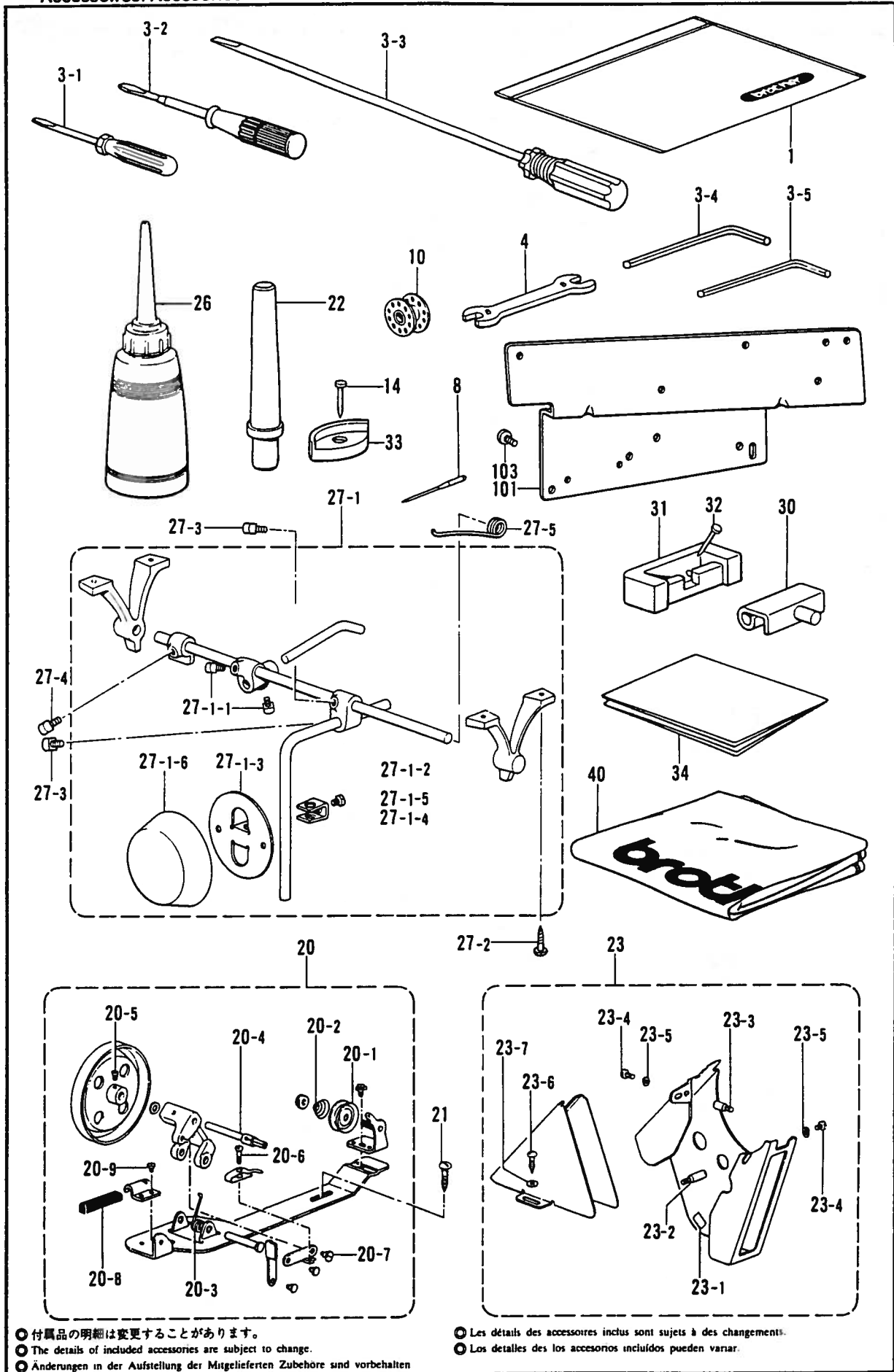

① 付属品の明細は変更することがあります。
 ② The details of included accessories are subject to change.
 ③ Änderungen in der Aufstellung der Mitgelieferten Zubehöre sind vorbehalten

① Les détails des accessoires inclus sont sujets à des changements.
 ② Los detalles de los accesorios incluidos pueden variar.

Z1. 付属品関係/Accessories/Zubehör/
Accessoires/Accessorios

REF.NO.	CODE	Q'TY	ヒンメイ	NAME OF PARTS	RMKS
1	122991001	1	フジクヒンホリフクロ	ACCESSORY BAG	
3-1	142443001	1	ネジマワシ1.9X52	SCREW DRIVER 1.9X52	
3-2	118837001	1	ネジマワシ3.4X70	SCREW DRIVER 3.4X70	
3-3	S17774001	1	ネジマワシ4.7X250	SCREW DRIVER 4.7X250	
3-4	146049001	1	6カクホウスハナ2	HEXAGONAL WRENCH 2	
3-5	142721001	1	6カクホウスハナ3	-----	
4	100887001	1	スハナ8X9	SPANNER 8X9	
8	145646023	4	ミシンハリDPX17(#23)	NEEDLE DPX17 (#23)	
10	S01587001	3	ホヒン	BOBBIN	
20	117963110	1	イトマキキクミ	BOBBIN WINDER ASSY	
20-1	145446001	2	イトチヨウシサラ	TENSION DISC	
20-2	100401001	1	イトチヨウシハネ	TENSION SPRING	
20-3	117969001	1	イトマキジクウケカエリハネ	SPRING	
20-4	117970001	1	イトマキジク	BOBBIN WINDER SHAFT	
20-5	100366002	1	マルヒラトメネジ4.37X5	SET SCREW 4.37X5	
20-6	100657001	1	シメネジ3.18	SCREW 3.18	
20-7	100659001	1	タムネジ3.18	STUD SCREW 3.18	
20-8	100662001	1	イトマキクルマカイテントメ	BOBBIN WINDER WHEEL STOPPER	
20-9	S01297001	1	シメネジ3.57X3.5	SCREW 3.57X3.5	
21	100666002	2	マルモクネジ5.5X20	SCREW 5.5X20	
22	100477009	1	マクラ	HEAD REST	
23	S06117109	1	ベルトカハークミE	BELT COVER ASSY (E)	
23-1	146289001	1	クッション7X12	CUSHION 7X12	
23-2	147855002	1	ベルトカハースタットA	BELT COVER STUD (A)	
23-3	147856001	1	ベルトカハースタットB	BELT COVER STUD (B)	
23-4	062680812	2	ナヘコ437-40X8	SCREW 437X8	
23-5	028680242	2	ハネサカネ2-4.37	SPRING WASHER 2-4.37	
23-6	100666002	2	マルモクネジ5.5X20	SCREW 5.5X20	
23-7	025750132	2	ヒラサカネシヨウ5.56	PLAIN WASHER 5.56	
26	114483002	1	ホリオイルークミ	OILER ASSEMBLY	
27	110845109	1	-----	KNEE LIFTER SEVICE	
27-1	180815201	1	-----	KNEE LIFTER ASSY	
27-1-1	100463001	2	-----	BOLT 7.94	
27-1-2	104619002	1	-----	KNEE LIFTER BAR	
27-1-3	114966001	1	-----	KNEE LIFTER PLATE	
27-1-4	114967001	1	-----	KNEE LIFTER PLATE STOPPER	
27-1-5	110087001	1	-----	BOLT 5.95	
27-1-6	140503001	1	-----	KNEE LIFTER PLATE COVER	
27-2	031512000	4	-----	SCREW 5.1X20	
27-3	100463001	2	-----	BOLT 7.94	
27-4	100463001	1	-----	BOLT 7.94	
27-5	145722101	1	-----	SPRING	
30	143882001	2	トウフヒンジ	HEAD HINGE	
31	143910009	2	トウフヒンジウケゴム	RUBBER CUSHION	
32	109714000	8	クキ	NAIL	
33	148890109	4	トウフシキゴム	HEAD CUSHION	
34	149994001	1	テーブルアナカコウス	TABLE SHEET	
40	144222001	1	-----	HEAD COVER	
<D.C. MOTOR>					
101	233088002	1	-----	HINGE SETTING PLATE (#1)	
103	060671212	2	-----	SCREW 357X12	

Z2. 付属品関係/Accessories/Zubehör/
Accessoires/Accesorios

OPTION PARTS

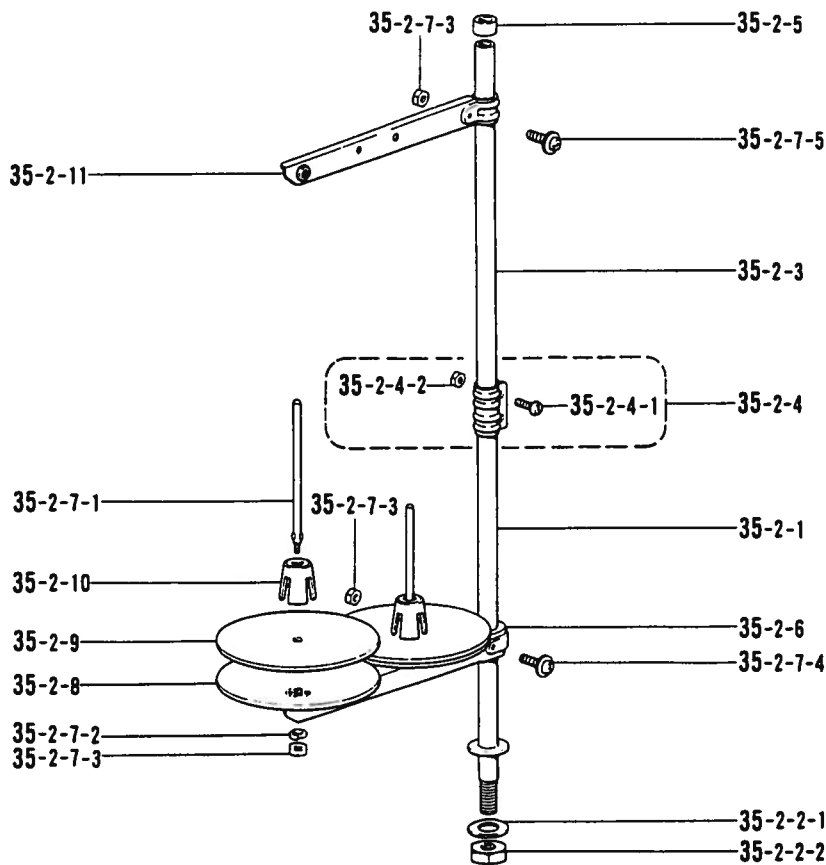
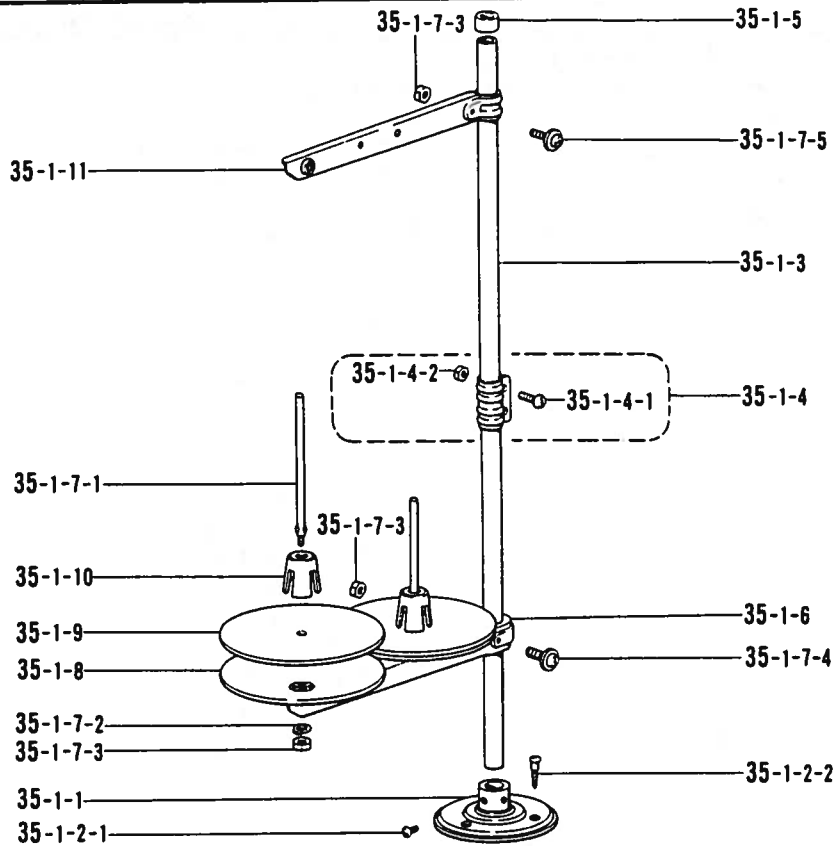

○ 付属品の明細は変更することがあります。
○ The details of included accessories are subject to change.
○ Änderungen in der Aufstellung der Mitgelieferten Zubehöre sind vorbehalten.

○ Les détails des accessoires inclus sont sujets à des changements
○ Los detalles de los accesorios incluidos pueden variar.

22. 付属品関係/Accessories/Zubehör/
Accessoires/Accessorios

REF.NO.	CODE	QTY	ヒンメイ	NAME OF PARTS	RMKS
<OPTION PARTS>					
35-1	S02761109	1	-----	COTTON STAND ASSY	
35-1-1	150189109	1	-----	COTTON STAND BASE	
35-1-2	S02773001	1	-----	COTTON STAND BASE SCREW SET	
35-1-2-1	062060806	2	-----	SCREW 6X8	
35-1-2-2	031452206	3	-----	SCREW 45X22	
35-1-3	150172003	2	-----	COLUMN PIPE	
35-1-4	150106003	1	-----	COLUMN JOINT ASSY	
35-1-4-1	062501406	2	-----	SCREW 5X14	
35-1-4-2	021500106	2	-----	NUT 5	
35-1-5	150174000	1	-----	COLUMN CAP	
35-1-6	S02778002	1	-----	SPOOL HOLDER 2	
35-1-7	S02780001	1	-----	SPOOL SCREW SET 2	
35-1-7-1	150179002	2	-----	SPOOL SHAFT (B)	
35-1-7-2	028050246	2	-----	SPRING WASHER 2-5	
35-1-7-3	021500106	4	-----	NUT 5	
35-1-7-4	050503006	1	-----	WASHER SCREW 5X30	
35-1-7-5	050501406	1	-----	WASHER SCREW 5X14	
35-1-8	150180001	2	-----	SPOOL STAND BASE	
35-1-9	150182000	2	-----	SPOOL MAT	
35-1-10	126863001	2	-----	SPOOL CUSHION	
35-1-11	S02786002	1	-----	THREAD HANGER ASSY 2	
35-2	S02762009	1	-----	COTTON STAND ASSY 2D	
35-2-1	156112003	1	-----	COLUMN PIPE (D)	
35-2-2	S02775001	1	-----	PIPE SCREW SET (A)	
35-2-2-1	150206002	1	-----	PLAIN WASHER 16	
35-2-2-2	150191002	1	-----	NUT 5/8	
35-2-3	150172003	1	-----	COLUMN PIPE	
35-2-4	150106003	1	-----	COLUMN JOINT ASSY	
35-2-4-1	062501406	2	-----	SCREW 5X14	
35-2-4-2	021500106	2	-----	NUT 5	
35-2-5	150174000	1	-----	COLUMN CAP	
35-2-6	S02778002	1	-----	SPOOL HOLDER 2	
35-2-7	S02780001	1	-----	SPOOL SCREW SET 2	
35-2-7-1	150179002	2	-----	SPOOL SHAFT (B)	
35-2-7-2	028050246	2	-----	SPRING WASHER 2-5	
35-2-7-3	021500106	4	-----	NUT 5	
35-2-7-4	050503006	1	-----	WASHER SCREW 5X30	
35-2-7-5	050501406	1	-----	WASHER SCREW 5X14	
35-2-8	150180001	2	-----	SPOOL STAND BASE	
35-2-9	150182000	2	-----	SPOOL MAT	
35-2-10	126863001	2	-----	SPOOL CUSHION	
35-2-11	S02786002	1	-----	THREAD HANGER ASSY 2	

◎標準ゲージ/Standard Gauge

針板 Needle Plate		送り歯 Feed Dog	標準押え Standard Feet	
			送り足 Walking Foot	押え足 Presser Foot
C26	147322-101	S01489-001	150454-101	S01484-101

◎オプションゲージ/Option Gauge

パイピング用押え Feet for Piping		小物縫い用押え Narrow type feet for small parts		リバース押え Reverse Feet	
送り足 Walking Foot	押え足 Presser Foot	送り足 Walking Foot	押え足 Presser Foot	送り足 Walking Foot	押え足 Presser Foot
151847-001	151850-001	151851-001	151852-001	S04501-001	S04502-001
151848-001					
151849-001					

索引/INDEX/VERZEICHNIS/
INDEX/INDICE

CODE	REF.NO.	PAGE
S00337001	L - 1	22
S00888001	A - 6	2
S01297001	Z1 - 20-9	28
S01304001	F - 52	8
	G - 6-1	12
S01305001	E - 1	6
S01476001	F - 60	10
S01477000	C - 9	4
S01478001	C - 12	4
S01481001	C - 14	4
S01482001	C - 17	4
S01483001	C - 20	4
S01484101	D - 7	6
S01485009	D - 16	6
S01486001	L - 17	22
S01487001	D - 21-1	6
S01488001	D - 21-4	6
S01489001	F - 33	8
S01490001	F - 17-1	8
S01491001	F - 51	8
S01493001	E - 3	6
S01496009	E - 6	6
S01497001	H - 12	16
S01498000	H - 24	16
S01499000	K - 10	20
S01500001	K - 29	20
S01501001	K - 21	20
S01502000	J - 26	18
S01503001	J - 33	18
S01504001	B - 1	2
S01505009	B - 2	2
S01506001	B - 4	2
S01507001	B - 6	2
S01508001	B - 7	2
S01509001	B - 12	2
S01511009	M - 9	26
S01585009	J - 35	18
S01586001	F - 31	8
S01587001	H - 21	16
	Z1 - 10	28
S01588001	K - 30	20
S01589009	E - 5	6
S01598009	F - 21-3	8
S01599001	F - 9-1	8
S01600001	F - 9-3	8
S01601001	F - 9-2	8
S01886101	B - 14	2
S02321001	G - 42	12
S02322001	G - 41	12
S02647001	L - 21	22
S02648001	L - 58	22
S02652001	L - 59	22
S02654001	L - 37-1	22
S02682001	L - 53-1	22
S02745001	L - 54	22
S02761109	Z2 - 35-1	32
S02762009	Z2 - 35-2	32
S02773001	Z2 - 35-1-2	32
S02775001	Z2 - 35-2-2	32
S02778002	Z2 - 35-1-6	32
	Z2 - 35-2-6	32
S02780001	Z2 - 35-1-7	32
	Z2 - 35-2-7	32
S02786002	Z2 - 35-1-11	32
	Z2 - 35-2-11	32
S02815009	L - 34	22
S03307009	E - 5	6

CODE	REF.NO.	PAGE
S03328000	L - 53-1-1	22
S06004001	L - 53-2	24
S06117109	Z1 - 23	28
S06999001	F - 21-1	8
S07818009	L - 34	22
S07828009	M - 3	26
S07832009	E - 5	6
S07976001	D - 17	6
S09670001	C - 30	4
S11210000	L - 56	22
S11683000	L - 57	24
S11684000	L - 56-1	24
S13385001	D - 8	6
S14030000	J - 32	18
S17774001	Z1 - 3-3	28
S19652001	F - 19	8
S23836001	L - 37	22
S25437000	L - 18	22
S27846009	J - 15	18
013670712	L - 48	22
013760610	C - 7	4
	H - 9	16
013760712	D - 10	6
013761410	C - 13	4
	C - 3	4
	G - 33-1	12
	H - 11	16
014680622	L - 37-2	22
014770622	L - 27	22
014771022	L - 3	22
021500106	Z2 - 35-1-4-2	32
	Z2 - 35-1-7-3	32
	Z2 - 35-2-4-2	32
	Z2 - 35-2-7-3	32
025030135	N - 3-7	26
025030335	N - 3-1	26
025040335	N - 3-9	26
025350132	D - 26	6
025350332	M - 15	26
025750132	Z1 - 23-7	28
028050246	Z2 - 35-1-7-2	32
	Z2 - 35-2-7-2	32
028680242	G - 24	12
	G - 31-2	12
	Z1 - 23-5	28
031452206	Z2 - 35-1-2-2	32
031512000	Z1 - 27-2	28
046301620	G - 52	12
047501842	D - 21-5	6
048020342	B - 8	2
048040342	G - 56	14
	M - 7	26
048060342	D - 23	6
	L - 33	22
048150142	F - 50	8
048180142	L - 10	22
050501406	Z2 - 35-1-7-5	32
	Z2 - 35-2-7-5	32
050503006	Z2 - 35-1-7-4	32
	Z2 - 35-2-7-4	32
060670612	B - 10	2
	K - 17	20
060670812	G - 27	12
060671212	Z1 - 103	28
062060806	Z2 - 35-1-2-1	32
062501406	Z2 - 35-1-4-1	32
	Z2 - 35-2-4-1	32

CODE	REF.NO.	PAGE
062670412	K - 22	20
062670512	C - 21	4
062670612	J - 12	18
	J - 14	18
	J - 6	18
	L - 43	22
	M - 11	26
062670812	A - 7	2
	B - 13	2
	J - 7	18
	M - 2	26
062671412	G - 30	12
	G - 51	12
	K - 28	20
062680663	L - 55	22
062680712	J - 36	18
	K - 20	20
	L - 7	22
062680812	G - 23	12
	Z1 - 23-4	28
062681012	E - 7	6
	G - 31-1	12
	M - 6	26
062681212	F - 26-2	8
	G - 2	12
	H - 19	16
062681412	M - 12	26
062681612	F - 40-1	8
062710812	D - 22	6
	F - 58	10
062711412	E - 1-1	6
	F - 13-1-1	8
	F - 16	10
	L - 19	22
	N - 1	26
062751612	G - 39-1	12
	G - 44-1	12
081014670	J - 23	18
100032004	C - 27	4
100075004	F - 39-1	8
100080003	F - 34	8
100136001	K - 13	20
100248001	J - 27	18
100251001	C - 11	4
	H - 1-1-1	16
	H - 1-2-2	16
	H - 2-1-1	16
	H - 2-2-2	16
100257010	J - 24	18
100260001	C - 16	4
	C - 18	4
100279109	D - 3	6
100304001	D - 20	6
100310001	F - 36	8
100320002	H - 3-1	16
100328001	F - 25	8
100343001	H - 4-2	16
100366002	Z1 - 20-5	28
100398001	K - 6	20
100401001	Z1 - 20-2	28
100402004	K - 7	20
100463001	Z1 - 27-1-1	28
	Z1 - 27-3	28
	Z1 - 27-4	28
100477009	Z1 - 22	28
100511003	F - 18	8
100645003	L - 50	22

CODE	REF.NO.	PAGE
100657001	Z1 - 20-6	28
100659001	Z1 - 20-7	28
100662001	Z1 - 20-8	28
100666002	Z1 - 21	28
	Z1 - 23-6	28
100887001	Z1 - 4	28
101706001	F - 48-1	8
	G - 13-1	12
	H - 16-1	16
102571003	L - 16	22
	M - 13	26
102627001	F - 9-1-1	8
102630001	C - 19	4
102843004	L - 5	22
103013001	D - 1	6
103738001	H - 23	16
103796001	H - 5	16
103797001	H - 6	16
103950003	K - 5	20
104451009	J - 20	18
104464001	C - 10	4
104547001	J - 21	18
104619002	Z1 - 27-1-2	28
104689002	F - 37	8
	F - 7	8
	G - 8	12
104908001	F - 32	8
105161003	G - 30-1	12
105234003	L - 26	22
106440000	F - 1-3	8
106442001	F - 1-2	8
107453001	G - 37	12
108541001	F - 17-2	10
108549001	F - 21-6	8
108749001	F - 14	10
108805001	J - 28	18
109152001	F - 26-1	8
	G - 1	12
109153001	F - 27	8
	G - 3	12
109714000	J - 16	18
	Z1 - 32	28
109893002	G - 57	14
110087001	Z1 - 27-1-5	28
110161004	B - 3	2
110201001	L - 39	22
	N - 2	26
110320000	H - 4-1	16
110367001	C - 35	4
	L - 32	22
110778002	G - 16	12
	G - 38	12
110845109	Z1 - 27	28
111491001	F - 9-1-2	8
111865009	J - 30	18
112735000	J - 31	18
113730001	K - 26	20
114255001	J - 19	18
114483002	Z1 - 26	28
114486002	J - 17	18
114561001	C - 28-1	4
114966001	Z1 - 27-1-3	28
114967001	Z1 - 27-1-4	28
115812002	J - 18	18
116112001	K - 14	20
116662003	F - 57	8
116735000	C - 12-3	4

CODE	REF.NO.	PAGE
116920001	F - 49	8
116947000	C - 34	4
116953001	F - 13-2	10
116995001	F - 38	8
117116001	C - 15	4
117963110	Z1 - 20	28
117969001	Z1 - 20-3	28
117970001	Z1 - 20-4	28
118293001	F - 35	8
118298001	H - 4	16
118475002	K - 24	20
118550001	D - 21-2	6
118762000	H - 13	16
118768001	J - 25	18
118837001	Z1 - 3-2	28
122771002	C - 28-2	4
122991001	Z1 - 1	28
126863001	Z2 - 35-1-10	32
	Z2 - 35-2-10	32
129458102	F - 21-5	8
129500010	F - 21-2	8
132051001	C - 12-1	4
140004001	C - 12-2	4
140378001	H - 1	16
140384001	H - 3	16
140503001	Z1 - 27-1-6	28
140553102	C - 22	4
140560001	J - 1	18
140643000	M - 3-1	26
140647001	B - 11	2
	L - 42	22
	M - 10	26
141099001	D - 5	6
141744009	J - 3	18
141748001	F - 59	10
142443001	Z1 - 3-1	28
142481001	D - 14	6
142721001	Z1 - 3-5	28
142746002	F - 21-4	8
143548000	L - 56-2	24
143549000	E - 5-2	6
	L - 56-3	24
	M - 3-2	26
143882001	Z1 - 30	28
143910009	Z1 - 31	28
144222001	Z1 - 40	28
144504001	K - 32	20
144523001	D - 19	6
144551001	C - 1	4
144552000	C - 2	4
144560001	D - 21-3	6
144712001	F - 35-1	8
145250001	K - 4	20
145446001	K - 9	20
	Z1 - 20-1	28
145502001	F - 24	8
145621001	J - 34	18
145646023	C - 25	4
	Z1 - 8	28
145722101	Z1 - 27-5	28
146049001	Z1 - 3-4	28
146080009	L - 41	22
	M - 8	26
146121009	M - 3	26
146124001	M - 4	26
146141001	F - 12	8
146289001	Z1 - 23-1	28

CODE	REF.NO.	PAGE
147322001	C - 26	4
147337001	H - 18	16
147338009	K - 19	20
147339001	K - 16	20
147503009	F - 15-2	10
147557101	K - 1	20
147767001	F - 30	8
147846002	D - 27	6
147855002	Z1 - 23-2	28
147856001	Z1 - 23-3	28
148537001	L - 13	22
148608101	F - 55	8
148806001	J - 11	18
148823009	C - 29	4
148825001	N - 6	26
148890109	Z1 - 33	28
148897100	C - 6	4
148913000	H - 8	16
148914000	H - 10	16
148918000	J - 2	18
148923001	K - 8	20
148924101	K - 12	20
149091001	F - 56	8
149135101	B - 9	2
149204001	F - 6	8
	G - 7	12
149994001	Z1 - 34	28
150106003	Z2 - 35-1-4	32
	Z2 - 35-2-4	32
150172003	Z2 - 35-1-3	32
	Z2 - 35-2-3	32
150174000	Z2 - 35-1-5	32
	Z2 - 35-2-5	32
150179002	Z2 - 35-1-7-1	32
	Z2 - 35-2-7-1	32
150180001	Z2 - 35-1-8	32
	Z2 - 35-2-8	32
150182000	Z2 - 35-1-9	32
	Z2 - 35-2-9	32
150189109	Z2 - 35-1-1	32
150191002	Z2 - 35-2-2-2	32
150206002	Z2 - 35-2-2-1	32
150430001	G - 28	12
150435001	H - 2	16
150437001	F - 5	8
150439101	F - 29	8
150440000	F - 44	8
150441000	F - 46	8
150442001	G - 5	12
150444000	G - 10	12
150445000	G - 11	12
150446001	G - 14	12
150450001	G - 20	12
150451001	G - 21	12
	G - 46	12
150452001	G - 22	12
150454101	G - 26	12
150459001	G - 45	12
150460001	G - 35	12
150461001	G - 36	12
150463001	G - 40	12
150465001	G - 34	12
150466001	G - 47	12
150467001	G - 48	12
150468001	G - 49	12
150469001	G - 50	12
150470001	H - 7	16

CODE	REF.NO.	PAGE
150473000	H - 14	16
150474009	J - 5	18
150475000	J - 9	18
150476000	J - 10	18
150477001	J - 13	18
150479001	K - 25	20
150480001	K - 27	20
150481001	D - 2	6
150482001	D - 4	6
150483001	D - 9	6
150486201	D - 18	6
150488000	F - 45	8
150491001	G - 18	12
150501001	G - 6	12
150502101	G - 15	12
150503101	G - 33	12
150504001	G - 39	12
150505001	G - 44	12
150731101	D - 21	6
150815009	J - 29	18
151074009	J - 22	18
151086000	D - 25	6
151185009	M - 3	26
151594001	C - 23	4
151602002	F - 28	8
	G - 4	12
	K - 15	20
	K - 3	20
151603002	H - 25	16
151604001	C - 8-1	4
	F - 1-1	8
151604002	F - 47	8
	G - 12	12
	G - 19	12
	G - 43	12
151607001	H - 15	16
	L - 23	22
151844001	H - 20-4	16
151845001	H - 20	16
151987001	L - 15	22
153512001	G - 25	12
153513001	G - 29	12
153514001	G - 17	12
153969000	L - 45	22
153970001	L - 46	22
153971001	L - 46	22
154559001	K - 31	20
154562001	K - 33	20
154563001	K - 35	20
154567000	L - 2	22
154568101	L - 4	22
154576001	L - 14	22
154579001	L - 20	22
154581001	L - 22	22
154582001	L - 24	22
154590001	L - 25	22
154593001	L - 28	22
154594000	L - 29	22
154595001	L - 30	22
154596000	L - 31	22
154598001	L - 35	22
154599000	L - 36	22
155510001	K - 34	20
155558001	L - 40	22
155559001	L - 47	22
155578000	L - 49	22
156112003	Z2 - 35-2-1	32

CODE	REF.NO.	PAGE
156362009	F - 15-1	8
156479009	M - 9-1	26
156620000	L - 9	22
156626009	L - 34	22
156982001	E - 4	6
156997009	M - 1	26
156998001	M - 5	26
157981000	E - 5-1	6
157999001	M - 14	26
159113001	B - 5	2
159793001	H - 17	16
159797001	L - 6	22
159798001	L - 8	22
159799001	L - 12	22
159805001	K - 11	20
159991001	D - 15	6
159992001	G - 32	12
159993001	G - 31	12
159994001	G - 54	12
159995001	G - 55	12
159996001	G - 53	12
159997009	K - 18	20
180018101	C - 28	4
180815201	Z1 - 27-1	28
180987001	F - 39	8
181647001	F - 1	8
181936001	H - 20-1	16
181937001	H - 20-2	16
181938001	H - 20-3	16
181940001	C - 8	4
181941101	F - 40	8
181995001	H - 16	16
183238001	F - 13-1	8
183366001	F - 9	8
183493001	F - 48	8
	G - 13	12
183772009	F - 21	8
204569001	L - 53-1-2	22
	L - 53-2-1	24
215082001	N - 3-11	26
215083001	N - 3-2	26
	N - 3-8	26
216332001	N - 5	26
217093001	N - 3-10	26
218944001	N - 4	26
219557000	N - 3-3	26
219558000	N - 3-4	26
219559001	N - 3-5	26
221421001	N - 3-6	26
224508001	N - 3-12	26
233088002	Z1 - 101	28
238021001	N - 3	26
340400001	L - 51	22

brother

ブラザー工業株式会社

〒467 名古屋市瑞穂区河岸一丁目1番1号
TEL (052) 824-2392代

BROTHER INDUSTRIES, LTD. NAGOYA, JAPAN

117-798
195798-201
1993, 04