

DB2-C111

零件手册

パーツブック

PARTS BOOK

高速平缝机

高速一本針本縫マシン

High Speed Lockstitch Sewing Machine

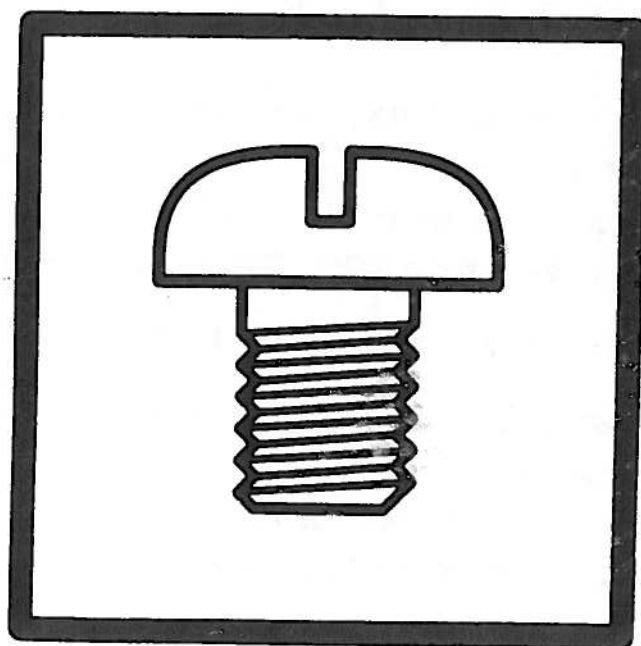

BROTHER INDUSTRIES, LTD. NAGOYA JAPAN

DB2-C111-

薄料用

1. 薄物用

Thin materials

中厚料用

3. 中厚物用

Medium-thick materials

厚料用

5. 厚物用

Thick materials

使用零件样本时请注意

1. 此样本是根据一九九四年五月的数据而制成的。(一九九六年六月重新修订)
2. 零件进行更改设计时,恕不预先通知。
3. 零件以组件为单位补充时用 进行表示。
4. 在零件号码栏里有※记号的,请在各种规格用零件一览表(19~20页)中查询。

パーツブックご利用に際して

1. この本は、1994年5月のデータに基づいて作成されたものです。
2. 部品は予告なしに設計変更される場合があります。
3. 組単位で補給する部品は、 破線で示しております。
4. 部品コード欄が※となっている場合は、仕様別部品一覧表(19~20ページ)でお調べ下さい。

ATTENTION

1. This Catalogue is made according to the data of May in 1994.
2. Excuse for not noticement in advance while the design of the spare part has to be changed.
3. The part is indicated with when supplement taking the complete as a unit.
4. With the signal ※ in the column of part No., please check them in the form page 19-20.

目 次

L I S T

A.	机壳部分	
	主体関係	1
	Machine body	
B.	压脚机构	
	押工関係	1
	Presser foot mechanism	
C.	针杆・挑线机构	
	针棒・天秤関係	3
	Needle bar and thread take up mechanism	
D.	送料机构	
	送り関係	5
	Feed mechanism	
E.	旋梭机构(竖轴下轴)	
	カマ関係	9
	Rotary hook mechanism	
F.	供油润滑机构	
	给油润滑関係	11
	Lubrication	
G.	过线压线机构	
	糸通シ関係	13
	Threading mechanism	
H.	膝控机构	
	膝上ゲ関係	13
	Knee lifter mechanism	
Z.	附件部分	
	付属品関係	15
	Accessories	
	各种规格用零件一览表	
	仕様別部品一覧表	19
	DIFFERENT PARTS LIST	
	索引/INDEX/VERZEICHIS/	21
	INDEX/INDICE	

A. 机壳部分/主体關係/Machine body/

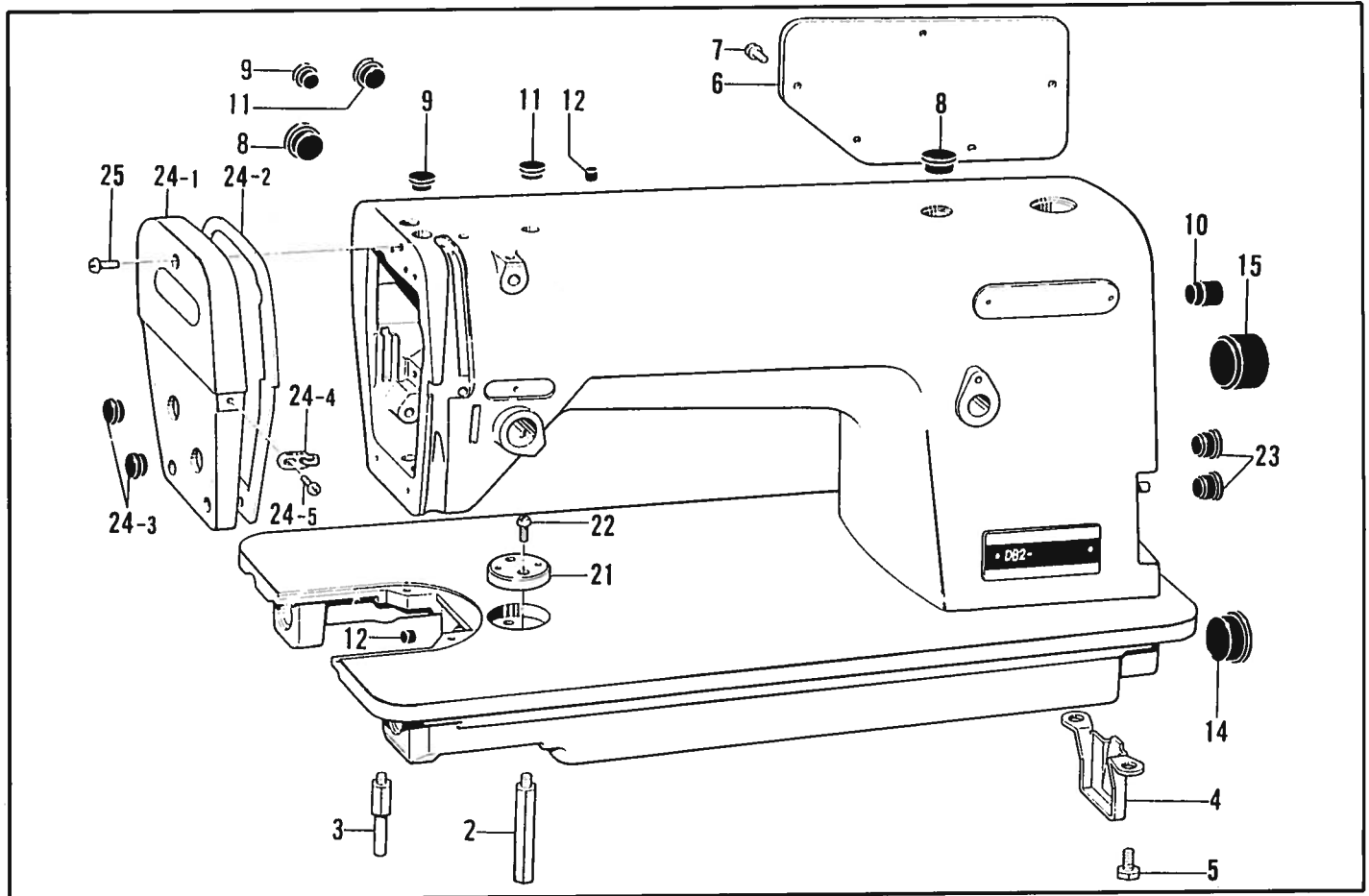

877-111-050

B. 压脚机构/押工關係/Pressor foot mechanism/

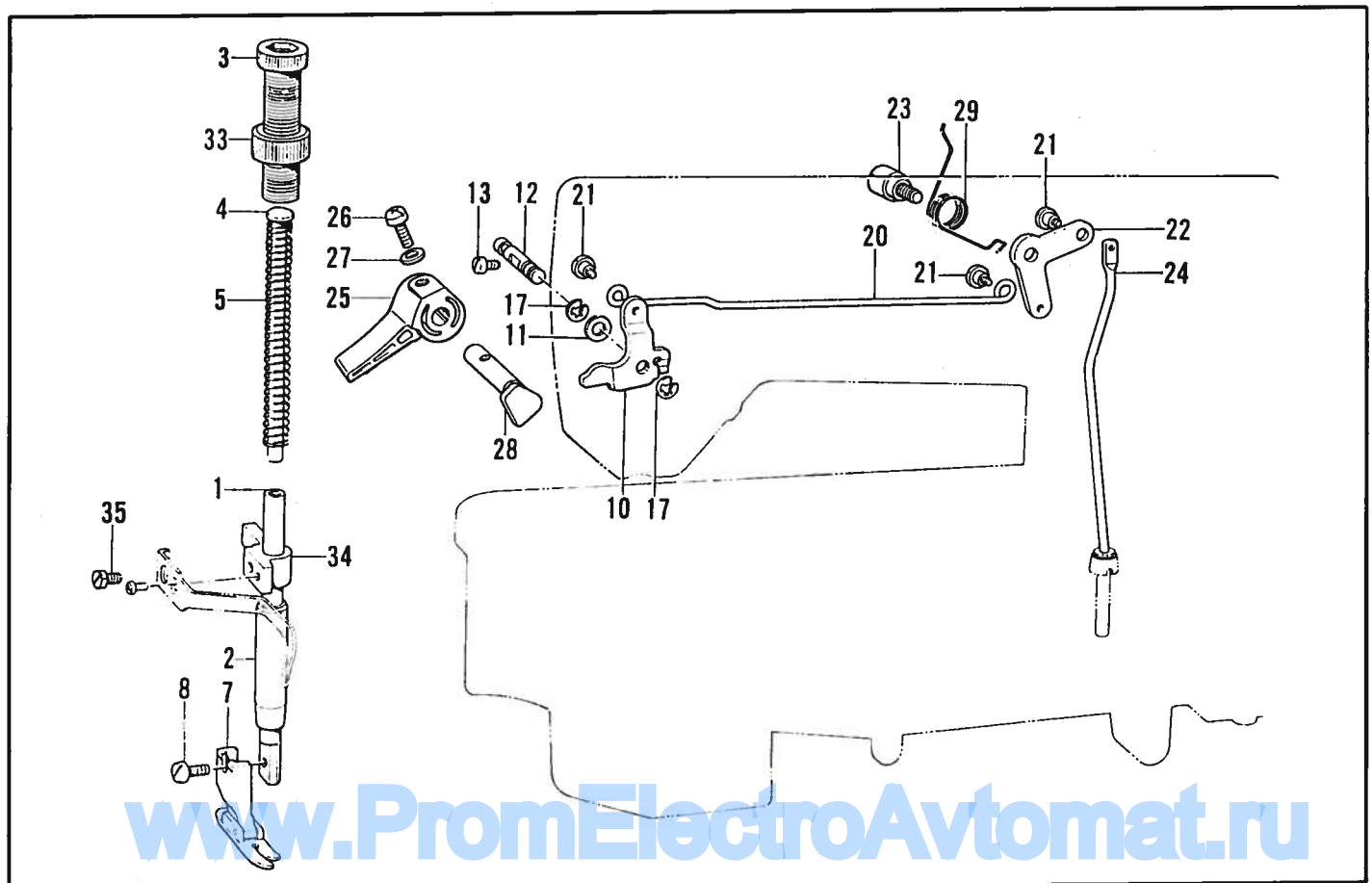

877-111-201

A. 机壳部分/主体関係/Machine body/

REE. NO.	CODE	Q'TY	ヒンメイ	NAME OF PARTS	零件名称
2	104829121	1	キヤクチュウL	BED LEG(L)	机壳长支撑杆 L
3	104830121	1	キヤクチュウス	BED LEG(S)	机壳短支撑杆 S
4	118672021	1	ポンプカバー	PUMP COVER	机壳支撑板
5	140704021	2	ボルト7.14	BOLT, SM7. 14	机壳支撑板螺钉 SM7. 14
6	※	1	ガワイタ	REAR COVER	后盖板
7	062681012	5	ナベコ437-40×10	SCREW, PAN SM4. 37-40×10	园柱头螺钉 SM4. 37-40×10
8	104449009	2	ゴムセン15.5	OIL CAP	橡皮塞
9	104450109	2	ゴムセン8	OIL CAP	橡皮塞
10	104832009	1	ゴムセン10.7	OIL CAP	橡皮塞
11	104821009	2	ゴムセン10.5	OIL CAP	橡皮塞
12	142274009	2	ゴムセン4.2	OIL CAP	橡皮塞
14	108520009	1	ゴムセン19.8	OIL CAP	橡皮塞
15	104451009	1	ゴムセン23.9	OIL CAP	橡皮塞
21	S09621021	1	ジヨウギイタ	RULER PLATE	夹边座
22	062670612	1	ナベコ357-40×6	SCREW, PAN SM3. 57-40×6	园柱头螺钉 SM3. 57-40×6
23	104450109	2	ゴムセン8	OIL CAP	橡皮塞
24	※	1	メンイタクミ	FACE PLATE ASSY	面板配件
24-1	S35526021	1	メンイタ	FACE PLATE	面板
24-2	S35529020	1	メンイタパツキン	FACE PLATE PACKING	面板垫片
24-3	104449009	2	ゴムセン15.5	OIL CAP	橡皮塞
24-4	S02617001	1	メンイタイトアンナイ	FACE PLATE THREAD GUIDE	面板线勾
24-5	060670612	1	バインド357-40×6	SCREW, BIND SM3. 57-40×6	园柱头螺钉 SM3. 57-40×6
25	062671012	3	ナベコ357-40×10	SCREW, PAN SM3. 57-40×10	园柱头螺钉 SM3. 57-40×10

877-111-050

B. 压脚机构/押工関係/Pressor foot mechanism/

REE. NO.	CODE	Q'TY	ヒンメイ	NAME OF PARTS	零件名称
1	111466121	1	オサエボウ	PRESSER BAR	压紧杆
2	145472021	1	オサエボウメタル	PRESSER BAR BUSH	压紧杆轴套
3	S31012021	1	オサエチヨウセツネジ	ADJUST SCREW	调压螺钉
4	141208021	1	オサエバネアンナイ	SPRING GUIDE	压紧弹簧导柱
5	※	1	オサエバネ	SPRING	压紧弹簧
7	※	1	オサエクミ	PRESSER FOOT ASSY	压脚组件
8	S13385001	1	シメネジ3.57×10	SCREW, SM3. 57×10	螺钉 SM3. 57×10
10	S01020022	1	オサエアゲレバー	PRESSER BAR LIFTER	膝控提升左杠杆
11	109763022	1	ザガネ	WASHER	左杠杆垫圈
12	159998121	1	オサエアゲレバーシク	PRESSER BAR LIFTER SHAFT	膝控提升杠杆左销
13	S01998001	1	アタマツキトメネジ3.57	SET SCREW, SM3. 57	螺钉 SM3. 57
17	048040342	2	トメワE4	RETAINING RING, E4	挡圈 E4
20	145476021	1	ヒザアゲレンカン	KNEE LIFTER CONNECTING ROD	膝控提升拉杆
21	145478022	3	ダンネジ4.76	SHOULDER SCREW, SM4. 76	提升拉杆螺钉 SM4. 76
22	145479022	1	ヒザアゲレバー	KNEE LIFTER LEVER	膝控提升右杠杆
23	S31010021	1	ダンシク6.35	SHOULDER SCREW, SM6. 35	膝控提升复位簧螺钉 SM6. 35
24	145481021	1	ヒザアゲボウ	KNEE LIFTER BAR	膝控提升连杆
25	S31006021	1	オサエアゲテコ	PRESSER BAR LIFTER	压脚扳手
26	062351216	1	ナベコ35×12	SCREW, PAN, SM3. 5×12	螺钉 SM3. 5×12
27	102707021	1	ザガネ	WASHER	压脚扳手螺钉垫圈
28	S31952021	1	オサエアゲクランク	PRESSER BAR LIFTER CRANK	压紧杆提升凸轮
29	154347001	1	ヒザアゲレバーバネ	SPRING	弹簧
33	S31013021	1	チヨウセツネジツマミナツト	NUT	调压锁紧螺母
34	S00879021	1	オサエボウダキ	PRESSER BAR GUIDE BRACKET	压紧杆导架
35	142403001	1	ボルト5.95	BOLT, SM5. 95	螺栓 SM5. 95

877-111-201

C. 针杆·挑线机构/針棒·天秤關係/Needle bar and thread take-up mechanism/

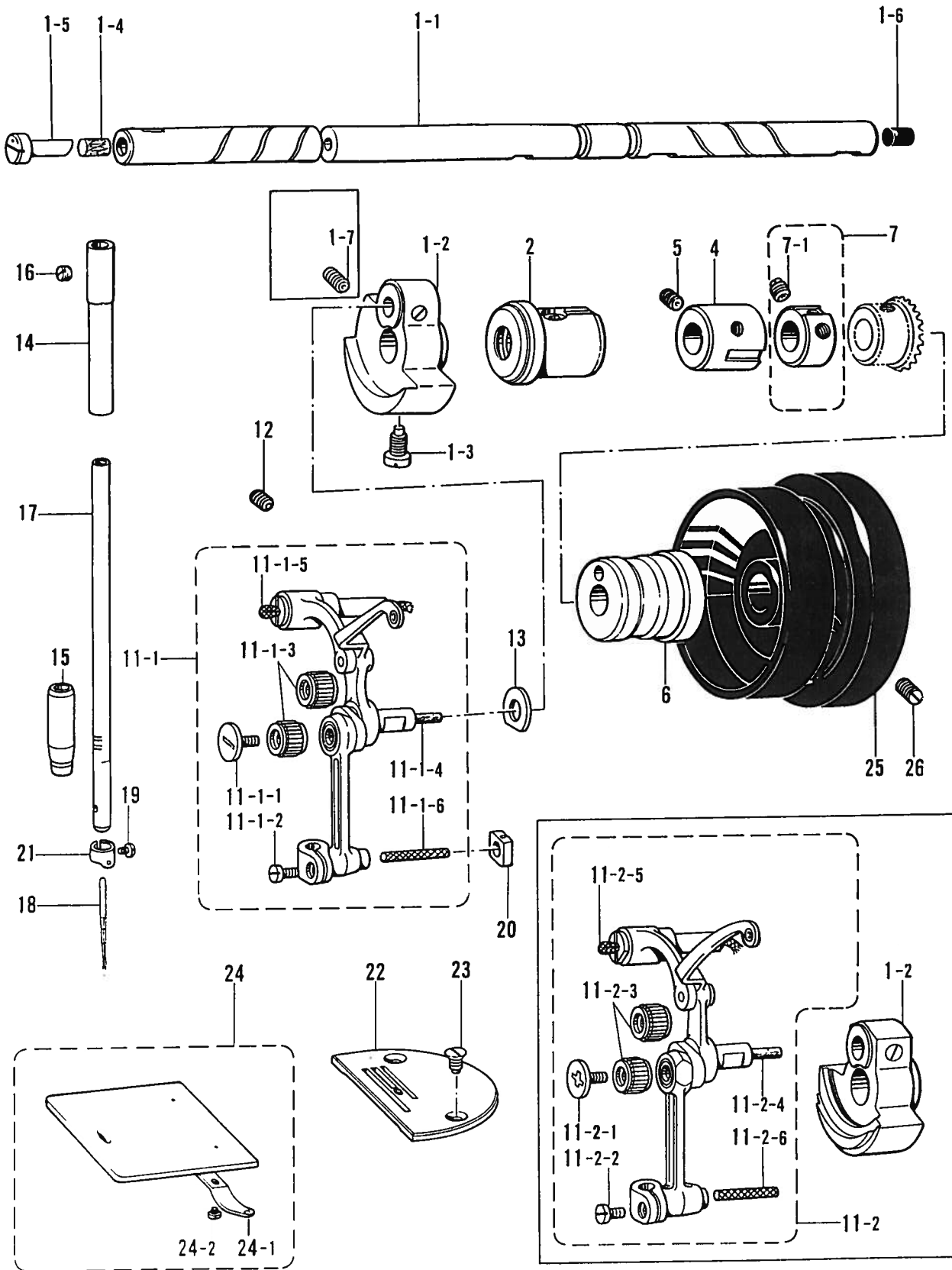

www.PromElectroAvtomat.ru

C. 针杆・挑线机构/针棒・天秤関係/Needle bar and thread take-up mechanism/

REE. NO.	CODE	Q'TY	ヒンメイ	NAME OF PARTS	零件名称
2	S37815021	1	ウワジクメタルL	UPPER SHAFT BUSH(L)	上轴左轴套
4	140726020	1	ウワジクメタルM	UPPER SHAFT BUSH(M)	上轴中轴套
5	013760610	1	トメネジ5.95クボミ	SET SCREW,(CP)SM5.95	固定螺钉 SM5.95
6	146331021	1	ウワジウメタルR	UPPER SHAFT BUSH(R)	上轴右轴套
7	181916121	1	セツトカラークミ	SET COLLAR ASSY	上轴紧圈配件
7-1	100251001	2	トメネジ6.35	SET SCREW,SM6.35	固定螺钉 SM6.35
12	013781012	1	トメネジ6.35クボミ	SET SCREW,(CP)SM6.35	固定螺钉 SM6.35
13	110367021	1	ザガネ	WASHER	挑线曲柄垫圈
14	117242021	1	ハリボウメタルU	NEEDLE BAR BUSH(U)	针杆上轴套
16	100260001	1	トメネジ5.95	SET SCREW,SM5.95	螺钉 SM5.95
17	※	1	ハリボウ	NEEDLE BAR	针杆组件
18	※	1	ミシンハリ	NEEDLE	机针
19	140553102	1	アタマツキトメネジ3.18	SET SCREW,SM3.18	螺钉 SM3.18
20	102630021	1	ハリボウアンナイカタコマ	NEEDLE BAR GUIDE SLIDE BLOCK	针杆接头滑块
22	※	1	ハリイタ	NEEDLE PLATE	针板
23	100032004	2	サラネジ4.37	SCREW,FLAT SM4.37	针板螺钉 SM4.37
24	180018121	1	スベリイタクミ	SLIDE PLATE ASSY	推板配件
24-1	114561021	1	スベリイタウラバネ	SPRING	推板簧
24-2	122771002	2	シメネジ2.38	SCREW,SM2.38	螺钉 SM2.38
26	S33689002	2	アタマトメクボミ595-14	SET SCREW,(CP)SM5.95-14	固定螺钉 SM5.95-14
<-1,3>					
1	S37812021	1	ウワジククミ	UPPER SHAFT ASSY	上轴组件
1-1	S37814021	1	ウワジク	UPPER SHAFT	上轴
1-2	S06325021	1	テンピンクランククミ	THREAD TAKE-UP CRANK ASSY	针杆曲柄配件
1-3	104464001	1	シメネジ7.14	SCREW,SM7.14	螺钉 SM7.14
1-4	146327021	1	フェルト7×10	FELT 7×10	上轴左油封 7×10
1-5	146333021	1	オイルチョウセツベン	OIL REGULATE VALVE	上轴左油塞
1-6	156641001	1	ゴムセン7.4	OIL CAP	橡皮塞
1-7	014771022	1	アナトメネジ6.35クボミ	SET SCREW,SOCKET(CP)SM6.35	固定螺钉 SM6.35
11-1	S34287021	1	ハリボウレンカククミ	THREAD TAKE-UP LEVER ASSY	挑线杆大配件
11-1-1	S13163001	1	シメネジ3.57L	SCREW,SM3.57L	螺钉 SM3.57L
11-1-2	140004001	1	シメネジ3.57	SCREW,SM3.57	螺钉 SM3.57
11-1-3	147777000	2	ニードルベアリング	NEEDLE BEARING	滚针轴承
11-1-4	145624000	1	フェルト	FELT	油毡
11-1-5	155488000	1	クミヒモ	WICK	油线
11-1-6	158727001	1	クミヒモ4×4	WICK 4×4(L=27)	油线 4×4(L=27)
15	S35817021	1	ハリボウメタルD	NEEDLE BAR BUSH(D)	针杆下轴套
21	S14814001	1	ハリボウイトアンナイ	NEEDLE BAR THREAD GUIDE	针杆过线环
<-5>					
1	S37813021	1	ウワジククミ	UPPER SHAFT ASSY	上轴组件
1-1	S37814021	1	ウワジク	UPPER SHAFT	上轴
1-2	S00909021	1	テンピンクランククミ	THREAD TAKE-UP CRANK ASSY	针杆曲柄配件
1-3	104464001	1	シメネジ7.14	SCREW,SM7.14	螺钉 SM7.14
1-4	146327021	1	フェルト7×10	FELT 7×10	上轴左油封 7×10
1-5	146333021	1	オイルチョウセツベン	OIL REGULATE VALVE	上轴左油塞
1-6	156641001	1	ゴムセン7.4	OIL CAP	橡皮塞
11-2	S34290021	1	ハリボウレンカククミ	NEEDLE TAKE-UP LEVER ASSY	挑线杆大配件
11-2-1	S13163001	1	シメネジ3.5L	SCREW 3.5L	螺钉 3.5L
11-2-2	140004001	1	シメネジ3.57	SCREW,SM3.57	螺钉 SM3.57
11-2-3	147777000	2	ニードルベアリング	NEEDLE BEARING	滚针轴承
11-2-4	145624000	1	フェルト	FELT	油毡
11-2-5	155488000	1	クミヒモ	WICK	油线
11-2-6	158727001	1	クミヒモ4×4	WICK 4×4(L=27)	油线 4×4(L=27)
15	147326021	1	ハリボウメタルD	NEEDLE BAR BUSH(D)	针杆下轴套
21	151594001	1	ハリボウイトアンナイ	NEEDLE BAR THREAD GUIDE	针杆过线环
<ブラザー用/For brother>					
25	145471029	1	プーリー	PULLEY
<For TYPICEL brother>					
25	115244028	1	PULLEY	上轮

D. 送料机构/送り関係/Feed mechanism/

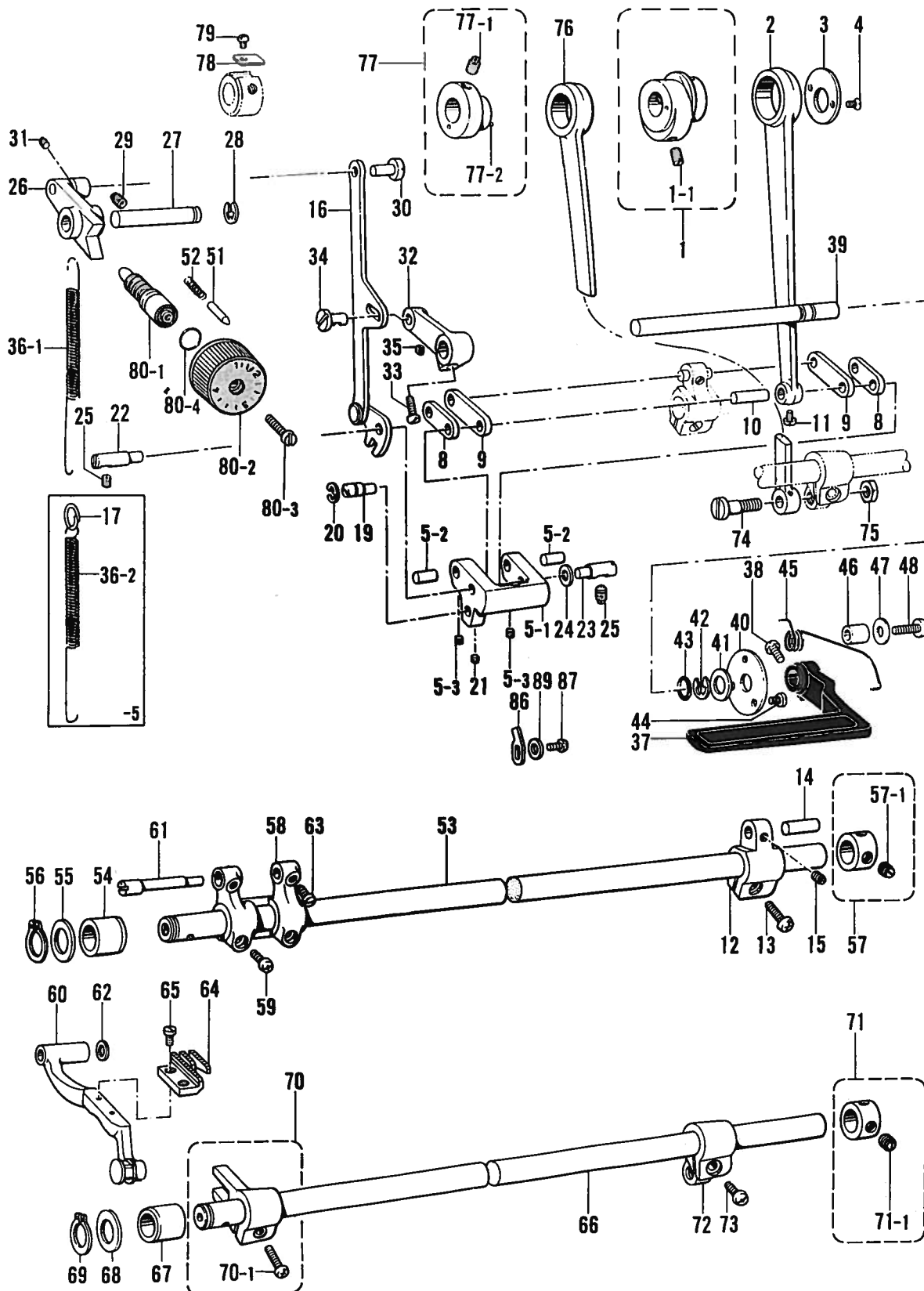

www.PromElectroAvtomat.ru

D. 送料机构/送り関係/Feed mechanism/

REE. NO.	CODE	Q'TY	ヒンメイ	NAME OF PARTS	零件名称
1	※	1	スイヘイヘンシンリンネジツキ	LEVEL FEED ECCENTRIC WHEEL	送布凸輪配件
1-1	013761410	2	トメネジ5.95クボミ	SET SCREW,(CP)SM5.95	固定螺钉 SM5.95
2	156949021	1	スイヘイオクリレンカン	LEVEL FEED CONNECTING ROD	送布连杆
3	156948021	1	レンカンオサエ	CONNECTING ROD PRESSER	送布连杆挡板
4	108960002	2	サラネジ3.57	SCREW,FLAT SM3.57	螺钉 SM3.57
5	S05898021	1	キリカエキクミ	LEVEL REGULATOR ASSY	针距调节曲柄配件
5-1	156950120	1	キリカエキ	LEVEL REGULATOR	针距调节曲柄
5-2	156951021	2	オクリリンクジク	FEED LINK STUD	曲柄短连杆销
5-3	014680622	2	アナトメネジ4.37クボミ	SET SCREW,SOCKET(CP)SM4.37	固定螺钉 SM4.37
8	156952021	1	スイヘイオクリリンククミ	FEED ROCK LINK ASSY	曲柄短连杆配件
8-1	156953021	2	スイヘイオクリリンク	FEED ROCK LINK	曲柄短连杆
9	156954021	1	スイヘイオクリウデリンククミ	FEED ROCK ARM LINK ASSY	曲柄长连杆配件
9-1	156955021	2	スイヘイオクリウデリンク	FEED ROCK ARM LINK	曲柄长连杆
10	156956021	1	リンクジク	LINK SHAFT	曲柄连杆长销
11	144458001	1	アタマツキトメネジ3.57	SET SCREW,SM3.57	螺钉 SM3.57
12	156957020	1	スイヘイオクリウデ	FEED ROCK ARM	送布曲柄
13	062711412	1	ナベコ4.76-32×14	SCREW,PAN SM4.76-32×14	螺钉 SM4.76-32×14
14	156958021	1	スイヘイオクリウデジク	FEED ROCK ARM STUD	送布曲柄销
15	151601002	1	トメネジ4.37	SET SCREW,SM4.37	螺钉 SM4.37
16	158021122	1	キリカエキレンカンクミ	FEED REGULATOR ROD ASSY	针距连杆组件
19	156966121	1	ヘンシンピン	PIN	连杆偏心销
20	048060342	1	トメワE6	RETAINING RING,E6	挡圈 E6
21	014680622	1	アナトメネジ4.37クボミ	SET SCREW,SOCKET(CP)SM4.37	固定螺钉 SM4.37
22	156967021	1	キリカエジクL	FEED REGULATOR SHAFT(L)	针距调节曲柄长轴 L
23	118734021	1	キリカエジク	FEED REGULATOR SHAFT	针距调节曲柄短轴
24	118735021	1	ザガネ	WASHER	曲柄短轴垫圈
25	151604001	2	トメネジ5.95	SET SCREW,SM5.95	螺钉 SM5.95
26	156969021	1	オクリチヨウセツキ	FEED REGULATOR	针距座
27	156970021	1	オクリチヨウセツキジク	FEED REGULATOR SHAFT	针距座铰链轴
28	048070342	1	トメワE7	RETAINING RING,E7	挡圈 E7
29	151605001	1	トメネジ5.95	SET SCREW,SM5.95	螺钉 SM5.95
30	151308121	1	レンカンジク12.5	CONNECTING STUD 12.5	针距调节连杆调整销 12.5
31	014680422	1	アナトメネジ4.37クボミ	SET SCREW,SOCKET(CP)SM4.37	固定螺钉 SM4.37
32	156971020	1	レバー	LEVER	针距调节连杆曲柄
33	062711412	1	ナベコ4.76-32×14	SCREW,PAN SM4.76-32×14	园柱头螺钉 SM4.76-32×14
34	151308121	1	レンカンジク12.5	CONNECTING STUD 12.5	针距调节连杆调整销 12.5
35	014680422	1	アナトメネジ4.37クボミ	SET SCREW,SOCKET(CP)SM4.37	固定螺钉 SM4.37
37	S32921120	1	カエシヌイレバー	REVERSE STITCHING LEVER	倒缝扳手
38	S37333001	1	ナベコ4.76-32×14	SCREW,PAN SM4.76-32×14	园柱头螺钉 SM4.76-32×14
39	S32922021	1	カエシヌイレバージク	REVERSE STITCHING LEVER SHAFT	倒缝扳手轴
40	147504221	1	カンザ	WASHER	倒缝操纵杆轴挡板
41	S35818021	1	ヒラザガネシヨウ10	WASHER,PLAIN S10	倒缝操纵杆板垫圈 S10
41	048080342	1	トメワE8	RETAINING RING,E8	挡圈 E8
43	104564001	1	Oリング	O RING	O型密封圈
44	062670712	3	ナベコ357-40×7	SCREW,PAN SM3.57-40×7	园柱头螺钉 SM3.57-40×7
46	151317021	1	カラー	COLLAR	倒缝操纵杆复位套
47	S35819021	1	ヒラザガネダイ6	WASHER,PLAIN L6	垫圈 L6
48	062782512	1	ナベコ635-28×25	SCREW,PAN SM6.35×25	园柱头螺钉 SM6.35×25
51	145502021	1	メモリーチギメピン	POSITIONING PIN	止动销
52	100328001	1	メモリーチギメピンバネ	SPRING	止动销弹簧
53	S02568121	1	スイヘイオクリジク	FEED ROCK SHAFT	送布轴
54	S31014020	1	メタル19.3	BUSH 19.3	送布轴轴套 19.3
55	156243021	1	オクリジクスラストリング	THRUST RING	送布轴轴套垫圈
56	048150142	1	トメワジクヨウC15	RETAINING RING,C15	挡圈 C15
57	183493021	1	オクリジクセットカラークミ	FEED SHAFT SET COLLAR ASSY	送布轴紧固圈组件
57-1	101706001	2	トメネジ6.35	SET SCREW,SM6.35	螺钉 SM6.35
58	156244020	1	スイヘイオクラダイウデ	FEED ROCK BRACKET ARM	牙架曲柄
59	062681212	2	ナベコ437-40×12	SCREW,PAN SM4.37-40×12	园柱头螺钉 SM4.37-40×12
60	S02569121	1	オクリダイクミ	FEED BRACKET ASSY	牙架组件

D. 送料机构/送り関係/Feed mechanism/

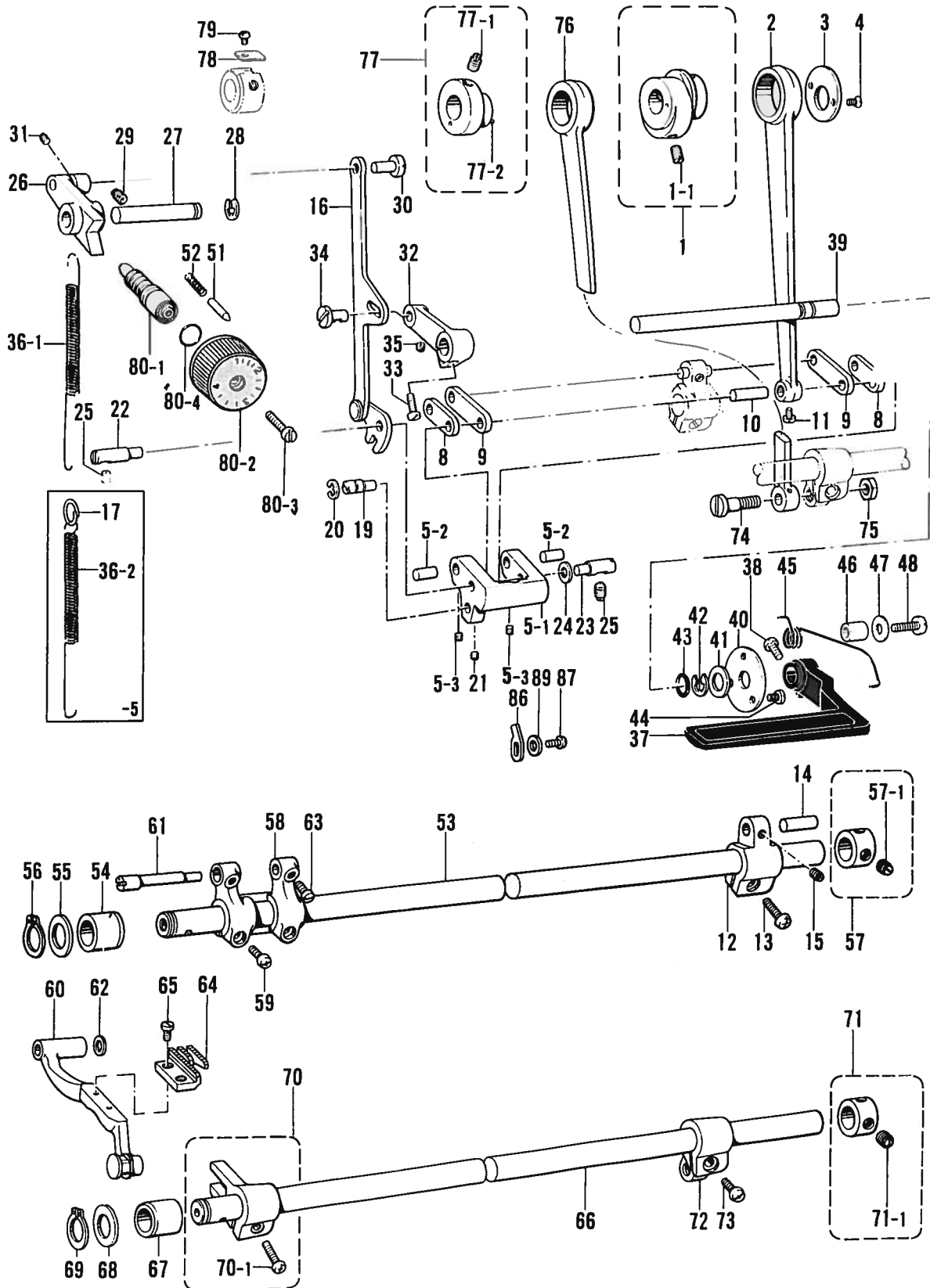

www.PromElectroAvtomat.ru

D. 送料机构/送り関係/Feed mechanism/

REE. NO.	CODE	Q'TY	ヒンメイ	NAME OF PARTS	零件名称
61	S25349021	1	オクリダイジク	FEED BRACKET SHAFT	牙架曲柄偏心轴
62	158722021	1	ザガネ4.2	WASHER 4.2	牙架垫圈 4.2
63	120990001	2	アタマツキトメネジ4.37	SET SCREW,SM4.37	螺钉 SM4.37
64	※	1	オクリバ	FEED DOG	送布牙
65	100080003	2	シメネジ3.18	SCREW,SM3.18	螺钉 SM3.18
66	S02574121	1	ジヨウゲオクリジク	FEED LIFTING ROCK SHAFT	抬牙轴
67	S31014020	1	メタル19.3	BUSH 19.3	送布轴轴套 19.3
68	156243021	1	オクリジクスラストリング	THRUST RING	送布轴轴套垫圈
69	048150142	1	トメワジクヨウC15	RETAINING RING,C15	挡圈 C15
70	180322021	1	ジヨウゲオクリウデクミ	FEED LIFTING SHAFT CRANK ASSY	抬牙叉组件
70-1	062681412	1	ナベコ437-40×14	SCREW,PAN SM4.37-40×14	园柱头螺钉 SM4.37-40×14
71	183493021	1	オクリジクセットカラークミ	FEED SHAFT SET COLLAR ASSY	抬牙轴紧圈组件
71-1	101706001	2	トメネジ6.35	SET SCREW,SM6.35	螺钉 SM6.35
72	S02575020	1	ジヨウゲオクリジクウデ	FEED LIFTING ROCK SHAFT CRANK	抬牙曲柄
73	062711212	1	ナベコ476-32×12	SCREW,PAN SM4.76-32×12	园柱头螺钉 SM4.76-32×12
74	147509021	1	ダンネジ7.14	SHOULDER SCREW,SM7.14	抬牙曲柄铰链螺钉 SM7.14
75	104689022	1	ナット7.14	NUT SM7.14	抬牙曲柄铰链螺母 SM7.14
76	118758021	1	ジヨウゲオクリレンカン	FEED LIFTING CONNECTING ROD	抬牙连杆
77	※	1	ヘンシンリンネジツキ	ECCENTRIC WHEEL WITH SCREW	抬牙凸轮配件
77-1	151604001	2	トメネジ5.95	SET SCREW,SM5.95	螺钉 SM5.95
77-2	047200642	1	スプリングピンAW2	PIN,SPRING ROLL AW2	弹簧销 AWS
78	159690021	1	オクリカムストツパー	FEED CAM STOPPER	上轴紧圈挡板
79	062670412	1	ナベコ357-40×4	SCREW,PAN SM3.57-40×4	园柱头螺钉 SM3.57-40×4
80	※	1	オクリメモリダイヤルクミ	STITCH LENGTH DIAL ASSY	针距标盘配件
80-1	S06999021	1	オクリチヨウセツネジ	ADJUST SCREW	针距调节螺杆
80-2	※	1	オクリメモリダイヤル	STITCH LENGTH DIAL	针距标盘
80-3	S21514021	1	シメネジ4.76	SCREW,SM4.76	针距标盘螺钉 SM4.76
80-4	108549001	1	Oリング	O RING	O型橡胶圈
80-5	142746022	1	メモリイタオサエ	PLATE SUPPORT	针距标盘套
<-1,-3>					
36-1	S02558201	1	ヒキバネ	SPRING	拉簧
86	S01753021	1	ストツパ	STOPPER	连杆偏心销轴位板
87	062680812	1	ナベコ437-40×8	SCREW,PAN SM4.37-40×8	园柱头螺钉 SM4.37-40×8
89	110735022	1	ザガネ	WASHER	垫圈
<-5>					
17	S04228021	1	バネカケ	SPRING HOOK	针距座拉簧环
36-2	S03818101	1	ヒキバネH	SPRING(H)	拉簧 H
<-1>					
45	S01676101	1	レバーモドシバネ	SPRING	手柄归位弹簧
<-3,-5>					
45	156974101	1	レバーモドシバネ	SPRING	手柄归位弹簧

E. 旋梭机构(竖轴下轴)/カム関係/Rotary hook mechanism/

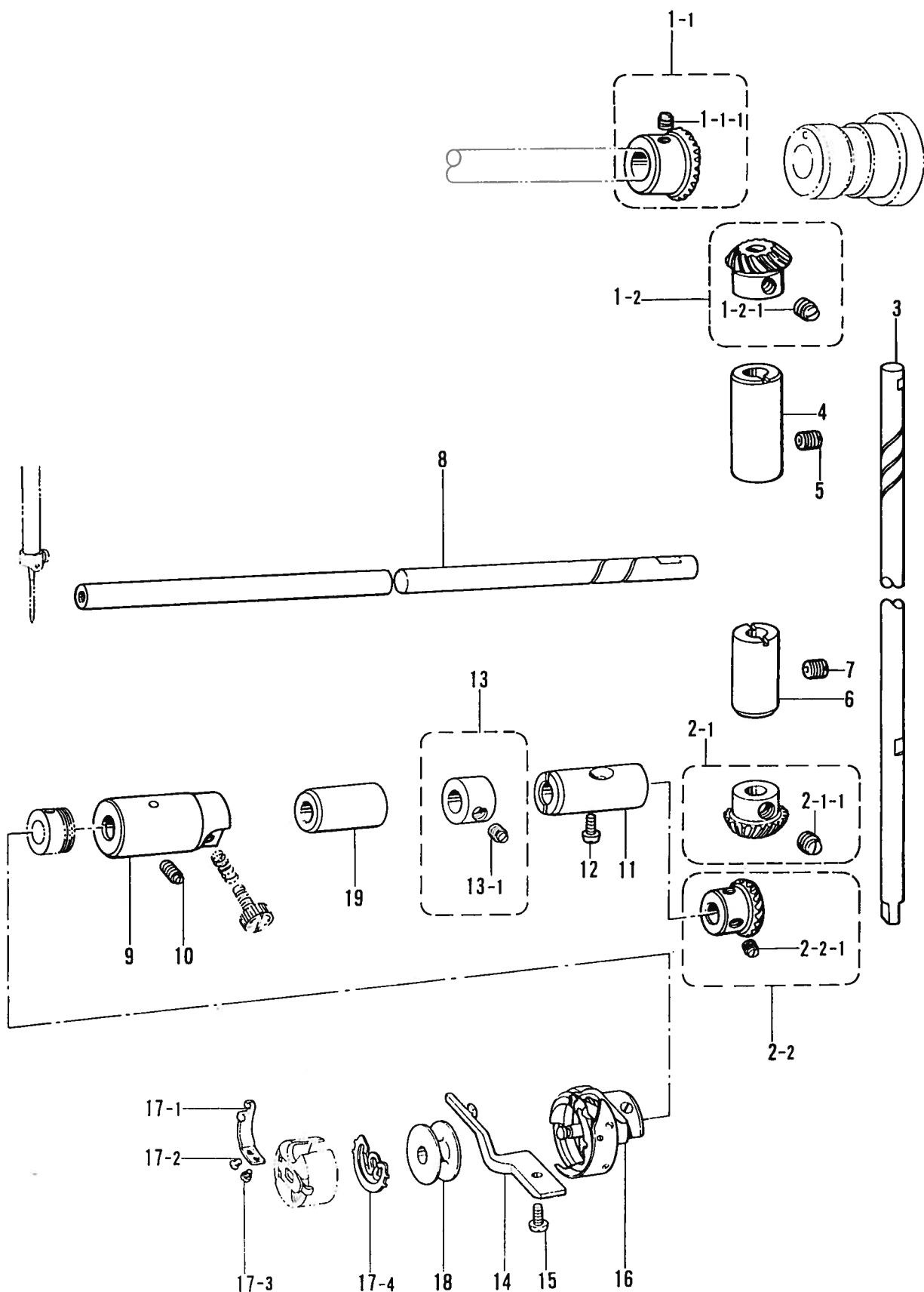

www.PromElectroAvtomat.ru

E. 旋梭机构(竖轴下轴)/カマ関係/Rotary hook mechanism/

REE. NO.	CODE	Q'TY	ヒンメイ	NAME OF PARTS	零件名称
1-1	180891001	1	ウワジクベベルギヤクミ	UPPER SHAFT BEVEL GEAR ASSY	上轴伞齿轮组件
1-1-1	100251001	2	トメネジ6.35	SET SCREW, SM6.35	螺钉 SM6.35
1-2	180892001	1	タテジクカサハグルマUクミ	VERTICAL BEVEL GEAR(U) ASSY	竖轴伞齿轮组件U
1-2-1	100251001	2	トメネジ6.35	SET SCREW, SM6.35	螺钉 SM6.35
2-1	180885001	1	タテジクカサハグルマDクミ	VERTICAL BEVEL GEAR(D) ASSY	竖轴伞齿轮组件D
2-1-1	100251001	2	トメネジ6.35	SET SCREW, SM6.35	螺钉 SM6.35
2-2	180886001	1	シタジクベベルギヤクミ	LOWER SHAFT BEVEL GEAR ASSY	下轴伞齿轮组件
2-2-1	100251001	2	トメネジ6.35	SET SCREW, SM6.35	螺钉 SM6.35
3	145516021	1	タテジク	VERTICAL SHAFT	竖轴
4	142708020	1	タテジクメタルU	VERTICAL SHAFT BUSH(U)	竖轴上轴套
5	013760610	1	トメネジ5.95クボミ	SET SCREW, (CP)SM5.95	固定螺钉 SM5.95
6	S31026020	1	タテジクメタルD	VERTICAL SHAFT BUSH(D)	竖轴下轴套
7	013761410	1	トメネジ5.95クボミ	SET SCREW, (CP)SM5.95	固定螺钉 SM5.95
8	109160021	1	シタジク	LOWER SHAFT	下轴
9	118761021	1	シタジクメタルL	LOWER SHAFT BUSH(L)	下轴左轴套
10	014680622	1	トメネジ4.37ヒラ	SET SCREW, (FT)SM4.37	螺钉 SM4.37
11	104520020	1	シタジクメタルR	LOWER SHAFT BUSH(R)	下轴右轴套
12	121007001	1	アタマツキトメネジ4.37	SET SCREW, SM4.37	螺钉 SM4.37
13	181995021	1	セツトカラークミ	SET COLLAR ASSY	下轴紧圈配件
13-1	101706001	2	トメネジ6.35	SET SCREW, SM6.35	螺钉 SM6.35
15	107407003	1	シメネジ4.37	SCREW, SM4.37	螺钉 SM4.37
17	S06573001	1	ボビンケースクミ	BOBBIN CASE ASSY	梭心套组件
17-1	183388001	1	ボビンケースチヨウシバナ	TENSION SPRING	旋梭调整簧片
17-2	183389001	1	チヨウシバナタヨウセツネジ	ADJUST SCREW	调整簧片螺钉
17-3	183390001	1	チヨウシバナトメネジ	SET SCREW	螺钉
17-4	S06594001	1	クウテンボウシバナ	BOBBIN TENSION SPRING	旋梭空转防止弹簧
19	S31027020	1	シタジクメタルM	LOWER SHAFT BUSH(M)	下轴中轴套
<-1,-3>					
14	S02602021	1	ウチカマトメ	BOBBIN CASE HOLDER	旋梭定位勾
16	159907001	1	コウソクカマB	ROTARY HOOK(B) ASSY	高速旋梭B
18	146290001	1	ボビン	BOBBIN	梭心
<-5>					
14	159324021	1	ウチカマトメ	BOBBIN CASE HOLDER	旋梭定位勾
16	S03252001	1	コウソクカマB	ROTARY HOOK(B) ASSY	高速旋梭B
18	117132001	1	ボビン	BOBBIN	梭心

F. 供油润滑机构/给油润滑關係/Lubrication/

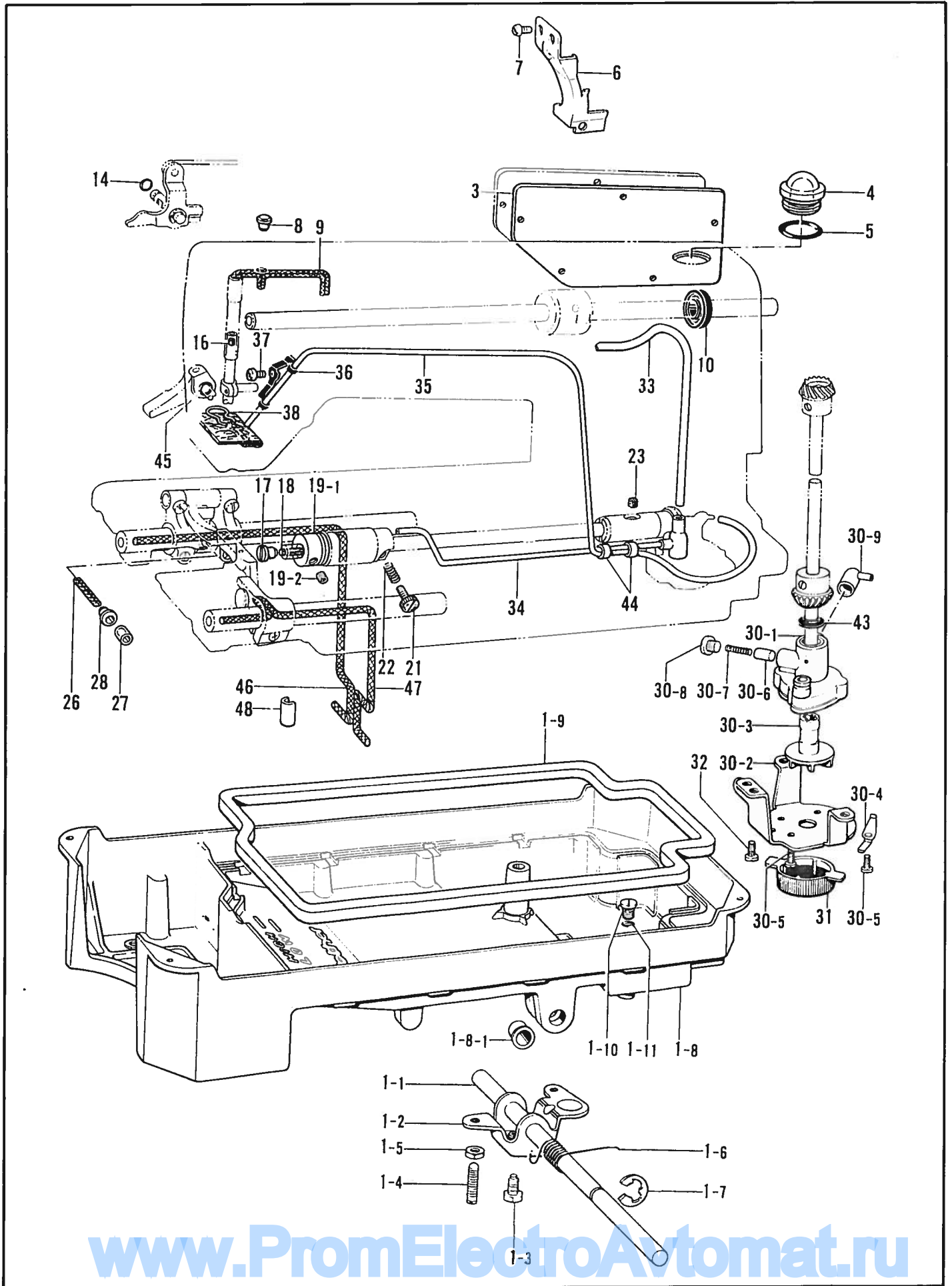

F. 供油润滑机构/給油潤滑関係/Lubrication/

REF. NO.	CODE	Q'TY	ヒンメイ	NAME OF PARTS	零件名称
1	※	1	オイルパンクミ	OIL PAN ASSY	膝控铰链轴配件(油盘组件)
1-1	146036121	1	ヒザアゲヨコシク	KNEE LIFTER SHAFT	膝控铰链轴
1-2	S09635021	1	ヒザアゲ	KNEE LIFTER	膝控限位架
1-3	146367021	1	ボルト5.95	BOLT SM5.95	膝控限位架螺钉 SM5.95
1-4	104885121	2	トメネジ5.95	SET SCREW SM5.95	膝控限位调节螺钉 SM5.95
1-5	100022024	2	ナツト5.95	NUT SM5.95	调节螺钉螺母 SM5.95
1-6	S15889021	1	ヒザアゲネジリバネ	TWIST SPRING	膝控复位簧
1-7	146293001	1	トメワE10	STOP RING E10	挡圈 E10
1-8	※	1	オイルパン	OIL PAN	油盘
1-8-1	149578020	2	ヨコシクブツシユ	BUSH	膝控铰链轴套
1-9	146040001	1	オイルパツキング	PACKING	油盘垫
1-10	140518021	1	シメネジ7.94	SCREW, SM7.94	放油螺钉 SM7.94
1-11	081007070	1	OリングP7	O RING,P7	O型圈 P7
3	S35531020	1	ガワイタパツキン	REAR COVER PACKING	后盖板垫片
4	S02606020	1	ユリヨウケイマド	OIL GAUGE WINDOW	油窗
5	081014670	1	OリングPW14	O RING,PW14	O型圈 PW14
7	062670516	2	ナベコ357-40×5	SCREW,PAN, SM3.57-40×5	园柱头螺钉 SM3.57-40×5
8	111865009	1	セン6	OIL CAP	橡皮塞
9	108804001	1	クミヒモ4×4	WICK 4×4(L=510)	油线 4×4
10	101487000	1	オイルシール	OIL SEAL	油封
14	081001670	1	OリングPW1	O RING,PW1	O型圈 PW1
17	109173101	1	オイルアナフタネジ	OIL CAP SCREW	油孔螺钉
18	106436021	1	フェルト	FELT	下轴滤油塞
19	S06684021	1	カマアブラキリクミ	OIL REJECTOR ASSY	下轴防油圈配件
19-1	S02608021	1	カマアブラキリ	OIL REJECTOR	下轴防油圈
19-2	014680422	2	アナトメネジ4.37クボミ	SET SCREW, SOCKET (CP) SM4.37	固定螺钉 SM4.37
21	145534001	1	オイルチヨウセツネジ	ADJUST SCREW	油量调节螺钉
22	116794001	1	オシバネ	SPRING	油量调节弹簧
23	107155021	1	フェルト	FELT	下轴右轴套油毡
26	S40017000	1	クミヒモ4×4	WICK 4×4(L=100)	油线 4×4
27	S40016001	1	ビニルチューブ	OIL TUBE	牙架曲柄油线套
28	141189121	1	オイルクチキヤツブ	OIL CAP	油孔塞
30	183850021	1	ポンプタイクミ	PUMP BODY ASSY	油泵配件
30-1	S32348021	1	ポンプタイ	PUMP BODY	油泵体
30-2	144869022	1	ポンプキヤク	PUMP SUPPORT	油泵体架
30-3	148849021	1	ポンプカイテンヨク	PUMP PROPELLER	油泵体轮
30-4	144874021	2	フィルターバネ	SPRING	油泵滤油盖压片
30-5	062670812	4	ナベコ3.57-40×8	SCREW,PAN SM3.57-40×8	园柱头螺钉 SM3.57-40×8
30-6	144875021	1	プランジャー	PLUNGER	柱塞
30-7	144876001	1	プランジャーバネ	PLUNGER SPRING	柱塞弹簧
30-8	112467022	1	シメネジ6.35	SCREW, SM6.35	螺钉 SM6.35
30-9	144878021	1	チューブジョイントB	TUBE JOINT (B)	回油嘴 B
31	144872121	1	ポンプフィルター	PUMP FILTER	油泵滤油盖
32	062680712	3	ナベコ437-40×7	SCREW,PAN SM4.37-40×7	园柱头螺钉 SM4.37-40×7
33	S03592020	1	オイルチューブU	OIL TUBE (U)	上输油管 U
34	S32349021	1	オイルチューブDクミ	OIL TUBE (D) ASSY	输油管组件
35	145543021	1	チューブクミ	TUBE ASSY	回油管配件
36	145547021	1	チューブホルダ	TUBE HOLDER	回油管夹板
37	062670516	1	ナベコ357-40×5	SCREW,PAN SM3.57×5	园柱头螺钉 SM3.57×5
38	145737021	1	フェルトオサエ	FELT SUPPORT	滤油毡压簧
43	146196001	1	アブラヨケ	OIL STOPPER	油封
44	146253020	2	チューブ	TUBE	油线固定带夹
45	081004070	1	OリングP4	O RING,P4	O型圈 P4
46	S08002000	1	クミヒモ	WICK (L=325)	油线
47	S08003000	1	クミヒモ	WICK (L=380)	油线
48	S08004021	1	クミヒモササエ	WICK SUPPORT	油线夹
<-1,-3>					
6	S07229121	1	テンピンオイルヨケイタ	OIL STOPPER PLATE	面板挡油板
<-5>					
6	S03253121	1	テンピンオイルヨケイタ	OIL STOPPER PLATE	面板挡油板
16	111863021	1	ハリボウセン	NEEDLE BAR CORK	针杆毡塞

G. 过线压线机构/糸通シ関係/Threading mechanism/

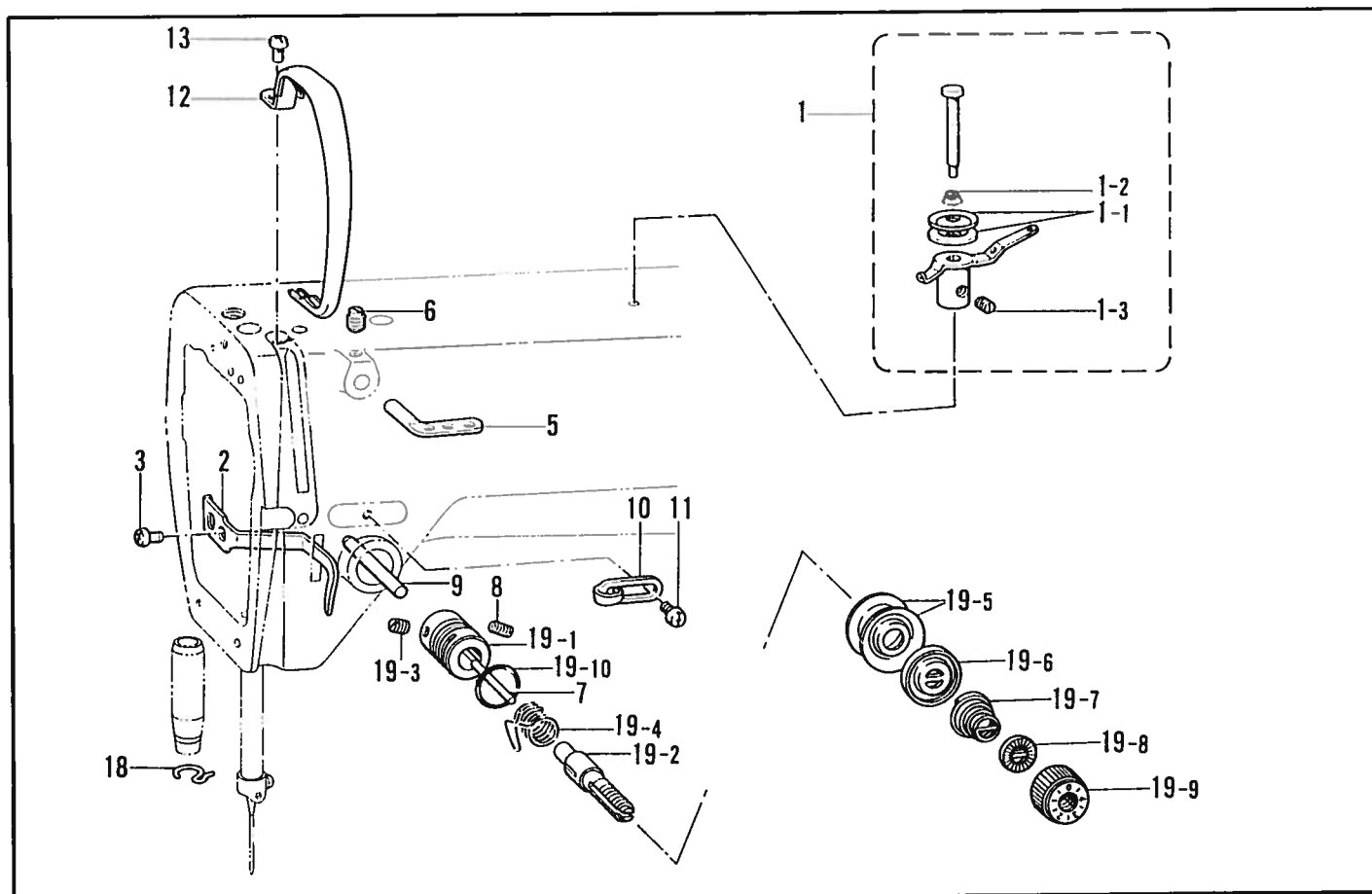

877-111-401

H. 膝控机构/膝上ゲ関係/Knee lifter mechanism

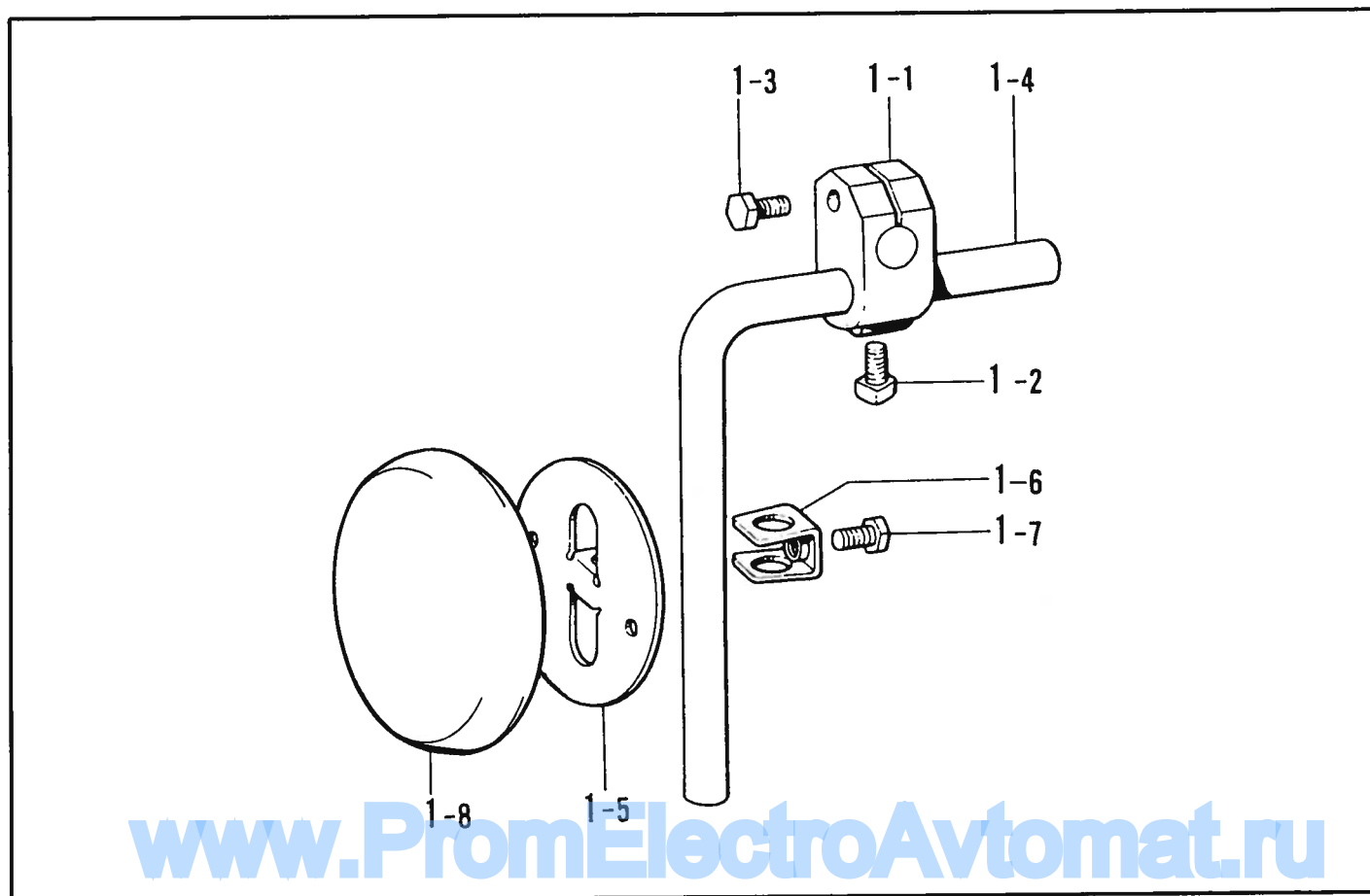

877-111-203

G. 过线压线机构/糸通シ関係/Threading mechanism/

REF. NO.	CODE	Q'TY	ヒンメイ	NAME OF PARTS	零件名称
1	144502001	1	プレテンションクミ	PRE-TENSION ASSY	小夹线组件
1-1	144504001	2	イトアンナイサラ	THREAD GUIDE DISC	小夹线板
1-2	144505000	1	イトアンナイバネ	SPRING	小夹线弹簧
1-3	102716004	1	トメネジ4.37	SET SCREW, SM4. 37	螺钉 SM4. 37
2	111469101	1	オサエボウダキイトアンナイ	THREAD GUIDE	大线勾
3	062680712	1	ナベコ437-40×7	SCREW, PAN SM4. 37-40×7	园柱头螺钉 SM4. 37-40×7
5	114931001	1	ミツメイトカケ	THREAD RETAINER	三眼线勾
6	151602002	1	トメネジ4.37	SET SCREW, SM4. 37	螺钉 SM4. 37
7	100400020	1	イトユルメピン	PIN	松线钉
8	103950003	1	トメネジ5.95	SET SCREW, SM5. 95	螺钉 SM5. 95
9	145526021	1	イトユルメボウ	TENSION RELEASE BAR	挺线钉
10	145522001	1	アームイトアンナイR	ARM THREAD GUIDE (R)	机壳线勾 R
11	S19056001	1	バインド357-40×6	SCREW, BIND SM3. 57-40×6	线勾螺钉 SM3. 57-40×6
12	S02614124	1	テンピンカバー	THREAD TAKE-UP COVER	挑线防护罩
13	062680712	1	ナベコ43-40×7	SCREW, PAN SM4. 37-40×7	园柱头螺钉 SM4. 37-40×7
18	100573001	1	ハリボウメタルDイトアンナイ	BUSH(D) THREAD GUIDE	针杆线勾
19	※	1	イトチヨウシボウダイクミ	THREAD TENSION BRACKET ASSY	夹线配件
19-1	S03254021	1	イトチヨウシボウダイ	THREAD TENSION BRACKET	夹线调节座
19-2	116922021	1	イトチヨウシボウ	TENSION STUD	夹线螺钉
19-3	100402004	1	トメネジ3.57	SET SCREW, SM3. 57	螺钉 SM3. 57
19-4	S02620001	1	イトトリバネ	SPRING	挑线簧
19-5	145446003	2	イトチヨウシサラ	TENSION DISC	夹线板
19-6	159805021	1	イトチヨウシサラオサエ	TENSION DISC PRESSER	松线板
19-7	※	1	イトチヨウシバネ	TENSION SPRING	夹线弹簧
19-8	S12441021	1	チヨウシバネウエザガネ	WASHER	压线螺母止动板
19-9	※	1	イトチヨウシナット	THREAD TENSION NUT	压线螺母
19-10	114294001	1	Oリング	O RING	O型圈

877-111-401

H. 膝控机构/膝上ゲ関係/Knee lifter mechanism

REF. NO.	CODE	Q'TY	ヒンメイ	NAME OF PARTS	零件名称
<ブラザー用/For brother>					
1	S35821021	1	ヒザアテクミ	KNEE LIFTER ASSY
1-1	146039021	1	ヒザアテツギテ	KNEE LIFTER JOINT
1-2	100463021	1	4カクボルト7.94	BOLT SM7. 94
1-3	S35820021	1	ボルト5.95×20	BOLT SM5. 95×20
1-4	104619022	1	ヒザアゲタテジク	KNEE LIFTER BAR
1-5	S34756021	1	ヒザアテ	KNEE LIFTER PLATE
1-6	114967021	1	ヒザアテストップ	KNEE LIFTER PLATE STOPPER
1-7	110087021	1	ボルト5.95	BOLT SM5. 95
1-8	S31885001	1	ヒザアテカバー	KNEE LIFTER PLATE COVER
<For TYPICAL brother / >					
1	S35821028	1	KNEE LIFTER ASSY	膝控
1-1	146039021	1	KNEE LIFTER JOINT	碰块弯杆接头
1-2	100463021	1	BOLT SM7. 94	接头螺钉 SM7. 94
1-3	S35820021	1	BOLT SM5. 95×20	弯杆接头夹紧螺钉 SM5. 95×20
1-4	104619022	1	KNEE LIFTER BAR	膝控弯杆
1-5	S34756021	1	KNEE LIFTER PLATE	膝控碰块
1-6	114967021	1	KNEE LIFTER PLATE STOPPER	碰块架
1-7	110087021	1	BOLT, SM5. 95	碰块架螺钉 SM5. 95
1-8	S31885008	1	KNEE LIFTER PLATE COVER	碰块垫

www.PromElectroAvtomat.ru

877-111-203

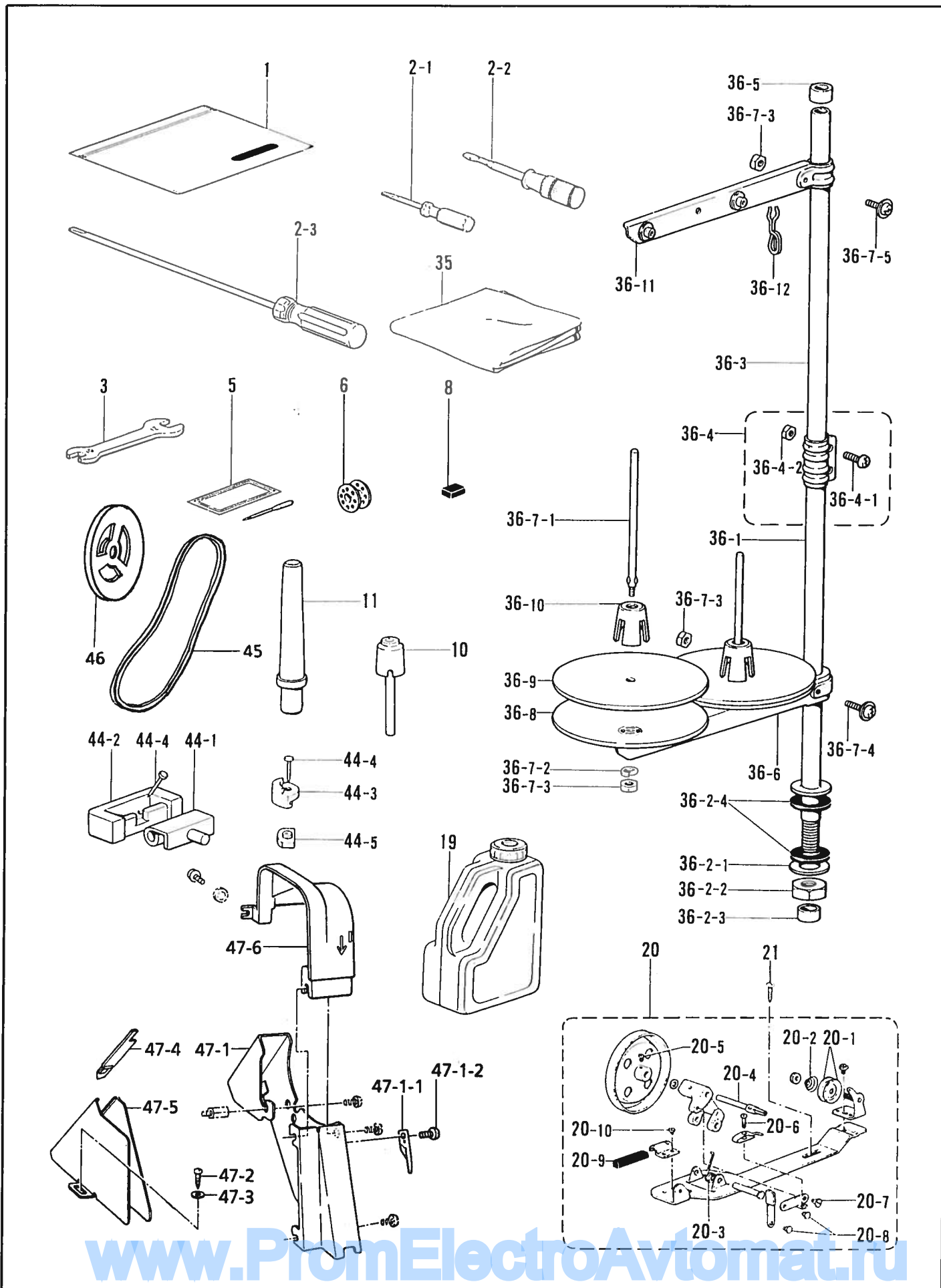

www.PromElectroAvtomat.ru

Z. 附件部分/付属品関係/Accessories/

REF. NO.	CODE	Q'TY	ヒンメイ	NAME OF PARTS	零件名称
2-1	142443021	1	ネジマワシ1.9×52	SCREW DRIVER 1.9×52	小起子 1.9×52
2-2	118837021	1	ネジマワシ3.4×70	SCREW DRIVER 3.4×70	中起子 3.4×70
2-3	S17774021	1	ネジマワシ4.7×250	SCREW DRIVER 4.7×250	大起子 4.7×250
3	100887021	1	スパナ8×9	SPANNER 8×9	双头扳手 8×9
5	※	4	ミシンハリ	NEEDLE	机针
8	112525020	1	シユウジンマグネット	MAGNET	磁块
10	S09634020	1	ヒザアゲオシボウ	KNEE LIFTER COMPLYING BAR	膝控提升顶杆
11	100477029	1	マクラ	HEAD REST	机头撑杆
19	S35822021	1	オイルタンク	OIL TANK	油箱
21	100666022	2	マルモクネジ5.5×20	WOOD SCREW,ROUND M5.5×20	下皮带罩螺钉 M5.5×20
36	S35829021	1	イトタテダイクミ2DR	COTTON STAND ASSY 2DR	线架配件 2DR
36-1	S36064021	1	コラムパイプD	COLUMN PIPE (D)	线架下撑管组件 D
36-2	S02777021	1	パイプDネジセットB	PIPE (D) SCREW SET	线架撑管螺钉组件
36-2-1	150206022	1	ヒラザガネ16	WASHER,PLAIN 16	线架下撑管垫圈 16
36-2-2	S36062021	1	6カクナツトM16	NUT,M16	线架下撑管螺母 M16
36-2-3	S35635020	1	コラムキャップ	COLUMN CAP	线架上撑管套
36-2-4	S01005020	2	イトタテゴム	RUBBER WASHER	线架下撑管橡胶垫圈
36-3	150172023	1	コラムパイプ	COLUMN PIPE	线架上撑管
36-4	S35828021	1	コラムジョイントクミ	COLUMN JOINT ASSY	撑管夹配件
36-4-1	S35826021	2	ナベコ5×14	SCREW,PAN M5×14	撑管夹螺钉 M5×14
36-4-2	S35827021	2	1シユナツト5	NUT, 1M5	撑管夹螺母 1M5
36-5	S35635020	1	コラムキャップ	COLUMN CAP	线架上撑管套
36-6	S02778022	1	スプールホルダー2	SPOOL HOLDER 2	下过线架
36-7	S35833021	1	スプールネジセット2	SPOOL SCREW SET	线轴螺钉组件
36-7-1	150179022	2	スプールジクB	SPOOL SHAFT	线轴
36-7-2	S35830021	2	バネザガネ2-5	WASHER,SPRING 2-5	线轴弹簧垫圈 2-5
36-7-3	S35827021	4	1シユナツト5	NUT, 1M5	撑管夹螺母 1M5
36-7-4	S35831021	1	+ナベザクミ5×30A	SCREW,PAN(P WASHER)M5×30A	螺钉 M5×30A
36-7-5	S35832021	1	+ナベザクミ5×14A	SCREW,PAN(P WASHER)M5×14A	螺钉 M5×14A
36-8	150180021	2	ウケザラ	SPOOL STAND BASE	线盘
36-9	150182020	2	スプールのマット	SPOOL MAT	线盘垫
36-10	126863021	2	スプールのマツション	SPOOL CUSHION	线盘压块
36-11	S02786022	1	スレッドハンガークミ2	THREAD HANGER ASSY	上过线架组件
36-12	S02747121	1	イトカケバネ	SPRING	线架过线簧
44	S35736021	1	ラバーヒンジクミ	RUBBER HINGE ASSY	机壳铰链组件
44-1	143882021	2	トウブヒンジ	HEAD HINGE	机壳铰链
44-2	143910029	2	トウブヒンジウケゴム	RUBBER CUSHION	机壳铰链套
44-3	S01302029	4	トウブシキゴム	HEAD CUSHION	机头防震垫块
44-4	109714020	8	クギ	NAIL	钉子
44-5	146004021	4	オイルパンクシヨン	OIL PAN CUSHION	机头防震钉垫

<-1.-3>

6

146290001

3 ボビン

BOBBIN

梭心

<-5>

6

117132001

3 ボビン

BOBBIN

梭心

Z. 附件部分 / 付屬品關係 / Accessories /

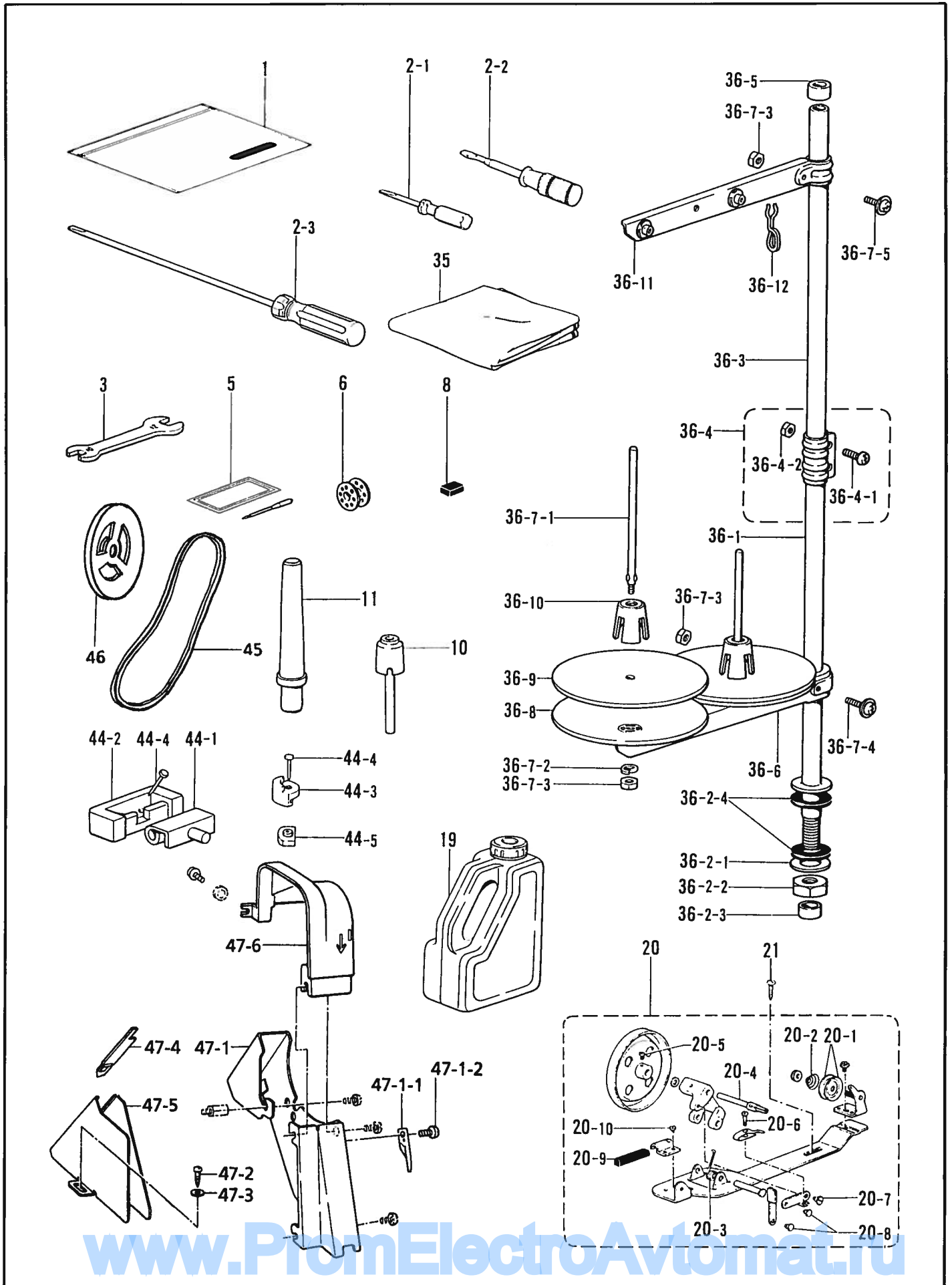

Z. 附件部分/付属品関係/Accessories/

REF.NO.	CODE	Q'TY	ヒンメイ	NAME OF PARTS	零件名称
<ブラザー用/For brother>					
1	S35730021	1	フソクヒンポリフクロ	ACCESSORY BAG	
20	S14420020	1	イトマキキクミ	BOBBIN WINDER ASSY	
20-1	145446003	2	イトチヨウシサラ	TENSION DISC	
20-2	100401021	1	イトチヨウシバネ	SPRING	
20-3	S14423021	1	イトマキジクウケカエリバネ	SPRING	
20-4	S15133021	1	イトマキジク	BOBBIN WINDER SHAFT	
20-5	151602022	1	マルヒラトメネジ4.37×5	SET SCREW, (FT)SM4.37×5	
20-6	100657021	1	シメネジ3.18	SCREW, SM3.18	
20-7	100659021	1	ダンネジ3.18	SHOULDER SCREW, SM3.18	
20-8	100661021	2	カシメピン	PIN	
20-9	100662021	1	イトマキルリマカイテンドメ	BOBBIN WINDER WHEEL STOPPER	
20-10	S01297021	1	シメネジ3.57×3.5	SCREW, SM3.57×3.5	
35	S35732021	1	トウブカバー	HEAD COVER	
47	183658228	1	ベルトカバークミA	BELT COVER SET	
47-1	S15172128	1	ベルトカバー	BELT COVER ASSY(A)	
47-1-1	S15164021	1	メス	MES	
47-1-2	062680512	1	ナベコ437-40×5	SCREW4.37-40×5	
47-1-3	100257020	1	シメネジ3.57	SCREW3.57	
47-2	100666022	2	マルモクネジ5.5×20	SCREW5.5×20	
47-3	025750132	2	ヒラザガネシヨウ5.56	PLAIN WASHER	
47-4	S37264028	1	ベルトカバーフタS	BELT COVER(D) CAP(S)	
47-5	S14428028	1	ベルトカバーD	BELT COVER(D)	
47-6	S37161028	1	ベルトカバーUC	BELT COVER(UC)	
< For TYPICAL brother/ >					
1	S35733028	1		ACCESSORY BAG	附件塑料袋
20	117963128	1		BOBBIN WINDER ASSY	绕线器组件
20-1	145446003	2		TENSION DISC	过线架夹线板
20-2	100401021	1		SPRING	过线架夹线弹簧
20-3	117969021	1		SPRING	绕线架弹簧
20-4	117970021	1		BOBBIN WINDER SHAFT	绕线轴
20-5	100366022	1		SET SCREW, (FT)SM4.37×5	绕线轮螺钉 SM4.37×5
20-6	100657021	1		SCREW, SM3.18	绕线跳板螺钉 SM3.18
20-7	100659021	1		SHOULDER SCREW, SM3.18	绕线连杆轴位螺钉 SM3.18
20-8	100661021	2		PIN	铆钉
20-9	100662021	1		BOBBIN WINDER WHEEL STOPPER	止动块
20-10	S01297021	1		SCREW, SM3.57×3.5	止动块固定勾螺钉 SM3.57×3.5
35	S35735028	1		HEAD COVER	机壳外罩
47	183658228	1		BELT COVER SET	皮带罩组件 A
47-1	S15172128	1		BELT COVER ASSY(A)	皮带罩
47-1-1	S15164021	1		MES	切刀
47-1-2	062680512	1		SCREW4.37-40×5	螺钉
47-1-3	100257020	1		SCREW3.57	螺钉 3.57
47-2	100666022	2		SCREW5.5×20	下皮带罩螺钉
47-3	025750132	2		PLAIN WASHER	下皮带罩螺钉垫圈
47-4	S37264028	1		BELT COVER(D) CAP(S)	皮带罩盖
47-5	S14428028	1		BELT COVER(D)	下皮带罩 D
47-6	S37161028	1		BELT COVER(UC)	皮带罩 UC
<-1>					
45	S36122024	1		V-BELT(M)WHITE 40~49(44)	v 皮带(M) 40~49(44)
46	281012601	1		PULLEYT 110	皮带轮 110
<-3>					
45	S36122026	1		V-BELT(M)WHITE 40~49(46)	v 皮带(M) 40~49(46)
46	281016021	1		PULLEYT 140	皮带轮 140
<-5>					
45	S36122023	1		V-BELT(M)WHITE 40~49(43)	v 皮带(M) 40~49(43)
46	281013021	1		PULLEYT 95	皮带轮 95

各种规格用零件一览表/仕様別部品一覧表/DIFFERENT PARTS LIST/

REF. NO.	品名 サブクラス 規格	ブラザー用	ブラザー用	ブラザー トルコ向け 土耳其用	ブラザー用	
		出口用 -1	出口用 -3	-3TR	出口用 -5	
A-6	ガワイタ 后盖板	S35530021	←	←	←	
A-24	メンイタクミ 面板配件	S35525021	←	←	←	
B-5	オサエバネ 压紧弹簧	147514001	141728001	←	←	
B-7	オサエクミ 压脚组件	153037221	113280121	←	150789121	
C-17	ハリボウ 针杆组件	S14811021	←	S14815021	S02811021	
C-18	ミシンハリ 机针	100265031	100265034	107415014	100265042	
C-22	ハリイタ 针板	S03884321	111859321	100266021	150792021	
D-1	スイヘイヘンシンリンネジツキ 送布凸輪配件	S02552021	←	156946021	←	
D-64	オクリバ 送布牙	S03885001	111860101	S02742001	150793001	
D-77	ヘンシンリソネジツキ 拾牙凸輪配件	S02576021	←	159708021	159706021	
D-80	オクリメモリダイヤルクミ 针距标盘配件	S31015021	←	S31018021	←	
D-80-2	オクリメモリダイヤル 针距标盘	S31016021	←	S31019021	←	
F-1	オイルバンクミ 膝控铰链轴配件(油盘组件)	183496221	←	←	←	
F-1-8	オイルパン 油盘	149580321	←	←	←	
G-19	イトチヨウシボウダイクミ 夹线配件	S31031021	←	←	S31034021	
G-19-7	イトチヨウシバネ 夹线弹簧	104525001	←	←	S04632001	
G-19-9	イトチヨウシナツト 压线螺母	S31032021	←	←	←	
Z-5	ミシンハリ 机针	100265031	100265034	107415014	100265042	

各种规格用零件一览表

REF. NO.	名称 PARTS	规格 SUB CLASS	中国用 For Typical brother -1	中国用 For Typical brother -3	中国用 For Typical brother -5		
A-6	后盖板 REAR COVER		S35625021	←	←		
A-24	面板配件 FACE PLATE ASSY		S35541021	←	←		
B-5	弹簧 SPRING		147514001	141728001	←		
B-7	压脚组件 PRESSER FOOT ASSY		153037221	113280121	150789121		
C-17	针杆组件 NEEDLE BAR		S14811021	←	S02811021		
C-18	机针 NEEDLE		100265031	100265034	100265042		
C-22	针板 NEEDLE PLATE		S03884321	111859321	150792021		
D-1	送布凸轮配件 LEVEL FEED ECCENTRIC WHEEL		S02552021	←	156946021		
D-64	送布牙 FEED DOG		S03885001	111860101	150793001		
D-77	拾牙凸轮配件 ECCENTRIC WHEEL WITH SCREW		S02576021	←	159706021		
D-80	针距标盘配件 STITCH LENGTH DIAL ASSY		S31015028	←	S31018028		
D-80-2	针距标盘 STITCH LENGTH DIAL		S31016028	←	S31019028		
F-1	油盘组件(膝控铰链轴配件) OIL PAN ASSY		183496228	←	←		
F-1-8	油盘 OIL PAN		149580328	←	←		
G-19	夹线配件 THREAD TENSION BRACKET ASSY		S31031028	←	S31034028		
G-19-7	夹线弹簧 TENSION SPRING		104525001	←	S04632001		
G-19-9	压线螺母 THREAD TENSION NUT		S31032028	←	←		
Z-5	机针 NEEDLE		100265031	100265034	100265042		

索引/INDEX/VERZEICHIS/
INDEX/INDICE

CODE	REF. NO.	Page
S00879021	B -34	2
S00909021	C -1-2	4
S01005020	Z -36-2-4	16
S01020022	B -10	2
S01297021	Z -20-10	18
	Z -20-10	18
S01302029	Z -44-3	16
S01676101	D -45	8
S01753021	D -86	8
S01998001	B -13	2
S02552021	D -1	6
S02558201	D -36-1	8
S02568121	D -53	6
S02569121	D -60	6
S02574121	D -66	8
S02575020	D -72	8
S02576021	D -77	8
S02602021	E -14	10
S02606020	F -4	12
S02608021	F -19-1	12
S02614124	G -12	14
S02617001	A -24-4	2
S02620001	G -19-4	14
S02742001	D -64	8
S02747121	Z -36-12	16
S02777021	Z -36-2	16
S02778022	Z -36-6	16
S02786022	Z -36-11	16
S02811021	C -17	4
S03252001	E -16	10
S03253121	F -6	12
S03254021	G -19-1	14
S03592020	F -33	12
S03818101	D -36-2	8
S03884321	C -22	4
S03885001	D -64	8
S04228021	D -17	8
S04632001	G -19-7	14
S05898021	D -5	6
S06325021	C -1-2	4
S06573001	E -17	10
S06594001	E -17-4	10
S06684021	F -19	12
S06999021	D -80-1	8
S07229121	F -6	12
S08002000	F -46	12
S08003000	F -47	12
S08004021	F -48	12
S09621021	A -21	2
S09634020	Z -10	16
S09635021	F -1-2	12
S12441021	G -19-8	14
S13163001	C -11-2-1	4
	C -11-1-1	4
S13385001	B -8	2
S14420020	Z -20	18
S14423021	Z -20-3	18
S14428028	Z -47-6	18
S14811021	C -17	4
S14814001	C -21	4
S14815021	C -17	4
S15133021	Z -20-4	18
S15164021	Z -47-1-1	18

CODE	REF. NO.	Page
S15172128	Z -47-1	18
S15889021	F -1-6	12
S17774021	Z -2-3	16
S19056001	G -11	14
S21514121	D -80-3	8
S25349021	D -61	8
S31006021	B -25	2
S31010021	B -23	2
S31012021	B -3	2
S31013021	B -33	2
S31014020	D -54	6
	D -67	8
S31015021	D -80	8
S31015028	D -80	8
S31016021	D -80-2	8
S31016028	D -80-2	8
S31018021	D -80	8
S31018028	D -80	8
S31019021	D -80-2	8
S31019028	D -80-2	8
S31026020	E -6	10
S31027020	E -19	10
S31031021	G -19	14
S31031028	G -19	14
S31032021	G -19-9	14
S31032028	G -19-9	14
S31034021	G -19	14
S31034028	G -19	14
S31885001	H -1-8	14
S31885008	H -1-8	14
S31952021	B -28	2
S32348021	F -30-1	12
S32921120	D -37	6
S32922021	D -39	6
S32349021	F -34	12
S33689002	C -26	4
S34287021	C -11-1	4
S34290021	C -11-2	4
S34756021	H -1-5	14
	H -1-5	14
S35525021	A -24	2
S35526021	A -24-1	2
S35529020	A -24-2	2
S35530021	A -6	2
S35531020	F -3	12
S35541021	A -24	2
S35625021	A -6	2
S35635020	Z -36-2-3	16
	Z -36-5	16
S35730021	Z -1	18
S35732021	Z -35	18
S35733028	Z -1	18
S35735028	Z -35	18
S35736021	Z -44	16
S35817021	C -15	4
S35818021	D -41	6
S35819021	D -47	6
S35820021	H -1-3	14
	H -1-3	14
S35821021	H -1	14
S35821028	H -1	14
S35822021	Z -19	16
S35826021	Z -36-4-1	16

CODE	REF. NO.	Page
S35827021	Z -36-4-2	16
	Z -36-7-3	16
S35828021	Z -36-4	16
S35829021	Z -36	16
S35830021	Z -36-7-2	16
S35831021	Z -36-7-4	16
S35832021	Z -36-7-5	16
S35833021	Z -36-7	16
S36062021	Z -36-2-2	16
S36064021	Z -36-1	16
S36122023	Z -45	18
S36122024	Z -45	18
S36122026	Z -45	18
S37161028	Z -47-6	18
S37264028	Z -47-5	18
S37333001	D -38	6
S37812021	C -1	4
S37813021	C -1	4
S37814021	C -1-1	4
	C -1-1	4
S37815021	C -2	4
S40016001	F -27	12
S40017000	F -26	12
013760610	C -5	4
	E -5	10
013761410	D -1-1	6
	E -7	10
013781012	C -12	4
014680422	D -31	6
	F -19-2	12
	D -35	6
014680622	D -5-3	6
	D -21	6
	E -10	10
014771022	C -1-7	4
025750132	Z -47-4	18
047200642	D -77-2	8
048040342	B -17	2
048060342	D -20	6
048070342	D -28	6
048080342	D -42	6
048150142	D -56	6
	D -69	8
060670612	A -24-5	2
062351216	B -26	2
062670412	D -79	8
062670516	F -37	12
	F -7	12
062670612	A -22	2
062670712	D -44	6
062670812	F -30-5	12
062671012	A -25	2
062680512	Z -47-1-2	18
062680712	F -32	12
	G -3	14
	G -13	14
062680812	D -87	8
062681012	A -7	2
062681212	D -59	6
062681412	D -70-1	8
062711212	D -73	8
062711412	D -13	6
	D -33	6

CODE	REF. NO.	Page
062782512	D -48	6
081001670	F -14	12
081004070	F -45	12
081007070	F -1-11	12
081014670	F -5	12
100022024	F -1-5	12
100032004	C -23	4
100080003	D -65	8
100251001	C -7-1	4
100251001	E -2-2-1	10
100257020	Z -47-2	18
100260001	C -16	4
100265031	C -18	4
	Z -5	16
100265034	C -18	4
	Z -5	16
100265042	C -18	4
	Z -5	16
100266021	C -22	4
100328001	D -52	6
100366022	Z -20-5	18
100400020	G -7	14
100401021	Z -20-2	18
	Z -20-2	18
100402004	G -19-3	14
100463021	H -1-2	14
	H -1-2	14
100477029	Z -11	16
100573001	G -18	14
100657021	Z -20-6	18
	Z -20-6	18
100659021	Z -20-7	18
	Z -20-7	18
100661021	Z -20-8	18
	Z -20-8	18
100662021	Z -20-9	18
	Z -20-9	18
100666022	Z -21	16
	Z -47-3	18
100887021	Z -3	16
101487000	F -10	12
101706001	D -57-1	6
	D -71-1	8
	E -13-1	10
102630021	C -20	4
102707021	B -27	2
102716004	G -1-3	14
103950003	G -8	14
104449009	A -8	2
	A -24-3	2
104450109	A -9	2
	A -23	2
104451009	A -15	2
104464001	C -1-3	4
	C -1-3	4
104520020	E -11	10
104525001	G -19-7	14
104564001	D -43	6
104619022	H -1-4	14
	H -1-4	14
104689022	D -75	8
104821009	A -11	2
104829121	A -2	2

CODE	REF. NO.	Page
104830121	A -3	2
104832009	A -10	2
104885121	F -1-4	12
106436021	F -18	12
107155021	F -23	12
107407003	E -15	10
107415014	C -18	4
107415014	Z -5	16
108520009	A -14	2
108549001	D -80-4	8
108804001	F -9	12
108960002	D -4	6
109160021	E -8	10
109173101	F -17	12
109714020	Z -44-4	16
109763022	B -11	2
110087021	H -1-7	14
	H -1-7	14
110367021	C -13	4
110735022	D -89	8
111466121	B -1	2
111469101	G -2	14
111859321	C -22	4
111860101	D -64	8
111863021	F -16	12
111865009	F -8	12
112467022	F -30-8	12
112525020	Z -8	16
113280121	B -7	2
114294001	G -19-10	14
114561021	C -24-1	4
114931001	G -5	14
114967021	H -1-6	14
	H -1-6	14
115244028	C -25	4
115244029	C -25	4
116794001	F -22	12
116922021	G -19-2	14
117132001	E -18	10
	Z -6	16
117242021	C -14	4
117963128	Z -20	18
117969021	Z -20-3	18
117970021	Z -20-4	18
118672021	A -4	2
118734021	D -23	6
118735021	D -24	6
118758021	D -76	8
118761021	E -9	10
118837021	Z -2-2	16
120990001	D -63	8
121007001	E -12	10
122771002	C -24-2	4
126863021	Z -36-10	16
140004001	C -11-1-2	4
	C -11-2-2	4
140518021	F -1-10	12
140553102	C -19	4
140704021	A -5	2
140726020	C -4	4
141189121	F -28	12
141208021	B -4	2
141728001	B -5	2

CODE	REF. NO.	Page
142274009	A -12	2
142403001	B -35	2
142443021	Z -2-1	16
142708020	E -4	10
142746022	D -80-5	8
143882021	Z -44-1	16
143910029	Z -44-2	16
144458001	D -11	6
144502001	G -1	14
144504001	G -1-1	14
144505000	G -1-2	14
144869022	F -30-2	12
144872121	F -31	12
144874021	F -30-4	12
144875021	F -30-6	12
144876001	F -30-7	12
144878021	F -30-9	12
145446003	G -19-5	14
	Z -20-1	18
	Z -20-1	18
145471029	C -25	4
145472021	B -2	2
145476021	B -20	2
145478022	B -21	2
145479022	B -22	2
145481021	B -24	2
145502021	D -51	6
145516021	E -3	10
145522001	G -10	14
145526021	G -9	14
145534001	F -21	12
145543021	F -35	12
145547021	F -36	12
145624000	C -11-2-4	4
	C -11-1-4	4
145737021	F -38	12
146004021	Z -44-5	16
146036121	F -1-1	12
146039021	H -1-1	14
	H -1-1	14
146040001	F -1-9	12
146196001	F -43	12
146253020	F -44	12
146290001	E -18	10
	Z -6	16
146293001	F -1-7	12
146327021	C -1-4	4
	C -1-4	4
146331021	C -6	4
146333021	C -1-5	4
	C -1-5	4
146367021	F -1-3	12
147326021	C -15	4
147504221	D -40	6
147509021	D -74	8
147514001	B -5	2
147777000	C -11-1-3	4
	C -11-2-3	4
148849021	F -30-3	12
149578020	F -1-8-1	12
149580321	F -1-8	12
149580328	F -1-8	12
150172023	Z -36-3	16

CODE	REF. NO.	Page
150179022	Z -36-7-1	16
150180021	Z -36-8	16
150182020	Z -36-9	16
150206022	Z -36-2-1	16
150789121	B -7	2
150792021	C -22	4
150793001	D -64	8
151308121	D -30	6
	D -34	6
151317021	D -46	6
151594001	C -21	4
151601002	D -15	6
151602002	G -6	14
	Z -20-5	18
151604001	D -25	6
	D -77-1	8
151605001	D -29	6
153037221	B -7	2
154347001	B -29	2
155488000	C -11-1-5	4
	C -11-2-5	4
156243021	D -55	6
	D -68	8
156244020	D -58	6
156641001	C -1-6	4
	C -1-6	4
156946021	D -1	6
156948021	D -3	6
156949021	D -2	6
156950120	D -5-1	6
156951021	D -5-2	6
156952021	D -8	6
156953021	D -8-1	6
156954021	D -9	6
156955021	D -9-1	6
156956021	D -10	6
156957020	D -12	6
156958021	D -14	6
156966121	D -19	6
156967021	D -22	6
156969021	D -26	6
156970021	D -27	6
156971020	D -32	6
156974101	D -45	8
158021122	D -16	6
158722021	D -62	8
158727001	C -11-1-6	4
	C -11-2-6	4
159324021	E -14	10
159690021	D -78	8
159706021	D -77	8
159708021	D -77	8
159805021	G -19-6	14
159907001	E -16	10
159998121	B -12	2
180018121	C -24	4
180322021	D -70	8
180885001	E -2-1	10
180886001	E -2-2	10
180891001	E -1-1	10
180892001	E -1-2	10
181916121	C -7	4
181995021	E -13	10

CODE	REF. NO.	Page
183388001	E -17-1	10
183389001	E -17-2	10
183390001	E -17-3	10
183493021	D -57	6
	D -71	8
183496221	F -1	12
183496228	F -1	12
183658228	Z -47	18
183850021	F -30	12