



パーツブック
PARTS BOOK
TEILEKATAROG
LIVRE DES PIECES
LIBRO DE REFERENCIA DE PIEZAS

brother®

DH4-B980-02

電子鳩目穴かがりミシン〈ジーンズ仕様〉

ELECTRONIC EYELET BUTTON HOLER 〈Jeans specification〉

ELEKTRONISCHE KNOPFLOCHNÄHMASCHINE 〈Jeans-Ausführung〉

MACHINE ÉLECTRONIQUE POUR BOUTONNIÈRES À OEILLETES
〈Spécifications pour les Jeans〉

MÁQUINA DE HACER OJALES ELECTRÓNICA 〈Especificación para Jeans〉

パーツブックご利用に際して

1. この本は、1995年3月のデータに基づいて作成されたものです。
2. 部品は予告なしに設計変更される場合があります。
3. この本はジーンズ仕様部品のみを掲載しております。
B980本機のパーツブックと合わせてご覧ください

目次

F. 押エ関係	1
L. 二重環ルーパ関係	5
Q. 糸通シ関係	5
R. 糸切り関係	7
U. 空圧関係	7
特別注文部品一覧表	9
索引	10

Notes for using this parts book

1. This book was prepared based on information available in March 1995.
2. Parts are subject to changes in design without prior notice.
3. This parts book only lists parts for Jeans specification.
Refer to this in association with the B980 standard parts book.

CONTENTS

F. Presser foot mechanism	1
L. Double chain stitch looper mechanism	5
Q. Threading mechanism	5
R. Thread trimmer mechanism ...	7
U. Air pressure mechanism	7
OPTION PARTS LIST	9
INDEX	10

Hinweise zur Verwendung dieser Teileliste

1. Dieses Buch basiert auf den Informationen vom März 1995.
2. Modelländerungen sind vorbehalten.
3. In dieser Teileliste sind nur die Teile für die Jeans-Ausführung aufgelistet.
Verwenden Sie diese Liste zusammen mit der Teileliste für die Standardausführung der B980.

INHALTSVERZEICHNIS

F. Stoffdrückerfuß	1
L. Doppelkettenstichgreifer	5
Q. Fadenführungsvorrichtung ...	5
R. Fadenabschneidevorrichtung ..	7
U. Luftdruck	7
SONDERZUBEHÖR	9
VERZEICHNIS	10

Notes sur l'utilisation de ce manuel de pièces détachées

1. Ce manuel a été fait d'après les renseignements valables au mois de Mars 1995.
2. Les pièces peuvent être sujettes à des modifications sans préavis.
3. Dans ce manuel des pièces figurent des pièces pour les spécifications pour les Jeans seulement.
Consulter ce manuel en association avec le manuel des pièces standard de la B980.

TABLE DES MATIERES

F. Mécanisme de pied presseur ...	1
L. Mécanisme du boucleur pour point de chaînette double	5
Q. Mécanisme de l'enfilage	5
R. Mécanisme de coupe-fil	7
U. Mécanisme de la pression d'air .	7
PIÈCES EN OPTION	9
INDEX	10

Notas para usar este Manual de Piezas

1. Este libro ha sido compilado basándose en los datos de que se disponía en marzo 1995.
2. Las piezas quedan sujetas a cambios de diseño sin aviso previo.
3. En este libro de piezas sólo se indican las piezas con especificaciones para Jeans.
Consultar este libro junto con el libro de piezas estándar de la B980.

INDICE

F. Mecanismo de la prensa tela ...	1
L. Mecanismo del presilladora de double cadeneta	5
Q. Mecanismo del enhebrado	5
R. Mecanismo de la cortadura de hiros	7
U. Mecanismo de la presión de aire	7
PIEZAS OPCIONALES	9
INDICE	10

F. 押工關係 / Presser foot mechanism / Stoffdrückerfuß /
 Mécanisme de pied presseur / Mecanismo de la prensa tela

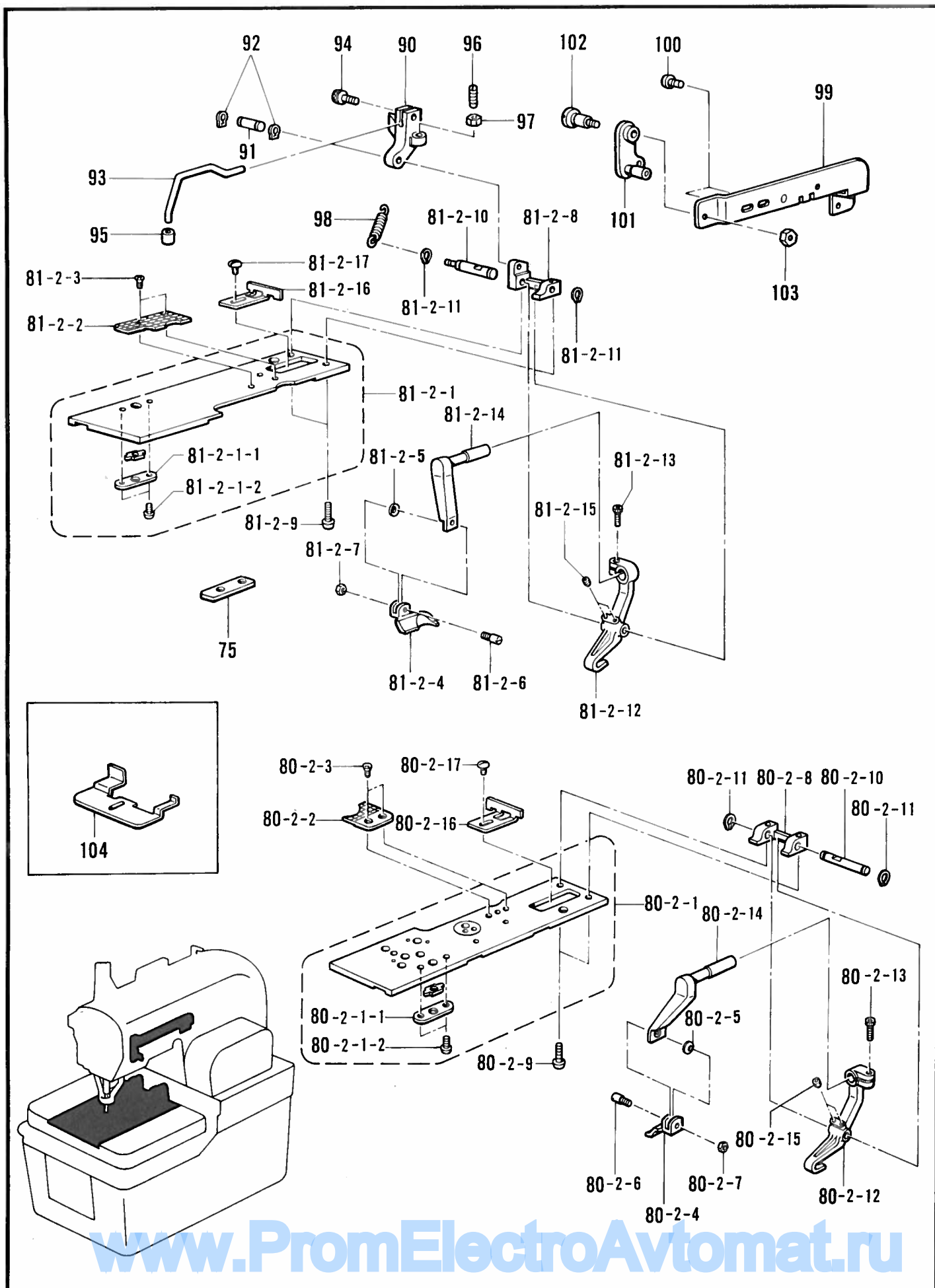

118-980-201

F. 押工関係 / Presser foot mechanism / Stoffdrückerfuß /
 Mécanisme de pied presseur / Mecanismo de la prensa tela

REF.NO.	CODE	Q'TY	ヒンメイ	NAME OF PARTS	RM
<L1 14 - 18mm>					
80-2	S37756001	1	オサエプレートJR1ソウクミ	CLOTH PRESSER PLATE (J)(R1) SET	
80-2-2	S37644001	1	ハリイタL1R	NEEDLE PLATE (L1)(R)	
80-2-4	S37754001	1	ヌノオサエR-JL1	CLOTH PRESSER (R-J)(L1)	
<L2 18 - 22mm>					
80-2	S37727001	1	オサエプレートJR2ソウクミ	CLOTH PRESSER PLATE (J)(R2) SET	
80-2-2	S37646001	1	ハリイタL2R	NEEDLE PLATE (L2)(R)	
80-2-4	S37690001	1	ヌノオサエR-JL2	CLOTH PRESSER (R-J)(L2)	
<L3 22 - 26mm>					
80-2	S37733001	1	オサエプレートJR3ソウクミ	CLOTH PRESSER PLATE (J)(R3) SET	
80-2-2	S37648001	1	ハリイタL3R	NEEDLE PLATE (L3)(R)	
80-2-4	S37692001	1	ヌノオサエR-JL3	CLOTH PRESSER (R-J)(L3)	
<L4 26 - 30mm>					
80-2	S37757001	1	オサエプレートJR4ソウクミ	CLOTH PRESSER PLATE (J)(R4) SET	
80-2-2	S37650001	1	ハリイタL4R	NEEDLE PLATE (L4)(R)	
80-2-4	S37758001	1	ヌノオサエR-JL4	CLOTH PRESSER (R-J)(L4)	
80-2-1	S37729001	1	オサエプレートJRクミ	CLOTH PRESSER PLATE (J)(R) ASSY	
80-2-1-1	S35316001	1	カクコマササエイタ	SLIDE BLOCK SUPPORT PLATE	
80-2-1-2	060020416	2	バインドM2X4	SCREW, BIND M2X4	
80-2-3	S06696004	2	サラコネジ3X6	SCREW, FLAT M3X6	
80-2-5	S35236000	1	マゲザガネ3.2	BENDING WASHER, M3.2	
80-2-6	S35235001	1	クランフササエピン	CLAMP SUPPORT PIN	
80-2-7	021300302	1	3シユナツト3	NUT, 3 M3	
80-2-8	S35238001	1	クランフジクウケ	CLAMP SHAFT HOLDER	
80-2-9	062401016	2	ナベコ4X10	SCREW, PAN M4X10	
80-2-10	S35237001	1	クランフシテンジク	CLAMP FULCRUM SHAFT	
80-2-11	048050142	2	トメワジクヨウC5	RETAINING RING, C5	
80-2-12	S35234101	1	クランフレバーR	CLAMP LEVER (R)	
80-2-13	018501236	1	アナボルト5X12	BOLT, SOCKET M5X12	
80-2-14	S37695001	1	クランフアームR-J	CLAMP ARM (R-J)	
80-2-15	014400532	2	アナクボミ4X5	SET SCREW, SOCKET (CP) M4X5	
80-2-16	S35347000	1	ヌノガイドR	CLOTH GUIDE (R)	
80-2-17	S35326001	1	シメネジM3.5	SCREW, M3.5	
<L1 14 - 18mm>					
81-2	S37731001	1	オサエプレートJL1ソウクミ	CLOTH PRESSER PLATE (J)(L1) SET	
81-2-2	S37643001	1	ハリイタL1L	NEEDLE PLATE (L1)(L)	
81-2-4	S37755001	1	ヌノオサエL-JL1	CLOTH PRESSER (L-J)(L1)	
<L2 18 - 22mm>					
81-2	S37728001	1	オサエプレートJL2ソウクミ	CLOTH PRESSER PLATE (J)(L2) SET	
81-2-2	S37645001	1	ハリイタL2L	NEEDLE PLATE (L2)(R)	
81-2-4	S37689001	1	ヌノオサエL-JL2	CLOTH PRESSER (R-J)(L2)	
<L3 22 - 26mm>					
81-2	S37735001	1	オサエプレートJL3ソウクミ	CLOTH PRESSER PLATE (J)(L3) SET	
81-2-2	S37647001	1	ハリイタL3L	NEEDLE PLATE (L3)(L)	
81-2-4	S37691001	1	ヌノオサエL-JL3	CLOTH PRESSER (L-J)(L3)	
<L4 26 - 30mm>					
81-2	S37732001	1	オサエプレートJL4ソウクミ	CLOTH PRESSER PLATE (J)(L4) SET	
81-2-2	S37649001	1	ハリイタL4L	NEEDLE PLATE (L4)(L)	
81-2-4	S37759001	1	ヌノオサエL-JL4	CLOTH PRESSER (L-J)(L4)	
81-2-1	S37730001	1	オサエプレートJLクミ	CLOTH PRESSER PLATE (J)(L) ASSY	
81-2-1-1	S35316001	1	カクコマササエイタ	SLIDE BLOCK SUPPORT PLATE	
81-2-1-2	060020416	2	バインドM2X4	SCREW, BIND M2X4	
81-2-3	S06696004	2	サラコネジ3X6	SCREW, FLAT M3X6	
81-2-5	S35236000	1	マゲザガネ3.2	BENDING WASHER, M3.2	
81-2-6	S35235001	1	クランフササエピン	CLAMP SUPPORT PIN	
81-2-7	021300302	1	3シユナツト3	NUT, 3 M3	
81-2-8	S37712001	1	クランフジクウケ	CLAMP SHAFT HOLDER	
81-2-9	062401016	2	ナベコ4X10	SCREW, PAN M4X10	
81-2-10	S37711001	1	クランフシテンジク	CLAMP FULCRUM SHAFT	
81-2-11	048050142	2	トメワジクヨウC5	RETAINING RING, C5	
81-2-12	S35233101	1	クランフレバーL	CLAMP LEVER (L)	
81-2-13	018501236	1	アナボルト5X12	BOLT, SOCKET M5X12	
81-2-14	S37694001	1	クランフアームL-J	CLAMP ARM (L-J)	
81-2-15	014400532	2	アナクボミ4X5	SET SCREW, SOCKET (CP) M4X5	
81-2-16	S35348000	1	ヌノガイドL	CLOTH GUIDE (L)	
81-2-17	S35326001	1	シメネジM3.5	SCREW, M3.5	

F. 押工関係 / Presser foot mechanism / Stoffdrückerfuß /
 Mécanisme de pied presseur / Mecanismo de la prensa tela

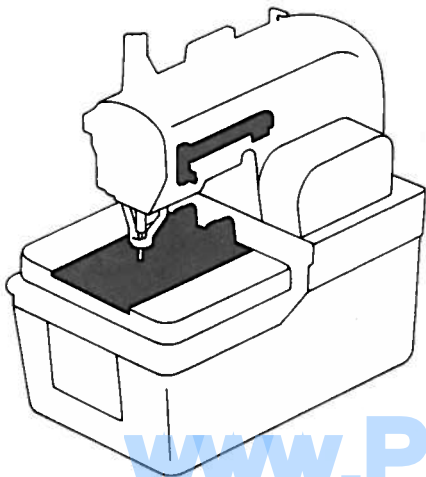
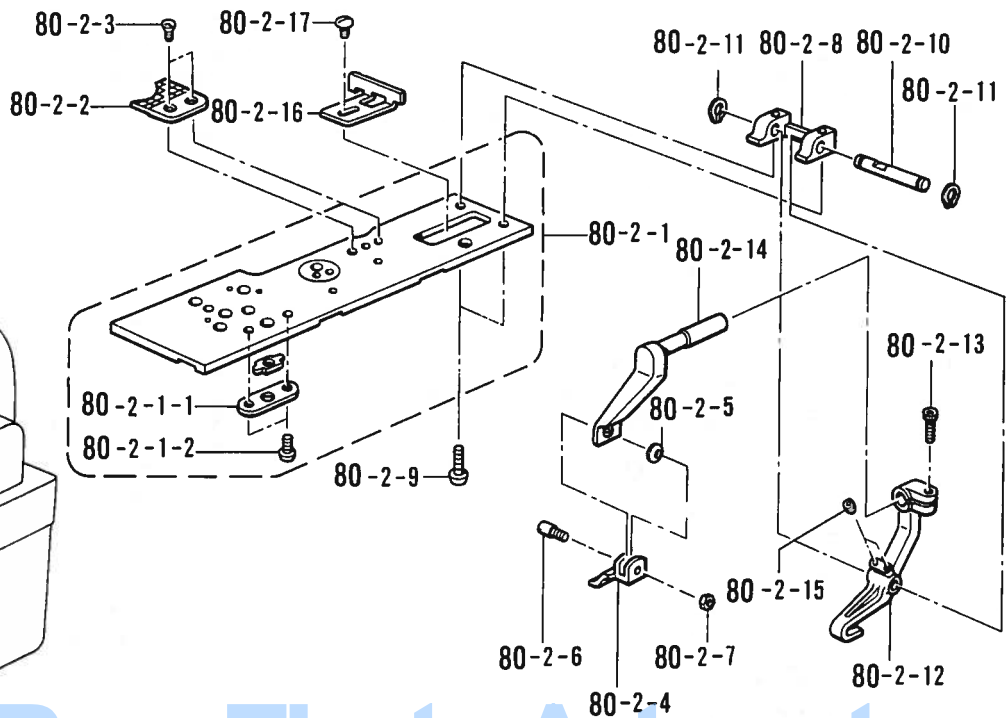
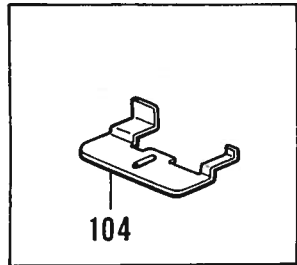
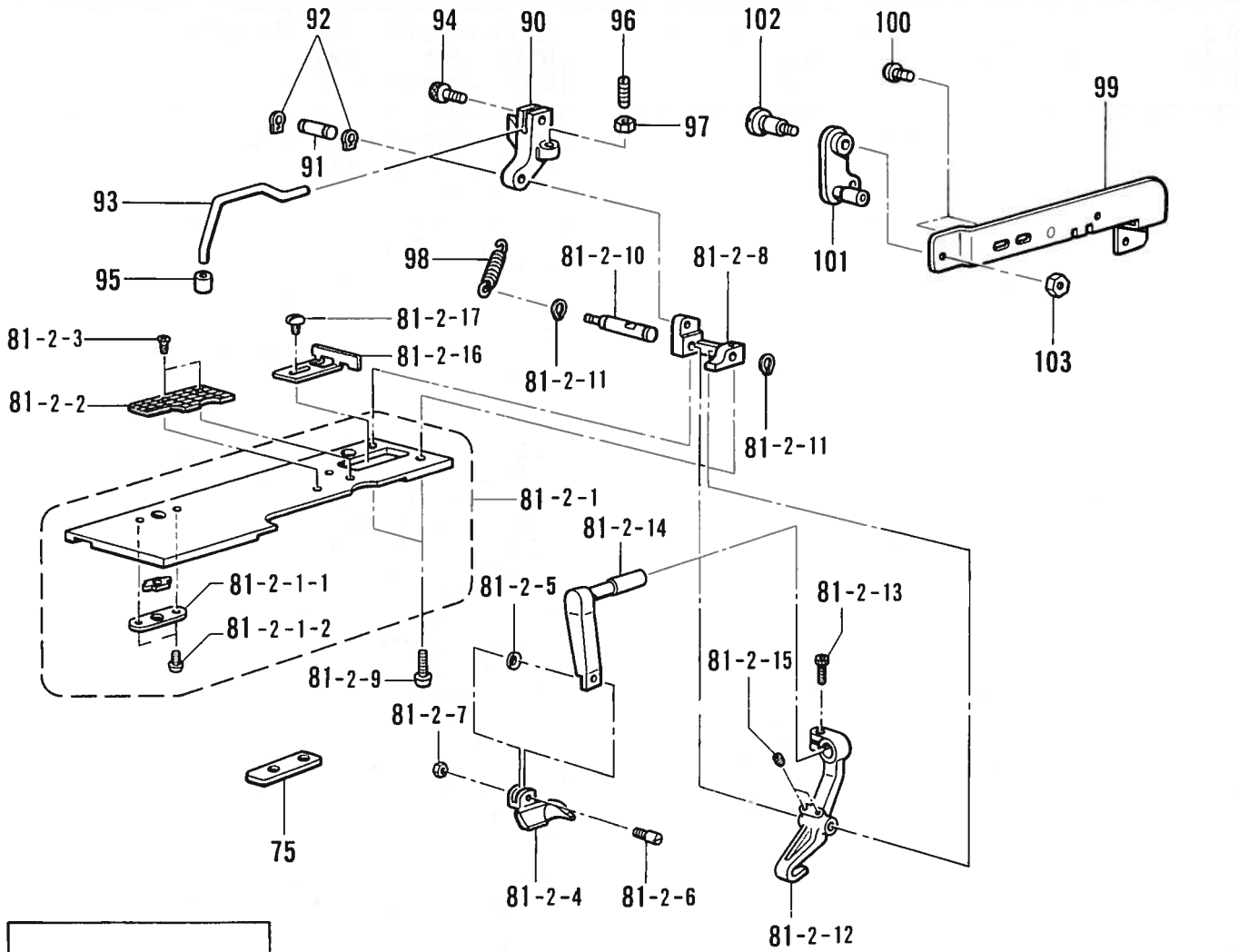

www.PromElectroAvtomat.ru

F. 押工関係 / Presser foot mechanism / Stoffdrückerfuß /
 Mécanisme de pied presseur / Mecanismo de la prensa tela

REF.NO.	CODE	Q'TY	ヒンメイ	NAME OF PARTS	RM
75	S37693001	1	プレートガイドイタC	PLATE GUIDE (C)	
90	S37714001	1	ホジヨオサエシテンダイ	SUB PRESSER FULCRUM BRACKET	
91	S37713001	1	ホジヨオサエシテンジク	SUB PRESSER FULCRUM SHAFT	
92	048050142	2	トメワジクヨウC5	RETAINING RING, C5	
93	S37718000	1	ホジヨオサエウデ	SUB PRESSER ARM	
94	018401022	1	アナボルト4X10	BOLT, SOCKET M4X10	
95	S05356000	1	ボタンオサエA	BUTTON HOLDER (A)	
96	S08808001	1	ストツフネジ	STOPPER SCREW	
97	021660102	1	ナツト1シユ3.18	NUT, 1 M3.18	
98	S37753001	1	ホジヨオサエモドシバネ	SUB PRESSER SPRING	
99	S37744001	1	Fオサエシリンダササエクミ	SUB PRESSER SYLINDER SUPPORT ASSY	
100	062400812	2	ナベコ4X8	SCREW, PAN M4X8	
101	S37717001	1	ホジヨオサエリンククミ	SUB PRESSER LINK ASSY	
102	S34922101	1	ダンネジM4	SHOULDER SCREW, M4	
103	021400202	1	2シユナツト4	NUT, 2 M4	
<オプションパーツ/OPTION PARTS>					
104	S37870000	1	ヌノガイドJ	CLOTH GUIDE (J)	

L. 二重環ルーバ関係 / Double chain stitch looper mechanism / Doppelkettenstichgreifer /
 Mécanisme du boucleur pour point de chaînette double / Mecanismo del presilladora de
 double cadeneta

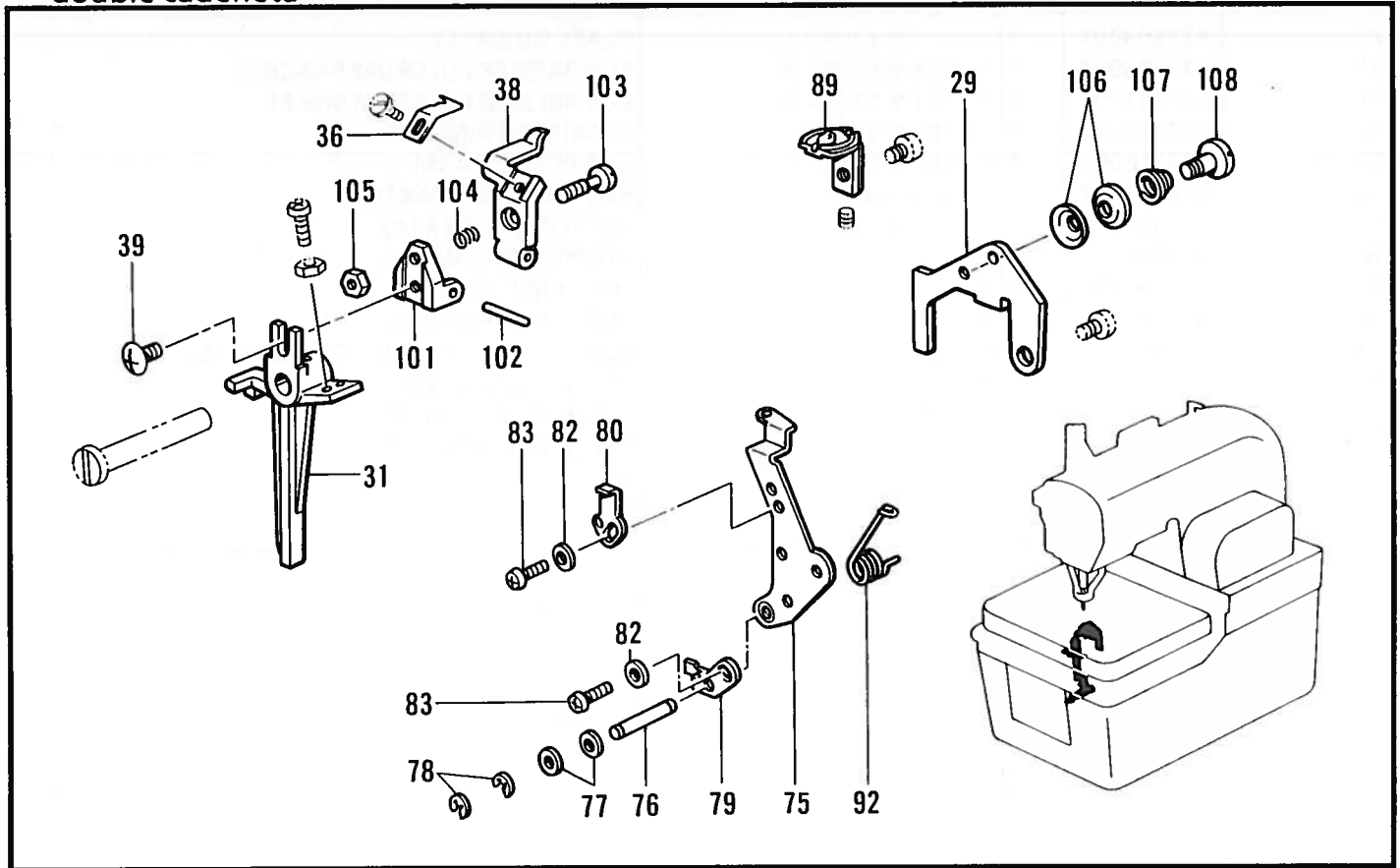

118-980-309

Q. 糸通シ関係 / Threading mechanism / Fadenführungsvorrichtung / Mécanisme de l'enfilage /
 Mecanismo del enhebrado

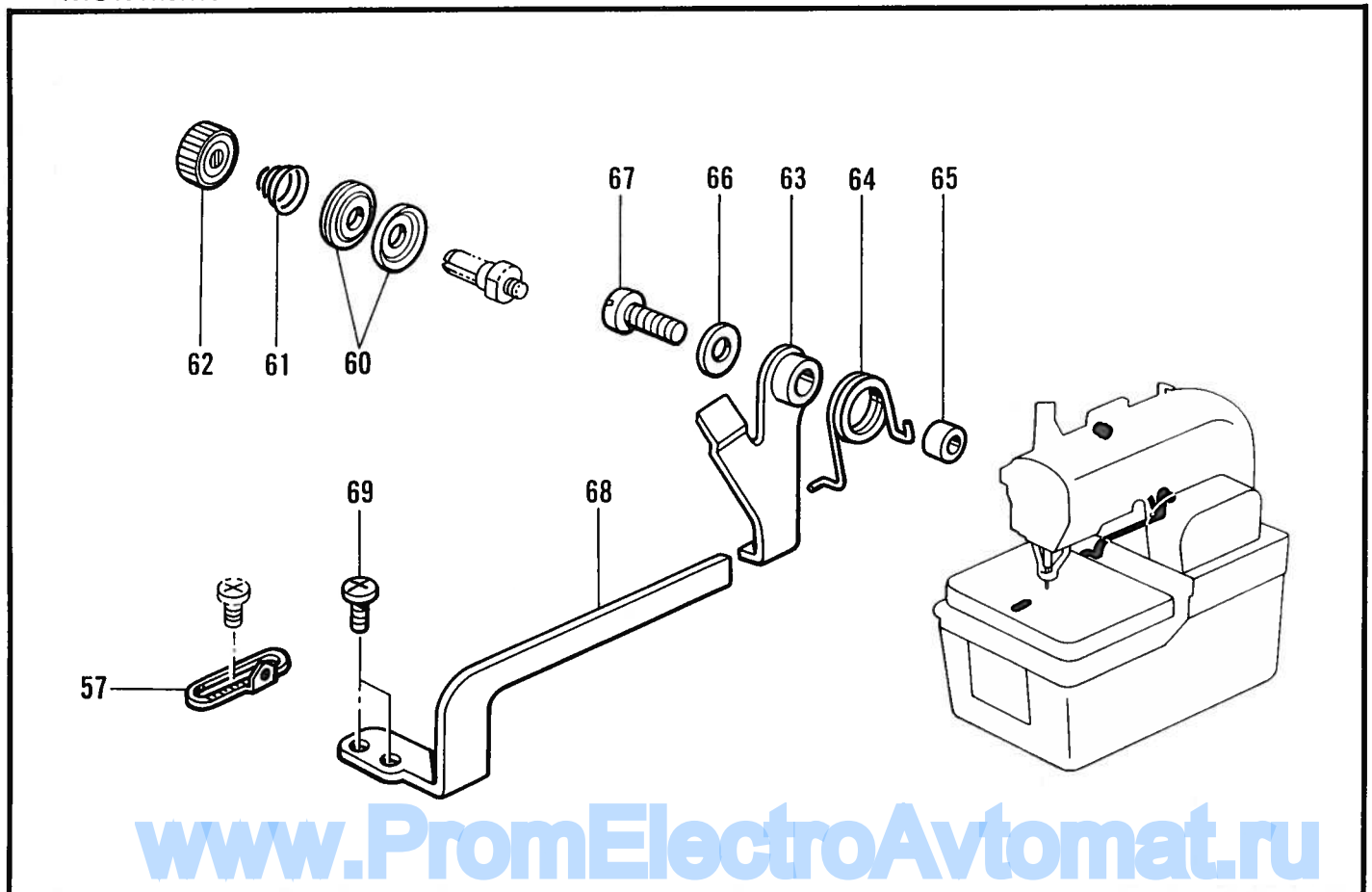

www.PromElectroAvtomat.ru

118-980-401

L. 二重環ルーパ関係 / Double chain stitch looper mechanism / Doppelkettenstichgreifer /
 Mécanisme du boucleur pour point de chaînette double / Mecanismo del presilladora de
 double cadeneta

REF.NO.	CODE	Q'TY	ヒンメイ	NAME OF PARTS	RM
29	S37696001	1	シンイトアンナイC-J	GIMP GUIDE (C-J)	
31	S37726001	1	イトキリレバードダイB	THREAD TRIMMER LEVER BRACKET (B)	
36	S37723001	1	ウワイドウハB	UPPER MOVABLE KNIFE (B)	
38	S37720001	1	シタイトオサエ	LOWER THREAD PRESSER	
39	060350616	1	バインド3.5X6	SCREW, BIND M3.5X6	
75	S35048001	1	イトユルメレバー	TENSION RELEASE LEVER	
76	S35049001	1	イトユルメレバージク	TENSION RELEASE LEVER SHAFT	
77	025680132	2	ヒラザガネシヨウ4.37	WASHER, PLAIN S 4.37	
78	048030342	2	トメワE3	RETAINING RING, E3	
79	S35050001	1	ルーパーイトユルメ	LOOPER TENSION RELEASE	
80	S35051001	1	イトユルメチョウセツイタ	TENSION RELEASE PLATE	
82	025350236	2	ヒラザガネチユウ3.5	WASHER, PLAIN M 3.5	
83	062350516	2	ナベコ3.5X5	SCREW, PAN M3.5X5	
89	S37752001	1	スロートプレート1.8-J	THROAT PLATE 1.8(J)	
92	S35057001	1	イトユルメレバーバネ	THREAD RELEASE LEVER SPRING	
101	S37721001	1	シタイトオサエダイ	LOWER THREAD PRESSER BRACKET	
102	148407001	1	ヨコアンナイミゾピンL	DOWEL PIN (L)	
103	S37724001	1	シメネジ2.38	SCREW, M2.38	
104	S37725001	1	シタイトオサエバネ	LOWER THREAD PRESSER SPRING	
105	021630102	1	ナツト1シユ2.	NUT, 1 M2	
106	S35120001	2	ハリイトアンナイサラ	THREAD GUIDE DISC	
107	S35118001	1	ハリイトチョウシバネ	TENSION SPRING	
108	S35119001	1	ハリイトダンネジ3.18	STUD SCREW 3.18	

118-980-309

Q. 糸通シ関係 / Threading mechanism / Fadenführungsvorrichtung / Mécanisme de l'enfilage /
 Mecanismo del enhebrado

REF.NO.	CODE	Q'TY	ヒンメイ	NAME OF PARTS	RM
57	S37697001	1	シンイトアンナイJ	GIMP THREAD GUIDE (J)	
60	144504001	2	イトアンナイサラ	THREAD GUIDE DISC	
61	154562001	1	フレテンションバネB	PRE-TENSION SPRING (B)	
62	155510001	1	イトチヨウシナツト	TENSION NUT	
63	S37745001	1	シンイトユルメイタ	GIMP THREAD RELEASE PLATE	
64	S37749001	1	シンイトユルメイタバネ	GIMP THREAD RELEASE PLATE SPRING	
65	147236001	1	メストリツケウデコロ	KNIFE SET ARM ROLLER	
66	025040232	1	ヒラザガネチユウ4	WASHER, PLAIN M 4	
67	062401212	1	ナベコ4X12	SCREW, PAN M4X12	
68	S37750001	1	シンイトトリアンナイJ	GIMP THREAD TAKE-UP GUIDE (J)	
69	062400812	2	ナベコ4X8	SCREW, PAN M4X8	

www.PromElectroAvtomat.ru

118-980-401

R. 糸切り関係 / Thread trimmer mechanism / Fadenabschneidevorrichtung / Mécanisme de coupe-fil / Mecanismo de la cortadura de hiros

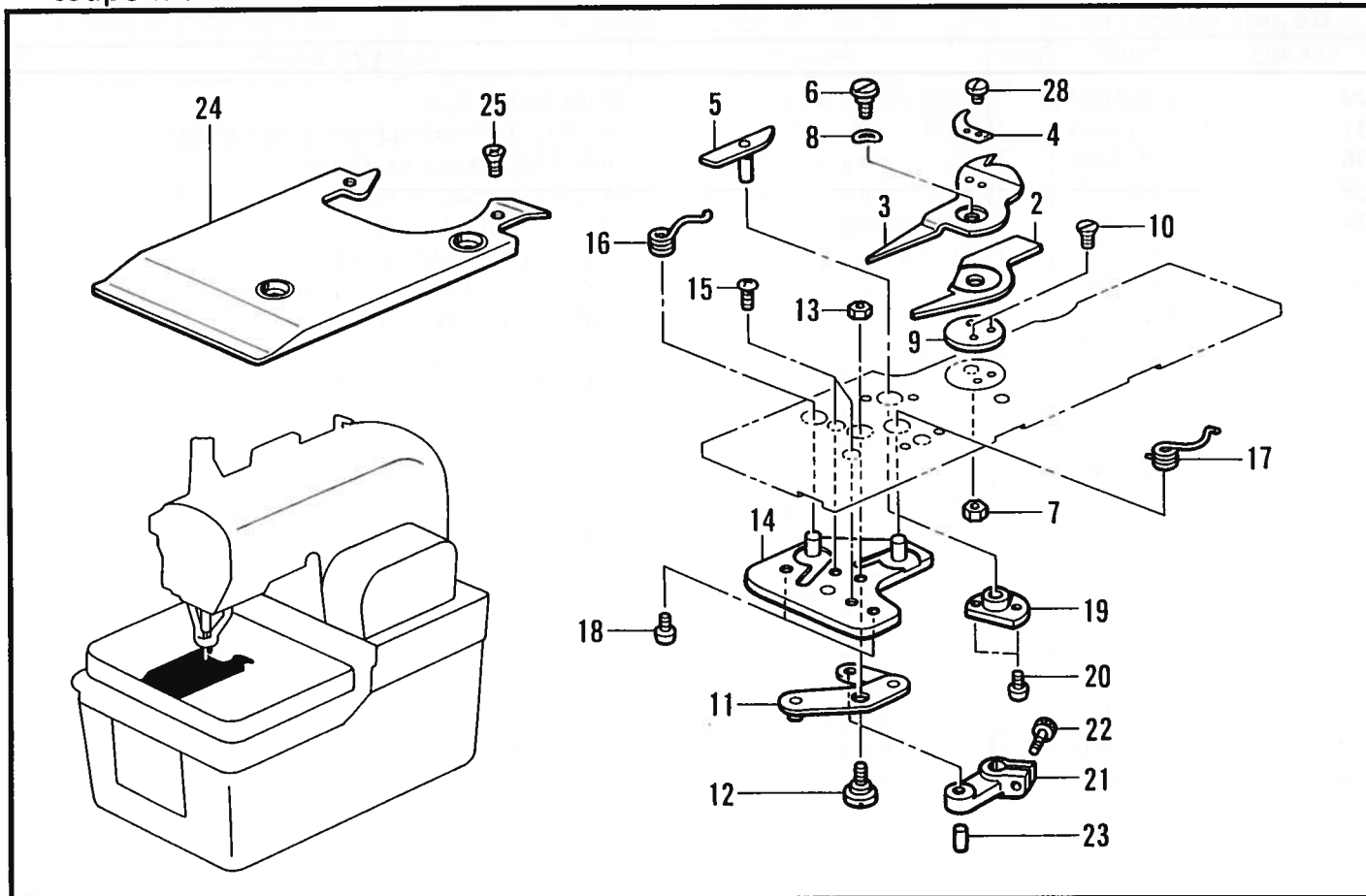

118-980-403

U. 空圧関係 / Air pressure mechanism / Luftdruck / Mécanisme de la pression d'air / Mecanismo de la presión de aire

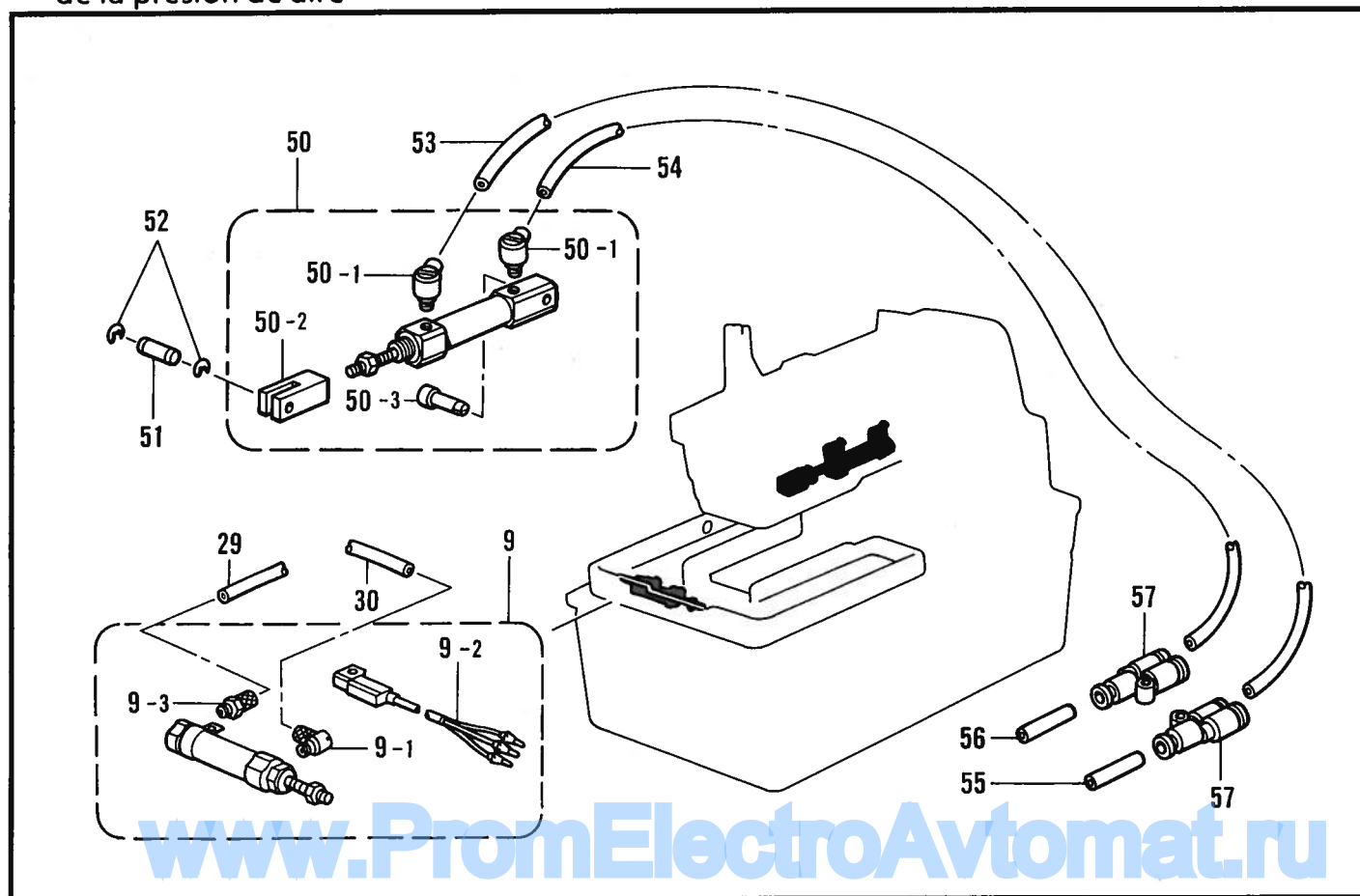

118-980-514

R. 糸切り関係 / Thread trimmer mechanism / Fadenabschneidevorrichtung / Mécanisme de coupe-fil / Mecanismo de la cortadura de hiros

REF.NO.	CODE	Q'TY	ヒンメイ	NAME OF PARTS	RM
<L1 14 - 18mm>					
2	S37673001	1	イドウハL1R	MOVABLE KNIFE (L1)(R)	
3	S37669001	1	イドウハL1L	MOVABLE KNIFE (L1)(L)	
4	S37665000	1	イトサバキL1	THREAD HANDLER L1	
5	S37661001	1	イドウハクドウカムL1	MOVABLE KNIFE DRIVING CAM (L1)	
<L2 18 - 22mm>					
2	S37674001	1	イドウハL2R	MOVABLE KNIFE (L2)(R)	
3	S37670001	1	イドウハL2L	MOVABLE KNIFE (L2)(L)	
4	S37666000	1	イトサバキL2	THREAD HANDLER L2	
5	S37662001	1	イドウハクドウカムL2	MOVABLE KNIFE DRIVING CAM (L2)	
<L3 22 - 26mm>					
2	S37675001	1	イドウハL3R	MOVABLE KNIFE (L3)(R)	
3	S37671001	1	イドウハL3L	MOVABLE KNIFE (L3)(L)	
4	S37667000	1	イトサバキL3	THREAD HANDLER L3	
5	S37663001	1	イドウハクドウカムL3	MOVABLE KNIFE DRIVING CAM (L3)	
<L4 26 - 30mm>					
2	S37676001	1	イドウハL4R	MOVABLE KNIFE (L4)(R)	
3	S37672001	1	イドウハL4L	MOVABLE KNIFE (L4)(L)	
4	S37668000	1	イトサバキL4	THREAD HANDLER L4	
5	S37664001	1	イドウハクドウカムL4	MOVABLE KNIFE DRIVING CAM (L4)	
6	S37660001	1	ダンネジM4	SHOULDER SCREW , M4	
7	021400202	1	2シユナツト4	NUT, 2 M4	
8	S37654000	1	ナミザガネ	WASHER , WAVE	
9	S37655001	1	メスササエザガネ	KNIFE SUPPORT WASHER	
10	141542001	2	サラネジ3.18	SCREW, FLAT M3.18	
11	S37656001	1	イトキリリンクレバーJクミ	THREAD TRIMMER LINK LEVER (J) ASSY	
12	S34881001	1	ダンネジM4	SHOULDER SCREW, M4	
13	021400202	1	2シユナツト4	NUT, 2 M4	
14	S37820001	1	リンクシテンプレートクミ	LINK FURCRUM PLATE ASSY	
15	062400616	2	ナベコM4X6	SCREW, PAN M4X6	
16	S37652001	1	モドシバネL	SPRING (L)	
17	S37653001	1	モドシバネR	SPRING (R)	
18	062300416	2	ナベコM3X4	SCREW, PAN M3X4	
19	S34906000	1	イトキリウデメタル	THREAD TRIMMER ARM BUSH	
20	062260612	2	ナベコ2.6X6	SCREW, PAN M2.6X6	
21	S37659001	1	イトキリレバーウデB	THREAD CUTTER LEVER ARM (B)	
22	018401022	1	アナボルト4X10	BOLT, SOCKET M4X10	
23	S37858000	1	ニードルピン4X8	NEEDLE PIN 4X8	
24	S37700001	1	オサエプレートU	PRESSER PLATE (U)	
25	004401003	2	+サラネジ4X10	SCREW, FLAT M4X10	
28	153787001	2	シメネジ2.38	SCREW, M2.38	

118-980-403

U. 空圧関係 / Air pressure mechanism / Luftdruck / Mécanisme de la pression d'air / Mecanismo de la presión de aire

REF.NO.	CODE	Q'TY	ヒンメイ	NAME OF PARTS	RM
9	S35353000	1	シリンダ16X30クミ	CYLINDER 16X30 ASSY	
9-1	S12150000	1	ホースエルボM-5HL-4	TUBE ELBOW(M-5HL-4)	
9-2	S35396000	1	シタイトキリセンサ	LOWER THREAD TRIMMER SENSOR	
9-3	S11433000	1	ホースニッフル4M5	HOSE NIPPLE (4M5)	
29	S35398000	1	エアホース4X2.5-5 (L=1440)	AIR TUBE 4X2.5-5 (L=1440)	
30	S35399000	1	エアホース4X2.5-6 (L=1490)	AIR TUBE 4X2.5-6 (L=1490)	
50	S37737001	1	シリンダ10X15Jクミ	CYLINDER	
50-1	S12150000	2	ホースエルボM-5HL-4	TUBE ELBOW (M-5HL-4)	
50-2	S35351-001	1	シリンダロッド	CYLINDER ROD	
50-3	S37866-000	1	クレビスピン	CLEVIS PIN	
51	S35305001	1	シリンダロッドピン	CYLINDER ROD PIN	
52	048030342	2	トメワE3	RETAINING RING, E3	
53	S37738000	1	エアホース4X2.5-20	AIR TUBE 4X2.5-20 (L=1350)	
54	S37739000	1	エアホース4X2.5-21	AIR TUBE 4X2.5-21 (L=1400)	
55	S37863000	1	エアホース4X2.5-3J	AIR TUBE 4X2.5-21 (L=100)	
56	S37864000	1	エアホース4X2.5-4J	AIR TUBE 4X2.5-21 (L=100)	
57	S12104000	2	ユニオンワイ4	UNION-Y 4	

118-980-514

特別注文部品一覧表 / OPTION PARTS LIST / SONDERZUBEHÖR /
PIÈCES EN OPTION / PIEZAS OPCIONALES

ミシンハリ / NEEDLE

S35133-012	ミシンハリ DOX558#80(#12)	NEEDLE DOX558#80(#12)
S35133-014	ミシンハリ DOX558#90(#14)	NEEDLE DOX558#90(#14)
S35133-016	ミシンハリ DOX558#100(#16)	NEEDLE DOX558#100(#16)
S35133-018(ジーンズ仕様標準)	ミシンハリ DOX558#110(#18)	NEEDLE DOX558#110(#18)
S35133-019	ミシンハリ DOX558#120(#19)	NEEDLE DOX558#120(#19)

ハンマー / HAMMER (ジーンズ仕様)

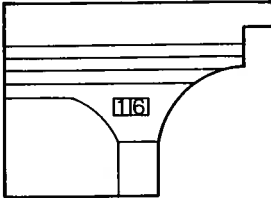
	S37701-001	ハンマー S10	HAMMER (S10)
	S37702-001	ハンマー S12	HAMMER (S12)
	S37703-001	ハンマー S14	HAMMER (S14)
	S37704-001	ハンマー S16	HAMMER (S16)
	S37705-001	ハンマー S18	HAMMER (S18)
	S37706-001	ハンマー S20	HAMMER (S20)
	S37707-001	ハンマー S22	HAMMER (S22)
	S37708-001	ハンマー S24	HAMMER (S24)
	S37709-001	ハンマー S26	HAMMER (S26)

シヨウハーネス / HARNESS

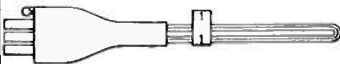
	S37869-000	シヨウハーネス L1(14~18mm)	HARNESS(L1)(14~18mm)
	S37871-000	シヨウハーネス L2(18~22mm)	HARNESS(L2)(18~22mm)
	S37872-000	シヨウハーネス L3(22~26mm)	HARNESS(L3)(22~26mm)
	S37873-000	シヨウハーネス L4(26~30mm)	HARNESS(L4)(26~30mm)

索引/INDEX/VERZEICHIS/
INDEX/INDICE

CODE	REF.NO.	Page
S05336000	F -95	4
S06696004	F -80-2-3	2
	F -81-2-3	2
S08808001	F -96	4
S11433000	U -9-3	8
S12104000	U -57	8
S12150000	U -9-1	8
	U -50-1	8
S34881001	R -12	8
S34906000	R -19	8
S34922101	F -102	4
S35048001	L -75	6
S35049001	L -76	6
S35050001	L -79	6
S35051001	L -80	6
S35057001	L -92	6
S35118001	L -107	6
S35119001	L -108	6
S35120001	L -106	6
S35233101	F -81-2-12	2
S35234101	F -80-2-12	2
S35235001	F -80-2-6	2
	F -81-2-6	2
S35236000	F -80-2-5	2
	F -81-2-5	2
S35237001	F -80-2-10	2
S35238001	F -80-2-8	2
S35305001	U -51	8
S35316001	F -80-2-1-1	2
	F -81-2-1-1	2
S35326001	F -80-2-17	2
	F -81-2-17	2
S35347000	F -80-2-16	2
S35348000	F -81-2-16	2
S35351-00	U -50-2	8
S35353000	U -9	8
S35396000	U -9-2	8
S35398000	U -29	8
S35399000	U -30	8
S37643001	F -81-2-2	2
S37644001	F -80-2-2	2
S37645001	F -81-2-2	2
S37646001	F -80-2-2	2
S37647001	F -81-2-2	2
S37648001	F -80-2-2	2
S37649001	F -81-2-2	2
S37650001	F -80-2-2	2
S37652001	R -16	8
S37653001	R -17	8
S37654000	R -8	8
S37655001	R -9	8
S37656001	R -11	8
S37659001	R -21	8
S37660001	R -6	8
S37661001	R -5	8
S37662001	R -5	8
S37663001	R -5	8
S37664001	R -5	8
S37665000	R -4	8
S37666000	R -4	8
S37667000	R -4	8
S37668000	R -4	8
S37669001	R -3	8

CODE	REF.NO.	Page
S37670001	R -3	8
S37671001	R -3	8
S37672001	R -3	8
S37673001	R -2	8
S37674001	R -2	8
S37675001	R -2	8
S37676001	R -2	8
S37689001	F -81-2-4	2
S37690001	F -80-2-4	2
S37691001	F -81-2-4	2
S37692001	F -80-2-4	2
S37693001	F -75	4
S37694001	F -81-2-14	2
S37695001	F -80-2-14	2
S37696001	L -29	6
S37697001	Q -57	6
S37700001	R -24	8
S37711001	F -81-2-10	2
S37712001	F -81-2-8	2
S37713001	F -91	4
S37714001	F -90	4
S37717001	F -101	4
S37718000	F -93	4
S37720001	L -38	6
S37721001	L -101	6
S37723001	L -36	6
S37724001	L -103	6
S37725001	L -104	6
S37726001	L -31	6
S37727001	F -80-2	2
S37728001	F -81-2	2
S37729001	F -80-2-1	2
S37730001	F -81-2-1	2
S37731001	F -81-2	2
S37732001	F -81-2	2
S37733001	F -80-2	2
S37735001	F -81-2	2
S37737001	U -50	8
S37738000	U -53	8
S37739000	U -54	8
S37744001	F -99	4
S37745001	Q -63	6
S37749001	Q -64	6
S37750001	Q -68	6
S37752001	L -89	6
S37753001	F -98	4
S37754001	F -80-2-4	2
S37755001	F -81-2-4	2
S37756001	F -80-2	2
S37757001	F -80-2	2
S37758001	F -80-2-4	2
S37759001	F -81-2-4	2
S37820001	R -14	8
S37858000	R -23	8
S37863000	U -55	8
S37864000	U -56	8
S37866-00	U -50-3	8
S37870000	F -104	4
004401003	R -25	8
014400532	F -80-2-15	2
	F -81-2-15	2
018401022	F -94	4
	R -22	8

CODE	REF.NO.	Page
018501236	F -80-2-13	2
	F -81-2-13	2
021300302	F -80-2-7	2
	F -81-2-7	2
021400202	F -103	4
	R -7	8
	R -13	8
021630102	L -105	6
021660102	F -97	4
025040232	Q -66	6
025350236	L -82	6
025680132	L -77	6
048030342	L -78	6
	U -52	8
048050142	F -80-2-11	2
	F -81-2-11	2
	F -92	4
060020416	F -80-2-1-2	2
	F -81-2-1-2	2
062260612	R -20	8
062300416	R -18	8
062350516	L -83	6
060350616	L -39	6
062400616	R -15	8
062400812	F -100	4
	Q -69	6
062401016	F -80-2-9	2
	F -81-2-9	2
062401212	Q -67	6
141542001	R -10	8
144504001	Q -60	6
147236001	Q -65	6
148407001	L -102	6
153787001	R -28	8
154562001	Q -61	6
155510001	Q -62	6

ПРОМЭЛЕКТРОАВТОМАТ

№ п/п	Наименование	Единица измерения	Количество	Стоимость	Итого
1					
2					
3					
4					
5					

вертолет



brother.

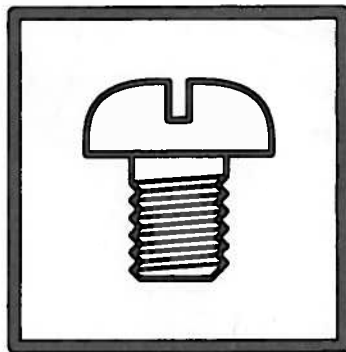

パーツブック
PARTS BOOK
TEILEKATALOG
LIVRE DES PIECES
LIBRO DE REFERENCIA DE PIEZAS

ブラザー工業株式会社

BROTHER INDUSTRIES, LTD.

〒467 名古屋市瑞穂区河岸1丁目1番1号 TEL(052)824-2392(代)

Printed in Japan/Gedruckt in Japan /Imprimé au Japon/Impreso en Japon

118-980
S96980-011
1995. 06.H ①

www.PromElectroAvtome.ru