

# DT4-B261-0M2-M

パーツブック

PARTS BOOK

TEILEKATALOG

LIVRE DES PIECES

LIBRO DE REFERENCIA DE PIEZAS

箱型二重環縫ミシン〈向う当布付け用〉

FLAT BED DOUBLE CHAIN STITCHER  
< FOR ATTACHING POCKET FACING >

FLACHBETT-DOPPELKETTENSTICHMASCHINE  
< ANNÄHEN VON TASCHENBESÄTZEN >

MACHINE POINT DE CHAINETTE A PLATEAU - 1 AIGUILLE AVEC COUPE-FIL  
< POUR LA FIXATION DES REVERS DE POCHE >

RECUBRIDORA PLANA, UNA AGUJA CON CORTAHILOS  
< PARA COLOCACION DE FORRO EXTERIOR DE BOLSILLOS >

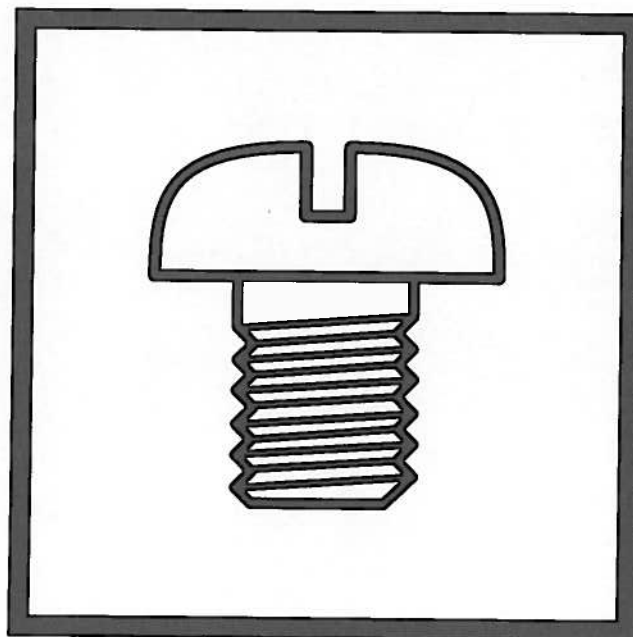

---

brother.

# DT4-B561-0M2-M

LIBRO DE REFERENCIA DE PIEZAS  
LIVRE DES PIÈCES  
TEIKENATAWA  
PARTS BOOK  
16-7733

FOR THE EXTERIOR OF THE TORO

FOR ATTACHING TO THE TORO

FOR THE EXTERIOR OF THE TORO

FOR THE EXTERIOR OF THE TORO

FOR THE EXTERIOR OF THE TORO



## パーツブックご利用に際して

1. この本は、1998年9月のデータに基づいて作成されたものです。
2. 部品は予告なしに設計変更される場合があります。
3. 組単位で補給する部品は、[ ]破線で示しております。

## 目 次

A. 主体関係 .....	1
B. 上軸・針棒関係 .....	5
C. 押エ関係 .....	7
D. 送り関係 .....	9
E. 下軸関係 .....	13
F. ルーパー関係 .....	15
G. スプレダー関係 .....	17
H. 給油潤滑関係 .....	19
J. 糸調子関係 .....	23
Z. 付属品関係 .....	27
索引 .....	31

# Notes for using this parts book      Hinweise zur Verwendung dieser Teileliste

1. This book was prepared based on information available in September 1998.
  2. Parts are subject to changes in design without prior notice.
  3. Parts supplied as complete assemblies are circled by a dotted line [ ] .
1. Dieses Buch basiert auf den Informationen vom September 1998.
  2. Modelländerungen sind vorbehalten.
  3. Die Teile, die als kompletter Satz geliefert werden, sind mit einer [ ] gestrichelten Linie umrandet.

## CONTENTS

## INHALTSVERZEICHNIS

A. Machine body .....	1
B. Upper shaft and needle bar mechanism .....	5
C. Presser foot mechanism .....	7
D. Feed mechanism .....	9
E. Lower shaft mechanism .....	13
F. Looper mechanism .....	15
G. Spreader mechanism .....	17
H. Lubrication .....	19
J. Thread tension .....	23
Z. Accessories .....	27
INDEX .....	31

A. Maschinengehäuse .....	1
B. Obere Welle und Nadelstangenvorrichtung .....	5
C. Stoffdrückerfuß .....	7
D. Transportvorrichtung .....	9
E. Untere Welle .....	13
F. Greifer .....	15
G. Spreizvorrichtung .....	17
H. Schmierung .....	19
J. Fadenspannung .....	23
Z. Zubehör .....	27
VERZEICHNIS .....	31

## Notes sur l'utilisation de ce manuel de pièces détachées

1. Ce manuel a été fait d'après les renseignements valables au mois de Septembre 1998.
2. Les pièces peuvent être sujettes à des modifications sans préavis.
3. Les pièces fournies en tant qu'assemblages complets sont encadrées avec un trait pointillé [ ] .

## TABLE DES MATIERES

A. Corps de la machine .....	1
B. Mécanisme de arbre supérieur et barra à aiguille .....	5
C. Mécanisme de pied presseur ...	7
D. Mécanisme de l'entraînement .	9
E. Mécanisme de l'arbre inférieur	13
F. Mécanisme des griffes .....	15
G. Mécanisme de l'étendeur .....	17
H. Lubrification .....	19
J. Tension du fil .....	23
Z. Accessoires .....	27
INDEX .....	31

## Notas para usar este Manual de Piezas

1. Este libro ha sido compilado basándose en los datos de que se disponía en septiembre 1998.
2. Las piezas quedan sujetas a cambios de diseño sin aviso previo.
3. Las piezas suministradas como conjuntos completos se enmarcan con una línea punteada [ ] .

## INDICE

A. Cuerpo de la máquina .....	1
B. Mecanismo del eje superior y la barra de aguja .....	5
C. Mecanismo de la prensa tela ...	7
D. Mecanismo de la alimentación .	9
E. Mecanismo del eje inferior ....	13
F. Mecanismo del presilladora ...	15
G. Mecanismo extendedor .....	17
H. Lubricación .....	19
J. Tensión del hilo .....	23
Z. Accesorios .....	27
INDICE .....	31

A . 主体関係 / Machine body / Maschinengehäuse / Corps de la machine / Cuerpo de la máquina

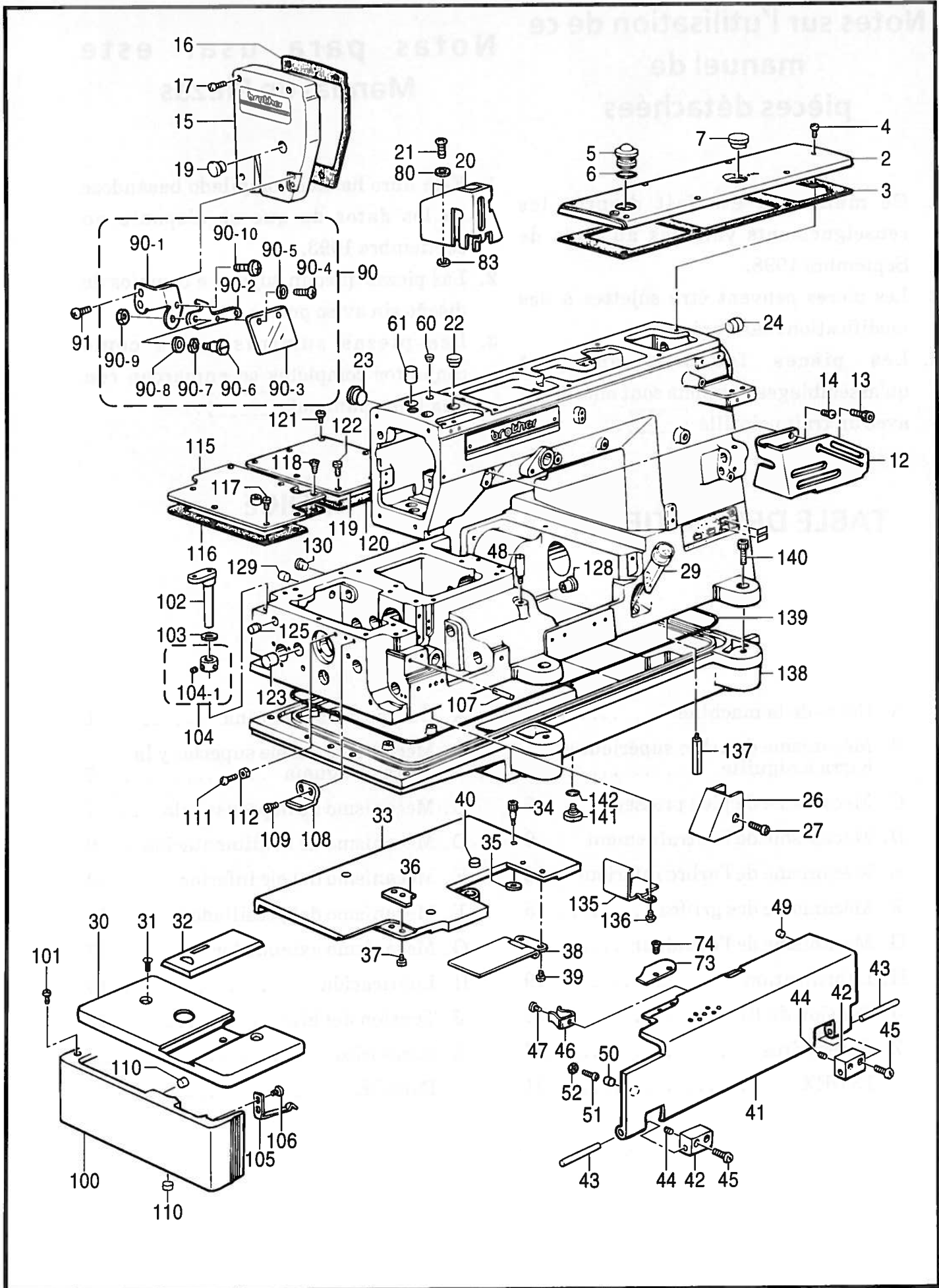

A. 主体関係 / Machine body / Maschinengehäuse / Corps de la machine / Cuerpo de la máquina

REF.NO.	CODE	Q'TY	ヒンメイ	NAME OF PARTS	RM
2	S08627001	1	ウフフタ	TOP COVER	
3	S08628000	1	ウフフタハツキン	TOP COVER PACKING	
4	062681012	7	ナベコ437-40X10	SCREW, PAN SM4.37-40X10	
5	S02606000	1	ユリヨウケイマド	OIL GAUGE WINDOW	
6	081014670	1	OリングPW14	O RING, PW14	
7	159150009	1	ゴムセン20.5	RUBBER CAP, 20.5	
12	S40532101	1	ハリイトクリカパー	NEEDLE THREAD TAKE-UP COVER	
13	018060822	1	アナボルト6X8	BOLT, SOCKET M6X8	
14	S10774001	1	ナベコ437-40X7	SCREW, PAN M4.37-40X7	
15	S28810051	1	メンイタ	FACE PLATE	
16	S08631000	1	メンイタハツキン	FACE PLATE PACKING	
17	062681612	4	ナベコ437-40X16	SCREW, PAN SM4.37-40X16	
19	117934009	1	ゴムセン13.5	RUBBER CAP, 13.5	
20	S28809201	1	ハリボウテンピンカバー	NEEDLE BAR TAKE-UP COVER	
21	062681012	2	ナベコ437-40X10	SCREW, PAN SM4.37-40X10	
22	104449009	1	ゴムセン15.5	RUBBER CAP, 15.5	
23	108520009	1	ゴムセン19.8	RUBBER CAP, 19.8	
24	S00313009	1	ゴムセン16.8	RUBBER CAP, 16.8	
26	S08633101	1	シタイトカバー	BOBBIN THREAD COVER	
27	062680812	1	ナベコ437-40X8	SCREW, PAN SM4.37-40X8	
29	148084001	1	オイルゲージマド	OIL GAUGE WINDOW	
30	S40960051	1	クロスプレートL	CLOTH PLATE (L)	
31	100032004	2	サラネジ4.37	SCREW, FLAT SM4.37	
32	S40961001	1	スベリイタ	SLIDE PLATE	
33	S47211001	1	クロスプレートR	CLOTH PLATE (R)	
34	S09123101	3	アナベルト4.37X15	BOLT, SOCKET M4.37X15	
35	025080132	1	ヒラザガネシヨウ8	WASHER, PLAIN S 8	
36	S47212001	1	クロスプレートホジヨイタ	CLOTH PLATE SUPPORT PLATE	
37	123185001	2	マルヒラネジ3.57X4.5	SCREW, OVAL M3.57X4.5	
38	S08642001	1	シタイトテンピンカバークミ	LOOPER THREAD TAKE-UP COVER ASSY	
39	123185001	2	マルヒラネジ3.57X4.5	SCREW, OVAL M3.57X4.5	
40	S08646100	1	マグネット	MAGNET	
41	S47209001	1	マエカバー	FRONT COVER	
42	S08651001	2	マエカバーササエ	FRONT COVER SUPPORT	
43	S08652000	2	マエカバーササエジク	FRONT COVER SUPPORT SHAFT	
44	153675001	2	アナトメネジ4.37	SET SCREW, SOCKET SM4.37	
45	060681612	4	バインド437-40X16	SCREW, BIND SM4.37-40X16	
46	114985001	1	ベツトカバートメバネ	SPRING, PLATE	
47	062680612	1	ナベコ4.37-40X6	SCREW, PAN SM4.37-40X6	
48	S08653001	1	バネウケネジ	SCREW	
49	142274009	2	ゴムセン4.2	RUBBER CAP, 4.2	
50	146586009	1	ゴムセン11	RUBBER CAP, 11	
51	062681412	1	ナベコ437-40X14	SCREW, PAN SM4.37-40X14	
52	105234003	1	ナツト4.37	NUT, SM4.37	
60	104450109	2	ゴムセン8	RUBBER CAP, 8	
61	154841009	1	ゴムセン16.8	RUBBER CAP, 16.8	
73	S47210001	1	マエカバーホジヨイタ	SUB FRONT COVER	
74	108960002	2	サラネジ3.57	SCREW, FLAT SM3.57	
80	100645003	2	ザガネ	WASHER	
83	025680133	2	ヒラザガネシヨウ4.37	WASHER, PLAIN S 4.37	
90	S28802001	1	アイガードクミ	EYE GUARD ASSY	
90-1	S28803001	1	アイガードダイ	EYE GUARD BASE	
90-2	S28804001	1	アイガードトリツケイタ	EYE GUARD SETTING PLATE	
90-3	S00075000	1	アイガード	EYE GUARD	
90-4	062660512	2	ナベコネジ318-40X5	SCREW, PAN SM3.18-40X5	
90-5	025030232	2	ヒラザガネチユウ3	WASHER, PLAIN M 3	
90-6	S07317001	1	ダンネジ3.57	SHOULDER SCREW, SM3.57	
90-7	028050246	1	バネザガネ2-5	WASHER, SPRING 2-5	
90-8	025050232	1	ヒラザガネチユウ5	WASHER, PLAIN M 5	

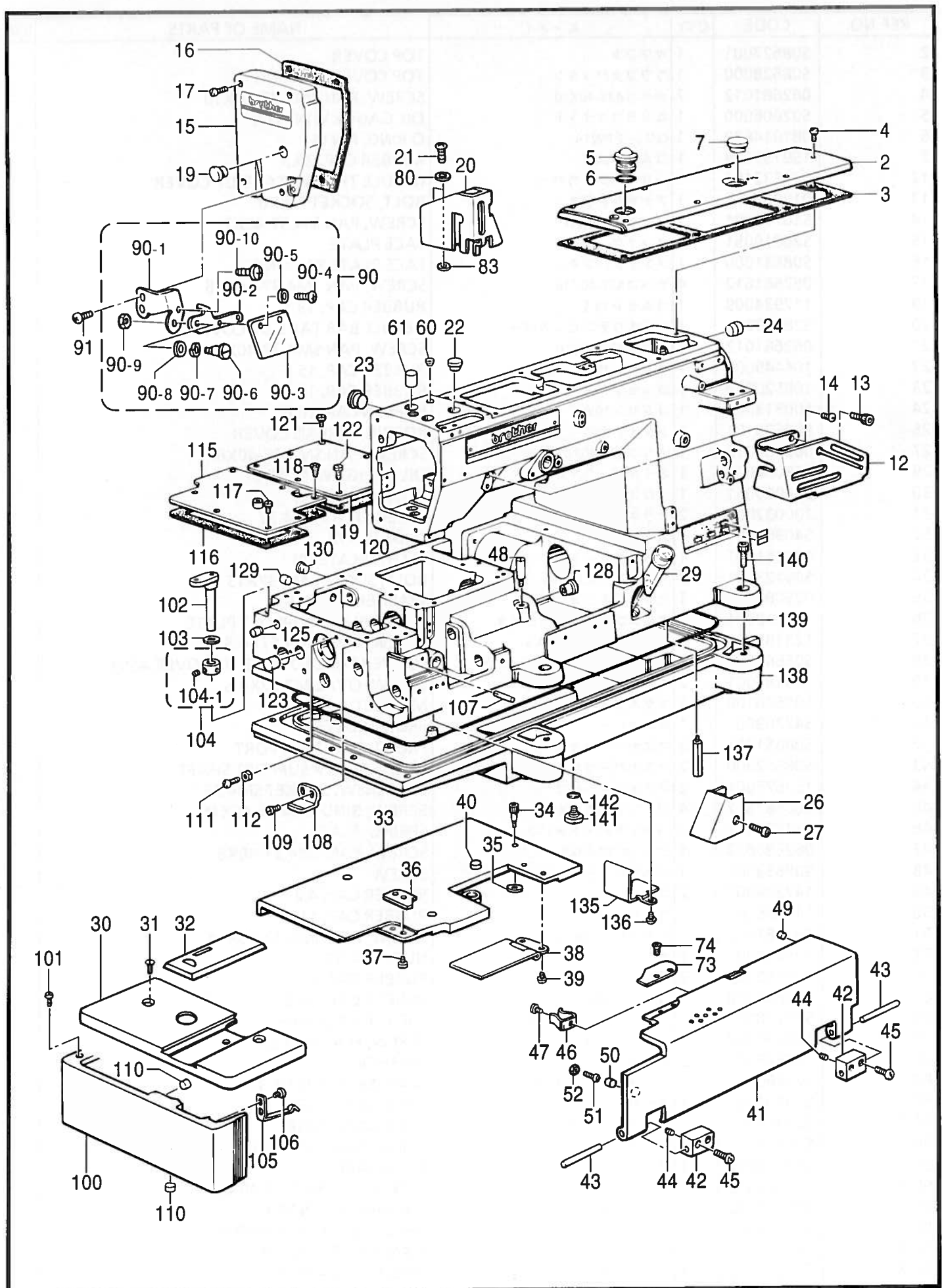



A. 主体関係 / Machine body / Maschinengehäuse / Corps de la machine / Cuerpo de la máquina

REF.NO.	CODE	Q'TY	ヒンメイ	NAME OF PARTS	RM
90-9	106129001	1	ナット3.57	NUT, SM3.57	
90-10	060670512	1	バインド357-40X5	SCREW, BIND SM3.57-40X5	
91	060680712	2	バインド437-40X7	SCREW, BIND SM4.37-40X7	
100	S08665001	1	ヨコカバー	SIDE COVER	
101	062680812	2	ナベコ437-40X8	SCREW, PAN SM4.37-40X8	
102	S00017001	1	クロスプレートササエジク	CLOTH PLATE SUPPORT SHAFT	
103	141183000	1	クロスプレートシート	CLOTH PLATE SHEET	
104	183893001	1	セットカラークミ	SET SCREW COLLAR ASSY	
104-1	101706001	2	トメネジ6.35	SET SCREW, SM6.35	
105	S08667001	1	ヨコカバートメイタバネ	PLATE SPRING	
106	060680712	2	バインド437-40X7	SCREW, BIND SM4.37-40X7	
107	140063001	1	ミゾツキピン	DOWEL PIN	
108	S08668001	1	ヨコカバーガイド	SIDE COVER GUIDE	
109	107407003	2	シメネジ4.37	SCREW, SM4.37	
110	146586009	2	ゴムセン11	RUBBER CAP, 11	
111	062681012	1	ナベコ437-40X10	SCREW, PAN SM4.37-40X10	
112	105234003	1	ナット4.37	NUT, SM4.37	
115	S40533001	1	オクリキコウカバー	FEED MECHANISM COVER	
116	S08670000	1	オクリキコウカバーハツキン	FEED MECHANISM COVER PACKING	
117	107407003	6	シメネジ4.37	SCREW, SM4.37	
118	151267001	1	サラネジ4.37	SCREW, FLAT SM4.37	
119	S08671101	1	ベッドウワカバー	BED UPPER COVER	
120	S08672000	1	ベッドウワカバハツキン	BED UPPER COVER PACKING	
121	107407003	4	シメネジ4.37	SCREW, SM4.37	
122	117516001	2	ボルト4.37	BOLT, M4.37	
123	S00313009	1	ゴムセン16.8	RUBBER CAP, 16.8	
125	146315009	1	ゴムセン10.7	RUBBER CAP, 10.7	
128	S08673000	1	ゴムセン14	RUBBER CAP, 14	
129	146586009	1	ゴムセン11	RUBBER CAP, 11	
130	104450109	1	ゴムセン8	RUBBER CAP, 8	
135	146457001	1	シキリイタ	OIL STOPPER PLATE	
136	062670612	2	ナベコ357-40X6	SCREW, PAN SM3.57-40X6	
137	151059001	4	ホンタイシチユウ	MACHINE BODY LEG	
138	S08674000	1	アブラウケ	OIL RESERVOIR	
139	S08675000	1	Oリング	O RING	
140	018081622	5	アナボルト8X16	BOLT, SOCKET M8X16	
141	110641002	1	ダンネジ9.52	STUD SCREW, SM9.52	
142	109203001	1	Oリング	O RING	

B. 上軸・針棒関係 / Upper shaft and needle bar mechanism / Obere Welle und Nadelstangenvorrichtung / Mécanisme de arbre supérieur et barra à aiguille / Mecanismo del eje superior y la barra de aguja

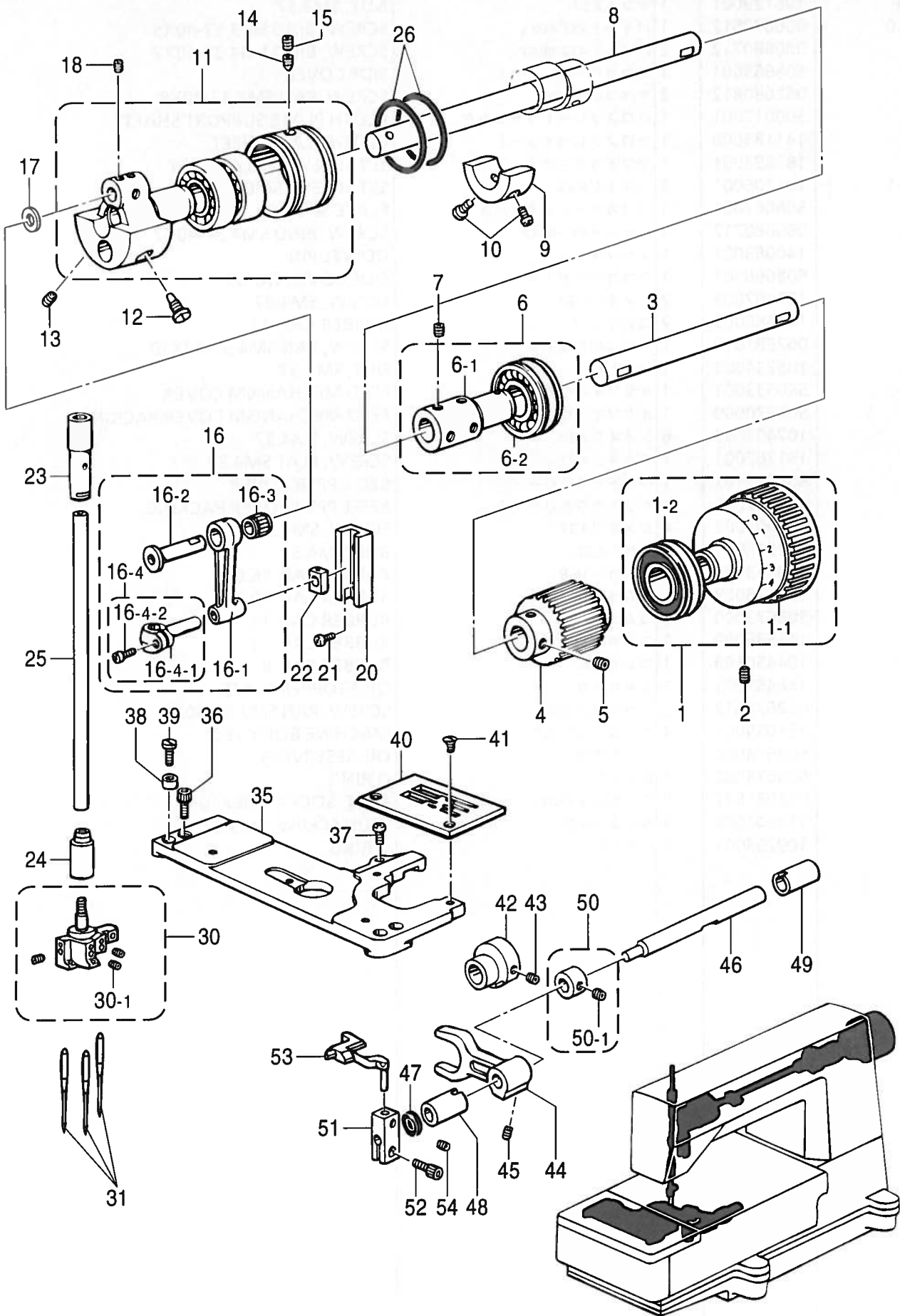

B. 上軸・針棒関係 / Upper shaft and needle bar mechanism / Obere Welle und Nadelstangenvorrichtung / Mécanisme de arbre supérieur et barra à aiguille / Mecanismo del eje superior y la barra de aguja

REF.NO.	CODE	Q'TY	ヒンメイ	NAME OF PARTS	RM
1	S28957001	1	フーリクミ	PULLEY ASSY	
1-1	S28958001	1	フーリ	PULLEY	
1-2	S14621001	1	タマジクウケ6204LLB	BALL BEARING, 6204LLB	
2	014770622	2	アナトメネジ6.35クボミ	SET SCREW, SOCKET (CP) SM6.35	
3	S08682001	1	ウワジクR	UPPER SHAFT, R	
4	S08683000	1	タイミングフーリU	TIMING PULLEY, U	
5	014770622	4	アナトメネジ6.35クボミ	SET SCREW, SOCKET (CP) SM6.35	
6	S08684101	1	ツギテLクミ	JOINT ASSY, L	
6-1	S08685001	1	ツギテL	JOINT, L	
6-2	S08686101	1	タマジクウケ6204LU	BALL BEARING, 6204LU	
7	014770622	4	アナトメネジ6.35クボミ	SET SCREW, SOCKET (CP) SM6.35	
8	S08687001	1	ウワジクL	ARM SHAFT (L)	
9	S08688051	1	ウエイト	WEIGHT	
10	062711012	2	ナベコ476-32X10	SCREW, PAN SM4.76-32X10	
11	S12725101	1	ハリボウ克蘭ククミ	NEEDLE BAR CRANK ASSY	
12	104464001	1	シメネジ7.14	SCREW, SM7.14	
13	014770622	1	アナトメネジ6.35クボミ	SET SCREW, SOCKET (CP) SM6.35	
14	118853001	1	アナトメネジ5.95	SET SCREW, SOCKET SM5.95	
15	014760622	1	アナトメネジ5.95	SET SCREW, SOCKET SM5.95	
16	S08692101	1	ハリボウレンカンクミ	THREAD TAKE-UP LEVER ASSY	
16-1	S08693001	1	ハリボウレンカン	NEEDLE BAR CONNECTING ROD	
16-2	S08694001	1	ハリボウレンカンジク	THREAD TAKE-UP LEVER SHAFT	
16-3	S09120001	1	ニードルジクウケ	NEEDLE ROLLER BEARING	
16-4	S30086001	1	ハリボウダキクミ	NEEDLE BAR CLAMP ASSY	
16-4-1	S08695001	1	ハリボウダキ	NEEDLE BAR CLAMP	
16-4-2	100064005	1	シメネジ3.57	SCREW, SM3.57	
17	107153001	1	ザガネ	WASHER	
18	152718001	3	アナトメネジ5.95	SET SCREW, SOCKET M5.95	
20	145688000	1	ハリボウアンナイ	NEEDLE BAR GUIDE	
21	062670612	2	ナベコ357-40X6	SCREW, PAN SM3.57-40X6	
22	102630001	1	ハリボウアンナイカクコマ	SLIDE BLOCK, N-BAR GUIDE	
23	S08696000	1	ハリボウメタルU	NEEDLE BAR BUSH, U	
24	S08697000	1	ハリボウメタルD	NEEDLE BAR BUSH, D	
25	S08698001	1	ハリボウ	NEEDLE BAR	
26	081046870	2	OリングS46	O RING, S46	
30	S47183001	1	ハリドメMクミ	NEEDLE CLAMP ASSY	
30-1	146427001	3	アナトメネジ3.18クボミ	SET SCREW, SOCKET (CP) SM3.18	
31	S08715018	3	ミシンハリUYX128GAS	NEEDLE, UYX128GAS (#18)	
35	S08716301	1	ハリイタササエイタ	SUPPORTER PLATE, NEEDLE PLATE	
36	018681022	2	アナホルト4.37X10	BOLT, SOCKET SM4.37X10	
37	062680812	1	ナベコ437-40X8	SCREW, PAN SM4.37-40X8	
38	S09124001	2	ハリイタササエイタカラー	COLLER	
39	S13385001	2	シメネジ3.57X10	SCREW, SM3.57X10	
40	S47185001	1	ハリイタM	NEEDLE PLATE	
41	S09121001	2	マルサラネジ3.57X6	SCREW, FLAT M3.57X6	
42	S08750001	1	ハリウケBヘンシンリン	NEEDLE GUARD REAR ECCENTRIC WHEEL	
43	014680622	2	アナトメネジ4.37クボミ	SET SCREW, SOCKET (CP) SM4.37	
44	S08751001	1	ハリウケBレバー	NEEDLE GUARD REAR LEVER	
45	014680622	2	アナトメネジ4.37クボミ	SET SCREW, SOCKET (CP) SM4.37	
46	S08752001	1	ハリウケBジク	NEEDLE GUARD REAR SHAFT	
47	155539000	1	ダストシール	DUST SEAL	
48	S08753000	1	ハリウケBジクメタルL	KNIFE DRIVING SHAFT BUSH (L)	
49	S08754000	1	ハリウケBジクメタルR	KNIFE DRIVING SHAFT BUSH (R)	
50	S03704002	1	セツトカラークミ	SET SCREW COLLAR ASSY	
50-1	014770622	2	アナトメネジ6.35クボミ	SET SCREW, SOCKET (CP) SM6.35	
51	S08755101	1	ハリウケBトリツケダイ	NEEDLE GUARD BACK SET BRACKET	
52	018681022	1	アナホルト4.37X10	BOLT, SOCKET SM4.37X10	
53	S47186001	1	ウシロハリウケM	REAR NEEDLE GUARD (M)	
54	014680422	1	アナトメネジ4.37クボミ	SET SCREW, SOCKET (CP) SM4.37	

C . 押工関係 / Presser foot mechanism / Stoffdrückerfuß / Mécanisme de pied presseur / Mecanismo de la prensa tela

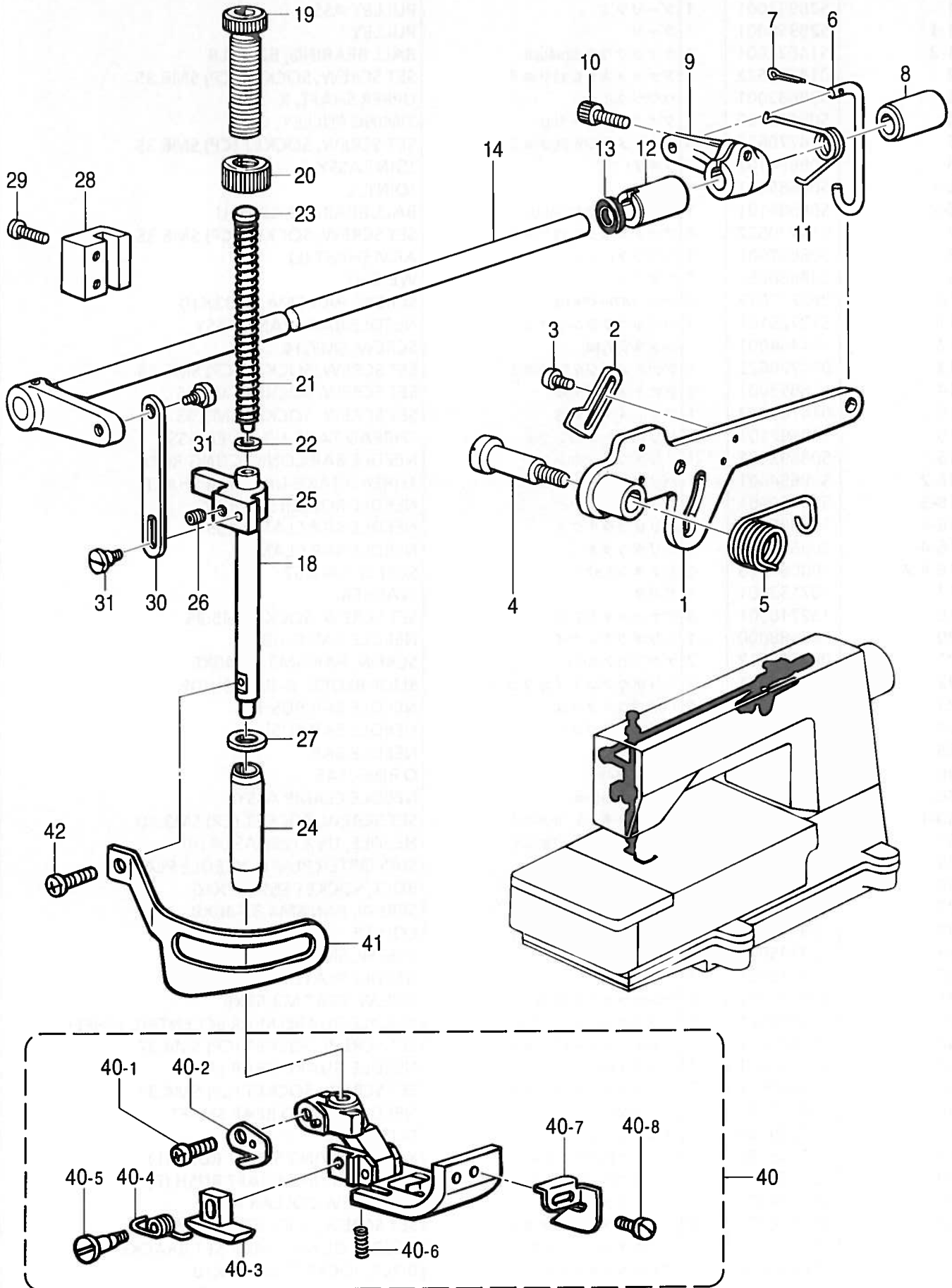

C. 押工関係 / Presser foot mechanism / Stoffdrückerfuß / Mécanisme de pied presseur /  
Mecanismo de la prensa tela

REF.NO.	CODE	Q'TY	ヒンメイ	NAME OF PARTS	RM
1	S08767001	1	オサエアゲレバーR	PRESSER BAR LIFTER LEVER (R)	
2	S08768001	1	オサエアゲストツハ	PRESSER BAR LIFTER LEVER STOPPER	
3	060680712	2	バインド437-40X7	SCREW, BIND SM4.37-40X7	
4	148372001	1	ダンネジ7.94	STUD SCREW, M7.94	
5	143325001	1	オサエアジアゲレバーバネ	SPRING	
6	S08769001	1	オサエアゲリンク	PRESSER BAR LIFTER LINK	
7	110793001	1	ワリピン	PIN, COTTER	
8	155220000	1	ホジヨアツメタルR	AUTO PRESSER ARM BUSH (R)	
9	154956001	1	オサエアジアゲMレバー	PRESSER FOOT LIFTER INSIDE LEVER	
10	018771432	1	アナボルト635-40X14	BOLT, SOCKET SM6.35-40X14	
11	154957001	1	オサエアゲMレバーバネ	SPRING	
12	S08770000	1	ジクメタル	SHAFT BUSH	
13	155539000	1	ダストシール	DUST SEAL	
14	S08771001	1	オサエアゲレバーLクミ	PRESSER BAR LIFTER LEVER (L) ASSY	
18	S08774001	1	オサエボウ	PRESSER BAR	
19	S31012001	1	オサエチヨウセツネジ	PRESSER ADJUSTING SCREW	
20	S31013001	1	チヨウセツネジツマミナツト	PRESSER ADJUSTING NUT	
21	141728001	1	オサエバネ	PRESSER SPRING	
22	140407001	1	ザガネ	WASHER	
23	141208001	1	オサエバネアンナイ	SPRING GUIDE	
24	145472001	1	オサエボウメタル	PRESSER BAR BUSH	
25	S00879001	1	オサエボウダキ	PRESSER BAR CLAMP	
26	014760622	1	アナトメネジ5.95	SET SCREW, SOCKET SM5.95	
27	154596000	1	イトキリカムレバークツシヨン	CUSHION	
28	S08775000	1	オサエボウアンナイ	PRESSER BAR GUIDE	
29	062681412	2	ナベコ437-40X14	SCREW, PAN SM4.37-40X14	
30	S08776001	1	オサエアゲイタ	PRESSER BAR LIFTER PLATE	
31	S08777001	2	ダンネジ4.37	SHOULDER SCREW, M4.37	
40	S47187001	1	オサエMクミ	PRESSER FOOT ASSY	
40-1	062671212	1	ナベコ357-40X12	SCREW, PAN SM3.57-40X12	
40-2	S20118151	1	カラヌイメス	TRIMMING KNIFE	
40-3	S47190001	1	カラカンオサエM	CHAIN GUIDE, M	
40-4	S47191001	1	カラカンオサエMバネ	SPRING	
40-5	S47192001	1	ダンネジ2.38	SHOULDER SCREW, SM2.38	
40-6	S40546001	1	カラカンオサエバネ	CHAIN GUIDE SPRING	
40-7	S47193001	1	ガイドM	GUIDE (M)	
40-8	S01295001	1	シメネジ2.38X3.5	SCREW, SM2.38X3.5	
41	S47213001	1	フィンガーガードM	FINGER GUARD	
42	062670812	1	ナベコ3.57-40X8	SCREW, PAN SM3.57-40X8	

D. 送り関係 / Feed mechanism / Transportvorrichtung / Mécanisme de l'entraînement / Mecanismo de la alimentación

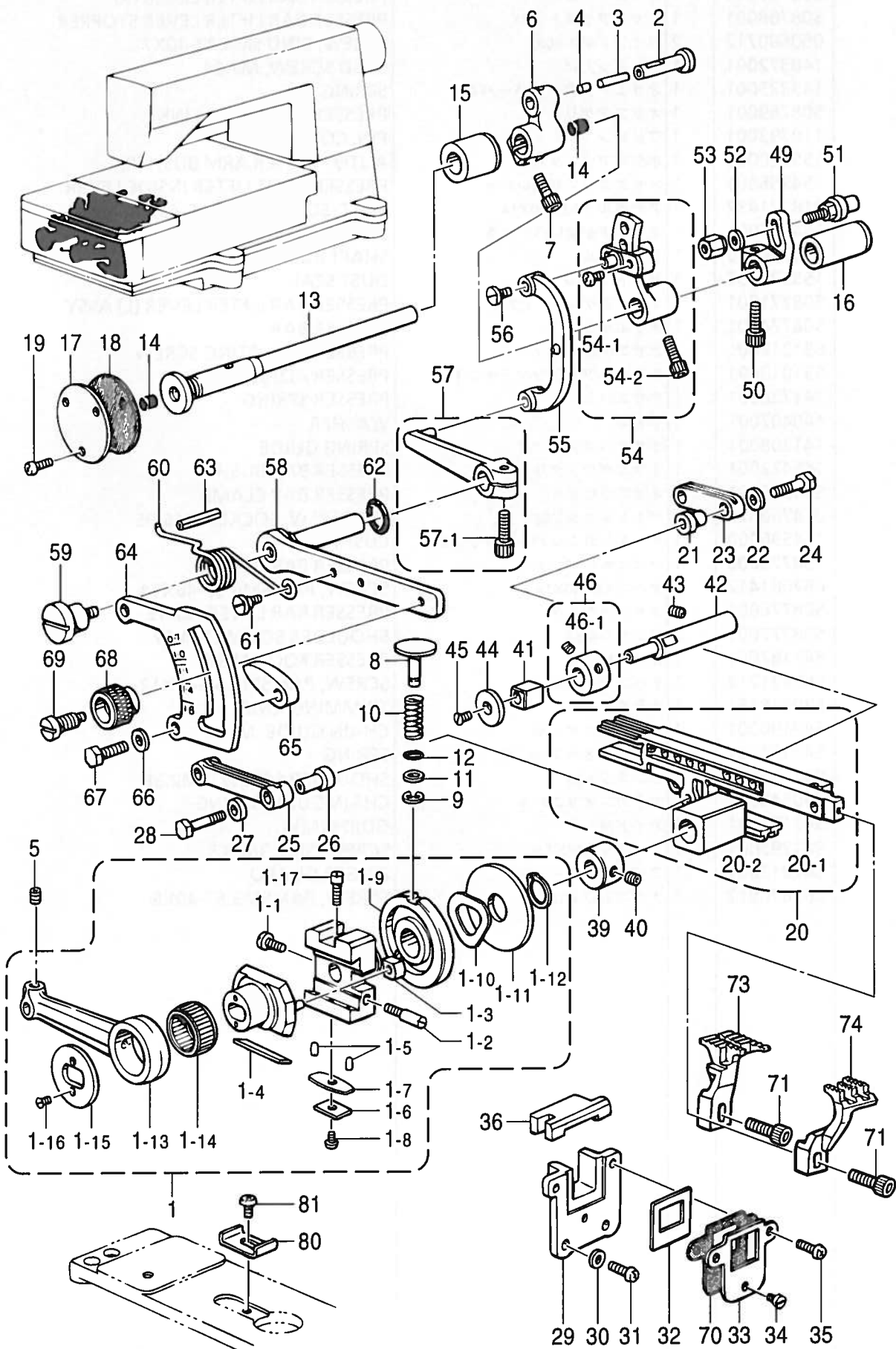

D. 送り関係 / Feed mechanism / Transportvorrichtung / Mécanisme de l'entraînement /  
Mecanismo de la alimentación

REF.NO.	CODE	Q'TY	ヒンメイ	NAME OF PARTS	RM
1	146528102	1	ヘンシンリンクミ	ECCENTRIC WHEEL ASSY	
1-1	S16498001	1	シメネジ4.37	SCREW, SM4.37	
1-2	145663001	1	トメネジ4.37	SET SCREW, SM4.37	
1-3	140165001	1	チヨウセツピンカワコマ	SLIDE BLOCK	
1-4	146401001	1	ジブ	GIB	
1-5	146402001	2	ジブオサエヒン	PIN	
1-6	146403001	1	ジブオサエイタバネS	PLATE SPRING, S	
1-7	146404001	1	ジブオサエイタバネL	PLATE SPRING, L	
1-8	062660512	1	ナベコネジ318-40X5	SCREW, PAN SM3.18-40X5	
1-9	144053001	1	ヘンシンチヨウセツカムクミ	ECCENTRIC WHEEL ADJ. CAM ASSY	
1-10	144055001	1	ナミバネ	SPRING, WAVE	
1-11	146529001	1	ザガネ	WASHER	
1-12	048150143	1	トメワジクヨウC15	RETAINING RING, C15	
1-13	146530001	1	オクリロッド	FEED ROD	
1-14	146531001	1	ニードルジクウケ20	NEEDLE ROLLER BEARING 20	
1-15	140176001	1	オクリロッドオサエイタ	FEED ROD PRESSER PLATE	
1-16	117517003	2	サラネジ2.38	SCREW, FLAT SM2.38	
1-17	100025002	2	シメネジ4.76	SCREW, SM4.76	
2	146532001	1	オクリロッドヒン	PIN	
3	147318000	1	ヒン	PIN	
4	140326009	1	ゴムセン3.3	RUBBER CAP, 3.3	
5	100251001	1	トメネジ6.35	SET SCREW, SM6.35	
6	146533001	1	オクリウデ	FEED ARM	
7	018771432	1	アナボルト635-40X14	BOLT, SOCKET SM6.35-40X14	
8	S08870001	1	フツシユボタン	PUSH BUTTON	
9	048040342	1	トメワE4	RETAINING RING, E4	
10	S08871001	1	ボタンジクバネ	SPRING	
11	153484001	1	ザガネ4.76	WASHER, PLAIN 4.76	
12	081003670	1	OリングPW3	O RING, PW3	
13	146538101	1	オクリジク	FEED SHAFT	
14	140327001	2	ゴムセン6.3	RUBBER CAP, 6.3	
15	146539000	1	オクリジクメタルL	FEED SHAFT BUSH, L	
16	146540000	1	オクリジクメタルR	FEED SHAFT BUSH (R)	
17	155144001	1	オクリジクメタルLフタ	FEED SHAFT BUSH (L) CAP	
18	155145000	1	ハツキン	PACKING	
19	062670812	3	ナベコ3.57-40X8	SCREW, PAN SM3.57-40X8	
20	S08872001	1	オクリダイカクゴマクミ	FEED BAR SLIDE BLOCK ASSY	
20-1	S08873001	1	オクリダイクミ	FEED BRACKET ASSY	
20-2	146544000	1	ジヨウゲオクリカクゴマ	FEED LIFTING SLIDE BLOCK	
21	140207001	1	シユオクリリンクブシユ	MAIN FEED LINK BUSH	
22	S23359001	1	ザガネ	WASHER	
23	140209001	1	シユオクリリンク	MAIN FEED LINK	
24	140210001	1	シユオクリリンクジクS	MAIN FEED LINK SHAFT (S)	
25	146554001	1	サドウオクリリンク	DIFFERENTIAL FEED LINK	
26	146555001	1	サドウオクリリンクブシユ	DIFFERENTIAL FEED LINK BUSH	
27	S23359001	1	ザガネ	WASHER	
28	140217001	1	オクリリンクジクL	FEED LINK SHAFT (L)	
29	155151000	1	オクリダイアンナイ	FEED BAR GUIDE	
30	100645003	2	ザガネ	WASHER	
31	062681012	2	ナベコ437-40X10	SCREW, PAN SM4.37-40X10	
32	155177100	1	ボウジンイタ	FRAGMENT PROTECTOR PLATE	
33	155178001	1	ボウジンイタササエ	FRAGMENT PROTECTOR SUPPORT	
34	S39086001	1	ナベコ357-40X3.5	SCREW, PAN SM3.57-40X3.5	
35	062681012	2	ナベコ437-40X10	SCREW, PAN SM4.37-40X10	
36	S08876000	1	オクリダイボウジンタイ	FEED BAR FRAGMENT PROTECTOR BASE	
39	146741000	1	セツトカラー	SET SCREW COLLAR	
40	101706001	1	トメネジ6.35	SET SCREW, SM6.35	
41	146547000	1	オクリダイカクゴマ	FEED BAR SLIDE BLOCK	
42	146548101	1	オクリダイカクゴマジク	FEED BAR SLIDE BLOCK SHAFT	

D. 送り関係 / Feed mechanism / Transportvorrichtung / Mécanisme de l'entraînement / Mecanismo de la alimentación

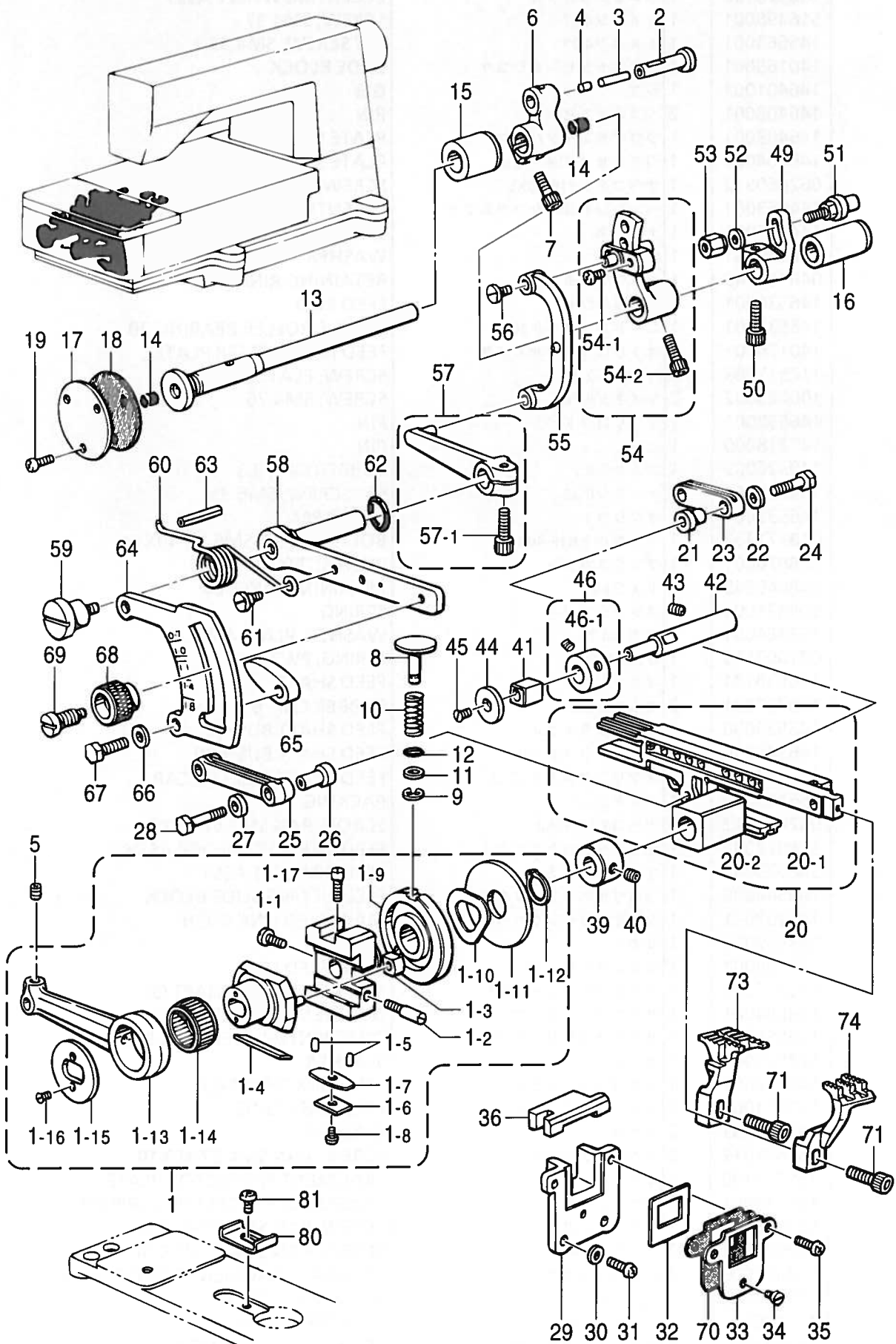



D. 送り関係 / Feed mechanism / Transportvorrichtung / Mécanisme de l'entraînement /  
Mecanismo de la alimentación

REF.NO.	CODE	Q'TY	ヒンメイ	NAME OF PARTS	RM
43	014780622	1	アナトメネジ6.35クボミ	SET SCREW, SOCKET (CP) SM6.35	
44	S08877001	1	オクリダイカクゴマアテイタ	SLIDE PLATE	
45	107272002	1	サラネジ4.37	SCREW, FLAT SM4.37	
46	S03704002	1	セットカラークミ	SET SCREW COLLAR ASSY	
46-1	014770622	2	アナトメネジ6.35クボミ	SET SCREW, SOCKET (CP) SM6.35	
49	140205001	1	シユオクリウデ	MAIN FEED ARM	
50	018771432	1	アナボルト635-40X14	BOLT, SOCKET SM6.35-40X14	
51	143564001	1	シユオクリジク	MAIN FEED SHAFT	
52	113431002	1	ザガネ	WASHER	
53	143565001	1	ナツト4.76	NUT, SM4.76	
54	S08878001	1	サドウオクリウデクミ	DIFFERENTIAL FEED ARM ASSY	
54-1	062660712	2	ナベコ318-40X7	SCREW, PAN SM3.18-40X7	
54-2	018771432	1	アナボルト635-40X14	BOLT, SOCKET SM6.35-40X14	
55	146556001	1	サドウリンク	DIFFERENTIAL FEED ADJUST LINK	
56	148834001	1	シメネジ3.57	SCREW, M3.57	
57	S08879001	1	リンクレバーネジツキ	DIFFERENTIAL FEED LINK LEVER ASSY	
57-1	018771432	1	アナボルト635-40X14	BOLT, SOCKET SM6.35-40X14	
58	S08880001	1	サドウチヨウセツレバー	DIFFERENTIAL FEED ADJUST LEVER	
59	146559001	1	ダンネジ5.56	STUD SCREW, M5.56	
60	146560101	1	レバーバネ	LEVER SPRING	
61	100294002	1	ダンネジ4.76	SHOULDER SCREW, SM4.76	
62	109203001	1	リング	O RING	
63	047502242	1	スプリングピンAW5	PIN, SPRING ROLL AW5	
64	S08881101	1	サドウリヨウメモリイタ	DIFFERENTIAL STITCH CONTROL	
65	146563001	2	チヨウセツレバーストツハ	STOPPER, ADJUSTING LEVER	
66	025770232	2	ヒラザガネチユウ6.35	WASHER, PLAIN M 6.35	
67	017781412	2	ボルト6.35X14	BOLT, SM6.35X14	
68	155175051	1	セットネジツマミ	SET SCREW, KNOB	
69	155176001	1	セットネジ	SET SCREW	
70	S08467000	1	ハツキン	PACKING	
71	154965001	2	アナボルト3.57X8	BOLT, SOCKET SM3.57X8	
73	S47195001	1	シユオクリバム	MAIN FEED DOG	
74	S47196001	1	サドウオクリバム	DIFFERENTIAL FEED DOG	
80	S16249001	1	プツシユボタンストツバ	PUSH BUTTON STOPPER	
81	060680512	1	バインド437-40X5	SCREW, BIND SM4.37-40X5	

E . 下軸關係 / Lower shaft mechanism / Untere Welle / Mécanisme de l'arbre inférieur / Mecanismo del eje inferior

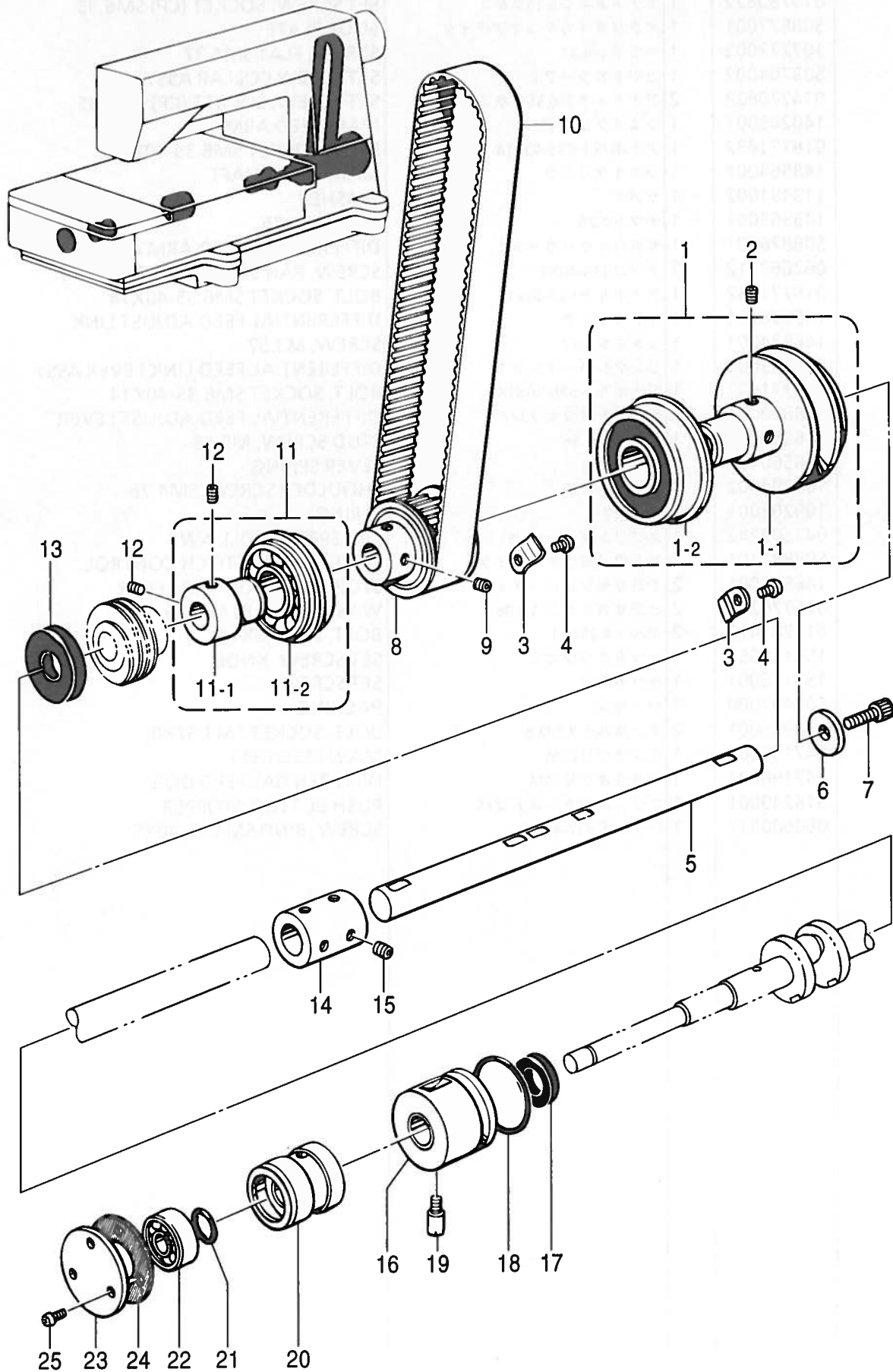

E. 下軸関係 / Lower shaft mechanism / Untere Welle / Mécanisme de l'arbre inférieur /  
Mecanismo del eje inferior

REF.NO.	CODE	Q'TY	ヒンメイ	NAME OF PARTS	RM
1	S08889101	1	Vベルトプーリクミ	V-BELT PULLEY ASSY	
1-1	S08890001	1	Vベルトプーリ	V-BELT PULLEY	
1-2	S14622001	1	タマジクウケ6304VV	BALL BEARING, 6304VV	
2	014780622	2	アナトメネジ6.35クボミ	SET SCREW, SOCKET (CP) SM6.35	
3	153734001	2	アームササエイタバネ	PLATE SPRING	
4	062680612	2	ナベコ4.37-40X6	SCREW, PAN SM4.37-40X6	
5	S08891001	1	シタジクR	LOWER SHAFT (R)	
6	154886001	1	ザガネ	WASHER	
7	018771432	1	アナボルト635-40X14	BOLT, SOCKET SM6.35-40X14	
8	S08892001	1	タイミングプーリDクミ	TIMING PULLEY (D) ASSY	
9	014770622	2	アナトメネジ6.35クボミ	SET SCREW, SOCKET (CP) SM6.35	
10	S08895002	1	タイミングベルト	TIMING BELT	
11	S08896101	1	タマジクウケクミ	BALL BEARING ASSY	
11-1	S08897001	1	タマジクウケブシュ	BALL BEARING BUSH	
11-2	S14623001	1	タマジクウケ6204DV	BALL BEARING, 6204DV	
12	014770622	2	アナトメネジ6.35クボミ	SET SCREW, SOCKET (CP) SM6.35	
13	S08898000	1	オイルシール	OIL SEAL	
14	S08899001	1	ジクツギテ	SHAFT JOINT	
15	014770622	4	アナトメネジ6.35クボミ	SET SCREW, SOCKET (CP) SM6.35	
16	S08900000	1	クランクジクメタルRクミ	LOWER SHAFT BUSH (R) ASSY	
17	S08903000	1	ダストシール	DUST SEAL	
18	081032870	1	OリングS32	O RING, S32	
19	S08967001	1	シメネジ4.76	SCREW, SM4.76	
20	S08904000	1	クランクジクメタルLクミ	CRANK SHAFT BUSH (L) ASSY	
21	114294001	1	Oリング	O RING	
22	072600000	1	タマジクウケ6000	BALL BEARING, 6000	
23	143311001	1	ベアリングフタ	BEARING COVER	
24	143312000	1	ベアリングフタハツキン	BEARING COVER PACKING	
25	062670812	3	ナベコ3.57-40X8	SCREW, PAN SM3.57-40X8	

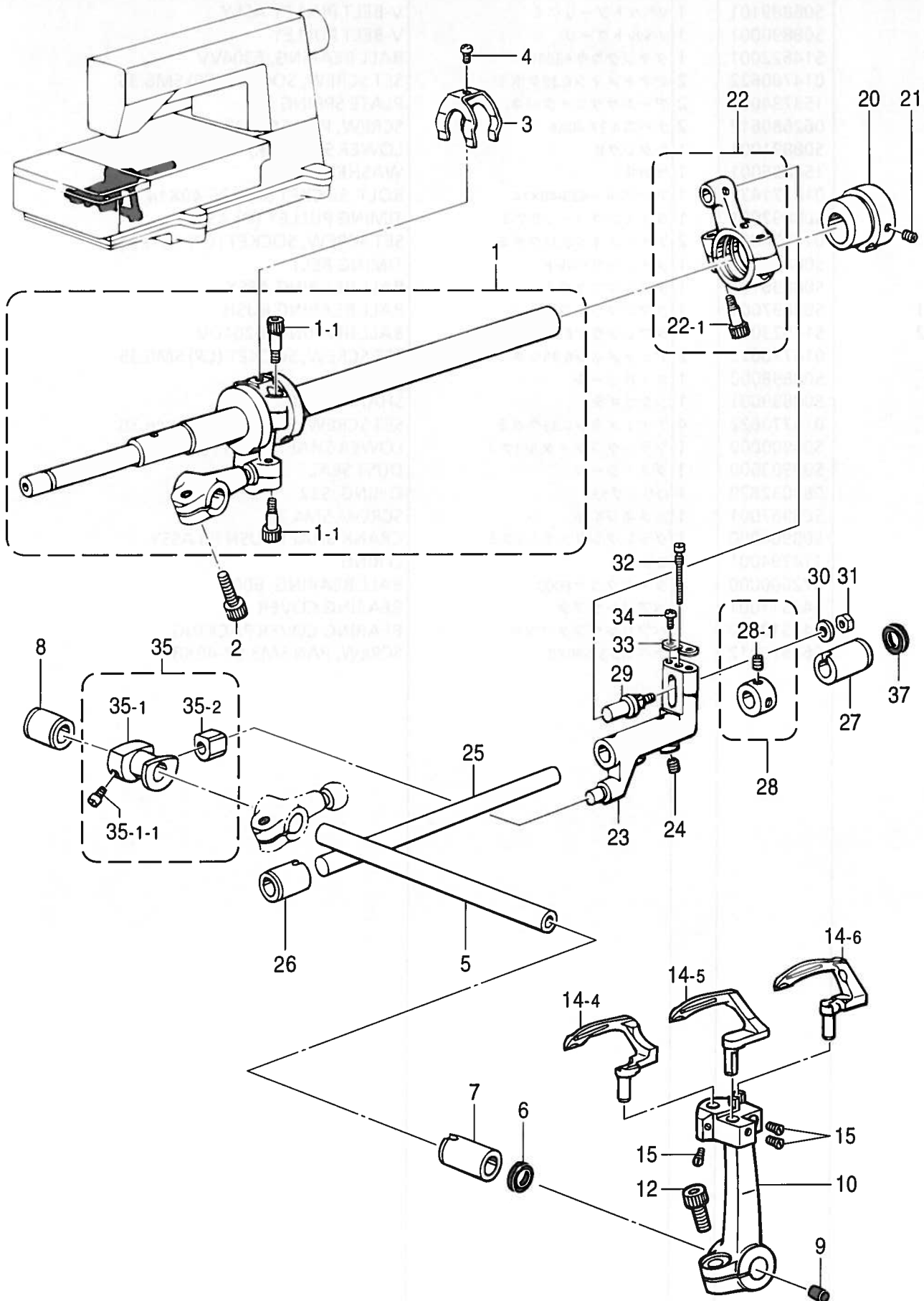

F. ルーパー関係 / Looper mechanism / Greifer / Mécanisme des griffes / Mecanismo del presilladora

REF.NO.	CODE	Q'TY	ヒンメイ	NAME OF PARTS	RM
1	S40567001	1	ルーハクランクジククミ	LOOPER CRANK SHAFT	
1-1	148425001	4	アナボルト4.37X14	BOLT, SOCKET SM4.37X14	
2	018771432	1	アナボルト635-40X14	BOLT, SOCKET SM6.35-40X14	
3	110704001	1	ウワルハロツドフレドメ	LOOPER CONNECTING ROD STOPPER	
4	062660412	1	ナベコ318-40X4	SCREW, PAN SM3.18-40X4	
5	S08910001	1	ルーハジク	LOOPER SHAFT	
6	155539000	1	ダストシール	DUST SEAL	
7	S08770000	1	ジクメタル	SHAFT BUSH	
8	S08911000	1	ルーハジクメタルB	LOOPER SHAFT BUSHING (B)	
9	140327001	1	ゴムセン6.3	RUBBER CAP, 6.3	
10	S47200001	1	ルーハホルダム	LOOPER HOLDER	
12	018771432	1	アナボルト635-40X14	BOLT, SOCKET SM6.35-40X14	
14-4	S47197001	1	ルーハA	LOOPER (A)	
14-5	S47198001	1	ルーハB	LOOPER (B)	
14-6	S47199001	1	ルーハC	LOOPER (C)	
15	104908004	3	アタマツキトメネジ4.37	SET SCREW, SM4.37	
20	S08914001	1	ゼンゴヘンシンリン	LONGITUDINAL ECCENTRIC CAM	
21	014680622	2	アナトメネジ4.37クボミ	SET SCREW, SOCKET (CP) SM4.37	
22	146624101	1	ゼンゴロツドクミ	LONGITUDINAL FEED ROD ASSY	
22-1	148425001	2	アナボルト4.37X14	BOLT, SOCKET SM4.37X14	
23	S08915001	1	ゼンゴレバー	LONGITUDINAL LEVER	
24	014770622	2	アナトメネジ6.35クボミ	SET SCREW, SOCKET (CP) SM6.35	
25	S11588001	1	ゼンゴレバージク	LONGITUDINAL FEED SHAFT	
26	S08917000	1	レバージクメタルL	LONGITUDINAL FEED SHAFT BUSH (L)	
27	S08754000	1	ハリウケBジクメタルR	KNIFE DRIVING SHAFT BUSH (R)	
28	S03704002	1	セツトカラークミ	SET SCREW COLLAR ASSY	
28-1	014770622	2	アナトメネジ6.35クボミ	SET SCREW, SOCKET (CP) SM6.35	
29	S08918001	1	ゼンゴロツトヒン	PIN	
30	148847001	1	ザガネ	WASHER, PLAIN 4.76	
31	110161006	1	ナツト4.76	NUT, SM4.76	
32	S08919001	1	ヘンシンチヨウセツネジ	ADJUST SCREW	
33	S08920001	1	ヘンシントメイタ	ECCENTRIC WHEEL STOPPER PLATE	
34	062630612	2	ナベコ238-56X6	SCREW, PAN SM2.38-56X6	
35	S08921101	1	ゼンゴコマクミ	LONGITUDINAL BLOCK ASSY	
35-1	S09251001	1	ゼンゴコマネジツキ	LONGITUDINAL BLOCK WITH SCREW	
35-1-1	120990001	2	アタマツキトメネジ4.37	SET SCREW, SM4.37	
35-2	140313001	1	ゼンゴレバーカクゴマ	LONGITUDINAL FEED LEVER SLIDE BLOCK	
37	S11589000	1	ダストシール	DUST SEAL	

G . スプレダー関係 / Spreader mechanism / Spreizvorrichtung / Mécanisme de l'étendeur  
 / Mecanismo extendedor

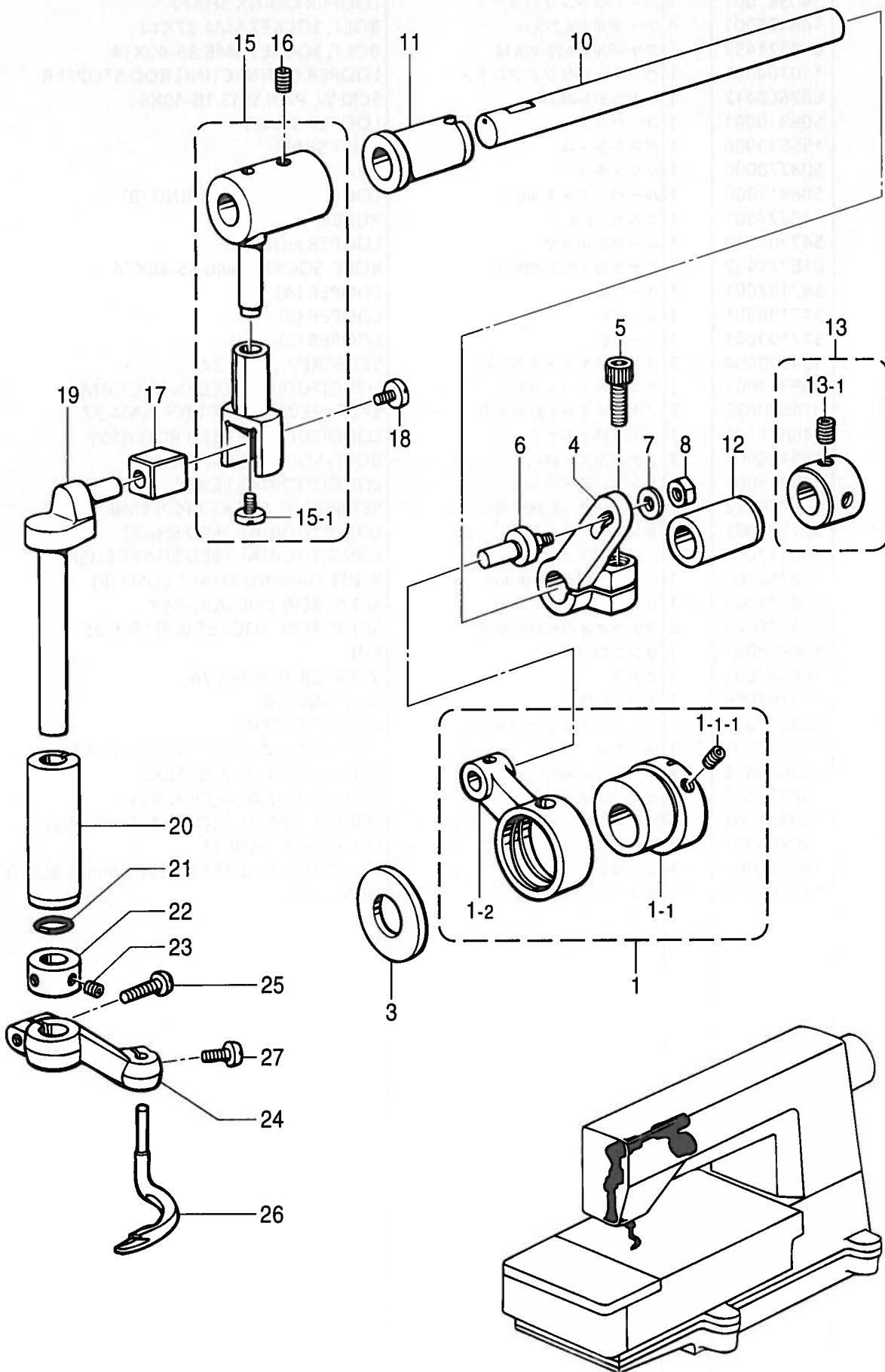

G. スプレダ－関係 / Spreader mechanism / Spreizvorrichtung / Mécanisme de l'étendeur / Mecanismo extendedor

REF.NO.	CODE	Q'TY	ヒンメイ	NAME OF PARTS	RM
1	S47201001	1	スプレダヘンシンリンMクミ	SPREADER ECCENTRIC WHEEL ASSY	
1-1	S47202001	1	ヘンシンリンMネジツキ	ECCENTRIC WHEEL WITH SCREW	
1-1-1	014680622	2	アナトメネジ4.37クボミ	SET SCREW, SOCKET (CP) SM4.37	
1-2	S08925000	1	スプレダロッド	SPREADER ROD	
3	101482001	1	レンカンシキリイタ	CONNECTING ROD PARTITION PLATE	
4	S08926201	1	スプレダレバ－R	SPREADER LEVER (R)	
5	018771432	1	アナボルト635-40X14	BOLT, SOCKET SM6.35-40X14	
6	S13809001	1	スプレダロッドピン	PIN	
7	148847001	1	ザガネ	WASHER, PLAIN 4.76	
8	110161006	1	ナツト4.76	NUT, SM4.76	
10	S08927001	1	スプレダジク	SPREADER SHAFT	
11	148196000	1	ウワメスサドウウデメタルL	SPREADER SHAFT BUSH, L	
12	148197000	1	ウワメスサドウウデメタルR	SPREADER SHAFT BUSH, R	
13	S03421001	1	セツトカラークミ	SET SCREW COLLAR ASSY	
13-1	014770622	2	アナトメネジ6.35クボミ	SET SCREW, SOCKET (CP) SM6.35	
15	S08928001	1	スプレダレバ－Lクミ	SPREADER LEVER (L) ASSY	
15-1	148834001	1	シメネジ3.57	SCREW, M3.57	
16	014770622	2	アナトメネジ6.35クボミ	SET SCREW, SOCKET (CP) SM6.35	
17	146547000	1	オクリダイカクゴマ	FEED BAR SLIDE BLOCK	
18	148834001	1	シメネジ3.57	SCREW, M3.57	
19	S08931001	1	スプレダタテジク	SPREADER VERTICAL SHAFT	
20	S08932000	1	スプレダタテジクメタル	SPREADER VERTICAL SHAFT BUSH	
21	081007670	1	OリングPW7	O RING, PW7	
22	110197001	1	セツトカラ－	SET SCREW COLLAR	
23	014680422	2	アナトメネジ4.37クボミ	SET SCREW, SOCKET (CP) SM4.37	
24	S08933051	1	スプレダホルダ	SPREADER HOLDER	
25	062681412	1	ナベコ437-40X14	SCREW, PAN SM4.37-40X14	
26	S47204001	1	スプレダM	SPREADER (M)	
27	062681012	1	ナベコ437-40X10	SCREW, PAN SM4.37-40X10	

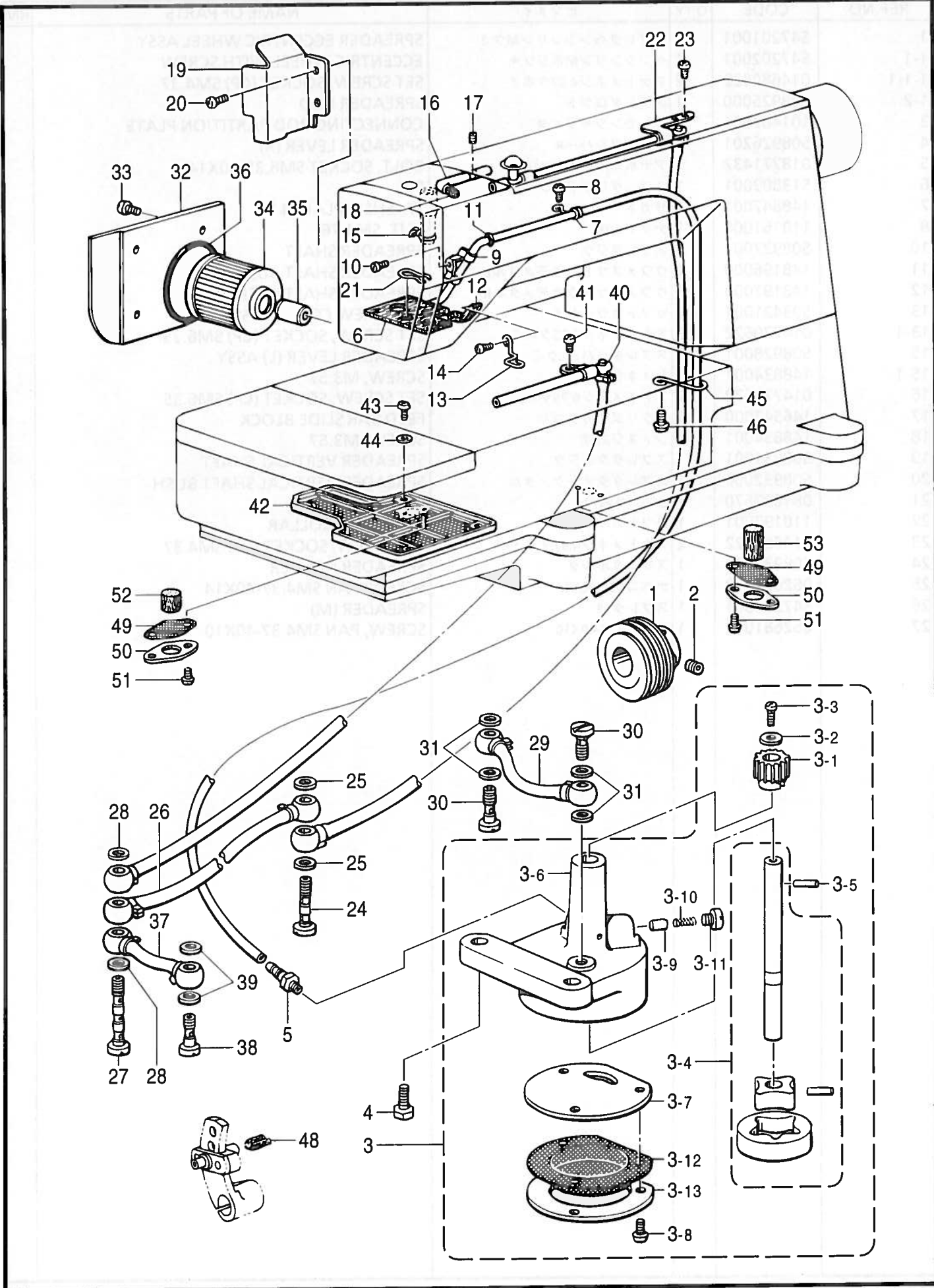



H. 給油潤滑関係 / Lubrication / Schmierung / Lubrification / Lubricación

REF.NO.	CODE	Q'TY	ヒンメイ	NAME OF PARTS	RM
1	S08935001	1	ウオーム	WORM	
2	014770622	2	アナトメネジ6.35クボミ	SET SCREW, SOCKET (CP) SM6.35	
3	S08936201	1	トロコイドポンプクミ	PUMP ASSY	
3-1	144619000	1	ウオームホイール	WORM WHEEL	
3-2	025350332	1	ヒラザガネダイ3.5	WASHER, PLAIN L 3.5	
3-3	062670812	1	ナベコ3.57-40X8	SCREW, PAN SM3.57-40X8	
3-4	S08937101	1	ポンプロータークミ	PUMP INNER ROTER ASSY	
3-5	144622001	1	ミソツキピンEガタ	DOWEL PIN (E)	
3-6	S08939100	1	ポンプケース	PUMP CASE	
3-7	147527000	1	ポンプフタ	PUMP COVER	
3-8	062671012	3	ナベコ357-40X10	SCREW, PAN SM3.57-40X10	
3-9	144875001	1	プランジャー	PLUNGER	
3-10	144876001	1	プランジャーバネ	SPRING	
3-11	112467002	1	シメネジ6.35	SCREW, SM6.35	
3-12	147528100	1	口カモウ	OIL FILTER	
3-13	147529000	1	口カモウオサエ	OIL FILTER FLANGE	
4	017781412	2	ボルト6.35X14	BOLT, SM6.35X14	
5	142359001	1	オイルクチ	OIL FEEDING PIPE	
6	S08940000	1	チューブクミ	OIL TUBE ASSY	
7	112743001	1	クミヒモササエ	WICK SUPPORT	
8	062670612	1	ナベコ357-40X6	SCREW, PAN SM3.57-40X6	
9	151429001	1	チューブホルダ	TUBE HOLDER	
10	062670612	1	ナベコ357-40X6	SCREW, PAN SM3.57-40X6	
11	118770001	1	ハツキン	PACKING	
12	S08943000	1	カクゴマフェルト	FELT	
13	S08944001	1	フェルトオサエ	FELT SUPPORT	
14	062670612	1	ナベコ357-40X6	SCREW, PAN SM3.57-40X6	
15	157840000	1	クミヒモ3X3	WICK, 3X3 L = 100	
16	S08945001	1	オイルパイプ	OIL PIPE	
17	014680622	1	アナトメネジ4.37クボミ	SET SCREW, SOCKET (CP) SM4.37	
18	S08946000	1	フェルト	FELT	
19	S08947001	1	オイルヨケイタ	OIL STOPPER PLATE	
20	062670612	2	ナベコ357-40X6	SCREW, PAN SM3.57-40X6	
21	145737001	1	フェルトオサエ	FELT SUPPORT	
22	S08948001	1	ロッドオイルパイプUクミ	MAIN OIL PIPE (U) ASSY	
23	062670612	2	ナベコ357-40X6	SCREW, PAN SM3.57-40X6	
24	112364001	1	ハイユハイブツギテネジ	OIL FEEDING PIPE JOINT SCREW	
25	159476000	2	ザガネ	WASHER	
26	S08951001	1	ビニルチューブクミ	OIL TUBE ASSY	
27	112351001	1	ハイユハイブネジ	OIL FEEDING PIPE SCREW	
28	159476000	2	ザガネ	WASHER	
29	155282101	1	ビニルチューブクミ	OIL TUBE ASSY	
30	112359052	2	ハイユパイプツギテネジ	SCREW	
31	159476000	4	ザガネ	WASHER	
32	S08955051	1	オイルフィルターフタ	OIL FILTER CAP	
33	062680812	4	ナベコ437-40X8	SCREW, PAN SM4.37-40X8	
34	S08956100	1	オイルフィルター	OIL FILTER	
35	S08957001	1	オイルクチ	OIL FEEDING PIPE	
36	081044070	1	OリングP44	O RING, P44	
37	S08953001	1	ビニルチューブクミ	OIL TUBE ASSMBLY	
38	112359052	1	ハイユパイプツギテネジ	SCREW	
39	159476000	2	ザガネ	WASHER	
40	S08958001	1	ロッドオイルパイプDクミ	MAIN OIL PIPE (D) ASSY	
41	062670612	1	ナベコ357-40X6	SCREW, PAN SM3.57-40X6	
42	S09316000	1	オイルフィルターD	OIL FILTE (D)	
43	062680812	4	ナベコ437-40X8	SCREW, PAN SM4.37-40X8	
44	100645003	4	ザガネ	WASHER	
45	S09125001	1	チューブガイド	OIL TUBE GUIDE	
46	062780812	1	ナベコ635-28X8	SCREW, PAN SM6.35-28X8	

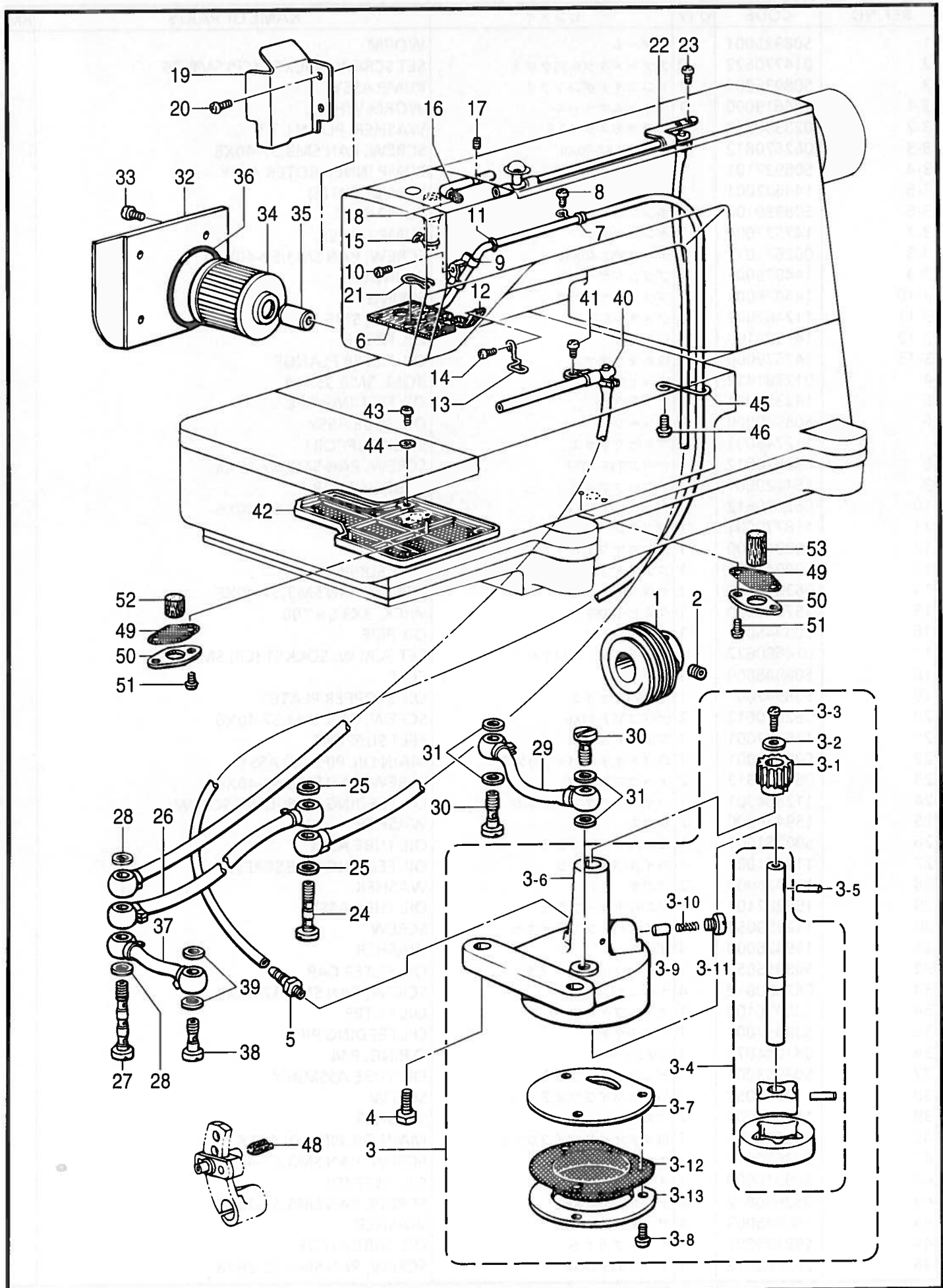

REF.NO.	CODE	Q'TY	ヒンメイ	NAME OF PARTS	RM
48	147363000	1	フェルト	FELT	
49	155294100	2	ロカモウ	OIL FILTER	
50	155295001	2	ロカモウオサエイタ	OIL FILTER FLANGE	
51	062670612	4	ナベコ357-40X6	SCREW, PAN SM3.57-40X6	
52	151927001	1	クラッチフェルト	CLUTCH FELT	
53	112754001	1	フェルト	FELT	

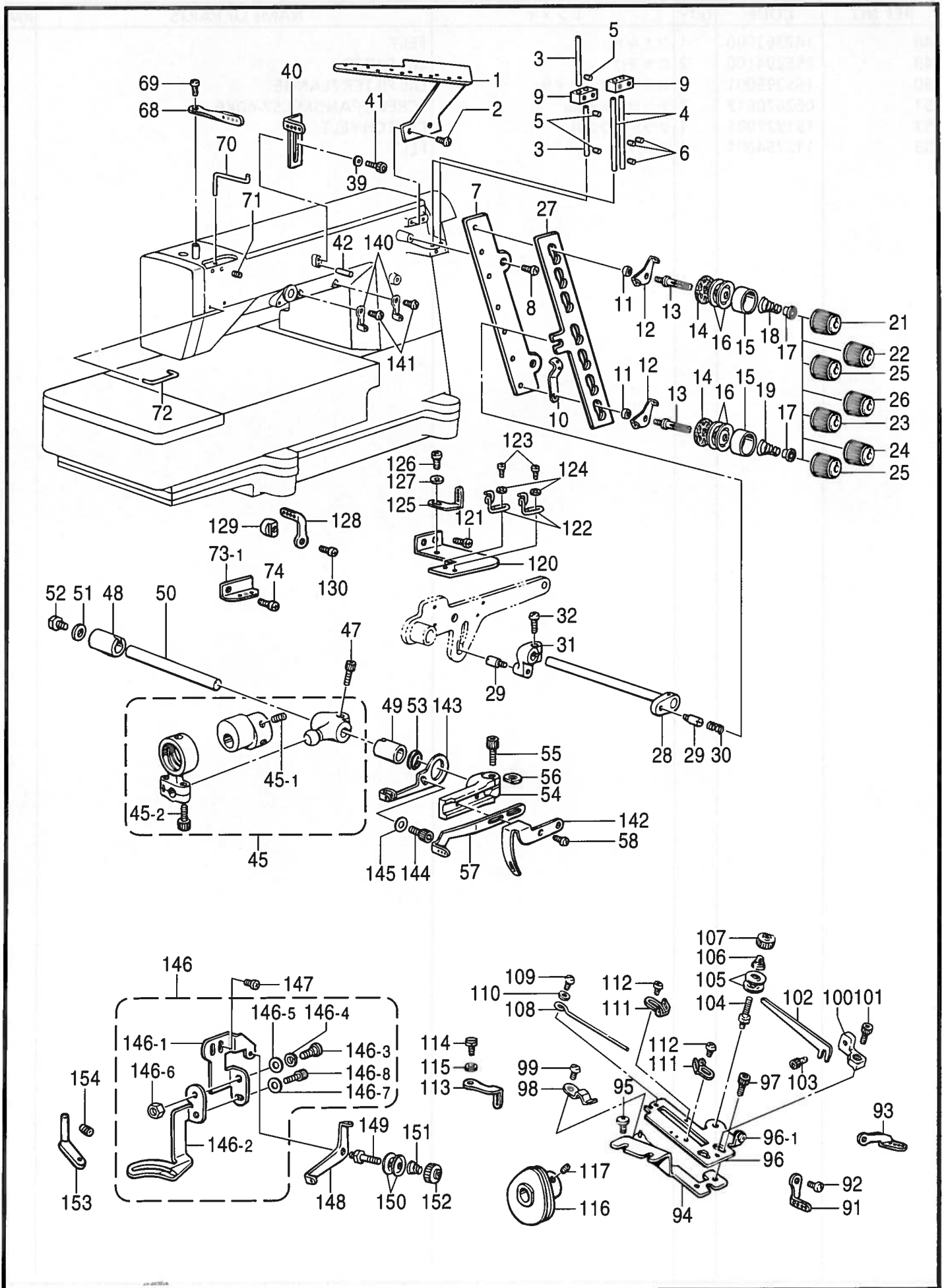

J. 糸調子関係 / Thread tension / Faderspannung / Tension du fil / Tensión del hilo

REF.NO.	CODE	Q'TY	ヒンメイ	NAME OF PARTS	RM
1	S08961101	1	シユイトアンナイ	MAIN THREAD GUIDE	
2	062680812	2	ナベコ437-40X8	SCREW, PAN SM4.37-40X8	
3	150644009	2	イトアンナイハイプS	THREAD GUIDE PIPE (S)	
4	150645009	2	イトアンナイハイプL	THREAD GUIDE PIPE, L	
5	014680422	3	アナトメネジ4.37クボミ	SET SCREW, SOCKET (CP) SM4.37	
6	014680422	3	アナトメネジ4.37クボミ	SET SCREW, SOCKET (CP) SM4.37	
7	S47207001	1	イトチヨウシダイ	TENSION BRACKET	
8	062681012	2	ナベコ437-40X10	SCREW, PAN SM4.37-40X10	
9	S47206001	2	イトアンナイハイプササエ	THREAD GUIDE PIPE SUPPORT	
10	S08963001	6	イトチヨウシダイイトアンナイ	TENSION BRACKET THREAD GUIDE	
11	S08964001	7	カンザ	SPACER	
12	110813001	7	ハリイトアンナイ	NEEDLE THREAD GUIDE	
13	159574101	7	イトチヨウシボウ	TENSION STUD	
14	110832009	7	イトチヨウシサラフェルト	TENSION DISC FELT	
15	144103009	7	イトチヨウシサラオサエ	TENSION DISC PRESSER	
16	145446001	14	イトチヨウシサラ	TENSION DISC	
17	S30564000	7	チヨウシバネウエザガネ	TENSION SPRING WASHER	
18	148851001	3	ハリイトチヨウシバネ	THREAD TENSION ADJUST SPRING	
19	144110001	4	シタルーハイトチヨウシバネ	THREAD TENSION ADJUST SPRING	
21	S30565003	1	イトチヨウシナツト	TENSION NUT, RED	
22	S30565002	1	イトチヨウシナツト	TENSION NUT, GREEN	
23	S30565003	1	イトチヨウシナツト	TENSION NUT, RED	
24	S30565002	1	イトチヨウシナツト	TENSION NUT, GREEN	
25	S30565004	2	イトチヨウシナツト	TENSION NUT, YELLOW	
26	S30565001	1	イトチヨウシナツト	TENSION NUT, LIGHT BLUE	
27	S47208001	1	イトユルメイタ	TENSION RELEASE PLATE	
28	S08966001	1	イトユルメジク	TENSION RELEASE SHAFT	
29	S08967001	2	シメネジ4.76	SCREW, SM4.76	
30	S21882001	1	イトユルメイタオシバネ	SPRING	
31	S08968001	1	イトユルメウデ	TENSION RELEASE ARM	
32	062681212	1	ナベコ437-40X12	SCREW, PAN SM4.37-40X12	
39	100645003	1	ザガネ	WASHER	
40	S12874001	1	チユウカンイトミチ	THREAD GUIDE	
41	018680822	1	アナボルト4.37X8	BOLT, SOCKET SM4.37X8	
42	143602001	1	ミゾツキピン	DOWEL PIN	
45	S08971201	1	ハリイトクリヘンシンリンクミ	NEEDLE THREAD TAKE-UP ECCENTRIC ASSY	
45-1	014770622	2	アナトメネジ6.35クボミ	SET SCREW, SOCKET (CP) SM6.35	
45-2	018401422	2	アナボルト4X14	BOLT, SOCKET M4X14	
47	018771432	1	アナボルト635-40X14	BOLT, SOCKET SM6.35-40X14	
48	155220000	1	ホジヨアツメタルR	AUTO PRESSER ARM BUSH (R)	
49	S08770000	1	ジクメタル	SHAFT BUSH	
50	S08976001	1	ハリイトクリジク	NEEDLE THREAD TAKE-UP SHAFT	
51	S00356001	1	ザガネ	WASHER	
52	S00383001	1	ボルト5.56X8	BOLT, M5.56X8	
53	155539000	1	ダストシール	DUST SEAL	
54	S08977001	1	ハリイトクリレバー	NEEDLE THREAD TAKE-UP LEVER	
55	018771432	1	アナボルト635-40X14	BOLT, SOCKET SM6.35-40X14	
56	155162001	1	スペーサ	SPACER	
57	S08978001	1	ハリイトクリ	NEEDLE THREAD TAKE-UP	
58	062681012	2	ナベコ437-40X10	SCREW, PAN SM4.37-40X10	
68	S08981001	1	ハリボウテンピン	NEEDLE BAR TAKE-UP	
69	062670612	1	ナベコ357-40X6	SCREW, PAN SM3.57-40X6	
70	S08982001	1	ハリイトウケ	NEEDLE THREAD GUIDE	
71	014680422	1	アナトメネジ4.37クボミ	SET SCREW, SOCKET (CP) SM4.37	
72	S08983001	1	アームハリイトウケ	ARM NEEDLE THREAD GUIDE	
73-1	S28438001	1	アームイトアンナイD	ARM THREAD GUIDE (D)	
74	062680812	1	ナベコ437-40X8	SCREW, PAN SM4.37-40X8	
91	S12882001	1	イトアンナイ	THREAD GUIDE	
92	062680612	1	ナベコ4.37-40X6	SCREW, PAN SM4.37-40X6	

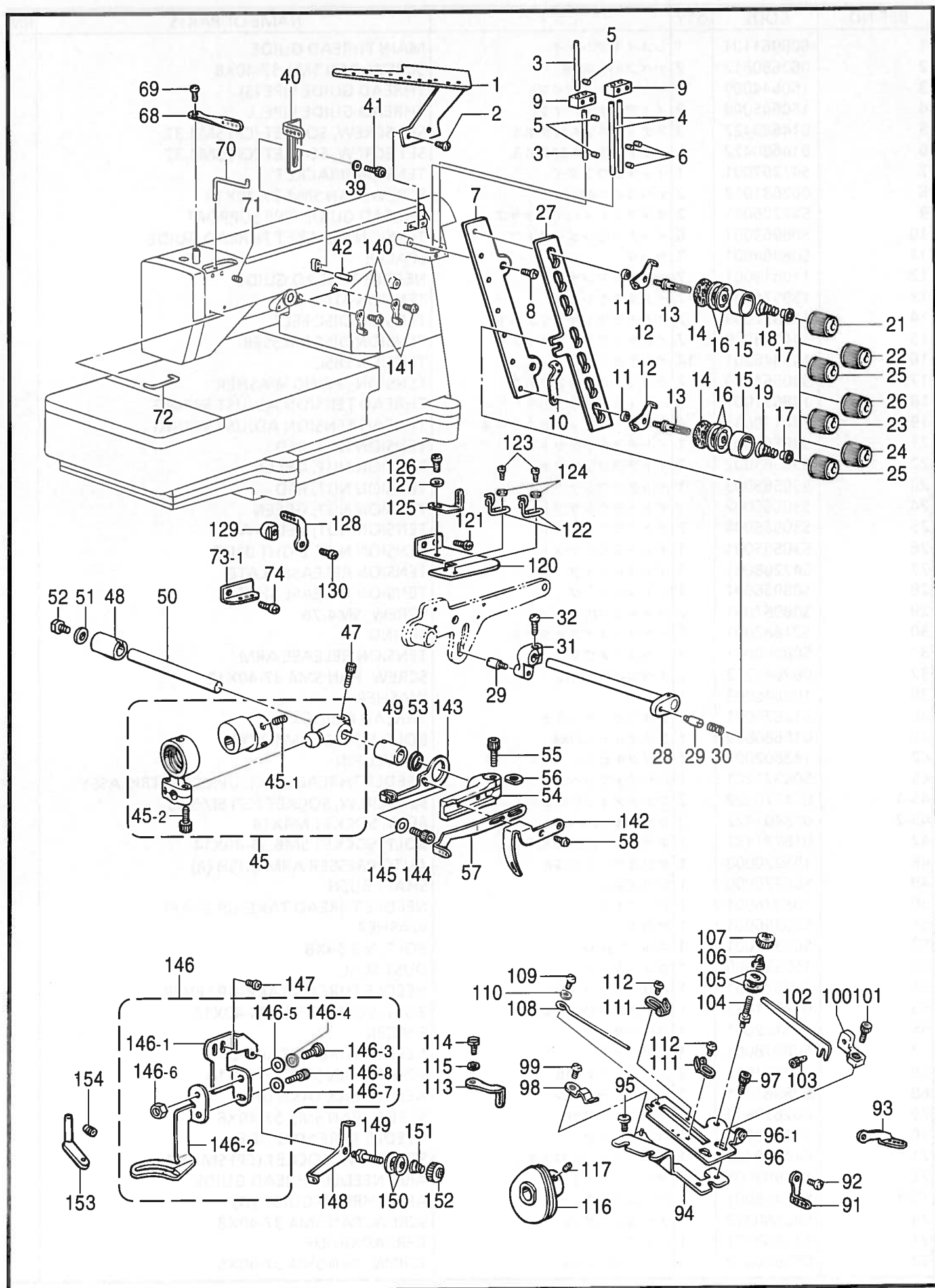

J. 糸調子関係 / Thread tension / Faderspannung / Tension du fil / Tensión del hilo

REF.NO.	CODE	Q'TY	ヒンメイ	NAME OF PARTS	RM
93	S12882001	1	イトアンナイ	THREAD GUIDE	
94	S18530001	1	テンビンドダイDクミ	LOOPER THREAD TAKE-UP BASE (D) ASSY	
95	060680712	2	バインド437-40X7	SCREW, BIND SM4.37-40X7	
96	S18532001	1	テンビンドダイUクミ	LOOPER THREAD TAKE-UP BASE (U) ASSY	
96-1	146924000	1	スレツドブツシユ	THREAD BUSH	
97	018680822	2	アナボルト4.37X8	BOLT, SOCKET SM4.37X8	
98	S18534001	1	ドダイオサエバネ	SPRING	
99	062670512	1	ナベコ357-40X5	SCREW, PAN SM3.57-40X5	
100	S18535001	1	イトオサエドダイ	THREAD PRESSER BASE	
101	154965001	1	アナボルト3.57X8	BOLT, SOCKET SM3.57X8	
102	S08992001	1	テンビンイトオサエ	LOOPER TAKE-UP PRESSER	
103	154965001	1	アナボルト3.57X8	BOLT, SOCKET SM3.57X8	
104	S08987001	1	イトチヨウシボウ	THREAD TENSION CONTROL STUD	
105	144504001	2	イトアンナイサラ	THREAD GUIDE DISC	
106	144505000	1	イトアンナイバネ	SPRING	
107	155510001	1	イトチヨウシナツト	TENSION NUT	
108	S08993101	1	テンビンイトウケ	TAKE-UP THREAD GUIDE	
109	062670512	1	ナベコ357-40X5	SCREW, PAN SM3.57-40X5	
110	105161004	1	ザガネ	WASHER	
111	S40795101	2	DLテンビンイトアンナイ	THREAD GUIDE	
112	060660416	2	バインド318-40X4	SCREW, BIND SM3.18-40X4	
113	S12882001	1	イトアンナイ	THREAD GUIDE	
114	144075001	1	ボルト3.57	BOLT, SM3.57	
115	105161004	1	ザガネ	WASHER	
116	S40572001	1	シタイトテンビクミ	LOOPER THREAD TAKE-UP ASSY	
117	014680422	2	アナトメネジ4.37クボミ	SET SCREW, SOCKET (CP) SM4.37	
120	S40570001	1	イトアンナイドダイ	THREAD GUIDE BRACKET	
121	060670812	2	バインド357-40X8	SCREW, BIND SM3.57-40X8	
122	S40571001	2	シタイトアンナイF	LOWER THREAD GUIDE (F)	
123	062670612	2	ナベコ357-40X6	SCREW, PAN SM3.57-40X6	
124	105161004	2	ザガネ	WASHER	
125	S12882001	1	イトアンナイ	THREAD GUIDE	
126	062670512	1	ナベコ357-40X5	SCREW, PAN SM3.57-40X5	
127	105161004	1	ザガネ	WASHER	
128	S12882001	1	イトアンナイ	THREAD GUIDE	
129	S25818051	1	チヨウセツレバーストツバ	STOPPER, ADJUSTING LEVER	
130	062350612	1	ナベコM3.5X6	SCREW, PAN M3.5X6	
140	S08970001	2	イトアンナイS	THREAD GUIDE, S	
141	062680612	2	ナベコ4.37-40X6	SCREW, PAN SM4.37-40X6	
142	S08979001	1	カザリイトクリ	COVERING THREAD TAKE-UP	
143	S08980001	1	カザリイトアンナイR	COVERING THREAD GUIDE (R)	
144	018680822	1	アナボルト4.37X8	BOLT, SOCKET SM4.37X8	
145	100645003	1	ザガネ	WASHER	
146	S47543001	1	カザリイトアンナイLクミ	COVERING THREAD GUIDE (L) ASSY	
146-1	S47205001	1	カザリイトアンナイLU	COVERING THREAD GUIDE(LU)	
146-2	S47215001	1	カザリイトアンナイLD	COVERING THREAD GUIDE(LD)	
146-3	S07317001	1	ダンネジ3.57	SHOULDER SCREW, SM3.57	
146-4	028050246	1	バネザガネ2-5	WASHER, SPRING 2-5	
146-5	025050232	1	ヒラザガネチユウ5	WASHER, PLAIN M 5	
146-6	106129001	1	ナツト3.57	NUT, SM3.57	
146-7	105161004	1	ザガネ	WASHER	
146-8	154965001	1	アナボルト3.57X8	BOLT, SOCKET SM3.57X8	
147	060680712	2	バインド437-40X7	SCREW, BIND SM4.37-40X7	
148	S08986001	1	カザリイトアンナイ	COVERING THREAD GUIDE	
149	S08987001	1	イトチヨウシボウ	THREAD TENSION CONTROL STUD	
150	144504001	2	イトアンナイサラ	THREAD GUIDE DISC	
151	144505000	1	イトアンナイバネ	SPRING	
152	155510001	1	イトチヨウシナツト	TENSION NUT	
153	S08988001	1	ハリドメカザリイトアンナイ	NEEDLE CLAMP THREAD GUIDE	
154	146427001	1	アナトメネジ3.18クボミ	SET SCREW, SOCKET (CP) SM3.18	





## Z. 付属品関係 / Accessories / Zubehör / Accessoires / Accesorios

REF.NO.	CODE	Q'TY	ヒンメイ	NAME OF PARTS	RM
1	S08715118	1	ミシンハリ110クミ	NEEDLE ASSY, #110	
4	101572101	1	ネジマワシ5.5X190	SCREW DRIVER, 5.5X190	
5	118837001	1	ネジマワシ3.4X70	SCREW DRIVER, 3.4X70	
6	S01943001	1	6カクボウネジマワシ1.6	SCREW DRIVER, HEX. 1.6	
7	146049001	1	6カクボウスハナ2	HEXAGONAL WRENCH, 2	
8	142721001	1	6カクボウスハナ3	HEXAGONAL WRENCH, 3	
10	150335001	1	6カクボウスハナ5	HEXAGONAL WRENCH, 5	
13	105343001	1	メガネレンチ8X9	WRENCH, 8X9	
18	117466000	1	ピンセット	PINCETTE	
19	S06701000	1	ポリオイラークミ	POLY OILER ASSY	
20	145277205	1	オイルタンク	OIL TANK	
26	149247001	1	クサリクミ	CHAIN ASSY	
35	147919051	4	ボウシンゴム	RUBBER CUSHION	
36	S09001101	1	クサリガイド	CHAIN GUIDE	
40	S06704001	1	シリコンオイル	SILICONE OIL	
41	140759000	1	ジヨーゴ	FUNNEL	
42	144224001	1	トウブカバー	HEAD COVER	
43	S09002009	1	ベルトカバー	BELT COVER	
44	102424004	2	シメネジ4.37	SCREW, M4.37	
90	S47214001	1	イトタテダイクミ7DTHF	COTTON STAND ASSY, 7DTHF	
90-1	150180001	7	ウケザラ	SPOOL STAND BASE	
90-2	150182000	7	スプールマット	SPOOL MAT	
90-3	126863001	7	スプールクツシヨン	SPOOL CUSHION	
90-4	S02775001	1	ハイブネジセットA	PIPE SCREW SET, A	
90-4-1	150206002	1	ヒラザガネ16	WASHER, PLAIN 16	
90-4-2	S38648001	1	6カクナツU5/8	NUT, U5/8-28	
90-5	S04109001	1	イトアンナイササエボウ	THREAD GUIDE SUPPORT BAR	
90-6	142999101	1	イトアンナイ5	THREAD GUIDE, 5	
90-7	S40640001	1	コラムパイプキヤツブツキ	COLUMN PIPE WITH CAP	
90-7-1	150174000	1	コラムキヤツブ	COLUMN CAP	
90-8	156112003	1	コラムハイブD	COLUMN PIPE, D	
90-9	150173003	1	コラムジョイント	COLUMN JOINT	
90-10	S21798001	7	スプールネジセット	SPOOL SCREW SET	
90-10-1	150179002	7	スプールジクB	SPOOL SHAFT, B	
90-10-2	028050246	7	バネザガネ2-5	WASHER, SPRING 2-5	
90-10-3	021500106	7	1シュナツト5	NUT, 1 M5	
90-11	150185009	1	イトアンナイホルダー	THREAD GUIDE HOLDER	
90-12	138843001	1	ササエボウツギテ	JOINT	
90-13	150188009	1	スプールホルダーササエA	SPOOL HOLDER SUPPORT, A	
90-14	150194009	1	スプールホルダーササエB	SPOOL HOLDER SUPPORT, B	
90-15	S02778002	1	スプールホルダー2	SPOOL HOLDER, 2	
90-16	S02786002	1	スレツドハンガークミ2	THREAD HANGER ASSY, 2	
90-16-1	S02787002	1	スレツドハンガー2	THREAD HANGER, 2	
90-16-2	150183000	2	イトカケハンガーダイ	THREAD HANGER BASE	
90-16-3	142990001	2	スレツドブッシュ	THREAD BUSH	
90-17	S02779009	2	スプールホルダー3	SPOOL HOLDER, 3	
90-18	S02788009	2	スレツドハンガークミ3	THREAD HANGER ASSY, 3	
90-18-1	S02789009	2	スレツドハンガー3	THREAD HANGER, 3	
90-18-2	150183000	6	イトカケハンガーダイ	THREAD HANGER BASE	
90-18-3	142990001	6	スレツドブッシュ	THREAD BUSH	
90-19	S40641001	1	スプールジクネジセットA	SPOOL SCREW SET, A	
90-19-1	021500106	4	1シュナツト5	NUT, 1 M5	
90-19-2	S37038001	1	ナベコヒラザ5X14	SCREW, PAN (S/P WASHER) M5X14	
90-19-3	S37037001	1	ナベコヒラザ5X32	SCREW, PAN (S/P WASHER) M5X32	
90-19-4	062501406	2	ナベコ5X14	SCREW, PAN M5X14	
90-20	S40642001	2	スプールジクネジセットB	SPOOL SHAFT SCREW SET, B	
90-20-1	021500106	4	1シュナツト5	NUT, 1 M5	
90-20-2	S37038001	2	ナベコヒラザ5X14	SCREW, PAN (S/P WASHER) M5X14	
90-20-3	S37037001	2	ナベコヒラザ5X32	SCREW, PAN (S/P WASHER) M5X32	



Z. 付属品関係 / Accessories / Zubehör / Accessoires / Accesorios

REF.NO.	CODE	Q'TY	ヒンメイ	NAME OF PARTS	RM
90-21	S40643001	1	ホルダーツギテネジセット	HOLDER JOINT SCREW SET	
90-21-1	014060632	2	アナトメ6X6クボミ	SET SCREW, SOCKET (CP) M6X6	
90-21-2	021500106	1	1シユナツト5	NUT, 1 M5	
90-21-3	S37037001	1	ナベコヒラザ5X32	SCREW, PAN (S/P WASHER) M5X32	
90-22	S40644001	2	ホルダーツギテネジセット	HOLDER JOINT SCREW SET	
90-22-1	021500106	2	1シユナツト5	NUT, 1 M5	
90-22-2	031452206	2	マルモク45X22	WOOD SCREW, ROUND M4.5X22	
90-22-3	062501006	2	ナベコ5X10	SCREW, PAN M5X10	
109	S02747101	4	イトカケバネ	SPRING	
121	S47542001	1	イトトオシボウ	THREADING BAR	
130	S11561001	2	トウブウケイタ	HEAD SPOOL PLATE	
131	S11562001	4	カクネマルアタマボルト	BOLT	
132	100666002	4	マルモクネジ5.5X20	WOOD SCREW, ROUND M5.5X20	
133	025080336	12	ヒラザガネダイ8	WASHER, PLAIN L 8	
134	028080242	8	バネザガネ2-8	WASHER, SPRING 2-8	
135	021080106	12	ナツト1シユ8	NUT, 1 M8	
136	032461606	2	+マルモクネジ4.5X16 <オプションパーツ>	WOOD SCREW, ROUND M4.5X16 <OPTION PARTS>	
22	147893009	1	オサエアゲフミイタ	TREADLE PEDAL	
23	021400106	2	ナツト1シユ4	NUT, 1 M4	
24	062401406	2	ナベコ4X14	SCREW, PAN M4X14	
25	116016001	2	ヘタルトメ	PEDAL STOPPER	

索引 / INDEX / VERZEICHNIS  
/ INDEX / INDICE

CODE	REF.NO.	Page
S00017001	A - 102	4
S00075000	A - 90-3	2
S00313009	A - 24	2
	A - 123	4
S00356001	J - 51	24
S00383001	J - 52	24
S00879001	C - 25	8
S01295001	C - 40-8	8
S01943001	Z - 6	28
S02606000	A - 5	2
S02747101	Z - 109	30
S02775001	Z - 90-4	28
S02778002	Z - 90-15	28
S02779009	Z - 90-17	28
S02786002	Z - 90-16	28
S02787002	Z - 90-16-1	28
S02788009	Z - 90-18	28
S02789009	Z - 90-18-1	28
S03421001	G - 13	18
S03704002	B - 50	6
	D - 46	12
	F - 28	16
S04109001	Z - 90-5	28
S06701000	Z - 19	28
S06704001	Z - 40	28
S07317001	A - 90-6	2
	J - 146-3	26
S08467000	D - 70	12
S08627001	A - 2	2
S08628000	A - 3	2
S08631000	A - 16	2
S08633101	A - 26	2
S08642001	A - 38	2
S08646100	A - 40	2
S08651001	A - 42	2
S08652000	A - 43	2
S08653001	A - 48	2
S08665001	A - 100	4
S08667001	A - 105	4
S08668001	A - 108	4
S08670000	A - 116	4
S08671101	A - 119	4
S08672000	A - 120	4
S08673000	A - 128	4
S08674000	A - 138	4
S08675000	A - 139	4
S08682001	B - 3	6
S08683000	B - 4	6
S08684101	B - 6	6
S08685001	B - 6-1	6
S08686101	B - 6-2	6
S08687001	B - 8	6
S08688051	B - 9	6
S08692101	B - 16	6
S08693001	B - 16-1	6
S08694001	B - 16-2	6
S08695001	B - 16-4-1	6
S08696000	B - 23	6
S08697000	B - 24	6
S08698001	B - 25	6
S08715018	B - 31	6
S08715118	Z - 1	28
S08716301	B - 35	6

CODE	REF.NO.	Page
S08750001	B - 42	6
S08751001	B - 44	6
S08752001	B - 46	6
S08753000	B - 48	6
S08754000	B - 49	6
	F - 27	16
S08755101	B - 51	6
S08767001	C - 1	8
S08768001	C - 2	8
S08769001	C - 6	8
S08770000	C - 12	8
	F - 7	16
	J - 49	24
S08771001	C - 14	8
S08774001	C - 18	8
S08775000	C - 28	8
S08776001	C - 30	8
S08777001	C - 31	8
S08870001	D - 8	10
S08871001	D - 10	10
S08872001	D - 20	10
S08873001	D - 20-1	10
S08876000	D - 36	10
S08877001	D - 44	12
S08878001	D - 54	12
S08879001	D - 57	12
S08880001	D - 58	12
S08881101	D - 64	12
S08889101	E - 1	14
S08890001	E - 1-1	14
S08891001	E - 5	14
S08892001	E - 8	14
S08895002	E - 10	14
S08896101	E - 11	14
S08897001	E - 11-1	14
S08898000	E - 13	14
S08899001	E - 14	14
S08900000	E - 16	14
S08903000	E - 17	14
S08904000	E - 20	14
S08910001	F - 5	16
S08911000	F - 8	16
S08914001	F - 20	16
S08915001	F - 23	16
S08917000	F - 26	16
S08918001	F - 29	16
S08919001	F - 32	16
S08920001	F - 33	16
S08921101	F - 35	16
S08925000	G - 1-2	18
S08926201	G - 4	18
S08927001	G - 10	18
S08928001	G - 15	18
S08931001	G - 19	18
S08932000	G - 20	18
S08933051	G - 24	18
S08935001	H - 1	20
S08936201	H - 3	20
S08937101	H - 3-4	20
S08939100	H - 3-6	20
S08940000	H - 6	20
S08943000	H - 12	20
S08944001	H - 13	20

CODE	REF.NO.	Page
S08945001	H - 16	20
S08946000	H - 18	20
S08947001	H - 19	20
S08948001	H - 22	20
S08951001	H - 26	20
S08953001	H - 37	20
S08955051	H - 32	20
S08956100	H - 34	20
S08957001	H - 35	20
S08958001	H - 40	20
S08961101	J - 1	24
S08963001	J - 10	24
S08964001	J - 11	24
S08966001	J - 28	24
S08967001	E - 19	14
	J - 29	24
S08968001	J - 31	24
S08970001	J - 140	26
S08971201	J - 45	24
S08976001	J - 50	24
S08977001	J - 54	24
S08978001	J - 57	24
S08979001	J - 142	26
S08980001	J - 143	26
S08981001	J - 68	24
S08982001	J - 70	24
S08983001	J - 72	24
S08986001	J - 148	26
S08987001	J - 104	26
	J - 149	26
S08988001	J - 153	26
S08992001	J - 102	26
S08993101	J - 108	26
S09001101	Z - 36	28
S09002009	Z - 43	28
S09120001	B - 16-3	6
S09121001	B - 41	6
S09123101	A - 34	2
S09124001	B - 38	6
S09125001	H - 45	20
S09251001	F - 35-1	16
S09316000	H - 42	20
S10774001	A - 14	2
S11561001	Z - 130	30
S11562001	Z - 131	30
S11588001	F - 25	16
S11589000	F - 37	16
S12725101	B - 11	6
S12874001	J - 40	24
S12882001	J - 91	24
	J - 93	26
	J - 113	26
	J - 125	26
	J - 128	26
S13385001	B - 39	6
S13809001	G - 6	18
S14621001	B - 1-2	6
S14622001	E - 1-2	14
S14623001	E - 11-2	14
S16249001	D - 80	12
S16498001	D - 1-1	10
S18530001	J - 94	26
S18532001	J - 96	26

索引 / INDEX / VERZEICHNIS  
/ INDEX / INDICE

CODE	REF.NO.	Page
S18534001	J - 98	26
S18535001	J - 100	26
S20118151	C - 40-2	8
S21798001	Z - 90-10	28
S21882001	J - 30	24
S23359001	D - 22	10
	D - 27	10
S25818051	J - 129	26
S28438001	J - 73-1	24
S28802001	A - 90	2
S28803001	A - 90-1	2
S28804001	A - 90-2	2
S28809201	A - 20	2
S28810051	A - 15	2
S28957001	B - 1	6
S28958001	B - 1-1	6
S30086001	B - 16-4	6
S30564000	J - 17	24
S30565001	J - 26	24
S30565002	J - 22	24
	J - 24	24
S30565003	J - 21	24
	J - 23	24
S30565004	J - 25	24
S31012001	C - 19	8
S31013001	C - 20	8
S37037001	Z - 90-19-3	28
	Z - 90-20-3	28
	Z - 90-21-3	30
S37038001	Z - 90-19-2	28
	Z - 90-20-2	28
	Z - 90-4-2	28
S38648001	D - 34	10
S39086001	A - 12	2
S40532101	A - 115	4
S40533001	C - 40-6	8
S40546001	F - 1	16
S40567001	J - 120	26
S40570001	J - 122	26
S40572001	J - 116	26
S40640001	Z - 90-7	28
S40641001	Z - 90-19	28
S40642001	Z - 90-20	28
S40643001	Z - 90-21	30
S40644001	Z - 90-22	30
S40795101	J - 111	26
S40960051	A - 30	2
S40961001	A - 32	2
S47183001	B - 30	6
S47185001	B - 40	6
S47186001	B - 53	6
S47187001	C - 40	8
S47190001	C - 40-3	8
S47191001	C - 40-4	8
S47192001	C - 40-5	8
S47193001	C - 40-7	8
S47195001	D - 73	12
S47196001	D - 74	12
S47197001	F - 14-4	16
S47198001	F - 14-5	16
S47199001	F - 14-6	16
S47200001	F - 10	16
S47201001	G - 1	18

CODE	REF.NO.	Page
S47202001	G - 1-1	18
S47204001	G - 26	18
S47205001	J - 146-1	26
S47206001	J - 9	24
S47207001	J - 7	24
S47208001	J - 27	24
S47209001	A - 41	2
S47210001	A - 73	2
S47211001	A - 33	2
S47212001	A - 36	2
S47213001	C - 41	8
S47214001	Z - 90	28
S47215001	J - 146-2	26
S47542001	Z - 121	30
S47543001	J - 146	26
014060632	Z - 90-21-1	30
014680422	B - 54	6
	G - 23	18
	J - 5	24
	J - 6	24
	J - 71	24
	J - 117	26
014680622	B - 43	6
	B - 45	6
	F - 21	16
	G - 1-1-1	18
	H - 17	20
014760622	B - 15	6
	C - 26	8
014770622	B - 2	6
	B - 5	6
	B - 7	6
	B - 13	6
	B - 50-1	6
	D - 46-1	12
	E - 9	14
	E - 12	14
	E - 15	14
	F - 24	16
	F - 28-1	16
	G - 13-1	18
	G - 16	18
	H - 2	20
	J - 45-1	24
014780622	D - 43	12
	E - 2	14
017781412	D - 67	12
	H - 4	20
018060822	A - 13	2
018081622	A - 140	4
018401422	J - 45-2	24
018680822	J - 41	24
	J - 97	26
	J - 144	26
018681022	B - 36	6
	B - 52	6
018771432	C - 10	8
	D - 7	10
	D - 50	12
	D - 54-2	12
	D - 57-1	12
	E - 7	14
	F - 2	16

CODE	REF.NO.	Page
018771432	F - 12	16
	G - 5	18
	J - 47	24
	J - 55	24
021080106	Z - 135	30
021400106	Z - 23	30
021500106	Z - 90-10-3	28
	Z - 90-19-1	28
	Z - 90-20-1	28
	Z - 90-21-2	30
	Z - 90-22-1	30
025030232	A - 90-5	2
025050232	A - 90-8	2
	J - 146-5	26
025080132	A - 35	2
025080336	Z - 133	30
025350332	H - 3-2	20
025680133	A - 83	2
025770232	D - 66	12
028050246	A - 90-7	2
	J - 146-4	26
	Z - 90-10-2	28
028080242	Z - 134	30
031452206	Z - 90-22-2	30
032461606	Z - 136	30
047502242	D - 63	12
048040342	D - 9	10
048150143	D - 1-12	10
060660416	J - 112	26
060670512	A - 90-10	4
060670812	J - 121	26
060680512	D - 81	12
060680712	A - 91	4
	A - 106	4
	C - 3	8
	J - 95	26
	J - 147	26
060681612	A - 45	2
062350612	J - 130	26
062401406	Z - 24	30
062501006	Z - 90-22-3	30
062501406	Z - 90-19-4	28
062630612	F - 34	16
062660412	F - 4	16
062660512	A - 90-4	2
	D - 1-8	10
062660712	D - 54-1	12
062670512	J - 99	26
	J - 109	26
	J - 126	26
062670612	A - 136	4
	B - 21	6
	H - 8	20
	H - 10	20
	H - 14	20
	H - 20	20
	H - 23	20
	H - 41	20
	H - 51	22
	J - 69	24
	J - 123	26
062670812	C - 42	8
	D - 19	10

索引 / INDEX / VERZEICHNIS  
/ INDEX / INDICE

CODE	REF.NO.	Page
062670812	E - 25	14
	H - 3-3	20
062671012	H - 3-8	20
062671212	C - 40-1	8
062680612	A - 47	2
	E - 4	14
	J - 92	24
	J - 141	26
062680812	A - 27	2
	A - 101	4
	B - 37	6
	H - 33	20
	H - 43	20
	J - 2	24
	J - 74	24
062681012	A - 4	2
	A - 21	2
	A - 111	4
	D - 31	10
	D - 35	10
	G - 27	18
	J - 8	24
	J - 58	24
062681212	J - 32	24
062681412	A - 51	2
	C - 29	8
	G - 25	18
062681612	A - 17	2
062711012	B - 10	6
062780812	H - 46	20
072600000	E - 22	14
081003670	D - 12	10
081007670	G - 21	18
081014670	A - 6	2
081032870	E - 18	14
081044070	H - 36	20
081046870	B - 26	6
100025002	D - 1-17	10
100032004	A - 31	2
100064005	B - 16-4-2	6
100251001	D - 5	10
100294002	D - 61	12
100645003	A - 80	2
	D - 30	10
	H - 44	20
	J - 39	24
	J - 145	26
100666002	Z - 132	30
101482001	G - 3	18
101572101	Z - 4	28
101706001	A - 104-1	4
	D - 40	10
102424004	Z - 44	28
102630001	B - 22	6
104449009	A - 22	2
104450109	A - 60	2
	A - 130	4
104464001	B - 12	6
104908004	F - 15	16
105161004	J - 110	26
	J - 115	26
	J - 124	26
	J - 127	26

CODE	REF.NO.	Page
105161004	J - 146-7	26
105234003	A - 52	2
	A - 112	4
105343001	Z - 13	28
106129001	A - 90-9	4
	J - 146-6	26
107153001	B - 17	6
107272002	D - 45	12
107407003	A - 109	4
	A - 117	4
	A - 121	4
108520009	A - 23	2
108960002	A - 74	2
109203001	A - 142	4
	D - 62	12
110161006	F - 31	16
	G - 8	18
110197001	G - 22	18
110641002	A - 141	4
110704001	F - 3	16
110793001	C - 7	8
110813001	J - 12	24
110832009	J - 14	24
112351001	H - 27	20
112359052	H - 30	20
	H - 38	20
112364001	H - 24	20
112467002	H - 3-11	20
112743001	H - 7	20
112754001	H - 53	22
113431002	D - 52	12
114294001	E - 21	14
114985001	A - 46	2
116016001	Z - 25	30
117466000	Z - 18	28
117516001	A - 122	4
117517003	D - 1-16	10
117934009	A - 19	2
118770001	H - 11	20
118837001	Z - 5	28
118853001	B - 14	6
120990001	F - 35-1-1	16
123185001	A - 37	2
	A - 39	2
126863001	Z - 90-3	28
138843001	Z - 90-12	28
140063001	A - 107	4
140165001	D - 1-3	10
140176001	D - 1-15	10
140205001	D - 49	12
140207001	D - 21	10
140209001	D - 23	10
140210001	D - 24	10
140217001	D - 28	10
140313001	F - 35-2	16
140326009	D - 4	10
140327001	D - 14	10
	F - 9	16
140407001	C - 22	8
140759000	Z - 41	28
141183000	A - 103	4
141208001	C - 23	8
141728001	C - 21	8





CODE	REF.NO.	Page
142274009	A - 49	2
142359001	H - 5	20
142721001	Z - 8	28
142990001	Z - 90-16-3	28
	Z - 90-18-3	28
142999101	Z - 90-6	28
143311001	E - 23	14
143312000	E - 24	14
143325001	C - 5	8
143564001	D - 51	12
143565001	D - 53	12
143602001	J - 42	24
144053001	D - 1-9	10
144055001	D - 1-10	10
144075001	J - 114	26
144103009	J - 15	24
144110001	J - 19	24
144224001	Z - 42	28
144504001	J - 105	26
	J - 150	26
144505000	J - 106	26
	J - 151	26
144619000	H - 3-1	20
144622001	H - 3-5	20
144875001	H - 3-9	20
144876001	H - 3-10	20
145277205	Z - 20	28
145446001	J - 16	24
145472001	C - 24	8
145663001	D - 1-2	10
145688000	B - 20	6
145737001	H - 21	20
146049001	Z - 7	28
146315009	A - 125	4
146401001	D - 1-4	10
146402001	D - 1-5	10
146403001	D - 1-6	10
146404001	D - 1-7	10
146427001	B - 30-1	6
	J - 154	26
146457001	A - 135	4
146528102	D - 1	10
146529001	D - 1-11	10
146530001	D - 1-13	10
146531001	D - 1-14	10
146532001	D - 2	10
146533001	D - 6	10
146538101	D - 13	10
146539000	D - 15	10
146540000	D - 16	10
146544000	D - 20-2	10
146547000	D - 41	10
	G - 17	18
146548101	D - 42	10
146554001	D - 25	10
146555001	D - 26	10
146556001	D - 55	12
146559001	D - 59	12
146560101	D - 60	12
146563001	D - 65	12
146586009	A - 50	2
	A - 110	4
	A - 129	4

索引 / INDEX / VERZEICHNIS  
/ INDEX / INDICE

CODE	REF.NO.	Page
146624101	F - 22	16
146741000	D - 39	10
146924000	J - 96-1	26
147318000	D - 3	10
147363000	H - 48	22
147527000	H - 3-7	20
147528100	H - 3-12	20
147529000	H - 3-13	20
147893009	Z - 22	30
147919051	Z - 35	28
148084001	A - 29	2
148196000	G - 11	18
148197000	G - 12	18
148372001	C - 4	8
148425001	F - 1-1	16
	F - 22-1	16
148834001	D - 56	12
	G - 15-1	18
	G - 18	18
148847001	F - 30	16
	G - 7	18
148851001	J - 18	24
149247001	Z - 26	28
150173003	Z - 90-9	28
150174000	Z - 90-7-1	28
150179002	Z - 90-10-1	28
150180001	Z - 90-1	28
150182000	Z - 90-2	28
150183000	Z - 90-16-2	28
	Z - 90-18-2	28
150185009	Z - 90-11	28
150188009	Z - 90-13	28
150194009	Z - 90-14	28
150206002	Z - 90-4-1	28
150335001	Z - 10	28
150644009	J - 3	24
150645009	J - 4	24
151059001	A - 137	4
151267001	A - 118	4
151429001	H - 9	20
151927001	H - 52	22
152718001	B - 18	6
153484001	D - 11	10
153675001	A - 44	2
153734001	E - 3	14
154596000	C - 27	8
154841009	A - 61	2
154886001	E - 6	14
154956001	C - 9	8
154957001	C - 11	8
154965001	D - 71	12
	J - 101	26
	J - 103	26
	J - 146-8	26
155144001	D - 17	10
155145000	D - 18	10
155151000	D - 29	10
155162001	J - 56	24
155175051	D - 68	12
155176001	D - 69	12
155177100	D - 32	10
155178001	D - 33	10
155220000	C - 8	8

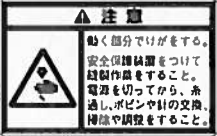
CODE	REF.NO.	Page
155220000	J - 48	24
155282101	H - 29	20
155294100	H - 49	22
155295001	H - 50	22
155510001	J - 107	26
	J - 152	26
155539000	B - 47	6
	C - 13	8
	F - 6	16
	J - 53	24
156112003	Z - 90-8	28
157840000	H - 15	20
159150009	A - 7	2
159476000	H - 25	20
	H - 28	20
	H - 31	20
	H - 39	20
159574101	J - 13	24
183893001	A - 104	4

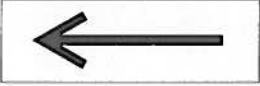
Wa. 警告ラベル / Warning labels / Warnschilder / Etiquettes d'avertissement  
/ Etiquetas de advertencia

警告ラベル / Warning labels	品名 / Name of parts	Size(mm)	Code
	操作注意ラベル・和	40×64	S38350-001
	Label, operation Eng.	40×64	S38349-001
	矢印マーク Mark, arrow	10×30	S37058-001
	アースマーク Mark, grounding	φ 12	S37060-001









LIBRO DE REFERENCIA DE PIEZAS  
LIVRE DES PIÈCES  
TELEKATALÓG  
PARTS BOOK  
KATAKALOG

Brother International Corporation

235 West 57th Street, New York, NY 10019, USA

Brother (China) Service Center, No. 1000, Zhongyuan Road, Beijing 100000, China

Brother (India) Service Center, No. 100, Connaught Place, New Delhi 110028, India

brother®

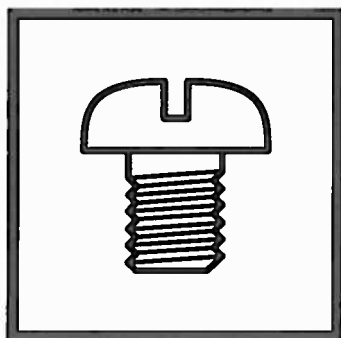

パーツブック  
PARTS BOOK  
TEILEKATALOG  
LIVRE DES PIECES  
LIBRO DE REFERENCIA DE PIEZAS

**ブラザー工業株式会社**

BROTHER INDUSTRIES, LTD.

〒467-8562 名古屋市瑞穂区河岸1丁目1番1号 TEL(052)824-2392

Printed in Japan / Gedruckt in Japan / Imprimé au Japon / Impreso en Japón

118-261  
S95261-011  
1998.9 B ①