

Please clarify Ref. No. and  
Parts No. as well as parts name  
When you place an order.

**EF4-B955**

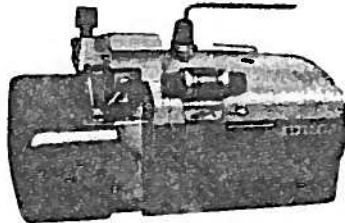

**EF4-B953**

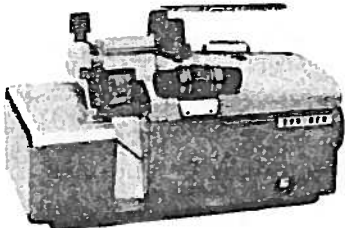

I 1010007

I N D E X

Parts. No.	Ref. No.	Remark	Parts. No.	Ref. No.	Remark	Parts. No.	Ref. No.	Remark	Parts. No.	Ref. No.	Remark
003670-6-14	A-12		100402-0-03	F-15		107556-0-02	D-20		110669-0-00	B-21	
018401-2-22	C-23		100522-0-01	B-5		108721-0-01	F-30		110670-0-00	B-27	
021660-0-03	F-18		100541-0-01	A-17		"	G-24		110671-0-00	B-24	
033352-5-02	A-69		100541-0-03	F-2		108960-0-03	E-63		"	B-26	
041570-2-03	A-72		102438-0-02	A-42		109203-0-01	A-52		110672-0-00	B-25	
100010-0-01	A-2		102571-0-01	D-51		109405-0-01	A-30		110673-0-00	B-23	
100013-0-01	E-18		"	E-42		109814-0-01	F-29		110674-0-00	B-29	
100013-0-02	A-23		"	G-29		"	G-23		110682-0-00	B-18	
"	A-25		102707-0-01	F-6		110614-0-01	A-19		110683-0-00	B-17	
100013-0-03	B-34		102843-0-01	A-11		110616-0-01	A-14		110684-0-01	B-9,10	
"	C-14		"	A-21		110617-0-01	A-15		110685-0-01	B-9	
100032-0-01	B-45		"	F-9		110618-0-01	A-16		110686-0-01	B-10	
100062-0-04	C-50		102843-0-02	B-31		110621-0-01	A-18		"	D-42	
100080-0-02	E-27		104450-0-01	A-48		110623-0-01	A-34		110687-0-01	B-11	
"	E-30		104559-0-02	B-12		110624-0-01	A-35		110688-0-01	B-7	
"	E-37		"	E-56		110625-0-01	A-38		110689-0-00	B-8	
"	F-23		104649-0-01	C-46		110626-0-01	A-39		110690-0-01	B-4	
"	F-25		104651-0-01	F-13		110627-0-01	A-20		110691-0-01	B-2	
"	G-36		104869-0-02	D-50		110628-0-01	A-22		110692-0-01	B-6	
100080-0-03	C-38		105034-0-02	C-20		110629-0-00	A-26		110693-0-01	B-1	
"	E-50		105123-0-01	D-34		110630-0-01	A-27		110694-0-09	B-3	
100086-0-03	D-2		"	F-45		110631-0-00	A-28		"	G-8	
"	D-8		105205-0-01	F-38		110632-0-00	A-29		110696-0-01	B-41	
"	F-48		105228-0-01	G-21		110633-0-01	A-43~A-47		110697-0-01	B-39	
100088-0-02	B-16		105234-0-01	C-33		110634-0-01	A-43		110698-0-01	B-37	
100105-0-01	G-40		"	E-53		110635-0-01	A-44		110699-0-01	B-35	
100105-0-02	E-29		105248-0-01	F-41		110636-0-01	A-31		110700-0-01	C-15~C-18	
100137-0-02	B-40		105904-0-01	C-29		110637-0-01	A-32		110701-0-01	C-16	
100137-0-03	A-45		"	E-58		110638-0-00	A-24		110703-0-01	C-15	
100137-0-04	F-11		106129-0-01	A-47		110639-0-01	A-56		110704-0-01	C-19	
100185-0-03	A-59		"	F-43		110641-0-01	A-53		110705-0-00	C-12	
100242-0-01	A-5		106556-0-01	D-37		110643-0-01	A-58		110706-0-01	C-13	
100242-0-04	F-17		106568-0-01	A-63		110644-0-01	A-49		110707-0-01	C-11	
100257-0-07	A-61		106764-0-01	B-36		110649-0-01	A-73		110708-0-01	C-7,9,10	
100257-0-08	C-52		"	E-3		110651-0-01	A-74		110709-0-01	C-7	
"	F-7		106766-0-01	B-19		110654-0-01	A-60		110710-0-01	C-9	
100287-0-03	A-4		107086-0-01	F-3		110655-0-01	A-62		110711-0-01	C-10	
"	C-8		107219-0-01	E-12		110656-0-01	A-65		110712-0-01	C-5	
100287-0-04	C-2		107244-0-01	B-22		110657-0-01	A-64		110714-0-01	C-6	
100368-0-02	A-37		107263-0-01	A-36		110662-0-01	B-20		110715-0-01	C-1	
"	B-28		107351-0-01	B-38		110663-0-00	B-43		110716-0-01	C-34~C-39	
"	C-30		107385-0-01	D-48		110664-0-00	B-46		"	E-47,48,51	
"	D-22		107407-0-02	A-66		110665-0-01	B-12,13		110717-0-01	C-35	
"	D-26		107526-0-01	C-26		110666-0-00	B-13		"	E-47	
100368-0-03	E-54		"	C-45		110668-0-01	B-15		110718-0-01	C-34	

## INDEX

Parts. No.	Ref. No.	Remark	Parts. No.	Ref. No.	Remark	Parts. No.	Ref. No.	Remark	Parts. No.	Ref. No.	Remark
110718-0-01	E-51		110765-0-01	D-7		110807-0-01	F-21		111431-0-01	D-18	
110719-0-01	C-32		110766-0-01	D-11		"	G-35		111432-0-01	"	
110720-0-01	C-37		110767-0-01	D-12		110808-0-01	E-28		111433-0-01	"	
"	E-49		110768-0-00	D-13		"	G-39		111434-0-01	"	
110721-0-01	E-57		110769-0-01	D-9,10		110809-0-01	E-52		111435-0-01	"	
110722-0-01	C-28		110770-0-01	D-9		110810-0-01	E-61		111436-0-01	E-16	
"	E-59		110771-0-01	D-10		110811-0-01	E-62		111443-0-01	C-4	
110723-0-00	C-27		110772-0-01	D-14		110813-0-01	F-33		"	C-44	
"	E-60		110773-0-01	D-15		"	G-27		111450-0-00	D-18	
110724-0-01	C-21		110774-0-01	D-17		110815-0-01	F-28		111451-0-00	"	
110725-0-01	C-22~C-26 39.45.47.48.49		110775-0-01	D-16		"	G-22		111486-0-01	B-42	
110726-0-01	C-22		110776-0-01	D-18		110816-0-01	F-26		111496-0-01	F-1	
110727-0-01	Q-39		110777-0-01	"		"	G-20		111505-0-00	D-18	
110728-0-01	C-24		110778-0-01	D-19		110818-0-01	F-36		111605-0-01	D-25	
110729-0-01	C-25		110779-0-01	D-21		110819-0-01	F-37		111606-0-01	D-21	
110730-0-01	C-47		110780-0-01	D-25		110820-0-01	F-32		111607-0-01	D-23	
110731-0-00	C-48		110781-0-01	D-23		"	F-35		112133-0-01	E-21	
110732-0-01	C-49		110782-0-01	D-24		"	G-26		"	G-32	
110733-0-01	C-41		110783-0-01	E-2		110821-0-01	F-39		112136-0-01	E-6	
110734-0-01	C-43		110784-0-01	E-1		110822-0-01	F-34		112192-0-01	E-7	
110735-0-01	C-42		110785-0-01	E-5		110823-0-01	F-22		112348-0-01	A-71	
110736-0-01	C-40		110786-0-01	E-4		110824-0-01	F-19		112467-0-01	A-70	
110737-0-01	C-3		110787-0-01	E-44		110825-0-01	F-20		112778-0-01	C-3	
110738-0-01	D-41.42		110788-0-01	E-45		110827-0-01	F-16		112779-0-01	C-51	
110739-0-00	D-41		110789-0-01	E-46		110828-0-01	F-14		112780-0-01	F-24	
110740-0-01	D-28~D-31		110790-0-01	E-10		110829-0-01	F-12		112830-0-01	F-46	
110741-0-01	D-29		110792-0-01	E-9		110830-0-01	F-10		112834-0-01	F-51	
110742-0-01	D-30		110793-0-01	E-8		110831-0-01	E-55		112835-0-01	F-49	
110743-0-01	D-31		110794-0-01	E-13		110832-0-01	F-31		112836-0-01	F-47	
110744-0-01	D-28		110795-0-01	E-14		"	G-25		112838-0-01	D-25	
110745-0-01	D-32		110796-0-01	E-15		111246-0-01	A-68		112839-0-01	E-30~E-34	
110746-0-00	D-27		110797-0-01	E-19		111248-0-01	A-67		112840-0-01	E-34	
110747-0-01	D-36		110798-0-00	E-17		111267-0-01	A-46		"	E-41	
110748-0-01	D-35		110799-0-01	E-20		"	F-42		112841-0-01	E-33	
110749-0-01	D-39		110800-0-01	E-43		111281-0-01	E-11		113323-0-01	F-40	
110753-0-01	D-40		110801-0-01	E-21~E-29		111282-0-01	A-40		113348-0-00	A-33	
110756-0-01	D-46		110803-0-01	E-22		111283-0-01	A-41		113392-0-01	E-36	
110757-0-01	D-47		"	G-37		111423-0-01	D-18		113428-0-01	G-3	
110758-0-01	D-43		110804-0-01	E-23		111424-0-01	"		113429-0-01	G-5	
110759-0-01	D-49		"	G-38		111425-0-01	"		113430-0-01	G-4	
110760-0-01	D-3		110805-0-01	E-24		111426-0-01	"		113431-0-01	G-6	
110761-0-01	D-4		110806-0-01	G-34		111427-0-01	"		113432-0-01	G-7	
110763-0-00	D-1		110807-0-01	E-26		111428-0-01	"		113433-0-01	G-15	
110764-0-01	D-6		"	E-31		111429-0-01	"		113434-0-01	G-18	
			"	E-38		111430-0-01	"		113435-0-01	G-19	



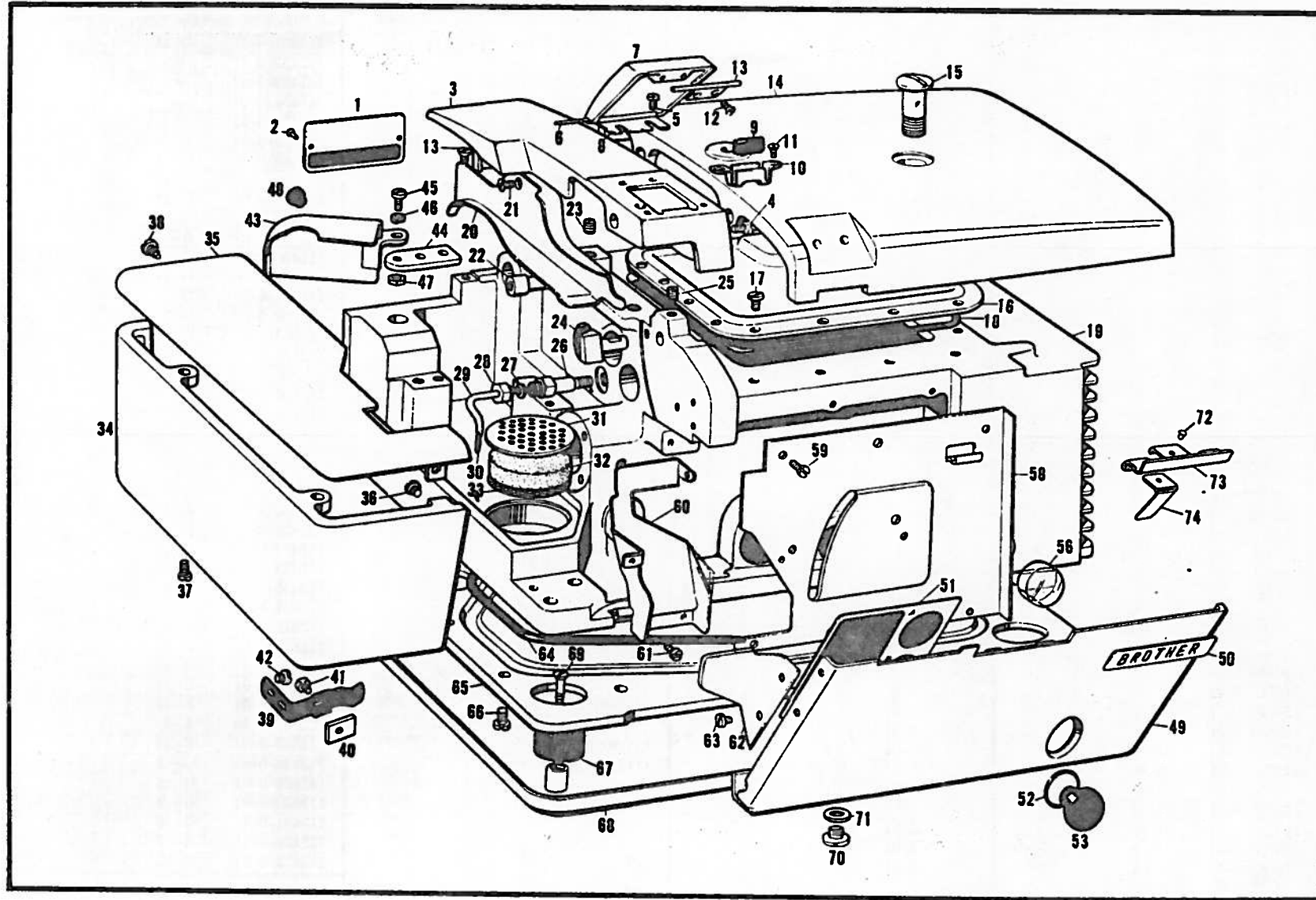

## PARTS LIST FOR FF4-B955

B955-3

Ref.No.	Name of Parts	Q'ty	Parts No.	Assembly No.	Ref.No.	Name of Parts	Q'ty	Parts No.	Assembly No.
A-1	Medallion (EF4-B955-01)	1 pec.	114884-0-01		A-45	Set Screw for A-43	1 pec.	100137-0-03	
	Medallion (EF4-B955-11)	1 ♀	114886-0-01		A-46	Spring Washer for A-45	1 ♀	111267-0-01	110633-0-01
A-2	Medallion Pin	2 pcs.	100010-0-01		A-47	Nut for A-45	1 ♀	106129-0-01	
A-3	Presser Foot Base Cover	1 pec.	114769-0-01		A-48	Cushion for A-34	1 ♀	104450-0-01	
A-4	Set Screw for A-3	2 pcs.	100287-0-03		A-49	Front Cover Assembly	1 ♀	110644-0-01	
A-5	Set Screw for A-8	2 ♀	100242-0-01		A-50	Name Plate "Brother"	1 ♀	140796-0-01	
A-6	Hinge Pin for A-8	1 pec.	114758-0-01		A-51	Threading Diagram (three threads)	1 ♀	114887-0-01	
A-7	Needle Thread Take-up Cover	1 ♀	114757-0-01			Threading Diagram (two threads)	1 ♀	114888-0-01	
A-8	Hinge for A-7	1 ♀	114759-0-01		A-52	Packing for A-53	1 ♀	109203-0-01	
A-9	Magnet	1 ♀	114765-0-00		A-53	Cap Screw	1 ♀	110641-0-01	
A-10	Magnet Case	1 ♀	114764-0-01		A-56	Oil Gauge Indicator	1 ♀	110639-0-01	
A-11	Set Screw for A-10	2 pcs.	102843-0-01		A-58	Inside Cover	1 ♀	110643-0-01	
A-12	Set Screw SM3.75-40×6 for A-13	2 ♀	003670-6-14		A-59	Set Screw for A-58	7 pcs.	100185-0-03	
A-13	Guide Bar for A-7	1 pec.	114760-0-01		A-60	Looper Cover, Large	1 pec.	110654-0-01	
A-14	Top Cover	1 ♀	110616-0-01		A-61	Set Screw for A-60	4 pcs.	100257-0-07	
A-15	Set Screw for A-14	1 ♀	110617-0-01		A-62	Looper Cover, Small	1 pec.	110655-0-01	
A-16	Dust Cover Assembly	1 ♀	110618-0-01		A-63	Set Screw for A-62	2 pcs.	106568-0-01	
A-17	Set Screw for A-16	15 pcs.	100541-0-01		A-64	Bottom Plate Packing	1 pec.	110657-0-01	
A-18	Packing for A-16	1 pec.	110621-0-01		A-65	Bottom Plate	1 ♀	110656-0-01	
A-19	Overlock Machine Body	1 ♀	110614-0-01		A-66	Set Screw for A-65	12 pcs.	107407-0-02	
A-20	Cloth Guide	1 ♀	110627-0-01		A-67	Cushion for A-68	4 ♀	111248-0-01	
A-21	Set Screw for A-20	2 pcs.	102843-0-01		A-68	Oil Pan	1 pec.	111246-0-01	
A-22	Cloth Guide Supporting Stud	1 pec.	110628-0-01		A-69	Set Screw for A-68	4 pcs.	033352-5-02	
A-23	Set Screw for A-22	1 ♀	100013-0-02		A-70	Oil Cap Screw	1 pec.	112467-0-01	
A-24	Upper Knife Driving Arm Guide	1 ♀	110638-0-00		A-71	Packing for A-70	1 ♀	112348-0-01	
A-25	Set Screw for A-24	1 ♀	100013-0-02		A-72	Pin for A-74	1 ♀	041570-2-03	
A-26	Stud for A-28	1 ♀	110629-0-00		A-73	Front Cover Stopper	1 ♀	110649-0-01	
A-27	Oil Tube Packing	1 ♀	110630-0-01		A-74	Front Cover Stopper Spring	1 ♀	110651-0-01	
A-28	Oil Tube Compling Nut	1 ♀	110631-0-00						
A-29	Feed Bar Connecting Rod Oil Tube	1 ♀	110632-0-00						
A-30	Wick 4×4 for A-29	1 ♀	109405-0-01						
A-31	Oil Filter Screen	1 ♀	110636-0-01						
A-32	Oil Filter	1 ♀	110637-0-01						
A-33	Oil Strainer	1 ♀	113348-0-00						
A-34	Cloth Plate Cover	1 ♀	110623-0-01						
A-35	Cloth Plate	1 ♀	110624-0-01						
A-36	Set Screw for A-34	1 ♀	107263-0-01						
A-37	Set Screw for A-34	2 pcs.	100368-0-02						
A-38	Set Screw for A-35	1 pec.	110625-0-01						
A-39	Cloth Plate Latch Spring	1 ♀	110626-0-01						
A-40	Cloth Plate Stopper	1 ♀	111282-0-01						
A-41	Set Screw for A-40	1 ♀	111283-0-01						
A-42	Set Screw for A-39	2 pcs.	102438-0-02						
A-43	Feed Mechanism Cover	1 pec.	110634-0-01	110633-0-01					
A-44	Supporting Plate for A-43	1 ♀	110635-0-01						

B955-4

B

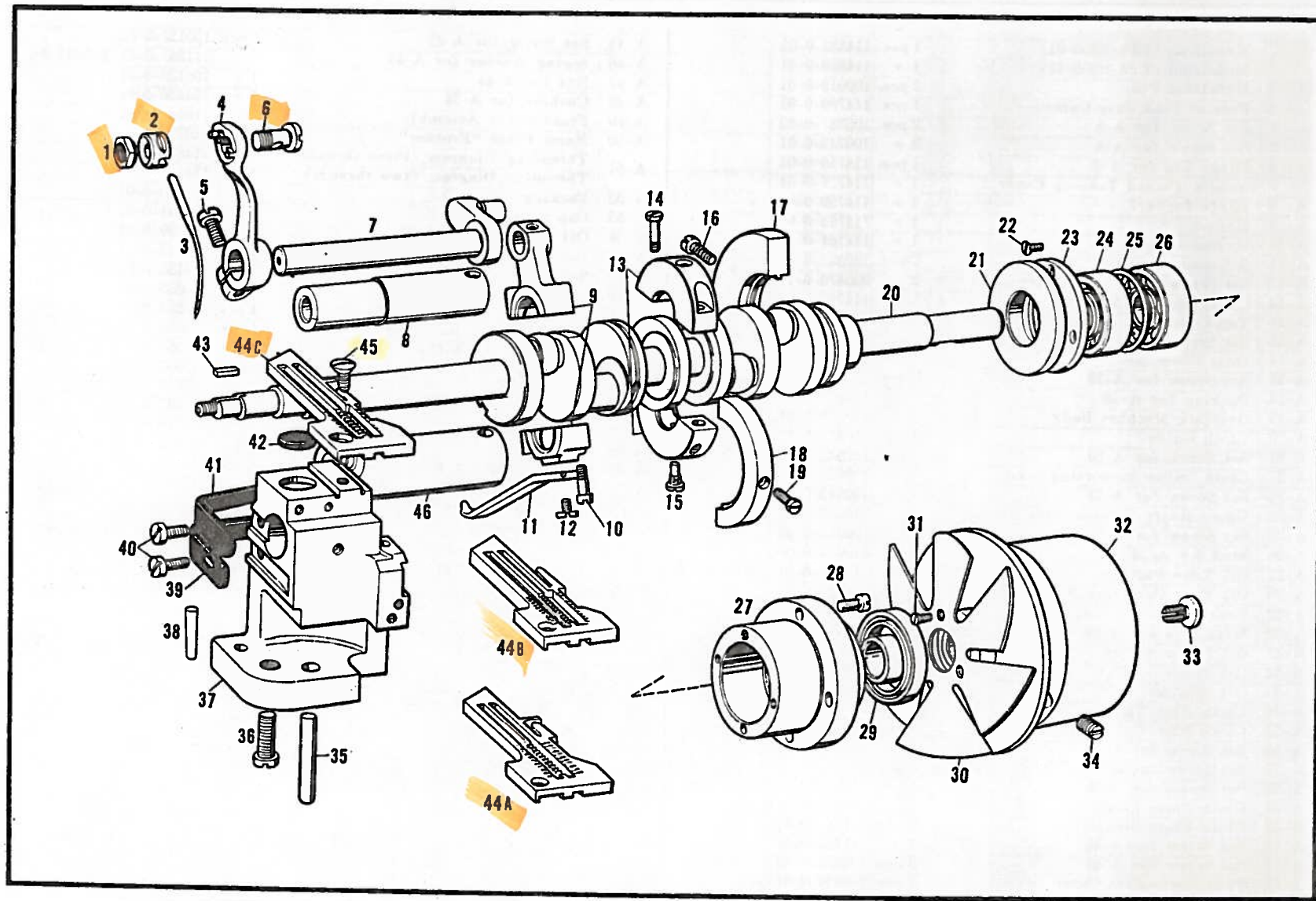

Ref.No.	Name of Parts	Q'ty	Parts No.	Assembly No.	Ref.No.	Name of Parts	Q'ty	Parts No.	Assembly No.
B- 1	Nut for B-2	1 pce.	110693-0-01		B-44	Needle Plate (A) 3mm	1 pce.	114883-0-01	
B- 2	Needle Clamp	1 "	110691-0-01			" (A) 4mm	1 "	114788-0-01	
B- 3	Needle (UO×154)	1 "	110694-0-09			" (A) 5mm	1 "	115841-0-01	
B- 4	Needle Driving Arm	1 "	110690-0-01			" (B) 5mm	1 "	114789-0-01	
B- 5	Set Screw for A-4	1 "	100522-0-01			" (C) 3mm	1 "	114785-0-01	
B- 6	Set Screw for B-2	1 "	110692-0-01			" (C) 4mm	1 "	114786-0-01	
B- 7	Needle Driving Arm Crank	1 "	110688-0-01			" (C) 5mm	1 "	114787-0-01	
B- 8	Needle Driving Arm Crank Bushing	1 "	110689-0-00			" (C) 5mm (Special)	1 "	141182-0-01	
B- 9	Needle Driving Arm Crank Connecting Rod	1 "	110685-0-01	110684-0-01	B-45	Set Screw for B-44	1 "	100032-0-01	
B-10	Set Screw for B-9	2 pcs.	110686-0-01		B-46	Crankshaft Bushing, Left	1 "	110664-0-00	
B-11	Oil Jumping Plate, Left	1 pce.	110687-0-01						
B-12	Set Screw for B-11	1 "	104559-0-02	110665-0-01					
B-13	Crankshaft Inside Bushing	1 "	110666-0-00						
B-14	Set Screw for B-13	2 pcs.	142590-0-01						
B-15	Set Screw for B-13	1 pce.	110668-0-01						
B-16	Set Screw for B-17	1 "	100088-0-02						
B-17	Crankshaft Counterweight, Rrght	1 "	110683-0-00						
B-18	Crankshaft Counterweight, Left	1 "	110682-0-00						
B-19	Set Screw for B-18	1 "	106766-0-01						
B-20	Crankshaft	1 "	110662-0-01						
B-21	Oil Rejector	1 "	110669-0-00						
B-22	Set Screw for B-23	4 dcs.	107244-0-01						
B-23	Ball Bearing Retaining Plate	1 pce.	110673-0-00						
B-24	Ball Bearing	1 "	110671-0-00						
B-25	Washer for B-24, B-26	1 "	110672-0-00						
B-26	Ball Bearing	1 "	110671-0-00						
B-27	Crankshaft Ball Bearing Housing	1 "	110670-0-00						
B-28	Set Screw for B-27	4 pcs.	100368-0-02						
B-29	Crankshaft Ball Bearing Retainer	1 pce.	110674-0-00						
B-30	Pulley fan	1 "	140500-0-01						
B-31	Set Screw for B-30	3 pcs.	102843-0-02						
B-32	Pulley	1 pce.	140499-0-01						
B-33	Cap Screw for B-32	1 "	140180-0-01						
B-34	Set Screw for B-32	2 pcs.	100016-0-03						
B-35	Cloth Plate Cover Stop Stud	1 pce.	110699-0-01						
B-36	Set Screw for B-37	2 pcs.	106764-0-01						
B-37	Needle Plate Support Bracket	1 pce.	110698-0-01						
B-38	Knock Pin for B-37	1 "	107351-0-01						
B-39	Needle Guard, Lower	1 "	110697-0-01						
B-40	Set Screw for B-39 & B-41	2 pcs.	100137-0-02						
B-41	Needle Guard, Upper	1 pce.	110696-0-01						
B-42	Cloth Plate Cushion	1 "	111486-0-01						
B-43	Feed Eccentric Pinion	1 "	110663-0-00						



B955-6

C

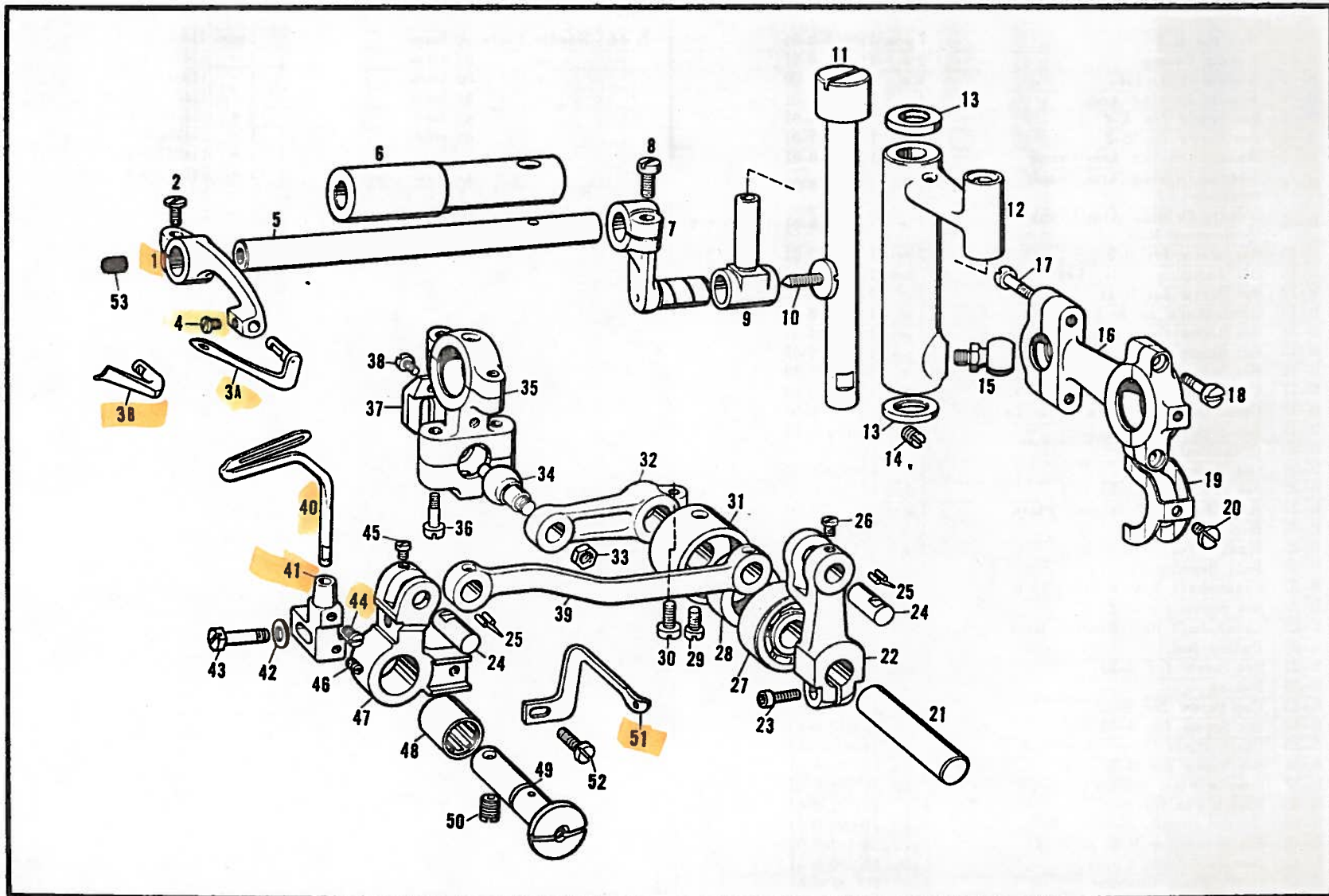

Ref.No.	Name of Parts	Q'ty	Parts No.	Assembly No.	Ref.No.	Name of Parts	Q'ty	Parts No.	Assembly No.
C-1	Over Looper Arm	1 pce.	110715-0-01		C-37	Round Joint Guide	1 pce.	110720-0-01	
C-2	Set Screw for C-1	1 /	100287-0-04		C-38	Set Screw for C-37	1 /	100080-0-03	
C-3	Over Looper A	1 /	110737-0-01		C-40	Under Looper	1 /	110736-0-01	
	Over Looper B (spreader)	1 /	112778-0-01		C-41	Under Looper Holder	1 /	110733-0-01	
C-4	Set Screw for C-3	1 /	111443-0-01		C-42	Washer for C-41	1 /	110735-0-01	
C-5	Over Looper shaft	1 /	110712-0-01		C-43	Set Screw for C-41	1 /	110734-0-01	
C-6	Over Looper Shaft Bushing	1 /	110714-0-01		C-44	Set Screw for C-40	1 /	111443-0-01	
C-7	Over Looper Shaft Connecting	1 /	110709-0-01		C-46	Adjusting Serew for C-41	1 /	104649-0-01	
C-9	Type Joint for C-7	1 /	110710-0-01	110708-0-01	C-50	Set Screw for C-49	1 /	100062-0-04	
C-10	Set Screw for C-7	1 /	110711-0-01		C-51	Looper Small Thread Take-up	1 /	112779-0-01	
C-8	Set Screw for C-7	1 /	100287-0-03		C-52	Set Screw for C-51	1 /	100257-0-08	
C-11	Over Looper Drive Lever Shaft	1 /	110707-0-01		C-53	Cap for C-5	1 /	140421-0-01	
C-12	Over Looper Drive Lever	1 /	110705-0-00						
C-13	Over Looper Shaft Thrust Washer	2 /	110706-0-01						
C-14	Set Screw for C-11	1 /	100013-0-03						
C-15	Over Looper Round Joint	1 /	110703-0-01						
C-16	Over Looper Drive Lever Connecting Rod	1 /	110701-0-01	110700-0-01					
C-17	Set Screw for C-16	2 pcs.	142590-0-01						
C-18	Set Screw for C-16	2 /	142590-0-01						
C-19	Sewing Stopper for C-16	1 pce.	110704-0-01						
C-20	Set Screw for C-19	1 /	105034-0-02						
C-21	Under Looper Bar Connecting Lever Shaft	1 /	110724-0-01						
C-22	Under Looper Drive Lever	1 /	110726-0-01						
C-23	Set Screw M4x12 for C-22	1 /	018401-2-22						
C-24	Rod Pin for Under Looper	2 pcs.	110728-0-01						
C-25	Roller 1.2x5.8	32 /	110729-0-01						
C-26	Set Screw for C-24	1 /	107526-0-01	110725-0-01					
C-39	Under Looper Connecting Bar	1 /	110727-0-01						
C-45	Set Screw for C-24	1 /	107526-0-01						
C-47	Under Looper Arm	1 /	110730-0-01						
C-48	Needle Bearing for C-47	1 /	110731-0-00						
C-49	Under Looper Arm Shaft	1 /	110732-0-01						
C-27	Ball Bearing	1 /	110723-0-00						
C-28	Oil Seal SB8186	1 /	110722-0-01						
C-29	Set Screw for C-31	1 /	105904-0-01						
C-30	Set Screw for C-32	1 /	100368-0-02						
C-31	Under Looper Bushing	1 /	110721-0-01						
C-32	Under Looper Connecting Lever	1 /	110719-0-01						
C-33	Nut for C-34	1 /	105234-0-01						
C-34	Round Joint for C-35	1 /	110718-0-01						
C-35	Under Looper Bar Connecting Rod	1 /	110717-0-01	110716-0-01					
C-36	Set Screw for C-35	4 pcs.	142590-0-01						

B955-8

D

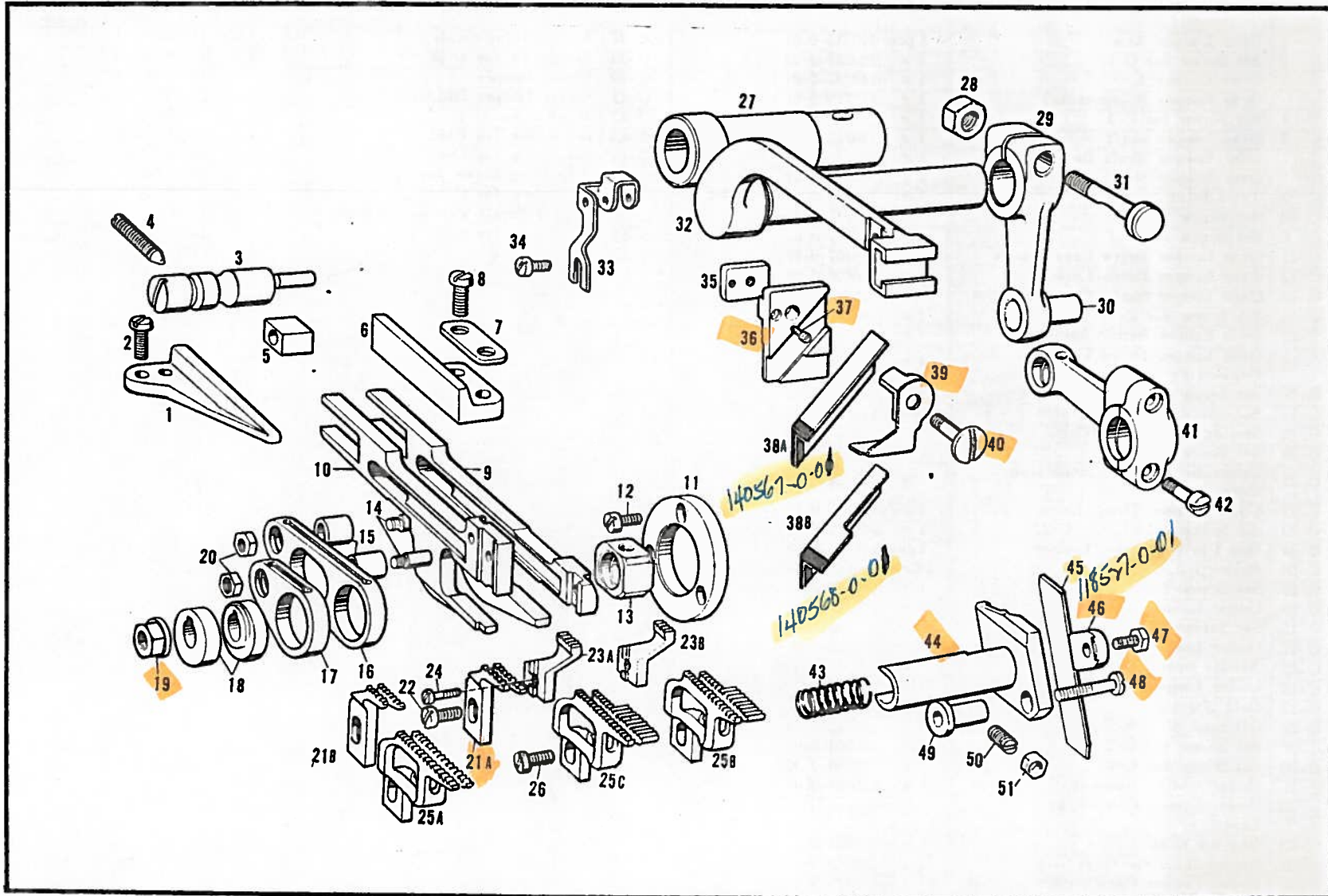

Ref.No.	Name of Parts	Q'ty	Parts No.	Assembly No.	Ref.No.	Name of Parts	Q'ty	Parts No.	Assembly No.
D-1	Main Feed Bar Guide	1 pce.	110763-0-00		D-23	Chaining Feed Dog (B)	1 pce.	111607-0-01	
D-2	Set Screw for D-1	2 pcs.	100086-0-03		D-24	Set Screw for D-23	1 /	110782-0-01	
D-3	Feed Tilting Adjusting Pin	1 /	110760-0-01		D-25	Differential Feed Dog (A)	1 /	112838-0-01	
D-4	Set Screw for D-3	1 /	110761-0-01			" (B)	1 /	111605-0-01	
D-5	Feed Bar Guide Block	1 /	140928-0-00			" (C)	1 /	110780-0-01	
D-6	Differential Feed Bar Guide	1 /	110764-0-01		D-26	Set Screw for D-25	1 /	100368-0-02	
D-7	Washer for D-6	1 /	110765-0-01		D-27	Upper Knife Driving Arm Bushing	1 /	110746-0-00	
D-8	Set Screw for D-6	2 pcs.	100086-0-03		D-28	Nut for D-29	1 /	110744-0-01	
D-9	Differential Feed Bar	1 pce.	110770-0-01	110769-0-01	D-29	Upper Knife Driving Lever	1 /	110741-0-01	110740-0-01
D-10	Main Feed Bar	1 /	110771-0-01		D-30	Pin for D-29	1 /	110742-0-01	
D-14	Feed Bar Driving Stud	2 pcs.	110772-0-01		D-31	Set Screw for C-29	1 /	110743-0-01	
D-11	Differential Feed Bar Thrust Washer	1 pce.	110766-0-01		D-32	Upper Knife Driving Arm	1 /	110745-0-01	
D-12	Set Screw for D-11	4 pcs.	110767-0-01		D-33	Needle Thread Take-up	1 /	114767-0-01	
D-13	Feed Lift Block	1 pce.	110768-0-00		D-34	Set Screw for D-33	1 /	105123-0-01	
D-15	Feed Bar Driving Connections Bushings	2 /	110773-0-01		D-35	Nut for D-36	1 /	110748-0-01	
D-16	Differential Feed Bar Driving Connection	1 pce.	110775-0-01		D-36	Upper Knife Holder Block	1 /	110747-0-01	
D-17	Main Feed Bar Driving Connection	1 /	110774-0-01		D-37	Set Screw for D-36	1 /	106556-0-01	
D-18	Feed Driveng Eccentric 7P		118834-0-01		D-38	Upper Knife (A)	1 /	140567-0-01	
	" 8P		111423-0-01			" (B)	1 /	140568-0-01	
	" 9P		111424-0-01		D-39	Upper Knife Clamp Assembly	1 /	110749-0-01	
	" 10P		111425-0-01		D-40	Set Screw for D-38	1 /	110753-0-01	
	" 11P		111426-0-01		D-41	Upper Knife Driving Connecting Rod	1 /	110739-0-00	110738-0-01
	" 12P		111427-0-01		D-42	Set Screw for D-41	2 pcs.	110686-0-01	
	" 13P		111428-0-01		D-43	Lower Knife Holder spring	1 pce.	110758-0-01	
	" 14P		111429-0-01		D-44	Lower Knife Holder	1 /	114784-0-01	
	" 16P		111430-0-01		D-46	Lower Knife Clamp	1 /	110756-0-01	180156-0-01
	" 18P		110777-0-01		D-47	Set Screw for D-46	1 /	110757-0-01	
	" 20P		110776-0-01		D-45	Lower Knife	1 /	118527-0-01	
	" 23P		111431-0-01		D-48	Set Screw for D-44	1 /	107385-0-01	
	" 26P		111432-0-01		D-49	Lower Knife Holder Guide	1 /	110759-0-01	
	" 29P		111433-0-01		D-50	Set Screw for D-44	1 /	104869-0-02	
	" 32P		111434-0-01		D-51	Nut for D-50	1 /	102571-0-01	
	" 39P		111435-0-01						
	" 42P		111450-0-00						
	" 50P		111451-0-00						
	" 62P		111505-0-00						
D-19	Nut for D-18	1 pce.	110778-0-01						
D-20	Nut for D-16 & D-17	2 pcs.	107556-0-02						
D-21	Main Feed (A)	1 pce.	110779-0-01						
	" (B)	1 /	111606-0-01						
D-22	Set Screw for D-21	1 /	100368-0-02						
D-23	Chaining Feed Dog (A)	1 /	110781-0-01						

B955-10

E

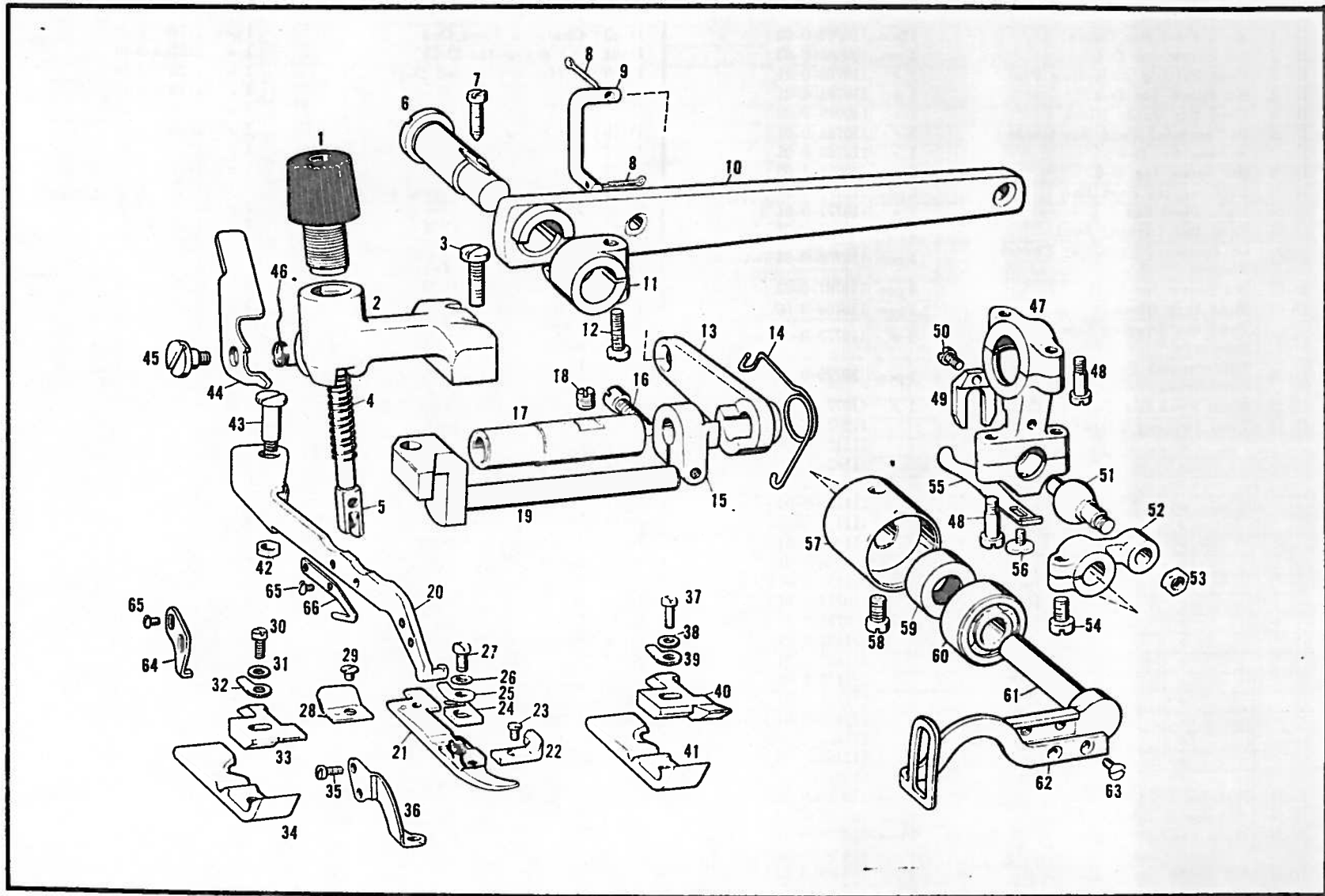

Ref.No.	Name of Parts	Q'ty	Parts No.	Assembly No.	Ref.No.	Name of Parts	Q'ty	Parts No.	Assembly No.
E-1	Presser Arm Adjusting Screw	1 pce.	110784-0-01	114059-0-01	E-40	Presser Foot Stitch Tongue (B)	1 pce.	115740-0-01	115741-0-01
E-2	Presser Foot Base	1 ♀	110783-0-01		E-41	Presser Foot (A)	1 ♀	112840-0-01	
E-4	Presser Spring	1 ♀	110786-0-01		E-42	Nut for E-43	1 ♀	102571-0-01	
E-5	Presser Bar	1 ♀	110785-0-01		E-43	Stud Screw for F-20	1 ♀	110800-0-01	
E-44	Presser Bar Lifter	1 ♀	110787-0-01		E-47	Under Looper Bar Connecting Rod	1 ♀	110717-0-01	
E-45	Stud Screw for E-4	1 ♀	110788-0-01		E-48	Set Screw for E-47	4 pcs.	142590-0-01	110716-0-01
E-46	Spring for E-44	1 ♀	110789-0-01		E-51	Round Joint for E-47	1 pce.	110718-0-01	
E-3	Set Screw for E-2	2 pcs.	106764-0-01		E-49	Round Joint Guide	1 ♀	110720-0-01	
E-6	Presser Foot Lifter Lever Stud	1 pce.	112136-0-01		E-50	Set Screw for E-49	1 ♀	100080-0-03	
E-7	Set Screw for E-6	1 ♀	112192-0-01		E-52	Thread Take-up Stud Lever	1 ♀	110809-0-01	
E-8	Cotter Pin for E-9	2 pcs.	110793-0-01		E-53	Nut for E-51	1 ♀	105234-0-01	
E-9	Presser Foot Lifter Lever Connecting Link	1 pce.	110792-0-01		E-54	Set Screw for E-52	1 ♀	100368-0-03	
E-10	Presser Foot Lifter Lever	1 ♀	110790-0-01		E-55	Oil Jumping Plate	1 ♀	110831-0-01	
E-11	Presser Foot Lifter Controller Body (B)	1 ♀	111281-0-01		E-56	Set Screw for E-55	1 ♀	104559-0-02	
E-12	Set Screw for E-11	1 ♀	107219-0-01	E-57	Under Looper Bushing	1 ♀	110721-0-01		
E-13	Presser Foot Lifter Inside Lever	1 ♀	110794-0-01	E-58	Set Screw for E-57	1 ♀	105904-0-01		
E-14	Presser Foot Lifter Spring	1 ♀	110795-0-01	E-59	Oil Seal SB8186	1 ♀	110722-0-01		
E-15	Presser Foot Lifter Controller Body (A)	1 ♀	110796-0-01	E-60	Ball Bearing	1 ♀	110723-0-00		
E-16	Set Screw for E-15	1 ♀	111436-0-01	E-61	Thread take-up Shaft	1 ♀	110810-0-01		
E-17	Presser Arm Shaft Bushing	1 ♀	110798-0-00	E-62	Looper Thread Take-up	1 ♀	110811-0-01		
E-18	Set Screw for E-17	1 ♀	100013-0-01	E-63	Set Screw for F-62	2 pcs.	108960-0-03		
E-19	Presser Arm Shaft	1 ♀	110797-0-01	E-64	Presser foot Stopper	1 pce.	140504-0-01		
E-20	Presser Arm	1 ♀	110799-0-01	E-65	Set Screw for E-64 & E-66	4 pcs.	400163-0-01		
E-21	Presser Foot (C)	1 ♀	112133-0-01	E-66	Thread Cutting Knife	1 pce.	118856-0-01		
E-22	Presser Foot Chip Guard	1 ♀	110803-0-01						
E-23	Set Screw for E-22	1 ♀	110804-0-01						
E-24	Presser Foot Stitch Tongue (C)	1 ♀	110805-0-01						
E-25	Presser Foot Hinge Spring	1 ♀	110806-0-01	110801-0-01					
E-26	Washer for E-27	1 ♀	110807-0-01						
E-27	Set Screw for E-25	1 ♀	100080-0-02						
E-28	Presser Foot Chain Shield	1 ♀	110808-0-01						
E-29	Set Screw for E-28	1 ♀	100105-0-02						
E-30	Set Screw for E-32	1 ♀	100080-0-02						
E-31	Washer for E-30	1 ♀	110807-0-01						
E-32	Presser Foot Hinge Spring	1 ♀	114727-0-01	112839-0-01					
E-33	Presser Foot Stitch Tongue (A)	1 ♀	112841-0-01						
E-34	Presser Foot (A)	1 ♀	112840-0-01						
E-35	Set Screw for E-36	2 pcs.	120048-0-02						
E-36	Presser Foot Fixed Plate	1 pce.	113392-0-01						
E-37	Set Screw for E-39	1 ♀	100080-0-02						
E-38	Washer for E-37	1 ♀	110807-0-01	115741-0-01					
E-39	Presser Foot Hinge Spring	1 ♀	114727-0-01						

B955-12

F

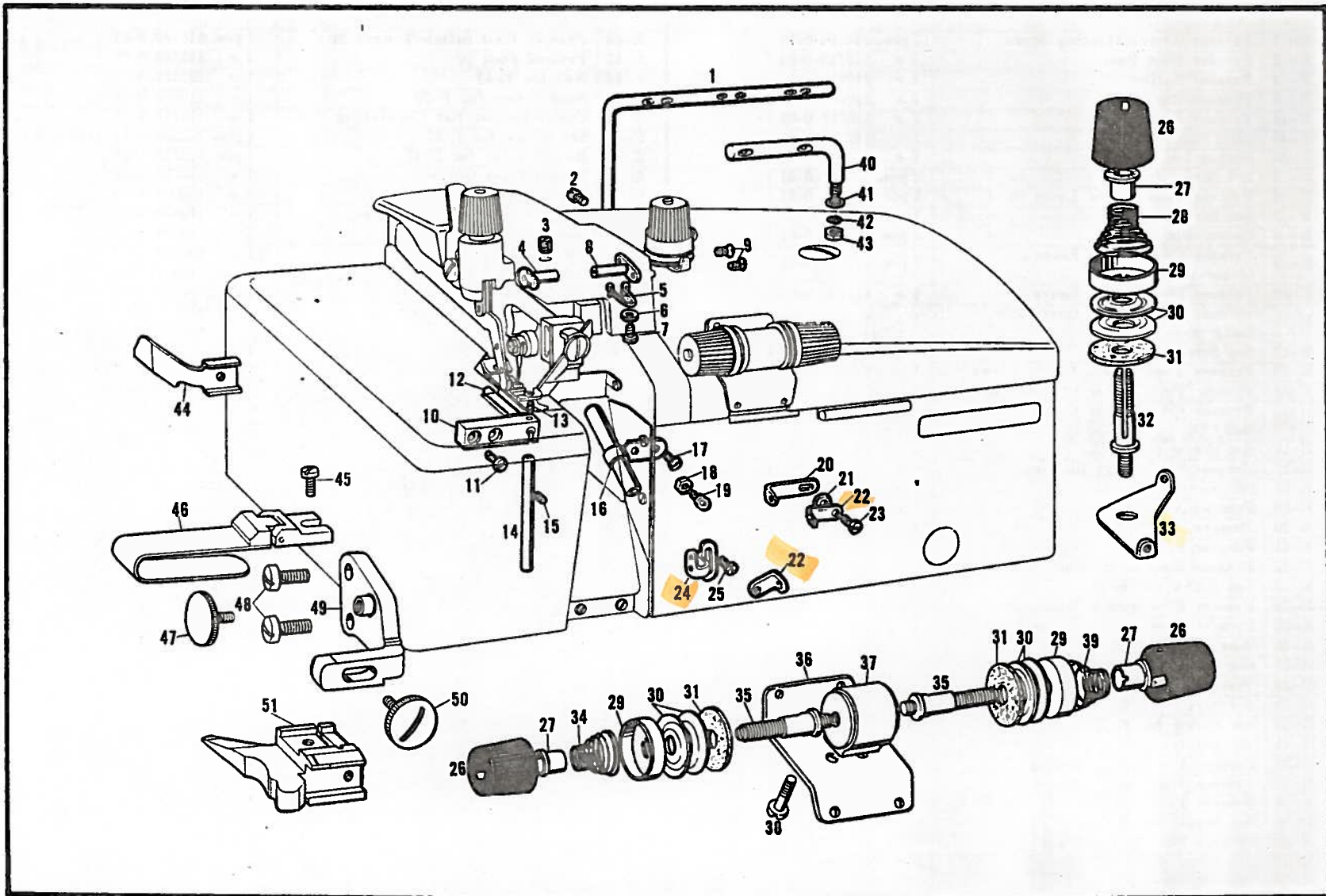

Ref.No.	Name of Parts	Q'ty	Parts No.	Assembly No.	Ref.No.	Name of Parts	Q'ty	Parts No.	Assembly No.
F-1	Thread Guide	1 pce.	111496-0-01		F-42	Spring Washer for F-40	1 pce.	111267-0-01	
F-2	Set Scerw for F-1	2 pcs.	100541-0-03		F-43	Nut for F-40	1 /	106129-0-01	
F-3	Ses Screw for F-4	1 pce.	107086-0-01		F-44	Cloth Guide Ruler	1 /	115742-0-01	
F-4	Needle Thread Guide Pipe (B)	1 /	114761-0-01		F-45	Set Screw for F-46	1 /	105123-0-01	
F-5	Needle Thread Take up Thread Guide	1 /	114766-0-01		F-46	Edge Hemming Ruler Assembly	1 /	112830-0-01	
F-6	Washer for F-5	1 /	102707-0-01		F-47	Adjusting Screw for Ruler	1 /	112836-0-01	
F-7	Set Screw for F-5	1 /	100257-0-08		F-48	Set Screw for F-49	2 pcs.	100086-0-03	
F-8	Needle Thread Guide Pipe (A)	1 /	114772-0-01		F-49	Edge Hemmer Ruler Fitting Holder	1 pce.	112835-0-01	
F-9	Set Screw for F-8	2 pcs.	102843-0-01		F-50	Adjusting Screw for F-49	1 /	114855-0-01	
F-10	Under Looper Thread Guide Base	1 pce.	110830-0-01		F-51	Edge Hemming Ruler (B)	1 /	112834-0-01	
F-11	Set Screw for F-10	2 pcs.	100137-0-04						
F-12	Under Looper Thread Guide Tube(B)	1 pce.	110829-0-01						
F-13	Set Screw for F-12	1 /	104651-0-01						
F-14	Under Looper Thread Guide Tube(A)	1 /	110828-0-01						
F-15	Set Screw for F-14	1 /	100402-0-03						
F-16	Over Looper Thread Guide Tube	1 /	110827-0-01						
F-17	Set Screw for F-16	2 pcs.	100242-0-04						
F-18	Nut SM3.18-40 for F-19	1 pce.	021660-0-03						
F-19	Under Looper Thread Guide, Left	1 /	110824-0-01						
F-20	Under Looper Thread Guide, Right	1 /	110825-0-01						
F-21	Washer for F-22	1 /	110807-0-01						
F-22	Looper Thread Guide	2 pcs.	110823-0-01						
F-23	Serew for F-22	1 pce.	100080-0-02						
F-24	Thread Guide for small Take-up	1 /	112780-0-01						
F-25	Set Screw for F-24	1 /	100080-0-02						
F-26	Thread Tension Adjusting Screw	3 pcs.	110816-0-01						
F-27	Under Thread Tension Spring Washer	3 /	105228-0-01						
F-28	Needle Thread Tension Spring	1 pce.	110815-0-01						
F-29	Tension Disc Washer	3 pcs.	109814-0-01						
F-30	Tension Disc	6 pcs.	108721-0-01						
F-31	Felt for F-30	3 pcs.	110832-0-01						
F-32	Needle Thread Tension Control Stud	1 pce.	110820-0-01						
F-33	Needle Thread Guide	1 /	110813-0-01						
F-34	Under Looper Thread Tension Spring	1 /	110822-0-01						
F-35	Looper Thread Tension Control Stud	2 pcs.	110820-0-01						
F-36	Looper Thread Tension Bracket Thread Guide	1 pce.	110818-0-01						
F-37	Looper Thread Tension Bracket	1 /	110819-0-01						
F-38	Set Screw for F-37	2 pcs.	105205-0-01						
F-39	Over Looper Thread Tension Spring	1 pce.	110821-0-01						
F-40	Thread Guide, Small	1 /	113323-0-01						
F-41	Washer for F-40	1 /	105248-0-01						



This chart shows the different parts from Brother Model EF4-B955. Other parts are same as EF4-B955.

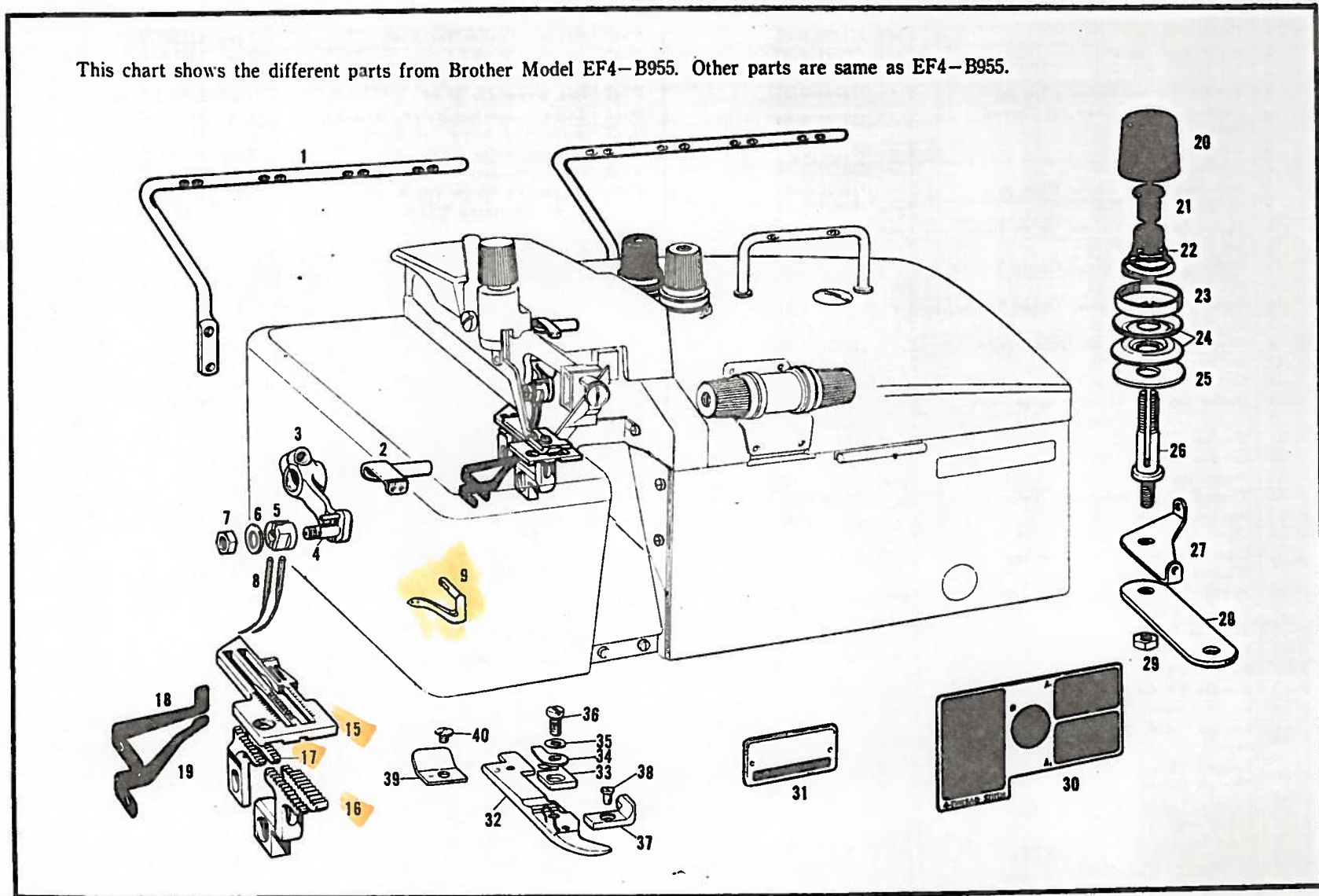

G

PARTSLIST FOR EF4-B953

B955-15

Ref.No.	Name of Parts	Q'ty	Parts No.	Assembly No.	Ref.No.	Name of Parts	Q'ty	Parts No.	Assembly No.
This Chart shows the different parts from Brother Model EF4-B955. Other parts are same as EF4-B955.									
G-1	Thread Guide	1 pce.	113441-0-01						
G-2	Needle Thread Guide Pipe	1 //	114762-0-01						
G-3	Needle Driving Arm	1 //	113428-0-01						
G-4	Set Screw for Needle Clamp	1 //	113430-0-01						
G-5	Needle Clamp	1 //	113429-0-01						
G-6	Washer for G-5	1 //	113431-0-01						
G-7	Nut for G-5	1 //	113432-0-01						
G-8	Needle (Uox154)	2 pcs.	110694-0-09						
G-9	Over Looper	1 pce.	113926-0-01						
G-15	Needle Plate	1 //	113433-0-01						
G-16	Differential Feed Dog (36p)	1 //	113436-0-01						
G-17	Main Feed Dog (36p)	1 //	113437-0-01						
G-18	Needle Guard. Upper	1 //	113434-0-01						
G-19	Needle Guard. Lower	1 //	113435-0-01						
G-20	Thread Tension Adjusting Screw	2 pcs.	110816-0-01						
G-21	Thread Tension Spring Washer	2 //	105228-0-01						
G-22	Needle Thread Tension Spring	2 //	110815-0-01						
G-23	Tension Disc Washer	2 //	109814-0-01						
G-24	Tension Disc	4 pcs.	108721-0-01						
G-25	Felt for G-24	2 pcs.	110832-0-01						
G-26	Needle Thread Tension Control Stud	1 pce.	110820-0-01						
G-27	Needle Thread Guide	2 pcs.	110813-0-01						
G-28	Plate for Needle Thread Tension Control Stud	1 pce.	113439-0-01						
G-29	Nut for G-26	1 //	102571-0-01						
G-30	Threading Diagram	1 //	114911-0-01						
G-31	Medallion	1 //	114479-0-01						
G-32	Presser foot	1 //	112133-0-01						
G-33	Presser foot Stitch Tongue	1 //	117037-0-01						
G-34	Presser foot hinge Spring	1 //	110806-0-01						
G-35	Washer for G-36	1 //	110807-0-01						
G-36	Set Screw for G-34	1 //	100080-0-02	117036-0-01					
G-37	Presser foot Chip Guard	1 //	110803-0-01						
G-38	Set Screw for G-37	1 //	110804-0-01						
G-39	Presser foot Chain Shield	1 //	110808-0-01						
G-40	Set Screw for G-39	1 //	100105-0-01						