

FD4-B276

FD4-B277

パーツブック

PARTS BOOK

TEILEKATAROG

LIVRE DES PIECES

LIBRO DE REFERENCIA DE PIEZAS

平型片面飾り縫自動糸切りミシン

平型両面飾り縫自動糸切りミシン

FLAT-BED BOTTOM-COVERING STITCHER WITH THREAD TRIMMER

FLAT-BED TOP-AND BOTTOM-COVERING STITCHER WITH THREAD TRIMMER

UNTERDECKSTICHMASCHINE MIT FLACHBETT UND FADENABSCHNEIDER

OBER-UND UNTERDECKSTICHMASCHINE MIT FLACHBETT UND
FADENABSCHNEIDER

MACHINE A POINT DE RECOUVREMENT INFERIEUR A PLATEAU AVEC
COUPE-FILS

MACHINE A POINT DE RECOUVREMENT SUPERIEUR ET INFERIEUR A
PLATEAU AVEC COUPE-FILS

MAQUINA DE COSER PUNTO DE REVESTIMIENTO INFERIOR, DE CAMA PLANA,
CON CORTAHILOS

MAQUINA DE COSER PUNTO DE REVESTIMIENTO INFERRIOR Y SUPERIOR, DE
CAMA PLANA, CON CORTAHILOS

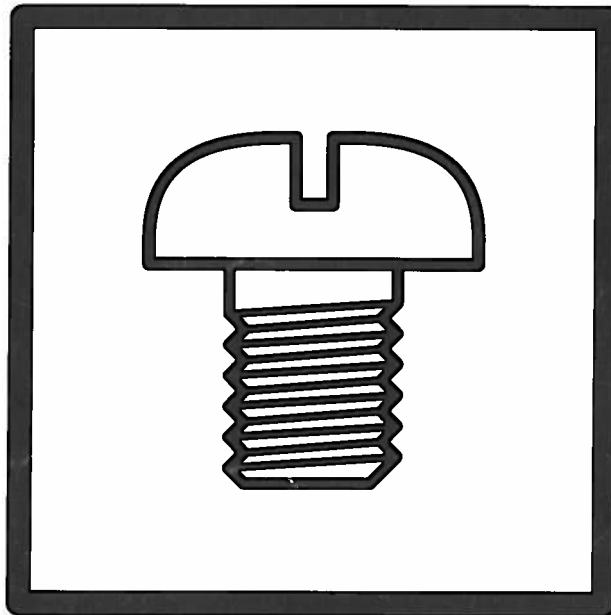

P276101

brother®

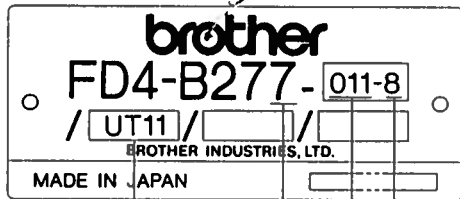

A	機種記号 Model
6	片面飾り Bottom covering stitcher
7	両面飾り Top and bottom covering stitcher

B	C	仕様 Specifications
01	1	地縫用 Plain stitching
03	3	カバーリング用 Covering
05	1	ヘム縫用 Hem stitching

D	針数・針幅 No. of needles · needle gauge
1	二本針・3.2mm 2 needles
2	〃 〃 ・4.0mm
3	〃 〃 ・4.8mm
4	〃 〃 ・5.6mm
5	〃 〃 ・6.4mm
6	三本針・4.8mm 3 needles
7	〃 〃 ・5.6mm
8	〃 〃 ・6.4mm

E	付属装置 / Device					
	電磁式糸切り Solenoid type thread trimmer	エア式糸切り Air type thread trimmer	電磁式ワイパー Solenoid type thread wiper	電磁式 上飾り糸切り Solenoid type spreader thread trimmer	電磁式押え上げ Solenoid type presser foot lifting	エア式 押え上げ Air type presser foot lifting
UT11	○	—	—	—	—	—
UT12 (B276)	○	—	○	—	—	—
UT13	○	—	—	—	○	—
UT14 (B276)	○	—	○	—	○	—
UT32 (B277)	○	—	—	○	—	—
UT34 (B277)	○	—	—	○	○	—
UT21	—	○	—	—	—	—
UT22 (B276)	—	○	○	—	—	—
UT23	—	○	—	—	—	○
UT24 (B276)	—	○	○	—	—	○
UT42 (B277)	—	○	—	○	—	—
UT44 (B277)	—	○	—	○	—	○

パーツブックご利用に際して

1. この本は、この本の表紙(正誤表の挿入されている場合は正誤表)に記載されているものと同じプレートが取り付けられているミシンのためのものです。
2. 標準以外で使用する部品は

011 033

 で示します。尚、実線内の数字はサブクラスを表しています。
3. この本は、1994年2月のデータに基づいて作成されたものです。
4. 部品は予告なしに設計変更される場合があります。
5. 組単位で補給する部品は、[] 破線で示しております。
6. 部品コード欄が※となっている場合は、ゲージ部品一覧表(53ページ)でお調べください。

目 次

A1. 主体関係	1
A2. 主体関係	5
B. 針冷却関係	5
C. 上軸・針棒関係	7
D. 押エ関係	9
E. 送り関係	11
F. 下軸関係	15
G. ルーパー関係	17
H. 給油潤滑関係	19
J. スプレダー関係(B277)	21
K1. 糸調子関係(B276)	23
K2. 糸調子関係(B277)	27
L. 糸払い関係(B276)	31
M. 針位置検出器関係	31
N1. 下飾り糸切り関係	33
N2. 下飾り糸切り関係	37
P. 上飾り糸切り関係(B277)	41
Q. 電磁押エ上ゲ関係	43
R. エアー押エ上ゲ関係	45
Z. 付属品関係	47
ゲージ部品一覧表	53~56
索引	57~62

Notes for using this parts book

1. This book is applicable to sewing machines which have the same plate number as shown on the cover of this book (or correction sheet).
2. Non-standard parts are indicated with

011 033

 Numbers inside the line indicate the subclass.
3. This book was prepared based on information available in February 1994.
4. Parts are subject to changes in design without prior notice.
5. Parts supplied as complete assemblies are circled by a dotted line [-----] .
6. Check the gauge parts list (page 53) if there is an asterisk ※ in the parts code column.

CONTENTS

A1. Machine body	1
A2. Machine body	5
B. Needle cooler	5
C. Upper shaft and needle bar mechanism	7
D. Presser foot mechanism	9
E. Feed mechanism	11
F. Lower shaft mechanism	15
G. Looper mechanism	17
H. Lubrication	19
J. Spreader mechanism(B277)	21
K1. Thread tension(B276)	23
K2. Thread tension(B277)	27
L. Thread wiper mechanism(B276)	31
M. Synchronizer	31
N1. Lower thread trimmer mechanism	33
N2. Lower thread trimmer mechanism	37
P. Upper thread trimmer mechanism(B277)	41
Q. Presser foot lifting solenoid mechanism	43
R. Pneumatic presser foot lifting mechanism	45
Z. Accessories	47
GAUGE PARTS LIST	53~56
INDEX	57~62

Hinweise zur Verwendung dieser Teilleiste

1. Dieses Buch bezieht sich auf die Nähmaschinen mit derselben Kennungsnummer wie auf diesem Buchumschlag (oder auf dem Korrekturblatt).
2. Nicht-Standardteile werden mit

011 033

 bezeichnet. Mit den Zahlen innerhalb der Linie wird die Unterklasse angegeben.
3. Dieses Buch basiert auf den Informationen vom Februar 1994.
4. Modelländerungen sind vorbehalten.
5. Die Teile, die als kompletter Satz geliefert werden, sind mit einer

--

 gestrichelten Linie umrandet.
6. Falls in der Kolonne Teilecode ein Asteriskus ※ vorhanden ist, muß die Teilleiste (Seite 53) kontrolliert werden.

INHALTSVERZEICHNIS

A1. Maschinengehäuse	1
A2. Maschinengehäuse	5
B. Nadelkühlungsvorrichtung	5
C. Obere Welle und Nadelstangenvorrichtung	7
D. Stoffdrückerfuß	9
E. Transportvorrichtung	11
F. Untere Welle	15
G. Greifer	17
H. Schmierung	19
J. Spreizvorrichtung(B277)	21
K1. Faderspannung(B276)	23
K2. Faderspannung(B277)	27
L. Fadenwischvorrichtung(B276)	31
M. Synchronisator	31
N1. Unterefadenabschneider	33
N2. Unterefadenabschneider	37
P. Oberfadenabschneider(B277)	41
Q. Solenoidsatz für die anhebung des stoffdrückerfußes	43
R. Pneumatische stoffdrückerfußanhebevorrichtung .	45
Z. Zubehör	47
LEHRENLISTE	53~56
VERZEICHNIS	57~62

Notes sur l'utilisation de ce manuel de pièces détachées

1. Ce manuel est destiné aux machines à coudre ayant le même numéro de plaque montré sur la couverture de ce manuel (ou sur la feuille de corrections).
2. Les pièces non-standard sont indiquées para un

011 033

. Les numéros de la ligne indiquent la sous-classification.
3. Ce manuel a été fait d'après les renseignements valables au mois de Février 1994.
4. Les pièces peuvent être sujettes à des modifications sans préavis.
5. Les pièces fournies en tant qu'assemblages complets sont encadrées avec un trait pointillé [] .
6. Vérifier la liste des pièces d'écartement (page 53) pour voir s'il y a un astérisque ※ dans la colonne des codes de pièces.

TABLE DES MATIERES

A1. Corps de la machine	1
A2. Corps de la machine	5
B. Mécanisme du refroidisseur d'aiguille	5
C. Mécanisme de arbre supérieur et barra à aiguille ..	7
D. Mécanisme de pied presseur	9
E. Mécanisme de l'entraînement	11
F. Mécanisme de l'arbre inférieur	15
G. Mécanisme des griffes	17
H. Lubrification	19
J. Mécanisme de l'etendeur(B277)	21
K1. Tension du fil(B276)	23
K2. Tension du fil(B277)	27
L. Mécanisme de tire-fil(B276)	31
M. Synchronisateur	31
N1. Mécanisme de coupe-fils inférieur	33
N2. Mécanisme de coupe-fils inférieur	37
P. Mécanisme de coupe-fils supérieur(B277)	41
Q. Conjunto aéreo del levantador del pie	43
R. Dispositif pneumatique de releveur de pied presseur	45
Z1. Accessoires	47
LISTE DES PIECES D'ECARTEMENT	53~56
INDEX	57~62

Notas para usar este Manual de Piezas

1. Este libro sirve para todas las máquinas de coser que llevan la misma placa de identificación que la que se puede ver en la tapa de este libro (o en la hoja de erratas).
2. Las piezas no estándar se indican con

011
033

. Los números en la línea indican la subclase.
2. Este libro ha sido compilado basándose en los datos de que se disponía en febrero 1994.
3. Las piezas quedan sujetas a cambios de diseño sin aviso previo.
4. Las piezas suministradas como conjuntos completos se enmarcan con una línea punteada [-----] .
5. Consultar la lista de piezas calibradoras (página 53) si hay un asteriscos ※ en la columna de código de piezas.

INDICE

A1. Cuerpo de la máquina	1
A2. Cuerpo de la máquina	5
B. Mecanismo del enfriador de aguja	5
C. Mecanismo del eje superior y la barra de aguja ...	7
D. Mecanismo de la prensa tela	9
E. Mecanismo de la alimentación	11
F. Mecanismo del eje inferior	15
G. Mecanismo del presilladora	17
H. Lubricación	19
J. Mecanismo extendedor(B277)	21
K1. Tensión del hilo(B276)	23
K2. Tensión del hilo(B277)	27
L. Mecanismo del limpiador de hilo(B276)	31
M. Sincronizador	31
N1. Dispositivo de cortahilos inferior	33
N2. Dispositivo de cortahilos inferior	37
P. Dispositivo de cortahilos superior(B277)	41
Q. Conjunto solenoide del levantador	43
R. Levantador neumático del prensatelas	45
Z1. Accesorios	47
LISTA DE PIEZAS DE CALIBRADORES	53~56
INDICE	57~62

A1. 主体関係 / Machine body / Maschinengehäuse /
 Corps de la machine / Cuerpo de la máquina

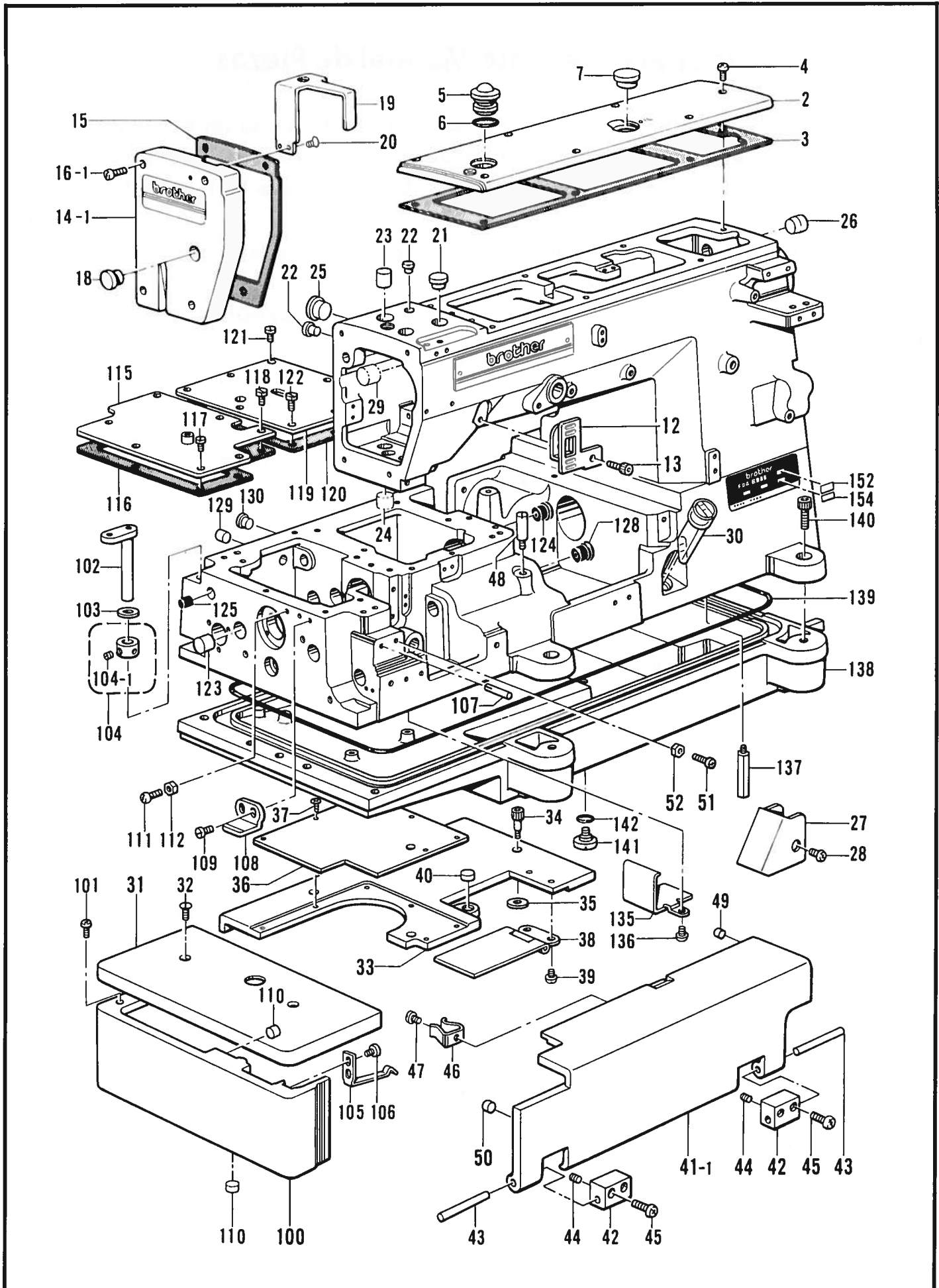

118-276.277-052

A1. 主体関係 / Machine body / Maschinengehäuse /
Corps de la machine / Cuerpo de la máquina

REF.NO.	CODE	Q'TY	ヒンメイ	NAME OF PARTS	RM
2	S08627001	1	ウフフタ	TOP COVER	
3	S08628000	1	ウフフタパツキン	TOP COVER PACKING	
4	062681012	7	ナベコ437-40X10	SCREW, PAN M4.37-40X10	
5	S02606000	1	ユリヨウケイマド	OIL GAUGE WINDOW	
6	081014670	1	OリングPW14	O RING,PW14	
7	159150009	1	カマジクメクラセン	OIL CAP	
12	S08629009	1	ハリイトクリカパー	NEEDLE THREAD TAKE-UP COVER	
13	018060822	1	アナボルト6X8	BOLT, SOCKET M6X8	
14-1	S08630201	1	メンイタ	FACE PLATE	
15	S08631000	1	メンイタパツキン	FACE PLATE PACKING	
16-1	062681612	4	ナベコ437-40X16	SCREW, PAN M4.37-40X16	
18	117934009	1	メクラセン	OIL CAP	
19	S08632009	1	ハリボウテンピンカバー	NEEDLE BAR TAKE-UP COVER	
20	102843004	2	サラネジ3.57	SCREW, FLAT M3.57	
21	104449009	1	メクラセン	OIL CAP	
22	104450109	2	メクラセン	OIL CAP	
23	154841009	1	メクラセン	OIL CAP	
25	108520009	1	メクラセン	OIL CAP	
26	S00313009	1	メクラセン	OIL CAP	
27	S08633101	1	シタイトカバー	BOBBIN THREAD COVER	
28	062680812	1	ナベコ437-40X8	SCREW, PAN M4.37-40X8	
30	148084001	1	オイルゲージマド	OIL GAUGE WINDOW	
31	S21813001	1	クロスプレートL	CLOTH PLATE (L)	
32	100032004	2	サラネジ4.37	SCREW, FLAT M4.37	
33	S21814001	1	クロスプレートR	CLOTH PLATE (R)	
34	S09123101	3	アナボルト4.37X15	BOLT, SOCKET M4.37X15	
35	S08639000	1	クロスプレートパツキン	CLOTH PLATE PACKING	
36	S21815001	1	スベリイタ	SLIDER PLATE	
37	102843004	6	サラネジ3.57	SCREW, FLAT M3.57	
38	S08642001	1	シタイトテンピンカバークミ	LOOPER THREAD TAKE-UP COVER ASSY	
39	123185001	2	マルヒラネジ3.57X4.5	SCREW, OVAL M3.57X4.5	
40	S08646100	1	マグネット	MAGNET	
41-1	S21816001	1	マエカバー	FRONT COVER	
42	S08651001	2	マエカバーササエ	FRONT COVER SUPPORT	
43	S08652000	2	マエカバーササエジク	FRONT COVER SUPPORT SHAFT	
44	153675001	2	アナトメネジ4.37	SET SCREW, SOCKET M4.37	
45	060681612	4	バインド437-40X16	SCREW, BIND M4.37-40X16	
46	114985001	1	ベツトカバートメバネ	SPRING, PLATE	
47	062680612	1	ナベコ4.37-40X6	SCREW, PAN M4.37-40X6	
48	S08653001	1	バネウケネジ	SCREW	
49	142274009	2	メクラセン	OIL CAP	
50	146586009	1	メクラセン	OIL CAP	
51	062681412	1	ナベコ437-40X14	SCREW, PAN M4.37-40X14	
52	105234003	1	ナツト4.37	NUT, M4.37	
100	S08665001	1	ヨコカバー	SIDE COVER	
101	062680812	2	ナベコ437-40X8	SCREW, PAN M4.37-40X8	
102	S00017001	1	クロスプレートササエジク	CLOTH PLATE SUPPORT SHAFT	
103	141183000	1	クロスプレートシート	CLOTH PLATE SEAT	
104	181969003	1	セツトカラークミ	SET COLLAR ASSY	
104-1	101706001	2	トメネジ6.35	SET SCREW, M6.35	
105	S08667001	1	ヨコカバートメイタバネ	SPRING, PLATE	
106	060680712	2	バインド437-40X7	SCREW, BIND M4.37-40X7	
107	140063001	1	ミゾツキピン	DOWEL PIN	
108	S08668001	1	ヨコカバーガイド	SIDE COVER GUIDE	
109	107407003	2	シメネジ4.37	SCREW, M4.37	
110	146586009	2	メクラセン	OIL CAP	
111	062681012	1	ナベコ437-40X10	SCREW, PAN M4.37-40X10	
112	105234003	1	ナツト4.37	NUT, M4.37	
115	S08669001	1	オクリキコウカバー	FEED MECHANISM COVER	

A1. 主体関係 / Machine body / Maschinengehäuse /
 Corps de la machine / Cuerpo de la máquina

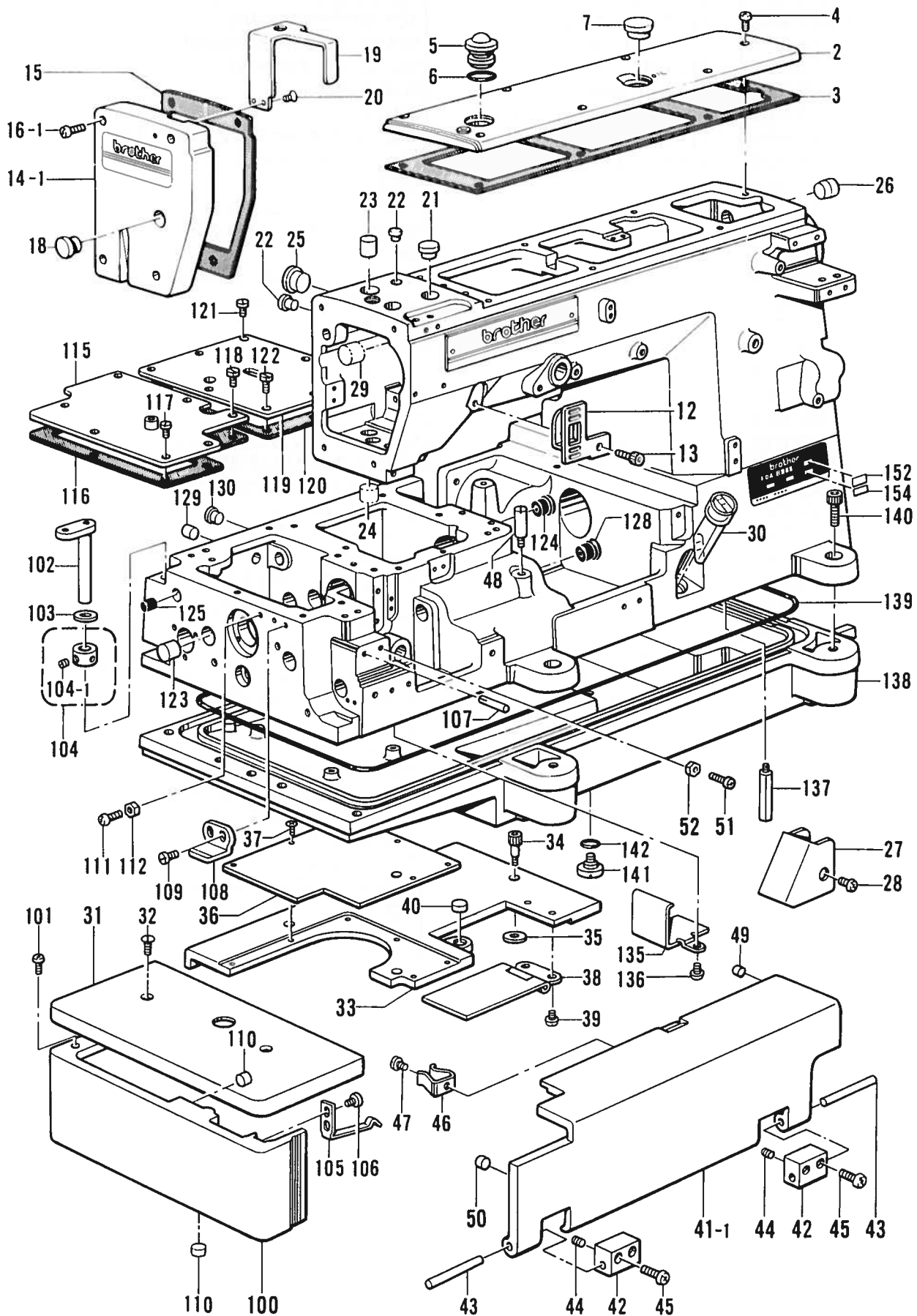

118-276,277-052

A1. 主体関係 / Machine body / Maschinengehäuse /
Corps de la machine / Cuerpo de la máquina

REF.NO.	CODE	Q'TY	ヒンメイ	NAME OF PARTS	RM
116	S08670000	1	オクリキコウカバーハツキン	FEED MECHANISM COVER PACKING	
117	107407003	6	シメネジ4.37	SCREW, M4.37	
118	117516001	1	ボルト4.37	BOLT, M4.37	
119	S21959001	1	ベッドウワカバー	BED UPPER COVER	
120	S08672000	1	ベッドウワカバーハツキン	BED UPPER COVER PACKING	
121	107407003	4	シメネジ4.37	SCREW, M4.37	
122	117516001	2	ボルト4.37	BOLT, M4.37	
123	S00313009	1	メクラセン	OIL CAP	
124	S08673000	1	メクラセン	OIL CAP	
125	146315000	1	メクラセン	OIL CAP	
128	S08673000	1	メクラセン	OIL CAP	
129	146586009	1	メクラセン	OIL CAP	
130	104450109	1	メクラセン	OIL CAP	
135	146457001	1	シクリイタ	OIL STOPPER PLATE	
136	062670612	2	ナベコ357-40X6	SCREW, PAN M3.57-40X6	
137	151059001	4	ホンタイシチュウ	MACHINE BODY LEG	
138	S08674000	1	アブラウケ	OIL RESERVOIR	
139	S08675000	1	Oリング	O RING	
140	018081622	5	アナボルト8X16	BOLT, SOCKET M8X16	
141	110641002	1	ダンネジ9.52	STUD SCREW, M9.52	
142	109203001	1	Oリング	O RING	
152	※	1	シヨウラベル	LABEL	
<B276,B277>					
154	S10696027	1	ソウチヒヨウジラベル (UT11)	DEVICE LABEL (UT11)	
154	S10696029	1	ソウチヒヨウジラベル (UT13)	DEVICE LABEL (UT13)	
154	S10696033	1	ソウチヒヨウジラベル (UT21)	DEVICE LABEL (UT21)	
154	S10696035	1	ソウチヒヨウジラベル (UT23)	DEVICE LABEL (UT23)	
<B276>					
154	S10696028	1	ソウチヒヨウジラベル (UT12)	DEVICE LABEL (UT12)	
154	S10696030	1	ソウチヒヨウジラベル (UT14)	DEVICE LABEL (UT14)	
154	S10696034	1	ソウチヒヨウジラベル (UT22)	DEVICE LABEL (UT22)	
154	S10696036	1	ソウチヒヨウジラベル (UT24)	DEVICE LABEL (UT24)	
<B277>					
154	S10696031	1	ソウチヒヨウジラベル (UT32)	DEVICE LABEL (UT32)	
154	S10696032	1	ソウチヒヨウジラベル (UT34)	DEVICE LABEL (UT34)	
154	S10696037	1	ソウチヒヨウジラベル (UT42)	DEVICE LABEL (UT42)	
154	S10696038	1	ソウチヒヨウジラベル (UT44)	DEVICE LABEL (UT44)	

A2. 主体関係 / Machine body / Maschinengehäuse /
Corps de la machine / Cuerpo de la máquina

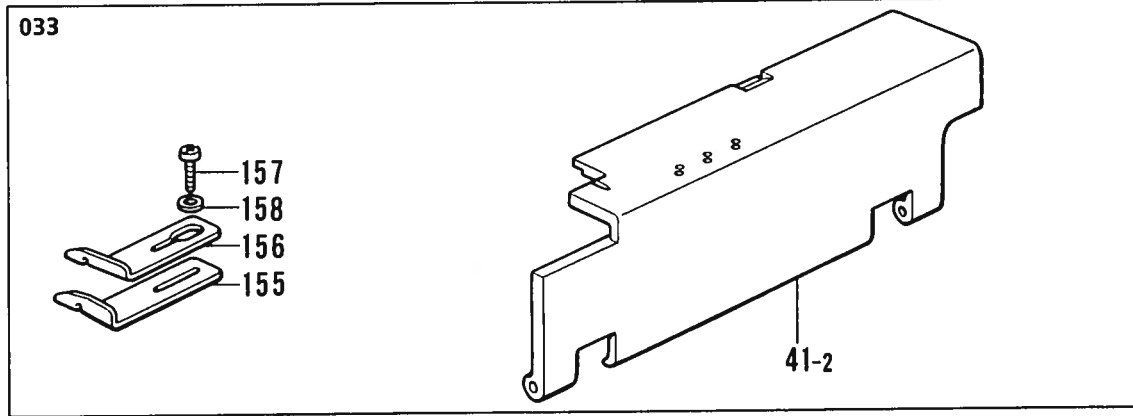
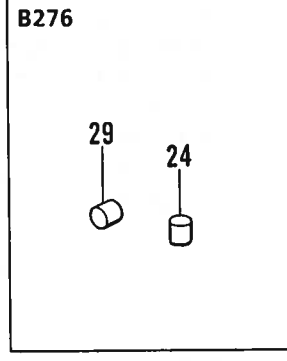
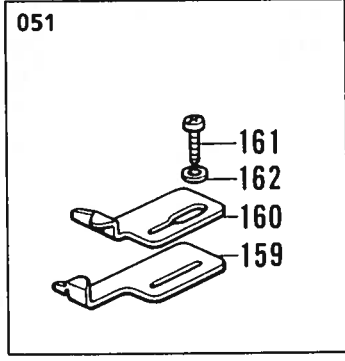
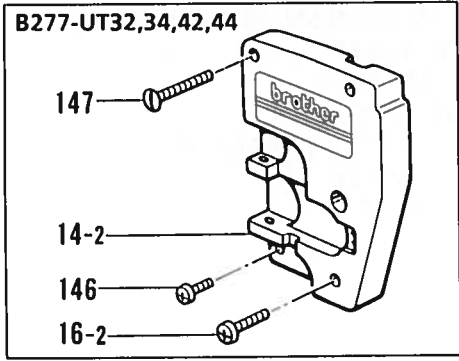

118-276,277-052

B. 針冷却関係 / Needle cooler / Nadelkühlungsvorrichtung /
Mécanisme du refroidisseur d'aiguille / Mecanismo del enfriador de aguja

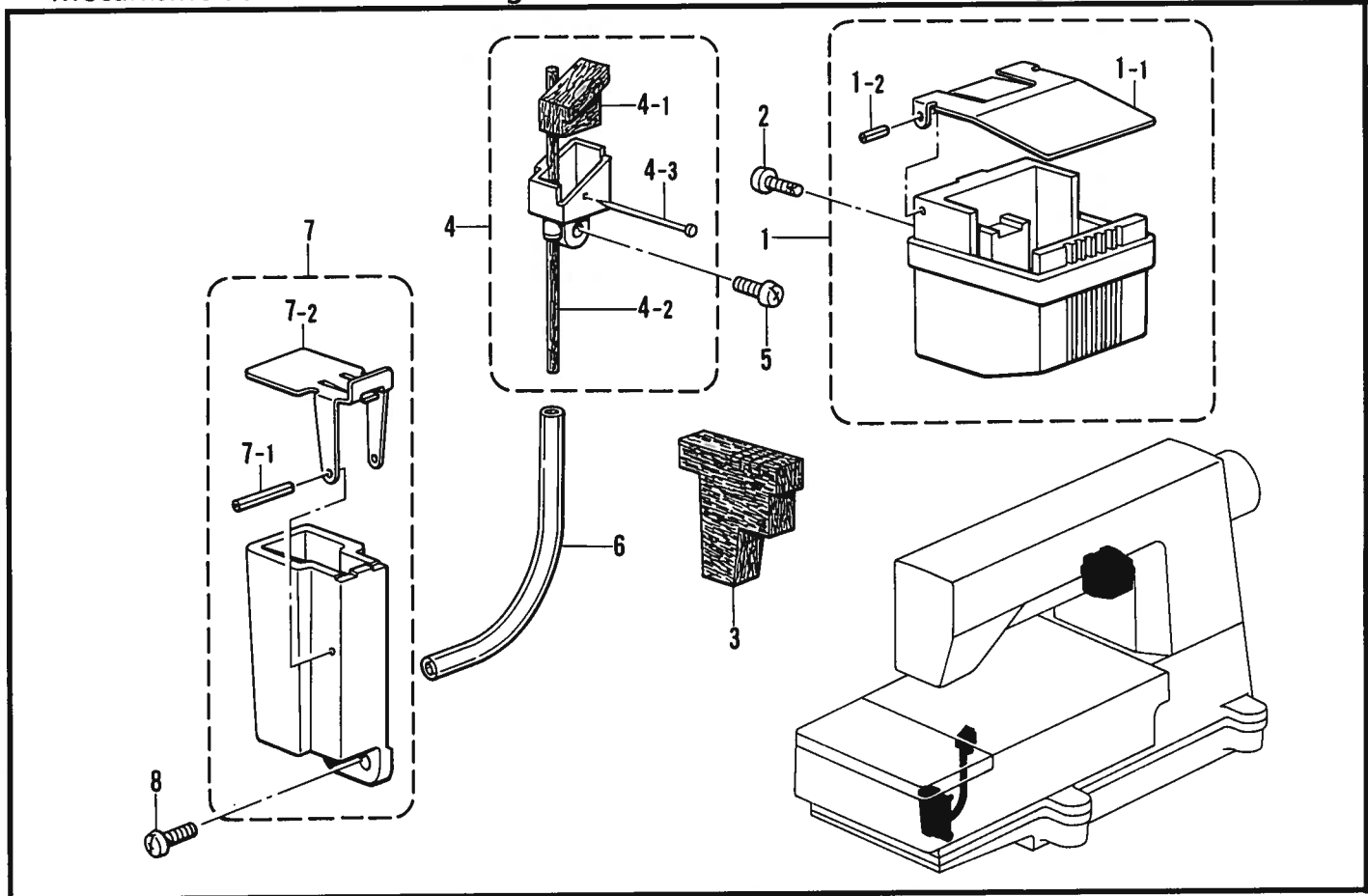

118-276,277-124

A2. 主体関係 / Machine body / Maschinengehäuse /
Corps de la machine / Cuerpo de la máquina

REF.NO.	CODE	Q'TY	ヒンメイ	NAME OF PARTS	RM
<B276>					
24	154841009	1	メクラセン	OIL CAP	
29	156887001	1	メクラセン17	OIL CAP 17	
<B277-UT32,34,42,44>(上飾り糸切り用/ FOR SPREADER THREAD TRIMMER)					
14-2	S21960001	1	メンイタ	FACE PLATE	
16-2	062681612	1	ナベコ437-40X16	SCREW, PAN M4.37-40X16	
146	062681012	1	ナベコ437-40X10	SCREW, PAN M4.37-40X10	
147	156937001	2	マルサラネジ4.37X25	SCREW, FLAT M4.37X25	
<033>(カバーリング用/ FOR COVERING)					
41-2	S21817001	1	マエカバー	FRONT COVER	
155	S21862001	1	ガイドL	GUIDE (L)	
156	S21863001	1	ガイドR	GUIDE (R)	
157	062710812	2	ナベコ476-32X8	SCREW, PAN M4.76-32X8	
158	148847001	2	ザガネ	WASHER	
<051>(ヘム縫い用/ FOR HEM STITCHING)					
159	S21864001	1	ガイドL	GUIDE (L)	
160	S21865001	1	ガイドR	GUIDE (R)	
161	062710812	2	ナベコ476-32X8	SCREW, PAN M4.76-32X8	
162	148847001	2	ザガネ	WASHER	

118-276,277-052

B. 針冷却関係 / Needle cooler / Nadelkühlungsvorrichtung /

Mécanisme du refroidisseur d'aiguille / Mecanismo del enfriador de aguja

REF.NO.	CODE	Q'TY	ヒンメイ	NAME OF PARTS	RM
1	S08758009	1	ハリイトレイキヤクタンククミ	NEEDLE THREAD COOLER TANK ASSY	
1-1	S08760009	1	ハリイトレイキヤクタンクフタ	NEEDLE THREAD COOLER TANK COVER	
1-2	047200642	2	スプリングピンAW2	PIN, SPRING ROLL AW2	
2	575456001	2	+ナベPタイト3X10	TAPTITE, PAN P M3X10	
3	S08761100	1	ハリイトレイキヤクフェルト	FELT	
4	S08762101	1	フェルトササエクミ	FELT SUPPORT ASSY	
4-1	S08764100	1	フェルトS	FELT (S)	
4-2	S08765000	1	フェルト	FELT	
4-3	S02874001	1	ムシピン	PIN	
5	062670812	2	ナベコ3.57-40X8	SCREW, PAN M3.57-40X8	
6	S08766000	1	ビニルチューブ	OIL TUBE	
7	154943001	1	ハリレイキヤクタンククミ	NEEDLE COOLER TANK ASSY	
7-1	047201640	1	スプリングピンAW2	PIN, SPRING ROLL AW2	
7-2	154945001	1	ハリレイキヤクタンクフタ	NEEDLE COOLER TANK COVER	
8	062670812	2	ナベコ3.57-40X8	SCREW, PAN M3.57-40X8	

118-276,277-124

C. 上軸・針棒関係 / Upper shaft and needle bar mechanism / Obere Welle und Nadelstangenvorrichtung / Mécanisme de arbre supérieur et barra à aiguille / Mecanismo del eje superior y la barra de aguja

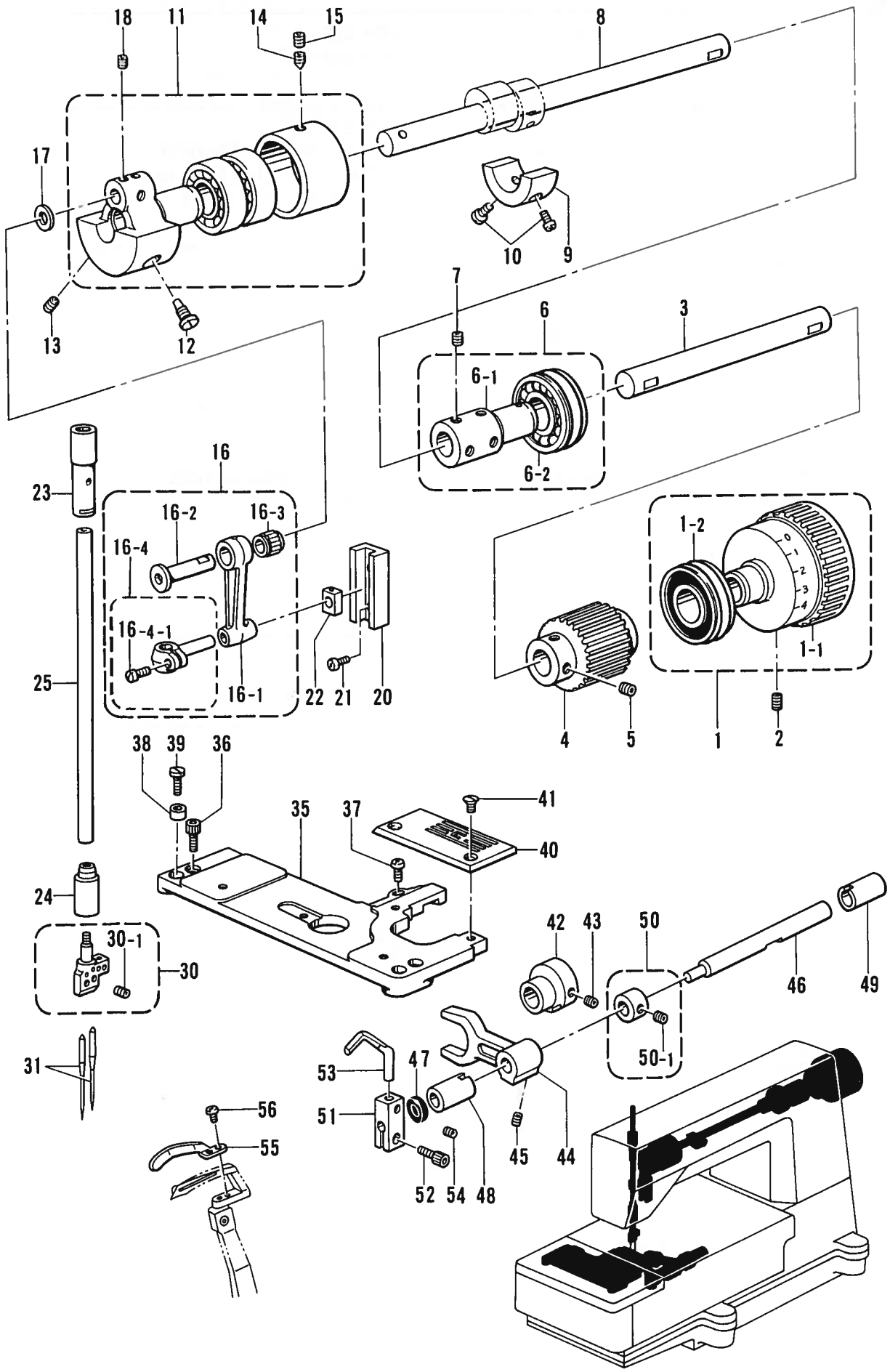

C. 上軸・針棒関係 / Upper shaft and needle bar mechanism / Obere Welle und Nadelstangenvorrichtung / Mécanisme de arbre supérieur et barra à aiguille / Mecanismo del eje superior y la barra de aguja

REF.NO.	CODE	Q'TY	ヒンメイ	NAME OF PARTS	RM
1	S21821009	1	プーリクミ	PULLEY ASSY	
1-1	S21822009	1	プーリ	PULLEY	
1-2	S14621001	1	タマジクウケ6204LLB	BALL BEARING, 6204LLB	
2	014770622	2	アナトメネジ6.35クボミ	SET SCREW, SOCKET (CP) M6.35	
3	S08682001	1	ウワジクR	UPPER SHAFT (R)	
4	S08683000	1	タイミングプーリU	TIMING PULLEY (U)	
5	014770622	4	アナトメネジ6.35クボミ	SET SCREW, SOCKET (CP) M6.35	
6	S08684101	1	ツギテLクミ	JOINT (L) ASSY	
6-1	S08685001	1	ツギテL	JOINT (L)	
6-2	S08686101	1	タマジクウケ6204LU	BALL BEARING, 6204LU	
7	014770622	4	アナトメネジ6.35クボミ	SET SCREW, SOCKET (CP) M6.35	
8	S08687001	1	ウワジクL	UPPER SHAFT (L)	
9	S08688001	1	ウエイト	WEIGHT	
10	062711012	2	ナベコ476-32X10	SCREW, PAN M4.76-32X10	
11	S08689001	1	テンピンクラククミ	NEEDLE BAR CRANK ASSY	
12	104464001	1	シメネジ7.14	SCREW, M7.14	
13	014770622	1	アナトメネジ6.35クボミ	SET SCREW, SOCKET (CP) M6.35	
14	118853001	1	アナトメネジ5.95	SET SCREW, SOCKET M5.95	
15	014760622	1	アナトメネジ5.95	SET SCREW, SOCKET (CP) M5.95	
16	S08692101	1	ハリボウレンカンクミ	THREAD TAKE-UP LEVER ASSY	
16-1	S08693001	1	ハリボウレンカン	THREAD TAKE-UP LEVER	
16-2	S08694001	1	ハリボウレンカンジク	THREAD TAKE-UP LEVER SHAFT	
16-3	S09120001	1	ニードルジクウケ	NEEDLE ROLLER BEARING	
16-4	S30086001	1	ハリボウダキクミ	NEEDLE BAR CLAMP ASSY	
16-4-1	100064005	1	シメネジ3.57	SCREW, M3.57	
17	107153001	1	ザガネ	WASHER	
18	014760622	3	アナトメネジ5.95	SET SCREW, SOCKET (CP) M5.95	
20	145688000	1	ハリボウアンナイ	NEEDLE BAR GUIDE	
21	062670612	2	ナベコ357-40X6	SCREW, PAN M3.57-40X6	
22	102630001	1	ハリボウアンナイカクコマ	NEEDLE BAR GUIDE SLIDE BLOCK	
23	S08696000	1	ハリボウメタルU	NEEDLE BAR BUSH (U)	
24	S08697000	1	ハリボウメタルD	NEEDLE BAR BUSH (D)	
25	S08698001	1	ハリボウ	NEEDLE BAR	
30	※	1	ハリドメクミ	NEEDLE CLAMP ASSY	
35	S08716201	1	ハリイタササエイタ	NEEDLE PLATE SUPPORT PLATE	
36	018681022	2	アナボルト4.37X10	BOLT, SOCKET M4.37X10	
37	062680812	1	ナベコ437-40X8	SCREW, PAN M4.37-40X8	
38	S09124001	2	ハリイタササエイタカラー	COLLER	
39	S13385001	2	シメネジ3.57X10	SCREW, M3.57X10	
40	※	1	ハリイタ	NEEDLE PLATE	
41	S09121001	2	マルサラネジ3.57X6	SCREW, FLAT M3.57X6	
42	S08750001	1	ハリウケBヘンシンリン	NEEDLE GUARD REAR ECCENTRIC WHEEL	
43	014680622	2	アナトメネジ4.37クボミ	SET SCREW, SOCKET (CP) M4.37	
44	S08751001	1	ハリウケBレバー	NEEDLE GUARD REAR LEVER	
45	014680622	2	アナトメネジ4.37クボミ	SET SCREW, SOCKET (CP) M4.37	
46	S08752001	1	ハリウケBジク	NEEDLE GUARD REAR SHAFT	
47	155539000	1	ダストシール	DUST SEAL	
48	S08753000	1	ハリウケBジクメタルL	NEEDLE GUARD SHAFT BUSH (L)	
49	S08754000	1	ハリウケBジクメタルR	NEEDLE GUARD SHAFT BUSH (R)	
50	S03704001	1	セツトカラークミ	SET COLLAR ASSY	
50-1	014770622	2	アナトメネジ6.35クボミ	SET SCREW, SOCKET (CP) M6.35	
51	S08755001	1	ハリウケBトリツケダイ	NEEDLE GUARD REAR SET BRACKET	
52	018681022	1	アナボルト4.37X10	BOLT, SOCKET M4.37X10	
53	S08756001	1	ハリウケB	NEEDLE GUARD REAR	
54	014680422	1	アナトメネジ4.37クボミ	SET SCREW, SOCKET (CP) M4.37	
55	S08757001	1	イトウケ	THREAD GUARD	
56	060630312	1	バインド238-56X3	SCREW, BIND M2.38-56X3	
<-1,-2,-3,-4,-5> <二本針用 / FOR 2 NEEDLES>					
30-1	146427001	2	アナトメネジ3.18クボミ	SET SCREW, SOCKET (CP) M3.18	
31	S08715010	2	ミシンハリUYX128GAS	NEEDLE UYX128GAS	
<-6,-7,-8> <三本針用 / FOR 3 NEEDLES>					
30-1	146427001	3	アナトメネジ3.18クボミ	SET SCREW, SOCKET (CP) M3.18	
31	S08715010	3	ミシンハリUYX128GAS	NEEDLE UYX128GAS	

D. 押工関係 / Presser foot mechanism / Stoffdrückerfuß /
 Mécanisme de pied presseur / Mecanismo de la prensa tela

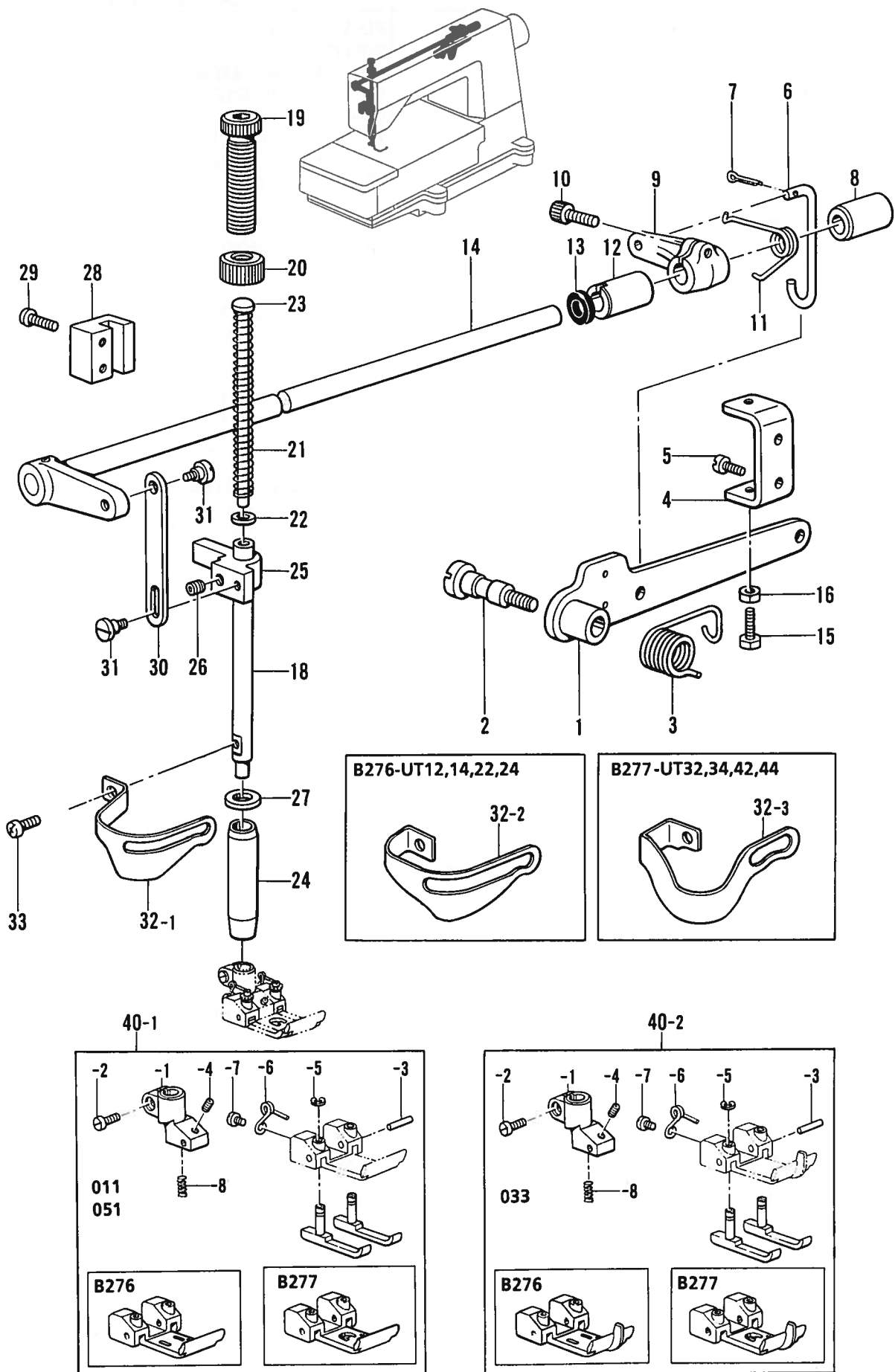

D. 押工関係 / Presser foot mechanism / Stoffdrückerfuß /
 Mécanisme de pied presseur / Mecanismo de la prensa tela

REF.NO.	CODE	Q'TY	ヒンメイ	NAME OF PARTS	RM
1	S21829001	1	オサエアゲレバーR	PRESSER BAR LIFTER LEVER (R)	
2	S21830001	1	ダンネジ7.94	STUD SCREW, M7.94	
3	143325001	1	オサエアシアゲレバーバネ	SPRING	
4	146522101	1	レバーチヨウセツイタ	LEVER ADJUST PLATE	
5	060680712	2	バインド437-40X7	SCREW, BIND M4.37-40X7	
6	S08769001	1	オサエアゲリンク	PRESSER BAR LIFTER LINK	
7	110793001	1	ワリピン	PIN, COTTER	
8	155220000	1	ホジヨアツメタルR	AUTO PRESSER ARM BUSH (R)	
9	154956001	1	オサエアシアゲMレバー	PRESSER FOOT LIFTER INSIDE LEVER	
10	018771432	1	アナボルト635-40X14	BOLT, SOCKET M6.35-40X14	
11	154957001	1	オサエアゲMレバーバネ	SPRING	
12	S08770000	1	ジクメタル	SHAFT BUSH	
13	155539000	1	ダストシール	DUST SEAL	
14	S08771001	1	オサエアゲレバーLクミ	PRESSER BAR LIFTER LEVER (L) ASSY	
15	017711612	1	ボルト4.76X16	BOLT, M4.76X16	
16	110161006	1	ナツト4.76	NUT, M4.76	
18	S08774001	1	オサエボウ	PRESSER BAR	
19	S31012001	1	オサエチヨウセツネジ	ADJUST SCREW	
20	S31013001	1	チヨウセツネジツマミナツト	NUT	
21	141728001	1	オサエバネ	SPRING	
22	140407001	1	ザガネ	WASHER	
23	141208001	1	オサエバネアンナイ	SPRING GUIDE	
24	145472001	1	オサエボウメタル	PRESSER BAR BUSH	
25	S00879001	1	オサエボウダキ	PRESSER BAR CLAMP	
26	014760622	1	アナトメネジ5.95	SET SCREW, SOCKET (CP) M5.95	
27	154596000	1	イトキリカムレバークツシヨン	CUSHION	
28	S08775000	1	オサエボウアンナイ	PRESSER BAR GUIDE	
29	062681412	2	ナベコ437-40X14	SCREW, PAN M4.37-40X14	
30	S08776001	1	オサエアゲイタ	PRESSER BAR LIFTER PLATE	
31	S08777001	2	ダンネジ4.37	STUD SCREW, M4.37	
32-1	S28798001	1	フィンガーガードA	FINGER GUARD (A)	
33	062670812	1	ナベコ3.57-40X8	SCREW, PAN M3.57-40X8	
<B276-UT12,14,22,24>(※払い用 / FOR THREAD WIPER)					
32-2	S28800001	1	フィンガーガードC	FINGER GUARD (C)	
<B277-UT32,34,42,44>(上飾り糸切り用 / FOR UPPER THREAD TRIMMER)					
32-3	S28801001	1	フィンガーガードB	FINGER GUARD (B)	
<011,051><地縫・ヘム縫用 / FOR PLAIN STITCHING AND HEM STITCHING>					
40-1	※	1	オサエクミ	PRESSER FOOT ASSY	
40-1-1	S08782101	1	オサエシジタイ	PRESSER FOOT BASE	
40-1-2	100064005	1	シメネジ3.57	SCREW, M3.57	
40-1-3	S08783101	1	オサエピン	PIN	
40-1-4	S01374001	1	トメネジ2.38クボミ	SET SCREW, (CP) M2.38	
40-1-5	048020342	2	トメワE2	RETAINING RING, E2	
40-1-6	S08784001	2	オサエバネ	SPRING	
40-1-7	062660512	2	ナベコネジ318-40X5	SCREW, PAN M3.18-40X5	
40-1-8	S08785001	1	オシバネ	SPRING	
<033><カバーリング用 / FOR COVERING>					
40-2	※	1	オサエクミ	PRESSER FOOT ASSY	
40-2-1	S08782101	1	オサエシジタイ	PRESSER FOOT BASE	
40-2-2	100064005	1	シメネジ3.57	SCREW, M3.57	
40-2-3	S08783101	1	オサエピン	PIN	
40-2-4	S01374001	1	トメネジ2.38クボミ	SET SCREW, (CP) M2.38	
40-2-5	048020342	2	トメワE2	RETAINING RING, E2	
40-2-6	S08784001	2	オサエバネ	SPRING	
40-2-7	062660512	2	ナベコネジ318-40X5	SCREW, PAN M3.18-40X5	
40-2-8	S08785001	1	オシバネ	SPRING	

E. 送り関係 / Feed mechanism / Transportvorrichtung /
 Mécanisme de l'entraînement / Mecanismo de la alimentación

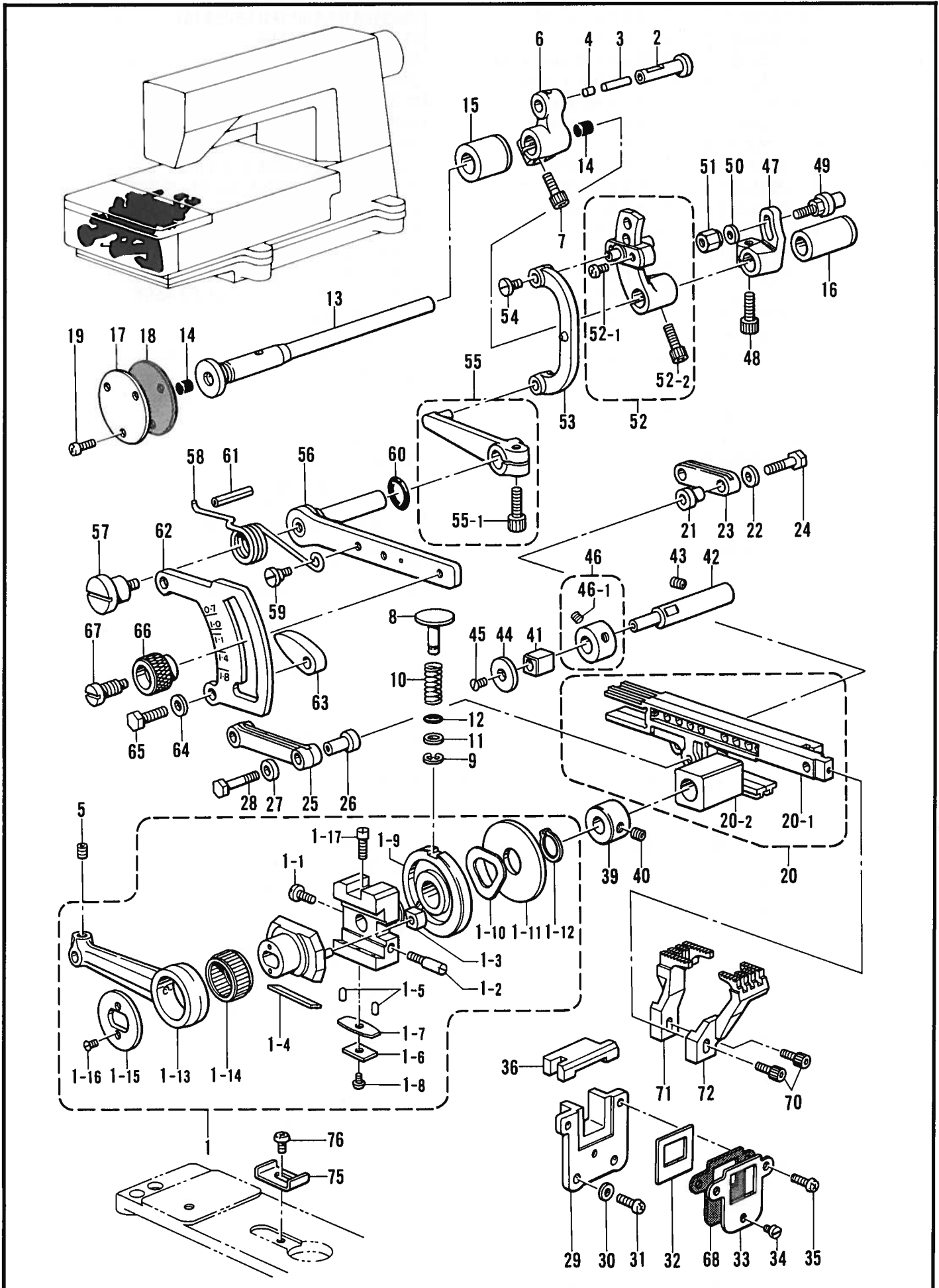

E. 送り関係 / Feed mechanism / Transportvorrichtung /
Mécanisme de l'entraînement / Mecanismo de la alimentación

REF.NO.	CODE	Q'TY	ヒンメイ	NAME OF PARTS	RM
1	146528102	1	ヘンシンリンクミ	ECCENTRIC WHEEL ASSY	
1-1	S16498001	1	シメネジ4.37	SCREW, M4.37	
1-2	145663001	1	トメネジ4.37	SET SCREW, M4.37	
1-3	140165001	1	チヨウセツピンカクコマ	SLIDE BLOCK	
1-4	146401001	1	ジブ	GIB	
1-5	146402001	2	ジブオサエピン	PIN	
1-6	146403001	1	ジブオサエイタバネS	PLATE SPRING (S)	
1-7	146404001	1	ジブオサエイタバネL	PLATE SPRING (L)	
1-8	062660512	1	ナベコネジ318-40X5	SCREW, PAN M3.18-40X5	
1-9	144053001	1	ヘンシンチヨウセツカムクミ	ECCENTRIC WHEEL ADJUST CAM ASSY	
1-10	144055001	1	ナミバネ	WAVE SPRING	
1-11	146529001	1	ザガネ	WASHER	
1-12	048150143	1	トメワジクヨウC15	RETAINING RING, C15	
1-13	146530001	1	オクリロッド	FEED ROD	
1-14	146531001	1	ニードルジクウケ20	NEEDLE ROLLER BEARING 20	
1-15	140176001	1	オクリロッドオサエイタ	FEED ROD PRESSER PLATE	
1-16	117517003	2	サラネジ2.38	SCREW, FLAT M2.38	
1-17	100025002	2	シメネジ4.76	SCREW, M4.76	
2	146532001	1	オクリロッドピン	FEED ROD PIN	
3	147318000	1	ピン	PIN	
4	140326009	1	ゴムセン	OIL CAP	
5	100251001	1	トメネジ6.35	SET SCREW, M6.35	
6	146533001	1	オクリウデ	FEED ARM	
7	018771432	1	アナボルト635-40X14	BOLT, SOCKET M6.35-40X14	
8	S08870001	1	プツシュボタン	PUSH BUTTON	
9	048040342	1	トメワE4	RETAINING RING, E4	
10	S08871001	1	ボタンジクバネ	SPRING	
11	153484001	1	ザガネ4.76	WASHER, M4.76	
12	081003670	1	OリングPW3	O RING,PW3	
13	146538001	1	オクリジク	FEED SHAFT	
14	140327001	2	ゴムセン	OIL CAP	
15	146539000	1	オクリジクメタルL	FEED SHAFT BUSH (L)	
16	146540000	1	オクリジクメタルR	FEED SHAFT BUSH (R)	
17	155144001	1	オクリジクメタルLフタ	FEED SHAFT BUSH (L) CAP	
18	155145000	1	パツキン	PACKING	
19	062670812	3	ナベコ3.57-40X8	SCREW, PAN M3.57-40X8	
20	S08872001	1	オクリダイカクゴマクミ	FEED BAR SLIDE BLOCK ASSY	
20-1	S08873001	1	オクリダイクミ	FEED BAR ASSY	
20-2	146544000	1	ジヨウゲオクリカクゴマ	FEED LIFTING SLIDE BLOCK	
21	140207001	1	シユオクリリンクブシュ	MAIN FEED LINK BUSH	
22	S23359001	1	ザガネ	WASHER	
23	140209001	1	シユオクリリンク	MAIN FEED LINK	
24	140210001	1	シユオクリリンクジクS	MAIN FEED LINK SHAFT (S)	
25	146554001	1	サドウオクリリンク	DIFFERENTIAL FEED LINK	
26	146555001	1	サドウオクリリンクブシュ	DIFFERENTIAL FEED LINK BUSH	
27	S23359001	1	ザガネ	WASHER	
28	140217001	1	オクリリンクジクL	FEED LINK SHAFT (L)	
29	155151000	1	オクリダイアンナイ	FEED BAR GUIDE	
30	100645003	2	ザガネ	WASHER	
31	062681012	2	ナベコ437-40X10	SCREW, PAN M4.37-40X10	
32	155177100	1	ボウジンイタ	FRAGMENT PROTECTOR PLATE	
33	155178001	1	ボウジンイタササエ	FRAGMENT PROTECTOR SUPPORT	
34	S01297001	1	シメネジ3.57X3.5	SCREW, M3.57X3.5	
35	062681012	2	ナベコ437-40X10	SCREW, PAN M4.37-40X10	
36	S08876000	1	オクリダイボウジンタイ	FEED BAR FRAGMENT PROTECTOR BASE	
39	146741000	1	セツトカラー	SET COLLAR	
40	101706001	1	トメネジ6.35	SET SCREW, M6.35	
41	146547000	1	オクリダイカクゴマ	FEED BAR SLIDE BLOCK	
42	146548101	1	オクリダイカクゴマジク	FEED BAR SLIDE BLOCK SHAFT	

E. 送り関係 / Feed mechanism / Transportvorrichtung /
 Mécanisme de l'entraînement / Mecanismo de la alimentación

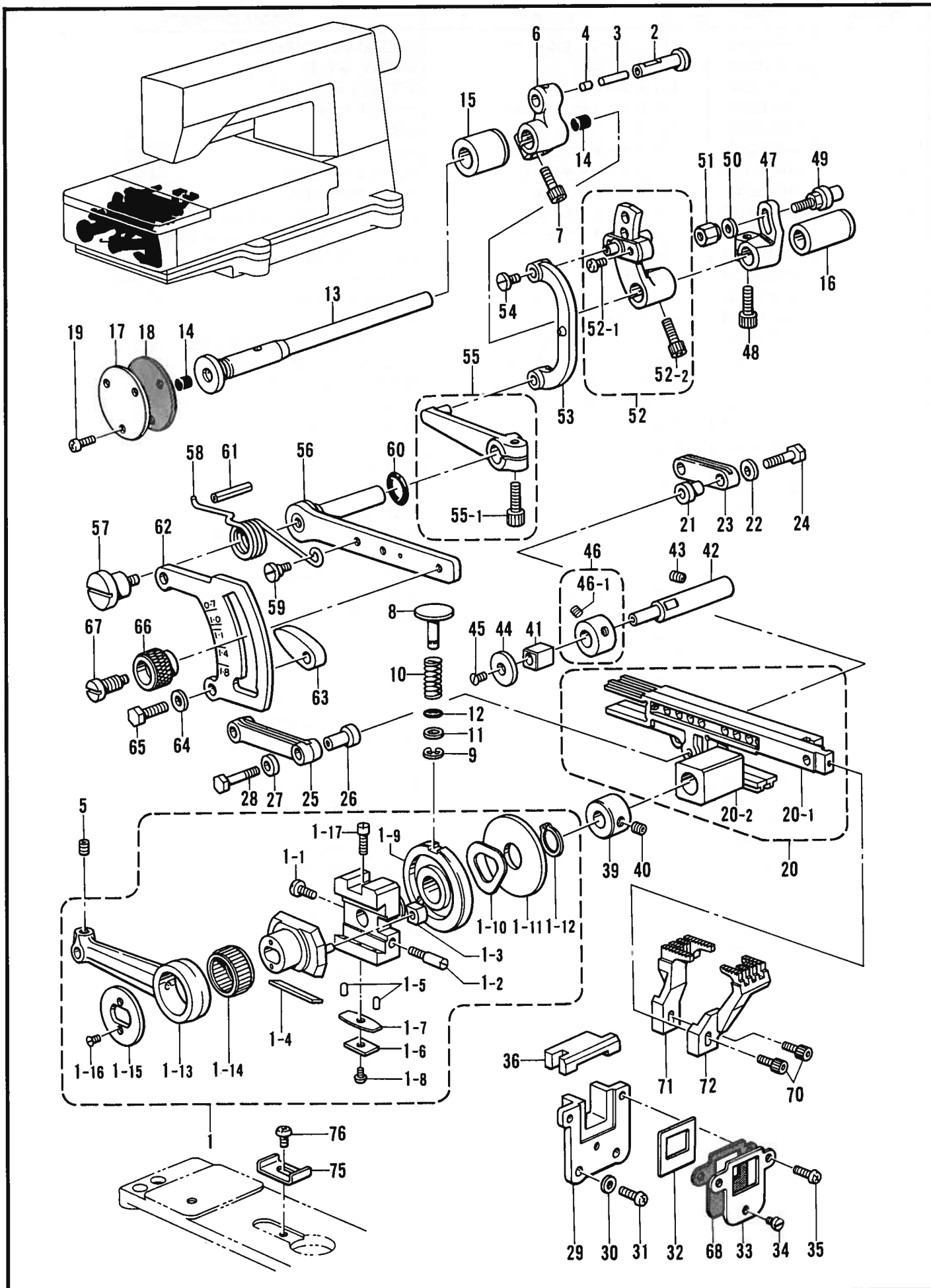

E. 送り関係 / Feed mechanism / Transportvorrichtung /
Mécanisme de l'entraînement / Mecanismo de la alimentación

REF.NO.	CODE	Q'TY	ヒンメイ	NAME OF PARTS	RM
43	014780622	1	アナトメネジ6.35クボミ	SET SCREW, SOCKET (CP) M6.35	
44	S08877001	1	オクリダイカクゴマアテイタ	SLIDE PLATE	
45	107272002	1	サラネジ4.37	SCREW, FLAT M4.37	
46	S03704001	1	セットカラークミ	SET COLLAR ASSY	
46-1	014770622	2	アナトメネジ6.35クボミ	SET SCREW, SOCKET (CP) M6.35	
47	140205001	1	シュオクリウデ	MAIN FEED ARM	
48	018771432	1	アナボルト635-40X14	BOLT, SOCKET M6.35-40X14	
49	143564001	1	シュオクリジク	MAIN FEED SHAFT	
50	113431002	1	ザガネ	WASHER	
51	143565001	1	ナツト4.76	NUT, M4.76	
52	S08878001	1	サドウオクリウデクミ	DIFFERENTIAL FEED ARM ASSY	
52-1	062660712	2	ナベコ318-40X7	SCREW, PAN M3.18-40X7	
52-2	018771432	1	アナボルト635-40X14	BOLT, SOCKET M6.35-40X14	
53	146556001	1	サドウリンク	DIFFERENTIAL FEED ADJUST LINK	
54	148834001	1	シメネジ3.57	SCREW, M3.57	
55	S08879001	1	リンクレバーネジツキ	DIFFERENTIAL FEED LINK LEVER WITH SCREW	
55-1	018771432	1	アナボルト635-40X14	BOLT, SOCKET M6.35-40X14	
56	S08880001	1	サドウチヨウセツレバー	DIFFERENTIAL FEED ADJUST LEVER	
57	146559001	1	ダンネジ5.56	STUD SCREW, M5.56	
58	146560101	1	レバーバネ	LEVER SPRING	
59	100294002	1	ダンネジ4.76	STUD SCREW, M4.76	
60	109203001	1	リング	O RING	
61	047502242	1	スプリングピンAW5	PIN, SPRING ROLL AW5	
62	S08881101	1	サドウリヨウメモリイタ	DIFFERENTIAL STITCH CONTROL PLATE	
63	146563001	2	チヨウセツレバーストツバ	STOPPER FOR DIFFERENTIAL STITCH CONTROL	
64	025770232	2	ヒラザガネチユウ6.35	WASHER, PLAIN M 6.35	
65	017781412	2	ボルト6.35X14	BOLT, M6.35X14	
66	155175001	1	セットネジツマミ	SET SCREW KNOB	
67	155176001	1	セットネジ	SET SCREW	
68	S08467000	1	パツキン	PACKING	
70	154965001	2	アナボルト3.57X8	BOLT, SOCKET M3.57X8	
71	※	1	シュオクリバ	MAIN FEED DOG	
72	※	1	サドウオクリバ	DIFFERENTIAL FEED DOG	
75	S16249001	1	プツシュボタンストツバ	PUSH BUTTON STOPPER	
76	060680512	1	バインド437-40X5	SCREW, BIND M4.37-40X5	

F. 下軸関係 / Lower shaft mechanism / Untere Welle /
 Mécanisme de l'arbre inférieur / Mecanismo del eje inferior

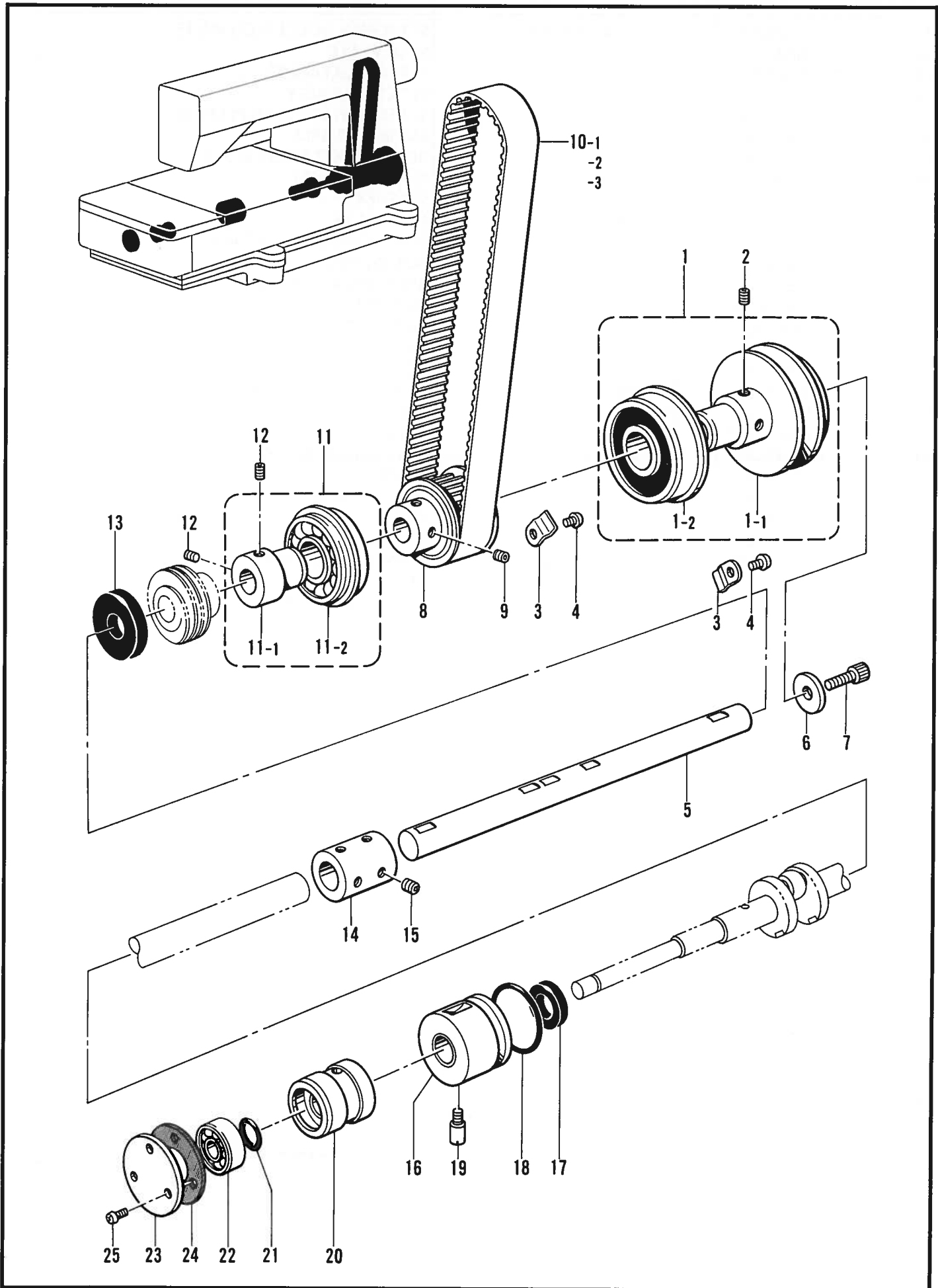

F. 下軸関係 / Lower shaft mechanism / Untere Welle /
Mécanisme de l'arbre inférieur / Mecanismo del eje inferior

REF.NO.	CODE	Q'TY	ヒンメイ	NAME OF PARTS	RM
1	S08889101	1	Vベルトプーリクミ	V-BELT PULLEY ASSY	
1-1	S08890001	1	Vベルトプーリ	V-BELT PULLEY	
1-2	S14622001	1	タマジクウケ6304VV	BALL BEARING, 6304VV	
2	014780622	2	アナトメネジ6.35クボミ	SET SCREW, SOCKET (CP) M6.35	
3	153734001	2	アームササエイタバネ	SPRING, PLATE	
4	062680612	2	ナベコ4.37-40X6	SCREW, PAN M4.37-40X6	
5	S08891001	1	シタジクR	LOWER SHAFT (R)	
6	154886001	1	ザガネ	WASHER	
7	018771432	1	アナボルト635-40X14	BOLT, SOCKET M6.35-40X14	
8	S08892001	1	タイミングプーリDクミ	TIMING PULLEY (D) ASSY	
9	014770622	2	アナトメネジ6.35クボミ	SET SCREW, SOCKET (CP) M6.35	
10-1	★ S08895001	1	タイミングベルト	TIMING BELT	
10-2	★ S08895002	1	タイミングベルト	TIMING BELT	
10-3	★ S08895003	1	タイミングベルト	TIMING BELT	
11	S08896101	1	タマジクウケクミ	BALL BEARING ASSY	
11-1	S08897001	1	タマジクウケブシユ	BALL BEARING BUSH	
11-2	S14623001	1	タマジクウケ6204DV	BALL BEARING, 6204DV	
12	014770622	2	アナトメネジ6.35クボミ	SET SCREW, SOCKET (CP) M6.35	
13	S08898000	1	オイルシール	OIL SEAL	
14	S08899001	1	ジクツギテ	SHAFT JOINT	
15	014770622	4	アナトメネジ6.35クボミ	SET SCREW, SOCKET (CP) M6.35	
16	S08900000	1	クランクジクメタルRクミ	LOWER SHAFT BUSH (R) ASSY	
17	S08903000	1	ダストシール	DUST SEAL	
18	081032870	1	OリングS32	O RING, S32	
19	S08967001	1	シメネジ4.76	SCREW, M4.76	
20	S08904000	1	クランクジクメタルLクミ	CRANK SHAFT BUSH (L) ASSY	
21	114294001	1	Oリング	O RING	
22	072600000	1	タマジクウケ6000	BALL BEARING, 6000	
23	143311001	1	ベアリングフタ	BEARING COVER	
24	143312000	1	ベアリングフタバツキン	BEARING COVER PACKING	
25	062670812	3	ナベコ3.57-40X8	SCREW, PAN M3.57-40X8	

★印はアームベッド上面のテーキンに合わせてご選択下さい。(取扱説明書タイミングベルト交換の仕方をご参照ください。)

Select parts marked with a star (★) according to the index on the arm bed top. (Refer to timing belt replacement in the instruction manual.)

Die mit dem Zeichen (★) markierten Teile entsprechend dem an der Oberseite des Armbetts angegebenen Index auswählen. (Siehe Ersetzen des Synchronriemens in der Bedienungsanleitung.)

Sélectionner les pièces indiquées par une étoile (★) selon l'index situé sur le plateau du bras. (Se reporter à la section du manuel d'instructions concernant le remplacement de la courroie de synchronisation.)

Las piezas marcadas con un asterisco (★) se deben seleccionar de acuerdo al índice de la parte superior de la mesa del brazo. (Consultar la sección sobre el cambio de la correa de distribución en el manual de instrucciones.)

G. ルーパー関係 / Looper mechanism / Greifer /
 Mécanisme des griffes / Mecanismo del presilladora

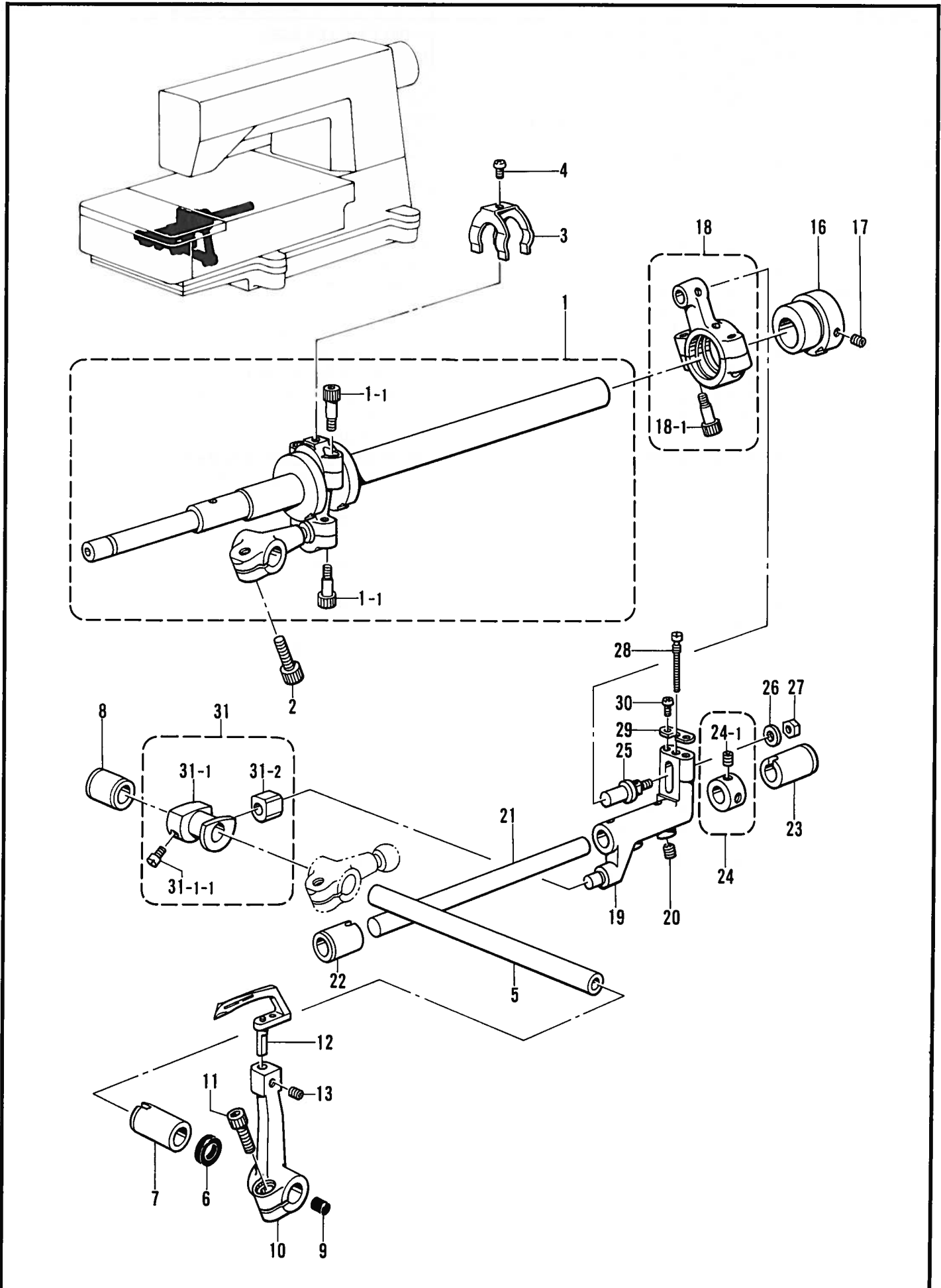

G. ルーパー関係 / Looper mechanism / Greifer /
Mécanisme des griffes / Mecanismo del presilladora

REF.NO.	CODE	Q'TY	ヒンメイ	NAME OF PARTS	RM
1	S08906001	1	ルーパー crank ジッククミ	LOOPER CRANK SHAFT ASSY	
1-1	148425001	4	アナボルト 4.37X14	BOLT, SOCKET M4.37X14	
2	018771432	1	アナボルト 635-40X14	BOLT, SOCKET M6.35-40X14	
3	110704001	1	ウワルーパ ロッド フレドメ	LOOPER CONNECTING ROD STOPPER	
4	062660412	1	ナベコ 318-40X4	SCREW, PAN M3.18-40X4	
5	S08910001	1	ルーパー ジック	LOOPER SHAFT	
6	155539000	1	ダスト シール	DUST SEAL	
7	S08770000	1	ジック メタル	SHAFT BUSH	
8	S08911000	1	ルーパー ジック メタル B	LOOPER SHAFT BUSHING (B)	
9	140327001	1	ゴム セン	OIL CAP	
10	S08912001	1	ルーパー ホルダー	LOOPER HOLDER	
11	018771432	1	アナボルト 635-40X14	BOLT, SOCKET M6.35-40X14	
12	S21866001	1	ルーパー	LOOPER	
13	014680422	1	アナトメ ネジ 4.37クボミ	SET SCREW, SOCKET (CP) M4.37	
16	S08914001	1	ゼンゴ ヘンシン リン	LONGITUDINAL ECCENTRIC CAM	
17	014680622	2	アナトメ ネジ 4.37クボミ	SET SCREW, SOCKET (CP) M4.37	
18	146624101	1	ゼンゴ ロッド クミ	LONGITUDINAL FEED ROD ASSY	
18-1	148425001	2	アナボルト 4.37X14	BOLT, SOCKET M4.37X14	
19	S08915001	1	ゼンゴ レバー	LONGITUDINAL LEVER	
20	014770622	2	アナトメ ネジ 6.35クボミ	SET SCREW, SOCKET (CP) M6.35	
21	S08916001	1	ゼンゴ レバー ジック	LONGITUDINAL FEED SHAFT	
22	S08917000	1	レバー ジック メタル L	LONGITUDINAL FEED SHAFT BUSH (L)	
23	S08754000	1	ハリウケ B ジック メタル R	KNIFE DRIVING SHAFT BUSH (R)	
24	S03704001	1	セツト カラー クミ	SET COLLAR ASSY	
24-1	014770622	2	アナトメ ネジ 6.35クボミ	SET SCREW, SOCKET (CP) M6.35	
25	S08918001	1	ゼンゴ ロッド ピン	PIN	
26	148847001	1	ザガネ	WASHER	
27	110161006	1	ナット 4.76	NUT, M4.76	
28	S08919001	1	ヘンシン チョウ セツ ネジ	ADJUST SCREW	
29	S08920001	1	ヘンシン トメイ タ	ECCENTRIC WHEEL STOPPER PLATE	
30	062630612	2	ナベコ 238-56X6	SCREW, PAN M2.38-56X6	
31	S08921101	1	ゼンゴ コマ クミ	LONGITUDINAL BLOCK ASSY	
31-1	S09251001	1	ゼンゴ コマ ネジ ツキ	LONGITUDINAL BLOCK WITH SCREW	
31-1-1	120990001	2	アタマ ツキ トメ ネジ 4.37	SET SCREW, M4.37	
31-2	140313001	1	ゼンゴ レバー カクゴマ	LONGITUDINAL FEED LEVER SLIDE BLOCK	

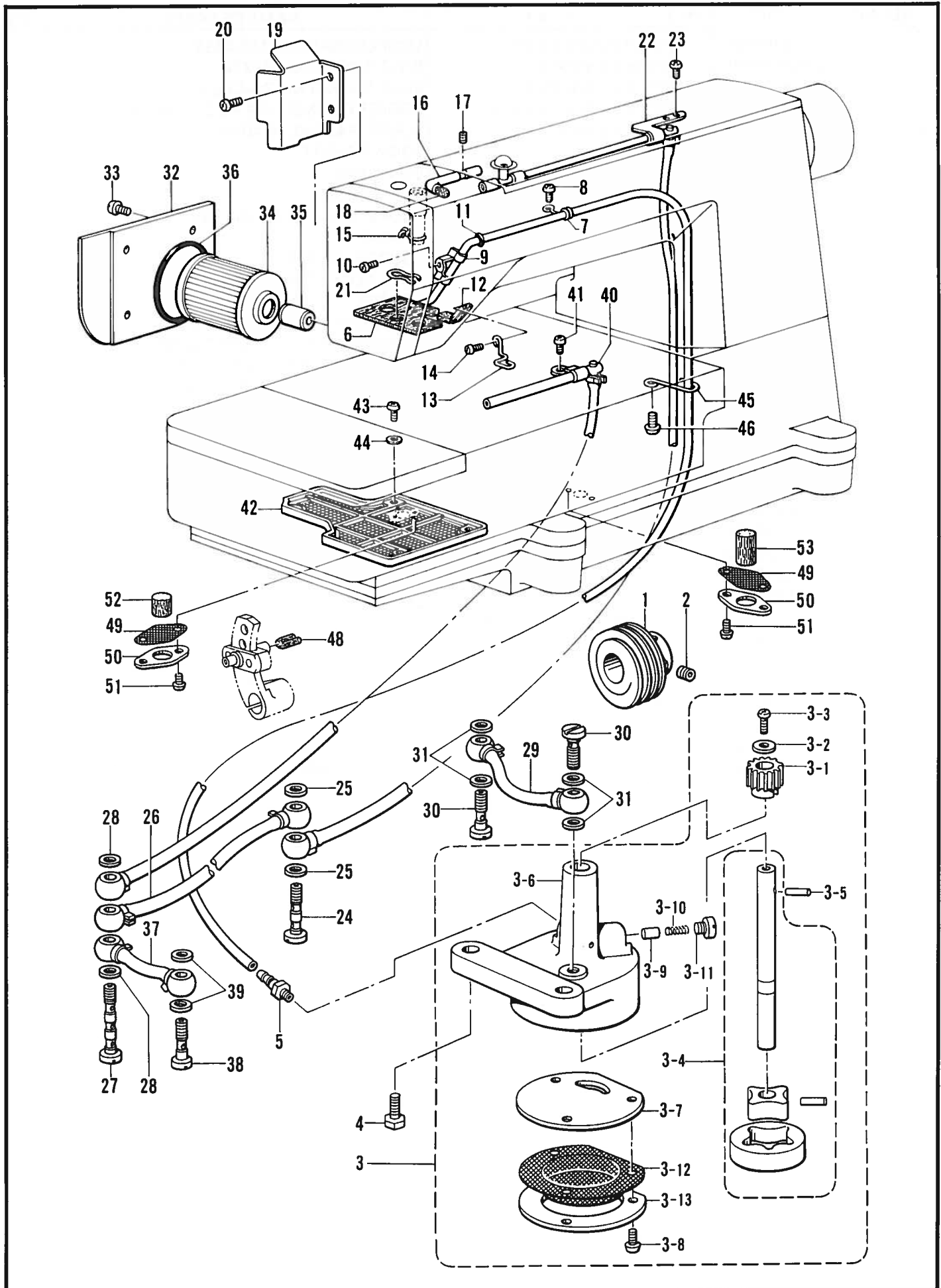

H. 給油潤滑関係 / Lubrication / Schmierung / Lubrification / Lubricación

REF.NO.	CODE	Q'TY	品名	NAME OF PARTS	RM
1	S08935001	1	ウオーム	WORM	
2	014770622	2	アナトメネジ6.35クボミ	SET SCREW, SOCKET (CP) M6.35	
3	S08936201	1	トロコイドポンプクミ	PUMP ASSY	
3-1	144619000	1	ウオームホイール	WORM WHEEL	
3-2	025350332	1	ヒラザガネダイ3.5	WASHER, PLAIN L 3.5	
3-3	062670812	1	ナベコ3.57-40X8	SCREW, PAN M3.57-40X8	
3-4	S08937101	1	ポンプロータークミ	PUMP INNER ROTER ASSY	
3-5	144622001	1	ミゾツキピンEガタ	DOWEL PIN (E)	
3-6	S08939100	1	ポンプケース	PUMP CASE	
3-7	147527000	1	ポンプフタ	PUMP COVER	
3-8	062671012	3	ナベコ357-40X10	SCREW, PAN M3.57-40X10	
3-9	144875001	1	プランジャー	PLUNGER	
3-10	144876001	1	プランジャーバネ	PLUNGER SPRING	
3-11	112467002	1	シメネジ6.35	SCREW, M6.35	
3-12	147528100	1	ロカモウ	OIL FILTER	
3-13	147529000	1	ロカモウオサエ	OIL FILTER FLANGE	
4	017781412	2	ボルト6.35X14	BOLT, M6.35X14	
5	142359001	1	オイルクチ	OIL FEEDING PIPE	
6	S08940000	1	チューブクミ	OIL TUBE ASSY	
7	112743001	1	クミヒモササエ	WICK SUPPORT	
8	062670612	1	ナベコ357-40X6	SCREW, PAN M3.57-40X6	
9	151429001	1	チューブホルダ	TUBE HOLDER	
10	062670612	1	ナベコ357-40X6	SCREW, PAN M3.57-40X6	
11	118770001	1	パツキン	PACKING	
12	S08943000	1	カクゴマフェルト	FELT	
13	S08944001	1	フェルトオサエ	FELT SUPPORT	
14	062670612	1	ナベコ357-40X6	SCREW, PAN M3.57-40X6	
15	157840000	1	クミヒモ3X3 (L = 100)	WICK 3X3 (L = 100)	
16	S08945001	1	オイルパイプ	OIL PIPE	
17	014680622	1	アナトメネジ4.37クボミ	SET SCREW, SOCKET (CP) M4.37	
18	S08946000	1	フェルト	FELT	
19	S08947001	1	オイルヨケイタ	OIL STOPPER PLATE	
20	062670612	2	ナベコ357-40X6	SCREW, PAN M3.57-40X6	
21	145737001	1	フェルトオサエ	FELT SUPPORT	
22	S08948001	1	ロッドオイルパイプUクミ	MAIN OIL PIPE (U) ASSY	
23	062670612	2	ナベコ357-40X6	SCREW, PAN M3.57-40X6	
24	112364001	1	ハイユパイプツギテネジ	OIL FEEDING PIPE JOINT SCREW	
25	159476000	2	ザガネ	WASHER	
26	S08951001	1	ビニルチューブクミ	OIL TUBE ASSY	
27	112351001	1	ハイユパイプネジ	OIL FEEDING PIPE SCREW	
28	159476000	2	ザガネ	WASHER	
29	155282101	1	ビニルチューブクミ	OIL TUBE ASSY	
30	112359001	2	ハイユパイプツギテネジ	OIL FEEDING PIPE JOINT SCREW	
31	159476000	4	ザガネ	WASHER	
32	S08955001	1	オイルフィルターフタ	OIL FILTER CAP	
33	062680812	4	ナベコ437-40X8	SCREW, PAN M4.37-40X8	
34	S08956000	1	オイルフィルター	OIL FILTER	
35	S08957001	1	オイルクチ	OIL FEEDING PIPE	
36	081044070	1	OリングP44	O RING, P44	
37	S08953001	1	ビニルチューブクミ	OIL TUBE ASSY	
38	112359001	1	ハイユパイプツギテネジ	OIL FEEDING PIPE JOINT SCREW	
39	159476000	2	ザガネ	WASHER	
40	S08958001	1	ロッドオイルパイプDクミ	MAIN OIL PIPE (D) ASSY	
41	062670612	1	ナベコ357-40X6	SCREW, PAN M3.57-40X6	
42	S09316000	1	オイルフィルターD	OIL FILTER (D)	
43	062680812	4	ナベコ437-40X8	SCREW, PAN M4.37-40X8	
44	100645003	4	ザガネ	WASHER	
45	S09125001	1	チューブガイド	OIL TUBE GUIDE	
46	062780812	1	ナベコ635-28X8	SCREW, PAN M6.35-28X8	
48	147363000	1	フェルト	FELT	
49	155294100	2	ロカモウ	OIL FILTER	
50	155295001	2	ロカモウオサエイタ	OIL FILTER FLANGE	
51	062670612	4	ナベコ357-40X6	SCREW, PAN M3.57-40X6	
52	151927001	1	クラッチフェルト	CLUTCH FELT	
53	112754001	1	フェルト	FELT	

J. スプレダー関係 / Spreader mechanism / Spreizvorrichtung /
 Mécanisme de l'étendeur / Mecanismo extendedor

B277

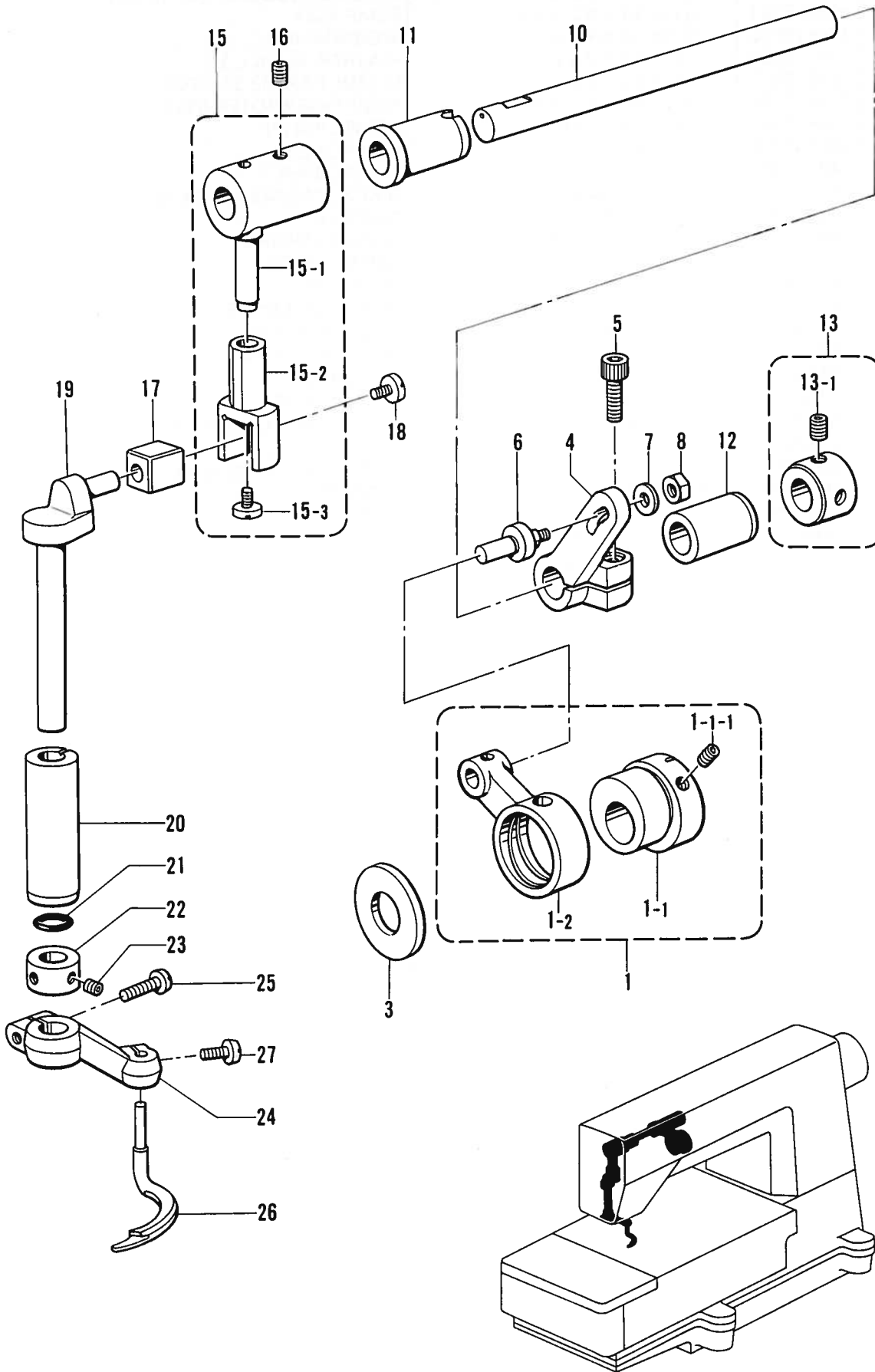

118-277-310

J. スプレダー関係 / Spreader mechanism / Spreizvorrichtung /
Mécanisme de l'étendeur / Mecanismo extendedor

REF.NO.	CODE	Q'TY	ヒンメイ	NAME OF PARTS	RM
			<B277>		
1	S08923101	1	スプレダヘンシンリンクミ	SPREADER ECCENTRIC WHEEL ASSY	
1-1	S10656001	1	ヘンシンリンネジツキ	ECCENTRIC WHEEL WITH SCREW	
1-1-1	014680622	2	アナトメネジ4.37クボミ	SET SCREW, SOCKET (CP) M4.37	
1-2	S08925000	1	スプレダロッド	SPREADER ROD	
3	101482001	1	レンカンシキリイタ	CONNECTING ROD PARTITION PLATE	
4	S08926101	1	スプレダレバーR	SPREADER LEVER (R)	
5	018771432	1	アナボルト635-40X14	BOLT, SOCKET M6.35-40X14	
6	S13809001	1	スプレダロッドピン	PIN	
7	148847001	1	ザガネ	WASHER	
8	110161006	1	ナット4.76	NUT, M4.76	
10	S08927001	1	スプレダジク	SPREADER SHAFT	
11	148196000	1	ウワメスサドウウデメタルL	SPREADER SHAFT BUSH (L)	
12	148197000	1	ウワメスサドウウデメタルR	SPREADER SHAFT BUSH (R)	
13	S03421001	1	セットカラークミ	SET COLLAR ASSY	
13-1	014770622	2	アナトメネジ6.35クボミ	SET SCREW, SOCKET (CP) M6.35	
15	S08928001	1	スプレダレバーLクミ	SPREADER LEVER (L) ASSY	
15-1	S08929001	1	スプレダレバーL	SPREADER LEVER (L)	
15-2	S08930001	1	スプレダフタマタ	SPREADER FORK	
15-3	148834001	1	シメネジ3.57	SCREW, M3.57	
16	014770622	2	アナトメネジ6.35クボミ	SET SCREW, SOCKET (CP) M6.35	
17	146547000	1	オクリダイカクゴマ	FEED BAR SLIDE BLOCK	
18	148834001	1	シメネジ3.57	SCREW, M3.57	
19	S08931001	1	スプレダタテジク	SPREADER VERTICAL SHAFT	
20	S08932000	1	スプレダタテジクメタル	SPREADER VERTICAL SHAFT BUSH	
21	081007670	1	リングPW7	O RING,PW7	
22	110197001	1	セットカラー	SET COLLAR	
23	014680422	2	アナトメネジ4.37クボミ	SET SCREW, SOCKET (CP) M4.37	
24	S08933001	1	スプレダホルダ	SPREADER HOLDER	
25	062681412	1	ナベコ437-40X14	SCREW, PAN M4.37-40X14	
26	S21962001	1	スプレダ	SPREADER	
27	062681012	1	ナベコ437-40X10	SCREW, PAN M4.37-40X10	

K1. 糸調子関係 / Thread tension / Fadernspannung / Tension du fil / Tensión del hilo

B276

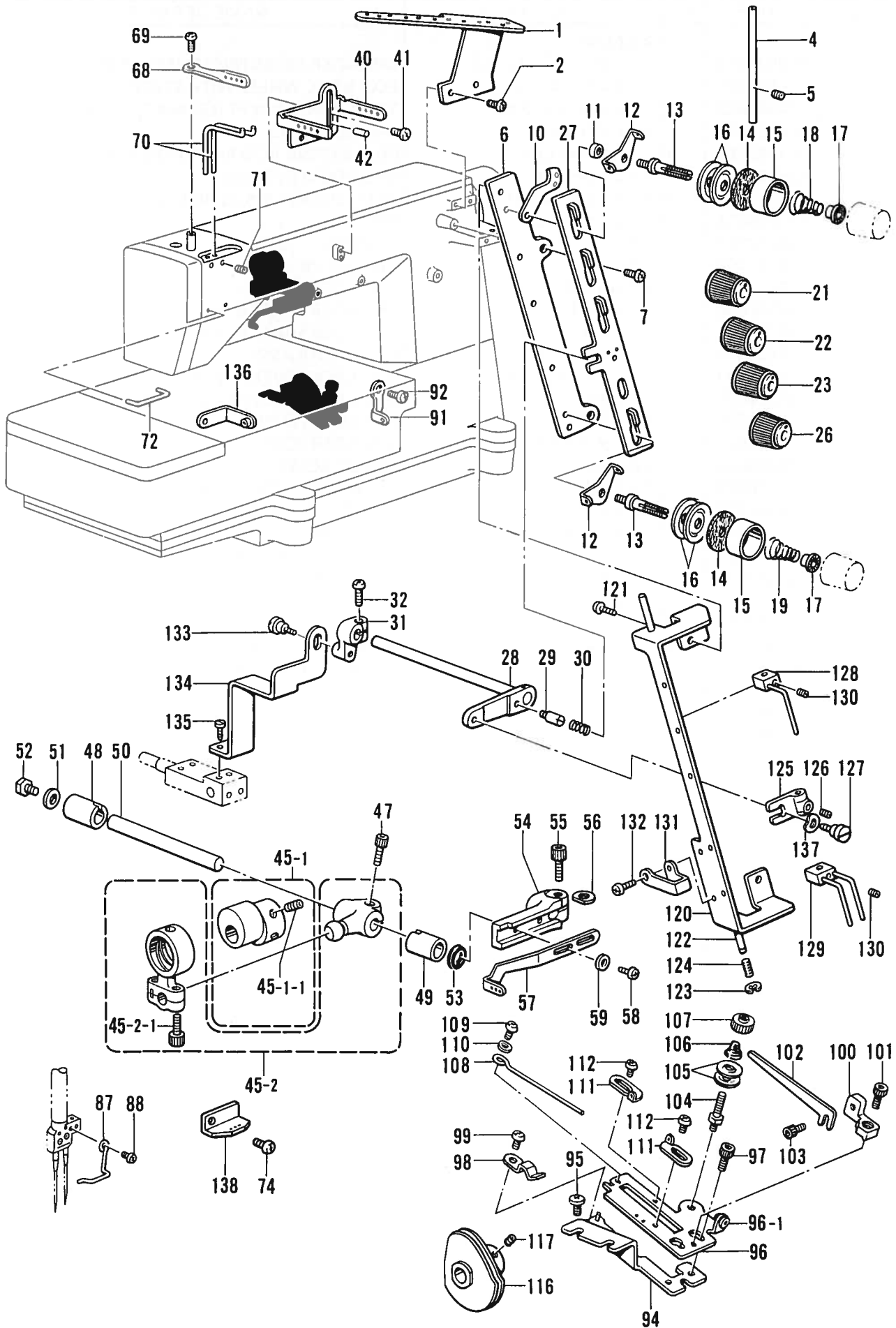

118-276-418

K1. 糸調子関係 / Thread tension / Faderspannung / Tension du fil / Tensión del hilo

REF.NO.	CODE	Q'TY	ヒンメイ	NAME OF PARTS	RM
			<B276>		
1	S08961101	1	シユイトアンナイ	MAIN THREAD GUIDE	
2	062680812	2	ナベコ437-40X8	SCREW, PAN M4.37-40X8	
4	150645009	1	イトアンナイパイプL	THREAD GUIDE PIPE (L)	
5	014680422	1	アナトメネジ4.37クボミ	SET SCREW, SOCKET (CP) M4.37	
6	S08962109	1	イトチヨウシダイ	TENSION BASE	
7	062681012	2	ナベコ437-40X10	SCREW, PAN M4.37-40X10	
10	S08963001	4	イトチヨウシダイイトアンナイ	TENSION BASE THREAD GUIDE	
11	S21878001	4	カンザ	SPACER	
12	110813001	4	ハリイトアンナイ	NEEDLE THREAD GUIDE	
13	159574101	4	イトチヨウシボウ	TENSION STUD	
14	110832009	4	イトチヨウシサラフェルト	TENSION DISC FELT	
15	144103009	4	イトチヨウシサラオサエ	TENSION DISC PRESSER	
16	145446001	8	イトチヨウシサラ	TENSION DISC	
17	S30564000	4	チヨウシバネウエザガネ	TENSION SPRING WASHER	
18	144104001	3	ハリイトチヨウシバネ	THREAD TENSION ADJUST SPRING	
19	144110001	1	シタルーバイトチヨウシバネ	THREAD TENSION ADJUST SPRING	
21	S30565003	1	イトチヨウシナツト (アカ)	TENSION NUT (RED)	
22	S30565004	1	イトチヨウシナツト (キイ)	TENSION NUT (YELLOW)	
23	S30565002	1	イトチヨウシナツト (ミドリ)	TENSION NUT (GREEN)	
26	S30565001	1	イトチヨウシナツト (ミズイロ)	TENSION NUT (LIGHT BLUE)	
27	S21879001	1	イトユルメイタ	TENSION RELEASE PLATE	
28	S21880001	1	イトユルメジク	TENSION RELEASE SHAFT	
29	S21881001	1	シメネジ4.76	SCREW, M4.76	
30	S21882001	1	イトユルメイタオシバネ	SPRING	
31	S21883001	1	イトユルメウデ	TENSION RELEASE ARM	
32	062681212	1	ナベコ437-40X12	SCREW, PAN M4.37-40X12	
40	S08969101	1	チユウカンイトアンナイ	THREAD GUIDE	
41	060680712	1	バインド437-40X7	SCREW, BIND M4.37-40X7	
42	143602001	1	ミゾツキピン	DOWEL PIN	
45	S08971201	1	ハリイトクリヘンシンリンクミ	NEEDLE THREAD TAKE-UP ECCENTRIC ASSY	
45-1	S10657001	1	イトクリヘンシンリンネジツキ	TAKE-UP ECCENTRIC WHEEL WITH SCREW	
45-1-1	014770622	2	アナトメネジ6.35クボミ	SET SCREW, SOCKET (CP) M6.35	
45-2	S08973101	1	ハリイトクリロッドクミ	THREAD TAKE-UP ECCENTRIC ROD ASSY	
45-2-1	018401422	2	アナボルト4X14	BOLT, SOCKET M4X14	
47	018771432	1	アナボルト635-40X14	BOLT, SOCKET M6.35-40X14	
48	155220000	1	ホジヨアツメタルR	AUTO PRESSER ARM BUSH (R)	
49	S08770000	1	ジクメタル	SHAFT BUSH	
50	S08976001	1	ハリイトクリジク	NEEDLE THREAD TAKE-UP SHAFT	
51	S00356001	1	ザガネ	WASHER	
52	S00383001	1	ボルト5.56X8	BOLT, M5.56X8	
53	155539000	1	ダストシール	DUST SEAL	
54	S08977001	1	ハリイトクリレバー	NEEDLE THREAD TAKE-UP LEVER	
55	018771432	1	アナボルト635-40X14	BOLT, SOCKET M6.35-40X14	
56	155162001	1	スパーサ	SPACER	
57	S08978001	1	ハリイトクリ	NEEDLE THREAD TAKE-UP	
58	062681012	2	ナベコ437-40X10	SCREW, PAN M4.37-40X10	
59	100645003	2	ザガネ	WASHER	
68	S08981001	1	ハリボウテンピン	NEEDLE BAR TAKE-UP	
69	062670612	1	ナベコ357-40X6	SCREW, PAN M3.57-40X6	
70	S08982001	2	ハリイトウケ	NEEDLE THREAD GUIDE	
71	014680422	2	アナトメネジ4.37クボミ	SET SCREW, SOCKET (CP) M4.37	
72	S08983001	1	アームハリイトウケ	ARM NEEDLE THREAD GUIDE	
74	062680812	1	ナベコ437-40X8	SCREW, PAN M4.37-40X8	
87	S08989001	1	ハリドメイトアンナイ	NEEDLE CLAMP THREAD GUIDE	
88	062630412	1	ナベコ238-56X4	SCREW, PAN M2.38-56X4	
91	S08970001	1	イトアンナイS	THREAD GUIDE (S)	
92	062680612	1	ナベコ4.37-40X6	SCREW, PAN M4.37-40X6	
94	S18530001	1	テンビンドダイDクミ	LOOPER THREAD TAKE-UP BASE (D) ASSY	
95	060680712	2	バインド437-40X7	SCREW, BIND M4.37-40X7	

K1. 糸調子関係 / Thread tension / Faderspannung / Tension du fil / Tensión del hilo

REF.NO.	CODE	Q'TY	ヒンメイ	NAME OF PARTS	RM
96	S18532001	1	テンビンダイUクミ	LOOPER THREAD TAKE-UP BASE (U) ASSY	
96-1	146924000	1	スレツドブツシユ	THREAD BUSH	
97	018680822	2	アナボルト4.37X8	BOLT, SOCKET M4.37X8	
98	S18534001	1	ドダイオサエバネ	SPRING	
99	062670512	1	ナベコ357-40X5	SCREW, PAN M3.57-40X5	
100	S18535001	1	イトオサエドダイ	THREAD PRESSER BASE	
101	154965001	1	アナボルト3.57X8	BOLT, SOCKET M3.57X8	
102	S08992001	1	テンビンイトオサエ	LOOPER TAKE-UP PRESSER	
103	154965001	1	アナボルト3.57X8	BOLT, SOCKET M3.57X8	
104	S08987001	1	イトチヨウシボウ	THREAD TENSION CONTROL STUD	
105	144504001	2	イトアンナイサラ	THREAD GUIDE DISC	
106	144505000	1	イトアンナイバネ	SPRING	
107	155510001	1	イトチヨウシナツト	TENSION NUT	
108	S08993101	1	テンビンイトウケ	TAKE-UP THREAD GUIDE	
109	062670512	1	ナベコ357-40X5	SCREW, PAN M3.57-40X5	
110	105161004	1	ザガネ	WASHER	
111	S08994001	2	テンビンイトアンナイ	THREAD GUIDE	
112	060660416	2	バインド318-40X4	SCREW, BIND M3.18-40X4	
116	S08995001	1	シタイトテンビンクミ	LOOPER THREAD TAKE-UP ASSY	
117	014680422	2	アナトメネジ4.37クボミ	SET SCREW, SOCKET (CP) M4.37	
120	S21884001	1	イトユルメアンナイ	TENSION RELEASE GUIDE	
121	060680512	2	バインド437-40X5	SCREW, BIND M4.37-40X5	
122	S21885001	1	イトトリジク	THREAD TAKE-UP SHAFT	
123	048030342	1	トメワE3	RETAINING RING, E3	
124	S21886001	1	カンシヨウバネ	SHOCK ABSORBING SPRING	
125	S21887001	1	イトトリレバー	THREAD TAKE-UP LEVER	
126	014680422	1	アナトメネジ4.37クボミ	SET SCREW, SOCKET (CP) M4.37	
127	144526001	1	ダンネジ4.37	STUD SCREW, M4.37	
128	S21888001	3	イトトリブロックSクミ	THREAD TAKE-UP BLOCK (S) ASSY	
129	S21891001	1	イトトリブロックWクミ	THREAD TAKE-UP BLOCK (W) ASSY	
130	014680422	4	アナトメネジ4.37クボミ	SET SCREW, SOCKET (CP) M4.37	
131	S21893001	1	イトユルメイトミチ	THREAD HANDING AREA	
132	062670512	1	ナベコ357-40X5	SCREW, PAN M3.57-40X5	
133	144526001	1	ダンネジ4.37	STUD SCREW, M4.37	
134	S21894001	1	イトユルメクドウイタ	TENSION RELEASE DRIVING PLATE	
135	100644005	2	シメネジ4.37	SCREW, M4.37	
136	146930001	1	イトアンナイクミ	THREAD GUIDE ASSY	
137	103810002	1	ナミガタバネザガネ	WAVE SPRING WASHER	
138	S28438001	1	アームイトアンナイD	ARM THREAD GUIDE (D)	

K2. 糸調子関係 / Thread tension / Fadenspannung / Tension du fil / Tensión del hilo

B277

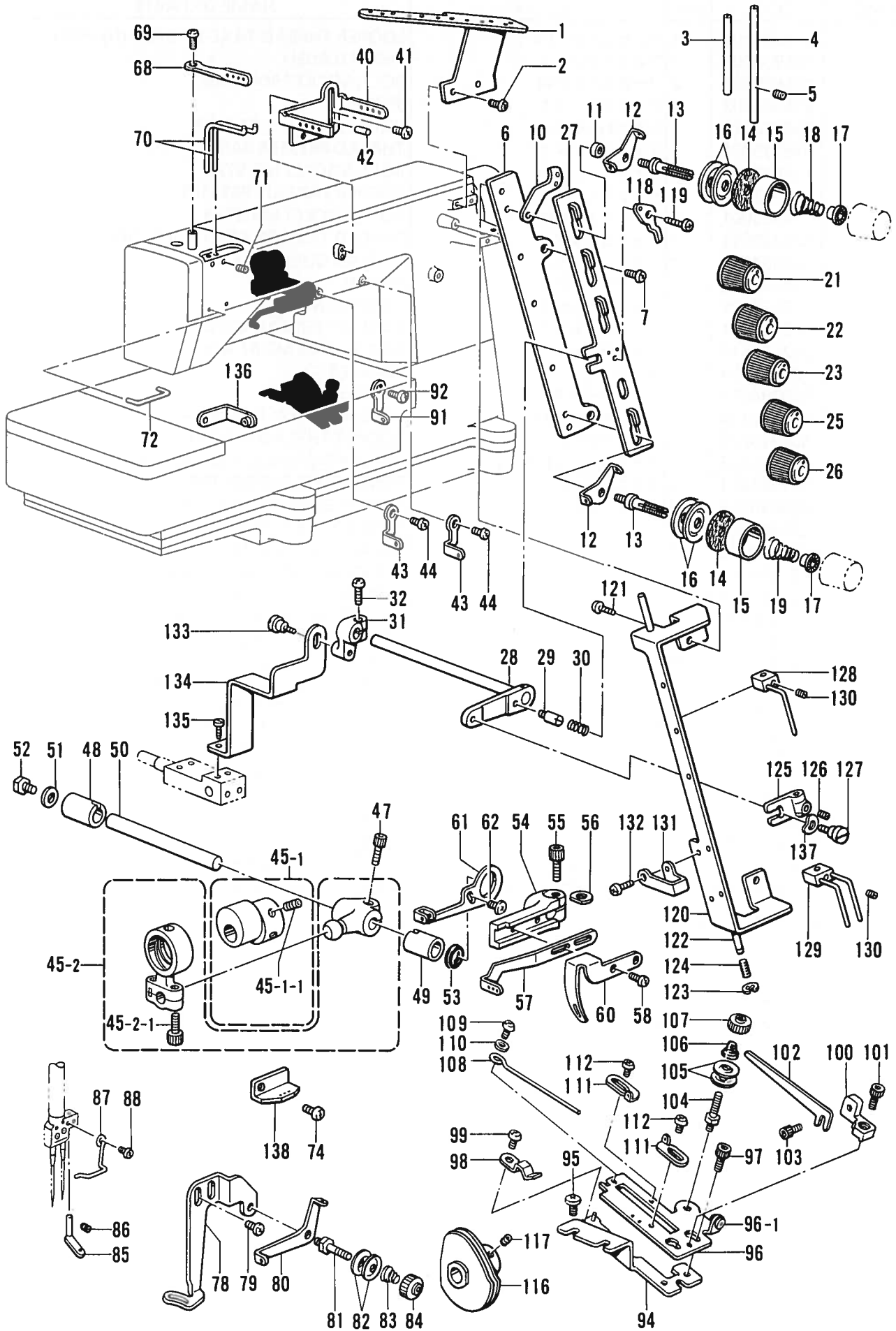

118-277-418

K2. 糸調子関係 / Thread tension / Faderspannung / Tension du fil / Tensión del hilo

REF.NO.	CODE	Q'TY	ヒンメイ	NAME OF PARTS	RM
			<B277>		
1	S08961101	1	シユイトアンナイ	MAIN THREAD GUIDE	
2	062680812	2	ナベコ437-40X8	SCREW, PAN M4.37-40X8	
3	150644009	1	イトアンナイハイブS	THREAD GUIDE PIPE (S)	
4	150645009	1	イトアンナイハイブL	THREAD GUIDE PIPE (L)	
5	014680422	1	アナトメネジ4.37クボミ	SET SCREW, SOCKET (CP) M4.37	
6	S08962109	1	イトチヨウシダイ	TENSION BASE	
7	062681012	2	ナベコ437-40X10	SCREW, PAN M4.37-40X10	
10	S08963001	5	イトチヨウシダイイトアンナイ	TENSION BASE THREAD GUIDE	
11	S21878001	5	カンザ	SPACER	
12	110813001	5	ハリイトアンナイ	NEEDLE THREAD GUIDE	
13	159574101	5	イトチヨウシボウ	TENSION STUD	
14	110832009	5	イトチヨウシサラフェルト	TENSION DISC FELT	
15	144103009	5	イトチヨウシサラオサエ	TENSION DISC PRESSER	
16	145446001	10	イトチヨウシサラ	TENSION DISC	
17	S30564000	5	チヨウシバネウエザガネ	TENSION SPRING WASHER	
18	144104001	3	ハリイトチヨウシバネ	THREAD TENSION ADJUST SPRING	
19	144110001	2	シタルーハイトチヨウシバネ	THREAD TENSION ADJUST SPRING	
21	S30565003	1	イトチヨウシナツト (アカ)	TENSION NUT (RED)	
22	S30565004	1	イトチヨウシナツト (キイ)	TENSION NUT (YELLOW)	
23	S30565002	1	イトチヨウシナツト (ミドリ)	TENSION NUT (GREEN)	
25	S30565003	1	イトチヨウシナツト (アカ)	TENSION NUT (RED)	
26	S30565001	1	イトチヨウシナツト (ミズイロ)	TENSION NUT (LIGHT BLUE)	
27	S21879001	1	イトユルメイタ	TENSION RELEASE PLATE	
28	S21880001	1	イトユルメジク	TENSION RELEASE SHAFT	
29	S21881001	1	シメネジ4.76	SCREW, M4.76	
30	S21882001	1	イトユルメイタオシバネ	SPRING	
31	S21883001	1	イトユルメウデ	TENSION RELEASE ARM	
32	062681212	1	ナベコ437-40X12	SCREW, PAN M4.37-40X12	
40	S08969101	1	チユウカンイトアンナイ	THREAD GUIDE	
41	060680712	1	バインド437-40X7	SCREW, BIND M4.37-40X7	
42	143602001	1	ミソツキピン	DOWEL PIN	
43	S08970001	2	イトアンナイS	THREAD GUIDE (S)	
44	062680612	2	ナベコ4.37-40X6	SCREW, PAN M4.37-40X6	
45	S08971201	1	ハリイトクリヘンシンリンクミ	NEEDLE THREAD TAKE-UP ECCENTRIC ASSY	
45-1	S10657001	1	イトクリヘンシンリンネジツキ	TAKE-UP ECCENTRIC WHEEL WITH SCREW	
45-1-1	014770622	2	アナトメネジ6.35クボミ	SET SCREW, SOCKET (CP) M6.35	
45-2	S08973101	1	ハリイトクリロッドクミ	THREAD TAKE-UP ECCENTRIC ROD ASSY	
45-2-1	018401422	2	アナボルト4X14	BOLT, SOCKET M4X14	
47	018771432	1	アナボルト635-40X14	BOLT, SOCKET M6.35-40X14	
48	155220000	1	ホジヨアツメタルR	AUTO PRESSER ARM BUSH (R)	
49	S08770000	1	ジクメタル	SHAFT BUSH	
50	S08976001	1	ハリイトクリジク	NEEDLE THREAD TAKE-UP SHAFT	
51	S00356001	1	ザガネ	WASHER	
52	S00383001	1	ボルト5.56X8	BOLT, M5.56X8	
53	155539000	1	ダストシール	DUST SEAL	
54	S08977001	1	ハリイトクリレバー	NEEDLE THREAD TAKE-UP LEVER	
55	018771432	1	アナボルト635-40X14	BOLT, SOCKET M6.35-40X14	
56	155162001	1	スペーサ	SPACER	
57	S08978001	1	ハリイトクリ	NEEDLE THREAD TAKE-UP	
58	062681012	2	ナベコ437-40X10	SCREW, PAN M4.37-40X10	
60	S08979001	1	カザリイトクリ	COVERING THREAD TAKE-UP	
61	S08980001	1	カザリイトアンナイR	COVERING THREAD GUIDE (R)	
62	060680712	1	バインド437-40X7	SCREW, BIND M4.37-40X7	
68	S08981001	1	ハリボウテンピン	NEEDLE BAR TAKE-UP	
69	062670612	1	ナベコ357-40X6	SCREW, PAN M3.57-40X6	
70	S08982001	2	ハリイトウケ	NEEDLE THREAD GUIDE	
71	014680422	2	アナトメネジ4.37クボミ	SET SCREW, SOCKET (CP) M4.37	
72	S08983001	1	アームハリイトウケ	ARM NEEDLE THREAD GUIDE	
74	062680812	1	ナベコ437-40X8	SCREW, PAN M4.37-40X8	
78	S08985001	1	カザリイトアンナイL	COVERING THREAD GUIDE (L)	

K2. 糸調子関係 / Thread tension / Fadernspannung / Tension du fil / Tensión del hilo

B277

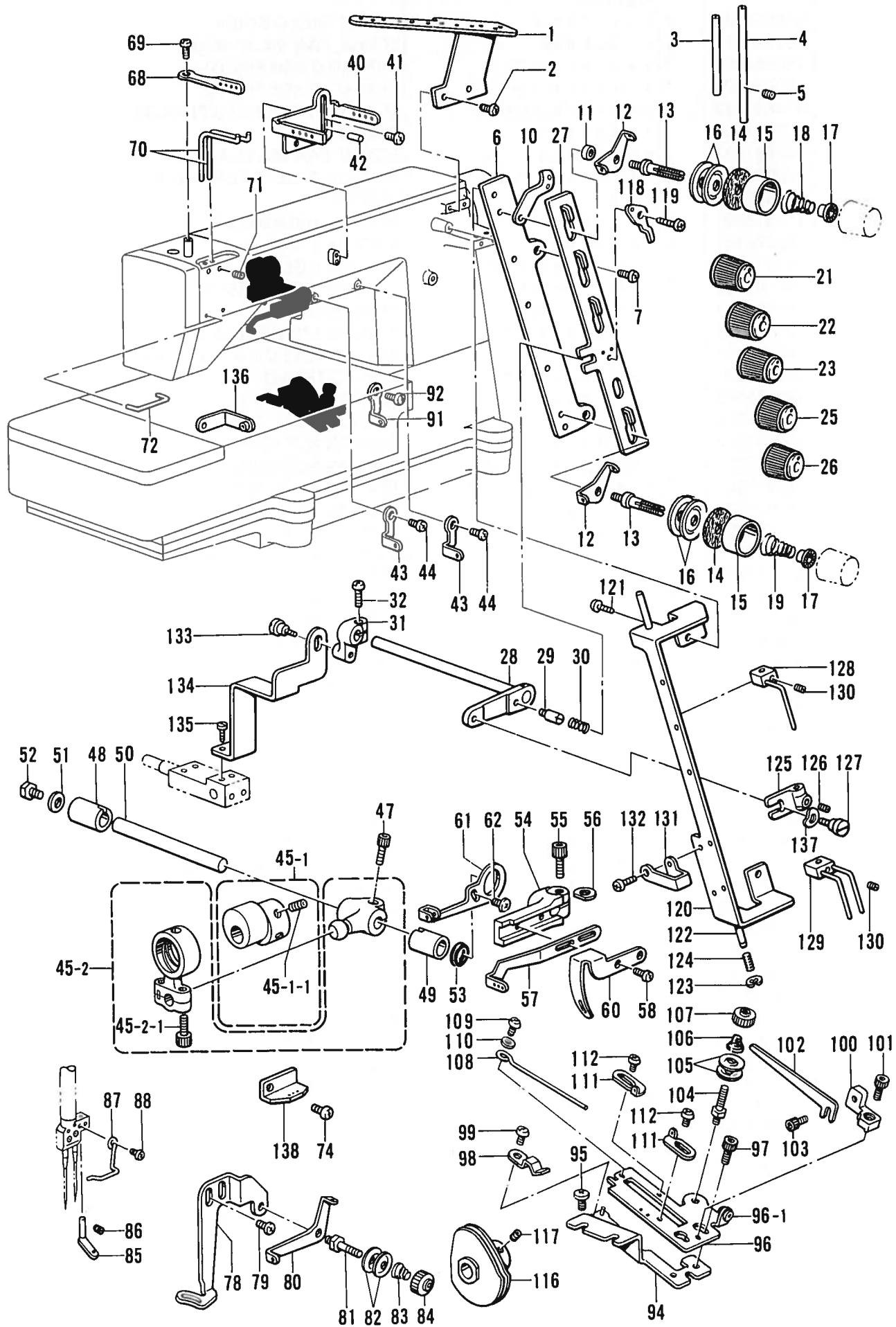

118-277-418

K2. 糸調子関係 / Thread tension / Faderspannung / Tension du fil / Tensión del hilo

REF.NO.	CODE	Q'TY	ヒンメイ	NAME OF PARTS	RM
79	060680712	2	バインド437-40X7	SCREW, BIND M4.37-40X7	
80	S08986001	1	カザリイトアンナイ	COVERING THREAD GUIDE	
81	S08987001	1	イトチヨウシボウ	THREAD TENSION CONTROL STUD	
82	144504001	2	イトアンナイサラ	TENSION DISC	
83	144505000	1	イトアンナイバネ	TENSION SPRING	
84	155510001	1	イトチヨウシナツト	TENSION NUT	
85	S08988001	1	ハリドメカザリイトアンナイ	NEEDLE CLAMP THREAD GUIDE	
86	146427001	1	アナトメネジ3.18クボミ	SET SCREW, SOCKET (CP) M3.18	
87	S08989001	1	ハリドメイトアンナイ	NEEDLE CLAMP THREAD GUIDE	
88	062630412	1	ナベコ238-56X4	SCREW, PAN M2.38-56X4	
91	S08970001	1	イトアンナイS	THREAD GUIDE (S)	
92	062680612	1	ナベコ4.37-40X6	SCREW, PAN M4.37-40X6	
94	S18530001	1	テンビンドダイDクミ	LOOPER THREAD TAKE-UP BASE (D) ASSY	
95	060680712	2	バインド437-40X7	SCREW, BIND M4.37-40X7	
96	S18532001	1	テンビンドダイUクミ	LOOPER THREAD TAKE-UP BASE (U) ASSY	
96-1	146924000	1	スレツドブツシュ	THREAD BUSH	
97	018680822	2	アナボルト4.37X8	BOLT, SOCKET M4.37X8	
98	S18534001	1	ドダイオサエバネ	SPRING	
99	062670512	1	ナベコ357-40X5	SCREW, PAN M3.57-40X5	
100	S18535001	1	イトオサエドダイ	THREAD PRESSER BASE	
101	154965001	1	アナボルト3.57X8	BOLT, SOCKET M3.57X8	
102	S08992001	1	テンビンイトオサエ	LOOPER TAKE-UP PRESSER	
103	154965001	1	アナボルト3.57X8	BOLT, SOCKET M3.57X8	
104	S08987001	1	イトチヨウシボウ	THREAD TENSION CONTROL STUD	
105	144504001	2	イトアンナイサラ	TENSION DISC	
106	144505000	1	イトアンナイバネ	TENSION SPRING	
107	155510001	1	イトチヨウシナツト	TENSION NUT	
108	S08993101	1	テンビンイトウケ	TAKE-UP THREAD GUIDE	
109	062670512	1	ナベコ357-40X5	SCREW, PAN M3.57-40X5	
110	105161004	1	ザガネ	WASHER	
111	S08994001	2	テンビンイトアンナイ	THREAD GUIDE	
112	060660416	2	バインド318-40X4	SCREW, BIND M3.18-40X4	
116	S08995001	1	シタイトテンピンクミ	LOOPER THREAD TAKE-UP ASSY	
117	014680422	2	アナトメネジ4.37クボミ	SET SCREW, SOCKET (CP) M4.37	
118	S21963001	1	イトユルメイタS	TENSION RELEASE PLATE (S)	
119	060680512	1	バインド437-40X5	SCREW, BIND M4.37-40X5	
120	S21884001	1	イトユルメアンナイ	TENSION RELEASE GUIDE	
121	060680512	2	バインド437-40X5	SCREW, BIND M4.37-40X5	
122	S21885001	1	イトトリジク	THREAD TAKE-UP SHAFT	
123	048030342	1	トメワE3	RETAINING RING, E3	
124	S21886001	1	カンシヨウバネ	SHOCK ABSORBING SPRING	
125	S21887001	1	イトトリレバー	THREAD TAKE-UP LEVER	
126	014680422	1	アナトメネジ4.37クボミ	SET SCREW, SOCKET (CP) M4.37	
127	144526001	1	ダンネジ4.37	STUD SCREW, M4.37	
128	S21888001	3	イトトリブロックSクミ	THREAD TAKE-UP BLOCK (S) ASSY	
129	S21891001	2	イトトリブロックWクミ	THREAD TAKE-UP BLOCK (W) ASSY	
130	014680422	5	アナトメネジ4.37クボミ	SET SCREW, SOCKET (CP) M4.37	
131	S21893001	2	イトユルメイトミチ	THREAD HANDING AREA	
132	062670512	2	ナベコ357-40X5	SCREW, PAN M3.57-40X5	
133	144526001	1	ダンネジ4.37	STUD SCREW, M4.37	
134	S21894001	1	イトユルメクドウイタ	TENSION RELEASE DRIVING PLATE	
135	100644005	2	シメネジ4.37	SCREW, M4.37	
136	146930001	1	イトアンナイクミ	THREAD GUIDE ASSY	
137	103810002	1	ナミガタバネザガネ	WAVE SPRING WASHER	
138	S28438001	1	アームイトアンナイD	ARM THREAD GUIDE (D)	

L. 糸払い関係 / Thread wiper mechanism / Fadenwischvorrichtung /
 Mécanisme de tire-fil / Mecanismo del limpiador de hilo

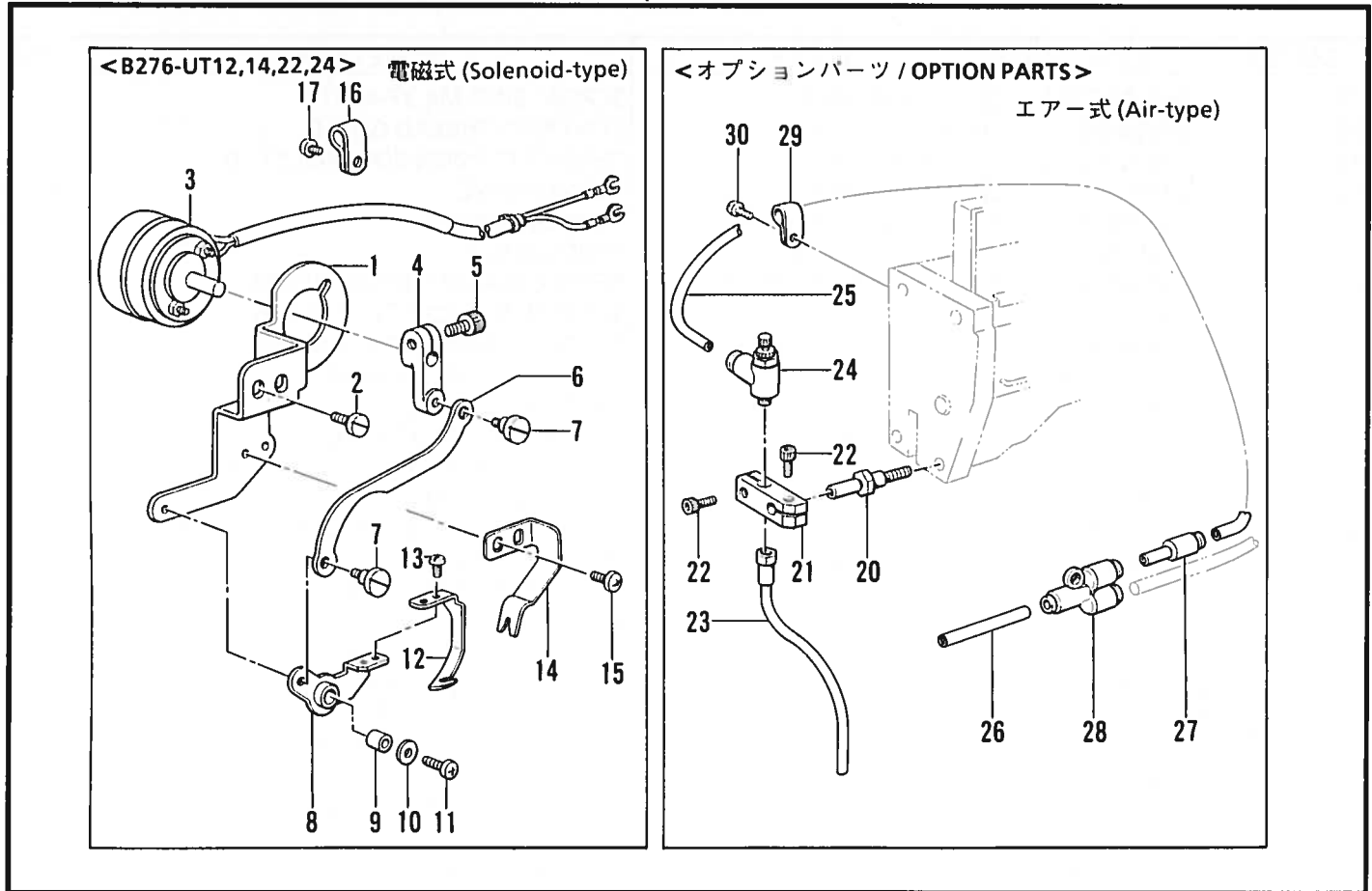

118-276-405

M. 針位置検出器関係 / Synchronizer / Synchronisator / Synchronisateur / Sincronizador

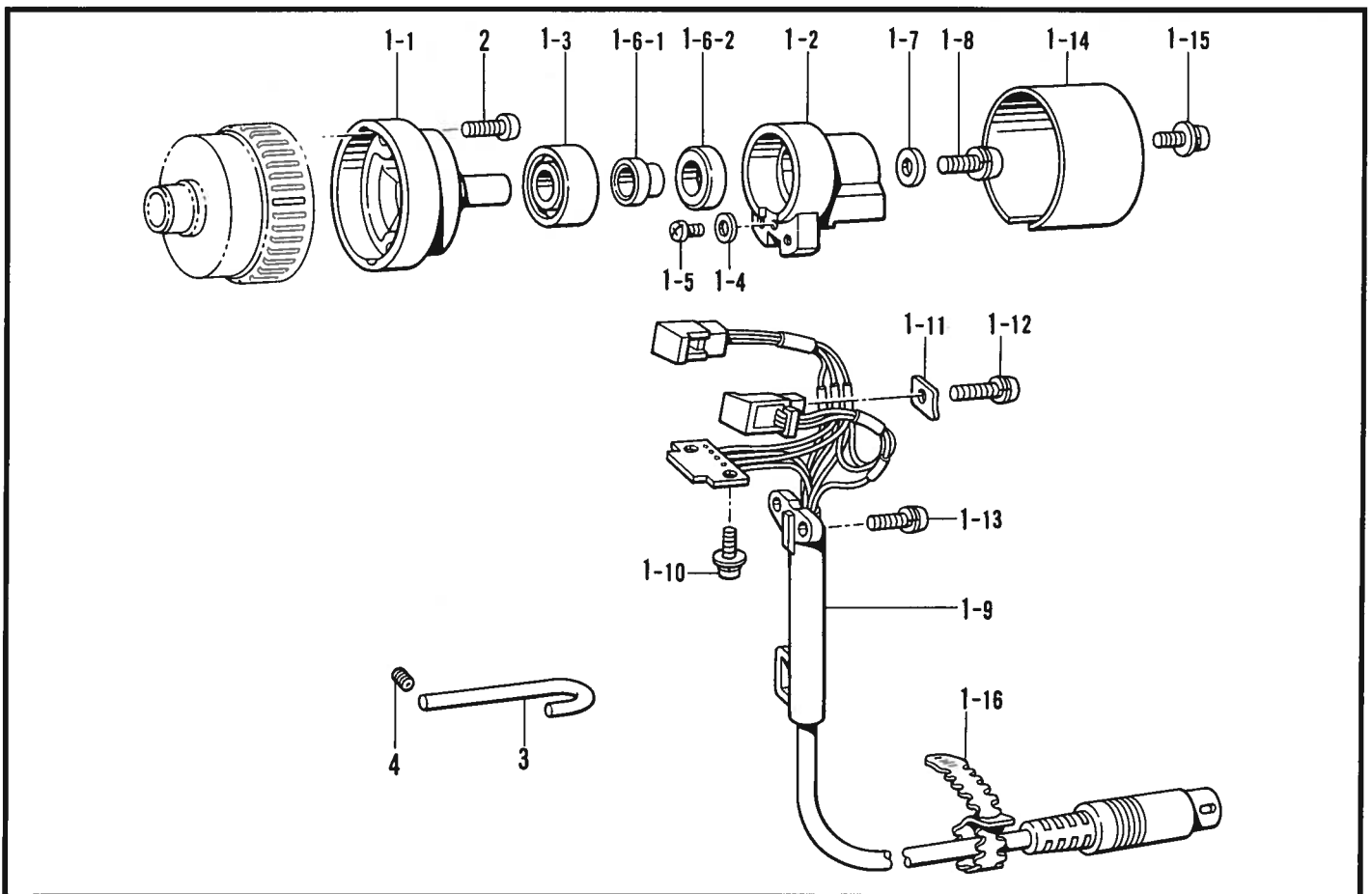

118-276,277-501

L. 糸払い関係 / Thread wiper mechanism / Fadenwischvorrichtung /
Mécanisme de tire-fil / Mecanismo del limpiador de hilo

REF.NO.	CODE	Q'TY	ヒンメイ	NAME OF PARTS	RM
<B276-UT12,14,22,24>					
1	S21867001	1	イトハライドダイ	THREAD WIPER BRACKET	
2	100644005	2	シメネジ4.37	SCREW, M4.37	
3	S21868101	1	イトハライソレノイドクミ	THREAD WIPER SOLENOID ASSY	
4	S21871101	1	イトハライレバー	THREAD WIPER LEVER	
5	018681022	1	アナボルト4.37X10	BOLT, SOCKET M4.37X10	
6	S21872101	1	イトハライロッド	THREAD WIPER ROD	
7	105237002	2	ダンネジ3.57	STUD SCREW, M3.57	
8	S21873001	1	イトハライクランク	THREAD WIPER CRANK	
9	S21874000	1	シテンジク	FULCRUM SHAFT	
10	S21875001	1	ザガネ	WASHER	
11	062670812	1	ナベコ3.57-40X8	SCREW, PAN M3.57-40X8	
12	S21876001	1	イトハライ	THREAD WIPER	
13	062630412	2	ナベコ238-56X4	SCREW, PAN M2.38-56X4	
14	S21877001	1	イトツカミバネ	THREAD CLAMP SPRING	
15	060670512	2	バインド357-40X5	SCREW, BIND M3.57-40X5	
16	149547000	5	コードオサエ4N	CORD HOLDER (4N)	
17	062680712	5	ナベコ437-40X7	SCREW, PAN M4.37-40X7	
<オプションパーツ/OPTION PARTS>					
20	S28897001	1	ワイバードダイジク	WIPER BRACKET SHAFT	
21	S28898001	1	ワイバードダイ	WIPER BRACKET	
22	018681032	2	アナボルト437-40X10	BOLT, SOCKET M4.37-40X10	
23	S28899001	1	ワイバークミ	WIPER ASSY	
24	S23660000	1	スピードコントローラ	SPEED CONTROLLER	
25	S14085011	1	エアチューブ(L=1410)	AIR TUBE (L=1410)	
26	S28744000	1	エアチューブ(L=40)	AIR TUBE (L=40)	
27	S28902000	1	レジューサ04-06	REDUCER 04-06	
28	S24021000	1	ユニオンワイ6	UNION (Y6)	
29	S10243000	5	ナイロンクランプNK-3N	CORD HOLDER NK-3N	
30	062680712	5	ナベコ437-40X7	SCREW, PAN M4.37-40X7	
参照番号 / Ref. No.		L-1~17 (電磁式 / Solenoid-type)		L-20~30 (エア式 / Air-type)	
糸払いセット / Thread wiper set		183821-101		S28896-001	

118-276-405

M. 針位置検出器関係 / Synchronizer / Synchronisator / Synchronisateur / Sincronizador

REF.NO.	CODE	Q'TY	ヒンメイ	NAME OF PARTS	RM
1	J00102001	1	シンクロナイザクミ#15G7	SYNCHRONIZER ASSY #15G7	
1-1	234141001	1	ジシャク.ジククミ#4-1	MAGNET STUD ASSY #4-1	
1-2	234143001	1	ケンシユツキホルダー#4	SYNCHRONIZER HOLDER #4	
1-3	076000600	1	タマジクウケ6000VV	BALL BEARING 6000VV	
1-4	025030335	1	ヒラザガネダイ3	WASHER, PLAIN L3	
1-5	215083001	1	+ナベセット3X6D	SCREW, PAN (S WASHER) M3X6D	
1-6	234144001	1	ジシャク18.7クミ	MAGNET 18.7 ASSY	
1-6-1	234145001	1	ジシャクトリツケダイ#2	MAGNET SET BRACKET #2	
1-6-2	219558000	1	ジシャク12X18.7X6	MAGNET (12X18.7X6)	
1-7	234146001	1	ワ2X5.1X12ST	WASHER (2X5.1X12ST)	
1-8	211528001	1	+ナベセットネジ5X12	SCREW, PAN (S WASHER) M5X12	
1-9	J00103001	1	ソシコードクミG15-2	ELEMENT CORD ASSY G15-2	
1-10	230100001	2	+ナベセット3X6DB	SCREW, PAN (S WASHER) M3X6DB	
1-11	234153001	2	オサエカナグ	PRESSER PLATE	
1-12	216870001	2	+ナベセット4X16D	SCREW, PAN (S WASHER) M4X16D	
1-13	215082001	2	+ナベセット4X12DA	SCREW, PAN (S WASHER) M4X12DA	
1-14	234154002	1	シンクロナイザカバー#5	SYNCHRONIZER COVER #5	
1-15	216410003	2	+ナベセット4X10DB	SCREW, PAN (S WASHER) M4X10DB	
1-16	226391001	1	コードバンド	CORD BAND	
2	062711212	2	ナベコ476-32X12	SCREW, PAN M4.76-32X12	
3	S21941001	1	シンクロナイザガイド	SYNCHRONIZER GUIDE	
4	014680622	1	アナトメネジ4.37クボミ	SET SCREW, SOCKET (CP) M4.37	

118-276,277-501

N1. 下飾り糸切り関係 / Lower thread trimmer mechanism / Unterefadensabschneider /
 Mécanisme de coupe-fils inférieur / Dispositivo de cortahilos inferior

B276-UT11,12,13,14
 B277-UT11,13,32,34

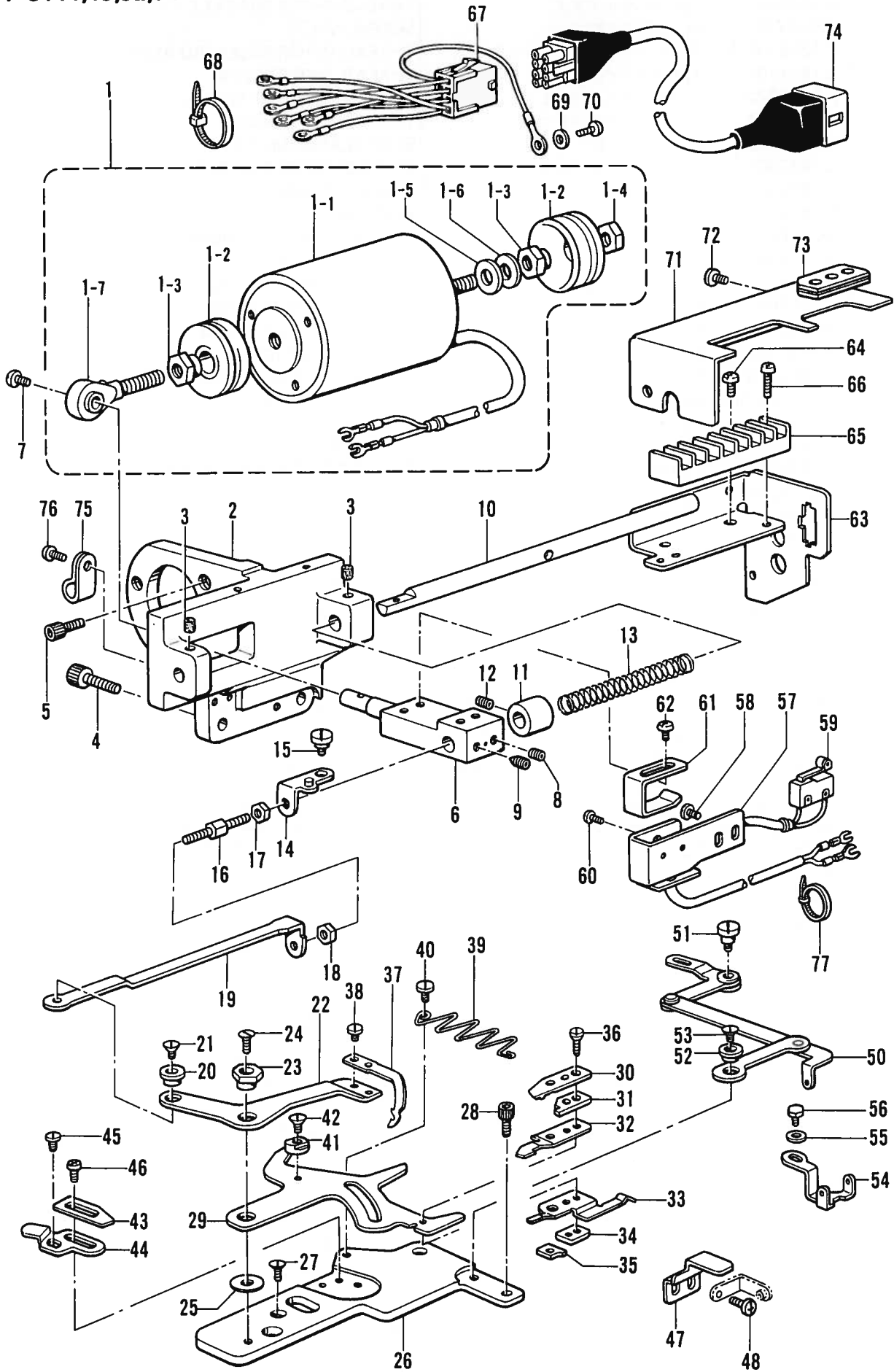

N1. 下飾り糸切り関係 / Lower thread trimmer mechanism / Unterefadensabschneider /
Mécanisme de coupe-fils inférieur / Dispositivo de cortahilos inferior

REF.NO.	CODE	Q'TY	ヒンメイ	NAME OF PARTS	RM
			<B276-UT11,12,13,14> <B277-UT11,13,32,34>		
1	S21895001	1	イトキリソレノイドクミ	THREAD TRIMMER SOLENOID ASSY	
1-1	S21896001	1	イトキリソレノイド	THREAD TRIMMER SOLENOID	
1-2	S21897000	2	ゴムブーツ	RUBBER BOOT	
1-3	S21898001	2	ナット8	NUT, M8	
1-4	021080302	1	ナット3シユ8	NUT, 3 M8	
1-5	S21899000	2	ストツバゴム	RUBBER STOPPER	
1-6	025080232	1	ヒラザガネチユウ8	WASHER, PLAIN M 8	
1-7	S21900001	1	ロツドエンド	ROD END	
2	S21901001	1	イトキリソレノイドドダイ	THREAD TRIMMER SOLENOID BRACKET	
3	S09043000	2	フェルト	FELT	
4	018062022	2	アナボルト6X20	BOLT, SOCKET M6X20	
5	018501222	3	アナボルト5X12	BOLT, SOCKET M5X12	
6	S21902001	1	イトキリクドウウデ	THREAD TRIMMER DRIVING ARM	
7	062680512	1	ナベコ437-40X5	SCREW, PAN M4.37-40X5	
8	014760622	1	アナトメネジ5.95	SET SCREW, SOCKET (CP) M5.95	
9	118853001	1	アナトメネジ5.95	SET SCREW, SOCKET M5.95	
10	S21903001	1	イトキリクドウジク	THREAD TRIMMER DRIVING SHAFT	
11	104521002	1	セツトカラー	SET COLLAR	
12	014770622	1	アナトメネジ6.35クボミ	SET SCREW, SOCKET (CP) M6.35	
13	S21904001	1	イトキリフツキバネ	CARRIAGE RETURN SPRING	
14	S21905001	1	クドウレンカンイタ	DRIVING CONNECTOR PLATE	
15	159908001	1	ダンネジ4.37	STUD SCREW, M4.37	
16	S21906001	1	クドウレンカンジク	DRIVING CONNECTING SHAFT	
17	S21907001	1	ナット5.56	NUT, M5.56	
18	110140001	1	ナット5.56	NUT, M5.56	
19	S21908001	1	クドウレンカン	DRIVING CONNECTOR	
20	S21909001	1	ツギテジク	JOINT SHAFT	
21	117143003	1	サラネジ4.37	SCREW, FLAT M4.37	
22	S21910001	1	シタメスレバー	LOWER KNIFE LEVER	
23	S21911001	1	シテンヘンシンジク	ECCENTRIC SHAFT	
24	107231002	1	サラネジ4.76	SCREW, FLAT M4.76	
25	S21912000	1	シテンザガネ	WASHER	
26	S21913001	1	シタイトキリドダイ	LOWER THREAD TRIMMER BRACKET	
27	105955002	2	シメネジ4.37	SCREW, M4.37	
28	018681022	1	アナボルト4.37X10	BOLT, SOCKET M4.37X10	
29	S21914001	1	ウワメスレバー	UPPER KNIFE LEVER	
30	S21915001	1	ウワメス	UPPER KNIFE	
31	S21916001	1	カンザ	SPACER	
32	S21917001	1	イトツカミバネ	THREAD CLAMP SPRING	
33	S21918001	1	イトツカミチヨウセツバネ	THREAD CLAMP ADJUST SPRING	
34	S21919001	1	アテイタ	CAUL SPACER	
35	S21920001	1	チヨウセツイタ	ADJUST PLATE	
36	S21921001	3	サラネジ2.38X8	SCREW, FLAT M2.38X8	
37	S21922001	1	シタメス	LOWER KNIFE	
38	106568003	2	シメネジ3.57	SCREW, M3.57	
39	S21923001	1	ウワメスレバーオシバネ	PUSH SPRING	
40	153222001	1	シメネジ4.37	SCREW, M4.37	
41	S21924001	1	シタメスストツバ	LOWER KNIFE STOPPER	
42	117143003	1	サラネジ4.37	SCREW, FLAT M4.37	
43	S21925001	1	ウワメスストツバA	UPPER KNIFE STOPPER (A)	
44	S21926001	1	ウワメスストツバB	UPPER KNIFE STOPPER (B)	
45	107419002	1	シメネジ4.37	SCREW, M4.37	
46	060680712	2	バインド437-40X7	SCREW, BIND M4.37-40X7	
47	S21927001	1	ウワメスレバーガイド	UPPER KNIFE LEVER GUIDE	
48	060670612	2	バインド357-40X6	SCREW, BIND M3.57-40X6	
50	S21928001	1	ルーバイトトリレバークミ	LOOPER THREAD TAKE-UP LEVER ASSY	
51	S16385001	1	ダンネジ4.37	STUD SCREW, M4.37	

N1. 下飾り糸切り関係 / Lower thread trimmer mechanism / Unterefadensabschneider / Mécanisme de coupe-fils inférieur / Dispositivo de cortahilos inferior

B276-UT11,12,13,14
B277-UT11,13,32,34

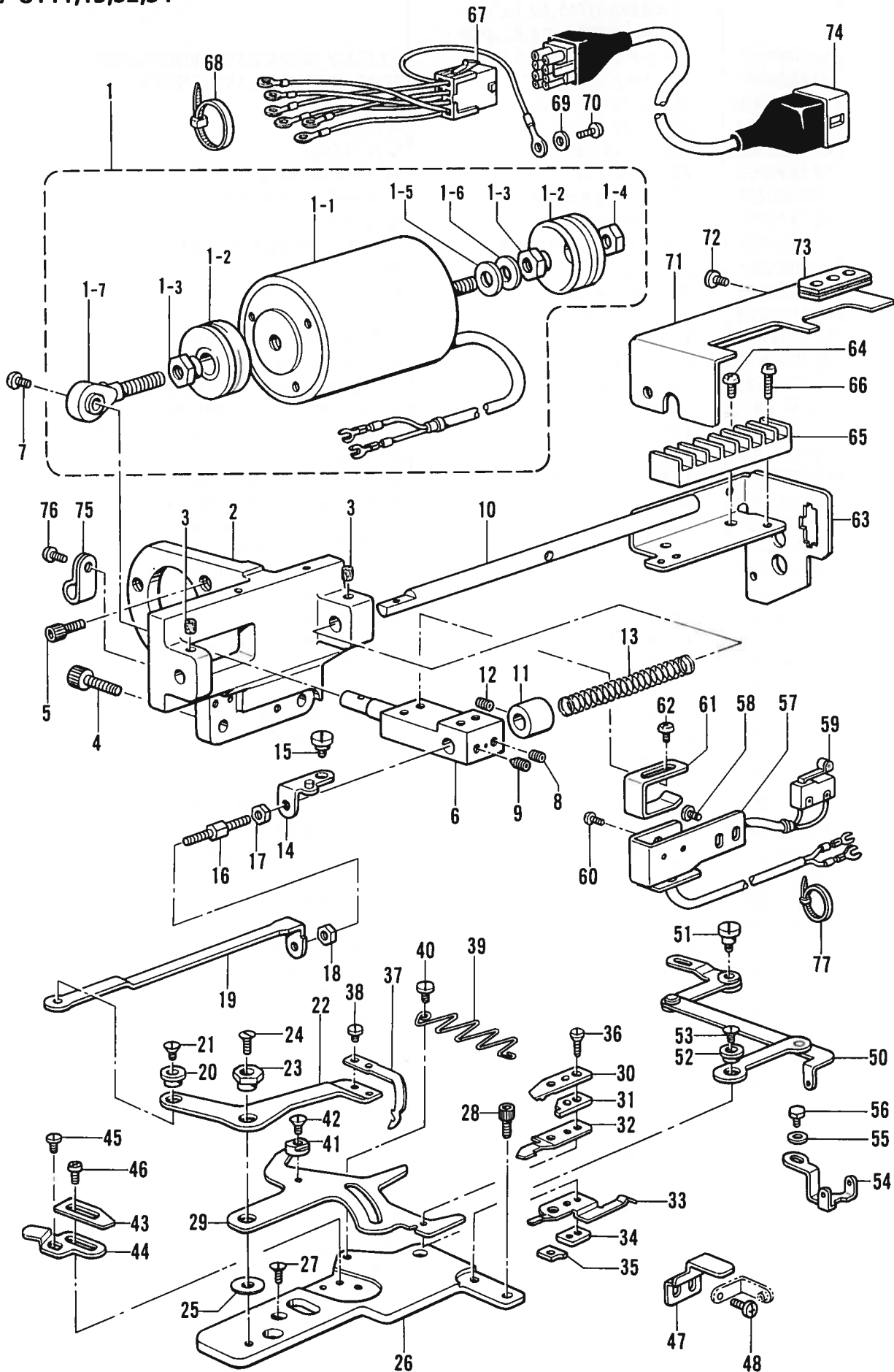

118-276,277-422

N1. 下飾り糸切り関係 / Lower thread trimmer mechanism / Unterefadensabschneider /
 Mécanisme de coupe-fils inférieur / Dispositivo de cortahilos inferior

REF.NO.	CODE	Q'TY	ヒンメイ	NAME OF PARTS	RM
52	S21909001	1	ツギテジク	JOINT SHAFT	
53	117143003	1	サラネジ4.37	SCREW, FLAT M4.37	
54	S21932001	1	ルーバイトアンナイ	LOOPER THREAD GUIDE	
55	025350236	1	ヒラザガネチユウ3.5	WASHER, PLAIN M 3.5	
56	144075001	1	ボルト3.57	BOLT, M3.57	
57	S21933001	1	スイッチダイ	SWITCH BASE	
58	060680712	2	バインド437-40X7	SCREW, BIND M4.37-40X7	
59	S21934001	1	スイッチクミ	SWITCH ASSY	
60	062020805	2	ナベコ2X8	SCREW, PAN M2X8	
61	S21935001	1	スイッチタイ	SWITCH PLATE	
62	060680712	2	バインド437-40X7	SCREW, BIND M4.37-40X7	
63	S28759001	1	コネクタターミナル	CONNECTOR TERMINAL	
64	060680712	4	バインド437-40X7	SCREW, BIND M4.37-40X7	
65	S21937001	1	タンシダイ	TERMINAL BLOCK	
66	062301616	2	ナベコM3X16	SCREW, PAN M3X16	
67	S21938001	1	コードクミ	CORD ASSY	
68	S04159000	1	バンド1M	BAND 1M	
69	S02745001	1	ザガネ	WASHER	
70	062680663	1	ナベコ437-40X6	SCREW, PAN M4.37-40X6	
71	S28760001	1	コネクタカバー	CONNECTOR COVER	
72	060680512	3	バインド437-40X5	SCREW, BIND M4.37-40X5	
73	233193001	1	テモトコードブツシング	CORD BUSH	
74	S21940101	1	ケーブルクミ	CABLE ASSY	
75	525907000	1	コードホルダ#9	CORD HOLDER (9N)	
76	062680712	1	ナベコ437-40X7	SCREW, PAN M4.37-40X7	
77	S04159000	1	バンド1M	BAND 1M	

N2. 下飾り糸切り関係 / Lower thread trimmer mechanism / Unterefadensabschneider /
 Mécanisme de coupe-fils inférieur / Dispositivo de cortahilos inferior

B276-UT21,22,23,24
 B277-UT21,23,42,44

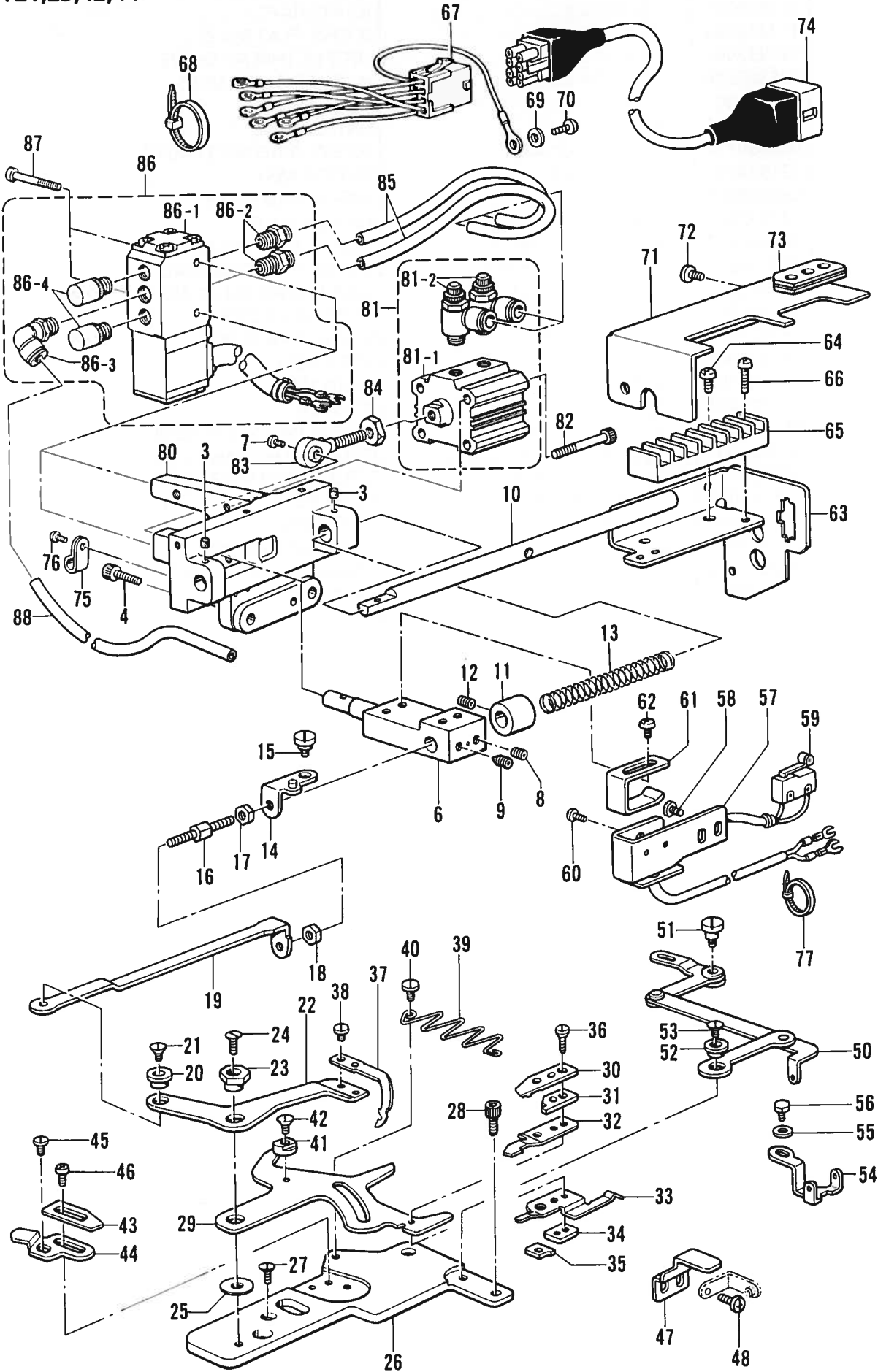

N2. 下飾り糸切り関係 / Lower thread trimmer mechanism / Unterefadensabschneider /
 Mécanisme de coupe-fils inférieur / Dispositivo de cortahilos inferior

REF.NO.	CODE	Q'TY	ヒンメイ	NAME OF PARTS	RM
			<B276-UT21,22,23,24> <B277-UT21,23,42,44>		
3	S09043000	2	フェルト	FELT	
4	018062022	2	アナボルト6X20	BOLT, SOCKET M6X20	
6	S21902001	1	イトキリクドウウデ	THREAD TRIMMER DRIVING ARM	
7	062680512	1	ナベコ437-40X5	SCREW, PAN M4.37-40X5	
8	014760622	1	アナトメネジ5.95	SET SCREW, SOCKET (CP) M5.95	
9	118853001	1	アナトメネジ5.95	SET SCREW, SOCKET M5.95	
10	S21903001	1	イトキリクドウジク	THREAD TRIMMER DRIVING SHAFT	
11	104521002	1	セットカラー	SET COLLAR	
12	014770622	1	アナトメネジ6.35クボミ	SET SCREW, SOCKET (CP) M6.35	
13	S21904001	1	イトキリフツキバネ	CARRIAGE RETURN SPRING	
14	S21905001	1	クドウレンカンイタ	DRIVING CONNECTOR PLATE	
15	159908001	1	ダンネジ4.37	STUD SCREW 4.37	
16	S21906001	1	クドウレンカンジク	DRIVING CONNECTING SHAFT	
17	S21907001	1	ナット5.56	NUT, M5.56	
18	110140001	1	ナット5.56	NUT, M5.56	
19	S21908001	1	クドウレンカン	DRIVING CONNECTOR	
20	S21909001	1	ツギテジク	JOINT SHAFT	
21	117143003	1	サラネジ4.37	SCREW, FLAT M4.37	
22	S21910001	1	シタメスレバー	LOWER KNIFE LEVER	
23	S21911001	1	シテンヘンシンジク	ECCENTRIC SHAFT	
24	107231002	1	サラネジ4.76	SCREW, FLAT M4.76	
25	S21912000	1	シテンザガネ	WASHER	
26	S21913001	1	シタイトキリドダイ	LOWER THREAD TRIMMER BRACKET	
27	105955002	2	シメネジ4.37	SCREW, M4.37	
28	018681022	1	アナボルト4.37X10	BOLT, SOCKET M4.37X10	
29	S21914001	1	ウワメスレバー	UPPER KNIFE LEVER	
30	S21915001	1	ウワメス	UPPER KNIFE	
31	S21916001	1	カンザ	SPACER	
32	S21917001	1	イトツカミバネ	THREAD CLAMP SPRING	
33	S21918001	1	イトツカミチヨウセツバネ	THREAD CLAMP ADJUST SPRING	
34	S21919001	1	アテイタ	CAUL SPACER	
35	S21920001	1	チヨウセツイタ	ADJUST PLATE	
36	S21921001	3	サラネジ2.38X8	SCREW, FLAT M2.38X8	
37	S21922001	1	シタメス	LOWER KNIFE	
38	106568003	2	シメネジ3.57	SCREW, M3.57	
39	S21923001	1	ウワメスレバーオシバネ	PUSH SPRING	
40	153222001	1	シメネジ4.37	SCREW, M4.37	
41	S21924001	1	シタメスストツバ	LOWER KNIFE STOPPER	
42	117143003	1	サラネジ4.37	SCREW, FLAT M4.37	
43	S21925001	1	ウワメスストツバA	UPPER KNIFE STOPPER (A)	
44	S21926001	1	ウワメスストツバB	UPPER KNIFE STOPPER (B)	
45	107419002	1	シメネジ4.37	SCREW, M4.37	
46	060680712	2	バインド437-40X7	SCREW, BIND M4.37-40X7	
47	S21927001	1	ウワメスレバーガイド	UPPER KNIFE LEVER GUIDE	
48	060670612	2	バインド357-40X6	SCREW, BIND M3.57-40X6	
50	S21928001	1	ルーバイトトリレバークミ	LOOPER THREAD TAKE-UP LEVER ASSY	
51	S16385001	1	ダンネジ4.37	STUD SCREW, M4.37	
52	S21909001	1	ツギテジク	JOINT SHAFT	
53	117143003	1	サラネジ4.37	SCREW, FLAT M4.37	
54	S21932001	1	ルーバイトアンナイ	LOOPER THREAD GUIDE	
55	025350236	1	ヒラザガネチユウ3.5	WASHER, PLAIN M 3.5	
56	144075001	1	ボルト3.57	BOLT, M3.57	
57	S21933001	1	スイッチダイ	SWITCH BASE	
58	060680712	2	バインド437-40X7	SCREW, BIND M4.37-40X7	
59	S21934001	1	スイッチクミ	SWITCH ASSY	
60	062020805	2	ナベコ2X8	SCREW, PAN M2X8	
61	S21935001	1	スイッチイタ	SWITCH PLATE	

N2. 下飾り糸切り関係 / Lower thread trimmer mechanism / Unterefadenabschneider /
 Mécanisme de coupe-fils inférieur / Dispositivo de cortahilos inferior

B276-UT21,22,23,24
 B277-UT21,23,42,44

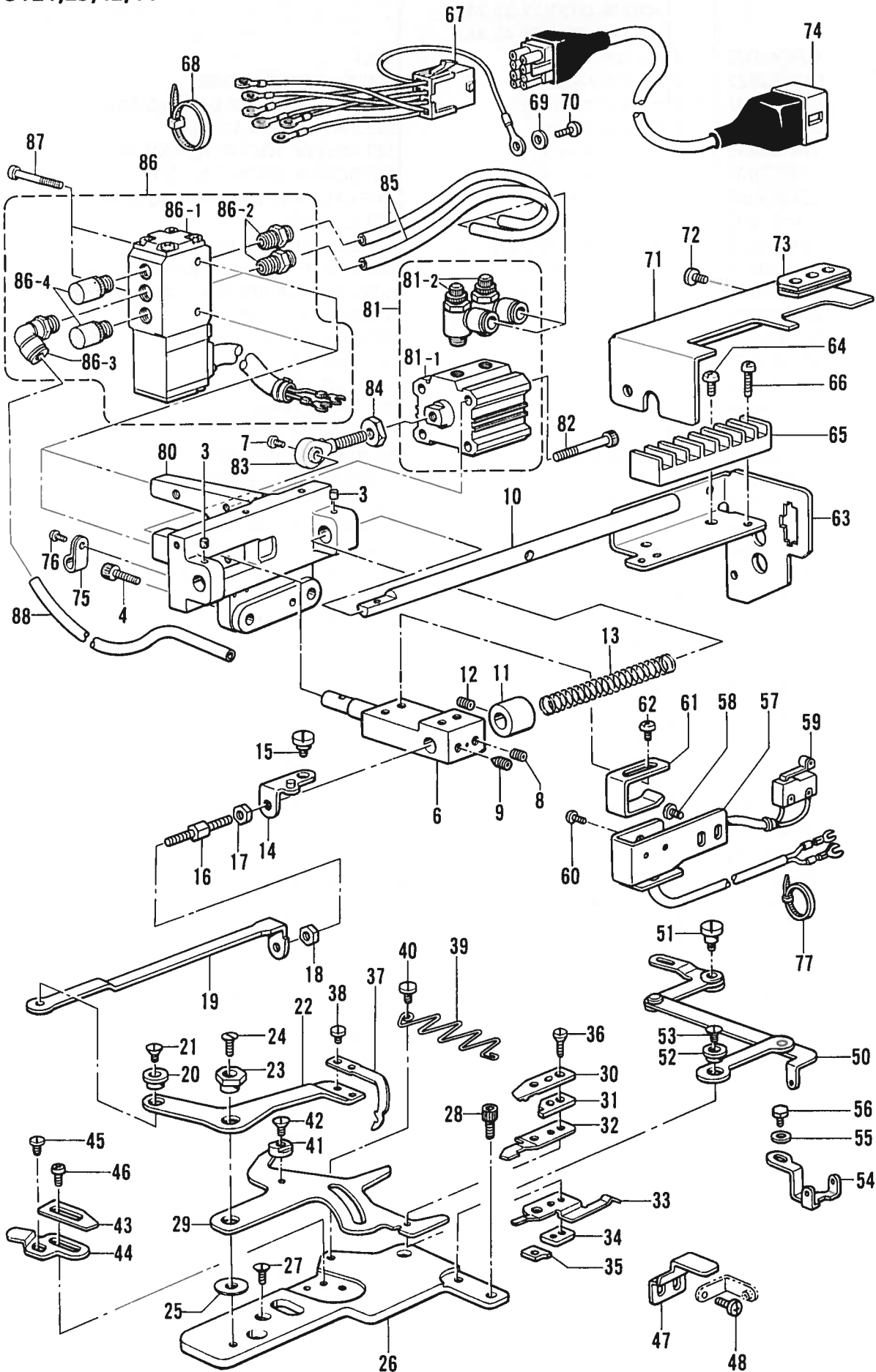

N2. 下飾り糸切り関係 / Lower thread trimmer mechanism / Unterefadenabschneider /
Mécanisme de coupe-fils inférieur / Dispositivo de cortahilos inferior

REF.NO.	CODE	Q'TY	ヒンメイ	NAME OF PARTS	RM
62	060680712	2	バインド437-40X7	SCREW, BIND M4.37-40X7	
63	S28759001	1	コネクタターミナル	CONNECTOR TERMINAL	
64	060680712	4	バインド437-40X7	SCREW, BIND M4.37-40X7	
65	S21937001	1	タンシダイ	TERMINAL BLOCK	
66	062301616	2	ナベコM3X16	SCREW, PAN M3X16	
67	S21938001	1	コードクミ	CORD ASSY	
68	S04159000	1	バンド1M	BAND 1M	
69	S02745001	1	ザガネ	WASHER	
70	062680663	1	ナベコ437-40X6	SCREW, PAN M4.37-40X6	
71	S28760001	1	コネクタカバー	CONNECTOR COVER	
72	060680512	3	バインド437-40X5	SCREW, BIND M4.37-40X5	
73	233193001	1	テモトコードブツシング	CORD BUSH	
74	S21940101	1	ケーブルクミ	CABLE ASSY	
75	S25907000	1	コードホルダ#9	CORD HOLDER (9N)	
76	062680712	1	ナベコ437-40X7	SCREW, PAN M4.37-40X7	
77	S04159000	1	バンド1M	BAND 1M	
80	S28678001	1	イトクリシリンダードダイ	THREAD TRIMMER CYLINDER BRACKET	
81	S28670000	1	エアシリンダクミ	AIR CYLINDER ASSY	
81-1	S28671000	1	エアシリンダ	AIR CYLINDER	
81-2	S28599000	2	スピードコントローラ	SPEED CONTROLLER	
82	415006002	4	アナボルト5X40	BOLT, SOCKET M5X40	
83	S21900001	1	ロッドエンド	ROD END	
84	021080302	1	ナツト3シユ8	NUT, 3 M8	
85	S28674000	2	エアチューブ (L = 200)	AIR TUBE (L = 200)	
86	S28675000	1	ソレノイドバルブクミ	SOLENOID VALVE ASSY	
86-1	S28676000	1	ソレノイドバルブ	SOLENOID VALVE	
86-2	S01522000	2	ハーフユニオン	HALF UNION	
86-3	S01542000	1	エルボユニオン61	ELBOW UNION 61	
86-4	159874000	2	サイレンサー	SILENCER	
87	062303012	2	ナベコM3X30	SCREW, PAN M3X30	
88	S28677000	1	エアチューブ (L = 1000)	AIR TUBE (L = 1000)	

P. 上飾り糸切り関係 / Upper thread trimmer mechanism / Oberfadenabschneider /
 Mécanisme de coupe-fils supérieur / Dispositivo de cortahilos superior

<B277-UT32,34,42,44>

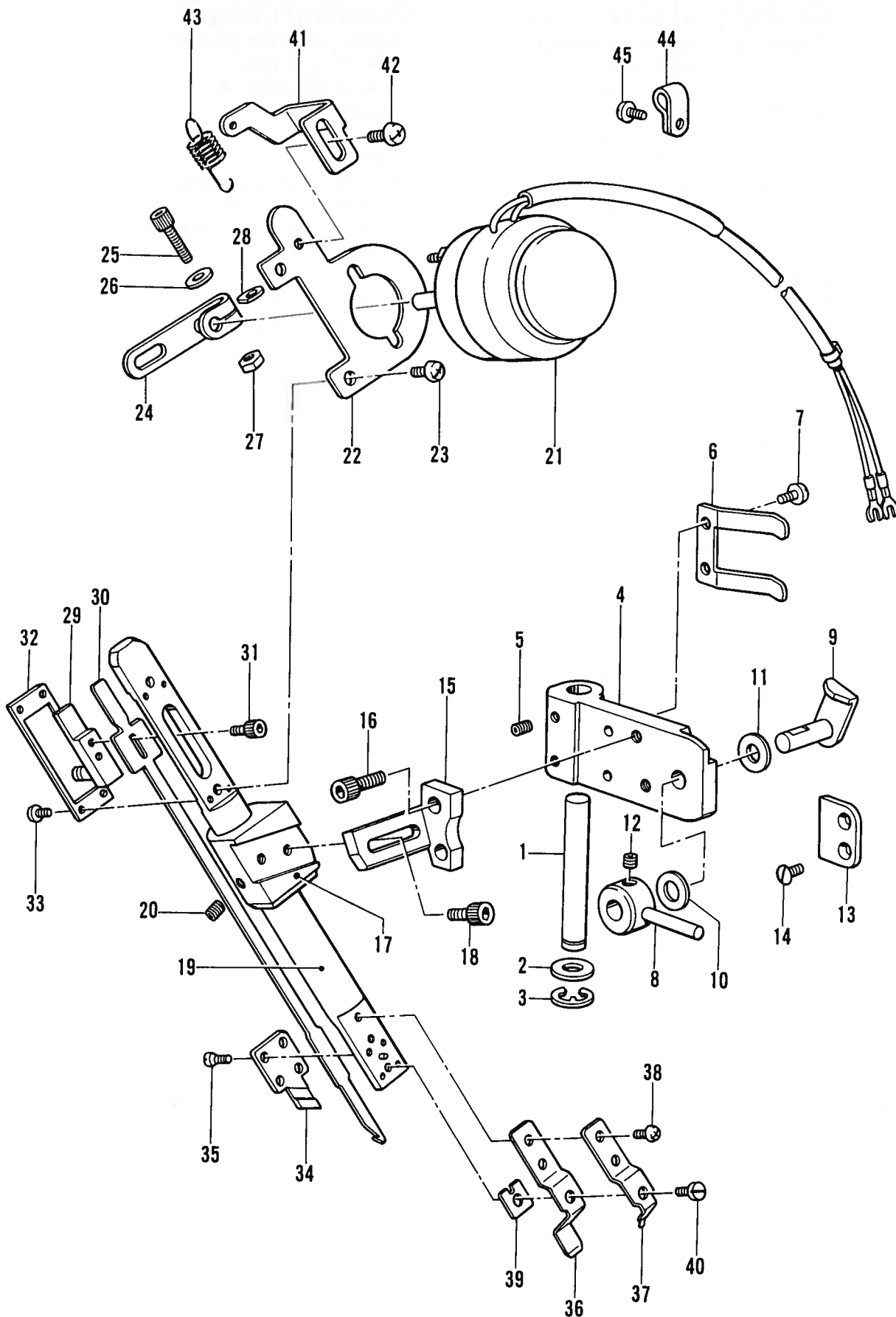

P. 上飾り糸切り関係 / Upper thread trimmer mechanism / Oberfadenabschneider / Mécanisme de coupe-fils supérieur / Dispositivo de cortahilos superior

REF.NO.	CODE	Q'TY	ヒンメイ	NAME OF PARTS	RM
			<B277-UT32,34,42,44>		
1	S21964001	1	ドダイササエジク	SUPPORT SHAFT	
2	S07350001	1	ザガネ	WASHER	
3	048050342	1	トメワE5	RETAINING RING, E5	
4	S21965001	1	イトキリドダイ	THREAD TRIMMER BRACKET	
5	014680422	2	アナトメネジ4.37クボミ	SET SCREW, SOCKET (CP) M4.37	
6	S21966001	1	イトキリドダイバネ	SPRING	
7	062680512	2	ナベコ437-40X5	SCREW, PAN M4.37-40X5	
8	S21967001	1	イトキリドダイレバー	THREAD TRIMMER BRACKET LEVER	
9	S21968001	1	ドダイレバージク	LEVER SHAFT	
10	118735002	1	ザガネ	WASHER	
11	109763002	1	ザガネ	WASHER	
12	014680422	2	アナトメネジ4.37クボミ	SET SCREW, SOCKET (CP) M4.37	
13	S21969001	1	イトキリドダイストツバ	STOPPER	
14	S01696001	2	サラネジ3.57X6	SCREW, FLAT M3.57X6	
15	S21970001	1	イトキリトリツケタイ	SET PLATE	
16	018501022	2	アナボルト5X10	BOLT, SOCKET M5X10	
17	S21971001	1	メスガイドシジダイ	KNIFE GUIDE BASE	
18	018680822	2	アナボルト4.37X8	BOLT, SOCKET M4.37X8	
19	S21972001	1	メスガイドクミ	KNIFE GUIDE ASSY	
20	014680422	2	アナトメネジ4.37クボミ	SET SCREW, SOCKET (CP) M4.37	
21	S21974001	1	イトキリソレノイドクミ	THREAD TRIMMER SORENOID ASSY	
22	S21976001	1	ソレノイドダイ	SORENOID BRACKET	
23	062680612	2	ナベコ4.37-40X6	SCREW, PAN M4.37-40X6	
24	S21977001	1	イトキリウドウウデ	THREAD TRIMMER DRIVING ARM	
25	018401422	1	アナボルト4X14	BOLT, SOCKET M4X14	
26	100645003	1	ザガネ	WASHER	
27	021400102	1	ナツト1シユ4	NUT, 1 M4	
28	S21978000	1	カンザ	SPACER	
29	S21979001	1	メスクドウコマ	KNIFE DRIVING BLOCK	
30	S21980001	1	イドウメス	MOVABLE KNIFE	
31	018300622	2	アナボルト3X6	BOLT, SOCKET M3X6	
32	S21981001	1	ガイドイタ	GUIDE PLATE	
33	062630412	4	ナベコ238-56X4	SCREW, PAN M2.38-56X4	
34	S21982101	1	コテイメス	FIXED KNIFE	
35	S21983001	4	サラネジ2.38X5.5	SCREW, FLAT M2.38X5.5	
36	S21984001	1	イトツカミバネ	THREAD CLAMP SPRING	
37	S21985001	1	イトツカミチヨウセツバネ	THREAD CLAMP ADJUST SPRING	
38	062660512	2	ナベコネジ318-40X5	SCREW, PAN M3.18-40X5	
39	S21986001	1	スパーサ	SPACER	
40	102836004	1	シメネジ3.18	SCREW, M3.18	
41	S21987001	1	バネカケ	SPRING HOOK	
42	060680512	1	バインド437-40X5	SCREW, BIND M4.37-40X5	
43	S21988001	1	モドシバネ	RETURN SPRING	
44	149547000	5	コードオサエ4N	CORD HOLDER (4N)	
45	062680712	5	ナベコ437-40X7	SCREW, PAN M4.37-40X7	

Q. 電磁押工上げ関係 / Presser foot lifting solenoid set /
 Solenoidsatz für die anhebung des stoffdrückerfußes /
 Conjunto aéreo del levantador del pie / Conjunto solenoide del levantador

B276-UT13,UT14
 B277-UT13,UT34

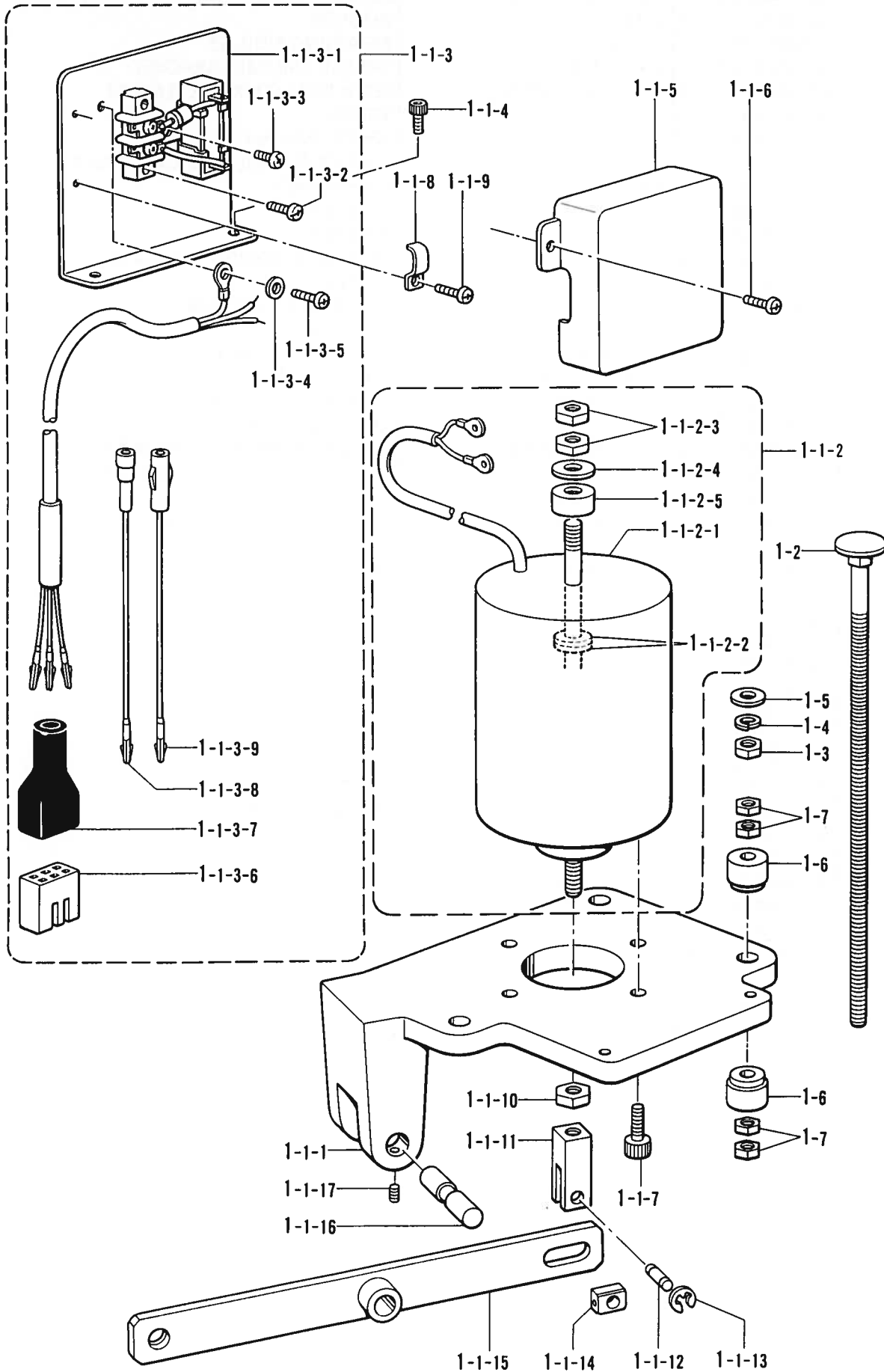

Q. 電磁押工上ゲ関係 / Presser foot lifting solenoid set /
 Solenoidsatz für die anhebung des stoffdrückerfußes /
 Conjunto aéreo del levantador del pie / Conjunto solenoide del levantador

REF.NO.	CODE	Q'TY	ヒンメイ	NAME OF PARTS	RM
			<B276-UT13,UT14> <B277-UT13,UT34>		
1	183796201	1	デンジオサエアゲセットB	SOLENOID PRESSER FOOT LIFTING SET (B)	
1-1	S21946101	1	デンジオサエアゲクミ	SOLENOID PRESSER FOOT LIFTING ASSY	
1-1-1	S21947001	1	ソレノイドダイ	SOLENOID BRACKET	
1-1-2	S21948101	1	オサエアゲソレノイドクミ	PRESSER FOOT LIFTING SOLENOID ASSY	
1-1-2-1	S21949101	1	オサエアゲソレノイド	PRESSER FOOT LIFTING SOLENOID	
1-1-2-2	S21899000	2	ストツハゴム	RUBBER STOPPER	
1-1-2-3	021080302	2	ナツト3シユ8	NUT, 3 M8	
1-1-2-4	025080232	1	ヒラザガネチユウ8	WASHER, PLAIN M 8	
1-1-2-5	S28821000	1	カンシヨウゴム	CUSHION RUBBER	
1-1-3	S21950009	1	タンシダイベースクミ	TERMINAL BLOCK BASE ASSY	
1-1-3-1	S21951001	1	タンシダイベース	TERMINAL BLOCK BASE	
1-1-3-2	062671012	2	ナベコ357-40X10	SCREW, PAN M3.57-40X10	
1-1-3-3	062670612	1	ナベコ357-40X6	SCREW, PAN M3.57-40X6	
1-1-3-4	S02745001	1	ザガネ	WASHER	
1-1-3-5	062680663	1	ナベコ437-40X6	SCREW, PAN M4.37-40X6	
1-1-3-6	143522000	1	ナイロンコネクター	NYLON CONNECTOR	
1-1-3-7	220077001	1	プラグカバー#14	PLUG COVER (#14)	
1-1-3-8	S05981000	1	Bコード100クミ2	B-CORD 100 ASSY 2	
1-1-3-9	S05982000	1	Wコード100クミ	W-CORD 100 ASSY	
1-1-4	018400832	2	アナボルト4X8	BOLT, SOCKET M4X8	
1-1-5	S02592009	1	タンシダイカバー	TERMINAL BLOCK COVER	
1-1-6	062670612	2	ナベコ357-40X6	SCREW, PAN M3.57-40X6	
1-1-7	018061631	4	アナボルト6X16	BOLT, SOCKET M6X16	
1-1-8	142268001	1	コードオサエL	CORD HOLDER (L)	
1-1-9	062670612	1	ナベコ357-40X6	SCREW, PAN M3.57-40X6	
1-1-10	021080302	1	ナツト3シユ8	NUT, 3 M8	
1-1-11	S21953001	1	ソレノイドツギテ	SOLENOID JOINT	
1-1-12	S09637001	1	ピン	PIN	
1-1-13	048040342	2	トメワE4	RETAINING RING, E4	
1-1-14	102630001	1	ハリボウアンナイカクコマ	NEEDLE BAR GUIDE SLIDE BLOCK	
1-1-15	S21954001	1	オサエアゲレバー	PRESSER BAR LIFTER LEVER	
1-1-16	S21955001	1	オサエアゲレバージク	PRESSER BAR LIFTER LEVER SHAFT	
1-1-17	014710522	2	アナトメネジ4.76クボミ	SET SCREW, SOCKET (CP) M4.76	
1-2	S21952101	3	カクネマルアタマボルト	BOLT	
1-3	021080106	3	ナツト1シユ8	NUT, 1 M8	
1-4	028080242	3	バネザガネ2-8	WASHER, SPRING 2-8	
1-5	025080236	3	ヒラザガネチユウ8	WASHER, PLAIN M 8	
1-6	146254001	6	モータカンザ	COLLAR	
1-7	021080302	12	ナツト3シユ8	NUT, 3 M8	

R. エアー押工上げ関係 / Pneumatic presser foot lifting mechanism /
 Pneumatische stoffdrückerfußanhebevorrichtung / Dispositif pneumatique de releveur de
 pied presseur / Levantador neumático del prensatelas

B276-UT23,24
 B277-UT23,44

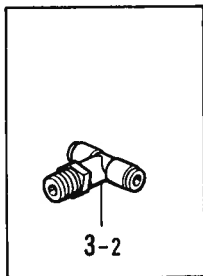
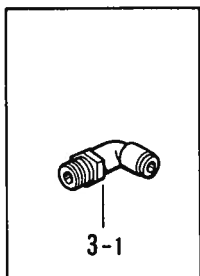
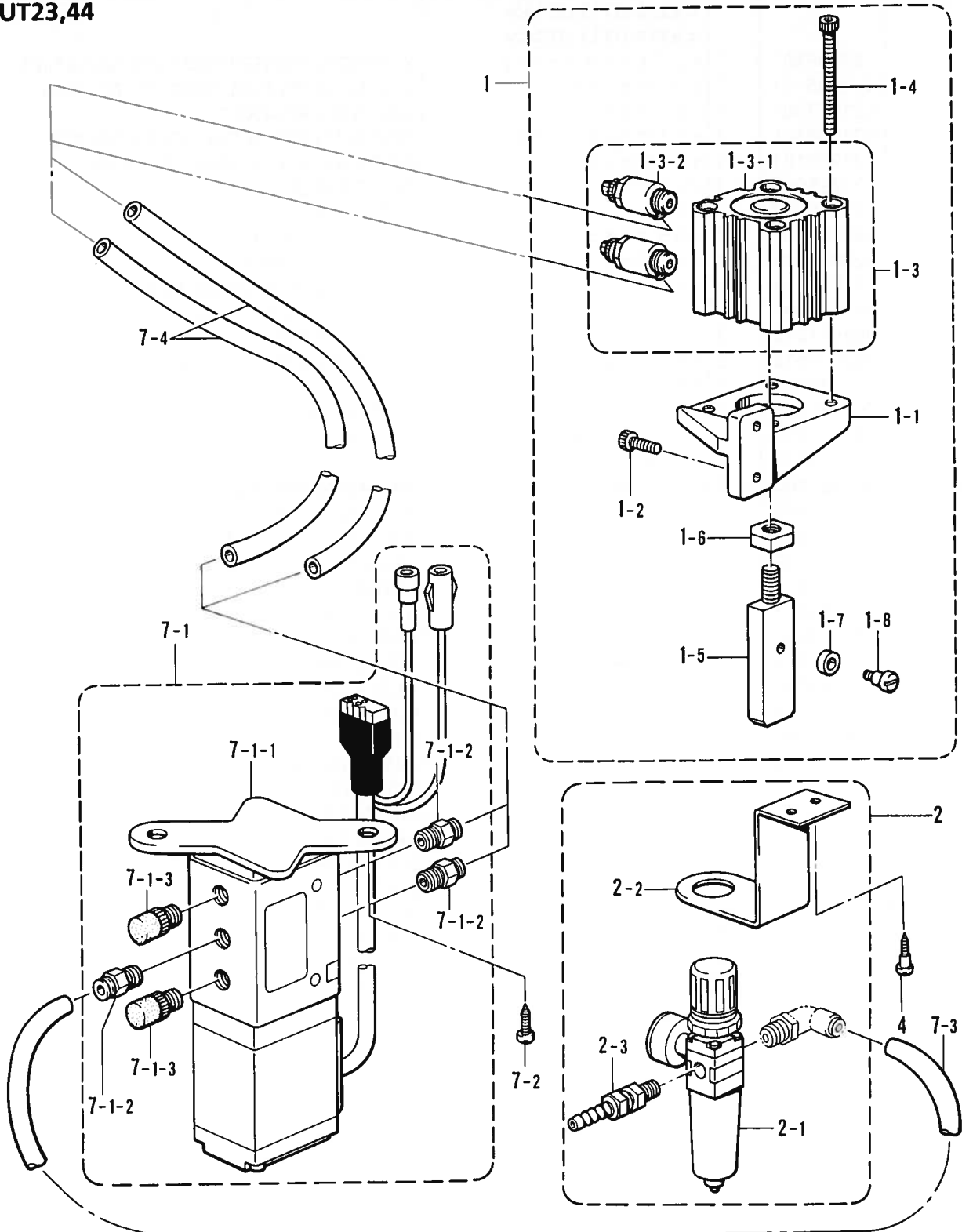

R. エアー押工上ゲ関係 / Pneumatic presser foot lifting mechanism /
Pneumatische stoffdrückerfußanhebevorrichtung / Dispositif pneumatique de releveur de
ped presseur / Levantador neumático del prensatelas

REF.NO.	CODE	Q'TY	ヒンメイ	NAME OF PARTS	RM
			<B276-UT23,24> <B277-UT23,44>		
1	S28681001	1	オサエアゲシリンダクミ	PRESSER FOOT LIFTING CYLINDER ASSY	
1-1	S28596001	1	シリンダードダイ	CYLINDER BASE	
1-2	018061222	2	アナボルト6X12	BOLT, SOCKET M6X12	
1-3	S28597000	1	エアーシリンダクミ	AIR CYLINDER ASSY	
1-3-1	S28598000	1	エアーシリンダ	AIR CYLINDER	
1-3-2	S28599000	2	スピードコントローラ	SPEED CONTROLLER	
1-4	018505022	4	アナボルト5X50	BOLT, SOCKET M5X50	
1-5	S28600001	1	オサエサドウボウ	PRESSER DRIVING BAR	
1-6	021080302	1	ナット3シユ8	NUT, 3 M8	
1-7	110167001	1	コロ	ROLLER	
1-8	110168001	1	コロジク	ROLLER SHAFT	
2	S28468001	1	エアーユニットクミ	AIR UNIT ASSY	
2-1	S21352001	1	フィルターレギュレータ	FILTER REGULATOR	
2-2	S21353001	1	エアユニットトリツケイタ	AIR UNIT SET PLATE	
2-3	140678000	1	ホースツギテ	AIR TUBE JOINT	
3-2	S28469000	1	チーズユニオン	T-UNION	
4	101118001	2	マルモクネジ4.5X20	WOOD SCREW, ROUND M4.5X20	
7	S28682001	1	オサエアゲバルブセット	PRESSER FOOT LIFTING VALVE SET	
7-1	S28683001	1	オサエアゲバルブクミ	PRESSER FOOT LIFTING VALVE ASSY	
7-1-1	S28680001	1	ソレノイドバルブクミ	SOLENOID VALVE ASSY	
7-1-2	S01522000	3	ハーフユニオン	HALF UNION	
7-1-3	159874000	2	サイレンサー	SILENCER	
7-2	032422505	2	+マルモクネジ4.1X25	WOOD SCREW, ROUND M4.1X25	
7-3	S28685000	1	エアーチューブ (L=310)	AIR TUBE (L=310)	
7-4	S28686000	2	エアーチューブ (L=900)	AIR TUBE (L=900)	
			<オプションパーツ>	< OPTION PARTS >	
3-1	S04896000	1	エルボユニオン	ELBOW UNION	

Z1. 付属品関係 / Accessories / Zubehör / Accessoires / Accesorios

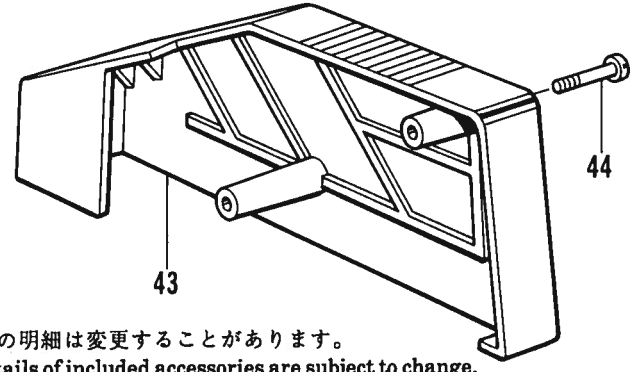
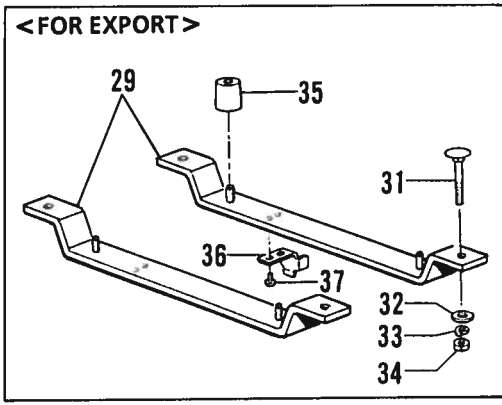
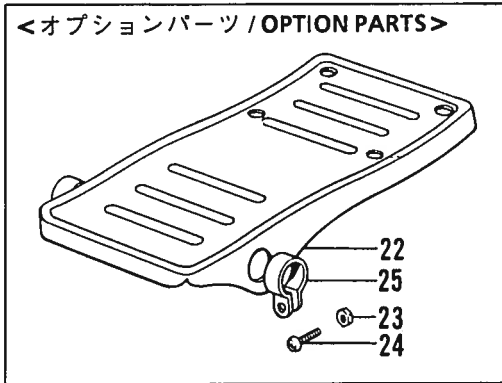
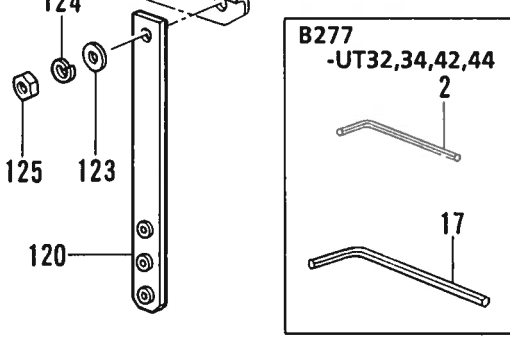
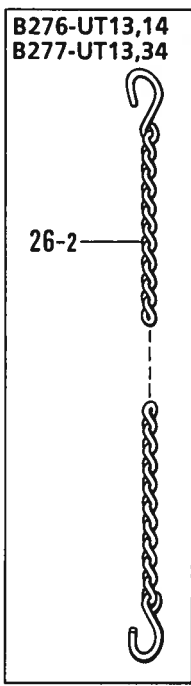
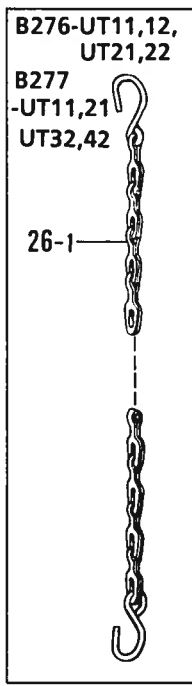
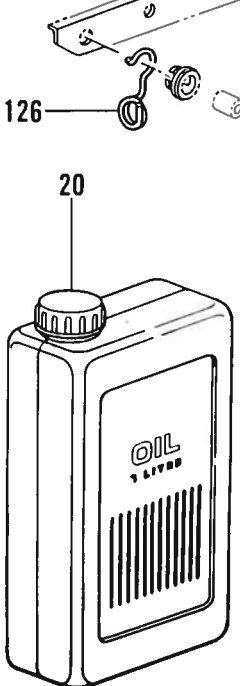
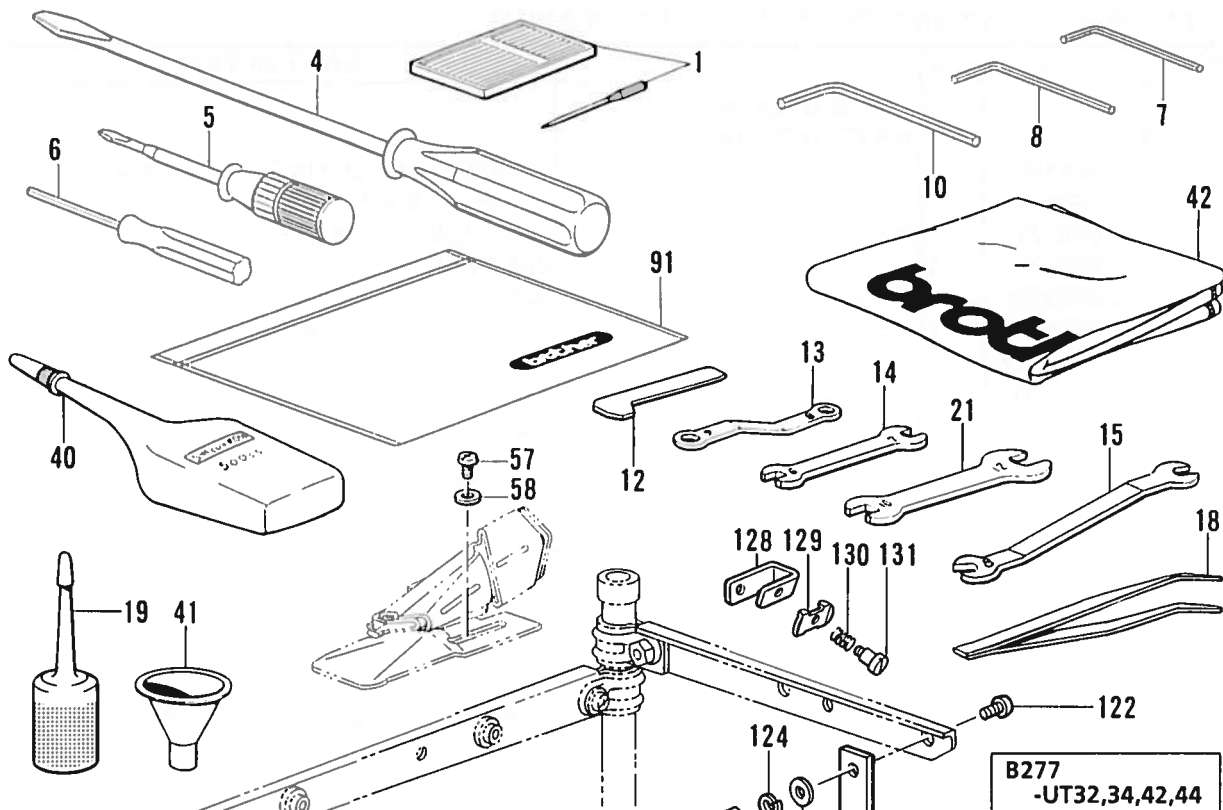

◎ 付属品の明細は変更することがあります。
 ◎ The details of included accessories are subject to change.
 ◎ Änderungen in der Aufstellung der Mitgelieferten Zubehöre sind vorbehalten.
 ◎ Les détails des accessoires inclus sont sujets à des changements.
 ◎ Los detalles de los accesorios incluidos pueden variar.

Z1. 付属品関係 / Accessories / Zubehör / Accessoires / Accesorios

REF.NO.	CODE	Q'TY	ヒンメイ	NAME OF PARTS	RM
1	S08715010	10	ミシンハリUYX128GAS	NEEDLE UYX128GAS	
4	101572101	1	ネジマワシ5.5X190	SCREW DRIVER 5.5X190	
5	118837001	1	ネジマワシ3.4X70	SCREW DRIVER 3.4X70	
6	S01943001	1	6カクボウネジマワシ1.6	SCREW DRIVER 1.6	
7	146049001	1	6カクボウスパナ2	HEXAGONAL WRENCH 2	
8	142721001	1	6カクボウスパナ3	HEXAGONAL WRENCH 3	
10	150335001	1	6カクボウスパナ5	HEXAGONAL WRENCH 5	
12	156309001	1	Lガタネジマワシ	L-TYPE SCREW DRIVER	
13	105343001	1	メガネレンチ8X9	WRENCH 8X9	
14	107779001	1	スパナ6X7	SPANNER 6X7	
15	143566001	1	スパナ8	SPANNER 8	
18	117466000	1	ピンセット	PINCETTE	
19	S06701000	1	ポリオイラークミ	POLY OILER ASSY	
20	145277105	1	オイルタンク	OIL TANK	
21	107780001	1	スパナ10X12	SPANNER 10X12	
40	S06704001	1	シリコンオイル	SILICONE OIL	
41	140759000	1	ジョーゴ	FUNNEL	
42	144224001	1	トウブカバー	HEAD COVER	
43	S09002009	1	ベルトカバー	BELT COVER	
44	102424004	2	シメネジ4.37	SCREW, M4.37	
57	062710812	2	ナベコ476-32X8	SCREW, PAN M4.76-32X8	
58	116662003	2	ザガネ	WASHER	
91	122991001	1	フソクヒンポリフクロ	ACCESSORY BAG	
120	S21943001	1	イトアンナイクミ	THREAD GUIDE ASSY	
122	062501006	1	ナベコ5X10	SCREW, PAN M5X10	
123	025050236	1	ヒラザガネチユウ-5	WASHER, PLAIN M 5	
124	028050246	1	バネザガネ2-5	WASHER, SPRING 2-5	
125	021500106	1	1シユナツト5	NUT, 1 M5	
126	S02747101	1	イトカケバネ	SPRING	
128	S08984001	1	サブテンシヨンドダイ	SUB TENSION BASE	
129	112300001	1	ハリイトオサエ	NEEDLE THREAD CLAMP	
130	112299001	1	ハリイトアンナイオシバネ	COIL SPRING	
131	112301001	1	ダンネジ3.18	STUD SCREW, M3.18	
<B277-UT32,34,42,44>					
2	154125001	1	6カクボウスパナ2.5	HEXAGONAL WRENCH 2.5	
17	118064001	1	6カクボウスパナ4	HEXAGONAL WRENCH 4	
<B276-UT11,12,21,22>					
<B277-UT11,21,32,42>					
26-1	149247001	1	クサリクミ	CHAIN ASSY	
<B276-UT13,14>					
<B277-UT13,34>					
26-2	S21942001	1	クサリクミ	CHAIN ASSY	
<オプションパーツ / OPTION PARTS>					
22	147893009	1	オサエアゲフミイタ	TREADLE PEDAL	
23	021400106	2	ナツト1シユ4	NUT, 1 M4	
24	062401406	2	ナベコ4X14	SCREW, PAN M4X14	
25	116016001	2	ペタルトメ	PEDAL STOPPER	
<輸出用 / FOR EXPORT>					
29	S25099001	2	-----	MACHINE BASE PLATE ASSY	
31	211964001	4	-----	BOLT, M8X55	
32	025080236	4	-----	WASHER, PLAIN M 8	
33	028080242	4	-----	WASHER, SPRING 2-8	
34	021080106	4	-----	NUT, 1 M8	
35	147919001	4	-----	RUBBER CUSHION	
36	S09001101	1	-----	CHAIN GUIDE	
37	060680712	2	-----	SCREW, BIND M4.37-40X7	

B276

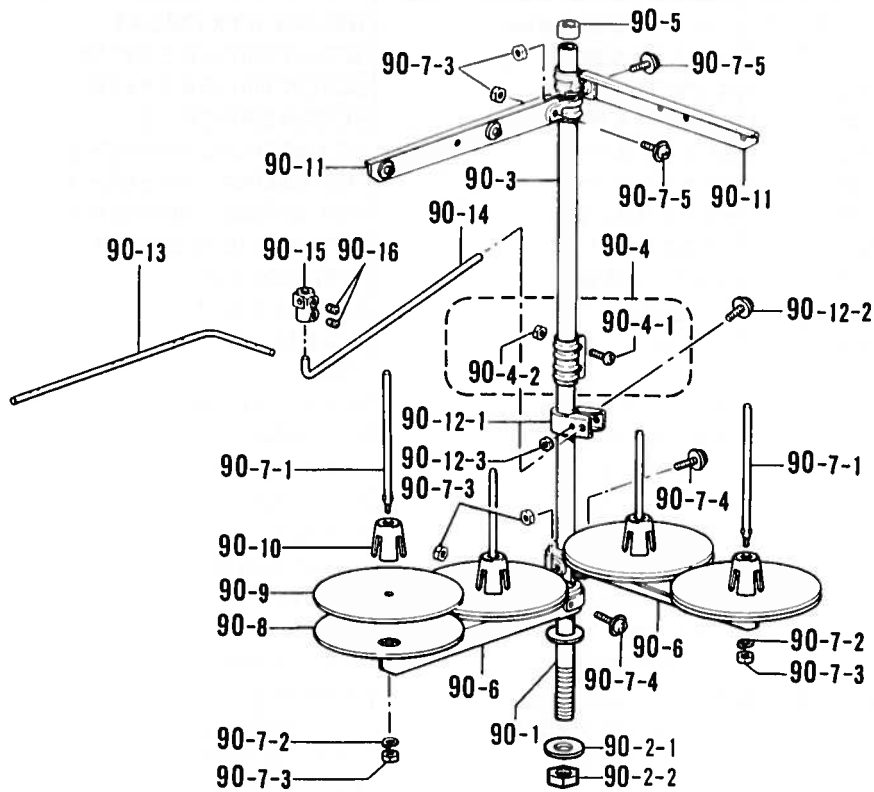

<オプションパーツ / OPTION PARTS >

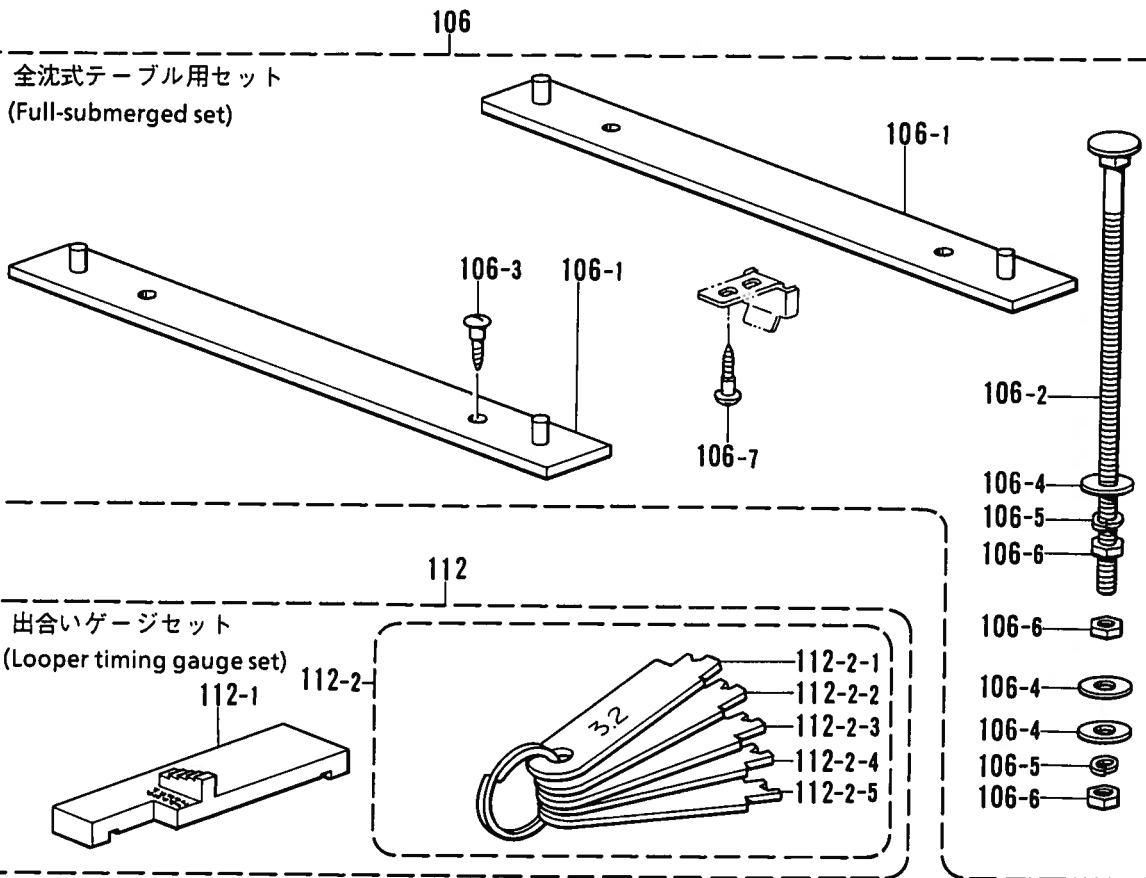

- ◎ 付属品の明細は変更することがあります。
- ◎ The details of included accessories are subject to change.
- ◎ Änderungen in der Aufstellung der Mitgelieferten Zubehöre sind vorbehalten.
- ◎ Les détails des accessoires inclus sont sujets à des changements.
- ◎ Los detalles de los accesorios incluidos pueden variar.

Z2. 付属品関係 / Accessories / Zubehör / Accessoires / Accesorios

REF.NO.	CODE	Q'TY	ヒンメイ	NAME OF PARTS	RM
			<B276>		
90	S29854009	1	イトタテダイクミ4DTHF	COTTON STAND ASSY 4DTHF	
90-1	156112003	1	コラムパイプD	COLUMN PIPE (D)	
90-2	S02775001	1	パイプネジセットA	COLUMN PIPE SCREW SET (A)	
90-2-1	150206002	1	ヒラザガネ16	WASHER, PLAIN M16	
90-2-2	150191002	1	6カクナット5/8	NUT, 5/8	
90-3	150172003	1	コラムパイプ	COLUMN PIPE	
90-4	150106003	1	コラムジョイントクミ	COLUMN JOINT ASSY	
90-4-1	062501406	2	ナベコ5X14	SCREW, PAN M5X14	
90-4-2	021500106	2	1シユナツト5	NUT, 1 M5	
90-5	150174000	1	コラムキャップ	COLUMN CAP	
90-6	S02778002	2	スプールホルダー2	SPOOL HOLDER 2	
90-7	S02780001	2	スプールネジセット2	SPOOL SCREW SET 2	
90-7-1	150179002	4	スプールジクB	SPOOL SHAFT B	
90-7-2	028050246	4	バネザガネ2-5	WASHER, SPRING 2-5	
90-7-3	021500106	8	1シユナツト5	NUT, 1 M5	
90-7-4	0A1503006	2	+ナベザクミ5X30A	SCREW, PAN (P WASHER) M5X30A	
90-7-5	0A1501406	2	+ナベザクミ5X14A	SCREW, PAN (P WASHER) M5X14A	
90-8	150180001	4	ウケザラ	SPOOL STAND BASE	
90-9	150182000	4	スプールのマット	SPOOL MAT	
90-10	126863001	4	スプールのクッション	SPOOL CUSHION	
90-11	S02786002	2	スレツドハンガークミ2	THREAD HANGER ASSY 2	
90-12	150145009	1	イトアンナイホルダークミ	THREAD GUIDE HOLDER ASSY	
90-12-1	150185009	1	イトアンナイホルダー	THREAD GUIDE HOLDER	
90-12-2	0A1503006	1	+ナベザクミ5X30A	SCREW, PAN (P WASHER) M5X30A	
90-12-3	021500106	1	1シユナツト5	NUT, 1 M5	
90-13	142998101	1	イトアンナイ4	THREAD GUIDE 4	
90-14	S04109001	1	イトアンナイササエボウ	THREAD GUIDE SUPPORT BAR	
90-15	138843001	1	ササエボウツギテ	JOINT	
90-16	014060632	2	アナトメ6X6クボミ	SET SCREW, SOCKET (CP) M6X6	
			<オプションパーツ>	<OPTION PARTS>	
106	S11560001	1	フルサブマーゲセット	FULL SUBMERGED SET	
106-1	S11561001	2	トウブウケイタ	HEAD SPOOL PLATE	
106-2	S11562001	4	カクネマルアタマボルト	BOLT	
106-3	100666002	4	マルモクネジ5.5X20	SCREW, OVAL M5.5X20	
106-4	025080336	12	ヒラザガネダイ8	WASHER, PLAIN L8	
106-5	028080242	8	バネザガネ2-8	WASHER, SPRING 2-8	
106-6	021080106	12	ナツト1シユ8	NUT, 1 M8	
106-7	032461606	2	+マルモクネジ4.5X16	WOOD SCREW, ROUND M4.5X16	
112	S13714001	1	デアイゲージセット	LOOPER TIMING GAUGE SET	
112-1	S13715001	1	デアイゲージブロック	GAUGE BLOCK	
112-2	S13716001	1	デアイゲージイタクミ	GAUGE PLATE ASSY	
112-2-1	S13717001	1	デアイゲージイタ3.2	GAUGE PLATE (3.2)	
112-2-2	S13718001	1	デアイゲージイタ4.0	GAUGE PLATE (4.0)	
112-2-3	S13719001	1	デアイゲージイタ4.8	GAUGE PLATE (4.8)	
112-2-4	S13720001	1	デアイゲージイタ5.6	GAUGE PLATE (5.6)	
112-2-5	S13721001	1	デアイゲージイタ6.4	GAUGE PLATE (6.4)	

B277

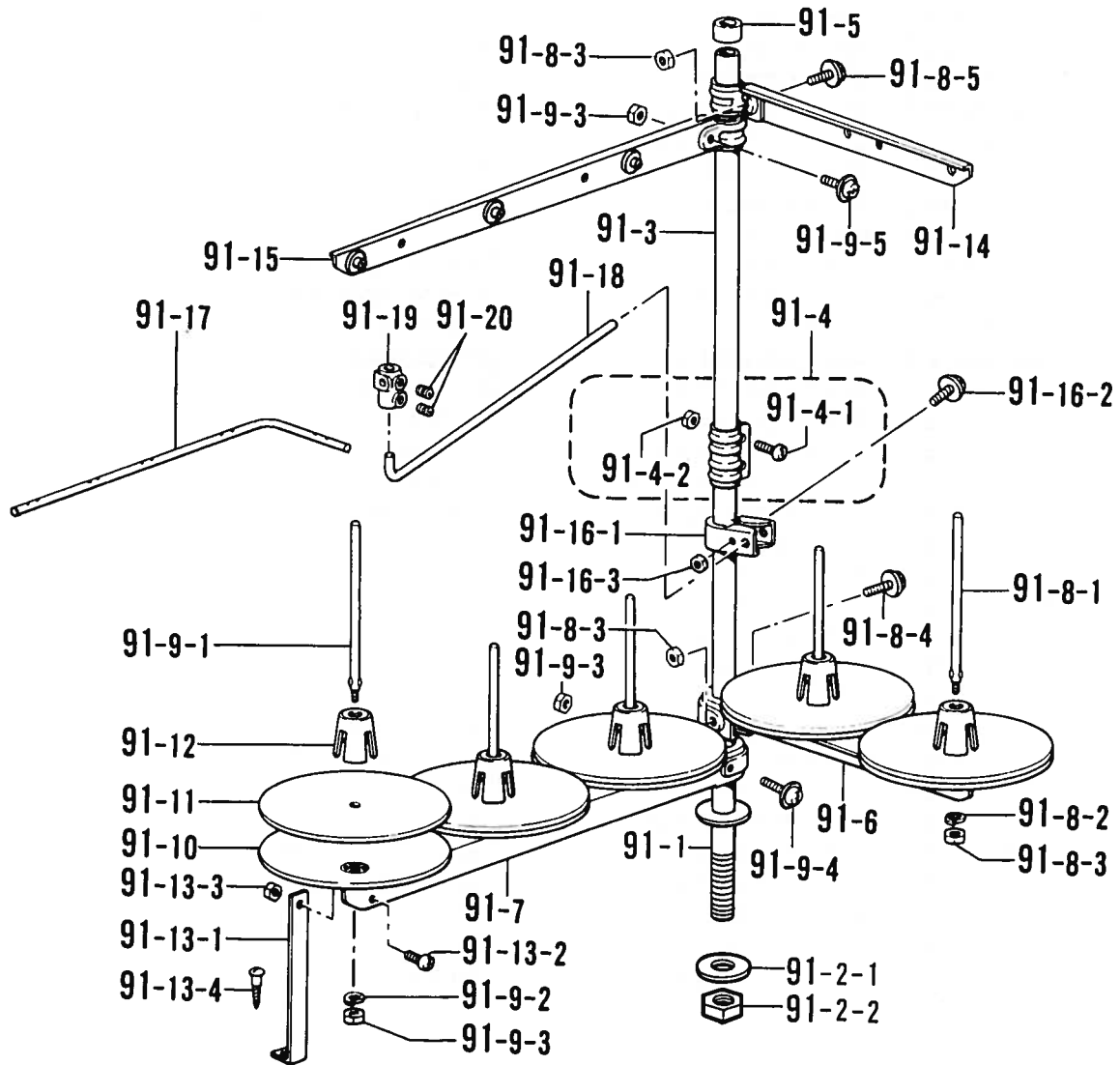







- ◎ 付属品の明細は変更することがあります。
- ◎ The details of included accessories are subject to change.
- ◎ Änderungen in der Aufstellung der Mitgelieferten Zubehöre sind vorbehalten.
- ◎ Les détails des accessoires inclus sont sujets à des changements.
- ◎ Los detalles de los accesorios incluidos pueden variar.



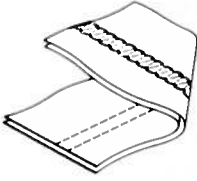
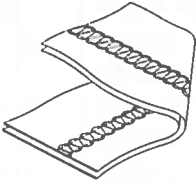
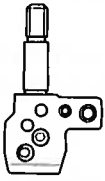
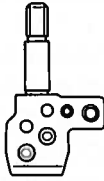
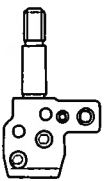
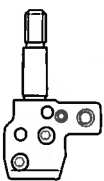
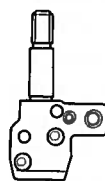
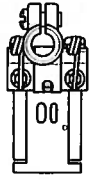
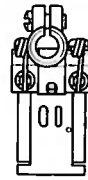
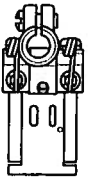
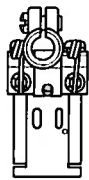

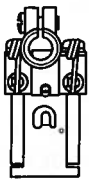

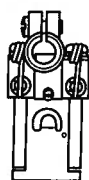
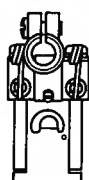

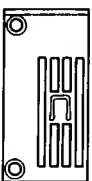
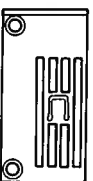
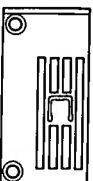
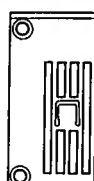
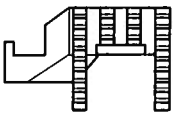
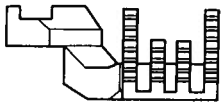
Z3. 付属品関係 / Accessories / Zubehör / Accessoires / Accesorios

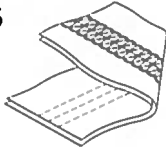
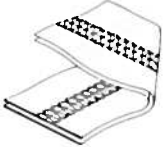
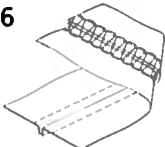
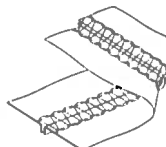



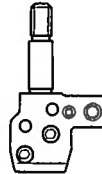
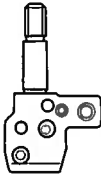
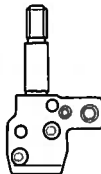
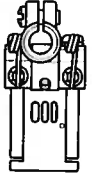
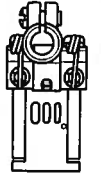
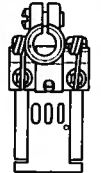
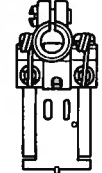
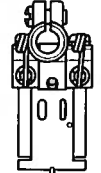
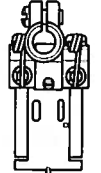
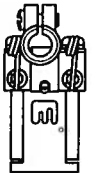
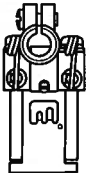
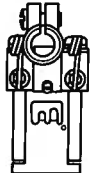
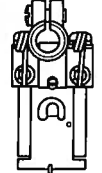
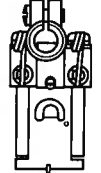
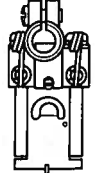



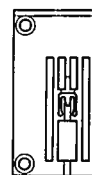
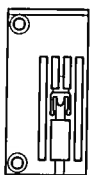
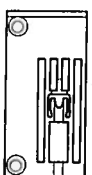
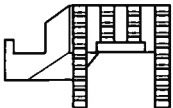
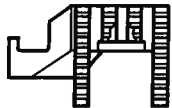
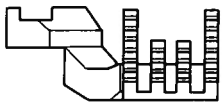
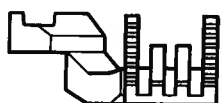

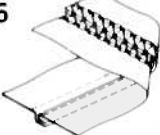
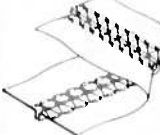
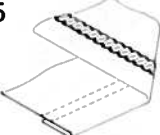
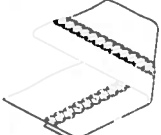



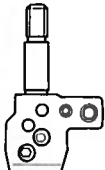
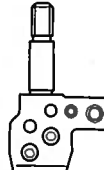
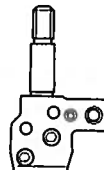
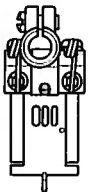

REF.NO.	CODE	Q'TY	ヒンメイ	NAME OF PARTS	RM
			<B277>		
91	S29855009	1	イトタテダイクミ5DTHF	COTTON STAND ASSY (5DTHF)	
91-1	156112003	1	コラムパイプD	COLUMN PIPE (D)	
91-2	S02775001	1	パイプネジセットA	COLUMN PIPE SCREW SET (A)	
91-2-1	150206002	1	ヒラザガネ16	WASHER, PLAIN M16	
91-2-2	150191002	1	6カクナット5/8	NUT, 5/8	
91-3	150172003	1	コラムパイプ	COLUMN PIPE	
91-4	150106003	1	コラムジョイントクミ	COLUMN JOINT ASSY	
91-4-1	062501406	2	ナベコ5X14	SCREW, PAN M5X14	
91-4-2	021500106	2	1シユナツト5	NUT, 1 M5	
91-5	150174000	1	コラムキャップ	COLUMN CAP	
91-6	S02778002	1	スプールホルダー2	SPOOL HOLDER 2	
91-7	S02779009	1	スプールホルダー3	SPOOL HOLDER 3	
91-8	S02780001	1	スプールネジセット2	SPOOL SCREW SET 2	
91-8-1	150179002	2	スプールジクB	SPOOL SHAFT (B)	
91-8-2	028050246	2	バネザガネ2-5	WASHER, SPRING 2-5	
91-8-3	021500106	4	1シユナツト5	NUT, 1 M5	
91-8-4	0A1503006	1	+ナベザクミ5X30A	SCREW, PAN (P WASHER) M5X30A	
91-8-5	0A1501406	1	+ナベザクミ5X14A	SCREW, PAN (P WASHER) M5X14A	
91-9	S02782001	1	スプールネジセット3	SPOOL SCREW SET 3	
91-9-1	150179002	3	スプールジクB	SPOOL SHAFT (B)	
91-9-2	028050246	3	バネザガネ2-5	WASHER, SPRING 2-5	
91-9-3	021500106	5	1シユナツト5	NUT, 1 M5	
91-9-4	0A1503006	1	+ナベザクミ5X30A	SCREW, PAN (P WASHER) M5X30A	
91-9-5	0A1501406	1	+ナベザクミ5X14A	SCREW, PAN (P WASHER) M5X14A	
91-10	150180001	5	ウケザラ	SPOOL STAND BASE	
91-11	150182000	5	スプールマット	SPOOL MAT	
91-12	126863001	5	スプールクツシヨン	SPOOL CUSHION	
91-13	S02784009	1	ホルダーササエAセット	HOLDER SUPPORT (A) SET	
91-13-1	150188009	1	スプールホルダーササエA	SPOOL HOLDER SUPPORT (A)	
91-13-2	062501006	1	ナベコ5X10	SCREW, PAN M5X10	
91-13-3	021500106	1	1シユナツト5	NUT, 1 M5	
91-13-4	031452206	1	マルモク45X22	WOOD SCREW, ROUND M4.5X22	
91-14	S02786002	1	スレツドハンガークミ2	THREAD HANGER ASSY 2	
91-15	S02788009	1	スレツドハンガークミ3	THREAD HANGER ASSY 3	
91-16	150145009	1	イトアンナイホルダークミ	THREAD GUIDE HOLDER ASSY	
91-16-1	150185009	1	イトアンナイホルダー	THREAD GUIDE HOLDER	
91-16-2	0A1503006	1	+ナベザクミ5X30A	SCREW, PAN (P WASHER) M5X30A	
91-16-3	021500106	1	1シユナツト5	NUT, 1 M5	
91-17	142999101	1	イトアンナイ5	THREAD GUIDE 5	
91-18	S04109001	1	イトアンナイササエボウ	THREAD GUIDE SUPPORT BAR	
91-19	138843001	1	ササエボウツギテ	JOINT	
91-20	014060632	2	アナトメ6X6クボミ	SET SCREW, SOCKET (CP) M6X6	

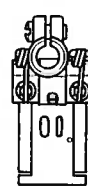

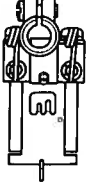
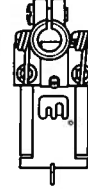
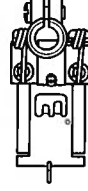
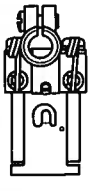

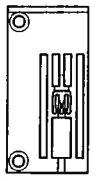

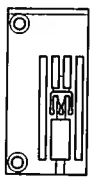
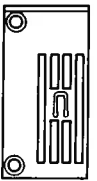
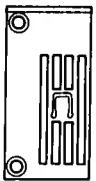

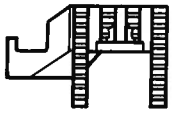
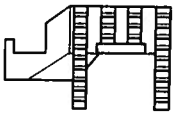
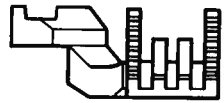
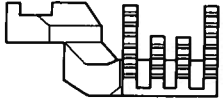

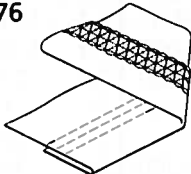
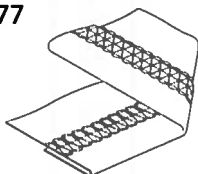
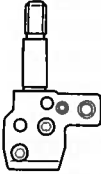
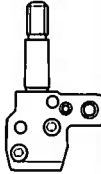



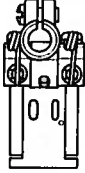
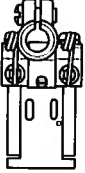

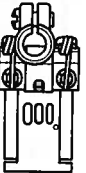
ゲージ部品一覧表 / GAUGE PARTS LIST / LEHRENLISTE /
 LISTE DES PIÈCES D'ECARTEMENT / LISTA DE PIEZAS DE CALIBRADORES

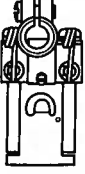
1/4

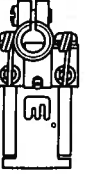
機種 Model	B276 B277	B276 B277	B276 B277	B276 B277	B276 B277	
仕様 Specifications	011-1	011-2	011-3	011-4	011-5	
仕様ラベル Label	S08678-001	S08678-002	S08678-003	S08678-004	S08678-005	
用途 Application	地縫用 For plain stitching <div style="display: flex; justify-content: space-around; align-items: center;"> <div style="text-align: center;"> B276  </div> <div style="text-align: center;"> B277  </div> </div>					
針数(本) No. of needles	2	2	2	2	2	
針幅(mm) Needle spacing	3.2	4.0	4.8	5.6	6.4	
針止メ組 Needle clamp assy	 S08699-001	 S08701-001	 S08703-001	 S08705-001	 S08707-001	
押工組 Presser foot assy (B276)	 S21832-001	 S21834-001	 S21836-001	 S21838-001	 S21840-001	
押工組 Presser foot assy (B277)	 S08779-201	 S08786-201	 S08788-201	 S08790-201	 S08792-201	
針板 Needle plate	 S08717-001	 S08718-001	 S08719-001	 S08720-001	 S08721-001	
主送り歯 Main feed dog	 S08882-001					
差動送り歯 Differential feed dog	 S08885-001					

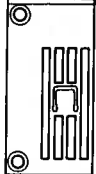
機種 Model	B276 B277	B276 B277	B276 B277	B276 B277	B276 B277	B276 B277
仕様 Specifications	011-6	011-7	011-8	033-3	033-4	033-5
仕様ラベル Label	S08678-006	S08678-007	S08678-008	S08678-064	S08678-065	S08678-066
用途 Application	地縫用 / For plain stitching B276  B277 			カバーリング用 / For covering B276  B277 		
針数(本) No. of needles	3	3	3	2	2	2
針幅(mm) Needle spacing	4.8	5.6	6.4	4.8	5.6	6.4
針止メ組 Needle clamp assy	 S08709-001	 S08711-001	 S08713-001	 S08703-001	 S08705-001	 S08707-001
押工組 Presser foot assy (B276)	 S21842-001	 S21844-001	 S21846-001	 S21848-001	 S21850-001	 S21852-001
押工組 Presser foot assy (B277)	 S08794-201	 S08796-201	 S08798-201	 S08828-201	 S08830-201	 S08832-201
針板 Needle plate	 S08722-001	 S08723-001	 S08724-001	 S21823-001	 S21824-001	 S21825-001
主送り歯 Main feed dog	 S08882-001			 S21860-001		
差動送り歯 Differential feed dog	 S08885-001			 S21861-001		

機種 Model	B276 B277	B276 B277	B276 B277	B276 B277	B276 B277	B276 B277
仕様 Specifications	033-6	033-7	033-8	051-1	051-2	051-3
仕様ラベル Label	S08678-067	S08678-068	S08678-069	S08678-056	S08678-057	S08678-058
用途 Application	カバーリング用 / For covering B276  B277 			ヘム縫用 / For hem stitching B276  B277 		
針数(本) No. of needles	3	3	3	2	2	2
針幅(mm) Needle spacing	4.8	5.6	6.4	3.2	4.0	4.8
針止×組 Needle clamp assy	 S08709-001	 S08711-001	 S08713-001	 S08699-001	 S08701-001	 S08703-001
押工組 Presser foot assy (B276)	 S21854-001	 S21856-001	 S21858-001	 S21832-001	 S21834-001	 S21836-001
押工組 Presser foot assy (B277)	 S08834-201	 S08836-201	 S08838-201	 S08779-201	 S08786-201	 S08788-201
針板 Needle plate	 S21826-001	 S21827-001	 S21828-001	 S08717-001	 S08718-001	 S08719-001
主送り歯 Main feed dog	 S21860-001			 S08882-001		
差動送り歯 Differential feed dog	 S21861-001			 S08885-001		

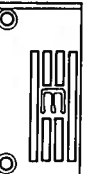
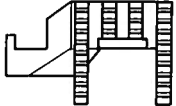
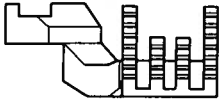
機種 Model	B276 B277	B276 B277	B276 B277	B276 B277	B276 B277	
仕様 Specifications	051-4	051-5	051-6	051-7	051-8	
仕様ラベル Label	S08678-059	S08678-060	S08678-061	S08678-062	S08678-063	
用途 Application	ヘム縫用 For hem stitching <div style="display: flex; justify-content: space-around; align-items: center;"> <div style="text-align: center;"> <p>B276</p>  </div> <div style="text-align: center;"> <p>B277</p>  </div> </div>					
針数(本) No. of needles	2	2	3	3	3	
針幅(mm) Needle spacing	5.6	6.4	4.8	5.6	6.4	
針止メ組 Needle clamp assy	 S08705-001	 S08707-001	 S08709-001	 S08711-001	 S08713-001	
押工組 Presser foot assy (B276)	 S21838-001	 S21840-001	 S21842-001	 S21844-001	 S21846-001	
押工組 Presser foot assy (B277)	 S08790-201	 S08792-201	 S08794201	 S08796201	 S08798-201	
針板 Needle plate	 S08720-001	 S08721-001	 S08722-001	 S08723-001	 S08724-001	
主送り歯 Main feed dog	 S08882-001					
差動送り歯 Differential feed dog	 S08885-001					

索引/INDEX/VERZEICHIS/
INDEX/INDICE

CODE	REF.NO.	Page
J00102001	M - 1	32
J00103001	M - 1-9	32
S00017001	A1 - 102	2
S00313009	A1 - 26	2
	A1 - 123	4
S00356001	K1 - 51	24
	K2 - 51	28
S00383001	K1 - 52	24
	K2 - 52	28
S00879001	D - 25	10
S01297001	E - 34	12
S01374001	D - 40-1-4	10
	D - 40-2-4	10
S01522000	R - 7-1-2	46
	N2 - 86-2	40
S01542000	N2 - 86-3	40
S01696001	P - 14	42
S01943001	Z2 - 6	48
S02592009	Q - 1-1-5	44
S02606000	A1 - 5	2
S02745001	Q - 1-1-3-4	44
	N1 - 69	36
	N2 - 69	40
S02747101	Z2 - 126	48
S02775001	Z2 - 90-2	50
	Z3 - 91-2	52
S02778002	Z2 - 90-6	50
	Z3 - 91-6	52
S02779009	Z3 - 91-7	52
S02780001	Z2 - 90-7	50
	Z3 - 91-8	52
S02782001	Z3 - 91-9	52
S02784009	Z3 - 91-13	52
S02786002	Z2 - 90-11	50
	Z3 - 91-14	52
S02788009	Z3 - 91-15	52
S02874001	B - 4-3	6
S03421001	J - 13	22
S03704001	C - 50	8
	E - 46	14
	G - 24	18
S04109001	Z2 - 90-14	50
	Z3 - 91-18	52
S04159000	N1 - 68	36
	N1 - 77	36
	N2 - 68	40
	N2 - 77	40
S04896000	R - 3-1	46
S05981000	Q - 1-1-3-8	44
S05982000	Q - 1-1-3-9	44
S06701000	Z2 - 19	48
S06704001	Z2 - 40	48
S07350001	P - 2	42
S08467000	E - 68	14
S08627001	A1 - 2	2
S08628000	A1 - 3	2
S08629009	A1 - 12	2
S08630201	A1 - 14-1	2
S08631000	A1 - 15	2
S08632009	A1 - 19	2
S08633101	A1 - 27	2
S08639000	A1 - 35	2
S08642001	A1 - 38	2
S08646100	A1 - 40	2
S08651001	A1 - 42	2

CODE	REF.NO.	Page
S08652000	A1 - 43	2
S08653001	A1 - 48	2
S08665001	A1 - 100	2
S08667001	A1 - 105	2
S08668001	A1 - 108	2
S08669001	A1 - 115	2
S08670000	A1 - 116	4
S08672000	A1 - 120	4
S08673000	A1 - 124	4
	A1 - 128	4
S08674000	A1 - 138	4
S08675000	A1 - 139	4
S08682001	C - 3	8
S08683000	C - 4	8
S08684101	C - 6	8
S08685001	C - 6-1	8
S08686101	C - 6-2	8
S08687001	C - 8	8
S08688001	C - 9	8
S08689001	C - 11	8
S08692101	C - 16	8
S08693001	C - 16-1	8
S08694001	C - 16-2	8
S08696000	C - 23	8
S08697000	C - 24	8
S08698001	C - 25	8
S08715010	C - 31	8
	C - 31	8
	Z2 - 1	48
S08716201	C - 35	8
S08750001	C - 42	8
S08751001	C - 44	8
S08752001	C - 46	8
S08753000	C - 48	8
S08754000	C - 49	8
	G - 23	18
S08755001	C - 51	8
S08756001	C - 53	8
S08757001	C - 55	8
S08758009	B - 1	6
S08760009	B - 1-1	6
S08761100	B - 3	6
S08762101	B - 4	6
S08764100	B - 4-1	6
S08765000	B - 4-2	6
S08766000	B - 6	6
S08769001	D - 6	10
S08770000	D - 12	10
	G - 7	18
	K1 - 49	24
	K2 - 49	28
S08771001	D - 14	10
S08774001	D - 18	10
S08775000	D - 28	10
S08776001	D - 30	10
S08777001	D - 31	10
S08782101	D - 40-1-1	10
	D - 40-2-1	10
S08783101	D - 40-1-3	10
	D - 40-2-3	10
S08784001	D - 40-1-6	10
	D - 40-2-6	10
S08785001	D - 40-1-8	10
	D - 40-2-8	10
S08870001	E - 8	12

CODE	REF.NO.	Page
S08871001	E - 10	12
S08872001	E - 20	12
S08873001	E - 20-1	12
S08876000	E - 36	12
S08877001	E - 44	14
S08878001	E - 52	14
S08879001	E - 55	14
S08880001	E - 56	14
S08881101	E - 62	14
S08889101	F - 1	16
S08890001	F - 1-1	16
S08891001	F - 5	16
S08892001	F - 8	16
S08895001	F - 10-1	16
S08895002	F - 10-2	16
S08895003	F - 10-3	16
S08896101	F - 11	16
S08897001	F - 11-1	16
S08898000	F - 13	16
S08899001	F - 14	16
S08900000	F - 16	16
S08903000	F - 17	16
S08904000	F - 20	16
S08906001	G - 1	18
S08910001	G - 5	18
S08911000	G - 8	18
S08912001	G - 10	18
S08914001	G - 16	18
S08915001	G - 19	18
S08916001	G - 21	18
S08917000	G - 22	18
S08918001	G - 25	18
S08919001	G - 28	18
S08920001	G - 29	18
S08921101	G - 31	18
S08923101	J - 1	22
S08926101	J - 4	22
S08927001	J - 10	22
S08928001	J - 15	22
S08929001	J - 15-1	22
S08930001	J - 15-2	22
S08931001	J - 19	22
S08932000	J - 20	22
S08933001	J - 24	22
S08935001	H - 1	20
S08936201	H - 3	20
S08937101	H - 3-4	20
S08939100	H - 3-6	20
S08940000	H - 6	20
S08943000	H - 12	20
S08944001	H - 13	20
S08945001	H - 16	20
S08946000	H - 18	20
S08947001	H - 19	20
S08948001	H - 22	20
S08951001	H - 26	20
S08953001	H - 37	20
S08955001	H - 32	20
S08956000	H - 34	20
S08957001	H - 35	20
S08958001	H - 40	20
S08961101	K1 - 1	24
	K2 - 1	28
S08962109	K1 - 6	24
	K2 - 6	28

索引/INDEX/VERZEICHIS/
INDEX/INDICE

CODE	REF.NO.	Page
S08963001	K1 - 10	24
	K2 - 10	28
S08967001	F - 19	16
S08969101	K1 - 40	24
	K2 - 40	28
S08970001	K1 - 91	24
	K2 - 43	28
	K2 - 91	30
S08971201	K1 - 45	24
	K2 - 45	28
S08973101	K1 -45-2	24
	K2 -45-2	28
S08976001	K1 - 50	24
	K2 - 50	28
S08977001	K1 - 54	24
	K2 - 54	28
S08978001	K1 - 57	24
	K2 - 57	28
S08979001	K2 - 60	28
S08980001	K2 - 61	28
S08981001	K1 - 68	24
	K2 - 68	28
S08982001	K1 - 70	24
	K2 - 70	28
S08983001	K1 - 72	24
	K2 - 72	28
S08984001	Z2 - 128	48
S08985001	K2 - 78	28
S08986001	K2 - 80	30
S08987001	K1 - 104	26
	K2 - 81	30
	K2 - 104	30
S08988001	K2 - 85	30
S08989001	K1 - 87	24
	K2 - 87	30
S08992001	K1 - 102	26
	K2 - 102	30
S08993101	K1 - 108	26
	K2 - 108	30
S08994001	K1 - 111	26
	K2 - 111	30
S08995001	K1 - 116	26
	K2 - 116	30
S09001101	Z2 - 36	48
S09002009	Z2 - 43	48
S09043000	N1 - 3	34
	N2 - 3	38
S09120001	C - 16-3	8
S09121001	C - 41	8
S09123101	A1 - 34	2
S09124001	C - 38	8
S09125001	H - 45	20
S09251001	G - 31-1	18
S09316000	H - 42	20
S09637001	Q - 1-1-12	44
S10243000	L - 29	32
S10656001	J - 1-1	22
S10657001	K1 -45-1	24
	K2 -45-1	28
S10696027	A1 - 154	4
S10696028	A1 - 154	4
S10696029	A1 - 154	4
S10696030	A1 - 154	4
S10696031	A1 - 154	4
S10696032	A1 - 154	4

CODE	REF.NO.	Page
S10696033	A1 - 154	4
S10696034	A1 - 154	4
S10696035	A1 - 154	4
S10696036	A1 - 154	4
S10696037	A1 - 154	4
S10696038	A1 - 154	4
S11560001	Z2 - 106	50
S11561001	Z2 - 106-1	50
S11562001	Z2 - 106-2	50
S13385001	C - 39	8
S13714001	Z2 - 112	50
S13715001	Z2 - 112-1	50
S13716001	Z2 - 112-2	50
S13717001	Z2 - 112-2-1	50
S13718001	Z2 - 112-2-2	50
S13719001	Z2 - 112-2-3	50
S13720001	Z2 - 112-2-4	50
S13721001	Z2 - 112-2-5	50
S13809001	J - 6	22
S14085011	L - 25	32
S14621001	C - 1-2	8
S14622001	F - 1-2	16
S14623001	F - 11-2	16
S16249001	E - 75	14
S16385001	N1 - 51	34
	N2 - 51	38
S16498001	E - 1-1	12
S18530001	K1 - 94	24
	K2 - 94	30
S18532001	K1 - 96	26
	K2 - 96	30
S18534001	K1 - 98	26
	K2 - 98	30
S18535001	K1 - 100	26
	K2 - 100	30
S21352001	R - 2-1	46
S21353001	R - 2-2	46
S21813001	A1 - 31	2
S21814001	A1 - 33	2
S21815001	A1 - 36	2
S21816001	A1 -41-1	2
S21817001	A2 -41-2	6
S21821009	C - 1	8
S21822009	C - 1-1	8
S21829001	D - 1	10
S21830001	D - 2	10
S21862001	A2 - 155	6
S21863001	A2 - 156	6
S21864001	A2 - 159	6
S21865001	A2 - 160	6
S21866001	G - 12	18
S21867001	L - 1	32
S21868101	L - 3	32
S21871101	L - 4	32
S21872101	L - 6	32
S21873001	L - 8	32
S21874000	L - 9	32
S21875001	L - 10	32
S21876001	L - 12	32
S21877001	L - 14	32
S21878001	K1 - 11	24
	K2 - 11	28
S21879001	K1 - 27	24
	K2 - 27	28
S21880001	K1 - 28	24

CODE	REF.NO.	Page
S21880001	K2 - 28	28
S21881001	K1 - 29	24
	K2 - 29	28
S21882001	K1 - 30	24
	K2 - 30	28
S21883001	K1 - 31	24
	K2 - 31	28
S21884001	K1 - 120	26
	K2 - 120	30
S21885001	K1 - 122	26
	K2 - 122	30
S21886001	K1 - 124	26
	K2 - 124	30
S21887001	K1 - 125	26
	K2 - 125	30
S21888001	K1 - 128	26
	K2 - 128	30
S21891001	K1 - 129	26
	K2 - 129	30
S21893001	K1 - 131	26
	K2 - 131	30
S21894001	K1 - 134	26
	K2 - 134	30
S21895001	N1 - 1	34
S21896001	N1 - 1-1	34
S21897000	N1 - 1-2	34
S21898001	N1 - 1-3	34
S21899000	Q - 1-1-2-2	44
	N1 - 1-5	34
S21900001	N1 - 1-7	34
	N2 - 83	40
S21901001	N1 - 2	34
S21902001	N1 - 6	34
	N2 - 6	38
S21903001	N1 - 10	34
	N2 - 10	38
S21904001	N1 - 13	34
	N2 - 13	38
S21905001	N1 - 14	34
	N2 - 14	38
S21906001	N1 - 16	34
	N2 - 16	38
S21907001	N1 - 17	34
	N2 - 17	38
S21908001	N1 - 19	34
	N2 - 19	38
S21909001	N1 - 20	34
	N1 - 52	36
	N2 - 20	38
	N2 - 52	38
S21910001	N1 - 22	34
	N2 - 22	38
S21911001	N1 - 23	34
	N2 - 23	38
S21912000	N1 - 25	34
	N2 - 25	38
S21913001	N1 - 26	34
	N2 - 26	38
S21914001	N1 - 29	34
	N2 - 29	38
S21915001	N1 - 30	34
	N2 - 30	38
S21916001	N1 - 31	34
	N2 - 31	38
S21917001	N1 - 32	34

索引/INDEX/VERZEICHIS/
INDEX/INDICE

CODE	REF.NO.	Page
S21917001	N2 - 32	38
S21918001	N1 - 33	34
	N2 - 33	38
S21919001	N1 - 34	34
	N2 - 34	38
S21920001	N1 - 35	34
	N2 - 35	38
S21921001	N1 - 36	34
	N2 - 36	38
S21922001	N1 - 37	34
	N2 - 37	38
S21923001	N1 - 39	34
	N2 - 39	38
S21924001	N1 - 41	34
	N2 - 41	38
S21925001	N1 - 43	34
	N2 - 43	38
S21926001	N1 - 44	34
	N2 - 44	38
S21927001	N1 - 47	34
	N2 - 47	38
S21928001	N1 - 50	34
	N2 - 50	38
S21932001	N1 - 54	36
	N2 - 54	38
S21933001	N1 - 57	36
	N2 - 57	38
S21934001	N1 - 59	36
	N2 - 59	38
S21935001	N1 - 61	36
	N2 - 61	38
S21937001	N1 - 65	36
	N2 - 65	40
S21938001	N1 - 67	36
	N2 - 67	40
S21940101	N1 - 74	36
	N2 - 74	40
S21941001	M - 3	32
S21942001	Z2 - 26-2	48
S21943001	Z2 - 120	48
S21946101	Q - 1-1	44
S21947001	Q - 1-1-1	44
S21948101	Q - 1-1-2	44
S21949101	Q - 1-1-2-1	44
S21950009	Q - 1-1-3	44
S21951001	Q - 1-1-3-1	44
S21952101	Q - 1-2	44
S21953001	Q - 1-1-11	44
S21954001	Q - 1-1-15	44
S21955001	Q - 1-1-16	44
S21959001	A1 - 119	4
S21960001	A2 - 14-2	6
S21962001	J - 26	22
S21963001	K2 - 118	30
S21964001	P - 1	42
S21965001	P - 4	42
S21966001	P - 6	42
S21967001	P - 8	42
S21968001	P - 9	42
S21969001	P - 13	42
S21970001	P - 15	42
S21971001	P - 17	42
S21972001	P - 19	42
S21974001	P - 21	42
S21976001	P - 22	42

CODE	REF.NO.	Page
S21977001	P - 24	42
S21978000	P - 28	42
S21979001	P - 29	42
S21980001	P - 30	42
S21981001	P - 32	42
S21982101	P - 34	42
S21983001	P - 35	42
S21984001	P - 36	42
S21985001	P - 37	42
S21986001	P - 39	42
S21987001	P - 41	42
S21988001	P - 43	42
S23359001	E - 22	12
	E - 27	12
S23660000	L - 24	32
S24021000	L - 28	32
S25099001	Z2 - 29	48
S28438001	K1 - 138	26
	K2 - 138	30
S28468001	R - 2	46
S28469000	R - 3-2	46
S28596001	R - 1-1	46
S28597000	R - 1-3	46
S28598000	R - 1-3-1	46
S28599000	R - 1-3-2	46
	N2 - 81-2	40
S28600001	R - 1-5	46
S28670000	N2 - 81	40
S28671000	N2 - 81-1	40
S28674000	N2 - 85	40
S28675000	N2 - 86	40
S28676000	N2 - 86-1	40
S28677000	N2 - 88	40
S28678001	N2 - 80	40
S28680001	R - 7-1-1	46
S28681001	R - 1	46
S28682001	R - 7	46
S28683001	R - 7-1	46
S28685000	R - 7-3	46
S28686000	R - 7-4	46
S28744000	L - 26	32
S28759001	N1 - 63	36
	N2 - 63	40
S28760001	N1 - 71	36
	N2 - 71	40
S28798001	D - 32-1	10
S28800001	D - 32-2	10
S28801001	D - 32-3	10
S28821000	Q - 1-1-2-5	44
S28897001	L - 20	32
S28898001	L - 21	32
S28899001	L - 23	32
S28902000	L - 27	32
S29854009	Z2 - 90	50
S29855009	Z3 - 91	52
S30086001	C - 16-4	8
S30564000	K1 - 17	24
	K2 - 17	28
S30565001	K1 - 26	24
	K2 - 26	28
S30565002	K1 - 23	24
	K2 - 23	28
S30565003	K1 - 21	24
	K2 - 21	28
	K2 - 25	28

CODE	REF.NO.	Page
S30565004	K1 - 22	24
	K2 - 22	28
S31012001	D - 19	10
S31013001	D - 20	10
0A1501406	Z2 - 90-7-5	50
	Z3 - 91-8-5	52
	Z3 - 91-9-5	52
0A1503006	Z2 - 90-7-4	50
	Z2 - 90-12-2	50
	Z3 - 91-8-4	52
	Z3 - 91-9-4	52
	Z3 - 91-16-2	52
014060632	Z2 - 90-16	50
	Z3 - 91-20	52
014680422	C - 54	8
	G - 13	18
	J - 23	22
	P - 5	42
	P - 12	42
	P - 20	42
	K1 - 5	24
	K1 - 71	24
	K1 - 117	26
	K1 - 126	26
	K1 - 130	26
	K2 - 5	28
	K2 - 71	28
	K2 - 117	30
	K2 - 126	30
	K2 - 130	30
014680622	C - 43	8
	C - 45	8
	G - 17	18
	H - 17	20
	J - 1-1-1	22
	M - 4	32
014710522	Q - 1-1-17	44
014760622	C - 15	8
	C - 18	8
	D - 26	10
	N1 - 8	34
	N2 - 8	38
014770622	C - 2	8
	C - 5	8
	C - 7	8
	C - 13	8
	C - 50-1	8
	E - 46-1	14
	F - 9	16
	F - 12	16
	F - 15	16
	G - 20	18
	G - 24-1	18
	H - 2	20
	J - 13-1	22
	J - 16	22
	K1 - 45-1-1	24
	K2 - 45-1-1	28
	N1 - 12	34
	N2 - 12	38
014780622	E - 43	14
	F - 2	16
017711612	D - 15	10
017781412	E - 65	14
	H - 4	20

索引/INDEX/VERZEICHIS/
INDEX/INDICE

CODE	REF.NO.	Page
018060822	A1 - 13	2
018061222	R - 1-2	46
018061631	Q - 1-1-7	44
018062022	N1 - 4	34
	N2 - 4	38
018081622	A1 - 140	4
018300622	P - 31	42
018400832	Q - 1-1-4	44
018401422	P - 25	42
	K1 - 45-2-1	24
	K2 - 45-2-1	28
018501022	P - 16	42
018501222	N1 - 5	34
018505022	R - 1-4	46
018680822	P - 18	42
	K1 - 97	26
	K2 - 97	30
018681022	C - 36	8
	C - 52	8
	L - 5	32
	N1 - 28	34
	N2 - 28	38
018681032	L - 22	32
018771432	D - 10	10
	E - 7	12
	E - 48	14
	E - 52-2	14
	E - 55-1	14
	F - 7	16
	G - 2	18
	G - 11	18
	J - 5	22
	K1 - 47	24
	K1 - 55	24
	K2 - 47	28
	K2 - 55	28
021080106	Q - 1-3	44
	Z2 - 34	48
	Z2 - 106-6	50
021080302	Q - 1-1-2-3	44
	Q - 1-1-10	44
	Q - 1-7	44
	R - 1-6	46
	N1 - 1-4	34
	N2 - 84	40
021400102	P - 27	42
021400106	Z2 - 23	48
021500106	Z2 - 90-4-2	50
	Z2 - 90-7-3	50
	Z2 - 90-12-3	50
	Z2 - 125	48
	Z3 - 91-4-2	52
	Z3 - 91-8-3	52
	Z3 - 91-9-3	52
	Z3 - 91-13-3	52
	Z3 - 91-16-3	52
025030335	M - 1-4	32
025050236	Z2 - 123	48
025080232	Q - 1-1-2-4	44
	N1 - 1-6	34
025080236	Q - 1-5	44
	Z2 - 32	48
025080336	Z2 - 106-4	50
025350236	N1 - 55	36
	N2 - 55	38

CODE	REF.NO.	Page
025350332	H - 3-2	20
025770232	E - 64	14
028050246	Z2 - 90-7-2	50
	Z2 - 124	48
	Z3 - 91-8-2	52
	Z3 - 91-9-2	52
028080242	Q - 1-4	44
	Z2 - 33	48
	Z2 - 106-5	50
031452206	Z3 - 91-13-4	52
032422505	R - 7-2	46
032461606	Z2 - 106-7	50
047200642	B - 1-2	6
047201640	B - 7-1	6
047502242	E - 61	14
048020342	D - 40-1-5	10
	D - 40-2-5	10
048030342	K1 - 123	26
	K2 - 123	30
048040342	E - 9	12
	Q - 1-1-13	44
048050342	P - 3	42
048150143	E - 1-12	12
060630312	C - 56	8
060660416	K1 - 112	26
	K2 - 112	30
060670512	L - 15	32
060670612	N1 - 48	34
	N2 - 48	38
060680512	E - 76	14
	P - 42	42
	K1 - 121	26
	K2 - 119	30
	K2 - 121	30
	N1 - 72	36
	N2 - 72	40
060680712	D - 5	10
	A1 - 106	2
	K1 - 41	24
	K1 - 95	24
	K2 - 41	28
	K2 - 62	28
	K2 - 79	30
	K2 - 95	30
	N1 - 46	34
	N1 - 58	36
	N1 - 62	36
	N1 - 64	36
	N2 - 46	38
	N2 - 58	38
	N2 - 62	40
	N2 - 64	40
	Z2 - 37	48
060681612	A1 - 45	2
062020805	N1 - 60	36
	N2 - 60	38
062301616	N1 - 66	36
	N2 - 66	40
062303012	N2 - 87	40
062401406	Z2 - 24	48
062501006	Z2 - 122	48
	Z3 - 91-13-2	52
062501406	Z2 - 90-4-1	50
	Z3 - 91-4-1	52
062630412	L - 13	32

CODE	REF.NO.	Page
062630412	P - 33	42
	K1 - 88	24
	K2 - 88	30
062630612	G - 30	18
062660412	G - 4	18
062660512	D - 40-1-7	10
	D - 40-2-7	10
	E - 1-8	12
	P - 38	42
062660712	E - 52-1	14
062670512	K1 - 99	26
	K1 - 109	26
	K1 - 132	26
	K2 - 99	30
	K2 - 109	30
	K2 - 132	30
062670612	C - 21	8
	H - 8	20
	H - 10	20
	H - 14	20
	H - 20	20
	H - 23	20
	H - 41	20
	H - 51	20
	Q - 1-1-3-3	44
	Q - 1-1-6	44
	Q - 1-1-9	44
	A1 - 136	4
	K1 - 69	24
	K2 - 69	28
062670812	B - 5	6
	B - 8	6
	D - 33	10
	E - 19	12
	F - 25	16
	H - 3-3	20
	L - 11	32
062671012	H - 3-8	20
	Q - 1-1-3-2	44
062680512	P - 7	42
	N1 - 7	34
	N2 - 7	38
062680612	F - 4	16
	P - 23	42
	A1 - 47	2
	K1 - 92	24
	K2 - 44	28
	K2 - 92	30
062680663	Q - 1-1-3-5	44
	N1 - 70	36
	N2 - 70	40
062680712	L - 17	32
	L - 30	32
	P - 45	42
	N1 - 76	36
	N2 - 76	40
062680812	C - 37	8
	H - 33	20
	H - 43	20
	A1 - 28	2
	A1 - 101	2
	K1 - 2	24
	K1 - 74	24
	K2 - 2	28
	K2 - 74	28

索引/INDEX/VERZEICHIS/
INDEX/INDICE

CODE	REF.NO.	Page
062681012	E - 31	12
	E - 35	12
	J - 27	22
	A1 - 4	2
	A1 - 111	2
	A2 - 146	6
	K1 - 7	24
	K1 - 58	24
	K2 - 7	28
	K2 - 58	28
062681212	K1 - 32	24
	K2 - 32	28
062681412	D - 29	10
	J - 25	22
	A1 - 51	2
062681612	A1 - 16-1	2
	A2 - 16-2	6
062710812	A2 - 157	6
	A2 - 161	6
	Z2 - 57	48
062711012	C - 10	8
062711212	M - 2	32
062780812	H - 46	20
072600000	F - 22	16
076000600	M - 1-3	32
081003670	E - 12	12
081007670	J - 21	22
081014670	A1 - 6	2
081032870	F - 18	16
081044070	H - 36	20
100025002	E - 1-17	12
100032004	A1 - 32	2
100064005	C - 16-4-1	8
	D - 40-1-2	10
	D - 40-2-2	10
100251001	E - 5	12
100294002	E - 59	14
100644005	L - 2	32
	K1 - 135	26
	K2 - 135	30
100645003	E - 30	12
	H - 44	20
	P - 26	42
	K1 - 59	24
100666002	Z2 - 106-3	50
101118001	R - 4	46
101482001	J - 3	22
101572101	Z2 - 4	48
101706001	E - 40	12
	A1 - 104-1	2
102424004	Z2 - 44	48
102630001	C - 22	8
	Q - 1-1-14	44
102836004	P - 40	42
102843004	A1 - 20	2
	A1 - 37	2
103810002	K1 - 137	26
	K2 - 137	30
104449009	A1 - 21	2
104450109	A1 - 22	2
	A1 - 130	4
104464001	C - 12	8
104521002	N1 - 11	34
	N2 - 11	38
105161004	K1 - 110	26

CODE	REF.NO.	Page
105161004	K2 - 110	30
105234003	A1 - 52	2
	A1 - 112	2
105237002	L - 7	32
105343001	Z2 - 13	48
105955002	N1 - 27	34
	N2 - 27	38
106568003	N1 - 38	34
	N2 - 38	38
107153001	C - 17	8
107231002	N1 - 24	34
	N2 - 24	38
107272002	E - 45	14
107407003	A1 - 109	2
	A1 - 117	4
	A1 - 121	4
107419002	N1 - 45	34
	N2 - 45	38
107779001	Z2 - 14	48
107780001	Z2 - 21	48
108520009	A1 - 25	2
109203001	E - 60	14
	A1 - 142	4
109763002	P - 11	42
110140001	N1 - 18	34
	N2 - 18	38
110161006	D - 16	10
	G - 27	18
	J - 8	22
110167001	R - 1-7	46
110168001	R - 1-8	46
110197001	J - 22	22
110641002	A1 - 141	4
110704001	G - 3	18
110793001	D - 7	10
110813001	K1 - 12	24
	K2 - 12	28
110832009	K1 - 14	24
	K2 - 14	28
112299001	Z2 - 130	48
112300001	Z2 - 129	48
112301001	Z2 - 131	48
112351001	H - 27	20
112359001	H - 30	20
	H - 38	20
112364001	H - 24	20
112467002	H - 3-11	20
112743001	H - 7	20
112754001	H - 53	20
113431002	E - 50	14
114294001	F - 21	16
114985001	A1 - 46	2
116016001	Z2 - 25	48
116662003	Z2 - 58	48
117143003	N1 - 21	34
	N1 - 42	34
	N1 - 53	36
	N2 - 21	38
	N2 - 42	38
	N2 - 53	38
117466000	Z2 - 18	48
117516001	A1 - 118	4
	A1 - 122	4
117517003	E - 1-16	12
117934009	A1 - 18	2

CODE	REF.NO.	Page
118064001	Z2 - 17	48
118735002	P - 10	42
118770001	H - 11	20
118837001	Z2 - 5	48
118853001	C - 14	8
	N1 - 9	34
	N2 - 9	38
120990001	G - 31-1-1	18
122991001	Z2 - 91	48
123185001	A1 - 39	2
126863001	Z2 - 90-10	50
	Z3 - 91-12	52
138843001	Z2 - 90-15	50
	Z3 - 91-19	52
140063001	A1 - 107	2
140165001	E - 1-3	12
140176001	E - 1-15	12
140205001	E - 47	14
140207001	E - 21	12
140209001	E - 23	12
140210001	E - 24	12
140217001	E - 28	12
140313001	G - 31-2	18
140326009	E - 4	12
140327001	E - 14	12
	G - 9	18
140407001	D - 22	10
140678000	R - 2-3	46
140759000	Z2 - 41	48
141183000	A1 - 103	2
141208001	D - 23	10
141728001	D - 21	10
142268001	Q - 1-1-8	44
142274009	A1 - 49	2
142359001	H - 5	20
142721001	Z2 - 8	48
142998101	Z2 - 90-13	50
142999101	Z3 - 91-17	52
143311001	F - 23	16
143312000	F - 24	16
143325001	D - 3	10
143522000	Q - 1-1-3-6	44
143564001	E - 49	14
143565001	E - 51	14
143566001	Z2 - 15	48
143602001	K1 - 42	24
	K2 - 42	28
144053001	E - 1-9	12
144055001	E - 1-10	12
144075001	N1 - 56	36
	N2 - 56	38
144103009	K1 - 15	24
	K2 - 15	28
144104001	K1 - 18	24
	K2 - 18	28
144110001	K1 - 19	24
	K2 - 19	28
144224001	Z2 - 42	48
144504001	K1 - 105	26
	K2 - 82	30
	K2 - 105	30
144505000	K1 - 106	26
	K2 - 83	30
	K2 - 106	30
144526001	K1 - 127	26

索引/INDEX/VERZEICHNIS/
INDEX/INDICE

CODE	REF.NO.	Page
144526001	K1 - 133	26
	K2 - 127	30
	K2 - 133	30
144619000	H - 3-1	20
144622001	H - 3-5	20
144875001	H - 3-9	20
144876001	H - 3-10	20
145277105	Z2 - 20	48
145446001	K1 - 16	24
	K2 - 16	28
145472001	D - 24	10
145663001	E - 1-2	12
145688000	C - 20	8
145737001	H - 21	20
146049001	Z2 - 7	48
146254001	Q - 1-6	44
146315000	A1 - 125	4
146401001	E - 1-4	12
146402001	E - 1-5	12
146403001	E - 1-6	12
146404001	E - 1-7	12
146427001	C - 30-1	8
	C - 30-1	8
	K2 - 86	30
146457001	A1 - 135	4
146522101	D - 4	10
146528102	E - 1	12
146529001	E - 1-11	12
146530001	E - 1-13	12
146531001	E - 1-14	12
146532001	E - 2	12
146533001	E - 6	12
146538001	E - 13	12
146539000	E - 15	12
146540000	E - 16	12
146544000	E - 20-2	12
146547000	E - 41	12
	J - 17	22
146548101	E - 42	12
146554001	E - 25	12
146555001	E - 26	12
146556001	E - 53	14
146559001	E - 57	14
146560101	E - 58	14
146563001	E - 63	14
146586009	A1 - 50	2
	A1 - 110	2
	A1 - 129	4
146624101	G - 18	18
146741000	E - 39	12
146924000	K1 - 96-1	26
	K2 - 96-1	30
146930001	K1 - 136	26
	K2 - 136	30
147318000	E - 3	12
147363000	H - 48	20
147527000	H - 3-7	20
147528100	H - 3-12	20
147529000	H - 3-13	20
147893009	Z2 - 22	48
147919001	Z2 - 35	48
148084001	A1 - 30	2
148196000	J - 11	22
148197000	J - 12	22
148425001	G - 1-1	18

CODE	REF.NO.	Page
148425001	G - 18-1	18
148834001	E - 54	14
	J - 15-3	22
	J - 18	22
148847001	G - 26	18
	J - 7	22
	A2 - 158	6
	A2 - 162	6
149247001	Z2 - 26-1	48
149547000	L - 16	32
	P - 44	42
150106003	Z2 - 90-4	50
	Z3 - 91-4	52
150145009	Z2 - 90-12	50
	Z3 - 91-16	52
150172003	Z2 - 90-3	50
	Z3 - 91-3	52
150174000	Z2 - 90-5	50
	Z3 - 91-5	52
150179002	Z2 - 90-7-1	50
	Z3 - 91-8-1	52
	Z3 - 91-9-1	52
150180001	Z2 - 90-8	50
	Z3 - 91-10	52
150182000	Z2 - 90-9	50
	Z3 - 91-11	52
150185009	Z2 - 90-12-1	50
	Z3 - 91-16-1	52
150188009	Z3 - 91-13-1	52
150191002	Z2 - 90-2-2	50
	Z3 - 91-2-2	52
150206002	Z2 - 90-2-1	50
	Z3 - 91-2-1	52
150335001	Z2 - 10	48
150644009	K2 - 3	28
150645009	K1 - 4	24
	K2 - 4	28
151059001	A1 - 137	4
151429001	H - 9	20
151927001	H - 52	20
153222001	N1 - 40	34
	N2 - 40	38
153484001	E - 11	12
153675001	A1 - 44	2
153734001	F - 3	16
154125001	Z2 - 2	48
154596000	D - 27	10
154841009	A1 - 23	2
	A2 - 24	6
154886001	F - 6	16
154943001	B - 7	6
154945001	B - 7-2	6
154956001	D - 9	10
154957001	D - 11	10
154965001	E - 70	14
	K1 - 101	26
	K1 - 103	26
	K2 - 101	30
	K2 - 103	30
155144001	E - 17	12
155145000	E - 18	12
155151000	E - 29	12
155162001	K1 - 56	24
	K2 - 56	28
155175001	E - 66	14

CODE	REF.NO.	Page
155176001	E - 67	14
155177100	E - 32	12
155178001	E - 33	12
155220000	D - 8	10
	K1 - 48	24
	K2 - 48	28
155282101	H - 29	20
155294100	H - 49	20
155295001	H - 50	20
155510001	K1 - 107	26
	K2 - 84	30
	K2 - 107	30
155539000	C - 47	8
	D - 13	10
	G - 6	18
	K1 - 53	24
	K2 - 53	28
156112003	Z2 - 90-1	50
	Z3 - 91-1	52
156309001	Z2 - 12	48
156887001	A2 - 29	6
156937001	A2 - 147	6
157840000	H - 15	20
159150009	A1 - 7	2
159476000	H - 25	20
	H - 28	20
	H - 31	20
	H - 39	20
159574101	K1 - 13	24
	K2 - 13	28
159874000	R - 7-1-3	46
	N2 - 86-4	40
159908001	N1 - 15	34
	N2 - 15	38
181969003	A1 - 104	2
183796201	Q - 1	44
211528001	M - 1-8	32
211964001	Z2 - 31	48
215082001	M - 1-13	32
215083001	M - 1-5	32
216410003	M - 1-15	32
216870001	M - 1-12	32
219558000	M - 1-6-2	32
220077001	Q - 1-1-3-7	44
226391001	M - 1-16	32
230100001	M - 1-10	32
233193001	N1 - 73	36
	N2 - 73	40
234141001	M - 1-1	32
234143001	M - 1-2	32
234144001	M - 1-6	32
234145001	M - 1-6-1	32
234146001	M - 1-7	32
234153001	M - 1-11	32
234154002	M - 1-14	32
415006002	N2 - 82	40
525907000	N1 - 75	36
	N2 - 75	40
575456001	B - 2	6

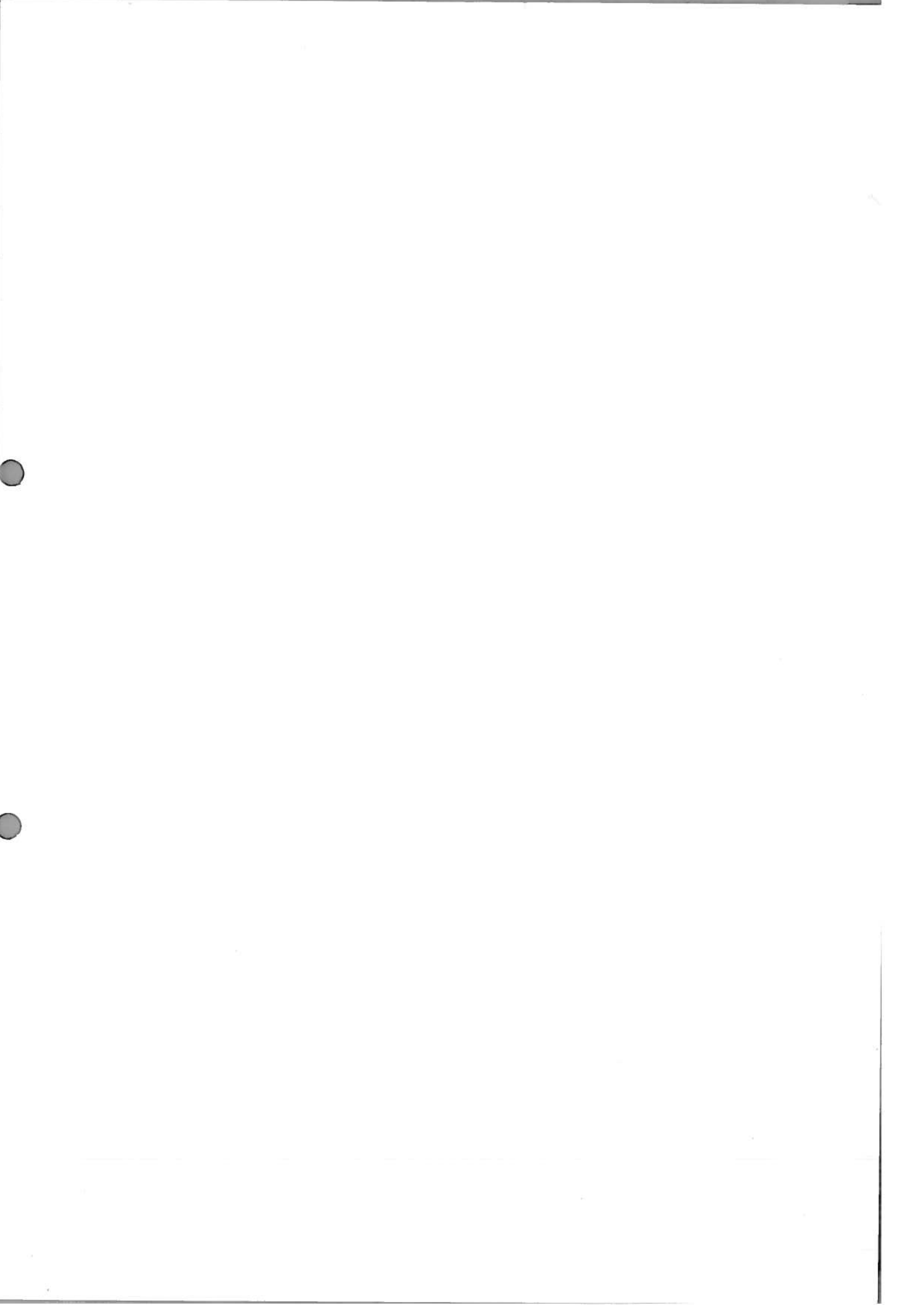

brother[®]

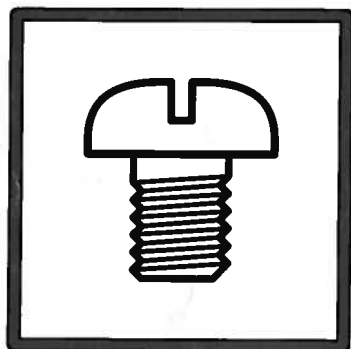

パーツブック
PARTS BOOK
TEILEKATALOG
LIVRE DES PIECES
LIBRO DE REFERENCIA DE PIEZAS

ブラザー工業株式会社
BROTHER INDUSTRIES, LTD.

〒467 名古屋市瑞穂区河岸1丁目1番1号 TEL(052)824-2392(代)

Printed in Japan/Gedruckt in Japan /Imprimé au Japon/Impreso en Japon

118-276-277
195276-101
1994, 03