

KE-430D  
BE-438D

パーツブック  
PARTS BOOK



---

本縫ダイレクトドライブ電子閉止ミシン  
本縫ダイレクトドライブ電子ボタン付けミシン

ELECTRONIC DIRECT DRIVE LOCKSTITCH BAR TACKER  
ELECTRONIC DIRECT DRIVE LOCKSTITCH BUTTON SEWER

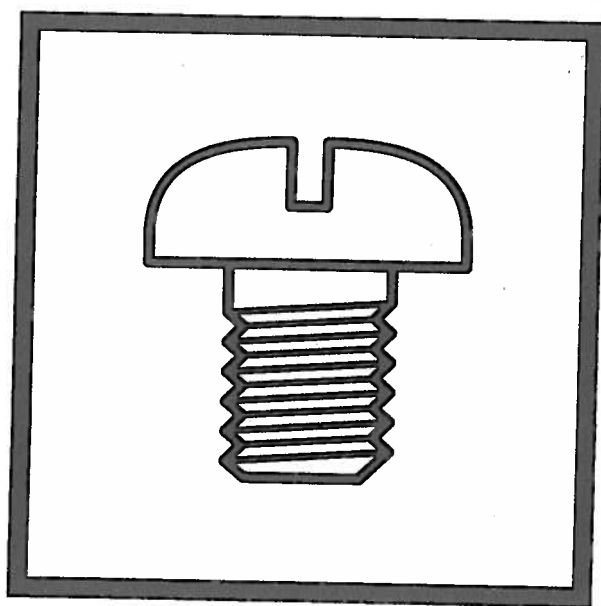

---

brother®

最新の部品情報は Parts Navigation でご覧いただけます。 <http://partsbook.brother.co.jp/partsnavi/jpn/>  
The latest parts information, refer to the Parts Navigation. <http://partsbook.brother.co.jp/partsnavi/eng/>

## パーツブックご利用に際して

1. この本は、2006年12月のデータに基づいて作成されたものです。
2. 部品は予告なしに設計変更される場合があります。
3. 組単位で補給する部品は、破線で示してあります。

### 目 次

A. 主体関係 .....	1
B. 上軸・針棒関係 .....	3
C. 送り関係 .....	5
D. 押え上げ関係 .....	9
E. ボタンつかみ・作動関係 .....	11
F. 下軸関係 .....	13
G. 給油潤滑関係 .....	15
H. 糸通し関係 .....	17
J. 糸巻関係 .....	19
K. 糸切り関係 .....	21
L. 糸払い関係 .....	25
M. 糸緩め関係 .....	27
N. 糸つかみ関係 .....	29
P1. コントロールボックス関係 .....	31
P2. コントロールボックス(電源基板)関係 .....	33
Q. スイッチ関係 .....	35
R. 電装品関係 .....	37
S. 操作パネル関係 .....	39
T. モータ関係 .....	41
U. 踏板関係 .....	43
V1. 補助装置関係	
(BE-438D用オプション部品) .....	45
V2. 補助装置関係	
(BE-438D用オプション部品) .....	47
Z. 付属品関係 .....	49
Sp. 仕様別部品一覧表 .....	53
Ga. ゲージ部品一覧表 .....	55
Wa. 警告ラベル .....	58
索引 .....	59

## Notes for using this parts book

1. This book was prepared based on information available in December 2006.
2. Parts are subject to changes in design without prior notice.
3. Parts supplied as complete assemblies are circled by a dotted line.

## CONTENTS

A. Machine body .....	1
B. Upper shaft and needle bar mechanism .....	3
C. Feed mechanism .....	5
D. Work clamp lifter mechanism .....	9
E. Button clamp mechanism .....	11
F. Lower shaft mechanism .....	13
G. Lubrication .....	15
H. Threading mechanism .....	17
J. Bobbin winder mechanism .....	19
K. Thread trimmer mechanism .....	21
L. Thread wiper mechanism .....	25
M. Tension release mechanism .....	27
N. Thread nipper mechanism .....	29
P1. Control box mechanism .....	31
P2. Control box (PCB) mechanism .....	33
Q. Power switch mechanism .....	35
R. Power supply equipment mechanism .....	37
S. Operation panel mechanism .....	39
T. Motor mechanism .....	41
U. Foot switch pedal mechanism .....	43
V1. Auxiliary device (Option parts for BE-438D ) .....	45
V2. Auxiliary device (Option parts for BE-438D ) .....	47
Z. Accessories .....	49
Sp. Different parts list .....	53
Ga. Gauge parts list .....	55
Wa. Warning labels .....	58
Index .....	59

A. 主体関係 / Machine body

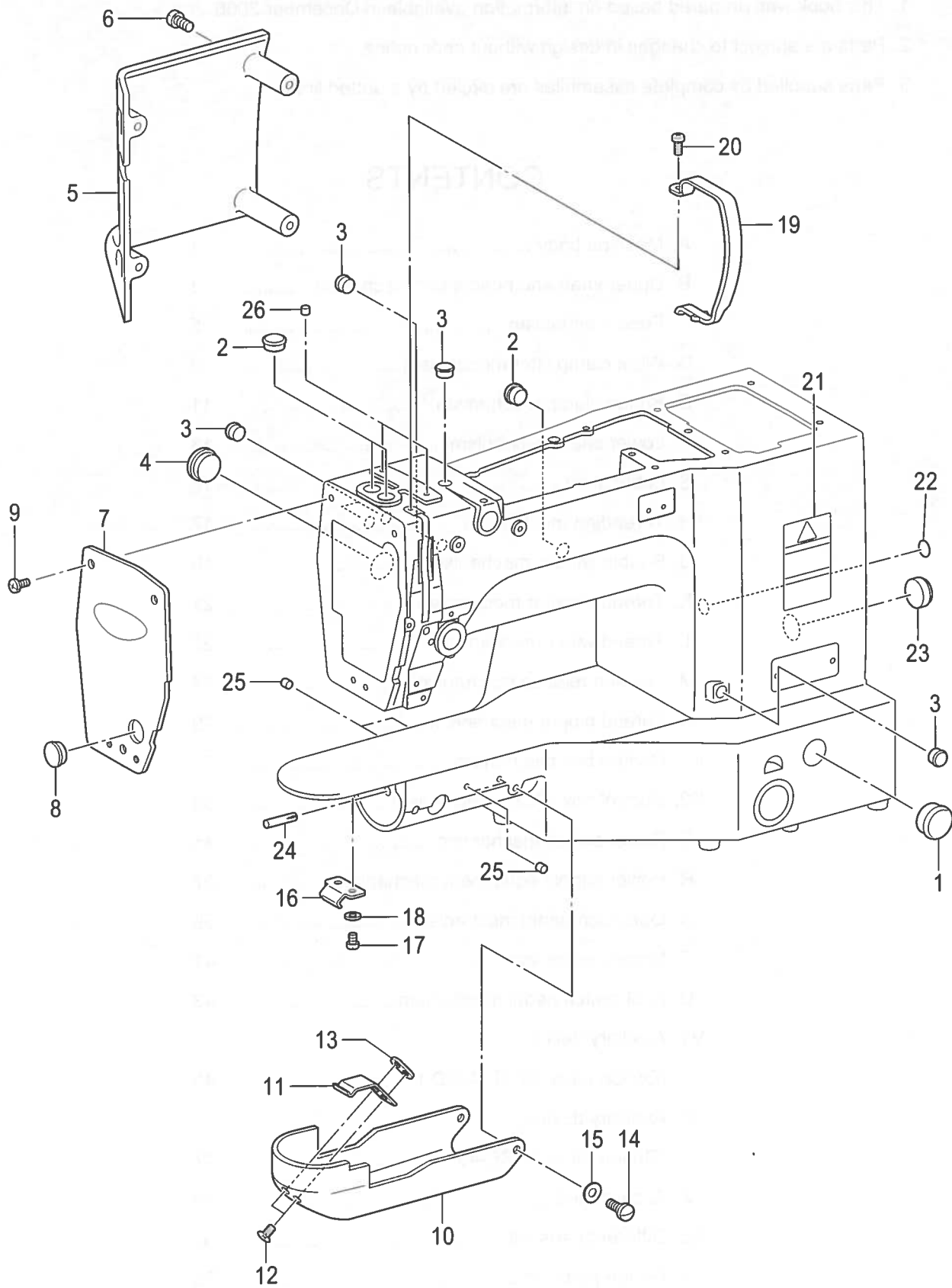

## A. 主体関係 / Machine body

REF.NO	CODE	Q'TY	品名	NAME OF PARTS	RM
1	140392009	1	オイルフタ	OIL CAP	
2	117934001	3	ゴムセン13.5	RUBBER CAP, 13.5	
3	104821001	5	ゴムセン10.5	RUBBER CAP, 10.5	
4	140392009	1	オイルフタ	OIL CAP	
5	SA3260001	1	ソクメンカバー	FRAME SIDE COVER	
6	062061016	4	ナベコ6X10	SCREW, PAN M6X10	
7	SA3199001	1	メンイタ	FACE PLATE	
8	104449001	1	ゴムセン15.5	RUBBER CAP, 15.5	
9	062501016	3	ナベコ5X10	SCREW, PAN M5X10	
10	SA3262101	1	オオカマカバー	SHUTTLE RACE COVER	
11	SA3263001	1	オオカマカバーフックD	SHUTTLE RACE COVER HOOK D	
12	004300513	2	+サラコ3X5	SCREW, FLAT M3X5	
13	SA3264001	1	イタナツト	NUT PLATE	
14	SA3265001	2	ダンネジ8-2	SHOULDER SCREW, 8-2	
15	109239002	2	ナミバネザガネ	WASHER, WAVE SPRING	
16	SA3266001	1	オオカマカバーフックU	SHUTTLE RACE COVER HOOK U	
17	062300416	2	ナベコ3X4	SCREW, PAN M3X4	
18	025030236	2	ヒラザガネチュウ3	WASHER, PLAIN M 3	
19	SA3200101	1	テンビンカバー	THREAD TAKE-UP COVER	
20	062401006	1	ナベコ4X10	SCREW, PAN M4X10	
			<中国向以外>	<Except for China>	
21	SA2040001	1	ラベルチュウイ.ワイ	LABEL, CAUTION JPN/ENG	
			<中国向>	<For China Only>	
21	SA2041001	1	ラベルチュウイ.チュウエイ	LABEL, CAUTION CHN/ENG	
22	S37060001	1	アースマーク	LABEL, GROUNDING	
23	S28044001	1	ゴムセン20.8	RUBBER CAP, 20.8	
24	117608001	1	ミゾツキピン	DOWEL PIN	
25	S20878000	4	ゴムセン5.3	RUBBER CAP, 5.3	
26	S20878000	2	ゴムセン5.3	RUBBER CAP, 5.3	

B. 上軸・針棒関係 / Upper shaft and needle bar mechanism

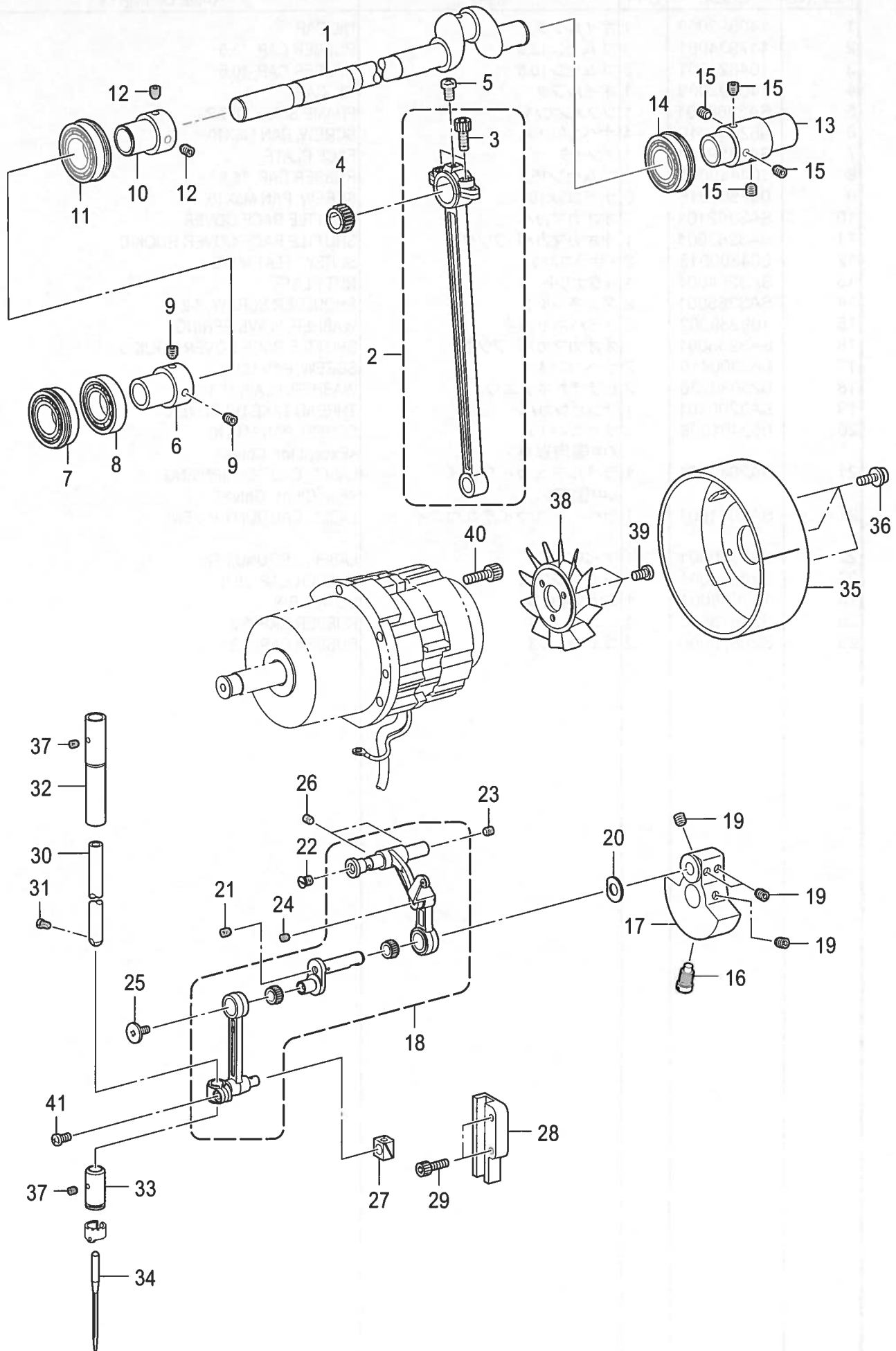

B. 上軸・針棒関係 / Upper shaft and needle bar mechanism

REF.NO	CODE	Q'TY	品名	NAME OF PARTS	RM
1	SA3201101	1	ウワジク	UPPER SHUFT	
2	SA3499001	1	クランクロッドクミ	CRANK ROD ASSY	
3	018501636	2	アナボルト5X16	BOLT, SOCKET M5X16	
4	SA4172001	1	ニードルベアリング	NEEDLE BEARING	
4	SA4173001	1	ニードルベアリング	NEEDLE BEARING	
4	SA4174001	1	ニードルベアリング	NEEDLE BEARING	
4	SA4175001	1	ニードルベアリング	NEEDLE BEARING	
5	062300416	1	ナベコ3X4	SCREW, PAN M3X4	
6	SA3206001	1	ベアリングブツシュ	BALL BEARING BUSH	
7	SA4179001	1	タマジクウケ6904DDUNR	BALL BEARINH, 6904DDUNR	
8	SA4180001	1	Rタマジクウケ6904DDU	BALL BEARING, RADIAL 6904DDU	
9	S23651001	2	アナヒラ6X6ホソメ	SET SCREW, SOCKET (FT) M6X6	
10	SA3206001	1	ベアリングブツシュ	BALL BEARING BUSH	
11	SA4177001	1	タマジクウケ6004DDUNR	BALL BEARING, 6004DDUNR	
12	S23651001	2	アナヒラ6X6ホソメ	SET SCREW, SOCKET (FT) M6X6	
13	SA3210001	1	<KE-430D用> ツギテA	<For KE-430D> JOINT, A	
13	SA3589001	1	<BE-438D用> ツギテB	<For BE-438D> JOINT, B	
14	SA4178001	1	タマジクウケ6204DDUNR	BALL BEARING 6204DDUNR	
15	S23651001	4	アナヒラ6X6ホソメ	SET SCREW, SOCKET (FT) M6X6	
16	S25235001	1	シメネジ8	SCREW, M8	
17	SA3497001	1	<KE-430D用> ツリアイクランクC	<For KE-430D> THREAD TAKE-UP CRANK, C	
18	SA6563001	1	ハリボウレンカンAクミ <BE-438D用>	THREAD TAKE-UP LEVER, A SET <For BE-438D>	
17	SA3591001	1	ツリアイクランクB	THREAD TAKE-UP CRANK, B	
18	SA4327001	1	ハリボウレンカンBクミ	THREAD TAKE-UP REVER, B SET	
19	S23651001	4	アナヒラ6X6ホソメ	SET SCREW, SOCKET (FT) M6X6	
20	110367001	1	ザガネ	WASHER, PLAIN SPECIAL 8	
21	012300336	1	アナヒラ3X3	SET SCREW, SOCKET (FT) M3X3	
22	SA2958001	1	サラネジ5X6	SCREW, FLAT M5X6	
23	012500536	1	アナヒラ5X5	SET SCREW, SOCKET (FT) M5X5	
24	012300336	1	アナヒラ3X3	SET SCREW, SOCKET (FT) M3X3	
25	145465001	1	シメネジ3.57L	SCREW, SM3.57-40X6 L	
26	012060636	2	アナヒラ6X6	SET SCREW, SOCKET (FT) M6X6	
27	SA3488001	1	カクコマ	SLIDE BLOCK	
28	SA3528001	1	カクコマアンナイB	SLIDE BLOCK GUIDE	
29	018401636	2	アナボルト4X16	BOLT, SOCKET M4X16	
30	SA3222001	1	ハリボウA	NEEDLE BAR, A	
31	144458001	1	アタマツキトメネジ3.57	SET SCREW, SM3.57-40X4.5	
32	SA3223001	1	ハリボウメタルU	NEEDLE BAR BUSH, U	
33	SA3224001	1	ハリボウメタルD	NEEDLE BAR BUSH, D	
34	* P. 54	1	ミシンハリ	NEEDLE	
35	SA3225101	1	プーリ	PULLEY	
36	SA3025001	3	ナベザクミ4X10DA	SCREW, PAN (S/P WASHER) M4X10	
37	012500536	2	アナヒラ5X5	SET SCREW, SOCKET (FT) M5X5	
38	S38713100	1	ファン	FAN	
39	062400806	3	ナベコ4X8	SCREW, PAN M4X8	
40	018501636	4	アナボルト5X16	BOLT, SOCKET M5X16	
41	062400816	1	ナベコ4X8	SCREW, PAN M4X8	

KE-430D/BE-438D-123

C. 送り関係 / Feed mechanism

< オプション部品 / Option parts >

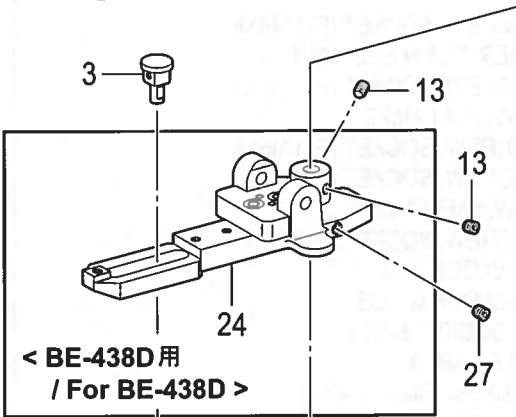
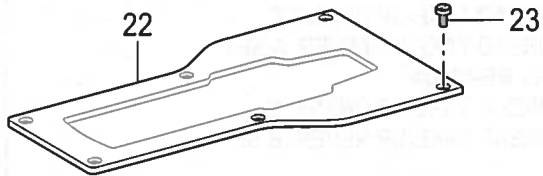
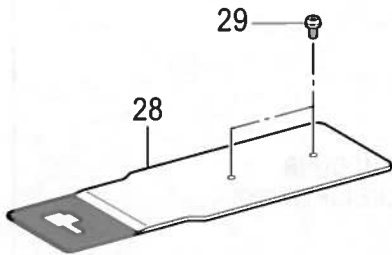
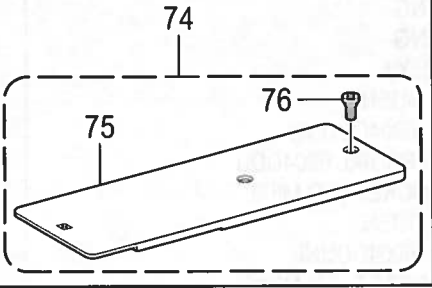

< BE-438D用 / For BE-438D >

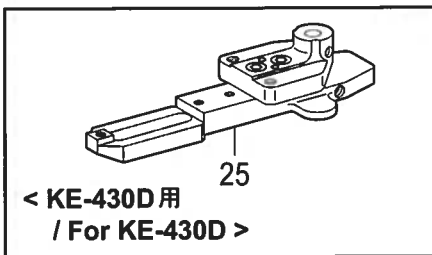
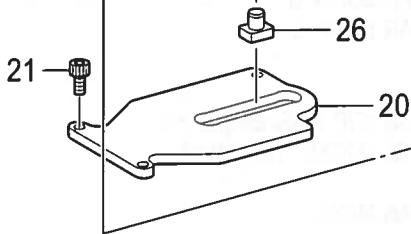

< KE-430D用 / For KE-430D >

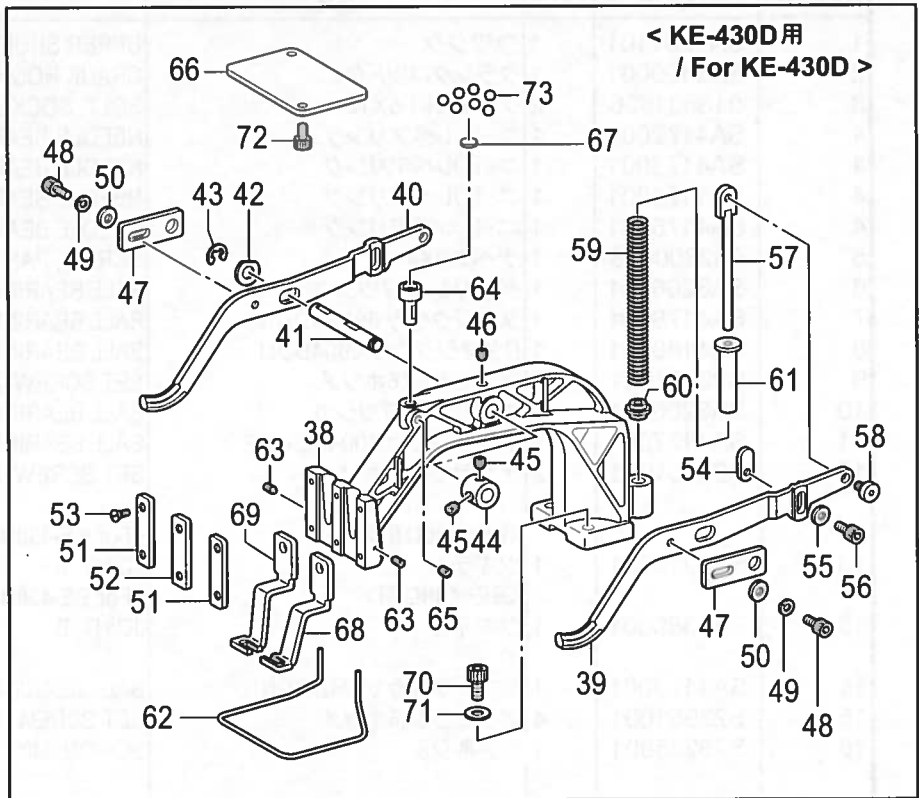

< KE-430D用 / For KE-430D >

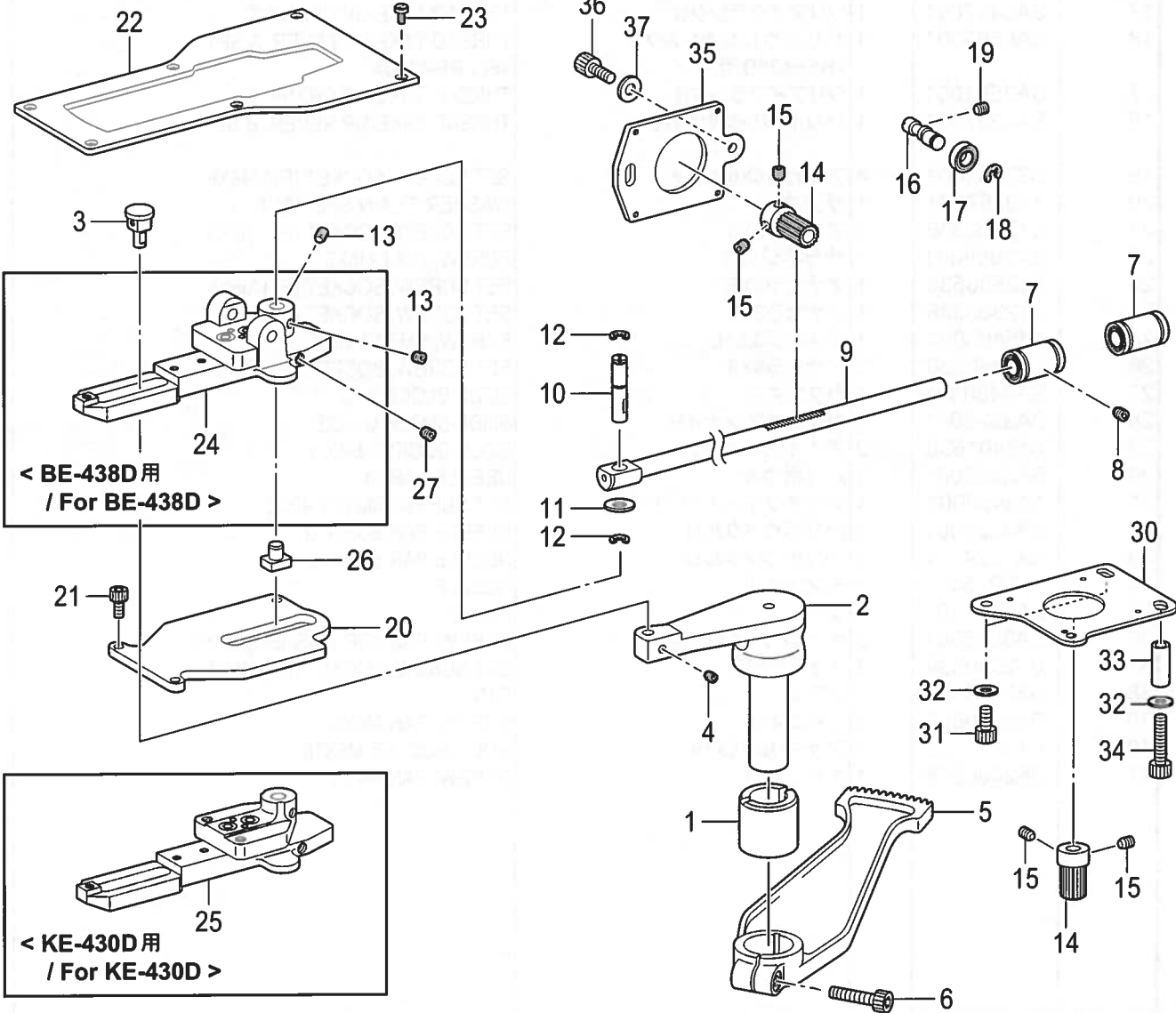



C. 送り関係 / Feed mechanism

REF.NO	CODE	QTY	品名	NAME OF PARTS	RM
1	SA3363001	1	Xオクリレバー-メタル	X-FEED LEVER BUSH	
2	SA3364001	1	Xオクリレバー	X-FEED LEVER	
3	SA3533001	1	Xオクリカクコマクミ	T-LENGTH REGURATOR BLOCK ASSY	
4	012500536	1	アナヒラ5X5	SET SCREW, SOCKET (FT) M5X5	
5	SA3366001	1	Xオクリギア	X-FEED GEAR	
6	018063036	1	アナボルト6X30	BOLT, SOCKET M6X30	
7	XC5780001	2	リニアブツシユ10	BEARING 10, LINER	
8	012060636	2	アナヒラ6X6	SET SCREW, SOCKET (FT) M6X6	
9	SA3367001	1	Yラックジク	Y-FEED RACK SHAFT	
10	SA3368001	1	Yラックピン	Y-CONNECTING PIN	
11	153113001	1	スラストザガネ	THRUST WASHER	
12	048060342	2	トメワE6	RETAINING RING, E6	
13	012060636	2	アナヒラ6X6	SET SCREW, SOCKET (FT) M6X6	
14	SA4197001	2	オクリギア	FEED GEAR	
15	012060636	4	アナヒラ6X6	SET SCREW, SOCKET (FT) M6X6	
16	SA3370001	1	ヘンシンジク	ECCENTRIC SHAFT	
17	070608800	2	Rタマジクウケ608ZZ	BALL BEARING, ARDIAL 608ZZ	
18	048080142	1	トメワジクヨウC8	RETAINING RING, EXTERNAL C8	
19	012060636	1	アナヒラ6X6	SET SCREW, SOCKET (FT) M6X6	
20	SA3371001	1	オクリダイウケイタ	FEED BAR SUPPORT PLATE	
21	018401036	3	アナボルト4X10	BOLT, SOCKET M4X10	
22	SA3372001	1	オクリダイカバー	FEED BAR COVER	
23	SA3538001	6	シメネジ4X8	SCREW, M4X8	
24	SA3604001	1	<BE-438D用> オクリダイコクミB	<For BE-438D> FEED BAR SUB ASSY B	
25	SA3373001	1	<KE-430D用> オクリダイコクミA	<For KE-430D> FEED BAR SUB ASSY A	
26	SA3534001	1	Y オクリカクコマクミ	T-WIDTH REGURATOR BROCK ASSY	
27	012060636	1	アナヒラ6X6	SET SCREW, SOCKET (FT) M6X6	
28	* P. 54-56	1	オクリイタ	FEED PLATE	
29	153057101	2	オクリイタシメネジ	SCREW, ROUND W/SOCKET SM4.37	
30	SA3381001	1	Xモーターリツケイタ	X-MOTOR SETTING PLATE	
31	018061236	2	アナボルト6X12	BOLT, SOCKET M6X12	
32	025060236	3	ヒラザガネチユウ6	WASHER, PLAIN M 6	
33	SA3708001	1	カラ-	COLLAR	
34	018063536	1	アナボルト6X35	BOLT, SOCKET M6X35	
35	SA3382001	1	Yモーターリツケイタ	Y-MOTOR SETTING PLATE	
36	018061236	2	アナボルト6X12	BOLT, SOCKET M6X12	
37	025060236	2	ヒラザガネチユウ6	WASHER, PLAIN M 6	
38	SA3419101	1	<KE-430D用> オサエウデ	<For KE-430D> WORK CLAMP ARM	
39	SA3420001	1	QCオサエウデレバーR	WORK CLAMP ARM LEVER, R	
40	SA3421001	1	QCオサエウデレバーL	WORK CLAMP ARM LEVER, L	
41	SA3422001	1	QCオサエウデレバージク	WORK CLAMP ARM LEVER SHAFT	
42	110367001	1	ザガネ	WASHER, PLAIN SPECIAL 8	
43	048060346	1	トメワE6	RETAINING RING, E6	
44	SA3231001	1	セツトカラ-B	SET SCREW COLLAR, B	
45	012060536	2	アナヒラ6X5	SET SCREW, SOCKET (FT) M6X5	
46	012500536	1	アナヒラ5X5	SET SCREW, SOCKET (FT) M5X5	
47	SA3423001	2	QCLレバージクササエ	WORK CLAMP LEVER SUPPORT	
48	018500836	2	アナボルト5X8	BOLT, SOCKET M5X8	
49	028050246	2	バネザガネ2-5	WASHER, SPRING 2-5	
50	025050236	2	ヒラザガネチユウ5	WASHER, PLAIN M 5	
51	SA3424001	2	オサエアシオサエイタA	WORK CLAMP GUIDE BRACKET, A	
52	SA3425001	1	オサエアシオサエイタB	WORK CLAMP GUIDE BRACKET, B	
53	SA3426001	6	オサエアシサラネジ3.5	SCREW, FLAT M3.5	
54	SA3208201	2	オサエウデレバーイタ	WORK CLAMP ARM LEVER PLATE	
55	146354002	2	ザガネ	WASHER, PLAIN 5	
56	018500836	2	アナボルト5X8	BOLT, SOCKET M5X8	
57	SA3427101	2	オサエバネアンナイロツド	SPRING GUIDE ROD	

KE-430D/BE-438D-202

C. 送り関係 / Feed mechanism

< オプション部品 / Option parts >

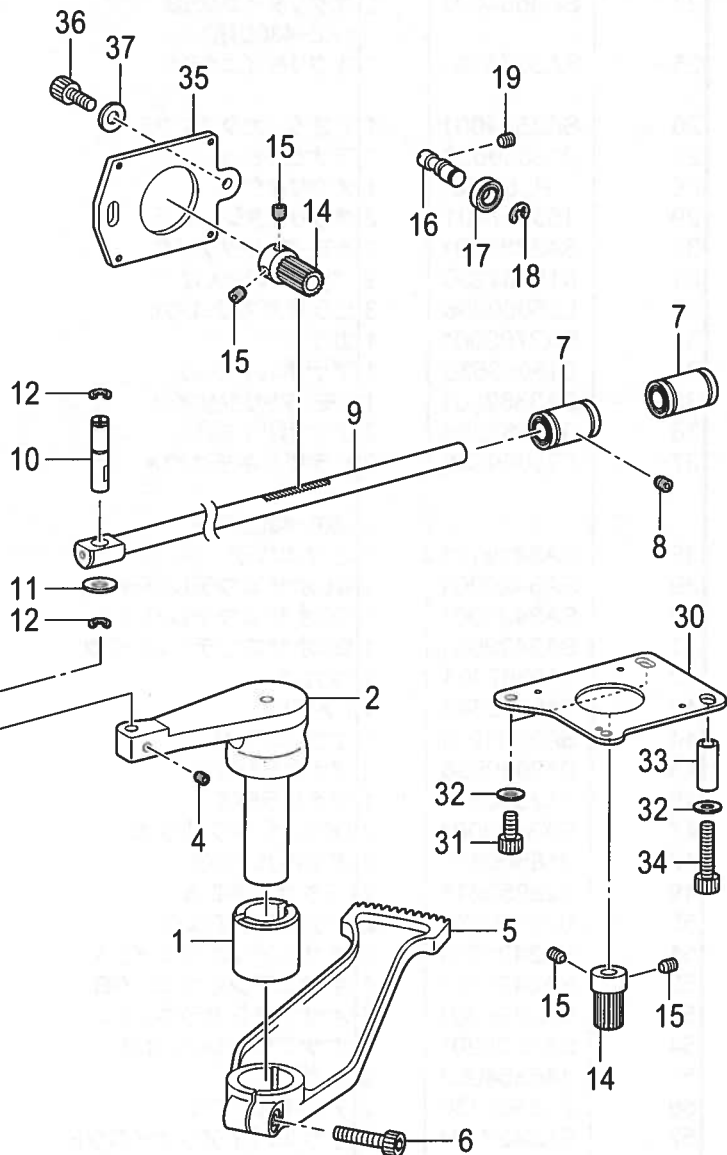
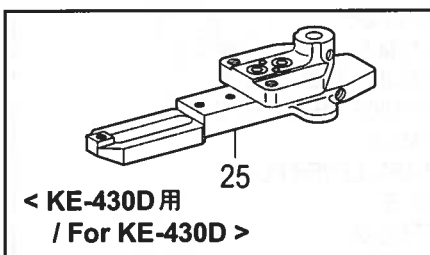
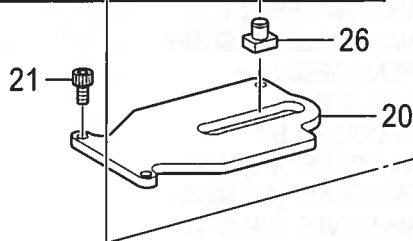
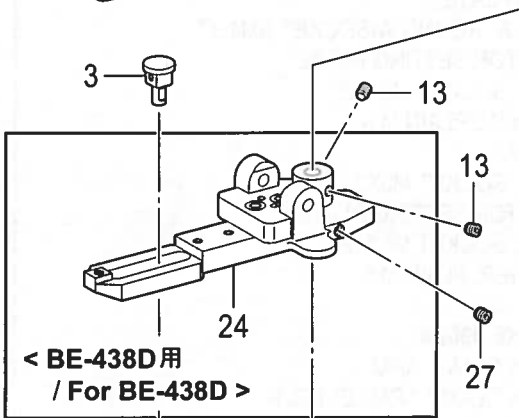
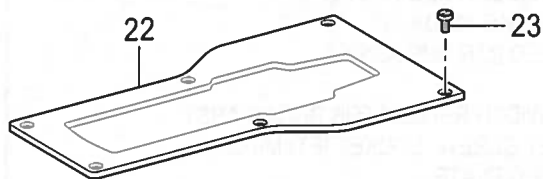
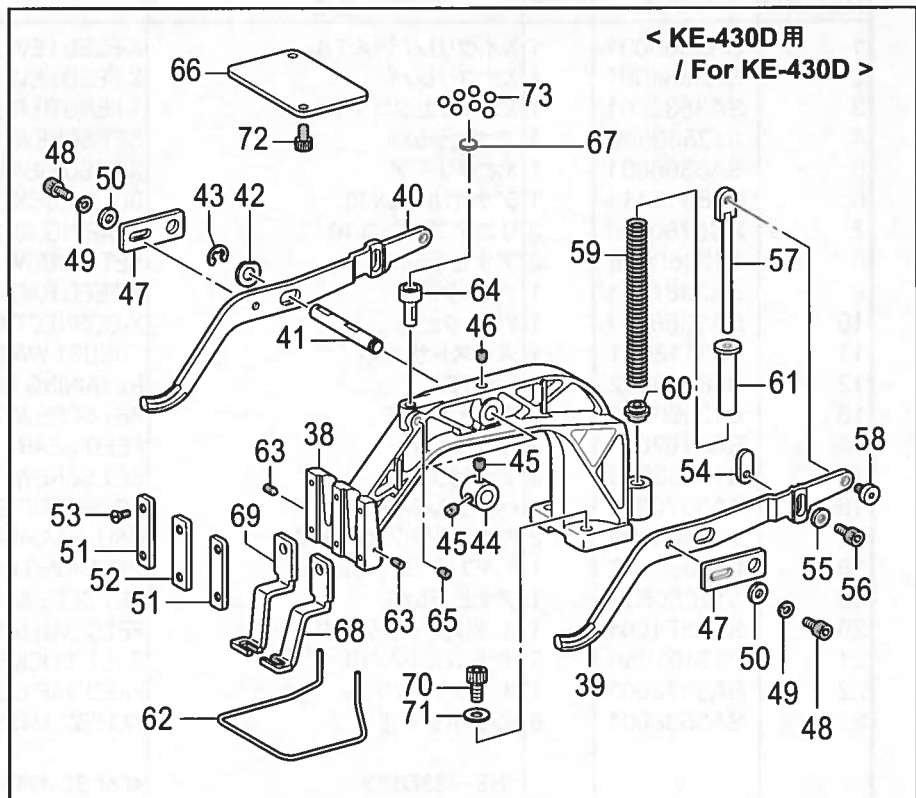
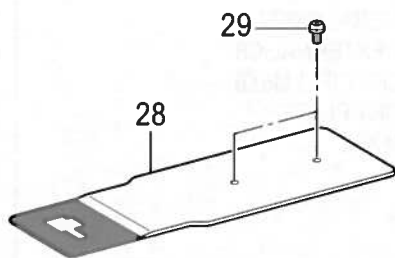
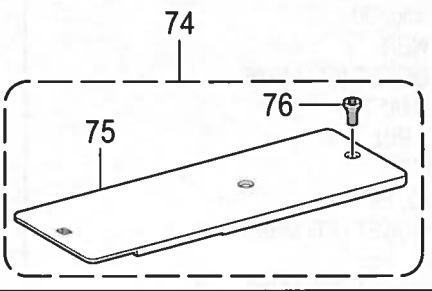

C. 送り関係 / Feed mechanism

REF.NO	CODE	Q'TY	品名	NAME OF PARTS	RM
			<KE-430D用>	<For KE-430D>	
58	SA1179002	2	ダンネジ5	SHOULDER SCREW, M5	
59	153568001	2	オサエバネA	PRESSER SPRING, A	
60	152788000	2	オサエバネカンザ	PRESSER SPRING SPACER	
61	153567000	2	オサエバネカラ-	PRESSER SPRING COLLAR	
62	SA4130001	1	フィンガーガード	FINGER GUARD	
63	SA2626001	2	トメネジ3.5	SET SCREW, (CP) M3.5	
64	SA3428001	1	オサエウデササエジク	SUPPORT SHAFT, W-CLAMP	
65	012500536	1	アナヒラ5X5	SET SCREW, SOCKET (FT) M5X5	
66	SA3487001	1	オサエウデササエイタ	WORK CLAMP ARM SUPPORT PLATE	
67	SA4145001	1	オサエウデカンザ	SPACER, W-CLAMP	
68	* P. 54-56	1	オサエアシR	WORK CLAMP, RIGHT	
69	* P. 54-56	1	オサエアシL	WORK CLAMP, LEFT	
70	018061636	2	アナボルト6X16	BOLT, SOCKET M6X16	
71	025060236	2	ヒラザガネチユウ6	WASHER, PLAIN M 6	
72	018400836	2	アナボルト4X8	BOLT, SOCKET M4X8	
73	071031840	7	コウキユウ1/8	BEARING BALL, 1/8	
			<オプション部品>	<Option parts>	
74	SA4198001	1	ゲンテンキジュンイタクミ	H-POSITION STSNDARD PLATE, ASSY	
75	S42903001	1	ゲンテンキジュンイタ	H-POSITION STSNDARD PLATE	
76	S49955101	2	オクリイタシメネジ	SCREW, W/SOCKET SM4.37	

D. 押え上げ関係 / Work clamp lifter mechanism

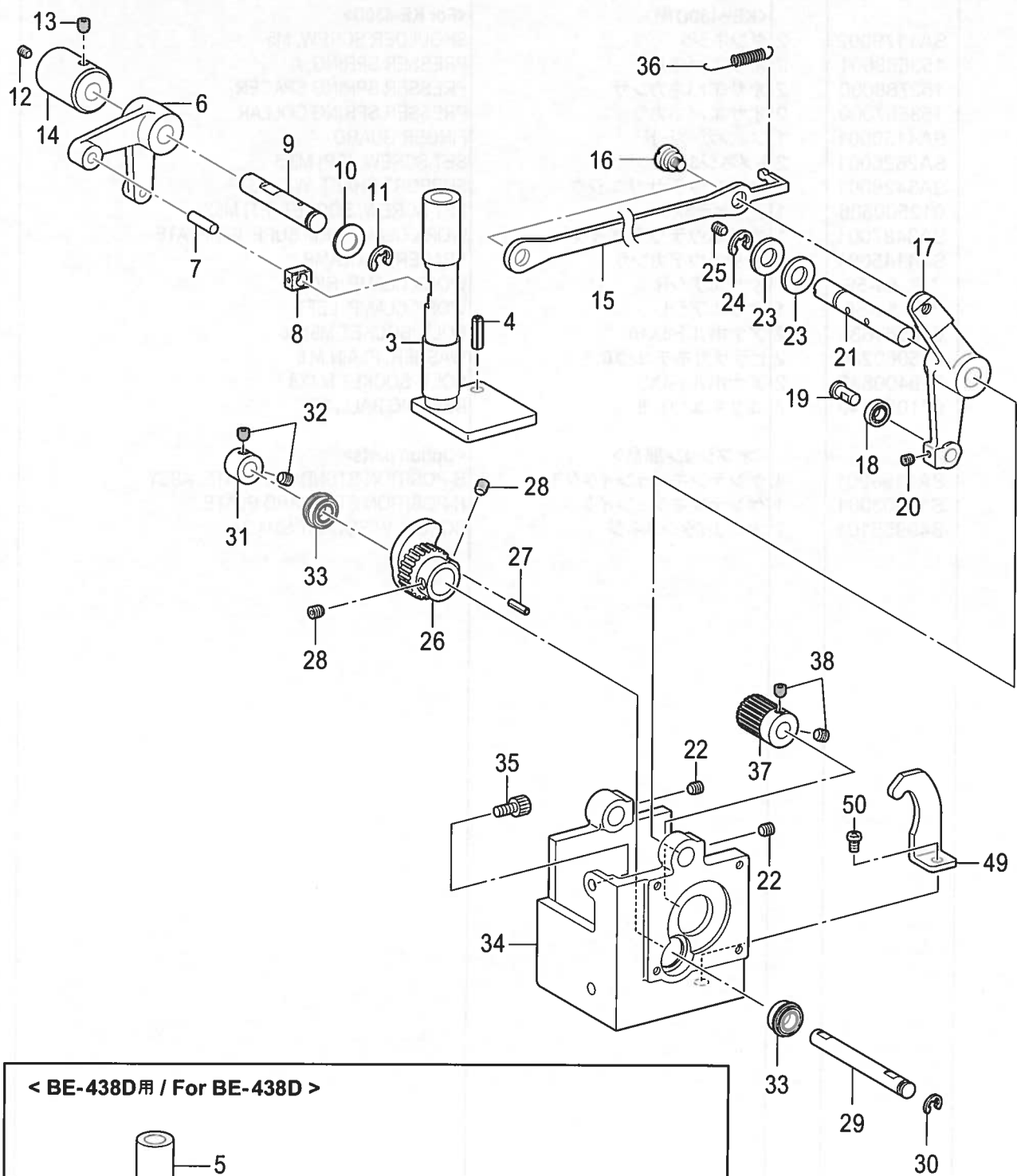

< BE-438D用 / For BE-438D >

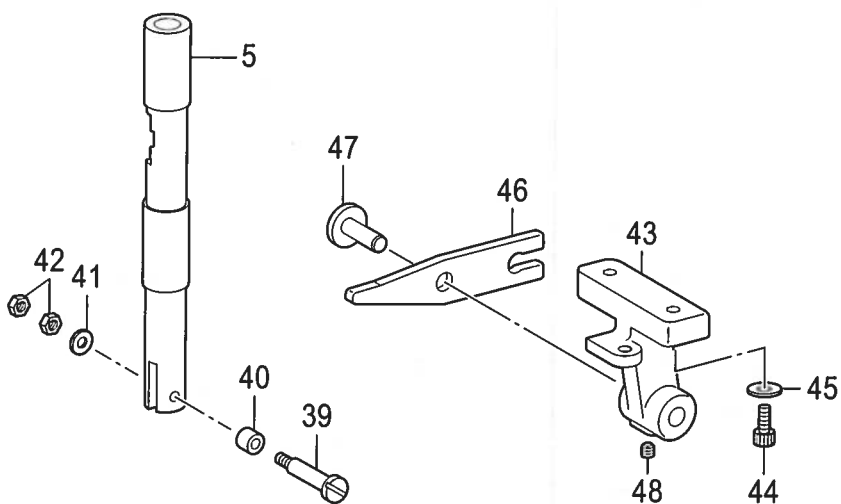

## D. 押え上げ関係 / Work clamp lifter mechanism

REF.NO	CODE	Q'TY	品名	NAME OF PARTS	RM
			<KE430D用>	<For KE-430D>	
3	SA3432001	1	オサエアゲオサエイタ	WORK CLAMP LIFTER PLATE	
4	047602042	1	スプリングピンAW6	PIN, SPRING ROLL AW6	
			<BE-438D用>	<For BE-438D>	
5	SA3628001	1	ボタンツカミロッド	BUTTON CLAMP ROD	
6	SA3434001	1	オサエアゲレバー	LIFTER LEVER	
7	152744001	1	ヨコオクリカクコマピン	PIN	
8	102630001	1	ハリボウアンナイカクコマ	NEEDLE BAR GUIDE SLIDE BLOCK	
9	SA3435001	1	オサエアゲレバージク	LEVER SHAFT	
10	S20356001	1	ヒラザガネ10	WASHER, PLAIN 10	
11	048080342	1	トメワE8	RETAINING RING, E8	
12	012500536	1	アナヒラ5X5	SET SCREW, SOCKET (FT) M5X5	
13	012060636	1	アナヒラ6X6	SET SCREW, SOCKET (FT) M6X6	
14	SA3436001	1	オサエアゲレバーメタル	W-CLAMP LIFTER LEVER BUSH	
15	SA3437001	1	オサエアゲリンク	LINK	
16	SA3438001	2	オサエアゲリンクダンネジ	LINK SHOULDER SCREW	
17	SA3439001	1	オサエアゲドウレバー	DRIVE LEVER W-CLAMP LIFTER	
18	070696800	1	Rタマジクウケ696ZZ	BALL BEARING, RADIAL 696ZZ	
19	SA3441001	1	オサエアゲコロジク	W-CLAMP LIFTER ROLLER SHAFT	
20	012500536	1	アナヒラ5X5	SET SCREW, SOCKET (FT) M5X5	
21	SA3442001	1	オサエアゲカムレバージク	CAM LEVER SHAFT	
22	012060636	2	アナヒラ6X6	SET SCREW, SOCKET (FT) M6X6	
23	S20356001	2	ヒラザガネ10	WASHER, PLAIN 10	
24	048080342	1	トメワE8	RETAINING RING, E8	
25	012500536	1	アナヒラ5X5	SET SCREW, SOCKET (FT) M5X5	
26	SA3443101	1	オサエアゲカムギヤ	CAM GEAR	
27	047301042	1	スプリングピンAW3	PIN, SPRING ROLL AW3	
28	012060636	2	アナヒラ6X6	SET SCREW, SOCKET (FT) M6X6	
29	SA3444001	1	オサエアゲカムジク	CAM SHAFT	
30	048060346	1	トメワE6	RETAINING RING, E6	
31	SA3231001	1	セットカラ-B	SET SCREW COLLAR, B	
32	012060536	2	アナヒラ6X5	SET SCREW, SOCKET (FT) M6X5	
33	070688850	2	Rタマジクウケ688ZZ	BALL BEARING, RADIAL 688ZZ	
34	SA3445001	1	モータブラケット	MOTOR BRACKET	
35	018061236	2	アナボルト6X12	BOLT, SOCKET M6X12	
36	SA3446001	1	オサエアゲバネ	SPRING	
37	SA3707001	1	クドウギヤ16	GEAR 16	
38	012060536	2	アナヒラ6X5	SET SCREW, SOCKET (FT) M6X5	
			<BE-438D用>	<For BE-438D>	
39	SA3629001	1	ボタンツカミコロジク	BUTTON CLAMP ROLLER SHAFT	
40	107744001	1	コロ	ROLLER	
41	025040236	1	ヒラザガネチユウ4	WASHER, PLAIN M 4	
42	021400216	2	2シュナツト4	NUT, 2 M4	
43	SA3630001	1	ボタンツカミレバーホルダ	BUTTON CLAMP LEVER HOLDER	
44	018061636	2	アナボルト6X16	BOLT, SOCKET M6X16	
45	025060236	2	ヒラザガネチユウ6	WASHER, PLAIN M 6	
46	SA3631001	1	ボタンツカミレバー	BUTTON CLAMP LEVER	
47	153838001	1	ボタンツカミレバジク	BUTTON CLAMP LEVER SHAFT	
48	012060636	1	アナヒラ6X6	SET SCREW, SOCKET (FT) M6X6	
49	SA4072001	1	オサエアゲカムストッパ	STOPPER	
50	062061016	1	ナベコ6X10	SCREW, PAN M6X10	

E. ボタンつかみ・作動関係 / Button clamp mechanism

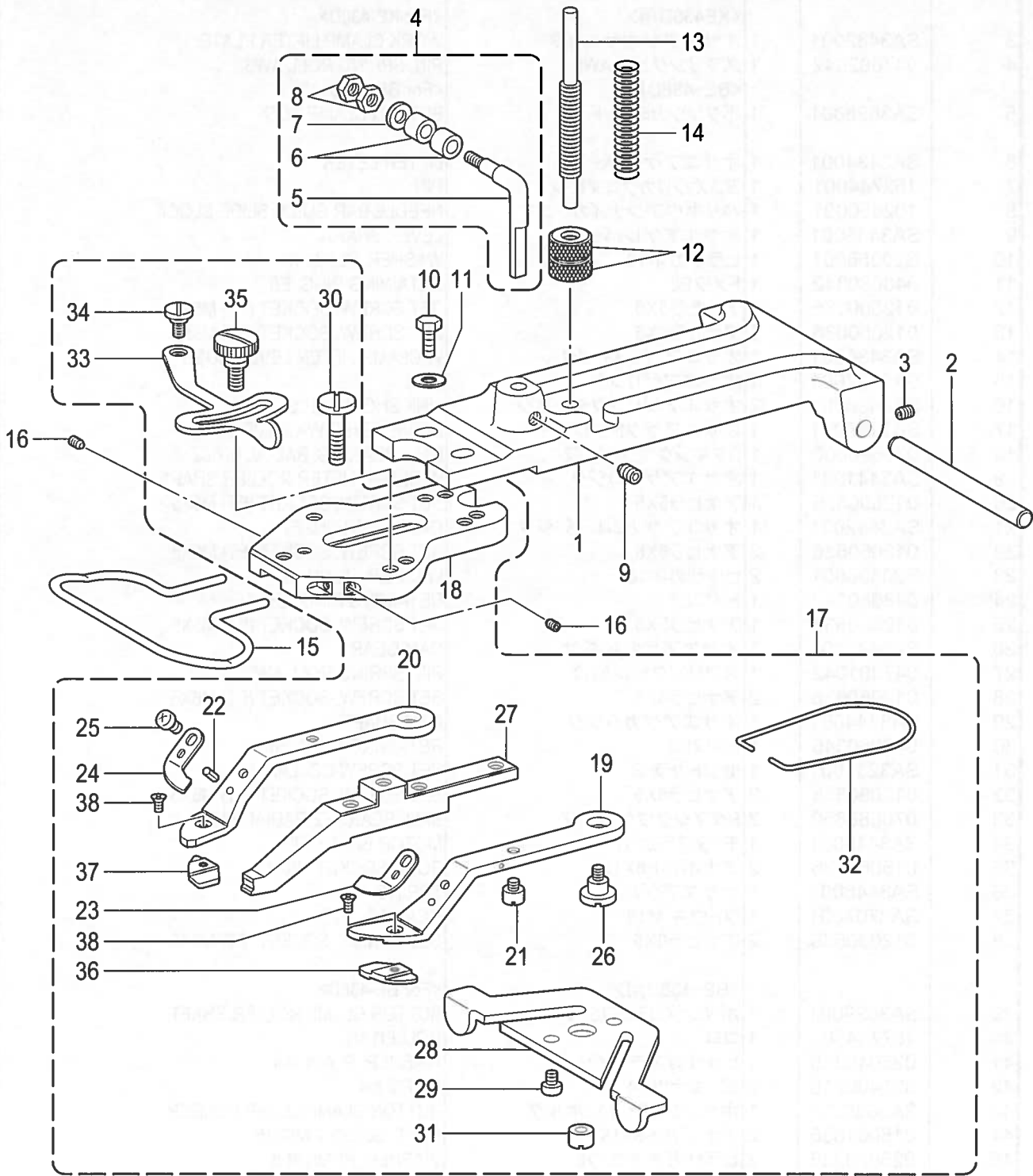

< オプション部品 / Option parts >



## E. ボタンつかみ・作動関係 / Button clamp mechanism

REF.NO	CODE	Q'TY	品名	NAME OF PARTS	RM
			<BE-438D用>	<For BE-438D>	
1	153830000	1	ボタンツカミホルダ-	BUTTON CLAMP HOLDER	
2	153827001	1	ボタンツカミホルダ-ジク	BUTTON CLAMP HOLDER SHAFT	
3	014680632	2	アナクボミ437-40X6	SET SCREW, SOCKET SM4.37-40X6	
4	151968001	1	ボタンホルダ-フツクミ	BUTTON CLAMP HOLDER HOOK ASSY	
5	151969001	1	ボタンホルダ-フツク	B-CLAMP HOLDER HOOK	
6	107744001	2	コロ	ROLLER	
7	153484001	1	ザガネ4.76	WASHER, PLAIN 4.76	
8	105234003	2	ナット4.37	NUT SM4.37	
9	014760632	1	アナクボミ595-28X6	SET SCREW, SOCKET SM5.95-28X6	
10	017711412	2	ボルト476-32X14	BOLT, SM4.76-32X14	
11	146354001	2	ザガネ	WASHER, PLAIN 5	
12	146994001	2	オサエバネチヨウシネジ	NUT, ROUND SM6.35-40	
13	115148201	1	オサエバネチヨウセツネジ	ADJUSTING SCREW, SM6.35-40	
14	115147001	1	ボタンツカミオサエオシバネ	COMPRESSION SPRING	
15	S49998001	1	フィンガーガード	FINGER GUARD	
16	011679312	2	トメネジ3.57ヒラ	SET SCREW, (FT) SM3.57	
17	S59315001	1	ボタンツカミ2Aクミ	BUTTON CLAMP ASSY, 2A	
18	S52093001	1	ボタンツカミタイ	BUTTON CLAMP BASE	
19	S59316001	1	ボタンツカミ2AL	BUTTON CLAMP, 2AL	
20	S59317001	1	ボタンツカミ2AR	BUTTON CLAMP, 2AR	
21	115156001	2	ボタンツカミアンナイピン	BUTTON CLAMP GUIDE PIN	
22	047250642	2	スプリングピンAW2.5	PIN, SPRING ROLL AW2.5	
23	S59318001	1	ボタンツカミ2ALイタバネ	BUTTON CLAMP 2AL PLATE SPRING	
24	S59319001	1	ボタンツカミ2ARイタバネ	BUTTON CLAMP 2AR PLATE SPRING	
25	062680512	2	ナベコ437-40X5	SCREW, PAN SM4.37-40X5	
26	115158001	2	ダンネジ4.76	SHOULDER SCREW, SM4.76	
27	S59320001	1	ボタンツカミ2AM	BUTTON CLAMP, 2AM	
28	S03659001	1	ボタンツカミイタカム	BUTTON CLAMP PLATE CAM	
29	062680812	2	ナベコ437-40X8	SCREW, PAN SM4.37-40X8	
30	S03468101	1	シメネジ4.37	SCREW, SM4.37	
31	S03657001	1	マルナット4.37	NUT, ROUND SM4.37	
32	S59321001	1	ボタンツカミバネ	SPRING	
33	115164101	1	ボタンツカミチヨウセツイタ	BUTTON CLAMP ADJUSTING PLATE	
34	115165001	1	ダンネジ4.37	SHOULDER SCREW, SM4.37	
35	115166001	1	ダンネジ4.37	SHOULDER SCREW, SM4.37	
36	S52072001	1	ボタンツカミスペーサBL	BUTTON CLAMP SPACER, BL	
37	S52076001	1	ボタンツカミスペーサBR	BUTTON CLAMP SPACER, BR	
38	S01694001	2	サラネジ2.38X4	SCREW, FLAT SM2.38X4	
			<オプション部品>	<Option parts>	
39	S52071001	1	ボタンツカミスペーサAL	BUTTON CLAMP SPACER, AL	
40	S52075001	1	ボタンツカミスペーサAR	BUTTON CLAMP SPACER, AR	
41	S52072001	1	ボタンツカミスペーサBL	BUTTON CLAMP SPACER, BL	
42	S52076001	1	ボタンツカミスペーサBR	BUTTON CLAMP SPACER, BR	
43	S52073001	1	ボタンツカミスペーサCL	BUTTON CLAMP SPACER, CL	
44	S52077001	1	ボタンツカミスペーサCR	BUTTON CLAMP SPACER, CR	
45	S52074001	1	ボタンツカミスペーサDL	BUTTON CLAMP SPACER, DL	
46	S52078001	1	ボタンツカミスペーサDR	BUTTON CLAMP SPACER, DR	

F. 下軸関係 / Lower shaft mechanism

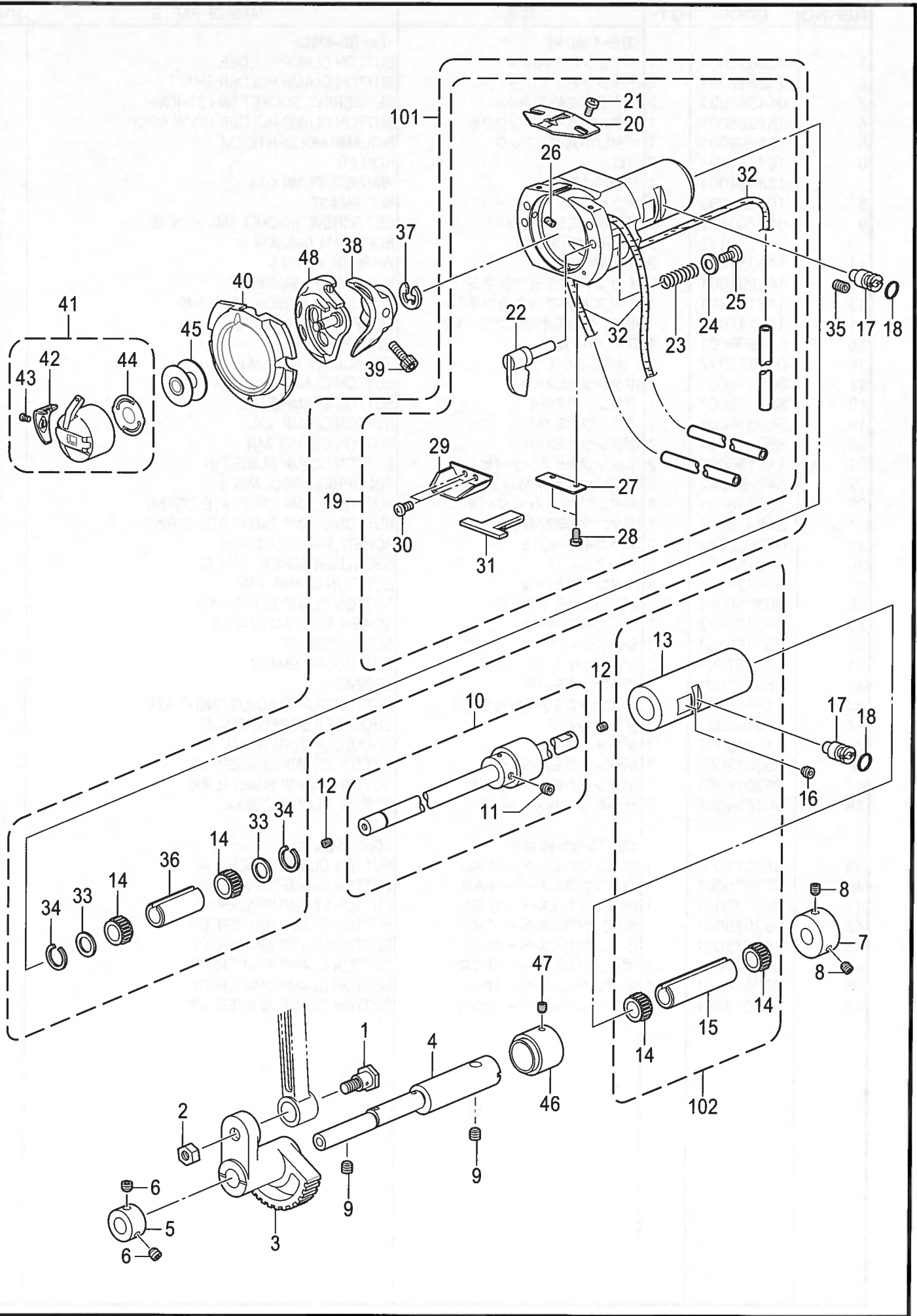



## F. 下軸関係 / Lower shaft mechanism

REF.NO	CODE	Q'TY	品名	NAME OF PARTS	RM
1	SA3226001	1	クランクロッドダンネジ	SHOULDER SCREW	
2	SA3227001	1	ナツト6ホソメ	NUT (FT), M6	
3	SA3228101	1	ヨウドウギヤ	ROCK GEAR	
4	SA4068101	1	ヨウドウギヤジクA	ROCK GEAR SHAFT, A	
5	SA3231001	1	セツトカラ-B	SET SCREW COLLAR, B	
6	012060536	2	アナヒラ6X5	SET SCREW, SOCKET (FT) M6X5	
7	SA3233001	1	セツトカラ-	SET SCREW COLLAR	
8	S23651001	2	アナヒラ6X6ホソメ	SET SCREW, SOCKET (FT) M6X6	
9	012060636	2	アナヒラ6X6	SET SCREW, SOCKET (FT) M6X6	
10	SA3234101	1	シタジククミ	LOWER SHAFT ASSY	
11	012500536	1	アナヒラ5X5	SET SCREW, SOCKET (FT) M5X5	
12	012400436	2	アナヒラ4X4	SET SCREW, SOCKET (FT) M4X4	
13	SA3237001	1	シタジクメタル	LOWER SHAFT BUSH	
14	SA4187001	4	ニードルベアリング	NEEDLE BEARING	
14	SA4188001	4	ニードルベアリング	NEEDLE BEARING	
14	SA4189001	4	ニードルベアリング	NEEDLE BEARING	
14	SA4190001	4	ニードルベアリング	NEEDLE BEARING	
15	SA3273001	1	シタジクカラ-	LOWER SHAFT COLLAR	
16	012060636	1	アナヒラ6X6	SET SCREW, SOCKET (FT) M6X6	
17	SA3238101	2	カマチヨウセツジク	ADJUSTING STUD	
18	081003670	2	OリングPW3	O RING, PW3	
19	SA3239101	1	オオカマタイクミ	SHUTTLE RACE BASE ASSY	
20	S02429201	1	カマイトアンナイ	SHUTTLE RACE THREAD GUIDE	
21	SA4199001	2	シメネジ3X4	SCREW, M3X4	
22	SA3241001	2	オオカマトリツケツメ	S-RACE BASE SETTING CLAW	
23	152684101	2	オオカマトリツケバネ	COMPRESSION SPRING	
24	026030136	2	ヒラザガネコガタ3	WASHER, PLAIN S 3	
25	062300616	2	ナベコ3X6	SCREW, PAN M3X6	
26	153050000	2	オオカマタイフェルト	S-RACE BASE FELT	
27	SA3242001	1	フェルトササエ	FELT HOLDER	
28	S44924001	2	シメネジM3X5.5	SCREW, M3X5.5	
29	SA3274101	1	フェルトオサエ	FELT HOLDER	
30	S47307001	2	シメネジ3X4	SCREW, M3X4	
31	SA3275001	1	ハイユフフェルトT	FELT, T	
32	S59886001	3	フェルト	FELT, L=360	
33	SA3276001	2	スペーサA	SPACER, A	
34	SA3277001	2	トメワ	RETAINING RING	
35	012060636	1	アナヒラ6X6	SET SCREW, SOCKET (FT) M6X6	
36	SA3278001	1	カラ-	COLLAR	
37	048070342	1	トメワE7	RETAINING RING, E7	
38	SA3284001	1	ドライバ-D	DRIVER, D	
39	018501232	1	アナボルト5X12	BOLT, SOCKET M5X12	
40	* P. 53	1	オオカマ	SHUTTLE RACE BASE	
41	* P. 53	1	ボビンケースクミ	BOBBIN CASE ASSY	
42	* P. 53	1	ボビンケースチヨウシバネ	TENSION SPRING	
43	* P. 53	1	ボビンケースバネネジ	SCREW	
44	* P. 53	1	クウテンボウシバネ	ANTI-SPIN SPRING	
45	* P. 53	1	ボビン	BOBBIN	
46	SA3283101	1	セツトカラ-R	SET SCREW COLLAR, R	
47	012500536	1	アナヒラ5X5	SET SCREW, SOCKET (FT) M5X5	
48	* P. 53	1	ナカガマハコクミ	SHUTTLE HOOK ASSY, W/BOX	
101	SA6128001	1	オオカマタイセット	SHUTTLE RACE BASE SET	
102	SA6129001	1	シタジクメタルクミ	LOWER SHAFT BUSH ASSY	

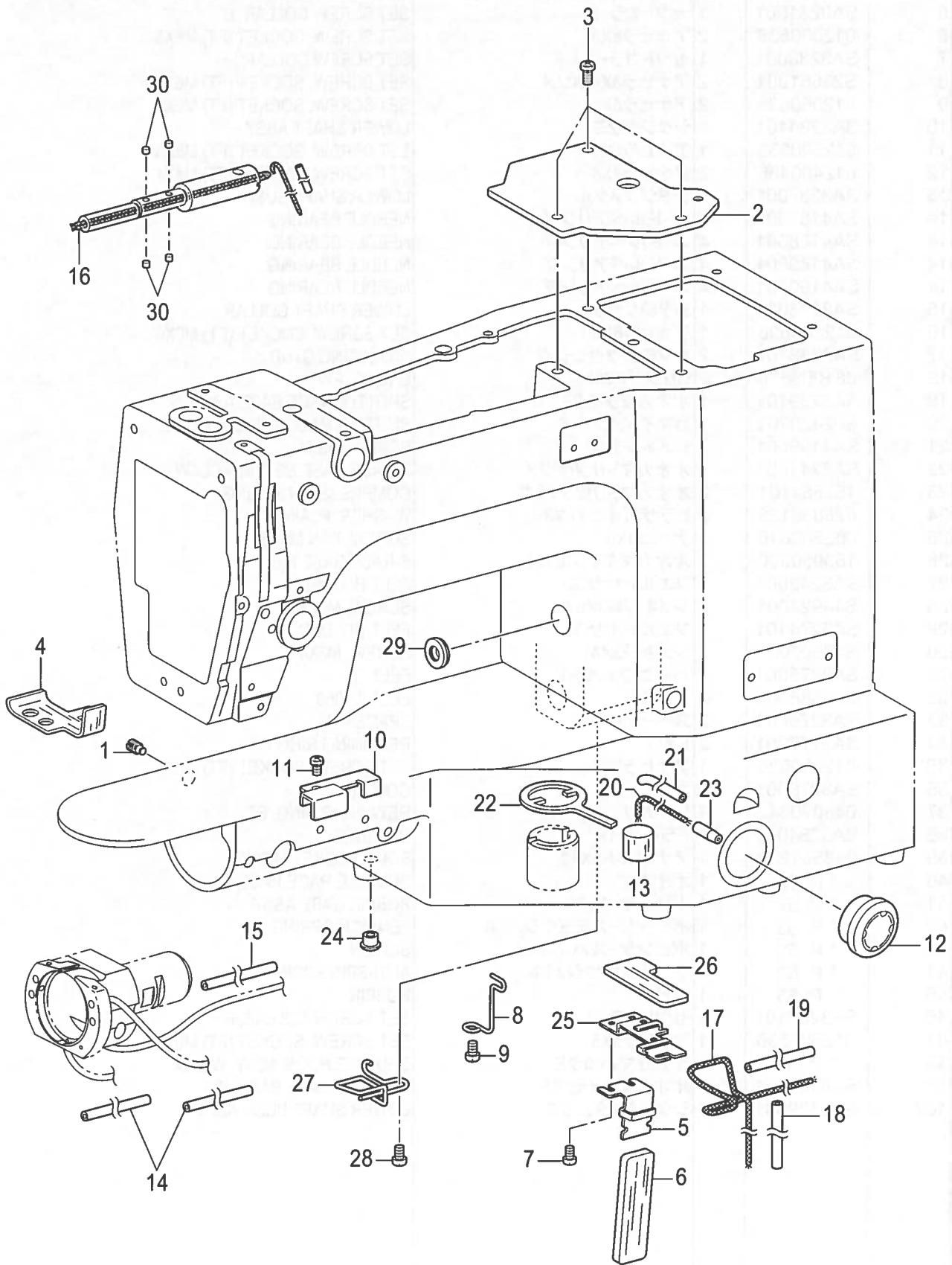

## G. 給油潤滑関係 / Lubrication

REF.NO	CODE	Q'TY	品名	NAME OF PARTS	RM
1	SA3244001	1	トメネジ	SET SCREW	
2	SA3245001	1	クランクカバー	CRANK COVER	
3	062061016	3	ナベコ6X10	SCREW, PAN M6X10	
4	SA3279001	1	スィアゲフェルト	FELT	
5	SA3503201	1	シタジクキュウユササエ	LOWER SHAFT WICK SUPPORT	
6	SA3504201	1	シタジクギヤフェルト	LOWER SHAFT GEAR FELT	
7	062400616	2	ナベコ4X6	SCREW, PAN M4X6	
8	SA3282001	1	コードササエカネA	CORD HOLDER, A	
9	062060816	1	ナベコ6X8	SCREW, PAN M6X8	
10	SA3249001	1	ビニルチューブササエ	OIL TUBE SUPPORT	
11	062400616	1	ナベコ4X6	SCREW, PAN M4X6	
12	S49992000	1	オイルポットマド	OIL GAUGE WINDOW	
13	SA3379001	1	タンクフェルト	FELT	
14	S50529000	2	ビニルチューブ	OIL TUBE, L=320	
15	S28415000	1	ビニルチューブ	OIL TUBE (L=225)	
16	S45849000	1	クミヒモ	WICK, L=300	
17	153922001	1	クミヒモ	WICK, L=500	
18	SA1302001	1	ビニルチューブ	VINYL TUBE	
19	S56877000	1	ビニルチューブ	OIL TUBE	
20	SA8010001	1	フェルト	FELT L=180	
21	143671000	1	ビニルチューブ	OIL TUBE	
22	SA3287001	1	Xオクリレバフェルト	X-FEED LEVER FELT	
23	S07333001	1	オイルクチパイプS	OIL FEEDING PIPE, S	
24	146080000	1	コードブシュ	CORD BUSH	
25	SA3246001	1	ギヤキュウユササエ	GEAR WICK SUPPORT	
26	SA3280001	1	ギヤフェルト	GEAR FELT	
27	SA4221001	1	コードササエカネB	CORD HOLDER, B	
28	062060816	1	ナベコ6X8	SCREW, PAN M6X8	
29	SA4222001	1	フェルトシール	FELT	
30	153050000	4	オオカマタイフェルト	S-RACE BASE FELT	

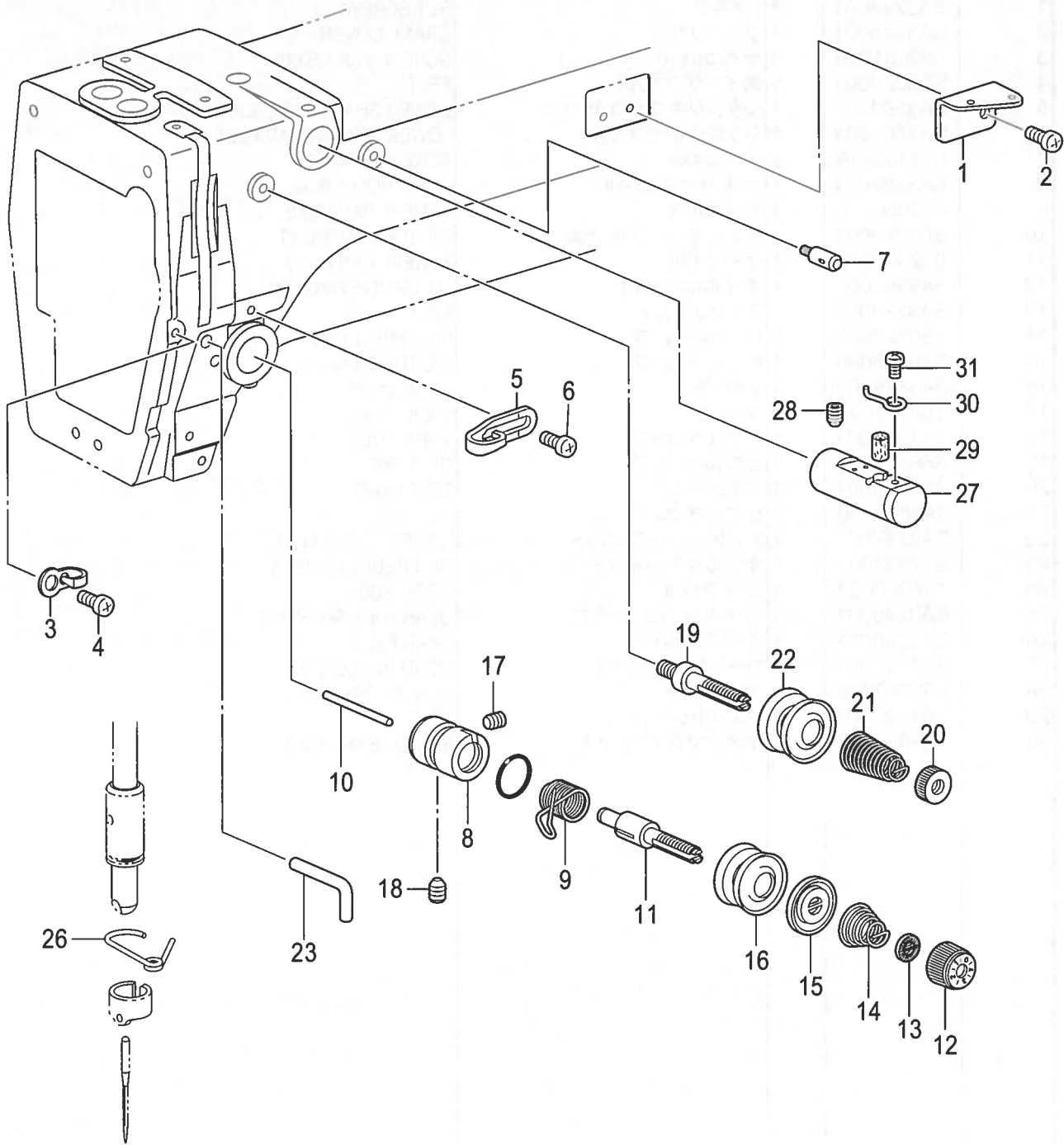

< KE-430D デニム用 / For KE-430D Denim >

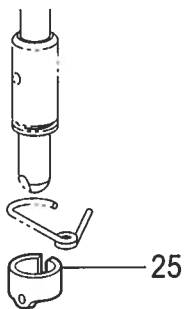

< KE-430D 被服用、メリヤス用、ファンデーション用 / For KE-430D Ordinary materials, Knitted materials & Foundation garments >

< BE-438D 用 / For BE-438D >

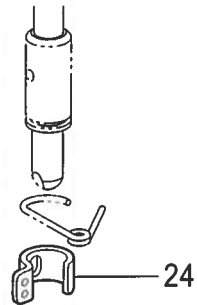

H. 糸通し関係 / Threading mechanism

REF.NO	CODE	Q'TY	品名	NAME OF PARTS	RM
1	SA3250001	1	ア-ムイトミチA	ARM THREAD GUIDE, A	
2	062500616	1	ナベコ5X6	SCREW, PAN M5X6	
3	SA4333001	1	ア-ムイトミチB	ARM THREAD GUIDE, B	
4	062500616	1	ナベコ5X6	SCREW, PAN M5X6	
5	SA3252001	1	ア-ムイトミチC	ARM THREAD GUIDE, C	
6	062500616	1	ナベコ5X6	SCREW, PAN M5X6	
7	153049001	1	ウワイトアンナイボウ	UPPER THREAD GUIDE STUD	
8	SA3254001	1	イトチヨウシダイ	TENSION BRACKET	
9	* P. 53	1	イトトリバネ	THREAD TAKE-UP SPRING	
10	S12699000	1	イトユルメピン	TENSION RELEASE PIN	
11	SA3255001	1	イトチヨウシボウ	TENSION STUD	
12	S31032001	1	イトチヨウシナツト	TENSION NUT	
13	S12441001	1	チヨウシバネウエザガネ	WASHER	
14	* P. 53	1	イトチヨウシバネ	TENSION SPRING	
15	159805001	1	イトチヨウシサラオサエ	TENSION DISC PRESSER	
16	145446001	2	イトチヨウシサラ	DISC, TENSION	
17	100402004	1	トメネジ3.57	SET SCREW, SM3.57	
18	SA4143001	1	アナトメネジ6	SET SCREW, (FT) M6X6	
19	SA3256001	1	イトチヨウシボウA	TENSION STUD, A	
20	100136001	1	イトチヨウシナツト	TENSION NUT	
21	SA4146001	1	フクチヨウシバネ	SUB TENSION SPRING	
22	145446001	2	イトチヨウシサラ	DISC, TENSION	
23	159224001	1	ア-ムイトカケ	THREAD GUIDE, ARM	
			<KE-430D 被服用、メリヤス用、 ファンデーション用> <BE-438D用>	<For KE-430D Ordinary materials, Knitted materials & Foundation garments> <For BE-438D>	
24	SA3635101	1	ハリボウイトアンナイB <KE-430D デニム用>	NEEDLE BAR THREAD GUIDE, B <For KE-430D Denim>	
25	SA3257101	1	ハリボウイトアンナイA	NEEDLE BAR THREAD GUIDE, A	
26	SA3258001	1	ハリボウメタルDイトアンナイ	N-BAR BUSH THREAD GUIDE, D	
27	152881001	1	エキレイタイクミ	NEEDLE COOLER ASSY	
28	012060636	1	アナヒラ6X6	SET SCREW, SOCKET (FT) M6X6	
29	152883000	1	フェルト8X15.5	FELT, 8X15.5	
30	152884001	1	エキレイイトカケ	NEEDLE COOLER THREAD GUIDE	
31	062670412	1	ナベコ3.57-40X4	SCREW, PAN SM3.57-40X4	

KE-430D/BE-438D-401

J. 糸巻関係 / Bobbin winder mechanism

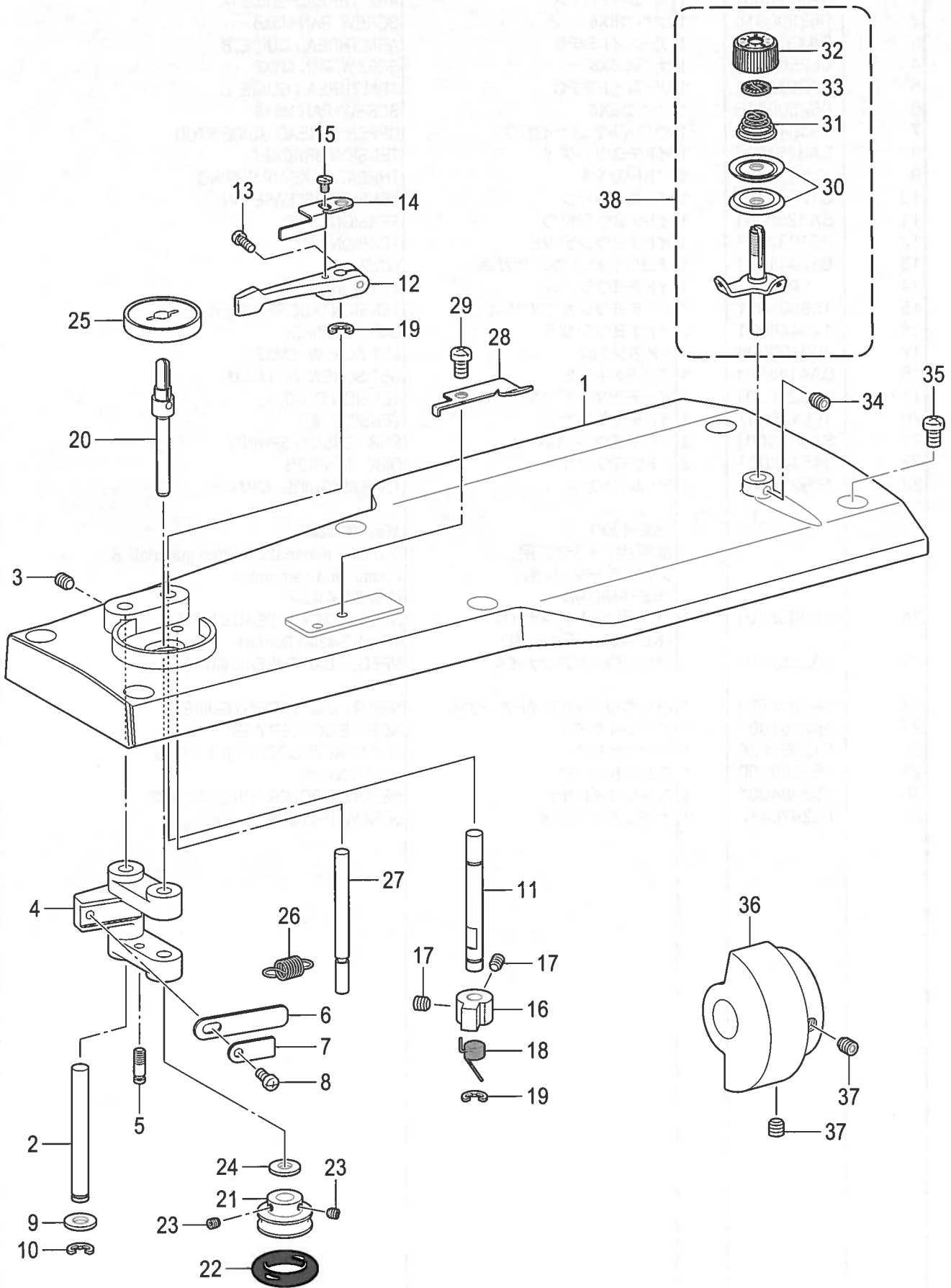

J. 糸巻関係 / Bobbin winder mechanism

REF.NO	CODE	Q'TY	品名	NAME OF PARTS	RM
1	SA3289101	1	ウワフタ	TOP COVER 430D	
2	SA3290001	1	イトマキレバ-ジク	SHAFT, BW-LEVER	
3	012500536	1	アナヒラ5X5	SET SCREW, SOCKET (FT) M5X5	
4	SA3291001	1	イトマキレバ-	BOBBIN WINDER LEVER	
5	SA4171001	1	バネカケ	SPRING HOOK	
6	152936001	1	イタバネ	PLATE SPRING	
7	152937001	1	ザガネ	WASHER	
8	062350616	1	ナベコ35X6	SCREW, PAN M3.5X6	
9	159486001	1	ザガネ	WASHER	
10	048050342	1	トメワE5	RETAINING RING, E5	
11	SA3293001	1	イトマキツメジク	STUD, B-WINDER CLAW	
12	SA1984001	1	ボビンオサエウデ	BOBBIN PRESSER ARM	
13	062401216	1	ナベコ4X12	SCREW, PAN M4X12	
14	SA3294001	1	ボビンオサエ	BOBBIN PRESSER	
15	S23418002	1	シメネジ4X5	SCREW, M4X5	
16	SA3295001	1	イトマキツメ	CLAW, B-WINDER	
17	012400436	2	アナヒラ4X4	SET SCREW, SOCKET (FT) M4X4	
18	S10438001	1	イトマキツメネジリバネ	SPRING, TWIST	
19	048050342	2	トメワE5	RETAINING RING, E5	
20	SA3296001	1	イトマキジク	BOBBIN WINDER SHAFT	
21	SA3297001	1	イトマキクルマ	WHEEL, B-WINDER	
22	120448001	1	ゴムワ	BOBBIN WINDER RUBBER BAND	
23	012400436	2	アナヒラ4X4	SET SCREW, SOCKET (FT) M4X4	
24	159486001	2	ザガネ	WASHER	
25	SA1988001	1	ボビンウケ	BOBBIN SUPPORT	
26	S10268001	1	イトマキレバ-ヒキバネ	SPRING	
27	SA3298001	1	ストツパジク	STPPER SHAFT, B-WINDER	
28	SA3299001	1	メス	KNIFE	
29	062500616	1	ナベコ5X6	SCREW, PAN M5X6	
30	145446001	2	イトチヨウシサラ	DISC, TENSION	
31	100401021	1	イトチヨウシバネ	TENSION SPRING	
32	S31032001	1	イトチヨウシナツト	TENSION NUT	
33	S12441001	1	チヨウシバネウエザガネ	WASHER	
34	012500536	1	アナヒラ5X5	SET SCREW, SOCKET (FT) M5X5	
35	062061016	6	ナベコ6X10	SCREW, PAN M6X10	
36	SA3300001	1	イトマキクドウリン	DRIVINNG WHEEL, B-WINDER	
37	S23651001	2	アナヒラ6X6ホソメ	SET SCREW, SOCKET (FT) M6X6	
38	SA1994101	1	イトマキチヨウシクミ	BOBBIN WINDER TENSION ASSY	

K. 糸切り関係 / Thread trimmer mechanism

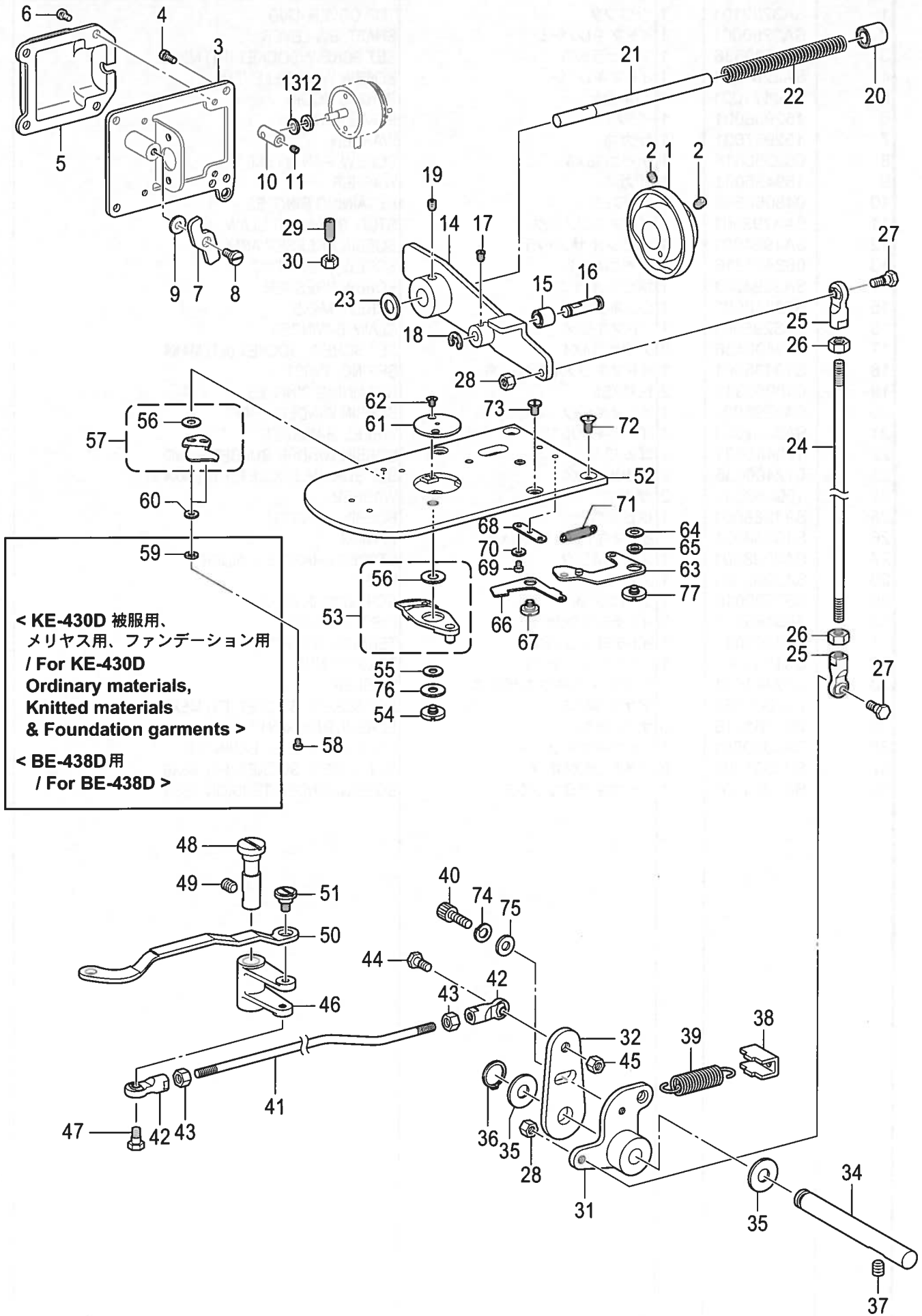

KE-430D/BE-438D-403



K. 糸切り関係 / Thread trimmer mechanism

REF.NO	CODE	Q'TY	品名	NAME OF PARTS	RM
1	SA4131001	1	イトキリカム	THREAD TRIMMER CAM	
2	S23651001	2	アナヒラ6X6ホソメ	SET SCREW, SOCKET (FT) M6X6	
3	SA3304101	1	ソレノイドトリツケイタ	SETTING PLATE, SOLENOID	
4	062400816	4	ナベコ4X8	SCREW, PAN M4X8	
5	SA3303001	1	ソレノイドカバー	TR-SOLENOID COVER	
6	060400516	4	バインド4X5	SCREW, BIND M4X5	
7	SA3305001	1	クドウレバー-オシレバー	PUSHING LEVER, DRIVING LEVER	
8	SA3306001	1	ダンネジ7-3	SHOULDER SCREW, 7-3	
9	S39690021	1	ザガネ	WASHER	
10	SA3307001	1	ソレノイドレバー	SOLENOID LEVER	
11	012400436	1	アナヒラ4X4	SET SCREW, SOCKET (FT) M4X4	
12	154599000	1	ソレノイドクツシヨン	SOLENOID CUSHION	
13	S02652001	1	ザガネ	WASHER	
14	SA3309001	1	イトキリクドウレバー	TR-DRIVING LEVER	
15	SA3310001	1	イトキリコロ	COLLAR, TR-TRIMMER	
16	SA3311001	1	イトキリコロジク	COLLAR SHAFT	
17	012400436	1	アナヒラ4X4	SET SCREW, SOCKET (FT) M4X4	
18	048040342	1	トメワE4	RETAINING RING, E4	
19	S23651001	1	アナヒラ6X6ホソメ	SET SCREW, SOCKET (FT) M6X6	
20	231071001	1	メタル8X15	BUSH, 8X15	
21	SA3312201	1	クドウレバー-アンナイジク	GUIDE SHAFT	
22	SA3313101	1	クドウジクバネ	SPRING, COMPRESSION	
23	154596000	1	イトキリカムレバークツシヨン	CUSHION	
24	SA3315001	1	イトキリロツドV	THREAD TRIMMER ROD V	
25	S32465001	2	タマツギテクミ	BALL JOINT ASSY	
26	021060106	2	1シュナツト6	NUT, 1 M6	
27	S32462001	2	タマツギテダンネジB	SHOULDER SCREW, B; M6	
28	021060306	2	3シュナツト6	NUT, 3 M6	
29	S25475001	1	トメネジ6	SET SCREW, M6X19	
30	021060106	1	1シュナツト6	NUT, 1 M6	
31	SA4546001	1	イトキリレバー-V	THREAD TRIMMER LEVER V	
32	SA3317001	1	イトキリレバー-H	THREAD TRIMMER LEVER H	
34	SA3319101	1	イトキリレバー-ジク	SHAFT, TR-TRIMMER LEVER	
35	SA4545001	2	カンザ	SPECER	
36	048080142	1	トメワジクヨウC8	RETAINING RING EXTERNAL C8	
37	012060636	2	アナヒラ6X6	SET SCREW, SOCKET (FT) M6X6	
38	SA3320101	1	バネカケ	SPRING HOOK	
39	SA3321001	1	イトキリモドシバネ	SPRING, EXTENSION	
40	018501232	1	アナボルト5X12	BOLT, SOCKET M5X12	
74	028050246	1	バネザガネ2-5	WASHER SPRING 2-5	
75	146352002	1	ザガネ	WASHER, PLAIN 5	
41	SA3323001	1	イトキリロツドH	THREAD TRIMMER ROD H	
42	S32465001	2	タマツギテクミ	BALL JOINT ASSY	
43	021060106	2	1シュナツト6	NUT, 1 M6	
44	S32462001	1	タマツギテダンネジB	SHOULDER SCREW, B; M6	
45	021060306	1	3シュナツト6	NUT, 3 M6	
46	SA3324001	1	イドウハレバー	MOVING KNIFE LEVER	
47	SA3325001	1	ダンネジ6.35-6	SHOULDER SCREW, 6.35-6	
48	SA3326001	1	イドウハレバー-ジク	SHAFT, M-KNIFE LEVER	
49	012060636	1	アナヒラ6X6	SET SCREW, SOCKET (FT) M6X6	
50	SA3327101	1	イドウハレカン	M-KNIFE CONNECTING PLATE	
51	SA4354001	1	ダンネジ6-1.8	SHOULDER SCREW, 6-1.8	
52	SA3655001	1	ハリイタSC	NEEDLE PLATE, SC	

K. 糸切り関係 / Thread trimmer mechanism

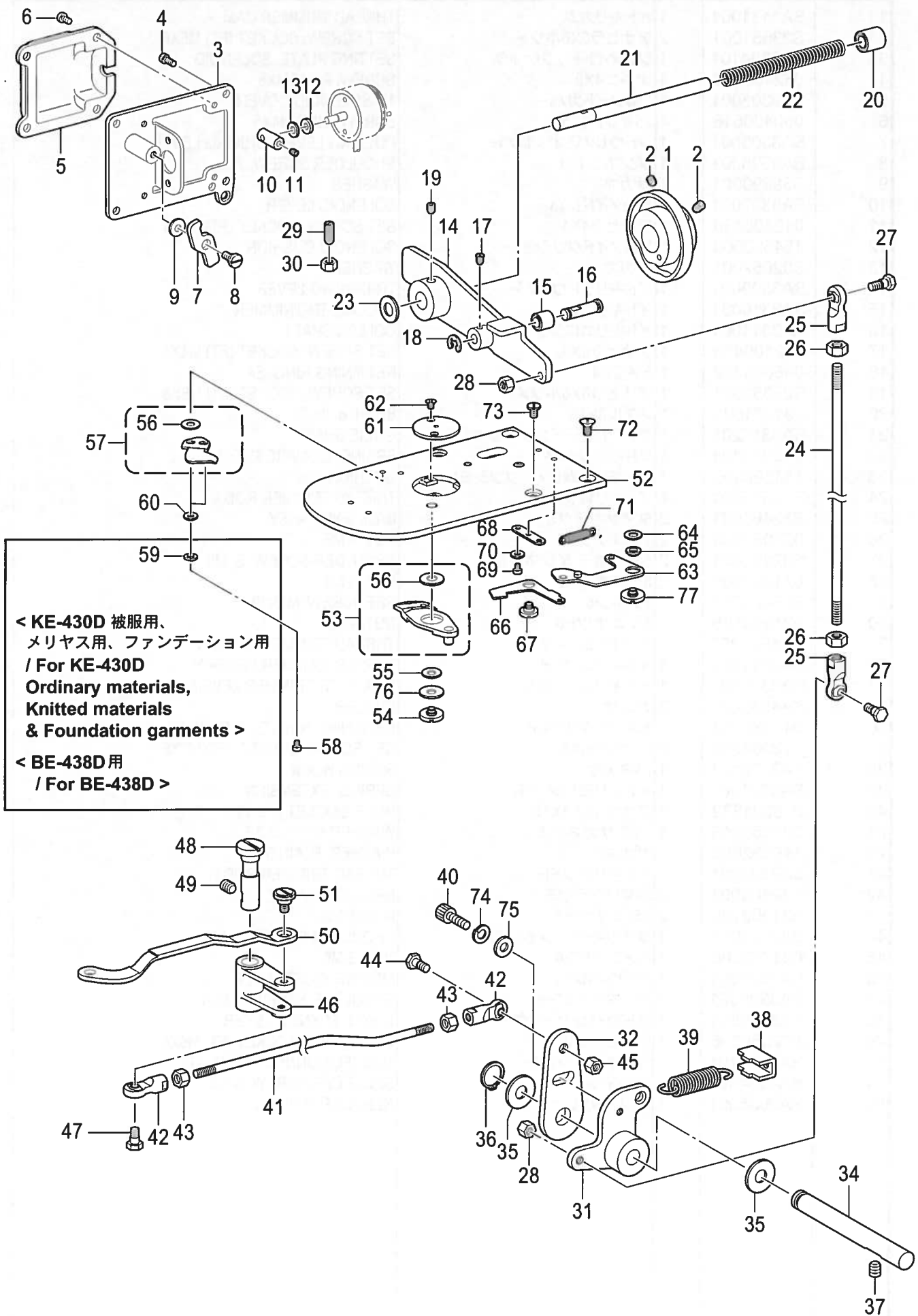

KE-430D/BE-438D-403

K. 糸切り関係 / Thread trimmer mechanism

REF.NO	CODE	Q'TY	品名	NAME OF PARTS	RM
			<KE-430D 被服用、メリヤス用、 ファンデーション用>	<For KE-430D Ordinary materials, Knitted materials & Foundation garments>	
53	SA6429001	1	イドウハF-SCセット	MOVABLE KNIFE SET F-SC	
56	SA6397001	1	イドウハカンザ0.2	M-KNIFE SPACER T0.2	
56	SA3334001	1	イドウハカンザ0.3	M-KNIFE SPACER T0.3	
56	SA6398001	1	イドウハカンザ0.4	M-KNIFE SPACER T0.4	
			<KE-430D デニム用>	<For KE-430D Denim>	
53	SA6596001	1	イドウハFセット	MOVABLE KNIFE SET F	
56	SA6397001	1	イドウハカンザ0.2	M-KNIFE SPACER T0.2	
56	SA3334001	1	イドウハカンザ0.3	M-KNIFE SPACER T0.3	
56	SA6398001	1	イドウハカンザ0.4	M-KNIFE SPACER T0.4	
			<BE-438D用>	<For BE-438D>	
53	SA6432001	1	イドウハF-SCSセット	MOVABLE KNIFE SET F-SCS	
56	SA6397001	1	イドウハカンザ0.2	M-KNIFE SPACER T0.2	
56	SA3334001	1	イドウハカンザ0.3	M-KNIFE SPACER T0.3	
56	SA6398001	1	イドウハカンザ0.4	M-KNIFE SPACER T0.4	
54	SA4518001	1	イドウハダンネジ	MOVABLE KNIFE SHOULDER SCREW	
76	SA4519001	1	スラストザガネ	THRUST WASHER	
55	S00705001	1	イドウハカラ-	MOVABLE KNIFE COLLAR	
			<KE-430D 被服用、メリヤス用、 ファンデーション用> <BE-438D用>	<For KE-430D Ordinary materials, Knitted materials & Foundation garments> <For BE-438D>	
57	SA6431001	1	コテイハF-SCセット	FIXED KNIFE SET F-SC	
56	SA6397001	1	イドウハカンザ0.2	M-KNIFE SPACER T0.2	
56	SA3334001	1	イドウハカンザ0.3	M-KNIFE SPACER T0.3	
56	SA6398001	1	イドウハカンザ0.4	M-KNIFE SPACER T0.4	
			<KE-430D デニム用>	<For KE-430D Denim>	
57	SA6597001	1	コテイハFセット	FIXED KNIFE SET F	
56	SA6397001	1	イドウハカンザ0.2	M-KNIFE SPACER T0.2	
56	SA3334001	1	イドウハカンザ0.3	M-KNIFE SPACER T0.3	
56	SA6398001	1	イドウハカンザ0.4	M-KNIFE SPACER T0.4	
58	062300416	2	ナベコ3X4	SCREW, PAN M3X4	
			<KE-430D 被服用、メリヤス用、 ファンデーション用> <BE-438D用>	<For KE-430D Ordinary materials, Knitted materials & Foundation garments> <For BE-438D>	
59	028030246	2	バネザガネ2-3	WASHER, SPRING2-3	
60	025030236	2	ヒラザガネチユウ3	WASHER, PLAIN M 3	
61	* P. 53, 57	1	ハリアナイタ	NEEDLE HOLE PLATE	
62	100360003	2	サラネジ2.38	SCREW	
63	SA3337001	1	イトツカミDクミ	THREAD NIPPER ASSY D	
64	SA4330001	1	イトツカミカンザ	SPACER, THREAD NIPPER	
65	SA4329001	1	イトツカミカラ-	COLLAR, THREAD NIPPER	
66	SA3341001	1	イトオサエU	THREAD NIPPER U	
77	SA3333001	1	イトツカミダンネジ	THREAD NIPPER SHOULDER SCREW	
67	SA3342001	1	ダンネジ6-0.9	SHOULDER SCREW, 6-0.9	
68	SA3343001	1	バネカケイタ	PLATE, SPRING HOOK	
69	062300416	2	ナベコ3X4	SCREW, PAN M3X4	
70	025030236	2	ヒラザガネチユウ3	WASHER, PLAIN M 3	
71	SA3344001	1	イトツカミバネ	SPRING, EXTENSION	
72	S25310101	2	サラネジ4	SCREW, FLAT M4	
73	SA3538001	2	シメネジ4X8	SCREW, M4X8	

KE-430D/BE-438D-403

L. 糸払い関係 / Thread wiper mechanism

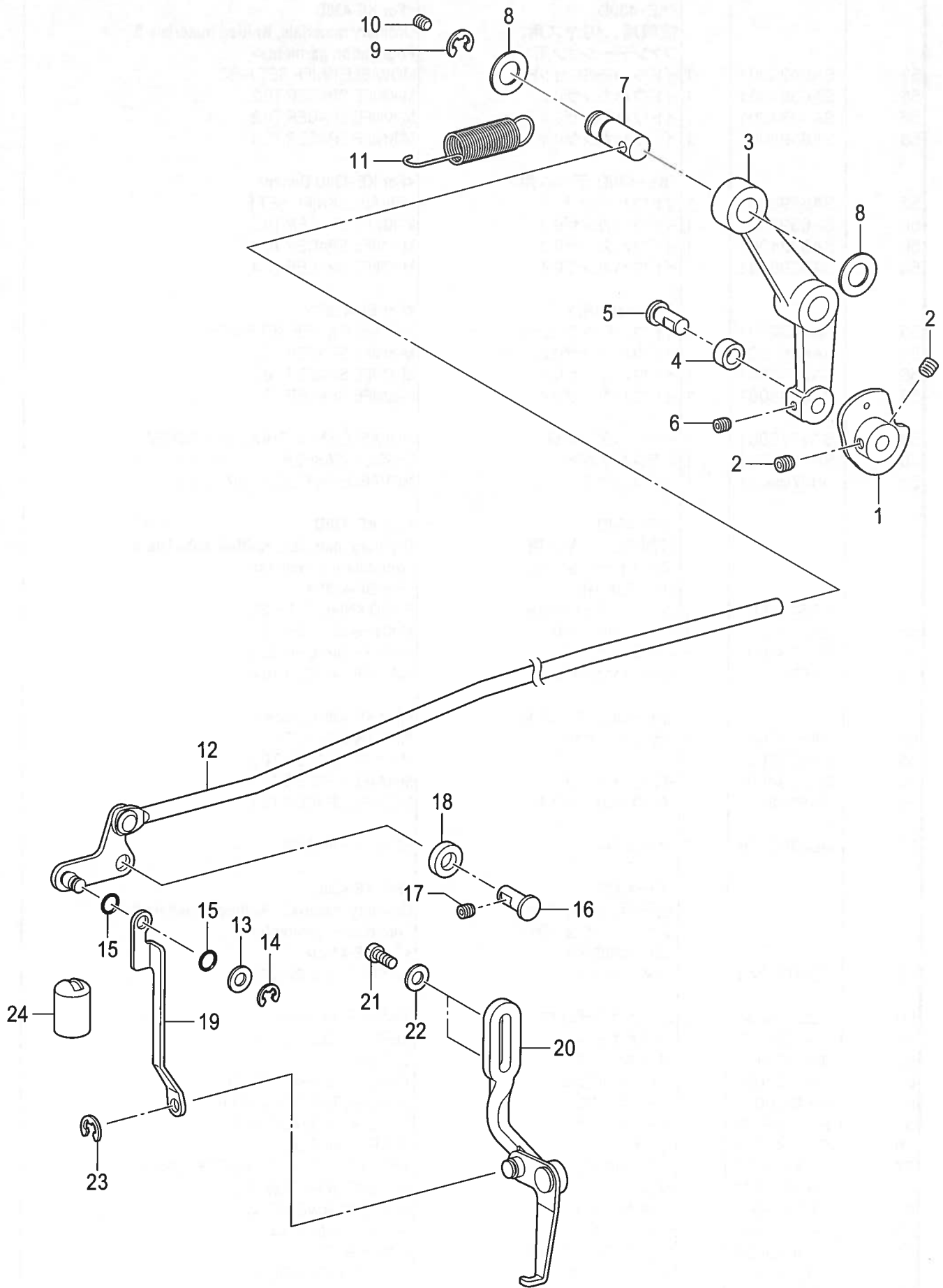

KE-430D/BE-438D-405

## L. 糸払い関係 / Thread wiper mechanism

REF.NO	CODE	Q'TY	品名	NAME OF PARTS	RM
1	SA3447001	1	ワイパーカム	THREAD WIPER CAM	
2	012060636	2	アナヒラ6X6	SET SCREW, SOCKET (FT) M6X6	
3	SA3448001	1	ワイパークドウレバー	DRIVING LEVER,; THREAD WIPER	
4	SA3449001	1	ワイパーコロ	THREAD WIPER ROLLER	
5	SA3441001	1	オサエアゲコロジク	W-CLAMP LIFTER ROLLER SHAFT	
6	012500536	1	アナヒラ5X5	SET SCREW, SOCKET (FT) M5X5	
7	SA3451001	1	ワイパーロッドジク	THREAD WIPER ROD SHAFT	
8	S20356001	2	ヒラザガネ10	WASHER, PLAIN 10	
9	048080342	1	トメワE8	RETAINING RING, E8	
10	012500536	1	アナヒラ5X5	SET SCREW, SOCKET (FT) M5X5	
11	SA3446001	1	オサエアゲバネ	SPRING	
12	SA3452001	1	ワイパーロッドクミ	THREAD WIPER ROD ASSY	
13	025050134	1	ヒラザガネシヨウ5	WASHER, PLAIN S 5	
14	048040342	1	トメワE4	RETAINING RING, E4	
15	081005070	2	OリングP5	O RING, P5	
16	SA3441001	1	オサエアゲコロジク	W-CLAMP LIFTER ROLLER SHAFT	
17	012500536	1	アナヒラ5X5	SET SCREW, SOCKET (FT) M5X5	
18	S38033002	1	カラ-13	COLLAR, 13	
19	SA3458001	1	ワイパーレンケツイタ	CONNECTING PLATE	
20	SA3459101	1	ワイパーウデクミ	THREAD WIPER ARM ASSY	
21	062401006	2	ナベコ4X10	SCREW, PAN M4X10	
22	025040236	2	ヒラザガネチユウ4	WASHER, PLAIN M 4	
23	048040342	1	トメワE4	RETAINING RING, E4	
24	SA3464001	1	オイルキリセン	OIL CAP	

M.糸緩め関係 / Tension release mechanism

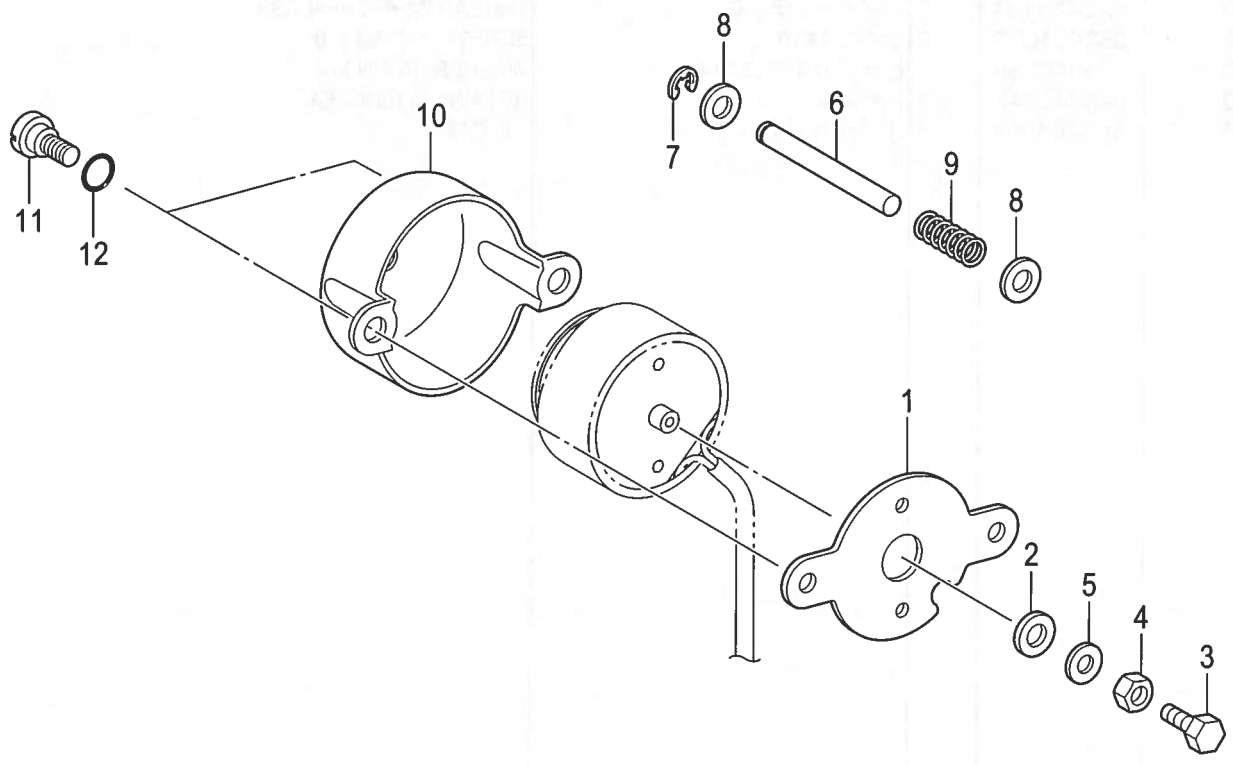

M. 糸緩め関係 / Tension release mechanism

REF.NO	CODE	Q'TY	品名	NAME OF PARTS	RM
1	SA3345001	1	ソレノイドトリツケイタ	SETTING PLATE, SOLENOID	
2	154599000	1	ソレノイドクツシヨソ	SOLENOID CUSHION	
3	017401015	1	ボルト4X10	BOLT, M4X10	
4	021400306	1	3シユナツト4	NUT, 3 M4	
5	102707002	1	ザガネ	WASHER	
6	SA3347001	1	イトユルメボウ	TENSION RELEASE BAR	
7	048040342	1	トメフE4	RETAINING RING, E4	
8	025050236	2	ヒラザガネチユウ5	WASHER, PLAIN M 5	
9	SA3348001	1	コイルバネ	SPRING, COMPRESSION	
10	SA3349001	1	ソレノイドカバー	SOLENOID COVER	
11	SA3306001	2	ダンネジ7-3	SHOULDER SCREW, 7-3	
12	081007070	2	OリングP7	O RING P7	

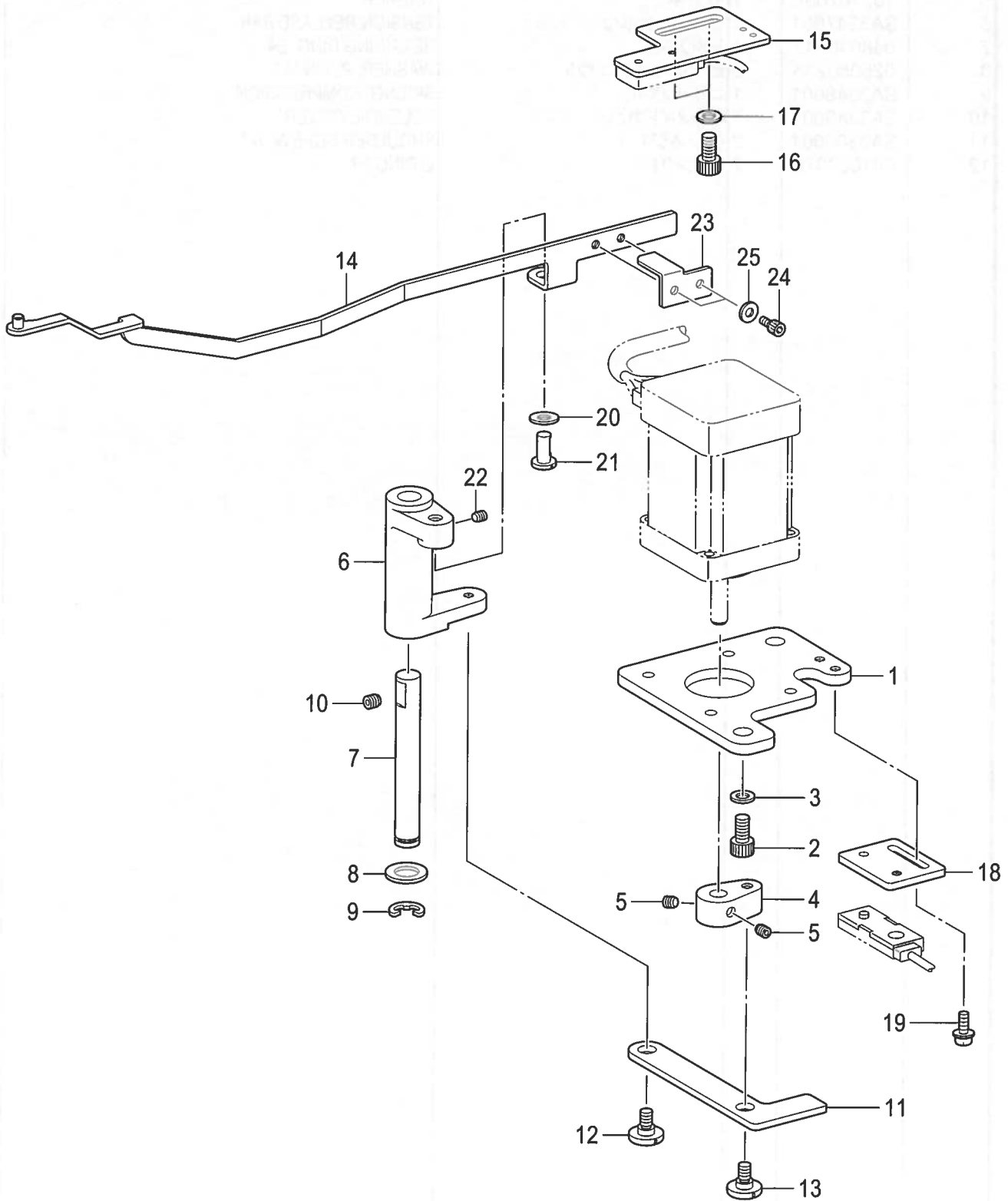



N. 糸つかみ関係 / Thread nipper mechanism

REF.NO	CODE	Q'TY	品名	NAME OF PARTS	RM
1	SA3351001	1	TNモーターリツケイタ	SETTING PLATE, TN-MOTOR	
2	018061236	2	アナボルト6X12	BOLT, SOCKET M6X12	
3	15559001	2	ヒラザガネチュウ6	WASHER, PLAIN M 6	
4	SA3352101	1	イトツカミモーターレバー	TN-MOTOR LEVER	
5	012400436	2	アナヒラ4X4	SET SCREW, SOCKET (FT) M4X4	
6	SA3353201	1	イトツカミレバー	TN-LEVER	
7	SA3354001	1	イトツカミレバージク	TN-LEVER SHAFT	
8	153596001	1	ザガネ	WASHER	
9	048070342	1	トメワE7	RETAINING RING, E7	
10	012060636	1	アナヒラ6X6	SET SCREW, SOCKET (FT) M6X6	
11	SA3355001	1	イトツカミレンケツイタB	TN-CONNECTING PLATE B	
12	SA4461001	1	ダンネジ6-3.5	SHOULDER SCREW, 6-3.5	
13	SA4354001	1	ダンネジ6-1.8	SHOULDER SCREW, 6-1.8	
14	SA3357101	1	イトツカミレンケツイタFクミ	TN-CONNECTING PLATE ASSY F	
23	SA5137001	1	イトツカミセンサードグ	TN-SENSOR DOG	
24	018300636	2	アナボルト3X6	BOLT SOCKET M3X6	
25	025030236	2	ヒラザガネチュウ3	WASHER PLAIN M 3	
15	SA5138001	1	TNセンサートリツケイタB	SETTING PLATE B, TN-SENSOR	
16	018061236	2	アナボルト6X12	BOLT, SOCKET M6X12	
17	15559001	2	ヒラザガネ	WASHER, PLAIN	
18	SA3361001	1	TNセンサートリツケイタF	SETTING PLATE F, TN-SENSOR	
19	0A4300805	2	ナベザクミ3X8DA	SCREW, PAN (S/P WASHER) M3X8	
20	15559001	1	ヒラザガネ	WASHER, PLAIN	
21	S10202201	1	レンカンレバージク	LEVER SHAFT	
22	012400436	1	アナヒラ4X4	SET SCREW SOCKET (FT) M4X4	

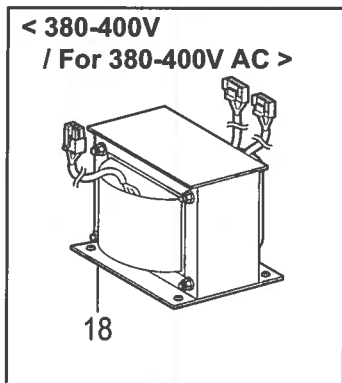
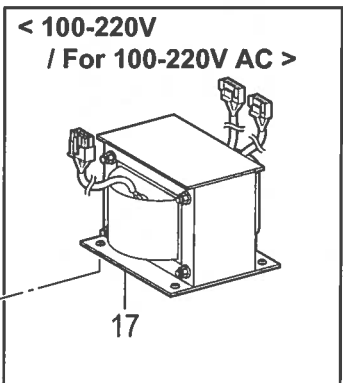
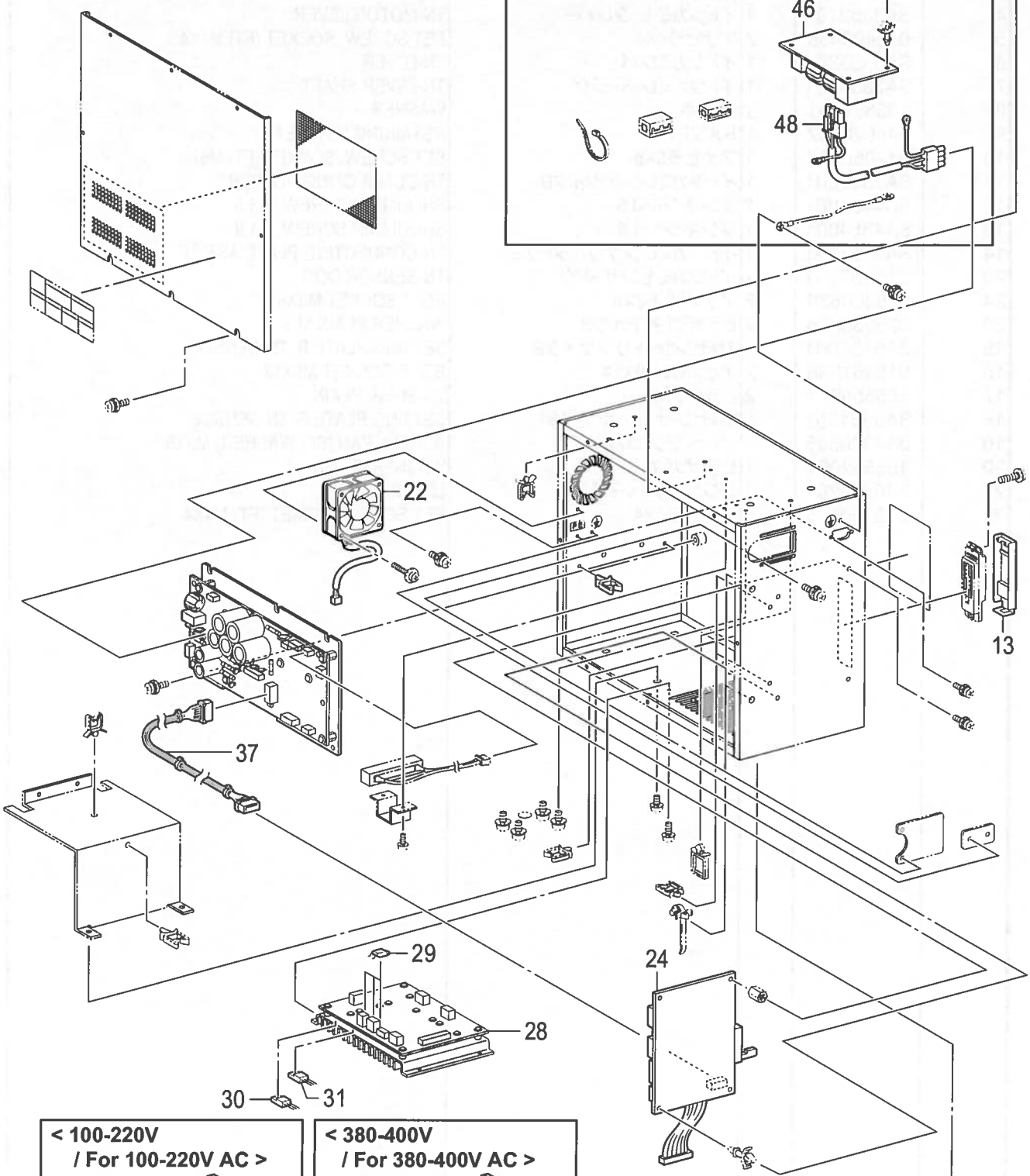
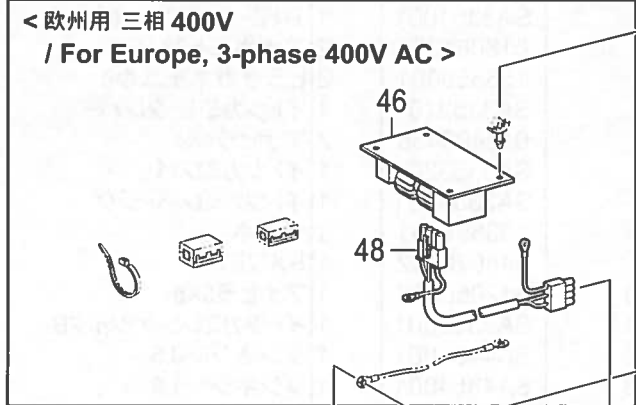

P1. コントロールボックス関係 / Control box mechanism

REF.NO	CODE	Q'TY	品名	NAME OF PARTS	RM
13	SA6364001	1	CFキャップクミ	CF CAP ASSY	
			<100-220V>	<For 100-220V AC>	
17	SA3720101	1	トランスLV	TRANSFORMER LOW VOLTAGE	
			<380-400V>	<For 380-400V AC>	
18	SA3808101	1	トランスHV	TRANSFORMER HIGH VOLTAGE	
22	SA3797001	1	DCファンモータクミ	DC-FAN MOTOR ASSY	
24	SA3724101	1	メインキバンクミ	PCB ASSY, MAIN	
28	SA3739501	1	PMDキバンクミ	PCB ASSY, PMD	
29	SA3744001	3	FET FS10ASJ-2	TRANSISTOR, FET: FS10ASJ-2	
30	SA3722001	1	MOSFET FX20KMJ2	TRANSISTOR, FET: FX20KMJ-2	
31	S49484000	1	MOSFETFS10KMJ-2	TRANSISTOR, FET: FS10KMJ-2	
37	SA3806001	1	MAINデンゲンハーネス	HARNESS, MAIN POWER SUPPLY	
			<欧州用 三相 400V>	<For Europe, 3-phase 400V AC>	
46	SA3581001	1	フィルタキバンクミ	PCB ASSY, NF	
48	SA3796001	1	NF OUTコード	HARNESS, NF OUT	

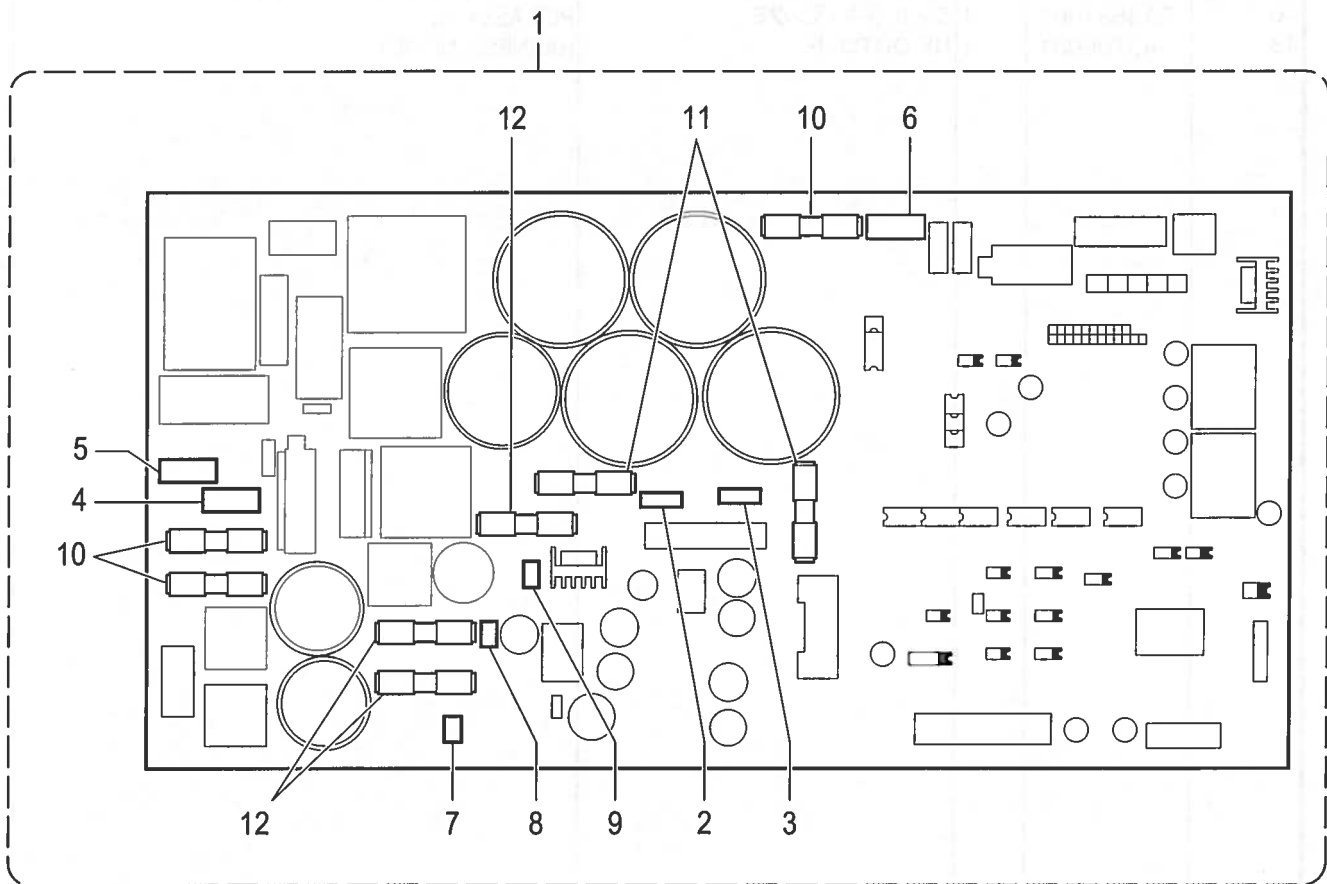

P2. コントロールボックス (電源基板) 関係 / Control box (PCB) mechanism

REF.NO	CODE	Q'TY	品名	NAME OF PARTS	RM
1	SA3755301	1	デンゲンモータキバンクミ	PCB ASSY, POWER SUPPLY MOTOR	
2	SA3765001	1	バリスタTND10V101K	VARISTOR: V10D101	
3	SA3766001	1	バリスタTND10V241K	VARISTOR: V10D241	
4	SA3767001	1	バリスタTND14V511K	VARISTOR: V14D511	
5	SA3762001	1	バリスタTND14V911K	VARISTOR: V14D911	
6	SA3768001	1	バリスタTND14V561K	VARISTOR: V14D561	
7	SA3769001	1	バリスタTND5V121K	VARISTOR: V5D121	
8	SA3770001	1	バリスタTND5V330K	VARISTOR: V5D330	
9	SA3771001	1	バリスタTND5V820K	VARISTOR: V5D820	
10	SA3794001	3	FGMB 250V-15A	G FUSE S 15A	
11	SA3795001	2	FGMB 250V-6A	G FUSE S 6A	
12	616167001	3	GヒューズS 3A	G FUSE S 3A	

< 日本用 单相 100V / For Japan, 1-phase 100V AC. >

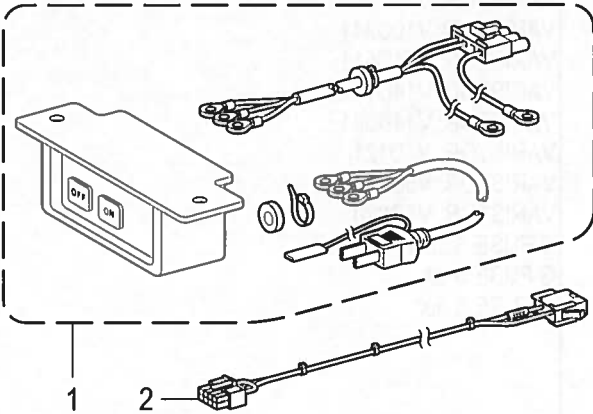

< 日本用 三相 200V / For Japan, 3-phase 200V AC. >

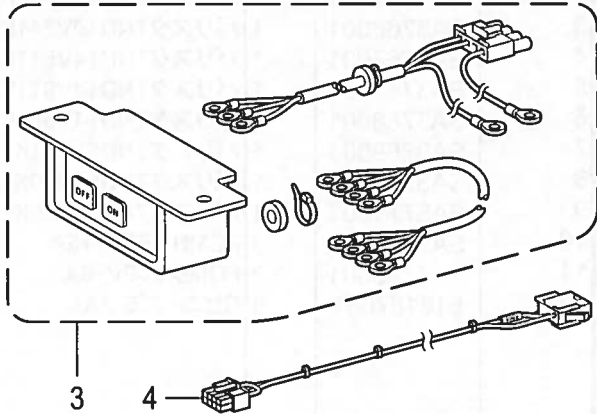

< USA 用 单相 110V / For USA, 1-phase 110V AC. >

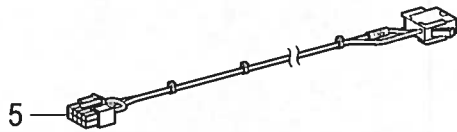

< USA 用 三相 220V / For USA, 3-phase 220V AC. >

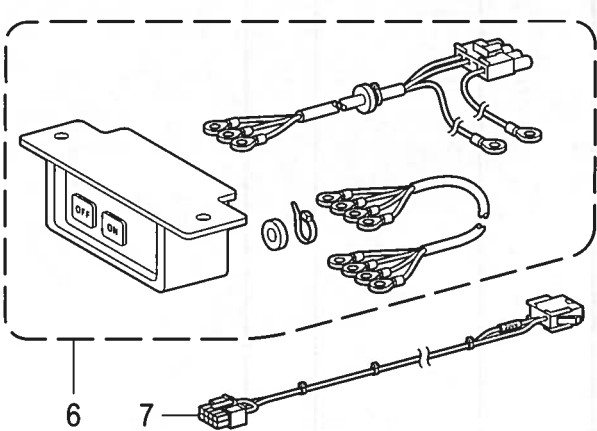

< アジア用 单相 220V / For Asia, 1-phase 220V AC. >

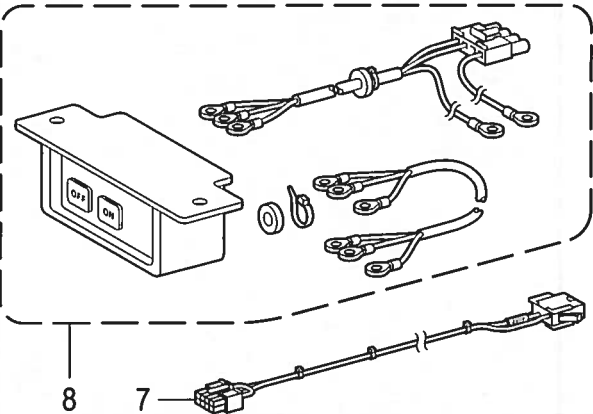

< 中国用 单相 220V / For China, 1-phase 220V AC. >

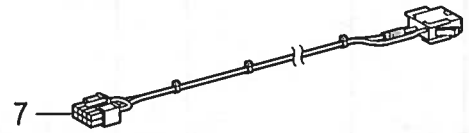

< アジア用 单相 240V / For Asia, 1-phase 240V AC. >

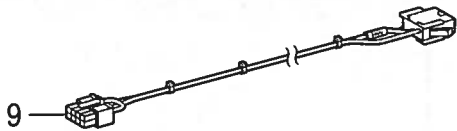

< 中国用 三相 380V / For China, 3-phase 380V AC. >

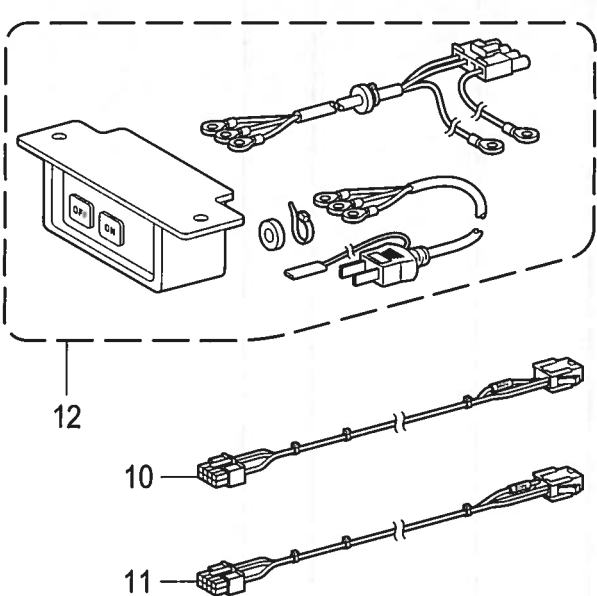

< 欧州用 三相 400V / For Europe, 3-phase 400V AC. >

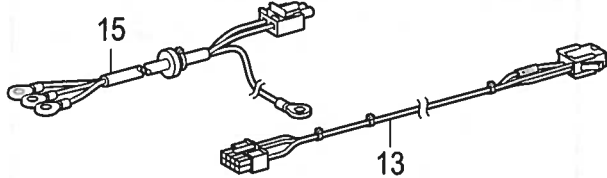

< カナダ用 单相 120V / For USA, 1-phase 120V AC. >

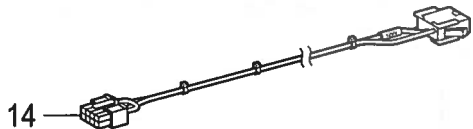

Q. スイッチ関係 / Power switch mechanism

REF.NO	CODE	Q'TY	品名	NAME OF PARTS	RM
1	SA3813101	1	<日本用 単相 100V> デンSWクミ1P-JPN	<For Japan, 1-phase 100V AC.> POWER SUPPLY SWITCH ASSY 1P-JP	
2	SA3822001	1	Vキリカエハーネス100V	VOLTAGE SELECT HARNESS 100V	
3	SA3819101	1	<日本用 三相 200V> デンSWクミ3P-JPN	<For Japan, 3-phase 200V AC.> POWER SUPPLY SWITCH ASSY 3P-JP	
4	SA3825001	1	Vキリカエハーネス200V	VOLTAGE SELECT HARNESS 200V	
5	SA3823001	1	<USA用 単相 110V> Vキリカエハーネス110V	<For USA, 1-phase 110V AC.> VOLTAGE SELECT HARNESS 110V	
6	SA3816101	1	<USA用 三相 220V> デンSWクミ3P-L	<For USA, 3-phase 220V AC.> POWER SUPPLY SWITCH ASSY 3P-L	
7	SA3812001	1	Vキリカエハーネス220V	VOLTAGE SELECT HARNESS 220V	
8	SA3809101	1	<アジア用 単相 220V> デンSWクミ1P	<For Asia, 1-phase 220V AC.> POWER SUPPLY SWITCH ASSY 1P	
7	SA3812001	1	Vキリカエハーネス220V	VOLTAGE SELECT HARNESS 220V	
9	SA3826001	1	<アジア用 単相 240V> Vキリカエハーネス240V	<For Asia, 1-phase 240V AC.> VOLTAGE SELECT HARNESS 240V	
7	SA3812001	1	<中国用 単相 220V> Vキリカエハーネス220V	<For China, 1-phase 220V AC.> VOLTAGE SELECT HARNESS 220V	
12	SA4510101	1	<中国用 三相 380V> デンSWクミ3P-H	<For China, 3-phase 380V AC.> POWER SUPPLY SWITCH ASSY, 3P-H	
10	SA3827001	1	Vキリカエハーネス380V	VOLTAGE SELECT HARNESS 380V	
11	SA3789101	1	VキリカエハーネスH220V	VOLTAGE SELECT HARNESS H220V	
15	SA3838101	1	<欧州用 三相 400V> ACINコードECクミ	<For Europe, 3-phase 400V AC.> HARNESS ASSY AC IN EC	
13	SA3828001	1	Vキリカエハーネス400V	VOLTAGE SELECT HARNESS 400V	
14	SA3824001	1	<カナダ用 単相 120V> Vキリカエハーネス120V	<For Canada, 1-phase 120V AC.> VOLTAGE SELECT HARNESS 120V	





## R. 電装品関係 / Power supply equipment mechanism

REF.NO	CODE	Q'TY	品名	NAME OF PARTS	RM
1	SA3465201	1	パルスモータXクミ	PULSE MOTOR ASSY X	
2	018401036	4	アナボルト4X10	BOLT, SOCKET M4X10	
3	SA3469201	1	パルスモータYクミ	PULSE MOTOR ASSY Y	
4	018400836	4	アナボルト4X8	BOLT, SOCKET M4X8	
5	SA3472201	1	パルスモータPクミ	PULSE MOTOR ASSY P	
6	018401036	4	アナボルト4X10	BOLT, SOCKET M4X10	
7	SA4127001	1	イトツカミPMクミ	PULSE MOTOR ASSY, THREAD CATCH	
8	062300816	4	ナベコ3X8	SCREW, PAN M3X8	
9	028030246	4	バネザガネ2-3	WASHER, SPRING 2-3	
10	SA3477001	1	イトツカミゲンテンセンサクミ	HOME POSITION SENSOR THREAD-C	
11	062300816	2	ナベコ3X8	SCREW, PAN M3X8	
12	SA4347001	1	イトユルメソレノイドクミ	TENSION RELEASE SOLENOID ASSY	
13	017400802	2	ボルト4X8	BOLT, M4X8	
14	028040246	2	バネザガネ2-4	WASHER, SPRING 2-4	
15	025040236	2	ヒラザガネチュウ4	WASHER, PLAIN M4	
16	149547000	2	コードオサエ	CORD HOLDER, 4N	
17	0A5401006	2	+ナベザクミ4X10DB	SCREW, PAN (S/P WASHER) M4X10	
18	SA4348001	1	イトキリソレノイドクミ	THREAD TRIMMER SOLENOID, ASSY	
19	017400802	2	ボルト4X8	BOLT, M4X8	
20	028040246	2	バネザガネ2-4	WASHER, SPRING 2-4	
21	025040236	2	ヒラザガネチュウ4	WASHER, PLAIN M4	
22	146202000	1	ナイロンクリツブ	CORD HOLDER, 6N	
23	0A5401006	1	+ナベザクミ4X10DB	SCREW, PAN (S/P WASHER) M4X10	
24	SA3481001	1	トウブSWクミ	SWITCH ASSY, MACHINE HEAD	
25	0A5301605	2	+ナベザクミ3X16DB	SCREW, PAN(S/P WASHE) M3X16	
26	SA3523001	1	トウブケンシュツユニットクミ	HEAD DETECTOR UNIT, ASSY	
33	J04392001	1	LEDカバー	LED COVER	
27	0A5401006	2	+ナベザクミ4X10DB	SCREW, PAN (S/P WASHER) M4X10	
28	SA3486001	1	アースセン350	GROUND WIRE, 350	
29	0A5401006	2	+ナベザクミ4X10DB	SCREW, PAN (S/P WASHER) M4X10	
30	S11817000	1	クランプNK-18N	CLAMP, NK-18N	
31	554482000	1	コードホルダ#12	CORD HOLDER, #12	
32	0A5401006	2	+ナベザクミ4X10DB	SCREW, PAN (S/P WASHER) M4X10	

S. 操作パネル関係 / Operation panel mechanism

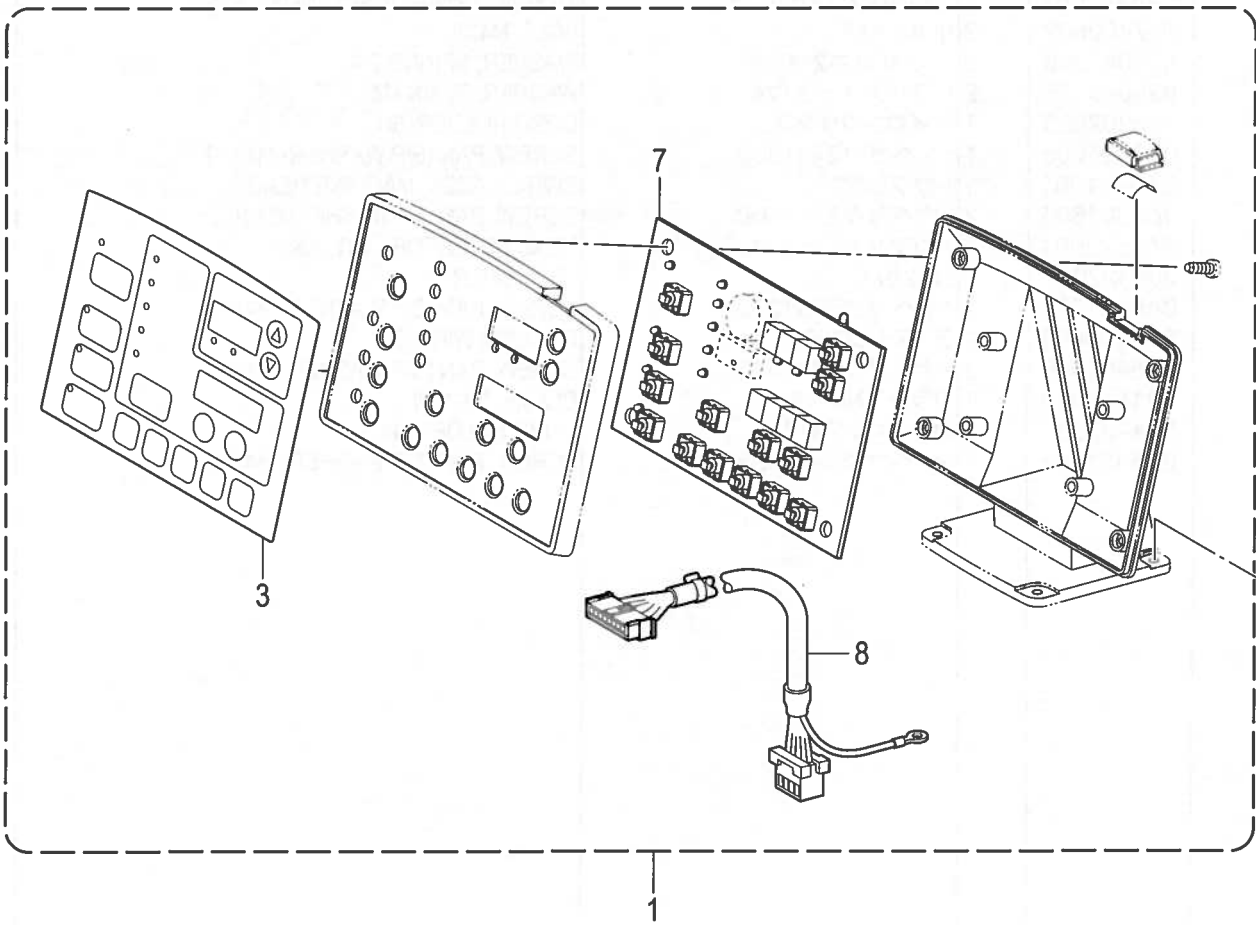

## S. 操作パネル関係 / Operation panel mechanism

REF.NO	CODE	Q'TY	品名	NAME OF PARTS	RM
1	SA3829001	1	ソウサパネルクミ	OPERATION PANEL ASSY	
3	SA3831001	1	ソウサパネルシート	PANEL SHEET	
7	SA3833101	1	パネルキバンクミ	PANEL PCB ASSY	
8	SA3839001	1	パネルハーネス	PANEL HARNESS	
9	0B0452006	4	+マルモク45X20	WOOD SCREW ROUND M4.5X20	

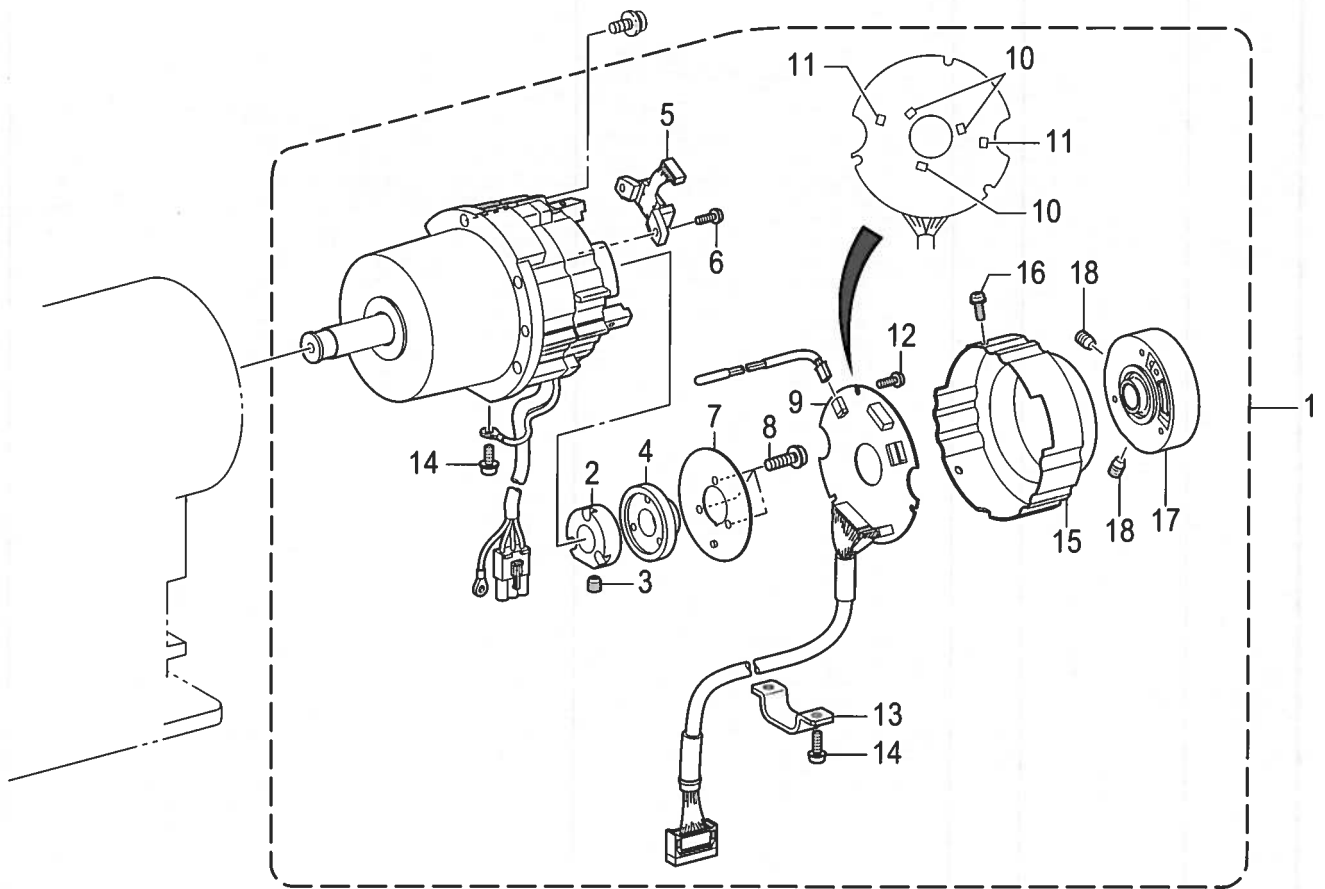

## T. モーター関係 / Motor mechanism

REF.NO	CODE	Q'TY	品名	NAME OF PARTS	RM
1	J80991001	1	モータクミCDD-430D	MOTOR ASSY, CDD-430D	
2	J03955001	1	ドラムコティCDD	DRUM CDD	
3	014400632	1	アナクボミ4X6	SET SCREW, SOCKET (CP) M4X6	
4	J03956001	1	ジシャク180P36	MAGNET 180P36	
5	J03957001	1	MRセンサクミ180P	MR SENSOR ASSY 180P	
6	0A4300805	1	+ナベザクミ3X8DA	SCREW, PAN (S/P WASHER) M3X8	
7	J03958001	1	シヤヘイイタCDD	SHIELD PLATE CDD	
8	0A4261005	3	+ナベザクミ26X10DA	SCREW, PAN (S/P WASHE) M2.6X10	
9	J04488001	1	ENCキバンクミ430D#2	ENC PCB ASSY, 430D#2	
10	J03983001	3	ホ-ルICEW-400	HALL ELEMENT: ICEW-400	
11	J03984001	2	ホ-ルICEW-450	HALL ELEMENT: ICEW-450	
12	0A5300606	3	+ナベザクミ3X6DB	SCREW, PAN (S/P WASHER) M3X6	
13	J04230001	1	コードオサエCDD-HT	CORD HOLDER, CDD-HT	
14	0A4401005	3	+ナベザクミ4X10DA	SCREW, PAN (S/P WASHE) M4X10	
15	J04388001	1	エンコ-ダカバー-430D	ENCODER COVER, 430D	
16	0A4300805	3	+ナベザクミ3X8DA	SCREW, PAN (S/P WASHER) M3X8	
17	J04303001	1	プ-リダイクミ430D	PULLEY HOLDER ASSY, 430D	
18	014500632	2	アナクボミ5X6	SET SCREW, SOCKET (CP) M5X6	

U . 踏板関係 / Foot switch pedal mechanism

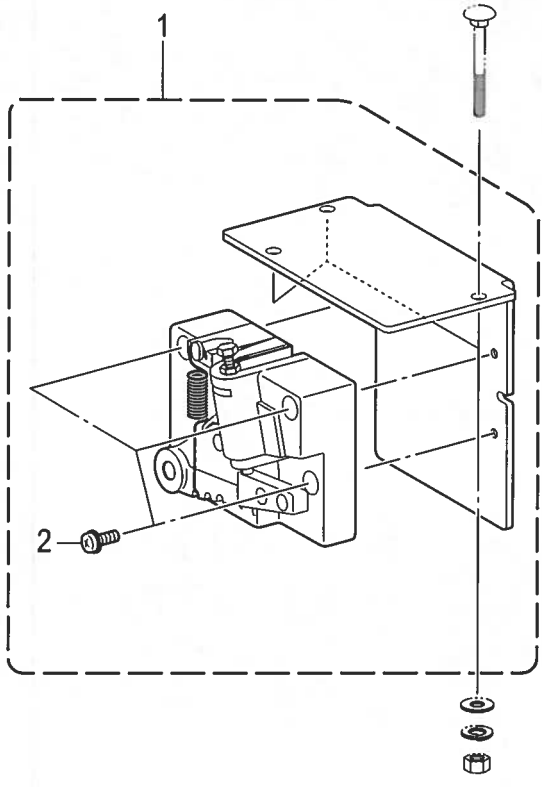

<オプション部品 / Option parts >

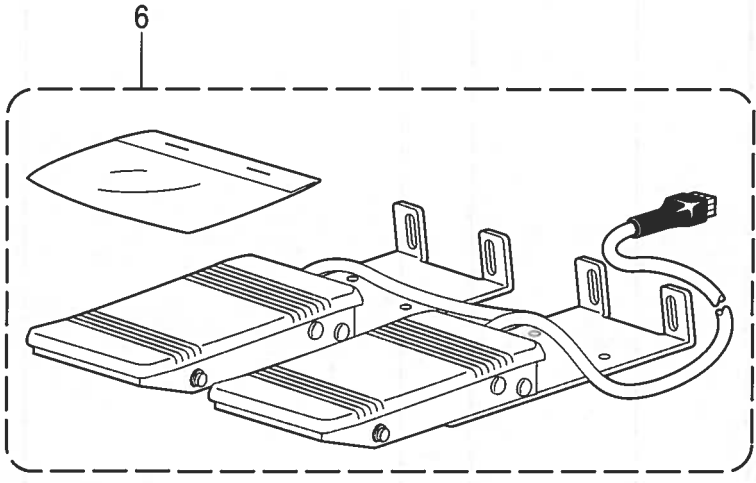
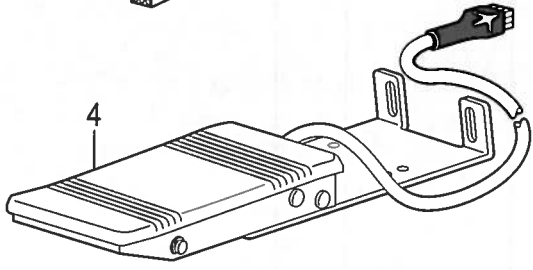
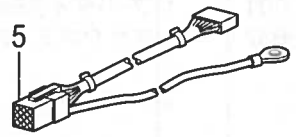

U. 踏板関係 / Foot switch pedal mechanism

REF.NO	CODE	Q'TY	品名	NAME OF PARTS	RM
1	SA3519101	1	フミコムユニットAクミ	TREADLE UINT, A ASSY	
2	0A4501005	3	+ナベザクミ5X10DA	SCREW, PAN (S/P WASHE) M5X10	
			<オプション部品>	<Option parts>	
5	SA3784001	1	フットSWヘンカンハーネス	CONVERSION HARNESS, FOOT SW	
4	S49668101	1	2ダンフットSWクミ	2-STEP FOOT SWITCH ASSY	
6	S51846101	1	2レンフット3SWセット	2-PEDAL FOOT SWITCH SET, 3	

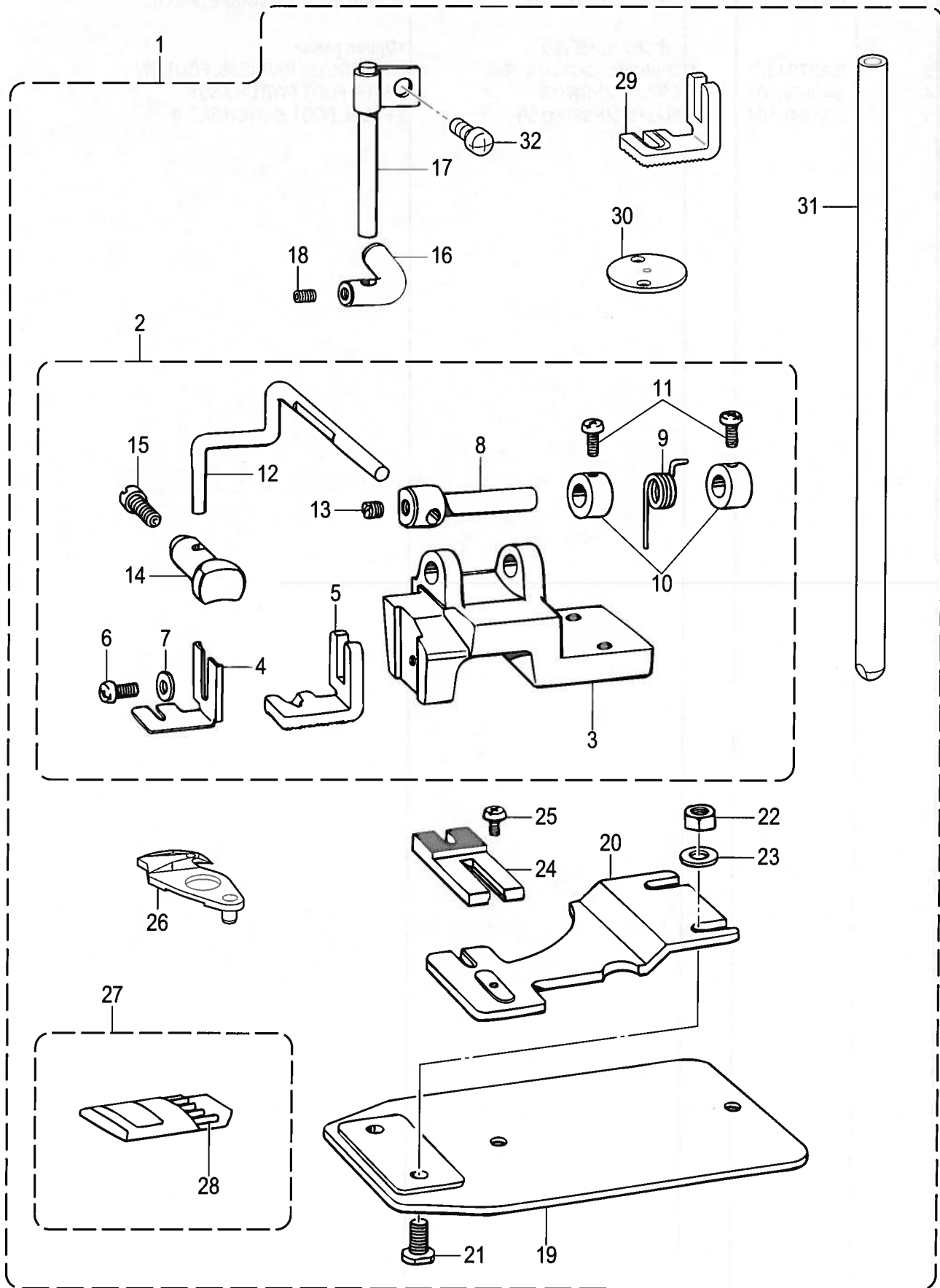



V1. 補助装置関係(BE-438D用オプション部品) / Auxiliary device (Option parts for BE-438D )

REF.NO	CODE	Q'TY	品名	NAME OF PARTS	RM
1	SA6492001	1	シヤンクソウチ438Dクミ	SHANK DEVICE SET 438D	
2	142689309	1	シヤンクボタンツマミタイクミ	SHANK BUTTON CLAMP BRAC. ASSY	
3	154684009	1	シヤンクボタンツマミタイ	SHANK BUTTON CLAMP BRACKET	
4	142677101	1	ボタンツマミA	BUTTON CLAMP, A	
5	142678101	1	ボタンツマミB	BUTTON CLAMP, B	
6	062670812	1	ナベコ357-40X8	SCREW PAN SM3.57-40X8	
7	102707002	1	ザガネ	WASHER	
8	142681001	1	ボタンオサエジク	BUTTON CLAMP STUD	
9	154685001	1	ボタンオサエジクバネ	SPRING	
10	142706001	2	セットカラー	SET SCREW COLLAR	
11	062670712	2	ナベコ357-40X7	SCREW PAN SM3.57-40X7	
12	154686001	1	ボタンオサエウデ	BUTTON CLAMP ARM	
13	013719412	1	トメネジ4.76クボミ	SET SCREW, (CP) SM4.76	
14	142680001	1	ボタンオサエ	BUTTON CLAMP	
15	120990001	1	アタマツキトメネジ4.37	SET SCREW, (CP) SM4.37-40X8	
16	154695001	1	ボタンオサエヒラキ	CLAMP OPENER	
17	154696001	1	ボタンオサエヒラキジク	STUD	
18	014680432	1	アナクボミ437-40X4	SET SCREW SOCKET SM4.37-40X4	
19	154697001	1	オクリイタダイ	FEED PLATE BASE	
20	156336101	1	シヤンクボタンオクリイタ	SHANK BUTTON FEED PLATE	
21	154713001	2	シメネジ4.76	SCREW, SM4.76	
22	021710212	2	2シュナット476-32	NUT 2 SM4.76-32	
23	025710232	2	ヒラザガネチューウ4.76	WASHER PLAIN M SM4.76	
24	142686101	1	ヌノウケダイS	CLOTH RECEIVER, S	
25	060670512	1	バインド357-40X5	SCREW BIND SM3.57-40X5	
26	SA6493001	1	イドウハF-SCLクミ	MOVABLE KNIFE F-SCL ASSY	
27	SA6505014	1	SA6506ハリ10コイリクミ	NEEDLE 10PIECE ASSY SA6506	
28	SA6506014	10	ミシンハリTQX3	NEEDLE TQX3	
29	S03641101	1	ボタンツカミD	BOTTON CLAMP, D	
30	SA3645201	1	ハリアナイタ2.2SC	NEEDLE HOLE PLATE 2.2SC	
31	SA6504001	1	ハリボウB	NEEDLE BAR B	
32	062500616	1	ナベコ5X6	SCREW PAN M5X6	

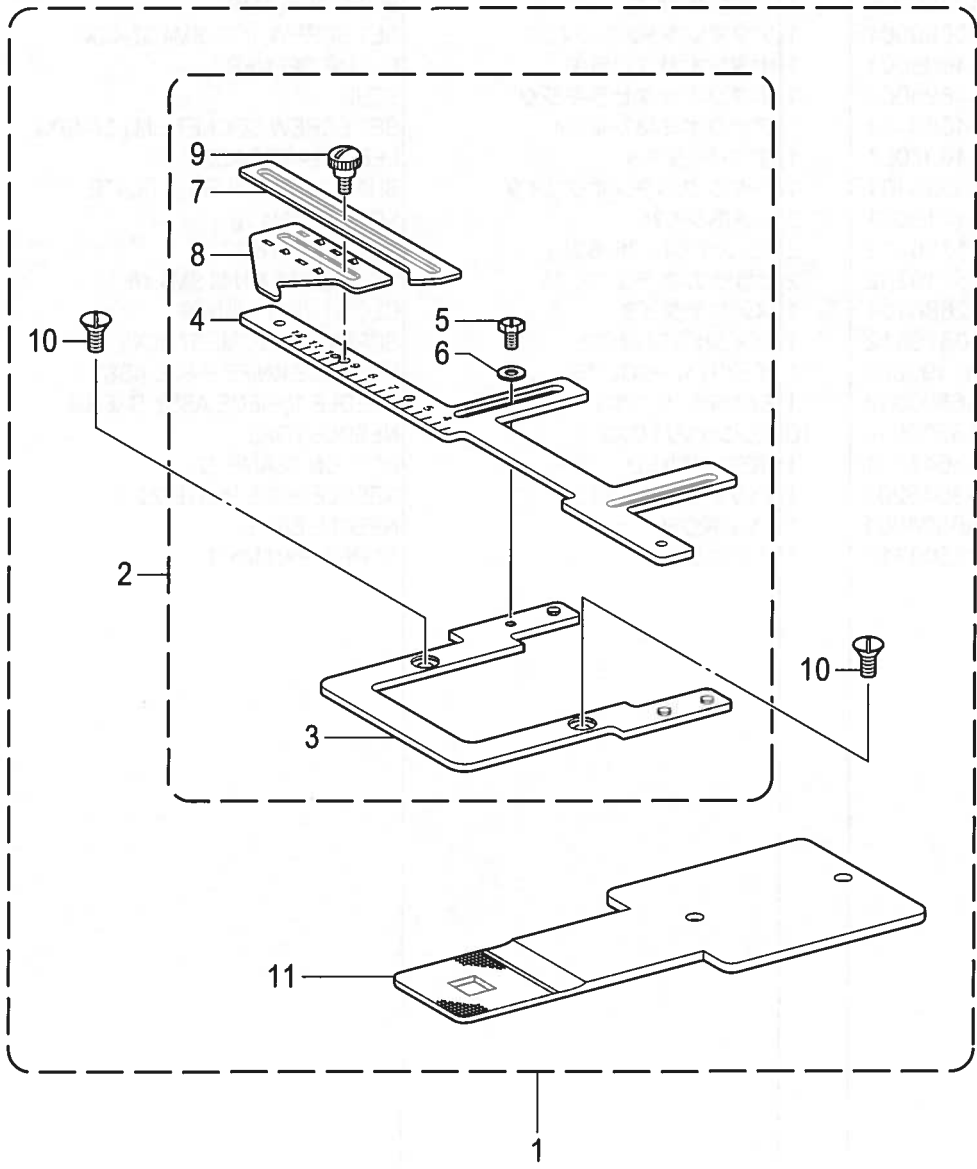

V2. 補助装置関係(BE-438D用オプション部品) / Auxiliary device (Option parts for BE-438D )

REF.NO	CODE	Q'TY	品名	NAME OF PARTS	RM
1	SA6156001	1	ボタンスペーサセット438D	BUTTON SPACER SET 438D	
2	SA6157001	1	ボタンスペーサクミ	BUTTON SPACER ASSY	
3	SA6158001	1	ドダイ	BASE	
4	S09658001	1	スケール	SCALE	
5	S09686001	1	ボルト4.37-40X7	BOLT, SM4.37-40X7	
6	S02745001	1	ザガネ	WASHER	
7	S09659001	1	イチギメイタA	POSITIONING PLATE, A	
8	S09660001	1	イチギメイタB	POSITIONING PLATE, B	
9	115166001	1	ダンネジ4.37	SHOULDER SCREW, SM4.37	
10	S25310101	2	サラネジ4	SCREW, FLAT M4	
11	S13184001	1	スペーサヨウオクリイタ	FEED PLATE	

Z. 付属品関係 / Accessories

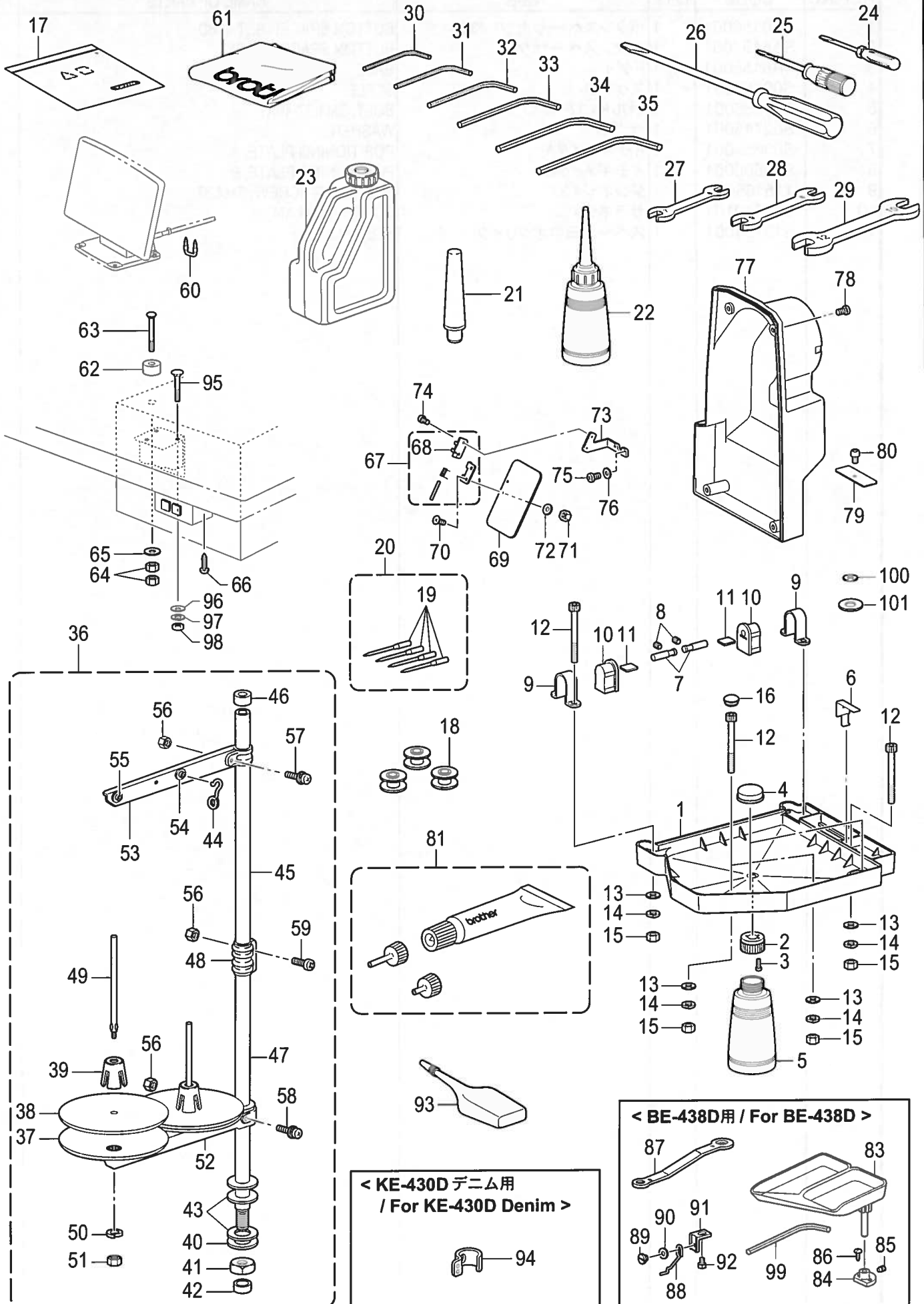

< KE-430D デニム用  
/ For KE-430D Denim >

< BE-438D用 / For BE-438D >

## Z. 付属品関係 / Accessories

REF.NO	CODE	Q'TY	品名	NAME OF PARTS	RM
1	SA3383001	1	オイルパン	OIL PAN	
2	154467001	1	ハイユキヤツブ	DUST OILER	
3	037301215	2	Vナベタツピン3X12	TAPPING SCREW, PAN V M3X12	
4	SA3540001	2	クッションゴム	RUBBER CUSHION	
5	114486002	1	ポリオイラータイ	OILER	
6	SA3820001	1	トウブスイッチバネ	SPRING; HEAD	
7	SA3384001	2	トウブササエピン	PIN	
8	012060636	2	アナヒラ6X6	SET SCREW, SOCKET (FT) M6X6	
9	SA3385001	2	トウブヒンジウケ	HINGE HOLDER	
10	SA3395001	2	トウブヒンジゴム	RUBBER CUSHION	
11	SA3392001	2	スペーサ	SPACER	
12	SA3387001	7	アナボルト6X75	BOLT, SOCKET M6X75	
13	025060336	7	ヒラザガネダイ6	WASHER, PLAIN L 6	
14	028060246	7	バネザガネ2-6	WASHER, SPRING 2-6	
15	021060106	7	1シユナツト6	NUT, 1 M6	
16	S32264001	2	ゴムセン11.5	RUBBER CAP, 11.5	
17	122991001	1	フゾクヒンポリフクロ	ACCESSORY BAG	
18	* P. 53	3	ボビン	BOBBIN	
19	* P. 54	4	ミシンハリ	NEEDLE	
20	* P. 54	1	ハリ4コイリクミ	NEEDLE 4PIECE ASSY	
21	SA3380001	1	マクラ	HEAD REST	
22	114483002	1	ポリオイラークミ	OILER ASSY	
23	S55663001	1	オイルタンククミ	OIL TANK ASSY	
24	142443001	1	ネジマワシ1.9X52	SCREW-DRIVER, 1.9X52	
25	118837001	1	ネジマワシ3.4X70	SCREW-DRIVER, 3.4X70	
26	101572101	1	ネジマワシ5.5X190	SCREW-DRIVER, 5.5X190	
27	107779001	1	スパナ6X7	WRENCH, 6X7	
28	100887001	1	スパナ8X9	WRENCH, 8X9	
29	107780001	1	スパナ10X12	WRENCH, 10X12	
30	S07783001	1	6カクボウスパナ1.5	HEXAGONAL WRENCH, 1.5	
31	142002001	1	6カクボウスパナ2	HEXAGONAL WRENCH, 2	
32	154125001	1	6カクボウスパナ2.5	HEXAGONAL WRENCH, 2.5	
33	142721001	1	6カクボウスパナ3	HEXAGONAL WRENCH, 3	
34	118064001	1	6カクボウスパナ4	HEXAGONAL WRENCH, 4	
35	150335001	1	6カクボウスパナ5	HEXAGONAL WRENCH, 5	
36	S02763502	1	イトタテダイクミ2DR	COTTON STAND ASSY, 2DR	
37	S51283001	2	ウケザラ	SPOOL STAND BASE	
38	150182000	2	スプールのマット	SPOOL MAT	
39	S51282101	2	スプールのクッション	SPOOL CUSHION	
40	150206002	1	ヒラザガネ16	WASHER, PLAIN 16	
41	S38648001	1	6カクナツトU5/8	NUT, U5/8-28	
42	150174000	1	コラムキャツブ	COLUMN CAP	
43	S01005000	2	イトタテゴム	RUBBER WASHER	
44	S02747101	1	イトカケバネ	SPRING	
45	150172003	1	コラムパイプ	COLUMN PIPE	
46	150174000	1	コラムキャツブ	COLUMN CAP	
47	156112003	1	コラムパイプD	COLUMN PIPE, D	
48	150173003	1	コラムジョイント	COLUMN JOINT	
49	150179002	2	スプールのジク	SPOOL SHAFT, B	
50	028050246	2	バネザガネ2-5	WASHER, SPRING 2-5	
51	021500106	2	1シユナツト5	NUT, 1 M5	
52	S02778002	1	スプールのホルダー	SPOOL HOLDER, 2	
53	S02787002	1	スレツドハンガー	THREAD HANGER, 2	
54	150183000	2	イトカケハンガーダイ	THREAD HANGER BASE	
55	142990001	2	スレツドブツシュ	THREAD BUSH	
56	021500106	4	1シユナツト5	NUT, 1 M5	
57	S37038001	1	ナベコヒラザ5X14	SCREW, PAN(S/P WASHER) M5X14	
58	S37037001	1	ナベコヒラザ5X32	SCREW, PAN (S/P WASHER) M5X32	
59	062501406	2	ナベコ5X14	SCREW, PAN M5X14	
60	200190001	7	ステツブル 10X20	STAPLE, 10X20	

Z. 付属品関係 / Accessories

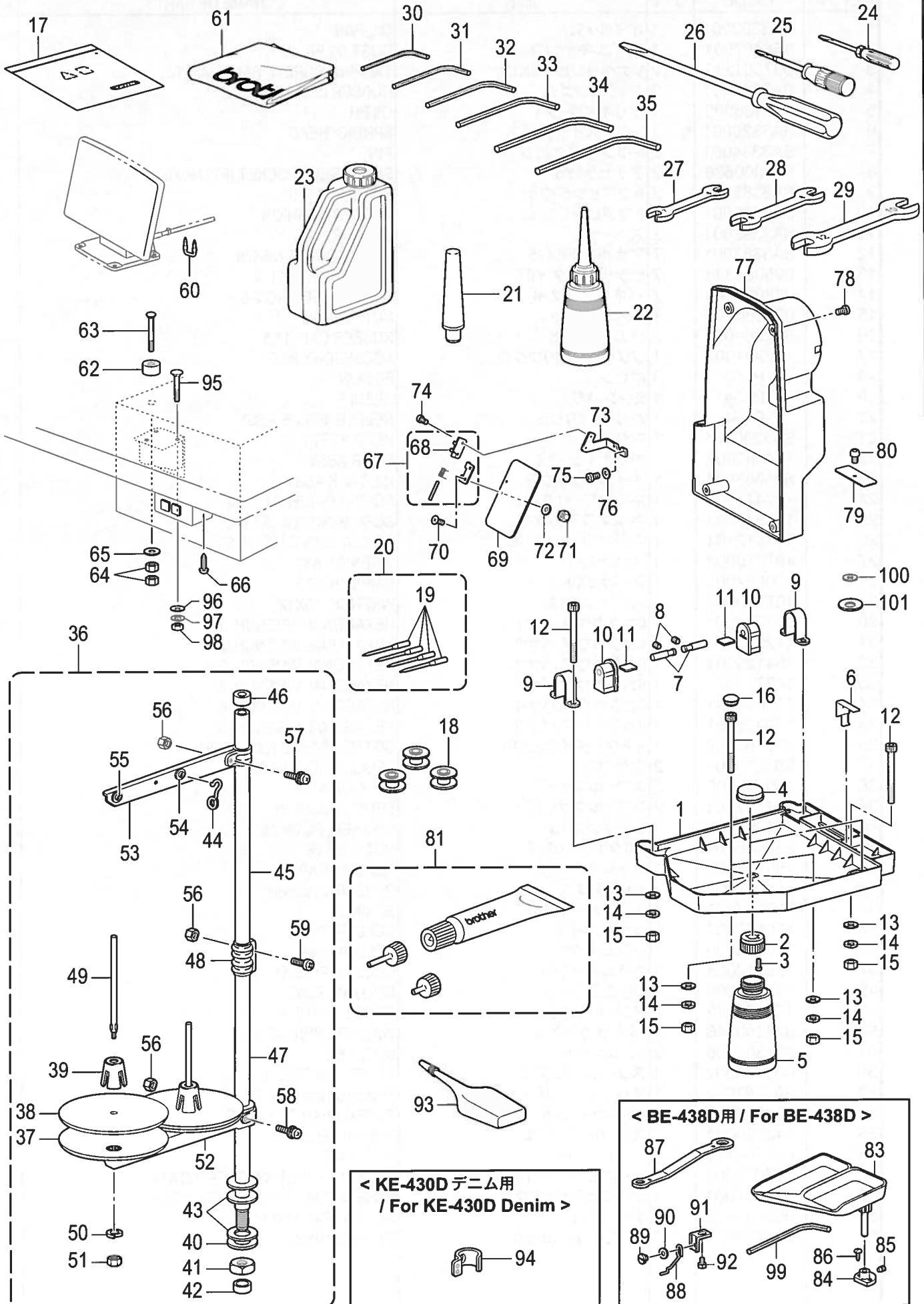

## Z. 付属品関係 / Accessories

REF.NO	CODE	Q'TY	品名	NAME OF PARTS	RM
61	144226001	1	トウブカバー	HEAD COVER	
			<コントロールBox取付用>	<Setting the control box>	
62	S33006001	4	モータスペーサ	MOTOR SPACER	
63	133740006	4	カクネボルト6X70	BOLT, SQUARE M6X70	
64	021060106	8	1シュナツト6	NUT, 1 M6	
65	025060336	4	ヒラザガネダイ6	WASHER, PLAIN L 6	
			<電源SW取付用>	<Setting the power switch>	
66	032461606	2	+2マルモク45X16	WOOD SCREW, ROUND 2 M4.5X16	
67	S44483001	1	チヨウバンクミ	HINGE ASSY	
68	S44484001	1	アイガードヒンジ	EYE GUARD HINGE	
69	S44485001	1	アイガード	EYE GUARD	
70	061300816	2	サラコ3X8	SCREW, FLAT M3X8	
71	021300106	2	1シュナツト3	NUT, 1 M3	
72	026030236	2	ヒラザガネミガキ3	WASHER, PLAIN M 3	
73	SA4104001	1	アイガードホルダ-A	EYE GUARD HOLDER, A	
74	062300506	2	ナベコ3X5	SCREW, PAN M3X5	
75	062400616	2	ナベコ4X6	SCREW, PAN M4X6	
76	026040136	2	ヒラザガネコガタ4	WASHER, PLAIN S 4	
77	SA3388001	1	ウシロカバー	BACK COVER	
78	062061016	4	ナベコ6X10	SCREW, PAN M6X10	
79	SA3489001	1	オクリイタカバー	FEED PLATE COVER	
80	153057101	1	オクリイタシメネジ	SCREW, ROUND W/SOCKET SM4.37	
100	148847001	1	ザガネ	WASHER, PLAIN	
81	SA8771001	1	グリスクミ	GREASE UNIT	
93	S06706001	1	シリコンオイル	SILICONE OIL	
			<BE-438D用>	<For BE-438D>	
83	S18642009	1	ボタンサラ	BUTTON TRAY	
84	153843009	1	ボタンサラアシホルダ	BUTTON TRAY HOLDER	
85	014760632	1	アナクボミ595-28X6	SET SCREW, SOCKET SM5.95-28X6	
86	0B1351606	2	+サラモク35X16	WOOD SCREW, FLAT M3.5X16	
87	105343001	1	メガネレンチ8X9	DOUBLE WRENCH, 8X9	
88	159939001	1	ボタンウカシバネA	SPRING, A	
89	110215002	1	シメネジ3.57	SCREW SM3.57	
90	025660132	1	ヒラザガネショウ3.18	WASER PLAIN S 3.18	
91	159938001	1	ボタンウカシバネササエ	SPRING SUPPORT	
92	146360002	1	ボルト4.76X7	BOLT, SM4.76X7	
99	154179001	1	6カクボウスパナ4(ショートタイプ)	HEXAGONAL WRENCH, 4 (Short type)	
			<KE-430D デニム用>	<For KE-430D Denim>	
94	SA3635101	1	ハリボウイトアンナイB	NEEDLE BAR THREAD GUIDE, B	
			<踏みみユニット取付用>	<Setting the Treadle Unit>	
95	119755001	3	カクネボルト6X60	BOLT, M6X60	
96	025060236	3	ヒラザガネチュウ6	WASHER, PLAIN M 6	
97	028060246	3	バネザガネ2-6	WASHER, SPRING 2-6	
98	021060106	3	1シュナツト6	NUT, 1 M6	
101	SA6397001	1	イドウハカンザ0.2	M-KNIFE SPACER T0.2	
101	SA3334001	1	イドウハカンザ0.3	M-KNIFE SPACER T0.3	
101	SA6398001	1	イドウハカンザ0.4	M-KNIFE SPACER T0.4	

Sp . 仕様別部品一覧表 (KE-430D / BE-438D) / Different parts list (KE-430D / BE-438D)

KE-430D, BE-438Dには下記部品が用意されていますので幅広い用途にご活用ください。











◎表中★の部品は、KE-430C (本縫電子冑止ミシン)、BE-438C (本縫電子ボタン付けミシン) と共通です。

◎表中☆の部品は、BAS-311F (プログラム式電子ミシン) と共通です。

The following are standard gauge parts according to each specification.

◎In the following table, parts marked with ★ are common with the KE-430C (Electronic Lockstitch Tacker) & BE-438C (Electronic Lockstitch Button sewer).

◎In the following table, parts marked with ☆ are common with the BAS-311F (Electronic program Lock Stitcher) .



品名 Part name	仕様 Spec.				BE-438D
	-2	-1	-7	-0F	
(K-61) 針穴板 Needle hole plate 	★ (φ2.4) SA3336-101	(φ2.2) SA3653-201	(φ1.6) SA3652-201	(φ1.6) 入口面取(φ2.6) SA3646-201	(φ1.6) SA6133-001
(F-41) ボビンケース組 Bobbin case assy 	★ 152690-501 < B >	★ 159610-401 < A >	★ 159610-401 < A >	★ 159610-401 < A >	★ 159610-401 < A >
(F-42) ボビンケース 調子ばね Tension spring 	★ 154340-101	★ 154339-101 < A >	★ 154339-101 < A >	★ 154339-101 < A >	★ 154339-101 < A >
(F-43) ボビンケース ばねねじ Screw 	★ 154341-001	★ 154341-001	★ 154341-001	★ 154341-001	★ 154341-001
(F-44) 空転防止ばね Anti-spin spring 	★ SA4315-001 < B >	★ SA4315-001 < A >	★ SA4315-001 < A >	★ SA4315-001 < A >	★ SA4315-001 < A >
(F-45, Z-18) ボビン Bobbin 	★ 159613-051	★ 159613-051	★ 159613-051	★ 159613-051	★ 159613-051
(F-48) 中がま箱組 Shuttle hook assy, w/box 	★ SA1882-001 < B >	★ SA1881-001 < A >	★ SA1881-001 < A >	★ SA1881-001 < A >	★ SA1881-001 < A >
(F-40) 大がま Shuttle race base 	★ 152686-201 < B >	★ 152682-201 < A >	★ 152682-201 < A >	★ 152682-201 < A >	★ 152682-201 < A >
(H-14) 糸調子ばね Spring, tension 	★ 107606-101	★ 104525-101	★ 104525-101	★ 104525-101	★ 104525-101
(H-9) 糸取りばね Thread take-up spring 	★ 144588-301 < B >	★ 145519-301	★ 145519-301	★ 145519-301	★ 145519-301



Sp. 仕様別部品一覧表 (KE-430D / BE-438D) / Different parts list (KE-430D / BE-438D)

◎表中★の部品は、KE-430C (本縫電子罅止ミシン)、BE-438C (本縫電子ボタン付けミシン) と共通です。





◎In the following table, parts marked with ★ are common with the KE-430C (Electronic Lockstitch Tacker) & BE-438C (Electronic Lockstitch Button sewer).

品名 Part name	仕様 Spec.				KE-430D	BE-438D
	-2	-1	-7	-0F		
(H-25, H-24) 針棒糸案内 Needle bar thread guide 	SA3257-101		SA3635-101		SA3635-101	
(Z-20) ミシン針4個入り組 Needle assy	SA1579-019 ★	SA1752-014 ★		SA1737-011	SA1579-012	
(B-34, Z-19) 針 Needle 	DP X 17 NY <#19> S37928-019 ★	DP X 5 <#14> 107415-014 ★	DP X 5 <#9> 107415-009 ★	DP X 5KN <#11> 154763-011	DP X 17NY <#12> S37928-012	

◎標準の押え足、送り板のサイズは、次のとおりです。(実際の縫製エリアは、内枠寸法から約1.5mm内側になります。)

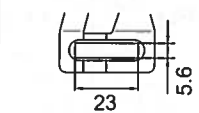
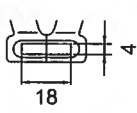
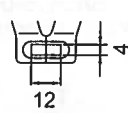
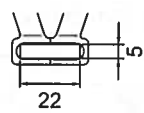
◎Standard sizes for work clamps and feed plates are as follows:

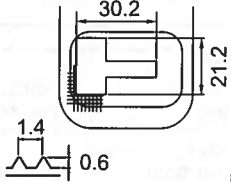
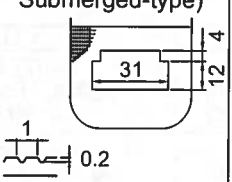
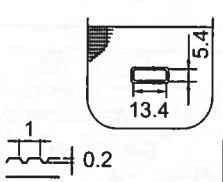
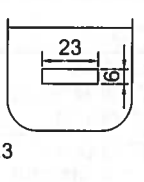
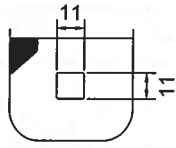
(The actual sewing area has 1.5 mm margin on every size; inside the lines which the dimensions indicate.)

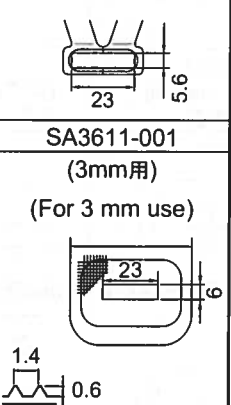
仕様 / Spec.	KE-430D				BE-438D
	-2	-1	-7	-0F	
R L (C-68, 69) 押え足 Work clamp 	153608-101 ★ 154527-001 ★ 	152777-001 ★ 152778-001 ★ 	S49695-001 ★ S49694-001 ★ 	SA6509-001 SA6510-001 	
(C-28) 送り板 Feed plate 	SA3378-001 (3mm用) (For 3 mm use) 	SA3607-001 (2mm用、沈下式) (For 2 mm use, Submerged-type) 	SA3609-001 (2mm用) (For 2 mm use) 	SA6511-201  t = 0.3	SA3606-001 
(C-68, 69) 押え足 Work clamp 	SA3611-001 (3mm用) (For 3 mm use) 				

# Ga. ゲージ部品一覧表 (KE-430D) / Gauge parts list (KE-430D)

<ゲージ部品>

オプションのゲージ部品には次のものがあります。  
 押え足(押え)と送り板は、上下の組合わせになります。

(押え足は KE-430C と共通です。)

< Gauge parts >

The following are provided as optional gauge parts.  
 Each work clamp pair and presser pair are used in combination  
 with the feed plate directly below them.

(Work clamp is common with to the KE-430C.)

	1	2	3	4
R	152781-001 (デニム / For denim)	153201-001 < PL >	153203-001 < PS >	S00906-001 (1 inch)
L	152782-001 (デニム / For denim)	153202-001 < PL >	153204-001 < PS >	S00907-001 (1 inch)
(C-68, 69) 押え足 Work clamp				
(C-28) 送り板 Feed plate	SA3611-001 (デニム / For denim) 	SA3612-001 < PL > 	SA3613-001 < PS > 	SA3614-001 (1 inch) 

	5	6	7	8
R	S33747-001 (30mm)	153201-001 (デニム / For denim)	152777-001 < PM >	152779-001 (メリヤス / For knitted materials)
L	S33748-001 (30 mm)	153202-001 (デニム / For denim)	152778-001 < PM >	152780-001 (メリヤス / For knitted materials)
(C-68, 69) 押え足 Work clamp				
(C-28) 送り板 Feed plate	SA3615-001 (30 mm) 	SA3616-001 (デニム / For denim) 	SA3612-001 (PL) 	SA3608-001 (メリヤス / For knitted materials) 

	9	10	11	12
R	S46771-001 (線門止 / For straight bar tacking)	S46771-001 (線門止・沈 / For straight bar tacking/submerged)	S46774-001 (縦門止 / For vertical bar tacking)	S46774-001 (縦門止・沈 / For vertical bar tacking/submerged)
L	S46770-001 (線門止 / For straight bar tacking)	S46770-001 (線門止・沈 / For straight bar tacking/submerged)	S46773-001 (縦門止 / For vertical bar tacking)	S46773-001 (縦門止・沈 / For vertical bar tacking/submerged)
(C-68, 69) 押え足 Work clamp				
(C-28) 送り板 Feed plate	SA3617-001 (線門止 / For straight bar tacking) 	SA3618-001 (線門止・沈 / For straight bar tacking/submerged) 	SA3619-001 (縦門止 / For vertical bar tacking) 	SA3621-001 (縦門止・沈 / For vertical bar tacking/submerged) 
押え足 Work clamp	156006-001	S59892-001	156006-001	S59892-001
ボルト Bolt				

Ga. ゲージ部品一覧表 (KE-430D) / Gauge parts list (KE-430D)

	13		14		15		16	
R	SA2230-001 (縦門止 / For vertical bar tacking)		SA2233-001 (縦門止 / For vertical bar tacking)		152779-001 (沈下式 S / Submerged -type,S)		152779-001	
L	SA2229-001 (縦門止 / For vertical bar tacking)		SA2232-001 (縦門止 / For vertical bar tacking)		152780-001 (沈下式 S / Submerged -type,S)		152780-001	
(C-68, 69) 押え足 Work clamp								
(C-28) 送り板 Feed plate	SA3620-001 (縦門止 / For vertical bar tacking)		SA3622-001 (縦門止 / For vertical bar tacking)		SA3610-001 (沈下式 S / Submerged -type,S)		SA6346-201	
押え足 Work clamp ボルト Bolt	S59909-001	S59892-001	S59909-001	S59892-001				

	17		18		19	
R	S46777-001 (菊穴 / For circular stitching)		S46780-001 (半月門 / For crescent bar tacking)		SA2236-001 (半月門 / For crescent bar tacking)	
L	S46776-001 (菊穴 / For circular stitching)		S46779-001 (半月門 / For crescent bar tacking)		SA2235-001 (半月門 / For crescent bar tacking)	
(C-68, 69) 押え足 Work clamp						
(C-28) 送り板 Feed plate	SA3623-001 (菊穴 / For circular stitching)		SA3624-001 (半月門 / For crescent bar tacking)		SA3625-001 (半月門 / For crescent bar tacking)	
押え足 Work clamp ボルト Bolt	156006-001	S59892-001	156006-001	S59892-001	S59909-001	S59892-001

Ga. ゲージ部品一覧表 (KE-430D, BE-438D) / Gauge parts list (KE-430D, BE-438D)

	SA3626-001 (菱目有り / With lozenge)	SA3627-001 (菱目有り / With lozenge)
送り板 ブランク Feed plate blank		

(K-61) その他の針穴板 / For other needle hole plate

KE-430D			BE-438D	
SA3645-201	SA3646-201	SA5221-001	SA3654-201	SA7502-001

特注用 (KE-430D) / For specially ordered (KE-430D)





	-1				SA3817-001 (菱目無し / Without lozenge)
R	SA4195-001		S59909-001	S59892-001	
L	SA4196-001				
押え足 ブランク Work clamp blank		押え足 Work clamp			送り板 ブランク Feed plate blank
		ボルト Bolt			

(E) オプション部品 (BE-438D) / Option parts (BE-438D)

ボタンつかみスペーサ / Button clamp spacer

AL	S52071-001 (E-39)	BL	S52072-001 (E-41)	CL	S52073-001 (E-43)	DL	S52074-001 (E-45)
AR	S52075-001 (E-40)	BR	S52076-001 (E-42)	CR	S52077-001 (E-44)	DR	S52078-001 (E-46)

Wa. 警告ラベル / Warning labels

警告ラベル / Warning labels	品名 / Name of parts	Size(mm)	Code
	<p>ラベル感電6ヶ国 Label, elec. shock 6 lang</p>	<p>50 X 118</p>	<p>J04115-001</p>
	<p>ラベル注意・和英 Label, caution Jpn / Eng</p>	<p>64 X 40</p>	<p>SA2040-001</p>
	<p>ラベル注意・中英 Label, caution Chn / Eng</p>	<p>64 X 40</p>	<p>SA2041-001</p>
	<p>アースマーク Label, grounding</p>	<p>φ 12</p>	<p>S37060-001</p>
	<p>PE マーク Label, PE</p>	<p>7.5 X 12.5</p>	<p>S37059-001</p>

## 索引 / Index

CODE	REF.NO	Page	CODE	REF.NO	Page	CODE	REF.NO	Page	CODE	REF.NO	Page
004300513	A -12	2	018061236	N -2	30	028060246	Z -14	50	070608800	C -17	6
011679312	E -16	12		N -16	30		Z -97	52	070688850	D -33	10
012060536	C -45	6	018061636	C -70	8	032461606	Z -66	52	070696800	D -18	10
	D -32	10		D -44	10	037301215	Z -3	50	071031840	C -73	8
	D -38	10	018063036	C -6	6	047250642	E -22	12	081003670	F -18	14
	F -6	14	018063536	C -34	6	047301042	D -27	10	081005070	L -15	26
012060636	B -26	4	018300636	N -24	30	047602042	D -4	10	081007070	M -12	28
	C -8	6	018400836	C -72	8	048040342	K -18	22	0A4261005	T -8	42
	C -13	6		R -4	38		L -14	26	0A4300805	N -19	30
	C -15	6	018401036	C -21	6		L -23	26		T -6	42
	C -19	6		R -2	38		M -7	28		T -16	42
	C -27	6		R -6	38	048050342	J -10	20	0A4401005	T -14	42
	D -13	10	018401636	B -29	4		J -19	20	0A4501005	U -2	44
	D -22	10	018500836	C -48	6	048060342	C -12	6	0A5300606	T -12	42
	D -28	10		C -56	6	048060346	C -43	6	0A5301605	R -25	38
	D -48	10	018501232	F -39	14		D -30	10	0A5401006	R -17	38
	F -9	14		K -40	22	048070342	F -37	14		R -23	38
	F -16	14	018501636	B -3	4		N -9	30		R -27	38
	F -35	14		B -40	4	048080142	C -18	6		R -29	38
	H -28	18	021060106	K -26	22		K -36	22		R -32	38
	K -37	22		K -30	22	048080342	D -11	10	0B0452006	S -9	40
	K -49	22		K -43	22		D -24	10	0B1351606	Z -86	52
	L -2	26		Z -15	50		L -9	26	100136001	H -20	18
	N -10	30		Z -64	52	060400516	K -6	22	100360003	K -62	24
	Z -8	50		Z -98	52	060670512	V1 -25	46	100401021	J -31	20
012300336	B -21	4	021060306	K -28	22	061300816	Z -70	52	100402004	H -17	18
	B -24	4		K -45	22	062060816	G -9	16	100887001	Z -28	50
012400436	F -12	14	021300106	Z -71	52		G -28	16	101572101	Z -26	50
	J -17	20	021400216	D -42	10	062061016	A -6	2	102630001	D -8	10
	J -23	20	021400306	M -4	28		D -50	10	102707002	M -5	28
	K -11	22	021500106	Z -51	50		G -3	16		V1 -7	46
	K -17	22		Z -56	50		J -35	20	104449001	A -8	2
	N -5	30	021710212	V1 -22	46		Z -78	52	104525101	Sp	53
	N -22	30	025030236	A -18	2	062300416	A -17	2	104821001	A -3	2
012500536	B -23	4		K -60	24		B -5	4	105234003	E -8	12
	B -37	4		K -70	24		K -58	24	105343001	Z -87	52
	C -4	6		N -25	30		K -69	24	107415009	Sp	54
	C -46	6	025040236	D -41	10	062300506	Z -74	52	107415014	Sp	54
	C -65	8		L -22	26	062300616	F -25	14	107606101	Sp	53
	D -12	10		R -15	38	062300816	R -8	38	107744001	D -40	10
	D -20	10		R -21	38		R -11	38		E -6	12
	D -25	10	025050134	L -13	26	062350616	J -8	20	107779001	Z -27	50
	F -11	14	025050236	C -50	6	062400616	G -7	16	107780001	Z -29	50
	F -47	14		M -8	28		G -11	16	109239002	A -15	2
	J -3	20	025060236	C -32	6		Z -75	52	110215002	Z -89	52
	J -34	20		C -37	6	062400806	B -39	4	110367001	B -20	4
	L -6	26		C -71	8	062400816	B -41	4		C -42	6
	L -10	26		D -45	10		K -4	22	114483002	Z -22	50
	L -17	26		Z -96	52	062401006	A -20	2	114486002	Z -5	50
013719412	V1 -13	46	025060336	Z -13	50		L -21	26	115147001	E -14	12
014400632	T -3	42		Z -65	52	062401216	J -13	20	115148201	E -13	12
014500632	T -18	42	025660132	Z -90	52	062500616	H -2	18	115156001	E -21	12
014680432	V1 -18	46	025710232	V1 -23	46		H -4	18	115158001	E -26	12
014680632	E -3	12	026030136	F -24	14		H -6	18	115164101	E -33	12
014760632	E -9	12	026030236	Z -72	52		J -29	20	115165001	E -34	12
	Z -85	52	026040136	Z -76	52		V1 -32	46	115166001	E -35	12
017400802	R -13	38	028030246	K -59	24	062501016	A -9	2		V2 -9	48
	R -19	38		R -9	38	062501406	Z -59	50	117608001	A -24	2
017401015	M -3	28	028040246	R -14	38	062670412	H -31	18	117934001	A -2	2
017711412	E -10	12		R -20	38	062670712	V1 -11	46	118064001	Z -34	50
018061236	C -31	6	028050246	C -49	6	062670812	V1 -6	46	118837001	Z -25	50
	C -36	6		K -74	22	062680512	E -25	12	119755001	Z -95	52
	D -35	10		Z -50	50	062680812	E -29	12	120448001	J -22	20

CODE	REF.NO	Page	CODE	REF.NO	Page	CODE	REF.NO	Page	CODE	REF.NO	Page
120990001	V1 - 15	46	152881001	H - 27	18	J03956001	T - 4	42	S25310101	V2 - 10	48
122991001	Z - 17	50	152883000	H - 29	18	J03957001	T - 5	42	S25475001	K - 29	22
133740006	Z - 63	52	152884001	H - 30	18	J03958001	T - 7	42	S28044001	A - 23	2
140392009	A - 1	2	152936001	J - 6	20	J03983001	T - 10	42	S28415000	G - 15	16
	A - 4	2	152937001	J - 7	20	J03984001	T - 11	42	S31032001	H - 12	18
142002001	Z - 31	50	153049001	H - 7	18	J04115001	Wa	58		J - 32	20
142443001	Z - 24	50	153050000	F - 26	14	J04230001	T - 13	42	S32264001	Z - 16	50
142677101	V1 - 4	46		G - 30	16	J04303001	T - 17	42	S32462001	K - 27	22
142678101	V1 - 5	46	153057101	C - 29	6	J04388001	T - 15	42		K - 44	22
142680001	V1 - 14	46		Z - 80	52	J04392001	R - 33	38	S32465001	K - 25	22
142681001	V1 - 8	46	153113001	C - 11	6	J04488001	T - 9	42		K - 42	22
142686101	V1 - 24	46	153201001	Ga	55	J80991001	T - 1	42	S33006001	Z - 62	52
142689309	V1 - 2	46	153202001	Ga	55	S00705001	K - 55	24	S33747001	Ga	55
142706001	V1 - 10	46	153203001	Ga	55	S00906001	Ga	55	S33748001	Ga	55
142721001	Z - 33	50	153204001	Ga	55	S00907001	Ga	55	S37037001	Z - 58	50
142990001	Z - 55	50	153484001	E - 7	12	S01005000	Z - 43	50	S37038001	Z - 57	50
143671000	G - 21	16	153567000	C - 61	8	S01694001	E - 38	12	S37059001	Wa	58
144226001	Z - 61	52	153568001	C - 59	8	S02429201	F - 20	14	S37060001	A - 22	2
144458001	B - 31	4	153596001	N - 8	30	S02652001	K - 13	22		Wa	58
144588301	Sp	53	153608101	Sp	54	S02745001	V2 - 6	48	S37928012	Sp	54
145446001	H - 16	18	153827001	E - 2	12	S02747101	Z - 44	50	S37928019	Sp	54
	H - 22	18	153830000	E - 1	12	S02763502	Z - 36	50	S38033002	L - 18	26
	J - 30	20	153838001	D - 47	10	S02778002	Z - 52	50	S38648001	Z - 41	50
145465001	B - 25	4	153843009	Z - 84	52	S02787002	Z - 53	50	S38713100	B - 38	4
145519301	Sp	53	153922001	G - 17	16	S03468101	E - 30	12	S39690021	K - 9	22
146080000	G - 24	16	154125001	Z - 32	50	S03641101	V1 - 29	46	S42903001	C - 75	8
146202000	R - 22	38	154179001	Z - 99	52	S03657001	E - 31	12	S44483001	Z - 67	52
146352002	K - 75	22	154339101	Sp	53	S03659001	E - 28	12	S44484001	Z - 68	52
146354001	E - 11	12	154340101	Sp	53	S06706001	Z - 93	52	S44485001	Z - 69	52
146354002	C - 55	6	154341001	Sp	53	S07333001	G - 23	16	S44924001	F - 28	14
146360002	Z - 92	52	154467001	Z - 2	50	S07783001	Z - 30	50	S45849000	G - 16	16
146994001	E - 12	12	154527001	Sp	54	S09658001	V2 - 4	48	S46770001	Ga	55
148847001	Z - 100	52	154596000	K - 23	22	S09659001	V2 - 7	48	S46771001	Ga	55
149547000	R - 16	38	154599000	K - 12	22	S09660001	V2 - 8	48	S46773001	Ga	55
150172003	Z - 45	50		M - 2	28	S09686001	V2 - 5	48	S46774001	Ga	55
150173003	Z - 48	50	154684009	V1 - 3	46	S10202201	N - 21	30	S46776001	Ga	56
150174000	Z - 42	50	154685001	V1 - 9	46	S10268001	J - 26	20	S46777001	Ga	56
	Z - 46	50	154686001	V1 - 12	46	S10438001	J - 18	20	S46779001	Ga	56
150179002	Z - 49	50	154695001	V1 - 16	46	S11817000	R - 30	38	S46780001	Ga	56
150182000	Z - 38	50	154696001	V1 - 17	46	S12441001	H - 13	18	S47307001	F - 30	14
150183000	Z - 54	50	154697001	V1 - 19	46		J - 33	20	S48664001	Sp	53
150206002	Z - 40	50	154713001	V1 - 21	46	S12699000	H - 10	18	S49484000	P1 - 31	32
150335001	Z - 35	50	154763011	Sp	54	S13184001	V2 - 11	48	S49668101	U - 4	44
151968001	E - 4	12	155559001	N - 3	30	S15665001	Sp	53	S49694001	Sp	54
151969001	E - 5	12		N - 17	30	S15667001	Sp	53	S49695001	Sp	54
152682201	Sp	53		N - 20	30	S16492101	Sp	53	S49955101	C - 76	8
152684101	F - 23	14	156006001	Ga	55	S18642009	Z - 83	52	S49992000	G - 12	16
152686201	Sp	53		Ga	56	S20356001	D - 10	10	S49998001	E - 15	12
152690501	Sp	53	156112003	Z - 47	50		D - 23	10	S50529000	G - 14	16
152744001	D - 7	10	156336101	V1 - 20	46		L - 8	26	S51282101	Z - 39	50
152777001	Sp	54	159224001	H - 23	18	S20878000	A - 25	2	S51283001	Z - 37	50
	Ga	55	159486001	J - 9	20		A - 26	2	S51846101	U - 6	44
152778001	Sp	54		J - 24	20	S23418002	J - 15	20	S52071001	E - 39	12
	Ga	55	159610401	Sp	53	S23651001	B - 9	4		Ga	57
152779001	Ga	55	159613051	Sp	53		B - 12	4	S52072001	E - 36	12
	Ga	56	159805001	H - 15	18		B - 15	4		E - 41	12
152780001	Ga	55	159938001	Z - 91	52		B - 19	4		Ga	57
	Ga	56	159939001	Z - 88	52		F - 8	14	S52073001	E - 43	12
152781001	Sp	54	200190001	Z - 60	50		J - 37	20		Ga	57
	Ga	55	231071001	K - 20	22		K - 2	22	S52074001	E - 45	12
152782001	Sp	54	554482000	R - 31	38		K - 19	22		Ga	57
	Ga	55	616167001	P2 - 12	34	S25235001	B - 16	4	S52075001	E - 40	12
152788000	C - 60	8	J03955001	T - 2	42	S25310101	K - 72	24		Ga	57

## 索引 / Index

CODE	REF.NO	Page	CODE	REF.NO	Page	CODE	REF.NO	Page	CODE	REF.NO	Page
S52076001	E - 37	12	SA3231001	C - 44	6	SA3317001	K - 32	22	SA3436001	D - 14	10
	E - 42	12		D - 31	10	SA3319101	K - 34	22	SA3437001	D - 15	10
	Ga	57		F - 5	14	SA3320101	K - 38	22	SA3438001	D - 16	10
S52077001	E - 44	12	SA3233001	F - 7	14	SA3321001	K - 39	22	SA3439001	D - 17	10
	Ga	57	SA3234101	F - 10	14	SA3323001	K - 41	22	SA3441001	D - 19	10
S52078001	E - 46	12	SA3237001	F - 13	14	SA3324001	K - 46	22		L - 5	26
	Ga	57	SA3238101	F - 17	14	SA3325001	K - 47	22		L - 16	26
S52093001	E - 18	12	SA3239101	F - 19	14	SA3326001	K - 48	22	SA3442001	D - 21	10
S55663001	Z - 23	50	SA3241001	F - 22	14	SA3327101	K - 50	22	SA3443101	D - 26	10
S56877000	G - 19	16	SA3242001	F - 27	14	SA3333001	K - 77	24	SA3444001	D - 29	10
S59221201	Sp	53	SA3244001	G - 1	16	SA3334001	K - 56	24	SA3445001	D - 34	10
S59315001	E - 17	12	SA3245001	G - 2	16		Z - 101	52	SA3446001	D - 36	10
S59316001	E - 19	12	SA3246001	G - 25	16	SA3336101	Sp	53		L - 11	26
S59317001	E - 20	12	SA3249001	G - 10	16	SA3337001	K - 63	24	SA3447001	L - 1	26
S59318001	E - 23	12	SA3250001	H - 1	18	SA3341001	K - 66	24	SA3448001	L - 3	26
S59319001	E - 24	12	SA3252001	H - 5	18	SA3342001	K - 67	24	SA3449001	L - 4	26
S59320001	E - 27	12	SA3254001	H - 8	18	SA3343001	K - 68	24	SA3451001	L - 7	26
S59321001	E - 32	12	SA3255001	H - 11	18	SA3344001	K - 71	24	SA3452001	L - 12	26
S59886001	F - 32	14	SA3256001	H - 19	18	SA3345001	M - 1	28	SA3458001	L - 19	26
S59892001	Ga	55	SA3257101	H - 25	18	SA3347001	M - 6	28	SA3459101	L - 20	26
	Ga	56		Sp	54	SA3348001	M - 9	28	SA3464001	L - 24	26
	Ga	57	SA3258001	H - 26	18	SA3349001	M - 10	28	SA3465201	R - 1	38
S59909001	Ga	56	SA3260001	A - 5	2	SA3351001	N - 1	30	SA3469201	R - 3	38
	Ga	57	SA3262101	A - 10	2	SA3352101	N - 4	30	SA3472201	R - 5	38
SA1179002	C - 58	8	SA3263001	A - 11	2	SA3353201	N - 6	30	SA3477001	R - 10	38
SA1302001	G - 18	16	SA3264001	A - 13	2	SA3354001	N - 7	30	SA3481001	R - 24	38
SA1579012	Sp	54	SA3265001	A - 14	2	SA3355001	N - 11	30	SA3486001	R - 28	38
SA1579019	Sp	54	SA3266001	A - 16	2	SA3357101	N - 14	30	SA3487001	C - 66	8
SA1737011	Sp	54	SA3273001	F - 15	14	SA3361001	N - 18	30	SA3488001	B - 27	4
SA1752014	Sp	54	SA3274101	F - 29	14	SA3363001	C - 1	6	SA3489001	Z - 79	52
SA1881001	Sp	53	SA3275001	F - 31	14	SA3364001	C - 2	6	SA3497001	B - 17	4
SA1882001	Sp	53	SA3276001	F - 33	14	SA3366001	C - 5	6	SA3499001	B - 2	4
SA1984001	J - 12	20	SA3277001	F - 34	14	SA3367001	C - 9	6	SA3503201	G - 5	16
SA1988001	J - 25	20	SA3278001	F - 36	14	SA3368001	C - 10	6	SA3504201	G - 6	16
SA1994101	J - 38	20	SA3279001	G - 4	16	SA3370001	C - 16	6	SA3519101	U - 1	44
SA2040001	A - 21	2	SA3280001	G - 26	16	SA3371001	C - 20	6	SA3523001	R - 26	38
	Wa	58	SA3282001	G - 8	16	SA3372001	C - 22	6	SA3528001	B - 28	4
SA2041001	A - 21	2	SA3283101	F - 46	14	SA3373001	C - 25	6	SA3533001	C - 3	6
	Wa	58	SA3284001	F - 38	14	SA3378001	Sp	54	SA3534001	C - 26	6
SA2173201	Sp	53	SA3287001	G - 22	16	SA3379001	G - 13	16	SA3538001	C - 23	6
SA2229001	Ga	56	SA3289101	J - 1	20	SA3380001	Z - 21	50		K - 73	24
SA2230001	Ga	56	SA3290001	J - 2	20	SA3381001	C - 30	6	SA3540001	Z - 4	50
SA2232001	Ga	56	SA3291001	J - 4	20	SA3382001	C - 35	6	SA3581001	P1 - 46	32
SA2233001	Ga	56	SA3293001	J - 11	20	SA3383001	Z - 1	50	SA3589001	B - 13	4
SA2235001	Ga	56	SA3294001	J - 14	20	SA3384001	Z - 7	50	SA3591001	B - 17	4
SA2236001	Ga	56	SA3295001	J - 16	20	SA3385001	Z - 9	50	SA3604001	C - 24	6
SA2626001	C - 63	8	SA3296001	J - 20	20	SA3387001	Z - 12	50	SA3606001	Sp	54
SA2958001	B - 22	4	SA3297001	J - 21	20	SA3388001	Z - 77	52	SA3607001	Sp	54
SA3025001	B - 36	4	SA3298001	J - 27	20	SA3392001	Z - 11	50	SA3608001	Ga	55
SA3199001	A - 7	2	SA3299001	J - 28	20	SA3395001	Z - 10	50	SA3609001	Sp	54
SA3200101	A - 19	2	SA3300001	J - 36	20	SA3419101	C - 38	6	SA3610001	Ga	56
SA3201101	B - 1	4	SA3303001	K - 5	22	SA3420001	C - 39	6	SA3611001	Sp	54
SA3206001	B - 6	4	SA3304101	K - 3	22	SA3421001	C - 40	6		Ga	55
	B - 10	4	SA3305001	K - 7	22	SA3422001	C - 41	6	SA3612001	Ga	55
SA3208201	C - 54	6	SA3306001	K - 8	22	SA3423001	C - 47	6	SA3613001	Ga	55
SA3210001	B - 13	4		M - 11	28	SA3424001	C - 51	6	SA3614001	Ga	55
SA3222001	B - 30	4	SA3307001	K - 10	22	SA3425001	C - 52	6	SA3615001	Ga	55
SA3223001	B - 32	4	SA3309001	K - 14	22	SA3426001	C - 53	6	SA3616001	Ga	55
SA3224001	B - 33	4	SA3310001	K - 15	22	SA3427101	C - 57	6	SA3617001	Ga	55
SA3225101	B - 35	4	SA3311001	K - 16	22	SA3428001	C - 64	8	SA3618001	Ga	55
SA3226001	F - 1	14	SA3312201	K - 21	22	SA3432001	D - 3	10	SA3619001	Ga	55
SA3227001	F - 2	14	SA3313101	K - 22	22	SA3434001	D - 6	10	SA3620001	Ga	56
SA3228101	F - 3	14	SA3315001	K - 24	22	SA3435001	D - 9	10	SA3621001	Ga	55



CODE	REF.NO	Page	CODE	REF.NO	Page	CODE	REF.NO	Page	CODE	REF.NO	Page
SA3622001	Ga	56	SA3839001	S - 8	40	SA6492001	V1 - 1	46			
SA3623001	Ga	56	SA4068101	F - 4	14	SA6493001	V1 - 26	46			
SA3624001	Ga	56	SA4072001	D - 49	10	SA6504001	V1 - 31	46			
SA3625001	Ga	56	SA4104001	Z - 73	52	SA6505014	V1 - 27	46			
SA3626001	Ga	57	SA4127001	R - 7	38	SA6506014	V1 - 28	46			
SA3627001	Ga	57	SA4130001	C - 62	8	SA6509001	Sp	54			
SA3628001	D - 5	10	SA4131001	K - 1	22	SA6510001	Sp	54			
SA3629001	D - 39	10	SA4143001	H - 18	18	SA6511201	Sp	54			
SA3630001	D - 43	10	SA4145001	C - 67	8	SA6563001	B - 18	4			
SA3631001	D - 46	10	SA4146001	H - 21	18	SA6596001	K - 53	24			
SA3635101	H - 24	18	SA4171001	J - 5	20	SA6597001	K - 57	24			
	Z - 94	52	SA4172001	B - 4	4	SA7502001	Ga	57			
	Sp	54	SA4173001	B - 4	4	SA8010001	G - 20	16			
SA3645201	V1 - 30	46	SA4174001	B - 4	4	SA8197001	Sp	53			
	Ga	57	SA4175001	B - 4	4	SA8771001	Z - 81	52			
SA3646201	Sp	53	SA4177001	B - 11	4	XC5780001	C - 7	6			
	Ga	57	SA4178001	B - 14	4						
SA3652201	Sp	53	SA4179001	B - 7	4						
SA3653201	Sp	53	SA4180001	B - 8	4						
SA3654201	Ga	57	SA4187001	F - 14	14						
SA3655001	K - 52	22	SA4188001	F - 14	14						
SA3707001	D - 37	10	SA4189001	F - 14	14						
SA3708001	C - 33	6	SA4190001	F - 14	14						
SA3720101	P1 - 17	32	SA4195001	Ga	57						
SA3722001	P1 - 30	32	SA4196001	Ga	57						
SA3724101	P1 - 24	32	SA4197001	C - 14	6						
SA3739501	P1 - 28	32	SA4198001	C - 74	8						
SA3744001	P1 - 29	32	SA4199001	F - 21	14						
SA3755301	P2 - 1	34	SA4221001	G - 27	16						
SA3762001	P2 - 5	34	SA4222001	G - 29	16						
SA3765001	P2 - 2	34	SA4315001	Sp	53						
SA3766001	P2 - 3	34	SA4327001	B - 18	4						
SA3767001	P2 - 4	34	SA4329001	K - 65	24						
SA3768001	P2 - 6	34	SA4330001	K - 64	24						
SA3769001	P2 - 7	34	SA4333001	H - 3	18						
SA3770001	P2 - 8	34	SA4347001	R - 12	38						
SA3771001	P2 - 9	34	SA4348001	R - 18	38						
SA3784001	U - 5	44		K - 51	22						
SA3789101	Q - 11	36	SA4354001	N - 13	30						
SA3794001	P2 - 10	34	SA4461001	N - 12	30						
SA3795001	P2 - 11	34	SA4510101	Q - 12	36						
SA3796001	P1 - 48	32	SA4518001	K - 54	24						
SA3797001	P1 - 22	32	SA4519001	K - 76	24						
SA3806001	P1 - 37	32	SA4545001	K - 35	22						
SA3808101	P1 - 18	32	SA4546001	K - 31	22						
SA3809101	Q - 8	36	SA5137001	N - 23	30						
SA3812001	Q - 7	36	SA5138001	N - 15	30						
SA3813101	Q - 1	36	SA5221001	Ga	57						
SA3816101	Q - 6	36	SA6128001	F - 101	14						
SA3817001	Ga	57	SA6129001	F - 102	14						
SA3819101	Q - 3	36	SA6133001	Sp	53						
SA3820001	Z - 6	50	SA6156001	V2 - 1	48						
SA3822001	Q - 2	36	SA6157001	V2 - 2	48						
SA3823001	Q - 5	36	SA6158001	V2 - 3	48						
SA3824001	Q - 14	36	SA6346201	Ga	56						
SA3825001	Q - 4	36	SA6364001	P1 - 13	32						
SA3826001	Q - 9	36		K - 56	24						
SA3827001	Q - 10	36	SA6397001	Z - 101	52						
SA3828001	Q - 13	36		K - 56	24						
SA3829001	S - 1	40	SA6398001	Z - 101	52						
SA3831001	S - 3	40	SA6429001	K - 53	24						
SA3833101	S - 7	40	SA6431001	K - 57	24						
SA3838101	Q - 15	36	SA6432001	K - 53	24						

# MEMO

# MEMO

brother®

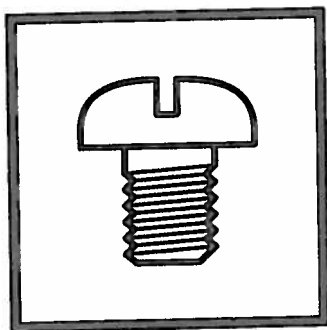

パーツブック  
PARTS BOOK

ブラザー工業株式会社 <http://www.brother.co.jp/>

〒467-8561 名古屋市瑞穂区苗代町 15 番 1 号 TEL : 0120-33-2392

BROTHER INDUSTRIES, LTD. <http://www.brother.com/>

15-1, Naeshiro-cho, Mizuho-ku, Nagoya 467-8561. Japan Phone : 01 52-824-2177



SA3247401  
零件手册

KE-430D, BE-438D  
SA3247-401  
2007.01.B (1)