

KE-484C

パーツブック
PARTS BOOK

全回転3倍釜付本縫電子模様縫ミシン
ELECTRONIC LOCKSTITCH PATTERN TACKER WITH TREBLE HOOK

マニュアルG
速やかに返却して下さい。

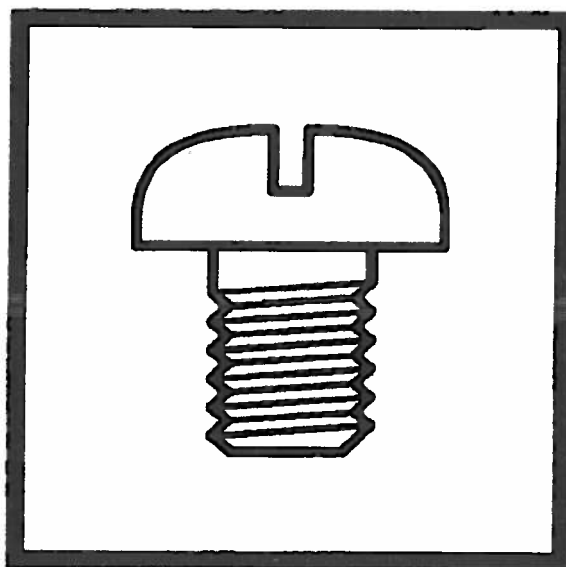

brother®

Notes for using this parts book

- 1 This book was prepared based on information available in October 2002.
- 2 Parts are subject to changes in design without prior notice.
- 3 Parts supplied as complete assemblies are circled by a dotted line .
- 4 If the symbol * is found in the " Parts No." column, refer to the different parts lists, gauge parts list on page 61-62.

CONTENTS

A. Machine body.....	1	Q1. Control box mechanism	35
B1. Upper shaft and needle bar mechanism	3	Q2. Control box mechanism	39
B2. Upper shaft and needle bar mechanism	7	R. Air pressure mechanism.....	43
C1. Feed mechanism.....	9	S. Power supply equipment mechanism.	45
C2. Feed mechanism.....	13	T. Operation panel mechanism	47
D. Presser foot lifter mechanism.....	15	U. Power table	47
E. Thread nipper mechanism	15	V1. Foot switch pedal mechanism	49
F. Rotary hook mechanism.....	17	V2. Foot switch pedal mechanism	
G. Lubrication	19	(Option parts)	51
H. Threading mechanism	21	Z1. Accessories	53
J. Bobbin winder mechanism	23	Z2. Accessories	57
K. Thread trimmer mechanism	25	AA1. Attachment set (Option parts)	59
L. Tension release mechanism	29	Sp. Different Parts list	61
M. Thread take-up mechanism	31	Ga. Gauge parts list	62
N. Synchronizer	33	Wa. Warning labels.....	63
P. Printed circuit board mechanism	33	Index	64

A. 主体関係 / Machine body

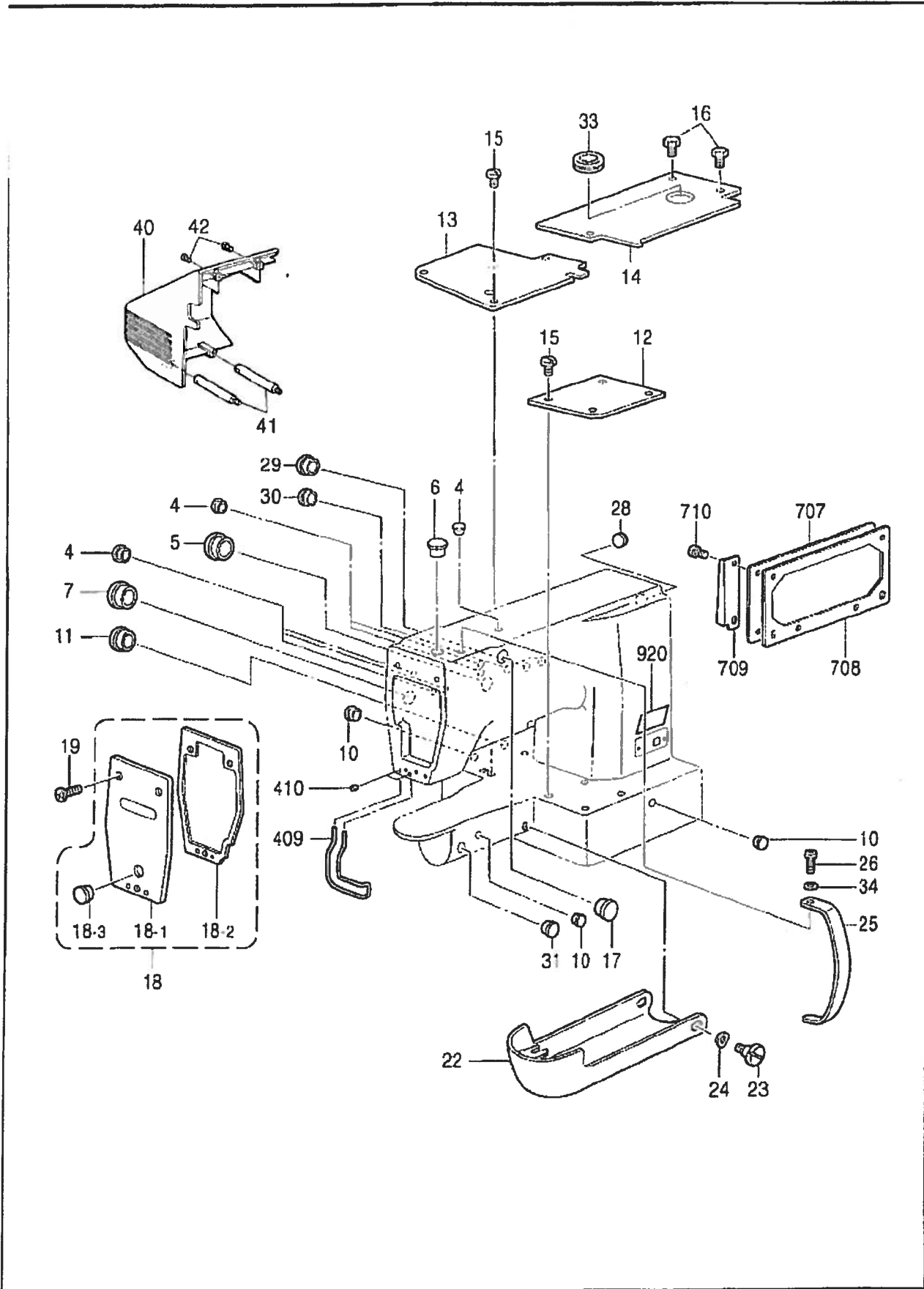

A. 主体関係 / Machine body

REF.NO	CODE	QTY	ヒンメイ	NAME OF PARTS	RM
4	104450101	6	ゴムセン8	RUBBER CAP, 8	
5	140392009	1	オイルワ	OIL CAP	
6	117934001	1	ゴムセン13.5	RUBBER CAP, 13.5	
7	140392009	2	オイルワ	OIL CAP	
10	104450101	3	ゴムセン8	RUBBER CAP, 8	
11	104449001	1	ゴムセン15.5	RUBBER CAP, 15.5	
12	S37915009	1	ベッドカバー-R	BED COVER, R	
13	S53119001	1	ベッドカバー-LF	BED COVER, LF	
14	S53120001	1	ベッドカバー-LR	BED COVER, LR	
15	106629002	9	シメネジ4.37	SCREW, SM4.37	
16	017680512	2	ボルト4.37X5	BOLT, SM4.37X5	
17	S23337001	1	ゴムセン18.5	RUBBER CAP, 18.5	
18	S51457109	1	メンタ433E7ミ	FACE PLATE ASSY, 433E	
18-1	S51458109	1	メンタ433E	FACE PLATE, 433E	
18-2	S49962000	1	メンタパッキン	FACE PLATE PACKING	
18-3	117934001	1	ゴムセン13.5	RUBBER CAP, 13.5	
19	060670812	3	バインド357-40X8	SCREW, BIND SM3.57-40X8	
22	152842059	1	オカマカバー-クミ	SHUTTLE RACE COVER ASSY	
23	145480101	2	ダンネジ6.35	SHOULDER SCREW, SM6.35	
24	109239002	2	ナハネギカネ	WAVE WASHER	
25	S55208000	1	テンヒンカバー	THREAD TAKE-UP LEVER COVER	
26	062681012	1	ナハコ437-40X10	SCREW, PAN SM4.37-40X10	
28	S20164001	1	ゴムセン13	RUBBER CAP, 13	
29	150592001	2	ゴムセン16	RUBBER CAP, 16	
30	104821001	1	ゴムセン10.5	RUBBER CAP, 10.5	
31	S44010001	1	ゴムセン11.5	RUBBER CAP, 11.5	
33	S51460009	1	クロメツトMG-9	RUBBER CAP, MG-9	
40	S51098000	1	ツクメンカバー-IM	FRAME SIDE COVER, IM	
41	S59920001	2	ベルトカバー-シチユウ	BELT COVER SUPPORT PILLAR	
42	062711012	4	ナハコ476-32X10	SCREW, PAN SM4.76-32X10	
409	S53117101	1	フィンガード	FINGER GUARD	
410	011679312	2	トメネジ3.57ヒラ	SET SCREW, (FT) SM3.57	
707	S43907309	1	ツクメンカバー	FRAME SIDE COVER	
708	S41290301	1	OYSTリットケイタパッキン	OYS SETTING PLATE PACKING	
709	S41060109	1	メカクシタ	BLIND PLATE	
710	062710812	4	ナハコ476-32X8	SCREW, PAN SM4.76-32X8	
920	S44629001	1	E7-ク	E-MARK	

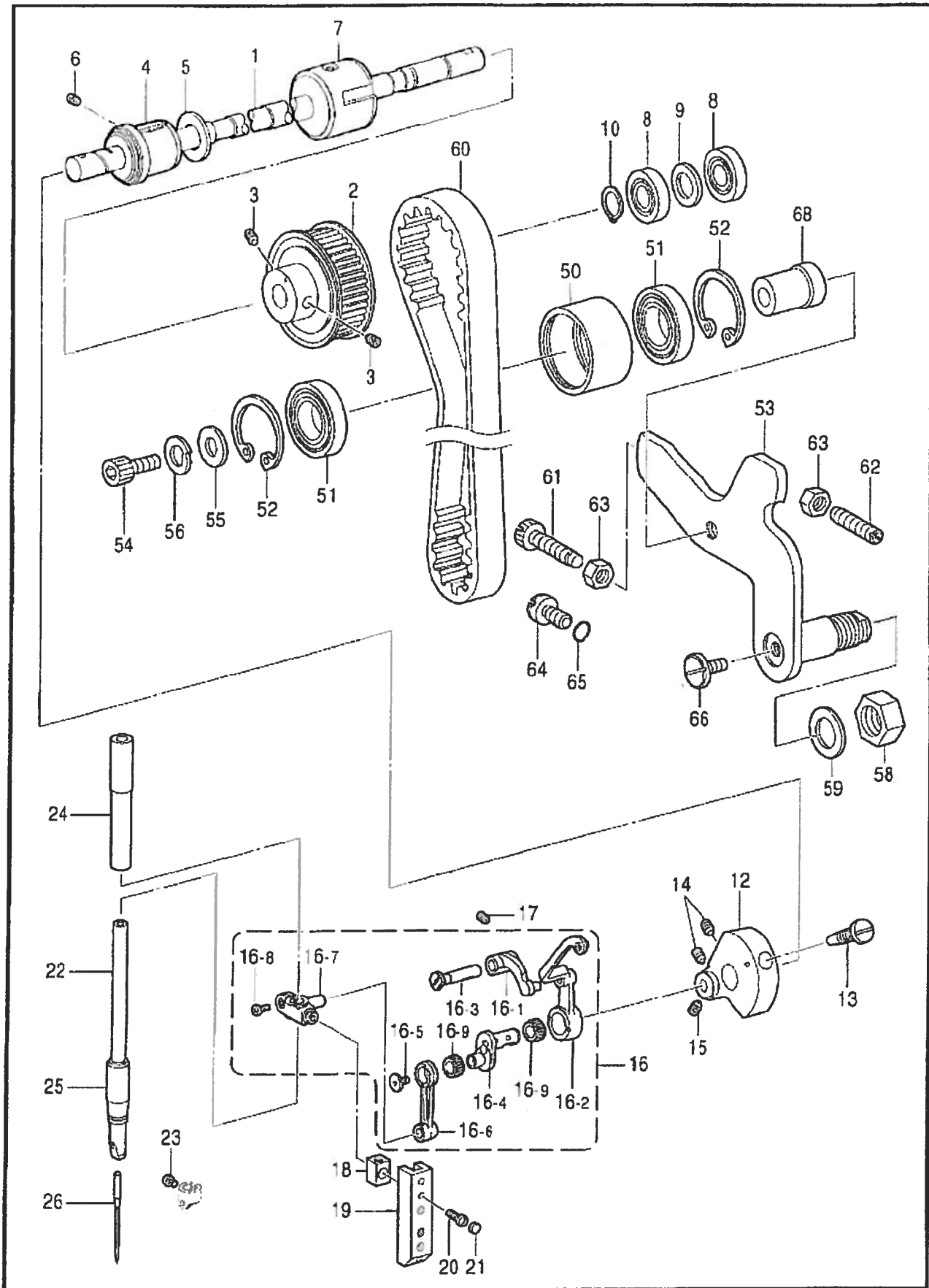

B1. 上軸・針棒関係 / Upper shaft and needle bar mechanism

REF.NO	CODE	QTY	品名	NAME OF PARTS	RM
1	S57632001	1	ウツ 7485	UPPER SHAFT, 485	
2	S57644001	1	UタイミンクプーリーF	U-TIMING PULLEY, F	
3	014770622	2	アトメネジ 6.35クホミ	SET SCREW, SOCKET (CP) SM6.35	
4	S49582001	1	ウツメタルF	UPPER SHAFT BUSH, F	
5	S49583001	1	スラストワッシャー	THRUST WASHER	
6	014780622	1	アトメネジ 6.35クホミ	SET SCREW, SOCKET (CP) SM6.35	
7	140726000	1	ウツメタルM	UPPER SHAFT BUSH, M	
8	072630260	2	ベアリング 6302VV	BALL BEARING, 6302VV	
9	116920001	1	ワッシャー スラストリング	RING, THRUST	
10	048150142	1	保留リング 外部 C15	RETAINING RING, EXTERNAL C15	
12	S57633001	1	スレッドアップクランク 484	THREAD TAKE-UP CRANK, 484	
13	100250001	1	ネジ SM7.14	SCREW, SM7.14	
14	014770622	2	アトメネジ 6.35クホミ	SET SCREW, SOCKET (CP) SM6.35	
15	123006001	1	ネジ SM6.35	SET SCREW, (CP) SM6.35	
16	S57634001	1	ハリネジ クレジット	NEEDLE BAR CONNECTING ROD	
16-1	152233101	1	スレッドアップサポーター	THREAD TAKE-UP SUPPORT	
16-2	S57636001	1	スレッドアップレバー	THREAD TAKE-UP LEVER	
16-3	S47091001	1	スレッドアップサポーターシャフト	THREAD TAKE-UP SUPPORT SHAFT	
16-4	S57637001	1	ハリネジ クランク 484	NEEDLE BAR CRANK	
16-5	145465001	1	ネジ SM3.57L	SCREW, SM3.57-40X6 L	
16-6	S49689001	1	ハリネジ クレジット	NEEDLE BAR CONNECTING ROD	
16-7	S37926101	1	ハリネジ クランプ	NEEDLE BAR CLAMP	
16-8	062680812	1	ネジ SM4.37-40X8	SCREW, PAN SM4.37-40X8	
16-9	147777000	2	ニードルベアリング	NEEDLE BEARING	
			" オプション部品 "	" OPTION PARTS "	
16	S57638001	1	ハリネジ クレジット D	N-BAR CONNECTING ROD ASSY, D	
16-1	S47089001	1	スレッドアップサポーター	THREAD TAKE-UP SUPPORT	
16-2	S57700001	1	スレッドアップレバー, C	THREAD TAKE-UP LEVER, C	
16-3	S47091001	1	スレッドアップサポーターシャフト	THREAD TAKE-UP SUPPORT SHAFT	
16-4	S57637001	1	ハリネジ クランク 484	NEEDLE BAR CRANK	
16-5	145465001	1	ネジ SM3.57L	SCREW, SM3.57-40X6 L	
16-6	S49689001	1	ハリネジ クレジット	NEEDLE BAR CONNECTING ROD	
16-7	S37926101	1	ハリネジ クランプ	NEEDLE BAR CLAMP	
16-8	062680812	1	ネジ SM4.37-40X8	SCREW, PAN SM4.37-40X8	
16-9	147777000	2	ニードルベアリング	NEEDLE BEARING	
17	014780622	1	アトメネジ 6.35クホミ	SET SCREW, SOCKET (CP) SM6.35	
18	102630001	1	ハリネジ アンノイカゴマ	NEEDLE BAR GUIDE SLIDE BLOCK	
19	S49593000	1	ハリネジ アンノイ	NEEDLE BAR GUIDE	
20	100242003	2	ネジ SM3.57	SCREW, SM3.57-40X5	
21	155578000	2	ゴムキャップ 7.2	RUBBER CAP, 7.2	
22	SA2051001	1	ハリネジ ST	NEEDLE BAR, ST	
23	144458001	1	アタマネジ 3.57	SET SCREW, SM3.57-40X4.5	
24	152242001	1	ハリネジ メタル	NEEDLE BAR BUSH, U	
25	152243001	1	ハリネジ メタル D	NEEDLE BAR BUSH, D	
26	145646025	1	針 DPX17	NEEDLE, DPX17	
			" オプション部品 "	" OPTION PARTS "	
26	S24511007	1	針 DPX3355-01MR	NEEDLE, 3355-01 MR	
50	158907001	1	アイドラープーリー	IDLER PULLEY	
51	S35766001	2	ボールベアリング 6202 2RU	BALL BEARING, 6202 2RU	
52	048350242	2	保留リング 内部 C35	RETAINING RING, INTERNAL C35	
53	S57642001	1	テンションプーリーアーム	TENSION PULLEY ARM	
54	018084032	1	ボルト ソケット M8X40	BOLT, SOCKET M8X40	
55	025080232	1	ワッシャー 平 M8	WASHER, PLAIN M8	
56	028080242	1	ワッシャー スプリング 2-8	WASHER, SPRING 2-8	
58	158909001	1	ナット M12.7 (左)	NUT, SM12.7 (LEFT)	
59	025900232	1	ワッシャー 平 M12.70	WASHER, PLAIN M 12.70	
60	S57645001	1	UタイミンクベルトF	U-TIMING BELT, F	

B1 上軸・針棒関係 / Upper shaft and needle bar mechanism

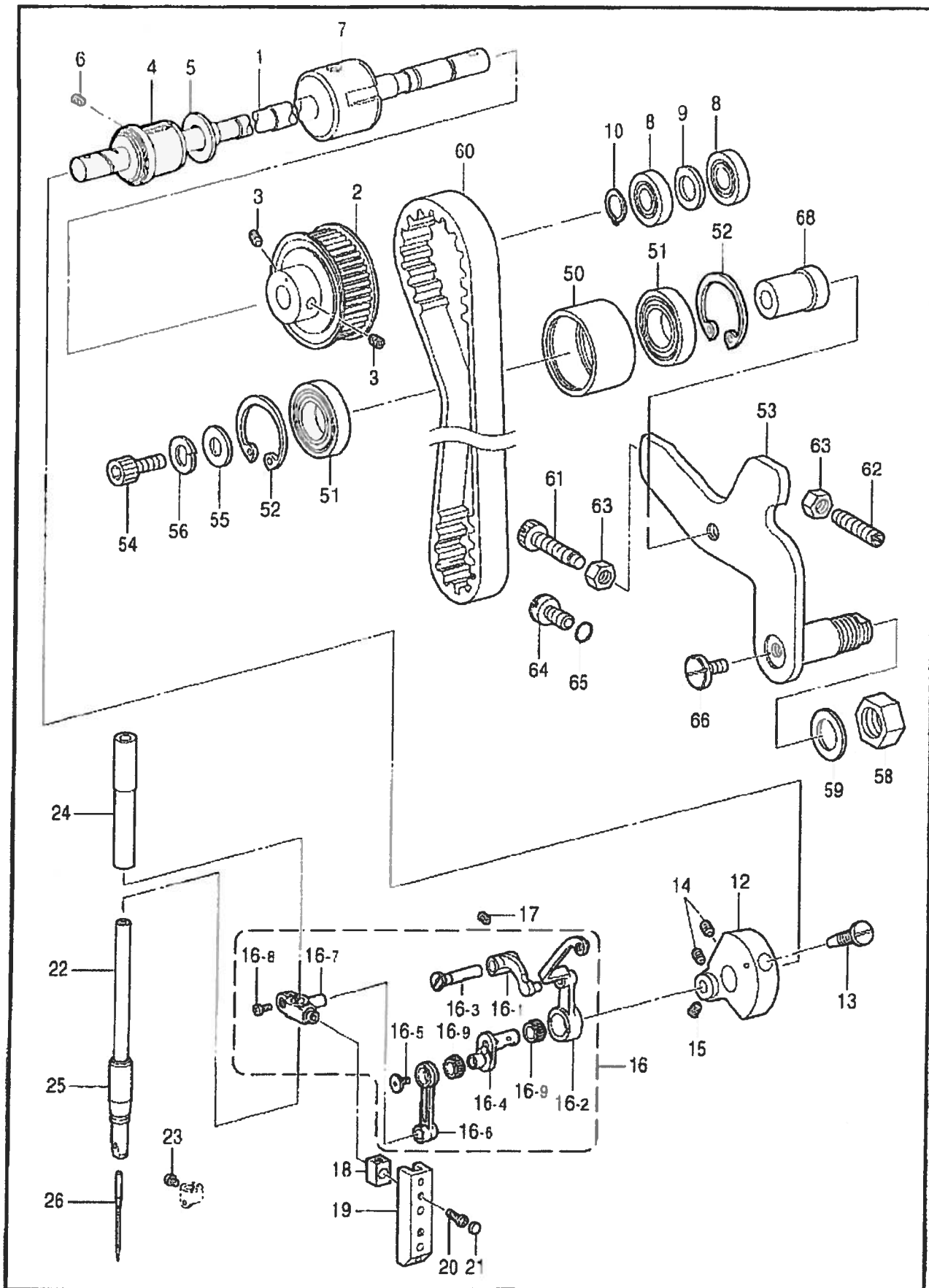

B1. 上軸・針棒関係 / Upper shaft and needle bar mechanism

REF.NO	CODE	QTY	品名	NAME OF PARTS	RM
61	159906001	1	調整ネジ	ADJUSTING SCREW	
62	159905001	1	調整ネジ	ADJUSTING SCREW	
63	105812003	2	ナット 7.94	NUT, SM7.94	
64	140518001	1	ネジ 7.94	SCREW, SM7.94X10	
65	081007070	1	リング P7	O RING, P7	
66	S23618001	1	ネジ 6X10	SCREW, M6X10	
68	SA1087001	1	T7 リスパー	T-PULLEY SPACER	

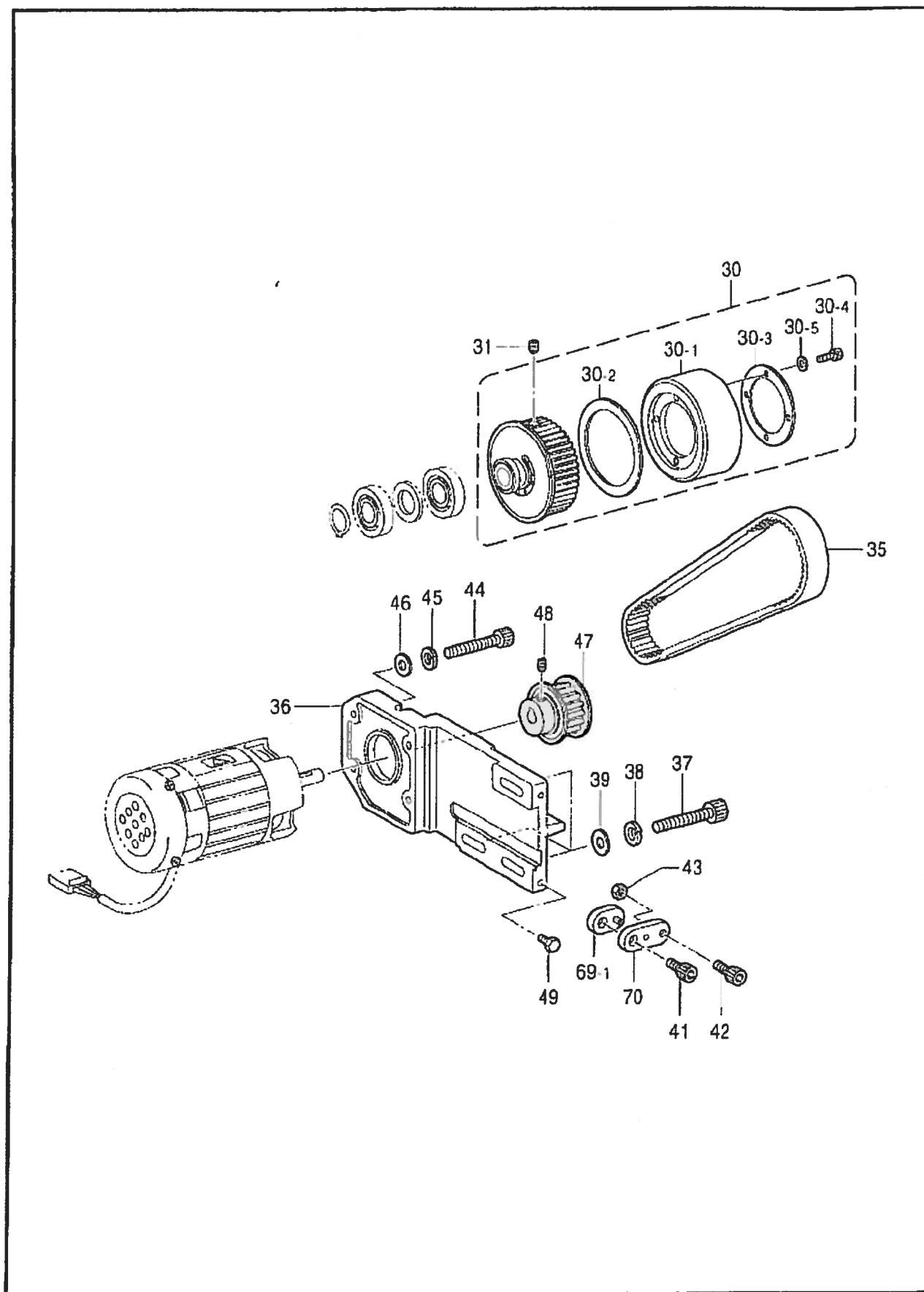

B2. 上軸 - 針棒関係 / Upper shaft and needle bar mechanism

REF.NO	CODE	QTY	品名	NAME OF PARTS	RM
30	S57648001	1	Uタイミングプーリ84ミ	U-TIMINNG PULLEY 84 ASSY	
30-1	S57649001	1	ウツクプーリ84	UPPER SHAFT PULLEY, 84	
30-2	S56018000	1	プーリスパサ	PULLEY SPACER	
30-3	S56019001	1	プーリサカネ	PULLEY WASHER	
30-4	018401236	3	ボルトM4X12	BOLT, SOCKET M4X12	
30-5	028040246	3	ハネサカネ2-4	WASHER, SPRING 2-4	
31	S55572001	2	ボルトM595-28X10	SET SCREW, SOCKET(CP)SM5.95X10	
35	S52838000	1	ウツクタイミングベルト	UPPER SHAFT TIMING BELT	
36	S52839200	1	ME-クワブラケット	MOTOR BRACKET, IM	
37	018083022	3	ボルトM8X30	BOLT, SOCKET M8X30	
38	028080242	3	ハネサカネ2-8	WASHER, SPRING 2-8	
39	025080232	3	ヒラサカネユウ	WASHER, PLAIN M 8	
41	018062022	1	ボルトM6X20	BOLT, SOCKET M6X20	
42	018062522	1	ボルトM6X25	BOLT, SOCKET M6X25	
43	021060102	1	ナットM6	NUT, 1 M6	
44	018063022	4	ボルトM6X30	BOLT, SOCKET M6X30	
45	028060242	4	ハネサカネ2-6	WASHER, SPRING 2-6	
46	025060232	4	ヒラサカネユウ	WASHER, PLAIN M 6	
47	S52836000	1	Mタイミングプーリ32ミ	MOTOR TIMING PULLEY ASSY	
48	S55572001	1	ボルトM595-28X10	SET SCREW, SOCKET(CP)SM5.95X10	
49	017680512	1	ボルト4.37X5	BOLT, SM4.37X5	
69-1	S57976001	1	ベルト調整プレートA	BELT ADJUSTING PLATE A ASSY	
70	S57978001	1	ベルト調整プレートB	BELT ADJUSTING PLATE, B	

C1. 送り関係 / Feed mechanism

REF NO	CODE	QTY	品名	NAME OF PARTS	RM
1	S51857101	1	Xオクリレバ-100ｸﾞﾐ	X-FEED LEVER ASSY, 100	
1-1	S42067101	1	Xオクリレバ-100	X-FEED LEVER, 100	
1-2	S51858001	1	Xオクリレバ-ﾌﾀ	X-FEED LEVER COVER	
1-3	153924001	1	ﾌｪﾙﾄ	FELT	
1-4	108802001	1	ｸﾞﾐﾓ4X4	WICK, 4X4 L=250	
1-5	S37932101	1	ｵｸﾘｶﾑｺﾛ	FEED CAM ROLLER	
1-6	S37933001	1	ｺﾞｼﾞﾝｸﾞ	ROLLER SHAFT	
1-7	014760622	1	ｱﾅﾄﾒﾈｼﾞ5.95	SET SCREW, SOCKET SM5.95	
2	S37934101	1	Xオクリレバ-ﾒﾀﾙ	X-FEED LEVER BUSH	
3	183493001	1	ｵｸﾘｼﾞﾝｸﾞｾｯﾄｶﾗｰｸﾞﾐ	F-SHAFT SET SCREW COLLAR ASSY	
3-1	S09212001	1	ｾｯﾄｶﾗｰ	SET SCREW COLLAR	
3-2	101706001	2	ﾄﾒﾈｼﾞ6.35	SET SCREW, SM6.35-40X5.5	
4	153393001	1	ﾓｺﾞｸﾞﾘﾍﾞ-ｶﾝｻﾞ	WASHER	
5	071047650	1	ｺﾞｷﾞｺﾞ3/16	BEARING BALL, 3/16	
6	014760622	1	ｱﾅﾄﾒﾈｼﾞ5.95	SET SCREW, SOCKET SM5.95	
7	S42069001	1	Yオクリレバ-60ｸﾞﾐ	Y-FEED LEVER ASSY, 60	
7-1	S42070001	1	Yオクリレバ-60	Y-FEED LEVER, 60	
7-2	S37932101	1	ｵｸﾘｶﾑｺﾛ	FEED CAM ROLLER	
7-3	S37933001	1	ｺﾞｼﾞﾝｸﾞ	ROLLER SHAFT	
7-4	014760622	1	ｱﾅﾄﾒﾈｼﾞ5.95	SET SCREW, SOCKET SM5.95	
7-5	152973001	1	ｸﾞﾐﾓ4X4	WICK, 4X4 L=170	
8	152760051	1	ﾀｯｸﾞｸﾞﾘﾍﾞ-ｼﾞｸﾞ	TACK WIDTH FEED LEVER SHAFT	
9	048180142	1	ﾄﾒﾜｼﾞﾝｸﾞｸﾞﾗｲﾄﾞC18	RETAINING RING, EXTERNAL C18	
10	152756001	2	ｽﾄﾗｽﾄﾞｷﾞﾝｸﾞｶﾞﾈ18	WASHER, THRUST 18	
11	014760622	1	ｱﾅﾄﾒﾈｼﾞ5.95	SET SCREW, SOCKET SM5.95	
12	S41703000	1	PMﾌﾞﾗｯकेｯﾄX	PM BRACKET, X	
13	S53099001	1	ｵｸﾘｶﾑX100	X-FEED CAM, 100	
14	014760622	2	ｱﾅﾄﾒﾈｼﾞ5.95	SET SCREW, SOCKET SM5.95	
15	S41705001	1	ｶﾞｼﾞﾝｸﾞX	CAM SHAFT, X	
16	070688850	3	ｸﾞﾗﾝﾄﾞｸﾞﾗｲﾄﾞ688ZZNR	BALL BEARING, 688ZZNR	
17	S51099000	1	PMﾌﾞﾗｯケｯﾄY	PM BRACKET, Y	
18	S51100001	1	ｵｸﾘｶﾑYﾌﾞﾗｯケｯﾄY60	Y-FEED CAM BRACKET, 60	
19	S53100001	1	ｵｸﾘｶﾑY60	Y-FEED CAM, 60	
20	014760622	2	ｱﾅﾄﾒﾈｼﾞ5.95	SET SCREW, SOCKET SM5.95	
21	S51101001	1	ｶﾞｼﾞﾝｸﾞY	CAM SHAFT, Y	
22	070688850	2	ｸﾞﾗﾝﾄﾞｸﾞﾗｲﾄﾞ688ZZNR	BALL BEARING, 688ZZNR	
23	S37940001	2	ｲﾝﾃﾞｯｷﾝｸﾞ	POSITIONING PIN	
24	062681012	2	ﾊﾞﾝﾄﾞ3437-40X10	SCREW, PAN SM4.37-40X10	
25	S51103001	1	ｾｯﾄｶﾗｰ	SET SCREW COLLAR	
26	014760622	2	ｱﾅﾄﾒﾈｼﾞ5.95	SET SCREW, SOCKET SM5.95	
27	S37942100	4	ｶｯﾌﾟﾘﾝｸﾞﾊﾌﾞ8	COUPLING HUB, 8	
28	S37944000	2	ｶｯﾌﾟﾘﾝｸﾞｽﾊﾟｰｻ	COUPLING SPACER	
29	014760622	8	ｱﾅﾄﾒﾈｼﾞ5.95	SET SCREW, SOCKET SM5.95	
30	S51462001	1	ｸﾞｰﾝﾍﾞﾝﾄﾞｸﾞX	HOME POSITION DOG, X	
31	S51463001	1	ｸﾞｰﾝﾍﾞﾝﾄﾞｸﾞY	HOME POSITION DOG, Y	
32	060680712	2	ﾊﾞﾝﾄﾞ437-40X7	SCREW, BIND SM4.37-40X7	
33	S53108001	1	Xｾﾝｻｰﾄﾘｯｼﾞﾌﾟﾚｰﾄ	X-SENSOR SETTING PLATE	
34	018400632	1	ｱﾅﾙﾄ4X6	BOLT, SOCKET M4X6	
35	025040232	1	ﾌﾟﾗｲﾝM4	WASHER, PLAIN M 4	
36	S53109001	1	Xｾﾝｻｰﾄﾘｯｼﾞﾌﾟﾚｰﾄ	X-SENSOR SETTING BASE	
37	S51465001	1	Yｾﾝｻｰﾄﾘｯｼﾞﾌﾟﾚｰﾄ	Y-SENSOR SETTING PLATE	
38	062680612	1	ﾊﾞﾝﾄﾞ34.37-40X6	SCREW, PAN SM4.37-40X6	
41	S42083001	1	ﾌೀﾄﾞﾌﾞﾗｯकेｯﾄ	FEED BRACKET GUIDE PLATE, R	
42	145318001	2	ﾌೀﾄﾞ4.37	SCREW, SM4.37	
43	100032004	2	ﾌೀﾄﾞ4.37	SCREW, FLAT SM4.37-40X8	
44	S42084101	1	ﾌೀﾄﾞﾌﾞﾗｯकेｯﾄ	FEED BRACKET ASSY	
44-1	156076101	1	ﾌೀﾄﾞﾌﾞﾗｯकेｯﾄ	FEED BRACKET	
44-2	153377001	2	ﾛｰﾗｰA3X17.8	ROLLER, A 3X17.8	
44-3	153378001	2	ﾌೀﾄﾞﾌﾞﾗｯケｯﾄ	FEED GUIDE ROLLER	
44-4	148133001	2	ﾛｰﾗｰ	ROLLER	
44-5	156108001	1	ﾀｲﾌﾟWﾌೀﾄﾞレギュレーター	T-WIDTH REGULATOR BLOCK ASSY	

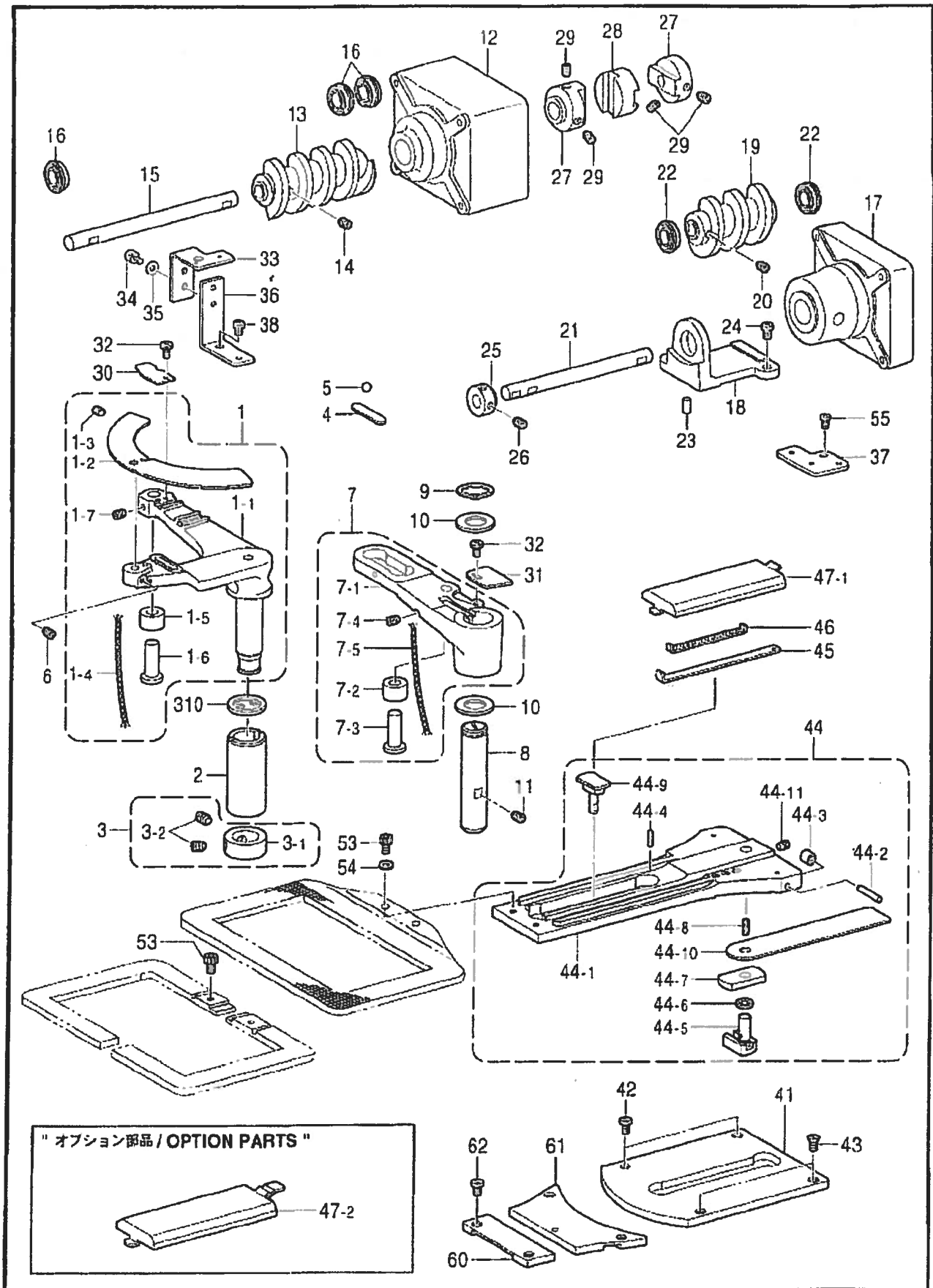

C1. 送り関係 / Feed mechanism

REF.NO	CODE	QTY	品名	NAME OF PARTS	RM
44-6	156109001	1	カンサ	SPACER	
44-7	156077001	1	オクリカ イカコ	FEED GUIDE SLIDE BLOCK	
44-8	156080000	1	フェルト	FELT	
44-9	153380001	1	ヨコオクリカコマ	T-LENGTH REGULATOR BLOCK ASSY	
44-10	S42086001	1	Yオクリカレバ	Y-FEED LEVER COVER	
44-11	014760622	1	アトメネン 5.95	SET SCREW, SOCKET SM5.95	
45	153383001	2	オクリカ イカンサ	SPACER	
46	153384001	2	リテ	RETAINER ASSY	
47-1	153391001	1	オクリカ イカ	FEED BRACKET COVER, L	
			" オプション部品 "	" OPTION PARTS "	
47-2	S51860001	1	オクリカ イカ LL	FEED BRACKET COVER ASSY, LL	
53	S59892001	4	アホ #4.37X5	BOLT, SOCKET SM4.37X5	
54	025680232	2	ヒラガ 4.37	WASHER, PLAIN M 4.37	
55	062670612	1	ネジ 357-40X6	SCREW, PAN SM3.57-40X6	
60	SA1054001	1	オクリカ イカ	FEED BAR GUIDE PLATE, FF	
61	SA1055001	1	オクリカ イカ	FEED BAR GUIDE PLATE, FR	
62	145318001	4	メネン 4.37	SCREW, SM4.37	
310	SA2210001	1	Xオクリカ	X-FEED LEVER FELT	

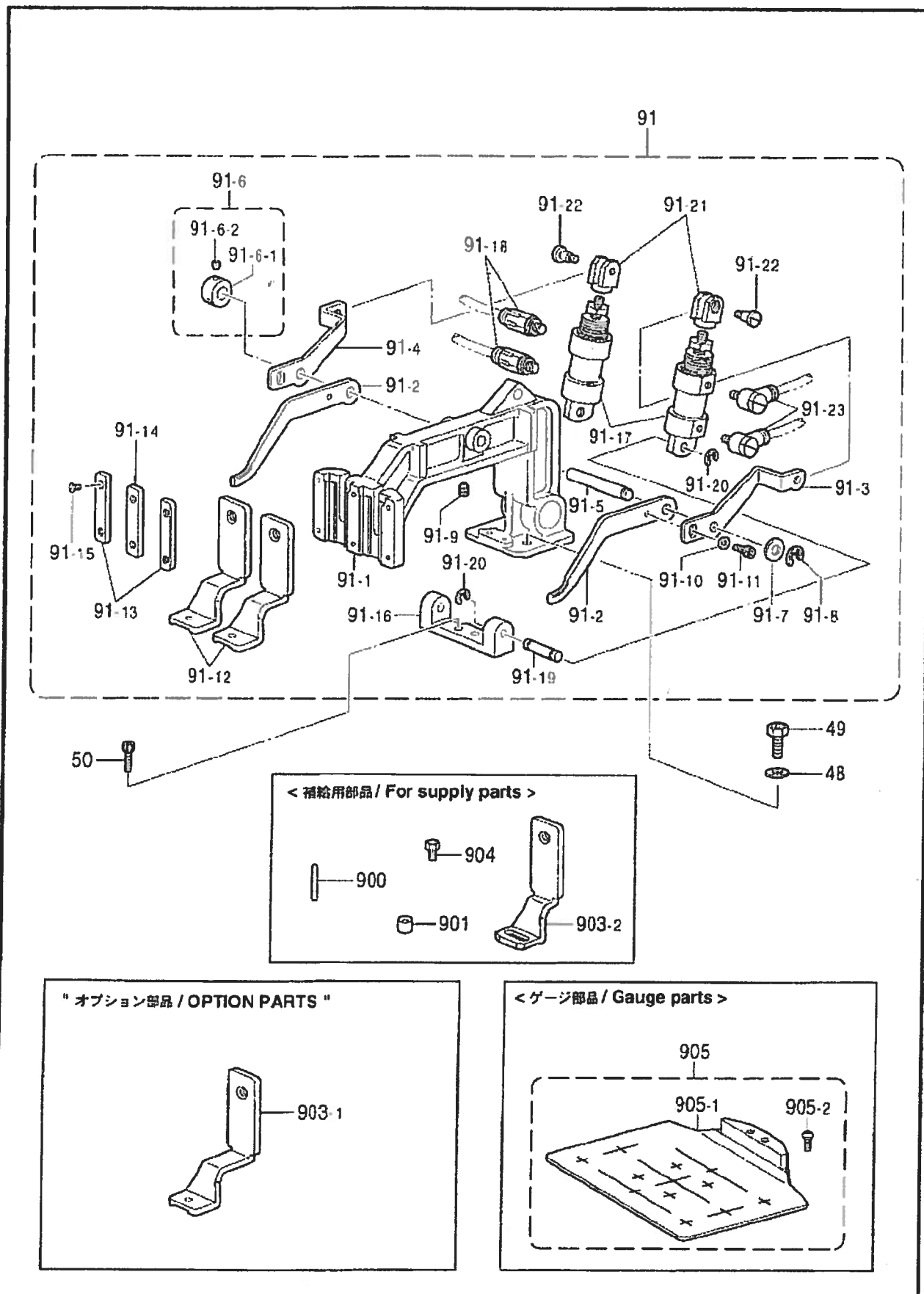

C2. 送り関係 / Feed mechanism

REF.NO	CODE	QTY	ヒンメイ	NAME OF PARTS	RM
48	025060232	2	ヒラサカネジM6	WASHER, PLAIN M 6	
49	S39110001	2	ボルト5.95-28X14	BOLT, W/SOCKET SM5.95-28X14	
50	018501022	2	ボルトM5X10	BOLT, SOCKET M5X10	
91	S53091001	1	オサエウデクミ434E17-	WORK CLAMP ARM ASSY, 434E PNEU	
91-1	S41658000	1	オサエウデZ34IP-	WORK CLAMP ARM, Z34 PNEUMATIC	
91-2	S53092001	2	オサエウデレバ-F	WORK CLAMP ARM LEVER, F	
91-3	S10377101	1	オサエウデレバ-RR	WORK CLAMP ARM LEVER, RR	
91-4	S10378101	1	オサエウデレバ-RL	WORK CLAMP ARM LEVER, RL	
91-5	S10058001	1	オサエウデレバ-シク	W-CLAMP ARM LEVER SHAFT	
91-6	S21775001	1	セツカク-	SET SCREW COLLAR ASSY	
91-6-1	139096001	1	セツカク-	SET SCREW COLLAR	
91-6-2	014680622	2	アトメネジ 4.377M5	SET SCREW, SOCKET (CP) SM4.37	
91-7	143591001	1	スラストリング	THRUST RING	
91-8	048050342	1	トメE5	RETAINING RING, E5	
91-9	014760622	1	アトメネジ 5.95	SET SCREW, SOCKET SM5.95	
91-10	025040232	2	ヒラサカネジM4	WASHER, PLAIN M 4	
91-11	018400622	2	ボルトM4X6	BOLT, SOCKET M4X6	
91-12	S41660001	2	オサエウデ434EIP-	WORK CLAMP, 434E PNUMATIC	
91-13	153369001	2	オサエウデガイドA	WORK CLAMP GUIDE PLATE, A	
91-14	153370001	1	オサエウデガイドB	WORK CLAMP GUIDE PLATE, B	
91-15	107038003	6	ボルト 3.57	SCREW, FLAT SM3.57	
91-16	S53094001	1	シリンダ サリ	CYLINDER SUPPORT	
91-17	S53095000	2	エアシリンダ 15-18	AIR CYLINDER, 15-18	
91-18	S18415101	2	ハーフユニオンQ4M5	HALF UNION, Q4M5	
91-19	S03800001	2	クレビスピン	CLEVIS PIN	
91-20	048040342	4	トメE4	RETAINING RING, E4	
91-21	S53096001	2	シリンダ ツキテ	CYLINDER JOINT	
91-22	110168001	2	ロッド	ROLLER SHAFT	
91-23	S41271000	2	エルボ M5	ELBOW, M5	
			" オプション部品 "	" OPTION PARTS "	
903-1	S51102001	1	オサエウデ434EMK2IP-	WORK CLAMP, 434EMK2 AIR	
			" 補給用部品 "	" For supply parts "	
900	153377001	1	ローラ A3X17.8	ROLLER, A 3X17.8	
901	153378001	1	オクリガイコロ	FEED GUIDE ROLLER	
903-2	S12685001	1	オサエウデ LH	WORK CLAMP, LH	
904	153403002	2	ボルト 4.37X7	BOLT, SM4.37X7	
			" ゲージ部品 "	" GAUGE PARTS "	
905	S54984001	1	ゲージクミ434EMK2	GAUGE ASSY, 434EMK2	
905-1	S52100001	1	ホームポジションユニット	HOME POSITION STANDARD PLATE	
905-2	S49955001	2	オクリガイネジ	SCREW, W/SOCKET SM4.37	

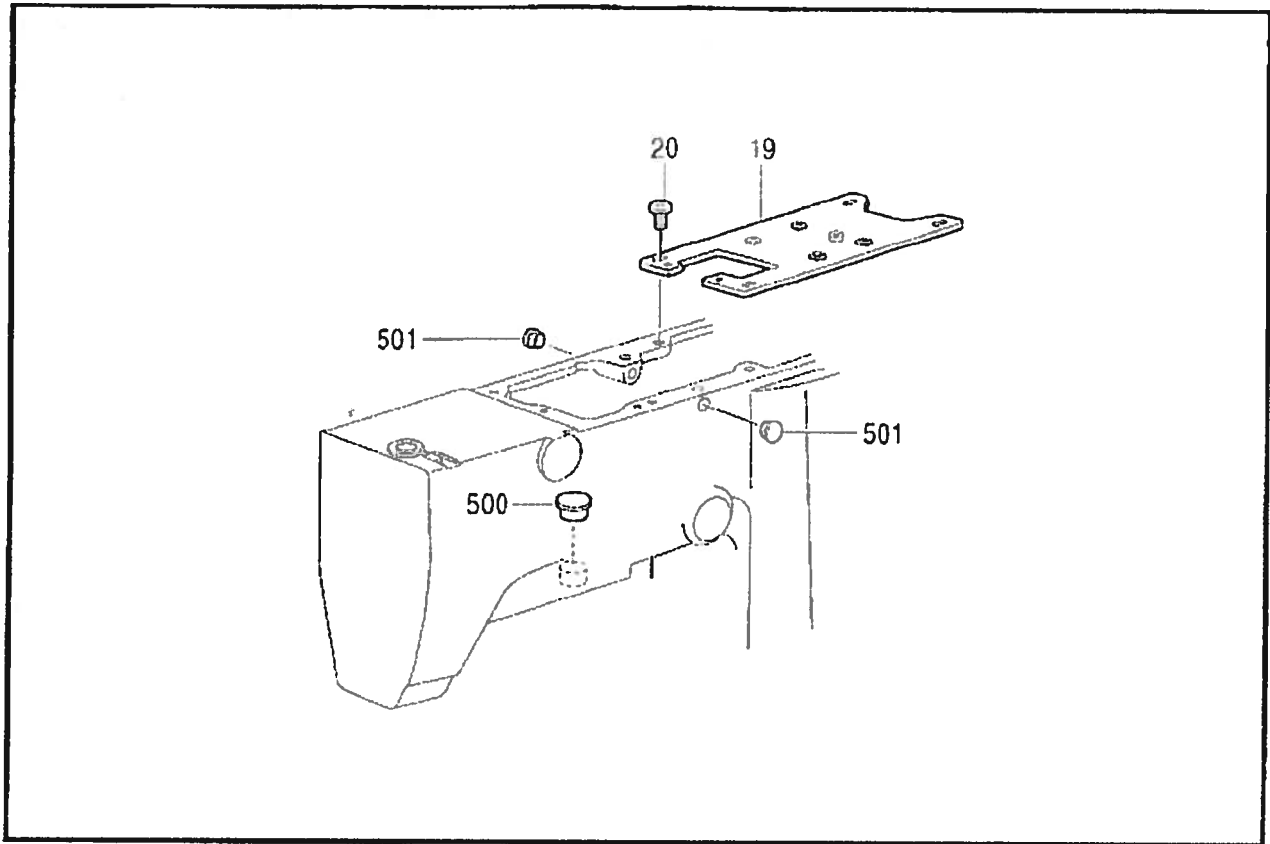

118-B84-204

E. 糸締メカニズム / Thread nipper mechanism

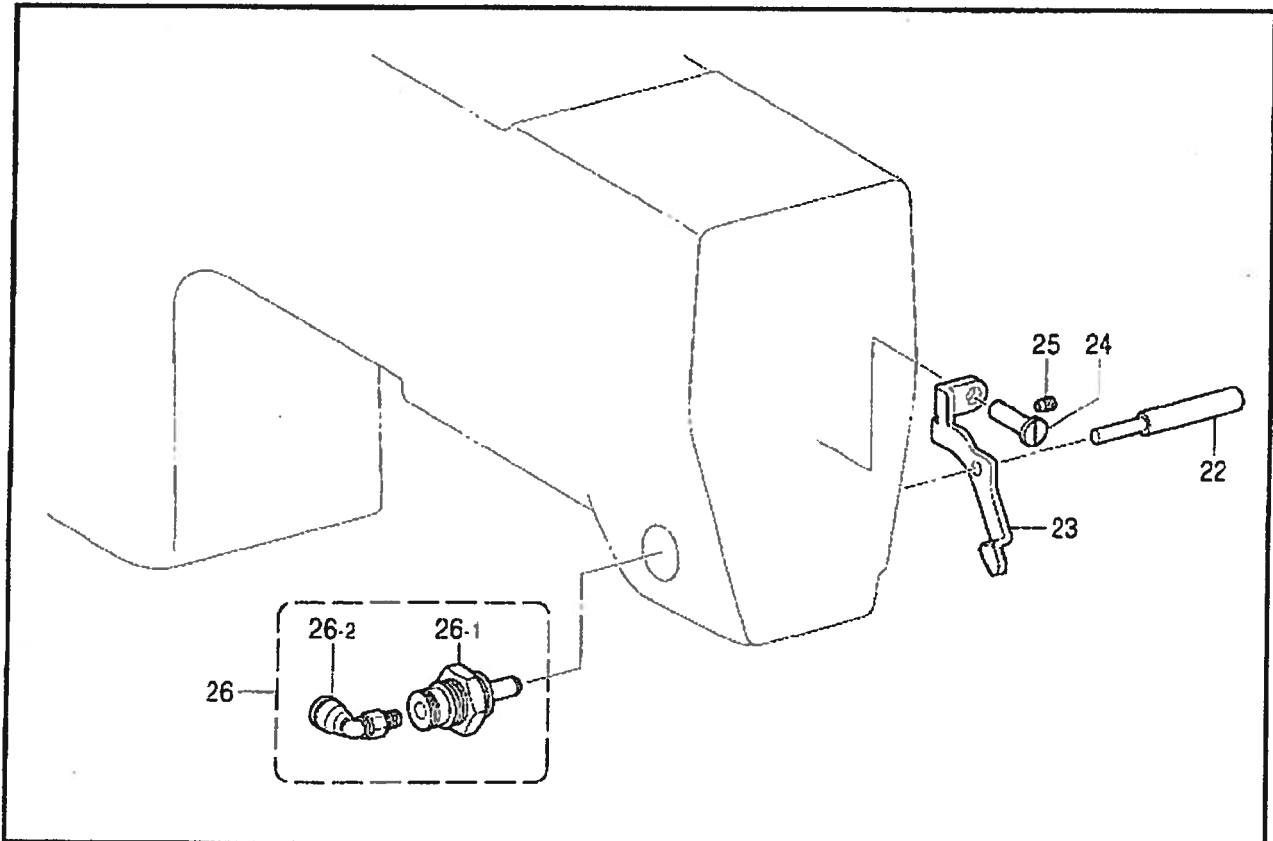

118-B84-406

D. 押エ上げ関係 / Presser fool lifter mechanism

REF.NO	CODE	QTY	ヒンメイ	NAME OF PARTS	RM
19	S49641001	1	ソレノイドリセットプレート	SOLENOID SETTING PLATE, A	
20	060681212	4	バインド 437-40X12	SCREW, BIND SM4.37-40X12	
500	S10125000	3	ゴムメン21	RUBBER CAP, 21	
501	104450101	2	ゴムメン8	RUBBER CAP, 8	

118-B84-204

E. 糸締め関係 / Thread nipper mechanism

REF.NO	CODE	QTY	ヒンメイ	NAME OF PARTS	RM
22	S55199001	1	イトユルメピン	TENSION RELEASE PIN, L	
23	S57689001	1	イトユルメピン押しレバー	TENSION RELEASE PIN PUSH LEVER	
24	S10202201	1	レバーシャフト	LEVER SHAFT	
25	014760622	1	アタメネジ 5.95	SET SCREW, SOCKET SM5.95	
26	S24523000	1	イトユルメシリンダアサミ	TENSION RELEASE CYLINDER ASSY	
26-1	S15097000	1	シリンダ 10X5	CYLINDER, 10X5	
26-2	S11426000	1	エルボユニオン4M5	ELBOW UNION, 4M5	

118-B84-406

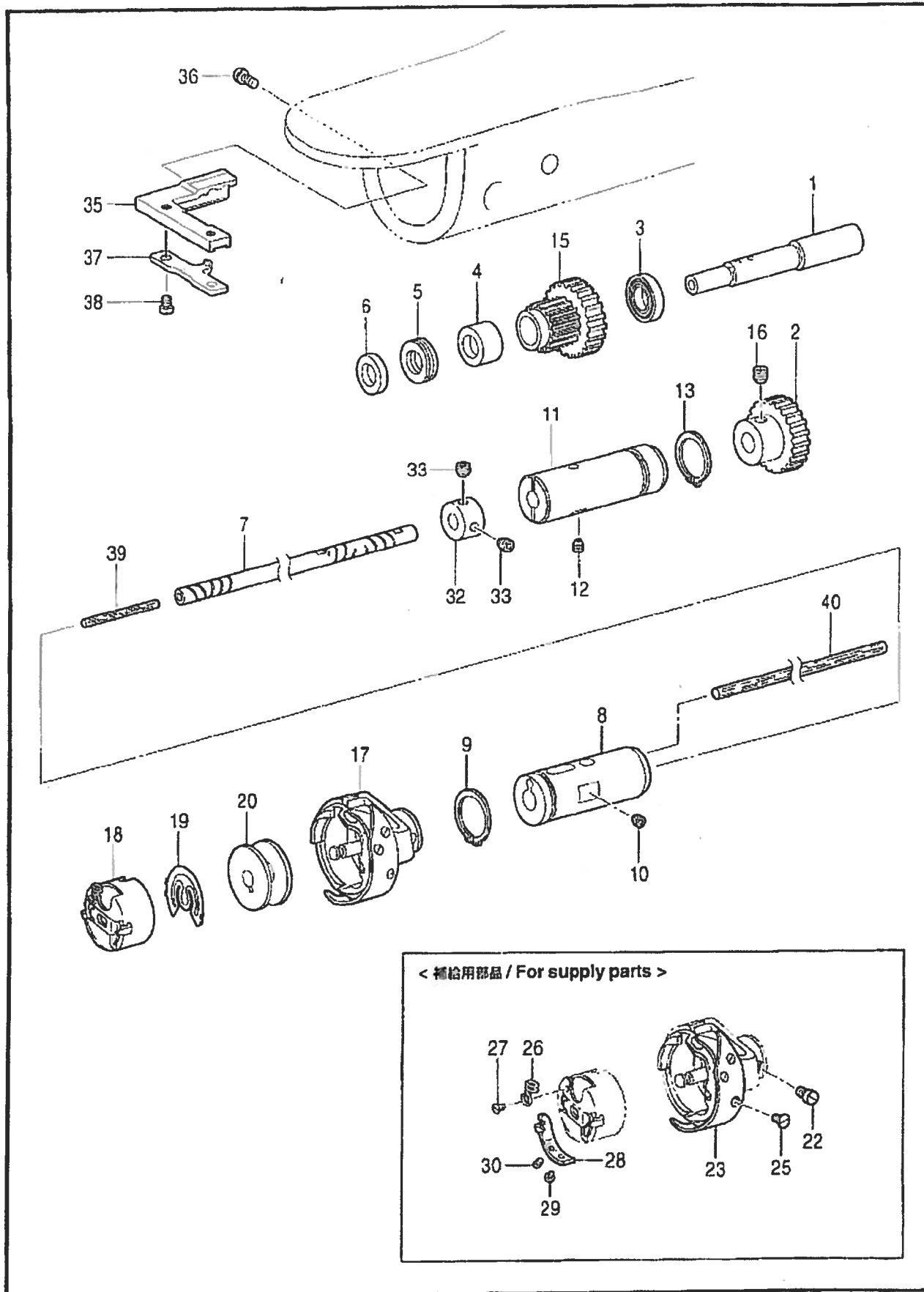

F. カマ関係 / Rotary hook mechanism

REF.NO	CODE	QTY	ヒンメイ	NAME OF PARTS	RM
1	S57646001	1	シクク	LOWER SHAFT	
2	S57647001	1	シククキ	LOWER GEAR	
3	076900800	1	シクク6900ZZ	BALL BEARING, 6900ZZ	
4	600961000	1	コシククHK1010	BEARING HK1010	
5	S57650001	1	スラストベアリング	THRUST BEARING	
6	S57651001	1	シククキヤスベ	LOWER SHAFT GEAR SPACER	
7	S57652001	1	カマシク	ROTARY HOOK SHAFT	
8	S57653001	1	カマシクメカ	ROTARY HOOK BUSH, F	
9	048200142	1	トメシククC20	RETAINING RING, EXTERNAL C20	
10	014760622	1	アトメシク 5.95	SET SCREW, SOCKET SM5.95	
11	S57654001	1	カマシクメカ	ROTARY HOOK BUSH, R	
12	014760622	1	アトメシク 5.95	SET SCREW, SOCKET SM5.95	
13	S02460001	1	トメシククC19	RETAINING RING, EXTERNAL C19	
15	S57655001	1	シクククタイミンク	LOWER SHAFT TIMING PULLEY	
16	014770622	1	アトメシク 6.35	SET SCREW, SOCKET(CP) SM6.35	
17	SA2036101	1	S06545カマシク	ROTARY HOOK ASSY, W/BOX S06545	
18	S00691401	1	ボビンケース	BOBBIN CASE ASSY, B	
19	S01767001	1	クレンボウバネ	ANTI SPIN SPRING	
20	S00871101	1	ボビン	BOBBIN, B	
			“ 補給用部品 ”	“ For supply parts ”	
22	S05822001	1	アトメシク	SET SCREW	
23	S07220001	1	アトメシク A	SPRING, A	
23	S07221001	1	アトメシク B	SPRING, B	
25	S07222001	1	アトメシク	SCREW, FLAT	
26	S15609001	1	ハリカネ	SPRING	
27	S15610001	1	アトメシク 1.85	SCREW, FLAT M1.85	
28	S00831101	1	アトメシク A	SPRING, A	
28	S00711101	1	アトメシク B	SPRING, B	
29	181937001	1	アトメシク	ADJUSTING SCREW	
30	181938001	1	アトメシク	SET SCREW	
32	104521002	1	アトメシク	SET SCREW COLLAR	
33	014770622	2	アトメシク 6.35	SET SCREW, SOCKET (CP) SM6.35	
35	SA2206001	1	アトメシク 184	HOOK STOPPER SETTING BASE	
36	153057101	1	アトメシク	SCREW, ROUND W/SOCKET SM4.37	
37	S57657001	1	アトメシク B	B-CASE HOLDER POSITION BRACKET	
38	062680612	2	アトメシク 37-40X6	SCREW, PAN SM4.37-40X6	
39	145751001	1	フェルト	FELT	
40	SA2039001	1	アトメシク	BUSH OIL FELT	

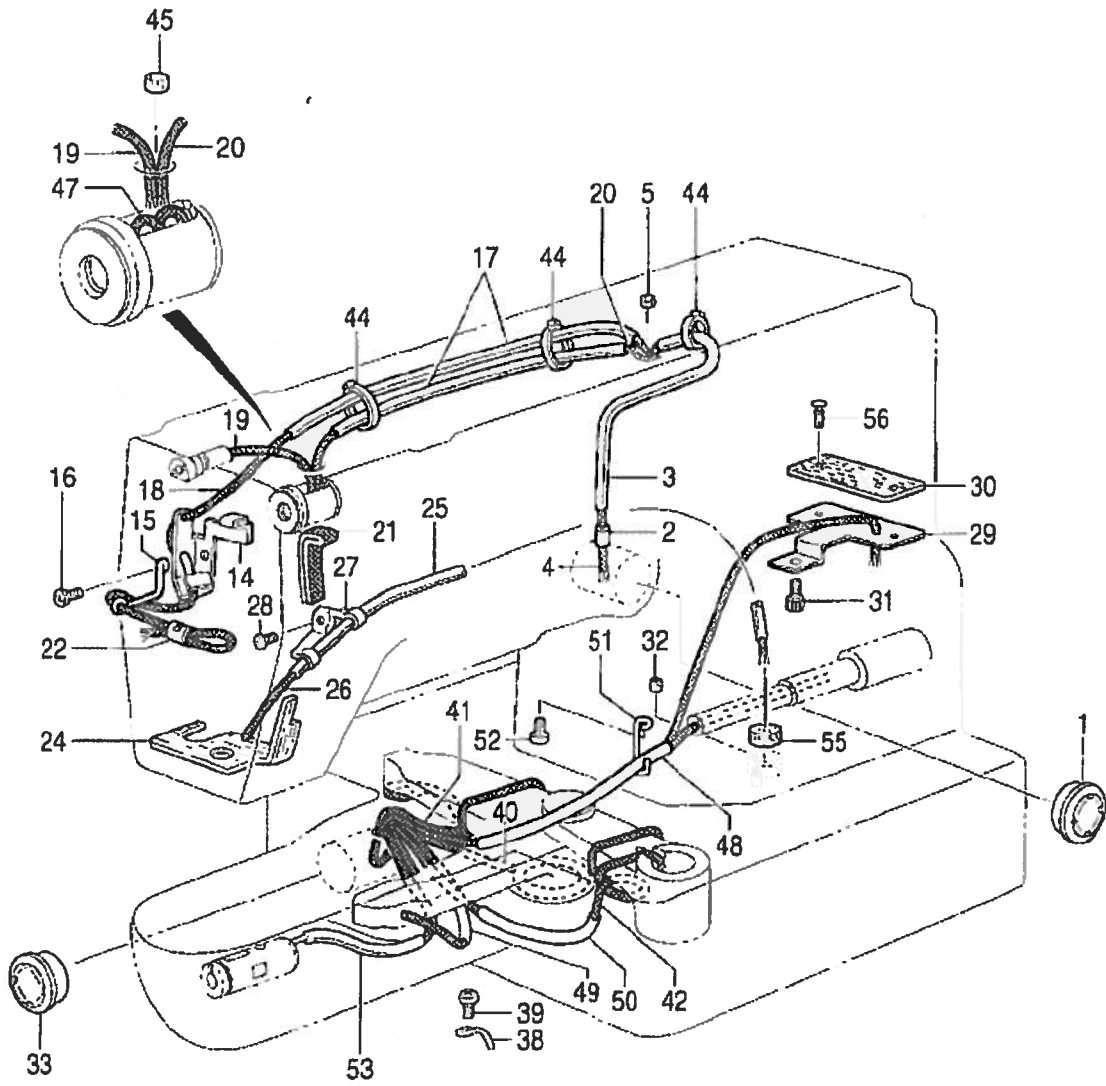

G. 給油潤滑関係 / Lubrication

REF NO	CODE	QTY	品名	NAME OF PARTS	RM
1	S49992000	1	オイルゲージ窓	OIL GAUGE WINDOW	
2	S07333001	1	オイルチューブパイプ	PIPE, S	
3	S07456000	1	ビニールチューブ	OIL TUBE, L=160	
4	148738000	1	ワック	WICK, L=335	
5	107149001	1	フェルト	FELT	
14	S49959001	1	ワック支持金	WICK SUPPORT	
15	S10162201	1	ワック支持金	WICK SUPPORT	
16	060670512	1	ナット 357-40X5	SCREW, BIND SM3.57-40X5	
17	S49620000	2	ビニールチューブ	OIL TUBE, L=340	
18	S49957000	1	ワック 4X4	WICK, 4X4 L=700	
19	S49622000	1	ワック 4X4	WICK, 4X4 L=130	
20	S49983000	1	ワック 4X4	WICK, 4X4 L=800	
21	S49984000	1	フラットワック	FLAT WICK, L=200	
22	104567101	1	ワック支持金	WICK SUPPORT	
24	S37985000	1	スライダフェルト	FELT	
25	S37986000	1	ビニールチューブ	OIL TUBE, L=440	
26	S18093100	1	ワック 4X4	WICK, 4X4 L=1100	
27	145547001	1	チューブホルダ	TUBE HOLDER	
28	062670512	1	ナット 357-40X5	SCREW, PAN SM3.57-40X5	
29	SA0216001	1	シフトワック支持金	LOWER SHAFT WICK SUPPORT	
30	SA0217001	1	シフトワック支持金	LOWER SHAFT WICK FELT	
31	018400622	1	ボルト M4X6	BOLT, SOCKET M4X6	
32	S09043000	1	フェルト	FELT	
33	152948001	1	オイルゲージ窓	OIL GAUGE WINDOW	
38	152969001	2	コードホルダ	CORD HOLDER	
39	062670512	2	ナット 357-40X5	SCREW, PAN SM3.57-40X5	
40	148738000	1	ワック	WICK, L=335	
41	148738000	1	ワック	WICK, L=335	
42	152956001	1	ワック 4X4	WICK, 4X4 L=500	
44	228475000	3	タイピングバンド 1.9X80	TYING BAND 1.9X80	
45	153924001	1	フェルト	FELT	
47	S49958000	1	ワック 4X4	WICK, 4X4 L=70	
48	S49985000	1	ビニールチューブ	OIL TUBE, L=170	
49	S49986000	1	ビニールチューブ	OIL TUBE, L=110	
50	S49987000	1	ビニールチューブ	OIL TUBE, L=150	
51	S49995001	1	コードホルダ	CORD SUPPORT	
52	062670512	1	ナット 357-40X5	SCREW, PAN SM3.57-40X5	
53	S49618000	1	ビニールチューブ	OIL TUBE, L=210	
55	113006001	1	フェルト	FELT	
56	S35001000	2	ナイロンリベット	NYLON RIVET	

1. 糸通シ関係 / Threading mechanism

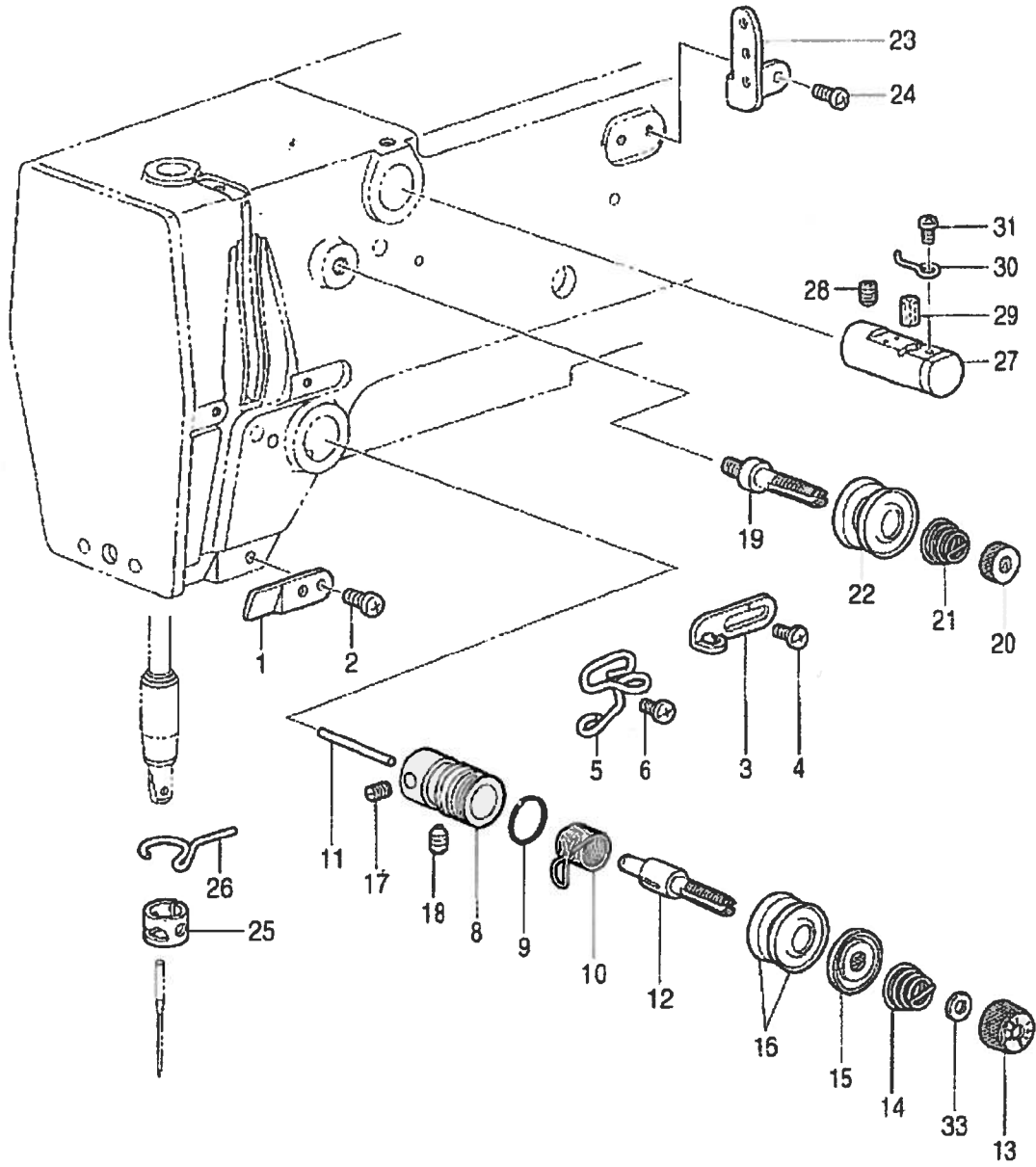

118-B84-401

H. 糸通し関係 / Threading mechanism

REF.NO	CODE	QTY	品名	NAME OF PARTS	RM
1	S53097001	1	アーム付ミチ	ARM THREAD GUIDE	
2	062710612	1	ナット M4.76-32X6	SCREW, PAN SM4.76-32X6	
3	S49627001	1	アーム付ミチ	ARM THREAD GUIDE	
4	060670612	1	ナット M3.57-40X6	SCREW, BIND SM3.57-40X6	
5	S51859101	1	アーム付アライ	ARM THREAD GUIDE	
6	060670612	1	ナット M3.57-40X6	SCREW, BIND SM3.57-40X6	
8	152872001	1	糸通し金具	TENSION BRACKET	
9	114294001	1	Oリング	O-RING	
10	144588001	1	糸取りバネ	THREAD TAKE-UP SPRING, B	
11	150551000	1	糸リリースピン	TENSION RELEASE PIN	
12	116922001	1	糸通し本釘	TENSION STUD	
13	S31032001	1	糸通しナット	TENSION NUT	
14	S06548001	1	糸通しバネC	TENSION SPRING, C	
15	159805001	1	糸通しディスクプレス	TENSION DISC PRESSER	
16	145446001	2	糸通しディスク	TENSION DISC	
17	100402004	1	セットネジ M3.57	SET SCREW, SM3.57	
18	S10469001	1	アタネネジ M5.95	SET SCREW, SOCKET SM5.95	
19	115186001	1	メイン糸通し本釘	MAIN TENSION STUD	
20	100136001	1	糸通しナット	TENSION NUT	
21	107606001	1	糸通しバネH	TENSION SPRING, H	
22	145446001	2	糸通しディスク	TENSION DISC	
23	152889001	1	ミツメ付ミチ	THREAD RETAINER	
24	062670612	2	ナット M3.57-40X6	SCREW, PAN SM3.57-40X6	
25	S02439001	1	ナット付アライ	N-BAR THREAD GUIDE, B	
26	152891101	1	ナット付メタアライ	N-BAR BUSH THREAD GUIDE, D	
27	152881001	1	イキレ付ミチ	NEEDLE COOLER ASSY	
28	014760632	1	アタネネジ M5.95-28X6	SET SCREW, SOCKET (CP)SM5.95X6	
29	152883000	1	フェルト 8X15.5	FELT, 8X15.5	
30	152884001	1	イキレ付ミチ	NEEDLE COOLER THREAD GUIDE	
31	062670412	1	ナット M3.57-40X4	SCREW, PAN SM3.57-40X4	
33	S12441001	1	糸通しバネのワッシャー	WASHER	

J. 糸巻關係 / Bobbin winder mechanism

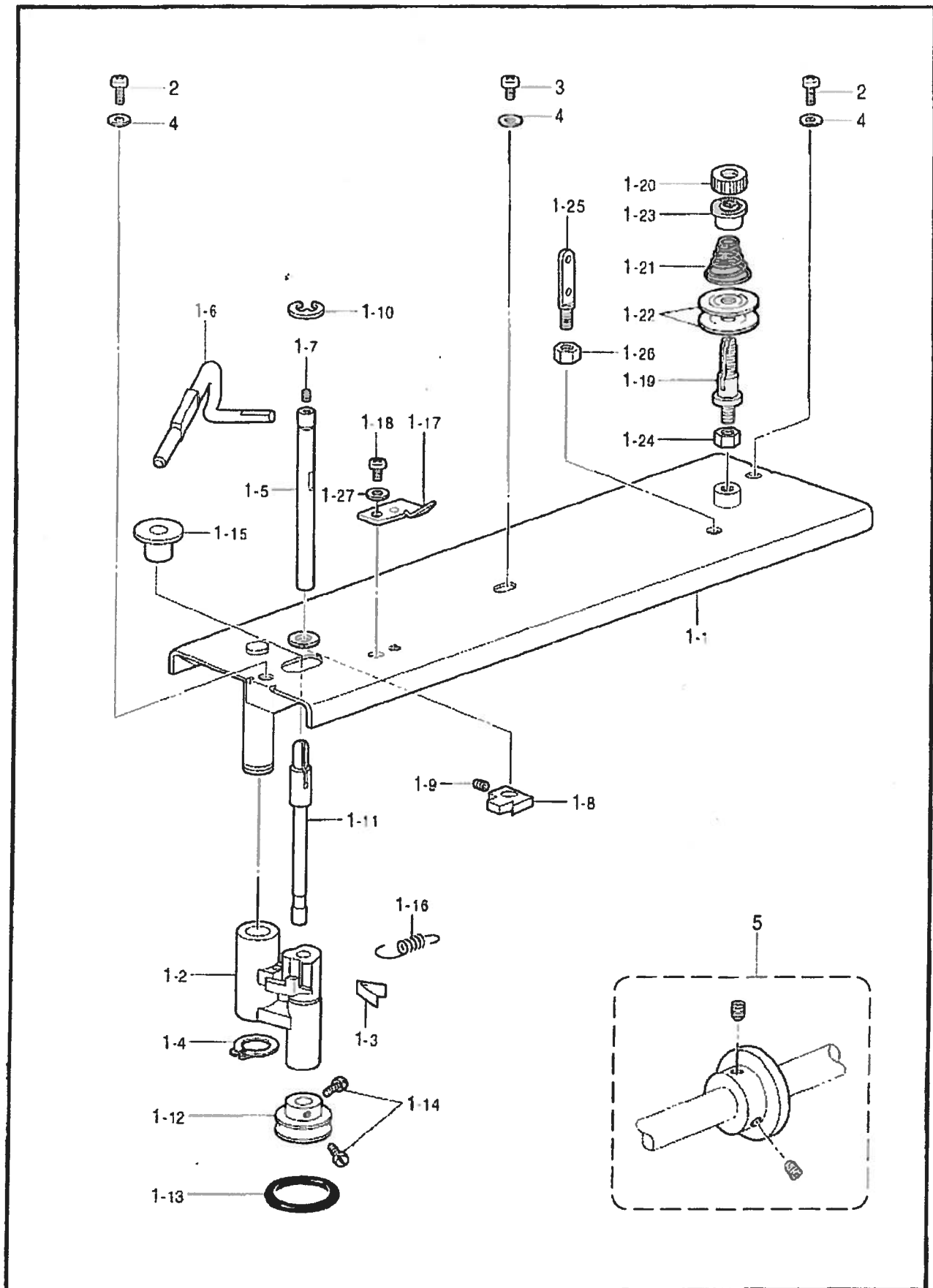

J. 糸巻関係 / Bobbin winder mechanism

REF NO	CODE	QTY	品名	NAME OF PARTS	RM
1-1	SA1587001	1	ウツクミコ	UPPER COVER SUB ASSY	
1-2	S37992100	1	トキテ	BOBBIN WINDER ARM	
1-3	S37993000	1	イハネ	PLATE SPRING	
1-4	048100142	1	トメシク30C10	RETAINING RING, EXTERNAL C10	
1-5	S37994001	1	トキメシク	BOBBIN WINDER CLAW STUD	
1-6	S57635001	1	ホビシオサ184	BOBBIN PRESSER, 484	
1-7	100402004	1	トメシク 3.57	SET SCREW, SM3.57	
1-8	S37996001	1	トキメ	BOBBIN WINDER CLAW	
1-9	014680622	1	ソケットメシク 4.37	SET SCREW, SOCKET (CP) SM4.37	
1-10	048050342	1	トメシク E5	RETAINING RING, E5	
1-11	S57661001	1	トメシク 484	BOBBIN WINDER SHAFT	
1-12	154528001	1	トメシク	BOBBIN WINDER WHEEL	
1-13	120448001	1	ゴム	RUBBER BAND	
1-14	120990001	2	ソケットメシク 4.37	SET SCREW, (CP) SM4.37-40X8	
1-15	S10174000	1	ホリコ	DUST GUARD PLATE	
1-16	S37998001	1	トキテ	SPRING	
1-17	157968001	1	メス	KNIFE	
1-18	062680512	1	ネジ 437-40X5	SCREW, PAN SM4.37-40X5	
1-19	159574101	1	トキテ	TENSION STUD	
1-20	100136001	1	トキテ	TENSION NUT	
1-21	148851001	1	トキテ	TENSION SPRING	
1-22	145446001	2	トキテ	TENSION DISC	
1-23	144105000	1	トキテ	TENSION SPRING FLANGE WASHER	
1-24	021680202	1	ナット 2. 37	NUT, 2 SM4.37	
1-25	141590001	1	トキテ	THREADING BAR, U	
1-26	100022004	2	ナット 5. 95	NUT, SM5.95	
1-27	025680232	1	ワシカ 4. 37	WASHER, PLAIN M 4.37	
2	062681212	2	ネジ 437-40X12	SCREW, PAN SM4.37-40X12	
3	062680612	1	ネジ 4. 37-40X6	SCREW, PAN SM4.37-40X6	
4	025680232	3	ワシカ 4. 37	WASHER, PLAIN M 4.37	
5	S47335101	1	トキテ	BOBBIN WINDER PULLEY ASSY	

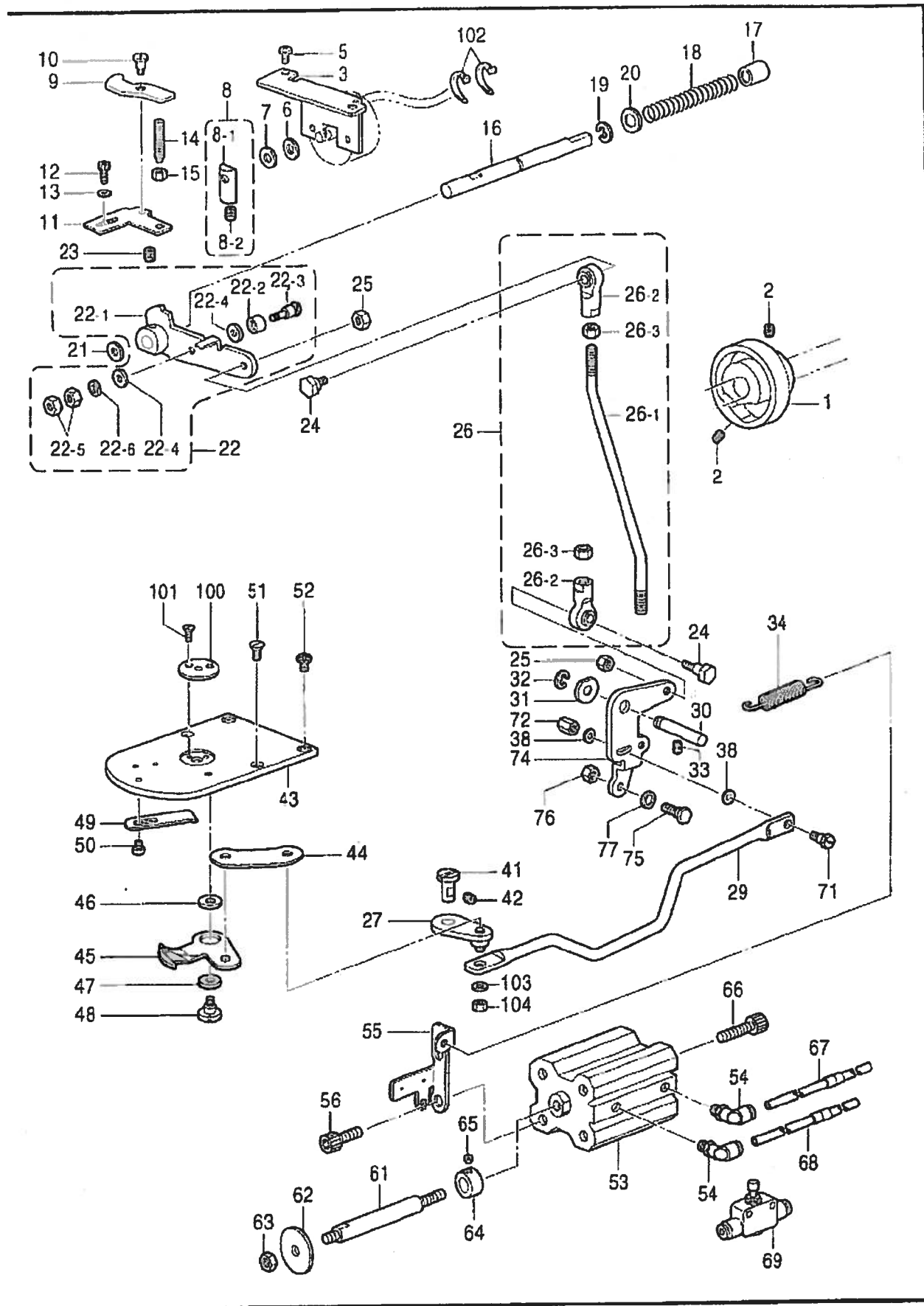

K. 糸切り関係 / Thread trimmer mechanism

REF.NO	CODE	Q'TY	品名	NAME OF PARTS	RM
1	S57662001	1	糸切りカム484	THREAD TRIMMER CAM, 484	
2	014770622	2	アタメネジ 6.35X6.35	SET SCREW, SOCKET (CP) SM6.35	
3	S38002201	1	ソレノイドトリガ板	SOLENOID SETTING PLATE	
5	060681212	2	バインド 437-40X12	SCREW, BIND SM4.37-40X12	
6	154599000	1	ソレノイドクッション	SOLENOID CUSHION	
7	S02652001	1	ワッシャー	WASHER	
8	S23836001	1	ソレノイドレバ - クミ	SOLENOID LEVER ASSY	
8-1	S02654001	1	ソレノイドレバ -	SOLENOID LEVER	
8-2	014680632	1	アタメネジ 437-40X6	SET SCREW, SOCKET (CP) SM4.37	
9	S38003101	1	外レバ - オシレバ -	DRIVING LEVER PUSH LEVER	
10	145478101	1	ダンネジ 4.76	SHOULDER SCREW, SOCKET SM4.76	
11	S38004002	1	外レバ - ストップ	DRIVING LEVER STOPPER <Marked in 2>	<記号2>
11	S38004003	1	外レバ - ストップ	DRIVING LEVER STOPPER <Marked in 3>	<記号3>
11	S38004004	1	外レバ - ストップ	DRIVING LEVER STOPPER <Marked in 4>	<記号4>
12	S59893001	2	アタメネジ 4.37X10	BOLT, SOCKET SM4.37X10	
13	148847001	2	ワッシャー	WASHER, PLAIN 4.76	
14	159905001	1	調整ネジ	ADJUSTING SCREW	
15	105812003	1	ナット 7.94	NUT, SM7.94	
16	S38005001	1	外レバ - アンナインク	DRIVING LEVER SHAFT	
17	231071001	1	ブッシュ 8X15	BUSH, 8X15	
18	S32235001	1	スプリング	SPRING, COMPRESSION	
19	048070342	1	保持リング E7	RETAINING RING, E7	
20	153596001	1	ワッシャー	WASHER	
21	154596000	1	糸切りカムレバ - クッション	CUSHION	
22	S49646101	1	糸切りレバ - クミ	THREAD DRIVING LEVER ASSY	
22-1	S59874001	1	糸切りレバ -	THREAD DRIVING LEVER	
22-2	S59872001	1	糸切りローラー	THREAD TRIMMER ROLLER	
22-3	S59871001	1	ダンネジ 4.37	SHOULDER SCREW, SM4.37	
22-4	S59873001	2	ワッシャー	WASHER, PLAIN	
22-5	SA0049001	2	ナット 4.37	NUT, SM4.37	
22-6	028680242	1	バネ 2-4.37	WASHER, SPRING 2-4.37	
23	014770622	1	アタメネジ 6.35X6.35	SET SCREW, SOCKET (CP) SM6.35	
24	S02354001	2	ダンネジ B	SHOULDER SCREW, B	
25	100022005	2	ナット 5.95	NUT, SM5.95	
26	S49648001	1	糸切りロッド	THREAD TRIMMER ROD ASSY	
26-1	S49649001	1	糸切りロッド	THREAD TRIMMER ROD	
26-2	141492001	2	ジョイント	JOINT ASSY	
26-3	100022005	2	ナット 5.95	NUT, SM5.95	
27	S57665001	1	接続レバ	CONNECTING ROD LEVER	
29	S57664001	1	糸切りロッド L	THREAD TRIMMER ROD, L	
30	S10195101	1	糸切りレバシャフト	THREAD TRIMMER LEVER SHAFT	
31	110367001	1	ワッシャー	WASHER, PLAIN SPECIAL 8	
32	048060342	1	保持リング E6	RETAINING RING, E6	
33	014760822	1	アタメネジ 5.95	SET SCREW, SOCKET SM5.95	
34	S57686001	1	延長スプリング	EXTENSION SPRING	
38	S49994001	2	ワッシャー 4.76	WASHER, PLAIN 4.76	
41	S10202201	1	接続レバシャフト	LEVER SHAFT	
42	014680622	1	アタメネジ 4.37X6.35	SET SCREW, SOCKET (CP) SM4.37	
43	S57663001	1	針板 484	NEEDLE PLATE, 484	
44	S57667001	1	糸切り接続ロッド 484	T-TRIMMER CONNECTING ROD, 484	
45	S57668001	1	移動ナイフ 484	MOVABLE KNIFE 484 ASSY	
46	S10208001	1	移動ナイフスペーサー	MOVABLE KNIFE SPACER <t=0.4>	<t=0.4>
46	S10208002	1	移動ナイフスペーサー	MOVABLE KNIFE SPACER <t=0.5>	<t=0.5>
46	S10208003	1	移動ナイフスペーサー	MOVABLE KNIFE SPACER <t=0.6>	<t=0.6>
46	S10208004	1	移動ナイフスペーサー	MOVABLE KNIFE SPACER <t=0.7>	<t=0.7>
47	S00705001	1	移動ナイフカラー	MOVABLE KNIFE COLLAR	
48	S10209101	1	ネジ 4.37	SCREW, SM4.37	
49	S57670001	1	固定ナイフ 484	FIXED KNIFE, 484	
50	111140002	2	ネジ 2.38	SCREW, SM2.38	
51	100032004	2	ネジ 4.37	SCREW, FLAT SM4.37-40X8	
52	S11244001	2	ネジ 4.37	SCREW, SM4.37	

K. 糸切り関係 / Inthead trimmer mechanism

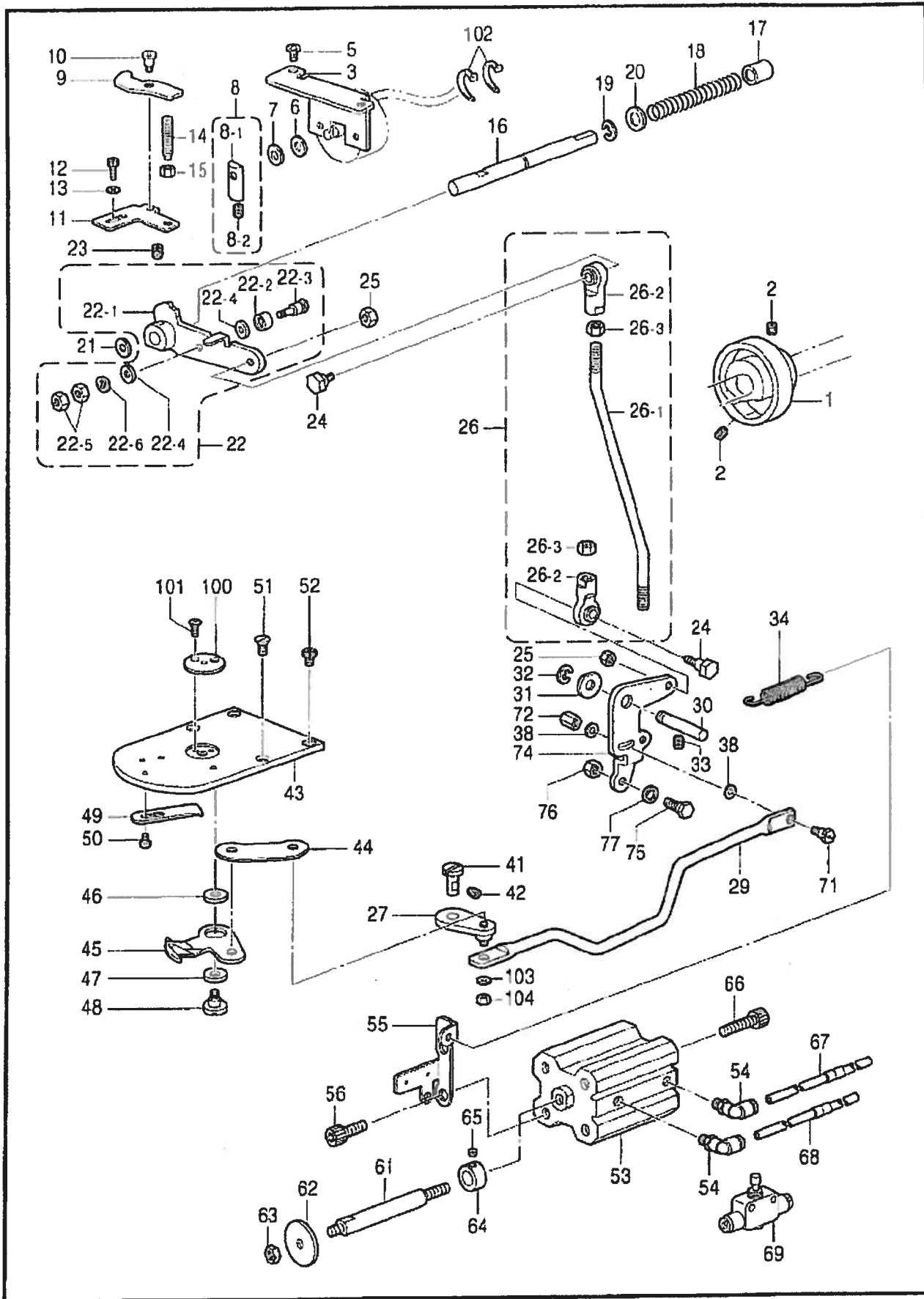

118-B84-403

K. 糸切り関係 / Thread trimmer mechanism

REF.NO	CODE	QTY	品名	NAME OF PARTS	RM
53	S57673001	1	イトキリシリンダ-	THREAD TRIMMER CYLINDER	
54	S53488000	2	ツキテ	JOINT	
55	S57705001	1	センサ-トリツカケイ	SENSOR SETTING BRACKET	
56	018061436	2	アソルト6X14	BOLT, SOCKET M6X14	
61	S57681001	1	イトキリモトシロツ	EXTENSION ROD	
62	141400009	1	ワカネ	WASHER	
63	021060102	2	ナツト1.6	NUT, 1 M6	
64	S10892001	1	セツトカラ-	SET SCREW COLLAR	
65	123006001	1	トメネシ 6.35ツホミ	SET SCREW, (CP) SM6.35	
66	018061436	2	アソルト6X14	BOLT, SOCKET M6X14	
67	S43687001	1	ナイロチューブR	AIR TUBE, R	
68	S43687002	1	ナイロチューブR	AIR TUBE, R	
69	S09197000	1	スピードコントローラ	SPEED CONTROLLER	
71	110233001	1	タシネシ 4.76	SHOULDER SCREW, SM4.76	
72	SA0219001	1	ナツト4.76	NUT, SM4.76	
74	S57674001	1	イトキリレバ-	THREAD TRIMMER LEVER	
75	SA0218001	1	タシネシ 5.95	SHOULDER SCREW, SM5.95	
76	100022005	1	ナツト5.95	NUT, SM5.95	
77	S12696001	1	コロ	ROLLER	
100	*	1	ハリアナイタ	NEEDLE HOLE PLATE	
101	100360003	2	ツラネシ 2.38	SCREW, FLAT SM2.38	
102	228475000	2	ツツクバンド 1.9X80	TYING BAND 1.9X80	
103	100645003	1	ワカネ	WASHER	
104	102571003	1	ナツト4.37	NUT, SM4.37	

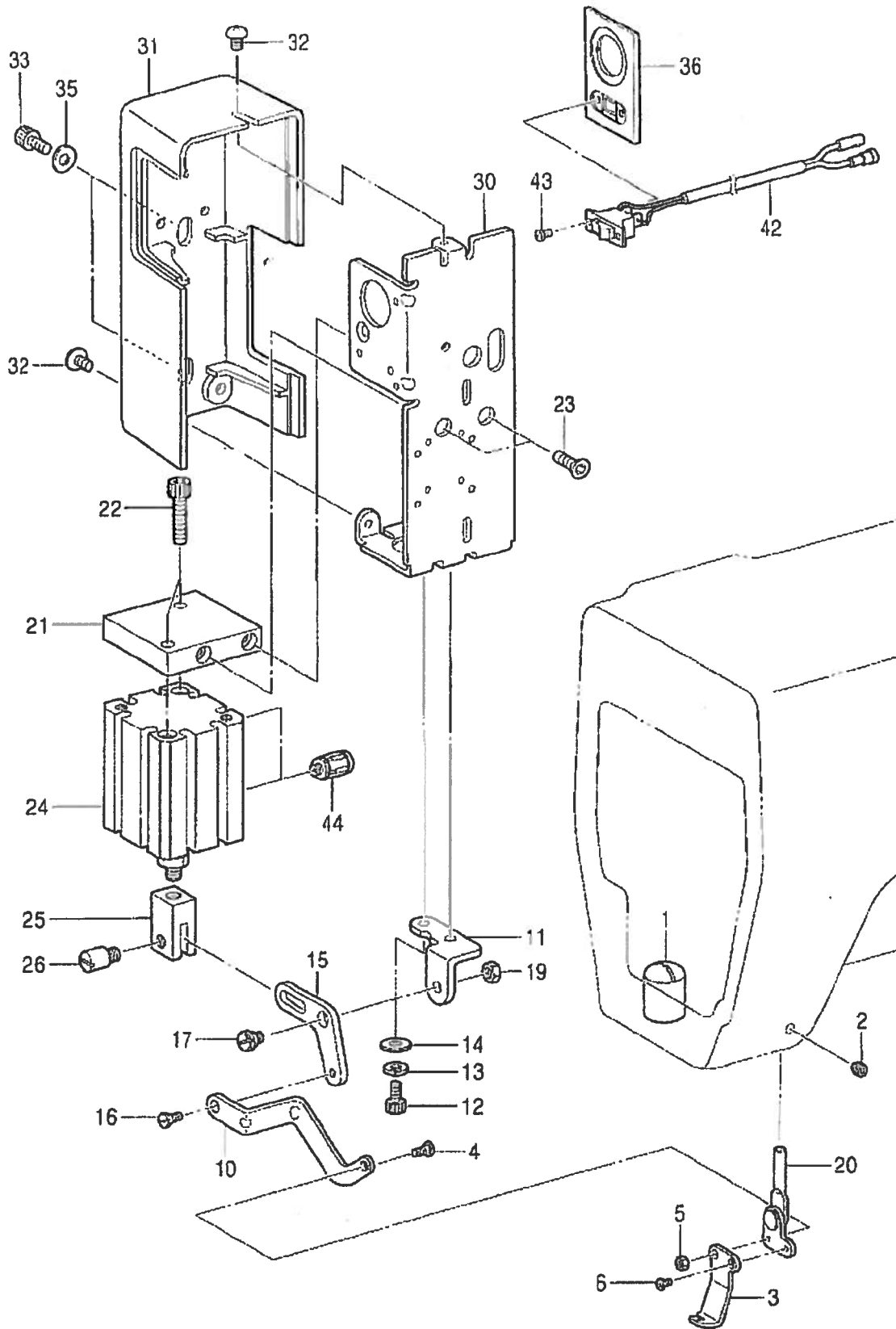

L. 系 払イ関係 / Tension release mechanism

REF.NO	CODE	Q'TY	ヒンメイ	NAME OF PARTS	RM
1	152827001	1	オイルキャップ	OIL CAP	
2	014710522	1	アタメネジ 4.76φ×ミ	SET SCREW, SOCKET (CP) SM4.76	
3	S57872001	1	ワイパ-84	WIPER, 84	
4	153112001	1	クワンネジ 3.57	SHOULDER SCREW, SM3.57	
5	021670202	1	ナット2φ3.57	NUT, 2 SM3.57	
6	060670412	1	バ-インド 357-40X4	SCREW, BIND SM3.57-40X4	
10	S57867001	1	イトワイレンカンST	T-WIPER CONNECTING ROD, ST	
11	S57868001	1	レンカンレバ-トリツクイ	CON. ROD LEVER SETTING PLATE	
12	018400836	2	アホ-ボルト4X8	BOLT, SOCKET M4X8	
13	028040246	2	ハ-ネジ 2-4	WASHER, SPRING 2-4	
14	025040236	2	ヒラサ-ネジ1φ4	WASHER, PLAIN M 4	
15	S57869001	1	イトワイレンカンレバ-	T-WIPER CONNECTING ROD LEVER	
16	153112001	2	クワンネジ 3.57	SHOULDER SCREW, SM3.57	
17	155167002	1	クワンネジ 5.56	SHOULDER SCREW, SM5.56	
19	021750302	1	ナット3φ5.56	NUT, 3 SM5.56	
20	S56864001	1	ワイパ-ア-ムテ-クミ	WIPER ARM ASSY	
21	S57876001	1	シリンダ-トリツクイ	CYLINDER SETTING PLATE	
22	018062022	2	アホ-ボルト6X20	BOLT, SOCKET M6X20	
23	149482001	2	アツキワホ-ボルトM6X15	BOLT, FLAT W/SOCKET M6X15	
24	S57873001	1	イトワイシリンダ-	THREAD WIPER CYLINDER	
25	S57872001	1	シリンダ-ツキテ	CYLINDER JOINT	
26	S21881001	1	シメネジ 4.76	SCREW, SM4.76	
30	S57874001	1	AWシリンダ-トリツクイ	CYLINDER SETTING PLATE, AW	
31	SA0771001	1	AWシリンダ-カバー	CYLINDER COVER, AW	
32	S55151000	3	トラスコ3X6	SCREW, TRUSS M4X6	
33	S59893001	2	アホ-ボルト4.37X10	BOLT, SOCKET SM4.37X10	
35	100645003	2	ワ-カ-ネ	WASHER	
36	S55133000	1	イトワイSOLカバー-フタ	LID, S COVER	
42	S43843009	1	イトワイスイッチクミ	THREAD WIPER SWITCH ASSY	
43	062300612	2	ナ-コ3X6	SCREW, PAN M3X6	
44	S18415101	2	ハ-フユニオン	HALF UNION	

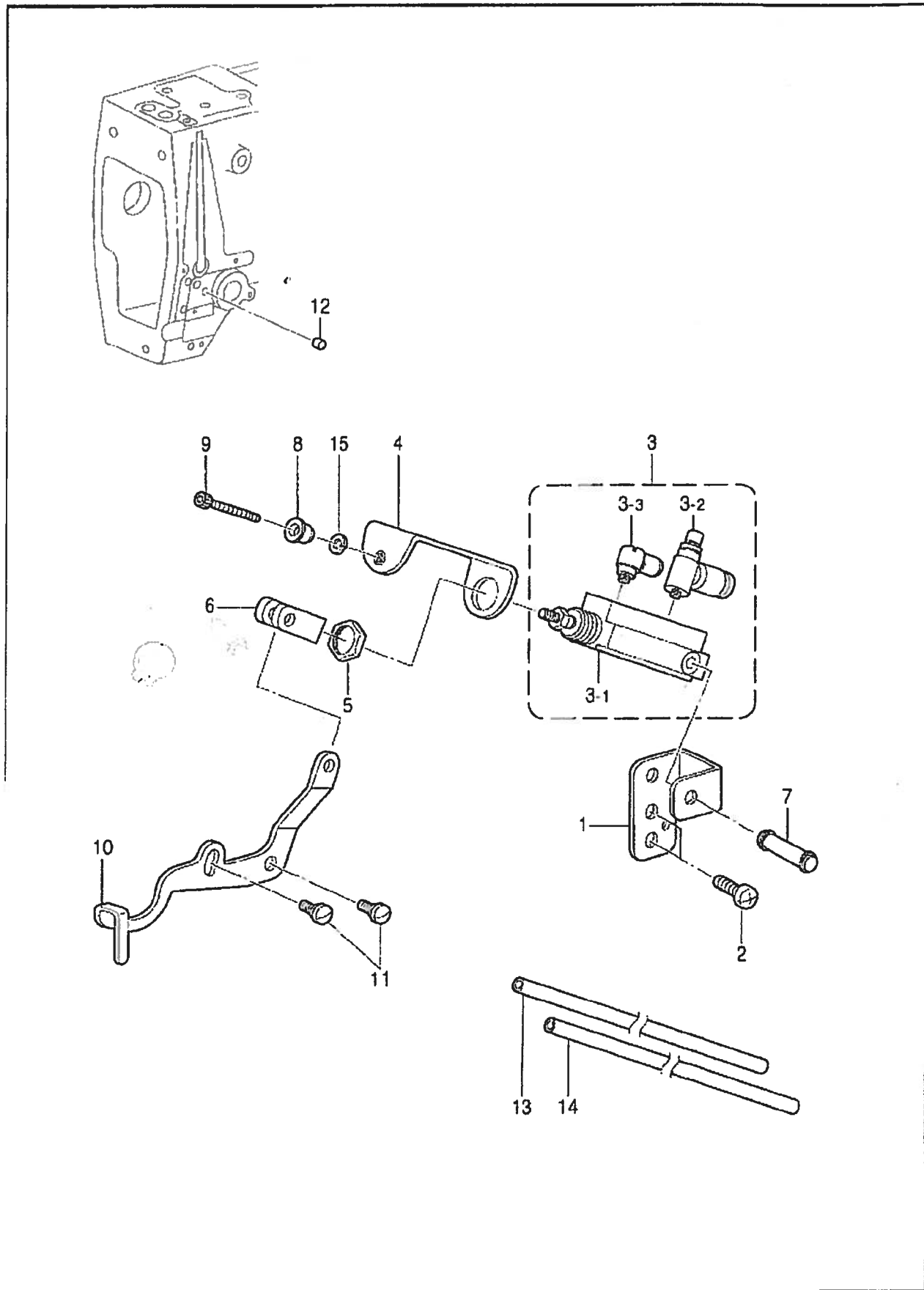

M. 糸取り関係 / Thread take-up mechanism

REF.NO	CODE	Q'TY	ヒンメイ	NAME OF PARTS	RM
1	S56531001	1	シリンダトリツガイ	SETTING PLATE	
2	062710812	2	ナベ 3476-32X8	SCREW, PAN SM4.76-32X8	
3	S50052000	1	ピンシリンダクミ	PIN CYINDER ASSY	
3-1	S50048000	1	ピンシリンダ	PIN CYLINDER	
3-2	S23660000	1	スピードコントローラ	SPEED CONTROLLER	
3-3	S12150000	1	ホースエルボ M-5HL-4	TUBE ELBOW, M-5HL-4	
4	S56532001	1	ストップブラケット	STOPPER BRACKET	
5	S50051000	1	ナットM12	NUT, M12	
6	S50050000	1	フタマナツクル	KNUCKLE	
7	S50049000	1	ピン	PIN	
8	S32259001	1	プレテンションナット	PRE-TENSION NUT	
9	018401636	1	ボルト M4X16	BOLT, SOCKET M4X16	
10	S56533101	1	レバー	LEVER	
11	107321003	2	タンスクリュー 4.76	SHOULDER SCREW, SM4.76	
12	S20878000	1	ゴムキャップ 5.3	RUBBER CAP, 5.3	
13	S18387006	1	エアチューブ	AIR TUBE, 4 L	
14	S18387006	1	エアチューブ	AIR TUBE, 4 L	
15	028040246	1	ワッシャー カ 32-4	WASHER, SPRING 2-4	

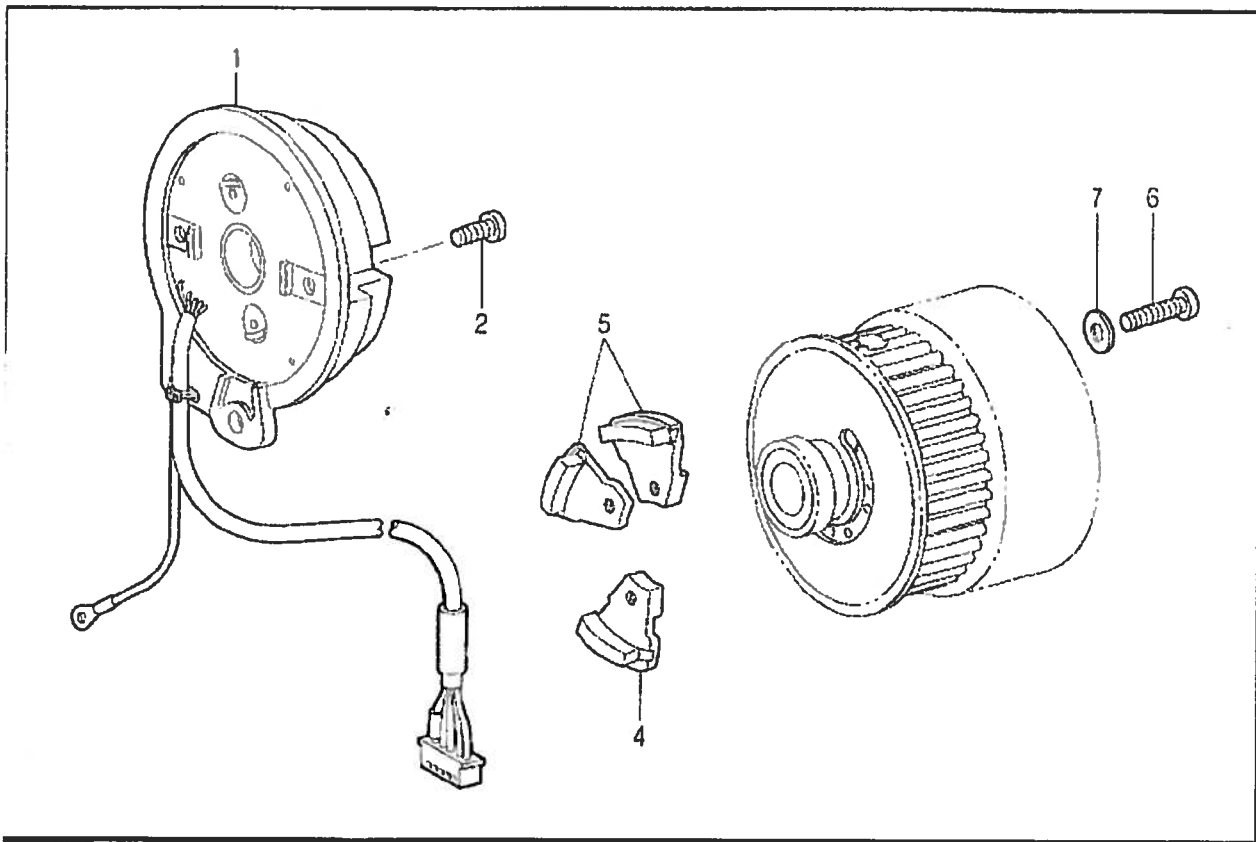

P. プリント基板関係 / Printed circuit board mechanism

118-B84-501

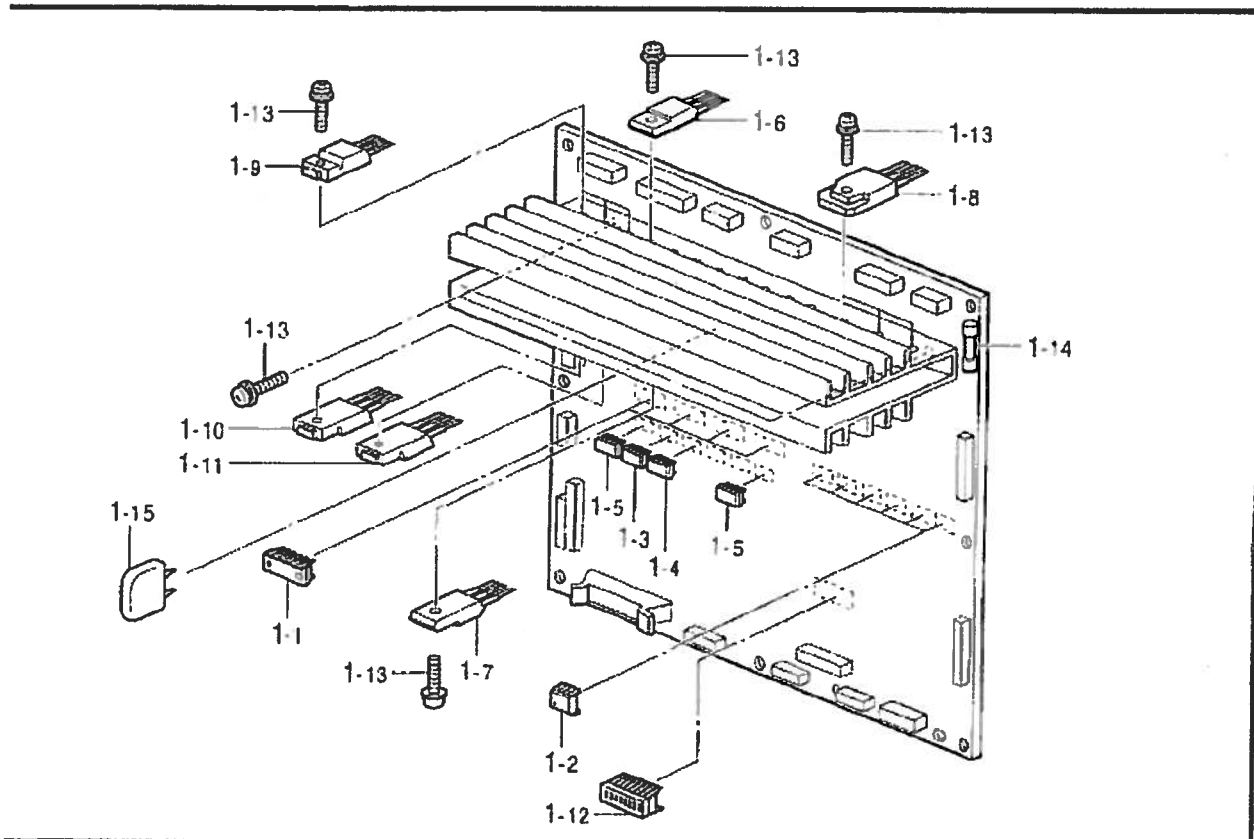

118-B84-518

N. 針位置検出器関係 / Synchronizer

REF.NO	CODE	QTY	ヒンメイ	NAME OF PARTS	RM
1	S48666001	1	シンクロイザクミ	SYNCHRONIZER ASSY	
2	062400806	2	ナハコ4X8	SCREW, PAN M4X8	
4	S38080001	1	ハリシジシバクミ	NEEDLE LOWER MAGNET ASSY, D	
5	S38082001	2	ハリシジシバクミ	NEEDLE UPPER MAGNET ASSY, U	
6	062681412	3	ナハコ437-40X14	SCREW, PAN SM4.37-40X14	
7	025680132	3	ヒラサガネシヨウ4.37	WASHER, PLAIN S 4.37	

118-B84-501

P. プリント基板関係 / Printed circuit board mechanism

REF.NO	CODE	QTY	ヒンメイ	NAME OF PARTS	RM
1	S49479001	1	メイン基板クミ	MAIN PCB ASSY	
1-1	S29019000	4	ICM54640P	IC:M54640P	
1-2	S43178000	6	PHカ775PC9231	PHOTO COUPLER:PC9231	
1-3	093650008	1	CMOSIC74HC08F	IC:74HC08F	
1-4	093650032	1	CMOSIC74HC32F	IC:74HC32F	
1-5	091170009	2	BIPIC74LS09F	IC:74LS09F-T	
1-6	S49484000	8	MOSFETFS10KMJ-2	TRANSISTOR, FET:FS10KMJ-2	
1-7	S49485000	8	MOSFETFX6KMJ-2	TRANSISTOR, FET:FX6KMJ-2	
1-8	S49471000	6	MOSFETFK18SM-12	TRANSISTOR, FET:FK18SM-12	
1-9	S38155000	3	MOSFET2SK1306	TRANSISTOR, FET:2SK1306	
1-10	S50645000	1	MOSFET2SK1307	TRANSISTOR, FET:2SK1307	
1-11	S49486000	1	MOSFET2SJ222	TRANSISTOR, FET:2SJ222	
1-12	U32744000	1	DIPSWDSS708	DIP SWITCH:DSS708	
1-13	0A4301005	31	ナハコ3X10DA	SCREW, PAN (S/P WASHER) M3X10	
1-14	S48578000	1	GFUSE5AFBリットツト	GLASS FUSE, 5A W/LEED WIRE	
1-15	Y51030150	1	※UC50B103	CAPACITOR.POLYSTER 50B103	

118-B84-518

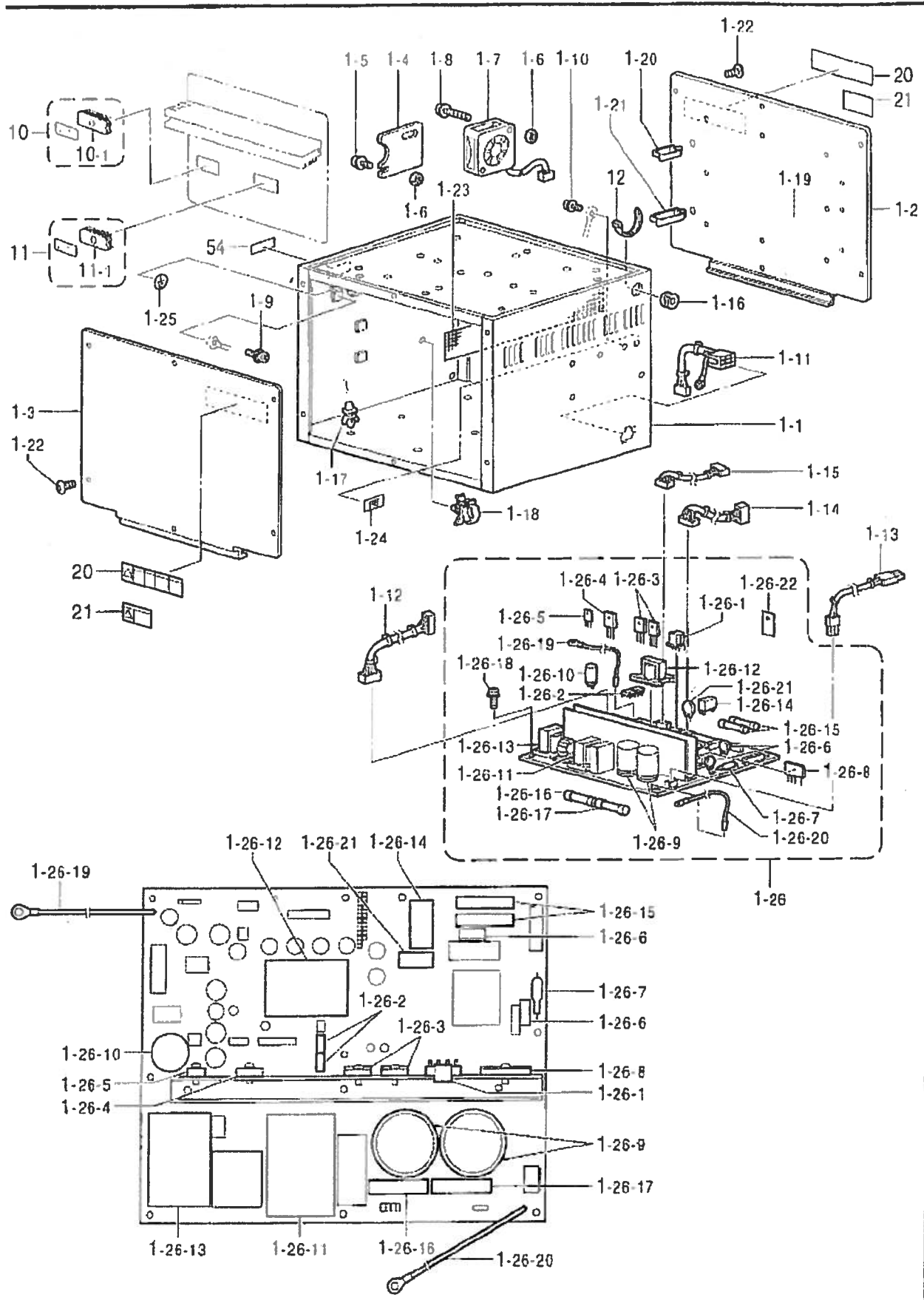

Q1. コントロールボックス関係 / Control box mechanism

REF.NO	CODE	QTY	ヒンメイ	NAME OF PARTS	RM
1	S49467001	1	ボックス	BOX ASSY	
1-1	S49468001	1	電源ボックス	POWER SUPPLY BOX	
1-2	S49469001	1	メイン基板	MAIN PCB SETTING PLATE	
1-3	S49470001	1	ボックス	BOX COVER	
1-4	S38093000	1	ホルダ	HOLDER PLATE	
1-5	0A5401206	2	ネジ	SCREW, PAN (S/P WASHER) M4X12	
1-6	021400206	2	ナット	NUT, 2 M4	
1-7	S47692000	1	ファンモーター	FAN MOTOR ASSY, DC	
1-8	0A5403006	2	ネジ	SCREW, PAN (S/P WASHER) M4X30	
1-9	0A5400806	1	ネジ	SCREW, PAN (S/P WASHER) M4X8	
1-10	0A5401206	2	ネジ	SCREW, PAN (S/P WASHER) M4X12	
1-11	S42260000	1	フットスイッチ	FOOT SWITCH HARNESS ASSY, 434	
1-12	S38107100	1	制御電源	CONTROL POWER SUPPLY HARNESS	
1-13	S38108000	1	モーター	MOTOR POWER SUPPLY HARNESS	
1-14	S38109100	1	高圧電源	H-P POWER SUPPLY HARNESS	
1-15	S38110000	1	電源	POWER HARNESS	
1-16	S11949000	1	ゴム	RUBBER BUSH	
1-17	S00554000	17	支柱	SUPPORT, 6NS	
1-18	S31760000	2	ケーブル	CORD CLAMP, 26-L	
1-19	S43275000	6	ケーブル	CORD CLAMP, WS2NS	
1-20	S43276000	4	ケーブル	CORD CLAMP, WS3NS	
1-21	S43277000	1	ケーブル	CORD CLAMP, WS4NS	
1-22	008400604	12	ボルト	SCREW, TRUSS M4X6	
1-23	S38116000	1	保護ネット	FRAGMENT PROTECTOR NET	
1-24	S37059001	1	ラベル	LABEL, PE	
1-25	S37060001	1	ラベル	LABEL, GROUNDING	
1-26	S49939101	1	電源基板	POWER SUPPLY PCB ASSY	
1-26-1	S43177000	1	IC	IC :MA3830	
1-26-2	S43184000	2	フォトカプラー	PHOTO COUPLER :PC923	
1-26-3	S49586000	2	トランジスタ	TRANSISTOR, FET :2SK1941	
1-26-4	S55473000	1	ダイオード	DIODE ,AR :PA905C6-F	
1-26-5	S38203000	1	ダイオード	DIODE :YG8022C04R	
1-26-6	SA0037000	2	バリスタ	VARISTOR:V14D511	
1-26-7	232384001	1	サージアブソーバ	SURGE ABSORBER :DSA362MA	
1-26-8	S49071000	1	ダイオードブリッジ	DIODE BRIDGE :25XB60	
1-26-9	S38205000	2	コンデンサ	CAPACITOR, ALUM-ELEC 250B182	
1-26-10	SA1034000	1	コンデンサ	CAPACITOR, ALUM-ELEC 63B562	
1-26-11	S43175000	1	変圧器	TRANSFORMER :54AA159	
1-26-12	S43176000	1	変圧器	TRANSFORMER :35AD199	
1-26-13	S43181000	1	コイル	COIL :49AD289AC	
1-26-14	S38208000	1	リレー	RELAY :JW1AFSN/DC 5V	
1-26-15	153242000	2	ヒューズ	FUSE, 6A	
1-26-16	S08030000	1	ヒューズ	FUSE, 5A :FB	
1-26-17	S48580000	1	ヒューズ	FUSE, 7A :FB	
1-26-18	0A4301005	8	ネジ	SCREW, PAN (S/P WASHER) M3X10	
1-26-19	S43189000	1	PCBE1	PCB E1 HARNESS	
1-26-20	S43187000	1	PCBE2	PCB E2 HARNESS	
1-26-21	S49472000	1	サーミスタ	THERMISTOR :6D-22	
1-26-22	S49938000	1	絶縁シート	INSULATION SHEET	
10	S49477000	1	PROM制御	PROM CONTROL ASSY	
10-1	UA4817000	1	EPROM	EPROM:27C2001	
11	S53032000	1	PROM	PROM ASSY, IM	
11-1	S38143000	1	CMOSLSI	LSI:27C512	
12	228475000	1	結束バンド	TYING BAND 1.9X80	
20	S38352101	2	<輸出用> 電圧キタ	<For Export> LABEL, ELEC. SHOCK 4 LANG.	
21	S38353101	2	<国内用> 電圧キタ	<For Japan only> LABEL, ELEC. SHOCK JPN.	
54	S55627001	1	IMラベル	IM LABEL	

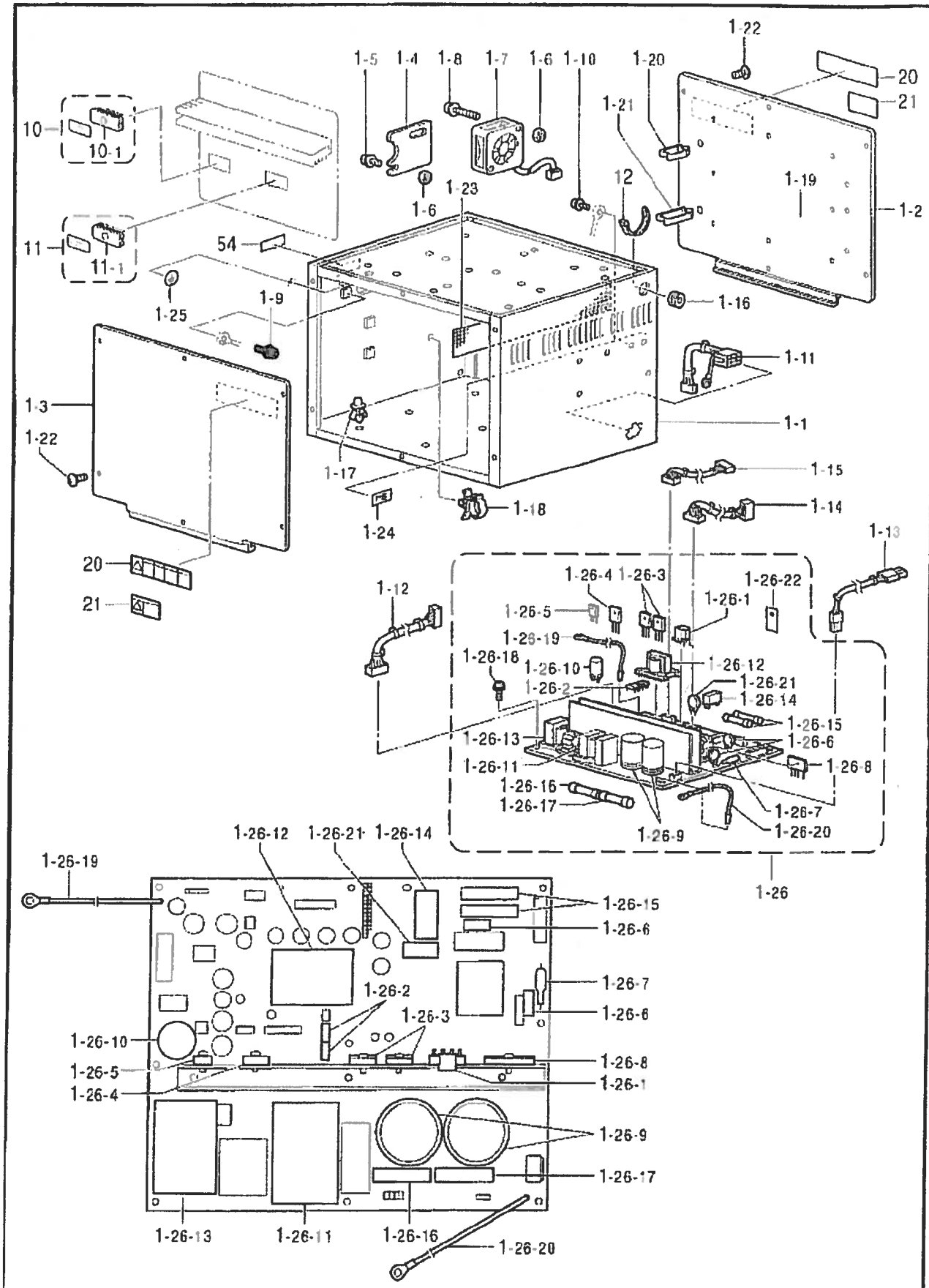

Q1. コントロールボックス関係 / Control box mechanism

REF.NO	CODE	QTY	品名	NAME OF PARTS	RM
H-1	S53031001	1	" 補給用部品 " <三相200V、220V用> ホツクスソクミA1-IM	" For supply parts " <For "3-Phse 200V & 220V AC"> BOX UNIT, A1-IM :3-P. 200/220V	*
H-2	S53033001	1	<单相200V、230V用> ホツクスソクミA2-IM	<For "1-Phse 200V & 230V AC"> BOX UNIT, A2-IM :1-P. 220/230V	*
H-3	S53034001	1	<单相100V用> ホツクスソクミB1-IM	<For Japan only> -----	*
H-4	S53035001	1	<单相110V、120V用> ホツクスソクミB2-IM	<For "1-Phse 110V & 120V AC"> BOX UNIT, B2-IM :1-P. 110V AC	*
H-5	S53036001	1	<三相415V用> ホツクスソクミC1-IM	<For "3-Phse 415V AC"> BOX UNIT, C1-IM :3-P. 415V AC	*
H-6	S53037001	1	<三相380V用> ホツクスソクミC2-IM	<For "3-Phse 380V AC"> BOX UNIT, C2-IM :3-P. 380V AC	*
H-7	S53038001	1	<单相240V用> ホツクスソクミC3-IM	<For "1-Phse 240V AC"> BOX UNIT, C3-IM :1-P. 240V AC	*
H-8	S53039001	1	<三相400V用> ホツクスソクミE-IM	<For "3-Phse 400V AC"> BOX UNIT, E-IM :3-P. 400V AC	*
H-9	S53040001	1	<单相240V用> ホツクスソクミF-IM	<For "1-Phse 240V AC"> BOX UNIT, F-IM :1-P. 230V AC	*

I18 B84-502

RM欄に*が付いている部品をご注文いただきますと、基板等必要な部品が一式入ったセットになっています。
When ordering parts which have an (*) in the RM column, these parts will be supplied as aset together with other necessary parts such as succul boards.

< 三相200V,220V用 / For "3-Phase 200V & 220V AC" >

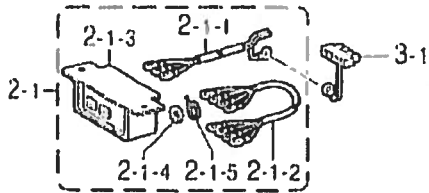

< 単相220V,230V用 / For "1-Phase 220V & 230V AC" >

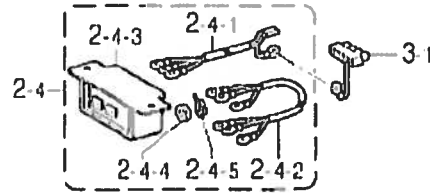

< 単相100V用 / For Japan only >

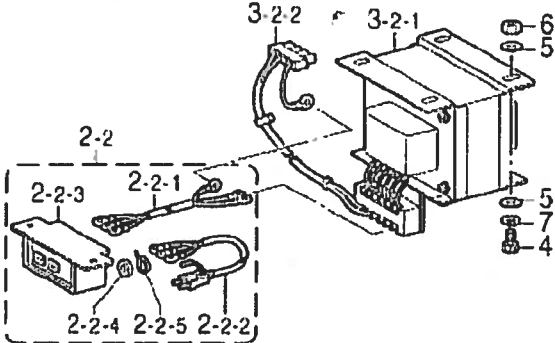

< 単相110V,120V用 / For "1-Phase 110V & 120V AC" >

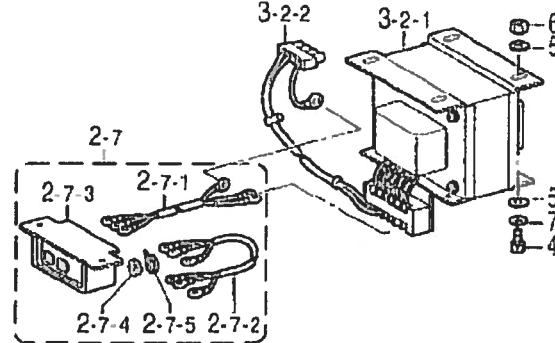

< 三相415V,380V用 / For "3-Phase 415V & 380V AC" >

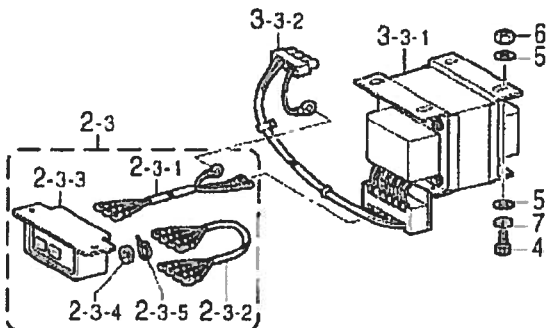

< 単相240V用 / For "1-Phase 240V AC" >

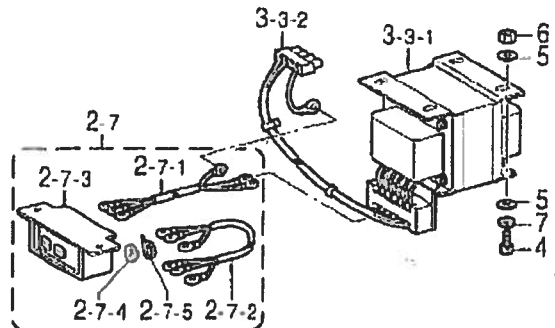

" オプション部品 / OPTION PARTS "

< 三相400V / For "3-Phase 400V AC" >

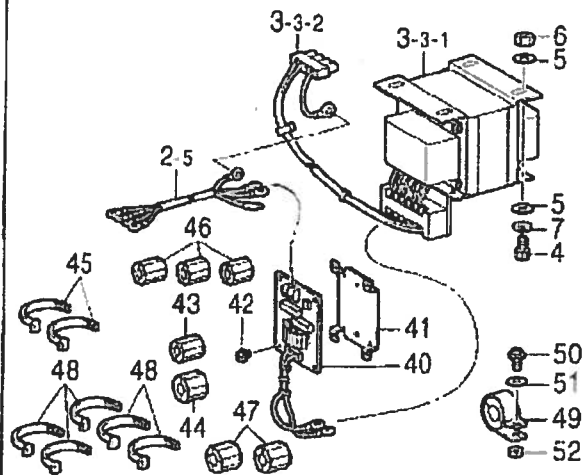

< 単相230V / For "1-Phase 230V AC" >

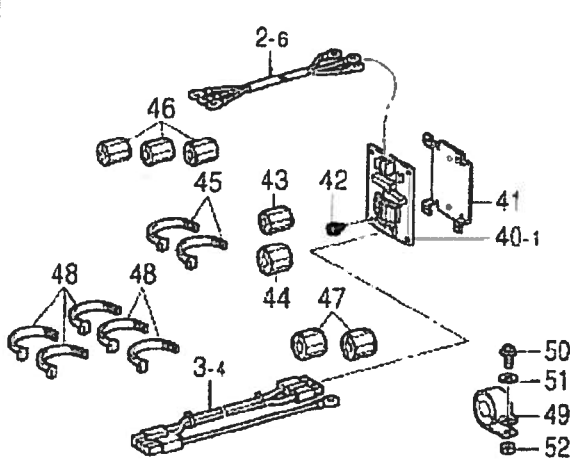

Q2. コントロールボックス関係 / Control box mechanism

REF.NO	CODE	Q'TY	ヒンメイ	NAME OF PARTS	RM
			<三相200V、220V用>	<For 3-Phase 200V & 220V AC>	
2-1	S38112001	1	テ'ン'ク'ンSW'ク'シA	POWER SUPPLY SWITCH ASSY, A	
2-1-1	S38113000	1	テ'ン'ク'ンIN'コ'ト'A	POWER SUPPLY IN HARNESS, A	
2-1-2	S38133000	1	テ'ン'ク'ン'コ'ト'	POWER SUPPLY HARNESS	
2-1-3	J02657001	1	3P'オ'シSW'17	3P. PUSH SWITCH, #17	
2-1-4	224514001	2	セ'ツ'イン'イ'ク'	INSULATION PLATE	
2-1-5	218859001	2	バ'イン'ク' M150	BINDER, M150	
			<单相100V用>	<For Japan only>	
2-2	S38114000	1	テ'ン'ク'ンSW'ク'シB	POWER SUPPLY SWITCH ASSY, B	
2-2-1	S38115000	1	テ'ン'ク'ンIN'コ'ト'B	POWER SUPPLY IN HARNESS, B	
2-2-2	S38118000	1	テ'ン'ク'ン'コ'ト'コ'ク'ナイ	POWER SUPPLY HARNESS, JPN.	
2-2-3	J02657001	1	3P'オ'シSW'17	3P. PUSH SWITCH, #17	
2-2-4	224514001	2	セ'ツ'イン'イ'ク'	INSULATION PLATE	
2-2-5	218859001	2	バ'イン'ク' M150	BINDER, M150	
			<三相415V、380V用>	<For 3-Phase 415V & 380V AC>	
2-3	S38117000	1	テ'ン'ク'ンSW'ク'シC	POWER SUPPLY SWITCH ASSY, C	
2-3-1	S38115000	1	テ'ン'ク'ンIN'コ'ト'B	POWER SUPPLY IN HARNESS, B	
2-3-2	S38133000	1	テ'ン'ク'ン'コ'ト'	POWER SUPPLY HARNESS	
2-3-3	J02657001	1	3P'オ'シSW'17	3P. PUSH SWITCH, #17	
2-3-4	224514001	2	セ'ツ'イン'イ'ク'	INSULATION PLATE	
2-3-5	218859001	2	バ'イン'ク' M150	BINDER, M150	
			<单相200V、230V用>	<For 1-Phase 200V & 230V AC>	
2-4	S47592000	1	テ'ン'ク'ンSW'ク'シD	POWER SUPPLY SWITCH ASSY, D	
2-4-1	S38113000	1	テ'ン'ク'ンIN'コ'ト'A	POWER SUPPLY IN HARNESS, A	
2-4-2	S47595000	1	テ'ン'ク'ン'コ'ト'ユ'シ'ツ	POWER SUPPLY HARNESS, EXP.	
2-4-3	J02657001	1	3P'オ'シSW'17	3P. PUSH SWITCH, #17	
2-4-4	224514001	2	セ'ツ'イン'イ'ク'	INSULATION PLATE	
2-4-5	218859001	2	バ'イン'ク' M150	BINDER, M150	
			" オプション部品 "	" OPTION PARTS "	
			<三相400V用>	<For 3-Phase 400V AC>	
2-5	S38120000	1	テ'ン'ク'ンIN'コ'ト'E	POWER SUPPLY IN HARNESS, E	
			<单相230V用>	<For 1-Phase 230V AC>	
2-6	S43188000	1	テ'ン'ク'ンIN'コ'ト'F	POWER SUPPLY IN HARNESS, F	
			<单相110V、120V、240V用>	<For 1-Phase 110V, 120V & 240V AC>	
2-7	S47594000	1	テ'ン'ク'ンSW'ク'シG	POWER SUPPLY SWITCH ASSY, G	
2-7-1	S38115000	1	テ'ン'ク'ンIN'コ'ト'B	POWER SUPPLY IN HARNESS, B	
2-7-2	S47595000	1	テ'ン'ク'ン'コ'ト'ユ'シ'ツ	POWER SUPPLY HARNESS, EXP.	
2-7-3	J02657001	1	3P'オ'シSW'17	3P. PUSH SWITCH, #17	
2-7-4	224514001	2	セ'ツ'イン'イ'ク'	INSULATION PLATE	
2-7-5	218859001	2	バ'イン'ク' M150	BINDER, M150	
			<单相220V、230V 三相200V、220V用>	<For 1-Phase 220V & 230V AC 3-Phase 200V & 220V AC>	
3-1	S38123000	1	ACIN'コ'ネ'ク'タ'	AC-IN CONNECTOR ASSY	
			<单相100V、110V、120V用>	<For 1-Phase 100V, 110V & 120V AC>	
3-2	S49473000	1	バ'ン'カ'ト'ラ'シ'ブ'シ'	CONVERSION TRANSFORMER ASSY, B	
3-2-1	S49474000	1	バ'ン'カ'ト'ラ'シ'ブ'	CONVERSION TRANSFORMER, B	
3-2-2	S38126000	1	ACIN'コ'ト'	AC-IN HARNESS	
				<For Japan only>	

< 三相200V,220V用 / For "3-Phase 200V & 220V AC" >

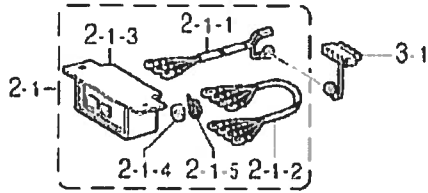

< 単相220V,230V用 / For "1-Phase 220V & 230V AC" >

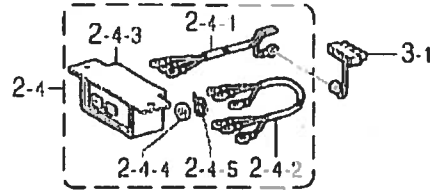

< 単相100V用 / For Japan only >

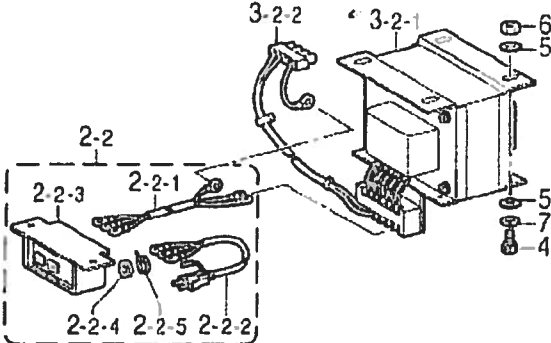

< 単相110V,120V用 / For "1-Phase 110V & 120V AC" >

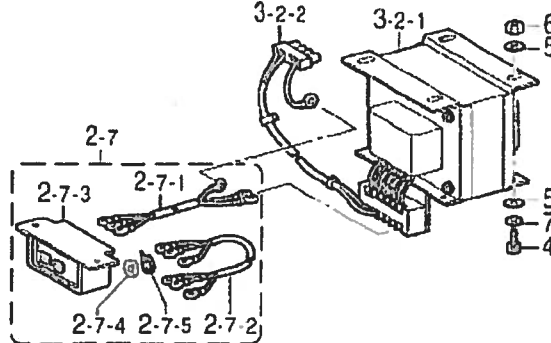

< 三相415V,380V用 / For "3-Phase 415V & 380V AC" >

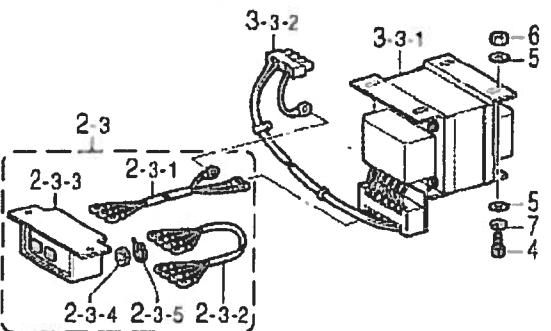

< 単相240V用 / For "1-Phase 240V AC" >

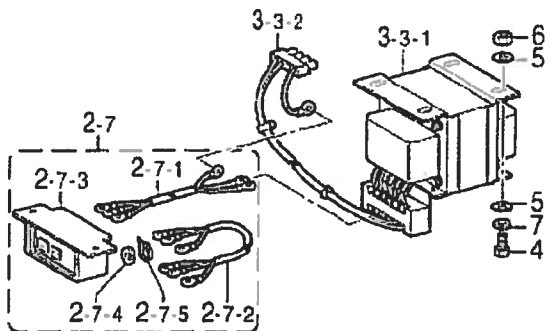

" オプション部品 / OPTION PARTS "

< 三相400V / For "3-Phase 400V AC" >

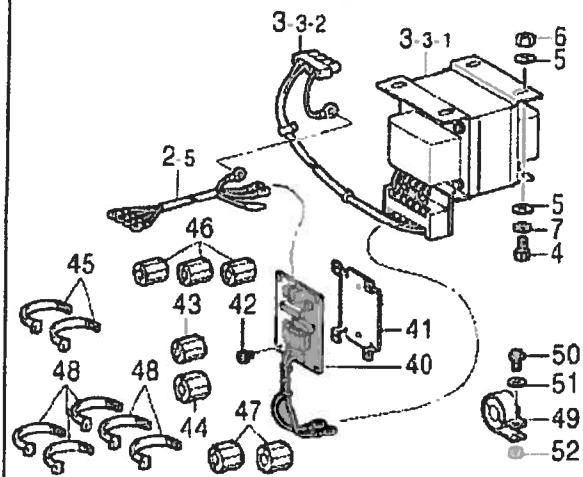

< 単相230V / For "1-Phase 230V AC" >

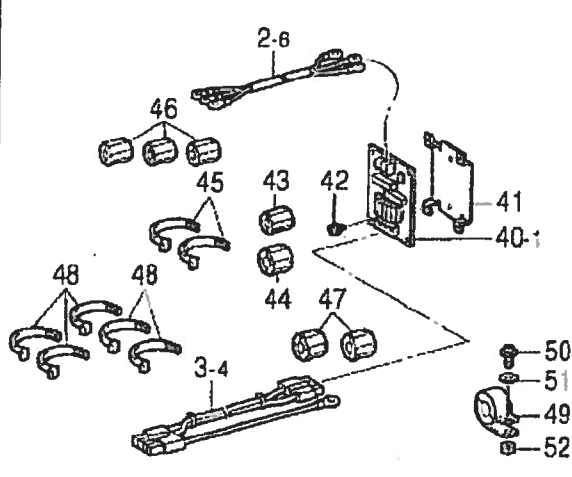

Q2. コントロールボックス関係 / Control box mechanism

REF.NO	CODE	Q'TY	ヒンメイ	NAME OF PARTS	RM
3-3	S49475000	1	<単相240V 三相400V、415V、380V用> コンバータ変圧器	<For 1-Phase 240V AC 3-Phase 400V, 415V & 380V AC> CONVERSION TRANSFORMER ASSY, C	
3-3-1	S49476000	1	コンバータ変圧器	CONVERSION TRANSFORMER, C	
3-3-2	S38126000	1	ACインコネクタ	AC-IN HARNESS	
3-4	S43201000	1	"オプション部品" <単相230V用> ACインコネクタF	"OPTION PARTS" <For 1-Phase 230V AC> AC-IN HARNESS, F	
4	018061436	4	<単相200V, 220V, 230V以外> ボルトM6X14	<Except for 200V, 220V & 230V AC> BOLT, SOCKET M6X14	
5	025060236	8	ワッシャーM6	WASHER, PLAIN M 6	
6	021060106	4	ナットM6	NUT, 1 M6	
7	028060246	4	ワッシャーM6	WASHER, SPRING 2-6	
40	S40635001	1	"オプション部品" <三相400V用> ノイズフィルタ430E	"OPTION PARTS" <For 3-Phase 400V AC> NOISE FILTER ASSY, 430E	
40-1	S40616001	1	<単相230V用> ノイズフィルタEMC	<For 1-Phase 230V AC> NOISE FILTER ASSY, EMC	
41	S40620000	1	<単相230V, 三相400V用> PCB調整プレート	<For 1-Phase 230V AC & 3-Phase 400V AC> PCB SETTING PLATE	
42	0A4400605	6	ネジM4X6DA	SCREW, PAN (S/P WASHER) M4X6	
43	S40621000	1	EMIコアESD-SR-15	EMI CORE, ESD-SR-15	
44	S40622000	1	EMIコアESD-SR-25	EMI CORE, ESD-SR-25	
45	149809000	2	ビーズバンドL	BEAD BAND, L=200	
46	S40621000	3	EMIコアESD-SR-15	EMI CORE, ESD-SR-15	
47	S40622000	2	EMIコアESD-SR-25	EMI CORE, ESD-SR-25	
48	149809000	5	ビーズバンドL	BEAD BAND, L=200	
49	S40623000	1	EMIコアTR-40-27	EMI CORE, TR-40-27	
50	0A5401606	1	ネジM4X16DB	SCREW, PAN (S/P WASHER) M4X16	
51	025040236	1	ワッシャーM4	WASHER, PLAIN M 4	
52	021400106	1	ナットM4	NUT, 1 M4	

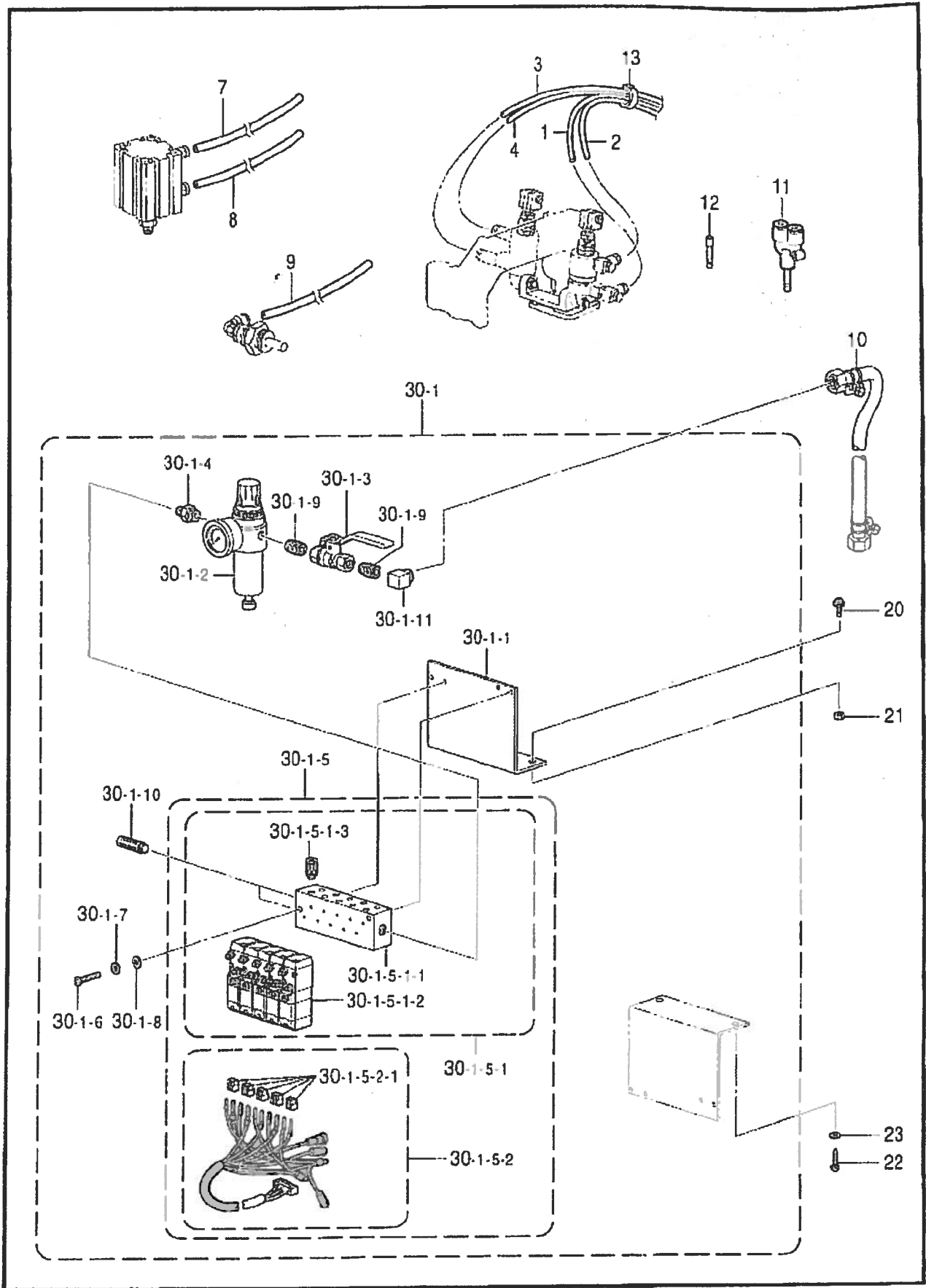

R. 空圧関係 / Air pressure mechanism

REF.NO	CODE	QTY	ヒンメイ	NAME OF PARTS	RM
1	S43687001	1	ナイロンチューブR	AIR TUBE, R	
2	S43687002	1	ナイロンチューブR	AIR TUBE, R	
3	S43688001	1	ナイロンチューブL	AIR TUBE, L	
4	S43688002	1	ナイロンチューブL	AIR TUBE, L	
7	S18387006	1	エアチューブ	AIR TUBE, 4 L	
8	S18387006	1	エアチューブ	AIR TUBE, 4 L	
9	S18387006	1	エアチューブ	AIR TUBE, 4 L	
10	149796001	1	ゴムホースカクツキ	AIR HOSE, W/CONNECTOR	
11	S08178000	2	ブランチUY-4	BRANCH, UY-4	
12	S04897000	1	プラグ4	PLUG, 4	
13	228475000	3	ケツツクバンド1.9X80	TYING BAND 1.9X80	
20	0A5501205	2	ナハサツミ5X12DB	SCREW, PAN (S/P WASHER) M5X12	
21	021500106	2	1シコナツト5	NUT, 1 M5	
22	032422003	2	ナハモクネシ4.1X20	WOOD SCREW, ROUND M4.1X20	
23	148847001	2	ワシカネ	WASHER, PLAIN 4.76	
30-1	S57879001	1	ソレノイドバルブ5Aクミ	SOLENOID VALVE ASSY, 5A	
30-1-1	S57695001	1	バルブトリツケイタ5-6	VALVE SETTING PLATE, 5-6	
30-1-2	S09318101	1	インテグレータ	INTEGRATOR	
30-1-3	S40628000	1	ボールバルブ1/4	BALL VALVE, 1/4	
30-1-4	S09228000	1	イケニツツル	NIPPLE, 1/4X1/8	
30-1-5	S57880001	1	ソレノイドバルブ5クミ	SOLENOID VALVE ASSY, 5	
30-1-5-1	S57881001	1	エアマニホールド5クミ	AIR MANIFOLD ASSY, 5	
30-1-5-1-1	S57882001	1	エアマニホールド5	AIR MANIFOLD, 5	
30-1-5-1-2	S43683001	5	ソレノイドバルブ	SOLENOID VALVE	
30-1-5-1-3	S18415101	10	ハーフユニオンQ4M5	HALF UNION :Q4M5	
30-1-5-2	S57883001	1	バルブハネスX5クミ	VALVE HARNESS ASSY, X5	
30-1-5-2-1	S12404000	5	クワタバルブコネクタ	VALVE CONNECTOR	
30-1-6	062302506	2	ナハコ3X25	SCREW, PAN M3X25	
30-1-7	028030242	2	ナハコネ2-3	WASHER, SPRING 2-3	
30-1-8	025030232	2	ヒラサカネ203	WASHER, PLAIN M 3	
30-1-9	S40629000	2	バルブニツツル	BARREL NIPPLE	
30-1-10	S23880000	2	エアマフラー	AIR MUFFLER	
30-1-11	S43686000	1	PTILホ1/4	ELBOW, PT 1/4	

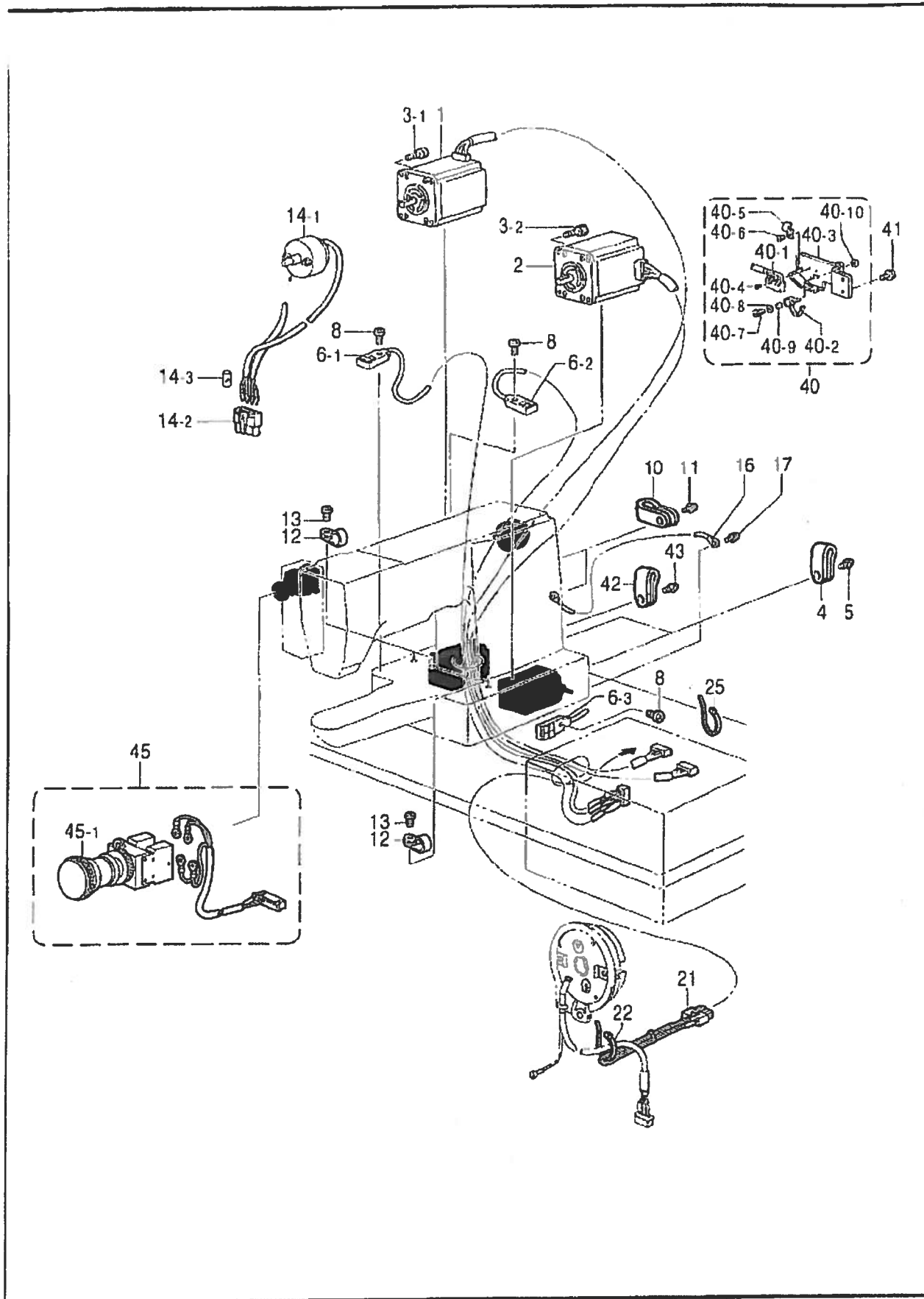

S. 電装品関係 / Power supply equipment mechanism

REF NO	CODE	QTY	品名	NAME OF PARTS	RM
1	S48587000	1	パルスモータXクミ	PULSE MOTOR ASSY, X	
2	S48589000	1	パルスモータYクミ	PULSE MOTOR ASSY, Y	
3-1	155055001	4	アナホルト4X45	BOLT, SOCKET M4X45	
3-2	018402522	4	アナホルト4X25	BOLT, SOCKET M4X25	
4	552907000	2	コードホルダ #10	CORD HOLDER, 10N	
5	0A5401006	2	ナハコハ社ラ4X10	SCREW, PAN (S/P WASHER) M4X10	
6	S57710001	1	トウアセンサIアークミ	HEAD SENSOR AIR ASSY	
6-1	S56167000	1	キンセブセンサGL-N12F	PROXIMITY SENSOR, GL-12NF	
6-2	S56167001	1	キンセブセンサGL-N12F	PROXIMITY SENSOR, GL-12NF	
6-3	S56167001	1	キンセブセンサGL-N12F	PROXIMITY SENSOR, GL-12NF	
8	062300806	3	ナハコ3X8	SCREW, PAN M3X8	
10	552907000	2	コードホルダ #10	CORD HOLDER, 10N	
11	0A5401006	2	ナハコハ社ラ4X10	SCREW, PAN (S/P WASHER) M4X10	
12	625010000	3	ナイロンクランプNK-2N	NYLON CLAMP NK-2N	
13	062670512	3	ナハコ357-40X5	SCREW, PAN SM3.57-40X5	
14-1	S38144100	1	イトキリソレノイドクミ	THREAD TRIMMER SOLENOID ASSY	
14-2	S38146000	1	コネクタ3191-04R	CONNECTOR :3191-04R	
14-3	S38147000	1	マークチューブ5	MARK TUBE, 5	
16	S38148000	1	アース線1	GROUND WIRE, 1	
17	0A5400806	1	ナハコザクミ4X8DB	SCREW, PAN (S/P WASHER) M4X8	
21	S49465008	1	コネクタIコネクタクミ	CONNECTOR ASSY	
22	228475000	1	タイピングバンド1.9X80	TYING BAND 1.9X80	
25	218859001	1	バインダM150	BINDER, M150	
40	S55629101	1	トウアスイッチクミ	HEAD SEITCH ASSY	
40-1	S55630001	1	マイクロスイッチクミ	MICRO SWITCH ASSY	
40-2	S38744101	1	スイッチプレート	SWITCH PLATE SPRING	
40-3	S55632001	1	スイッチブラケット	SWITCH BRACKET	
40-4	062020806	2	ナハコ2X8	SCREW, PAN M2X8	
40-5	140647101	1	コードホルダ	CORD HOLDER	
40-6	062400616	1	ナハコM4X6	SCREW, PAN M4X6	
40-7	062401216	1	ナハコM4X12	SCREW, PAN M4X12	
40-8	026040236	1	ヒラサカ平ネジ4	WASHER, PLAIN 4	
40-9	154514001	1	スペーサ	SPACER	
40-10	021400106	1	ナット1.5M4	NUT, 1 M4	
41	0A5401006	2	ナハコハ社ラ4X10	SCREW, PAN (S/P WASHER) M4X10	
42	552907000	1	コードホルダ #10	CORD HOLDER, 10N	
43	0A5401006	1	ナハコハ社ラ4X10	SCREW, PAN (S/P WASHER) M4X10	
45	S57878001	1	EMロックスイッチクミ	EM-LOCK SWITCH ASSY	
45-1	S52744000	1	スイッチA22E-M-11	SWITCH, A222E-M-11	

Γ . 操作パネル関係 / Operation panel mechanism

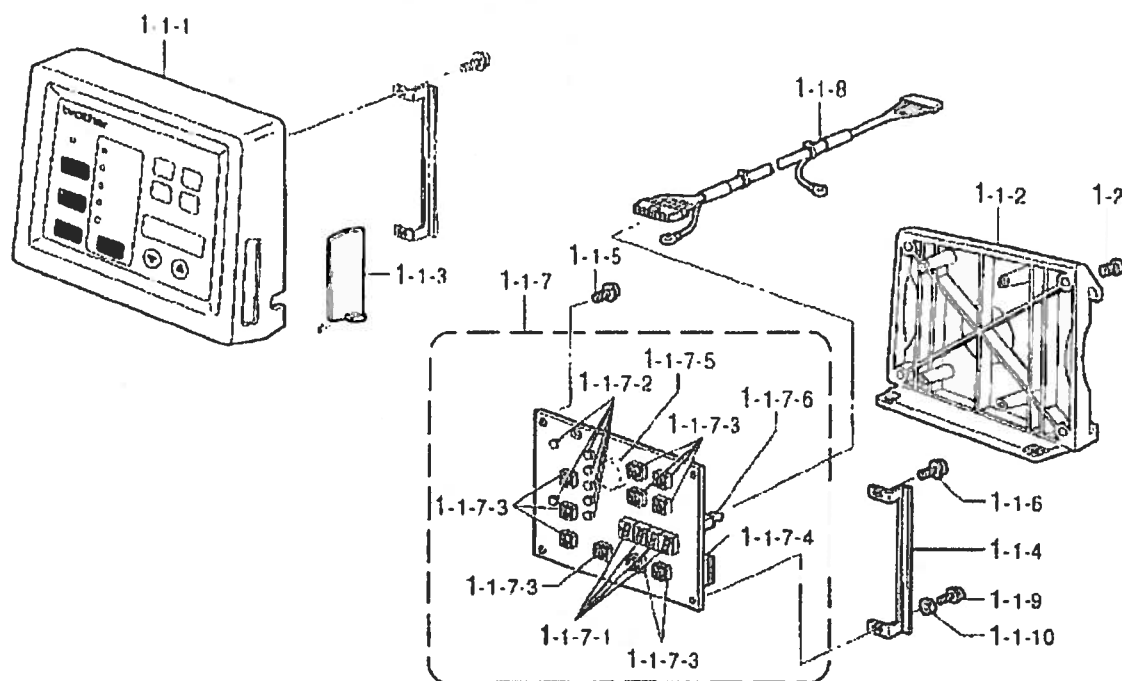

118-B84-530

U . 動力台関係 / Power table

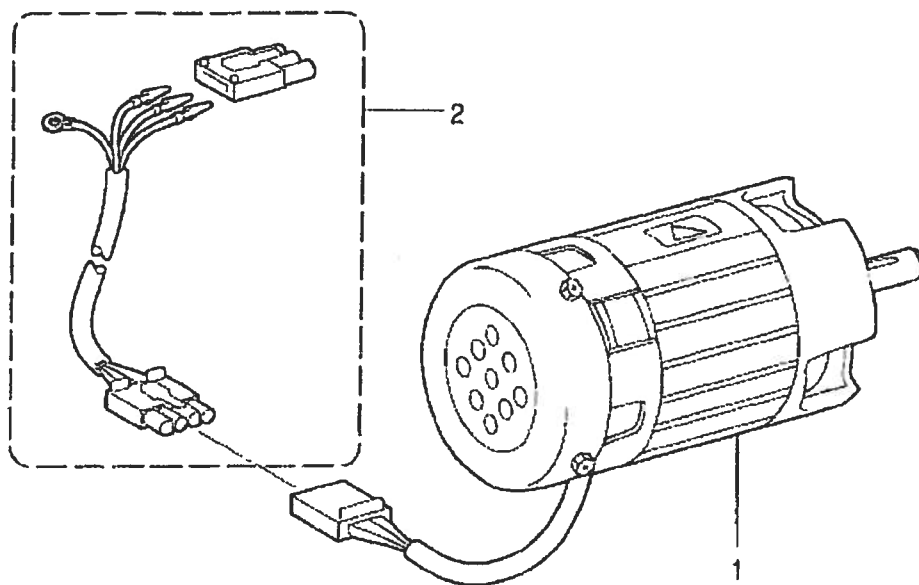

118-B84-652

T. 操作パネル関係 / Operation panel mechanism

REF.NO	CODE	QTY	ヒンメイ	NAME OF PARTS	RM
1	S55889001	1	ソウザハ ^ネ ノクミ	OPERATION PANEL UNIT	
1-1	S55890001	1	ソウザハ ^ネ IMクミ	OPERATION PANEL ASSY, IM	
1-1-1	S55891000	1	マI7レ-ムIMクミ	FRONT FRAME ASSY, IM	
1-1-2	S52091000	1	ウシロ7レ-ムクミ	REAR FRAME ASSY	
1-1-3	S49495000	1	ハ ^ネ ネヨコカハ ^ネ	PANEL SIDE COVER	
1-1-4	S49496001	1	ハ ^ネ ネヨコカハ ^ネ -ガイト	PANEL SIDE COVER GUIDE	
1-1-5	0B7310B15	2	カツ7 ^ネ Bタイ3X8	TAPTITE, CUP B M3X8	
1-1-6	0A4400805	1	ナハ ^ネ サ ^ネ クミ4X8DA	SCREW, PAN (S/P WASHER) M4X8	
1-1-7	S49497001	1	ハ ^ネ ネキハンクミ	PANEL PCB ASSY	
1-1-7-1	S29023000	4	LEDGL9P040	LED :GL9P040	
1-1-7-2	S46703000	7	LEDPG5307S	LED :PG5307S	
1-1-7-3	S48579000	10	SWB3F-4050	SWITCH :B3F-4050	
1-1-7-4	U34870001	1	DIPSW KSP08	DIP SWITCH:KSP08	
1-1-7-5	S30280000	1	ブ ^サ -PKB24SPC36	BUZZER :PKB24SPC36	
1-1-7-6	UL0025000	1	コネクタ3429-6002SC	CONNECTOR:3429-6002SC	
1-1-8	S49510000	1	ハ ^ネ ネウ-フ ^ネ クミ	PANEL HARNESS ASSY	
1-1-9	0B7311015	2	カツ7 ^ネ Bタイ3X10	TAPTITE, CUP B M3X10	
1-1-10	XA2220050	2	ネハンオサI	PCB HOLDER	
1-2	062300806	4	ナハ ^ネ コ3X8	SCREW, PAN M3X8	

118-B84-530

U. 動力台関係 / Power table

REF.NO	CODE	QTY	ヒンメイ	NAME OF PARTS	RM
1	J80868001	1	CIMモ-タ430クミホ	CIM MOTOR ASSY, 430	
2	S53055100	1	IMハ-ネスクミ	HARNESS ASSY, IM	

118-B84-652

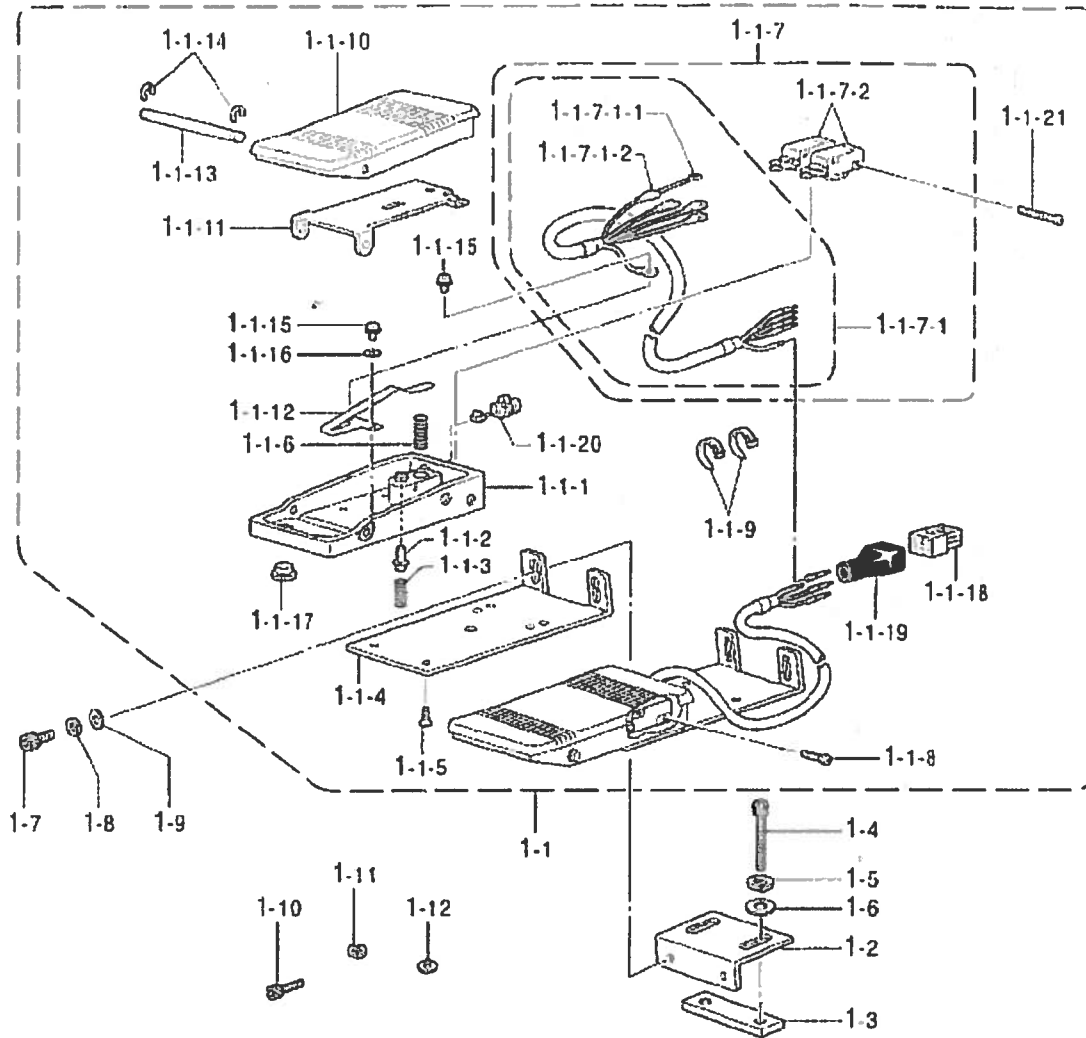

V1. 踏板関係 / Foot switch pedal mechanism

REF NO	CODE	QTY	品名	NAME OF PARTS	RM
1	S51846101	1	2レンフト3SWセット	2-PEDAL FOOT SWITCH SET, 3	
1-1	S51847101	1	2レンフト3SWクミ	2-PEDAL FOOT SWITCH ASSY, 3	
1-1-1	S49669100	2	フットペダルベースイタ	FOOT PEDAL BASE ASSY	
1-1-2	S49672001	1	2ステップSWピン	2-STEP SWITCH PIN	
1-1-3	S38168001	1	アッソシエイト	SPRING, COMPRESSION 10X30	
1-1-4	S38169201	2	フットSW支持板	FOOT SWITCH SUPPORT PLATE, B	
1-1-5	004400603	4	平頭ネジ M4X6	SCREW, FLAT M4X6	
1-1-6	S38170001	2	フットペダルバネ	FOOT PEDAL SPRING	
1-1-7	S54650000	1	2レンフト3SWハーネス	2-PEDAL F-SWITCH HARNESS ASSY	
1-1-7-1	S54691000	1	2レンフト3SWハーネス	2-PEDAL FOOT SWITCH HARNESS	
1-1-7-1-1	S54644000	6	雌コネクタ	TERMINAL, FEMALE	
1-1-7-1-2	S54645000	6	絶縁カバー	INSULATION COVER	
1-1-7-2	S36260000	3	スイッチVXピンボタン	MICRO SWITCH, VX PIN BUTTON	
1-1-8	062301205	2	ネジ M3X12	SCREW, PAN M3X12	
1-1-9	228475000	8	タイピングバンド 1.9X80	TYING BAND 1.9X80	
1-1-10	S51451000	2	フットペダル	FOOT PEDAL	
1-1-11	S49673000	2	ペダル保護板	PEDAL PROTECTION PLATE	
1-1-12	S49674001	2	スイッチ押しバネ	SWITCH PRESSER SPRING	
1-1-13	S38177001	2	フットペダルシャフト	FOOT PEDAL SHAFT	
1-1-14	048050346	4	留め輪 E5	RETAINING RING, E5	
1-1-15	052400606	4	ネジ M4X6	SCREW, PAN (S/P WASHER) M4X6	
1-1-16	025040236	2	ワッシャー M4	WASHER, PLAIN M 4	
1-1-17	117936001	8	ゴムキャップ 9.4	RUBBER CAP, 9.4	
1-1-18	S38180000	1	コネクタ 172169-1	CONNECTOR :172169-1	
1-1-19	S38060000	1	コネクタキャップ 18X19	CONNECTOR CAP, 18X19	
1-1-20	S46694000	2	コードブッシュ KR61A	CORD BUSH :KR61A	
1-1-21	062302506	2	ネジ M3X25	SCREW, PAN M3X25	
1-2	S38178101	2	フットSW支持板 A	FOOT SWITCH SUPPORT PLATE, A	
1-3	S38179101	2	フットSW支持板 C	FOOT SWITCH SUPPORT PLATE, C	
1-4	018082536	4	ボルト M8X25	BOLT, SOCKET M8X25	
1-5	028080246	4	ワッシャー M2-8	WASHER, SPRING 2-8	
1-6	025080236	4	ワッシャー M8	WASHER, PLAIN M 8	
1-7	018501036	4	ボルト M5X10	BOLT, SOCKET M5X10	
1-8	028050246	4	ワッシャー M2-5	WASHER, SPRING 2-5	
1-9	025050236	4	ワッシャー M5	WASHER, PLAIN M 5	
1-10	018401236	4	ボルト M4X12	BOLT, SOCKET M4X12	
1-11	028040246	4	ワッシャー M2-4	WASHER, SPRING 2-4	
1-12	025040236	4	ワッシャー M4	WASHER, PLAIN M 4	

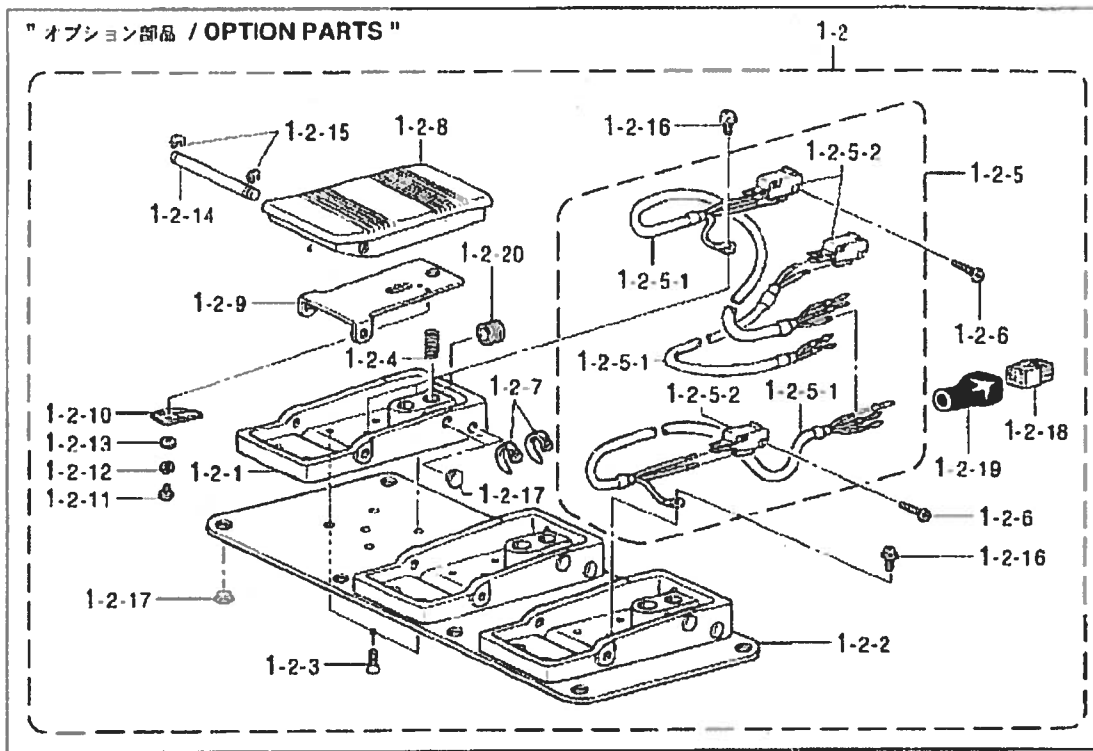

< 補給用部品 / For supply parts >

V2. 踏板関係(オプション部品) / Foot switch pedal mechanism (Option parts)

REFNO	CODE	QTY	ヒンメイ	NAME OF PARTS	RM
1-2	S44805101	1	3レンフト3SW	3-PEDAL FOOT SWITCH, 3	
1-2-1	S38166000	3	フットペダルベース	FOOT PEDAL BASE	
1-2-2	S42867001	1	フミイタ補助プレート	TREADLE AUXILIARY PLATE	
1-2-3	004400603	6	ボルトM4X6	SCREW, FLAT M4X6	
1-2-4	S38170001	3	フットペダルバネ	FOOT PEDAL SPRING	
1-2-5	S44806000	1	3レンフトSWハーネス	3-PEDAL FOOT SW HARNESS ASSY	
1-2-5-1	S44807000	1	3レンフトSWハーネス	3-PEDAL FOOT SW HARNESS	
1-2-5-2	S36260000	3	マイクロスイッチ	MICRO SWITCH, VX:PIN BUTTON	
1-2-6	0C2301205	6	ネジM3X12	SCREW, PAN M3X12	
1-2-7	228475000	10	タイピングバンド	TYING BAND 1.9X80	
1-2-8	S38174000	3	フットペダル	FOOT PEDAL	
1-2-9	S38175001	3	ペダル保護プレート	PROTECTION PLATE, PEDAL	
1-2-10	S38176101	3	バネプレート	SPRING, PLATE	
1-2-11	002300403	6	ネジM3X4	SCREW, PAN M3X4	
1-2-12	028030246	6	ワッシャー	WASHER, SPRING 2-3	
1-2-13	025030236	6	ワッシャー	WASHER, PLAIN M 3	
1-2-14	S38177001	3	フットペダルシャフト	FOOT PEDAL SHAFT	
1-2-15	048050346	6	リング	RETAINING RING, E5	
1-2-16	052400606	2	ネジM4X6	SCREW, PAN (S/P WASHER) M4X6	
1-2-17	117936001	14	ゴムキャップ	RUBBER CAP, 9.4	
1-2-18	S38180000	1	コネクタ	CONNECTOR :172169-1	
1-2-19	S38060000	1	コネクタキャップ	CONNECTOR CAP, 18X19	
1-2-20	S38059000	3	ゴムキャップ	RUBBER CAP, NG79F	
3	S49443000	1	補給用部品 コンタクト	For supply parts CONTACT :170364-1	

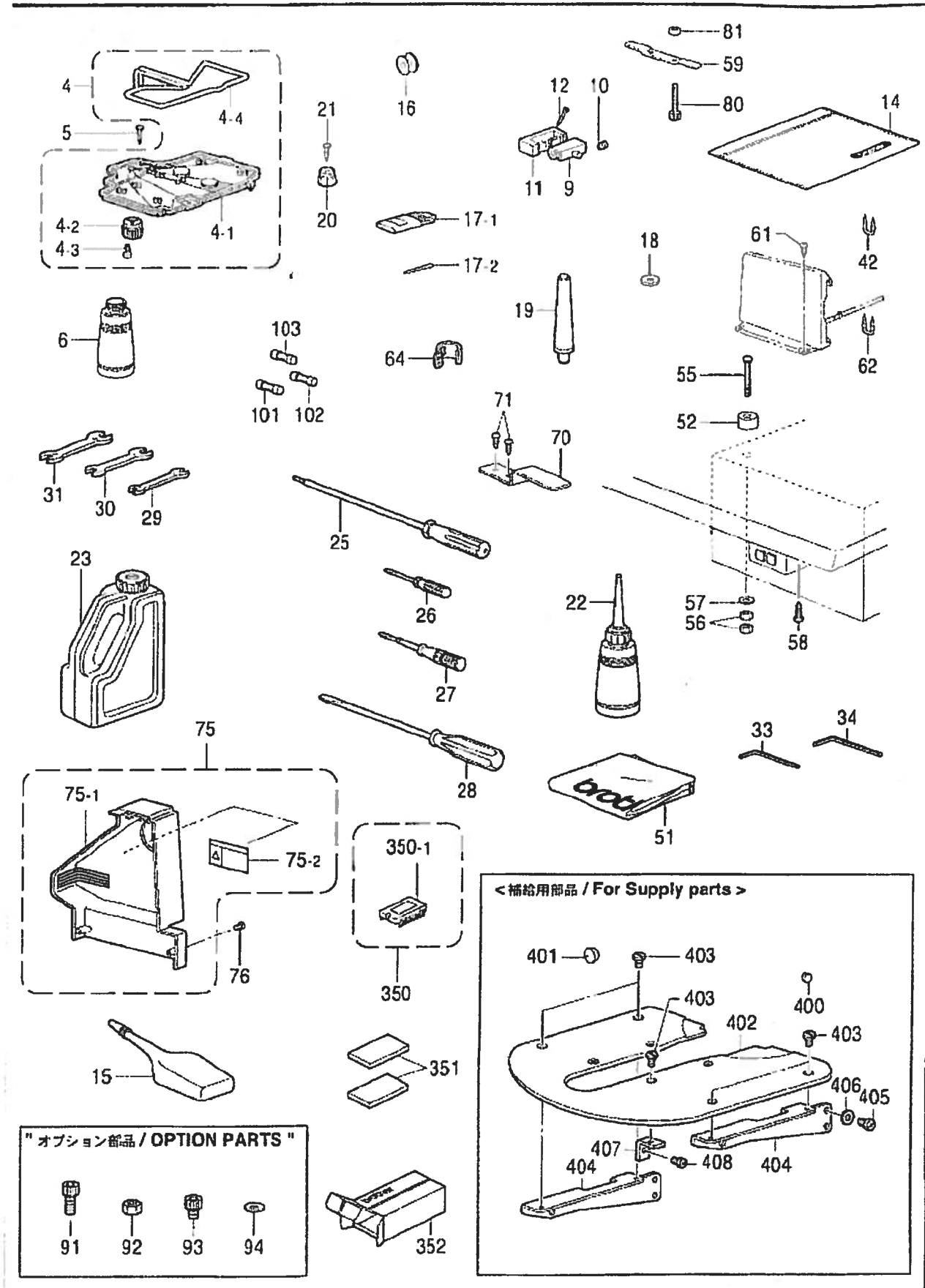

Z1. 付属品関係 / Accessories

REF.NO	CODE	QTY	品名	NAME OF PARTS	RM
4	S38039209	1	オイルパン	OIL PAN ASSY	
4-1	S38040209	1	オイルパン	OIL PAN	
4-2	154467001	1	ハイキヤツブ	DUST OILER	
4-3	037301215	2	Vナヘクツビ 3X12	TAPPING SCREW, PAN V M3X12	
4-4	S18093100	1	ワジキ 4X4	WICK, 4X4 L=1100	
5	109714000	5	ナギ	NAIL	
6	114486002	1	ホリオリイ	OILER	
9	143882001	2	トウフヒンジ	HEAD HINGE	
10	014760622	2	アトメシ 5.95	SET SCREW, SOCKET SM5.95	
11	S49603000	2	トウフヒンジウケゴム	RUBBER CUSHION	
12	109714000	4	ナギ	NAIL	
14	122991001	1	アソクヒンボリフカ	ACCESSORY BAG	
15	S06706001	1	シリコンオイル	SILICONE OIL	
16	S00871101	3	ホビ	BOBBIN, B	
17-1	SA1645025	1	145646/140コリクミ	NEEDLE 4PIECE ASSY, 145646	
17-2	S24511007	10	ミシンノミ 3355-01MR	NEEDLE, 3355-01 MR	
18	S10208001	1	トウフハカシ <t=0.4>	MOVABLE KNIFE SPACER <t=0.4>	
18	S10208002	1	トウフハカシ <t=0.5>	MOVABLE KNIFE SPACER <t=0.5>	
18	S10208003	1	トウフハカシ <t=0.6>	MOVABLE KNIFE SPACER <t=0.6>	
19	S38045109	1	マクラ	HEAD REST ASSY	
20	S49604000	2	トウフウケゴム	RUBBER CUSHION	
21	109714000	2	ナギ	NAIL	
22	114483002	1	ホリオリイ	OILER ASSY	
23	S55663001	1	オイルタンク	OIL TANK ASSY	
25	149173001	1	6カクホウネン マワシ 3	SCREW-DRIVER, HEXAGONAL 3	
26	142443001	1	ネン マワシ 1.9X52	SCREW-DRIVER, 1.9X52	
27	118837001	1	ネン マワシ 3.4X70	SCREW-DRIVER, 3.4X70	
28	101572101	1	ネン マワシ 5.5X190	SCREW-DRIVER, 5.5X190	
29	107779001	1	スナナ 6X7	WRENCH, 6X7	
30	100887001	1	スナナ 8X9	WRENCH, 8X9	
31	107780001	1	スナナ 10X12	WRENCH, 10X12	
33	142721001	1	6カクホウスナナ 3	HEXAGONAL WRENCH, 3	
34	118064001	1	6カクホウスナナ 4	HEXAGONAL WRENCH, 4	
42	200190001	5	ステツル	STAPLE	
51	144226001	1	トウフカバー	HEAD COVER	
			<コントロールBox取付用>	<Setting the control box>	
52	S33006001	4	モータスペース	MOTOR SPACER	
55	133740006	4	カクネボルト 6X70	BOLT, SQUARE M6X70	
56	021060106	8	1シユナツト 6	NUT, 1 M6	
57	025060336	4	ヒラサガネダイ 6	WASHER, PLAIN L 6	
			<電源SW取付用>	<Setting the power switch>	
58	032461606	2	ナギ 4.5X16	WOOD SCREW, ROUND M4.5X16	
59	S38044001	1	ヒンジオサ	HINGE PRESSER	
61	032422505	4	ナギ 4.1X25	WOOD SCREW, ROUND M4.1X25	
62	200190001	3	ステツル	STAPLE	
64	S41222101	1	ハリネウイトアンバ	NEEDLE BAR THREAD GUIDE, B	
70	S55633001	1	スイッチプレート	SWITCHING PLATE	
71	032422003	2	ナギ 4.1X20	WOOD SCREW, ROUND M4.1X20	

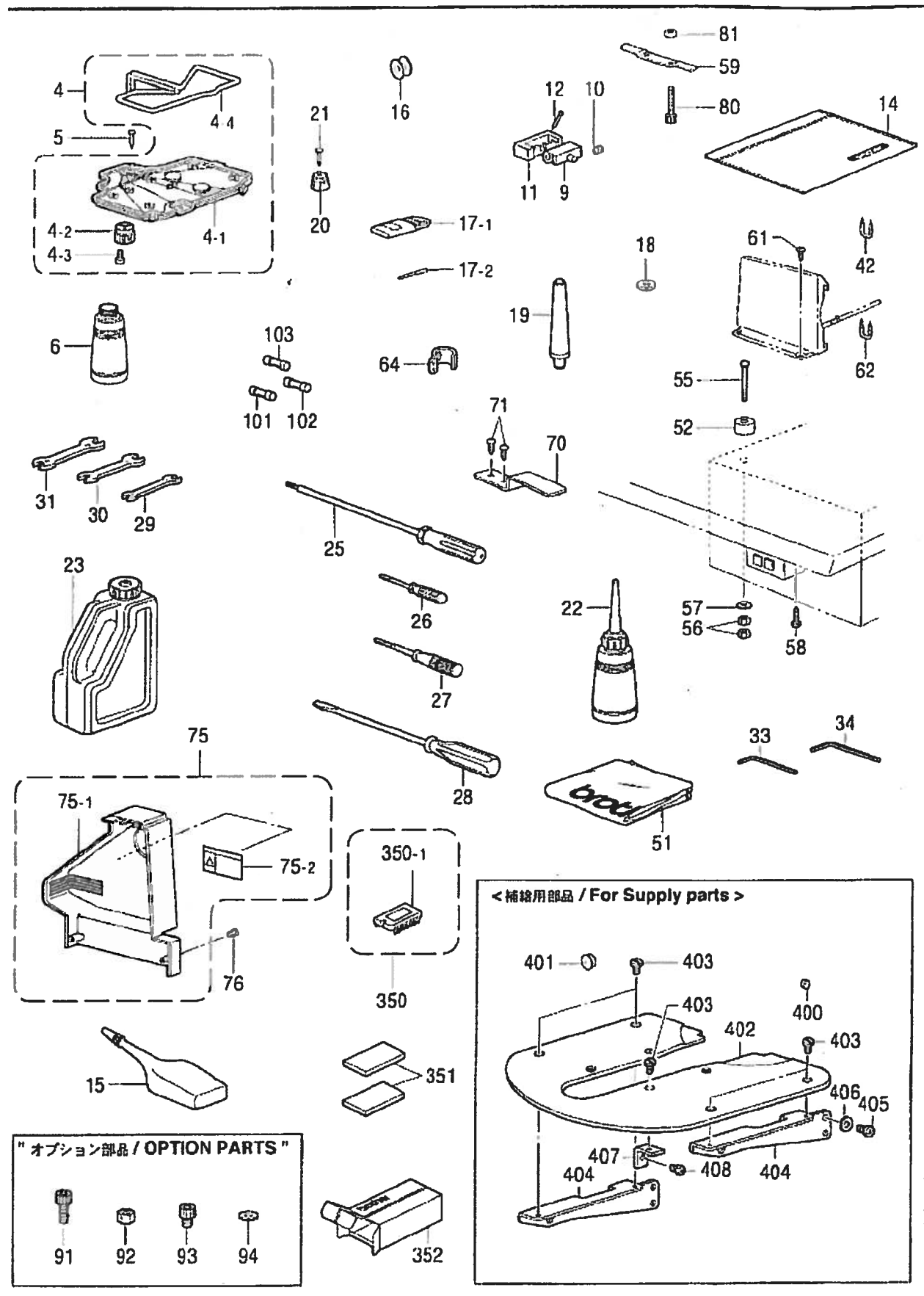

Z1. 付属品関係 / Accessories

REF NO	CODE	QTY	ヒンメイ	NAME OF PARTS	RM
			<国内用>	<For Japan only>	
75	S55311001	1	ベルトカバー-IM7ミ	BELT COVER ASSY, IM	
75-1	S51097000	1	ベルトカバー-IM	BELT COVER, IM	
75-2	S38350001	1	ワザコウイラベル. J	LABEL, OPERATION JPN.	
			<輸出用>	<For Export>	
75	S55311002	1	ベルトカバー-IM7ミ	BELT COVER ASSY, IM	
75-1	S51097000	1	ベルトカバー-IM	BELT COVER, IM	
75-2	S38349001	1	ワザコウイラベル. E	LABEL, OPERATION ENG.	
76	062401006	2	ネジ J4X10	SCREW, PAN M4X10	
80	018405032	2	アボルト4X50	BOLT, SOCKET M4X50	
81	021400102	2	ナット1シユ4	NUT, 1 M4	
			" オプション部品 "	" OPTION PARTS "	
91	S59893001	1	アボルト4.37X40X10	BOLT, SOCKET SM4.37X40X10	
92	021680202	1	ナット2シユ4.37	NUT, 2 SM4.37	
93	S59892001	4	アボルト4.37X40X5	BOLT, SOCKET SM4.37X40X5	
94	025680232	2	ヒラサカワザコウ4.37	WASHER, PLAIN M 4.37	
101	S08030000	1	ヒューズ5AFB	FUSE, 5A :FB	
102	153242000	1	ヒューズ6A	FUSE, 6A	
103	S48580000	1	GFUSE7AFB	FUSE, 7A :FB	
350	S51844000	1	PROMキット 34347ミ	PROM ASSY, CONTROL 434	
350-1	UA4817000	1	MOSLS1 27C2001	EPROM:27C2001	
351	S60400000	2	トウテンパッド30X50	CONDUCTIVE PAD, 30X50	
352	S60711001	1	PROM 1レハコ	PROM CARTON BOX	
			" 補給用部品 "	" For Supply parts "	
400	104450101	1	ゴムキャップ	RUBBER CAP, 8	
401	140392009	1	オイルキャップ	OIL CAP	
402	S51461001	1	ハリタネシヨウ	NEEDLE PLATE AUXILIARY PLATE	
403	106629002	8	シメネジ 4.37	SCREW, SM4.37	
404	S51459001	2	ネジシヨウサエ	AUXILIARY PLATE SUPPORT	
405	062761012	4	ネジ J595-28X10	AUXILIARY PLATE SUPPORT	
406	025060232	4	ヒラサカワザコウ6	AUXILIARY PLATE SUPPORT	
407	S10091201	4	ハリタネシヨウサエ	AUXILIARY PLATE SUPPORT	
408	062680812	4	ネジ J437-40X8	SCREW, PAN SM4.37-40X8	

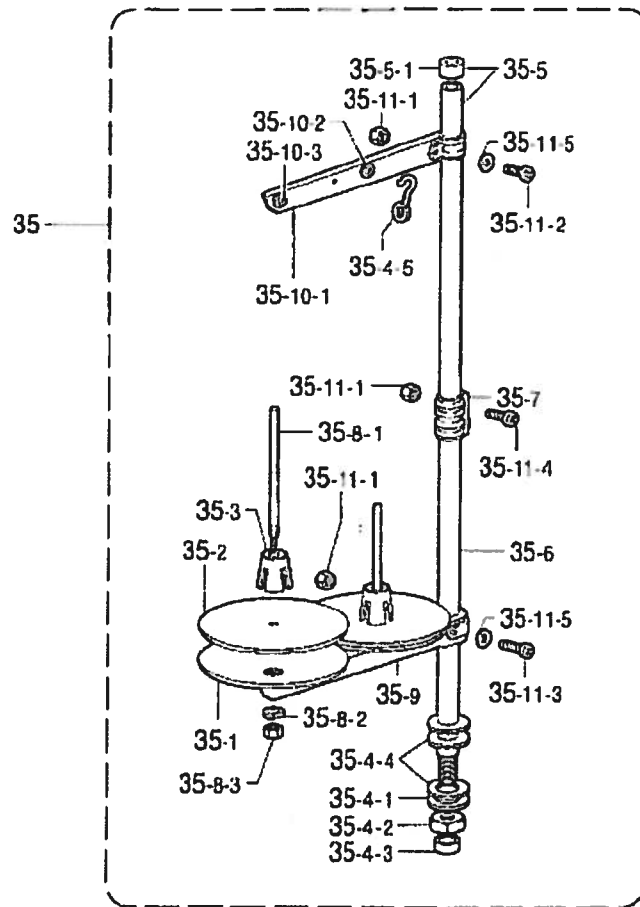
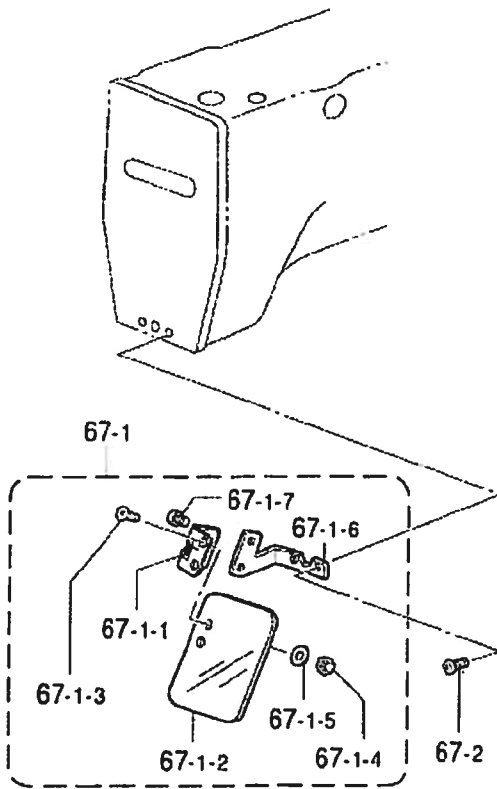

Z2 . 付属品関係 / Accessories

REF.NO	CODE	QTY	ヒンメイ	NAME OF PARTS	RM
35	S02763402	1	1トクテクイクミ2DR	COTTON STAND ASSY, 2DR	
35-1	S51283001	2	ウケサヲ	SPOOL STAND BASE	
35-2	150182000	2	ｽﾌﾞ-ﾏｯｼﾞ	SPOOL MAT	
35-3	S51282001	2	ｽﾌﾞ-ﾏｯｼﾞｼﾞﾝ	SPOOL CUSHION	
35-4	S02777001	1	ﾊﾞｲﾌﾞDｼﾞﾝｼﾞｯﾄB	PIPE D SCREW SET, B	
35-4-1	150206002	1	ﾋﾗｼﾞｶﾞｼ16	WASHER, PLAIN 16	
35-4-2	S38648001	1	6ｶｸｼﾞｯﾄU5/8	NUT, U5/8-28	
35-4-3	150174000	1	ｺﾗﾑｷﾞｯﾌﾟ	COLUMN CAP	
35-4-4	S01005000	2	ｲﾄｸﾞｺﾞ	RUBBER WASHER	
35-4-5	S02747101	1	ｲﾄｶﾞﾊﾞ	SPRING	
35-5	S40640001	1	ｺﾗﾑﾊﾞｲﾌﾞｷﾞｯﾌﾟ	COLUMN PIPE W/CAP	
35-5-1	150174000	1	ｺﾗﾑｷﾞｯﾌﾟ	COLUMN CAP	
35-6	156112003	1	ｺﾗﾑﾊﾞｲﾌﾞD	COLUMN PIPE, D	
35-7	150173003	1	ｺﾗﾑｼﾞｮｲﾝﾄ	COLUMN JOINT	
35-8	S21798001	2	ｽﾌﾞ-ﾏｼﾞﾝｼﾞｯﾄ	SPOOL & SCREW SET	
35-8-1	150179002	2	ｽﾌﾞ-ﾏｼﾞﾝ	SPOOL SHAFT, B	
35-8-2	028050246	2	ﾊﾞｼﾞｶﾞｼ2-5	WASHER, SPRING 2-5	
35-8-3	021500106	2	ｼﾞｯﾄ5	NUT, 1 M5	
35-9	S02778002	1	ｽﾌﾞ-ﾏｼﾞﾝ-2	SPOOL HOLDER, 2	
35-10	S02786002	1	ｽﾚｯﾄﾞﾊﾝｶﾞ-ｸﾐ2	SPOOL HOLDER, 3	
35-10-1	S02787002	1	ｽﾚｯﾄﾞﾊﾝｶﾞ-2	SPOOL HOLDER, 4	
35-10-2	150183000	2	ｲﾄｶﾞﾊﾝｶﾞ-ﾀﾞｲ	THREAD HANGER BASE	
35-10-3	142990001	2	ｽﾚｯﾄﾞﾌﾞｼﾞ	THREAD BUSH	
35-11	S40641001	1	ｽﾌﾞ-ﾏｼﾞﾝｼﾞｯﾄA	SPOOL SHAFT & SCREW SET, A	
35-11-1	021500106	4	ｼﾞｯﾄ5	NUT, 1 M5	
35-11-2	062501406	1	ﾈｯﾄ5X14	SCREW, PAN M5X14	
35-11-3	S59931001	1	ﾈｯﾄM5X32	SCREW, PAN M5X32	
35-11-4	062501406	2	ﾈｯﾄ5X14	SCREW, PAN M5X14	
35-11-5	025050136	2	ﾋﾗｼﾞｶﾞｼ5	WASHER, PLAIN S 5	
67	S49602201	1	ｱｲｶﾞｰﾄﾞｼﾞｯﾄC	EYE GUARD SET, C	
67-1	S44493101	1	ｱｲｶﾞｰﾄﾞ	EYE GUARD ASSY	
67-1-1	S44483001	1	ｼﾞﾝｼﾞﾝ	HINGE ASSY	
67-1-2	S44485001	1	ｱｲｶﾞｰﾄﾞ	EYE GUARD	
67-1-3	061660806	2	ﾌﾗｯﾄ318-40X8	SCREW, FLAT SM3.18-40X8	
67-1-4	021660102	2	ｼﾞｯﾄ3.18	NUT, 1 SM3.18	
67-1-5	025030232	2	ﾋﾗｼﾞｶﾞｼ3	WASHER, PLAIN M 3	
67-1-6	S44486101	1	ｱｲｶﾞｰﾄﾞ-ﾀﾞｲ	EYE GUARD HOLDER, A	
67-1-7	062670512	2	ﾈｯﾄ357-40X5	SCREW, PAN SM3.57-40X5	
67-2	062671016	2	ﾈｯﾄ357-40X10	SCREW, PAN SM3.57-40X10	

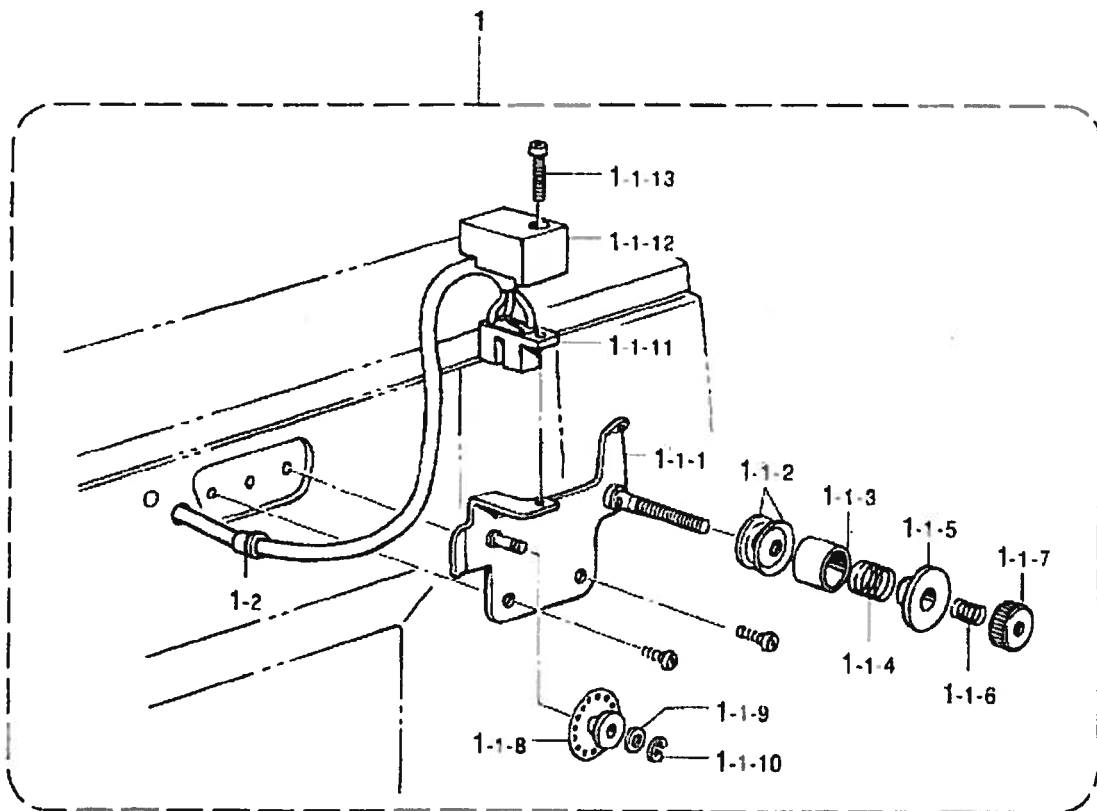

AA1. 付属アタッチメントセット / Attachment set

REF.NO	CODE	QTY	ヒンメイ	NAME OF PARTS	RM
			"糸切れ感知装置"	"Thread breakage detector"	
			<フーリー式>	<Rotary-type>	
1	S43833109	1	トキレカンソウセットR	TR. BREAKAGE DETECTOR SET, R	
1-1	S43834109	1	ロータリートキレカンソウ	TR. BREAKAGE DETECTOR ASSY, R	
1-1-1	S18032001	1	トキレカンソウブラケット	DETECTOR BRACKET ASSY	
1-1-2	144504001	2	トクアナイテラ	THREAD GUIDE DISC	
1-1-3	146206009	1	トクアナイテラオヤ	DISC PRESSER, T-GUIDE	
1-1-4	146058001	1	プレテンションバネ	PRE-TENSION SPRING	
1-1-5	146059001	1	プレテンションナット	PRE-TENSION NUT	
1-1-6	146060000	1	ナットバネ	SPRING	
1-1-7	155510001	1	トクアナイテラ	TENSION NUT	
1-1-8	157255100	1	フーリーA	PULLEY, A	
1-1-9	025030135	1	ヒラシガネ	WASHER, PLAIN S 3	
1-1-10	048020342	1	トメ	RETAINING RING, E2	
1-1-11	S43835100	1	トキレカノセンサ	SENSOR ASSY	
1-1-12	S18037009	1	センサカバー	SENSOR COVER	
1-1-13	062301616	1	ネジ	SCREW, PAN M3X16	
1-2	146080000	1	コードブッシュ	CORD BUSH	











p. 仕様別部品一覧表 / DIFFERENT PARTS LIST



F-434C, 435C には下記部品が用意されていますので幅広い用途にご活用ください。



The following are standard gauge parts according to each specification.

表中★の部品は、KE-430C電子円止めミシンと共通です。☆の部品は、BAS-311Fプログラム式電子ミシンと共通です。

In the following table, parts marked with ★ are common with the LK3-B430E; parts with ☆ are common with the BAS-311F.

仕様 Spec.	シートベルト用 For seat belt	
品名 Part name		
K-100) 針穴板 Needle hole plate 	(φ3.0) S40217-001 3ザグリ	★
F-18) ボビンケース組 Bobbin case assy 	S00691-401 B	
(F-28) ボビン調子ばね Spring 	S00711-101 B	
(F-29, 30) ボビンケースばねねじ Screw 	181937-001 181938-001	
(F-19) 空転防止ばね Anti-spin spring 	S01767-001	
F-20) ボビン Bobbin 	S00871-101 B	★
F-17) かま箱組 Rotary hook assy, w/box 	SA2036-101	
H-14) 糸調子ばね Spring, tension 	S06548-001	★
H-10) 糸取りばね Thread take-up spring 	144588-001	★
H-21) 副糸調子ばね Spring, tension 	107606-001	★

仕様 Spec.	シートベルト用 For seat belt	
品名 Part name		
(H-25) 針棒糸案内 Thread guide, n-bar 	S02439-001 B	★
(Z-17-1) ミシン針組 Needle assy 	DP×17 #25 SA1645-025	☆
(B-26) 針 Needle 	DP×17 #25 145646-025	☆

仕様 Spec.	ブランク中厚物用 Blank for Medium -weight materials	ブランク厚物用 Blank for Heavy -weight materials
品名 Part name		
押えブランク Work clamp blank 	434-1R S42030-001	434-2R S42032-001
	434-1L S42031-001	434-2L S42033-001
送り板ブランク Feed plate blank 	434-1 S42034-001	434-2 S42035-001

Ga . ゲージ部品一覧表 / Gauge parts LIST

<ゲージ部品>

オプションのゲージ部品には次のものがあります。押えと送り板は、上下の組合わせになります。

- ・ 押えと送り板



< Gauge parts >

The following are provided as optional gauge parts.

Each work clamp pair are used in combination with the feed plate directly below them.

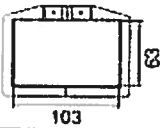
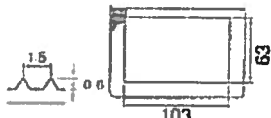

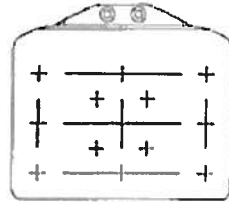

- ・ Work clamps and feed plate

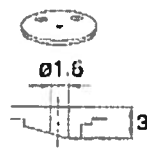
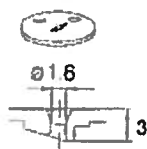
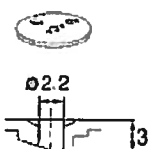
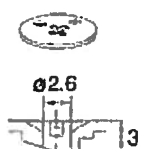
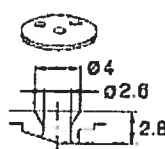
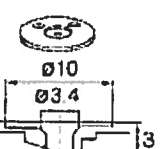
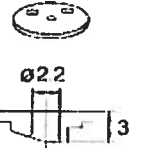
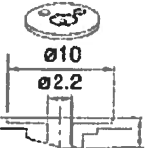
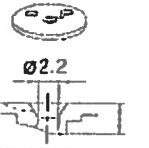
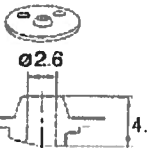
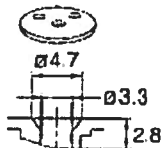
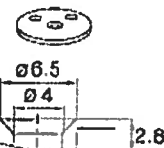
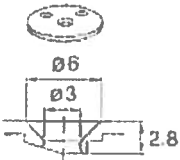
	1
R	153493-001
L	153498-001
押え Work clamp	
送り板 Feed plate	153503-001 

(C2-905) ゲージ組 434E MK2 / Gauge assy, 434E MK2	
S54984-001	
原点基準板 (C2-905-1) / Home position standard plate S52100-001	送り板締めねじ / Screw (C2-905-2) S49955-001
	

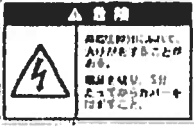
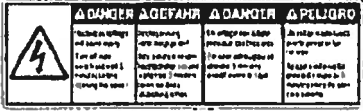
(K-100) 針穴板 / Needle hole plate											
A	S10211-001	AF	S51449-001	BZ	S41013-001	D	S29997-001	E	S10212-101	ED	S30925-001
									 (厚物用標準 / For Heavy -weight materials)		
F	S10213-001	FD	S30926-001	FM	S49980-001	H	S30450-001	L	S25127-001	M	S34348-001
					 (中厚物用標準 / For Medium -weight materials)						
3	S40217-001										
											

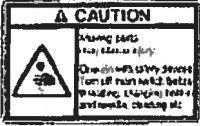
Wa. 警告ラベル / Warning labels

警告ラベル / Warning labels	品名 / Name of parts	Size(mm)	Code
	電撃ラベル・和	40×64	S38353-101
	Label, elec. shock 4 lang.	45×118	S38352-101
	操作注意ラベル・和	40×64	S38350-001
	Label, operation Eng.	40×64	S38349-001
	PE マーク Label, PE	7.5×12.5	S37059-001
	アースマーク Label, grounding	φ 12	S37060-001

CODE	REF.NO	Page	CODE	REF.NO	Page	CODE	REF.NO	Page	CODE	REF.NO	Page
002300403	1-2-11	52	021400102	81	56	048050342	1-10	24	070688850	16	10
004400603	1-1-5	50	021400106	52	42	048050346	1-1-14	50		22	10
004400603	1-2-3	52		40-10	46		1-2-15	52	071047650	5	10
008400604	1-22	36	021400206	1-6	36	048060342	32	26	072630260	8	4
011679312	410	2	021500106	21	44	048070342	19	26	076900800	3	18
014680622	91-6-2	14		35-11-1	58	048100142	1-4	24	081007070	65	6
	1-9	24		35-8-3	58	048150142	10	4	087310815	1-1-5	48
	42	26	021660102	67-1-4	58	048180142	9	10	087311015	1-1-9	48
014680632	8-2	26	021670202	5	30	048200142	9	18	091170009	1-5	34
014710522	2	30	021680202	1-24	24	048350242	52	4	093650008	1-3	34
014760622	1-7	10		92	56	052400606	1-1-15	50	093650032	1-4	34
	6	10	021750302	19	30		1-2-16	52	0A4301005	1-13	34
	7-4	10	025030135	1-1-9	60	060670412	6	30		1-26-18	36
	11	10	025030232	30-1-8	44	060670512	16	20	0A4400605	42	42
	14	10		67-1-5	58	060670612	4	22	0A4400805	1-1-6	48
	20	10	025030236	1-2-13	52		6	22	0A5400806	1-9	36
	26	10	025040232	35	10	060670812	19	2		17	46
	29	10		91-10	14	060680712	32	10	0A5401006	11	46
	44-11	12	025040236	14	30	060681212	20	16		41	46
	91-9	14		51	42		5	26		43	46
	25	16		1-1-16	50	061660806	67-1-3	58		5	46
	10	18		1-12	50	062020806	40-4	46	0A5401206	1-10	36
	12	18	025050236	1-9	50	062300612	43	30		1-5	36
	33	26	025060232	46	8	062300806	8	46	0A5401606	50	42
	10	54		48	14		1-2	48	0A5403006	1-8	36
014760632	28	22		406	56	062301205	1-1-8	50	0A5501205	20	44
014770622	3	4	025060236	5	42		1-2-6	52	100022004	1-26	24
	14	4	025060336	57	54	062301616	1-1-13	60	100022005	25	26
	16	18	025080232	55	4	062302506	30-1-6	44		26-3	26
	33	18		39	8		1-1-21	50		76	28
	2	26	025080236	1-6	50	062400616	40-6	46	100032004	43	10
	23	26	025680132	7	34	062400806	2	34		51	26
014780622	6	4	025680232	54	12	062401006	76	56	100136001	20	22
	17	4		1-27	24	062401216	40-7	46		1-20	24
017680512	16	2		4	24	062501406	35-11-2	58	100242003	20	4
	49	8		94	56		35-11-4	58	100250001	13	4
018061436	56	28	025900232	59	4	062670412	31	22	100360003	101	28
	66	28	026040236	40-8	46	062670512	28	20	100402004	17	22
	4	42	026050136	35-11-5	58		39	20		1-7	24
018062022	41	8	028030242	30-1-7	44		52	20	100645003	103	28
	22	30	028030246	1-2-12	52		13	46		35	30
018062522	42	8	028040246	30-5	8		67-1-7	58	100887001	30	54
018063022	44	8		13	30	062670612	55	12	101572101	28	54
018082536	1-4	50		15	32		24	22	101706001	3-2	10
018083022	37	8		1-11	50	062671016	67-2	58	102571003	104	28
018084032	54	4	028050246	1-8	50	062680512	1-18	24	102630001	18	4
018400622	91-11	14		35-8-2	58	062680612	38	10	104449001	11	2
	31	20	028060242	45	8		38	18	104450101	4	2
018400632	34	10	028060246	7	42		3	24		10	2
018400836	12	30	028080242	56	4	062680812	16-8	4		501	16
018401236	30-4	8		38	8		16-8	4		400	56
	1-10	50	028080246	1-5	50		408	56	104521002	32	18
018401636	9	32	028680242	22-6	26	062681012	26	2	104567101	22	20
018402522	3-2	46	032422003	22	44		24	10	104821001	30	2
018405032	80	56		71	54	062681212	2	24	105812003	63	6
018501022	50	14	032422505	61	54	062681412	6	34		15	26
018501036	1-7	50	032461606	58	54	062710612	2	22	106629002	15	2
021060102	43	8	037301215	4-3	54	062710812	710	2		403	56
	63	28	048020342	1-1-10	60		2	32	107038003	91-15	14
021060106	6	42	048040342	91-20	14	062711012	42	2	107149001	5	20
	56	54	048050342	91-8	14	062761012	405	56	107321003	11	32

索引 / INDEX

CODE	REF.NO	Page	CODE	REF.NO	Page	CODE	REF.NO	Page	CODE	REF.NO	Page
107606001	21	22	145646025	26	4	153391001	47-1	12	J02657001	2-2-3	40
107779001	29	54	145751001	39	18	153393001	4	10		2-3-3	40
107780001	31	54	146058001	1-1-4	60	153403002	904	14		2-4-3	40
108802001	1-4	10	146059001	1-1-5	60	153596001	20	26		2-7-3	40
109239002	24	2	146060000	1-1-6	60	153924001	1-3	10	J80868001	1	48
109714000	5	54	146080000	1-2	60		45	20	S00554000	1-17	36
	12	54	146206009	1-1-3	60	154467001	4-2	54	S00691401	18	18
	21	54	147777000	16-9	4	154514001	40-9	46	S00705001	47	26
110168001	91-22	14		16-9	4	154528001	1-12	24	S00711101	28	18
110233001	71	28	148133001	44-4	10	154596000	21	26	S00831101	28	18
110367001	31	26	148738000	4	20	154599000	6	26	S00871101	20	18
111140002	50	26		40	20	155055001	3-1	46		16	54
113006001	55	20		41	20	155167002	17	30	S01005000	35-4-4	58
114294001	9	22	148847001	13	26	155510001	1-1-7	60	S01767001	19	18
114483002	22	54		23	44	155578000	21	4	S02354001	24	26
114486002	6	54	148851001	1-21	24	156076101	44-1	10	S02439001	25	22
115186001	19	22	149173001	25	54	156077001	44-7	12	S02460001	13	18
116920001	9	4	149482001	23	30	156080000	44-8	12	S02652001	7	26
116922001	12	22	149796001	10	44	156108001	44-5	10	S02654001	8-1	26
117934001	6	2	149809000	45	42	156109001	44-6	12	S02747101	35-4-5	58
	18-3	2		48	42	156112003	35-6	58	S02763402	35	58
117936001	1-1-17	50	150173003	35-7	58	157255100	1-1-8	60	S02777001	35-4	58
	1-2-17	52	150174000	35-4-3	58	157968001	1-17	24	S02778002	35-9	58
118064001	34	54		35-5-1	58	158907001	50	4	S02786002	35-10	58
118837001	27	54	150179002	35-8-1	58	158909001	58	4	S02787002	35-10-1	58
120448001	1-13	24	150182000	35-2	58	159574101	1-19	24	S03800001	91-19	14
120990001	1-14	24	150183000	35-10-2	58	159805001	15	22	S04897000	12	44
122991001	14	54	150206002	35-4-1	58	159905001	62	6	S05822001	22	18
123006001	15	4	150551000	11	22		14	26	S06548001	14	22
	65	28	150592001	29	2	159906001	61	6	S06706001	15	54
133740006	55	54	152233101	16-1	4	181937001	29	18	S07220001	23	18
139096001	91-6-1	14	152242001	24	4	181938001	30	18	S07221001	23	18
140392009	5	2	152243001	25	4	183493001	3	10	S07222001	25	18
	7	2	152756001	10	10	200190001	42	54	S07333001	2	20
	401	56	152760051	8	10		62	54	S07456000	3	20
140518001	64	6	152827001	1	30	218859001	2-1-5	40	S08030000	1-26-16	36
140647101	40-5	46	152842059	22	2		2-2-5	40		101	56
140726000	7	4	152872001	8	22		2-3-5	40	S08178000	11	44
141400009	62	28	152881001	27	22		2-4-5	40	S09043000	32	20
141492001	26-2	26	152883000	29	22		2-7-5	40	S09197000	69	28
141590001	1-25	24	152884001	30	22		25	46	S09212001	3-1	10
142443001	26	54	152889001	23	22	224514001	2-1-4	40	S09228000	30-1-4	44
142721001	33	54	152891101	26	22		2-2-4	40	S09318101	30-1-2	44
142990001	35-10-3	58	152948001	33	20		2-3-4	40	S10058001	91-5	14
143591001	91-7	14	152956001	42	20		2-4-4	40	S10091201	407	56
143882001	9	54	152969001	38	20		2-7-4	40	S10125000	500	16
144105000	1-23	24	152973001	7-5	10	228475000	44	20	S10162201	15	20
144226001	51	54	153057101	36	18		102	28	S10174000	1-15	24
144458001	23	4	153112001	4	30		12	36	S10195101	30	26
144504001	1-1-2	60		16	30		13	44	S10202201	24	16
144588001	10	22	153242000	1-26-15	36		22	46		41	26
145318001	42	10		102	56		1-1-9	50	S10208001	46	26
	62	12	153369001	91-13	14		1-2-7	52		18	54
145446001	16	22	153370001	91-14	14	231071001	17	26	S10208002	46	26
	22	22	153377001	44-2	10	232384001	1-26-7	36		18	54
	1-22	24		900	14	552907000	4	46	S10208003	46	26
145465001	16-5	4	153378001	44-3	10		10	46		18	54
	16-5	4		901	14		42	46	S10208004	46	26
145478101	10	26	153380001	44-9	12	600961000	4	18	S10209101	48	26
145480101	23	2	153383001	45	12	625010000	12	46	S10377101	91-3	14
145547001	27	20	153384001	46	12	J02657001	2-1-3	40	S10378101	91-4	14

CODE	REF.NO	Page	CODE	REF.NO	Page	CODE	REF.NO	Page	CODE	REF.NO	Page
S10468001	18	22	S37942100	27	10	S38178101	1-2	50	S43688001	3	44
S10892001	64	28	S37944000	28	10	S38179101	1-3	50	S43688002	4	44
S11244001	52	26	S37985000	24	20	S38180000	1-1-18	50	S43833109	1	60
S11426000	26-2	16	S37986000	25	20		1-2-18	52	S43834109	1-1	60
S11949000	1-16	36	S37992100	1-2	24	S38203000	1-26-5	38	S43835100	1-1-11	60
S12150000	3-3	32	S37993000	1-3	24	S38205000	1-26-9	36	S43843009	42	30
S12404000	30-1-5-2-1	44	S37994001	1-5	24	S38208000	1-26-14	36	S43907309	707	2
S12441001	33	22	S37996001	1-8	24	S38349001	75-2	56	S44010001	31	2
S12685001	903-2	14	S37998001	1-16	24	S38350001	75-2	56	S44483001	67-1-1	58
S12696001	77	28	S38002201	3	26	S38352101	20	36	S44485001	67-1-2	58
S15097000	26-1	16	S38003101	9	26	S38353101	21	36	S44486101	67-1-6	58
S15609001	26	18	S38004002	11	26	S38648001	35-4-2	58	S44493101	67-1	58
S15610001	27	18	S38004003	11	26	S38744101	40-2	46	S44629001	920	2
S18032001	1-1-1	60	S38004004	11	26	S39110001	49	14	S44805101	1-2	52
S18037009	1-1-12	60	S38005001	16	26	S40616001	40-1	42	S44806000	1-2-5	52
S18093100	26	20	S38039209	4	54	S40620000	41	42	S44807000	1-2-5-1	52
	4-4	54	S38040209	4-1	54	S40621000	43	42	S46694000	1-1-20	50
S18387006	13	32	S38044001	59	54		46	42	S46703000	1-1-7-2	48
	14	32	S38045109	19	54	S40622000	44	42	S47089001	16-1	4
	7	44	S38059000	1-2-20	52		47	42	S47091001	16-3	4
	8	44	S38060000	1-1-19	50	S40623000	49	42		16-3	4
	9	44		1-2-19	52	S40628000	30-1-3	44	S47335101	5	24
S18415101	91-18	14	S38080001	4	34	S40629000	30-1-9	44	S47592000	2-4	40
	44	30	S38082001	5	34	S40635001	40	42	S47594000	2-7	40
	30-1-5-1-3	44	S38093000	1-4	36	S40640001	35-5	58	S47595000	2-4-2	40
S20164001	28	2	S38107100	1-12	36	S40641001	35-11	58		2-7-2	40
S20878000	12	32	S38108000	1-13	36	S41060109	709	2	S47692000	1-7	36
S21775001	91-6	14	S38109100	1-14	36	S41222101	64	54	S48578000	1-14	34
S21798001	35-8	58	S38110000	1-15	36	S41271000	91-23	14	S48579000	1-1-7-3	48
S21881001	26	30	S38112001	2-1	40	S41290301	708	2	S48580000	1-26-17	36
S23337001	17	2	S38113000	2-1-1	40	S41658000	91-1	14		103	56
S23618001	66	6		2-4-1	40	S41660001	91-12	14	S48587000	1	46
S23660000	3-2	32	S38114000	2-2	40	S41703000	12	10	S48589000	2	46
S23836001	8	26	S38115000	2-2-1	40	S41705001	15	10	S48666001	1	34
S23880000	30-1-10	44		2-3-1	40	S42067101	1-1	10	S49071000	1-26-8	36
S24511007	26	4		2-7-1	40	S42069001	7	10	S49443000	3	52
	17-2	54	S38116000	1-23	36	S42070001	7-1	10	S49465008	21	46
S24523000	26	16	S38117000	2-3	40	S42083001	41	10	S49467001	1	36
S29019000	1-1	34	S38118000	2-2-2	40	S42084101	44	10	S49468001	1-1	36
S29023000	1-1-7-1	48	S38120000	2-5	40	S42086001	44-10	12	S49469001	1-2	36
S30280000	1-1-7-5	48	S38123000	3-1	40	S42260000	1-11	36	S49470001	1-3	36
S31032001	13	22	S38126000	3-2-2	40	S42867001	1-2-2	52	S49471000	1-8	34
S31760000	1-18	36		3-3-2	42	S43175000	1-26-11	36	S49472000	1-26-21	36
S32235001	18	26	S38133000	2-1-2	40	S43176000	1-26-12	36	S49473000	3-2	40
S32259001	8	32		2-3-2	40	S43177000	1-26-1	36	S49474000	3-2-1	40
S33006001	52	54	S38143000	11-1	36	S43178000	1-2	34	S49475000	3-3	42
S35001000	56	20	S38144100	14-1	46	S43181000	1-26-13	36	S49476000	3-3-1	42
S35766001	51	4	S38146000	14-2	46	S43184000	1-26-2	36	S49477000	10	36
S36260000	1-1-7-2	50	S38147000	14-3	46	S43187000	1-26-20	36	S49479001	1	34
	1-2-5-2	52	S38148000	16	46	S43188000	2-6	40	S49484000	1-6	34
S37059001	1-24	36	S38155000	1-9	34	S43189000	1-26-19	36	S49485000	1-7	34
S37060001	1-25	36	S38166000	1-2-1	52	S43201000	3-4	42	S49486000	1-11	34
S37915009	12	2	S38168001	1-1-3	50	S43275000	1-19	36	S49495000	1-1-3	48
S37926101	16-7	4	S38169201	1-1-4	50	S43276000	1-20	36	S49496001	1-1-4	48
	16-7	4	S38170001	1-1-6	50	S43277000	1-21	36	S49497001	1-1-7	48
S37932101	1-5	10		1-2-4	52	S43683001	30-1-5-1-2	44	S49510000	1-1-8	48
	7-2	10	S38174000	1-2-8	52	S43686000	30-1-11	44	S49582001	4	4
S37933001	1-6	10	S38175001	1-2-9	52	S43687001	67	28	S49583001	5	4
	7-3	10	S38176101	1-2-10	52		1	44	S49586000	1-26-3	36
S37934101	2	10	S38177001	1-1-13	50	S43687002	68	28	S49593000	19	4
S37940001	23	10		1-2-14	52		2	44	S49602201	67	58

索引 / INDEX

CODE	REF.NO	Page	CODE	REF.NO	Page	CODE	REF.NO	Page	CODE	REF.NO	Page
S49603000	11	54	S51859101	5	22	S56531001	1	32	S59873001	22-4	26
S49604000	20	54	S51860001	47-2	12	S56532001	4	32	S59874001	22-1	26
S49618000	53	20	S52091000	1-1-2	48	S56533101	10	32	S59892001	53	12
S49620000	17	20	S52100001	905-1	14	S56864001	20	30		93	56
S49622000	19	20	S52744000	45-1	46	S57632001	1	4	S59893001	12	26
S49627001	3	22	S52836000	47	8	S57633001	12	4		33	30
S49641001	19	16	S52838000	35	8	S57634001	16	4		91	56
S49646101	22	26	S52839200	36	8	S57635001	1-6	24	S59920001	41	2
S49648001	26	26	S53031001	H-1	38	S57636001	16-2	4	S59931001	35-11-3	58
S49649001	26-1	26	S53032000	11	36	S57637001	16-4	4	S60400000	351	56
S49669100	1-1-1	50	S53033001	H-2	38		16-4	4	S60711001	352	56
S49672001	1-1-2	50	S53034001	H-3	38	S57638001	16	4	SA0037000	1-26-6	36
S49673000	1-1-11	50	S53035001	H-4	38	S57642001	53	4	SA0049001	22-5	26
S49674001	1-1-12	50	S53036001	H-5	38	S57644001	2	4	SA0216001	29	20
S49689001	16-6	4	S53037001	H-6	38	S57645001	60	4	SA0217001	30	20
	16-6	4	S53038001	H-7	38	S57646001	1	18	SA0218001	75	28
S49938000	1-26-22	36	S53039001	H-8	38	S57647001	2	18	SA0219001	72	28
S49939101	1-26	36	S53040001	H-9	38	S57648001	30	8	SA0771001	31	30
S49955001	905-2	14	S53055100	2	48	S57649001	30-1	8	SA1034000	1-26-10	36
S49957000	18	20	S53091001	91	14	S57650001	5	18	SA1054001	60	12
S49958000	47	20	S53092001	91-2	14	S57651001	6	18	SA1055001	61	12
S49959001	14	20	S53094001	91-16	14	S57652001	7	18	SA1087001	68	6
S49962000	18-2	2	S53095000	91-17	14	S57653001	8	18	SA1587001	1-1	24
S49983000	20	20	S53096001	91-21	14	S57654001	11	18	SA1645025	17-1	54
S49984000	21	20	S53097001	1	22	S57655001	15	18	SA2036101	17	18
S49985000	48	20	S53099001	13	10	S57657001	37	18	SA2039001	40	18
S49986000	49	20	S53100001	19	10	S57661001	1-11	24	SA2051001	22	4
S49987000	50	20	S53108001	33	10	S57662001	1	26	SA2205001	35	18
S49992000	1	20	S53109001	36	10	S57663001	43	26	SA2210001	310	12
S49994001	38	26	S53117101	409	2	S57664001	29	26	U32744000	1-12	34
S49995001	51	20	S53119001	13	2	S57665001	27	26	U34870001	1-1-7-4	48
S50048000	3-1	32	S53120001	14	2	S57667001	44	26	UA4817000	10-1	36
S50049000	7	32	S53488000	54	28	S57668001	45	26		350-1	56
S50050000	6	32	S54644000	1-1-7-1-1	50	S57670001	49	26	UL0025000	1-1-7-6	48
S50051000	5	32	S54645000	1-1-7-1-2	50	S57672001	25	30	XA2220050	1-1-10	48
S50052000	3	32	S54650000	1-1-7	50	S57673001	53	28	Y51030150	1-15	34
S50645000	1-10	34	S54691000	1-1-7-1	50	S57674001	74	28			
S51097000	75-1	56	S54984001	905	14	S57681001	61	28			
	75-1	56	S55133000	36	30	S57686001	34	26			
S51098000	40	2	S55151000	32	30	S57689001	23	16			
S51099000	17	10	S55199001	22	16	S57695001	30-1-1	44			
S51100001	18	10	S55208000	25	2	S57700001	16-2	4			
S51101001	21	10	S55311001	75	56	S57705001	55	28			
S51102001	903-1	14	S55311002	75	56	S57710001	6	46			
S51103001	25	10	S55473000	1-26-4	36	S57867001	10	30			
S51282001	35-3	58	S55572001	31	8	S57868001	11	30			
S51283001	35-1	58		48	8	S57869001	15	30			
S51451000	1-1-10	50	S55627001	54	36	S57872001	3	30			
S51457109	18	2	S55629101	40	46	S57873001	24	30			
S51458109	18-1	2	S55630001	40-1	46	S57874001	30	30			
S51459001	404	56	S55632001	40-3	46	S57876001	21	30			
S51460009	33	2	S55633001	70	54	S57878001	45	48			
S51461001	402	56	S55663001	23	54	S57879001	30-1	44			
S51462001	30	10	S55889001	1	48	S57880001	30-1-5	44			
S51463001	31	10	S55890001	1-1	48	S57881001	30-1-5-1	44			
S51465001	37	10	S55891000	1-1-1	48	S57882001	30-1-5-1-1	44			
S51844000	350	56	S56018000	30-2	8	S57883001	30-1-5-2	44			
S51846101	1	50	S56019001	30-3	8	S57976001	69-1	8			
S51847101	1-1	50	S56167000	6-1	46	S57978001	70	8			
S51857101	1	10	S56167001	6-2	46	S59871001	22-3	26			
S51858001	1-2	10		6-3	46	S59872001	22-2	26			

brother®

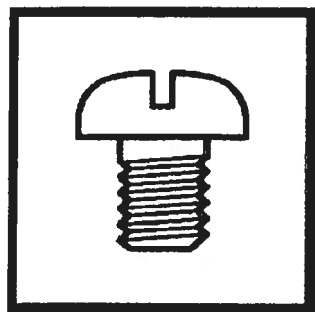

パーツブック
PARTS BOOK

ブラザー工業株式会社

〒467-8561 名古屋市瑞穂区苗代町 15 番 1 号 TEL (052) 824-2392

BROTHER INDUSTRIES, LTD

15-1, Naeshiro-cho, Mizuho-ku, Nagoya 467-8561, Japan. Phone 81-52-824-2177

Printed in Japan

118-B84
SA2033-001
2003.02.H (1)