

brother

LK3-B431

高速本縫筒型バンドループ付ミシン

HIGH SPEED LOCK STITCH BELT LOOP BAR TACKING MACHINE

VERRIEGELUNGSSTICH-SCHNELLNÄHER ZUM ANNÄHEN VON GURTSCHLAUFEN

MACHINE ULTRA-RAPIDE À POINT NOUÉ POUR LA FIXATION DES PASSANTS DE CEINTURE

MÁQUINA DE COSER DOBLE PESPUNTEADORA DE ALTA VELOCIDAD PARA REMATADO DE PASADORES DE CINTURÓN

パーツブック

PARTS BOOK

TEILEKATALOG

LIVRE DES PIÈCES

LIBRO DE REFERENCIA DE PIEZAS



P431201

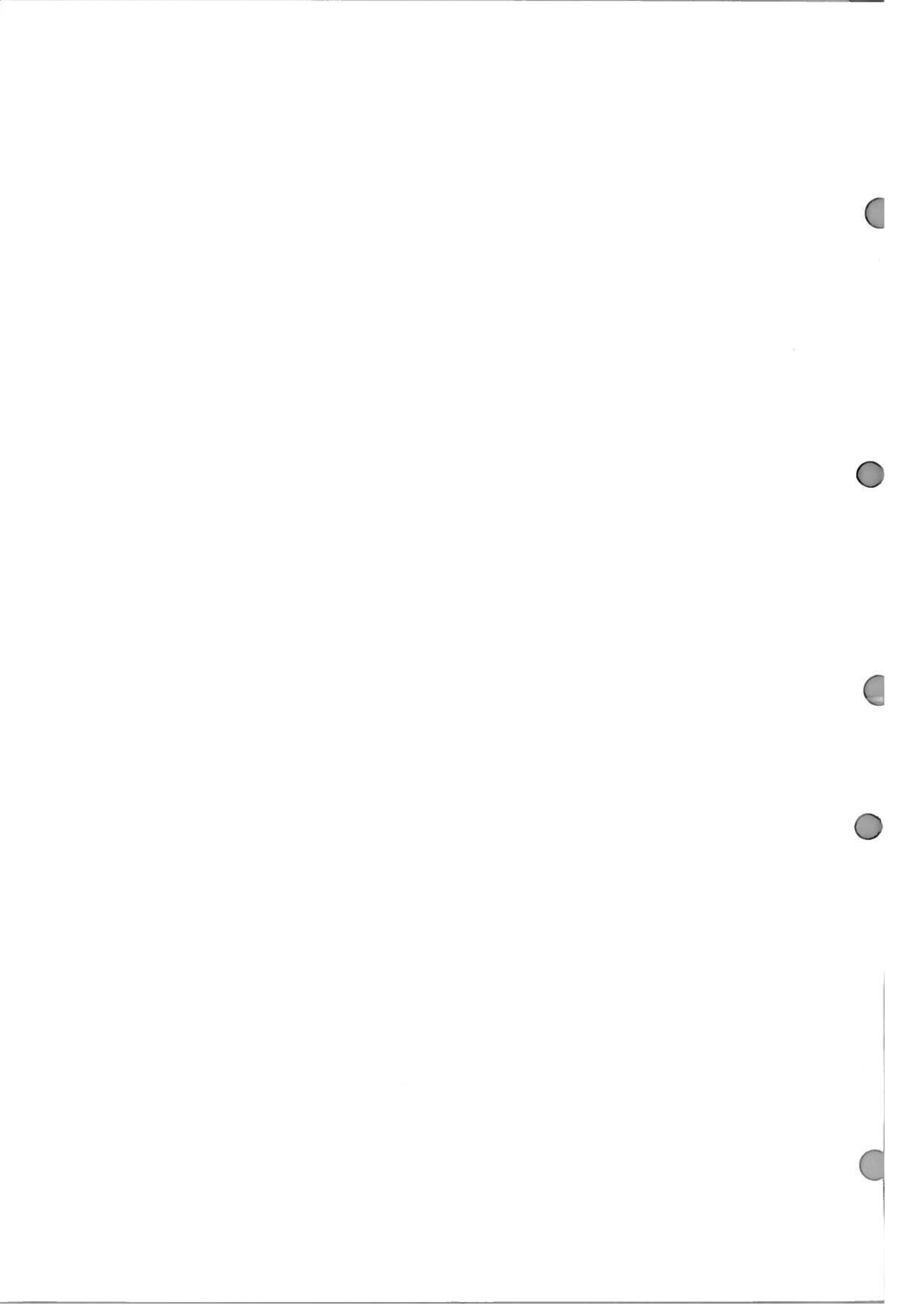

パーツブックご利用に際して

1. この本は、この本の表紙（正誤表の挿入されている場合は正誤表）に記載されているものと同じプレートが取り付けられているミシンのためのものです。
2. 部品コード欄が*となっている場合は、仕様別部品一覧表（41・42ページ）でお調べ下さい。
3. この本は1990年11月のデータに基づいて作成されたものです。
4. 部品は、予告なしに設計変更される場合があります。

目 次

A. 主体関係	2
B. クラッチ関係	6
C. 上軸・針棒関係	10
D. 送り関係	12
E. 押エ上げ関係	16
F. カム伝導関係	18
G. パワー押エ関係	20
H. 下軸関係	22
J. 給油潤滑関係	24
K. 糸通シ関係	28
L. 糸巻キ関係	30
M. 糸切り関係	32
N. 特別注文部品	34
P. 動車・遊車関係	34
Q. 糸払イ関係	36
R. 糸締メ関係	36
Z1. 付属品関係	38
Z2. 付属品関係	40
仕様別部品一覧表	41・42
索引	43

Notes for using this parts book

1. This book is applicable to sewing machines which have the same plate number as shown on the cover of this book (or correction sheet).
2. If the symbol * is found in the "Parts No." column, refer to the different parts list on page 41 · 42.
3. This book was prepared based on information available in November 1990.
4. Parts are subject to changes in design without prior notice.

CONTENTS

A. Machine body	2
B. Clutch mechanism	6
C. Upper shaft and needle bar mechanism	10
D. Feed mechanism	12
E. Work clamp lifter mechanism	16
F. Vertical shaft mechanism	18
G. Power lift mechanism	20
H. Lower shaft mechanism	22
J. Lubrication	24
K. Threading mechanism	28
L. Bobbin winder mechanism	30
M. Thread trimmer mechanism	32
N. Option parts	34
P. Drive pulley and idler pulley mechanism	34
Q. Thread wiper mechanism	36
R. Thread nipper mechanism	36
Z1. Accessories	38
Z2. Accessories	40
DIFFERENT PARTS LIST	41 · 42
INDEX	43

Hinweise zur Verwendung dieser Teileliste

1. Dieses Buch bezieht sich auf die Nähmaschinen mit derselben Kennungsnummer wie auf diesem Buchumschlag (oder auf dem Korrekturblatt).
2. Dieses Zeichen * in der Spalte "Parts No. (Teilnummer)" verweist auf Gesonderte Stückliste auf Seite 41 · 42.
3. Dieses Buch basiert auf den Informationen vom November 1990.
4. Modelländerungen sind vorbehalten.

INHALTSVERZEICHNIS

A. Maschinengehäuse	2
B. Kupplungsvorrichtung	6
C. Obere Welle und Nadelstangenvorrichtung	10
D. Transportvorrichtung	12
E. Stoffhalterhebevorrichtung	16
F. Vertikale Welle	18
G. Heberbetätigungsverrichtung	20
H. Untere Welle	22
J. Schmierung	24
K. Fadenführungsvorrichtung	28
L. Spuler	30
M. Fadenabschneidevorrichtung	32
N. Sonderzubehör	34
P. Antriebsriemenscheibe und Riemenscheibe	34
Q. Fadenwischvorrichtung	36
R. Fadenspannvorrichtung	36
Z1. Zubehör	38
Z2. Zubehör	40
ZUBEHÖRLISTE	41 · 42
VERZEICHNIS	43

Notes sur l'utilisation de ce manuel de pièces détachées

1. Ce manuel est destiné aux machines à coudre ayant le même numéro de plaque montré sur la couverture de ce manuel (ou sur la feuille de corrections).
2. Si le symbole * se trouve dans la colonne "Parts No. (N° de pièce)", veuillez la vous référer à la liste de pièces annexe page 41 · 42.
3. Ce manuel a été fait d'après les renseignements valables au mois de Novembre 1990.
4. Les pièces peuvent être sujettes à des modifications sans préavis.

TABLE DES MATIERES

A.	Corps de la machine	2
B.	Mécanisme de l'embrayage	6
C.	Mécanisme de arbre supérieur et barre à aiguille	10
D.	Mécanisme de l'entraînement	12
E.	Mécanisme de leueur du pinceur	16
F.	Mécanisme d'arbre vertical	18
G.	Mécanisme de leueur	20
H.	Mécanisme de l'arbre inférieur	22
J.	Lubrification	24
K.	Mécanisme de l'enfilage	28
L.	Mécanisme du bobineur	30
M.	Mécanisme de coupe-fil	32
N.	Pièces en option	34
P.	Mécanisme de poulie d'entraînement et poulie folle	34
Q.	Mécanisme de tire-fil	36
R.	Mécanisme de pince-fil	36
Z1.	Accessoires	38
Z2.	Accessoires	40
	LISTE DES PIECES ACCESSOIRES	41 · 42
	INDEX	43

Notas para usar este Manual de Piezas

1. Este libro sirve para todas las máquinas de coser que llevan la misma placa de identificación que la que se puede ver en la tapa de este libro (o en la hoja de erratas).
2. De haber un símbolo * junto al "Parts No. (Número de pieza)", habrá que mirar la lista de piezas separada de la página 41 · 42.
3. Este libro ha sido compilado basándose en los datos de que se disponía en noviembre de 1990.
4. Las piezas quedan sujetas a cambios de diseño sin aviso previo.

INDICE

A. Cuerpo de la máquina	2
B. Mecanismo de embrague	6
C. Mecanismo del eje superior y la barra de aguja	10
D. Mecanismo de la alimentación	12
E. Mecanismo del levantador de ménsula de trabajo	16
F. Mecanismo del eje vertical	18
G. Mecanismo de carreta de potencia	20
H. Mecanismo del eje inferior	22
J. Lubricación	24
K. Mecanismo del enhebrado	28
L. Mecanismo del devanador de la canilla	30
M. Mecanismo de la cortadura de hilos	32
N. Piezas opcionales	34
P. Mecanismo de polea impulsora y polea tensora	34
Q. Mecanismo del limpiador de hilo	36
R. Mecanismo de la mordaza para hilo	36
Z1. Accesorios	38
Z2. Accesorios	40
LISTA DE PIEZAS ACCESORIAS	41 · 42
INDICE	43

A. 主体関係/Machine body/Maschinengehäuse/Corps de la machine/Cuerpo de la máquina

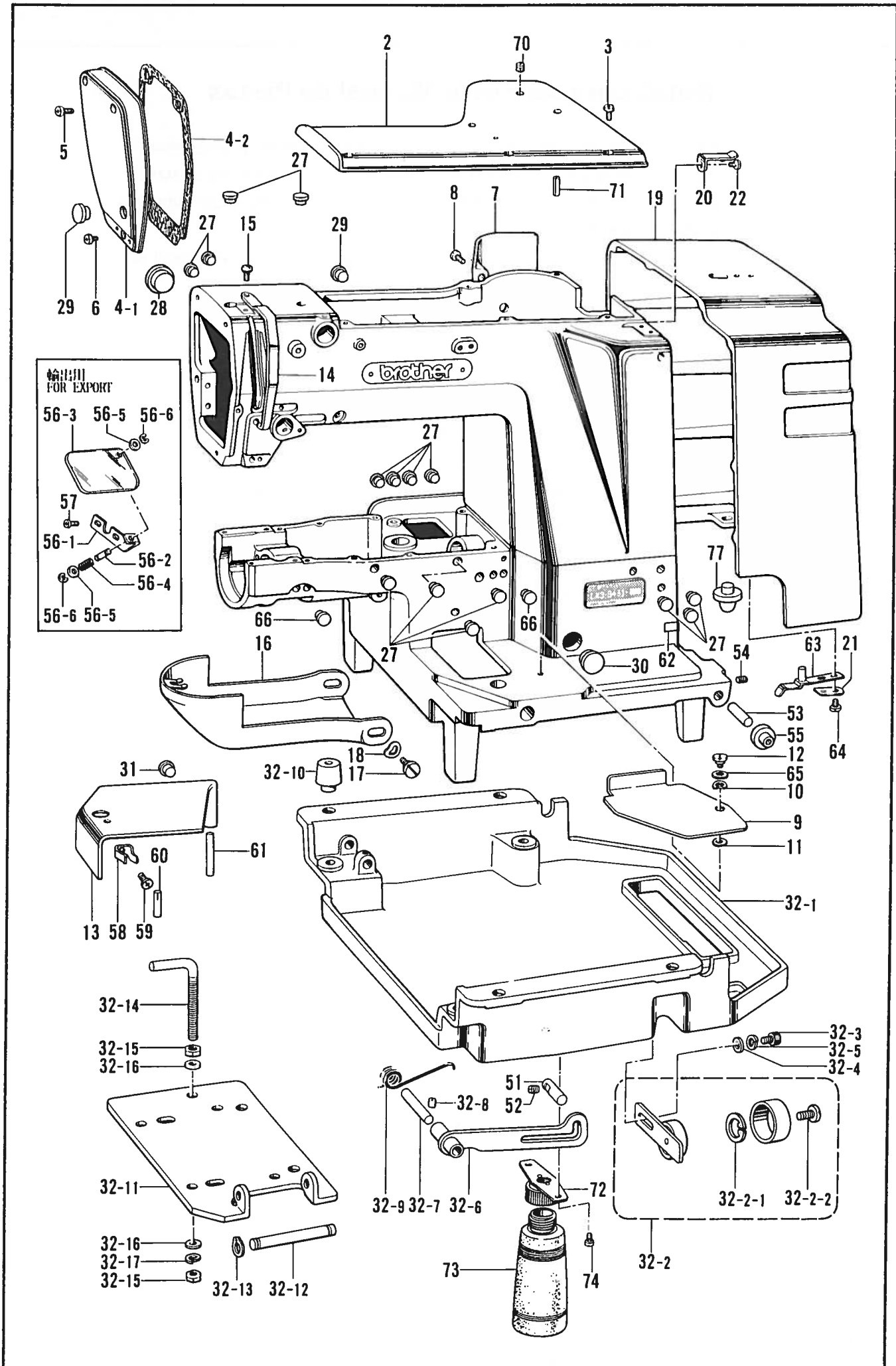

A. 主体関係 / Machine body / Maschinengehäuse / Corps de la machine / Cuerpo de la máquina

REF NO.	CODE	Q'TY	ヒンメイ	NAME OF PARTS	RMKS
2	152830109	1	ウフフタ	TOP COVER	
3	062761412	6	ナヘ"コ595-28X14	SCREW 595X14	
4	152831009	1	メンイタクミ	FACE PLATE ASSEMBLY	
4-1	152832109	1	メンイタ	FACE PLATE	
4-2	152833001	1	メンイタハ"ツキン	PACKING	
5	062711412	2	ナヘ"コ4.76-32X14	SCREW 476X14	
6	062710712	1	ナヘ"コ476-32X7	SCREW 476X7	
7	152834009	1	ソクメンカハ"-	FRAME SIDE COVER	
8	062711412	4	ナヘ"コ4.76-32X14	SCREW 476X14	
9	152835009	1	ハ"ツト"カハ"-R	BED COVER (R)	
10	100315002	1	ナミハ"ネ	WAVE SPRING	
11	025770232	1	ヒラサ"カ"ネチユウ6.35	PLAIN WASHER 6.35	
12	145480001	1	タ"ンネシ"6.35	STUD SCREW 6.35	
13	152836009	1	ハ"ツト"カハ"-Lクミ	BED COVER (L) ASSEMBLY	
14	152841009	1	デンヒ"ンカハ"-	THREAD TAKE-UP COVER	
15	062670812	1	ナヘ"コ357-40X8	SCREW 357X8	
16	152842009	1	オオカマカハ"-クミ	LARGE SHUTTLE HOOK COVER ASSEMBLY	
17	115493002	2	タ"ンネシ"5.95	STUD SCREW 5.95	
18	109239002	2	ナミハ"ネサ"カ"ネ	SPRING WASHER	
20	152989001	1	ハ"ルトカハ"-ハ"ネウケ	BELT COVER SPRING PLATE	
21	152986001	1	ハ"ルトカハ"-ハ"ネササエ	BELT COVER SPRING SUPPORT	
22	062680812	1	ナヘ"コ437-40X8	SCREW 437X8	
27	117936009	15	メクラセン	OIL CAP	
28	140392009	1	オイルフタ	OIL CAP	
29	117934009	2	メクラセン	OIL CAP	
30	108520009	1	メクラセン	OIL CAP	
31	104450109	1	メクラセン	OIL CAP	
32	159808109	1	オイルパンクミ	OIL PAN ASSEMBLY	
32-1	154738109	1	オイルパン	OIL PAN	
32-2	152852101	1	テンションプ"ーリクミ	TENSION PULLEY ASSEMBLY	
32-2-1	048320242	1	トメフア"ナヨウC32	STOP RING C32	
32-2-2	141860001	1	シメネシ"6.35	SCREW 6.35	
32-3	018081222	1	アナホ"ルト8X12	BOLT 8X12	
32-4	025080232	1	ヒラサ"カ"ネチユウ8	PLAIN WASHER 8	
32-5	028080242	1	ハ"ネサ"カ"ネ2-8	SPRING WASHER 2-8	
32-6	152857001	1	トウフ"ササエレハ"-	HEAD SUPPORT LEVER	
32-7	152858001	1	トウフ"ササエレハ"-シ"ク	HEAD SUPPORT LEVER SHAFT	
32-8	013719412	1	トメネシ"4.76クホ"ミ	SET SCREW 4.76	
32-9	152859001	1	トウフ"ササエレハ"-ハ"ネ	HEAD SUPPORT LEVER SPRING	
32-10	152860009	4	ハ"ツト"クツシヨ"ン	BED CUSHION	
32-11	152861101	1	モ"ーター"ダ"イ	MOTOR BASE PLATE	
32-12	152862001	1	モ"ーター"ダ"イシ"ク	MOTOR BASE PLATE SHAFT	
32-13	048100142	2	トメフジ"クヨウC10	STOP RING C10	
32-14	152865101	1	L"カ"タホ"ルトM10	(L) BOLT M10	
32-15	021100202	2	ナツト2シユ10	NUT 10	
32-16	025100132	2	ヒラサ"カ"ネシヨウ10	PLAIN WASHER 10	
32-17	028100242	1	ハ"ネサ"カ"ネ2-10	SPRING WASHER 2-10	
51	152866001	1	トウフ"ササエヒ"ン	HEAD SUPPORT PIN	
52	013760612	1	トメネシ"5.95クホ"ミ	SET SCREW 5.95	
53	152867000	2	ハ"ツト"ヒンジ"シ"ク	HINGE SHAFT	
54	151604002	2	トメネシ"5.95	SET SCREW 5.95	
55	152868009	2	ハ"ツト"ヒンジ"クツシヨ"ン	HINGE CUSHION	
56	*	1	-----	EYE GUARD ASSEMBLY	
56-1	154407001	1	-----	EYE GUARD SUPPORT PLATE	
56-2	154408001	1	-----	EYE GUARD SUPPORT PIN	
56-3	154774001	1	-----	EYE GUARD	
56-4	154767001	1	-----	SPRING	
56-5	105161004	2	-----	WASHER	
56-6	048025342	2	-----	STOP RING E2.5	
57	*	2	-----	SCREW 357X5	
58	114985001	1	ハ"ツトカハ"-トメハ"ネ	BED COVER SET SPRING	
59	062680612	1	ナヘ"コ4.37-40X6	SCREW 437X6	

A. 主体関係 / Machine body / Maschinengehäuse / Corps de la machine / Cuerpo de la máquina

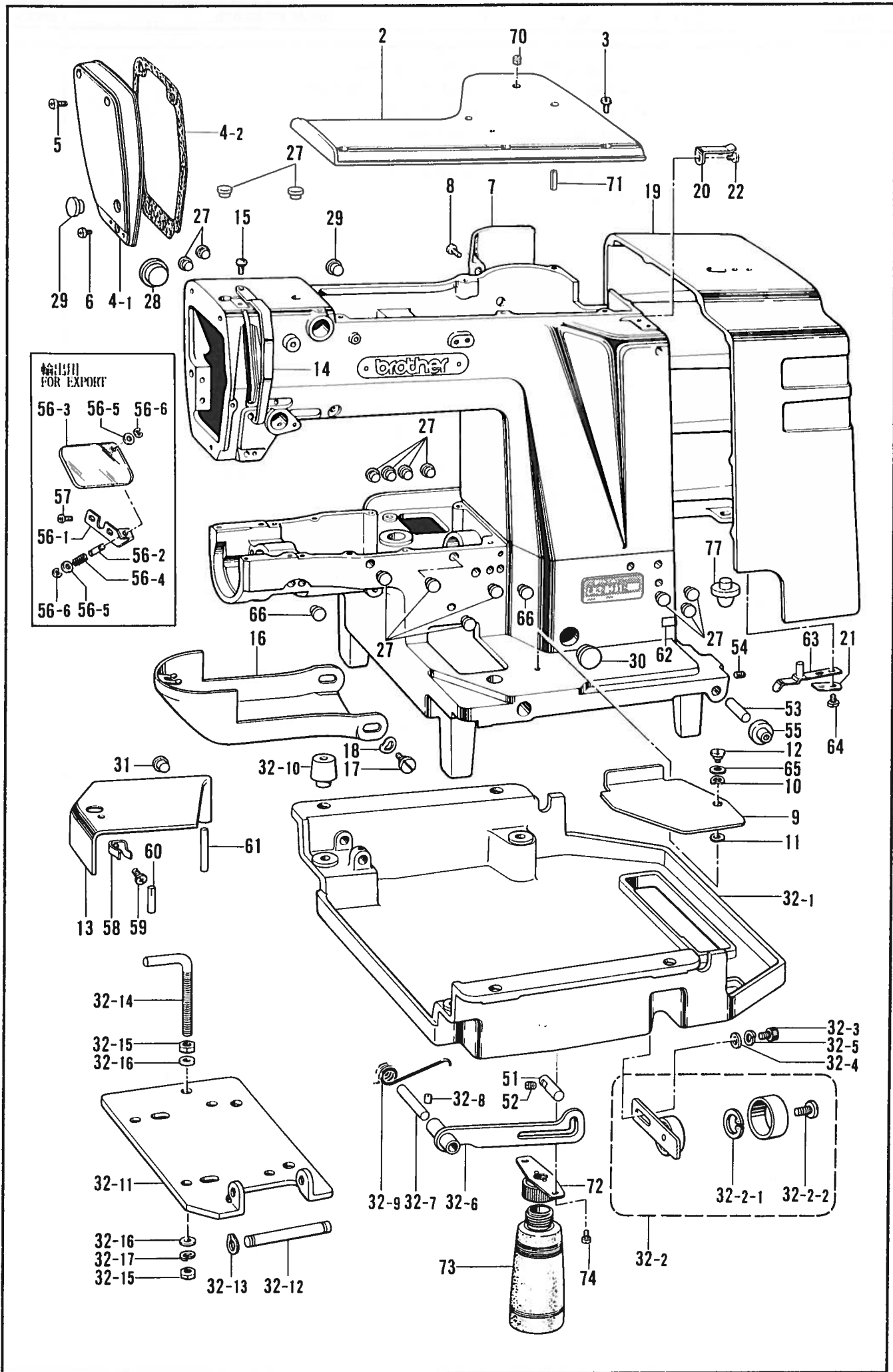

A. 主体関係 / Machine body / Maschinengehäuse / Corps de la machine / Cuerpo de la máquina

REF.NO.	CODE	Q'TY	ヒンメイ	NAME OF PARTS	RMKS
60	152838001	1	ミソ"ツキピン	DOWEL PIN	
61	152839001	1	ヘ"ツト"カハ"ーシ"ク	BED COVER SHAFT	
62	*	1	シヨウラヘル	LABEL	
63	152848001	1	ヘルトカハ"ーハ"ネ	BELT COVER SPRING	
64	062680812	2	ナヘ"コ437-40X8	SCREW 437X8	
65	025080132	1	ヒラサ"カ"ネシヨウ8	PLAIN WASHER 8	
66	104450109	2	メクラセン	OIL CAP	
70	154785000	2	フェルト	FELT	
71	047501242	2	スプリング"ピンAW5	SPRING PIN AW5	
72	154465001	1	ハイユキヤツフ"ササエクミ	DUST OILER SUPPORT ASSEMBLY	
73	114486002	1	ホ"リオイラータイ	OILER	
74	062710612	2	ナヘ"コ476-32X6	SCREW 476X6	
77	152847009	2	ヘルトカハ"ーゴ"ムサ"	PACKING	
<ヒョウジュンヨウ / STANDARD >					
19	152846009	1	ヘルトカハ"ー	BELT COVER	
<メカ2ペヨウ / MECHANICAL TWO PEDALS >					
19	154453009	1	ヘルトカハ"ーC	BELT COVER (C)	

B. クラッチ関係 / Clutch mechanism / Kupplungsvorrichtung /
Mécánisme de l'embrayage / Mecanismo de embrague

REF.NO.	CODE	Q'TY	ヒンメイ	NAME OF PARTS	RMKS
1	151886001	1	クラッチレハ"	CLUTCH LEVER	
2	151927001	1	クラッチフェルト	CLUTCH FELT	
3	151887001	1	クラッチレハ"-シ"ク	CLUTCH LEVER SHAFT	
4	048180142	1	トメフC18	STOP RING C18	
5	152756001	1	スラストサ"カ"ネ18	THRUST WASHER 18	
6	014821022	1	アナトメネシ"7.94クホ"ミ	SET SCREW 7.94	
7	151929000	1	スラストサ"カ"ネ18	THRUST WASHER 18	
8	152728001	1	スラストサ"カ"ネ8	THRUST WASHER 8	
9	151163001	1	アナホ"ルト8X15	BOLT 8X15	
10	151888101	1	ホ"ールオサエイタ	BALL PRESSER PLATE	
11	018082522	2	アナホ"ルト8X25	BOLT 8X25	
12	028080242	2	ハ"ネサ"カ"ネ2-8	SPRING WASHER 2-8	
13	115012002	1	トメネシ"6.35	SET SCREW 6.35	
14	150554002	1	ナツト6.35	NUT 6.35	
15	151889001	1	ストツハ"タイ	CLUTCH STOPPER	
16	151890000	1	ストツハ"ゴム	STOPPER RUBBER	
17	151891001	1	クラッチハ"ネ	CLUTCH SPRING	
18	151892001	2	ハ"ネウケ	SPRING HOOK	
19	115018001	2	カンシヨウゴム	CUSH ON RUBBER	
20	025800332	1	ヒラサ"カ"ネタ"イ7.14	PLAIN WASHER 7.14	
21	151893001	1	ストツハ"ジ"ク	STOPPER SHAFT	
22	021800102	1	ナツト1シユ7.14	NUT 7.14	
23	104689002	1	ナツト7.14	NUT 7.14	
24	151894101	1	ブ"レーキレハ"	BRAKE LEVER	
25	151895000	1	ブ"レーキクミ	BRAKE ASSEMBLY	
26	151898001	1	ブ"レーキジ"ク	BRAKE SHAFT	
27	048040342	2	トメフE4	STOP RING E4	
28	151899001	1	ブ"レーキシユ-ハ"ネ	SPRING	
29	151900001	1	ブ"レーキレハ"-シ"ク	BRAKE LEVER SHAFT	
30	142628001	2	スイハイオクリクランクリング"	FEED ROCK CRANK RING	
31	048110142	2	トメフシ"クヨウC11	STOP RING C11	
32	013761410	1	トメネシ"5.95クホ"ミ	SET SCREW 5.95	
33	151901001	1	ブ"レーキサト"-ヒ"ン	BRAKE DRIVING PIN	
34	014760622	1	アナトメネシ"5.95	SET SCREW 5.95	
35	151902001	1	ブ"レーキハ"ネ	BRAKE SPRING	
36	151903001	1	ブ"レーキハ"ネカケネシ"	BRAKE SPRING HOOK SCREW	
37	106147002	1	ナツト7.94	NUT 7.94	
38	110251001	1	ヌノオサエウテ"ハ"ネカケ	SPRING HOOK	
39	151904101	1	クラッチレハ"-レンカンクミ	CLUTCH LEVER ROD ASSEMBLY	
39-1	151905101	1	クラッチレハ"-レンカン	CLUTCH LEVER ROD	
39-2	107744001	1	コロ	ROLLER	
39-3	151906101	1	レンカンコロシ"ク	ROLLER SHAFT	
39-4	048030342	1	トメフE3	STOP RING E3	
39-5	113431002	1	サ"カ"ネ	WASHER	
39-6	025680132	1	ヒラサ"カ"ネシヨウ4.37	PLAIN WASHER 4.37	
39-7	021680202	1	ナツト2シユ4.37	NUT 4.37	
40	151907001	1	タ"ンネシ"5.95	STUD SCREW 5.95	
41	151908001	1	ナツト5.95	NUT 5.95	
42	155501001	1	クラッチレハ"-ハ"ネ	CLUTCH LEVER SPRING	
43	151910001	1	クラッチレハ"-ハ"ネカケ	CLUTCH LEVER SPRING HOOK	
44	117363001	2	ホ"ルト4.76	BOLT 4.76	
45	028050242	2	ハ"ネサ"カ"ネ2-5	SPRING WASHER 2-5	
46	152808101	1	チヨウセツツツ"クミ	ADJUST ROD ASSEMBLY	
46-1	154332001	1	オサエアケ"チヨウセツツツ"	PRESSER FOOT LIFTER ADJUST ROD	
46-2	154333001	1	オサエアケ"チヨウセツツツキ"テ	PRESSER FOOT LIFTER ADJUST JOINT	
46-3	150556001	1	ナツト6.35	NUT 6.35	
47	151912001	1	ヘンシンタ"ンネシ"6.35	STUD SCREW 6.35	
48	150556001	1	ナツト6.35	NUT 6.35	
49	151913001	1	タ"ンネシ"6.35	STUD SCREW 6.35	
50	151914001	1	カラ-13	COLLAR 13	
51	150556001	1	ナツト6.35	NUT 6.35	
52	151915101	1	クラッチサト"-レハ"-クミ	CLUTCH ACTUATING LEVER ASSEMBLY	

B. クラッチ関係 / Clutch mechanism / Kupplungsvorrichtung /
 Mécanisme de l'embrayage / Mecanismo de embrague

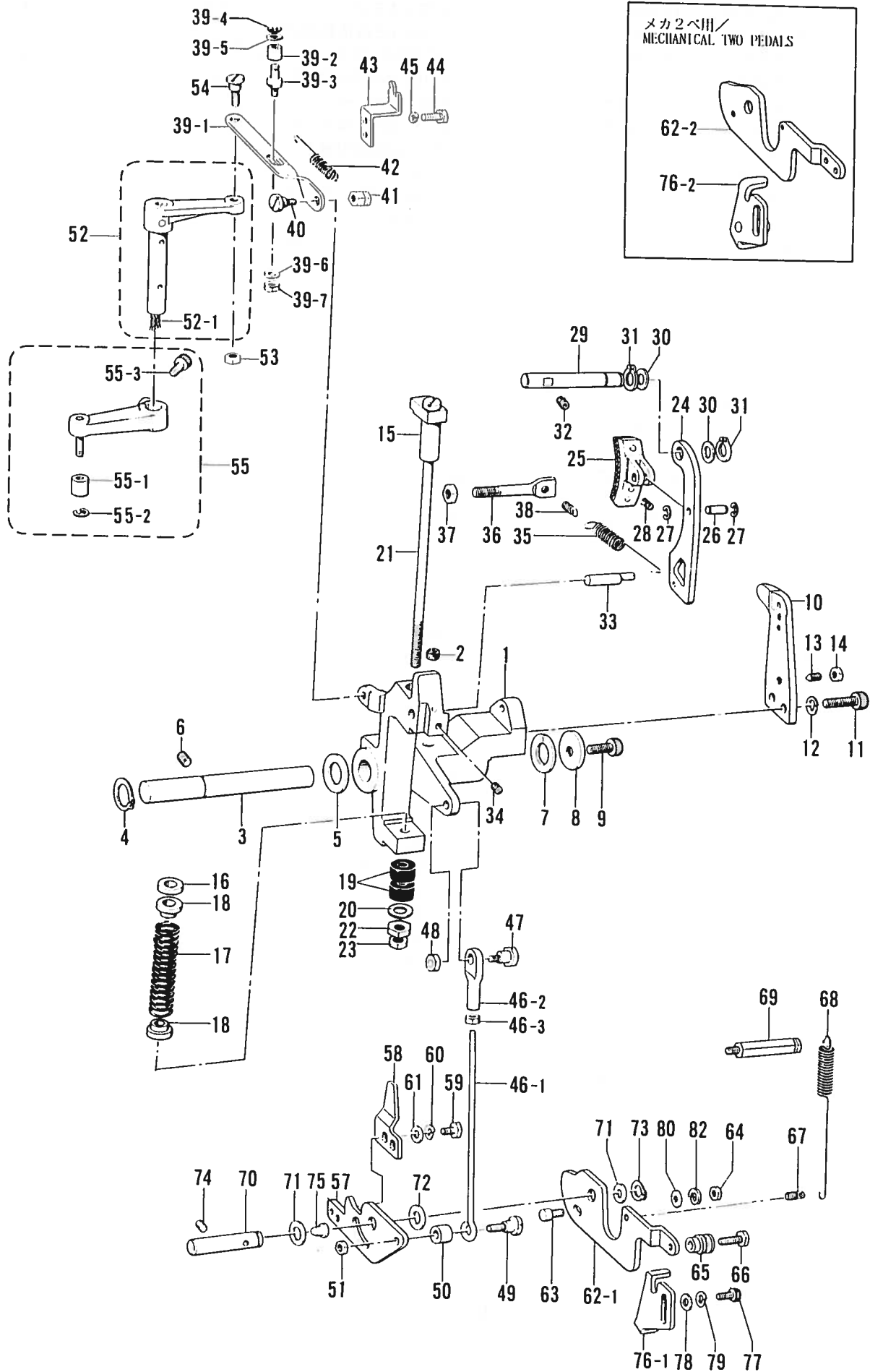

B. クラッチ関係 / Clutch mechanism / Kupplungsvorrichtung /
Mécanisme de l'embrayage / Mecanismo de embrague

REF.NO.	CODE	Q'TY	ヒンメイ	NAME OF PARTS	RMKS
52-1	152980001	1	クミヒモ6X6(15CM)	WICK 6X6 (15CM)	
53	150553001	1	ナツト5.95	NUT 5.95	
54	151907001	1	ダンネジ"5.95	STUD SCREW 5.95	
55	151939101	1	クラツチカムレハ"ークミ	CLUTCH CAM LEVER ASSEMBLY	
55-1	152914001	1	コロ	ROLLER	
55-2	048040342	1	トメフE4	STOP RING E4	
55-3	018062022	1	アナボ"ルト6X20	BOLT 6X20	
57	151919101	1	キト"ーレハ"ー	STARTING LEVER	
58	151920001	1	キト"ーセイフレハ"ー	STARTING SAFETY LEVER	
59	017711412	2	ボ"ルト4.76X14	BOLT 4.76X14	
60	028050242	2	ハ"ネサ"カ"ネ2-5	SPRING WASHER 2-5	
61	113431002	2	サ"カ"ネ	WASHER	
63	154155101	1	ストツハ"ネシ"	STOPPER SCREW	
64	150553001	1	ナツト5.95	NUT 5.95	
65	151922001	1	クサリカケカラ"ー	CHAIN HOOK COLLAR	
66	017762202	1	ボ"ルト5.95X22	BOLT 5.95X22	
67	110251001	1	ヌノオサエウチ"ハ"ネカケ	SPRING HOOK	
68	151923001	1	サト"ーレハ"ー"ハ"ネ	DRIVING LEVER SPRING	
69	151924001	1	サト"ーレハ"ー"ハ"ネカケ	DRIVING LEVER SPRING HOOK	
70	151925001	1	キト"ーレハ"ー"ジ"ク	STARTING LEVER SHAFT	
71	142628001	2	スイヘイオクリクランク"リング"	FEED ROCK CRANK RING	
72	110505001	1	サ"カ"ネ	WASHER	
73	048110142	1	トメフ"ジ"クヨウC11	STOP RING C11	
74	014760622	1	アナトメネジ"5.95	SET SCREW 5.95	
75	111865009	1	オイルメクラセン	OIL CAP	
77	018061622	2	アナボ"ルト6X16	BOLT 6X16	
78	025060132	2	ヒラサ"カ"ネシヨウ6	PLAIN WASHER 6	
79	028060242	2	ハ"ネサ"カ"ネ2-6	SPRING WASHER 2-6	
<ヒョウジュンヨウ / STANDARD >					
62-1	155499001	1	Pサト"ーレハ"ー	STARTING LEVER PLATE	
76-1	155500001	1	キト"ーストツハ"	STARTING LEVER STOPPER	
80	025060232	1	ヒラサ"カ"ネチヨウ6	PLAIN WASHER 6	
82	028060242	1	ハ"ネサ"カ"ネ2-6	SPRING WASHER 2-6	
<メカ2ペヨウ / MECHANICAL TWO PEDALS >					
62-2	154450001	1	Pサト"ーレハ"ーB	RELEASE DRIVE LEVER B	
76-2	154451001	1	キト"ーウストツハ"B	DRIVE STOPPER B	

C. 上軸・針棒関係/Upper shaft and needle bar mechanism/Obere Welle und Nadelstangenvorrichtung/
 Mécanisme de arbre supérieur et barre à aiguille/Mecanismo del eje superior y la barra de aguja

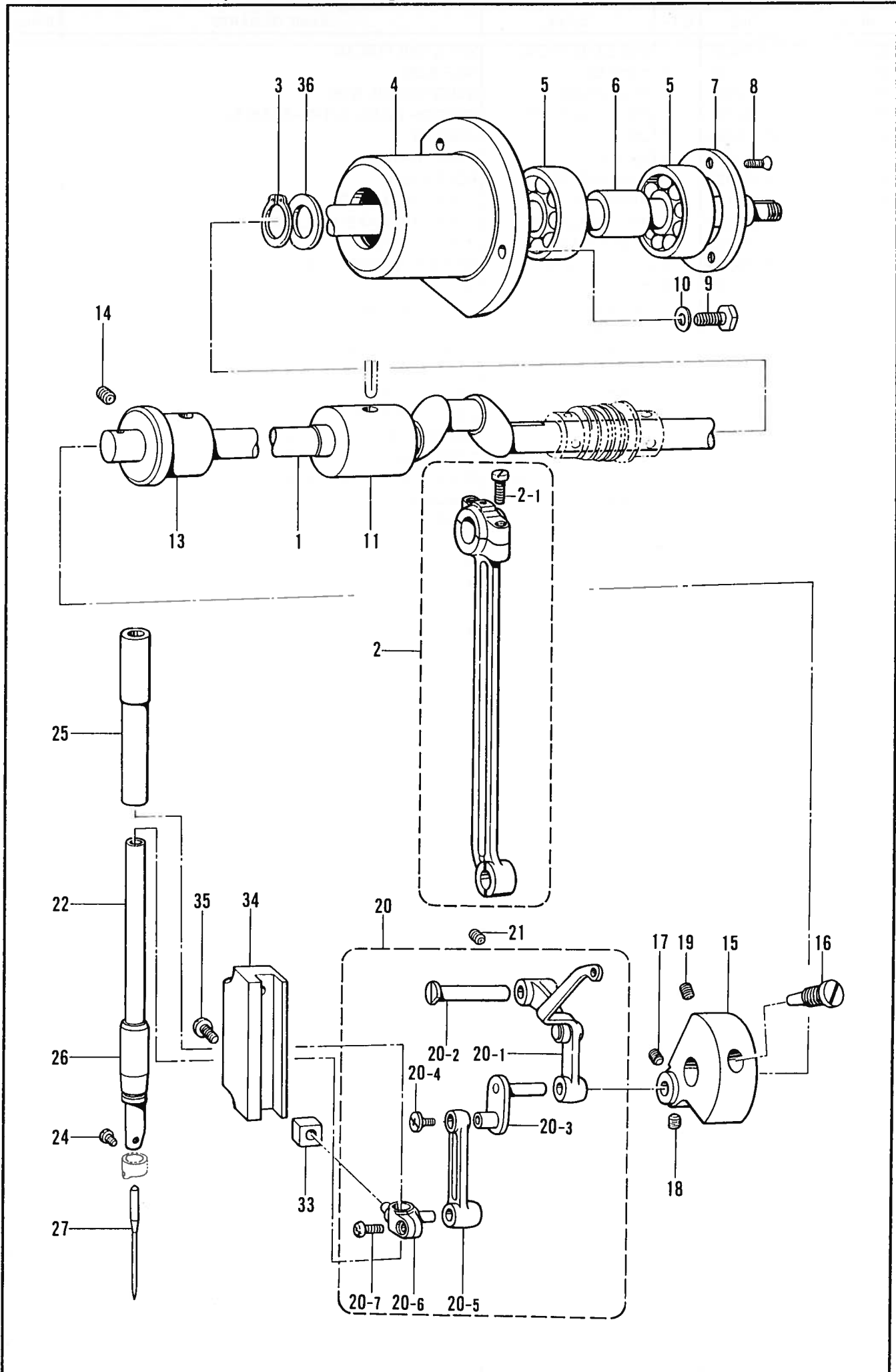

C. 上軸・針棒関係/Upper shaft and needle bar mechanism/Obere Welle und Nadelstangenvorrichtung/
Mécanisme de arbre supérieur et barre à aiguille/Mecanismo del eje superior y la barra de aguja

REF.NO.	CODE	Q'TY	ヒンメイ	NAME OF PARTS	RMKS
1	151995001	1	ウツシ"ク	UPPER SHAFT	
2	153040001	1	クランクロッド"クミ	CRANK ROD ASSEMBLY	
2-1	144712002	2	シメネシ"4.76	SCREW 4.76	
3	048150142	1	トメフシ"クヨウC15	STOP RING C15	
4	151997000	1	タマシ"クウケケース	BALL BEARING CASE	
5	072630260	2	へ"アリンク"6302VV	BEARING 6302VV	
6	151998000	1	へ"アリンク"カンザ"	BEARING COLLAR	
7	151999001	1	タマシ"クウケフタ	BALL BEARING CAP	
8	102843004	3	サラネシ"3.57	SCREW 3.57	
9	017761412	3	ボ"ルト5.95X14	BOLT 5.95X14	
10	025060232	3	ヒラサ"カ"ネチユウ6	PLAIN WASHER 6	
11	140726000	1	ウツシ"クメタルM	UPPER SHAFT BUSH (M)	
13	152000001	1	ウツシ"クメタルF	UPPER SHAFT BUSH (F)	
14	013761412	1	トメネシ"5.95クホ"ミ	SET SCREW 5.95	
15	152231000	1	ツリアイクランク	COUNTER WEIGHT	
16	100250001	1	シメネシ"7.14	SCREW 7.14	
17	014770622	1	アナトメネシ"6.35クホ"ミ	SET SCREW 6.35	
18	101706001	1	トメネシ"6.35	SET SCREW 6.35	
19	014770622	1	アナトメネシ"6.35クホ"ミ	SET SCREW 6.35	
20	152232001	1	ハリホ"ウレンカンクミ	THREAD TAKE-UP LEVER ASSEMBLY	
20-1	153330001	1	デンビ"ンクミ	THREAD TAKE-UP ASSEMBLY	
20-2	152236001	1	デンビ"ンササエシ"ク	THREAD TAKE-UP SUPPORT STUD	
20-3	152237001	1	ハリホ"ウクランク	NEEDLE BAR CRANK	
20-4	132051001	1	+ サラネシ"3.57L	SCREW 3.57L	
20-5	152238001	1	ハリホ"ウレンカン	NEEDLE BAR CONNECTOR	
20-6	152239001	1	ハリホ"ウタ"キ	NEEDLE BAR CLAMP	
20-7	062680812	1	ナヘ"コ437-40X8	SCREW 437X8	
21	013761412	1	トメネシ"5.95クホ"ミ	SET SCREW 5.95	
22	152240001	1	ハリホ"ウA	NEEDLE BAR (A)	
24	144458001	1	アタマツキトメネシ"3.57	SET SCREW 3.57	
25	152242001	1	ハリホ"ウメタルU	NEEDLE BAR BUSH (U)	
26	152243001	1	ハリホ"ウメタルD	NEEDLE BAR BUSH (D)	
27	107415016	1	ミシンハリDPX5(#16)	NEEDLE DPX5 (#16)	
33	142211001	1	カクコマ	SLIDE BLOCK	
34	152244000	1	ハリホ"ウアンナイ	NEEDLE BAR GUIDE	
35	062781412	2	ナヘ"コ635-28X14	SCREW 635X14	
36	116920001	1	オクリシ"クスラストリンク"	THRUST RING	

D. 送り関係/Feed mechanism/Transportvorrichtung/
 Mécanisme de l'entraînement/Mecanismo de la alimentación

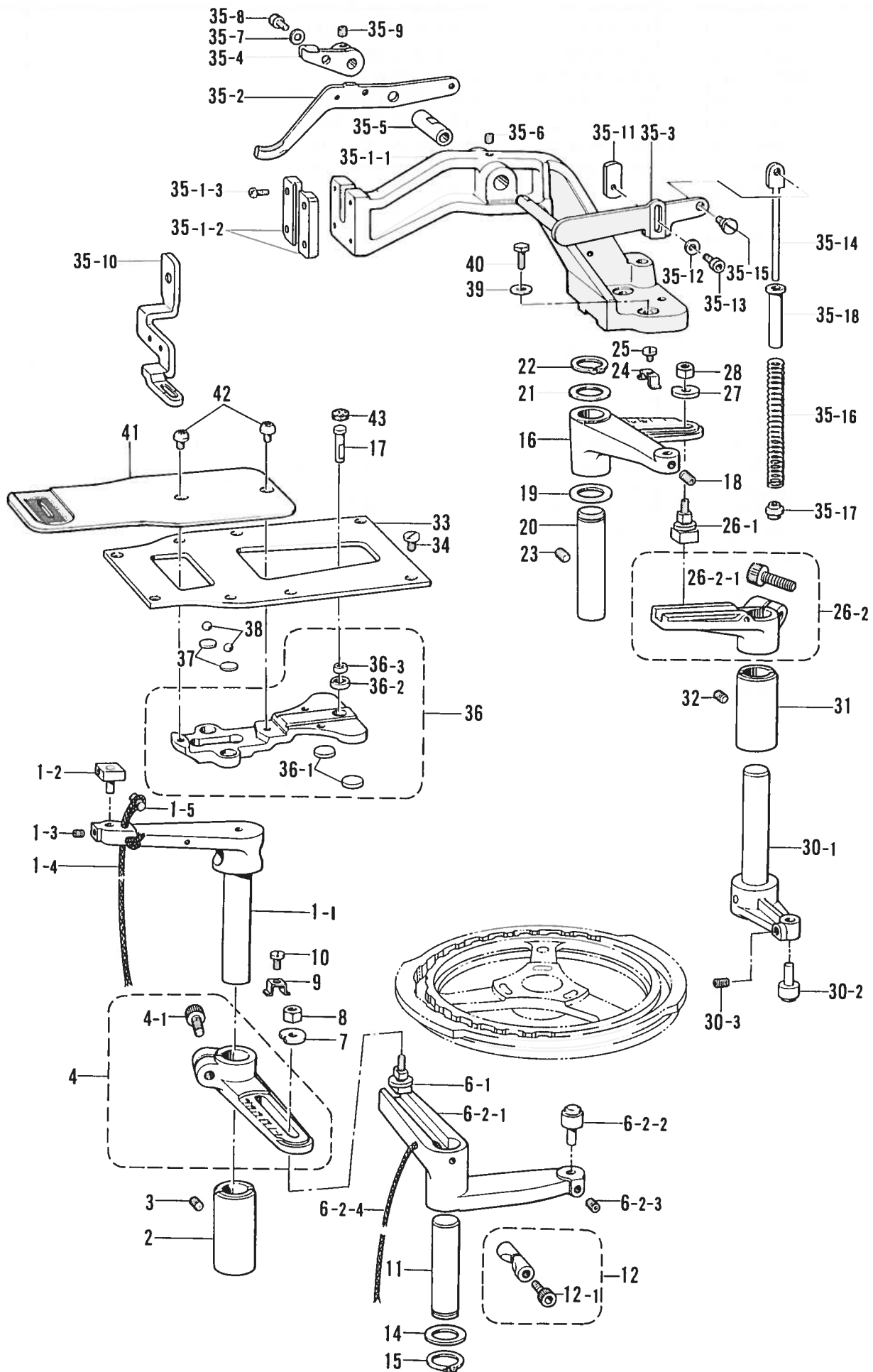

D. 送り関係/Feed mechanism/Transportvorrichtung/
Mécanisme de l'entraînement/Mecanismo de la alimentación

REF NO.	CODE	Q'TY	ヒンメイ	NAME OF PARTS	RMKS
1	152741101	1	ヨコオクリレハ"ークミ	TACK LENGTH LEVER ASSEMBLY	
1-1	152742001	1	ヨコオクリレハ"	TACK LENGTH LEVER	
1-2	153041001	1	ヨコオクリカクコ"マクミ	TACK LENGTH SLIDE BLOCK ASSEMBLY	
1-3	151602002	1	トメネシ"4.37	SET SCREW 4.37	
1-4	153924001	1	フェルト	FELT	
1-5	153921001	1	クミヒモ4X4 (15CM)	WICK 4X4 (15CM)	
2	152745001	1	オクリメタル	FEED BUSH	
3	014760622	1	アナトメネシ"5.95	SET SCREW 5.95	
4	153762101	1	ヨコチヨウセツレハ"ークミ	TACK LENGTH REGULATOR LEVER ASSEMBLY	
4-1	018082022	1	アナホ"ルト8X20	BOLT 8X20	
6-1	153042001	1	オクリチヨウセツシ"ククミ	TACK REGULATOR SHAFT ASSEMBLY	
6-2-1	152752001	1	ヨコオクリカムレハ"	TACK LENGTH LEVER	
6-2-2	153043001	1	オクリカムコロシ"ククミ	FEED CAM ROLLER SHAFT ASSEMBLY	
6-2-3	014760622	1	アナトメネシ"5.95	SET SCREW 5.95	
6-2-4	152980001	1	クミヒモ6X6 (15CM)	WICK 6X6 (15CM)	
7	152749001	1	オクリチヨウセツサ"カ"ネ	WASHER	
8	152750001	1	オクリチヨウセツナツト	FEED REGULATOR NUT	
9	153045001	1	オクリレハ"ー"ストツハ°	TACK LENGTH LEVER STOPPER	
10	105451002	1	シメネシ"3.57	SCREW 3.57	
11	152755001	1	ヨコオクリカムレハ"ー"シ"ク	TACK LENGTH LEVER SHAFT	
12	S09132001	1	ピンチスリーブ"クミ	PINCH SLEEVE ASSEMBLY	
12-1	018063022	1	アナホ"ルト6X30	BOLT 6X30	
14	152756001	1	スラストサ"カ"ネ18	THRUST WASHER 18	
15	048180142	1	トメフC18	STOP RING C18	
16	152758001	1	タテオクリレハ"	TACK WIDTH LEVER	
17	152759001	1	タテオクリシ"ク	TACK WIDTH FEED SHAFT	
18	014760622	1	アナトメネシ"5.95	SET SCREW 5.95	
19	152756001	1	スラストサ"カ"ネ18	THRUST WASHER 18	
20	152760001	1	タテオクリレハ"ー"シ"ク	TACK WIDTH LEVER SHAFT	
21	152756001	1	スラストサ"カ"ネ18	THRUST WASHER 18	
22	048180142	1	トメフC18	STOP RING C18	
23	014760622	1	アナトメネシ"5.95	SET SCREW 5.95	
24	153045001	1	オクリレハ"ー"ストツハ°	TACK LENGTH LEVER STOPPER	
25	105451002	1	シメネシ"3.57	SCREW 3.57	
26-1	153042001	1	オクリチヨウセツシ"ククミ	TACK REGULATOR SHAFT ASSEMBLY	
26-2	153757001	1	タテチヨウセツレハ"ークミ	TACK WIDTH REGULATOR LEVER ASSEMBLY	
26-2-1	018082022	1	アナホ"ルト8X20	BOLT 8X20	
27	152749001	1	オクリチヨウセツサ"カ"ネ	WASHER	
28	152750001	1	オクリチヨウセツナツト	FEED REGULATOR NUT	
30	152762001	1	タテオクリカムレハ"ークミ	TACK LENGTH CAM LEVER ASSEMBL	
30-1	153331001	1	タテオクリカムレハ"シ"ククミ	TACK WIDTH FEED SHAFT ASSEMBLY	
30-2	153043001	1	オクリカムコロシ"ククミ	FEED CAM ROLLER SHAFT ASSEMBLY	
30-3	014760622	1	アナトメネシ"5.95	SET SCREW 5.95	
31	152745001	1	オクリメタル	FEED BUSH	
32	014760622	1	アナトメネシ"5.95	SET SCREW 5.95	
33	152766001	1	オクリタ"イアンナイイタ	FEED BAR GUIDE PLATE	
34	145318001	8	シメネシ"4.37	SCREW 4.37	
35	*	1	オサエウテ"クミ431	PRESSER ARM ASSEMBLY 431	
35-1	159826009	1	オサエウテ"クミコ	PRESSER ARM ASSEMBLY	
35-1-1	159825009	1	オサエウテ"431	PRESSER ARM 431	
35-1-2	159827001	2	オサエアシオサエイタB	WORK CLAMP GUIDE BRACKET (B)	
35-1-3	062671212	4	ナヘ"コ357-40X12	SCREW 357X12	
35-2	154413001	1	オサエウテ"レハ"ーA	PRESSER ARM LEVER (A)	
35-3	154414001	1	オサエウテ"レハ"ーB	PRESSER ARM LEVER (B)	
35-4	154415001	1	オサエウテ"レハ"ーC	PRESSER ARM LEVER (C)	
35-5	153944001	1	レハ"ー"シ"クメタル	LEVER SHAFT BUSHING	
35-6	014760622	1	アナトメネシ"5.95	SET SCREW 5.95	
35-7	140407002	1	サ"カ"ネ	WASHER	
35-8	018500822	1	アナホ"ルト5X8	BOLT 5X8	
35-9	014770622	2	アナトメネシ"6.35クホ"ミ	SET SCREW 6.35	
35-10	*	1	オサエアシ431	WORK CLAMP FOR B431	
35-11	153571001	1	オサエウテ"レハ"ーイタ	PRESSER ARM LEVER PLATE	

D. 送り関係 / Feed mechanism / Transportvorrichtung /
 Mécanisme de l'entraînement / Mecanismo de la alimentación

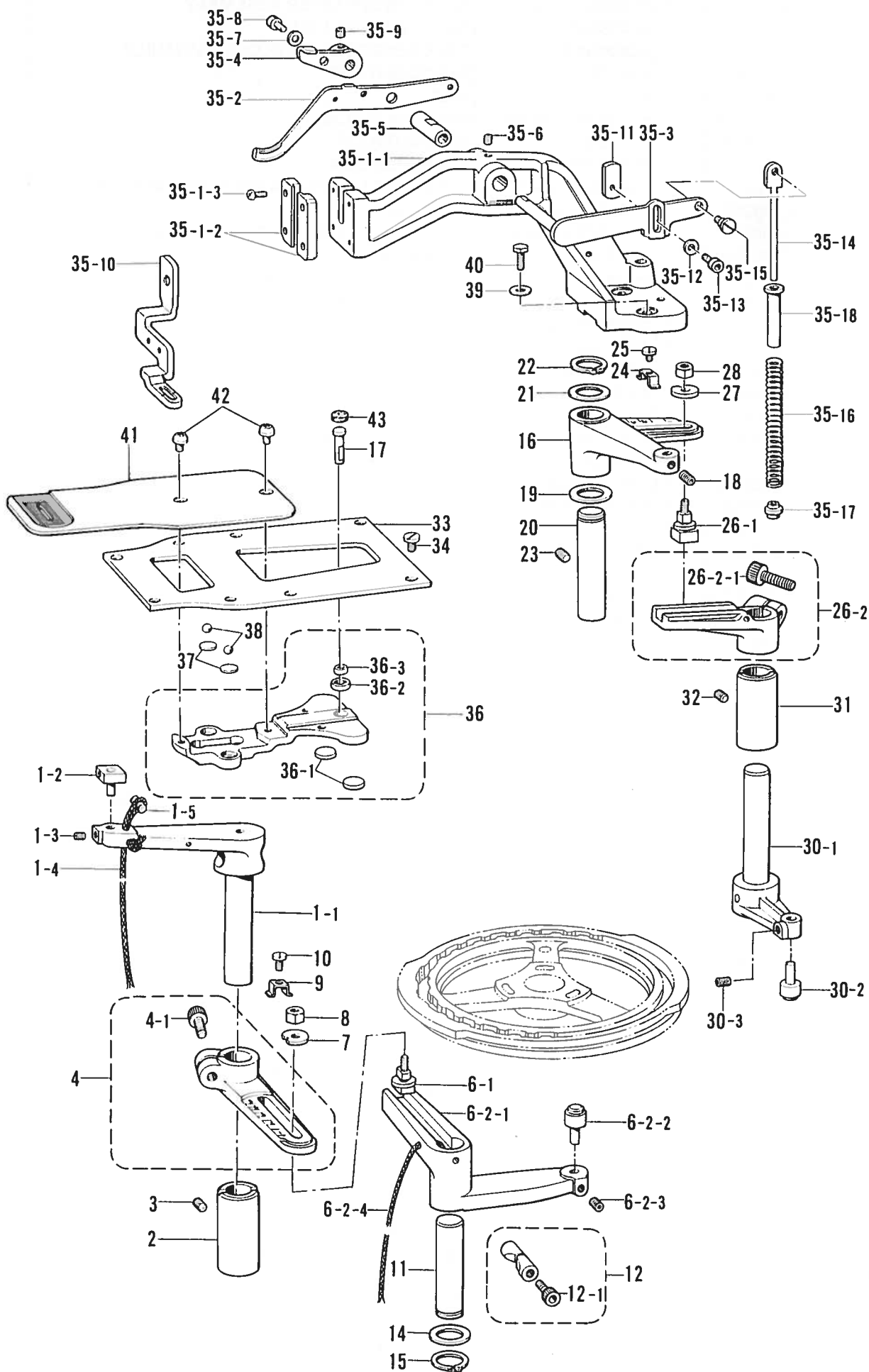

D. 送り関係 / Feed mechanism / Transportvorrichtung /
 Mécanisme de l'entraînement / Mecanismo de la alimentación

REF.NO.	CODE	Q'TY	ヒンメイ	NAME OF PARTS	RMKS
35-12	140407002	1	サ"カ"ネ	WASHER	
35-13	018500822	1	アナボ"ルト5X8	BOLT 5X8	
35-14	159828001	1	オサエハ"ネアンナイロツト"B	PRESSER SPRING GUIDE ROD B	
35-15	145478001	1	タ"ンネジ"4.76	STUD SCREW 4.76	
35-16	154418001	1	オサエハ"ネ431	PRESSER SPRING FOR B431	
35-17	152788000	1	オサエハ"ネカンサ"	PRESSER SPRING COLLAR	
35-18	153567000	1	オサエハ"ネカラー	PRESSER SPRING COLLAR	
36	152769001	1	オクリタ"イクミ	FEED BAR GUIDE ASSEMBLY	
36-1	152771000	2	オクリタ"イカンサ"	COLLAR	
36-2	152773000	1	キユウメンフ"ツシユメタル	BUSH	
36-3	141331001	1	キユウメンフ"シユ	BUSH	
37	152772001	2	カンサ"	WASHER	
38	071047650	2	コウキユウ3/16	STEEL BALL 3/16	
39	025060232	2	ヒラサ"カ"ネチユウ6	PLAIN WASHER 6	
40	017761412	2	ボ"ルト5.95X14	BOLT 5.95X14	
42	153057002	2	オクリイタシメネジ"	SCREW	
43	153035000	1	オサエウデ"フェルト	PRESSER ARM FELT	
<-1,-2>					
41	154419201	1	オクリイタ431-S	FEED PLATE FOR B431-S	
<-3>					
41	154420201	1	オクリイタ431-L	FEED PLATE FOR B431-L	

E. 押工上げ関係 / Work clamp lifter mechanism / Stoffhalterhebevorrichtung /
 Mécanisme de levier du pinceur / Mecanismo del levantador de ménsula de trabajo

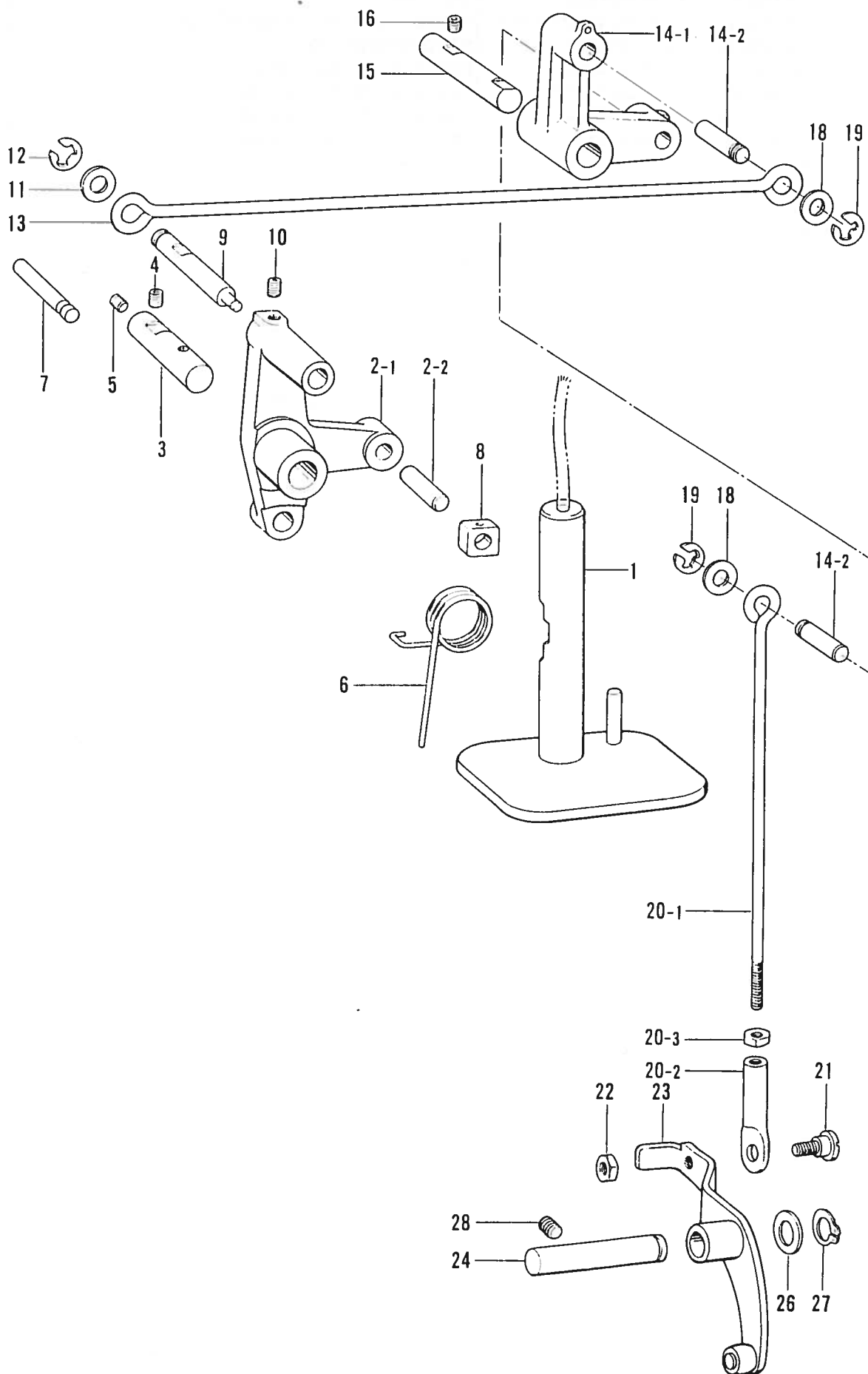

E. 押工上げ関係 / Work clamp lifter mechanism / Stoffhalterhebevorrichtung /
 Mécanisme de leveur du pinceur / Mecanismo del levantador de ménsula de trabajo

REF.NO.	CODE	Q'TY	ヒンメイ	NAME OF PARTS	RMKS
1	152794001	1	オサエアケ"イタクミ	WORK CLAMP LIFTER PLATE ASSEMBLY	
2-1	152798001	1	オサエアケ"レハ"	WORK CLAMP LIFTER LEVER	
2-2	152744001	1	ヨコオクリカクゴ"マヒン	TACK LENGTH SLIDE BLOCK PIN	
3	152799001	1	オサエアケ"レハ"ーシ"ク	WORK CLAMP LIFTER LEVER SHAFT	
4	014760622	1	アナトメネシ"5.95	SET SCREW 5.95	
5	013760612	1	トメネシ"5.95クホ"ミ	SET SCREW 5.95	
6	152800201	1	オサエアケ"ハ"ネ	SPRING	
7	152801001	1	ハ"ネカケヒ"ン	SPRING HOOK PIN	
8	102630001	1	ハリホ"ウアンナイカクコマ	NEEDLE BAR GUIDE SLIDE BLOCK	
9	152802001	1	オサエアケ"ロツト"シ"クA	WORK CLAMP LIFTER ROD SHAFT (A)	
10	014760622	1	アナトメネシ"5.95	SET SCREW 5.95	
11	107153002	1	サ"カ"ネ	WASHER	
12	048060342	1	トメフE6	STOP RING E6	
13	152803001	1	オサエアケ"ロツト"A	WORK CLAMP LIFTER ROD (A)	
14-1	152805101	1	オサエアケ"レンケツレハ"ー	CONNECTING LEVER	
14-2	152806001	2	オサエアケ"ロツト"シ"クB	CONNECTING LEVER SHAFT (B)	
15	158686001	1	レンケツレハ"ーシ"ク	LIFTING LEVER SHAFT	
16	014760622	1	アナトメネシ"5.95	SET SCREW 5.95	
18	107153002	2	サ"カ"ネ	WASHER	
19	048060342	2	トメフE6	STOP RING E6	
20	152808101	1	チヨウセツロツト"クミ	ADJUST ROD ASSEMBLY	
20-1	154332001	1	オサエアケ"チヨウセツロツト"	PRESSER FOOT LIFTER ADJUST ROD	
20-2	154333001	1	オサエアケ"チヨウセツツキ"テ	PRESSER FOOT LIFTER ADJUST JOINT	
20-3	150556001	1	ナツト6.35	NUT 6.35	
21	141583001	1	タ"ンネシ"6.35	STUD SCREW 6.35	
22	150556001	1	ナツト6.35	NUT 6.35	
23	152811001	1	サト"ウレハ"ー"クミ	CONNECTING LEVER ASSEMBLY	
24	158687001	1	サト"ウレハ"ー"シ"ク	DRIVING SHAFT	
26	142628001	1	スイハイオクリクランクリンク"	FEED ROCK CRANK RING	
27	048110142	1	トメフシ"クヨウC11	STOP RING C11	
28	014760622	1	アナトメネシ"5.95	SET SCREW 5.95	

F. カム伝導関係 / Vertical shaft mechanism / Vertikale Welle /
 Mécanisme d'arbre vertical / Mecanismo del eje vertical

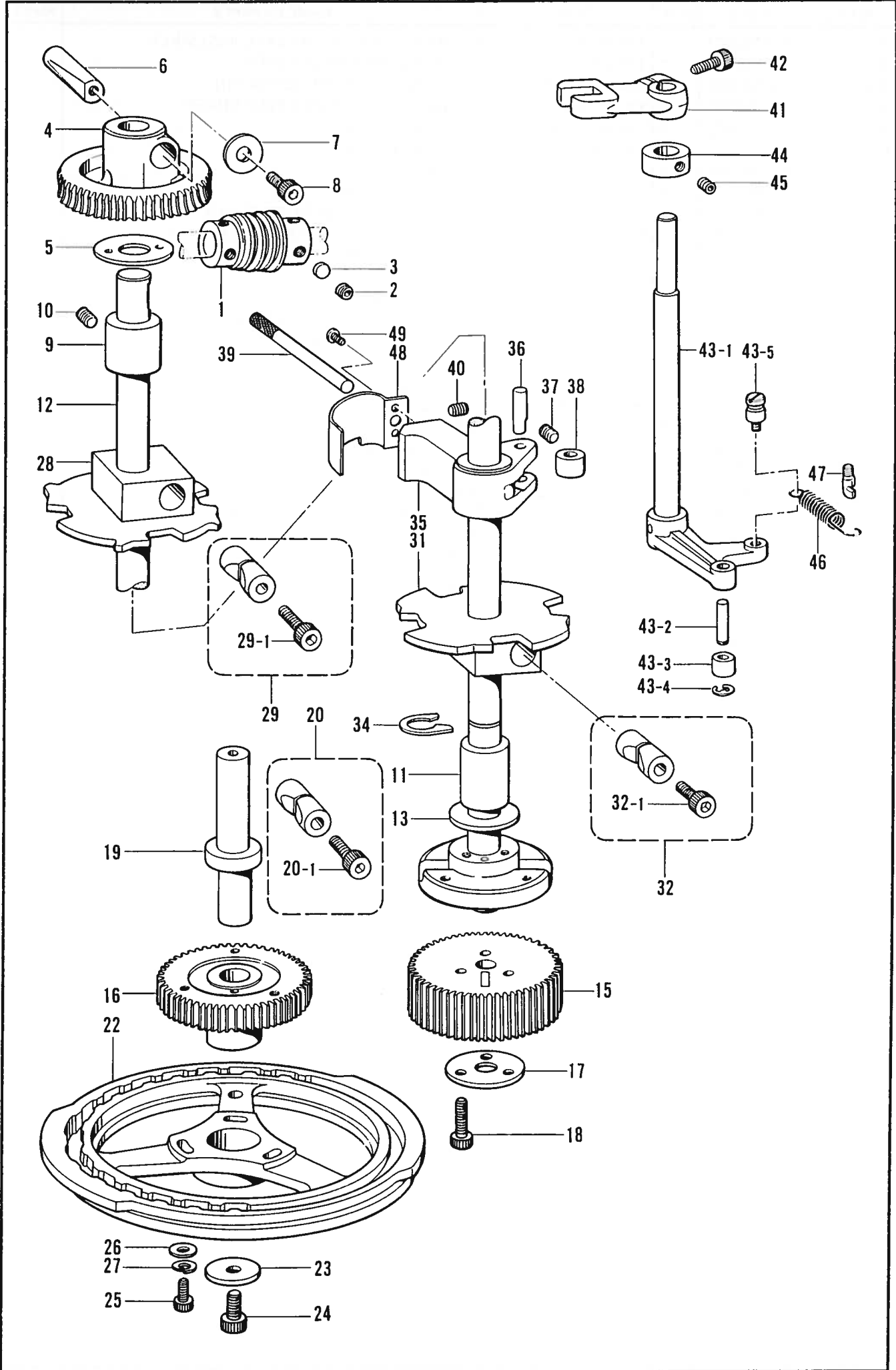

F. カム伝導関係 / Vertical shaft mechanism / Vertikale Welle /
Mécanisme d'arbre vertical / Mecanismo del eje vertical

REF.NO.	CODE	Q'TY	ヒンメイ	NAME OF PARTS	RMKS
1	152707001	1	ウオーム	WORM	
2	152718001	6	アナトメネジ"5.95	SET SCREW 5.95	
3	147151000	1	トメサ"カ"ネ	WASHER	
4	152708000	1	ウオームホイール	WORM WHEEL	
5	152713001	1	スラストサ"カ"ネ	THRUST WASHER	
6	152709000	1	スリーブ"	SLEEVE	
7	152710001	1	サ"カ"ネ	WASHER	
8	018062022	1	アナボ"ルト6X20	BOLT 6X20	
9	159977000	1	タデシ"クメタルU	VERTICAL SHAFT BUSH (U)	
10	014760622	1	アナトメネジ"5.95	SET SCREW 5.95	
11	159978001	1	タデシ"クメタルL	VERTICAL SHAFT BUSH (L)	
12	159979001	1	タデシ"クソウクミ	VERTICAL SHAFT UNIT	
13	159984001	1	スラストサ"カ"ネ40	THRUST WASHER 40	
15	*	1	チェンシ"キ"ヤW	CHANGE GEAR (W)	
16	*	1	チェンシ"キ"ヤC	CHANGE GEAR (C)	
17	153104001	1	チェンシ"キ"ヤサ"カ"ネ	WASHER	
18	018062222	3	アナボ"ルト6X22	BOLT 6X22	
19	152724001	1	カムシ"ク	TACK LENGTH FEED CAM SHAFT	
20	S09132001	1	ピンチスリーブ"クミ	PINCH SLEEVE ASSEMBLY	
20-1	018063022	1	アナボ"ルト6X30	BOLT 6X30	
22	*	1	オクリカム431	FEED CAM FOR B431	
23	152728001	1	スラストサ"カ"ネ8	THRUST WASHER 8	
24	151163001	1	アナボ"ルト8X15	BOLT 8X15	
25	018062022	3	アナボ"ルト6X20	BOLT 6X20	
26	109893002	3	サ"カ"ネ	WASHER	
27	028060242	3	ハ"ネサ"カ"ネ2-6	SPRING WASHER 2-6	
28	152729001	1	クラツチカム	CLUTCH CAM	
29	S09132001	1	ピンチスリーブ"クミ	PINCH SLEEVE ASSEMBLY	
29-1	018063022	1	アナボ"ルト6X30	BOLT 6X30	
31	S07814001	1	イトキリカムSP	KNIFE CAM (SP)	
32	S09132001	1	ピンチスリーブ"クミ	PINCH SLEEVE ASSEMBLY	
32-1	018063022	1	アナボ"ルト6X30	BOLT 6X30	
34	152723001	1	イトキリカムトメリング"	STOP RING	
35	152731001	1	セイキ"ヨタイ	ROLLER HOLDER	
36	152732001	1	セイキ"ヨタイコロシ"ク	ROLLER SHAFT	
37	013710712	1	トメネジ"4.76クホ"ミ	SET SCREW 4.76	
38	152914001	1	コロ	ROLLER	
39	152733001	1	ヒシ"ヨウテイシレハ"ー	EMERGENCY STOP LEVER	
40	013710712	1	トメネジ"4.76クホ"ミ	SET SCREW 4.76	
41	152734001	1	セイキ"ヨレハ"ー	ROLLER HOLDER LEVER	
42	018061622	1	アナボ"ルト6X16	BOLT 6X16	
43	152735101	1	セイキ"ヨカムレハ"ークミ	ROLLER HOLDER CAM LEVER ASSEMBLY	
43-1	153332001	1	セイキ"ヨレハ"ーシ"ククミ	POLLER FOLDER LEVER SHAFT ASSEMBLY	
43-2	152739001	1	コロシ"ク	ROLLER SHAFT	
43-3	153195001	1	コロ	ROLLER	
43-4	048040342	1	トメフE4	STOP RING E4	
43-5	155337001	1	ハ"ネカケ	SPRING HOOK	
44	110027001	1	セツトカラー	SET COLLAR	
45	014760622	2	アナトメネジ"5.95	SET SCREW 5.95	
46	155336001	1	セイキ"ヨハ"ネ	SPRING	
47	141334001	1	ハ"ネカケ	SPRING HOOK	
48	153141001	1	セイキ"ヨタイカハ"ー	ROLLER HOLDER COVER	
49	062670412	2	ナヘ"コ357-40X4	SCREW 357X4	

G. パワー押工関係/Power lift mechanism/Heberbetätigungsverrichtung/
 Mécanisme de leveur/Mecanismo de carreta de potencia

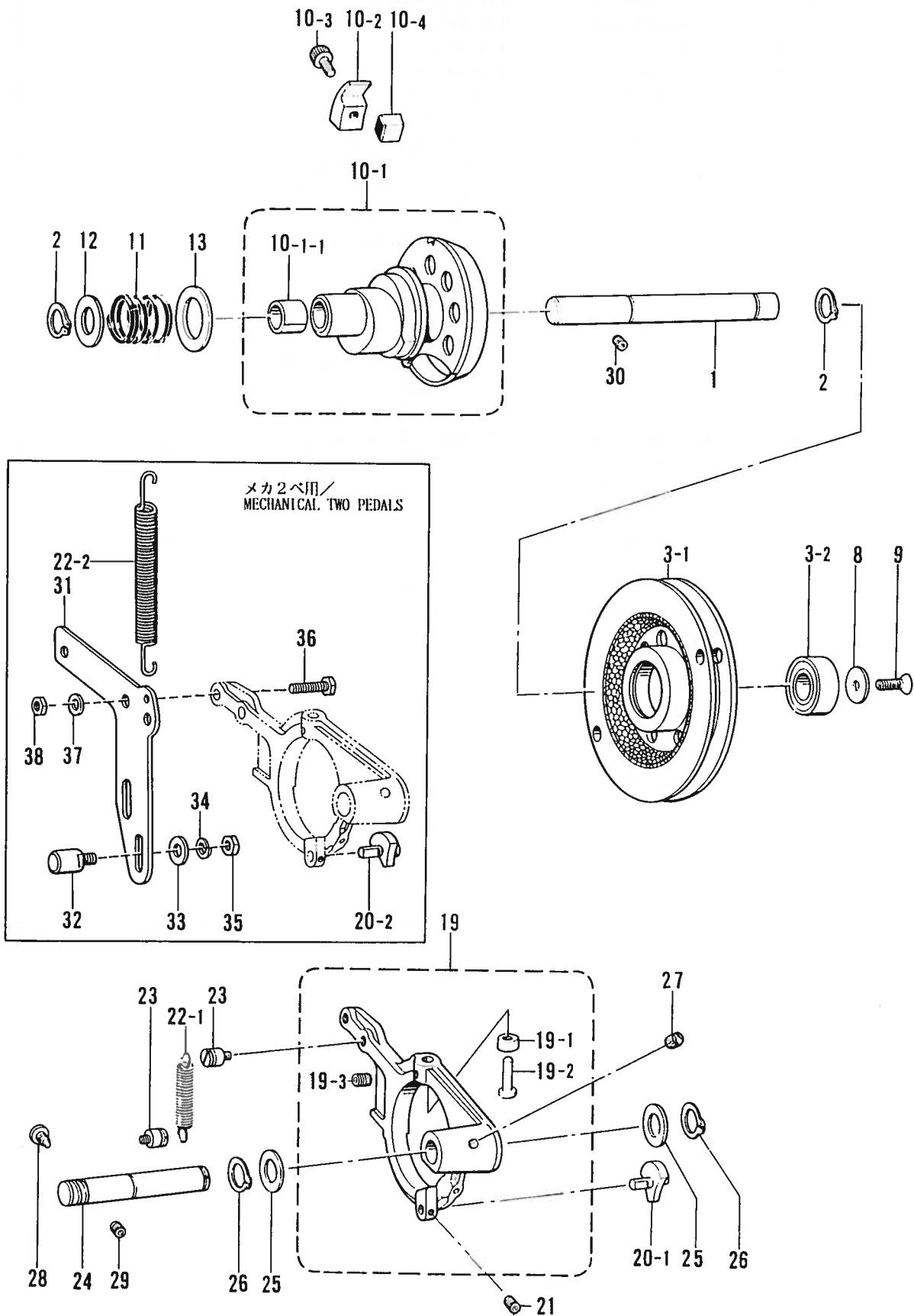

G. パワー押工関係 / Power lift mechanism / Heberbetätigungsverrichtung /
 Mécanisme de levreur / Mecanismo de carreta de potencia

REF.NO.	CODE	Q'TY	ヒンメイ	NAME OF PARTS	RMKS
1	151928001	1	Pプーリジ"ク	POWER PULLEY SHAFT	
2	048170142	2	トメワジ"クヨウC17	STOP RING C17	
3	156936101	1	Pプーリソウクミ	POWER PULLEY SET	
3-1	151930201	1	Pプーリクミ	POWER PULLEY ASSEMBLY	
3-2	072600360	1	タマシ"クウケ6003VV	BALL BEARING 6003VV	
8	151932001	1	シ"クウケフタ	BEARING COVER	
9	107231002	1	サラネシ"4.76	SCREW 4.76	
10	155523001	1	ハ"ワーカムセツト	POWER CAM SET	
10-1	151933001	1	ハ"ワーカムクミ	POWER CAM ASSEMBLY	
10-1-1	151935000	2	DVブ"ツシユ	(DV) BUSH	
10-2	151940001	1	ハ"ワーカムストツハ"A	POWER CAM STOPPER (A)	
10-3	018060822	1	アナホ"ルト6X8	BOLT 6X8	
10-4	151941101	1	ハ"ワーカムストツハ"Bクミ	POWER CAM STOPPER (B) ASSEMBLY	
11	151936001	1	Pクラツチハ"ネ	POWER CLUTCH SPRING	
12	151937001	1	スラストサ"ガ"ネ17	THRUST WASHER 17	
13	151938001	1	サ"ガ"ネ	WASHER	
19	151944001	1	ク"ト"ーレハ"ー"クミ	CLUTCH ACTUATING LEVER ASSEMBLY	
19-1	151947101	2	コロ11	ROLLER (11)	
19-2	151948001	2	ク"ト"ーレハ"ー"コロシ"ク	ROLLER SHAFT	
19-3	014760622	2	ア"ナ"トメネシ"5.95	SET SCREW 5.95	
21	014760622	1	ア"ナ"トメネシ"5.95	SET SCREW 5.95	
24	151952001	1	ク"ト"ーレハ"ー"シ"ク	CLUTCH ACTUATING LEVER SHAFT	
25	151953001	2	スラストサ"ガ"ネ16	THRUST WASHER 16	
26	048160142	2	トメワジ"クヨウC16	STOP RING C16	
27	107149001	1	フェルト	FELT	
28	151954001	1	ア"ン"ナイヒ"ンネシ"	GUIDE PIN SCREW	
29	014821022	1	ア"ナ"トメネシ"7.94クホ"ミ	SET SCREW 7.94	
30	014760622	1	ア"ナ"トメネシ"5.95	SET SCREW 5.95	
<ヒョウジュンヨウ / STANDARD >					
20-1	151949001	1	オ"サ"エアケ"コロシ"ククミ	ROLLER SHAFT ASSEMBLY	
22-1	151951001	1	ク"ト"ーレハ"ー"ヒキハ"ネ	DRIVING LEVER COIL SPRING	
23	141472002	2	シ"タイトキリレハ"ー"ハ"ネカケ	SPRING HOOK	
<メカ2ベヨウ / MECHANICAL TWO PEDALS >					
20-2	154681001	1	オ"サ"エアケ"コロシ"ククミB	ROLLER SHAFT (B) ASSEMBLY	
22-2	154452001	1	ク"ト"ーレハ"ー"イ"タ"ヒキハ"ネ	COIL SPRING	
31	154448001	1	ク"ト"ーレハ"ー"イ"タ	DRIVE LEVER PLATE	
32	154449001	2	ストツハ"ー	STOPPER	
33	025080232	2	ヒ"ラ"サ"カ"ネチユウ8	PLAIN WASHER 8	
34	028080242	2	ハ"ネ"サ"カ"ネ2-8	SPRING WASHER 2-8	
35	105812003	2	ナ"ツ"ト7.94	NUT 7.94	
36	017762012	2	ホ"ルト5.95X20	BOLT 5.95X20	
37	025060232	2	ヒ"ラ"サ"カ"ネチユウ6	PLAIN WASHER 6	
38	150553001	2	ナ"ツ"ト5.95	NUT 5.95	

H. 下軸関係 / Lower shaft mechanism / Untere Welle /
 Mécanisme de l'arbre inférieur / Mecanismo del eje inferior

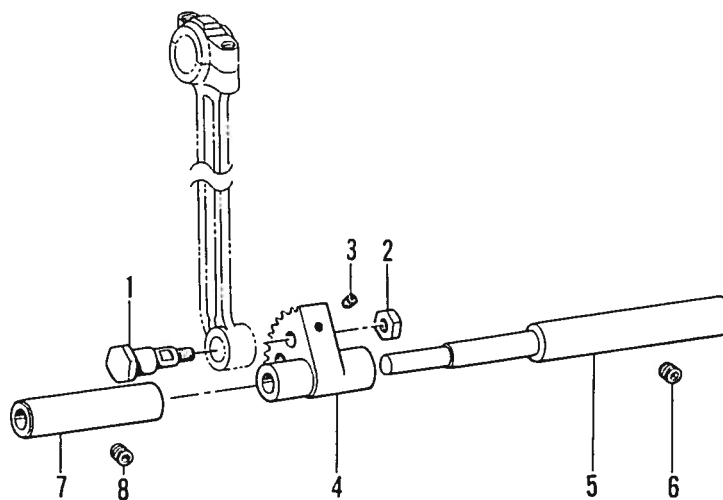
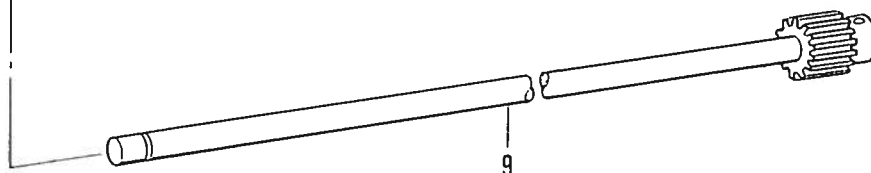
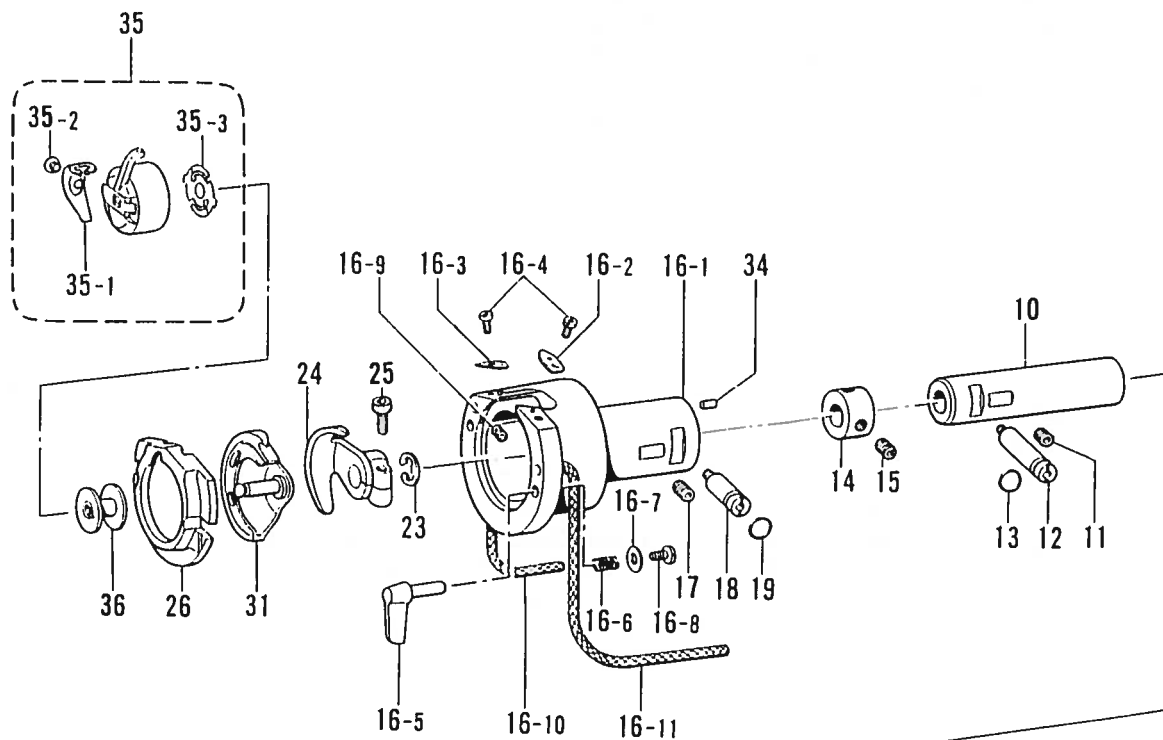

H. 下軸関係 / Lower shaft mechanism / Untere Welle /
Mécanisme de l'arbre inférieur / Mecanismo del eje inferior

REF.NO.	CODE	Q'TY	ヒンメイ	NAME OF PARTS	RMKS
1	141786001	1	クランクロッド"ダ"ンネジ"	CRANK ROD STUD SCREW	
2	104689002	1	ナット7.14	NUT 7.14	
3	014680622	1	アナトメネジ"4.37クホ"ミ	SET SCREW 4.37	
4	152245001	1	ヨウト"ウキ"ヤ	ROCK GEAR	
5	152246001	1	ヨウト"ウキ"ヤーシ"ク	ROCK GEAR SHAFT	
6	014760622	1	アナトメネジ"5.95	SET SCREW 5.95	
7	152247001	1	ヨウト"ウジ"クメタル	ROCK SHAFT BUSH	
8	014760622	1	アナトメネジ"5.95	SET SCREW 5.95	
9	152191101	1	シタシ"ククミ	LOWER SHAFT ASSEMBLY	
10	152250001	1	シタシ"クメタル	LOWER SHAFT BUSH	
11	014760622	1	アナトメネジ"5.95	SET SCREW 5.95	
12	152678001	1	カマチヨウセツシ"ク	SHUTTLE HOOK ADJUST STUD	
13	081003670	1	Oリング"PW3	O RING PW3	
14	110495003	1	セツトカラー	SET COLLAR	
15	014770622	2	アナトメネジ"6.35クホ"ミ	SET SCREW 6.35	
16	S00327001	1	オオカマタイクミ	LARGE SHUTTLE HOOK BASE ASSEMBLY	
16-1	152677001	1	オオカマタイ	LARGE SHUTTLE HOOK BODY	
16-2	152679001	1	カマイトアンナイR	SHUTTLE RACE THREAD GUIDE (R)	
16-3	152680001	1	カマイトアンナイL	SHUTTLE RACE THREAD GUIDE (L)	
16-4	062660412	2	ナヘ"コ318-40X4	SCREW 318X4	
16-5	152683001	2	オオカマトリツケツメ	LARGE SHUTTLE HOOK SET CLAW	
16-6	152684001	2	オオカマトリツケハ"ネ	LARGE SHUTTLE HOOK SET SPRING	
16-7	402887001	2	サ"ガ"ネ3.2	WASHER 3.2	
16-8	062660712	2	ナヘ"コ318-40X7	SCREW 318X7	
16-9	153050000	2	オオカマタイプフェルト	LARGE SHUTTLE HOOK BASE FELT	
16-10	155489000	1	クミヒモ(27CM)	WICK(27CM)	
16-11	S00400000	1	クミヒモ2.5X220	WICK 2.5X220(22CM)	
17	014760622	1	アナトメネジ"5.95	SET SCREW 5.95	
18	152678001	1	カマチヨウセツシ"ク	SHUTTLE HOOK ADJUST STUD	
19	081003670	1	Oリング"PW3	O RING PW3	
23	048080342	1	トメワE8	STOP RING E8	
24	152681201	1	ト"ライハ"ー	DRIVER	
25	018501422	1	アナボ"ルト5X14	BOLT 5X14	
26	152682001	1	オオカマA	LARGE SHUTTLE HOOK (A)	
31	152685101	1	ナカカマA	INNER ROTARY HOOK (A)	
34	141808001	1	オオカマアンナイピン	PIN	
35	159610101	1	ホ"ビ"ンケースクミA	BOBBIN CASE ASSEMBLY (A)	
35-1	154339001	1	ホ"ビ"ンケースショウシハ"ネ	BOBBIN CASE TENSION SPRING	
35-2	154341001	1	ホ"ビ"ンケースハ"ネネジ"	ADJUSTING SCREW	
35-3	159612001	1	クウテンホ"ウシハ"ネ	BOBBIN TENSION SPRING	
36	159613001	1	ホ"ビ"ン	BOBBIN	

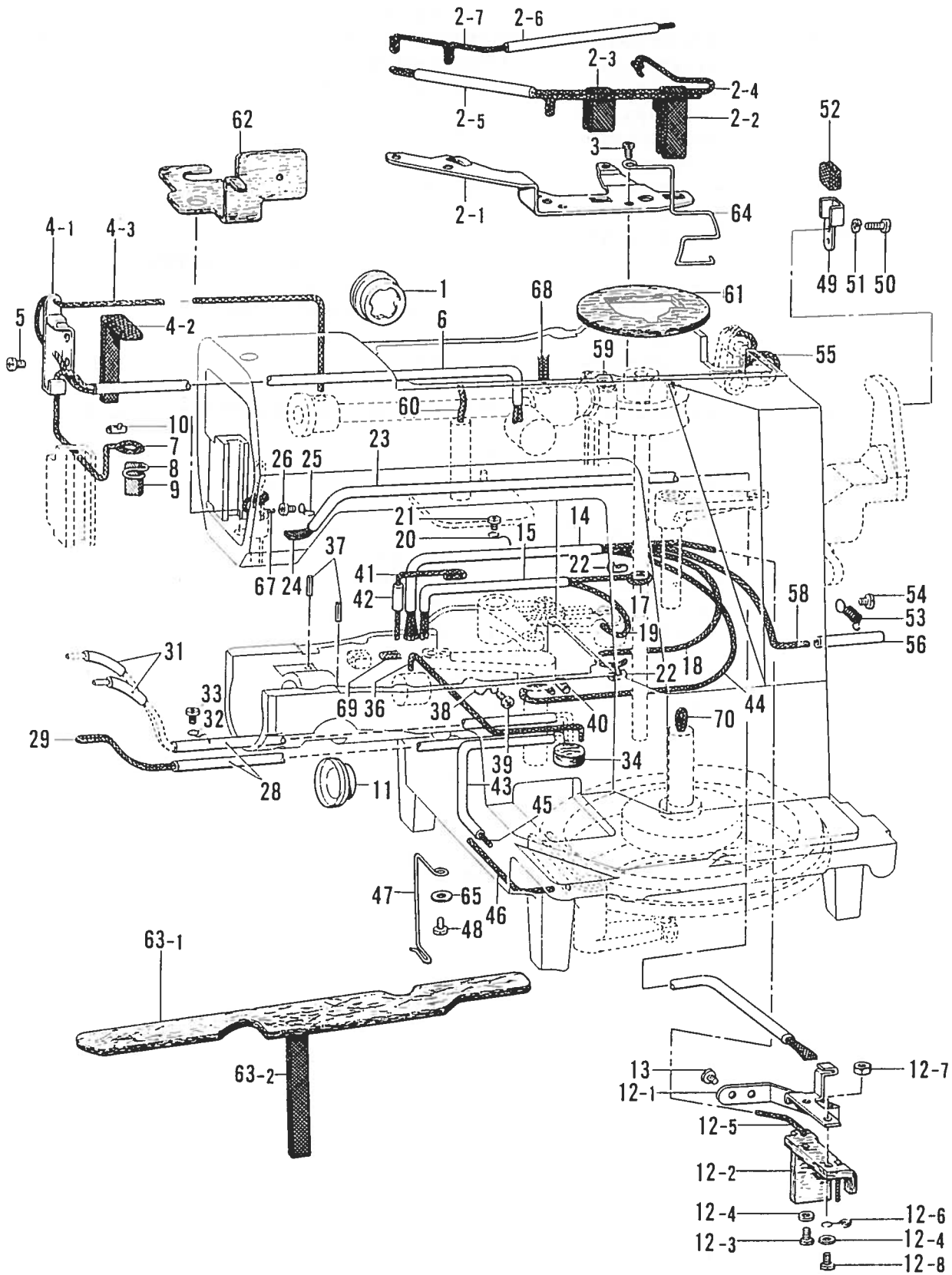

J. 給油潤滑関係 / Lubrication / Schmierung / Lubrification / Lubricación

REF.NO.	CODE	Q'TY	ヒンメイ	NAME OF PARTS	RMKS
1	152948001	1	オイルホ"ツトマト"	OIL GAUGE WINDOW	
2	152949001	1	ウフジ"クキユウユササエクミ	WICK SUPPORT ASSEMBLY	
2-1	152950001	1	ウフジ"クキユウユササエ	WICK SUPPORT	
2-2	152951001	1	ウオムキユウユフエルト	FELT	
2-3	152952001	1	ロツト"キユウユフエルト	FELT	
2-4	153918001	1	クミヒモ6X6 (66CM)	WICK 6X6 (66CM)	
2-5	140423000	1	ヒ"ニルチューブ"	OIL TUBE	
2-6	147745000	1	ハイユハ"イフ" L	OIL TUBE (L)	
2-7	153919001	1	クミヒモ6X6 (37CM)	WICK 6X6 (37CM)	
3	062681012	2	ナヘ"コ437-40X10	SCREW 437X10	
4	152958001	1	デンヒ"ンキユウユササエクミ	WICK SUPPORT ASSEMBLY	
4-1	152959001	1	デンヒ"ンキユウユササエ	WICK SUPPORT	
4-2	152955001	1	ヒラクミヒモ (21CM)	FLAT WICK(21CM)	
4-3	152956001	1	クミヒモ4X4 (50CM)	WICK 4X4 (50CM)	
5	062680612	1	ナヘ"コ4.37-40X6	SCREW 437X6	
6	144694001	1	ハイユハ"イフ"	OIL TUBE	
7	152956001	1	クミヒモ4X4 (50CM)	WICK 4X4 (50CM)	
8	152962001	1	ハリホ"ウメタルヒモササエ	WICK SUPPORT	
9	152960001	1	ヒラクミヒモ (4CM)	FLAT WICK (4CM)	
10	104567001	1	クミヒモササエ	WICK SUPPORT	
11	152948001	1	オイルホ"ツトマト"	OIL GAUGE WINDOW	
12	152961001	1	シタジ"クキユウユササエクミ	FELT SUPPORT ASSEMBLY	
12-1	152966001	1	シタジ"クキユウユササエ	FELT SUPPORT	
12-2	152967001	1	シタジ"クキユウユフエルト	FELT	
12-3	062670812	2	ナヘ"コ357-40X8	SCREW 357X8	
12-4	025350332	3	ヒラサ"ガ"ネタ"イ3.5	PLAIN WASHER 3.5	
12-5	152963001	1	クミヒモ4X4 (60CM)	WICK 4X4 (60CM)	
12-6	141692001	1	ヒ"ニルチューブ"ササエC	OIL SUPPORT (C)	
12-7	021670202	1	ナツト2シユ3.57	NUT 3.57	
12-8	062671412	1	ナヘ"コ357-40X14	SCREW 357X14	
13	062670612	2	ナヘ"コ357-40X6	SCREW 357X6	
14	148921000	1	ヒ"ニルチューブ"	OIL TUBE	
15	147745000	1	ハイユハ"イフ" L	OIL TUBE (L)	
17	152964001	1	クミヒモ6X6 (31CM)	WICK 6X6 (31CM)	
18	152965001	1	クミヒモ4X4 (40CM)	WICK 4X4 (40CM)	
19	152964001	1	クミヒモ6X6 (31CM)	WICK 6X6 (31CM)	
20	152969001	1	コード"ササエカネ	CORD SUPPORT	
21	062670512	1	ナヘ"コ357-40X5	SCREW 357X5	
22	104567001	2	クミヒモササエ	WICK SUPPORT	
23	146375000	1	ヒ"ニルチューブ"	OIL TUBE	
24	152992001	1	ヒラクミヒモ (76CM)	FLAT WICK (76CM)	
25	117150001	1	コード"ササエカネ	CORD SUPPORT	
26	062670512	1	ナヘ"コ357-40X5	SCREW 357X5	
28	140423000	2	ヒ"ニルチューブ"	OIL TUBE	
29	152971001	1	クミヒモ4X4 (48CM)	WICK 4X4 (48CM)	
31	112669001	2	ヒ"ニルチューブ"	OIL TUBE	
32	152969001	1	コード"ササエカネ	CORD SUPPORT	
33	062670512	1	ナヘ"コ357-40X5	SCREW 357X5	
34	113006001	1	フェルト	FELT	
36	152973001	1	クミヒモ4X4 (17CM)	WICK 4X4 (17CM)	
37	047251640	2	スプリング"ピンAW2.5	SPRING PIN AW2.5	
38	117150001	1	コード"ササエカネ	CORD SUPPORT	
39	062670512	1	ナヘ"コ357-40X5	SCREW 357X5	
40	104567001	1	クミヒモササエ	WICK SUPPORT	
41	152974001	1	クミヒモ4X4 (35CM)	WICK 4X4 (35CM)	
42	112669001	1	ヒ"ニルチューブ"	OIL TUBE	
43	147745000	1	ハイユハ"イフ" L	OIL TUBE (L)	
44	153922001	1	クミヒモ4X4 (50CM)	WICK 4X4 (50CM)	
45	152953001	1	クミヒモ6X6 (36CM)	WICK 6X6 (36CM)	
46	152985001	1	クミヒモ4X4 (12CM)	WICK 4X4 (12CM)	
47	153763001	1	キユウユヒモササエ	WICK SUPPORT	
48	062670512	1	ナヘ"コ357-40X5	SCREW 357X5	

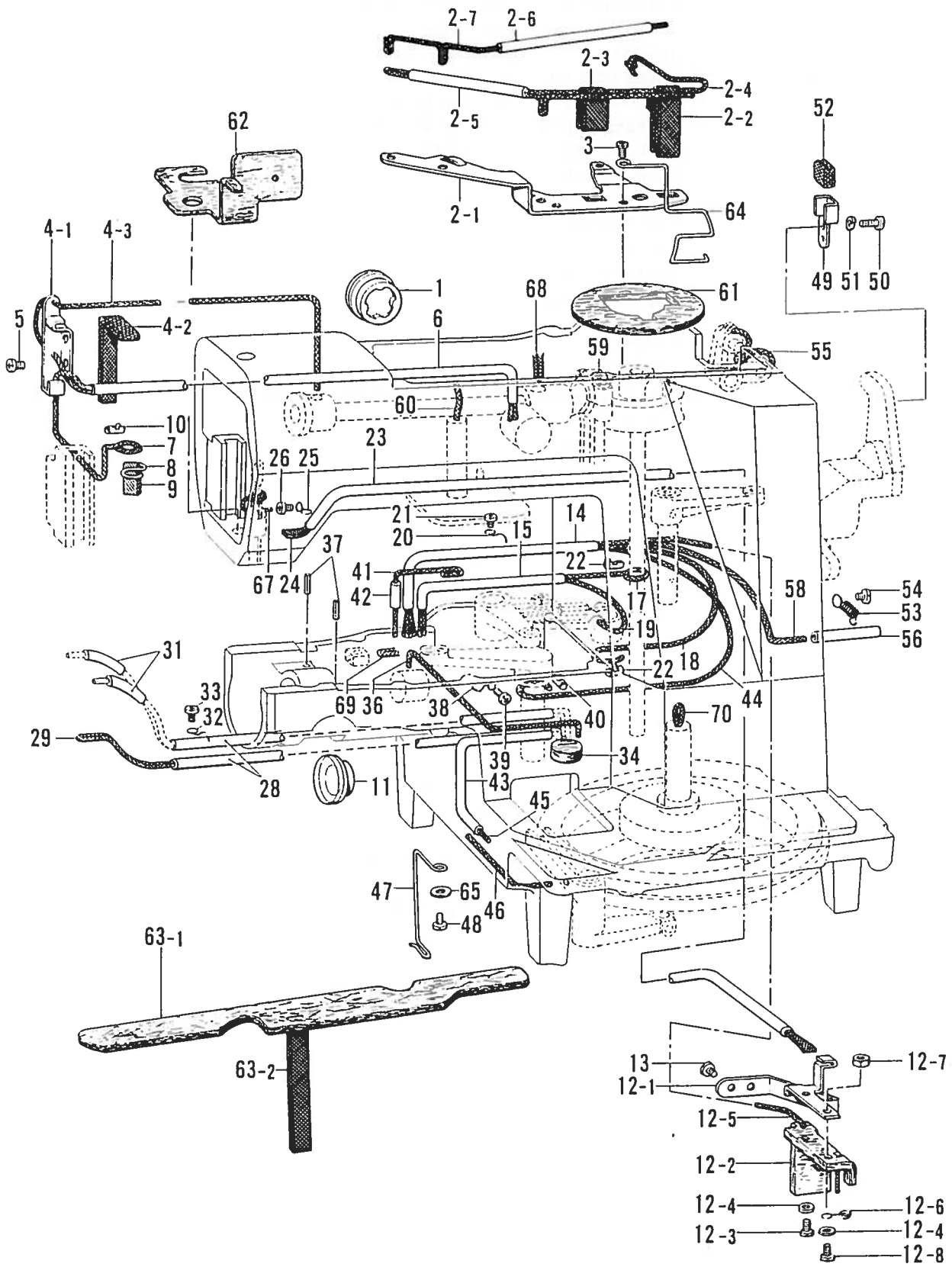

J. 給油潤滑関係 / Lubrication / Schmierung / Lubrification / Lubricación

REF.NO.	CODE	Q'TY	ヒンメイ	NAME OF PARTS	RMKS
49	152976001	1	ホールキユウユヒモササエ	WICK SUPPORT	
50	062670512	2	ナヘコ357-40X5	SCREW 357X5	
51	028040242	2	ハネサカガネ	SPRING WASHER	
52	152977001	1	ヒラクミヒモ (5CM)	WICK (5CM)	
53	152978001	1	チューブオサエ	TUBE SUPPORT	
54	062680812	1	ナヘコ437-40X8	SCREW 437X8	
55	153927001	1	クミヒモ6X6 (18CM)	WICK 6X6 (18CM)	
56	112669001	1	ヒニルチューブ	OIL TUBE	
58	153922001	1	クミヒモ4X4 (50CM)	WICK 4X4 (50CM)	
59	107149001	1	フェルト	FELT	
60	152968001	1	クミヒモ4X4 (10CM)	WICK 4X4 (10CM)	
61	153529101	1	ホイールキユウユフェルト	FELT	
62	153530001	1	スイアケフェルト	FELT	
63-1	153531001	1	ベットLフェルト	BED (L) FELT	
63-2	153562001	1	ヒラクミヒモ (15CM)	FLAT WICK (15CM)	
64	153528001	1	ウオームキユウユフェルトササエ	FELT SUPPORT	
65	105248003	1	サカガネ	WASHER	
67	152973001	1	クミヒモ4X4 (17CM)	WICK 4X4 (17CM)	
68	153925001	1	クミヒモ4X4 (3CM)	WICK 4X4 (3CM)	
69	153926001	1	タコヒモ (10CM)	WICK (10CM)	
70	152980001	1	クミヒモ6X6 (15CM)	WICK 6X6 (15CM)	

K. 糸通シ関係/Threading mechanism/Fadenführungs-vorrichtung/
Mécanisme de l'enfilage/Mecanismo del enhebrado

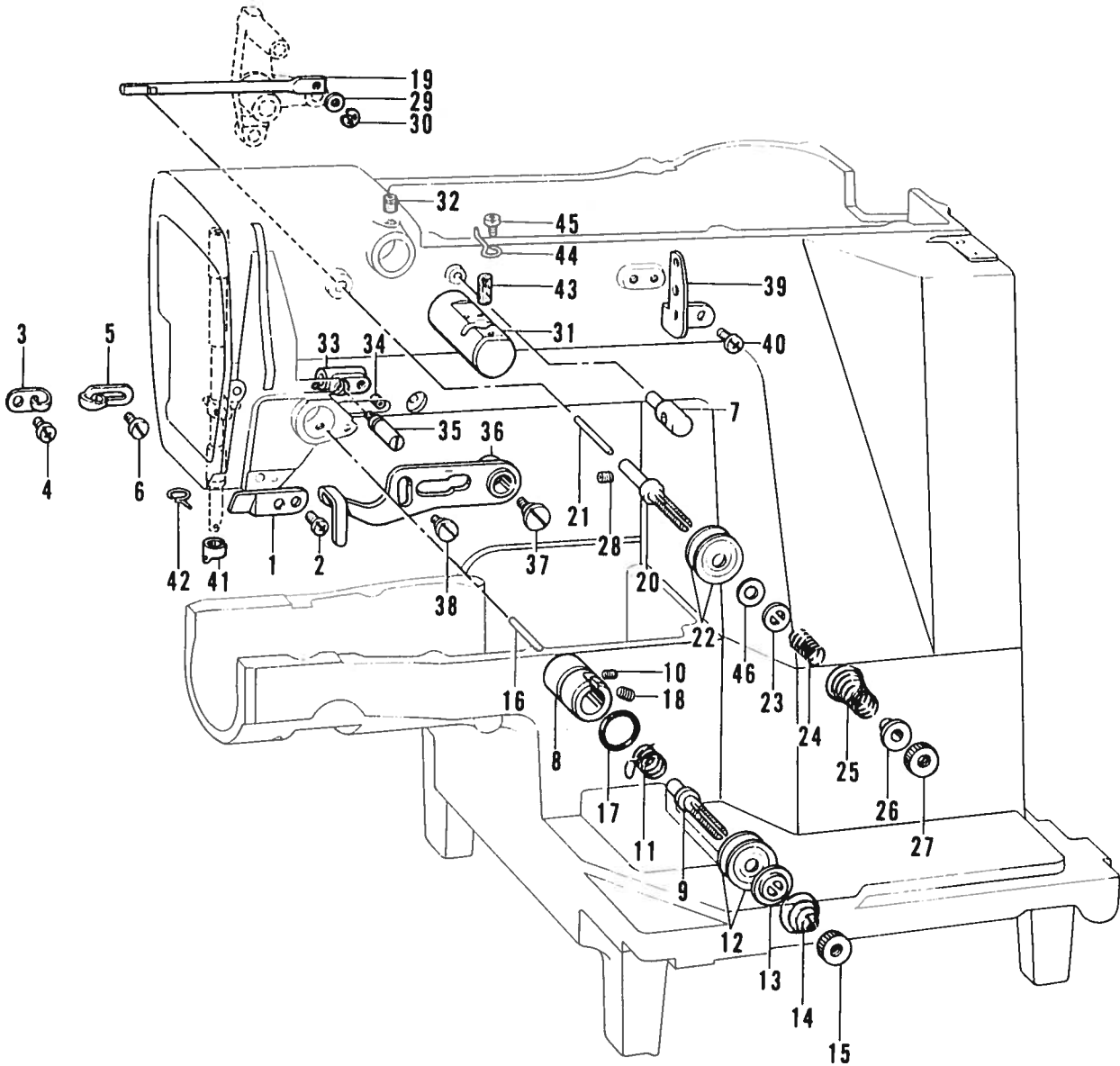

K. 糸通シ関係/Threading mechanism/Fadenführungsvorrichtung/
Mécanisme de l'enfilage/Mecanismo del enhebrado

REF.NO.	CODE	Q'TY	ヒンメイ	NAME OF PARTS	RMKS
1	152869001	1	アームイトミチ	ARM THREAD GUIDE	
2	062710712	1	ナヘ"コ476-32X7	SCREW 476X7	
3	152870001	1	アームイトカケ	ARM THREAD GUIDE	
4	062670612	1	ナヘ"コ357-40X6	SCREW 357X6	
5	113316001	1	アームイトアンナイ	ARM THREAD GUIDE	
6	112751003	1	シメネシ"3.57	SCREW 3.57	
7	153049001	1	ウワイトアンナイホ"ウ	UPPER THREAD GUIDE BAR	
8	152872001	1	イトチヨウシタイ	TENSION BRACKET	
9	100398001	1	イトチヨウシホ"ウ	TENSION STUD	
10	100402004	1	トメネシ"3.57	SET SCREW 3.57	
11	145519001	1	イトトリハ"ネ	THREAD TAKE-UP SPRING	
12	145446001	2	イトチヨウシサラ	TENSION DISC	
13	159805001	1	イトチヨウシサラオサエ	TENSION DISC PRESSER	
14	104525001	1	イトチヨウシハ"ネ	TENSION SPRING	
15	100136001	1	イトチヨウシナツト	TENSION NUT	
16	152873001	1	イトユルメヒン	TENSION RELEASE PIN	
17	114294001	1	Oリング"	O RING	
18	103950003	1	トメネシ"5.95	SET SCREW 5.95	
19	154424001	1	フクイトユルメホ"ウ431	SUB TENSION RELEASE BAR FOR B431	
20	152875001	1	フクイトチヨウシホ"ウ	SUB TENSION STUD	
21	152876001	1	フクイトユルメヒン	SUB TENSION RELEASE PIN	
22	145446001	2	イトチヨウシサラ	TENSION DISC	
23	152877001	1	イトチヨウシサラオサエ	TENSION DISC WASHER	
24	152878001	1	ウワイトオサエハ"ネ	UPPER THREAD SPRING	
25	152879101	1	フクチヨウシハ"ネ	SUB TENSION SPRING	
26	152880001	1	ハ"ネウケ	SPRING HOLDER	
27	100136001	1	イトチヨウシナツト	TENSION NUT	
28	014680422	1	アナトメネシ"4.37クホ"ミ	SET SCREW 4.37	
29	140208001	1	サ"ガ"ネ	WASHER	
30	048040342	1	トメフE4	STOP RING E4	
31	152881001	1	エキレイタイクミ	NEEDLE COOLER ASSEMBLY	
32	013760612	1	トメネシ"5.95クホ"ミ	SET SCREW 5.95	
33	152886001	1	イトリアンナイシ"クウケ	THREAD TAKE-UP GUIDE	
34	014680422	1	アナトメネシ"4.37クホ"ミ	SET SCREW 4.37	
35	152887001	1	イトリアンナイシ"ク	THREAD TAKE-UP LEVER GUIDE STUD	
36	152888101	1	イトトリレハ"-	THREAD TAKE-UP LEVER	
37	141528001	1	ダ"ンネシ"6.35	STUD SCREW 6.35	
38	115077003	1	ダ"ンネシ"4.76	STUD SCREW 4.76	
39	152889001	1	ミツメイトカケ	THREAD RETAINER	
40	062670612	2	ナヘ"コ357-40X6	SCREW 357X6	
41	152890001	1	ハリホ"ウワイトアンナイA	NEEDLE BAR THREAD GUIDE (A)	
42	152891001	1	ハリホ"ウメタルDイトアンナイ	NEEDLE BAR BUSH (D) THREAD GUIDE	
43	152883000	1	フェルト8X15.5	FELT 8X15.5	
44	152884001	1	エキレイイトカケ	NEEDLE COOLER THREAD GUIDE	
45	062670412	1	ナヘ"コ357-40X4	SCREW 357X4	
46	153138001	1	サ"ガ"ネ	WASHER	

L. 糸巻き関係 / Bobbin winder mechanism / Spuler /
 Mécanisme du bobineur / Mecanismo del devanador de la canilla

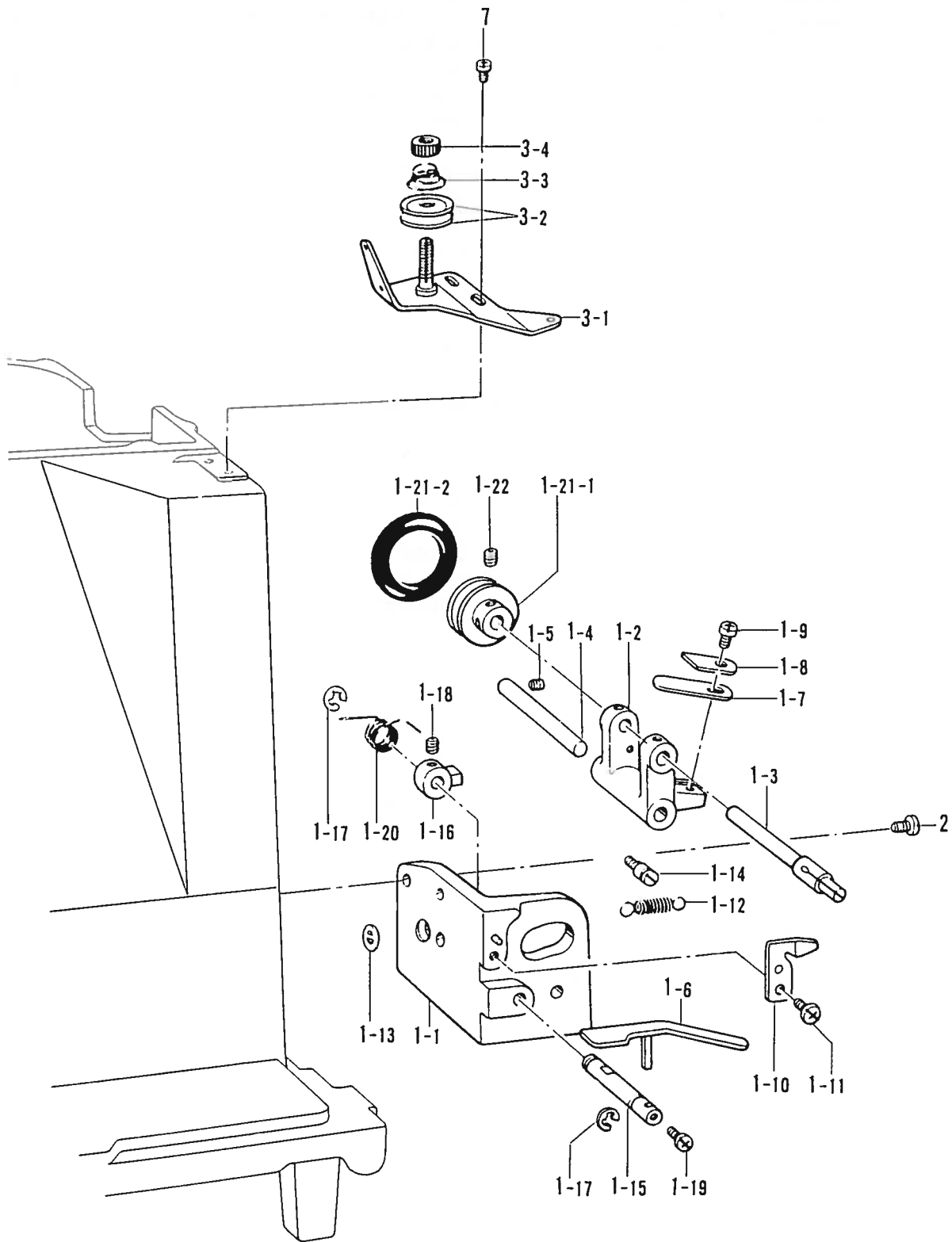

L. 糸巻キ関係/Bobbin winder mechanism/Spuler/
 Mécanisme du bobineur/Mecanismo del devanador de la canilla

REF NO.	CODE	Q'TY	ヒンメイ	NAME OF PARTS	RMKS
1	152982109	1	イトマキクミ	BOBBIN WINDER ASSEMBLY	
1-1	152983009	1	イトマキクイ	BOBBIN WINDER BRACKET	
1-2	152984001	1	イトマキレハ-	BOBBIN WINDER LEVER	
1-3	152933001	1	イトマキシク	BOBBIN WINDER SHAFT	
1-4	152934001	1	イトマキレハ-シク	BOBBIN WINDER LEVER SHAFT	
1-5	102716004	1	トメネシ"4.37	SET SCREW 4.37	
1-6	152935001	1	ホ"ヒンオサエ	BOBBIN PRESSER	
1-7	152936001	1	イタハ"ネ	PLATE SPRING	
1-8	152937001	1	サ"ガ"ネ	WASHER	
1-9	062670712	1	ナヘ"コ357-40X7	SCREW 357X7	
1-10	152938001	1	メス	KNIFE	
1-11	062680712	1	ナヘ"コ437-40X7	SCREW 437X7	
1-12	152939001	1	イトマキレハ-ヒキハ"ネ	COIL SPRING	
1-13	115138001	1	レハ"-ヒキハ"ネカケ	SPRING HOOK	
1-14	141550001	1	テイシレハ"-ハ"ネカケ	STOP LEVER SPRING HOOK	
1-15	152940001	1	イトマキツメシク	BOBBIN WINDER CLAW STUD	
1-16	142566001	1	イトマキツメ	BOBBIN WINDER CLAW	
1-17	048050342	2	トメフE5	STOP RING E5	
1-18	014680422	2	アトメネシ"4.37クホ"ミ	SET SCREW 4.37	
1-19	062670712	1	ナヘ"コ357-40X7	SCREW 357X7	
1-20	152941001	1	イトマキツメネシ"リハ"ネ	TWIST SPRING	
1-21-1	154528001	1	イトマキクルマ	BOBBIN WINDER WHEEL	
1-21-2	120448001	1	ゴムフ	RUBBER RING	
1-22	102716004	2	トメネシ"4.37	SET SCREW 4.37	
2	062761412	2	ナヘ"コ595-28X14	SCREW 595X14	
3	S01300009	1	シタイトチヨウシクミ	LOWER THREAD TENSION ASSEMBLY	
3-1	152945001	1	シタイトチヨウシクミ	LOWER THREAD TENSION BRACKET ASSEMBLY	
3-2	145446001	2	イトチヨウシサラ	TENSION DISC	
3-3	104525001	1	イトチヨウシハ"ネ	TENSION SPRING	
3-4	108265009	1	イトチヨウシナツト	TENSION NUT	
7	062681012	2	ナヘ"コ437-40X10	SCREW 437X10	

M. 糸切り関係 / Thread trimmer mechanism / Fadenabschneidevorrichtung /
 Mécanisme de coupe-fil / Mecanismo de la cortadura de hilos

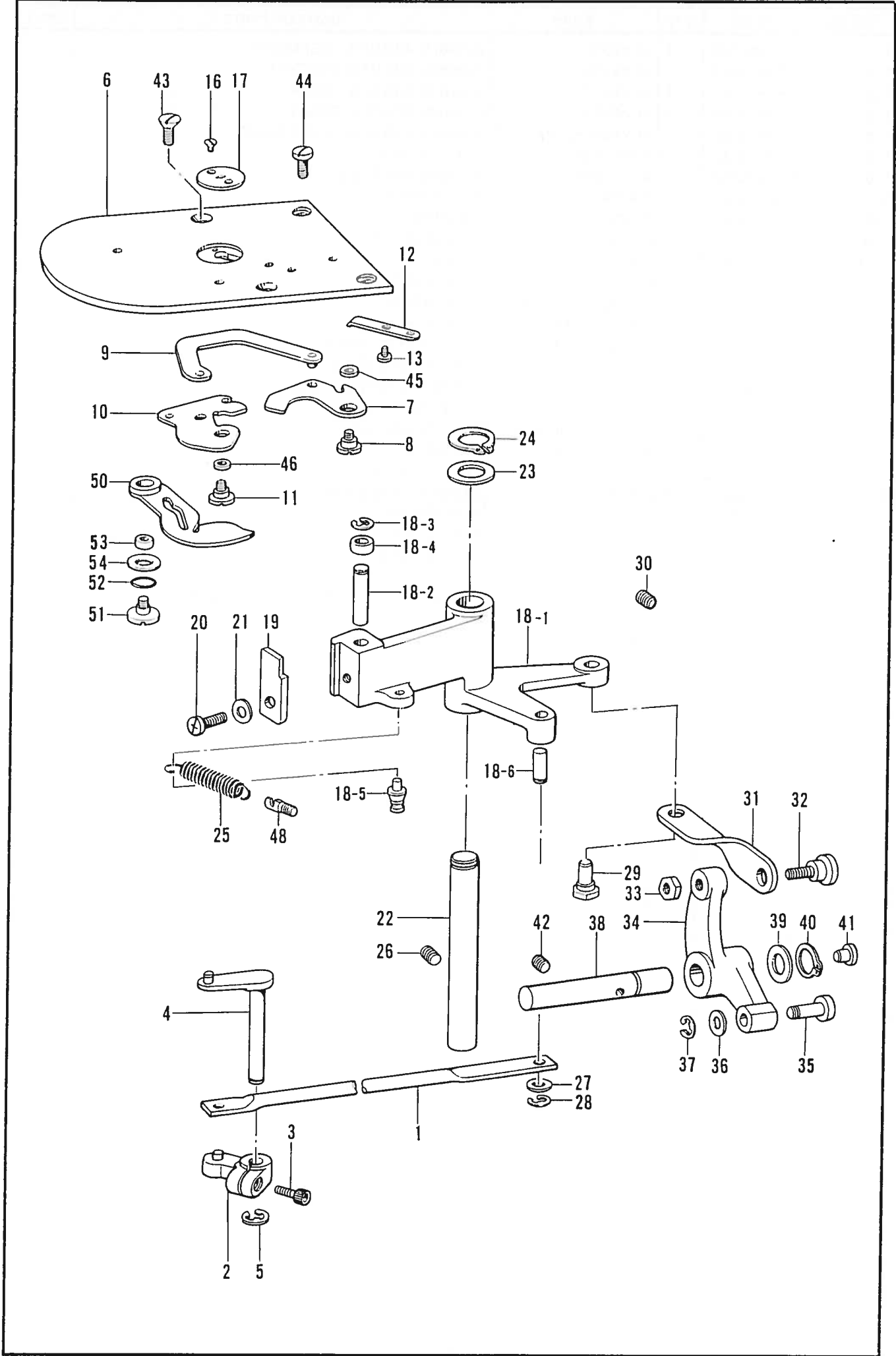

M. 糸切り関係/Thread trimmer mechanism/Fadenabschneidevorrichtung/
Mécanisme de coupe-fil/Mecanismo de la cortadura de hilos

REF.NO.	CODE	Q'TY	ヒンメイ	NAME OF PARTS	RMKS
1	152892001	1	イトキリレンケツロツト	THREAD TRIMMER CONNECTING ROD	
2	152896001	1	イトキリウテ"Aクミ	THREAD TRIMMER ARM ASSEMBLY (A)	
3	018681022	1	アナボ"ルト4.37X10	BOLT 4.37X10	
4	152893101	1	イトキリウテ"B	THREAD TRIMMER ARM (B)	
5	048050342	1	トメワE5	STOP RING E5	
6	152995001	1	ハリイタS	NEEDLE PLATE (S)	
7	152981001	1	イトキリウテ"C	KNIFE ARM (C)	
8	153222001	1	シメネシ"4.37	SCREW 4.37	
9	152897201	1	イトキリレンカンクミ	KNIFE CONNECTING ROD ASSEMBLY	
10	152901001	1	イト"ウハクミ	MOVABLE KNIFE ASSEMBLY	
11	152904001	1	シメネシ"4.37	SCREW 4.37	
12	152905001	1	コテイハ	FIXED KNIFE	
13	111140002	2	シメネシ"2.38	SCREW 2.38	
16	100360003	2	サラネシ"2.38	SCREW 2.38	
17	156150001	1	ハリアナイタB	NEEDLE HOLE PLATE (B)	
18-1	152912001	1	イトキリカムレハ"ー	THREAD TRIMMER CAM LEVER	
18-2	152913001	1	コロシ"ク	ROLLER SHAFT	
18-3	048040342	1	トメワE4	STOP RING E4	
18-4	152914001	1	コロ	ROLLER	
18-5	154789001	1	ハ"ネカケ	SPRING HOOK	
18-6	152919001	1	イトキリロツト"ヒ"ン	THREAD TRIMMER ROD PIN	
19	152915001	1	イトキリカムレハ"ーツメ	THREAD TRIMMER CAM LEVER CLAW	
20	062761412	1	ナヘ"コ595-28X14	SCREW 595X14	
21	025060132	1	ヒラサ"カ"ネシヨウ6	PLAIN WASHER 6	
22	152916001	1	イトキリカムレハ"ーシ"ク	THREAD TRIMMER CAM LEVER SHAFT	
23	152917001	1	サ"カ"ネ	WASHER	
24	048120142	1	トメワシ"クヨウC12	STOP RING C12	
25	154788001	1	イトキリカムレハ"ーハ"ネ	THREAD TRIMMER CAM LEVER SPRING	
26	014760622	1	アナトメネシ"5.95	SET SCREW 5.95	
27	140208001	1	サ"カ"ネ	WASHER	
28	048040342	1	トメワE4	STOP RING E4	
29	152920001	1	イトキリリンクチヨウセツシ"ク	STUD	
30	014760622	1	アナトメネシ"5.95	SET SCREW 5.95	
31	152921001	1	イトキリリンク	THREAD TRIMMER LINK	
32	151907001	1	タ"ンネシ"5.95	STUD SCREW 5.95	
33	150553001	1	ナツト5.95	NUT 5.95	
34	152922001	1	イトキリサト"ーレハ"ー	THREAD TRIMMER LEVER	
35	152923001	1	イトキリサト"ーレハ"ーコロ	THREAD TRIMMER ROLLER	
36	112468001	1	サ"カ"ネ	WASHER	
37	048050342	1	トメワE5	STOP RING E5	
38	153482001	1	イトキリサト"ーレハ"ーシ"ク	DRIVING SHAFT	
39	142628001	1	スイハイオクリクランクリンク"	FEED ROCK CRANK RING	
40	048110142	1	トメワシ"クヨウC11	STOP RING C11	
41	111865009	1	オイルメクラセン	OIL CAP	
42	014760622	1	アナトメネシ"5.95	SET SCREW 5.95	
43	100032004	2	サラネシ"4.37	SCREW 4.37	
44	153208002	2	シメネシ"4.37	SCREW 4.37	
45	153220001	1	イトキリウテ"Cカラー	KNIFE ARM (C) COLLAR	
46	153219001	1	イト"ウハカラー	MOVABLE KNIFE COLLAR	
48	141334001	1	ハ"ネカケ	SPRING HOOK	
50	152906101	1	シタイトサハ"キA	LOWER THREAD RETAINER (A)	
51	153598001	1	シメネシ"4.37	SCREW 4.37	
52	081008070	1	Oリング"P8	O RING P8	
53	153597001	1	シタイトサハ"キカラー	LOWER THREAD RETAINER COLLAR	
54	153596001	1	サ"カ"ネ	WASHER	

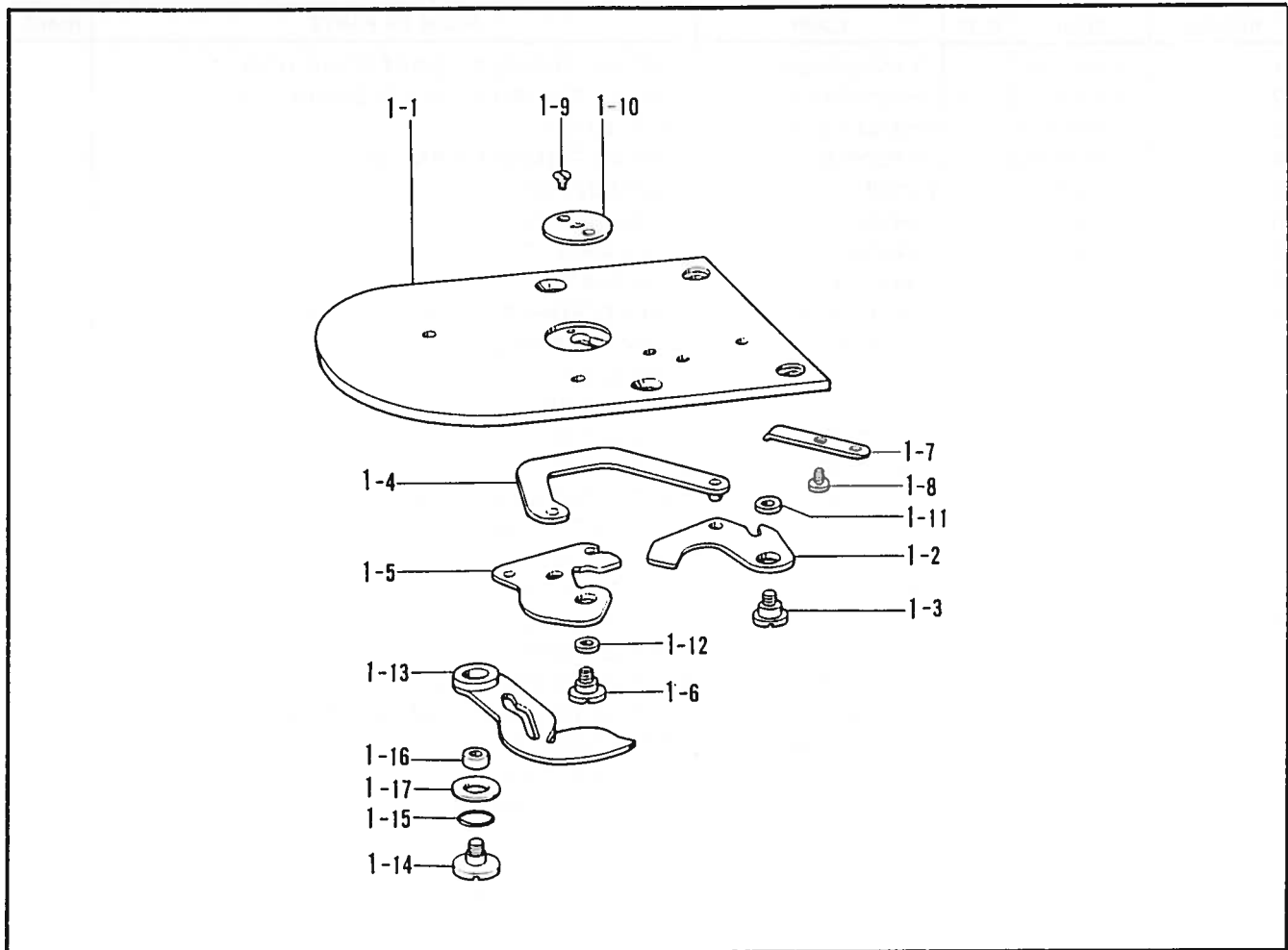

P. 動車・遊車関係 / Drive pulley and idler pulley mechanism / Antriebsriemenscheibe und Riemenscheibe / Mécanisme de poulie d'entraînement et poulie folle / Mecanismo de polea impulsora y polea tensora

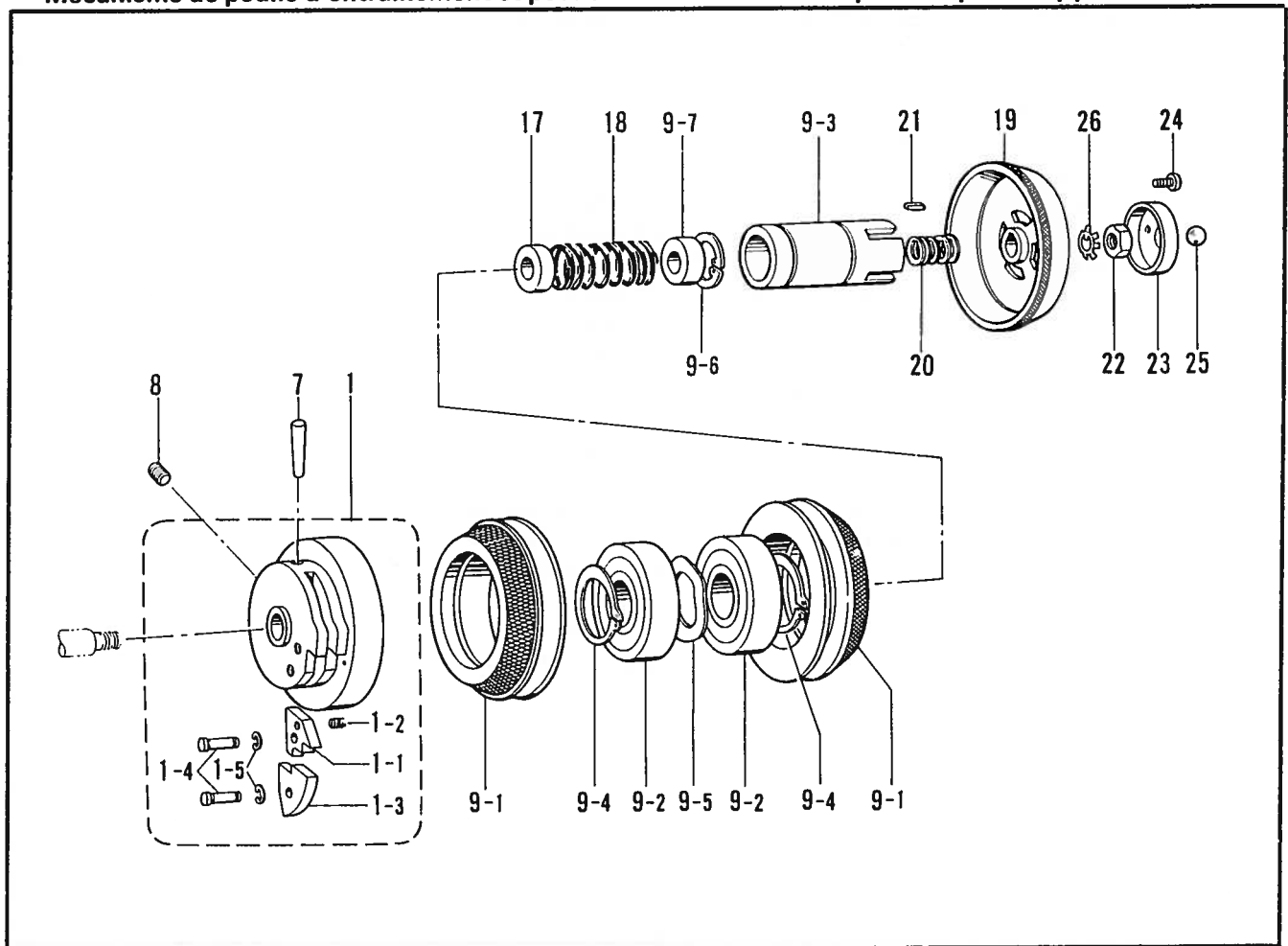

N. 特別注文部品/Option parts/Sonderzubehör/Pièces en option/Piezas opcionales

REF.NO.	CODE	Q'TY	ヒンメイ	NAME OF PARTS	RMKS
1	S18426001	1	ハリイタSクミ	NEEDLE PLATE (S) ASSEMBLY	
1-1	152995001	1	ハリイタS	NEEDLE PLATE (S)	
1-2	152981001	1	イトキリウテ"C	KNIFE ARM (C)	
1-3	153222001	1	シメネシ"4.37	SCREW 4.37	
1-4	152897201	1	イトキリレンカンクミ	KNIFE CONNECTING ROD ASSEMBLY	
1-5	152901001	1	イト"ウハクミ	MOVABLE KNIFE ASSEMBLY	
1-6	152904001	1	シメネシ"4.37	SCREW 4.37	
1-7	152905001	1	コテイハ	FIXED KNIFE	
1-8	111140002	2	シメネシ"2.38	SCREW 2.38	
1-9	100360003	2	サラネシ"2.38	SCREW 2.38	
1-10	156150001	1	ハリアナイタB	NEEDLE HOLE PLATE (B)	
1-11	153220001	1	イトキリウテ"Cカラー	KNIFE ARM (C) COLLAR	
1-12	153219001	1	イト"ウハカラー	MOVABLE KNIFE COLLAR	
1-13	152906101	1	シタイトサハ"キA	LOWER THREAD RETAINER (A)	
1-14	153598001	1	シメネシ"4.37	SCREW 4.37	
1-15	081008070	1	Oリング"P8	O RING P8	
1-16	153597001	1	シタイトサハ"キカラー	LOWER THREAD RETAINER COLLAR	
1-17	153596001	1	サ"カ"ネ	WASHER	

P. 動車・遊車関係 / Drive pulley and idler pulley mechanism / Antriebsriemenscheibe und Riemenscheibe / Mécanisme de poulie d'entraînement et poulie folle / Mecanismo de polea impulsora y polea tensora

REF.NO.	CODE	Q'TY	ヒンメイ	NAME OF PARTS	RMKS
1	153044001	1	ストップカムクミ	STOP CAM ASSEMBLY	
1-1	152693001	1	セイト"ウカムヘン	BRAKE CAM SEGMENT	
1-2	152694001	1	セイト"ウカムヘンハ"ネ	BRAKE CAM SEGMENT SPRING	
1-3	115003001	1	カンシヨウカムヘン	FLANGE CAM SEGMENT	
1-4	153058001	2	カムヘンジ"ク	CAM SEGMENT STUD	
1-5	048040342	2	トメワE4	STOP RING E4	
7	147111001	1	テーハ°ピン6X35	TAPER PIN 6X35	
8	014770622	1	アナトメネシ"6.35クホ"ミ	SET SCREW 6.35	
9	183686001	2	プーリオオクミ	PULLEY ASSEMBLY	
9-1	152695201	2	プーリクミ	PULLEY DEVICE ASSEMBLY	
9-2	072600760	2	タマシ"クウケ6007VV	BALL BEARING 6007VV	
9-3	152698001	1	スライト"メタル	SLIDE BUSH	
9-4	048350142	2	トメワシ"クヨウC35	STOP RING C35	
9-5	152699001	1	ナミワツシヤ	WASHER	
9-6	048240242	1	トメワアナヨウ C24	STOP RING C24	
9-7	152700000	1	スライト"フ"ツシユA	SLIDE BUSH (A)	
17	151946000	1	スライト"フ"ツシユB	SLIDE BUSH (B)	
18	152701001	1	クラツチハ"ンハ"ネ	CLUTCH PLATE SPRING	
19	152702001	1	クラツチハ"ン	CLUTCH PLATE	
20	152703100	5	スヘーサ	SPACER	
21	S02878000	1	ヘイコウキ3X3X13	KEY 3X3X13	
22	152705101	1	ナツト10ヒタ"リ	NUT 10	
23	152706001	1	ホ"ールウケ	BALL BEARING	
24	062660712	4	ナヘ"コ318-40X7	SCREW 318X7	
25	071095250	1	コウキユウ3/8	STEEL BALL 3/8	
26	S21120001	1	サ"カ"ネ	WASHER	

Q. 糸払い関係 / Thread wiper mechanism / Fadenwischvorrichtung /
 Mécanisme de tire-fil / Mecanismo del limpiador de hilo

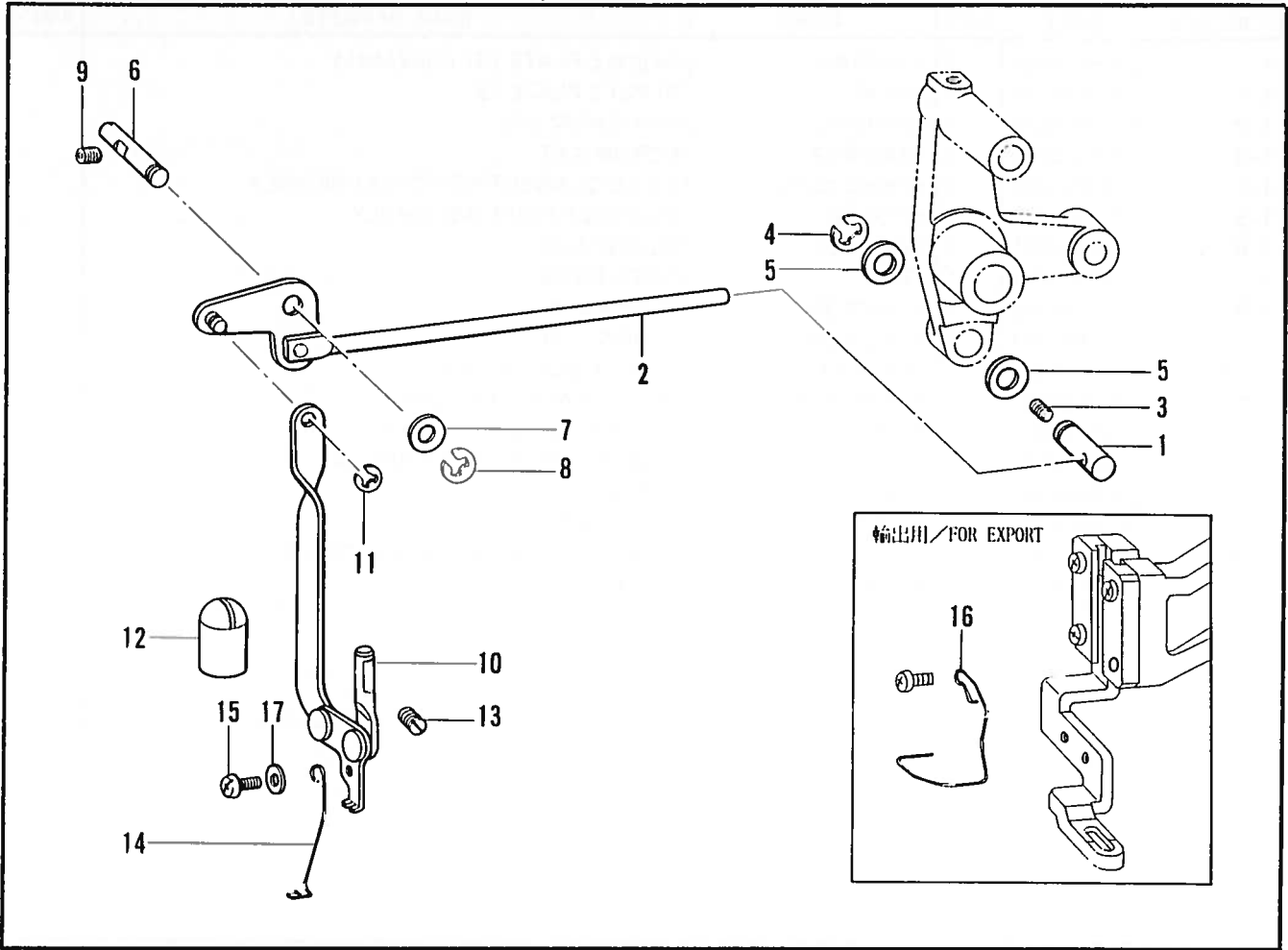

R. 糸締×関係 / Thread nipper mechanism / Fadenspannvorrichtung /
 Mécanisme de pince-fil / Mecanismo de la mordaza para hilo

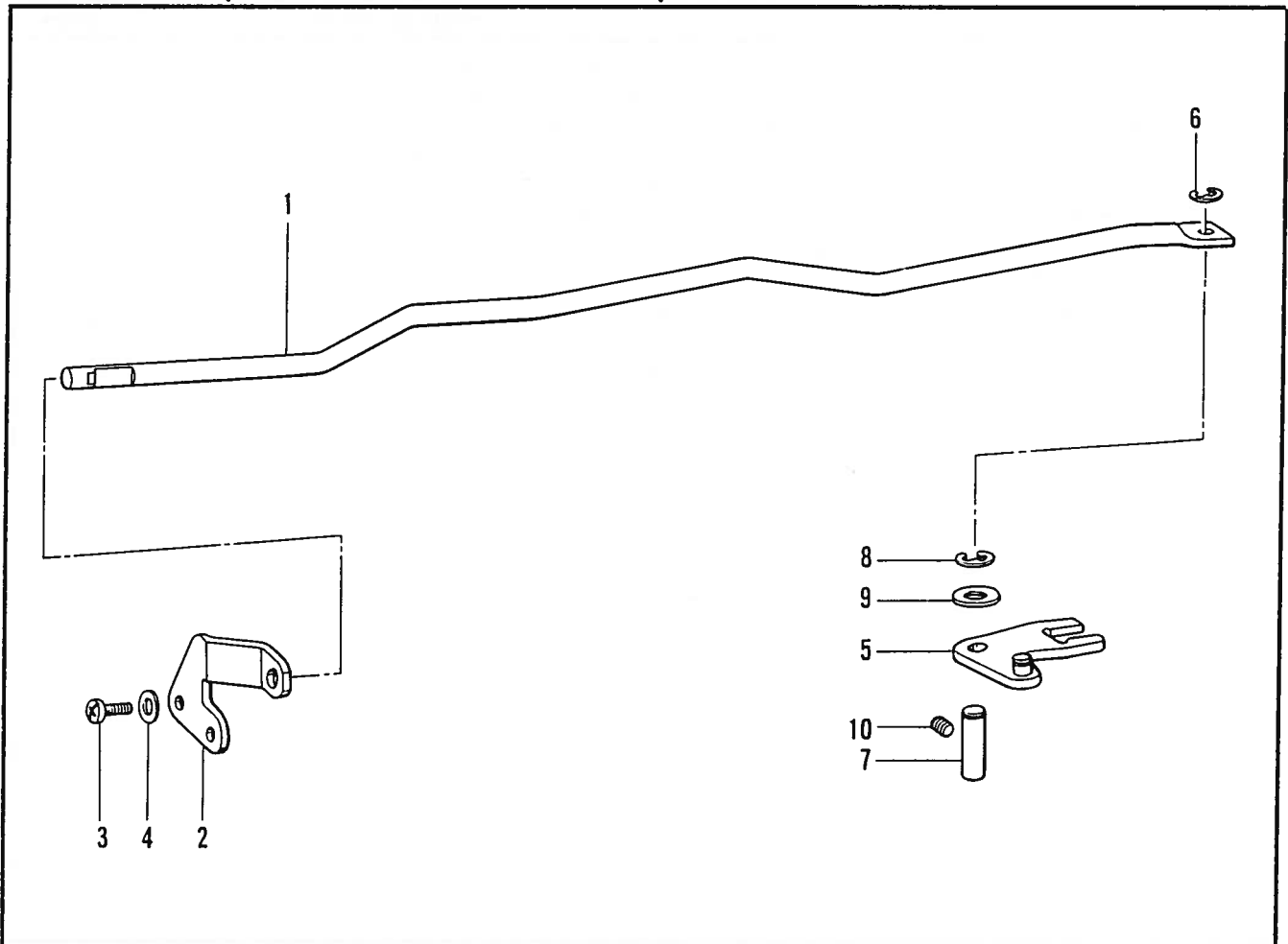

Q. 糸払い関係/Thread wiper mechanism/Fadenwischvorrichtung/
Mécanisme de tire-fil/Mecanismo del limpiador de hilo

REF.NO.	CODE	Q'TY	ヒンメイ	NAME OF PARTS	RMKS
1	152815001	1	ワイパ°-ロツト"シ"ク	THREAD WIPER ROD SHAFT	
2	152816001	1	ワイパ°-ロツト"クミ	THREAD WIPER ROD ASSEMBLY	
3	014680622	1	アナトメネシ"4.37クホ"ミ	SET SCREW 4.37	
4	048060342	1	トメフE6	STOP RING E6	
5	116629001	2	サ"カ"ネ	WASHER	
6	152822001	1	ワイパ°-シ"ク	THREAD WIPER SHAFT	
7	025770232	1	ヒラサ"カ"ネチユウ6.35	PLAIN WASHER 6.35	
8	048040342	1	トメフE4	STOP RING E4	
9	014680622	1	アナトメネシ"4.37クホ"ミ	SET SCREW 4.37	
10	152823001	1	ワイパ°-ウデ"クミ	THREAD WIPER ARM ASSEMBLY	
11	048030342	1	トメフE3	STOP RING E3	
12	152827009	1	オイルキリセン	OIL CAP	
13	013710712	1	トメネシ"4.76クホ"ミ	SET SCREW 4.76	
14	*	1	ワイパ°-B	-----	
15	062670512	1	ナヘ"コ357-40X5	SCREW 357X5	
16	*	1	-----	FINGER GUARD	
17	025350132	1	ヒラサ"カ"ネシヨウ	PLAIN WASHER	

R. 糸締メ関係/Thread nipper mechanism/Fadenspannvorrichtung/
Mécanisme de pince-fil/Mecanismo de la mordaza para hilo

REF.NO.	CODE	Q'TY	ヒンメイ	NAME OF PARTS	RMKS
1	152925101	1	ウワイトユルメホ"ウ	UPPER THREAD RELEASE SHAFT	
2	152926001	1	ユルメホ"ウササエイタ	TENSION RELEASE BAR PLATE	
3	062671012	2	ナヘ"コ357-40X10	SCREW 357X10	
4	025350332	2	ヒラサ"カ"ネタ"イ3.5	PLAIN WASHER 3.5	
5	152988001	1	ウワイトユルメレハ"ークミ	UPPER THREAD RELEASE LEVER ASSEMBLY	
6	048040342	1	トメフE4	STOP RING E4	
7	152929001	1	ウワイトユルメレハ"ーシ"ク	UPPER TENSION RELEASE LEVER SHAFT	
8	048050342	1	トメフE5	STOP RING E5	
9	025770232	1	ヒラサ"カ"ネチユウ6.35	PLAIN WASHER 6.35	
10	014760622	1	アナトメネシ"5.95	SET SCREW 5.95	

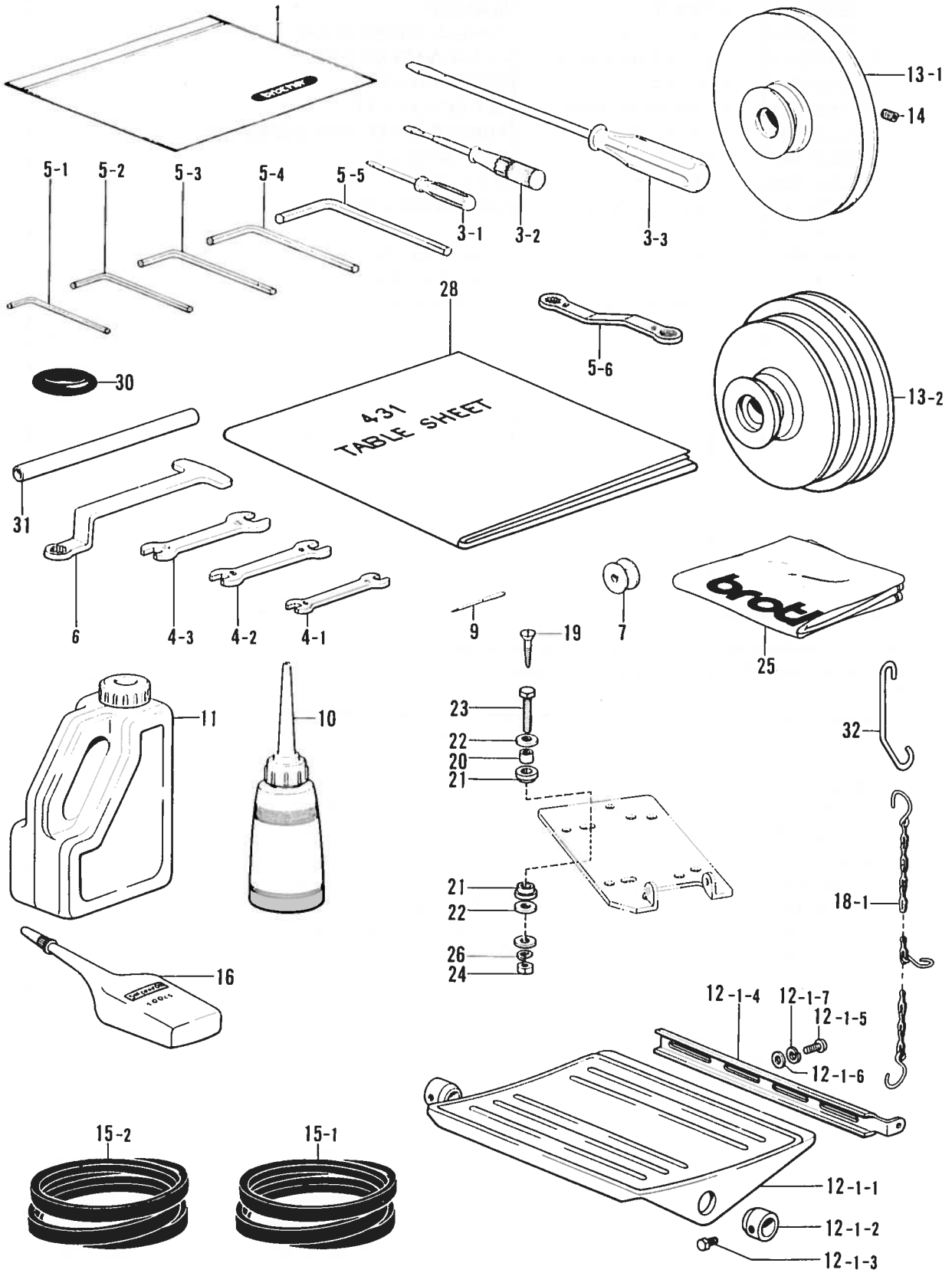

◎ 付属品の明細は変更することがあります。

◎ The details of included accessories are subject to change.

◎ Änderungen in der Aufstellung der Mitgelieferten Zubehöre sind vorbehalten.

◎ Les détails des accessoires inclus sont sujets à des changements.

◎ Los detalles de los accesorios incluidos pueden variar.

Z1. 付属品関係 / Accessories / Zubehör / Accessoires / Accessorios

REF.NO.	CODE	Q'TY	ヒンメイ	NAME OF PARTS	RMKS
1	122991001	1	フジ"クヒンホ"リフクロ	ACCESSORY BAG	
3-1	142443001	1	ネジ"マワシ1.9X52	SCREW DRIVER 1.9X52	
3-2	118837001	1	ネジ"マワシ3.4X70	SCREW DRIVER 3.4X70	
3-3	101572101	1	ネジ"マワシ5.5X190	SCREW DRIVER 5.5X190	
4-1	107779001	1	スハ"ナ6X7	SPANNER 6X7	
4-2	100887001	1	スハ"ナ8X9	SPANNER 8X9	
4-3	107780001	1	スハ"ナ10X12	SPANNER 10X12	
5-1	142002001	1	6カクホ"ウスハ"ナ2	HEXAGONAL WRENCH 2	
5-2	142721001	1	6カクホ"ウスハ"ナ3	HEXAGONAL WRENCH 3	
5-3	118064001	1	6カクホ"ウスハ"ナ4	HEXAGONAL WRENCH 4	
5-4	150335001	1	6カクホ"ウスハ"ナ5	HEXAGONAL WRENCH 5	
5-5	115157001	1	6カクホ"ウスハ"ナ6	HEXAGONAL WRENCH 6	
5-6	105343001	1	メカ"ネレンチ8X9	WRENCH 8X9	
6	152765001	1	メカ"ネレンチ10	WRENCH 10	
7	159613001	4	ホ"ヒ"ン	BOBBIN	
9	107415016	4	ミシンハリDPX5 (#16)	NEEDLE DPX5 (#16)	
10	114483002	1	ホ"リオイラー"クミ	OILER ASSEMBLY	
11	154702001	1	オイルタンク	OIL TANK	
12-1	154409009	1	ペ"タルクミ	PEDAL ASSEMBLY	
12-1-1	133636009	1	フミイタ	TREADLE	
12-1-2	116692009	2	フミイタイト"ウト"メ	TREADLE STOPPER	
12-1-3	017760812	2	ボ"ルト5.95X8	BOLT 5.95X8	
12-1-4	119709003	1	レンカントリツケウテ"	CONNECTING ROD SET ARM	
12-1-5	062061606	2	ナ"コ6X16	SCREW 6X16	
12-1-6	025060232	2	ヒラサ"カ"ネチユウ6	PLAIN WASHER 6	
12-1-7	028060242	2	ハ"ネサ"カ"ネ2-6	SPRING WASHER 2-6	
13-1	*	1	モーター"プーリ	MOTOR PULLEY	
13-2	*	1	モーター"プーリ	MOTOR PULLEY	
14	014760622	2	ア"ナトメネシ"5.95	SET SCREW 5.95	
15-1	082104891	1	V"ベルトM48	V-BELT M48	
15-2	*	1	V"ベルトM	V-BELT M	
16	S06706001	1	シリコンオイル	SILICONE OIL	
18-1	154427001	1	クサリクミ	CHAIN ASSEMBLY	
19	106030001	4	サラモクネシ"6.2X32	SCREW 6.2X32	
20	152863001	4	クツシヨンカラー	CUSHION COLLAR	
21	152864000	8	クツシヨン	CUSHION	
22	025800332	12	ヒラサ"カ"ネタ"イ7.14	PLAIN WASHER 7.14	
23	017062503	4	6カクボ"ルト6X25	BOLT 6X25	
24	021060102	4	ナツト1シユ6	NUT 6	
25	144226001	1	-----	HEAD COVER	
26	028060242	4	ハ"ネサ"カ"ネ2-6	SPRING WASHER 2-6	
28	154425001	1	テー"ブルシート431	TABLE SHEET FOR B431	
30	120448001	1	ゴ"ムワ	RUBBER RING	
31	154760001	1	ホ"ウスハ"ナハ"イフ"	PIPE	
32	154426001	1	クサリカケロツト	CHAIN HANGER ROD	

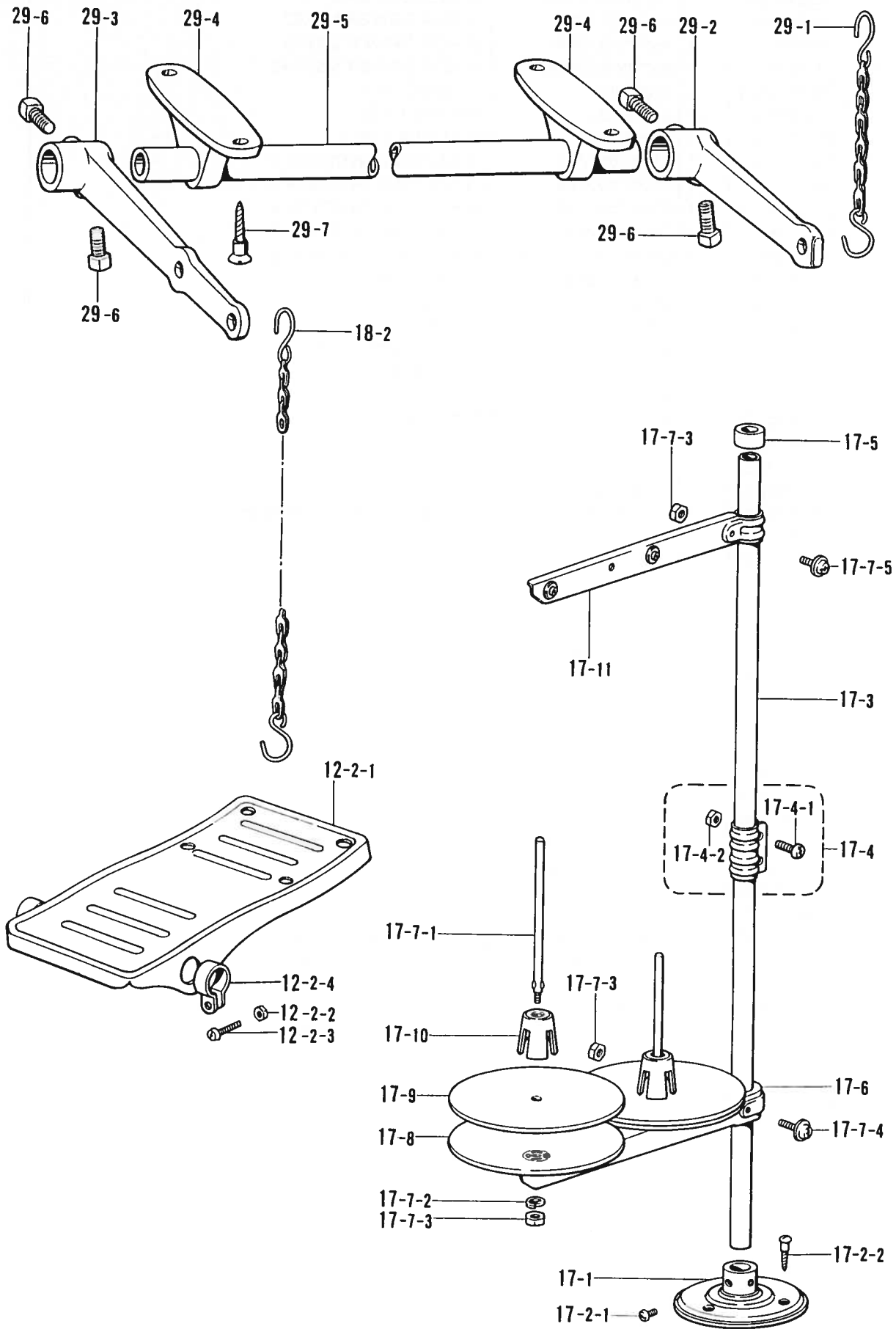

◎ 付属品の明細は変更することがあります。

◎ The details of included accessories are subject to change.

◎ Änderungen in der Aufstellung der Mitgelieferten Zubehöre sind vorbehalten.

◎ Les détails des accessoires inclus sont sujets à des changements.

◎ Los detalles de los accesorios incluidos pueden variar.

22. 付属品関係 / Accessories / Zubehör / Accessoires / Accessorios

REF.NO.	CODE	Q'TY	ヒンメイ	NAME OF PARTS	RMKS
17	S02761009	1	イトタテタ"イ	COTTON STAND ASSEMBLY 2	
17-1	150189009	1	フ"ラケット	COTTON STAND BASE	
17-2	S02773001	1	フ"ラケットネシ"セット	COTTON STAND BASE SCREW SET	
17-2-1	062060806	2	ナヘ"コ6X8	SCREW 6X8	
17-2-2	031452206	3	マルモク45X22	SCREW 45X22	
17-3	150172003	2	コラムパイプ	COLUMN PIPE	
17-4	150106003	1	コラムジョイントクミ	COLUMN JOINT ASSEMBLY	
17-4-1	062501406	2	ナヘ"コ5X14	SCREW 5X14	
17-4-2	021500106	2	1シユナツト5	NUT 5	
17-5	150174000	1	コラムキャツプ	COLUMN CAP	
17-6	S02778002	1	スプ"ールホルタ"-2	SPOOL HOLDER 2	
17-7	S02780001	1	スプ"ールネシ"セット2	SPOOL SCREW SET 2	
17-7-1	150179002	2	スプ"ールシ"クB	SPOOL SHAFT (B)	
17-7-2	028050246	2	ハ"ネサ"カ"ネ2-5	SPRING WASHER 2-5	
17-7-3	021500106	4	1シユナツト5	NUT 5	
17-7-4	050503006	1	ナヘ"コヒラサ"5X30	SCREW 5X30	
17-7-5	050501406	1	ナヘ"コヒラサ"5X14	SCREW 5X14	
17-8	150180001	2	ウケサ"ラ	SPOOL STAND BASE	
17-9	150182000	2	スプ"ールマット	SPOOL MAT	
17-10	126863001	2	スプ"ールクツシヨ	SPOOL CUSHION	
17-11	S02786002	1	スレツト"ハンガ"ークミ2	THREAD HANGER ASSEMBLY 2	
<メカ2ペヨウ /MECHANICAL TWO PEDALS >					
12-2	116185209	1	ヘ"タルクミ	PEDAL ASSEMBLY	
12-2-1	117437109	1	オサエアケ"フミイタ	TREADLE	
12-2-2	021400106	2	1シユナツト4	NUT 4	
12-2-3	062401416	2	ナヘ"コ4X14	SCREW 4X14	
12-2-4	116016001	2	ヘ"タルトメ	PEDAL STOPPER	
18-2	142262001	1	クサリフクミ	CHAIN (F) ASSEMBLY	
29	154739009	1	メカ2ヘ"テーフ"ルクミ	MECHANICAL TWO PEDAL TABLE ASSEMBLY	
29-1	154614001	1	クサリクミ	CHAIN ASSEMBLY	
29-2	154613009	1	レンカンレハ"-S	CONNECTING LEVER (S)	
29-3	109656009	1	レンカンレハ"-L	CONNECTING LEVER (L)	
29-4	109657009	2	フミイタシ"クウケ	TREADLE SHAFT BRACKET	
29-5	106062009	1	フミイタササエシ"ク	TREADLE SUPPORT SHAFT	
29-6	100463001	4	4カクホ"ルト7.94	BOLT 7.94	
29-7	100469002	4	サラモクネシ"5.1X26	SCREW 5.1X26	

仕様別部品一覧表 / DIFFERENT PARTS LIST / ZUBEHÖRLISTE /
LISTE DES PIÈCES ACCESSOIRES / LISTA DE PIEZAS ACCESORIAS

SUB CLASS	サンショウ ハンコウ REF.NO.	A-56	A-57	A-62	D-35	D-35-10	F-15	F-16
	ヒンメイ PARTS シヨウ SPEC	----- EYE GUARD ASSEMBLY	----- SCREW 357X5	シヨウラベル LABEL	オサエウテクミ431 PRESSER ARM ASSEMBLY 431	オサエアシ 431 WORK CLAMP FOR B431	チェンジキヤ W CHANGE GEAR (W)	チェンジキヤ C CHANGE GEAR (C)
-1	ヒョウジュンヨウ STANDARD	-----	-----	153056201	154410109 (S)	154416001 (S)	152721000 (42 シン) (STITCHES)	152722000 (42 シン) (STITCHES)
	フィンガーガード・ アイガードツキ WITH FINGER GUARD & EYE GUARD	154406001	062670512	↑	↑	↑	↑	↑
-2	ヒョウジュンヨウ STANDARD	-----	-----	153056202	↑	↑	152719000 (28 シン) (STITCHES)	152720000 (28 シン) (STITCHES)
	フィンガーガード・ アイガードツキ WITH FINGER GUARD & EYE GUARD	154406001	062670512	↑	↑	↑	↑	↑
	メカ2ペヨウ MECHANICAL TOW PEDALS	-----	-----	↑	↑	↑	↑	↑
	メカ2ペヨウ フィンガーガード・ アイガードツキ MECHANICAL TWO PEDALS (WITH FINGER GUARD & EYE GUARD)	154406001	062670512	↑	↑	↑	↑	↑
-3	ヒョウジュンヨウ STANDARD	-----	-----	153056203	154411109 (L)	154417001 (L)	↑	↑
	フィンガーガード・ アイガードツキ WITH FINGER GUARD & EYE GUARD	154406001	062670512	↑	↑	↑	↑	↑

SUB CLASS	サンショウ パンコウ REF.NO.	F-22	Q-14	Q-16	Z1-13-1	Z1-13-2	Z1-15-2	
	ヒンメイ PARTS ショウ SPEC	オクリカム 431 FEED CAM B431	ワイパー-B -----	----- FINGER GUARD	モータープーリ -----	----- MOTOR PULLEY	Vベルト V BELT	
-1	ヒョウジュンヨウ STANDARD	154421001	156035001	-----	<50HZ> 153109001 <60HZ> 153108001			
	フィンガーガード・ アイガードツキ WITH FINGER GUARD & EYE GUARD	↑	-----	S00926101	-----			
-2	ヒョウジュンヨウ STANDARD	154422001	156035001	-----	<50HZ> 153109001 <60HZ> 153108001	<50HZ> 154540001 (φ14) 154542001 (φ15.88)		
	フィンガーガード・ アイガードツキ WITH FINGER GUARD & EYE GUARD	↑	-----	S00926101	-----		<50HZ> 082105290	
	メカ2ペヨウ MECHANICAL TOW PEDALS TOW PEDALS	↑	156035001	-----	-----	<60HZ> 154541001 (φ14) 154543001 (φ15.88)	<60HZ> 082105190	
	メカ2ペヨウ フィンガーガード・ アイガードツキ MECHANICAL TWO PEDALS (WITH FINGER GUARD & EYE GUARD)	↑	-----	S00926101	-----	159929001 (φ19.05)		
-3	ヒョウジュンヨウ STANDARD	154423001	156035001	-----	<50HZ> 153109001 <60HZ> 153109001			
	フィンガーガード・ アイガードツキ WITH FINGER GUARD & EYE GUARD	↑	-----	S00926101	-----			

CODE	REF.NO.	PAGE
S00327001	H - 16	22
S00400000	H - 16-11	22
S00926101	Q - 16	36
S01300009	L - 3	30
S02761009	Z2 - 17	42
S02773001	Z2 - 17-2	42
S02778002	Z2 - 17-6	42
S02780001	Z2 - 17-7	42
S02786002	Z2 - 17-11	42
S02878000	P - 21	36
S06706001	Z1 - 16	40
S07814001	F - 31	18
S09132001	D - 12	12
	F - 20	18
	F - 29	18
	F - 32	18
S18426001	N - 1	34
S21120001	P - 26	36
013710712	F - 37	18
	F - 40	18
	Q - 13	36
013719412	A - 32-8	2
013760612	A - 52	2
	E - 5	16
	K - 32	28
013761410	B - 32	6
013761412	C - 14	10
	C - 21	10
014680422	K - 28	28
	K - 34	28
	L - 1-18	30
014680622	H - 3	22
	Q - 3	36
	Q - 9	36
014760622	B - 34	6
	B - 74	8
	D - 18	12
	D - 23	12
	D - 3	12
	D - 30-3	12
	D - 32	12
	D - 35-6	12
	D - 6-2-3	12
	E - 10	16
	E - 16	16
	E - 28	16
	E - 4	16
	F - 10	18
	F - 45	18
	G - 19-3	20
	G - 21	20
	G - 30	20
	H - 11	22
	H - 17	22
	H - 6	22
	H - 8	22
	M - 26	32
	M - 30	32
	M - 42	32
	R - 10	38
	Z1 - 14	40
014770622	C - 17	10
	C - 19	10
	D - 35-9	12
	H - 15	22
	P - 8	36
014821022	B - 6	6

CODE	REF.NO.	PAGE
014821022	G - 29	20
017062503	Z1 - 23	40
017711412	B - 59	8
017760812	Z1 - 12-1-3	40
017761412	C - 9	10
	D - 40	14
017762012	G - 36	20
017762202	B - 66	8
018060822	G - 10-3	20
018061622	B - 77	8
	F - 42	18
018062022	B - 55-3	8
	F - 25	18
	F - 8	18
018062222	F - 18	18
018063022	D - 12-1	12
	F - 20-1	18
	F - 29-1	18
	F - 32-1	18
018081222	A - 32-3	2
018082022	D - 26-2-1	12
	D - 4-1	12
018082522	B - 11	6
018500822	D - 35-13	14
	D - 35-8	12
018501422	H - 25	22
018681022	M - 3	32
021060102	Z1 - 24	40
021100202	A - 32-15	2
021400106	Z2 - 12-2-2	42
021500106	Z2 - 17-4-2	42
	Z2 - 17-7-3	42
021670202	J - 12-7	24
021680202	B - 39-7	6
021800102	B - 22	6
025060132	B - 78	8
	M - 21	32
025060232	B - 80	8
	C - 10	10
	D - 39	14
	G - 37	20
	Z1 - 12-1-6	40
025080132	A - 65	4
025080232	A - 32-4	2
	G - 33	20
025100132	A - 32-16	2
025350132	Q - 17	36
025350332	J - 12-4	24
	R - 4	38
025680132	B - 39-6	6
025770232	A - 11	2
	Q - 7	36
	R - 9	38
025800332	B - 20	6
	Z1 - 22	40
028040242	J - 51	26
028050242	B - 45	6
	B - 60	8
028050246	Z2 - 17-7-2	42
028060242	B - 79	8
	B - 82	8
	F - 27	18
	Z1 - 12-1-7	40
	Z1 - 26	40
028080242	A - 32-5	2
	B - 12	6
	G - 34	20

CODE	REF.NO.	PAGE
028100242	A - 32-17	2
031452206	Z2 - 17-2-2	42
047251640	J - 37	24
047501242	A - 71	4
048025342	A - 56-6	2
048030342	B - 39-4	6
	Q - 11	36
048040342	B - 27	6
	F - 55-2	8
	B - 43-4	18
	K - 30	28
	M - 18-3	32
	M - 28	32
	P - 1-5	36
	Q - 8	36
	R - 6	38
048050342	L - 1-17	30
	M - 37	32
	M - 5	32
	R - 8	38
048060342	E - 12	16
	E - 19	16
	Q - 4	36
048080342	H - 23	22
048100142	A - 32-13	2
048110142	B - 31	6
	B - 73	8
	E - 27	16
	M - 40	32
048120142	M - 24	32
048150142	C - 3	10
048160142	G - 26	20
048170142	G - 2	20
048180142	B - 4	6
	D - 15	12
	D - 22	12
048240242	P - 9-6	36
048320242	A - 32-2-1	2
048350142	P - 9-4	36
050501406	Z2 - 17-7-5	42
050503006	Z2 - 17-7-4	42
062060806	Z2 - 17-2-1	42
062061606	Z1 - 12-1-5	40
062401416	Z2 - 12-2-3	42
062501406	Z2 - 17-4-1	42
062660412	H - 16-4	22
062660712	H - 16-8	22
	P - 24	36
062670412	F - 49	18
	K - 45	28
062670512	A - 57	2
	J - 21	24
	J - 26	24
	J - 33	24
	J - 39	24
	J - 48	24
	J - 50	26
	Q - 15	36
062670612	J - 13	24
	K - 4	28
	K - 40	28
062670712	L - 1-19	30
	L - 1-9	30
062670812	A - 15	2
	J - 12-3	24
062671012	R - 3	38
062671212	D - 35-1-3	12

CODE	REF.NO.	PAGE
062671412	J - 12-8	24
062680612	A - 59	2
	J - 5	24
062680712	L - 1-11	30
062680812	A - 22	2
	A - 64	4
	C - 20-7	10
	J - 54	26
062681012	J - 3	24
	L - 7	30
062710612	A - 74	4
062710712	A - 6	2
	K - 2	28
062711412	A - 5	2
	A - 8	2
062761412	A - 3	2
	L - 2	30
	M - 20	32
062781412	C - 35	10
071047650	D - 38	14
071095250	P - 25	36
072600360	G - 3-2	20
072600760	P - 9-2	36
072630260	C - 5	10
081003670	H - 13	22
	H - 19	22
081008070	M - 52	32
	N - 1-15	34
082104891	Z1 - 15-1	40
082105190	Z1 - 15-2	40
082105290	Z1 - 15-2	40
100032004	M - 43	32
100136001	K - 15	28
	K - 27	28
100250001	C - 16	10
100315002	A - 10	2
100360003	M - 16	32
	N - 1-9	34
100398001	K - 9	28
100402004	K - 10	28
100463001	Z2 - 29-6	42
100469002	Z2 - 29-7	42
100887001	Z1 - 4-2	40
101572101	Z1 - 3-3	40
101706001	C - 18	10
102630001	E - 8	16
102716004	L - 1-22	30
	L - 1-5	30
102843004	C - 8	10
103950003	K - 18	28
104450109	A - 31	2
	A - 66	4
104525001	K - 14	28
	L - 3-3	30
104567001	J - 10	24
	J - 22	24
	J - 40	24
104689002	B - 23	6
	H - 2	22
105161004	A - 56-5	2
105248003	J - 65	26
105343001	Z1 - 5-6	40
105451002	D - 10	12
	D - 25	12
105812003	G - 35	20
106030001	Z1 - 19	40
106062009	Z2 - 29-5	42

CODE	REF.NO.	PAGE
106147002	B - 37	6
107149001	G - 27	20
	J - 59	26
107153002	E - 11	16
	E - 18	16
107231002	G - 9	20
107415016	C - 27	10
	Z1 - 9	40
107744001	B - 39-2	6
107779001	Z1 - 4-1	40
107780001	Z1 - 4-3	40
108265009	L - 3-4	30
108520009	A - 30	2
109239002	A - 18	2
109656009	Z2 - 29-3	42
109657009	Z2 - 29-4	42
109893002	F - 26	18
110027001	F - 44	18
110251001	B - 38	6
	B - 67	8
110495003	H - 14	22
110505001	B - 72	8
111140002	M - 13	32
	N - 1-8	34
111865009	B - 75	8
	M - 41	32
112468001	M - 36	32
112669001	J - 31	24
	J - 42	24
	J - 56	26
112751003	K - 6	28
113006001	J - 34	24
113316001	K - 5	28
113431002	B - 39-5	6
	B - 61	8
114294001	K - 17	28
114483002	Z1 - 10	40
114486002	A - 73	4
114985001	A - 58	2
115003001	P - 1-3	36
115012002	B - 13	6
115018001	B - 19	6
115077003	K - 38	28
115138001	L - 1-13	30
115157001	Z1 - 5-5	40
115493002	A - 17	2
116016001	Z2 - 12-2-4	42
116185209	Z2 - 12-2	42
116629001	Q - 5	36
116692009	Z1 - 12-1-2	40
116920001	C - 36	10
117150001	J - 25	24
	J - 38	24
117363001	B - 44	6
117437109	Z2 - 12-2-1	42
117934009	A - 29	2
117936009	A - 27	2
118064001	Z1 - 5-3	40
118837001	Z1 - 3-2	40
119709003	Z1 - 12-1-4	40
120448001	L - 1-21-2	30
	Z1 - 30	40
122991001	Z1 - 1	40
126863001	Z2 - 17-10	42
132051001	C - 20-4	10
133636009	Z1 - 12-1-1	40
140208001	K - 29	28

CODE	REF.NO.	PAGE
140208001	M - 27	32
140392009	A - 28	2
140407002	D - 35-12	14
	D - 35-7	12
140423000	J - 2-5	24
	J - 28	24
140726000	C - 11	10
141331001	D - 36-3	14
141334001	F - 47	18
	M - 48	32
141472002	G - 23	20
141528001	K - 37	28
141550001	L - 1-14	30
141583001	E - 21	16
141692001	J - 12-6	24
141786001	H - 1	22
141808001	H - 34	22
141860001	A - 32-2-2	2
142002001	Z1 - 5-1	40
142211001	C - 33	10
142262001	Z2 - 18-2	42
142443001	Z1 - 3-1	40
142566001	L - 1-16	30
142628001	B - 30	6
	B - 71	8
	E - 26	16
	M - 39	32
142721001	Z1 - 5-2	40
144226001	Z1 - 25	40
144458001	C - 24	10
144694001	J - 6	24
144712002	C - 2-1	10
145318001	D - 34	12
145446001	K - 12	28
	K - 22	28
	L - 3-2	30
145478001	D - 35-15	14
145480001	A - 12	2
145519001	K - 11	28
146375000	J - 23	24
147111001	P - 7	36
147151000	F - 3	18
147745000	J - 15	24
	J - 2-6	24
	J - 43	24
148921000	J - 14	24
150106003	Z2 - 17-4	42
150172003	Z2 - 17-3	42
150174000	Z2 - 17-5	42
150179002	Z2 - 17-7-1	42
150180001	Z2 - 17-8	42
150182000	Z2 - 17-9	42
150189009	Z2 - 17-1	42
150335001	Z1 - 5-4	40
150553001	B - 53	8
	B - 64	8
	G - 38	20
	M - 33	32
150554002	B - 14	6
150556001	B - 46-3	6
	B - 48	6
	B - 51	6
	E - 20-3	16
	E - 22	16
151163001	B - 9	6
	F - 24	18
151602002	D - 1-3	12

CODE	REF.NO.	PAGE
151604002	A - 54	2
151886001	B - 1	6
151887001	B - 3	6
151888101	B - 10	6
151889001	B - 15	6
151890000	B - 16	6
151891001	B - 17	6
151892001	B - 18	6
151893001	B - 21	6
151894101	B - 24	6
151895000	B - 25	6
151898001	B - 26	6
151899001	B - 28	6
151900001	B - 29	6
151901001	B - 33	6
151902001	B - 35	6
151903001	B - 36	6
151904101	B - 39	6
151905101	B - 39-1	6
151906101	B - 39-3	6
151907001	B - 40	6
	B - 54	8
	M - 32	32
151908001	B - 41	6
151910001	B - 43	6
151912001	B - 47	6
151913001	B - 49	6
151914001	B - 50	6
151915101	B - 52	6
151919101	B - 57	8
151920001	B - 58	8
151922001	B - 65	8
151923001	B - 68	8
151924001	B - 69	8
151925001	B - 70	8
151927001	B - 2	6
151928001	G - 1	20
151929000	B - 7	6
151930201	G - 3-1	20
151932001	G - 8	20
151933001	G - 10-1	20
151935000	G - 10-1-1	20
151936001	G - 11	20
151937001	G - 12	20
151938001	G - 13	20
151939101	B - 55	8
151940001	G - 10-2	20
151941101	G - 10-4	20
151944001	G - 19	20
151946000	P - 17	36
151947101	G - 19-1	20
151948001	G - 19-2	20
151949001	G - 20-1	20
151951001	G - 22-1	20
151952001	G - 24	20
151953001	G - 25	20
151954001	G - 28	20
151995001	C - 1	10
151997000	C - 4	10
151998000	C - 6	10
151999001	C - 7	10
152000001	C - 13	10
152191101	H - 9	22
152231000	C - 15	10
152232001	C - 20	10
152236001	C - 20-2	10
152237001	C - 20-3	10

CODE	REF.NO.	PAGE
152238001	C - 20-5	10
152239001	C - 20-6	10
152240001	C - 22	10
152242001	C - 25	10
152243001	C - 26	10
152244000	C - 34	10
152245001	H - 4	22
152246001	H - 5	22
152247001	H - 7	22
152250001	H - 10	22
152677001	H - 16-1	22
152678001	H - 12	22
	H - 18	22
152679001	H - 16-2	22
152680001	H - 16-3	22
152681201	H - 24	22
152682001	H - 26	22
152683001	H - 16-5	22
152684001	H - 16-6	22
152685101	H - 31	22
152693001	P - 1-1	36
152694001	P - 1-2	36
152695201	P - 9-1	36
152698001	P - 9-3	36
152699001	P - 9-5	36
152700000	P - 9-7	36
152701001	P - 18	36
152702001	P - 19	36
152703100	P - 20	36
152705101	P - 22	36
152706001	P - 23	36
152707001	F - 1	18
152708000	F - 4	18
152709000	F - 6	18
152710001	F - 7	18
152713001	F - 5	18
152718001	F - 2	18
152719000	F - 15	18
152720000	F - 16	18
152721000	F - 15	18
152722000	F - 16	18
152723001	F - 34	18
152724001	F - 19	18
152728001	B - 8	6
	F - 23	18
152729001	F - 28	18
152731001	F - 35	18
152732001	F - 36	18
152733001	F - 39	18
152734001	F - 41	18
152735101	F - 43	18
152739001	F - 43-2	18
152741101	D - 1	12
152742001	D - 1-1	12
152744001	E - 2-2	16
152745001	D - 2	12
	D - 31	12
152749001	D - 27	12
	D - 7	12
152750001	D - 28	12
	D - 8	12
152752001	D - 6-2-1	12
152755001	D - 11	12
152756001	B - 5	6
	D - 14	12
	D - 19	12
	D - 21	12

CODE	REF.NO.	PAGE
152758001	D - 16	12
152759001	D - 17	12
152760001	D - 20	12
152762001	D - 30	12
152765001	Z1 - 6	40
152766001	D - 33	12
152769001	D - 36	14
152771000	D - 36-1	14
152772001	D - 37	14
152773000	D - 36-2	14
152788000	D - 35-17	14
152794001	E - 1	16
152798001	E - 2-1	16
152799001	E - 3	16
152800201	E - 6	16
152801001	E - 7	16
152802001	E - 9	16
152803001	E - 13	16
152805101	E - 14-1	16
152806001	E - 14-2	16
152808101	B - 46	6
	E - 20	16
152811001	E - 23	16
152815001	Q - 1	36
152816001	Q - 2	36
152822001	Q - 6	36
152823001	Q - 10	36
152827009	Q - 12	36
152830109	A - 2	2
152831009	A - 4	2
152832109	A - 4-1	2
152833001	A - 4-2	2
152834009	A - 7	2
152835009	A - 9	2
152836009	A - 13	2
152838001	A - 60	4
152839001	A - 61	4
152841009	A - 14	2
152842009	A - 16	2
152846009	A - 19	4
152847009	A - 77	4
152848001	A - 63	4
152852101	A - 32-2	2
152857001	A - 32-6	2
152858001	A - 32-7	2
152859001	A - 32-9	2
152860009	A - 32-10	2
152861101	A - 32-11	2
152862001	A - 32-12	2
152863001	Z1 - 20	40
152864000	Z1 - 21	40
152865101	A - 32-14	2
152866001	A - 51	2
152867000	A - 53	2
152868009	A - 55	2
152869001	K - 1	28
152870001	K - 3	28
152872001	K - 8	28
152873001	K - 16	28
152875001	K - 20	28
152876001	K - 21	28
152877001	K - 23	28
152878001	K - 24	28
152879101	K - 25	28
152880001	K - 26	28
152881001	K - 31	28
152883000	K - 43	28

CODE	REF.NO.	PAGE
152884001	K - 44	28
152886001	K - 33	28
152887001	K - 35	28
152888101	K - 36	28
152889001	K - 39	28
152890001	K - 41	28
152891001	K - 42	28
152892001	M - 1	32
152893101	M - 4	32
152896001	M - 2	32
152897201	M - 9	32
	N - 1-4	34
152901001	M - 10	32
	N - 1-5	34
152904001	M - 11	32
	N - 1-6	34
152905001	M - 12	32
	N - 1-7	34
152906101	M - 50	32
	N - 1-13	34
152912001	M - 18-1	32
152913001	M - 18-2	32
152914001	B - 55-1	8
	F - 38	18
	M - 18-4	32
152915001	M - 19	32
152916001	M - 22	32
152917001	M - 23	32
152919001	M - 18-6	32
152920001	M - 29	32
152921001	M - 31	32
152922001	M - 34	32
152923001	M - 35	32
152925101	R - 1	38
152926001	R - 2	38
152929001	R - 7	38
152933001	L - 1-3	30
152934001	L - 1-4	30
152935001	L - 1-6	30
152936001	L - 1-7	30
152937001	L - 1-8	30
152938001	L - 1-10	30
152939001	L - 1-12	30
152940001	L - 1-15	30
152941001	L - 1-20	30
152945001	L - 3-1	30
152948001	J - 1	24
	J - 11	24
152949001	J - 2	24
152950001	J - 2-1	24
152951001	J - 2-2	24
152952001	J - 2-3	24
152953001	J - 45	24
152955001	J - 4-2	24
152956001	J - 4-3	24
	J - 7	24
152958001	J - 4	24
152959001	J - 4-1	24
152960001	J - 9	24
152961001	J - 12	24
152962001	J - 8	24
152963001	J - 12-5	24
152964001	J - 17	24
	J - 19	24
152965001	J - 18	24
152966001	J - 12-1	24
152967001	J - 12-2	24

CODE	REF.NO.	PAGE
152968001	J - 60	26
152969001	J - 20	24
	J - 32	24
152971001	J - 29	24
152973001	J - 36	24
	J - 67	26
152974001	J - 41	24
152976001	J - 49	26
152977001	J - 52	26
152978001	J - 53	26
152980001	B - 52-1	8
	D - 6-2-4	12
	J - 70	26
152981001	M - 7	32
	N - 1-2	34
152982109	L - 1	30
152983009	L - 1-1	30
152984001	L - 1-2	30
152985001	J - 46	24
152986001	A - 21	2
152988001	R - 5	38
152989001	A - 20	2
152992001	J - 24	24
152995001	M - 6	32
	N - 1-1	34
153035000	D - 43	14
153040001	C - 2	10
153041001	D - 1-2	12
153042001	D - 26-1	12
	D - 6-1	12
153043001	D - 30-2	12
	D - 6-2-2	12
153044001	P - 1	36
153045001	D - 24	12
	D - 9	12
153049001	K - 7	28
153050000	H - 16-9	22
153056201	A - 62	4
153056202	A - 62	4
153056203	A - 62	4
153057002	D - 42	14
153058001	P - 1-4	36
153104001	F - 17	18
153108001	Z1 - 13-1	40
153109001	Z1 - 13-1	40
153138001	K - 46	28
153141001	F - 48	18
153195001	F - 43-3	18
153208002	M - 44	32
153219001	M - 46	32
	N - 1-12	34
153220001	M - 45	32
	N - 1-11	34
153222001	M - 8	32
	N - 1-3	34
153330001	C - 20-1	10
153331001	D - 30-1	12
153332001	F - 43-1	18
153482001	M - 38	32
153528001	J - 64	26
153529101	J - 61	26
153530001	J - 62	26
153531001	J - 63-1	26
153562001	J - 63-2	26
153567000	D - 35-18	14
153571001	D - 35-11	12
153596001	M - 54	32

CODE	REF.NO.	PAGE
153596001	N - 1-17	34
153597001	M - 53	32
	N - 1-16	34
153598001	M - 51	32
	N - 1-14	34
153757001	D - 26-2	12
153762101	D - 4	12
153763001	J - 47	24
153918001	J - 2-4	24
153919001	J - 2-7	24
153921001	D - 1-5	12
153922001	J - 44	24
	J - 58	26
153924001	D - 1-4	12
153925001	J - 68	26
153926001	J - 69	26
153927001	J - 55	26
153944001	D - 35-5	12
154155101	B - 63	8
154332001	B - 46-1	6
	E - 20-1	16
154333001	B - 46-2	6
	E - 20-2	16
154339001	H - 35-1	22
154341001	H - 35-2	22
154406001	A - 56	2
154407001	A - 56-1	2
154408001	A - 56-2	2
154409009	Z1 - 12-1	40
154410109	D - 35	12
154411109	D - 35	12
154413001	D - 35-2	12
154414001	D - 35-3	12
154415001	D - 35-4	12
154416001	D - 35-10	12
154417001	D - 35-10	12
154418001	D - 35-16	14
154419201	D - 41	14
154420201	D - 41	14
154421001	F - 22	18
154422001	F - 22	18
154423001	F - 22	18
154424001	K - 19	28
154425001	Z1 - 28	40
154426001	Z1 - 32	40
154427001	Z1 - 18-1	40
154448001	G - 31	20
154449001	G - 32	20
154450001	B - 62-2	8
154451001	B - 76-2	8
154452001	G - 22-2	20
154453009	A - 19	4
154465001	A - 72	4
154528001	L - 1-21-1	30
154540001	Z1 - 13-2	40
154541001	Z1 - 13-2	40
154542001	Z1 - 13-2	40
154543001	Z1 - 13-2	40
154613009	Z2 - 29-2	42
154614001	Z2 - 29-1	42
154681001	G - 20-2	20
154702001	Z1 - 11	40
154738109	A - 32-1	2
154739009	Z2 - 29	42
154760001	Z1 - 31	40
154767001	A - 56-4	2
154774001	A - 56-3	2

CODE	REF.NO.	PAGE
154785000	A - 70	4
154788001	M - 25	32
154789001	M - 18-5	32
155336001	F - 46	18
155337001	F - 43-5	18
155489000	H - 16-10	22
155499001	B - 62-1	8
155500001	B - 76-1	8
155501001	B - 42	6
155523001	G - 10	20
156035001	Q - 14	36
156150001	M - 17	32
	N - 1-10	34
156936101	G - 3	20
158686001	E - 15	16
158687001	E - 24	16
159610101	H - 35	22
159612001	H - 35-3	22
159613001	H - 36	22
	Z1 - 7	40
159805001	K - 13	28
159808109	A - 32	2
159825009	D - 35-1-1	12
159826009	D - 35-1	12
159827001	D - 35-1-2	12
159828001	D - 35-14	14
159929001	Z1 - 13-2	40
159977000	F - 9	18
159978001	F - 11	18
159979001	F - 12	18
159984001	F - 13	18
183686001	P - 9	36
402887001	H - 16-7	22



brother

ブラザー工業株式会社

〒467 名古屋市瑞穂区河岸一丁目1番1号
TEL (052) 824-2392代

BROTHER INDUSTRIES, LTD. NAGOYA, JAPAN

118-431
195431-201
1991, 01

Printed in Japan/Gedruckt in Japan/Imprimé au Japon/Impreso en Japón