

PARTS BOOK
FOR
BROTHER LK3-B826, B828

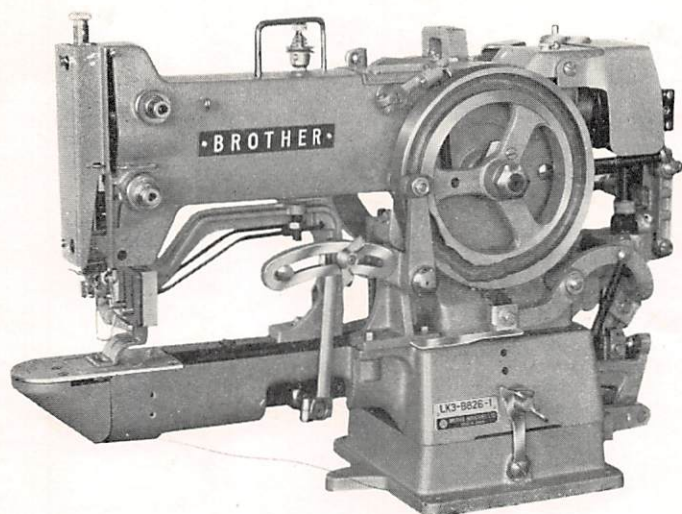

Please clarify Ref. No. and
Parts No. as well as parts name
When you place an order.

BROTHER INDUSTRIES, LTD.
NAGOYA, JAPAN.

PARTS BOOK for LK3-B826, B828

INDEX

Parts. No.	Ref. No.	Remark	Parts. No.	Ref. No.	Remark	Parts. No.	Ref. No.	Remark	Parts. No.	Ref. No.	Remark
001401-4-16	Z-40		021680-3-03	I-49		100280-0-01	G-3		115404-0-01	B-7	
009639-4-14	G-10		021710-2-02	C-29		100388-0-03	B-44		115406-0-01	H-7	
009660-6-13	H-52		021710-2-03	F-48			H-84		115407-0-01	H-1	
009661-4-12	F-7			G-33		100472-0-01	Z-4		115408-0-01	F-46	
009670-4-13	H-19			H-3		100496-0-01	G-1		115409-0-01	H-13	
009670-5-13	D-32			H-16		100887-0-01	Z-8		115410-0-01	H-71	
009670-6-13	E-28, H-23			H-76		101275-0-04	D-43		115412-0-01	H-5	
009670-8-13	F-56		021750-3-03	F-15		101531-0-03	A-56		115414-0-01	E-2	
009671-0-13	A-1, I-54, G-6		021760-2-02	G-43		101706-0-01	B-23		115415-0-01	F-49	
009671-6-13	H-21			I-2		102538-0-02	E-22		115416-0-01	H-17	
009679-3-14	B-10			I-12		102626-0-05	B-8		115417-0-01	H-22	
009680-6-13	H-2		021760-2-03	F-22		102731-0-02	A-82		115418-0-01	H-20	
009680-7-13	A-17			I-6		103013-0-01	G-4		115419-0-01	H-18	
	D-12		021760-3-02	C-46		103317-0-01	A-67		115420-0-01	B-29	
009680-8-12	A-6		021760-3-03	D-39		104212-0-02	A-62		115423-0-01	C-10	
009681-0-12	C-42			G-56		104525-0-01	H-81		115426-0-02	C-7	
009681-0-13	F-50			I-27		104649-0-01	H-37		115427-0-01	C-8	
009681-0-13	I-34			I-44		104689-0-01	B-41		115429-0-01	C-13	
009681-2-13	G-19		021780-2-03	D-17		104842-0-01	H-14		115431-0-01	B-36	
009681-4-13	F-14		021780-3-03	H-86		105034-0-01	F-64		115432-0-01	B-40	
	F-43		021860-2-03	C-36		105161-0-03	F-71		115433-0-01	B-37	
009681-4-14	D-15		022680-3-02	F-13			F-72		115434-0-01	B-42	
009710-7-13	B-48		022760-3-03	F-30		105230-0-01	H-31		115435-0-01	B-43	
009710-7-13	E-1		022840-3-03	A-27		105333-0-01	G-37		115438-0-01	B-46	
009710-7-13	G-21		025060-2-32	A-76		105343-0-01	Z-5		115442-0-01	A-15	
	I-51			C-56		105771-0-11	B-11, Z-17		115445-0-01	F-44	
009710-8-13	I-57			Z-34		105771-0-14	B-11, Z-17		115446-0-01	A-16	
009711-0-13	D-11		025060-2-33	E-24		105771-0-16	B-11, Z-17		115447-0-01	D-30	
	E-41			G-39		105827-0-01	B-53		115448-0-01	D-38	
009711-2-13	H-8			I-7		105844-0-03	D-41		115449-0-01	D-40	
	H-12		025060-3-32	Z-35		105872-0-01	E-37		115450-0-01	D-34	
	H-77		025060-3-33	C-24			D-27		115451-0-01	D-33	
009711-4-13	D-6		025060-3-33	C-64		105955-0-01	F-61		115452-0-01	D-37	
009711-4-13	H-72			G-29		105965-0-02	F-68		115453-0-01	F-10	
009712-0-13	H-4		025080-1-32	C-48		105966-0-00	F-60		115454-0-01	F-3	
009760-8-13	C-63		025080-2-33	A-79		105968-0-01	F-58		115455-0-01	D-17 ~ 27	
009761-0-13	A-29		025100-1-32	C-30		105970-0-01	F-59		115456-0-01	D-22	
	E-23			C-38		106008-0-01	G-13		115457-0-01	D-26	
009761-2-13	A-11		025350-3-33	G-59		106011-0-01	G-12		115458-0-01	G-32	
	C-25		025710-1-32	E-44		106149-0-02	H-15		115459-0-01	G-34	
	G-38		025710-1-32	F-33		106505-0-01	C-18		115460-0-01	D-23	
009761-4-13	A-32			I-29		106812-0-01	A-34		115461-0-01	D-13 ~ 21	
009761-4-13	G-30			I-33		107038-0-11	E-3		115462-0-01	D-14	
	G-57			I-58		107331-0-01	A-51		115463-0-01	D-16	
009762-0-13	F-29		025750-2-33	F-16		107428-0-01	B-34		115464-0-01	D-21	
009780-8-12	A-3		025770-2-33	C-61		107498-0-01	D-24		115465-0-01	D-13	
009781-4-13	A-13			C-69			E-34		115466-0-01	E-25, 31, 34 ~ 40	
009841-6-13	F-28			D-18		107732-0-01	F-11		115467-0-01	E-40	
009872-2-13	C-72			D-25		107779-0-01	Z-9		115468-0-01	E-38	
012770-6-22	B-61			E-15		107780-0-01	Z-7		115469-0-01	E-36	
013660-6-10	H-33			E-35		107793-0-00	F-20		115470-0-01	E-18	
013710-7-13	B-12			F-39		108721-0-01	H-28		115471-0-01	E-19	
013710-7-13	H-79		028040-1-43	F-73			H-82		115472-0-01	E-16	
	I-18		028040-2-43	G-58		108920-0-01	Z-16		115474-0-01	F-67	
013711-0-10	G-14		028050-2-40	C-28		108960-0-03	H-47		115476-0-01	E-3 ~ 33, 44	
013760-6-10	C-44			E-17		108960-0-03	H-49		115477-0-01	E-9	
	E-42			F-47		109405-0-01	B-4		115478-0-01	E-7	
013760-7-10	F-21			H-73		109763-0-01	I-41		115479-0-01	E-6	
013760-8-10	B-38		028060-1-40	A-71		109993-0-01	B-5		115481-0-01	E-8	
	C-53		028060-2-40	F-23		110436-0-01	Z-1		115482-0-11	E-4	
	F-4		028060-2-42	G-27		110820-0-01	H-27		115483-0-01	E-11	
	H-38		028080-2-43	A-83		111196-0-01	Z-44		115484-0-11	E-10	
013761-2-10	B-19		028770-2-40	F-2		111463-0-01	B-1		115485-0-01	E-12	
	B-24		028770-2-43	A-78		111941-0-01	A-63		115486-0-01	E-26	
	B-28		031482-5-03	A-43		111942-0-01	A-64		115487-0-01	E-32	
	B-33		033351-3-03	A-48		111943-0-01	A-65		115488-0-01	F-42	
	C-45		046301-6-20	B-45		111946-0-02	A-59		115489-0-01	B-9	
013761-2-12	C-16		046302-5-20	A-33		111948-0-01	A-52		115490-0-01	E-21	
013780-7-10	B-20		047302-2-42	C-6		111950-0-01	A-55		115491-0-01	E-27	
013780-8-10	G-15			D-28		112547-0-01	A-81		115492-0-01	E-29	
014760-6-22	B-31			G-35		112828-0-00	Z-43		115493-0-01	E-30	
014760-6-22	C-4		047502-2-42	C-5		113431-0-02	E-44		115494-0-01	E-25	
	D-31		047502-8-42	A-50		114483-0-01	Z-14		115495-0-01	D-9	
	G-24		047503-2-42	D-29		115377-0-01	A-18		115496-0-01	D-7	
017761-2-13	C-70			F-5		115382-0-01	A-45		115497-0-01	D-10	
	I-19		048100-1-40	C-39		115383-0-01	A-7		115498-0-01	D-5	
017761-4-13	E-14		072600-4-80	C-1		115385-0-01	A-24		115499-0-01	D-4	
017761-6-13	C-60		100032-0-01	F-57		115388-0-01	A-22		115500-0-01	D-2	
	E-43		100032-0-04	F-54		115389-0-01	A-23		115501-0-01	D-3	
	G-26		100075-0-03	E-13			C-50		115502-0-01	D-1	
017762-0-12	C-57		100075-0-04	C-74			D-19		115503-0-01	E-31	
017781-4-13	F-40		100080-0-01	A-66		115390-0-01	A-21		115506-0-01	F-25	
017782-0-13	F-1		100105-0-04	B-51		115391-0-01	B-26		115507-0-01	F-24	
021060-1-02	A-77		100117-0-01	Z-18		115392-0-00	B-25		115508-0-01	F-26	
	Z-36		100117-0-01	B-58		115393-0-00	B-27		115509-0-01	F-27	
021086-2-02	F-51		100136-0-01	H-45		115394-0-00	B-32		115510-0-01	F-19	
021400-1-06	Z-41			H-80		115395-0-00	B-22		115511-0-01	F-37	
021670-2-03	C-17		100242-0-04	A-74		115401-0-01	B-2		115512-0-01	F-55	
	F-34		100250-0-01	B-21		115402-0-01	B-3		115513-0-01	F-31	
021680-2-02	F-70		100253-0-01	B-15		115403-0-01	B-6		115514-0-01	G-31	

Parts. No.	Ref. No.	Remark	Parts. No.	Ref. No.	Remark	Parts. No.	Ref. No.	Remark	Parts. No.	Ref. No.	Remark
115515-0-01	B-39		116828-0-01	B-59		118404-0-01	H-85				
115516-0-01	F-35		116830-0-01	D-32-37		118405-0-01	H-83				
115517-0-01	F-53			F-7-10		118406-0-01	H-78				
115518-0-01	F-38		116832-0-01	F-15-26		118530-0-01	D-32-37				
115519-0-01	C-75		116833-0-01	F-38-52		118531-0-01	E-7				
	G-51		116834-0-01	F-37,55,56,71		118532-0-01	E-6				
	I-3		116835-0-01	A-2		118533-0-01	E-32				
	I-9		117143-0-01	E-5		118577-0-01	G-48				
115521-0-01	G-16			I-35		118853-0-01	B-30				
115525-0-01	G-18		117309-0-10	A-5		118872-0-01	F-60				
115526-0-01	I-56		117310-0-01	A-4		120448-0-01	A-60				
115527-0-01	I-55		117348-0-01	C-14			Z-19				
115528-0-01	A-46		117363-0-01	F-32		122738-0-01	Z-2				
115529-0-01	G-53		117363-0-01	I-28		122739-0-01	Z-3				
115530-0-01	G-23		117426-0-00	Z-43,B-49		140555-0-01	D-36				
115531-0-01	G-25		117437-0-01	Z-38		140557-0-01	D-8				
115532-0-01	G-28			D-32-37		140560-0-01	B-62				
115533-0-01	G-49		117489-0-01	F-7-10		140577-0-01	A-54				
115534-0-01	G-41		117490-0-01	D-34		141026-0-00	A-80				
115537-0-01	G-36		117491-0-01	D-37		141099-0-01	G-2				
115538-0-01	C-15-57		117492-0-01	D-35		142122-0-01	D-42				
115539-0-01	C-52		117493-0-01	F-7-10		142216-0-01	D-20				
115540-0-01	C-55		117494-0-01	F-10		142566-0-01	A-53				
115541-0-01	A-44		117495-0-01	F-9		142721-0-01	Z-11				
115542-0-01	C-23		117496-0-01	F-8		142972-0-01	Z-42				
115544-0-01	C-22		117497-0-01	E-7		143234-0-01	A-19				
115546-0-01	C-27		117498-0-01	E-6		143235-0-01	A-19				
115547-0-01	C-33		117499-0-01	E-32		143237-0-01	A-19				
115548-0-01	C-34		117502-0-01	B-29		143302-0-01	A-19				
115549-0-01	C-35		117503-0-01	D-30		143941-0-01	C-26				
115550-0-01	C-32		117524-0-01	E-3-33,E-44		144105-0-00	H-30				
115551-0-01	C-31		117526-0-01	A-4-6		144226-0-01	Z-15				
115552-0-01	C-37		117671-0-02	B-60		144543-0-01	A-75				
115553-0-01	C-54		117770-0-01	H-48			Z-33				
115554-0-01	C-15		117771-0-01	H-50		145277-0-03	Z-13				
115555-0-00	C-71		117771-0-01	Z-20		145831-0-01	E-33				
115556-0-01	C-73		118199-0-01	G-54			I-53				
115558-0-02	C-21		118200-0-01	H-75		180505-0-01	B-50-57				
115559-0-01	A-70		118201-0-01	H-74		180804-0-01	F-17				
	C-20		118202-0-01	G-55		180868-0-01	H-36-45				
	C-58		118205-0-01	D-34		181000-0-01	B-13-18				
	H-6		118206-0-01	F-10		181003-0-01	B-34-35				
115560-0-01	C-19		118207-0-01	D-34		181004-0-01	F-11-18				
115561-0-01	C-43		118235-0-01	G-52			F-72-73				
115562-0-01	C-41		118236-0-00	A-72		181021-0-01	F-62,69				
115564-0-01	C-40			G-50		181044-0-01	A-47				
115567-0-11	C-49			I-4		182097-0-01	F-58-60				
115568-0-01	D-35			I-10		182330-0-01	C-11,12				
115569-0-01	C-47		118237-0-01	I-1		182353-0-01	C-3,9				
115570-0-01	C-51		118238-0-01	I-5		182374-0-01	F-58-60				
115571-0-01	H-32		118239-0-01	I-8		403865-0-01	E-20				
115572-0-01	C-60-70		118240-0-01	I-14			E-39				
115573-0-01	C-65		118241-0-01	I-17		510032-0-01	I-20				
115574-0-01	C-68		118242-0-01	I-16							
115575-0-01	C-67		118243-0-01	I-11							
115577-0-01	C-62		118244-0-01	I-13							
115578-0-01	F-65			I-36							
115579-0-01	C-66		118245-0-01	I-15							
115580-0-01	C-59		118246-0-01	I-30							
115581-0-01	F-66		118247-0-01	I-42							
115582-0-01	F-63		118248-0-01	I-43							
115583-0-01	A-30		118249-0-01	I-37							
115584-0-01	A-28		118250-0-01	I-38							
115585-0-01	A-26		118251-0-01	I-31							
115586-0-00	A-31		118252-0-01	I-32							
115587-0-01	A-35		118253-0-01	I-39							
115588-0-01	A-36		118254-0-01	I-40							
115589-0-01	G-9-13		118255-0-01	I-52							
115590-0-01	G-11		118256-0-01	I-46							
115591-0-01	G-9		118257-0-01	I-47							
115592-0-01	F-45		118258-0-01	I-45							
115595-0-01	H-46		118259-0-01	I-48							
115596-0-01	F-9		118260-0-01	I-23							
115597-0-01	F-8		118261-0-01	I-26							
115598-0-01	F-52		118262-0-01	I-21							
115599-0-00	H-35		118263-0-01	I-22							
115600-0-01	H-34			I-24							
115601-0-01	F-41		118264-0-01	I-25							
115602-0-01	G-42		118265-0-01	I-50							
115603-0-01	F-36		118272-0-01	D-32-37							
115606-0-01	H-26		118273-0-01	F-7-10							
115610-0-01	H-51		118277-0-01	D-32-37							
115612-0-01	B-47		118314-0-01	I-11-45							
115625-0-01	G-20		118384-0-01	C-2							
115958-0-01	H-29		118386-0-01	A-73							
116016-0-01	Z-39		118387-0-01	A-49-72							
116231-0-01	A-20		118388-0-01	A-49							
116715-0-01	Z-6		118390-0-01	A-68							
116824-0-01	A-14		118391-0-01	A-58							
116827-0-01	B-54		118392-0-01	A-69							

A

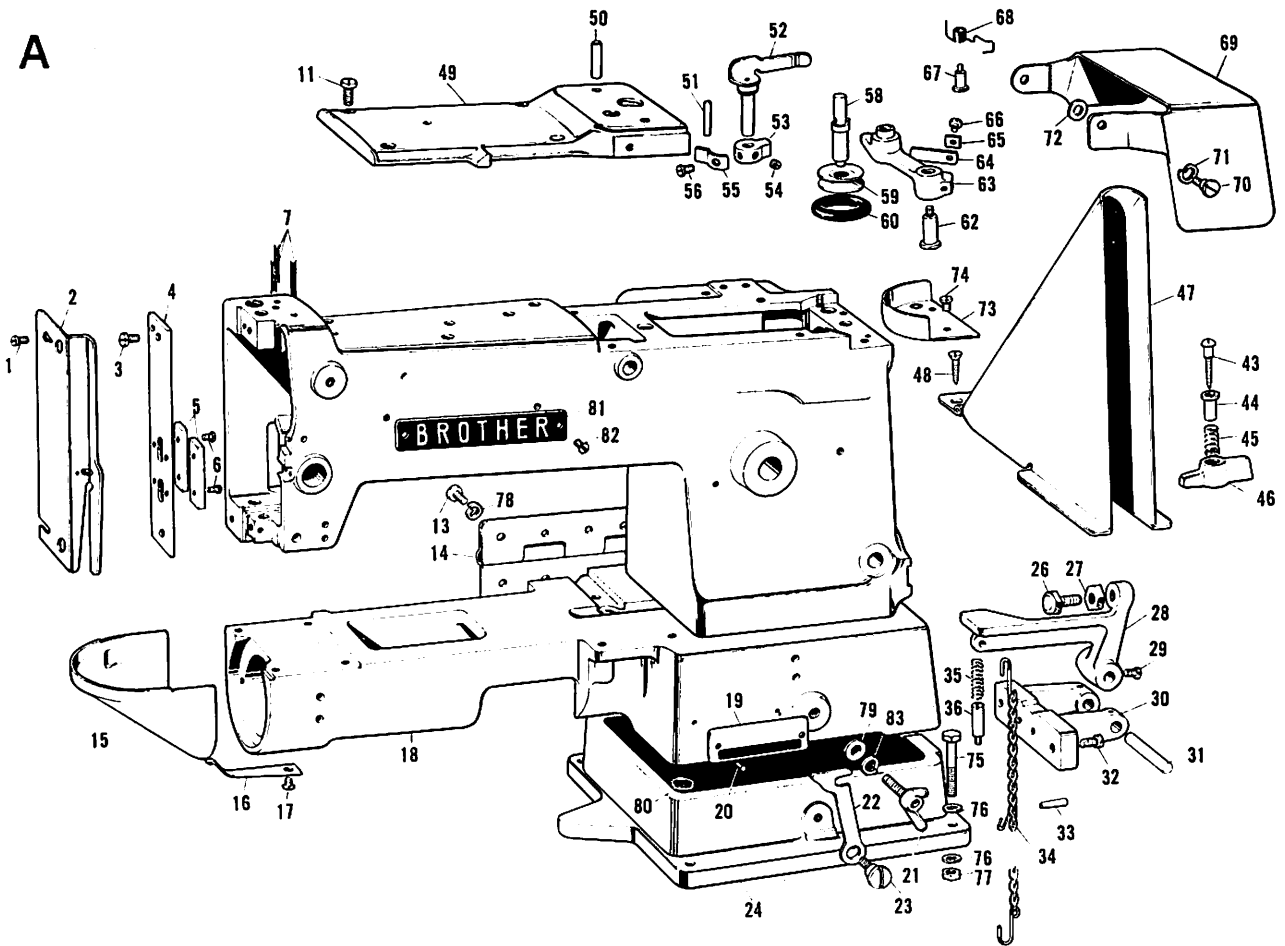

Ref. No.	Name of parts	Q'ty	Parts No.	Assembly No.	Ref. No.	Name of parts	Q'ty	Parts No.	Assembly No.
A-1	Screw	1 pce.	009671-0-13		A-52	Bobbin Presser	1 pce.	111948-0-01	
A-2	Face Plate Assembly	1	116835-0-01		A-53	Bobbin Winder Pawl	1	142566-0-01	
A-3	Screw	2 pcs.	009780-8-12		A-54	Screw	1	140577-0-01	
A-4	Needle Bar Guide Plate	1 pce.	117310-0-01		A-55	Stopper for Bobbin Presser	1	111950-0-01	
A-5	Needle Bar Guide	2 pcs.	117309-0-10	117526-0-01	A-56	Screw		101531-0-03	
A-6	Screw	4	009680-8-12		A-58	Bobbin Winder Shaft	1	118391-0-01	
A-7	12x12 Wick	3	115383-0-01		A-59	Bobbin Winder Wheel	2 pcs.	111946-0-02	
A-11	Screw	4	009761-2-13		A-60	Rubber Ring	1 pce.	120448-0-01	
A-13	Screw	8	009781-4-13		A-62	Stud Screw	1	104212-0-02	
A-14	Bed Hinge Assembly	1 pce.	116824-0-01		A-63	Bobbin Winder Shaft Holding Bracket	1	111941-0-01	118387-0-01
A-15	Shuttle Race Cover Assembly	1	115442-0-01		A-64	Elastic Plate	1	111942-0-01	
A-16	Spring	1	115446-0-01		A-65	Washer	1	111943-0-01	
A-17	Screw	1	009680-7-13		A-66	Set Screw	1	100080-0-01	
A-18	Arm Bed Assembly	1	115377-0-01		A-67	Stud Screw	1	103317-0-01	
A-19	Model Plate	1			A-68	Spring	1	118390-0-01	
A-20	Knock Pin	2 pcs.	116231-0-01		A-69	Pulley Cover	1	118392-0-01	
A-21	Wing Screw	1 pce.	115390-0-01		A-70	Screw	2 pcs.	115559-0-01	
A-22	Bed Supporter Hook	1	115388-0-01		A-71	Spring Washer	2	028060-1-40	
A-23	Stud Screw	1	115389-0-01		A-72	Washer	2	118236-0-00	
A-24	Bed Base	1	115385-0-01		A-73	Daster Plate	1 pce.	118386-0-01	
A-26	Bolt	1	115585-0-01		A-74	Saster Screw	2 pcs.	100242-0-04	
A-27	Nut	1	022840-3-03		A-75	Bolt	4	144543-0-01	
A-28	Starting Lever	1	115584-0-01		A-76	Washer	8	025060-2-32	
A-29	Screw	1	009761-0-13		A-77	Nut	4	021060-1-02	
A-30	Starting Lever Holder	1	115583-0-01		A-78	Washer	8	028770-2-43	
A-31	Starting Lever Shaft	1	115586-0-00		A-79	Washer	1 pce.	025080-2-33	
A-32	Screw	2 pcs.	009761-4-13		A-80	Rubber Cushion	4 pcs.	141026-0-00	
A-33	Taper Pin for A-30	2	046302-5-20		A-81	Name Plate	1 pce.	112547-0-01	
A-34	Starting Lever Connecting Chain (B)	1 pce.	106812-0-01		A-82	Screw	2 pcs.	102731-0-02	
A-35	Starting Lever Spring	1	115587-0-01		A-83	Spring Washer	1 pce.	028080-2-43	
A-36	Starting Lever Spring Stud	1	115588-0-01						
A-43	Screw	2 pcs.	031482-5-03						
A-44	Collar	2	115541-0-01						
A-45	Spring	2	115382-0-01						
A-46	Belt Guard Setter	2	115528-0-01						
A-47	Belt Cover Assembly	1 pce.	181044-0-01						
A-48	Screw	2 pcs.	033351-3-03						
A-49	Arm Cover	1 pce.	118388-0-01						
A-50	Spring Pin	1	047502-8-42	118387-0-01					
A-51	Pin	1	107331-0-01						

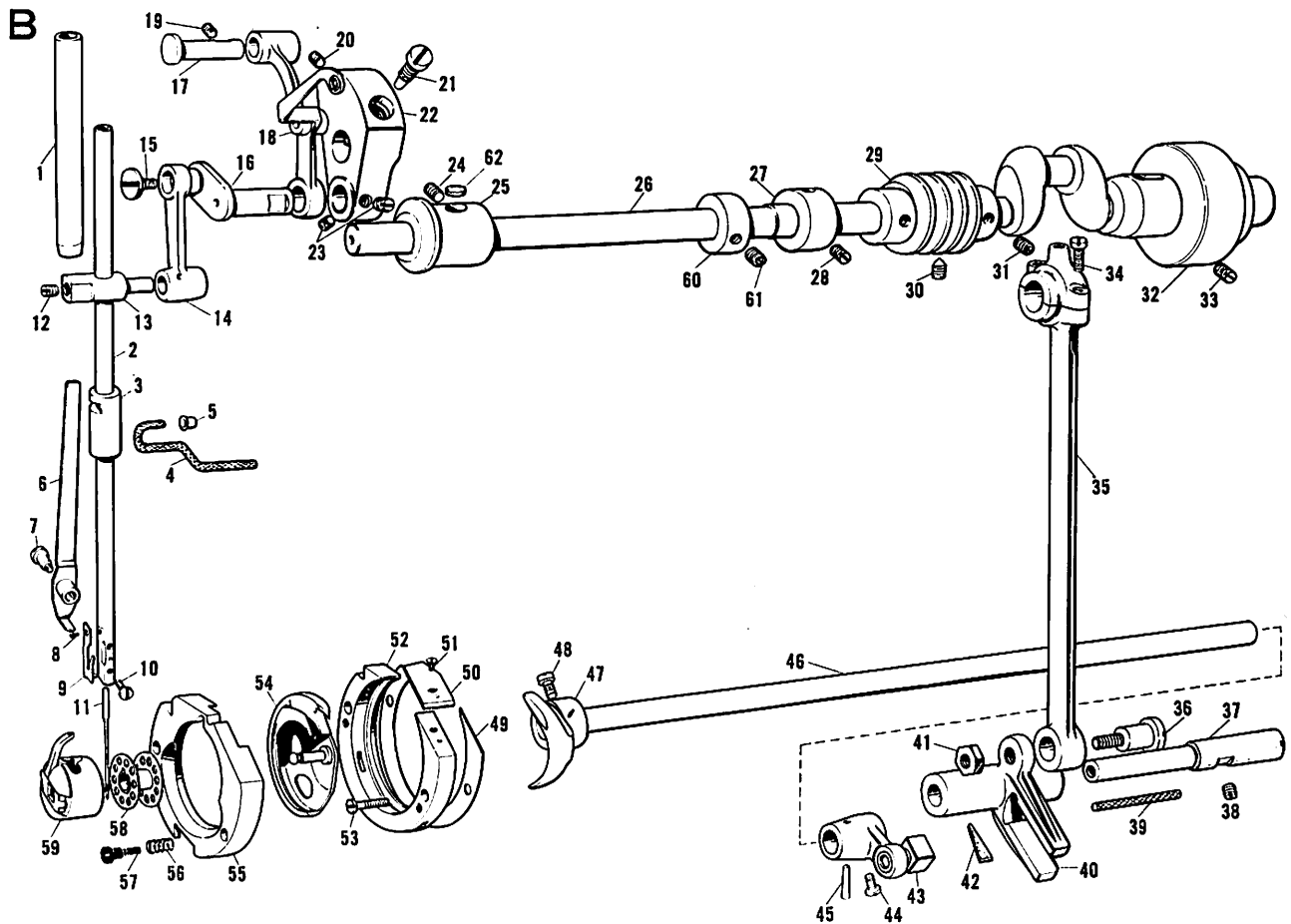

Ref. No.	Name of parts	Q'ty	Parts No.	Assembly No.	Ref. No.	Name of parts	Q'ty	Parts No.	Assembly No.
B-1	Needle Bar Bushing Upper	1 pce.	111463-0-01		B-37	Oscillating Rock Shaft	1 pce.	115433-0-01	
B-2	Needle Bar	1 "	115401-0-01		B-38	Screw	1 "	013760-8-10	
B-3	Needle Bar Bushing Lower	1 "	115402-0-01		B-39	Wick	1 "	115515-0-01	
B-4	Wick 4x4	1 "	109405-0-01		B-40	Oscillating Rock Body	1 "	115432-0-01	
B-5	Wick Stopper	1 "	109993-0-01		B-41	Nut	1 "	104689-0-01	
B-6	Nipper Fastening Plate	1 "	115403-0-01		B-42	(Fel Felt)	1 "	115434-0-01	
B-7	Stud Screw	1 "	115404-0-01		B-43	Slide Block Assembly	1 "	115435-0-01	
B-8	Screw	1 "	102626-0-05		B-44	Screw	1 "	100388-0-03	
B-9	Thread Nipper Spring	1 "	115489-0-01		B-45	Taper Pin	1 "	046301-6-20	
B-10	Screw	1 "	009679-3-14		B-46	Shuttle Driver Shaft	1 "	115438-0-01	
B-11	Needle LQx5	1 "			B-47	Shuttle Driver	1 "	115612-0-01	
B-12	Screw	1 "	013710-7-13		B-48	Screw	2 pcs.	009710-7-13	
B-13	Needle Bar Clamp	1 "			B-49	Shuttle Race Washer			
B-14	Needle Bar Crank Rod	1 "			B-50	Shuttle Race Thread Guide	1 pce.		
B-15	Screw	1 "	100253-0-01	181000-0-01	B-51	Screw	1 "	100105-0-04	
B-16	Needle Bar Crank	1 "			B-52	Shuttle Race	1 "		180505-0-01
B-17	Stud	1 "			B-55	Shuttle Race Ring	1 "		
B-18	Thread Take-up Lever	1 "			B-56	Presser Spring	1 "		
B-19	Screw	1 "	013761-2-10		B-57	Screw	1 "		
B-20	Screw	1 "	013780-7-10		B-53	Screw	2 pcs.	105827-0-01	
B-21	Stud Screw	1 "	100250-0-01		B-54	Shuttle Hook	1 pce.	116827-0-01	
B-22	Counter Weight	1 "	115395-0-00		B-58	Bobbin	1 "	100117-0-01	
B-23	Screw	2 pcs.	101706-0-01		B-59	Bobbin Case	1 "	116828-0-01	
B-24	Screw	1 pce.	013761-2-10		B-60	Collar	1 "	117671-0-02	
B-25	Upper Shaft Bushing Left	1 "	115392-0-00		B-61	Screw	2 pcs.	012770-6-22	
B-26	Upper Shaft	1 "	115391-0-01		B-62	Felt	1 pce.	140560-0-01	
B-27	Upper Shaft Bushing Intermediate	1 "	115393-0-00						
B-28	Screw	1 "	013761-2-10						
B-29	Worm	1 "							
B-30	Screw	2 pcs.	118853-0-01						
B-31	Screw	4 "	014760-6-22						
B-32	Upper Shaft Bushing Right	1 pce.	115394-0-00						
B-33	Screw	1 "	013761-2-10						
B-34	Screw	2 pcs.	107428-0-01	181003-0-01					
B-35	Crank Rod	1 pce.							
B-36	Stud Screw	1 "	115431-0-01						

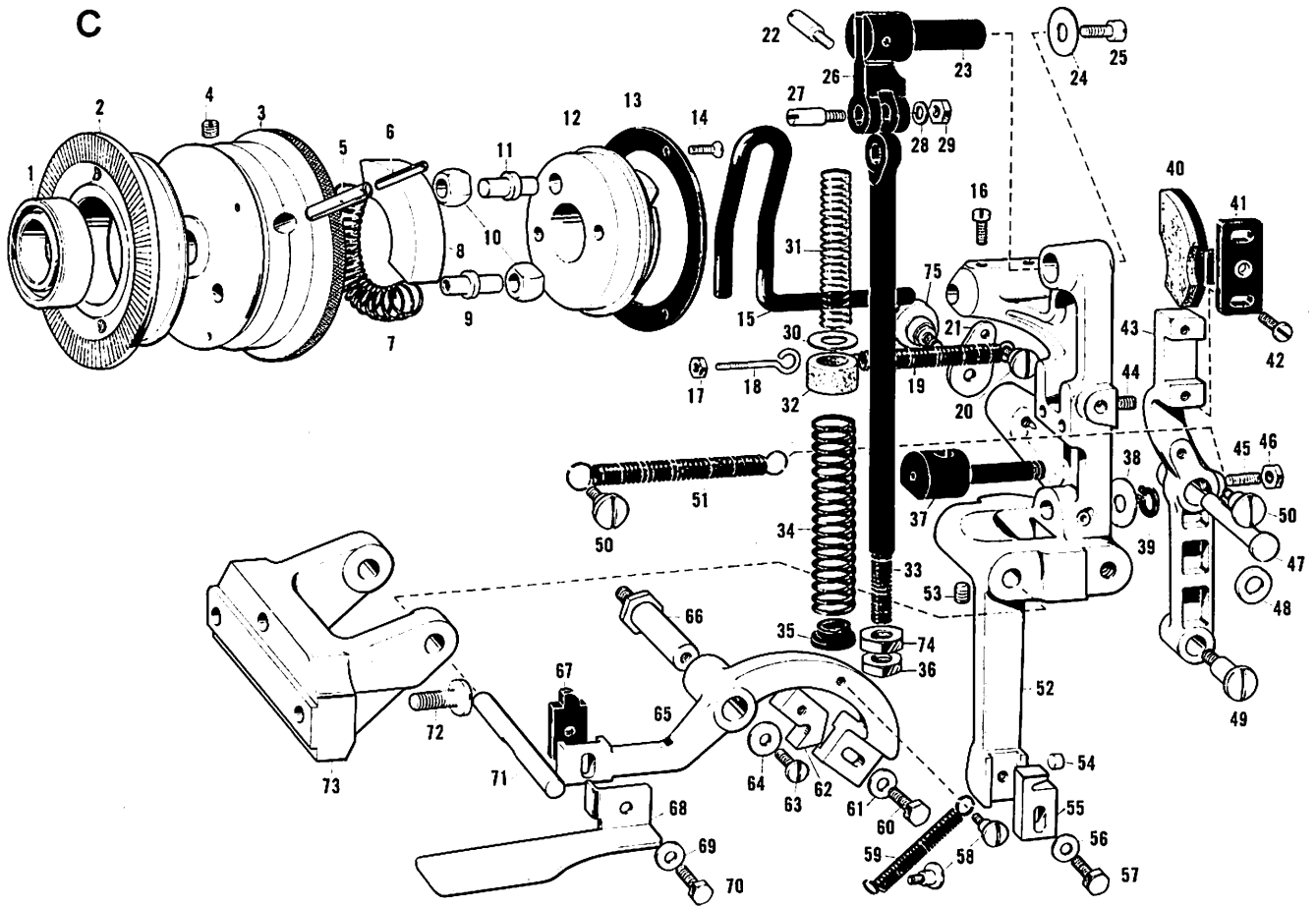

Ref. No.	Name of parts	Q'ty	Parts No.	Assembly No.	Ref. No.	Name of parts	Q'ty	Parts No.	Assembly No.
C- 1	Ball Bearing	1 pce.	072600-4-80		C-44	Screw	1 pce.	013760-6-10	
C- 2	Idle Pulley	1 "	118384-0-01		C-45	Screw	1 "	013761-2-10	
C- 3	Drive Pulley	1 "		182353-0-01	C-46	Nut	1 "	021760-3-02	
C- 9	Roller Shaft (B)	1 "			C-47	Brake Lever Guide Stud	1 "	115569-0-01	
C- 4	Screw	1 "	014760-6-22		C-48	Washer	1 "	025080-1-32	
C- 5	Spring Pin	1 "	047502-2-42		C-49	Stud Screw	1 "	115567-0-11	115538-0-01
C- 6	Spring Pin	1 "	047302-2-42		C-52	Clutch Lever	1 "	115539-0-01	
C- 7	Plunge Spring	1 "	115426-0-02		C-54	Clutch Lever Bushing	1 "	115553-0-01	
C- 8	Plunge Spring Holber	1 "	115427-0-01		C-55	Clutch Lever Pawl	1 "	115540-0-01	
C-10	Roller	2 pcs.	115423-0-01		C-56	Washer	1 "	025060-2-32	
C-11	Roller Shaft (A) for Stop Cam	1 pce.		182330-0-01	C-57	Bolt	1 "	017762-0-12	
C-12	Stop Cam	1 "			C-50	Stud Screw	2 pcs.	115389-0-01	
C-13	Stop Cam Ring	1 "	115429-0-01		C-51	Brake Spring	1 pce.	115570-0-01	
C-14	Screw	3 pcs.	117348-0-01		C-53	Screw	1 "	013760-8-10	
C-16	Screw	2 "	013761-2-12		C-58	Stud Screw	2 pcs.	115559-0-01	
C-17	Nut	1 pce.	021670-2-03		C-59	Clutch Tripping Lever Spring	1 pce.	115580-0-01	
C-18	Hook	1 "	106505-0-01		C-60	Bolt	1 "	017761-6-13	
C-19	Clutch Lever Spring	1 "	115560-0-01		C-61	Washer	1 "	025770-2-33	
C-20	Stud Screw	1 "	115559-0-01		C-62	Clutch Stopper Pawl	1 "	115577-0-01	
C-15	Belt Shifter	1 "	115554-0-01		C-65	Clutch Tripping Lever	1 "	115573-0-01	115572-0-01
C-21	Adjusting Plate	1 "	115558-0-02		C-67	Tripping Dog	1 "	115575-0-01	
C-22	Clutch Stopper Holder Stud	1 "	115544-0-01		C-68	Hand Stop Lever	1 "	115574-0-01	
C-23	Clutch Stopper Holder	1 "	115542-0-01		C-69	Washer	1 "	025770-2-33	
C-24	Washer	1 "	025060-3-33		C-70	Bolt	1 "	017761-2-13	
C-25	Screw	1 "	009761-2-13		C-63	Screw	1 "	009760-8-13	
C-26	Clutch Stopper	1 "	143941-0-01		C-64	Washer	1 "	025060-3-33	
C-27	Clutch Stopper Stud	1 "	115546-0-01		C-66	Stud Screw	1 "	115579-0-01	
C-28	Spring Washer	1 "	028050-2-40		C-71	Clutch Lever Shaft	1 "	115555-0-00	
C-29	Nut	1 "	021710-2-02		C-72	Screw	3 pcs.	009872-2-13	
C-30	Washer	1 "	025100-1-32		C-73	Clutch Lever Bracket	1 pce.	115556-0-01	
C-31	Stopper Spring (B)	1 "	115551-0-01	115538-0-01	C-74	Nut	1 "	100075-0-04	
C-32	Felt	1 "	115550-0-01		C-75	Stud Screw	1 "	115519-0-01	
C-33	Stopper Adjusting Spring Shaft	1 "	115547-0-01						
C-34	Stopper Spring (A)	1 "	115548-0-01						
C-35	Washer	1 "	115549-0-01						
C-36	Nut	1 "	021860-2-03						
C-37	Holder	1 "	115552-0-01						
C-38	Washer	1 "	025100-1-32						
C-39	Stop Ring	1 "	048100-1-40						
C-40	Brake Shoe	1 "	115564-0-01						
C-41	Brake Shoe Guide Plate	1 "	115562-0-01						
C-42	Screw	2 pcs.	009681-0-12						
C-43	Brake Lever	1 pce.	115561-0-01						

D

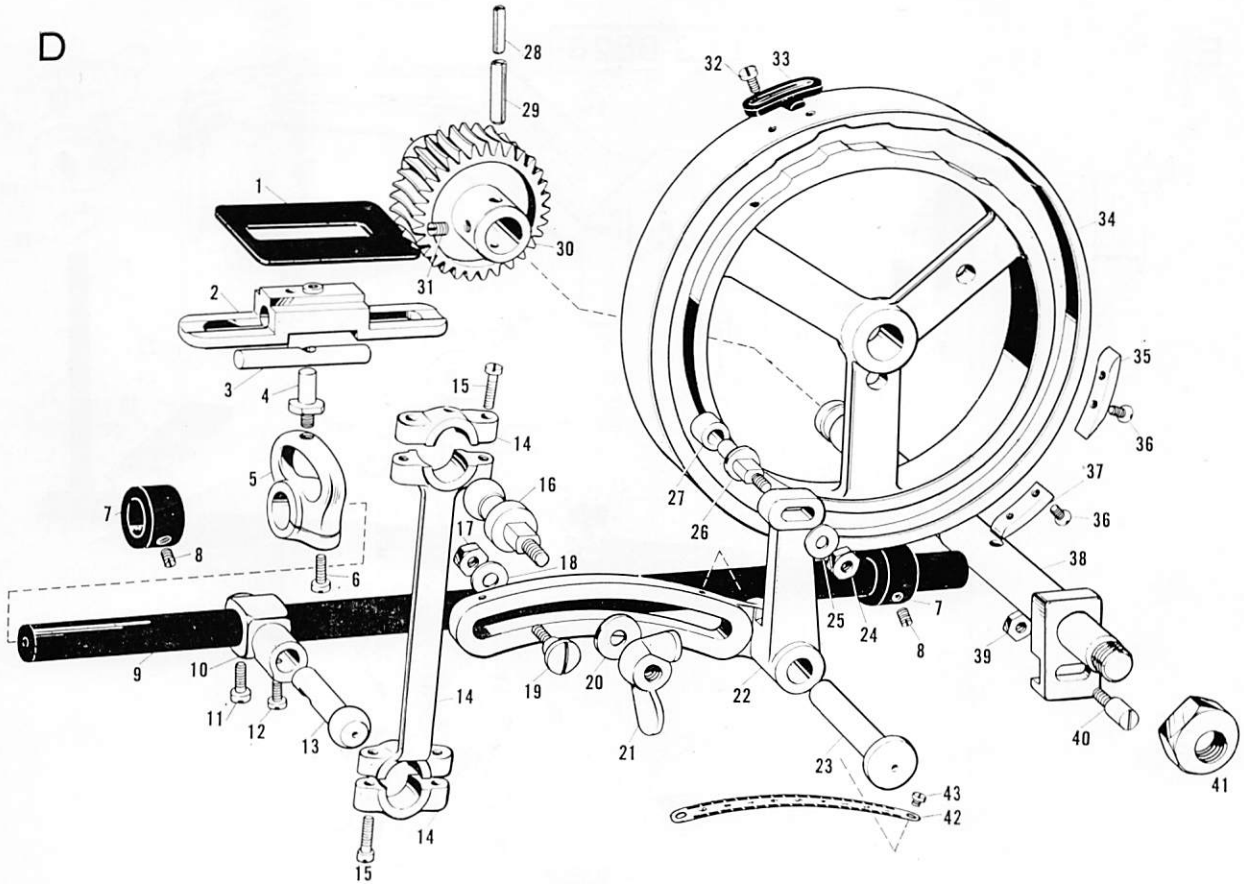

Ref. No.	Name of parts	Q'ty	Parts No.	Assembly No.	Ref. No.	Name of parts	Q'ty	Parts No.	Assembly No.
D-1	Feed Across Ring Cover	1 pce.	115502-0-01		D-28	Spring Pin 3×32	1 pce.	047302-2-42	
D-2	Feed Across Ring Guide	1 "	115500-0-01		D-29	Spring Pin 5×32	1 "	047503-2-42	
D-3	Feed Across Ring Guide Shaft	1 "	115501-0-01		D-30	Worm Wheel	1 "		
D-4	Feed Across Ring Stud	1 "	115499-0-01		D-31	Screw	1 "	014760-6-22	
D-5	Feed Across Ring	1 "	115498-0-01		D-32	Screw	2 pcs.	009670-5-13	
D-6	Screw	1 "	009711-4-13		D-33	Stop Tripping Segment	1 pce.	115451-0-01	
D-7	Collar	2 pcs.	115496-0-01		D-34	Feed Cam	1 "		
D-8	Screw	4 "	140557-0-01		D-35	Thread Nipper Tripping Segment (B)	1 "		
D-9	Feed Across Shaft	1 pce.	115495-0-01		D-36	Screw	4 pcs.	140555-0-01	
D-10	Ball Stud Bracket	1 "	115497-0-01		D-37	Thread Nipper Tripping Segment (A)	1 pce.		
D-11	Screw	1 "	009711-0-13		D-38	Worm Wheel Shaft	1 "	115448-0-01	
D-12	Screw	1 "	009680-7-13		D-39	Nut	1 "	021760-3-03	
D-13	Lower Ball Stud	1 "	115465-0-01		D-40	Stud Screw	1 "	115449-0-01	
D-14	Feed Across Rod	1 "	115462-0-01		D-41	Nut	1 "	105844-0-03	
D-15	Screw	4 pcs.	009681-4-14		D-42	Feed Across Indicator	1 "	142122-0-01	
D-16	Upper Ball Stud	1 pce.	115463-0-01	115461-0-01	D-43	Screw	2 pcs.	101275-0-04	
D-20	Washer	1 "	142216-0-01						
D-21	Wing Nut	1 "	115464-0-01						
D-17	Nut	1 "	021780-2-03						
D-18	Washer	1 "	025770-2-33						
D-19	Stud Screw	1 "	115389-0-01						
D-22	Feed Across Regulator	1 "	115456-0-01	115455-0-01					
D-24	Nut	1 "	107498-0-01						
D-25	Washer	1 "	025770-2-33						
D-26	Roller Stud	1 "	115457-0-01						
D-27	Roller	1 "	105872-0-01						
D-23	Feed Across Regulator Shaft	1 "	115460-0-01						

E

LK3-B826

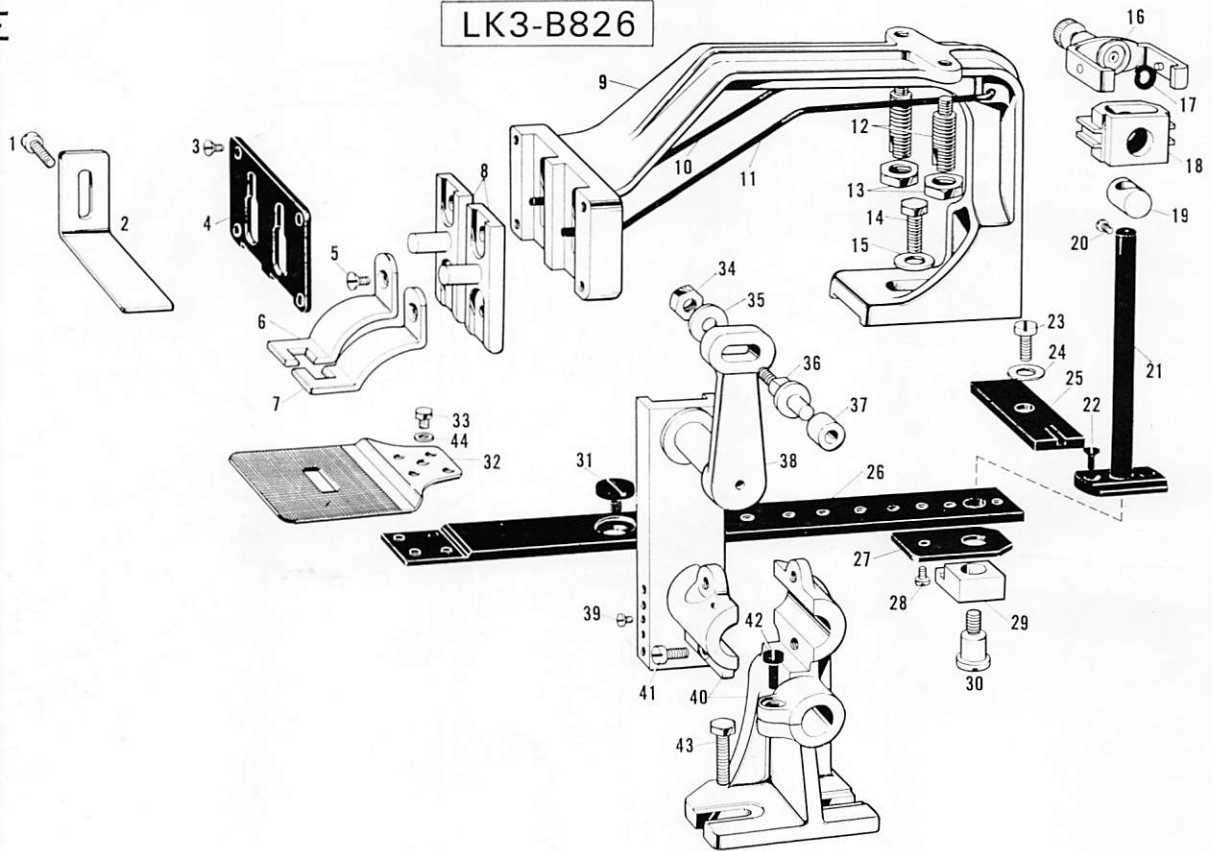

Ref. No.	Name of parts	Q'ty	Parts No.	Assembly No.	Ref. No.	Name of parts	Q'ty	Parts No.	Assembly No.
E- 1	Screw	2 pcs.	009710-7-13		E-17	Spring Washer	1 pce.	028050-2-40	
E- 2	Presser Arm Guide	1 pce.	115414-0-01		E-18	Feed Lengthwise Adjuster	1 "	115470-0-01	
E- 3	Screw	4 pcs.	107038-0-11		E-19	Screw	1 "	115471-0-01	
E- 4	Work Clamp Guide Plate	1 pce.	115482-0-11		E-23	Feed Lengthwise Adjusting Shaft	1 "	009761-0-13	
E- 5	Screw	2 pcs.	117143-0-01		E-24	Washer	1 "	025060-2-33	
E- 6	Work Clamp (left)	1 pce.			E-25	Block Guide Plate	1 "	115494-0-01	
E- 7	Work Clamp (right)	1 "			E-31	Screw	1 "	115503-0-01	
E- 8	Work Clamp Set Plate	2 pcs.	115481-0-01		E-34	Nut	1 "	107498-0-01	
E- 9	Presser Arm	1 pce.	115477-0-01		E-35	Washer	1 "	025770-2-33	
E-10	Work Clamp Spring (left)	1 "	115484-0-11		E-36	Roller Shaft	1 "	115469-0-01	115466-0-01
E-11	Work Clamp Spring (right)	1 "	115483-0-01		E-37	Roller	1 "	105872-0-01	
E-12	Screw	2 pcs.	115485-0-01		E-38	Feed Lengthwise Regulator	1 "	115468-0-01	
E-13	Nut	2 "	100075-0-03		E-39	Screw	1 "	403865-0-01	
E-14	Bolt	1 pce.	017761-4-13		E-40	Feed Bracket	1 "	115467-0-01	
E-15	Washer	1 "	025770-2-33		E-41	Screw	2 pcs.	009711-0-13	
E-20	Screw	1 "	403865-0-01		E-42	Screw	1 pce.	013760-6-10	
E-21	Feed Regulator Post	1 "	115490-0-01		E-43	Bolt	2 pcs.	017761-6-13	
E-22	Screw	2 pcs.	102538-0-02						
E-26	Feed Plate Carrier	1 pce.	115486-0-01						
E-27	Set Plate	1 "	115491-0-01						
E-28	Screw	1 "	009670-6-13						
E-29	Feed Lengthwise Block	1 "	115492-0-01						
E-30	Stud Screw	1 "	115493-0-01						
E-32	Feed Plate	1 "							
E-33	Bolt	1 "	145831-0-01						
E-44	Washer	1 "							
E-16	Holder	1 "	115472-0-01						

F

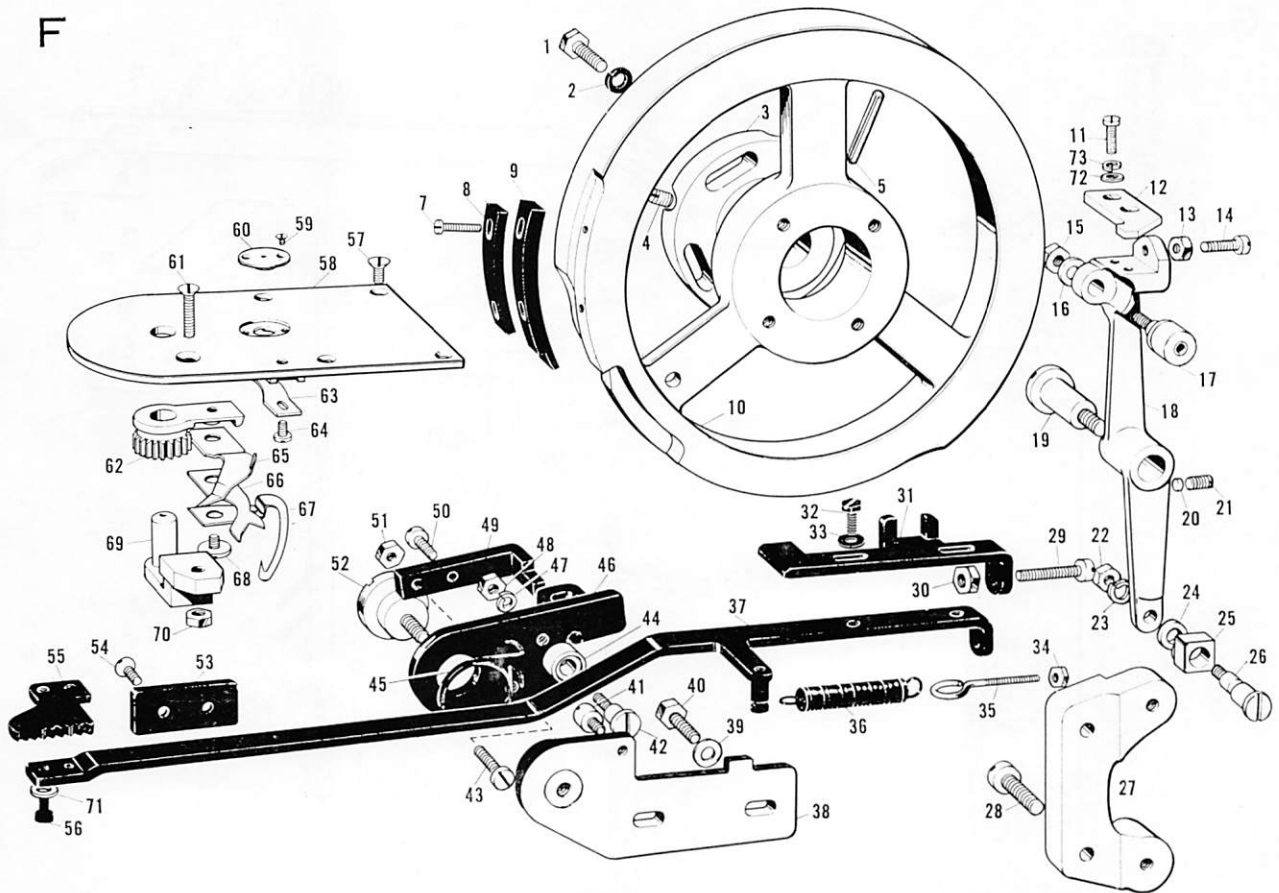

Ref. No.	Name of parts	Q'ty	Parts No.	Assembly No.	Ref. No.	Name of parts	Q'ty	Parts No.	Assembly No.
F- 1	Bolt	4 pcs.	017782-0-13		F-42	Stud Screw	1 pce.	115488-0-01	
F- 2	Spring Washer	4 "	028770-2-40		F-43	Screw	1 "	009681-4-13	
F- 3	Knife Cam Setting Plate	1 pce.	115454-0-01		F-44	Ball Block Operating Roller	1 "	115445-0-01	
F- 4	Screw	1 "	013760-8-10		F-45	Spring	1 "	115592-0-01	
F- 5	Spring Pin 5x32	1 "	047503-2-42		F-46	Knife Operating Lever	1 "	115408-0-01	
F- 7	Screw	2 pcs.	009661-4-12		F-47	Spring Washer	1 "	028050-2-40	116833-0-01
F- 8	Knife Guide (B)	1 pce.			F-48	Nut	1 "	021710-2-03	
F- 9	Knife Guide (A)	1 "			F-49	Knife Operating Lever Pawl	1 "	115415-0-01	
F-10	Knife Cam	1 "			F-50	Screw	1 "	009681-0-13	
F-11	Screw	2 pcs.	107732-0-01		F-51	Nut	1 "	021086-2-02	
F-12	Vertical Knife Lever Pawl	1 pce.			F-52	Stud Screw	1 "	115598-0-01	
F-13	Nut	1 "	022680-3-02		F-53	Guide Plate Knife Bar	1 "	115517-0-01	
F-14	Screw	1 "	009681-4-13	181004-0-01	F-54	Screw	2 pcs.	100032-0-04	
F-18	Vertical Knife Lever	1 "			F-37	Knife Bar	1 pce.	115511-0-01	
F-72	Washer	2 pcs.	105161-0-03		F-55	Knife Bar Rack	1 "	115512-0-01	
F-73	Spring Washer	2 "	028040-1-43		F-56	Screw	2 pcs.	009670-8-13	116834-0-01
F-15	Nut	1 pce.	021750-3-03		F-71	Washer	2 "	105161-0-03	
F-16	Washer	1 "	025750-2-33		F-57	Screw	4 "	100032-0-01	
F-17	Roller	1 "	180804-0-01		F-58	Needle Plate	1 pce.	105968-0-01	
F-22	Nut	1 "	021760-2-03		F-59	Screw	2 pcs.	105970-0-01	
F-23	Spring Washer	1 "	028060-2-40	116832-0-01	F-60	Needle Hole Insert	1 pce.		
F-24	Washer	1 "	115507-0-01		F-61	Screw	1 "	105955-0-01	
F-25	Vertical Knife Lever Slide Block	1 "	115506-0-01		F-62	Knife Carrier Position	1 "		
F-26	Stud Screw	1 "	115508-0-01		F-69	Pinion Stud Bracket Assembly	1 "		181021-0-01
F-19	Screw	1 "	115510-0-01		F-63	Fixed Knife	1 "	115582-0-01	
F-20	Washer	1 "	107793-0-00		F-64	Screw	1 "	105034-0-01	
F-21	Screw	1 "	013760-7-10		F-65	Lower Thread Cutting Knife	1 "	115578-0-01	
F-27	Vertical Knife Lever Bracket	1 "	115509-0-01		F-66	Upper Thread Cutting Knife	1 "	115581-0-01	
F-28	Screw	2 pcs.	009841-6-13		F-67	Thread Retainer	1 "	115474-0-01	
F-29	Screw	1 pce.	009762-0-13		F-68	Screw	1 "	105965-0-02	
F-30	Nut	1 "	022760-3-03		F-70	Nut	1 "	021680-2-02	
F-31	Knife Bar Adjusting Plate	1 "	115513-0-01						
F-32	Screw	2 pcs.	117363-0-01						
F-33	Washer	2 "	025710-1-32						
F-34	Nut	1 pce.	021670-2-03						
F-35	Hook	1 "	115516-0-01						
F-36	Knife Bar Pulling Spring	1 "	115603-0-01						
F-39	Washer	2 pcs.	025770-2-33						
F-40	Bolt	2 "	017781-4-13						
F-38	Guide Plate	1 pce.	115518-0-01						
F-41	Knife Motion Stopper	1 "	115601-0-01						

G

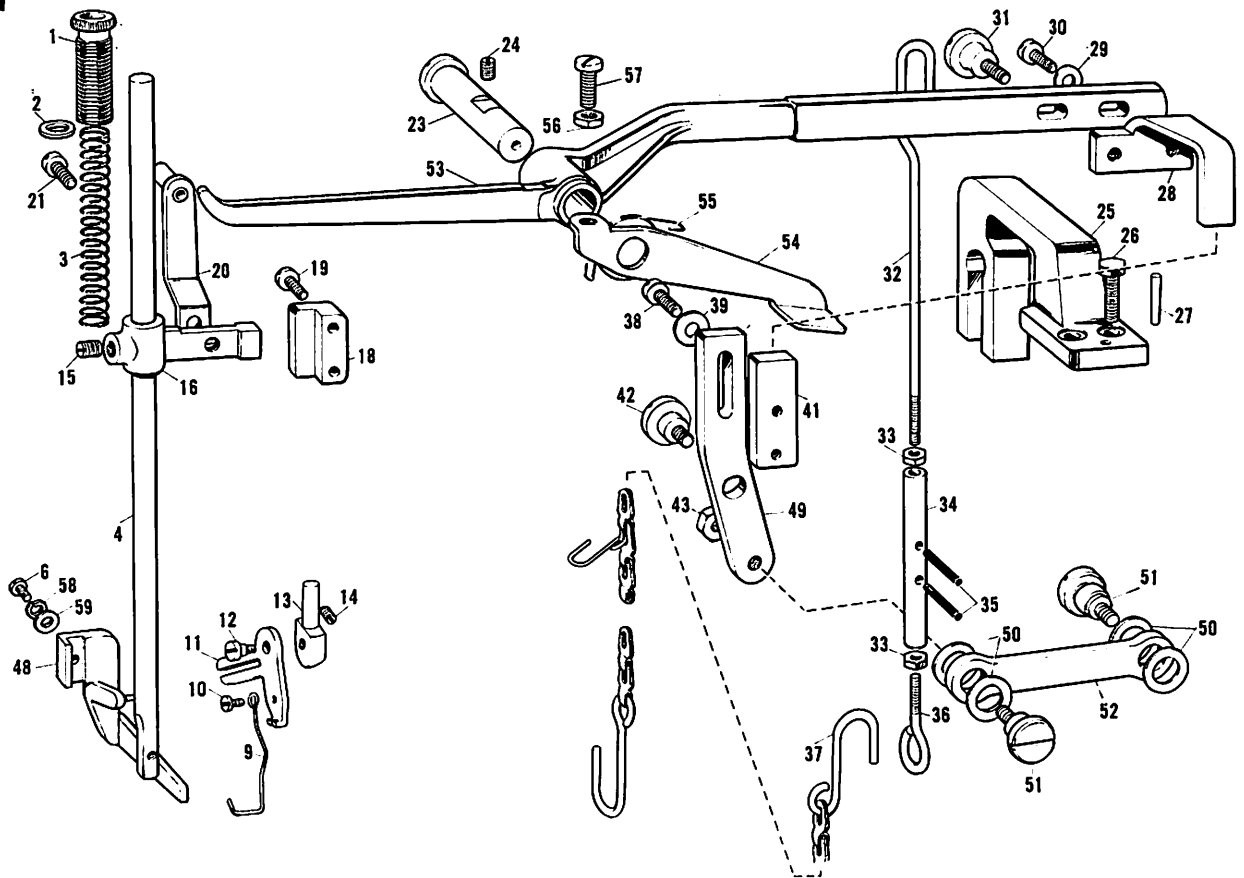

Ref. No.	Name of parts	Q'ty	Parts No.	Assembly No.	Ref. No.	Name of parts	Q'ty	Parts No.	Assembly No.
G- 1	Presser Adjusting Screw	1 pce.	100496-0-01		G-36	Hook	1 pce.	115537-0-01	
G- 2	Presser Spring Washer	1 "	141099-0-01		G-37	Lifting Lever Connecting Chain (A)	1 "	105333-0-01	
G- 3	Presser Spring	1 "	100280-0-01		G-38	Screw	2 pcs.	009761-2-13	
G- 4	Presser Bar	1 "	103013-0-01		G-39	Washer	2 "	025060-2-33	
G- 6	Screw	1 "	009671-0-13		G-41	Lifting Stop Lever Pawl	1 pce.	115534-0-01	
G- 9	Thread Reciprocater	1 "	115591-0-01		G-42	Stud Screw	1 "	115602-0-01	
G-10	Screw	1 "	009639-4-14		G-43	Nut	1 "	021760-2-02	
G-11	Thread Reciprocating Arm	1 "	115590-0-01	115589-0-01	G-48	Work Clamp Lifter Holder	1 "	118577-0-01	
G-12	Stud Screw	1 "	106011-0-01		G-49	Lifting Stop Lever	1 "	115533-0-01	
G-13	Thread Reciprocating Stud	1 "	106008-0-01		G-50	Washer	4 pcs.	118236-0-00	
G-14	Screw	1 "	013711-0-10		G-51	Stud Screw	2 "	115519-0-01	
G-15	Screw	1 "	013780-8-10		G-52	Lifting Stop Lever Connector	1 pce.	118235-0-01	
G-16	Presser Bar Guide	1 "	115521-0-01		G-53	Lifting Lever	11 "	115529-0-01	
G-18	Presser Bar Guide Plate	1 "	115525-0-01		G-54	Nipper Driver	1 "	118199-0-01	
G-19	Screw	2 pcs.	009681-2-13		G-55	Spring	1 "	118202-0-01	
G-20	Presser Bar Lifting Arm	1 pce.	115625-0-01		G-56	Nut	1 "	021760-3-03	
G-21	Screw	1 "	009710-7-13		G-57	Screw	1 "	009761-4-13	
G-23	Lifting Lever Guide Stud	1 "	115530-0-01		G-58	Spring Washer	1 "	028040-2-43	
G-24	Screw	1 "	014760-6-22		G-59	Washer	1 "	025350-3-33	
G-25	Lifting Lever Guide	1 "	115531-0-01						
G-26	Bolt	2 pcs.	017761-6-13						
G-27	Washer	2 "	028060-2-42						
G-28	Lifting Lever Stopper	1 pce.	115532-0-01						
G-29	Washer	1 "	025060-3-33						
G-30	Screw	1 "	009761-4-13						
G-31	Stud Screw	1 "	115514-0-01						
G-32	Presser Bar Connecting Bar	1 "	115458-0-01						
G-33	Nut	2 pcs.	021710-2-03						
G-34	Adjusting Rod	1 pce.	115459-0-01						
G-35	Spring Pin	2 pcs.	047302-2-42						

H

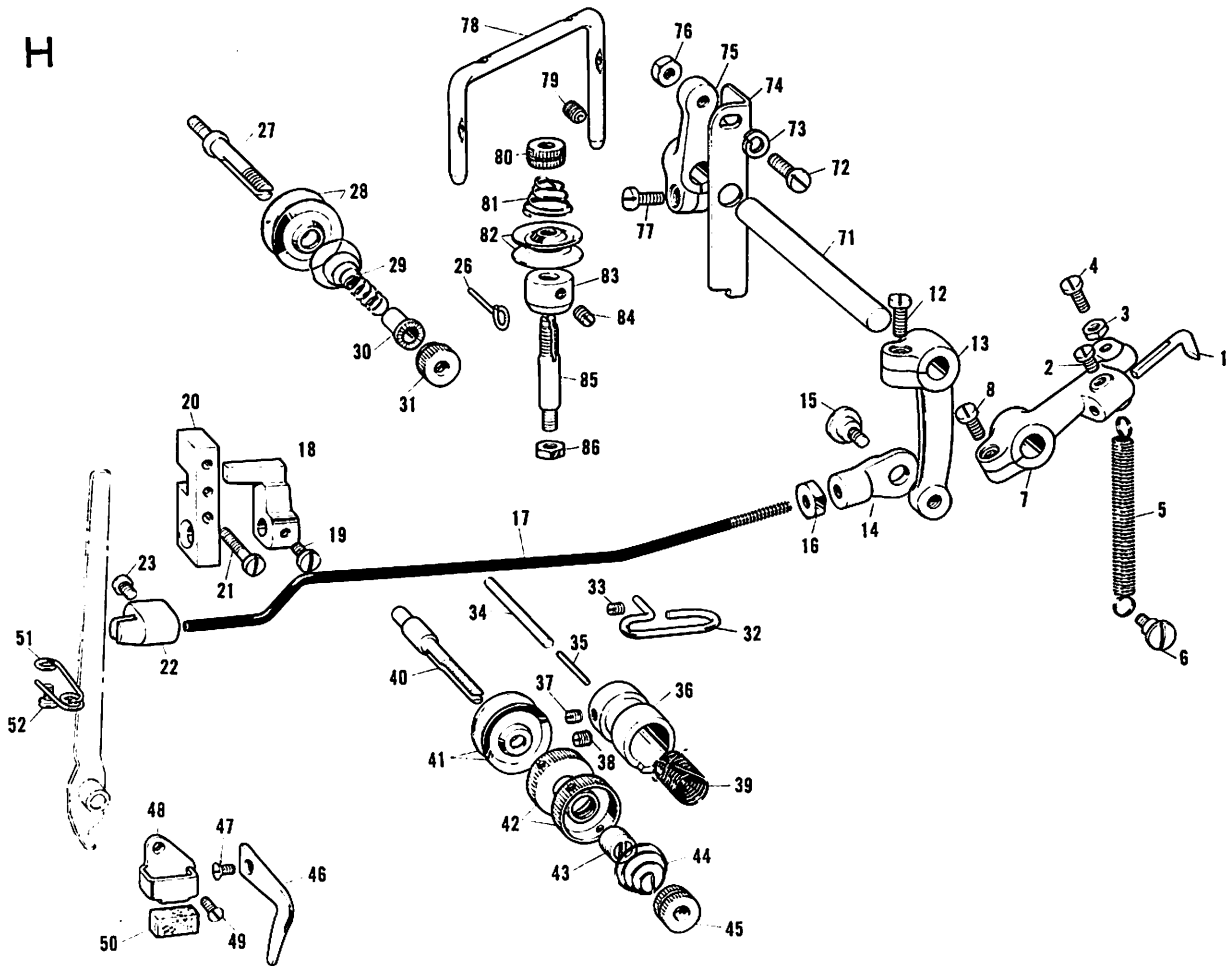

Ref. No.	Name of parts	Q'ty	Parts No.	Assembly No.	Ref. No.	Name of parts	Q'ty	Parts No.	Assembly No.
H- 1	Nipper Operating Lever Pawl	1 pce.	115407-0-01		H-44	Tension Spring	1 pce.		
H- 2	Screw	1 "	009680-6-13		H-45	Tension Control Nut	1 "	100136-0-01	180868-0-01
H- 3	Nut	1 "	021710-2-03		H-38	Screw	1 "	013760-8-10	
H- 4	Screw	1 "	009712-0-13		H-46	Thread Guide Plate	1 "	115595-0-01	
H- 5	Spring	1 "	115412-0-01		H-47	Screw	1 "	108960-0-03	
H- 6	Stud Screw	1 "	115559-0-01		H-48	Arm Thread Guide	1 "	117770-0-01	
H- 7	Nipper Operating Lever	1 "	115406-0-01		H-49	Screw	1 "	108960-0-03	
H- 8	Screw	1 "	009711-2-13		H-50	Felt	1 "	117771-0-01	
H-12	Screw	1 "	009711-2-13		H-51	Arm Thread Guide Lower	1 "	115610-0-01	
H-13	Nipper Operating Connecting Lever	1 "	115409-0-01		H-52	Screw	1 "	009660-6-13	
H-14	Joint	1 "	104842-0-01		H-71	Nipper Operating Lever Shaft	1 "	115410-0-01	
H-15	Stud Screw	1 "	106149-0-02		H-72	Screw	1 "	009711-4-13	
H-16	Nut	1 "	021710-2-03		H-73	Spring Washer	1 "	028050-2-40	
H-17	Nipper Operating Connecting Rod	1 "	115416-0-01		H-74	Nipper Adjusting Plate	1 "	118201-0-01	
H-18	Thread Tension Release	1 "	115419-0-01		H-75	Nipper Adjusting Lever	1 "	118200-0-01	
H-19	Screw	1 "	009670-4-13		H-76	Nut	1 "	021710-2-03	
H-20	Nipper Operating Connecting Rod Bracket	1 "	115418-0-01		H-77	Screw	1 "	009711-2-13	
H-21	Screw	2 pcs.	009671-6-13		H-78	Top Cover Thread Guide	1 "	118406-0-01	
H-22	Nipper Fasteng Plate Pusher	1 pce.	115417-0-01		H-79	Screw	1 "	013710-7-13	
H-23	Screw	1 "	009670-6-13		H-80	Tension Control Nut	1 "	100136-0-01	
H-26	Thread Guide	1 "	115606-0-01		H-81	Tension Spring	1 "	104525-0-01	
H-27	Sub Tension Stud	1 "	110820-0-01		H-82	Tension Disc	2 pcs.	108721-0-01	
H-28	Tension Disc	2 pcs.	108721-0-01		H-83	Tension Stud Collar	1 pce.	118405-0-01	
H-29	Sub Tension Spring	1 pce.	115958-0-01		H-84	Screw	2 pcs.	100388-0-03	
H-30	Sub Tension Washer	1 "	144105-0-00		H-85	Tension Stud	1 pce.	118404-0-01	
H-31	Sub Tension Control Nut	1 "	105230-0-01		H-86	Nut	1 "	021780-3-03	
H-32	Arm Thread Guide Upper	1 "	115571-0-01						
H-33	Screw	1 "	013660-6-10						
H-34	Tension Release Guide Pin	1 "	115600-0-01						
H-35	Thread Tension Release Pin	1 "	115599-0-00						
H-36	Thread Tension Bracket	1 "							
H-37	Screw	1 "	104649-0-01						
H-39	Check Spring	1 "							
H-40	Thread Tension Stud	1 "		180868-0-01					
H-41	Thread Tension Disc	2 pcs.							
H-42	Knob	1 pce.							
H-43	Screw	1 "							

LK3-B828

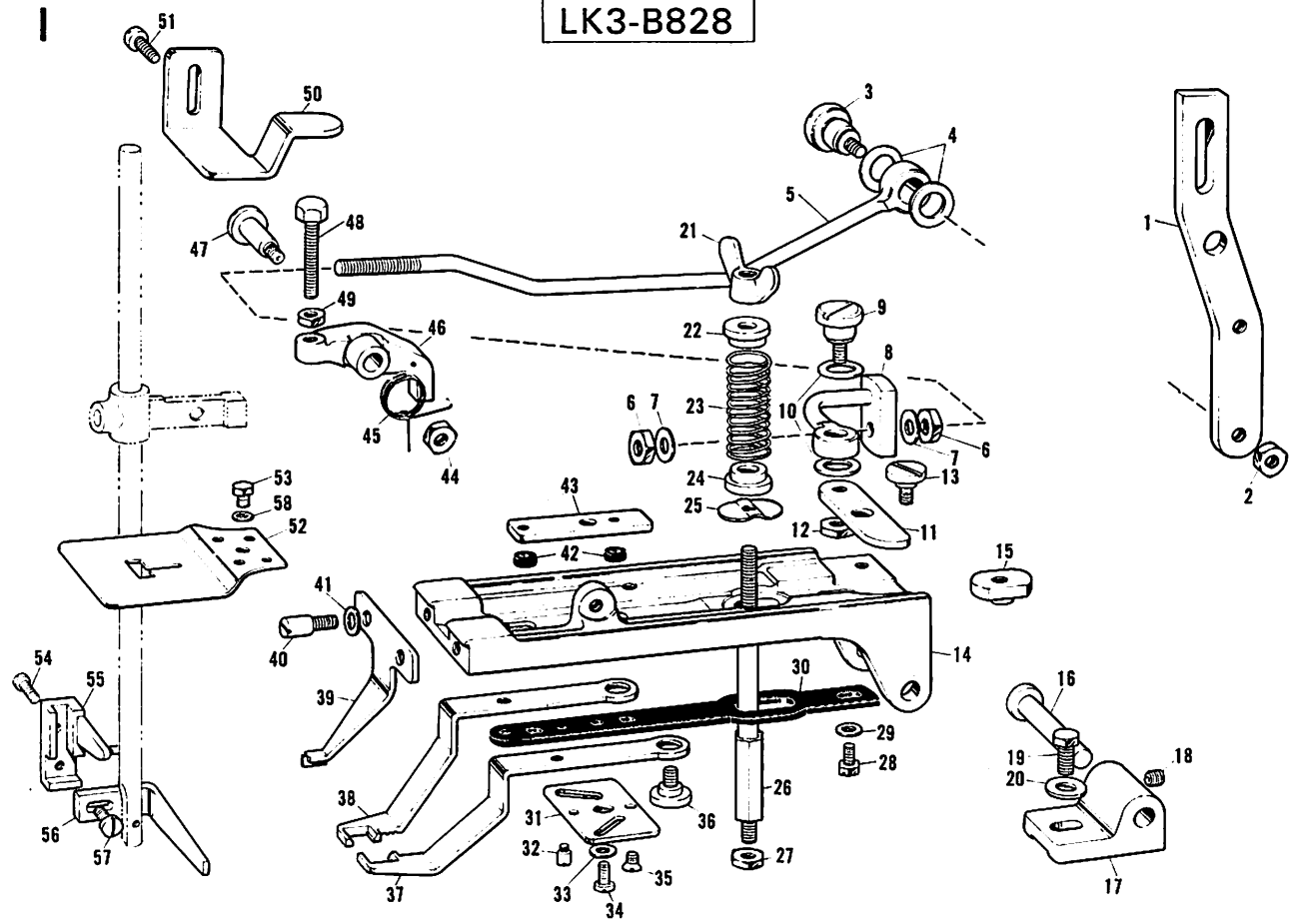

Ref. No.	Name of parts	Q'ty	Parts No.	Assembly No.	Ref. No.	Name of parts	Q'ty	Parts No.	Assembly No.
1-1	Lifting Stop Lever	1 pce.	118237-0-01		1-35	Screw	2 pcs.	117143-0-01	
1-2	Nut	1 "	021760-2-02		1-36	Stud Screw	2 "	118244-0-01	
1-3	Stud Screw	2 pcs.	115519-0-01		1-37	Work Clamp (Right)	1 pce.	118249-0-01	118314-0-01
1-4	Washer	2 "	118236-0-00		1-38	Work Clamp (Left)	1 "	118250-0-01	With Ref. No.
1-5	Work Clamp Connecting Bar	1 pce.	118238-0-01		1-39	Button Hole Guide	1 "	118253-0-01	E-20, E-21
1-6	Nut	2 pcs.	021760-2-03		1-40	Screw	2 pcs.	118254-0-01	E-22, E-26
1-7	Washer	2 "	025060-2-33		1-41	Washer	2 "	109763-0-01	E-27, E-28
1-8	Work Clamp Adjusting Bar	1 pce.	118239-0-01		1-42	Collar	2 "	118247-0-01	E-29, E-30
1-9	Stud Screw	1 "	115519-0-01		1-43	Stop Position Adjusting Plate	1 pce.	118248-0-01	
1-10	Washer	2 pcs.	118236-0-00		1-44	Nut	1 "	021760-3-03	
1-12	Nut	1 pce.	021760-2-02		1-45	Stop Lever Spring	1 "	118258-0-01	
1-11	Work Clamp Lever	1 "	118243-0-01		1-46	Stop Lever	1 "	118256-0-01	
1-13	Screw	1 "	118244-0-01		1-47	Stud Screw	1 "	118257-0-01	
1-14	Presser Arm	1 "	118240-0-01		1-48	Screw	1 "	118259-0-01	
1-15	Slide Block	1 "	118245-0-01		1-49	Nut	1 "	021680-3-03	
1-16	Presser Arm Holding Shaft	1 "	118242-0-01		1-50	Stop Lever Presser	1 "	118265-0-01	
1-17	Presser Arm Holder	1 "	118241-0-01		1-51	Screw	2 pcs.	009710-7-13	
1-18	Screw	1 "	013710-7-13		1-52	Feed Plate	1 pce.	118255-0-01	
1-19	Bolt	1 "	017761-2-13		1-53	Bolt	1 "	145831-0-01	
1-20	Washer	1 "	510032-0-01		1-54	Screw	1 "	009671-0-13	
1-21	Wing Nut	1 "	118262-0-01	118314-0-01	1-55	Work Clamp Bracket	1 "	115527-0-01	
1-22	Collar	1 "	118263-0-01	With Ref. No.	1-56	Work Clamp Lifter	1 "	115526-0-01	
1-23	Presser Spring	1 "	118260-0-01	E-20, E-21	1-57	Screw	1 "	009710-8-13	
1-24	Collar	1 "	118263-0-01	E-22, E-26	1-58	Washer	1 "	025710-1-32	
1-25	Washer	1 "	118264-0-01	E-27, E-28					
1-26	Presser Spring Adjusting Bar	1 "	118261-0-01	E-29, E-30					
1-27	Nut	1 "	021760-3-03						
1-28	Screw	1 "	117363-0-01						
1-29	Washer	1 "	025710-1-32						
1-30	Feed Plate Carrier	1 "	118246-0-01						
1-31	Work Clamp Guide Plate	1 "	118251-0-01						
1-32	Screw	2 pcs.	118252-0-01						
1-33	Washer	2 "	025710-1-32						
1-34	Screw	2 "	009681-0-13						

Z

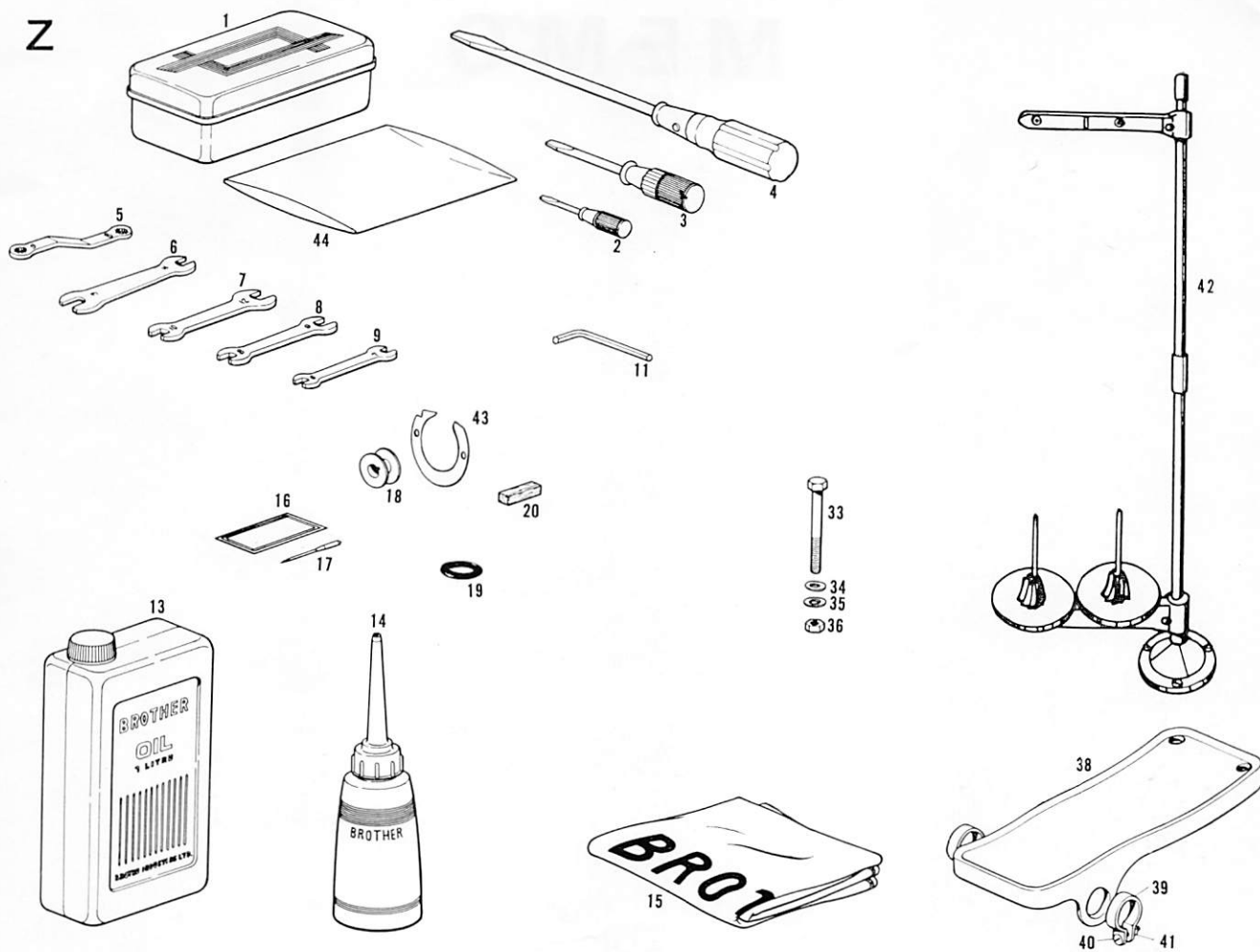

Ref. No.	Name of parts	Q'ty	Parts No.	Assembly No.	Ref. No.	Name of parts	Q'ty	Parts No.	Assembly No.
Z- 1	Accessory Box	1 pce.	110436-0-01		Z-35	Washer	4 pcs.	025060-3-32	
Z- 2	Screwdriver 2.6×40	1 "	122738-0-01		Z-36	Nut	4 "	021060-1-02	
Z- 3	Screwdriver 5.5×75	1 "	122739-0-01		Z-38	Foot Pedal	2 "	117437-0-01	
Z- 4	Screwdriver 6.4×204	1 "	100472-0-01		Z-39	Foot Pedal Stopper	2 "	116016-0-01	
Z- 5	Spanner 8×9	1 "	105343-0-01		Z-40	Screw	4 "	001401-4-16	
Z- 6	Wrench 14×17	1 "	116715-0-01		Z-41	Nut	4 "	021400-1-06	
Z- 7	Wrench 10×12	1 "	107780-0-01		Z-42	Cotton Stand	1 set.	142972-0-01	
Z- 8	Wrench 8×9	1 "	100887-0-01		Z-43	Shuttle Race Washer		112828-0-00	B826-(1.3A,3B,5A,5B),B828
Z- 9	Wrench 6×7	1 "	107779-0-01		Z-43	"		117426-0-00	B826-(1.3B,5B)
Z-11	Allen Wrench (3mm)	1 "	142721-0-01		Z-44	Head Cover	1 "	111196-0-01	
Z-13	Oil	1 "	145277-0-03						
Z-14	Oiler	1 "	114483-0-01						
Z-15	Head Cover	1 "	144226-0-01						
Z-16	Needle Bag	1 "	108920-0-01						
Z-17	Needle	5 pcs.							
Z-18	Bobbin	5 "	100117-0-01						
Z-19	Rubber Ring	1 pce.	120448-0-01						
Z-20	Felt	1 "	117771-0-01						
Z-33	Bolt	4 pcs.	144543-0-01						
Z-34	Washer	4 "	025060-2-32						

DIFFERENT PARTS LIST

Ref. No.	Name of parts	Sub-Class	LK3-B826-1	LK3-B826-3A	LK3-B826-3B	LK3-B826-5A	LK3-B826-5B	LK3-B828-A	LK3-B828-B
A-19	Model plate		143302001		143234001		143235001		143237001
B-11, Z-17	Needle		105771016	105771011	105771016	105771011	105771016		105771014
B-29	Worm		115420001		117502001		115420001	117502001	115420001
B-49	Shuttle race washer		117426000	117426000	117426000	117426000		117426000	
D-30	Worm wheel		115447001		117503001		115447001	117503001	115447001
D-32~D-37	Feed cam assembly		116830001		117489001		118272001	118277001	118272001
D-34	Feed cam		115450001		117490001		118205001	118207001	118205001
D-35	Thread nipper trippingsegment (B)		115568001		117492001		115568001	117492001	115568001
D-37	Thread nipper tripping segment (A)		115452001		117491001		115452001	117491001	115452001
E-3~E-33, E-44	Presser arm assembly		115476001		118530001		117524001		
E-6	Work clamp (left)		115479001		118532001		117498001		
E-7	Work clamp (right)		115478001		118531001		117497001		
E-32	Feed plate		115487001		118533001		117499001		
E-44	Washer		025710132		113431002		025710132		
F-7~F-10	Knife cam assembly		116830001	117493001	118273001	117493001	118273001	117493001	118273001
F-8	Knife guide (B)		115597001	117496001	115597001	117496001	115597001	117496001	115597001
F-9	Knife guide (A)		115596001	117495001	115596001	117495001	115596001	117495001	115596001
F-10	Knife cam		115453001	117494001	118206001	117494001	118206001	117494001	118206001
F-58~F-60	Needle plate assembly		182374001		182097001		182374001		182097001
F-60	Needle hole insert		118872001		105966000		118872001		105966000
Z-43	Shuttle race washer		1 pce.	2 pcs.	1 pce.	2 pcs.		1 pce.	

MEMO

MEMO

