

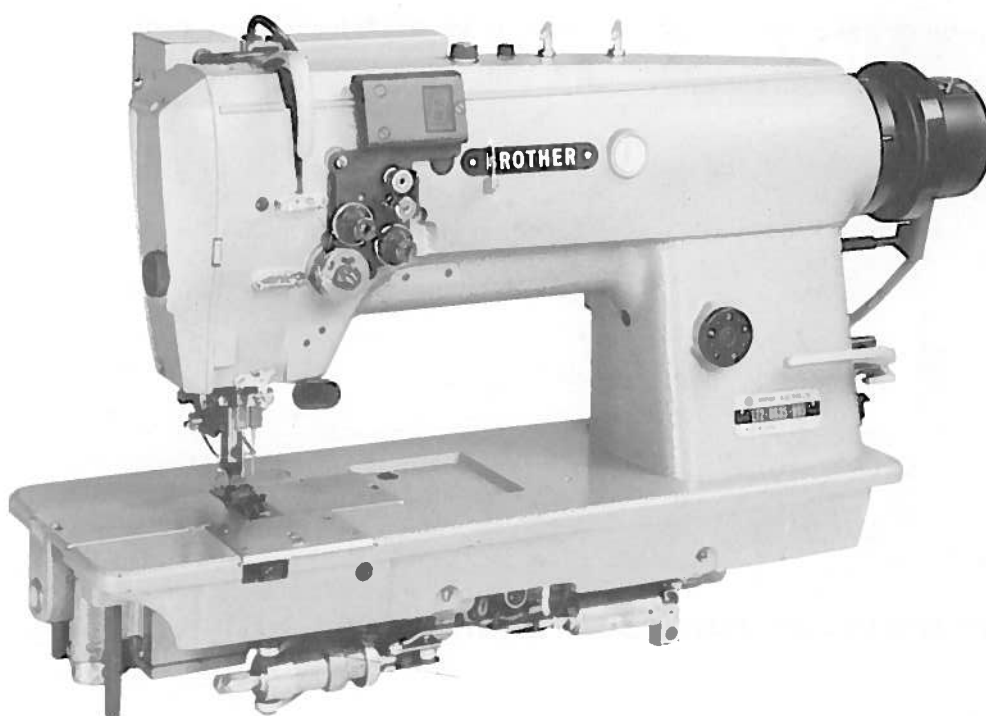

**PARTS BOOK**  
**FOR**  
**BROTHER LT2-B835-900**



**Twin Needle Needle Feed Automatic  
Corner Stitch Counting Machine**

**BROTHER INDUSTRIES, LTD.**  
**NAGOYA, JAPAN**

## Notes for using this parts book

1. If the symbol  is found in the "Parts No." column or the "Assembly No." column, refer to the different parts list on page 16.
2. The symbol  in the "Parts No." column indicates that the parts is not available for supply. If, however, there is a number in the "Assembly No." column, the parts can be ordered as an assembly. Please, therefore, order by using the assembly number.
3. This book was prepared based on information available in May, 1980.
4. Parts are subject to changes in design without prior notice.

## Anmerkungen zum Gebrauch dieses Stücklistebuches

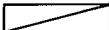
1. Dieses Zeichen  in der Spalte "Parts No. (Teilnummer)" oder "Assembly No. (Gerätesatznummer)" verweist auf die Gesonderte Stückliste auf Seite 16.
2. Dieses Zeichen  in der Spalte "Teilnummer" bedeutet, daß dieser Teil nicht lieferbar ist. Wenn jedoch in der Spalte "Gerätesatznummer" eine Nummer steht, kann dieser Teil als ein Geräteteilsatz bestellt werden. Bestellen Sie daher bitte mit dieser Gerätesatznummer.
3. Dieses Buch basiert auf den Informationen vom Mai 1980.
4. Modelländerungen sind vorbehalten.

## Notes sur l'utilisation de ce manuel de pièces détachées

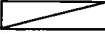
1. Si le symbole  se trouve dans la colonne "Parts No. (N° de pièce)" ou dans la colonne "Assembly No. (N° jeu de pces)", veuillez vous référer à la liste de pièces annexe page 16.
2. Le symbole  dans la colonne "N° de pièce" signifie que la pièce ne peut être fournie. Si, dans la colonne "N° jeu de pces", il y a un numéro de nomenclature, la pièce peut être commandée comme faisant partie d'un jeu de pièces. Donc, pour toute commande, veuillez spécifier le n° du jeu de pièces.
3. Ce manuel a été fait d'après les renseignements valables au mois de Mai 1980.
4. Les pièces peuvent être sujettes à des modifications sans préavis.

## Notas para usar este Libro de Piezas

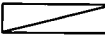
1. De haber un símbolo  junto al "Parts No. (Número de Pieza)" o en la columna del "Assembly No. (Número de Juego)", habrá que mirar la lista de piezas separada de la página 16.
2. El símbolo  , que se encuentra en la columna del "Número de Pieza", quiere decir que no se dispone de dicha pieza sola. Cuando, empero, hay un número en la columna del "Número de Juego", se podrá ordenar la pieza con todo el juego. Por lo tanto, será mejor hacer el pedido recurriendo al número del juego respectivo.
3. Este libro ha sido compilado basándose en los datos de que se disponía en mayo de 1980.
4. Las piezas quedan sujetas a cambios de diseño sin aviso previo.

## CONTENTS

A. Machine Body and Threading .....	1
B. Upper Shaft Mechanism .....	2
C. Needle Bar Rocking Mechanism .....	3
D. Needle Bar Flip-up Mechanism .....	4
E. Presser Foot Mechanism .....	5
F. Feed Mechanism .....	6
G. Lower Shaft and Rotary Hook Mechanism .....	7
H. Lubrication .....	8
J. Presser Foot Lifter, Reverse and Tension Release Mechanism .....	9
K. Thread Wiper and Reverse Switch Mechanism .....	10
L. Thread Trimmer and Tension Release Mechanism .....	11
M. Synchronizer Mechanism .....	12
N. Control Box Mechanism .....	13
P. Presser Foot Lifter Cord Mechanism .....	14
Z. Accessories .....	15
DIFFERENT PARTS LIST .....	16
GAUGE PARTS LIST .....	16
INDEX .....	17

# A. Machine Body and Threading

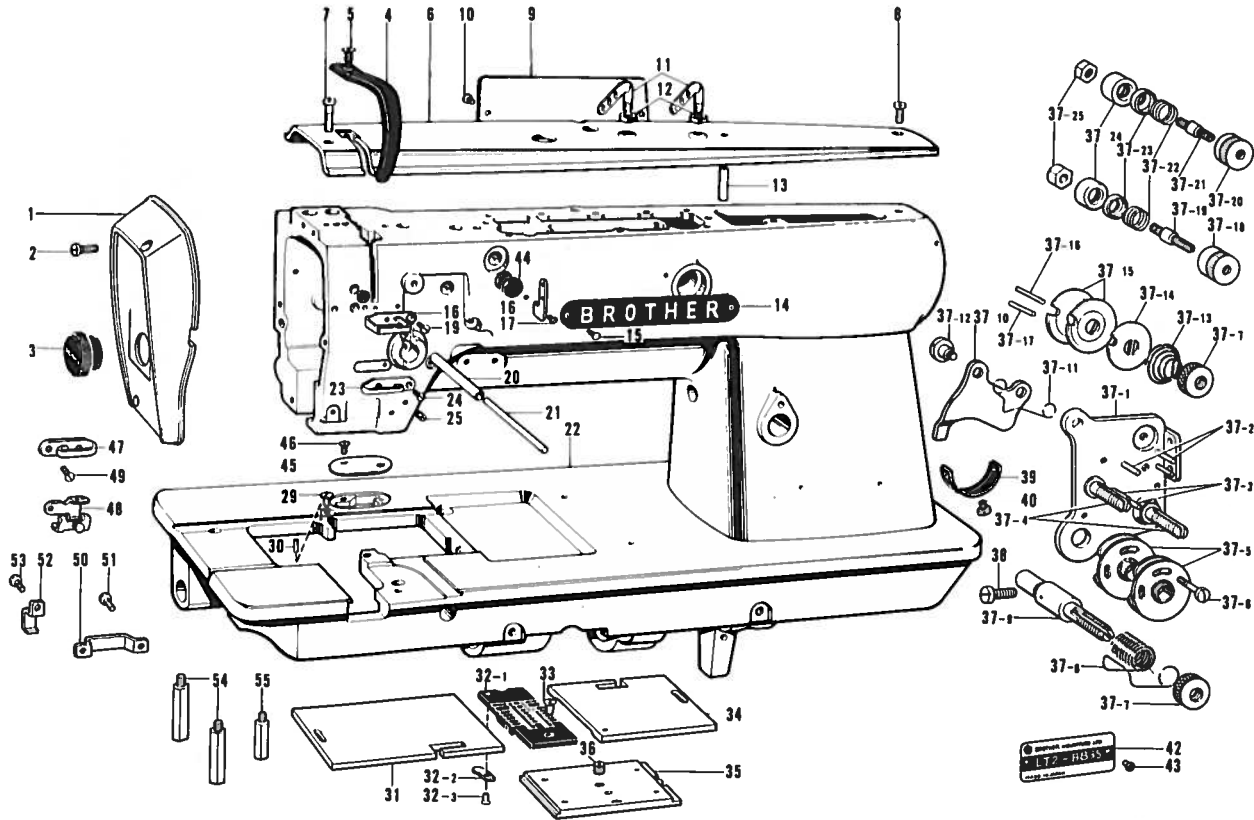

Ref. No.	Name of Parts	Q'ty	Parts No.	Assembly No.	Ref. No.	Name of Parts	Q'ty	Parts No.	Assembly No.
A-1	Face Plate	1	149819-0-03		A-37- 5	Spring Guide	2	108254-0-01	A-37 Tension Control Plate Assembly
A-2	Screw 3.57 x 8	2	009670-6-12		A-37- 6	Screw 2.38	1	144682-0-01	
A-3	Face Plate Cap	1	150815-0-01		A-37- 7	Tension Control Nut	3	108265-0-01	
A-4	Thread Take-up Cover	1	112561-0-02		A-37- 8	Thread Take-up Spring	1	144681-0-01	
A-5	Screw 4.76	1	107231-0-02		A-37- 9	Tension Stud	1	144680-0-01	
A-6	Arm Top Cover	1	112560-0-03		A-37-10	Tension Release Plate	1	144683-0-01	
A-7	Screw 4.37 x 16	1	009681-6-13		A-37-11	Tension Release Spring	1	118320-0-01	
A-8	Screw 4.37 x 10	1	009681-0-13		A-37-12	Screw 3.57	2	112712-0-01	
A-9	Rear Cover	1	112566-0-03		A-37-13	Tension Spring	2		
A-10	Screw 3.57 x 6	2	009670-6-12		A-37-14	Tension Disc Washer	2	148669-0-01	
A-11	Top Cover Thread Guide	2	140527-0-01		A-37-15	Tension Disc	4	108263-0-01	
A-12	Nut	2	150553-0-03		A-37-16	Tension Release Pin	1	148671-0-01	
A-13	Pipe	1	112696-0-00		A-37-17	Tension Release Pin	1	148670-0-01	
A-14	Name Plate "BROTHER"	1			A-37-18	Adjusting Screw (B)	1	148665-0-01	
A-15	Pin	2			A-37-19	Thread Guide Screw (B)	1	148663-0-01	
A-16	Thread Guide	1	149826-0-01		A-37-20	Adjusting Screw (A)	1	148664-0-01	
A-17	Screw 3.57	1	108960-0-04		A-37-21	Thread Guide Screw (A)	1	148662-0-01	
A-18	Arm Thread Guide Upper	1	108266-0-01		A-37-22	Thread Guide Spring	2	148668-0-01	
A-19	Screw 3.57	1	108960-0-04		A-37-23	Thread Guide Disc	2	148667-0-01	
A-20	Pipe	1	148604-0-00		A-37-24	Thread Guide Bracket	2	148666-0-01	
A-21	Tension Release Bar	1	148610-0-01		A-37-25	Nut	2	021670-1-02	
A-22	Arm Bed	1			A-38	Screw 3.57	1	100064-0-02	
A-23	Arm Thread Guide, Center	1	112658-0-01		A-39	Stopper	1	112709-0-01	
A-24	Screw 3.57	1	108960-0-04		A-40	Screw 3.57 x 6	1	009670-6-12	
A-25	Screw 4.37	2	151602-0-02		A-42	Model Plate	1		
A-29	Screw 3.57	1	112751-0-02		A-43	Pin	2		
A-30	Pin	1	113386-0-00		A-44	Oil Cap	1	153063-0-00	
A-31	Slide Plate, Left	1	112606-0-01		A-45	Cover	1	148614-0-01	
A-32-1	Needle Plate	1		A-32 Needle Plate Assembly 154507-0-01	A-46	Screw 3.18	2	149288-0-01	
A-32-2	Presser Spring for Fix Knife	2	148708-0-01		A-47	Arm Thread Guide, Center	1		
A-32-3	Pin	2	148709-0-01		A-48	Needle Thread Guide Assembly	1		
A-33	Screw 4.37	1	100032-0-03		A-49	Screw 3.57	1	108960-0-04	
A-34	Slide Plate, Right	1	112607-0-01		A-50	Cord Holder	1	148818-0-01	
A-35	Slide Plate Front Assembly	1	148599-0-01	A-51	Screw 3.57 x 6	2	009670-6-12		
A-36	Screw 5.16	1	116010-0-01	A-52	Tube Holder	3	142268-0-01		
A-37- 1	Upper Thread Tension Plate	1		A-37 Tension Control Plate Assembly	A-53	Screw 3.57 x 6	3	009670-6-12	
A-37- 2	Pin	3			A-54	Bed Leg	2	148611-0-01	
A-37- 3	Pin	2			A-55	Bed Leg, Small	1	149179-0-01	
A-37- 4	Tension Stud	2							

## B. Upper Shaft Mechanism

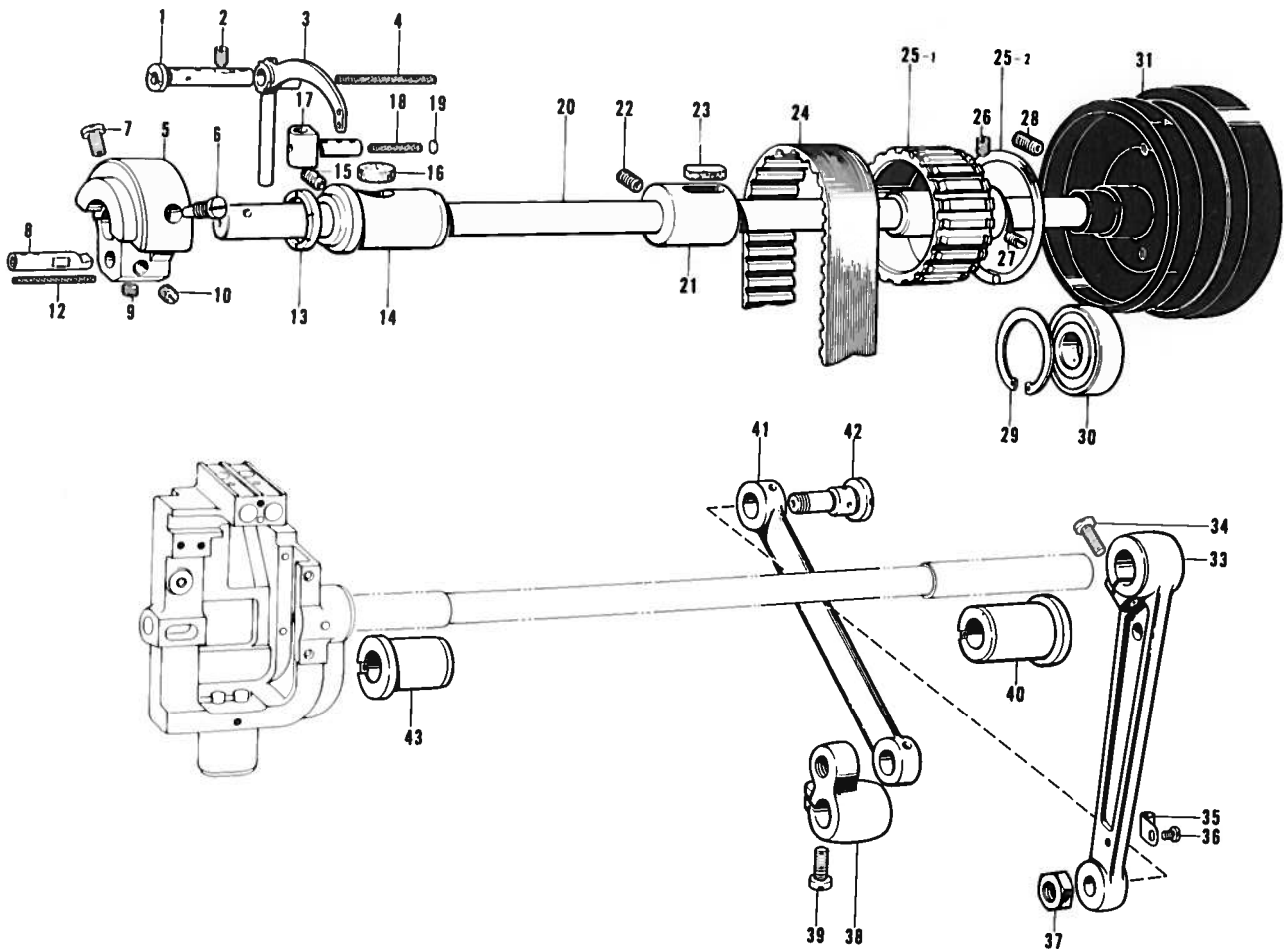

Ref. No.	Name of Parts	Q'ty	Parts No.	Assembly No.	Ref. No.	Name of Parts	Q'ty	Parts No.	Assembly No.
B- 1	Stud	1	149824-0-01		B-24	Timing Belt	1	112586-0-01	
B- 2	Screw 5.95	1	151605-0-01		B-25-1	Timing Belt Wheel Upper	1		B-25 Timing Belt Wheel Upper Assembly 180157-0-01
B- 3	Thread Take-up Lever	1	149823-0-01		B-25-2	Side Ring	2		
B- 4	Wick 3φ x 45	1	112735-0-01		B-26	Screw 6.35	1	015771-2-12	
B- 5	Counter Weight	1	149820-0-00		B-27	Screw 6.35	1	013771-2-12	
B- 6	Screw 7.14	1	100250-0-01		B-28	Screw 5.95	2	013761-4-10	
B- 7	Screw 7.14	1	146141-0-01		B-29	Stop Ring	1	112760-0-01	
B- 8	Needle Bar Crank	1	149821-0-01		B-30	Bearing 6204 VV.	1	072620-4-60	
B- 9	Screw 6.35	1	101706-0-01		B-31	Pulley	1	154506-0-01	
B-10	Screw 6.35	1	100251-0-01		B-33	Needle Bar Connecting Rod	1	112595-0-00	
B-12	Wick 3φ x 45	1	112735-0-00		B-34	Screw 6.35	1	105351-0-02	
B-13	Thrust Ring	1	112735-0-01		B-35	Wick Supporter	1	112739-0-01	
B-14	Upper Shaft Bushing, Left	1	112573-0-01		B-36	Screw 3.57 x 5	1	009670-5-12	
B-15	Screw 5.95	1	013761-4-10		B-37	Nut	2	101268-0-03	
B-16	Felt	1	112734-0-01		B-38	Needle Bar Connecting Crank	1	112598-0-01	
B-17	Thread Take-up Lever Slide Block	1	149825-0-01		B-39	Screw 6.35 x 18	1	009781-8-12	
B-18	Wick	1	114693-0-01		B-40	Needle Bar Rock Shaft Bushing, Right	1	112764-0-01	
B-19	Pusher	1	113024-0-00		B-41	Needle Bar Rock Link	1	112596-0-01	
B-20	Upper Shaft	1	112572-0-01		B-42	Needle Bar Rock Link Stud	2	112597-0-01	
B-21	Upper Shaft Bushing, Center	1	114680-0-01		B-43	Needle Bar Rock Shaft Bushing, Left	1	112594-0-01	
B-22	Screw 5.95	1	013761-4-10						
B-23	Felt	1	100248-0-01						

# C. Needle Bar Rocking Mechanism

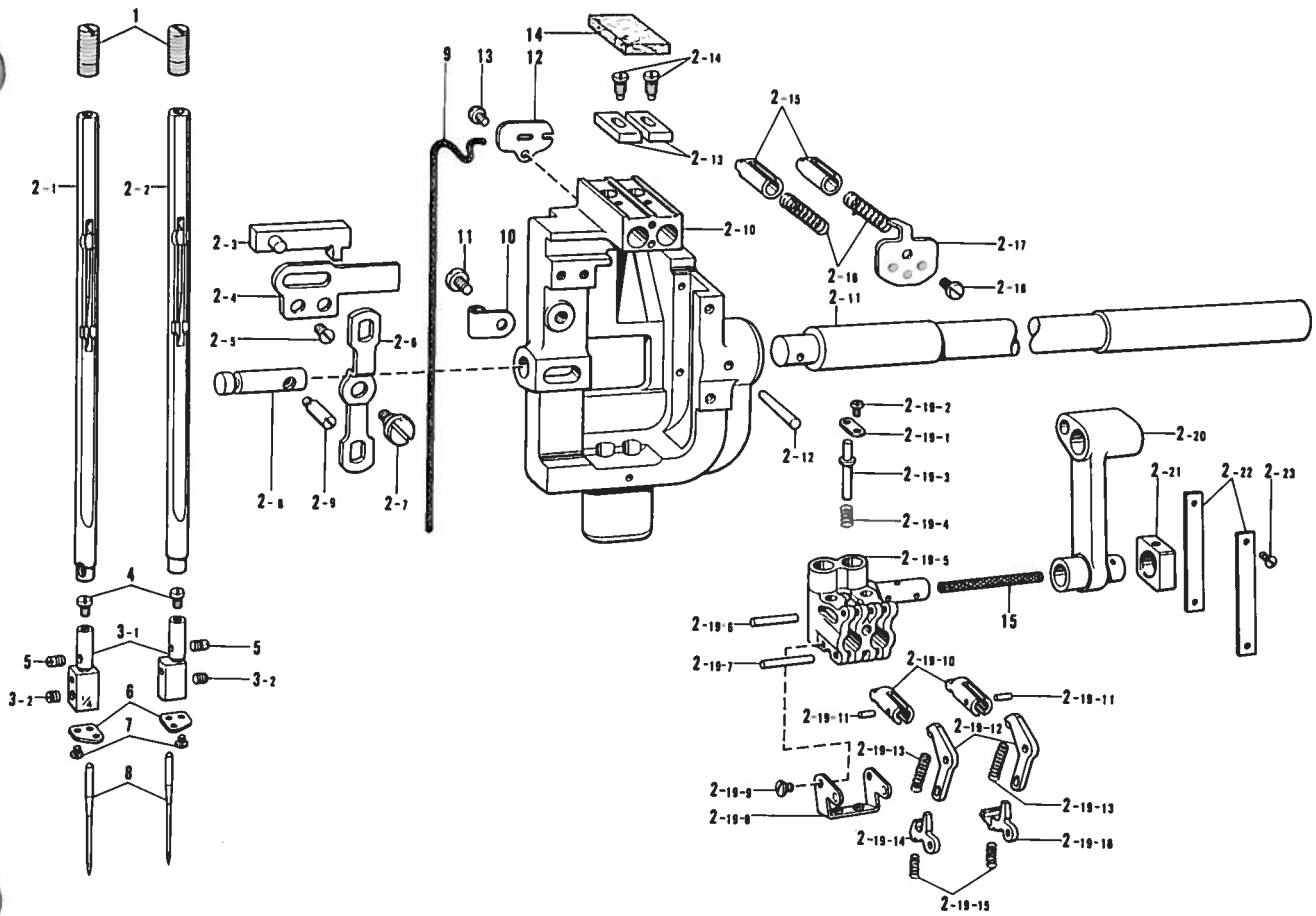

Ref. No.	Name of Parts	Q'ty	Parts No.	Assembly No.	Ref. No.	Name of Parts	Q'ty	Parts No.	Assembly No.
C- 1	Needle Bar Stopper Screw	2	150817-1-01		C- 2-19- 9	Screw 2.38	2	100105-0-02	
C- 2- 1	Needle Bar Left Assembly	1	*153604-0-01		C- 2-19-10	Clutch	2		
C- 2- 2	Needle Bar Right Assembly	1	*153606-0-01		C- 2-19-11	Pin	2	149604-0-01	
C- 2- 3	Slide Block Assembly	1	149618-0-01		C- 2-19-12	Clutch Lever	2		
C- 2- 4	Slide Block Guide Plate	1	149617-0-01		C- 2-19-13	Clutch Lever Spring	2	149605-0-01	
C- 2- 5	Screw 3.57	2	102843-0-01		C- 2-19-14	Clutch Stopper, Left	1	149606-0-01	
C- 2- 6	Slide Block Driving Lever	1	149616-0-01		C- 2-19-15	Slide Plate Stopper Spring	2	112609-0-01	
C- 2- 7	Screw 4.37	1	120264-0-01		C- 2-19-16	Clutch Stopper, Right	1	149607-0-01	
C- 2- 8	Slide Block Driving Stud	1	149614-0-01		C- 2-20	Needle Bar Crank Rod	1	149613-0-01	C-2
C- 2- 9	Screw	1	149615-0-01		C- 2-21	Needle Bar Guide Slide Block	1	150816-0-01	Needle Bar
C- 2-10	Needle Bar Support	1		C-2	C- 2-22	Guide Plate	2		Rock Shaft
C- 2-11	Needle Bar Rock Shaft	1		C-2	C- 2-23	Screw 2.38	4	102731-0-04	Assembly
C- 2-12	Pin	1	107030-0-01	C-2					150369-0-01
C- 2-13	Needle Bar Rotate Stopper	2	149624-0-01		C- 3-1	Needle Clamp	2		C-3
C- 2-14	Screw 3.18	2	149625-0-01		C- 3-2	Screw 3.18	2	013660-4-13	Needle Clamp
C- 2-15	Needle Bar Stopper	2	149621-0-01		C- 4	Screw 3.18	2	149831-0-01	with Screw
C- 2-16	Needle Bar Stopper Spring	2	149622-0-01		C- 5	Screw 3.18	2	149833-0-01	150830-0-01
C- 2-17	Spring Lid	1	149623-0-01		C- 6	Thread Guide Plate	2	149832-0-01	
C- 2-18	Screw 3.18 x 5	1	001660-5-12		C- 7	Screw 1.98	2	107404-0-00	
C- 2-19-1	Release Pin Cover	1	149612-0-01		C- 8	Needle DP x 5	2		
C- 2-19-2	Screw 2.38 x 3.5	1	001639-3-12		C- 9	Wick (ℓ = 340)	1	150374-0-00	
C- 2-19-3	Release Pin	1	149610-0-01		C-10	Wick Supporter	2	112739-0-01	
C- 2-19-4	Release Pin Spring	1	149611-0-01		C-11	Screw 3.57 x 5	2	009670-5-12	
C- 2-19-5	Needle Bar Clamp	1			C-12	Wick Cover	1	149626-0-01	
C- 2-19-6	Pin	1	149827-0-01		C-13	Screw 3.18 x 5	1	001660-5-12	
C- 2-19-7	Pin	1	149608-0-01		C-14	Felt	1	149834-0-00	
C- 2-19-8	Spring Holder	1	149609-0-01		C-15	Wick (ℓ = 35)	1	150825-0-01	

The parts Nos. marked by \* are only for spare parts order.

## D. Needle Bar Flip-up Mechanism

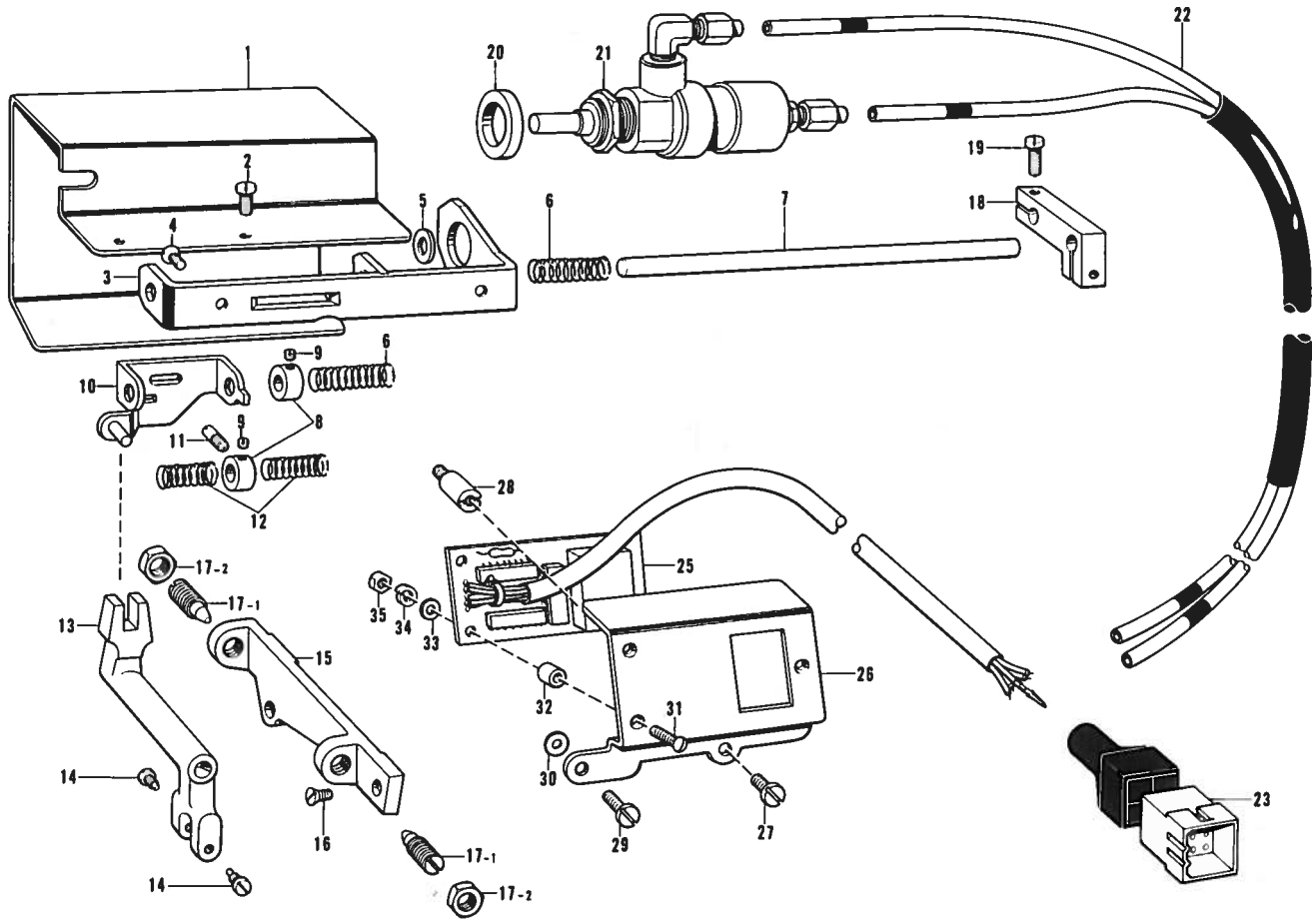

Ref. No.	Name of Parts	Q'ty	Parts No.	Assembly No.	Ref. No.	Name of Parts	Q'ty	Parts No.	Assembly No.
D- 1	Cylinder Cover	1	153073-0-01		D-18	Joint	1	153067-0-01	
D- 2	Screw 4.37 x 7	2	009680-7-12		D-19	Screw 3.57 x 10	2	009671-0-12	
D- 3	Slide Shaft Supporter	1	153064-0-01		D-20	Spacer	1	153068-0-01	
D- 4	Screw 4.37	2	107272-0-02		D-21	Needle Bar Disconnecting Cylinder Assembly	1	153069-0-01	
D- 5	Washer	2	118735-0-01		D-22	Air Tube Assembly	1	154491-0-01	
D- 6	Spring	2	153066-0-01		D-23	Nylon Connector 12P	1	153969-0-00	
D- 7	Slide Shaft	1	153065-0-01		D-25	Led Circuit Board	1	222773-0-01	
D- 8	Collar	2	149864-0-01		D-26	Led Mount	1	154498-0-01	
D- 9	Screw 3.57	3	011679-3-12		D-27	Screw 4.76 x 8	1	009710-8-13	
D-10	Slide Shaft Support Bracket Assembly	1	149860-0-01		D-28	Stud (S)	1	149853-0-01	
D-11	Guide Screw	1	149865-0-01		D-29	Screw 4.37 x 12	1	009681-2-14	
D-12	Spring	2	149863-0-01		D-30	Washer	1	110735-0-01	
D-13	Rock Crank	1	149868-0-01		D-31	Screw 3.57 x 14	3	151626-0-01	
D-14	Screw	2	100043-0-03		D-32	Spacer	3	154514-0-01	
D-15	Rock Crank Shaft Supporter	1	149867-0-01		D-33	Washer	3	105248-0-03	
D-16	Screw 4.37	2	107272-0-02		D-34	Washer	3	028350-2-42	
D-17-1	Taper Screw (Right) 7.14	2		D-17 Taper Screw Assembly 115638-0-04	D-35	Nut	3	021670-1-02	
D-17-2	Nut	2							



# E. Presser Foot Mechanism

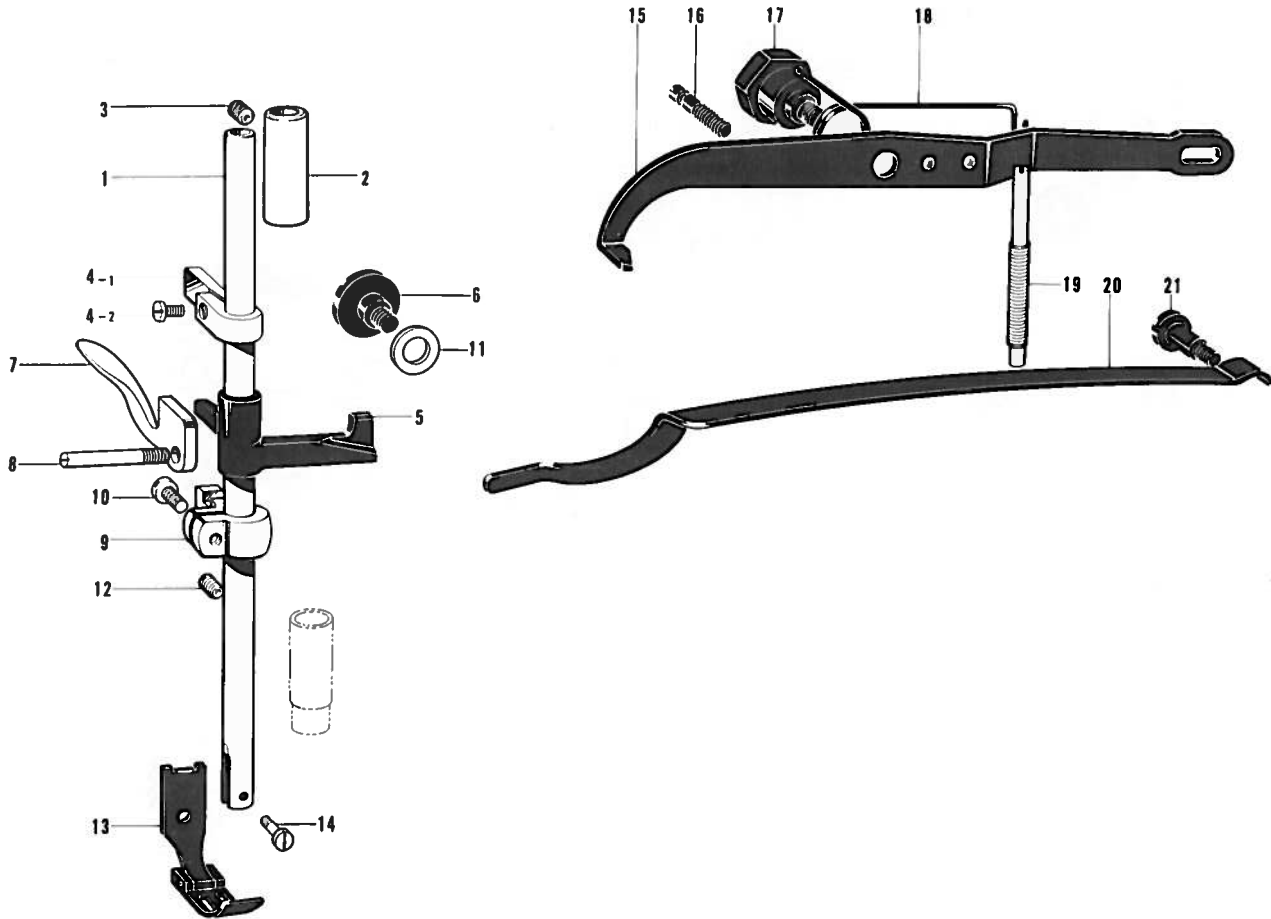

Ref. No.	Name of Parts	Q'ty	Parts No.	Assembly No.	Ref. No.	Name of Parts	Q'ty	Parts No.	Assembly No.
E- 1	Presser Bar	1	112614-0-01		E-11	Collar	1	148605-0-01	
E- 2	Presser Bar Bushing, Upper	1	112615-0-01		E-12	Screw 5.95	1	151604-0-01	
E- 3	Screw 5.95	1	100260-0-01		E-13	Presser Foot	1		
E- 4-1	Presser Bar Guide	1		E-4 Presser Bar Guide Assembly 148835-0-01	E-14	Screw 3.57	1	113050-0-01	
E- 4-2	Screw 4.37 x 7	1	009680-7-12		E-15	Knee Lifter Lever	1	148486-0-01	
E- 5	Presser Bar Lifter	1	148483-0-01		E-16	Stopper Screw	1	112630-0-01	
E- 6	Presser Bar Lifter Guide	1	112631-0-01		E-17	Screw 6.35	1	112626-0-01	
E- 7	Presser Foot Lifter	1	112618-0-01		E-18	Spring	1	149768-0-01	
E- 8	Screw	1	112619-0-01		E-19	Presser Adjusting Screw	1	112624-0-01	
E- 9	Presser Bar Bracket	1	112616-0-01		E-20	Presser Plate Spring	1	118170-0-01	
E-10	Screw 3.57 x 8	1	009670-8-12		E-21	Screw 6.35	1	112623-0-01	

# F. Feed Mechanism

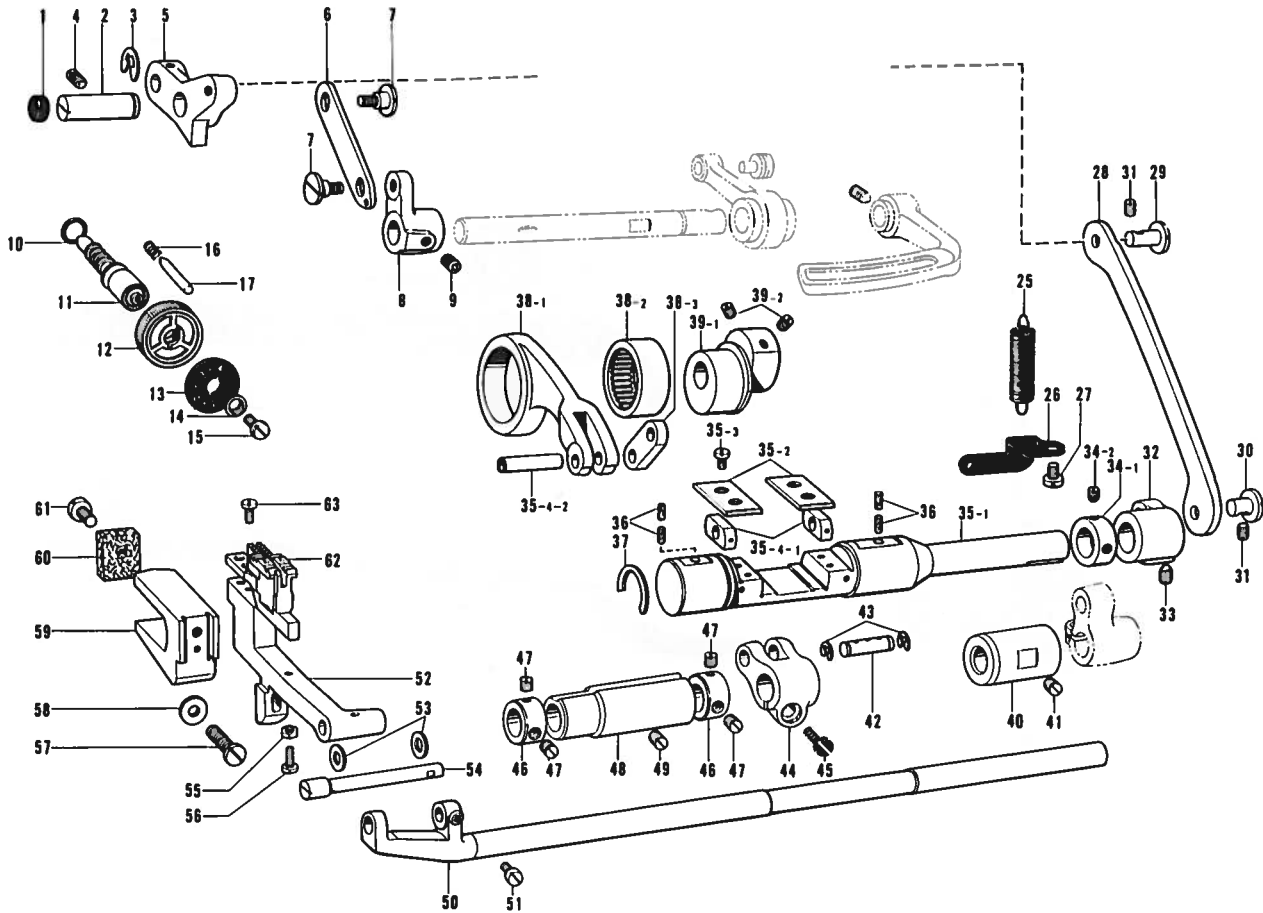

Ref. No.	Name of Parts	Q'ty	Parts No.	Assembly No.	Ref. No.	Name of Parts	Q'ty	Parts No.	Assembly No.
F- 1	Cap	1	143766-0-01		F-36	Felt	4	148743-0-01	
F- 2	Feed Regulator Stud	1	148488-0-01		F-37	Stop Ring	1	143597-0-01	
F- 3	Stop Ring	1	048070-3-42		F-38-1	Level Feed Connecting Rod	1	148496-0-00	F-38 Level Feed Connecting Rod Assembly 148801-0-01
F- 4	Screw 5.95	1	151605-0-01		F-38-2	Needle Bearing	1	118954-0-00	
F- 5	Feed Regulator	1	148489-0-01		F-38-3	Level Feed Connecting Link	1	143613-0-01	
F- 6	Connecting Plate	1	118746-0-01		F-39-1	Eccentric Wheel	1		F-39 Eccentric Wheel Assembly 148802-0-01
F- 7	Screw 4.37	2	112072-0-01		F-39-2	Screw 5.95	2	151605-0-01	
F- 8	Feed Regulator Bracket	1	118747-0-01		F-40	Feed Rock Shaft Bushing, Right	1	148493-0-01	
F- 9	Screw 5.95	1	118853-0-01		F-41	Screw 5.95	1	013761-4-10	
F-10	Packing	1	108549-0-01		F-42	Stud	1	143616-0-01	
F-11	Length Control Screw	1	143598-0-01		F-43	Stop Ring	2	048060-3-42	
F-12	Length Control Dial	1	153168-0-01		F-44	Level Feed Arm	1	148495-0-01	
F-13	Length Control Plate	1	151507-0-01		F-45	Screw 6.35 x 18	1	009781-8-12	
F-14	Length Control Supporter	1	142746-0-02		F-46	Collar	2	113074-0-01	
F-15	Screw 4.76	1	142747-0-02		F-47	Screw 6.35	4	101706-0-01	
F-16	Spring	1	100328-0-01		F-48	Feed Rock Shaft Bushing, Left	1	148494-0-01	
F-17	Pin	1	145502-0-01		F-49	Screw 5.95	1	013761-4-10	
F-25	Spring	1	143609-0-01		F-50	Feed Rock Shaft	1	148492-0-01	
F-26	Spring Hook Plate	1	143610-0-01		F-51	Screw 4.37	1	104908-0-04	
F-27	Screw 4.76 x 8	1	009710-8-12		F-52	Feed Bar	1	148490-0-01	
F-28	Feed Regulator Connecting Link	1	148487-0-01		F-53	Thrust Ring	2	143591-0-01	
F-29	Pin	1	118713-0-01		F-54	Feed Bar Shaft	1	148491-0-01	
F-30	Pin	1	148501-0-01		F-55	Nut	1	021660-1-03	
F-31	Screw 4.37	2	151602-0-01		F-56	Screw 3.18	1	107278-0-02	
F-32	Feed Regulator Arm	1	148500-0-01		F-57	Screw 5.95 x 14	1	009761-4-12	
F-33	Screw 5.95	1	118853-0-01		F-58	Washer	1	025060-1-32	
F-34-1	Collar	1		F-34 Collar Assembly 180321-0-01	F-59	Feed Bar Fork	1	112656-0-01	
F-34-2	Screw 6.35	2	101706-0-01		F-60	Felt	1	112759-0-01	
F-35-1	Feed Regulator Shaft	1		F-35 Feed Regulator Shaft Assembly 148771-0-01	F-61	Screw 3.57	1	100242-0-03	
F-35-2	Slide Block Guide Plate	2	143594-0-01		F-62	Feed Dog	1		
F-35-3	Screw 4.37 x 10	4	009681-0-12		F-63	Screw 3.18	2	116283-0-01	
F-35-4-1	Feed Regulator Slide Block	2		F-35-4 Slide Block 145328-0-01					
F-35-4-2	Feed Regulator Slide Block Shaft	1							

# G. Lower Shaft and Rotary Hook Mechanism

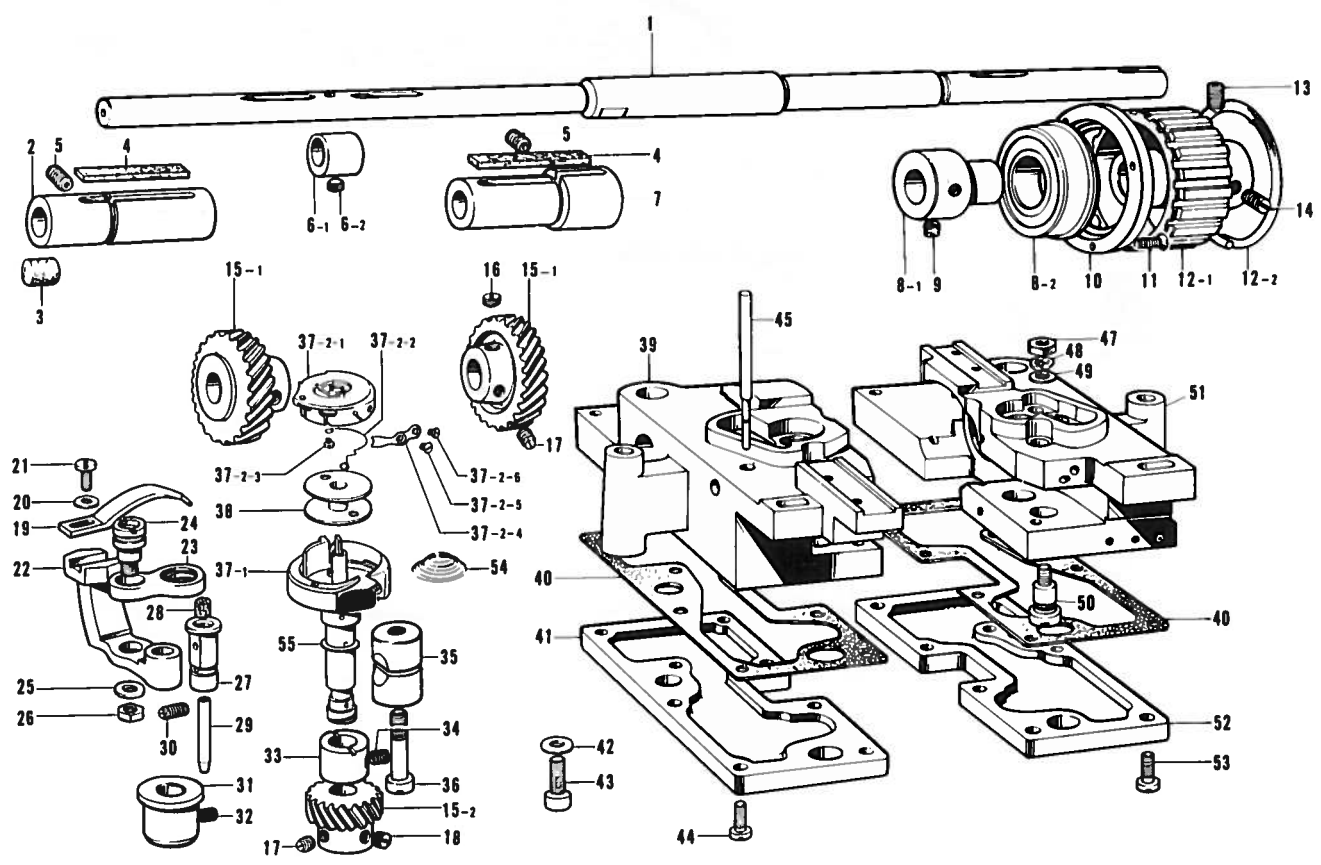

Ref. No.	Name of Parts	Q'ty	Parts No.	Assembly No.	Ref. No.	Name of Parts	Q'ty	Parts No.	Assembly No.	
G- 1	Lower Shaft	1	148505-0-01		G-28	Felt	2	107155-0-01		
G- 2	Rotary Hook Base Bushing, Left	1	148503-0-00		G-29	Pipe	1	112696-0-00		
G- 3	Felt	1	115249-0-01		G-30	Screw 4.76	2	153483-0-01		
G- 4	Felt	2	113362-0-01		G-31	Rotary Hook Shaft Bushing, Lower	2	112687-0-01		
G- 5	Screw 5.95	2	151604-0-01		G-32	Screw 4.76	2	107794-0-01		
G- 6-1	Vertical Feed Eccentric Wheel	1		G-6	Vertical Feed Eccentric Wheel Assembly	1				
G- 6-2	Screw 6.35	1	112684-0-01		G-33	Rotary Hook Shaft Bushing, Upper	2	112690-0-01		
G- 7	Rotary Hook Base Bushing, Right	1	148502-0-00		G-34	Screw 4.76	2	107794-0-01		
G- 8-1	Ball Bearing	1	112666-0-00	G-8	Bearing Holder Assembly 112698-0-01	G-35	Pinch Sleeve	2	112699-0-01	
G- 8-2	Bushing	1	112667-0-01		G-36	Screw 5.95	2	112700-0-01		
G- 9	Screw 6.35	2	013780-7-10		G-37-1	Outer Rotary Hook Assembly	2		G-37 Rotary Hook Assembly 150372-0-01	
G-10	Bearing Presser	1	112668-0-01		G-37-2-1	Bobbin Case	2		G-37-2 Bobbin Case Assembly 151044-0-01	
G-11	Screw 3.57 x 12	3	005671-2-12		G-37-2-2	Spring	2	151034-0-01		
G-12-1	Timing Belt Wheel Lower	1		G-12	Timing Belt wheel Lower Assembly 180164-0-01	G-37-2-3	Screw	2		151035-0-01
G-12-2	Ring	1			G-37-2-4	Tension Adjusting Spring	2	151043-0-01		
G-13	Screw 6.35	1	148821-0-01		G-37-2-5	Tension Adjusting Screw	2	151029-0-01		
G-14	Screw 6.35	1	013771-2-12		G-37-2-6	Screw	2	151030-0-01		
G-15-1	Spiral Gear	2		G-15	Spiral Gear Assembly 180949-0-01	G-38	Bobbin	2	148603-0-01	
G-15-2	Pinion	2			G-39	Rotary Hook Base, Left	1	148481-0-01		
G-16	Screw 6.35	2	112684-0-01		G-40	Packing	2	112755-0-01		
G-17	Screw 6.35	4	100251-0-01		G-41	Oil Reservoir, Left	1	112686-0-01		
G-18	Screw 6.35	6	101706-0-01		G-42	Washer	2	025770-2-32		
G-19	Bobbin Case Opener	2	112697-0-01		G-43	Bolt 6.35	2	149569-0-01		
G-20	Washer	2	105161-0-02		G-44	Screw 4.76	8	100320-0-02		
G-21	Screw 3.57 x 8	2	009670-8-12		G-45	Oil Gauge	2	148728-0-01		
G-22	Opener Crank	2	112694-0-01		G-47	Nut	2	105234-0-01		
G-23	Opener Link	2	112692-0-01		G-48	Washer	2	028680-2-43		
G-24	Opener Link Stud	2	148005-0-01		G-49	Washer	2	100645-0-03		
G-25	Washer	2	025710-2-32		G-50	Oil Adjusting Screw	2	112756-0-01		
G-26	Nut	2	110161-0-06		G-51	Rotary Hook Base, Right	1	148480-0-01		
G-27	Opener Crank Stud	2	112695-0-01		G-52	Rotary Hook Base Oil Reservoir, Right	1	112702-0-01		
					G-53	Screw 4.76	8	100320-0-02		
					G-54	Bobbin Tension Spring	2			
					G-55	Spacer 0.2	4	153243-0-01		
					G-55	Spacer 0.3	2	153244-0-01		

Basket ~~and~~ 151042-0-01  
 Assembly

# H. Lubrication

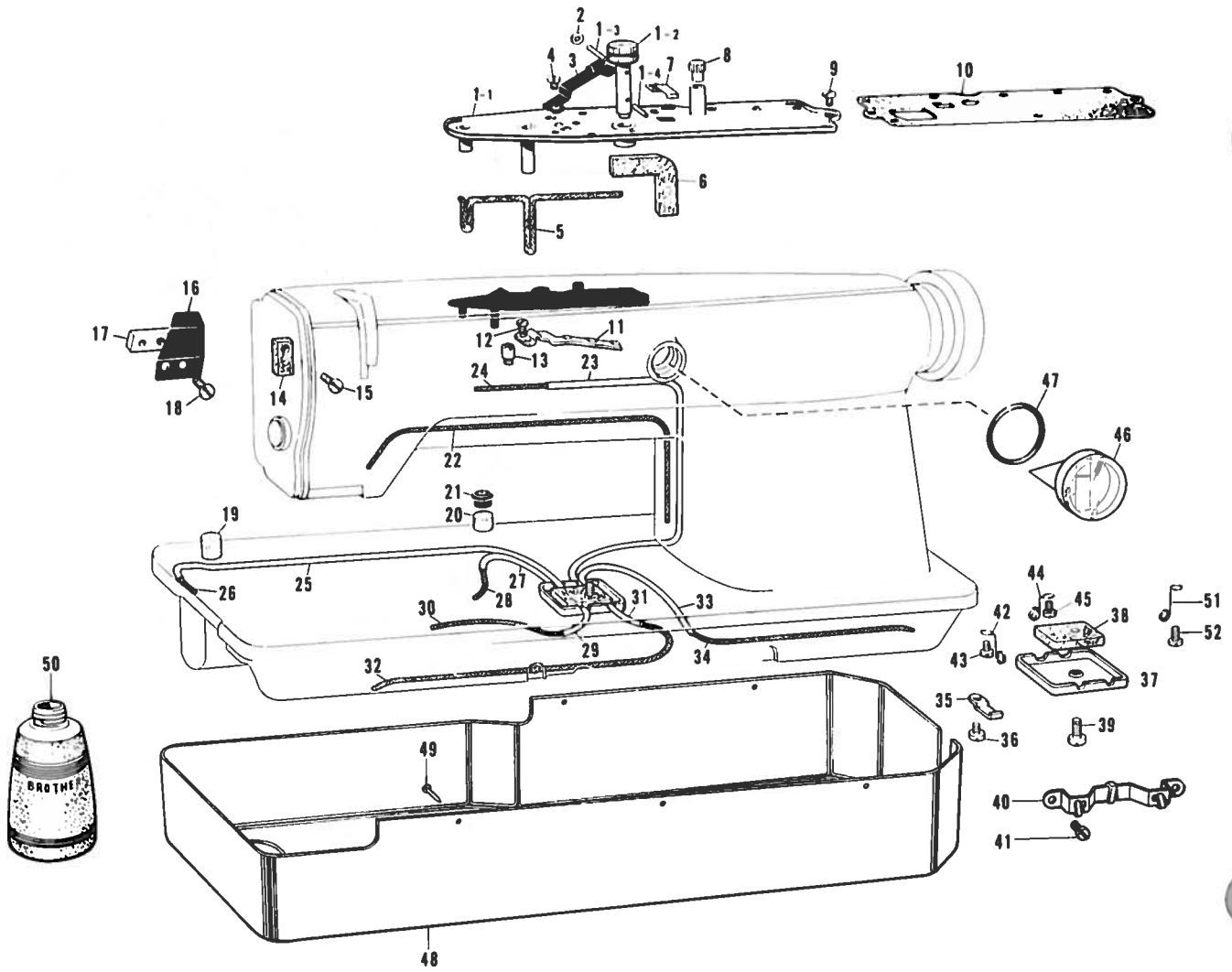

Ref. No.	Name of Parts	Q'ty	Parts No.	Assembly No.	Ref. No.	Name of Parts	Q'ty	Parts No.	Assembly No.
H- 1-1	Oil Reservoir Plate	1		H-1 Oil Reservoir Plate Assembly 112762-0-01	H-26	Wick 2.5φ x 375	1	148742-0-00	
H- 1-2	Oil Adjusting Knob	1			H-27	Oil Tube	1	148733-0-01	
H- 1-3	Pin	1			H-28	Wick 2.5φ x 160	1	148740-0-00	
H- 1-4	Pin	1			H-29	Oil Tube	1	148735-0-01	
H- 2	Washer	1	503093-0-01		H-30	Wick 2.5φ x 300	1	148736-0-00	
H- 3	Spring Plate	1	112730-0-01		H-31	Oil Tube	1	148737-0-01	
H- 4	Screw 3.57 x 3.5	1	009679-3-12		H-32	Wick 2.5φ x 335	1	148738-0-00	
H- 5	Wick	1	112725-0-01		H-33	Oil Tube	1	148733-0-01	
H- 6	Felt	1	112724-0-01		H-34	Wick 2.5φ x 310	1	148734-0-00	
H- 7	Felt Presser	1	114297-0-01		H-35	Felt Presser	2	114297-0-01	
H- 8	Cap for Oil Inlet	1	113526-0-01		H-36	Screw 3.57 x 5	2	009670-5-12	
H- 9	Screw 3.57 x 6	10	009670-6-12		H-37	Oil Tube Supporter	1	148729-0-01	
H-10	Packing	1	112723-0-01		H-38	Felt	1	148732-0-01	
H-11	Wick Supporter	1	143657-0-01		H-39	Screw 4.76 x 10	1	009711-0-12	
H-12	Screw 3.18	2	106640-0-01		H-40	Wick Support	1	143673-0-01	
H-13	Oil Tube Guide	1	113524-0-01		H-41	Screw 3.18 x 4	2	009660-4-12	
H-14	Felt	1	148762-0-01		H-42	Tube Holder	3	112743-0-01	
H-15	Screw 3.57 x 6	1	001670-6-12		H-43	Screw 3.57 x 5	3	009670-5-12	
H-16	Oil Stopper Plate	1	112716-0-01		H-44	Tube Holder	1	112744-0-01	
H-17	Oil Stopper Plate Presser	1	112717-0-01		H-45	Screw 3.57 x 5	1	009670-5-12	
H-18	Screw 4.76 x 8	1	009710-8-12		H-46	Oil Gauge Window	1	116558-0-01	
H-19	Felt	1	112754-0-01		H-47	"O" Ring	1	081016-0-70	
H-20	Felt	1	112753-0-01		H-48	Oil Pan	1	151007-1-01	
H-21	Oil Cap	1	112758-0-01		H-49	Nail	5	109714-0-00	
H-22	Wick 3φ x 440	1	112736-0-00		H-50	Oiler	1	114486-0-01	
H-23	Oil Tube	1	148730-0-01		H-51	Tube Holder	1	112745-0-01	
H-24	Wrick 2.5φ x 720	1	148731-0-00		H-52	Screw 3.75 x 5	1	009670-5-12	
H-25	Oil Tube	1	148741-0-01						

## J. Presser Foot Lifter, Reverse and Tension Release Mechanism

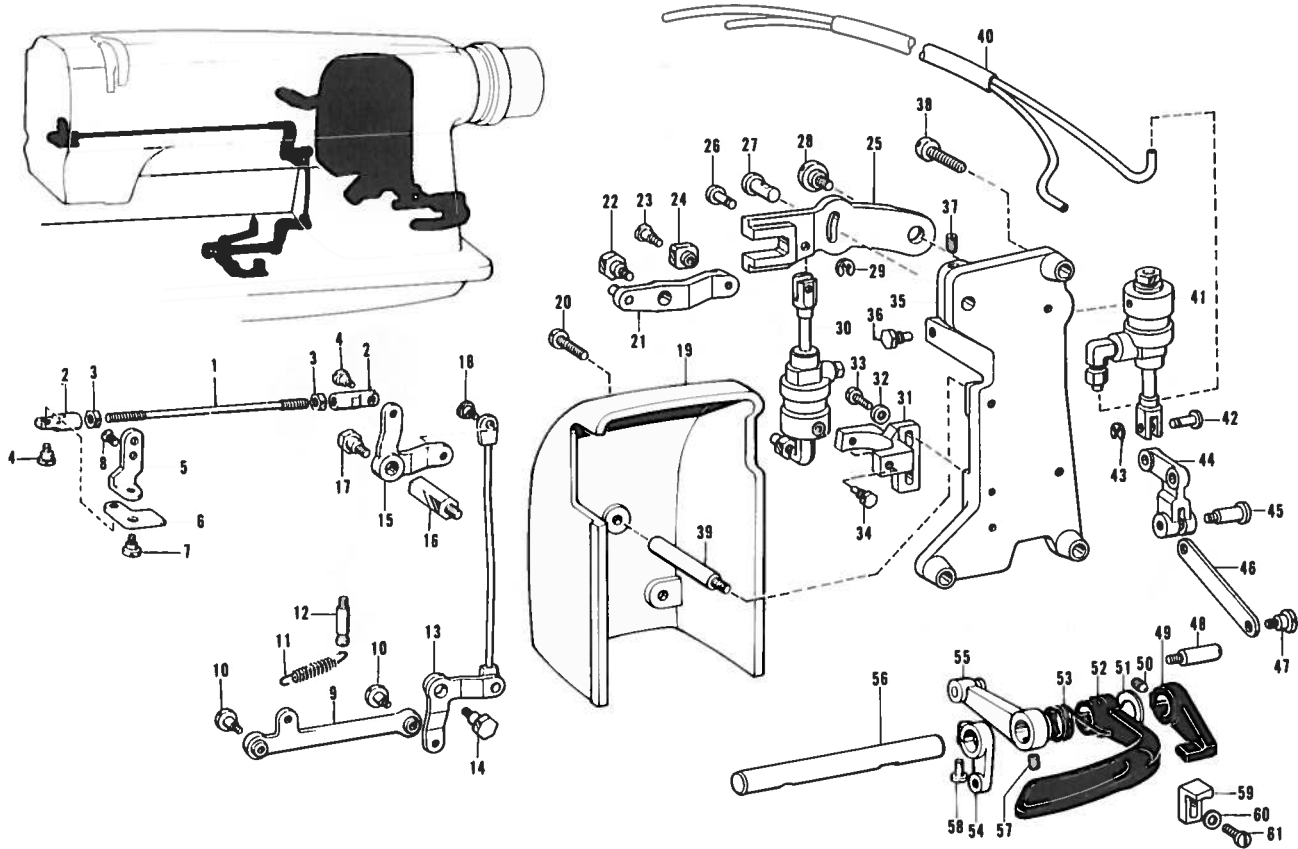

Ref. No.	Name of Parts	Q'ty	Parts No.	Assembly No.	Ref. No.	Name of Parts	Q'ty	Parts No.	Assembly No.
J-1	Tension Release Rod Upper	1	148631-0-01		J-32	Washer	2	025710-2-32	
J-2	Joint	2	148632-0-01		J-33	Screw 4.76 x 16	2	009711-6-12	
J-3	Nut	2	021670-1-02		J-34	Screw	2	140620-0-01	
J-4	Screw	2	148768-0-01		J-35	Cylinder Base	1	149030-0-01	
J-5	Tension Release Plate	1	148634-0-01		J-36	Screw	2	140620-0-01	
J-6	Tension Release Crank	1	148635-0-01		J-37	Screw 4.76	1	013710-7-12	
J-7	Screw 3.57	1	148633-0-01		J-38	Screw 6.35 x 25	3	009782-5-12	
J-8	Screw 4.37	2	117160-0-01		J-39	Cylinder Cover Stud	2	149034-0-01	
J-9	Tension Release Connecting Rod Lower	1	148623-0-01		J-40	Air Tube Assembly	1	149285-0-01	
J-10	Screw 4.37	2	123882-0-01		J-41	Reverse Cylinder	1	149031-0-01	
J-11	Spring	1	148654-0-01		J-42	Pin	1	146153-0-01	
J-12	Spring Hanger	1	115177-0-01		J-43	Stop Ring	1	048040-3-42	
J-13	Tension Release Crank Lower	1	148625-0-01		J-44	Reverse Link Lever	1	149033-0-01	
J-14	Screw 6.35	1	148628-0-01		J-45	Screw 4.76	2	148764-0-01	
J-15	Tension Release Crank Upper	1	148630-0-01		J-46	Reverse Link	1	149063-0-01	
J-16	Stud	1	148629-0-01		J-47	Screw 4.76	1	110171-0-01	
J-17	Screw 6.35	1	148628-0-01		J-48	Screw	1	141748-0-01	
J-18	Screw 4.76	1	110171-0-01		J-49	Reverse Lever (B)	1	148607-0-01	
J-19	Cylinder Cover	1	149035-0-01		J-50	Screw 6.35	1	015771-0-12	
J-20	Screw 4.76 x 12	2	009711-2-12		J-51	Thrust Ring	1	149554-0-01	
J-21	Lever Assembly	1	149027-0-01		J-52	Reverse Lever	1	148606-0-02	
J-22	Screw 6.35	1	149991-0-01		J-53	Spring	1	148608-0-01	
J-23	Screw	1	141494-0-01		J-54	Reverse Lever Shaft Arm	1	148640-0-01	
J-24	Slide Block Assembly	1	149025-0-01		J-55	Feed Regulator Link	1	148638-0-01	
J-25	Presser Foot Lifter Lever	1	149024-0-01		J-56	Reverse Lever Shaft	1	149609-0-01	
J-26	Pin	1	146153-0-01		J-57	Screw 5.95	1	014760-6-22	
J-27	Pin	1	118713-0-01		J-58	Screw 4.76 x 14	1	009711-4-12	
J-28	Screw 6.35	1	141439-0-01		J-59	Stopper	1	149282-0-01	
J-29	Stop Ring	1	048040-3-42		J-60	Washer	1	100645-0-03	
J-30	Presser Foot Lifter Cylinder	1	149019-0-01		J-61	Screw 4.37 x 10	1	009681-0-12	
J-31	Cylinder Supporter	1	149023-0-01						

## K. Thread Wiper and Reverse Switch Mechanism

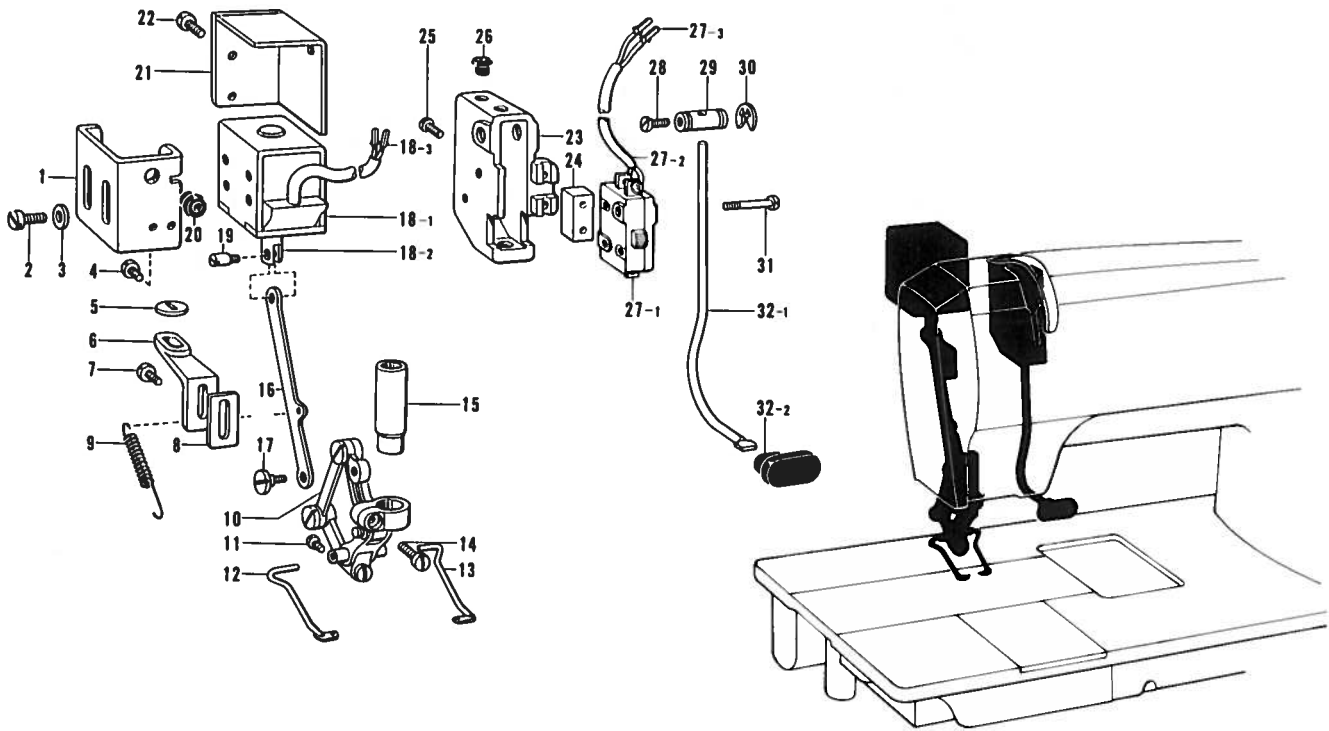

Ref. No.	Name of Parts	Q'ty	Parts No.	Assembly No.	Ref. No.	Name of Parts	Q'ty	Parts No.	Assembly No.
K- 1	Solenoid Bracket	1	148513-0-01		K-19	Plunger Pin	1	148546-0-01	
K- 2	Screw 4 x 10	4	007401-0-13		K-20	Bushing	1	146080-0-00	
K- 3	Washer	4	025040-2-33		K-21	Solenoid Cover	1	148514-0-01	
K- 4	Screw 4.37	2	107407-0-03		K-22	Screw 3.57 x 3.5	3	009679-3-12	
K- 5	Stopper	1	148518-0-00		K-23	Micro Switch Base	1	149870-0-01	
K- 6	Stopper	1	148516-0-01		K-24	Spacer	1	149873-0-01	
K- 7	Screw 4.37	2	107407-0-03		K-25	Screw 3.57 x 22	2	150824-0-01	
K- 8	Stopper	1	148517-0-00		K-26	Bushing	1	146080-0-00	
K- 9	Spring	1			K-27-1	Micro Switch	1		K-27 Switch 151884-0-00
K-10	Thread Wiper Link	1	148770-0-01		K-27-2	Reverse Switch Cord	1		
K-11	Screw	2	149177-0-01		K-27-3	Terminal Pin	2	143549-0-00	
K-12	Thread Wiper, Left	1	148530-0-01		K-28	Screw 4.37 x 14	1	009681-4-14	
K-13	Thread Wiper, Right	1	148529-0-01		K-29	Actuator Shaft	1	146125-0-01	
K-14	Screw 4.76 x 14	1	009711-4-13		K-30	Stop Ring	2	048080-3-42	
K-15	Presser Bar Bushing Lower	1	148508-0-01		K-31	Screw 2.38	2	146124-0-01	
K-16	Solenoid Link	1	148515-0-01		K-32-1	Actuator Bar	1	153074-0-01	K-32 Actuator Assembly 154509-0-01
K-17	Screw 3.18	1	148521-0-01		K-32-2	Actuator	1	146128-0-00	
K-18-1	Solenoid	1		K-18 Thread Wiper Solenoid Assembly 148509-0-01					
K-18-2	Plunger	1	148511-0-01						
K-18-3	Terminal Pin	2	143549-0-00						

# L. Thread Trimmer and Tension Release Mechanism

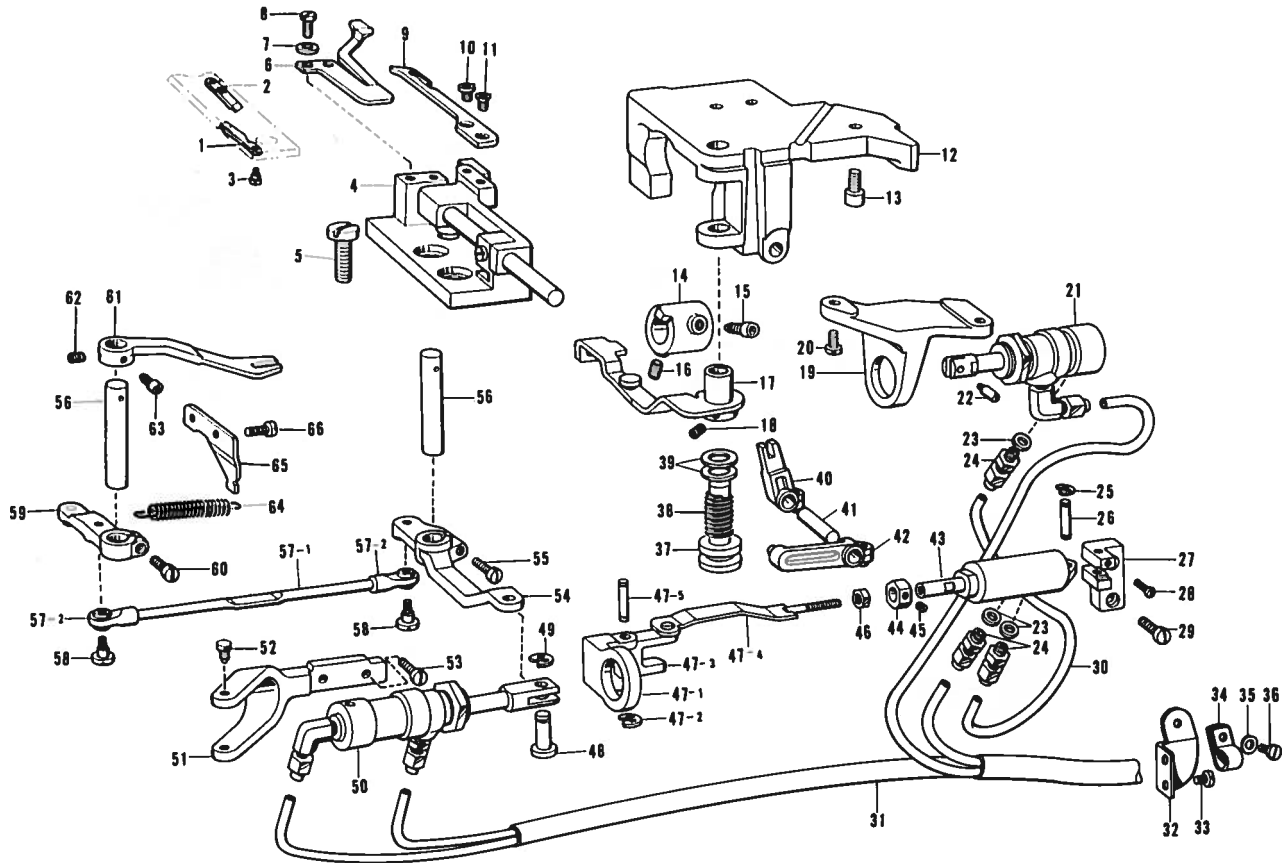

Ref. No.	Name of Parts	Q'ty	Parts No.	Assembly No.	Ref. No.	Name of Parts	Q'ty	Parts No.	Assembly No.
L-1	Fixed Knife, Left	1	148538-0-01		L-37	Knife Main Lever Shaft	1	148547-0-01	
L-2	Fixed Knife, Right	1	149169-0-01		L-38	Spring	1	148555-0-01	
L-3	Screw 2.38	2	148539-0-01		L-39	Rubber	2	148559-0-00	
L-4	Movable Knife Base Assembly	2	148531-0-01		L-40	Knife Driving	1	181713-0-01	
L-5	Screw 4.76 x 8	4	009710-8-12		L-41	Knife Driving Lever Shaft	1	148557-0-01	
L-6	Thread Presser Spring	2	150821-0-00		L-42	Knife Driving Pin Lever	1	181712-0-01	
L-7	Washer	4	025630-1-32		L-43	Transfer Cylinder	1	149052-0-01	
L-8	Screw 2.38 x 4	4	001630-4-02		L-44	Transfer Cylinder Nut	1	149281-0-01	
L-9	Movable Knife	2	148535-0-01		L-45	Screw 3.18	1	117666-0-01	
L-10	Screw 4.37	2	148536-0-01		L-46	Nut	1	021670-1-02	
L-11	Screw 4.37	2	148537-0-01		L-47-1	Valve Lever Supporter	1		
L-12	Movable Knife Base Bracket	1	149036-0-01		L-47-2	Stop Ring	2	048030-3-42	L-47 Valve Lever Assembly 149058-0-01
L-13	Bolt 6 x 16	3	018061-6-22		L-47-3	Valve Lever	1		
L-14	Tension Release Cam	1	149061-0-01		L-47-4	Valve Connecting Rod	1		
L-15	Screw 6.35	1	148574-0-01		L-47-5	Stud	1	149056-0-01	
L-16	Screw 6.35	1	014770-6-22		L-48	Pin	1	146153-0-01	
L-17	Tension Release Lever	1	149050-0-01		L-49	Stop Ring	1	048040-3-42	
L-18	Screw 6.35	2	014770-6-22		L-50	Thread Trimming Cylinder	1	149037-0-01	
L-19	Tension Release Cylinder Base	1	149049-0-01		L-51	Cylinder Supporter	1	149040-0-01	
L-20	Screw 4.76 x 10	2	009711-0-12		L-52	Screw	2	140620-0-01	
L-21	Tension Release Cylinder	1	149043-0-01		L-53	Screw 4.76 x 16	2	009711-6-12	
L-22	Plunger Pin	1	148546-0-01		L-54	Thread Trimming Lever	1	149042-0-01	
L-23	Packing	3	146699-0-00		L-55	Screw 4.76 x 14	1	009711-4-12	
L-24	Male Connector Assembly	3	149241-0-01		L-56	Knife Rock Arm Shaft	2	148573-0-01	
L-25	Stop Ring	1	048030-3-42		L-57-1	Knife Connecting Bar	1		L-57 Connecting Rod Assembly 148585-0-01
L-26	Stud	1	149056-0-01		L-57-2	Joint	2	148584-0-01	
L-27	Cylinder Supporter	1	149055-0-01		L-58	Screw	2	141494-0-01	
L-28	Screw 3.18 x 7	1	009660-7-12		L-59	Knife Rock Lever, Left	1	148577-0-01	
L-29	Screw 4.76	2	105173-0-04		L-60	Screw 4.76 x 14	1	009711-4-12	
L-30	Air Tube Assembly	1	149284-0-01		L-61	Knife Rock Arm	2	148572-0-01	
L-31	Air Tube	1	149283-0-00		L-62	Screw 6.35	2	014770-6-22	
L-32	Tube Holder	1	149286-0-01		L-63	Screw 6.35	2	148574-0-01	
L-33	Screw 3.57 x 8	2	009670-8-12		L-64	Spring	1	148571-0-01	
L-34	Nylon Clamp	1	149287-0-00		L-65	Spring Hook, Left	1	148580-0-01	
L-35	Washer	1	105161-0-02		L-66	Screw 4.76 x 10	2	009711-0-12	
L-36	Screw 3.57 x 8	1	009670-8-12						

# M. Synchronizer Mechanism

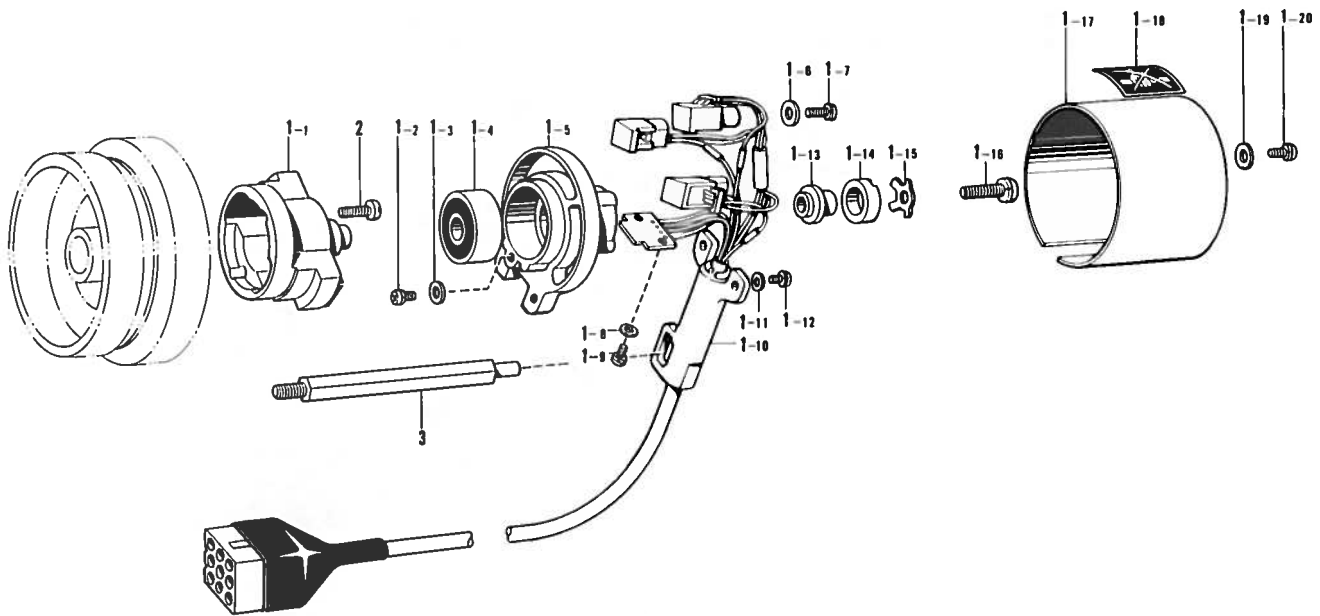

Ref. No.	Name of Parts	Q'ty	Parts No.	Assembly No.	Ref. No.	Name of Parts	Q'ty	Parts No.	Assembly No.
M-1- 1	Magnet Stud	1		M-1 Synchronizer Assembly #7 222370-0-01	M-1-12	Screw 4 x 10D	2	215080-0-01	M-1 Synchronizer Assembly #7 222370-0-01
M-1- 2	Screw 3 x 6D	1	215083-0-01		M-1-13	Magnet Support	1	219557-0-00	
M-1- 3	Washer	1	025030-3-35		M-1-14	Magnet	1	219558-0-00	
M-1- 4	Bearing 6201VV	1			M-1-15	Magnet Presser Plate	1	219559-0-00	
M-1- 5	Synchronizer Holder	1			M-1-16	Screw 6 x 25D	1	221421-0-01	
M-1- 6	Washer	3	025040-3-35		M-1-17	Synchronizer Cover	1		
M-1- 7	Screw 4 x 12D	3	217093-0-01		M-1-18	Label	1		
M-1- 8	Washer	2	025030-1-35		M-1-19	Washer	2	025040-3-35	
M-1- 9	Screw 3 x 6 D	2	215083-0-01		M-1-20	Screw 4 x 10D	2	215080-0-01	
M-1-10	Hole I.C With Cord	1			M-2	Screw 4.76 x 14	2	009711-4-12	
M-1-11	Washer	2	025040-1-35		M-3	Synchronizer Holder Stud	1	148615-0-01	



# N. Control Box Mechanism

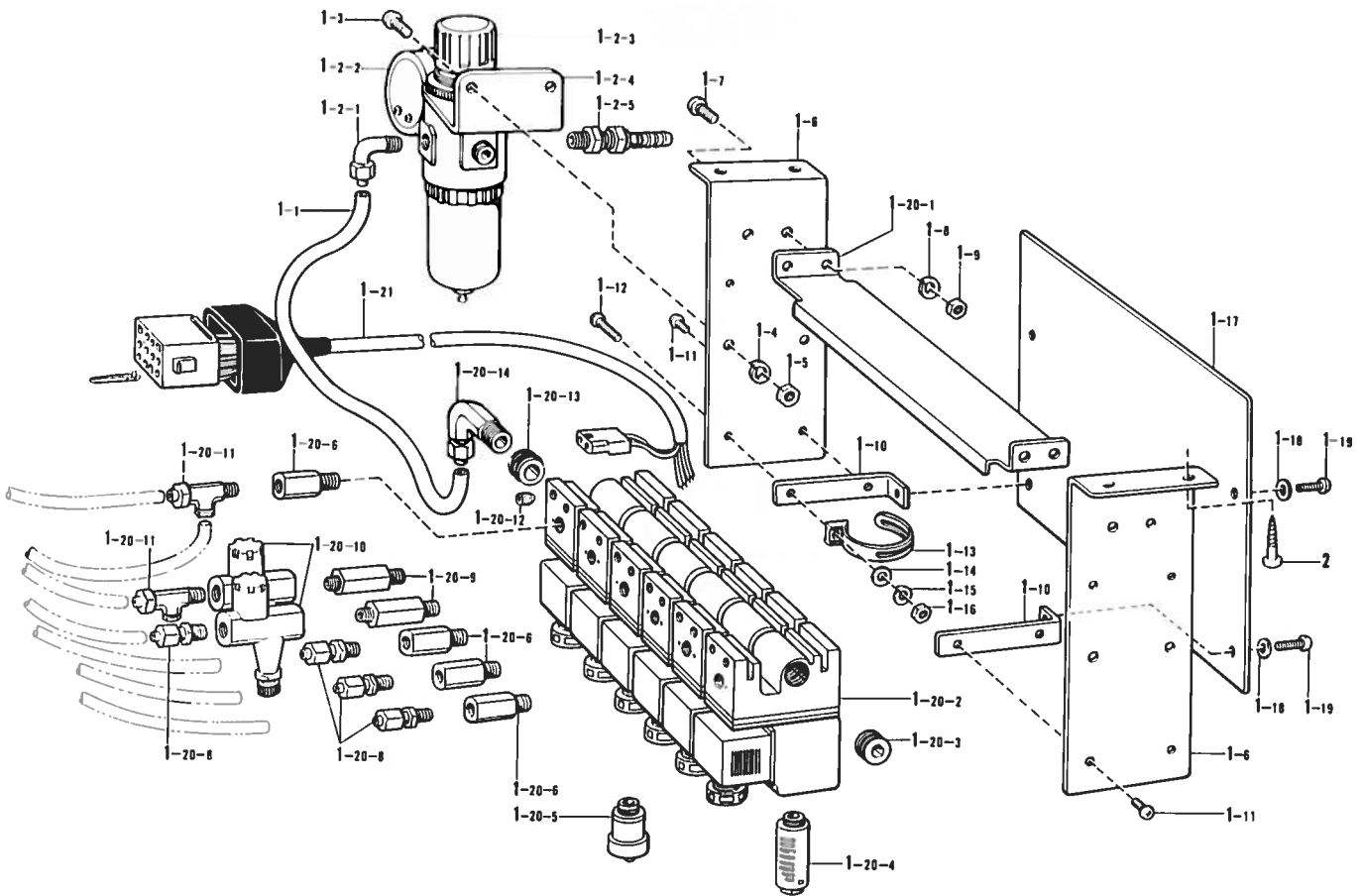

Ref. No.	Name of Parts	Q'ty	Parts No.	Assembly No.	Ref. No.	Name of Parts	Q'ty	Parts No.	Assembly No.
N-1- 1	Air Tube	1	140540-0-00	N-1-2 Air Unit Assembly 154765-0-01	N-1-17	Rear Plate	1		N-1 Valve Box Assembly 154492-0-01
N-1- 2-1	1/4" Elbow	1	140538-0-00		N-1-18	Washer	4	025030-2-33	
N-1- 2-2	Presser Gauge	1			N-1-19	Screw 3 x 6	4	002300-6-13	
N-1- 2-3	Air Unit	1	143960-1-01		N-1-20- 1	Solenoid Valve Base	1	153077-0-01	
N-1- 2-4	Air Unit Holder Plate	1			N-1-20- 2	Solenoid Valve	5	145827-0-01	
N-1- 2-5	Air Tube Connector	1	140678-0-00		N-1-20- 3	1/4" Cap	1	140542-0-01	
N-1- 3	Screw 5 x 10	2	002501-0-64		N-1-20- 4	Silencer	5	140682-0-01	
N-1- 4	Washer	2	028050-2-43		N-1-20- 5	Solenoid Valve (O)	1	149156-0-01	
K-1- 5	Nut	2	021500-1-63		N-1-20- 6	Valve Connector	4	140539-0-00	
N-1- 6	Side Plate	2			N-1-20- 8	1/8" Connector	4	140543-0-00	
N-1- 7	Screw 5 x 10	4	002501-0-64	N-1-20- 9	Speed Control Connector	2	142037-0-00		
N-1- 8	Washer	4	028050-2-43	N-1-20-10	Speed Controller	2	142038-0-01		
N-1- 9	Nut	4	021500-1-63	N-1-20-11	Air Tube Connector	2	140544-0-00		
N-1-10	Plate Supporter	4		N-1-20-12	Screw	24	016500-8-22		
N-1-11	Screw 3 x 6	7	002300-6-13	N-1-20-13	Bushing With "O" Ring	5	140680-0-00		
N-1-12	Screw 3 x 16	1	002301-6-03	N-1-20-14	1/4" Elbow	1	140538-0-00		
N-1-13	Cord Holder	1	144910-0-01	N-1-21	Valve Cord Assembly	1	154494-0-01		
N-1-14	Washer	1	025030-1-33	N-2	Screw 5.5 x 20	4	100666-0-02		
N-1-15	Washer	1	028030-2-43						
N-1-16	Nut	1	021300-1-03						

# P. Presser Foot Lifter Cord Mechanism

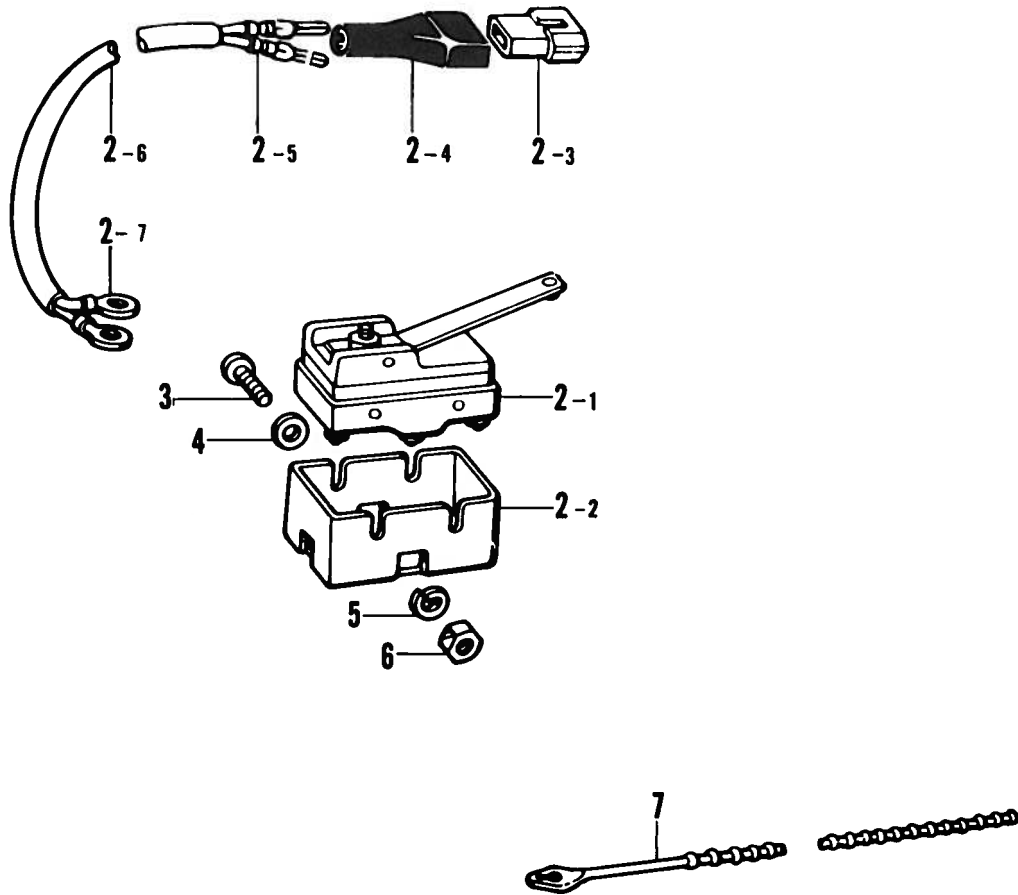

Ref. No.	Name of Parts	Q'ty	Parts No.	Assembly No.	Ref. No.	Name of Parts	Q'ty	Parts No.	Assembly No.
P-2-1	Micro Switch	1	140948-0-01	P-2 Presser Foot Lifter Cord Assembly 154496-0-01	P-3	Screw 3 x 30	2	002303-0-06	
P-2-2	Cover	1	140950-0-00		P-4	Washer	2	025030-2-33	
P-2-3	Nylon Connector	1	143488-0-01		P-5	Washer	2	028030-2-43	
P-2-4	Connector Cap	1	143489-0-01		P-6	Nut	2	021300-1-03	
P-2-5	Terminal Pin	2	143549-0-00		P-7	Bead Band	1	144189-0-01	
P-2-6	Presser Foot Lifter Cord	1							
P-2-7	Terminal	2	140693-0-00						

# Z. Accessories

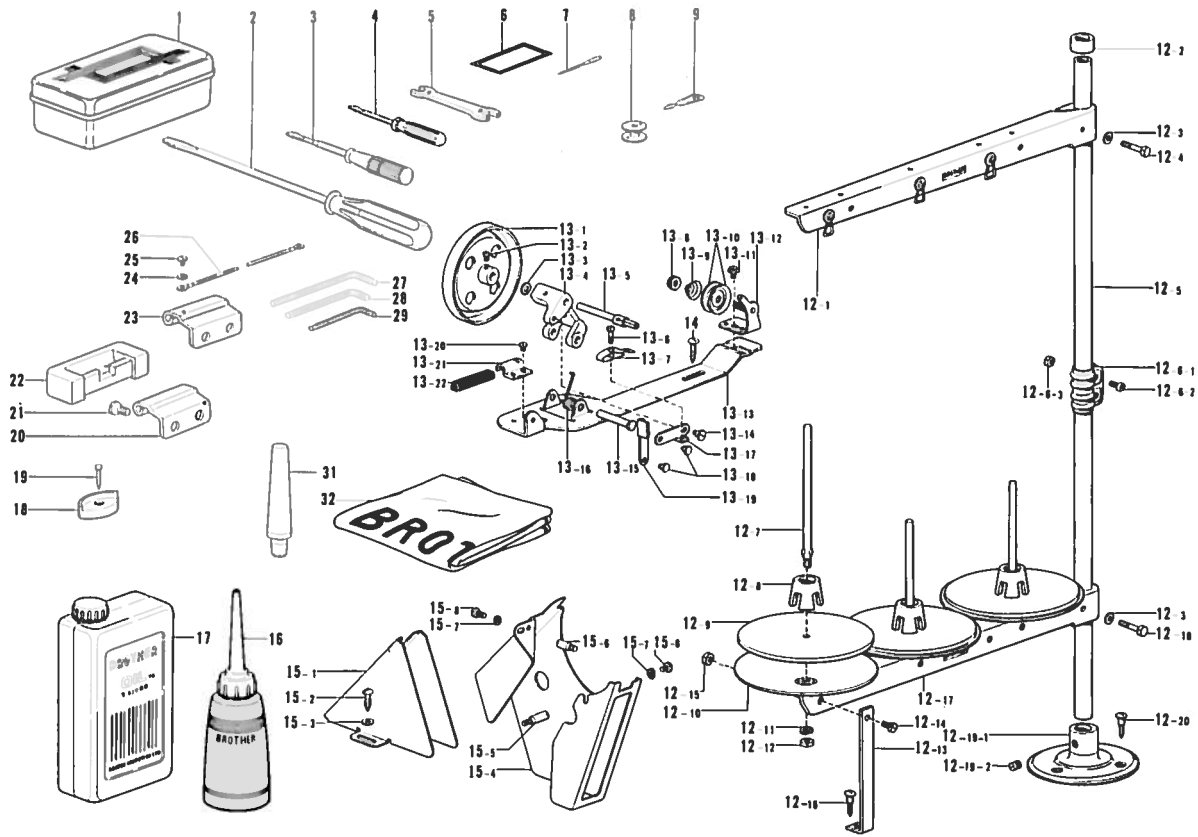

Ref. No.	Name of Parts	Q'ty	Parts No.	Assembly No.	Ref. No.	Name of Parts	Q'ty	Parts No.	Assembly No.
Z- 1	Accessory Box		110436-0-01		Z-13- 9	Tension Spring		100401-0-01	Z-13 Bobbin Winder Assembly 117963-0-01
Z- 2	Screw Driver 5.5 x 190		101572-1-01		Z-13-10	Tension Disc		145446-0-01	
Z- 3	Screw Driver 3.4 x 70		118837-0-01		Z-13-11	Screw 4.37			
Z- 4	Screw Driver 1.9 x 52		142443-0-01		Z-13-12	Bobbin Winder Guide Assembly			
Z- 5	Wrench 8 x 9		100887-0-01		Z-13-13	Bobbin Winder Wheel Bracket			
Z- 6	Needle Bag				Z-13-14	Screw 3.18		100659-0-01	
Z- 7	Needle DP x 5				Z-13-15	Pin			
Z- 8	Bobbin		148603-0-01		Z-13-16	Spring		117969-0-01	
Z- 9	Threader		103896-0-02		Z-13-17	Bobbin Presser Arm			
Z-12- 1	Thread Hanger Assembly		150193-0-01		Z-13-18	Pin		100661-0-01	
Z-12- 2	Column Cap			Z-12 Cotton Stand Assembly 150151-0-01	Z-13-19	Bobbin Presser Bracket			
Z-12- 3	Washer		025050-2-33		Z-13-20	Screw 3.57 x 3.5		009679-3-12	
Z-12- 4	Bolt 5 x 28		017502-8-03		Z-13-21	Bobbin Winder Wheel Stopper Holder			
Z-12- 5	Column Pipe		150172-0-01		Z-13-22	Bobbin Winder Wheel Stopper		100662-0-01	
Z-12- 6-1	Joint			Z-12-6 Joint for Cotton Stand 150106-0-01	Z-14	Screw 5.5 x 20		100666-0-02	
Z-12- 6-2	Screw 5 x 14		150202-0-01		Z-15-1	Belt Cover (D)			
Z-12- 6-3	Nut		021500-1-03		Z-15-2	Screw 5.5 x 20		100666-0-02	
Z-12- 7	Spool Shaft (B)		150179-0-01		Z-15-3	Washer		025750-1-32	
Z-12- 8	Spool Cushion		147060-0-01		Z-15-4	Belt Cover (UP)			
Z-12- 9	Spool Mat		150182-0-00		Z-15-5	Belt Cover Stud (B)		147856-0-02	
Z-12-10	Spool Disc		150180-0-00		Z-15-6	Stud		147858-0-01	
Z-12-11	Washer		028050-2-43		Z-15-7	Spring Washer		028680-2-42	
Z-12-12	Nut		021500-1-03	Z-12 Cotton Stand Assembly 150151-0-01	Z-15-8	Screw 4.37 x 8		009680-8-12	
Z-12-13	Spool Holder Supporter		150188-0-01		Z-16	Oiler		114483-0-01	
Z-12-14	Screw 5 x 10		007501-0-03		Z-17	Oil Tank		145277-1-03	
Z-12-15	Nut		021500-1-03		Z-18	Head Cushion		148890-1-01	
Z-12-16	Screw 4.5 x 22		031452-2-03		Z-19	Nail		109714-0-00	
Z-12-17	Spool Holder Assembly		150175-0-01		Z-20	Head Hinge		148882-0-01	
Z-12-18	Bolt 5 x 28		017502-8-03		Z-21	Screw 6.35		112569-0-01	
Z-12-19-1	Cotton Stand Base		150189-0-01	Z-12-19 Bracket Assembly 150139-0-01	Z-22	Rubber Hinge		143910-0-01	
Z-12-19-2	Screw 6 x 10		150181-0-01		Z-23	Hinge		150557-0-01	
Z-12-20	Screw 4.5 x 22		031452-2-03		Z-24	Washer		025680-2-34	
Z-13- 1	Bobbin Winder Wheel Assembly			Z-13 Bobbin Winder Assembly 117963-0-01	Z-25	Screw 4.37 x 6		009680-6-13	
Z-13- 2	Screw 4.37 x 5		100366-0-02		Z-26	Earth Wire		145946-0-01	
Z-13- 3	Washer				Z-27	Spanner		149570-0-01	
Z-13- 4	Bobbin Winder Wheel Shaft Supporter				Z-28	Spanner 3		142721-0-01	
Z-13- 5	Bobbin Winder Shaft		117970-0-01		Z-29	Spanner		142002-0-01	
Z-13- 6	Screw 3.18		100657-0-01		Z-31	Feet Rest		149010-0-00	
Z-13- 7	Bobbin Presser				Z-32	Head Cover		144222-0-01	
Z-13- 8	Tension Control Nut								

\*The details of included accessories are subject to change.

\*Les détails des accessoires inclus sont sujets à des changements.

\*Änderungen in der Aufstellung der mitgelieferten Zubehöre sind vorbehalten.

\*Los detalles de los accesorios incluidos pueden variar.

## DIFFERENT PARTS LIST

Ref. No.	Name of Parts	Sub-Class	-903	-905
		Gauge	1/4	1/4H
A-37	Tension Control Plate Assembly		181756-0-01	181755-0-01
A-37-13	Tension Spring		118317-0-01	148672-0-01
A-47	Arm Thread Guide, Center		112658-0-01	
A-48	Needle Thread Guide Assembly			148656-0-01
C- 8	Needle DP x 5		107415-0-14	107415-0-22
E-13	Presser Foot		148693-0-01	148695-0-01
F-62	Feed Dog		148704-0-01	148705-0-01
G- 6	Vertical Feed Eccentric Wheel Assembly		148804-0-01	181486-0-01
G-54	Bobbin Tension Spring		150823-0-01	148602-0-01
K- 9	Spring		148526-0-01	148527-0-01
Z- 7	Needle DP x 5		107415-0-14	107415-0-22

## GAUGE PARTS LIST

### For Thread Trimmer

Needle Gauge	Sub Class	Needle Plate Assembly	Feed Dog	Presser Foot Assembly	Needle Clamp with Screw	Connecting Rod Assembly
1/4 inch (6.4 mm)	-3	154507-0-01	148704-0-01	148693-0-01	150830-0-01	148585-0-01
	-5		148705-0-01	148695-0-01		
3/16 inch (4.8 mm)	-3	154714-0-01	148702-0-01	148687-0-01	150844-0-01	
	-5		148703-0-01	148691-0-01		
5/32 inch (4.0 mm)	-3	154716-0-01	148700-0-01	148689-0-01	150843-0-01	148581-0-01
	-5		148701-0-01	148683-0-01		
5/16 inch (7.9 mm)	-3	154718-0-01	149692-0-01	149689-0-01	150845-0-01	149697-0-01
	-5		149691-0-01	149687-0-01		
3/8 inch (9.5 mm)	-3	154720-0-01	149939-0-01	149942-0-01	150846-0-01	
	-5		149938-0-01	149940-0-01		
1/8 inch (3.2 mm)	-3	154722-0-01	148698-0-01	148685-0-01	150885-0-01	
	-5		148699-0-01	148681-0-01		

# I N D E X

Parts No.	Ref. No.	Remark	Parts No.	Ref. No.	Remark	Parts No.	Ref. No.	Remark	Parts No.	Ref. No.	Remark
001630-4-12	L- 8		013761-4-10	B-22		100242-0-03	F-61		112072-0-01	F- 7	
001639-3-12	C- 2-19- 2			B-28		100248-0-01	B-23		112560-0-03	A- 6	
001660-5-12	C- 2-18			F-41		100250-0-01	B- 6		112561-0-02	A- 4	
	C-13			F-49		100251-0-01	B-10		112566-0-03	A- 9	
001670-6-12	H-15		013771-2-12	B-27			G-17		112569-0-01	Z-21	
002300-6-13	N- 1-11			G-14		100260-0-01	E- 3		112572-0-01	B-20	
	N- 1-19		013780-7-10	G- 9		100320-0-02	G-44		112573-0-01	B-14	
002301-6-03	N- 1-12		014760-6-22	J- 57			G-53		112576-0-01	B-13	
002303-0-06	P- 3		014770-6-22	L-16		100328-0-01	F-16		112586-0-01	B-24	
002501-0-64	N- 1- 3			L-18		100366-0-02	Z-13- 2		112594-0-01	B-43	
	N- 1- 7			L-62		100401-0-01	Z-13- 9		112595-0-00	B-33	
005671-2-12	G-11		015771-0-12	J- 50		100645-0-03	G-49		112596-0-01	B-41	
007401-0-13	K- 2		015771-2-12	B-26			J- 60		112597-0-01	B-42	
007501-0-03	Z-12-14		016500-8-22	N- 1-20-12		100657-0-01	Z-13- 6		112598-0-01	B-38	
009660-4-12	H-41		017502-8-03	Z-12- 4		100659-0-01	Z-13-14		112606-0-01	A-31	
009660-7-12	L-28			Z-12-18		100661-0-01	Z-13-18		112607-0-01	A-34	
008670-5-12	B-36		018061-6-22	L-13		100662-0-01	Z-13-22		112609-0-01	C- 2-19-15	
	C-11		021300-1-03	N- 1-16		100666-0-02	N- 2		112614-0-01	E- 1	
	H-36			P- 6			Z-14		112615-0-01	E- 2	
	H-43		021500-1-03	Z-12- 6- 3			Z-15- 2		112616-0-01	E- 9	
	H-45			Z-12-12		100887-0-01	Z- 5		112618-0-01	E- 7	
	H-52			Z-12-15		101268-0-03	B-37		112619-0-01	E- 8	
009670-6-12	A-10		021500-1-63	N- 1- 5		101572-1-01	Z- 2		112623-0-01	E-21	
	A-40			N- 1- 9		101706-0-01	B- 9		112624-0-01	E-19	
	A-51		021660-1-03	F-55			F-34- 2		112626-0-01	E-17	
	A-53		021670-1-02	A-37-25			F-47		112630-0-01	E-16	
	H- 9			J- 3			G-18		112631-0-01	E- 6	
009670-8-12	A- 2			L-46		102731-0-04	C- 2-23		112656-0-01	F-59	
	E-10			D-35		102843-0-01	C- 2- 5		112658-0-01	A-23	
	G-21		025030-1-33	N- 1-14		103896-0-02	Z- 9			A-48	
	L-33		025030-1-35	M- 1- 8		104908-0-04	F-51		112666-0-00	G- 8- 1	
	L-36		025030-2-33	N- 1-18		105161-0-02	G-20		112667-0-01	G- 8- 2	
009671-0-12	D-19			P- 4			L-35		112668-0-01	G-10	
009679-3-12	H- 4		025030-3-35	M- 1- 3		105173-0-04	L-29		112684-0-01	G- 6	
	K-22		025040-1-35	M- 1-11		105234-0-01	G-47			G-16	
	Z-13-20		025040-2-33	K- 3		105248-0-03	D-33		112686-0-01	G-41	
009680-6-13	Z-25		025040-3-35	M- 1- 6		105351-0-02	B-34		112687-0-01	G-31	
009680-7-12	D- 2			M- 1-19		106640-0-01	H-12		112690-0-01	G-33	
	E- 4- 2		025050-2-33	Z-12- 3		107030-0-01	C- 2-12		112692-0-01	G-23	
009680-8-12	Z-15- 8		025060-1-32	F-58		107155-0-01	G-28		112694-0-01	G-22	
009681-0-12	F-35- 3		025630-1-32	L- 7		107231-0-02	A- 5		112695-0-01	G-27	
	J- 61		025680-2-34	Z-24		107272-0-02	D- 4		112696-0-00	A-13	
009681-0-13	A- 8		025710-2-32	G-25			D-16			G-29	
009681-2-14	D-29			J- 32		107278-0-02	F-56		112697-0-01	G-19	
009681-4-14	K-28		025750-1-32	Z-15- 3		107404-0-00	C- 7		112698-0-01	G- 8	
009681-6-13	A- 7		025770-2-32	G-42		107407-0-03	K- 4		112699-0-01	G-35	
009710-8-12	F-27		028030-2-43	N- 1-15			K- 7		112700-0-01	G-36	
	H-18			P- 5		107415-0-14	C- 8		112702-0-01	G-52	
	L- 5		028050-2-43	N- 1- 4			Z- 7		112709-0-01	A-39	
009710-8-13	D-27			N- 1- 8		107415-0-22	C- 8		112712-0-01	A-37-12	
009711-0-12	H-39			Z-12-11			Z- 7		112716-0-01	H-16	
	L-20		028350-2-42	D-34		107794-0-01	G-32		112717-0-01	H-17	
	L-66		028680-2-42	Z-15- 7			G-34		112723-0-01	H-10	
009711-2-12	J- 20		028680-2-43	G-48		108254-0-01	A-37- 5		112724-0-01	H- 6	
009711-4-12	J- 58		031452-2-03	Z-12-16		108263-0-01	A-37-15		112725-0-01	H- 5	
	L-55			Z-12-20		108265-0-01	A-37- 7		112730-0-01	H- 3	
	L-60		048030-3-42	L-25		108266-0-01	A-18		112734-0-01	B-16	
	M- 2			L-47- 2		108549-0-01	F-10		112735-0-00	B-12	
	M- 5		048040-3-42	J- 29		108960-0-04	A-17		112735-0-01	B- 4	
009711-4-13	K-14			J- 43			A-19		112736-0-00	H-22	
009711-6-12	J- 33			L-49			A-24		112739-0-01	B-35	
	L-53		048060-3-42	F-43			A-49			C-10	
009761-4-12	F-57		048070-3-42	F- 3		108962-0-01	Z- 6		112743-0-01	H-42	
009781-8-12	B-39		048080-3-42	K-30		109714-0-00	H-49		112744-0-01	H-44	
	F-45		072620-4-60	B-30			Z-19		112745-0-01	H-51	
009782-5-12	J- 38		081016-0-70	H-47		110161-0-06	G-26		112751-0-02	A-29	
011679-3-12	D- 9		100032-0-03	A-33		110171-0-01	J- 18		112753-0-01	H-20	
013660-4-13	C- 3- 2		100043-0-03	D-14			J- 47		112754-0-01	H-19	
013710-7-12	J- 37		100064-0-02	A-38		110436-0-01	Z- 1		112755-0-01	G-40	
013761-4-10	B-15		100105-0-02	C- 2-19- 9		110735-0-01	D-30		112756-0-01	G-50	

Parts No.	Ref. No.	Remark	Parts No.	Ref. No.	Remark	Parts No.	Ref. No.	Remark	Parts No.	Ref. No.	Remark
112758-0-01	H-21		142721-0-01	Z-28		148503-0-00	G-2		148666-0-01	A-37-24	
112759-0-01	F-60		142746-0-02	F-14		148505-0-01	G-1		148667-0-01	A-37-23	
112760-0-01	B-29		142747-0-02	F-15		148508-0-01	K-15		148668-0-01	A-37-22	
112762-0-01	H-1		143488-0-01	P-2-3		148509-0-01	K-18		148669-0-01	A-37-14	
112764-0-01	B-40		143489-0-01	P-2-4		148511-0-01	K-18-2		148670-0-01	A-37-17	
113024-0-00	B-19		143549-0-00	K-18-3		148513-0-01	K-1		148671-0-01	A-37-16	
113050-0-01	E-14			K-27-3		148514-0-01	K-21		148672-0-01	A-37-13	
113074-0-01	F-46			P-2-5		148515-0-01	K-16		148681-0-01	E-13	
113362-0-01	G-4		143591-0-01	F-53		148516-0-01	K-6		148683-0-01	E-13	
113386-0-00	A-30		143594-0-01	F-35-2		148517-0-00	K-8		148685-0-01	E-13	
113524-0-01	H-13		143597-0-01	F-37		148518-0-00	K-5		148687-0-01	E-13	
113526-0-01	H-8		143598-0-01	F-11		148521-0-01	K-17		148689-0-01	E-13	
114297-0-01	H-7		143609-0-01	F-25		148526-0-01	K-9		148691-0-01	E-13	
	H-35		143610-0-01	F-26		148527-0-01	K-9		148693-0-01	E-13	
114483-0-01	Z-16		143613-0-01	F-38-3		148529-0-01	K-13		148695-0-01	E-13	
114486-0-01	H-50		143616-0-01	F-42		148530-0-01	K-12		148698-0-01	F-62	
114680-0-01	B-21		143657-0-01	H-11		148531-0-01	L-4		148699-0-01	F-62	
114693-0-01	B-18		143673-0-01	H-40		148535-0-01	L-9		148700-0-01	F-62	
115177-0-01	J-12		143766-0-01	F-1		148536-0-01	L-10		148701-0-01	F-62	
115249-0-01	G-3		143910-0-01	Z-22		148537-0-01	L-11		148702-0-01	F-62	
115638-0-04	D-17					148538-0-01	L-1		148703-0-01	F-62	
116010-0-01	A-36		148530-0-01	N-1-2-3		148539-0-01	L-3		148704-0-01	F-62	
116283-0-01	F-63		144189-0-01	P-7		148546-0-01	K-19		148705-0-01	F-62	
116558-0-01	H-46		144222-0-01	Z-32			L-22		148708-0-01	A-32-2	
117160-0-01	J-8		144680-0-01	A-37-9		148547-0-01	L-37		148709-0-01	A-32-3	
117666-0-01	L-45		144681-0-01	A-37-8		148555-0-01	L-38		148728-0-01	G-45	
117963-0-01	Z-13		144682-0-01	A-37-6		148557-0-01	L-41		148729-0-01	H-37	
117969-0-01	Z-13-16		144683-0-01	A-37-10		148559-0-00	L-39		148730-0-01	H-23	
117970-0-01	Z-13-5		144910-0-01	N-1-13		148571-0-01	L-64		148731-0-00	H-24	
118170-0-01	E-20		145227-1-13	Z-17		148572-0-01	L-61		148732-0-01	H-38	
118317-0-01	A-37-13		145328-0-01	F-35-4		148573-0-01	L-56		148733-0-01	H-27	
118320-0-01	A-37-11		145446-0-01	Z-13-10		148574-0-01	L-15			H-33	
118713-0-01	F-29		145502-0-01	F-17			L-63		148734-0-00	H-34	
	J-27					148577-0-01	L-59		148735-0-01	H-29	
118735-0-01	D-5		145827-0-01	N-1-20-2		148580-0-01	L-65		148736-0-00	H-30	
118746-0-01	F-6		145946-0-01	Z-26		148584-0-01	L-57-2		148737-0-01	H-31	
118747-0-01	F-8		146080-0-00	K-20		148585-0-01	L-57		148738-0-00	H-32	
118837-0-01	Z-3			K-26		148599-0-01	A-35		148740-0-00	H-28	
118853-0-01	F-9					148602-0-01	G-54		148741-0-01	H-25	
	F-33		146124-0-01	K-31		148603-0-01	G-38		148742-0-00	H-26	
118954-0-00	F-38-2		146125-0-01	K-29			Z-8		148743-0-01	F-36	
120264-0-01	C-2-7		146128-0-00	K-32-2		148604-0-00	A-20		148762-0-01	H-14	
123882-0-01	J-10		146141-0-01	B-7		148605-0-01	E-11		148764-0-01	J-45	
140527-0-01	A-11		146153-0-01	J-26		148606-0-02	J-52		148768-0-01	J-4	
140538-0-00	N-1-20-14			J-42		148607-0-01	J-49		148770-0-01	K-10	
	N-1-2-1			L-48		148608-0-01	J-53		148771-0-01	F-35	
140539-0-00	N-1-20-6		146699-0-00	L-23		148609-0-01	J-56		148801-0-01	F-38	
140540-0-00	N-1-1		147060-0-01	Z-12-8		148610-0-01	A-21		148802-0-01	F-39	
140542-0-01	N-1-20-3		147856-0-02	Z-15-5		148611-0-01	A-54		148804-0-01	G-6	
140543-0-00	N-1-20-8		147858-0-01	Z-15-6		148614-0-01	A-45		148818-0-01	A-50	
140544-0-00	N-1-20-11		147908-0-01	Z-15		148615-0-01	M-3		148821-0-01	G-13	
140620-0-01	J-34		148005-0-01	G-24		148623-0-01	J-9		148825-0-01	M-4	
	J-36		148480-0-01	G-51		148625-0-01	J-13		148835-0-01	E-4	
	L-52		148481-0-01	G-39		148628-0-01	J-14		148882-0-01	Z-20	
140678-0-00	N-1-2-5		148483-0-01	E-5			J-17		148890-1-01	Z-18	
140680-0-00	N-1-20-13		148486-0-01	E-15		148629-0-01	J-16		149010-0-00	Z-31	
140682-0-01	N-1-20-4		148487-0-01	F-28		148630-0-01	J-15		149019-0-01	J-30	
140693-0-00	P-2-7		148488-0-01	F-2		148631-0-01	J-1		149023-0-01	J-31	
140948-0-01	P-2-1		148489-0-01	F-5		148632-0-01	J-2		149024-0-01	J-25	
140950-0-00	P-2-2		148490-0-01	F-52		148633-0-01	J-7		149025-0-01	J-24	
141439-0-01	J-28		148491-0-01	F-54		148634-0-01	J-5		149027-0-01	J-21	
141494-0-01	J-23		148492-0-01	F-50		148635-0-01	J-6		149030-0-01	J-35	
	L-58		148493-0-01	F-40		148638-0-01	J-55		149031-0-01	J-41	
141748-0-01	J-48		148494-0-01	F-48		148640-0-01	J-54		149033-0-01	J-44	
142002-0-01	Z-29		148495-0-01	F-44		148654-0-01	J-11		149034-0-01	J-39	
142037-0-00	N-1-20-9		148496-0-00	F-38-1		148656-0-01	A-47		149035-0-01	J-19	
142038-0-01	N-1-20-10		148498-0-00	F-35-1		148662-0-01	A-37-21		149036-0-01	L-12	
142268-0-01	A-52		148500-0-01	F-32		148663-0-01	A-37-19		149037-0-01	L-50	
			148501-0-01	F-30		148664-0-01	A-37-20		149040-0-01	L-51	
142443-0-01	Z-4		148502-0-00	G-7		148665-0-01	A-37-18		149042-0-01	L-54	

Parts No.	Ref. No.	Remark	Parts No.	Ref. No.	Remark	Parts No.	Ref. No.	Remark	Parts No.	Ref. No.	Remark
149043-0-01	L-21		149868-0-01	D-13		153606-0-01	C- 2- 2				
149049-0-01	L-19		149870-0-01	K-23		154491-0-01	D-22				
149050-0-01	L-17		149873-0-01	K-24		154492-0-01	N- 1				
149052-0-01	L-43		149938-0-01	F-62		154493-0-01	N- 1-20				
149055-0-01	L-27		149939-0-01	F-62		154494-0-01	N- 1-21				
149056-0-01	L-26		149940-0-01	E-13		154496-0-01	P- 2				
	L-47- 5		149942-0-01	E-13		154498-0-01	D-26				
149058-0-01	L-47		149991-0-01	J- 22		154506-0-01	B-31				
149061-0-01	L-14		150106-0-01	Z-12- 6		154507-0-01	A-32				
149063-0-01	J- 46		150139-0-01	Z-12-19		154509-0-01	K-32				
149156-0-01	N- 1-20- 5		150151-0-01	Z-12		154514-0-01	D-32				
149169-0-01	L- 2		150172-0-01	Z-12- 5		180157-0-01	B-25				
149177-0-01	K-11		150175-0-01	Z-12-17		180164-0-01	G-12				
149179-0-01	A-55		150179-0-01	Z-12- 7		180321-0-01	F-34				
149241-0-01	L-24		150180-0-00	Z-12-10		180949-0-01	G-15				
149281-0-01	L-44		150181-0-01	Z-12-19- 2		181486-0-01	G- 6				
149282-0-01	J- 59		150182-0-00	Z-12- 9		181712-0-01	L-42				
149283-0-00	L-31		150188-0-01	Z-12-13		181713-0-01	L-40				
149284-0-01	L-30			Z-12-19- 1		181755-0-01	A-37				
149285-0-01	J- 40		150193-0-01	Z-12- 1		181756-0-01	A-37				
149286-0-01	L-32		150202-0-01	Z-12- 6- 2		215080-0-01	M- 1-12				
149287-0-01	L-34		150369-0-01	C- 2			M- 1-20				
149288-0-01	A-46		150372-0-01	G-37		215083-0-01	M- 1- 2				
149554-0-01	J- 51		150374-0-00	C- 9			M- 1- 9				
149569-0-01	G-43		150553-0-03	A-12		217093-0-01	M- 1- 7				
149570-0-01	Z-27		150557-0-01	Z-23		219557-0-00	M- 1-13				
149604-0-01	C- 2-19-11		150815-0-01	A- 3		219558-0-00	M- 1-14				
149605-0-01	C- 2-19-13		150816-0-01	C- 2-21		219559-0-00	M- 1-15				
149606-0-01	C- 2-19-14		150817-1-01	C- 1		221421-0-01	M- 1-16				
149607-0-01	C- 2-19-16		150821-0-00	L- 6		222370-0-01	M- 1				
149608-0-01	C- 2-19- 7		150823-0-01	G-54		222773-0-01	D-25				
149609-0-01	C- 2-19- 8		150824-0-01	K-25		503093-0-01	H- 2				
149610-0-01	C- 2-19- 3		150825-0-01	C-15							
149611-0-01	C- 2-19- 4		150830-0-01	C- 3		153969-0-00	D-23				
149612-0-01	C- 2-19- 1		150843-0-01	C- 3		154765-0-01	N- 1- 2				
149613-0-01	C- 2-20		150844-0-01	C- 3							
149614-0-01	C- 2- 8		150845-0-01	C- 3							
149615-0-01	C- 2- 9		150846-0-01	C- 3							
149616-0-01	C- 2- 6		150885-0-01	C- 3							
149617-0-01	C- 2- 4		151007-1-01	H-48							
149618-0-01	C- 2- 3		151029-0-01	G-37- 2- 5							
149621-0-01	C- 2-15		151030-0-01	G-37- 2- 6							
149622-0-01	C- 2-16		151034-0-01	G-37- 2- 2							
149623-0-01	C- 2-17		151035-0-01	G-37- 2- 3							
149624-0-01	C- 2-13		151043-0-01	G-37- 2- 4							
149625-0-01	C- 2-14		151044-0-01	G-37- 2							
149626-0-01	C-12		151507-0-01	F-13							
149687-0-01	E-13		151602-0-01	F-31							
149689-0-01	E-13		151602-0-02	A-25							
149691-0-01	F-62		151604-0-01	E-12							
149692-0-01	F-62			G- 5							
149768-0-01	E-18		151605-0-01	B- 2							
149819-0-03	A- 1			F- 4							
149820-0-00	B- 5			F-39- 2							
149821-0-01	B- 8		151626-0-01	D-31							
149823-0-01	B- 3		151884-0-00	K-27							
149824-0-01	B- 1		153063-0-00	A-44							
149825-0-01	B-17		153064-0-01	D- 3							
149826-0-01	A-16		153065-0-01	D- 7							
149827-0-01	C- 2-19- 6		153066-0-01	D- 6							
149831-0-01	C- 4		153067-0-01	D-18							
149832-0-01	C- 6		153068-0-01	D-20							
149833-0-01	C- 5		153069-0-01	D-21							
149834-0-00	C-14		153073-0-01	D- 1							
149853-0-01	D-28		153074-0-01	K-32- 1							
149860-0-01	D-10		153077-0-01	N- 1-20- 1							
149863-0-01	D-12		153168-0-01	F-12							
149864-0-01	D- 8		153243-0-01	G-55							
149865-0-01	D-11		153483-0-01	G-30							
149867-0-01	D-15		153604-0-01	C- 2- 1							

