

# INSTRUCTION MANUAL

For

## BROTHER MA4-B972C

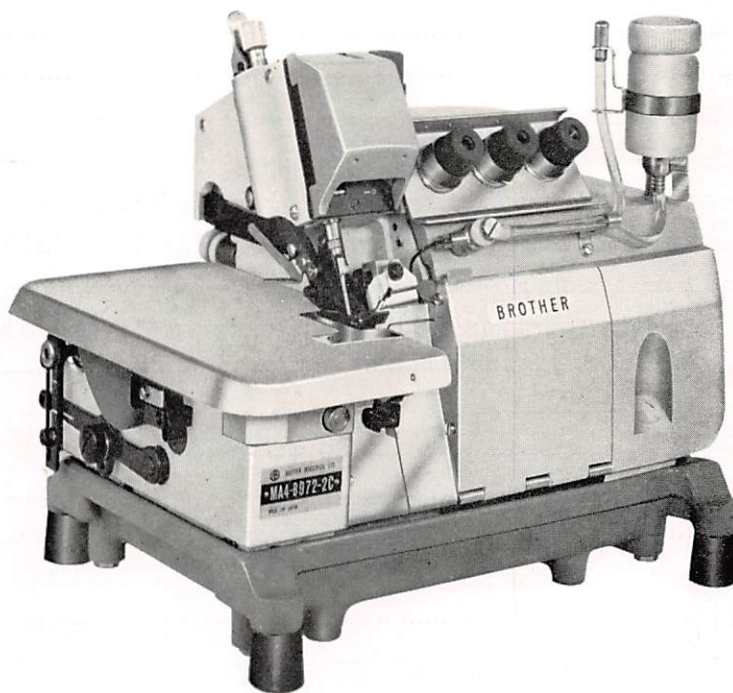

High Speed Safety Stitch Overlock Machine

**BROTHER INDUSTRIES, LTD.**

NAGOYA JAPAN

# CONTENTS

1. Specification .....	1
2. Features .....	2
3. Operation .....	3
A) Sewing Speed .....	3
B) Motor, motor pulley and belt .....	3
C) Setting up .....	3
D) Oiling, draining and maintenance .....	4
E) Needle cooler device .....	5
F) Machine operating direction .....	6
G) Installing needles .....	6
H) Threading .....	6
I) Stitches .....	7
J) Thread tension .....	7
1. Adjustment of thread take-up .....	7
2. Adjusting double chain stitch needle thread guide .....	7
3. Adjusting looper thread take-up and thread guide for overlock stitch .....	8
4. Adjusting looper thread take-up and thread guides for double chain stitch .....	8
5. Adjusting thread tension screws .....	8
K) Adjustment on pressure of presser foot: installing and removing feed dogs: and height of feed dogs .....	8
L) Adjusting stitch width .....	9
M) Adjusting stitch length .....	10
N) Adjusting differential feed .....	10
4. Adjustment .....	11
A) Height of needles .....	11
B) Relation between needle and under looper .....	11
C) Installing needle guard .....	11
D) Matching needle guard and needle .....	11
E) Relation of needle with under looper and over looper .....	12
F) Relation between needle and double chain stitch looper .....	12
G) Installing double chain stitch needle guard .....	13
H) Installing and maintenance of knives .....	13
5. Trouble shooting .....	14
A) Thread breaks .....	14
B) Skip stitching .....	14
C) Needle breaks .....	14
D) Imperfect chaining-off .....	15
E) Improper thread tension .....	15
F) Poor trimming performance .....	15
G) Irregular stitches .....	16
H) Excessive wrinkles along stitches .....	16
I) Needles produce too large holes .....	16

## 1. Specifications

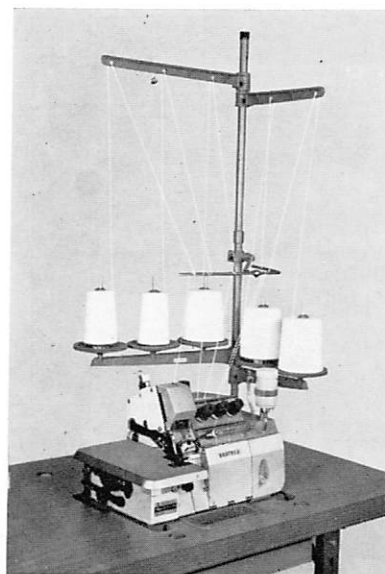
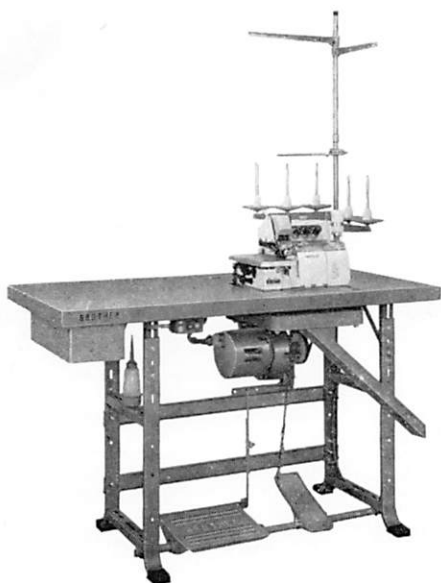

Name	High speed safety stitch overlock sewing machine
Dimensions	355mm × 240mm × 270mm
Type	Dust-proof, oil-proof, totally enclosed type
Stitch form	E13 & D12, E13A & D12, E12A & D12 simultaneous sewing
Use	Overedging and blind-hemming of garments, knitweares; Joint seaming on sleeves and other types of sewing in general
Sewing speed	6,000 stitches per minute
Stitch length	1.7mm-3.6mm (7-15 stitches per inch)
Stitch width	Needle gauge; 2, 3, 5mm Overedge; 3-5mm by changing the needle plate
Height of presser foot	5mm
Lubrication	Automatic lubrication by geared pump plus splash lubrication and lubrication by oil wick.
Main bearings and rods	All important parts are of phospher bronze alloy also oilless metal and ball bearings
Oil	Viscosity: CS 20.62 at 37.8°C Capacity: 800~1,000cc.
Needle bar stroke	24mm
Needle	DC×1 (≠11, ≠14, ≠16) for overlock stitch DM×13 (≠11, ≠14, ≠16) for double chain stitch
Feed regulator	Push-button type, scale on face plate represents stitch length
Differential feed regulator	By lever moving in vertical directions; gathering and stretching can be obtained even in sewing operation.
Knives	Upper knife; L-shaped carbide tipped Lower knife; flat shaped steel
Installation	Semi-submerged (Machine head is installed on the bottom board on which cushion can support machine head. Only oil reservoir is located below the table top.

Of this machine, there are the following sub-classes available.

## SUB-CLASS LIST AND EXPLANATION ON THE MEDALLION

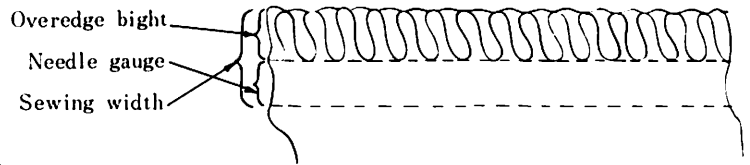
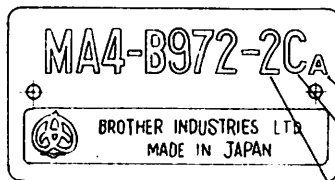

Sub-class	-2C	-3C	-5C
Needle gauge	2mm	3mm	5mm
Overedge bight	3mm	5mm	5mm
Sewing width	5mm	8mm	10mm
No. of needles	2	2	2
No. of threads	A.....5	5	5
	B.....4	4	4
Differential feed ratio	1.5-0.7	1.5-0.7	1.5-0.7
Needle cooler	Equipped	Equipped	Equipped
Use	For thin work	For medium work	For medium heavy work

## 2. Features

The extensive design of various components and lubrication system and also the addition of the needle cooler device on this model assure the normal operation of maximum high speed of 6,000 stitches per minute, without any troubles.

- A) Combined lubrication system of forced lubrication by geared pump, splash lubrication and oil wick lubrication.
  - B) Unique design of needle bar mechanism has lessened its weight as well as ensures forced lubrication to its every working part.
  - C) Exclusively designed over looper mechanism has made the use of light alloy possible and also ensures smooth lubrication to the end.
  - D) Holders are made of duralmin to decrease weight. Main rods and bushings are made of phospher bronze alloy.
  - E) Major moving parts are perfectly lubricated inside the totally enclosed main body, so they will never be exposed to outside dusts.
- \* The upper knife is L-shaped to make the threading and replacement of the needle easy. Besides the carbide tip promises long durability of the knife.
  - \* Stitch can be easily regulated by push-button, with the scale on the face plate, thus it is unnecessary to change the eccentrics when you would like to change the stitch length.
  - \* Differential feed can be easily adjusted by the lever for gathering or stretching without soiling your hands. This also applies for the instantaneous differential adjustment obtainable.
  - \* Durable chain stitch looper's movement in forward-backward direction can be adjusted to obtain the proper amount of clearance between the looper and needle according to the size of needle.
  - \* Thread tension of the double chain stitch looper can be easily adjusted without opening the cover.
  - \* Ample space on the cloth plate allows easy sewing operation and if you want, double chain stitch with edge cutting work can be obtained without using the overedging mechanism.
  - \* Oil level in the oil reservoir is shown on the special oil gauge on the front side of the machine.
  - \* Lubrication can be easily checked through the oil window in the top cover.
  - \* Needle cooler device ensures perfect sewing operation even with synthetic materials and threads at the high speed of 6,000 stitches per minute.
  - \* Colour combination of TAN-BEIGE is in well harmony with your modern factory, and operator's atigue can be lessened.
  - \* As differential ratio can be adjusted up to 2.5, this is suitable for sewing of cloth which is ease to spread such as knitted fabric.

### 3. Operation

#### A. Sewing speed

Maximum speed of this machine is 6,000 stitches per minute. For the first 100 actual working hours, however, the new machine should be operated at about 5,000 s.p.m. so that all the working parts are well run-in. After this running-in period, you may operate the machine at maximum speed of 6,000 stitches per minute. This is desirable for machine's long life.

#### B. Motor, motor pulley and belt.

- 1) Use a clutch motor, 1/2 Hp, 2 pole, single or three phase. Our motor available is Models MD-344 (single phase) and MD-354 (three phase)
- 2) Use M-type V-belt.
- 3) Machine speed (s.p.m.), diameter of motor pulley and length of motor belt is related to the following table.

Stitches per minute	Outside diameter of pulley and length of V-belt			
	50 Hz		60 Hz	
	Pulley	V-belt	Pulley	V-belt
5,200	115mm	39inch	95mm	38inch
5,500	120 "	39 "	100 "	38 "
6,000	130 "	39 "	110 "	38 "

#### C. Setting up

This machine is normally set up as semi-submerged type.

Necessary parts and accessories for setting up this machine are contained together with the machine head.

If you have purchased this machine as head only, make the table top as per attached table sheet, also refer to Fig. 1, which shows the parts necessary for setting up this machine and also the measurement to mount the bottom board to the table top as semi-submerged type.

With our Brother clutch motor, Models MD-344 and MD-354, there is no anxiety to set the machine to the bottom board, however, if you would use with other brand clutch motor, please make sure to have proper holes on the bottom board.

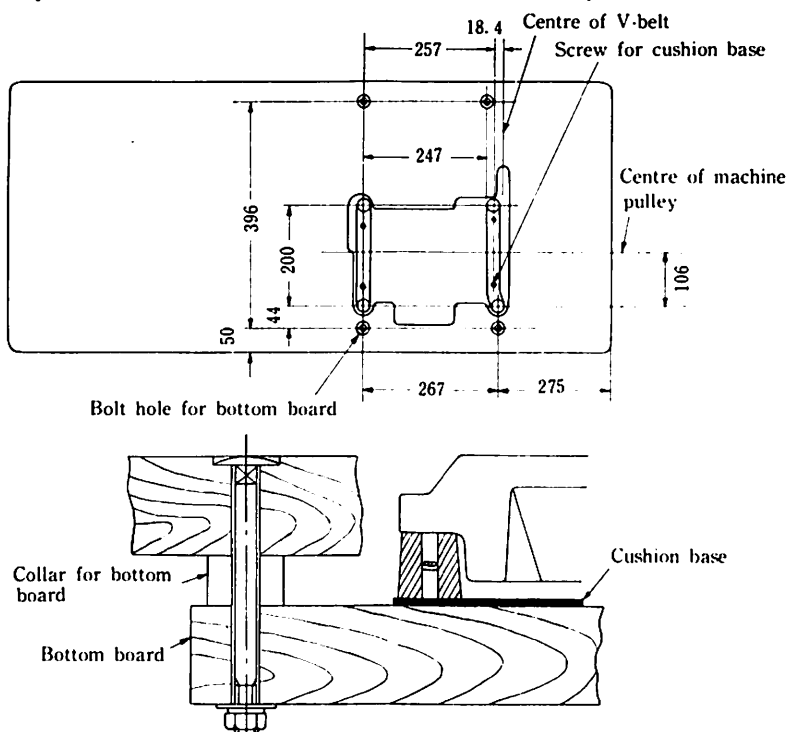

Figures are in millimeter (Fig. 1)

#### D. Oiling, draining and maintenance.

Oil is drawn out of the machine prior to its shipment.

Before operating the machine, therefore, remove the oil filter cap (shown in Fig. 2) and pour oil into the machine using the funnel.

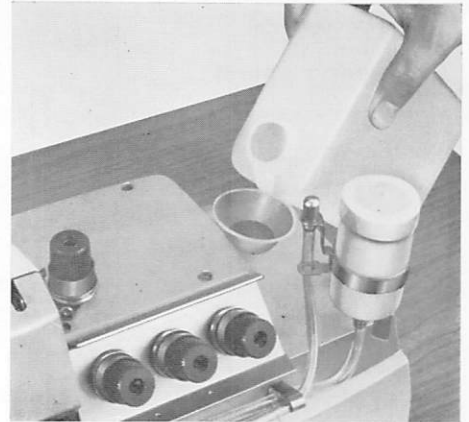

(Fig. 2)

Oil level should be up to the upper line of the oil gauge shown in Fig. 3. The oil reservoir consists of two tanks partitioned by a filter, so it takes sometime before the oil levels of both tanks match. Check if oil is up to the required level a little after the oil is poured. Add oil if oil level is below the upper line of the oil gauge.

Be sure to check the oil gauge for oil level before operating the machine.

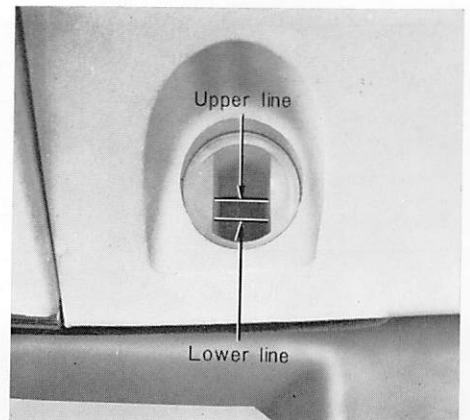

(Fig. 3)

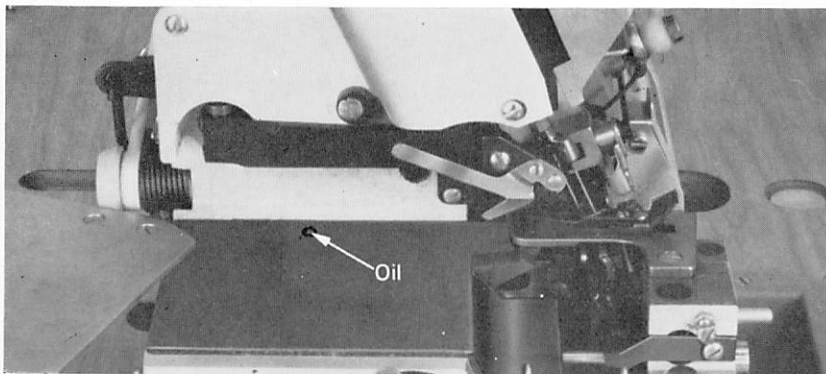

(Fig. 4)

When operating the machine for the first time after unpacking it or after it has been out of oil for a long period of time, add 5 or 6 drops of oil into the oiling points shown in Fig. 4, and 5. You do not have to add oil into them if the machine is operated daily.

At the end of 100 hours actual operation, running-in period, change the oil. Thereafter, change it once in about three months use.

The quantity of oil required is about 800~1,000cc. Remove the screw shown in Fig. 6. for draining oil.

The machine employs a geared pump for the forced lubrication to its major moving parts. It is recommended that the oil reservoir be dismounted about twice a year for cleaning of its inner surfaces, pump, wire gauze, etc. This is desirable for long life of the machine.

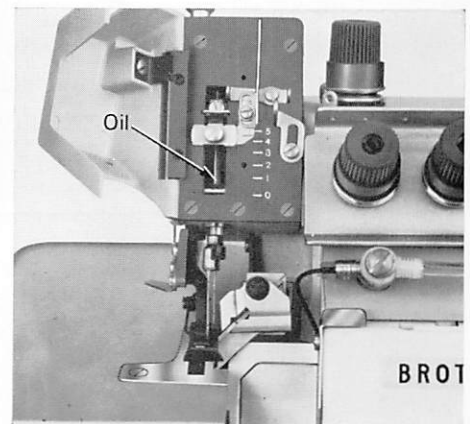

(Fig. 5)

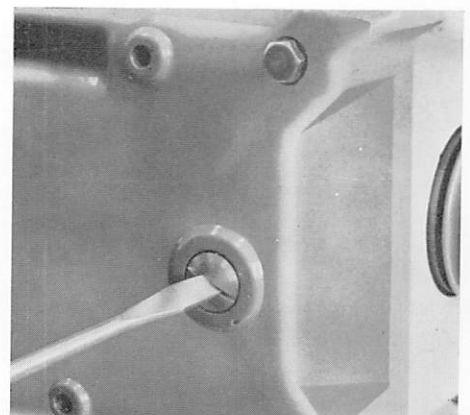

(Fig. 6)



## E. Needle cooler device

With machine model "—C", it is equipped with the needle cooler device.

In order to get the good sewing result on the synthetic materials and resin treated materials such as polyester, jersey, and tricot, etc., or with the synthetic threads, such as Nylon and Dacron, it will be advantageous to use the needle cooler device.

### 1. Operating procedure

- 1) Pour the silicone oil into the tank approximately 4/5 in capacity (50cc in capacity) then open the cock shown in Fig. 7.
- 2) If this machine is brand new or after it has been out of use for long time, it takes about 10-15 minutes to saturate the silicone oil into the felt on the needle guard, then apply several drips of silicone oil on the felt so as to thoroughly saturate before sewing operation.
- 3) The cock must be closed when the machine do not require the silicone oil, namely on the slow speed operation or cotton thread, cotton materials applied and also when you do not use the machine.

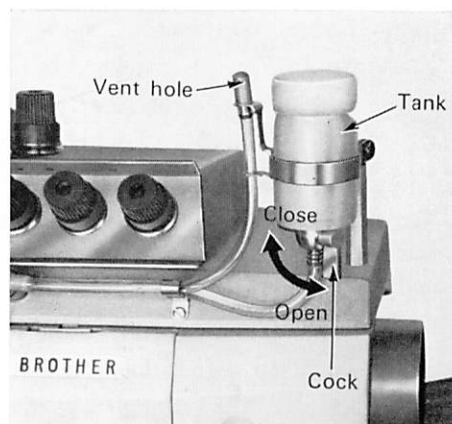

(Fig. 7)

### 2. Sewing capability with needle cooler

When you would sew the synthetic materials, jersey, tricot, etc., it can be ensured to sew upto 6 plies of such materials at the high speed of 6,000 stitches per minute.

### 3. Silicone oil to be used

Silicone oil . . . . . Viscosity; 500cs

50cc silicone oil could be operated approximately half a month of sewing operation although it depends on the sewing work.

### 4. Proper installation on the machine

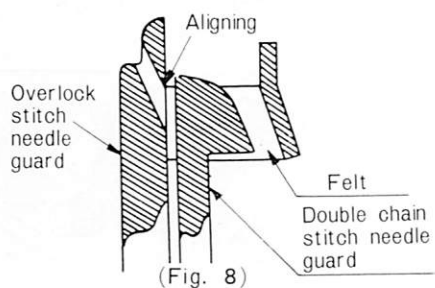

(Fig. 8)

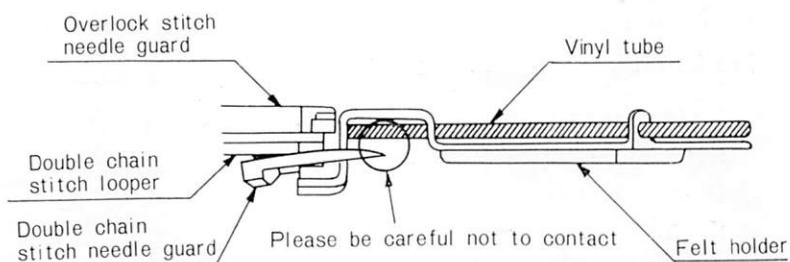

(Fig. 9)

- 1) The top of the felt must be aligned with the top of the groove of over looper needle guard.(Fig. 8)

In this case, please be careful to set up so that the double chain stitch looper may not contact to the tube.

#### 2) Position of tank

The position of the tank should be set up at the position that the Vent hole is higher than the oil level as shown in Fig. 7.

#### 3) Removal of the top cover

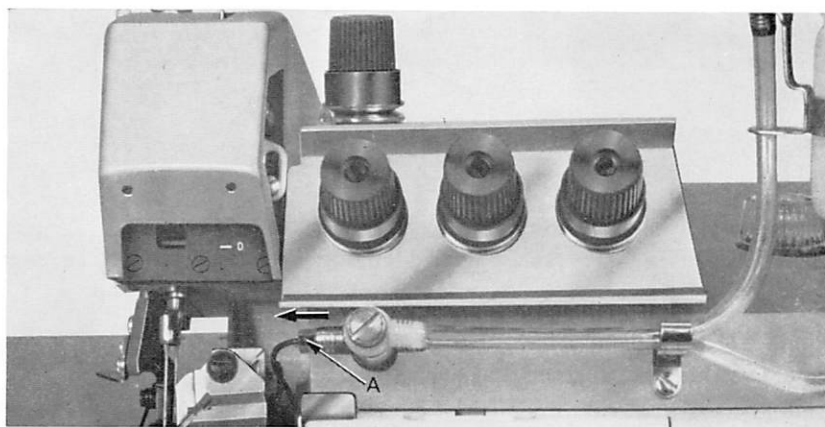

(Fig. 10)

When you pull the tube Point A to the left as per Fig. 10, the tank and felt portions will be separated, thus the tank can be detachable together with top cover.

## F. Machine operating direction

The proper operating direction of this machine is clockwise as viewed from the pulley side.

## G. Installing needles

Turn the pulley until the needle bar is raised to its highest position, lower the lifter level (A) shown in Fig. 11, pressing by the thumb finger and move the presser foot arm (B) to the direction as indicated with arrow mark. Now, loosen the needle set screws and holding the needles with their grooved side facing toward you, then insert them into the needle clamp holes all the way up checking the holes in the needle clamp whether these needles are all the way up. After this check, tighten the screws.

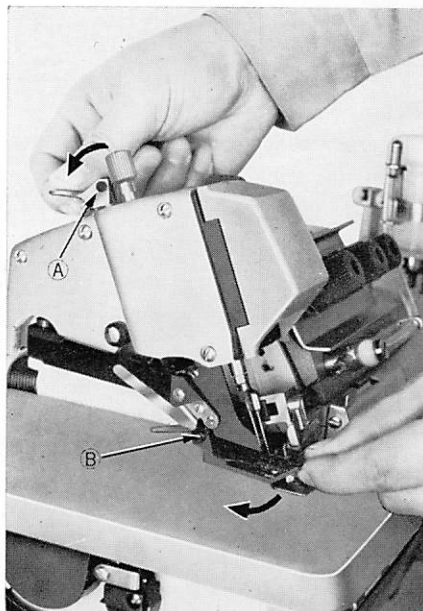

(Fig. 11)

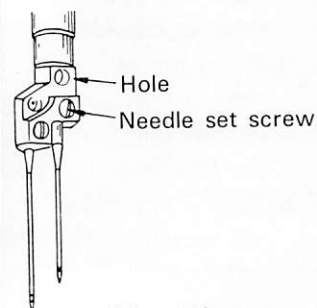

(Fig. 12)

## H. Threading

Pass the threads through the eyes of the cotton stand then please do in the following order; 1. Under looper 2. over looper 3. double chain stitch looper 4. overlock stitch needle 5. double chain stitch needle.

Before passing these threads, open the front cover, cloth plate and thread take-up cover, turn the pulley until the needles are at the highest position, and move the presser foot arm outward. Pass the threads as shown in Fig. 13.

- ① Under looper thread
- ② Over looper thread
- ③ Double chain stitch looper thread
- ④ Overlock stitch needle thread
- ⑤ Double chain stitch needle thread

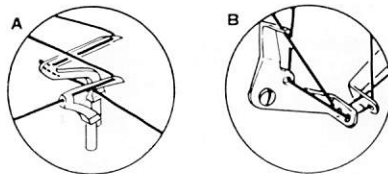
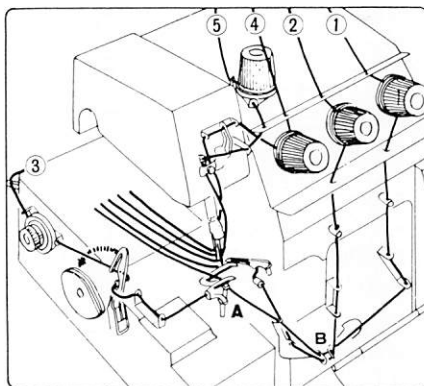

(Fig. 13A)  
For five threads

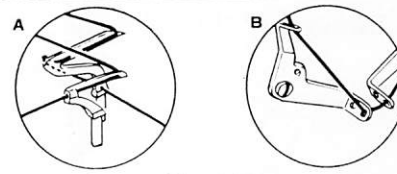
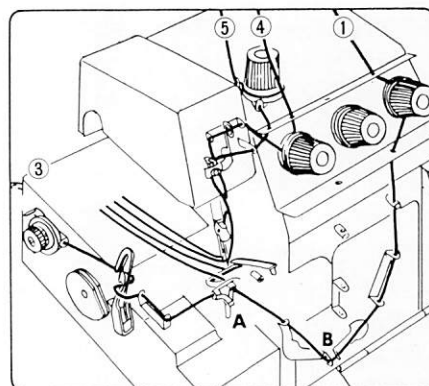

(Fig. 13B)  
For four threads

When you thread to the eyes of thread guides, loopers, and needles, please use with the tweezers in the accessory box.

### (Note)

Draw out the thread approximate 5cm from the tip of looper.

Care should be taken for threading of four threads and five threads because of difference between both cases as shown in Figure 13A and 13B.



## I. Stitches

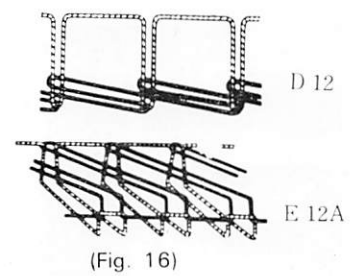
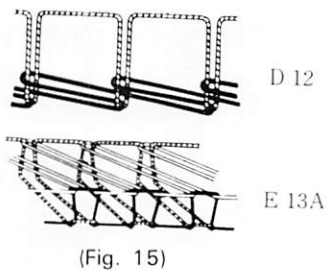
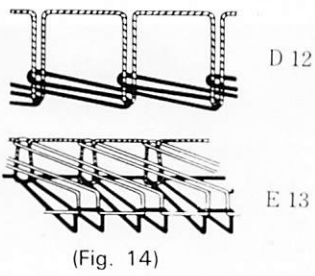

For five threads specification, parallel stitching of D12 and E13 combination is arranged upon adjusted (Figure 14), but rearrangement parallel stitching of D12 and E13A combination (Figure 15) could also be accomplished upon adjustment with turning the adjusting screw.

For four threads specification, parallel stitching of D12 and E12A combination (Figure 16) is arranged upon appropriate adjustment.

In case of the E13/D12 combination, the over looper needle thread and double chain stitch needle thread have the strongest tension, followed by the under looper thread tension and then the over looper and double chain stitch looper threads tension.

In case of the E12A / D12 or E13A/D12 combination, the double chain stitch threads tension remain the same, however, the overlock stitch thread's tension must be changed. In this case, the under looper thread has the strongest tension, followed by the over looper thread tension and then overlock needle thread tension.

## J. Thread tension

Thread tension may change depending on the type of thread and material sewn, stitch width, stitch length the positions of the thread take-up and thread guides. If it should change considerably, make adjustment in the following manner

### 1. Adjustment of thread take-up

Needle thread will be ease to be tightened if the thread take-up is lowered and be ease to be loosened if the thread take-up is raised up on the contrary.

The thread take-up in the middle position is the standard thread tension. (Fig. 17)

Figure A will be applied to a thread take-up for five threads specification, and Figure B will be applied to a thread take-up for four threads specification.

### 2. Adjusting double chain stitch needle thread guide:

To tighten the needle thread, raise the double chain stitch needle thread guide. To loosen it, lower the guide. The guide in the middle position is the standard thread tension. (Fig 17)

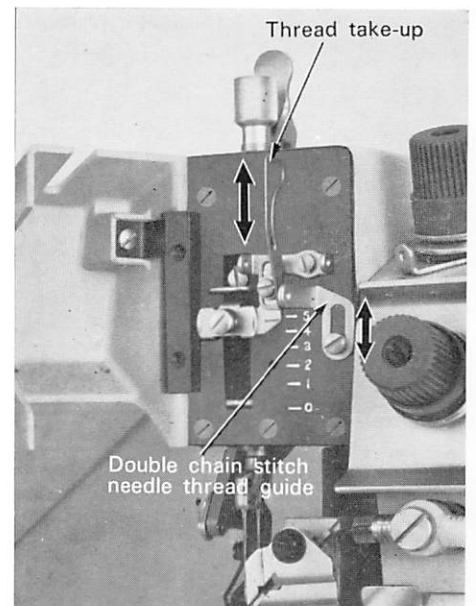

(Fig. 17)

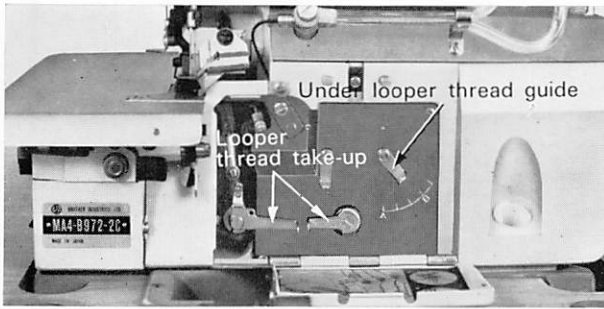

Fig. A

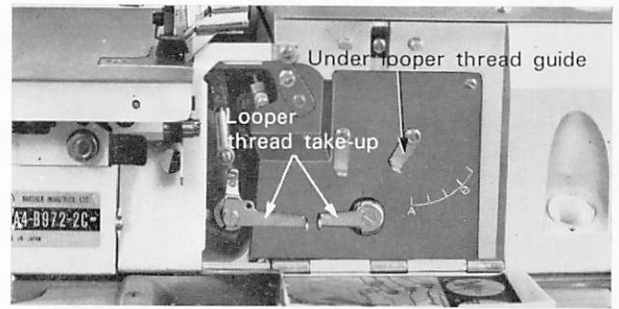

Fig. B

**3. Adjusting looper thread take-up and thread guide for overlock stitch :**



(Fig. 18)



(Fig. 19)

As shown in Fig. 18 at the highest position of the needle, it is the standard position of the looper thread take-up and thread guide, for the three threads overlock stitch.

In this case, the position of under looper thread guide shows in B is for cotton thread and A for synthetic thread. As shown in Fig. 19, at the highest position of the needle, it is the standard position of the looper thread take-up and thread guide, for the two threads overlock stitch.

**4. Adjusting looper thread take-up and thread guides for double chain stitch :**

As shown in Fig. 20, at the highest position of the needle, it is the standard position of the double chain stitch looper thread take-up and thread guides.

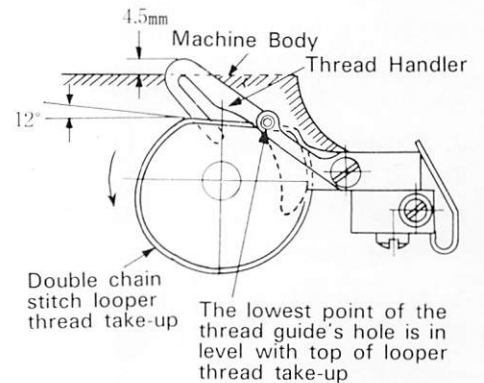

(Fig. 20)

**5. Adjusting thread tension screws :**

After completion of the above-mentioned adjustment of the thread guides and thread take-up, turn the thread tension screws for fine adjustment.

Incorporate an appropriate adjustment for the above "stitches" (Page 7).

Be careful not to turn the screw in or out excessively, because it may tighten the threads more than necessary or cause the thread take-up to feed the threads too excessively

**K. Adjustment on the pressure of presser foot : Installing or removing feed dogs · and Height of feed dogs:**

The pressure of the presser foot can be adjusted by means of the presser foot adjusting screw shown in Fig 21



(Fig. 21)

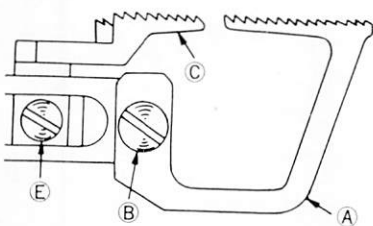

(Fig. 22)

Follow the instructions given below to install or remove the feed dogs: (Fig. 22)

To install the differential feed dog A, tighten the screw B.

To install the main feed dog C, tighten the screw E.

The standard height of the feed dogs is such that when the overlock needle point comes to a point 1 mm to top surface of the needle plate in its upward travelling, the top of the feed dogs is level with the surface of the needle plate. (Fig. 23)

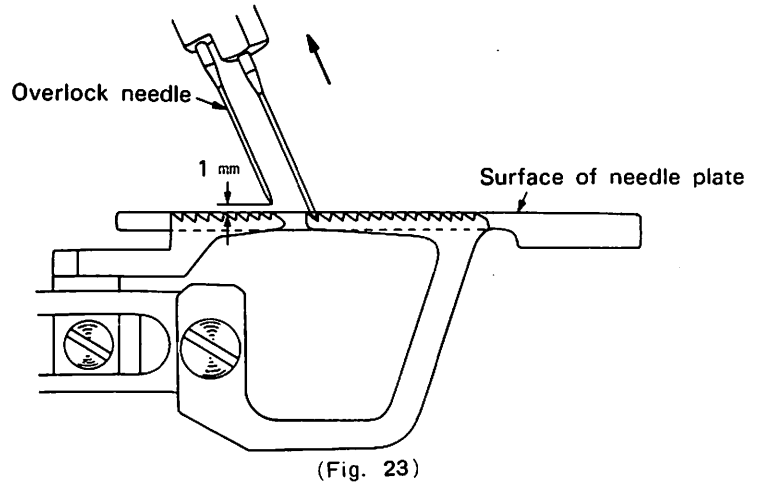

#### L. Adjusting stitch width (overedge bight)

Stitch width is dependent on cloth trimming width and the tongue of the needle plate.

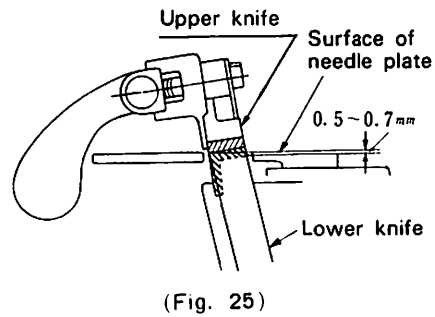
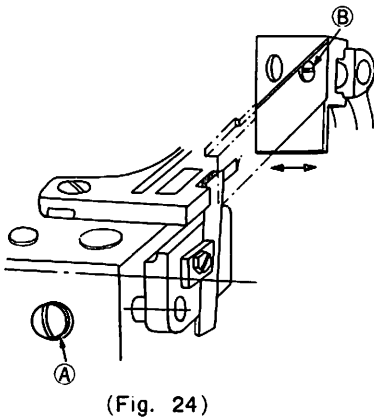

Adjust the trimming width as follows: (Fig. 24)

- 1) Remove the upper knife.
- 2) Tighten the set screw **A** temporarily so that the lower knife may come to the point where desired trimming width may be obtained.
- 3) Loosen the screw **B** and adjust the contact of the upper and lower knives as shown in Fig. 25 by moving the upper knife holding block to either left or right.
- 4) Tighten the screw **B** and install the upper knife while pressing it to the lower knife.
- 5) Loosen the set screw **A** and please make sure that the lower knife may contact with upper knife by the spring pressure.

Fix the lower knife by tightening the set screw **A**.

### M. Adjusting stitch length

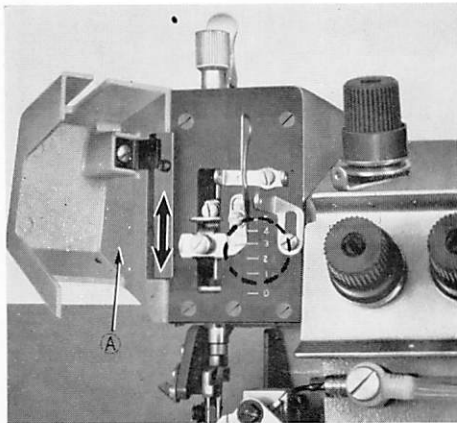

(Fig. 26)

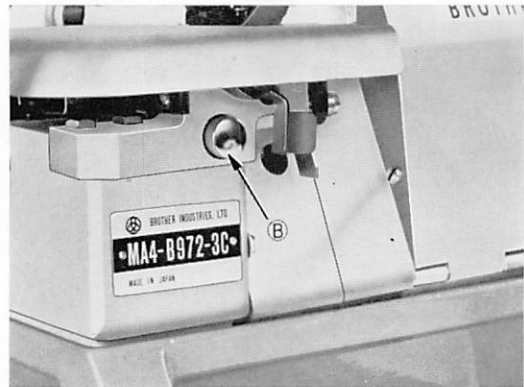

(Fig. 27)

Stitch length can be adjusted to any point within the range from 1.7mm to 3.6mm. At first, open the needle thread take-up cover (A). (Fig. 26) Then, with the push-button (B) (Fig. 27) located in front of the machine kept depressed, turn the pulley slowly in the normal operating direction. The push-button goes inward as the pulley is turned. Stop the pulley when the pointer reaches the number representing your desired stitch length, and release the push-button. The numbers indicates the stitch length, however, the actual stitch length may change depending on the kind of the materials, their thickness and differential feeding.

### N. Adjusting differential feed.

Differential feed may be adjusted to stretch, be normal or gather by loosening the screw (A) shown in Fig. 28A and moving the lever up or down as required. Normal feed is obtained by setting the lever's mark is in line with the mark on the scale. If the lever is lifted up, namely to (-) sign, you will get gathering If down, to (+) sign, you will get stretching. After adjustment is completed, please make sure to tighten the screw (A) securely.

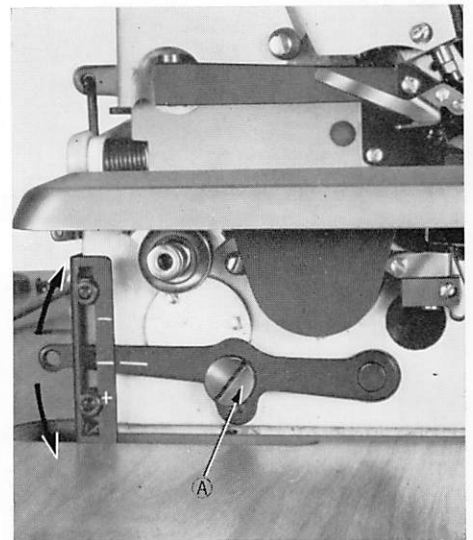

(Fig. 28A)

In the case to require larger gathering differential feed.

Remove cloth plate and feeding mechanism cover, loosen nut (A) of main feed link shaft by an attached wrench, then lower downward. (Figure 28B) When the main feed link shaft is lowered until bottoming, the differential ratio will become as follows.

Differential adjusting lever, upper end.....Differential ratio, 2.5.

Differential adjusting lever, lower end.....Differential ratio, 1.3.

When a medium differential ratio is required, place and settle the main feed link shaft at an intermediate position in the groove of main feed arm.

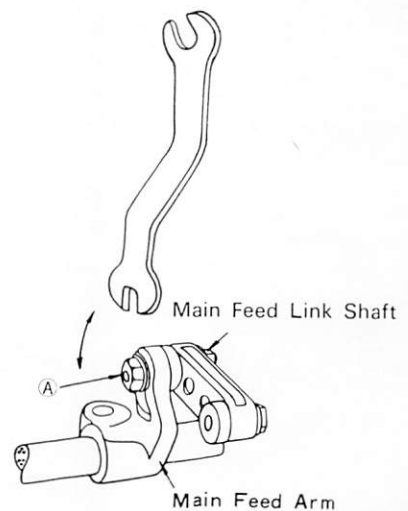

(Fig. 28B)

## 4. Adjustment

### A. Height of needles (Fig. 29)

For needle replacement, please follow the chapter describing the correct installation of the needles. When the needles are at the highest position, the overlock needle should be 11.0 mm over the surface of the needle plate, and at that time, the double chain stitch needle, about 7.8 mm.

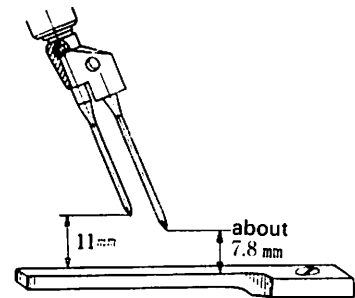

(Fig. 29)

### B. Relation between needle and under looper (Fig. 30)

When the under looper is at its left extremity, the distance between the point of the under looper and the centre of right needle is 4.0 mm.

The under looper is determined its height when it is inserted all the way into the looper holder. The relation between the point of the under looper and the needle in its upward travelling is shown in Fig. 30.

When the point of the under looper is going to pass the back of the needle, which is in its downward travelling, the clearance between needle and point of the under looper is about less than 0.1 mm.

The under looper should be installed as being provided 1.5mm of inclination.

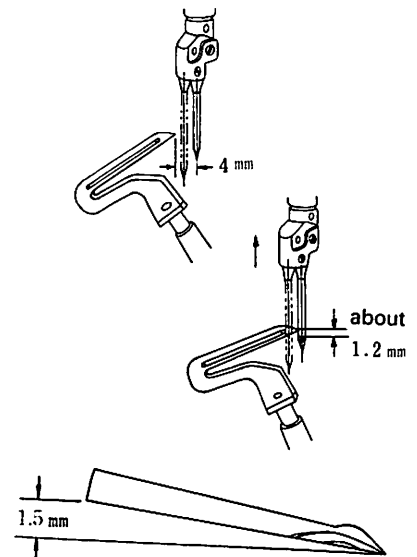

(Fig. 30)

### C. Installing needle guard (for overlock stitch) (Fig. 31)

Push the needle with the needle guard to such an extent that when the point of the under looper comes to the centre axis of the needle on its way up, they are barely out of contact with each other and install the needle guard in that position.

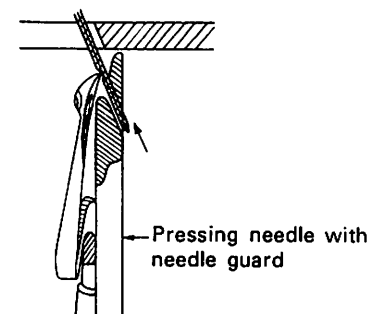

(Fig. 31)

### D. Matching needle guard and needle. (for overlock stitch) (Fig. 31)

Use the needle guard and needle in the following combination.

Needle guard	Size of needle
No. 2	#11
No. 3	#14, #16
No. 4	#18, #19

**E. Relation of needle with under looper and over looper**

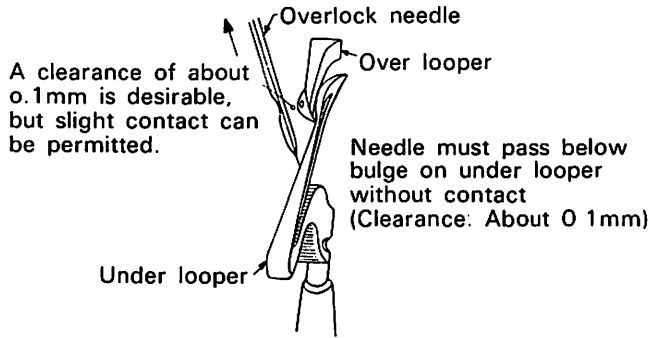

(Fig. 32)

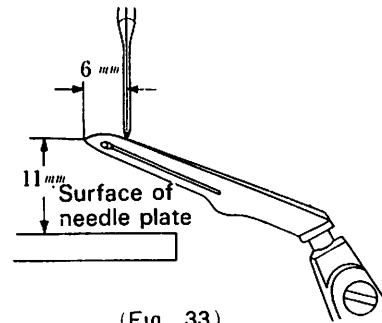

(Fig. 33)

After determining the relative position of the needle and under looper mentioned in B, position the over looper properly as shown in Fig. 32. & 33.

Fig. 33 shows the measurement of the over looper setting, for your reference.

**F. Relation between needle and double chain stitch looper. (Fig 34 & 35)**

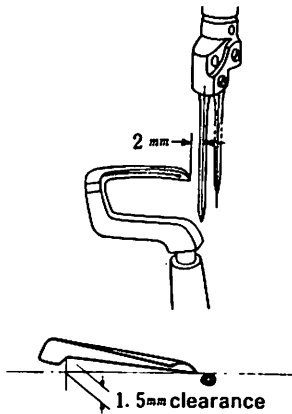

(Fig. 34)

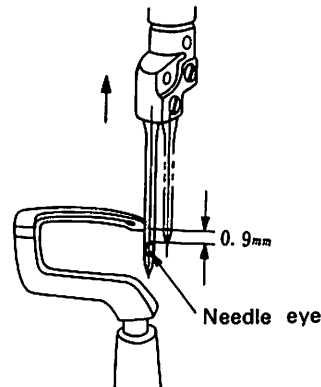

(Fig. 35)

When the double chain stitch looper is at the left extremity, the distance between its point and the centre of the needle for double chain stitch is about 2.0 mm. At that time, the double chain stitch looper should be set with the clearance of about 1.5 mm between recess portion of the looper and needle plate holder

The looper is determined its height when it is inserted all the way into its holder. The relation between the double chain stitch looper and the needle eye on its upward travelling is as shown in Fig. 35.

There should be as little clearance as possible between needle and looper point when the point is going to pass the back of the needle on its way up.



### G. Installing double chain stitch needle guard (Fig. 36)

Install the needle guard in such a position that when the looper passes the back of needle as the needle rises from its lowest position needle guard may not contact the needle pressing lightly the needle by finger. If the correct adjustment is not made, skip stitch or needle breakage may be caused when sewing on materials pulling or in case of sewing folded part.

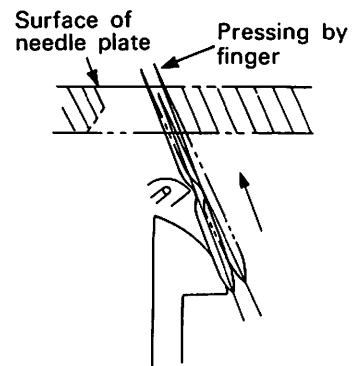

(Fig. 36)

### H. Installing and maintenance of knives (Fig. 37)

Mount the lower knife to the lower knife holder so that its edge is in level with the needle plate. Install the upper knife so that its front edge is 0.5–0.7mm below the edge of the lower knife when it is at the lowest end of its stroke as shown in Fig. 37.

The upper knife is fitted with a tungsten-carbide tip, which can be ground only with diamond grinding wheel. It lasts its original sharpness for a long period without re-sharpening. Sharpen the lower knife when necessary. Fig. 38 shows the shape of lower knife.

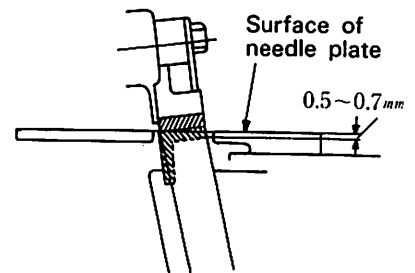

(Fig. 37)

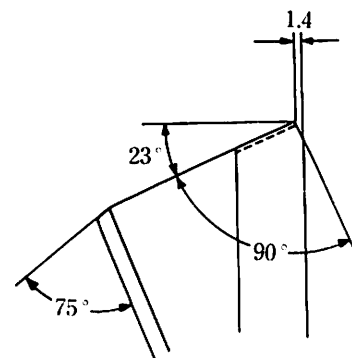

(Fig. 38)

## 5. Trouble shooting

### A. Thread breaks

Cause	Remedy
Poor thread quality.	Use thread of good quality.
Thread too thick for needle size.	Change needle or thread for the right one.
Needle groove or needle eye poorly finished.	Change needle for a good one.
Excessive pressure of tension disc.	Adjust to proper pressure.
Needle improperly fitted.	Refer to instructions for "Installing needles." (Page 6)
Needle, looper, needle plate, or thread passage has flaws.	Smooth surface with oil stone or buff.
Relation of needle with looper and thread take-up not right.	Refer to "Thread tension." (Page 7)
Wrong threading.	Refer to "Threading." (Page 6)
Needle gets hot.	Use with needle cooler or use smaller size needle.

### B. Skip stitching

Cause	Remedy
Wrong threading.	Refer to "Threading." (Page 6)
Point of looper out of shape.	Reshape with oil stone or replace.
Needle point blunt or bent.	Replace.
Needle improperly fitted.	Refer to "Installing needles." (Page 6)
Relation of needle with looper and thread take-up or clearance between them not right.	Refer to "Thread tension" and "Adjustment." (Pages 7 & 11)
Needle and needle guard out of proper relation.	Refer to "Installing needle guard." (Page 11)
Needle gets hot.	Use with needle cooler or use smaller size needle.
Pressure of tension disc too small.	Adjust to proper pressure.

### C. Needle breaks

Cause	Remedy
Needle and needle guard out of proper relation.	Refer to "Installing needle guard", "Matching needle guard and needle" and "Installing double chain stitch needle guard." (Page 11)
Needle and looper out of proper relation.	Refer to "Relation between needle and under looper" and "Relation of needle with under looper and over looper." (Pages 11 & 12)
Needle bent.	Replace.
Needle improperly fitted.	Refer to "Installing needles." (Page 6)

**D. Imperfect chaining-off  
(overlock stitch)**

Cause	Remedy
Wrong threading.	Refer to "Threading." (Page 6)
Stitch tongue on needle plate has flaw.	Smooth with emery paper and polish with buff.
Looper thread take-up and thread guide out of position.	Refer to "Thread tension" (Page 7)
Chain feed dog improperly installed.	Refer to "Adjustment on the pressure of presser foot; Installing or removing feed dogs; and Height of feed dogs." (Page 8)
Threads too tight.	Adjust to proper tension.

**(Double chain stitch)**

Cause	Remedy
Wrong threading.	Refer to "Threading." (Page 6)
Needle thread and looper thread have tension too strong or too weak.	Adjust to proper tension.
Differential feed dog not in level with main feed.	Refer to "Adjustment on the pressure of presser foot; Installing and removing feed dogs; and Height of feed dogs." (Page 8)
Needle thread guide out of position.	Refer to "Thread tension." (Page 7)
Lower thread take-up out of timing.	Refer to "Thread tension." (Page 7)

**E. Improper thread tension**

Cause	Remedy
Relation of needle with looper and thread take-up not right.	Refer to "Adjustment" and "Thread tension." (Page 7 & 11)
Tension disc will not work properly.	Clean tension disc of foreign particles to allow smooth operation.
Thread too thick for needle.	Use needle or thread of the right size.
Wrong threading.	Refer to "Threading." (Page 6)

**F. Poor trimming performance**

Cause	Remedy
Lower knife worn out.	Re-sharpen.
Upper and lower knives installed improperly.	Refer to "Installing and Maintenance of knives." (Page 13)
Spring pressure on lower knife not right for materials to be trimmed.	Refer to "Installing and Maintenance of knives." (Page 13)

### G. Irregular stitches

Cause	Remedy
Wrong threading.	Refer to "Threading." (Page 6)
Thread irregular in thickness.	Use thread of good quality.
Thread passage rough.	Smoothly polish.
Thread take-up and thread guide out of position.	Refer to "Thread tension." (page 7)
Knives blunt.	Refer to "Installing and Maintenance of knives." (Page 13)
Lower knife installed improperly.	Refer to "Installing and Maintenance of knives." (Page 13)

### H. Excessive wrinkles along stitches

Cause	Remedy
Differential feed needs adjustment.	Refer to "Adjusting differential feed." (Page 10)
Pressure of presser foot not right.	Adjust to proper pressure.
Thread tension too strong.	Adjust properly.
Feed dogs installed improperly.	Refer to "Adjustment on pressure of presser foot; Installing and removing feed dogs; and Height of feed dogs." (Page 8)
Knives blunt.	Refer to "Installing and Maintenance of knives." (Page 13)
Cloth trimming width and stitch tongue of needle plate out of proportion.	Adjust trimming width to needle plate or replace needle plate.
Needle too thick.	Use needle proper for materials and thread.

### I. Needle produce too large holes

Cause	Remedy
Needle point blunt.	Replace needle.
Needle too large for materials.	Use smaller size needle.
Needle gets hot.	Use needle cooler.

## PARTS LIST for MA4-B972

### INDEX

Parts. No.	Ref. No.	Remark	Parts. No.	Ref. No.	Remark	Parts. No.	Ref. No.	Remark	Parts. No.	Ref. No.	Remark
001401-4-06	Z-28		100541-0-02	F-36		110821-0-01	G-60		140097-0-01	B-2	
003670-6-14	C-47		100541-0-03	A-5		110832-0-01	G-28		140098-0-01	B-25	
"	D-11		"	F-10		"	G-36		140099-0-01	B-28	
"	G-41		100579-0-02	D-21		"	G-63		140100-0-01	B-29	
005660-7-13	D-10		100644-0-03	A-84		111104-0-01	D-97		140102-0-01	G-3	
009669-3-13	G-5		100645-0-03	E-70		111443-0-01	A-97		140103-0-01	G-1	
009670-5-14	G-82		101275-0-04	G-55		"	C-17		140104-0-16	B-35	
009670-5-16	A-106		101552-0-01	B-62		"	C-30		140105-0-02	B-58	
009671-6-03	C-49		101572-0-01	Z-10		111486-0-01	E-47		140106-0-01	B-54	
009680-8-12	H-64		101706-0-01	A-45		111865-0-01	B-56		140108-0-02	J-19	
009681-0-14	A-20		"	D-26		112297	A-96		140108-0-03	B-63	
009681-2-12	D-87		"	H-54		112297-0-16	Z-20		140109-0-01	A-25	
009682-0-14	A-22		101795-0-01	Z-22		112299-0-01	B-36		140110-0-00	A-26	
009689-4-12	H-63		102338-0-06	A-49		112300-0-01	G-7		140111-0-01	C-32-34	
009711-0-13	C-24		102629-0-04	Z-9		112301-0-01	G-6		140112-0-00	C-8	
013750-6-14	E-67		102716-0-03	G-57		112348-0-01	G-8		"	C-34	
017751-4-13	C-16		102843-0-04	A-10		"	A-93		"	E-18	
"	E-45		"	A-11		"	H-5		140113-0-01	C-32	
017771-4-12	D-14		104215-0-01	E-55		"	H-17		140114-0-01	C-19	
"	D-23		104449-0-01	A-36		"	H-18		140115-0-01	C-41	
"	B-16		104521-0-01	D-27		"	H-22		140116-0-00	C-1	
"	C-5		"	H-53		"	H-25		"	C-26	
"	C-31		104564-0-01	I-12		"	I-15		140117-0-01	C-38	
"	C-51		104651-0-01	C-46		112351-0-01	B-9		140118-0-00	C-13	
"	D-10		104832-0-01	A-46		"	H-26		140119-0-01	C-44	
"	D-55		"	A-63		112359-0-01	H-21		140120-0-01	C-45	
"	E-15		104833-0-01	H-12		112364-0-01	H-13		140121-0-01	C-49	
"	E-26		104908-0-01	E-40		"	H-27		140122-0-01	C-50	
"	F-26		105034-0-02	C-10		112467-0-01	H-30		140124-0-01	C-21	
017782-0-14	B-60		"	C-36		113431-0-02	A-94		140125-0-01	C-23	
017822-2-10	A-88		"	E-17		114294-0-01	B-65		140127-0-01	C-48	
021770-1-03	E-12		105078-0-01	B-22		114447-0-01	J-6		140128-0-01	C-46-50	
022710-1-03	E-35		105079-0-01	B-19		"	"		140129-0-01	C-6-8	
021080-1-06	Z-35		105123-0-01	G-44		114483-0-01	Z-14		140130-0-01	C-6	
025080-3-36	Z-33		105163-0-01	D-29		116016-0-01	Z-27		140131-0-01	E-18-20	
025350-3-32	H-50		105173-0-03	H-46		116231-0-01	A-59		140134-0-01	F-20	
028080-2-43	Z-34		105228-0-01	G-59		116662-0-01	D-59		140135-0-01	E-29-31	
031451-6-03	Z-24		105230-0-01	G-58		116778-0-01	C-3		140136-0-01	F-29	
048020-3-42	F-53		105234-0-01	E-52		"	C-27		140137-0-00	F-31	
048050-3-47	I-31		105248-0-01	G-80		117127-0-02	B-67		140138-0-01	E-9	
048080-3-46	F-30		105343-0-01	Z-3		117437-0-01	Z-26		140139-0-01	E-28	
048150-1-43	D-105		105344-0-01	Z-8		117466-0-00	Z-11		140140-0-01	F-31	
072600-0-30	B-30		105387-0-01	C-20		117515-0-01	E-56		140141-0-01	E-5-7	
081004-0-70	I-29		106069-0-01	C-25		117516-0-01	E-57		140143-0-00	E-6	
100016-0-03	B-49		"	F-39		117666-0-01	B-31		140145-0-00	E-11	
100025-0-01	D-106		106129-0-01	B-61		"	J-2		140146-0-01	E-14	
100032-0-01	A-40		106812-0-01	Z-25		118527-0-01	E-53		140148-0-01	E-13	
"	B-55		107093-0-02	D-108		"	Z-18		140149-0-01	E-8	
100035-0-02	G-14		"	D-112		120823-0-01	E-51		140150-0-00	E-36	
100080-0-03	E-33		107231-0-01	F-56		140032-0-01	A-32		140151-0-00	E-37	
100130-0-01	A-18		107244-0-01	B-52		140033-0-01	A-31		140152-0-01	A-7	
"	F-12		107272-0-02	A-28		140036-0-01	A-6		140153-0-01	E-2	
100137-0-01	H-49		107351-0-01	B-59		140037-0-02	A-13-17		140156-0-01	F-39	
100137-0-02	A-38		107407-0-02	D-86		140038-0-02	A-16		140157-0-01	E-11	
"	B-61		107491-0-02	G-47		140039-0-01	A-13		140158-0-00	E-38	
100137-0-03	G-18		107779-0-01	Z-5		140040-0-01	A-17		140159-0-00	E-42	
100176-0-01	E-4		108721-0-01	G-27		140041-0-01	A-15		140160-0-01	E-46	
100185-0-03	A-21		"	G-35		140043-0-01	A-9		140161-0-01	F-48	
"	A-55		"	G-62		140045-0-01	A-37		140165-0-01	D-100	
"	H-1		108962-0-01	Z-6		140048-0-00	A-39		140176-0-01	D-98	
"	H-11		"	Z-19		140054-0-02	A-81		140178-0-01	D-9	
100185-0-04	A-51		109203-0-01	A-89		140055-0-01	A-83		140179-0-01	D-8	
"	A-62		109571-0-01	D-79		140056-0-01	A-82		140180-0-01	B-44	
"	A-69		109836-0-01	D-17		140057-0-01	A-77		140182-0-01	D-78	
"	A-74		110161-0-03	F-38		140058-0-01	A-76		140183-0-01	D-80	
"	A-75		"	L-27		140060-0-01	A-102		140184-0-01	D-7	
"	A-78		110161-0-04	D-2		140063-0-01	B-57		140185-0-00	D-6	
"	G-2		110191-0-01	L-26		140064-0-01	A-27		140186-0-00	D-24	
"	G-9		110436-0-01	Z-1		140065-0-01	A-23		140187-0-00	A-47	
"	G-21		110495-0-01	A-44		140066-0-01	A-52		140188-0-03	A-48	
"	G-52		110641-0-01	A-90		140067-0-01	A-92		140189-0-01	D-36-37	
"	I-9		110671-0-00	B-49		140071-0-01	A-87		140190-0-01	D-37	
"	I-20		110668-0-01	B-39		140072-0-01	A-85		140191-0-01	D-38	
100215-0-00	D-109		110670-0-00	B-48		140075-0-01	A-53		140193-0-01	D-89	
100242-0-02	A-14		110672-0-00	B-50		140077-0-01	A-86		140194-0-01	D-88	
100251-0-01	D-95		110673-0-00	B-51		140083-0-01	A-61		"	K-15	
100250-0-01	B-4		110686-0-01	B-15		140084-0-00	B-43		140196-0-01	D-81	
100264-0-04	B-66		"	E-10		140085-0-02	B-45		140197-0-01	D-84	
100289-0-01	C-2		"	E-23		140088-0-01	B-68		140202-0-01	D-28	
100289-0-03	C-28		110701-0-01	C-9		140089-0-01	B-69		140203-0-01	D-39	
100366-0-01	B-9		"	C-35		140090-0-01	B-7		140205-0-01	D-22	
"	B-13		110706-0-01	C-14		140091-0-00	B-17		140207-0-01	D-35	
"	E-21		110720-0-01	E-32		140092-0-01	B-8		140208-0-01	D-32	
100368-0-02	B-47		110735-0-01	A-8		140093-0-01	B-3		"	D-45	
100469-0-02	A-56		110778-0-01	E-1		140094-0-01	B-24		140209-0-01	D-36	
100539-0-03	D-51		110793-0-01	F-32		140095-0-01	B-1		140210-0-01	D-34	
100541-0-01	B-20		110813-0-01	G-29		140096-0-01	B-26		140211-0-01	D-16-19	
"	H-15		"	G-66		"	"		"	"	
"	D-1		110820-0-01	G-30		"	"		"	"	
"	E-44		"	G-37		"	"		"	"	

## INDEX

Parts. No.	Ref. No.	Remark	Parts. No.	Ref. No.	Remark	Parts. No.	Ref. No.	Remark	Parts. No.	Ref. No.	Remark
140212-0-01	D-16		140727-0-01	A-101. 102		143179-0-01	B-40		145284-0-01	D-95 ~ 113	
140213-0-01	D-19		140736-0-01	K-1		143182-0-01	B-41		145285-0-01	D-101	
140214-0-01	D-18		140738-0-01	Z-31		143280-0-01	J-18		145286-0-01	D-99	
140215-0-01	D-44		140739-0-01	Z-32		"	L-5		145288-0-01	D-107	
140216-0-01	D-43		140756-0-01	G-65		143282-0-01	L-5		145289-0-01	D-110	
140217-0-01	D-46		140758-0-01	A-91		"	K-17		145290-0-01	D-111	
140226-0-01	D-58		140759-0-00	Z-17		143284-0-01	A-58		145638-0-01	B-68 ~ 72	
140228-0-01	D-4		140764-0-01	H-3		"	L-5		145640-0-01	B-71	
140229-0-01	D-5		140768-0-01	H-23		143286-0-01	G-64		145651-0-01	B-73	
140230-0-01	E-21 ~ 25		140771-0-01	D-31		143287-0-01	D-60		145663-0-01	D-113	
140231-0-00	E-22		140772-0-01	D-41		143292-0-02	A-21		145664-0-00	A-103	
140232-0-01	E-24		140774-0-00	C-53		143293-0-01	A-33		146195-0-01	I-8 ~ 35	
140233-0-01	E-25		140774-0-01	D-30		143294-0-02	A-95		180323-0-01	C-2, 3	
140235-0-00	E-66		140775-0-01	D-56		143296-0-01	K-13		"	C-27, 28	
140236-0-01	E-68		140778-0-01	H-19		143297-0-01	D-114		181995-0-01	D-26, 27	
140237-0-01	E-63		140779-0-01	H-28		143312-0-00	B-31		403387-0-01	D-85	
140238-0-01	E-64		140780-0-01	H-6		143323-0-01	F-51		403865-0-02	G-16	
140239-0-01	E-62		"	H-7		143324-0-01	F-50		508693-0-01	H-47	
140240-0-01	E-60		"	H-20		143325-0-01	F-52				
140241-0-01	E-59		140781-0-01	H-8		143326-0-01	F-49				
140242-0-01	E-61		"	H-24		143374-0-01	A-101				
140243-0-01	E-58		140782-0-01	H-16		143375-0-01	A-54				
140244-0-01	E-50		140792-0-01	Z-23		143442-0-01	E-69				
140246-0-01	E-39		140798-0-01	Z-21		143524-0-00	B-32				
140247-0-01	E-54		140888-0-01	F-11		143531-0-01	H-10				
140260-0-01	F-28		140910-0-01	I-13		143536-0-01	A-30				
140261-0-01	F-27		140912-0-01	J-13		143537-0-00	A-29				
140262-0-00	F-31		"	K-12		143538-0-01	A-57				
140263-0-01	F-25		140913-0-01	A-19		143550-0-01	A-72				
140264-0-01	F-24		140928-0-00	D-25		143564-0-01	D-33				
140266-0-01	F-9		140989-0-01	F-1 ~ 9		143565-0-01	D-20				
"	K-3		140990-0-01	F-4		143566-0-01	Z-4				
140267-0-01	F-14		140991-0-01	F-5		143703-0-01	A-104				
140268-0-01	K-3 ~ 11		140992-0-01	F-7		143704-0-01	A-105				
140269-0-01	K-9		140993-0-01	F-8		143733-0-01	C-29				
140270-0-01	F-3		140997-0-01	E-43		143734-0-01	C-12				
"	K-8		141183-0-01	A-43		143757-0-01	G-15				
140271-0-01	K-10		141188-0-01	D-12		143758-0-01	C-18				
140272-0-01	F-6		142125-0-00	Z-12		143768-0-01	G-45				
"	K-11		142126-0-01	B-33		143774-0-01	A-80				
140273-0-01	F-1		142127-0-01	J-1		143782-0-01	A-79				
"	K-6		142182-0-01	A-64		143783-0-01	L-3				
140274-0-01	K-4		142198-0-01	J-11		143850-0-01	E-71				
140275-0-01	F-2		142201-0-01	L-1		143991-0-02	A-98				
"	K-7		142229-0-01	I-30		143992-0-01	A-99				
140276-0-01	K-5		142241-0-01	J-3		144053-0-01	D-102				
140277-0-01	F-37		142243-0-01	J-10		144055-0-01	D-103				
140278-0-01	G-40		142244-0-01	J-7		144056-0-01	D-104				
140281-0-01	G-11		142245-0-01	J-8		144079-0-01	F-44				
"	G-19		142246-0-01	J-5		144080-0-01	F-47				
"	G-22		142247-0-01	J-4		144081-0-01	F-48				
140286-0-01	G-42		142249-0-01	J-14		144082-0-01	F-43				
140289-0-01	G-10		142250-0-01	J-3 ~ 10		144083-0-01	F-54				
140290-0-01	G-56		142251-0-01	J-9		144084-0-01	F-42				
140291-0-01	G-53		142260-0-01	D-96		144085-0-01	F-46				
140292-0-01	G-51		142281-0-01	I-16		144086-0-01	F-45				
140293-0-01	G-48		142282-0-01	I-11		144088-0-01	F-55				
140294-0-01	G-50		142284-0-01	I-19		144103-0-01	G-72, 76				
140295-0-01	G-46		142292-0-01	I-17		144104-0-01	G-71, 75				
140296-0-01	A-50		142314-0-01	A-73		144105-0-01	G-70, 74				
140298-0-01	G-17		142316-0-01	I-23		144106-0-01	G-69, 73				
140299-0-01	G-55		142318-0-00	I-18		144108-0-01	G-79				
140300-0-01	B-42		142321-0-01	I-22		144109-0-01	G-78				
140305-0-01	H-58		142323-0-01	I-32		144110-0-01	G-77				
140313-0-01	E-3		"	J-20		144112-0-01	G-67, 68				
140314-0-01	H-14		"	K-18		144117-0-00	E-73				
140317-0-00	E-27		142329-0-00	I-14		144140-0-00	I-35				
140320-0-00	B-10		142330-0-01	I-28		144178-0-01	E-72				
140325-0-00	H-4		142334-0-01	Z-30		144183-0-01	I-33				
140326-0-01	B-6		142340-0-01	A-79		144184-0-01	K-19				
"	B-23		142343-0-01	Z-15		144185-0-01	J-21				
"	I-10		142370-0-01	J-15		144186-0-00	I-34				
140327-0-01	B-18		142371-0-01	J-16		"	J-22				
"	C-4		142412-0-00	I-8		"	K-20				
"	C-40		142574-0-01	D-38		144223-0-01	Z-16				
140342-0-01	Z-2		142588-0-01	D-54		144349-0-00	K-21				
140414-0-01	C-15		142589-0-01	D-13		144617-0-01	H-49 ~ 63				
140415-0-00	B-21		142590-0-01	C-7		144618-0-00	H-57				
140416-0-00	C-42		"	C-33		144619-0-00	H-51				
140417-0-00	A-68		"	E-7		144620-0-01	H-55				
"	C-43		"	E-19		144621-0-01	H-56				
140418-0-00	B-5		"	E-30		144622-0-01	H-52				
140419-0-00	C-22		142669-0-01	G-13		144623-0-00	H-60				
140420-0-00	D-15		142673-0-00	D-93		144624-0-00	H-61				
140421-0-01	A-71		142674-0-00	D-94		144625-0-00	H-62				
140425-0-01	B-27		142787-0-01	I-24		144699-0-00	J-23				
140456-0-01	J-12		142979-0-01	Z-36		144779-0-01	G-81				
140468-0-01	H-59		143151-0-01	L-2		144884-0-01	A-100				
140708-0-00	C-11		143173-0-01	B-38		144973-0-01	F-41				
"	C-37		143174-0-01	B-37		145277-0-01	Z-93				



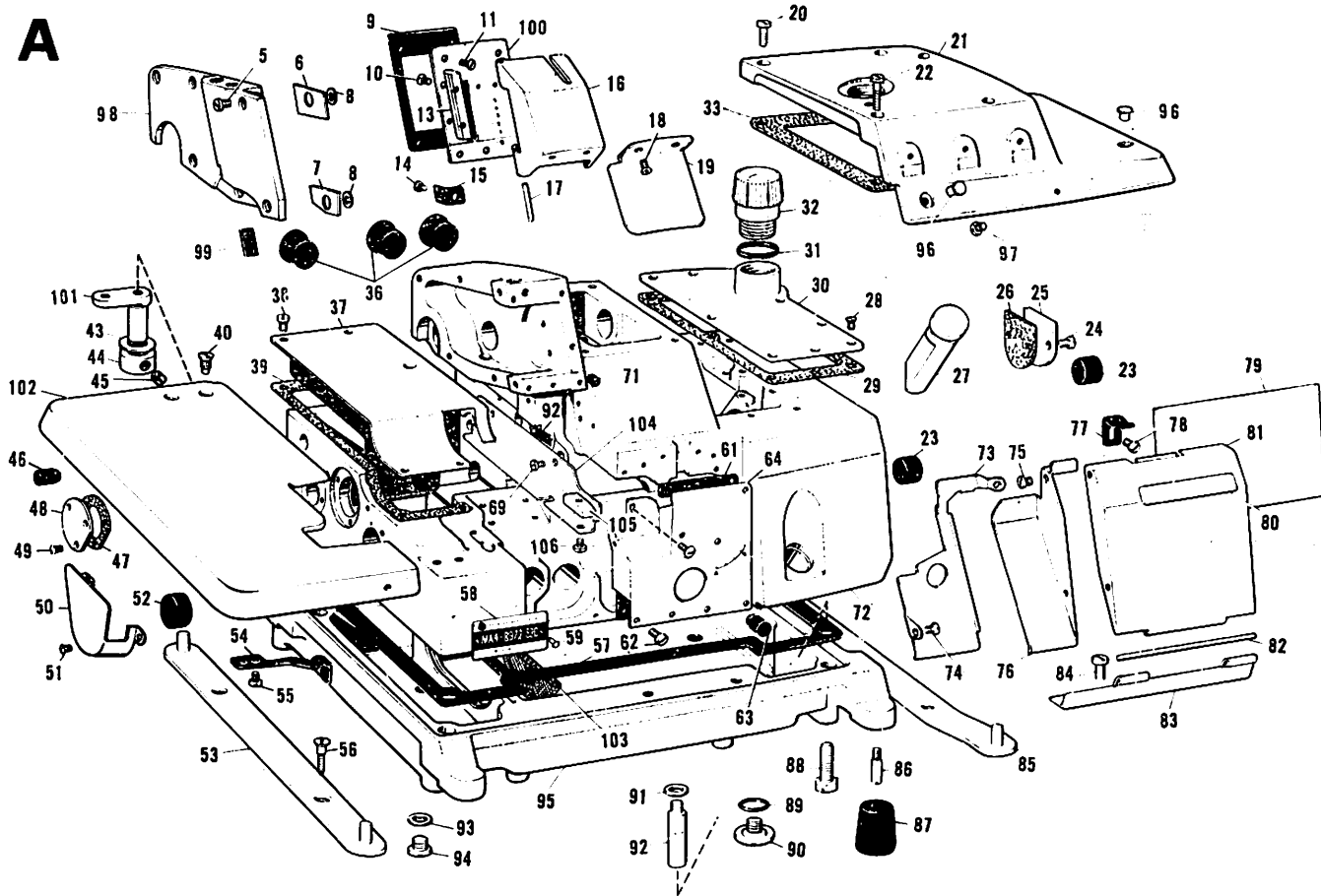

### PARTS LIST for MA4-B972-5CA

Ref. No.	Name of Parts	Qty	Parts No.	Assembly No.	Ref. No.	Name of Parts	Qty	Parts No.	Assembly No.
A-5	Set Screw for A-98	6 pcs.	100541-0-03		A-56	Set Screw 5.1 - 26	4 pcs.	100469-0-02	
A-6	Cover Packing (Upper) for A-98	1 pce.	140036-0-01		A-57	Packing for Oil Reservoir	1 pce.	143538-0-01	
A-7	Cover Packing (Lower) for A-98	1 -	140152-0-01		A-58	Model Plate (B972-5CA)	1 -	143284-0-01	
A-8	Washer for A-98	2 pcs.	110735-0-01		A-59	Pin for A-58	2 pcs.	116231-0-01	
A-9	Face Plate Packing	1 pce.	140043-0-01		A-61	Packing for A-64	1 pce.	140083-0-01	
A-10	Flat Head Screw for A-11	2 pcs.	102843-0-04		A-62	Set Screw for A-64	5 pcs.	100185-0-04	
A-11	Flat Head Screw for A-100	5 -	102843-0-04		A-63	Oil Cap	1 pce.	104832-0-01	
A-13	Hinge for A-16	1 pce.	140039-0-01		A-64	Inside Cover	1 -	142182-0-01	
A-14	Set Screw for A-15	1 -	100242-0-02		A-68	Wick 6x6	1 -	140417-0-00	
A-15	Stopper Spring for A-16	1 -	140041-0-01	140037-0-02	A-69	Flat Head Screw for A-104	2 pcs.	100185-0-04	
A-16	Needle Thread Take-up Cover	1 -	140038-0-02		A-71	Oil Cap 6.3x10	1 pce.	140421-0-01	
A-17	Pin for A-11	2 pcs.	140040-0-01		A-72	Machine Body	1 -	143550-0-01	
A-18	Set Screw for A-19	2 -	100130-0-01		A-73	Looper Cover (A)	1 -	142314-0-01	
A-19	Eye Guard	1 pce.	140913-0-01		A-74	Set Screw for A-73	2 pcs.	100185-0-04	
A-20	Set Screw for A-21	2 pcs.	009681-0-14		A-75	Set Screw for A-76	2 -	100185-0-04	
A-21	Top Cover	1 pce.	143292-0-02		A-76	Looper Cover (B)	1 pce.	140058-0-01	
A-22	Set Screw for A-21	2 pcs.	009682-0-14		A-77	Stopper Spring for A-81	1 -	140057-0-01	
A-23	Oil Cap 14.3x10	2 -	140065-0-01		A-78	Set Screw for A-77	1 -	100185-0-04	
A-24	Set Screw for A-25	2 -	100185-0-03		A-79	Threading Diagram for Five Threads	1 -	143782-0-01	
A-25	Cover for Needle Shaft Bushing (Right)	1 pce.	140109-0-01		A-80	Name Plate	1 -	143774-0-01	
A-26	Packing for A-25	1 -	140110-0-00		A-81	Front Cover	1 -	140054-0-02	
A-27	Oil Gauge	1 -	140064-0-01		A-82	Pin for A-83	1 -	140056-0-01	
A-28	Flat Head Screw for A-30	9 pcs.	107272-0-02		A-83	Hinge for Front Cover	1 -	140055-0-01	
A-29	Packing for Dust Cover (Right)	1 pce.	143537-0-00		A-84	Set Screw for A-83	2 pcs.	100644-0-03	
A-30	Dust Cover (Right)	1 -	143536-0-01		A-85	Cushion Base (Right)	1 pce.	140072-0-01	
A-31	Packing for A-32	1 -	140033-0-01		A-86	Set Pin for Cushion	4 pcs.	140077-0-01	
A-32	Cap for Oil Feeding Hole	1 -	140032-0-01		A-87	Cushion	4 -	140071-0-01	
A-33	Packing for A-21	1 -	143283-0-01		A-88	Hexagonal Bolt SM 7.91 28 - 22	4 -	017822-2-13	
A-36	Oil Cap	3 pcs.	104449-0-01		A-89	Rubber Packing for A-90	1 pce.	109203-0-01	
A-37	Cover for Feed Mechanism	1 pce.	140045-0-01		A-90	Set Screw for A-89	1 -	110641-0-01	
A-38	Set Screw for A-37	4 pcs.	100137-0-02		A-91	Washer for A-92	4 pcs.	140758-0-00	
A-39	Packing for A-37	1 pce.	140048-0-00		A-92	Machine Body Leg	4 -	140067-0-01	
A-40	Flat Head Screw for A-42	2 pcs.	100032-0-01		A-93	Packing	1 pce.	112348-0-01	
A-43	Washer for A-44	1 pce.	141183-0-00		A-94	Oil Draining Screw	1 -	112467-0-01	
A-44	Set Collar for A-101	1 -	110495-0-03		A-95	Oil Reservoir	1 -	143284-0-02	
A-45	Set Screw for A-44	2 pcs.	101706-0-01		A-96	Cap	2 pcs.	111865-0-01	
A-46	Oil Cap	1 pce.	104832-0-01		A-97	Set Screw	1 pce.	111443-0-01	
A-47	Packing for A-48	1 -	140187-0-00		A-98	Cover for Needle Driving Mechanism	1 -	143991-0-02	
A-48	Cover for Feed Shaft Bushing (Left)	1 -	140188-0-02		A-99	Cap	1 -	143992-0-01	
A-49	Flat Head Screw for A-50	3 pcs.	102538-0-06		A-100	Face Plate	1 -	144884-0-01	
A-50	Cover for G-56	1 pce.	140296-0-01		A-101	Cloth Plate Supporter	1 -	143374-0-01	140727-0-01
A-51	Set Screw for A-50	2 pcs.	100185-0-04		A-102	Cloth Plate	1 -	140060-0-01	
A-52	Oil Cap 20.3x10	1 pce.	140066-0-01		A-103	Oil Filter	1 -	145664-0-00	
A-53	Cushion Base (Left)	1 -	140075-0-01		A-104	Cloth Guide	1 -	143703-0-01	
A-54	Stopper Spring for A-42	1 -	143375-0-01		A-105	Chain Guide	1 -	143704-0-01	
A-55	Set Screw for A-54	2 pcs.	100185-0-03		A-106	Set Screw for A-105	1 -	009670-5-16	

# B

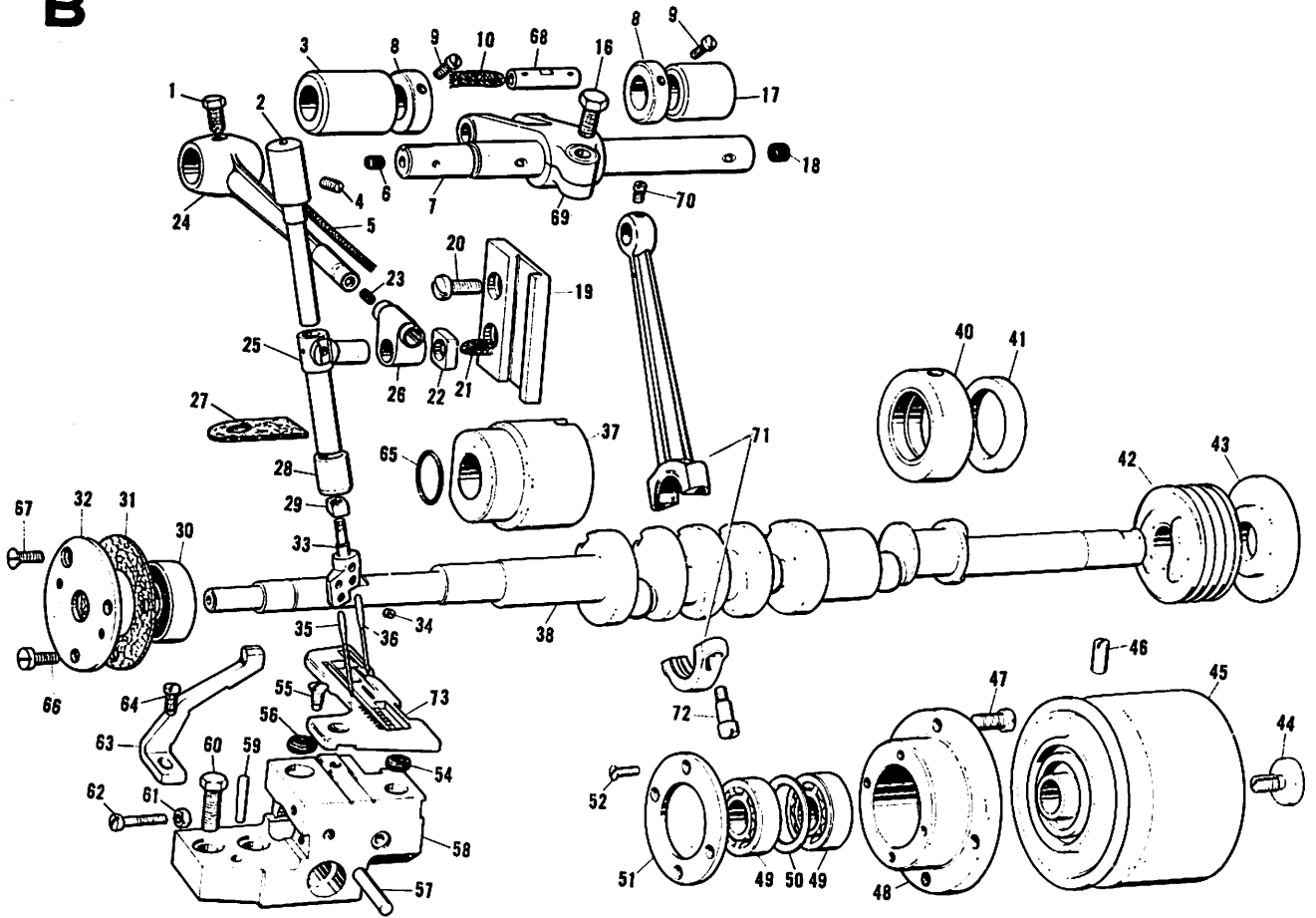

Ref. No.	Name of Parts	Q'ty	Parts No.	Assembly No.	Ref. No.	Name of Parts	Q'ty	Parts No.	Assembly No.
B-1	Set Screw for B-24	1 pce.	140095-0-01		B-40	Crank Shaft Bushing (Centre)	1 pce.	143179-0-01	
B-2	Needle Bar Bushing (Upper)	1 *	140097-0-01		B-41	Ring for B-40	1 *	143182-0-01	
B-3	Needle Shaft Bushing (Left)	1 *	140093-0-01		B-42	Worm	1 *	140300-0-01	
B-4	Set Screw for B-3	1 *	100260-0-01		B-43	Oil Rejector	1 *	140084-0-00	
B-5	Wick 6x6 (56)	1 *	140418-0-00		B-44	Cap Screw for B-45	1 *	140180-0-01	
B-6	Oil Cap 3.3φx5	1 *	140326-0-01		B-45	Pulley	1 *	140085-0-02	
B-7	Needle Shaft	1 *	140090-0-01		B-46	Set Screw for B-45	2 pcs.	100016-0-03	
B-8	Set Coller for B-7	2 pcs.	140092-0-01		B-47	Set Screw for B-48	4 *	100368-0-02	
B-9	Set Screw for B-8	4 *	100366-0-01		B-48	Bearing Case	1 pce.	110670-0-00	
B-10	Wick 6x6 (52)	1 pce.	140320-0-00		B-49	Bearing 6001	2 pcs.	110671-0-00	
B-16	Hexagonal Bolt SM6.35-40x14	1 *	017771-4-10		B-50	Thrust Washer	1 pce.	110672-0-00	
B-17	Needle Shaft Bushing (Right)	1 *	140091-0-00		B-51	Bearing Cover	1 *	110673-0-00	
B-18	Oil Cap 6.3φx5	1 *	140327-0-01		B-52	Set Screw for B-51	4 pcs.	107244-0-01	
B-19	Needle Bar Guide	1 *	105079-0-01		B-54	Cloth plate Cushion (A)	1 pce.	140106-0-01	
B-20	Set Screw for B-19	2 pcs.	100541-0-01		B-55	Set Screw for B-73	1 *	100032-0-01	
B-21	Wick 4x4 (30)	1 pce.	140415-0-00		B-56	Cloth Plate Cushion (B)	1 *	111486-0-01	
B-22	Slide Block for B-19	1 *	105078-0-01		B-57	Dowel Pin	1 *	140063-0-01	
B-23	Oil Cap 3.3φx5	1 *	140326-0-01		B-58	Needle Plate Support Bracket	1 *	140105-0-02	
B-24	Needle Arm	1 *	140094-0-01		B-59	Taper Pin 3.5x24	1 *	107351-0-01	
B-25	Needle Bar	1 *	140098-0-01		B-60	Hexagonal Bolt SM6.35-28x20	2 pcs.	017782-0-14	
B-26	Needle Bar Connector	1 *	140096-0-01		B-61	Nut for B-62	1 pce.	106129-0-01	
B-27	Felt for B-28	1 *	140425-0-01		B-62	Set Screw for B-58	1 *	101552-2-01	
B-28	Needle Bar Bushing (Lower)	1 *	140099-0-01		B-63	Overlock Stitch Needle Guard	1 *	140108-0-03	
B-29	Nut for B-33	1 *	140100-0-01		B-64	Set Screw for B-63	1 *	100137-0-02	
B-30	Bearing 6000D	1 *	072600-0-30		B-65	Packing	1 *	114294-0-01	
B-31	Packing for B-32	1 *	143312-0-00		B-66	Set Screw for B-32	2 pcs.	100264-0-04	
B-32	Bearing Plate	1 *	143524-0-00		B-67	Set Screw for B-32	1 pce.	117127-0-02	
B-33	Needle Clamp (5mm)	1 *	142126-0-01		B-68	Pin for B-69	1 *	140088-0-01	
B-34	Needle Set Screw for B-33	2 pcs.	117666-0-01		B-69	Needle Arm Driving Lever	1 *	140089-0-01	
B-35	Needle DM x 13	1 pce.	140104-0-16		B-70	Set Screw for B-71	1 *	100366-0-01	145638-0-01
B-36	Needle DC x 1	1 *	112297-0-16		B-71	Needle Arm Driving Crank	1 *	145640-0-01	
B-37	Crank Shaft Bushing (Left)	1 *	143174-0-01		B-72	Set Screw for B-71	2 pcs.	110686-0-01	
B-38	Crank Shaft	1 *	143173-0-01		B-73	Needle plate	1 pce.	145651-0-01	
B-39	Set Screw for B-41	1 *	110668-0-01						

C

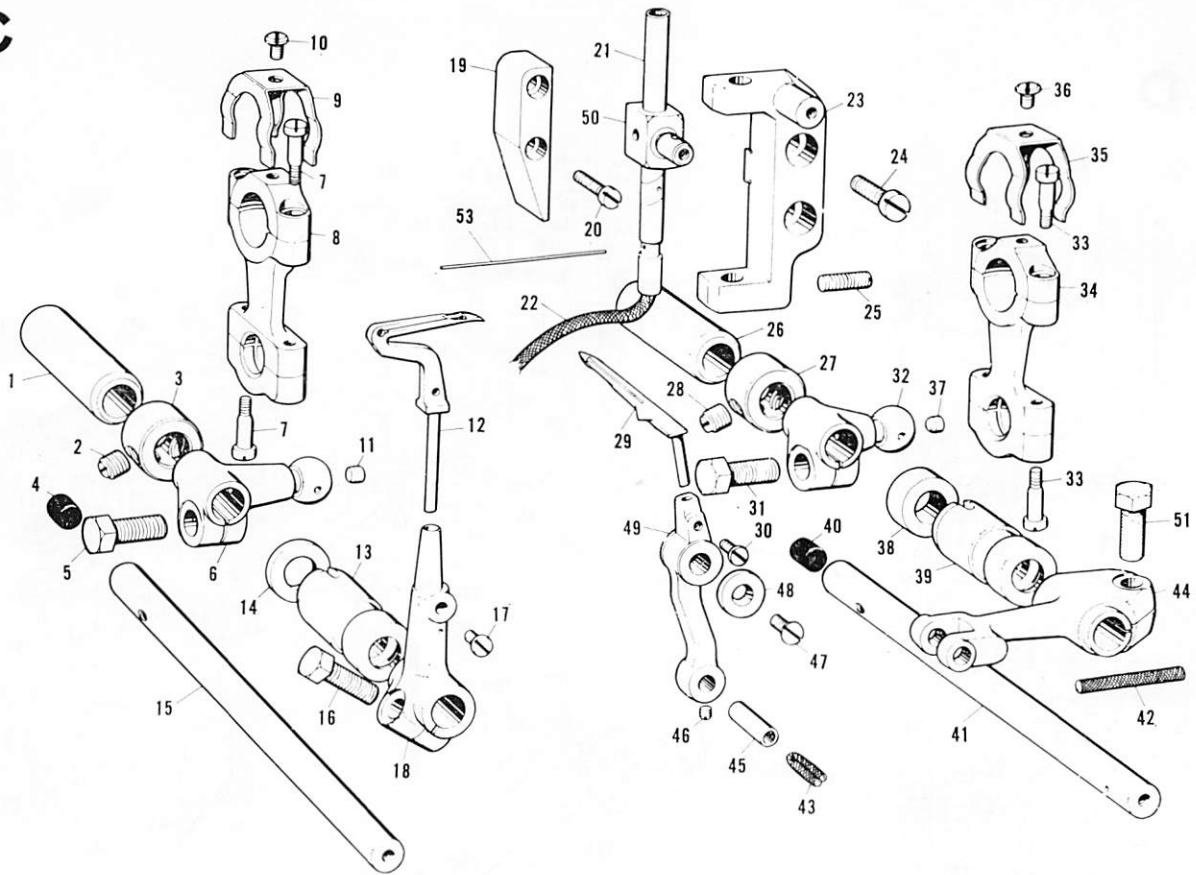

Ref. No.	Name of Parts	Qty	Parts No.	Assembly No.	Ref. No.	Name of Parts	Qty	Parts No.	Assembly No.
C-1	Connecting Rod Bushing (Rear)	1 pce.	140116-0-00		C-27	Set Collar for C-26	1 pce.	116778-0-01	
C-2	Set Screw for C-3	2 pcs.	100289-0-01	180323-0-01	C-28	Set Screw for C-27	2 pcs.	100289-0-03	180323-0-01
C-3	Set Collar	1 pce.	116778-0-01		C-29	Over Looper	1 pce.	143733-0-01	
C-4	Oil Cap 6.3φ×5	1 "	140327-0-01		C-30	Set Screw for C-29	1 "	111443-0-01	
C-5	Hexagonal Bolt SM 6.35-40×14	1 "	017771-4-12		C-31	Hexagonal Bolt SM 6.35-40×14	1 "	017771-4-12	
C-6	Under Looper Supporter	1 "	140130-0-01		C-32	Over Looper Supporter	1 "	140113-0-01	
C-7	Set Screw for C-8	4 pcs.	142590-0-01	140129-0-01	C-33	Set Screw for C-34	4 pcs.	142590-0-01	140111-0-01
C-8	Looper Connecting Rod	1 pce.	140112-0-00		C-34	Looper Connecting Rod	1 "	140112-0-00	
C-9	Looper Connecting Rod Stopper	1 "	110704-0-01		C-35	Looper Connecting Rod Stopper	1 "	110704-0-01	
C-10	Set Screw for C-9	1 "	105034-0-02		C-36	Set Screw for C-35	1 "	105034-0-02	
C-11	Oil Cap 3.5φ×3	1 "	140708-0-00		C-37	Oil Cap 3.5φ×3	1 "	140708-0-00	
C-12	Under Looper	1 "	143734-0-01		C-38	Thrust Collar for C-41	1 "	140117-0-01	
C-13	Connecting Rod Bushing (Front)	1 "	140118-0-00		C-39	Connecting Rod Bushing (Front)	1 "	140118-0-00	
C-14	Thrust Collar for C-15	1 "	110706-0-01		C-40	Coil Cap 6.3φ×5	1 "	140327-0-01	
C-15	Shaft for C-6	1 "	140414-0-01		C-41	Shaft for C-32	1 "	140115-0-01	
C-16	Hexagonal Bolt SM 5.56-32×14	1 "	017751-4-13		C-42	Wick 6×6 (27)	1 "	140416-0-00	
C-17	Set Screw for C-12	1 "	111443-0-01		C-43	Wick 6×6 (32)	1 "	140417-0-00	
C-18	Under Looper Holder	1 "	143758-0-01		C-44	Over Looper Driving Lever	1 "	140119-0-01	
C-19	Guide for C-22	1 "	140114-0-00		C-45	Pin for C-49	1 "	140120-0-01	
C-20	Set Screw for C-19	2 pcs.	105827-0-01		C-46	Set Screw for C-45	1 "	104651-0-01	
C-21	Over Looper Holder Guide Shaft	1 pce.	140124-0-01		C-47	Flat Head Screw SM 3.57-40×6	1 "	003670-6-14	
C-22	Wick 6×6 (90)	1 "	140419-0-00		C-48	Washer for C-49	1 "	140127-0-01	140128-0-01
C-23	Supporting Block for C-21	1 "	140125-0-01		C-49	Over Looper Holder	1 "	140121-0-01	
C-24	Set Screw SM 4.76-32×10	2 pcs.	009711-0-13		C-50	Over Looper Holder Slide Block	1 "	140122-0-01	
C-25	Set Screw for C-21	1 pce.	106069-0-01		C-51	Hexagonal Bolt SM 6.35-40×14	1 "	017771-4-12	
C-26	Connecting Rod Bushing (Rear)	1 "	140116-0-00		C-53	Long Pin 0.32×70	2 pcs.	140774-0-00	

# D

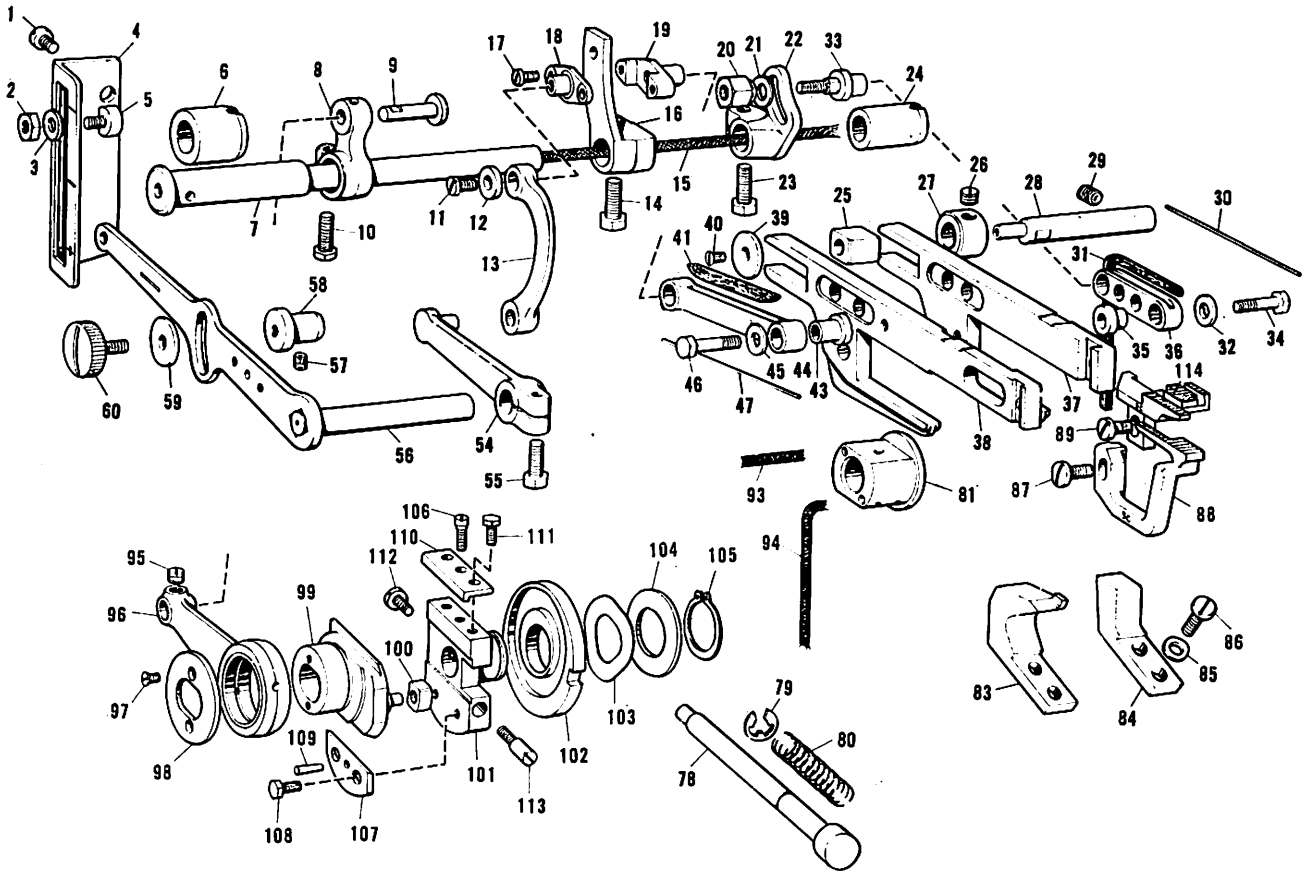

Ref. No.	Name of Parts	Q'ty	Parts No.	Assembly No.	Ref. No.	Name of Parts	Q'ty	Parts No.	Assembly No.
D-1	Set Screw for D-4	2 pcs.	100541-0-02		D-45	Washer for D-44	1 pce.	140208-0-01	
D-2	Nut for D-5	2 "	110161-0-04		D-46	Feed Link Shaft (Large)	1 "	140217-0-01	
D-3	Washer for D-2	2 "	113431-0-02		D-54	Differential Feed Link Lever	1 "	142588-0-01	
D-4	Differential Stitch Control	1 pce.	140228-0-01		D-55	Hexagonal Bolt SM 6.35-40×14	1 "	117771-4-12	
D-5	Stopper Screw for D-4	2 pcs.	140229-0-01		D-56	Differential Adjusting Lever	1 "	140775-0-01	
D-6	Feed Shaft Bushing (Left)	1 pce.	140185-0-00		D-57	Set Screw for D-58	1 "	100539-0-03	
D-7	Feed Shaft	1 "	140184-0-01		D-58	Bushing for D-56	1 "	140226-0-01	
D-8	Feed Arm	1 "	140179-0-01		D-59	Washer D-60	1 "	116662-0-01	
D-9	Pin for D-8	1 "	140178-0-01		D-60	Set Screw for D-56	1 "	143287-0-01	
D-10	Hexagonal BM 6.35-40×14	1 "	017771-4-12		D-78	Feed Adjusting Shaft	1 "	140182-0-01	
D-11	Set Screw for D-13	1 "	003670-6-14		D-79	Stop Ring	1 "	109574-0-01	
D-12	Washer for D-13	1 "	141188-0-01		D-80	Feed Adjusting Spring	1 "	140183-0-01	
D-13	Differential Feed Adjusting Ring	1 "	142589-0-01		D-81	Feed Lifting Slide Block	1 "	140196-0-00	
D-14	Hexagonal Bolt SM 6.35-40×12	1 "	017771-2-12		D-83	Feed Bar Guide (Left)	1 "	142574-0-01	
D-15	Wick 6×6 (135)	1 "	140420-0-01		D-84	Feed Bar Guide (Right)	1 "	140197-0-01	
D-16	Differential Feed Arm	1 "	140212-0-01		D-85	Washer for D-86	4 pcs.	403387-0-01	
D-17	Set Screw for D-18	2 pcs.	109836-0-01		D-86	Set Screw for D-84	4 "	107407-0-02	
D-18	Cap for D-19	1 pce.	140214-0-01	140211-0-01	D-87	Set Screw for D-88	1 pce.	009681-2-12	
D-19	Differential Feed Adjuster	1 "	140213-0-01		D-88	Differential Feed Dog	1 "	140194-0-01	
D-20	Nut for D-33	1 "	143565-0-01		D-89	Set Screw for D-90	1 "	140193-0-01	
D-21	Washer for D-20	1 "	100579-0-02		D-93	Wick 3×3 (20)	1 "	142673-0-00	
D-22	Main Feed Arm	1 "	140205-0-01		D-94	Wick 3×3 (130)	1 "	142674-0-00	
D-23	Hexagonal SM 6.35-40×12	1 "	017771-2-12		D-95	Set Screw for D-96	1 "	100251-0-01	
D-24	Feed Shaft Bushing (Right)	1 "	140186-0-00		D-96	Feed Rod	1 "	142260-0-01	
D-25	Feed Bar Guide Block	1 "	140928-0-00		D-97	Set Screw for D-98	2 pcs.	111104-0-01	
D-26	Set Screw for D-27	2 pcs.	101706-0-01	181995-0-01	D-98	Feed Rod Presser Plate	1 pce.	140176-0-01	
D-27	Set Collar for D-28	1 pce.	104521-0-01		D-99	Eccentric Wheel	1 "	145286-0-01	
D-28	Feed Bar Guide Block Shaft	1 "	140202-0-01		D-100	Slide Block for D-101	1 "	140165-0-01	
D-29	Set Screw for D-28	1 "	105163-0-01		D-101	Eccentric Wheel Holder	1 "	145285-0-01	
D-30	Steel Wire 0.32×100	1 "	140774-0-01		D-102	Eccentric Wheel Adjusting Cam	1 "	144053-0-01	
D-31	Felt for D-36	1 "	140771-0-01		D-103	Ripple Spring	1 "	144055-0-01	
D-32	Washer for D-33	1 "	140208-0-01		D-104	Spring Presser Ring	1 "	144056-0-01	
D-33	Main Feed Link Shaft (Large)	1 "	143564-0-01		D-105	Stop Ring	1 "	048150-1-43	145284-0-01
D-34	Main Feed Link Shaft (Small)	1 "	140210-0-01		D-106	Set Screw for D-101	2 pcs.	100025-0-01	
D-35	Main Feed Link Bushing	1 "	140207-0-01		D-107	Eccentric Wheel Holder Plate (A)	1 pce.	145288-0-01	
D-36	Main Feed Link	1 "	140209-0-01		D-108	Set Screw for D-107	2 pcs.	107093-0-02	
D-37	Main Feed Bar	1 "	140190-0-01	140189-0-01	D-109	Pin for D-107	1 pce.	100215-0-00	
D-38	Differential Feed Bar	1 "	140191-0-01		D-110	Eccentric Wheel Holder Plate (B)	1 "	145289-0-01	
D-39	Slide Plate for D-25	1 "	140203-0-01		D-111	Set Screw for D-110	2 pcs.	145290-0-01	
D-40	Round Head Screw SM 3.18-40×7	1 "	005660-7-13		D-112	Stop Screw for D-99	1 pce.	107093-0-02	
D-41	Felt for D-44	1 "	140772-0-01		D-113	Adjusting Screw	1 "	145663-0-01	
D-43	Differential Feed Link Bushing	1 "	140216-0-01		D-114	Main Feed Dog (3B)	1 "	143297-0-01	
D-44	Differential Feed Link	1 "	140215-0-01						

# E

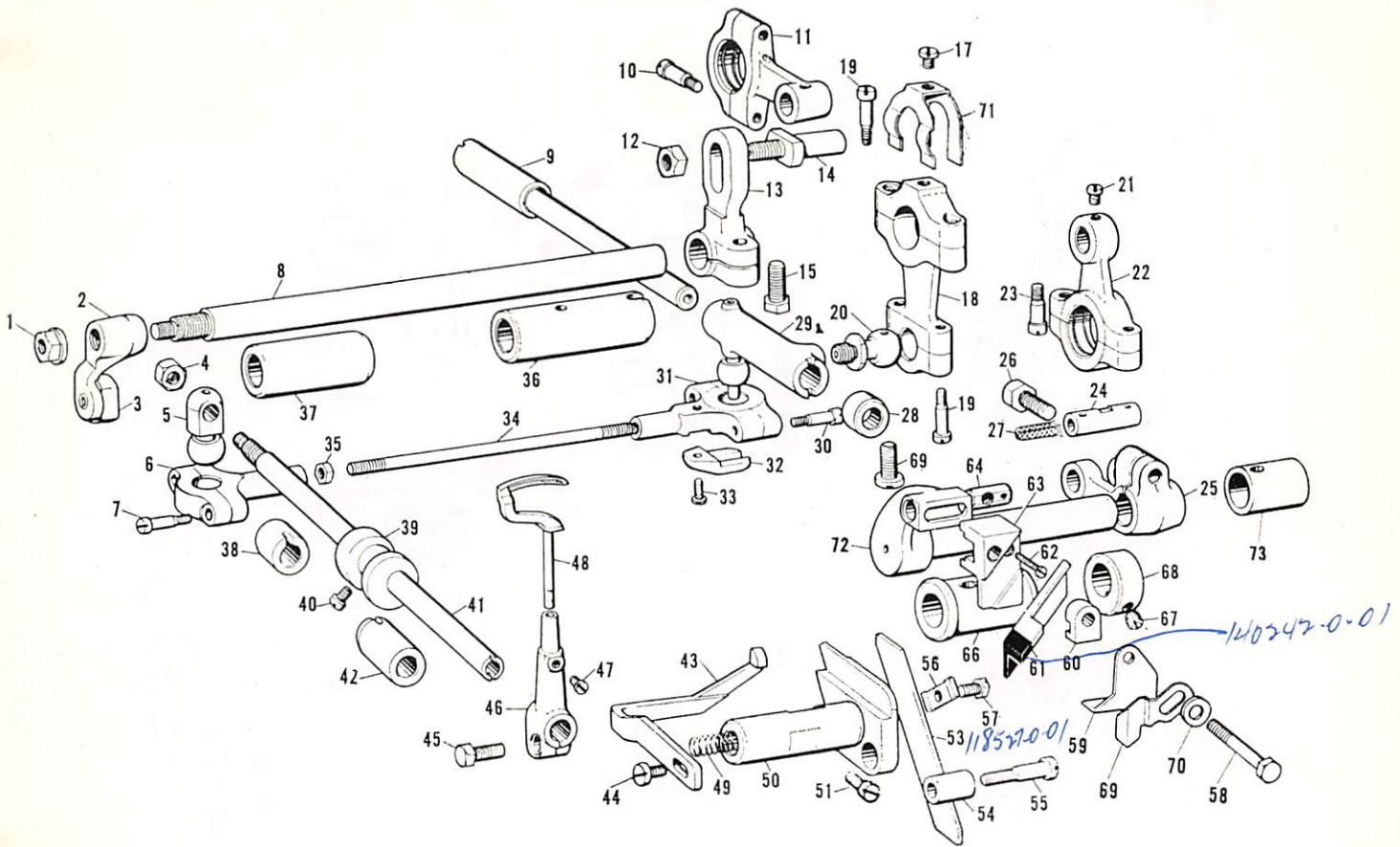

Ref. No.	Name of Parts	Q'ty	Parts No.	Assembly No.	Ref. No.	Name of Parts	Q'ty	Parts No.	Assembly No.
E-1	Nut for E-2	1 pce.	110778-0-01		E-36	Bushing (Right) for E-8	1 pce.	140150-0-00	
E-2	Longitudinal Feed Lever	1 "	140153-0-01		E-37	Bushing (Left) for E-8	1 "	140151-0-00	
E-3	Slide Block for E-2	1 "	140313-0-01		E-38	Bushing (Rear) for E-41	1 "	140158-0-00	
E-4	Nut for E-5	1 "	100176-0-01		E-39	Longitudinal Feed Cam	1 "	140156-0-01	
E-5	Connecting Lever (Left)	1 "	140142-0-01		E-40	Set Screw for E-39	2 pcs.	104908-0-01	
E-6	Connecting Lever Rod (Left)	1 "	140143-0-00	140141-0-01	E-41	Longitudinal Feed Shaft	1 pce.	140157-0-01	
E-7	Set Screw for E-6	2 pcs.	142590-0-01		E-42	Bushing (Front) for E-41	1 "	140159-0-00	
E-8	Longitudinal Feed Lever Shaft for Chain Stitch	1 pce.	140149-0-01		E-43	Chain Stitch Needle Guard	1 "	140997-0-01	
E-9	Connecting Lever Shaft	1 "	140138-0-01		E-44	Set Screw for E-43	1 "	100541-0-02	
E-10	Set Screw for E-11	2 pcs.	110686-0-01		E-45	Hexagonal Bolt SM 5.56.32×14	1 "	017751-4-13	
E-11	Longitudinal Feed Driving Rod for Chain Stitch Looper	1 pce.	140145-0-00		E-46	Chain Stitch Looper Holder	1 "	140160-0-01	
E-12	Hexagonal Nut SM 6.35-40×12	1 "	021770-1-03		E-47	Set Screw for E-48	1 "	111443-0-01	
E-13	Driving Lever for E-6	1 "	140148-0-01		E-48	Chain Stich Looper	1 "	140161-0-01	
E-14	Pin for E-11	1 "	140146-0-01		E-49	Lower Knife Holder Spring	1 "	140246-0-01	
E-15	Hexagonal Bolt SM 6.35-40×12	1 "	017771-4-12		E-50	Lower Knife Holder	1 "	140244-0-01	
E-17	Set Screw for E-71	1 "	105034-0-02		E-51	Set Screw for E-50	1 "	120823-0-01	
E-18	Looper Connecting Rod	1 "	140112-0-00		E-53	Lower Knife	1 "	118527-0-01	
E-19	Set Screw for E-18	4 pcs.	142590-0-01	140133-0-01	E-54	Lower Knife Holder Guide	1 "	140247-0-01	
E-20	Ball Joint for E-18	1 pce.	140134-0-01		E-55	Set Screw for E-54	1 "	104215-0-01	
E-21	Set Screw for E-22	1 "	100366-0-01		E-56	Lower Knife Holding Plate	1 "	117515-0-01	
E-22	Upper Knife Driving Rod	1 "	140231-0-00		E-57	Set Screw for E-56	1 "	117516-0-01	
E-23	Set Screw for E-22	2 pcs.	110686-0-01	140230-0-00	E-58	Set Screw for E-63	1 "	140243-0-01	
E-24	Pin for E-21	1 pce.	140232-0-01		E-59	Upper Knife Clamp (B)	1 "	140241-0-01	
E-25	Upper Knife Driving Lever	1 "	140233-0-01		E-60	Upper Knife Fastener	1 "	140240-0-01	
E-26	Hexagonal Bolt SM 6.35-40×14	1 "	017771-4-12		E-61	Upper Knife (B)	1 "	140242-0-01	
E-27	Wick 6×6 (44)	1 "	403717-0-00		E-62	Set Screw for E-63	1 "	140239-0-01	
E-28	Thrust Collar	1 "	140139-0-01		E-63	Upper Knife Holding Block	1 "	140237-0-01	
E-29	Connecting Lever (Right)	1 "	140136-0-01		E-64	Nut for E-63	1 "	140238-0-01	
E-30	Set Screw for E-31	2 pcs.	142590-0-01	140135-0-01	E-66	Bushing for E-72	1 "	140235-0-00	
E-31	Connecting Lever Rod (Right)	1 pce.	140137-0-00		E-67	Set Screw SM 5.56.32×6	2 pcs.	013750-6-14	
E-32	Guide for E-31	1 "	110720-0-01		E-68	Set Collar for E-65	1 pce.	140236-0-01	
E-33	Set Screw for E-22	1 "	100080-0-03		E-69	Upper Knife Guard	1 "	143442-0-01	
E-34	Connecting Bar for E-31,36	1 "	140140-0-01		E-70	Washer for E-69	1 "	100645-0-03	
E-35	Hexagonal Nut SM 4.76-32	2 pcs.	022710-1-03		E-71	Looper Connecting Rod Stopper	1 "	143850-0-01	
					E-72	Upper Knife Driving Arm	1 "	144178-0-01	
					E-73	Bushing for E-72	1 "	144117-0-00	



# F

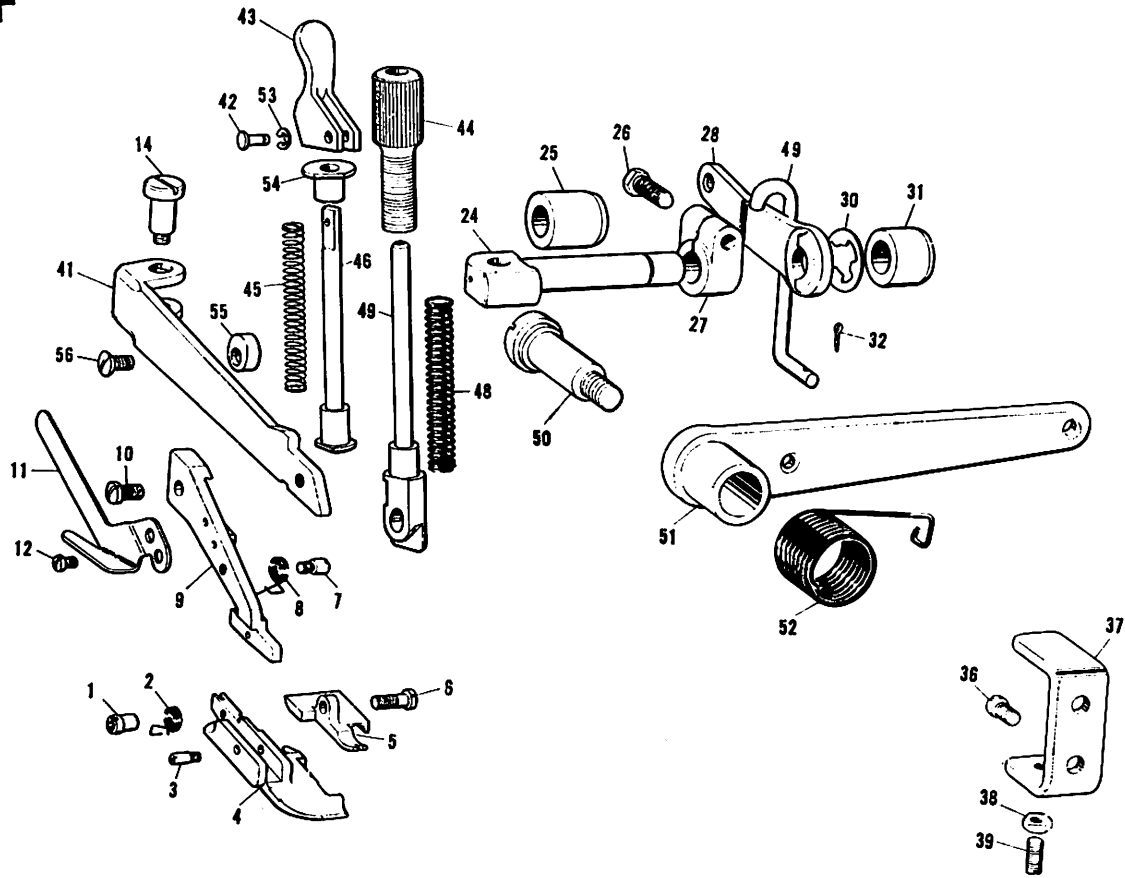

Ref. No.	Name of Parts	Q'ty	Parts No.	Assembly No.	Ref. No.	Name of Parts	Q'ty	Parts No.	Assembly No.
F-1	Screw Nut for F-6	1 pce.	140273-0-00	140989-0-01	F-36	Set Screw for F-37	2 pcs.	100541-0-02	
F-2	Spring for F-5	1 -	140275-0-01		F-37	Adjuster for F-51	1 pce.	140277-0-01	
F-3	Set Screw for F-4	1 -	140270-0-01		F-38	Nut for F-39	1 -	110161-0-03	
F-4	Presser Foot (Front)	1 -	140990-0-01		F-39	Stopper Screw for F-51	1 -	106069-0-01	
F-5	Presser Foot (Rear)	1 -	140991-0-01		F-41	Main Presser Arm	1 -	144973-0-01	
F-6	Set Screw for F-5	1 -	140272-0-01		F-42	Pin for F-43	1 -	144084-0-01	
F-7	Set Screw for F-8	1 -	140992-0-01		F-43	Presser Bar Lifter	1 -	144082-0-01	
F-8	Spring for F-4	1 -	140993-0-01		F-44	Presser Foot Adjusting Screw	1 -	144079-0-01	
F-9	Sub-presser Arm	1 -	140266-0-01		F-45	Spring for F-46	1 -	144086-0-01	
F-10	Set Screw for F-9	1 -	100541-0-03		F-46	Presser Bar Lifting Shaft	1 -	144085-0-01	
F-11	Trimming Knife	1 -	140888-0-01		F-47	Presser Bar	1 -	144080-0-01	
F-12	Set Screw for F-11	2 pcs.	100130-0-01		F-48	Presser Bar Spring	1 -	144081-0-01	
F-14	Stud Screw for F-41	1 pce.	140267-0-01		F-49	Presser Foot Lifter Ring	1 -	143326-0-01	
F-24	Presser Arm Shaft	1 -	140264-0-01		F-50	Presser Foot Lifter Lever Stud	1 -	143324-0-01	
F-25	Bushing for F-24	1 -	140263-0-00		F-51	Presser Foot Lifter Lever	1 -	143323-0-01	
F-26	Hexagonal Bolt SM 6.35-40 x 14	1 -	017771-4-12		F-52	Spring for F-51	1 -	143325-0-01	
F-27	Set Collar for F-24	1 -	140261-0-01		F-53	Stop Ring	1 -	048020-3-42	
F-28	Presser Foot Lifter Inside Lever	1 -	140260-0-01		F-54	Bushing for D-46	1 -	144083-0-01	
F-30	Stop Ring	1 -	048080-3-46		F-55	Presser Arm Stopper	1 -	144088-0-01	
F-31	Bushing (Right) for F-24	1 -	140262-0-00		F-56	Set Screw for F-55	1 -	107231-0-01	
F-32	Cotter Pin	1 -	110793-0-01						



G

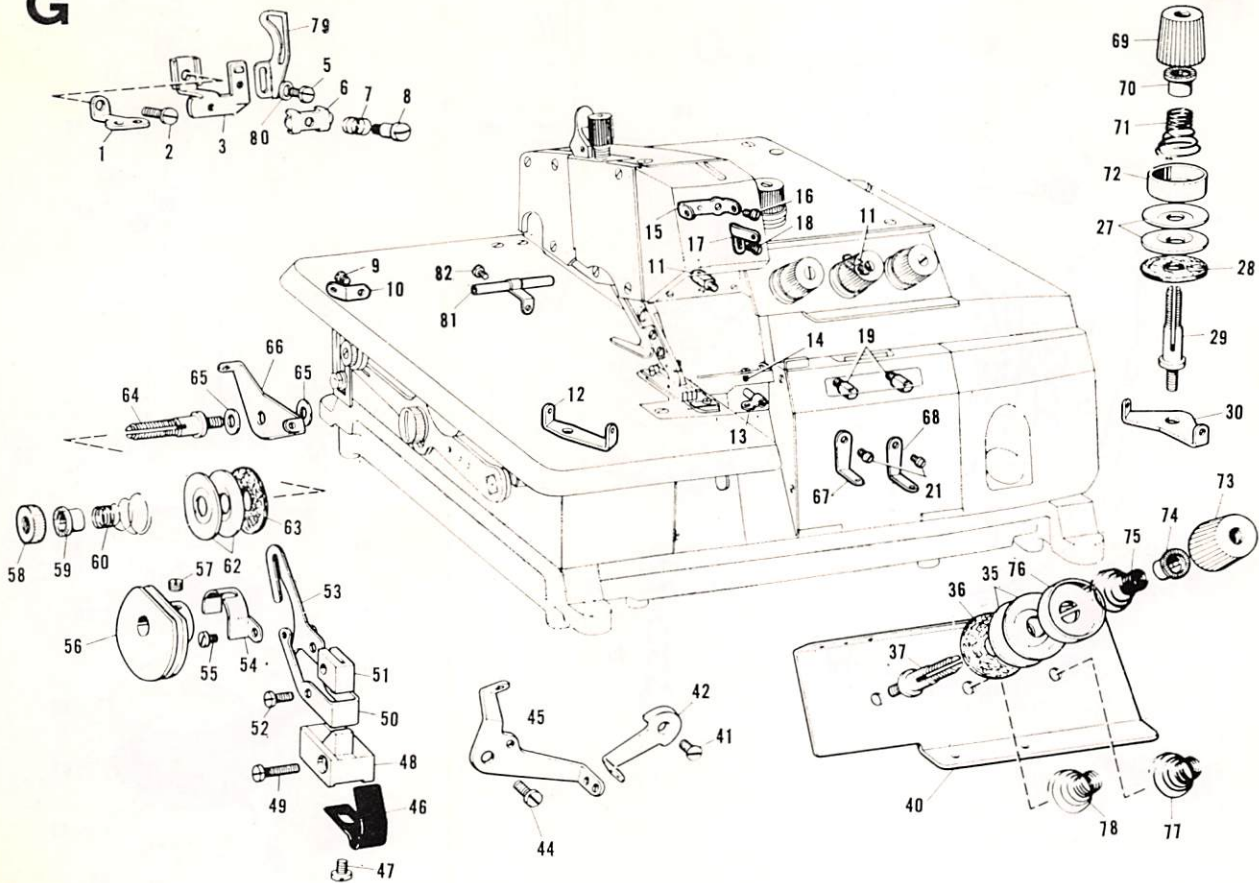

Ref. No.	Name of Parts	Qty	Parts No.	Assembly No.	Ref. No.	Name of Parts	Qty	Parts No.	Assembly No.
G-1	Needle Thread Guide (B)	1 pce.	140103-0-01		G-51	Holder for G-53	1 pce.	140292-0-01	
G-2	Set Screw for G-1, 3	1 "	100185-0-04		G-52	Set Screw for G-53	1 "	100137-0-04	
G-3	Needle Thread Take-up Supporter	1 "	140102-0-01		G-53	Thread Handler for Chain Stitch Looper	1 "	140291-0-01	
G-5	Set Screw for G-79	1 "	009669-3-13		G-54	Thread Protector	1 "	140299-0-01	
G-6	Needle Thread Guard	1 "	112300-0-01		G-55	Set Screw for G-54	2 pcs.	101275-0-04	
G-7	Needle Thread Guard Spring	1 "	112299-0-01		G-56	Chain Stitch Looper Take-up	1 pce.	140290-0-01	
G-8	Stud Screw for G-6	1 "	112301-0-01		G-57	Set Screw for G-56	2 pcs.	102716-0-03	
G-9	Set Screw for G-10	1 "	100185-0-04		G-58	Thread Tension Adjusting Nut	1 pce.	105230-0-01	
G-10	Thread Guide (A) for Chain Stitch Looper	1 "	140289-0-01		G-59	Tension Spring Washer	1 "	105228-0-01	
G-11	Looper Thread Guide	2 pcs.	140281-0-01		G-60	Chain Stitch Thread Tension Adjusting Spring	1 "	110821-0-01	
G-12	Under Looper Thread Guide (B)	1 pce.	140284-0-01		G-62	Tension Disc	2 pcs.	108721-0-01	
G-13	Over Looper Thread Guide (B)	1 "	142669-0-01		G-63	Felt for G-62	1 pce.	110832-0-01	
G-14	Set Screw for G-13	1 "	100035-0-02		G-64	Looper Thread Tension Control Stud	1 "	143286-0-01	
G-15	Needle Thread Guide (A)	1 "	143753-0-01		G-65	Packing for G-66	1 "	140756-0-01	
G-16	Set Screw for G-15	1 "	403865-0-02		G-66	Chain Stitch Thread Guide Plate	1 "	110813-0-01	
G-17	Needle Thread Guide for Chain Stitch	1 "	140298-0-01		G-67	Looper Thread Guide	1 "	144112-0-01	
G-18	Set Screw for G-17	1 "	100137-0-03		G-68	Looper Thread Guide	1 "	144112-0-01	
G-19	Looper Thread Guide	2 pcs.	140281-0-01		G-69	Thread Tension Adjusting Screw	1 "	144106-0-01	
B-21	Set Screw for G-67, 68	2 "	100185-0-04		G-70	Tension Spring Washer	1 "	144105-0-01	
G-27	Tension Disc	2 "	108721-0-01		G-71	Needle Thread Tension Adjusting Spring	1 "	144104-0-01	
G-28	Felt for G-27	1 pce.	110832-0-01		G-72	Tension Disc Washer	1 "	144103-0-01	
G-29	Needle Thread Guide Plate	1 "	110813-0-01		G-73	Thread Tension Adjusting Screw	3 pcs.	144106-0-01	
G-30	Looper Thread Tension Control Stud	1 "	110820-0-01		G-74	Tension Spring Washer	3 "	144105-0-01	
G-35	Tension Disc	6 pcs.	108721-0-01		G-75	Needle Thread Tension Adjusting Spring	1 pce.	144104-0-01	
G-36	Felt for G-35	3 "	110832-0-01		G-76	Tension Disc Washer	3 pcs.	144103-0-01	
G-37	Looper Thread Tension Control Stud	3 "	110820-0-01		G-77	Under Looper Thread Tension Adjusting Spring	1 pce.	144110-0-01	
G-40	Thread Guide Plate	1 pce.	140278-0-01		G-78	Over Looper Thread Tension Adjusting Spring	1 "	144109-0-01	
G-41	Flat Head Screw SM 3.57-40x6	1 "	003670-6-14		G-79	Needle Thread Take-up	1 "	144108-0-01	
G-42	Looper Thread Take-up (Right)	1 "	140286-0-01		G-80	Washer for G-79	1 "	105248-0-01	
G-44	Set Screw for G-45	1 "	105123-0-01		G-81	Thread Guide Tube for Chain Stitch Looper	1 "	144779-0-01	
G-45	Looper Thread Take-up (Left)	1 "	143768-0-01		G-82	Set Screw for G-81	1 "	009670-5-14	
G-46	Spring Plate for G-50	1 "	140295-0-01						
G-47	Set Screw for G-46	1 "	107491-0-02						
G-48	Bracket for G-50	1 "	140293-0-01						
G-49	Set Screw SM 3.57-40x16	1 "	009671-6-03						
G-50	Thread Guide for Chain Stitch Looper	1 "	140294-0-01						

# H

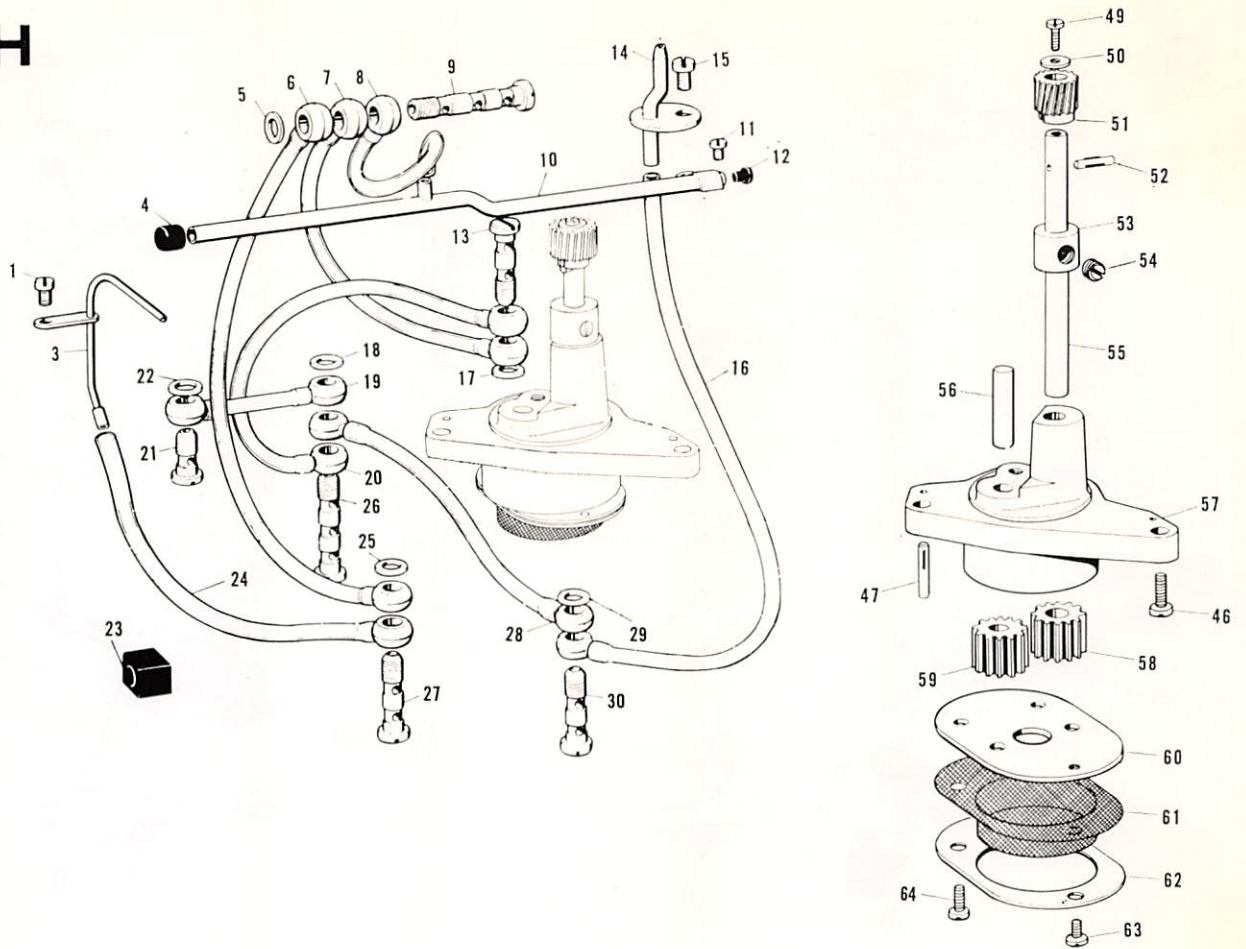

Ref. No.	Name of Parts	Qty	Parts No.	Assembly No.	Ref. No.	Name of Parts	Qty	Parts No.	Assembly No.
H-1	Set Screw for H-3	1 pce.	100185-0-03		H-26	Oil Feeding Pipe (A)	1 pce.	112351-0-01	
H-3	Oil Pipe for Feed Rod	1 "	140764-0-01		H-27	Oil Feeding Pipe (B)	1 "	112364-0-01	
H-4	Oil Cap	1 "	140325-0-01		H-28	Vinyl Tube (E) 6φ×80	1 "	140779-0-01	
H-5	Packing for H-9	1 "	112348-0-01		H-29	Packing for H-30	1 "	112348-0-01	
H-6	Vinyl Tube (A) 6φ×230	1 "	140780-0-01		H-30	Oil Feeding Pipe (B)	1 "	112364-0-01	
H-7	Vinyl Tube (A) 6φ×230	1 "	140780-0-01		H-46	Set Screw for H-34	2 pcs.	105173-0-03	
H-8	Vinyl Tube (B) 6φ×180	1 "	140781-0-01		H-47	Pin 3×16 for H-34	2 "	508693-0-01	
H-9	Oil Feeding Pipe (A)	1 "	112351-0-01		H-49	Set Screw for H-50	1 pce.	100137-0-01	
H-10	Main Oil Pipe	1 "	143534-0-01		H-50	Washer for H-49	1 "	025350-3-32	
H-11	Set Screw for H-10	2 pcs.	100185-0-03		H-51	Worm Wheel	1 "	144619-0-00	
H-12	Oil Cap	1 pce.	104833-0-01		H-52	Pin for H-49	1 "	144622-0-01	
H-13	Oil Feeding Pipe (B)	1 "	112364-0-01		H-53	Set Collar	1 "	104521-0-01	
H-14	Pilot Pipe	1 "	140314-0-01		H-54	Set Screw for H-53	2 pcs.	101706-0-01	
H-15	Set Screw for H-14	1 "	100541-0-01		H-55	Main Pump Gear Shaft	1 pce.	144620-0-01	
H-16	Vinyl Tube (C) 6φ×230	1 "	140782-0-01		H-56	Subordinate Pump Shaft	1 "	144621-0-01	144617-0-01
H-17	Packing for H-13	1 "	112348-0-01		H-57	Pump Case	1 "	144618-0-00	
H-18	Packing for H-26	1 "	112348-0-01		H-58	Main Pump Gear	1 "	140305-0-01	
H-19	Vinyl Tube (D) 6φ×50	1 "	140778-0-01		H-59	Subordinate Pump Gear	1 "	140468-0-01	
H-20	Vinyl Tube (A) 6φ×230	1 "	140780-0-01		H-60	Pump Cover	1 "	144623-0-00	
H-21	Oil Feeding Screw	1 "	112359-0-01		H-61	Oil Filter Gauze	1 "	144624-0-00	
H-22	Packing for H-21	1 "	112348-0-01		H-62	Oil Flange Filter	1 "	144625-0-00	
H-23	Tube Holder for H-24	1 "	140768-0-01		H-63	Set Screw for H-63	1 "	009689-4-12	
H-24	Vinyl Tube (B) 6φ×180	1 "	140781-0-01		H-64	Set Screw for H-60	4 pcs.	009680-8-12	
H-25	Packing for H-27	1 "	112348-0-01						



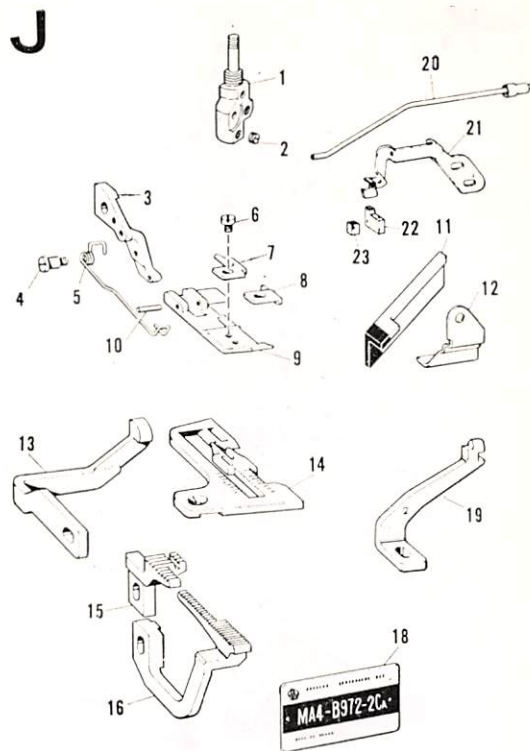
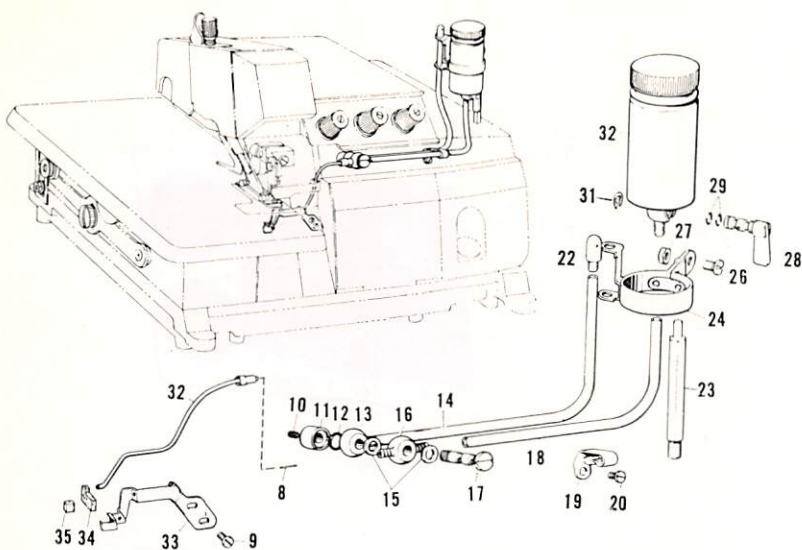

### MA4-B972-2CA

Ref. No.	Name of Parts	Q'ty	Parts No.	Assembly No.
F-8	Coler Oil Adjusting Pin	1 pce.	142412-0-00	146195-0-01
F-9	Set Screw for Felt Holder	1 "	100185-0-04	
F-10	Cap for I-11	1 "	140326-0-01	
F-11	Oil Feeding Connector Collar	1 "	142282-0-01	
F-12	Packing for I-13	1 "	104564-0-01	
F-13	Oil Feeding Connector (Single)	1 "	140910-0-01	
F-14	Vinyl Tube 6φ×180	1 "	142329-0-00	
F-15	Packing for I-16	2 pcs.	112348-0-01	
F-16	Oil Feeding Connector (Double)	1 pce.	142281-0-01	
F-17	Oil Feeding Connector	1 "	142292-0-01	
F-18	Vinyl Tube 6φ×151	1 "	142318-0-00	
F-19	Vinyl Tube Holder	1 "	142284-0-01	
F-20	Set Screw for I-19	1 "	100185-0-04	
F-22	Air Vent Receptacle	1 "	142321-0-01	
F-23	Oil Tank Holding Bolt	1 "	142316-0-01	
F-24	Oil Tank Holder	1 "	142787-0-01	
F-26	Set Screw for I-24	2 pcs.	110191-0-01	
F-27	Nut for I-26	2 "	110161-0-03	
F-28	Oil Cock	1 pce.	142330-0-01	
F-29	Packing for I-28	2 pcs.	081004-0-70	
F-30	Oil Tank	1 pce.	142229-0-01	
F-31	Stop Ring for I-28	1 "	048050-3-47	
F-32	Vinyl Tube	1 "	142323-0-01	
F-33	Felt Holder (5 mm)	1 "	144183-0-01	
F-34	Needle Cooler Felt (A)	1 "	144186-0-00	
F-35	Needle Cooler Felt (C)	1 "	144140-0-00	

This Chart shows the different parts from Model MA4-B972-5CA Other parts are same as MA4-B972-5CA				
Ref. No.	Name of Parts	Q'ty	Parts No.	Assembly No.
J-1	Needle Clamp (2mm)	1 pce.	142127-0-01	142250-0-01
J-2	Needle Set Screw for J-1	2 pcs.	117666-0-01	
J-3	Sub-Presser Arm	1 pce.	142241-0-01	
J-4	Set Screw for J-5	1 "	142247-0-01	
J-5	Spring for J-9	1 "	142246-0-01	
J-6	Set Screw for J-7, 8	1 "	114447-0-01	
J-7	Stitch Tongue	1 "	142244-0-01	
J-8	Chip Guard	1 "	142245-0-01	
J-9	Presser Foot	1 "	142251-0-01	
J-10	Set Pin for J-9	1 "	142243-0-01	
J-11	Upper Knife (A)	1 "	142198-0-01	
J-12	Upper Knife Clamp (A)	1 "	140456-0-01	
J-13	Chain Stitch Needle Guard	1 "	140912-0-01	
J-14	Needle Plate	1 "	142249-0-01	
J-15	Main Feed Dog	1 "	142370-0-01	
J-16	Differential Feed Dog	1 "	142371-0-01	
J-18	Model Plate (B972-2CA)	1 "	143280-0-01	
J-19	Overlock Needle Guard	1 "	140108-0-02	
J-20	Vinyl Tube	1 "	142323-0-01	
J-21	Felt Holder (2mm)	1 "	144185-0-01	
J-22	Needle Cooler Felt (A)	1 "	144186-0-00	
J-23	Needle Cooler Felt (D)	1 "	144699-0-00	

**K**

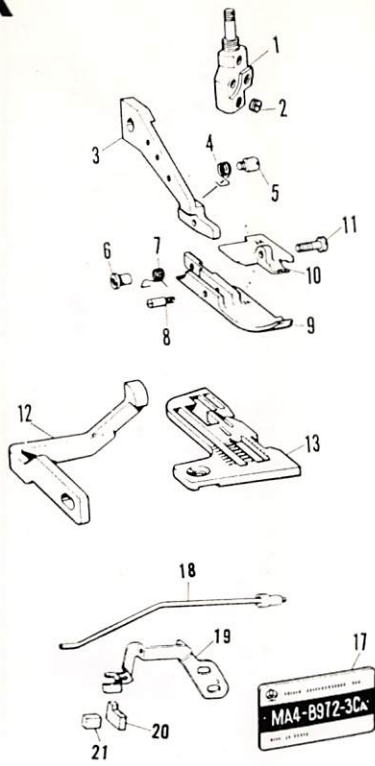

**L**

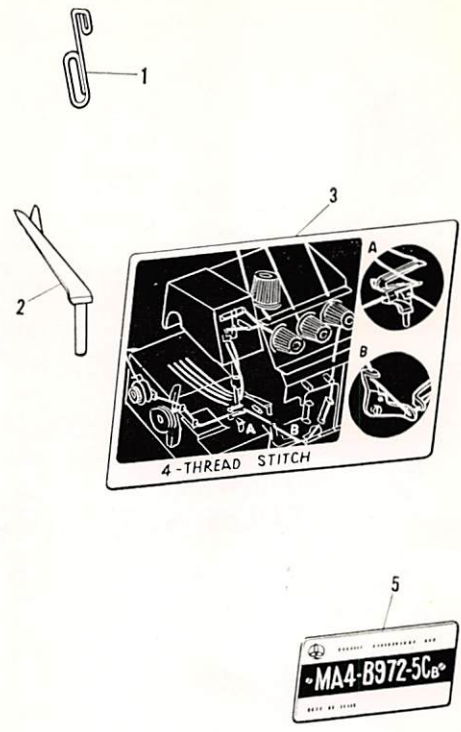

**MA4-B972-3C<sub>A</sub>**

**MA4-B972-2, 3, 5C<sub>B</sub>**

This Chart shows the different parts from Model MA4-B972-5CA Other parts are same as MA4-B972-5CA					This Chart shows the different parts from Model MA4-B972-5CA Other parts are same as MA4-B972-5CA				
Ref. No.	Name of Parts	Q'ty	Parts No.	Assembly No.	Ref. No.	Name of Parts	Q'ty	Parts No.	Assembly No.
K-1	Needle Clamp (3mm)	1 pce.	140736-0-01	140268-0-01	L-1	Needle Thread Take-up	1 pce.	142201-0-1	
K-2	Needle Set Screw for K-1	2 pcs.	117666-0-01		L-2	Over Spreader	1 "	143151-0-1	
K-3	Sub Presser Arm	1 pce.	140266-0-01		L-3	Threading Diagram	1 "	143783-0-1	
K-4	Spring for K-9	1 "	140274-0-01		L-5	Model Plate for B972-5CB	1 "	143284-0-1	
K-5	Set Screw for K-4	1 "	140276-0-01		L-5	Model Plate for B972-3CB	1 "	143282-0-1	
K-6	Screw Nut for K-11	1 "	140273-0-01		L-5	Model Plate for B972-2CB	1 "	143280-0-1	
K-7	Spring for K-10	1 "	140275-0-01						
K-8	Set Screw for K-9	1 "	140270-0-01						
K-9	Presser Foot (Front)	1 "	140269-0-01						
K-10	Presser Foot (Rear)	1 "	140271-0-01						
K-11	Set Screw for K-10	1 "	140272-0-01						
K-12	Chain Stitch Needle Guard (3mm)	1 "	140912-0-01						
K-13	Needle Plate	1 "	143296-0-01						
K-17	Model Plate (B972-3CA)	1 "	143282-0-01						
K-18	Vinyl Tube	1 "	144223-0-01						
K-19	Felt Holder (3mm)	1 "	144184-0-01						
K-20	Needle Cooler Felt (A)	1 "	144186-0-00						
K-21	Needle Cooler Felt (B)	1 "	144349-0-00						



# Z

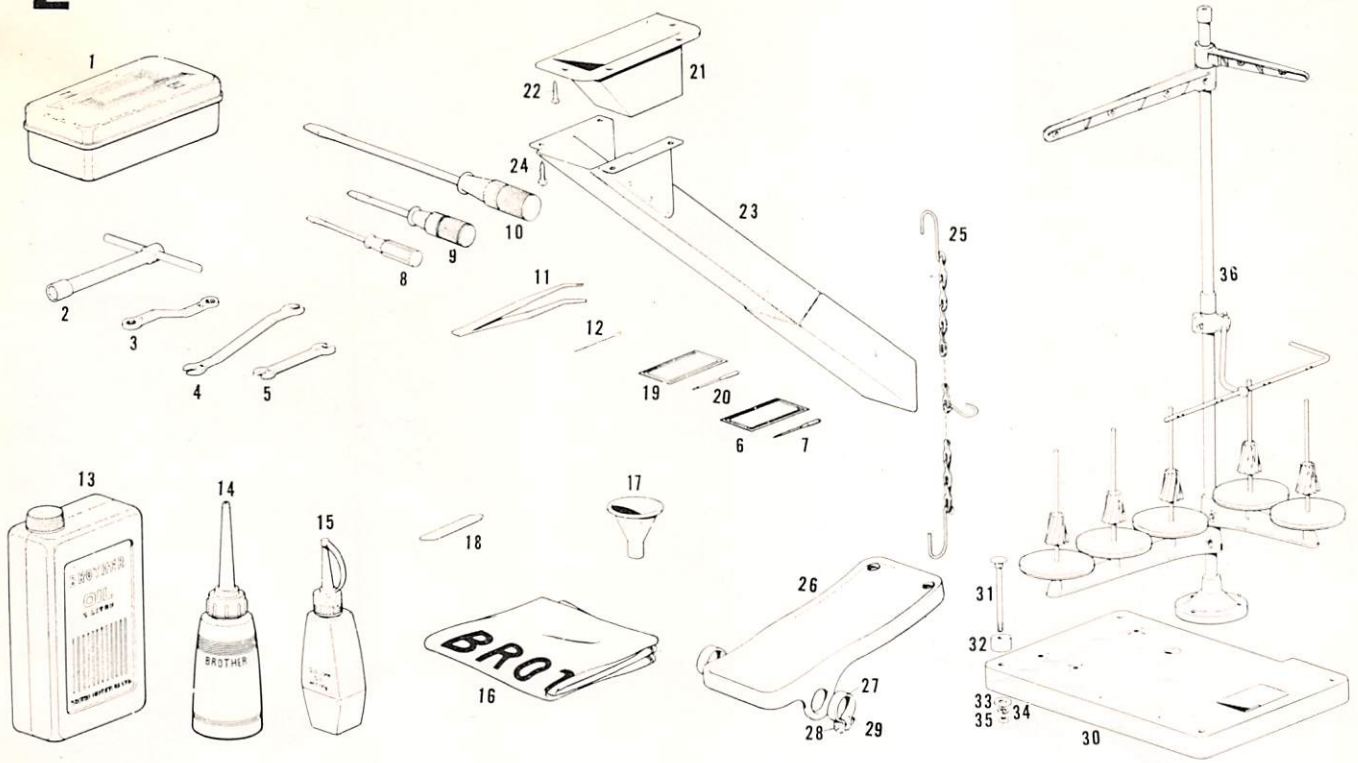

Ref. No.	Name of Parts	Qty	Parts No.	Assembly No.	Ref. No.	Name of Parts	Qty	Parts No.	Assembly No.
● Z-1	Accessory Box	1 pce.	110436-0-01		● Z-19	Needle Bag	1 pce.	108962-0-01	
Z-2	Box Wrench	1 "	140342-0-01		● Z-20	Needle DC×1	10 pcs.	112297-	
● Z-3	Spanner 8×9	1 "	105343-0-01		Z-21	Duster Drop	1 pce.	140798-0-01	
● Z-4	Wrench 8×8	1 "	143566-0-01		Z-22	Set Screw for Z-21	4 pcs.	101795-0-01	
● Z-5	Wrench 6×7	1 "	107779-0-01		Z-23	Duster shoot	1 pce.	140792-0-01	
● Z-6	Needle Bag	1 "	108962-0-01		Z-24	Set screw for Z-23	4 pcs.	031451-6-03	
● Z-7	Needle DM×13	10 pcs.	140104-		Z-25	Chain (B)	1 pce.	106812-0-01	
● Z-8	Screwdriver 2.6×70	1 pce.	105344-0-01		Z-26	Foot Pedal	1 "	117437-0-01	
● Z-9	Screwdriver 5.5×75	1 "	102629-0-04		Z-27	Foot Pedal Stopper	2 pcs.	116016-0-01	
Z-10	Screwdriver 5.5×200	1 "	101572-0-01		Z-28	Set Screw	2 "	001401-4-06	
● Z-11	Tweezer	1 "	117466-0-00		Z-29	Nut	2 "	021400-1-06	
● Z-12	Thread Guide	3 pcs.	142125-0-00		Z-30	Wooden Plate for Machine head	1 pce.	142334-0-01	
Z-13	Oil	1 pce.	145277-0-01		Z-31	Bolt	4 pcs.	140738-0-01	
Z-14	Oiler	1 "	114483-0-01		Z-32	Collar	4 "	140739-0-01	
Z-15	Needle Cooler Oil	1 "	142343-0-01		Z-33	Washer	4 "	025080-3-36	
Z-16	Head Cover	1 "	144225-0-01		Z-34	Spring Washer	4 "	028080-2-43	
Z-17	Funnel	1 "	140759-0-00		Z-35	Nut	4 "	021080-1-06	
● Z-18	Lower Knife	1 "	118527-0-01		Z-36	Cotton Stand (No.5TH)	1 pce.	142979-0-01	

### Remarks:

※The parts with mark (●) are in accessory box.

※The following parts are enclosed in the accessory box for our packing convenience.

Ref. No. A-18, A-19, A-53, A-56, A-85, A-87

