

MA4-8972



Please clarify Ref. No. and  
Parts No. as well as parts name  
When you place an order.

972

I 007094

## I N D E X

Parts. No.	Ref. No.	Remark	Parts. No.	Ref. No.	Remark	Parts. No.	Ref. No.	Remark	Parts. No.	Ref. No.	Remark
003670-6-14	C-47		100137-0-02	B-64		101552-0-01	B-62		109574-0-01	D-79	
"	D-11		100137-0-03	G-18		101706-0-01	A-45		109814-0-01	G-26	
"	G-41		100176-0-01	E-4		"	D-26		"	G-34	
005660-7-13	D-40		100185-0-03	A-24		102538-0-06	A-49		109836-0-01	D-17	
009669-3-13	G-5		"	A-55		102716-0-03	G-57		110161-0-03	F-38	
009671-6-03	G-49		"	H-1		102843-0-01	F-17		"	I-27	
009681-0-14	A-20		"	H-11		102843-0-04	A-10		110161-0-04	D-2	
009681-2-12	D-87		"	H-44		"	A-11		110191-0-01	I-26	
009682-0-11	A-3		100185-0-04	A-51		104215-0-01	E-55		110495-0-01	A-44	
009682-0-14	A-22		"	A-62		104449-0-01	A-36		110641-0-01	A-90	
009711-0-13	C-24		"	A-69		104521-0-01	D-27		110671-0-00	B-49	
013750-6-14	E-67		"	A-74		104564-0-01	I-12		110668-0-01	B-39	
017751-4-13	C-16		"	A-75		104651-0-01	C-46		110670-0-00	B-48	
"	E-45		"	A-78		104767-0-02	D-68		110672-0-00	B-50	
017771-4-12	D-14		"	G-2		104832-0-01	A-46		110673-0-00	B-51	
"	D-23		"	G-9		"	A-63		110686-0-01	B-15	
"	B-16		"	G-21		104833-0-01	H-12		"	E-10	
"	C-5		"	G-52		104908-0-01	E-40		"	E-23	
"	C-31		"	I-9		105034-0-02	C-10		110704-0-01	C-9	
"	C-51		"	I-20		"	C-36		"	C-35	
"	D-10		100242-0-02	A-14		"	E-17		"	E-16	
"	D-55		100251-0-01	D-61		105078-0-01	B-22		110706-0-01	C-14	
"	E-15		100260-0-01	B-4		105079-0-01	B-19		110720-0-01	E-32	
"	E-26		"	H-32		105123-0-01	G-44		110735-0-01	A-8	
"	F-26		100264-0-04	B-66		105163-0-01	D-29		110778-0-01	E-1	
017782-0-14	B-60		100289-0-01	C-2		105173-0-03	H-46		110793-0-01	F-32	
017822-2-13	A-88		100289-0-03	C-28		105228-0-01	G-24		110813-0-01	G-29	
021770-1-03	E-12		100366-0-01	B-9		"	G-32		"	G-66	
022710-1-03	E-35		"	B-13		"	G-59		110815-0-01	G-25	
046301-8-20	H-36		"	E-21		105230-0-01	G-58		"	G-33	
047200-8-47	F-15		100368-0-02	B-47		105234-0-01	E-52		110816-0-01	G-23	
048050-3-47	I-31		100469-0-02	A-56		105827-0-01	C-20		"	G-31	
048080-3-46	F-30		100539-0-03	D-51		106069-0-01	C-25		110820-0-01	G-30	
048170-1-43	D-76		100541-0-01	B-20		"	F-39		"	G-37	
072600-0-30	B-30		"	H-15		106129-0-01	B-61		110821-0-01	G-39	
081004-0-70	I-29		100541-0-02	D-1		107153-0-01	H-33		"	G-60	
100016-0-03	B-49		"	E-44		107244-0-01	B-52		110822-0-01	G-38	
100025-0-01	D-77		"	F-36		107272-0-02	A-28		110832-0-01	G-28	
100032-0-01	A-40		100541-0-03	A-2		107351-0-01	B-59		"	G-36	
"	B-55		"	A-5		107407-0-02	D-86		"	G-63	
100035-0-02	G-14		"	F-10		107491-0-02	G-47		111104-0-01	D-63	
100080-0-03	E-33		100579-0-02	D-21		108721-0-01	G-27		111443-0-01	C-17	
100130-0-01	A-18		100644-0-03	A-84		"	G-35		"	C-30	
"	F-12		100645-0-03	E-70		108721-0-01	G-62		"	E-47	
100137-0-02	A-38		101275-0-04	G-55		109203-0-01	A-89		"	A-97	

MA4-B972

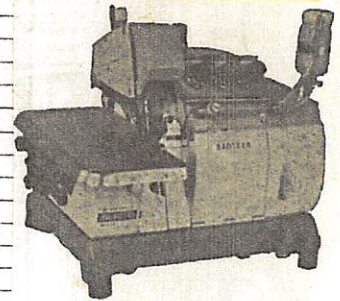

## INDEX

Parts. No.	Ref. No.	Remark	Parts. No.	Ref. No.	Remark	Parts. No.	Ref. No.	Remark	Parts. No.	Ref. No.	Remark
111486-0-01	B-56		140040-0-01	A-17		140105-0-02	B-58		140152-0-01	A-7	
111865-0-01	A-96		140041-0-01	A-15		140106-0-01	B-54		140153-0-01	E-2	
112297-0-16	B-36		140042-0-01	A-12		140108-0-02	J-19		140156-0-01	E-39	
112299-0-01	G-7		140043-0-01	A-9		140108-0-03	B-63		140157-0-01	E-41	
112300-0-01	G-6		140044-0-01	A-66		140109-0-01	A-25		140158-0-00	E-38	
112301-0-01	G-8		140045-0-01	A-37		140110-0-00	A-26		140159-0-00	E-42	
112348-0-01	A-93		140048-0-00	A-39		140111-0-01	C-32~34		140160-0-01	E-46	
/"	H-5		140054-0-02	A-81		140112-0-00	C-8		140161-0-01	E-48	
/"	H-17		140055-0-01	A-83		/"	C-34		140162-0-01	D-65~76	
/"	H-18		140056-0-01	A-82		/"	E-18		140163-0-01	D-66	
/"	H-22		140057-0-01	A-77		140113-0-01	C-32		140165-0-01	D-71	
/"	H-25		140058-0-01	A-76		140114-0-01	C-19		140166-0-01	D-65	
/"	H-29		140060-0-01	A-42		140115-0-01	C-41		140167-0-00	D-70	
/"	I-15		140063-0-01	B-57		140116-0-00	C-1		140168-0-01	D-69	
112351-0-01	H-9		140064-0-01	A-27		/"	C-26		140169-0-01	D-72	
/"	H-26		140065-0-01	A-23		140117-0-01	C-38		140170-0-01	D-73	
112359-0-01	H-21		140066-0-01	A-52		140118-0-00	C-13		140173-0-01	D-74	
112364-0-01	H-13		140067-0-01	A-92		/"	C-39		140174-0-01	D-75	
/"	H-27		140070-0-01	A-60		140119-0-01	C-44		140176-0-01	D-64	
/"	H-30		140071-0-01	A-87		140120-0-01	C-45		140178-0-01	D-9	
112467-0-01	A-94		140072-0-01	A-85		140121-0-01	C-49		140179-0-01	D-8	
113431-0-02	D-3		140075-0-01	A-53		140122-0-01	C-50		140180-0-01	B-44	
114294-0-01	B-65		140077-0-01	A-86		140124-0-01	C-21		140182-0-01	D-78	
114447-0-01	J-4		140083-0-01	A-61		140125-0-01	C-23		140183-0-01	D-80	
/"	J-6		140084-0-00	B-43		140127-0-01	C-48		140184-0-01	D-7	
116231-0-01	A-59		140085-0-02	B-45		140128-0-01	C-46~50		140185-0-00	D-6	
116662-0-01	D-59		140086-0-01	B-11~15		140129-0-01	C-6~8		140186-0-00	D-24	
116778-0-01	C-3		140087-0-01	B-14		140130-0-01	C-6		140187-0-00	A-47	
/"	C-27		140088-0-01	B-11		140133-0-01	E-18~20		140188-0-03	A-48	
117127-0-02	B-67		140089-0-01	B-12		140134-0-01	E-20		140189-0-01	D-36.37	
117515-0-01	E-56		140090-0-01	B-7		140135-0-01	E-29~31		140190-0-01	D-37	
117516-0-01	E-57		140091-0-00	B-17		140136-0-01	E-29		140191-0-01	D-38	
117666-0-01	B-34		140092-0-01	B-8		140137-0-00	E-31		140193-0-01	D-89	
/"	J-2		140093-0-01	B-3		140138-0-01	E-9		140194-0-01	D-88	
/"	K-2		140094-0-01	B-24		140139-0-01	E-28		/"	K-15	
118527-0-01	E-53		140095-0-01	B-1		140140-0-01	E-34		140195-0-01	D-91	
120823-0-01	E-51		140096-0-01	B-26		140141-0-01	E-5~7		140196-0-01	D-18	
140032-0-01	A-32		140097-0-01	B-2		140142-0-01	E-5		140197-0-01	D-84	
140033-0-01	A-31		140098-0-01	B-25		140143-0-00	E-6		140202-0-01	D-28	
140034-0-02	A-4		140099-0-01	B-28		140145-0-00	E-11		140203-0-01	D-39	
140035-0-02	A-1		140100-0-01	B-29		140146-0-01	E-14		140205-0-01	D-22	
140036-0-01	A-6		140101-0-01	K-1		140148-0-01	E-13		140207-0-01	D-35	
140037-0-02	A-13~17		140102-0-01	G-3		140149-0-01	E-8		140208-0-01	D-32	
140038-0-02	A-16		140103-0-01	G-1		140150-0-00	E-36		/"	D-45	
140039-0-01	A-13		140104-0-16	B-35		140151-0-00	E-37		140209-0-01	D-36	

## INDEX

Parts. No.	Ref. No.	Remark	Parts. No.	Ref. No.	Remark	Parts. No.	Ref. No.	Remark	Parts. No.	Ref. No.	Remark
140210-0-01	D-34		140266-0-01	F-9		140311-0-00	H-43		140781-0-01	H-24	
140211-0-01	D-16~19		"	K-3		140312-0-00	H-45		140782-0-01	H-16	
140212-0-01	D-16		140267-0-01	F-14		140313-0-01	E-3		140888-0-01	F-11	
140213-0-01	D-19		140268-0-01	K-3~11		140314-0-01	H-14		140910-0-01	I-13	
140214-0-01	D-18		140269-0-01	K-9		140317-0-00	E-27		140912-0-01	J-13	
140215-0-01	D-44		140270-0-01	F-3		140320-0-00	B-10		"	K-12	
140216-0-01	D-43		"	K-8		140325-0-00	H-4		140913-0-01	A-19	
140217-0-01	D-46		140271-0-01	K-10		140326-0-01	B-6		140928-0-00	D-25	
140226-0-01	D-58		140272-0-01	F-6		"	B-23		140985-0-01	B-53	
140228-0-01	D-4		"	K-11		"	I-10		140987-0-01	B-33	
140229-0-01	D-5		140273-0-01	F-1		140327-0-01	B-18		140988-0-01	J-1	
140230-0-01	E-21~25		"	K-6		"	C-4		140989-0-01	F-1~9	
140231-0-00	E-22		140274-0-01	K-4		"	C-40		140990-0-01	F-4	
140232-0-01	E-24		140275-0-01	F-2		140414-0-01	C-15		140991-0-01	F-5	
140233-0-01	E-25		"	K-7		140415-0-00	B-21		140992-0-01	F-7	
140234-0-01	E-65		140276-0-01	K-5		140416-0-00	C-42		140993-0-01	F-8	
140235-0-00	E-66		140277-0-01	F-37		140417-0-00	A-68		140997-0-01	F-43	
140236-0-01	E-68		140278-0-01	G-40		"	C-43		141183-0-01	A-43	
140237-0-01	E-63		140281-0-01	G-11		140418-0-00	B-5		141188-0-01	D-12	
140238-0-01	E-64		"	G-19		140419-0-00	C-22		142119-0-01	F-40	
140239-0-01	E-62		140282-0-01	G-20		140420-0-00	D-15		142126-0-01	B-33, 34	
140240-0-01	E-60		140284-0-01	G-12		140421-0-01	A-71		142127-0-01	J-1, 2	
140241-0-01	E-59		"	G-22		140425-0-01	B-27		142129-0-01	D-90	
140242-0-01	E-61		140286-0-01	G-42		140456-0-01	J-12		142182-0-01	A-64	
140243-0-01	E-58		140289-0-01	G-10		140468-0-01	H-48		142198-0-01	J-11	
140244-0-01	E-50		140290-0-01	G-56		140708-0-00	C-11		142201-0-01	L-1	
140246-0-01	E-39		140291-0-01	G-53		"	C-37		142229-0-01	I-30	
140247-0-01	E-54		140292-0-01	G-51		140727-0-01	A-41, 42		142241-0-01	J-3	
140249-0-01	F-19		140293-0-01	G-48		140728-0-01	A-41		142243-0-01	J-10	
140250-0-01	F-22		140294-0-01	G-50		140736-0-01	K-1, 2		142244-0-01	J-7	
140251-0-01	F-23		140295-0-01	G-46		140756-0-01	G-65		142245-0-01	J-8	
140252-0-01	F-16		140296-0-01	A-50		140758-0-01	A-91		142246-0-01	J-5	
140253-0-01	F-18		140298-0-01	G-17		140764-0-01	H-3		142249-0-01	J-14	
140254-0-01	F-21		140299-0-01	G-54		140768-0-01	H-23		142250-0-01	J-3~10	
140255-0-01	F-20		140300-0-01	B-42		140771-0-01	D-31		142251-0-01	J-9	
140256-0-02	F-34		140301-0-00	H-31		140772-0-01	D-41		142260-0-01	D-62	
140257-0-02	F-33		140302-0-01	H-31~45		140774-0-00	C-53		142281-0-01	I-16	
140258-0-01	F-35		140303-0-01	H-37		140774-0-01	D-30		142282-0-01	I-11	
140259-0-01	F-29		140304-0-01	H-39		140775-0-01	D-56		142284-0-01	I-19	
140260-0-01	F-28		140305-0-01	H-38		140778-0-01	H-19		142289-0-00	I-6	
140261-0-01	F-27		140306-0-00	H-34		140779-0-01	H-28		142290-0-00	I-7	
140262-0-00	F-31		140307-0-00	H-35		140780-0-01	H-6		142292-0-01	I-17	
140263-0-01	F-25		140308-0-00	H-40		"	H-7		142314-0-01	A-73	
140264-0-01	F-24		140309-0-00	H-41		"	H-20		142316-0-01	I-23	
140265-0-01	F-13		140310-0-01	H-42		140781-0-01	H-8		142318-0-00	I-18	



A

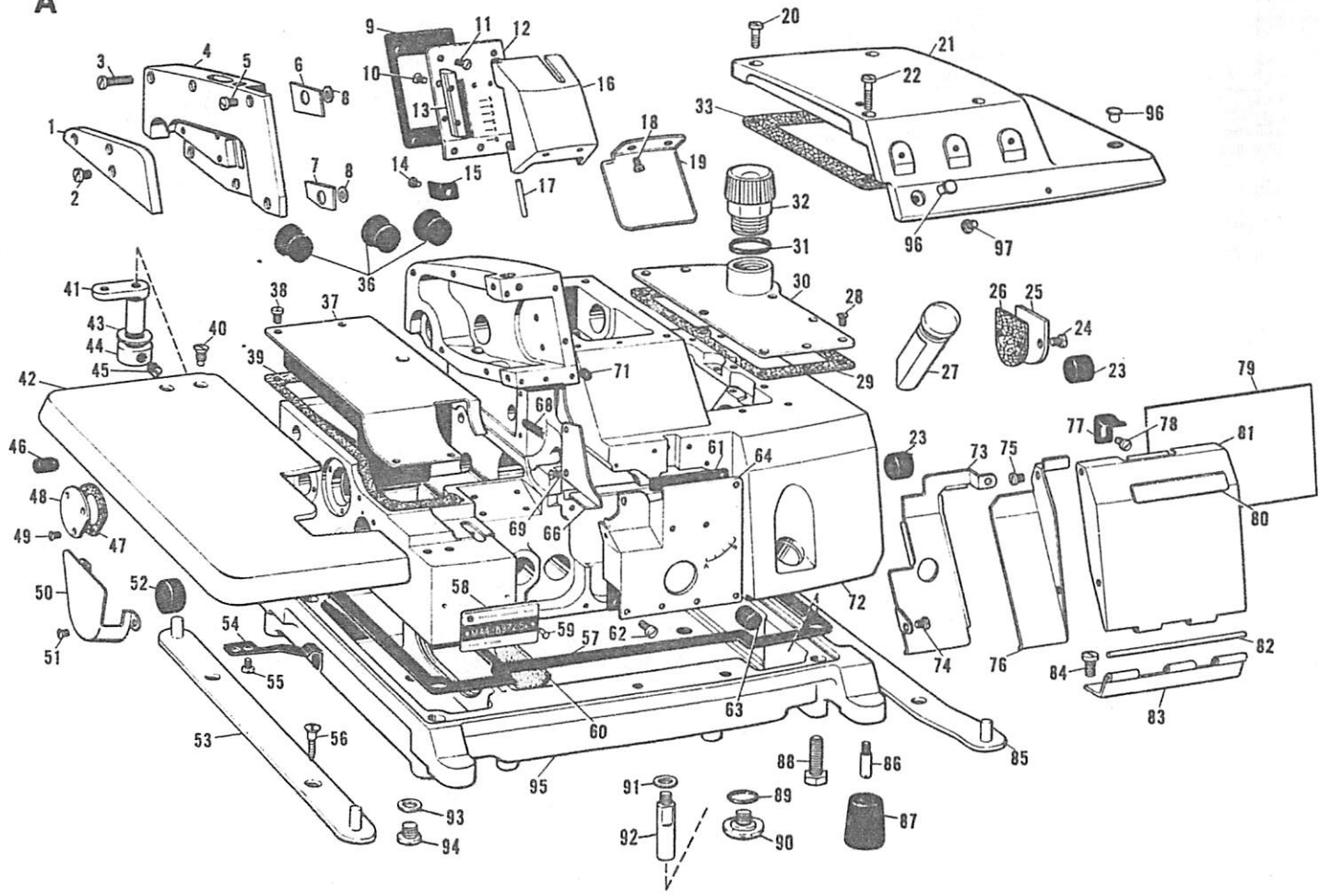

## PARTS LIST for MA4-B972-5A and-5CA

A 3

Ref. No.	Name of Parts	Q'ty	Parts No.	Assembly No.	Ref. No.	Name of Parts	Q'ty	Parts No.	Assembly No.
A-1	Shield for A-4	1 pce.	140035-0-02		A-46	Oil Cap	1 pce.	104832-0-01	
A-2	Set Screw for A-1	3 pcs.	100541-0-03		A-47	Packing for A-48	1 "	140187-0-00	
A-3	Set Screw SM4 37-40x20 for A-4	2 "	009682-0-11		A-48	Cover for Feed Shaft Bushing (Left)	1 "	140188-0-02	
A-4	Cover for Needle Driving Mechanism	1 pce.	140034-0-02		A-49	Flat Head Screw for A-50	3 pcs.	102538-0-06	
A-5	Set Screw for A-4	4 pcs.	100541-0-03		A-50	Cover for G-56	1 pce.	140296-0-01	
A-6	Cover Packing (Upper) for A-4	1 pce.	140036-0-01		A-51	Set Screw for A-50	2 pcs.	100185-0-04	
A-7	Cover Packing (Lower) for A-4	1 "	140152-0-01		A-52	Oil Cap 20.3 $\phi$ x10	1 pce.	140066-0-01	
A-8	Washer for A-4	2 pcs.	110735-0-01		A-53	Cushion Base (Left)	1 "	140075-0-01	
A-9	Face Plate Packing	1 pce.	140043-0-01		A-54	Stopper Spring for A-42	1 "	143375-0-01	
A-10	Flat Head Screw for A-11	2 pcs.	102843-0-04		A-55	Set Screw for A-54	2 pcs.	100185-0-03	
A-11	Flat Head Screw for A-12	5 "	102843-0-04		A-56	Set Screw 5.1x26	4 "	100469-0-02	
A-12	Face Plate	1 pce.	140043-0-01		A-57	Packing for Oil Reservoir	1 pce.	143538-0-01	
A-13	Hinge for A-16	1 "	140039-0-01		A-58	Model Plate (B972-5A)	1 "	143283-0-01	
A-14	Set Screw for A-15	1 "	100242-0-02		A-58	Model Plate (B972-5CA)	1 "	143284-0-01	
A-15	Stopper Spring for A-16	1 "	140041-0-01	140037-0-02	A-59	Pin for A-58	2 pcs.	116231-0-01	
A-16	Needle Thread Take-up Cover	1 "	140038-0-02		A-60	Oil Filter	1 pce.	140070-0-01	
A-17	Pin for A-11	2 pcs.	140040-0-01		A-61	Packing for A-64	1 "	140083-0-01	
A-18	Set Screw for A-19	2 "	100130-0-01		A-62	Set Screw for A-64	5 pcs.	100185-0-04	
A-19	Eye Guard	1 pce.	140913-0-01		A-63	Oil Cap	1 pce.	104832-0-01	
A-20	Set Screw for A-21	2 pcs.	009681-0-14		A-64	Inside Cover	1 "	142182-0-01	
A-21	Top Cover	1 pce.	143292-0-02		A-66	Cloth Guide	1 "	140044-0-01	
A-22	Set Screw for A-21	2 pcs.	009682-0-14		A-68	Wick 6x6	1 "	140417-0-00	
A-23	Oil Cap 14.3 $\phi$ x10	2 "	140065-0-01		A-69	Flat Head Screw for A-66	2 pcs.	100185-0-04	
A-24	Set Screw for A-25	2 "	100185-0-03		A-71	Oil Cap 6.3 $\phi$ x10	1 pce.	140421-0-01	
A-25	Cover for Needle Shaft Bushing (Right)	1 pce.	140109-0-01		A-72	Machine Body	1 "	143550-0-01	
A-26	Packing for A-25	1 "	140110-0-00		A-73	Looper Cover (A)	1 "	142314-0-01	
A-27	Oil Gauge	1 "	140064-0-01		A-74	Set Screw for A-73	2 pcs.	100185-0-04	
A-28	Flat Head Screw for A-30	9 pcs.	107272-0-02		A-75	Set Screw for A-76	2 "	100185-0-04	
A-29	Packing for Dust Cover (Right)	1 pce.	143537-0-00		A-76	Looper Cover (B)	1 pce.	140058-0-01	
A-30	Dust Cover (Right)	1 "	143536-0-01		A-77	Stopper Spring for A-81	1 "	140057-0-01	
A-31	Packing for A-32	1 "	140033-0-01		A-78	Set Screw for A-77	1 "	100185-0-04	
A-32	Cap for Oil Feeding Hole	1 "	140032-0-01		A-79	Threading Diagram for Five Threads	1 "	143782-0-01	
A-33	Packing for A-21	1 "	143293-0-01		A-80	Name Plate	1 "	143774-0-01	
A-36	Oil Cap	3 pcs.	104449-0-01		A-81	Front Cover	1 "	140054-0-02	
A-37	Cover for Feed Mechanism	1 pce.	140045-0-01		A-82	Pin for A-83	1 "	140056-0-01	
A-38	Set Screw for A-37	4 pcs.	100137-0-02		A-83	Hinge for Front Cover	1 "	140055-0-01	
A-39	Packing for A-37	1 pce.	140048-0-00		A-84	Set Screw for A-83	2 pcs.	100644-0-03	
A-40	Flat Head Screw for A-42	2 pcs.	100032-0-01		A-85	Cushion Base (Right)	1 pce.	140072-0-01	
A-41	Cloth Plate Supporter	1 pce.	140728-0-01	140727-0-01	A-86	Set Pin for Cushion	4 pcs.	140077-0-01	
A-42	Cloth Plate	1 "	140060-0-01		A-87	Cushion	4 "	140071-0-01	
A-48	Washer for A-44	1 "	141183-0-00		A-88	Hexagonal Bolt SM 7.94-28x22	4 "	017822-2-13	
A-44	Set Collar for A-41	1 "	110495-0-03		A-89	Rubber Packing for A-90	1 pce.	109203-0-01	
A-45	Set Screw for A-44	2 pcs.	101706-0-01		A-90	Set Screw for A-89	1 "	110641-0-01	



**B**

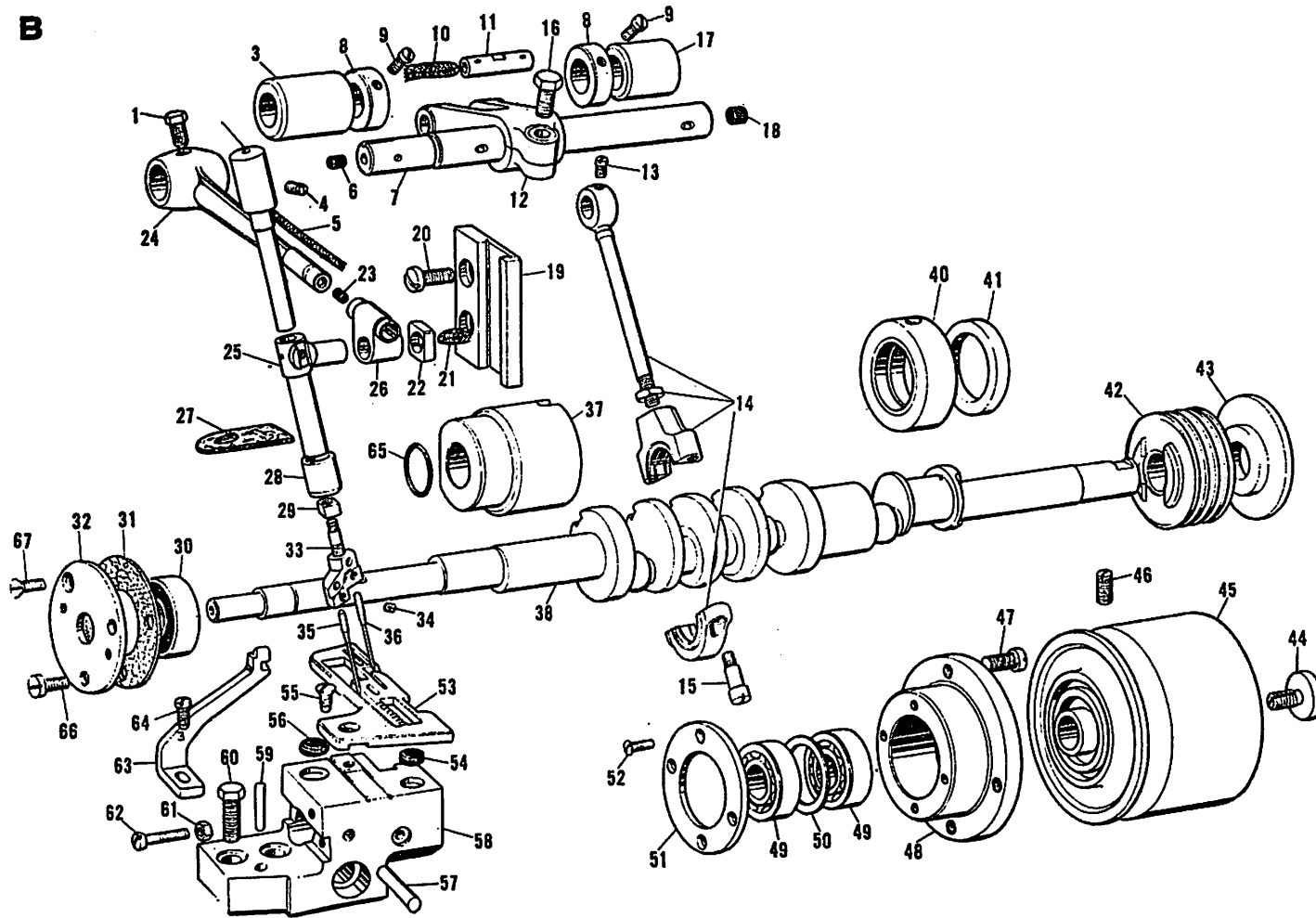



PARTS LIST for MA4-B972-5A and-5CA

B 5

Ref. No.	Name of Parts	Q'ty	Parts No.	Assembly No.	Ref. No.	Name of Parts	Q'ty	Parts No.	Assembly No.
B-1	Set Screw for B-24	1 pce.	140095-0-01		B-45	Pulley	1 pcs.	140085-0-02	
B-2	Needle Bar Bushing (Upper)	1 /	140097-0-01		B-46	Set Screw for B-45	2 /	100016-0-03	
B-3	Needle Shaft Bushing (Left)	1 /	140093-0-01		B-47	Set Screw for B-48	4 /	100368-0-02	
B-4	Set Screw for B-3	1 /	100260-0-01		B-48	Bearing Case	1 pce.	110670-0-00	
B-5	Wick 6x6 (56)	1 /	140418-0-00		B-49	Bearing 6001	2 pcs.	110671-0-00	
B-6	Oil Cap 3.3φx5	1 /	140326-0-01		B-50	Thrust Washer	1 pce.	110672-0-00	
B-7	Needle Shaft	1 /	140090-0-01		B-51	Bearing Cover	1 /	110673-0-00	
B-8	Set Coller for B-7	2 pcs.	140092-0-01		B-52	Set Screw for B-51	4 pcs.	107244-0-01	
B-9	Set Serew for B-8	4 /	100366-0-01		B-53	Needle plate	1 pce.	140985-0-01	
B-10	Wick 6x6 (52)	1 pce.	140320-0-00		B-54	Cloth Puate Cushion (A)	1 /	140106-0-01	
B-11	Phn for B-12	1 /	140088-0-01		B-55	Set Screw for B-55	1 /	100032-0-01	
B-12	Needle Arm Driving Lever	1 /	140089-0-01		B-56	Cloth Plate Cushion (B)	1 /	111486-0-01	
B-13	Set Screw for B-14	1 /	100366-0-01	140086-0-01	B-57	Dowel Pin	1 /	140063-0-01	
B-14	Needle Arm Driving Crank Assembly	1 /	140087-0-01		B-58	Needla Plate Support Bracket	1 /	140105-0-02	
B-15	Set Screw for B-14	2 pcs.	110686-0-01		B-59	Taper Pin 3.5x24	1 /	107351-0-01	
B-16	Hexagonal Bolt SM 6.35-40x14	1 pce.	017771-4-10		B-60	Hexagonal Bolt SM6.35-28x20	2 pcs.	017782-0-14	
B-17	Needle Shaft Bushng (Right)	1 /	140091-0-00		B-61	Nut for B-62	1 pce.	106129-0-01	
B-18	Oil Cap 6.3φx5	1 /	140327-0-01		B-62	Set Screw for B-58	1 /	101552-2-01	
B-19	Needle Bar Guide	1 /	105079-0-01		B-63	Overlock Stitch Needle Guard	1 /	140108-0-03	
B-20	Set Screw for B-19	2 pcs.	100541-0-01		B-64	Set Screw for B-63	1 /	100137-0-02	
B-21	Wick 4x4 (30)	1 pce.	140415-0-00		B-65	Packing	1 /	114294-0-01	
B-22	Slide Block for B-19	1 /	105078-0-01		B-66	Set Screw for B-32	2 pcs.	100264-0-04	
B-23	Oil Cap 3.3φx5	1 /	140326-0-01		B-67	Set Screw for B-32	1 pce.	117127-0-02	
B-24	Needle Arm	1 /	140094-0-01						
B-25	Needle Bar	1 /	140098-0-01						
B-26	Needle Bar Connector	1 /	140096-0-01						
B-27	Felt for B-28	1 /	140425-0-01						
B-28	Needle Bar Bushing (Lower)	1 /	140099-0-01						
B-29	Nut for B-33	1 /	140100-0-01						
B-30	Bearing 6000D	1 /	072600-0-30						
B-31	Packing for B-32	1 /	143312-0-00						
B-32	Bearing Plate	1 /	143524-0-00						
B-33	Needle Clamp (5mm)	1 /	140987-0-01	142126-0-01					
B-34	Needle Set Screw for B-33	2 pcs.	117666-0-01						
B-35	Needle DMx13	1 pce.	140104-0-16						
B-36	Needle DCx1	1 /	112297-0-16						
B-37	Crank Shaft Bushing (Left)	1 /	143174-0-01						
B-38	Crank Shaft	1 /	143173-0-01						
B-39	Set Screw for B-41	1 /	110668-0-01						
B-40	Crank Shaft Bushng (Centre)	1 /	143179-0-01						
B-41	Ring for B-40	1 /	143182-0-01						
B-42	Worm	1 /	140300-0-01						
B-43	Oil Rejector	1 /	140084-0-00						
B-44	Cap Screw for B-45	1 /	140180-0-01						

C

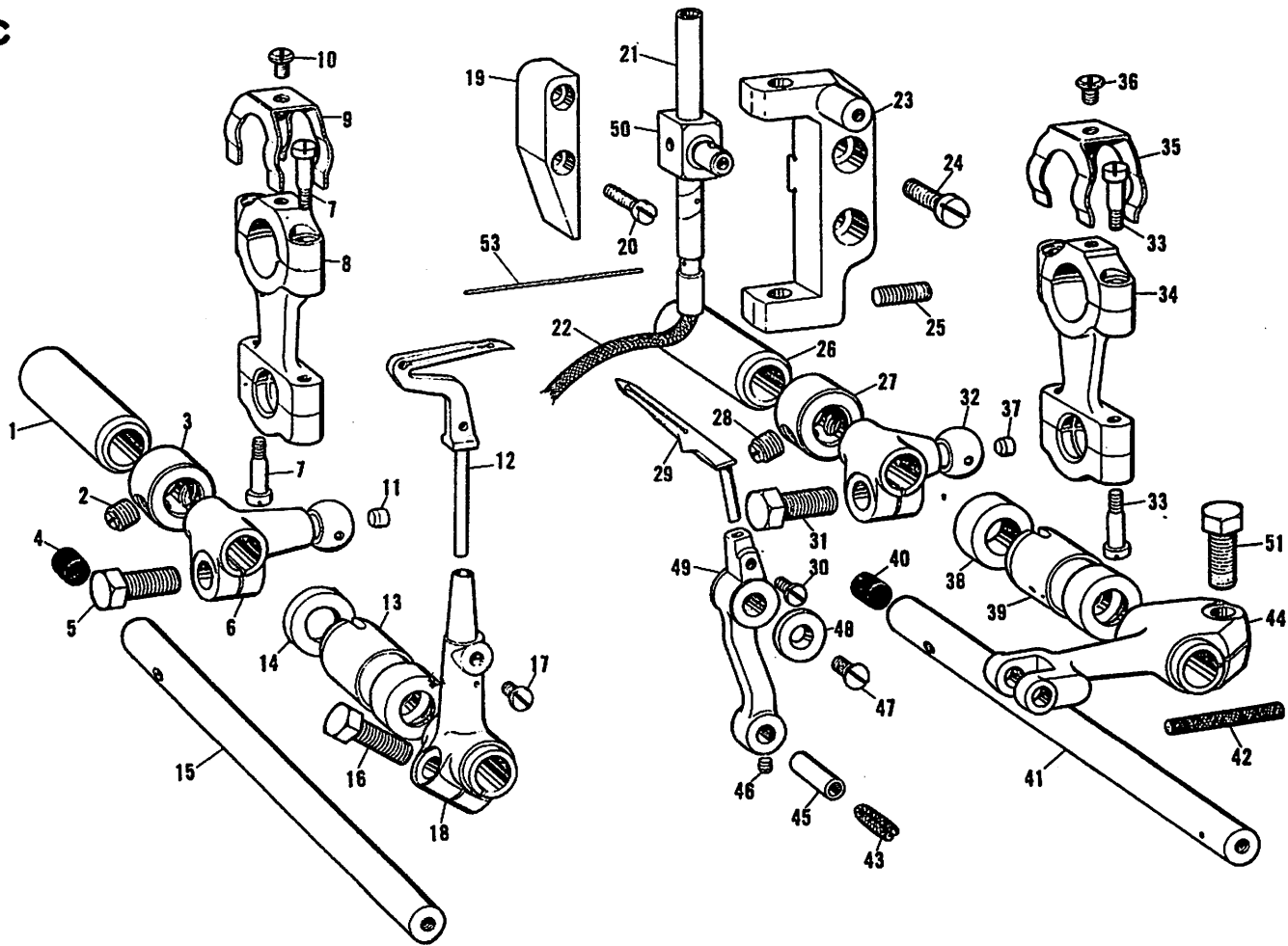

PARTS LIST for MA4-B972-5A and-5CA

C7

Ref. No.	Name of Parts	Q'ty	Parts No.	Assembly No.	Ref. No.	Name of Parts	Q'ty	Parts No.	Assembly No.
C-1	Connecting Rod Bushing (Rear)	1 pce.	140116-0-00		C-46	Set Screw for C-45	1 pec.	104651-0-01	
C-2	Set Screw for C-3	2 pcs.	100289-0-01	180323-0-01	C-47	Flat Head Screw SM 3.57-40×6	1 //	003670-6-14	
C-3	Set Collar	1 pce.	116778-0-01		C-48	Washer for C-49	1 //	140127-0-01	140128-0-01
C-4	Oil Cap 6.3φ×5	1 //	140327-0-01		C-49	OverLooper Holder	1 //	140121-0-01	
C-5	Hexagonal Bolt SM 6.35-40×14	1 //	017771-4-12		C-50	OverLooper Holder Slide Block	1 //	140122-0-01	
C-6	Under Looper Supporter	1 //	140130-0-01		C-51	Hexagonal Bolt SM 6.35-40×14	1 //	017771-4-12	
C-7	Set Screw for C-8	4 pcs.	142590-0-01	140129-0-01	C-53	Long Pin 0.32×70	2 pcs.	140774-0-00	
C-8	Looper Connecting Rod	1 pce.	140112-0-00						
C-9	Looper Connecting Rod Stopper	1 //	110704-0-01						
C-10	Set Screw for C-9	1 //	105034-0-02						
C-11	Oil Cap 3.5φ×3	1 //	140708-0-00						
C-12	Under Looper	1 //	143734-0-01						
C-13	Connecting Rod Bushing (Front)	1 //	140118-0-00						
C-14	Thrust Collar for C-15	1 //	110706-0-01						
C-15	Shaft for C-6	1 //	140414-0-01						
C-16	Hexagonal Bolt SM 5.56-32×14	1 //	017751-4-13						
C-17	Set Screw for C-12	1 //	111443-0-01						
C-18	Under Looper Holder	1 //	143758-0-01						
C-19	Guide for C-22	1 //	140114-0-00						
C-20	Set Screw for C-19	2 pcs.	105827-0-01						
C-21	Over Looper Holder Guide Shaft	1 pce.	140124-0-01						
C-22	Wick 6×6 (90)	1 //	140419-0-00						
C-23	Supporting Block for C-21	1 //	140125-0-01						
C-24	Set Screw SM 4.76-32×10	2 pcs.	009711-0-13						
C-25	Set Screw for C-21	1 pce.	106069-0-01						
C-26	Connecting Rod Bushing (Rear)	1 //	140116-0-00						
C-27	Set Collar for C-26	1 //	116778-0-01	180323-0-01					
C-28	Set Screw for C-27	2 pcs.	100289-0-03						
C-29	Over Looper	1 pce.	143733-0-01						
C-30	Set Screw for C-29	1 //	111443-0-01						
C-31	Hexagonal Bolt SM 6.35-40×14	1 //	017771-4-12						
C-32	Over Looper Supporter	1 //	140113-0-01						
C-33	Set Screw for C-34	4 pcs.	142590-0-01	140111-0-01					
C-34	Looper Connecting Rod	1 //	140112-0-00						
C-35	Looper Connecting Rod Stopper	1 //	110704-0-01						
C-36	Set Screw for C-35	1 //	105034-0-02						
C-37	Oil Cap 3.5φ×3	1 //	140708-0-00						
C-38	Thrust Collar for C-41	1 //	140117-0-01						
C-39	Connecting Rod Bushing (Front)	1 //	140118-0-00						
C-40	Oil Cap 6.3φ×5	1 //	140327-0-01						
C-41	Shaft for C-32	1 //	140115-0-01						
C-42	Wick 6×6 (27)	1 //	140416-0-00						
C-43	Wick 6×6 (32)	1 //	140417-0-00						
C-44	Over Looper Driving Lever	1 //	140119-0-01						
C-45	Pin for C-49	1 //	140120-0-01						

**D**

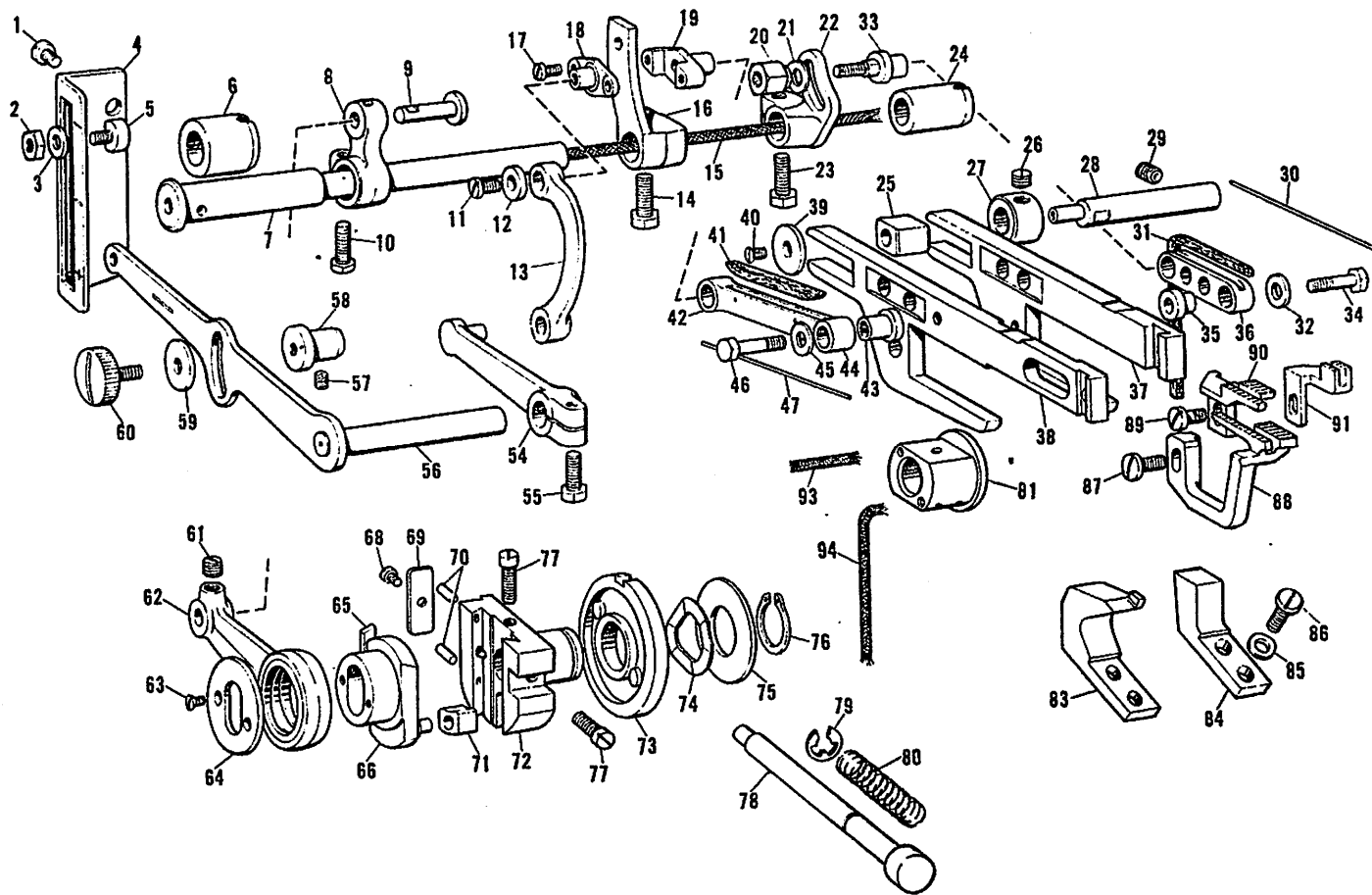

## PARTS LIST for MA4-B972-5A and-5CA

D9

Ref. No.	Name of Parts	Q'ty	Parts No.	Assembly No.	Ref. No.	Name of Parts	Q'ty	Parts No.	Assembly No.
D-1	Set Screw for D-4	2 pcs.	100541-0-02		D-54	Differenceential Feed Link Lever	1 pce.	142588-0-01	
D-2	Nut for D-5	2 /	110161-0-04		D-55	Hexagonal Bolt SM 635.-40x14	1 /	117771-4-12	
D-3	Washer for D-2	2 /	113431-0-02		D-56	Differenceential Adjusting Lever	1 /	140775-0-01	
D-4	Differenceential Stitch Control	1 pce.	140228-0-01		D-57	Set Screw for D-58	1 /	100539-0-03	
D-5	Stopper Screw for D-4	2 pcs.	140229-0-01		D-58	Bushing for D-56	1 /	140226-0-01	
D-6	Feed Shaft Bushing (Left)	1 pce.	140185-0-00		D-59	Washer D-60	1 /	116662-0-01	
D-7	Feed Shaft	1 /	140184-0-01		D-60	Set Screw for D-56	1 /	143287-0-01	
D-8	Feed Arm	1 /	140179-0-01		D-61	Set Screw for D-62	1 /	100251-0-01	
D-9	pin for D-8	1 /	140178-0-01		D-62	Feed Rod	1 /	142260-0-01	
D-10	Hexagonal BM 6.35-40x14	1 /	017771-4-12		D-63	Set Screw for D-64	2 pcs.	111104-0-01	
D-11	Set Screw for D-13	1 /	003670-6-14		D-64	Feed Rod Presser Plate	1 pce.	140176-0-01	
D-12	Washer for D-13	1 /	141188-0-01		D-65	Gib	1 /	140166-0-00	
D-13	Differenceential Feed Adjusting Ring	1 /	142589-0-01		D-66	Eccentric Wheel	1 /	140163-0-01	
D-14	Hexagonal Bolt SM 6.35-40x12	1 /	017771-2-12		D-68	Set Screw for D-69	1 /	104767-0-02	
D-15	Wick 6x6 (135)	1 /	140420-0-01		D-69	Gib Holder Plate	1 /	140168-0-01	
D-16	Differenceential Feed Arm	1 /	140212-0-01		D-70	Gib Holder Pin	2 pcs.	140167-0-00	
D-17	Set Screw for D-18	2 pcs.	109836-0-01	140211-0-01	D-71	Slide Block for D-72	1 pce.	140165-0-01	
D-18	Cap for D-19	1 pce.	140214-0-01		D-72	Eccentric Wheel Holder	1 /	140169-0-01	
D-19	Differenceential Feed Adjuster	1 /	140213-0-01		D-73	Eccentric Wheel Adjusting Cam 3.6mm	1 /	140170-0-01	140162-0-01
D-20	Nut for D-33	1 /	143565-0-01		D-74	Ripple Spring	1 /	140173-0-01	
D-21	Washer for D-20	1 /	100579-0-02		D-75	Spring Presser Ring	1 /	140174-0-01	
D-22	Main Feed Arm	1 /	140205-0-01		D-76	Stop Ring	1 /	048170-1-43	
D-23	Hexagonal SM6.35-40x12	1 /	017771-2-12		D-77	Set Screw for D-72	2 pcs.	100025-0-01	
D-24	Feed Shaft Bushing (Right)	1 /	140186-0-00		D-78	Feed Adjusting Shaft	1 pce.	140182-0-01	
D-25	Feed Bar Guide Block	1 /	140928-0-00		D-79	Stop Ring	1 /	109574-0-01	
D-26	Set Screw for D-27	2 pcs.	101706-0-01	181995-0-01	D-80	Feed Adjusting Spring	1 /	140183-0-01	
D-27	Set Collar for D-28	1 pce.	104521-0-01		D-81	Feed Lifting Slide Block	1 /	140196-0-00	
D-28	Feed Bar Guide Block Shaft	1 /	140202-0-01		D-83	Feed Bar Guide (Left)	1 /	142574-0-01	
D-29	Set Screw for D-28	1 /	105163-0-01		D-84	Feed Bar Guide (Right)	1 /	140197-0-01	
D-30	Steel Wire 0.32x100	1 /	140774-0-01		D-85	Washer for D-86	4 pcs.	403387-0-01	
D-31	Felt for D-36	1 /	140771-0-01		D-86	Set Scw for D-84	4 /	107407-0-02	
D-32	Washer for D-33	1 /	140208-0-01		D-87	Set Screw for D-88	1 pce.	009681-2-12	
D-33	Main Feed Link Shaft (Large)	1 /	143564-0-01		D-88	Differenceential Feed Dog	1 /	140194-0-01	
D-34	Main Feed Link Shaft (Small)	1 /	140210-0-01		D-89	Set Screw for D-90	1 /	140193-0-01	
D-35	Main Feed Link Bushing	1 /	140207-0-01		D-90	Main Feed Dog	1 /	142129-0-01	
D-36	Main Feed Link	1 /	140209-0-01	140189-0-01	D-91	Chain Feed Dog	1 /	140195-0-01	
D-37	Main Feed Bar	1 /	140190-0-01		D-93	Wick 3x3 (20)	1 /	142673-0-00	
D-38	Differenceential Feed Bar	1 /	140191-0-01		D-94	Wick 3x3 (130)	1 /	142674-0-00	
D-39	Slide Plate for D-25	1 /	140203-0-01						
D-40	Round Head Screw SM3.18-40x7	1 /	005660-7-13						
D-41	Felt for D-44	1 /	140772-0-01						
D-43	Differenceential Feed Link Bushing	1 /	140216-0-01						
D-44	Differenceential Feed Link	1 /	140215-0-01						
D-45	Washer for D-44	1 /	140208-0-01						
D-46	Feed Link Shaft (Large)	1 /	140217-0-01						



E

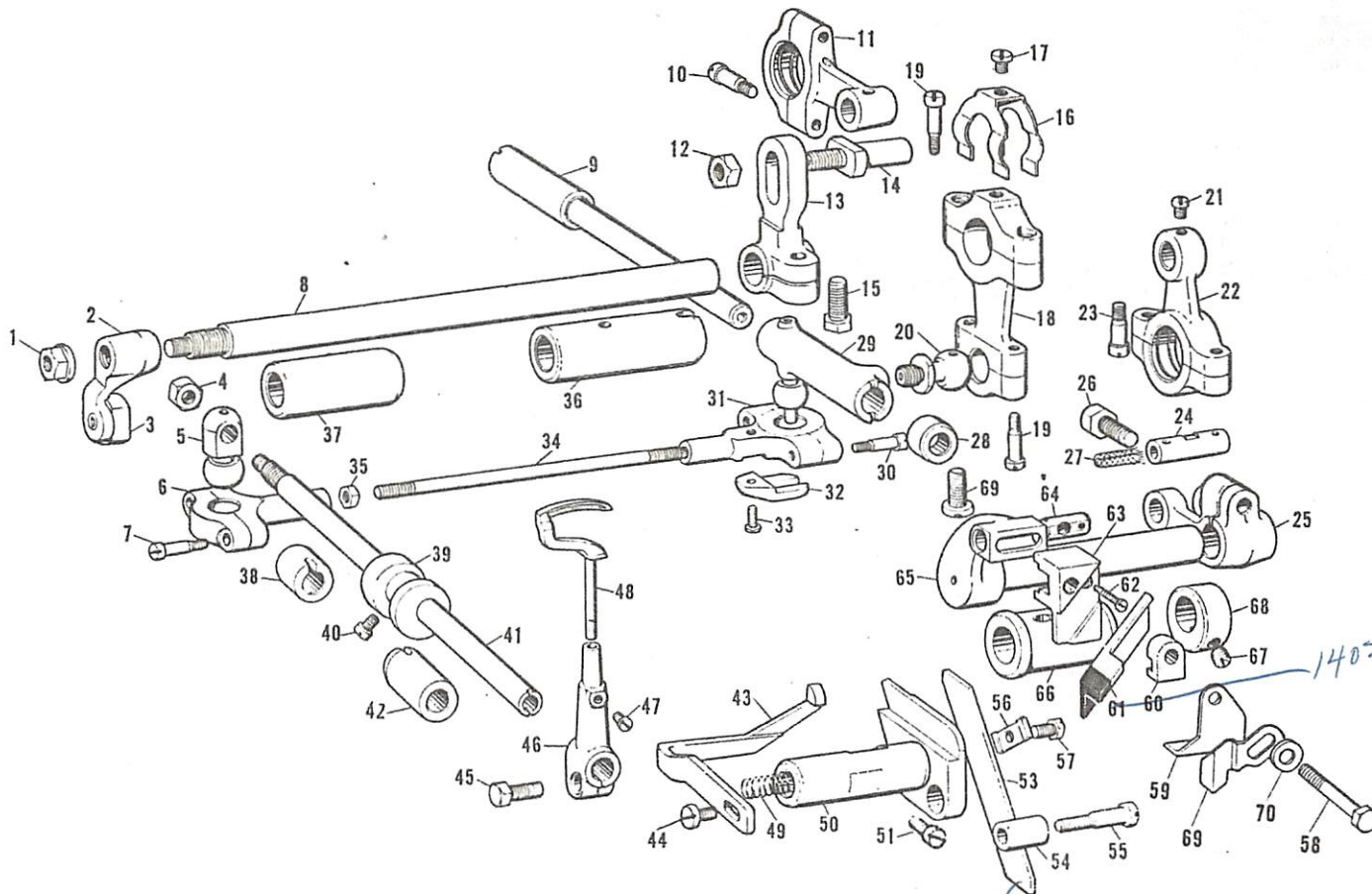

11857-0-01

140242-0-01



## PARTS LIST for MA4-B972-5A and-5CA

E11

Ref. No.	Name of Parts	Q'ty	Parts No.	Assembly No.	Ref. No.	Name of Parts	Q'ty	Parts No.	Assembly No.
E-1	Nut for E-2	1 pce.	110778-0-01		E-44	Set Scre w for E-43	1 pce.	100541-0-02	
E-2	Longitudinal Feed Lever	1 //	140153-0-01		E-45	Hexagonal Bolt Bolt SM 5.56-32x14	1 //	017751-4-13	
E-3	Slide Block for E-2	1 //	140313-0-01		E-46	Chain Stitch Looper Holder	1 //	140160-0-01	
E-4	Nut for E-5	1 //	100176-0-01		E-47	Set Screw for E-48	1 //	111443-0-01	
E-5	Connecting Levr (Left)	1 //	140142-0-01		E-48	Chain Stich Looper	1 //	140161-0-01	
E-6	Connecting Lever Rod (Left)	1 //	140143-0-00	140141-0-01	E-49	Lower Knife Holder Spring	1 //	140246-0-01	
E-7	Set Screw for E-6	2 pcs.	142590-0-01		E-50	Lower Knife Holder	1 //	140244-0-01	
E-8	Longitudinal Feed Lever Shaft for Chain Stitch	1 pce.	140149-0-01		E-51	Set Screw for E-50	1 //	120823-0-01	
E-9	Connecting Lever Shaft	1 //	140138-0-01		E-53	Lower Knife	1 //	118527-0-01	
E-10	Set Screw for E-11	2 pcs.	110686-0-01		E-54	Lower Knie Holder Guide	1 //	140247-0-01	
E-11	Longitudinal Feed Driving Rod for Chain Stitch Looper	1 pce.	140145-0-00		E-55	Set Screw for E-54	1 //	104215-0-01	
E-12	Hexagonal Nut SM 6.35-40x12	1 //	021770-1-03		E-56	Lower Knife Holding Plate	1 //	117515-0-01	
E-13	Driving Lever for E-6	1 //	140148-0-01		E-57	Set Screw for E-56	1 //	117516-0-01	
E-14	Pin for E-11	1 //	140146-0-01		E-58	Set Screw for E-63	1 //	140243-0-01	
E-15	Hexagonal Bolt SM 6.35-40x12	1 //	017771-4-12		E-59	Upper Knije Clamp (B)	1 //	140241-0-01	
E-16	Looper Connecting Rod Stopper	1 //	110704-0-01		E-60	Upper Knife Fastener	1 //	140240-0-01	
E-17	Set Screw for E-16	1 //	105034-0-02		E-61	Upper Knife (B)	1 //	140242-0-01	
E-18	Looper Donnecting Rod	1 //	140112-0-00		E-62	Set Screw for E-63	1 //	140239-0-01	
E-19	Set Screw for E-18	4 pcs.	142590-0-01	140133-0-01	E-63	Upper KnifeHolding Block	1 //	140237-0-01	
E-20	Ball Joint for E-18	1 pce.	140134-0-01		E-64	Nut for E-63	1 //	140238-0-01	
E-21	Set Screw for E-22	1 //	100366-0-01		E-65	Upper Knife Driving Arm	1 //	140234-0-01	
E-22	Upper Knife Driving Rod	1 //	140231-0-00		E-66	Bushing for E-65	1 //	140235-0-00	
E-23	Set Screw for E-22	2 pcs.	110686-0-01	140230-0-00	E-67	Set Screw SM 5.56-32x6	2 pcs.	013750-6-14	
E-24	Pin for E-21	1 pce.	140232-0-01		E-68	Set Collar for E-65	1 pce.	140236-0-01	
E-25	Upper Knife Driving Lever	1 //	140233-0-01		E-69	Upper Knife Guard	1 //	143442-0-01	
E-26	Hexagonal Bolt SM 6.35-40x14	1 //	017771-4-12		E-70	Washer for E-69	1 //	100645-0-03	
E-27	Wick 6x6 (44)	1 //	403717-0-00						
E-28	Thrust Collar	1 //	140139-0-01						
E-29	Connecting Lever (Right)	1 //	140136-0-01						
E-30	Set Screw for E-31	2 pcs.	142590-0-01	140135-0-01					
E-31	Connecting Lever Rod (Right)	1 pce.	140137-0-00						
E-32	Guide for E-31	1 //	110720-0-01						
E-33	Set Screw for E-22	1 //	100080-0-03						
E-34	Connecting Bar for E-31, 36	1 //	140140-0-01						
E-35	Hexagoal Nut SM 4.76-32	1 //	022710-1-03						
E-36	Bushing (Right) for E-8	1 //	140150-0-00						
E-37	Bushing (Left) for E-8	1 //	140151-0-00						
E-38	Bushing (Rear) or E-41	1 //	140158-0-00						
E-39	Longitudinal Feed Cam	1 //	140156-0-01						
E-40	Set Screw for E-39	2 pcs.	104908-0-01						
E-41	Longitudinal Feed Shaft	1 pce.	140157-0-01						
E-42	Bushing (Front) for E-41	1 //	140159-0-00						
E-43	Chain Stitch Needle Guard	1 //	140997-0-01						

F

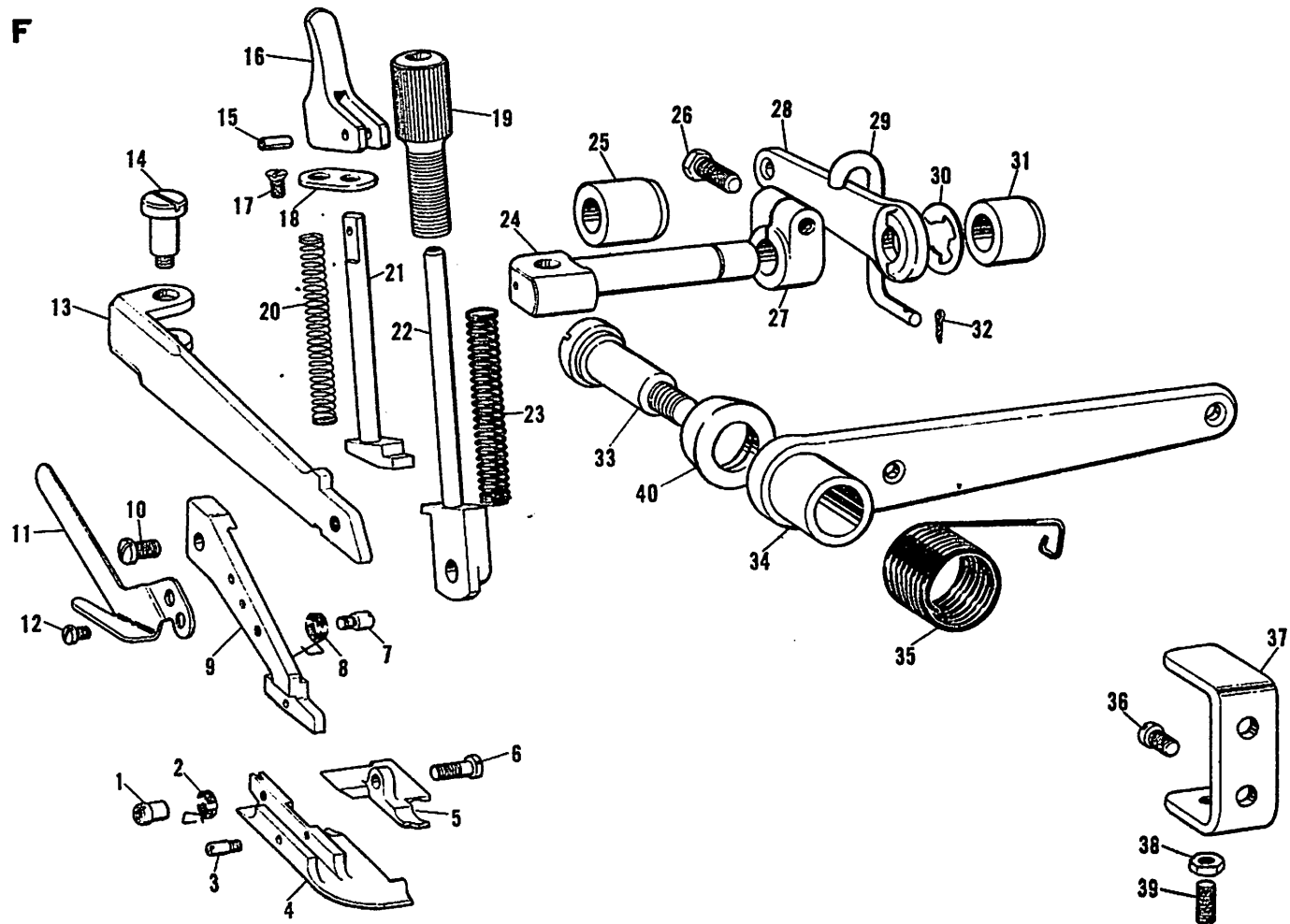

PARTS LIST for MA4-B972-5A and-5CA

F13

Ref. No.	Name of Parts	Q'ty	Parts No.	Assembly No.	Ref. No.	Name of Parts	Q'ty	Parts No.	Assembly No.
F- 1	Screw Nut for F-6	1 pce.	140273-0-00						
F- 2	Spring for F-5	1 "	140275-0-01						
F- 3	Set Screw for F-4	1 "	140270-0-01						
F- 4	Presser Foot (Front)	1 "	140990-0-01						
F- 5	Presser Foot (Rear)	1 "	140991-0-01	140989-0-01					
F- 6	Set Screw for F-5	1 "	140272-0-01						
F- 7	Set Screw for F-8	1 "	140992-0-01						
F- 8	Spring for F-4	1 "	140993-0-01						
F- 9	Sub-presser Arm	1 "	140266-0-01						
F-10	Set Screw for F-9	1 "	100541-0-03						
F-11	Trimming Knife	1 "	140888-0-01						
F-12	Set Screw for F-11	2 pcs.	100130-0-01						
F-13	Main Presser Arm	1 pce.	140265-0-01						
F-14	Stud Screw for F-13	1 "	140267-0-01						
F-15	Spring Pin AW 2x8	1 "	047200-8-47						
F-16	Presser Bar Lifter	1 "	140252-0-01						
F-17	Flat Head Screw for F-18	1 "	102843-0-01						
F-18	Washer for F-16	1 "	140253-0-01						
F-19	Presser Foot Adjusting Screw	1 "	140249-0-01						
F-20	Spring for F-21	1 "	140255-0-01						
F-21	Presser Bar Lifting Shaft	1 "	140254-0-01						
F-22	Presser Bar	1 "	140250-0-01						
F-23	Presser Bar Spring	1 "	140251-0-01						
F-24	Presser Arm Shaft	1 "	140264-0-01						
F-25	Bushing for F-24	1 "	140263-0-00						
F-26	Hexagonal Bolt SM 6.354-0x14	1 "	017771-4-12						
F-27	Set Collar for F-24	1 "	140261-0-01						
F-28	Presser Foot Lifter Inside Lever	1 "	140260-0-01						
F-29	Presser Foot Lifter Ring	1 "	140259-0-01						
F-30	Stop Ring	1 "	048080-3-46						
F-31	Bushing (Right) for F-24	1 "	140262-0-00						
F-32	Cotter Pin	1 "	110793-0-01						
F-33	Presser Foot Lifter Lever Stud	1 "	140257-0-02						
F-34	Presser Foot Lifter Lever	1 "	140256-0-02						
F-35	Spring for F-34	1 "	140258-0-01						
F-36	Set Screw for F-37	2 pcs.	100541-0-02						
F-37	Adjuster for F-34	1 pce.	140277-0-01						
F-38	Nut for F-39	1 "	110161-0-03						
F-39	Stopper Screw for F-34	1 "	106069-0-01						
F-40	Cap for F-33	1 "	142119-0-01						

G

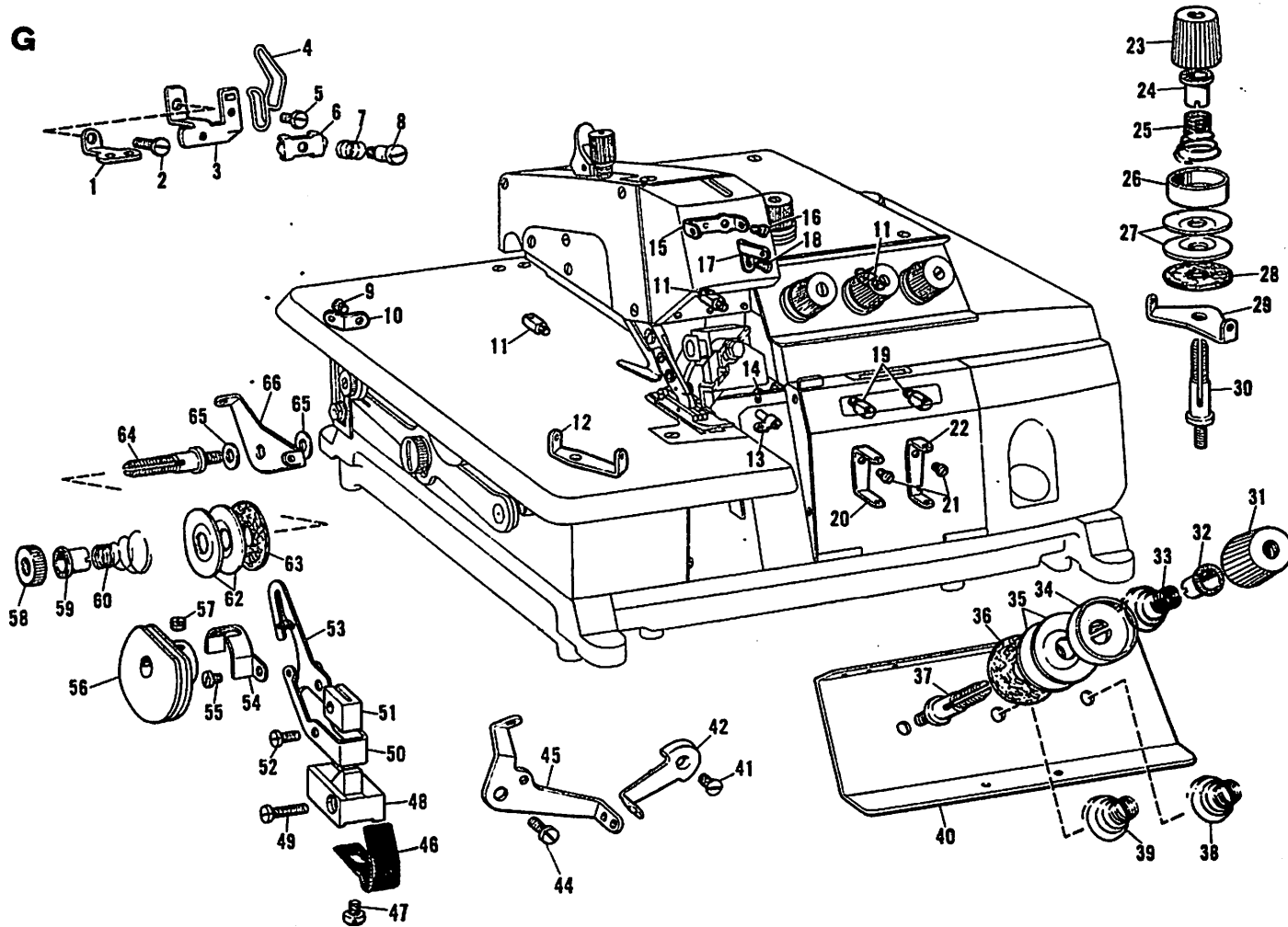

## PARTS LIST for MA4-B972-5A and-5CA

G15

Ref. No.	Name of Parts	Q'ty	Parts No.	Assembly No.	Ref. No.	Name of Parts	Q'ty	Parts No.	Assembly No.
G-1	Needle Thread Guide (B)	1 pce.	140103-0-01		G-39	Over Looper Thread Tension Adjusting Srring	1 pce.	110821-0-01	
G-2	Set Screw for G-1, 3	1 /	100185-0-04		G-40	Thread Guide plate	1 /	140278-0-01	
G-3	Needle Thread Take-up Supporter	1 /	140102-0-01		G-41	Flat Head Screw SM 3.57-40x6	1 /	003670-6-14	
G-4	Needle Thread Take-up	1 /	142602-0-01		G-42	Looper Thread Take-up (Right)	1 /	140286-0-01	
G-5	Set Screw for G-4	1 /	009669-3-13		G-44	Set Screw for G-45	1 /	105123-0-01	
G-6	Needle Thread Guard	1 /	112300-0-01		G-45	Looper Thread Take-up (Left)	1 /	143768-0-01	
G-7	Needle Thread Guard Spring	1 /	112299-0-01		G-46	Spring Plate for G-50	1 /	140295-0-01	
G-8	Stud Screw for G-6	1 /	112301-0-01		G-47	Set Screw for G-46	1 /	107491-0-02	
G-9	Set Screw for G-10	1 /	100185-0-04		G-48	Bracket for G-50	1 /	140293-0-01	
G-10	Thread Guide (A) for Chain Stitch Looper	1 /	140289-0-01		G-49	Set Screw SM 3.57-40x16	1 /	009671-6-03	
G-11	Looper Thread Guide	3 pcs.	140281-0-01		G-50	Thread Guide for Chain Stich Looper	1 /	140294-0-01	
G-12	Under Looper Thread Guide (B)	1 pce.	140284-0-01		G-51	Holder for G-53	1 /	140292-0-01	
G-13	Over Looper Thread Guide (B)	1 /	142669-0-01		G-52	Set Screw for G-53	1 /	100137-0-04	
G-14	Set Screw for G-13	1 /	100035-0-02		G-53	Thread Handler for Chain Stich Looper	1 /	140291-0-01	
G-15	Needle Thread Guide (A)	1 /	143757-0-01		G-54	Thread Protector	1 /	140299-0-01	
G-16	Set Screw for G-15	1 /	403865-0-02		G-55	Set Screw for G-54	2 pcs.	101275-0-04	
G-17	Needle Thread Guide for Chain Stich	1 /	140298-0-01		G-56	Chain Stich Looper Take-up	1 pce.	140290-0-01	
G-18	Set Screw for G-17	1 /	100137-0-03		G-57	Set Screw for G-56	2 pcs.	102716-0-03	
G-19	Looper Thread Guide	2 pcs.	140281-0-01		G-58	Thread Tension Adjusting Nut	1 pce.	105230-0-01	
G-20	Over Looper Thread Guide (A)	1 pce.	140282-0-01		G-59	Tension Spring Washer	1 /	105228-0-01	
G-21	Set Screw for G-20, 22	1 /	100185-0-04		G-60	Chain Stich Thread Tension Adjusting Spring	1 /	110821-0-01	
G-22	Under Looper Thread Guide (A)	1 /	140284-0-01		G-62	Tension Disc	2 pcs.	108721-0-01	
G-23	Thread Tension Adjusting Screw	1 /	110816-0-01		G-63	Felt for G-62	1 pce.	110832-0-01	
G-24	Tension Spring Washer	1 /	105228-0-01		G-64	Looder Thread Tension Control Stud	1 /	143286-0-01	
G-25	Needle Thread Tension Adjusting Spring	1 /	110815-0-01		G-65	Packing for G-66	1 /	140756-0-01	
G-26	Tension Disc Washer	1 /	109814-0-01		G-66	Chain Stich Thread Guide Plate	1 /	110813-0-01	
G-27	Tension Disc	2 pcs.	108721-0-01						
G-28	Felt for G-27	1 pce.	110832-0-01						
G-29	Needle Thread Guide Plate	1 /	110813-0-01						
G-30	Looper Thread Tension Control Stud	1 /	110820-0-01						
G-31	Thread Tension Adjusting Screw	3 pcs.	110816-0-01						
G-32	Tension Spring Washer	3 /	105228-0-01						
G-33	Needle Thread Tension Adjusting Spring	1 pce.	110815-0-01						
G-34	Tension Disc Washer	3 pcs.	109814-0-01						
G-35	Tension Disc	6 /	108721-0-01						
G-36	Felt for G-35	3 /	110832-0-01						
G-37	Looper Thread Tension Control Stud	3 /	110820-0-01						
G-38	Under Looper Thread Tension Adjusting Spring	1 pce.	110822-0-01						

H

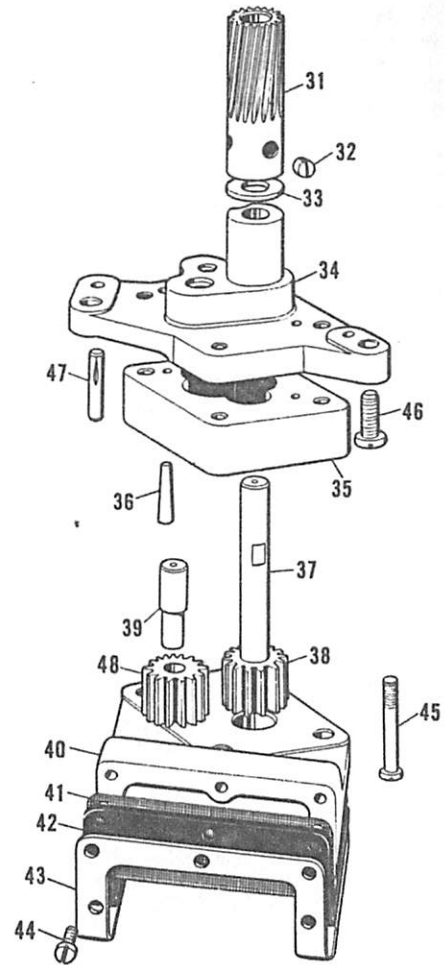
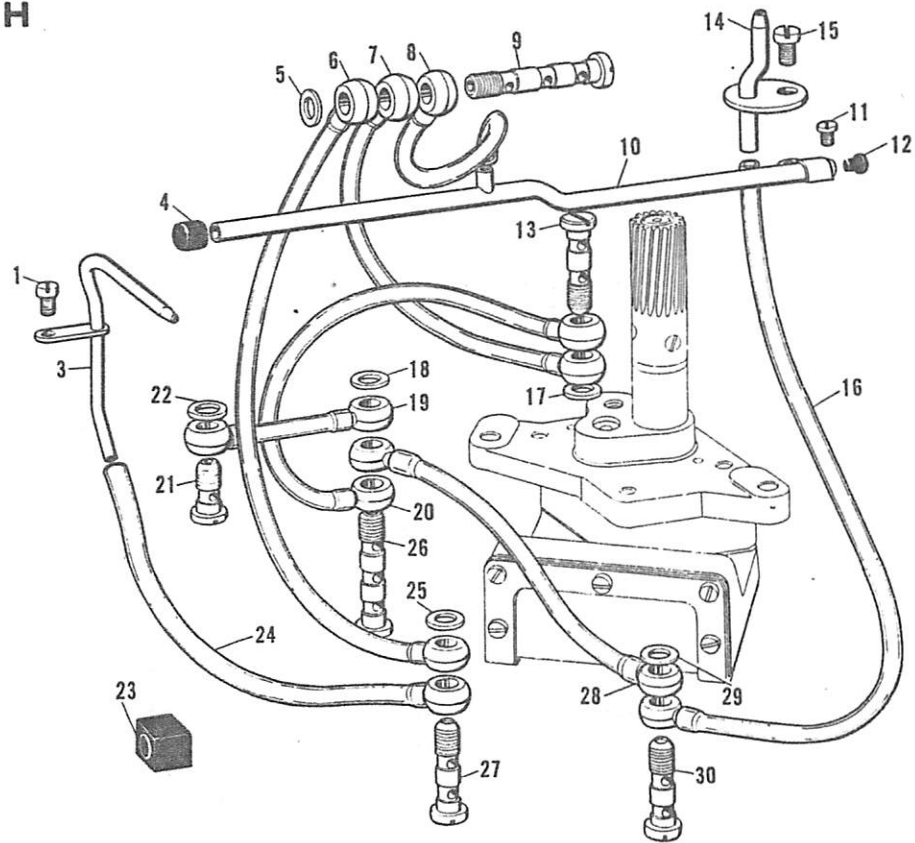



PARTS LIST for MA4-B972-5A and-5CA

H17

Ref. No.	Name of Parts	Q'ty	Parts No.	Assembly No.	Ref. No.	Name of Parts	Q'ty	Parts No.	Assembly No.
H-1	Set Screw for H-3	1 pce.	100185-0-03		H-47	Pin 3x16 for H-34	2 pcs.	508693-0-01	
H-3	Oil Pipe for Feed Rod	1 "	140764-0-01		H-48	Subordinate Pump Gear	1 pce.	140468-0-01	
H-4	Oil Cap	1 "	140325-0-01						
H-5	Packing for H-9	1 "	112348-0-01						
H-6	Vinyl Tube (A) 6φx230	1 "	140780-0-01						
H-7	Vinyl Tube (A) 6φx230	1 "	140780-0-01						
H-8	Vinyl Tube (B) 6φx180	1 "	140781-0-01						
H-9	Oil Feeding Pipe (A)	1 "	112351-0-01						
H-10	Main Oil Pipe	1 "	143534-0-01						
H-11	Set Screw for H-10	2 pcs.	100185-0-03						
H-12	Oil Cap	1 pce.	104833-0-01						
H-13	Oil Feeding Pipe (B)	1 "	112364-0-01						
H-14	Pilot Pipe	1 "	140314-0-01						
H-15	Set Screw for H-14	1 "	100541-0-01						
H-16	Vinyl Tube (C) 6φx230	1 "	140782-0-01						
H-17	Packing for H-13	1 "	112348-0-01						
H-18	Packing for H-26	1 "	112348-0-01						
H-19	Vinyl Tube (D) 6φx50	1 "	140778-0-01						
H-20	Vinyl Tube (A) 6φx230	1 "	140780-0-01						
H-21	Oil Feeding Screw	1 "	112359-0-01						
H-22	Packing for H-21	1 "	112348-0-01						
H-23	Tube Holder for H-24	1 "	140768-0-01						
H-24	Vinyl Tube (B) 6φx180	1 "	140781-0-01						
H-25	Packing for H-27	1 "	112348-0-01						
H-26	Oil Feeding Pipe (A)	1 "	112351-0-01						
H-27	Oil Feeding Pipe (B)	1 "	112364-0-01						
H-28	Vinyl Tube (E) 6φx80	1 "	140779-0-01						
H-29	Packing for H-30	1 "	112348-0-01						
H-30	Oil Feeding Pipe (B)	1 "	112364-0-01						
H-31	Worm Wheel	1 "	140301-0-00						
H-32	Set Screw for H-31	2 pcs.	100260-0-01						
H-33	Washer for H-31	1 pce.	107153-0-01						
H-34	Pump Body	1 "	140306-0-00						
H-35	Pump Case	1 "	140307-0-00						
H-36	Taper Pin 3x18 for H-35	2 pcs.	046301-8-20						
H-37	Main Pump Gear Shaft	1 pce.	140303-0-01						
H-38	Main Pump Gear	1 "	140305-0-01						
H-39	Subordinate Pump Shaft	1 "	140304-0-01	140302-0-01					
H-40	Pump Cover	1 "	140308-0-00						
H-41	Oil Filter Gauze	1 "	140309-0-00						
H-42	Pump Cover Packing	1 "	140310-0-01						
H-43	Oil Flange Filter	1 "	140311-0-00						
H-44	Set Screw for H-43	9 pcs.	100185-0-03						
H-45	Set Screw for H-40	4 "	140312-0-01						
H-46	Set Screw for H-34	2 "	105173-0-03						

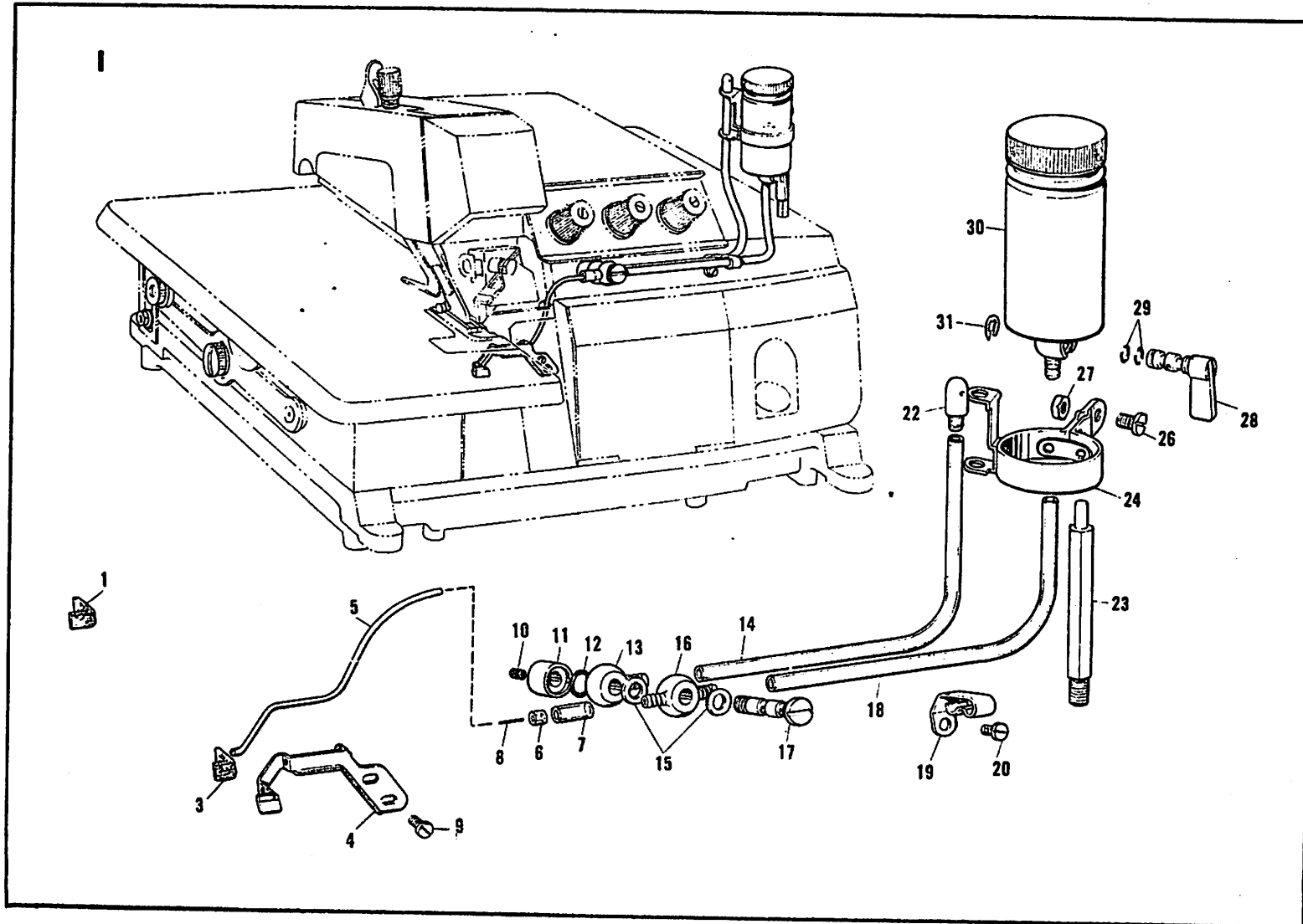



**PARTS LIST for MA4-B972-2<sub>A</sub> and 2C<sub>A</sub>**

J 20

This Chart shows the different parts from Model MA4-B972 -5<sub>A</sub> and 5C<sub>A</sub>  
Other parts are same as MA4-B972 -5<sub>A</sub> and 5C<sub>A</sub>

J	Ref. No.	Name of Parts	Q'ty	Parts No.	Assembly No.
	J- 1	Needle Clamp (2mm)	1 pce.	140988-0-01	142127-0-01
	J- 2	Needle Set Screw for J-1	2 pcs.	117666-0-01	
	J- 3	Sub-Presser Arm	1 pce.	142241-0-01	
	J- 4	Set Screw for J-5	1 "	114447-0-01	
	J- 5	Spring for J-9	1 "	142246-0-01	
	J- 6	Set Screw for J-7, 8	1 "	114447-0-01	142250-0-01
	J- 7	Stitch Tongue	1 "	142244-0-01	
	J- 8	Chip Guard	1 "	142245-0-01	
	J- 9	Presser Foot	1 "	142251-0-01	
	J-10	Set Pin for J-9	1 "	142243-0-01	
	J-11	Upper Knife (A)	1 "	142198-0-01	
	J-12	Upper Knife Clamp (A)	1 "	140456-0-01	
	J-13	Chain Stitch Needle Guard	1 "	140912-0-01	
	J-14	Needle Plate	1 "	142249-0-01	
	J-15	Main Feed Dog	1 "	142370-0-01	
	J-16	Differential Feed Dog	1 "	142371-0-01	
	J-17	Model Plate (B972 -2 <sub>A</sub> )	1 "	143279-0-01	
	J-18	Model Plate (B972 -2C <sub>A</sub> )	1 "	143280-0-01	
	J-19	Overlock Needle Guard	1 "	140108-0-02	



