

# PARTS BOOK

FOR

## BROTHER MD-933-943

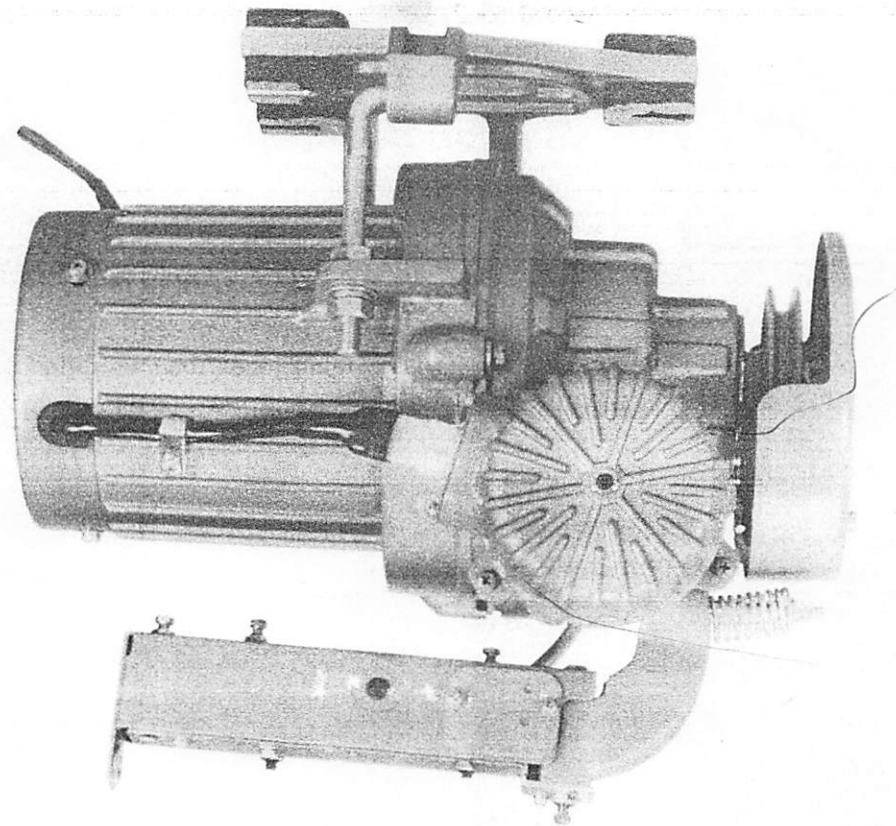

MOTOR

**BROTHER INDUSTRIES, LTD.**

NAGOYA, JAPAN

## Notes for using this parts book

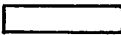
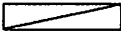
1. If the symbol  is found in the "Parts No." column or the "Assembly No." column, refer to the different parts list on page 5.
2. The symbol  in the "Parts No." column indicates that the parts is not available for supply. If however, there is a number in the "Assembly No." column, the parts can be ordered as an assembly. Please, therefore, order by using the Assembly No.
3. This book was prepared based on information available in February, 1980.
4. Parts are subject to changes in design without prior notice.

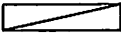

## Anmerkungen zum Gebrauch dieses Stücklistebuches

1. Dieses Zeichen  in der Spalte "Parts No. (Teilnummer)" oder "Assembly No. (Gerätesatznummer)" verweist auf die Gesonderte Stückliste auf Seite 5.
2. Dieses Zeichen  in der Spalte "Teilnummer" bedeutet, daß dieser Teil nicht lieferbar ist. Wenn jedoch in der Spalte "Gerätesatznummer" eine Nummer steht, kann dieser Teil als ein Geräteteilsatz bestellt werden. Bestellen Sie daher bitte mit dieser Gerätesatznummer.
3. Dieses Buch basiert auf den Informationen vom Februar, 1980.
4. Modelländerungen sind vorbehalten.

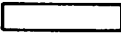
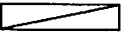
## Notes sur l'utilisation de ce manuel de pièces détachées

1. Si le symbole  se trouve dans la colonne "Parts No. (N° de pièce)" ou dans la colonne "Assembly No. (N° jeu de pcs)", veuillez vous référer à la liste de pièces annexe page 5.
2. Le symbole  dans la colonne "N° de pièce" signifie que la pièce ne peut être fournie. Si, dans la colonne "N° jeu de pcs", il y a un numéro de nomenclature, la pièce peut être commandée comme faisant partie d'un jeu de pièces. Donc, pour toute commande, veuillez spécifier le N° du jeu de pièces.
3. Ce manuel a été fait d'après les renseignements valables au mois de Fevrier, 1980.
4. Les pièces peuvent être sujetter à des modifications sans préavis.

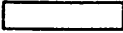
## Notas para usar este Libro de Piezas

1. De haber un símbolo  junto al "Parts No. (Número de Pieza)" o en la columna del "Assembly No. (Número de Juego)", habrá que mirar la lista de piezas separada de la página 5.
2. El símbolo , que se encuentra en la columna del "Número de Pieza", quiere decir que no se dispone de dicha pieza sola. Cuando, émpero, hay un número en la columna del "Numero de Juego", se podrá ordenar la pieza con todo el juego. Por lo tanto, será mejor hacer el pedido recurriendo al número del juego respectivo.
3. Este libro ha sido compilado basándose en los datos de que se disponía en Febrero de 1980.
4. Las piezas quedan sujetas a cambios de diseño sin aviso previo.

## CONTENTS

A. Synchronizer .....	1
B. Control Box .....	2
C. Motor (Part 1) .....	3
C. Motor (Part 2) .....	4
DIFFERENT PARTS LIST .....	5
INDEX .....	6

# A. Synchronizer

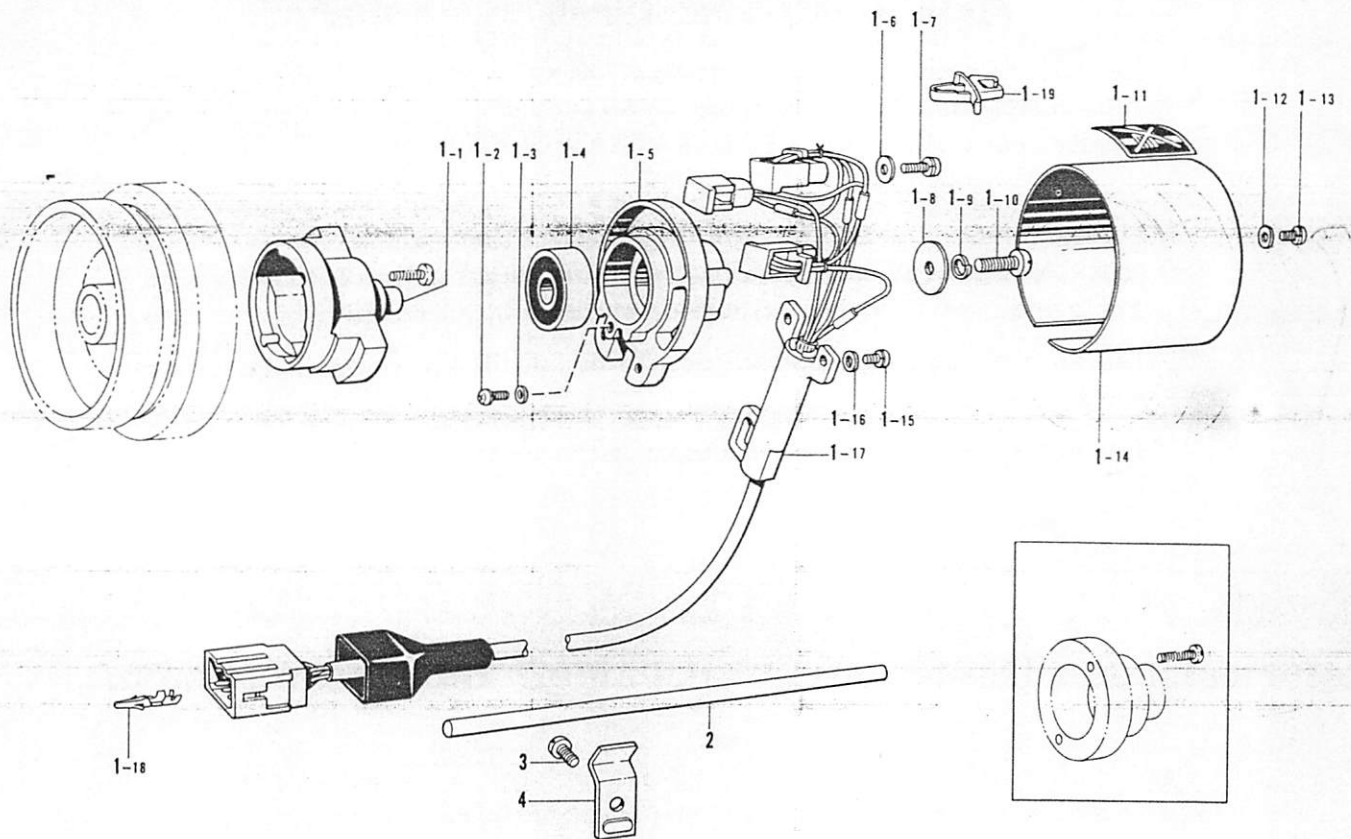

Ref. No.	Name of Parts	Q'ty	Parts No.	Assembly No.	Ref. No.	Name of Parts	Q'ty	Parts No.	Assembly No.
A-1- 1	Magnet Stud	1		A-1 Synchronizer Assembly #6-1 220067-0-01	A-1-11	Label	1		A-1 Synchronizer Assembly #6-1 220067-0-01
A-1- 2	Screw	1	215083-0-01		A-1-12	Washer	2	025040-3-35	
A-1- 3	Washer	1	025030-3-35		A-1-13	Screw	2	215080-0-01	
A-1- 4	Bearing	1			A-1-14	Synchronizer Cover	1		
A-1- 5	Hole IC Holder	1			A-1-15	Screw	2	215080-0-01	
A-1- 6	Washer	3	025040-3-35		A-1-16	Washer	2	025040-1-35	
A-1- 7	Screw	3	217093-0-01		A-1-17	Hole IC with Cord	1	218953-0-01	
A-1- 8	Washer	1	025060-3-35		A-1-18	Terminal Pin	4	216246-0-01	
A-1- 9	Spring Washer	1	028060-2-34		A-2	Screw	2	009711-4-12	
A-1-10	Screw	1	216880-0-01						

## B. Control Box

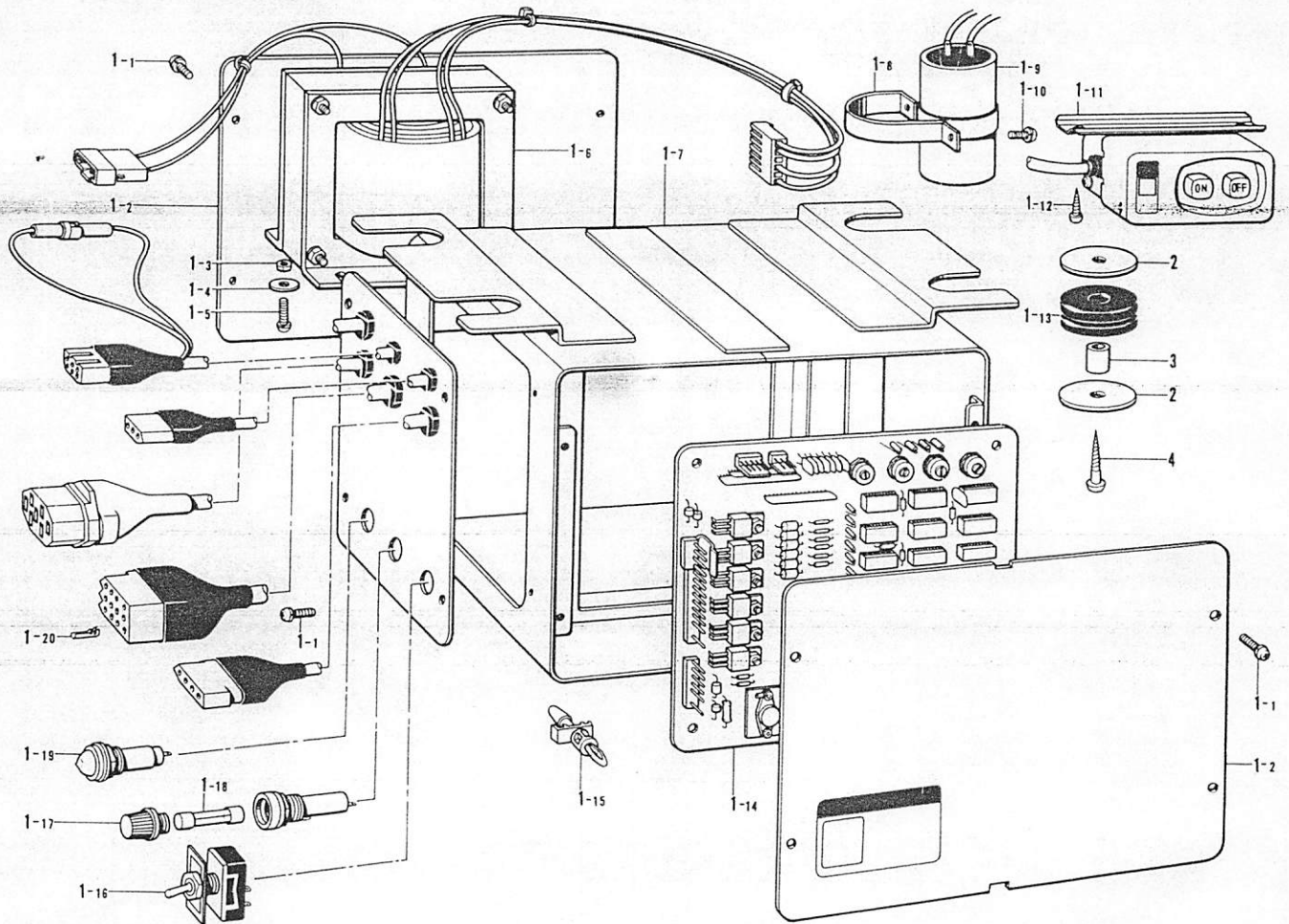

Ref. No.	Name of Parts	Q'ty	Parts No.	Assembly No.	Ref. No.	Name of Parts	Q'ty	Parts No.	Assembly No.
B-1- 1	Screw	12	215080-0-01	B-1 Control Box Assembly	B-1-13	Cushion Rubber	4	216345-0-01	B-1 Control Box Assembly
B-1- 2	Control Box Front Cover Plate	2	218819-0-01		B-1-14	Printed Circuit Board	1	221871-0-01	
B-1- 3	Nut	4	021400-2-05		B-1-15	Holder	4	220290-0-01	
B-1- 4	Washer	4	025040-3-35		B-1-16	Switich	1	216905-0-01	
B-1- 5	Screw	4	216870-0-01		B-1-17	Fuse Holder	1	215387-0-01	
B-1- 6	Transformer	1			B-1-18	5A Fuse	1	215822-0-00	
B-1- 7	Control Box	1			B-1-19	Pilot Lamp	1		
B-1- 8	Condenser Set Plate	1			B-1-20	Terminal Pin	27	216373-0-01	
B-1- 9	Condenser	1			B-2	Washer	8	214344-0-01	
B-1-10	Screw	2			B-3	Collar	4	216346-0-01	
B-1-11	3P Push Buttion Switch	1	213794-0-01		B-4	Screw	4	031624-0-05	
B-1-12	Screw	2	031451-6-03						

C. MOTOR (Part 1)

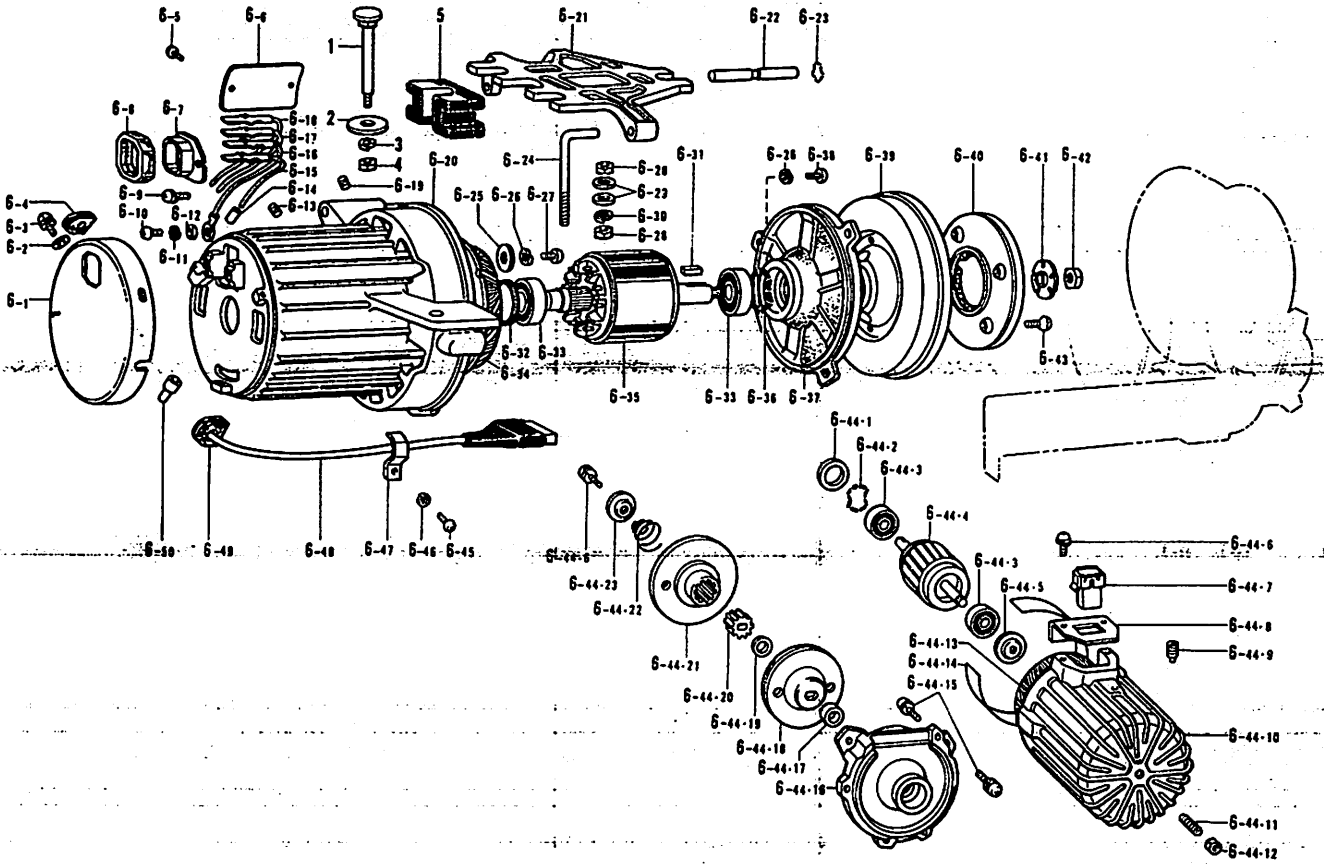

Ref. No.	Name of Parts	Q'ty	Parts No.	Assembly No.	Ref. No.	Name of Parts	Q'ty	Parts No.	Assembly No.
C-1	Bolt	3	210973-0-01		C-6-35	Rotor	1		C-6 Motor Assembly
C-2	Washer	3	213650-0-01		C-6-36	Washer	1	206156-0-01	
C-3	Washer	3	028080-2-43		C-6-37	Bracket	1	218871-0-01	
C-4	Nut	3	021080-1-06		C-6-38	Screw	3	220110-0-01	
C-5	Vibration Absorbing Rubber	3	213646-0-01		C-6-39	Fly Wheel	1		
C-6- 1	Frame Cover	1	218863-0-01		C-6-40	Clutch Lining #4	1	218873-0-01	
C-6- 2	Washer	3	025050-2-35		C-6-41	Washer	1	210941-0-02	
C-6- 3	Screw	3	211528-0-01		C-6-42	Nut	1	210942-0-02	
C-6- 4	Rubber Pad #72	1	218865-0-01		C-6-43	Screw	4	214897-0-01	
C-6- 5	Pin	2	200084-0-02		C-6-44- 1	Washer	2	218913-0-01	
C-6- 6	Model Plate	1			C-6-44- 2	Washer	3	218870-0-01	
C-6- 7	7P Socket	1	213748-0-01		C-6-44- 3	Bearing 608 VV	2	072060-8-60	
C-6- 8	7P Socket Cover 1	1	218862-0-01		C-6-44- 4	Roter	1		
C-6- 9	Screw	2	008400-8-06		C-6-44- 5	Roter Push Plate	1	218910-0-00	
C-6-10	Screw	1	002401-0-63		C-6-44- 6	Screw	3	215080-0-01	
C-6-11	Washer	1	028040-2-43		C-6-44- 7	3P Plug	1	216299-0-01	
C-6-12	Nut	1	025040-1-73		C-6-44- 8	Plug Set Plate	1	216300-0-01	
C-6-13	Screw	1	013080-8-13		C-6-44- 9	Screw	1	216286-0-01	
C-6-14	Vinyl Cap for Lead Wire	2	218951-0-01		C-6-44-10	Sub Motor Frame #55	1	218911-0-01	
C-6-15	Lead Wire (White)		218861-0-01	C-6 Motor Assembly	C-6-44-11	Screw	1	012061-8-22	C-6-44 Sub Motor Assembly
C-6-16	Lead Wire for Earth	1			C-6-44-12	Nut	1	021060-3-05	
C-6-17	Lead Wire (Red)	1	218861-0-02		C-6-44-13	Stator	1		
C-6-18	Lead Wire (Black)	1	218861-0-03		C-6-44-14	Insulator Paper	2	216284-0-00	
C-6-19	Screw	1	011060-6-13		C-6-44-15	Screw	3	211528-0-01	
C-6-20	Frame #54	1	218831-0-01		C-6-44-16	Bracket	1	218912-0-00	
C-6-21	Base	1	218874-0-01		C-6-44-17	Collar	1	218922-0-01	
C-6-22	Pin	1	215810-0-01		C-6-44-18	Clutch Plate	1	218916-0-01	
C-6-23	Washer	1	213765-0-01		C-6-44-19	Washer	1	218921-0-01	
C-6-24	Bolt Adjusting Rod	1	210965-0-01		C-6-44-20	Selation	1	217280-0-01	
C-6-25	Washer	3	213752-0-01	C-6-44-21	Round Plate	1	218918-0-01		
C-6-26	Spring Washer	3	028050-2-43	C-6-44-22	Spring	1	218919-0-01		
C-6-27	Screw	3	218905-0-01	C-6-44-23	Washer	1	218920-0-00		
C-6-28	Nut	2	021100-2-06	C-6-45	Screw	1	002500-8-06		
C-6-29	Washer	2	025100-2-36	C-6-46	Spring Washer	1	028050-2-43		
C-6-30	Washer	1	028100-2-43	C-6-47	Cord Holder	1	218866-0-01		
C-6-31	Key	1	210940-0-00	C-6-48	Plug for Sub Motor	1	218867-0-01		
C-6-32	Rubber Washer 0.8 x 35 x 40RU	1	210938-0-01	C-6-49	Rubber Pad #71	1	218864-0-01		
C-6-33	Bearing 6203 VV	2	072620-3-60	C-6-50	Crimp Connector	3	217169-0-00		
C-6-34	Stator	1							

# C. Motor (Part 2)

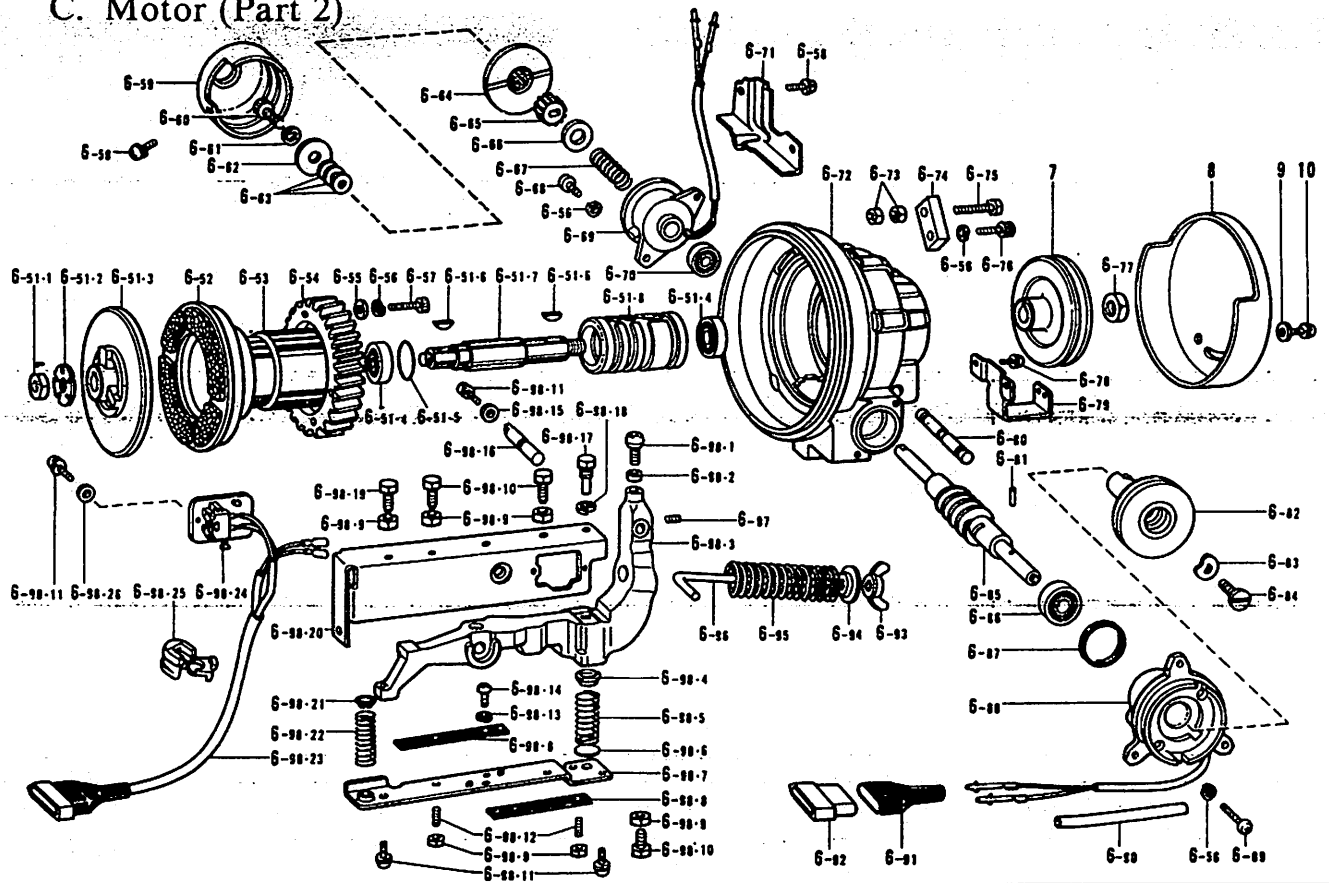

Ref. No.	Name of Parts	Q'ty	Parts No.	Assembly No.	Ref. No.	Name of Parts	Q'ty	Parts No.	Assembly No.
C-6-51- 1	Nut	1	210942-0-02	C-6-51 Clutch Plate #8 Assembly 218877-0-01	C-6-86	Bearing 6201 VV	1	072620-1-61	C-6 Motor Assembly
C-6-51- 2	Washer	1	210941-0-02		C-6-87	Washer	1	216277-0-01	
C-6-51- 3	Clutch Plate #6	1	213750-0-00		C-6-88	Clutch Solenoid	1	218903-0-01	
C-6-51- 4	Bearing 620 VV	2	072620-2-60		C-6-89	Screw	2	002503-5-05	
C-6-51- 5	Washer	1	210948-0-01		C-6-90	Vinyl Tube	1	216837-0-01	
C-6-51- 6	Key	2	210421-0-00		C-6-91	Plug Cover	1	216248-0-01	
C-6-51- 7	Clutch Shaft	1	218878-0-00		C-6-92	4P Plug	1	216247-0-01	
C-6-51- 8	Clutch Shaft Supporter	1	218879-0-00		C-6-93	Nut	1	206337-0-02	
C-6-52	Brake Lining	1	218882-0-01	C-6-94	Spring Cap	1	213760-0-01	C-6-98 Clutch Lever #8 Assembly 218923-0-01	
C-6-53	Supporter for Clutch Shaft Supporter	1	290439-0-00	C-6-95	Spring	1	218929-0-01		
C-6-54	Gear	1	216219-0-00	C-6-96	Pedal Pressure Adjusting Screw	1	218928-0-01		
C-6-55	Washer	4	025050-1-35	C-6-97	Screw	1	014061-0-22		
C-6-56	Spring Washer	9	028050-2-43	C-6-98- 1	Ball Screw	1	216225-0-01		
C-6-57	Bolt	4	018502-5-22	C-6-98- 2	Collar	1	218921-0-01		
C-6-58	Screw	4	215080-0-01	C-6-98- 3	Clutch Lever	1	218924-0-01		
C-6-59	Brake Cover	1	218902-0-01	C-6-98- 4	Spring Cap	1	216233-0-01		
C-6-60	Bolt	1	018401-4-22	C-6-98- 5	Spring	1	218945-0-01		
C-6-61	Spring Washer	1	028040-2-43	C-6-98- 6	Washer	1	216235-0-00		
C-6-62	Washer	1	218896-0-00	C-6-98- 7	Clutch Lever Bottom Plate	1	218946-0-01		
C-6-63	Spacer	4	219406-0-00	C-6-98- 8	Switch Presser Plate	2	216241-0-01		
C-6-64	Brake Disc	1	218895-0-01	C-6-98- 9	Nut	6	021060-3-05		
C-6-65	Selation	1	217280-0-01	C-6-98-10	Bolt	3	213913-0-01	C-6-98 Clutch Lever #8 Assembly 218923-0-01	
C-6-66	Washer	1	218894-0-01	C-6-98-11	Screw	8	215080-0-01		
C-6-67	Spring	1	218893-0-01	C-6-98-12	Screw	2	012061-2-22		
C-6-68	Screw	2	220110-0-01	C-6-98-13	Spring Washer	2	028040-2-43		
C-6-69	Brake Solenoid	1	218915-0-01	C-6-98-14	Screw	2	002400-6-05		
C-6-70	Bearing 608 VV	1	072060-8-60	C-6-98-15	Washer	1	025040-3-35		
C-6-71	Cord Holder	1	218930-0-01	C-6-98-16	Pin	1	218926-0-01		
C-6-72	Bracket	1	218876-0-01	C-6-98-17	Bolt	1	216232-0-01		
C-6-73	Nut	2	021060-3-05	C-6-98-18	Washer	1	028060-2-43		
C-6-74	Space Adjusting Plate	1	218881-0-01	C-6-98-19	Bolt	1	214002-0-01		
C-6-75	Bolt	1	219405-0-01	C-6-98-20	Clutch-Lever Cover	1	218925-0-01		
C-6-76	Bolt	1	018502-2-23	C-6-98-21	Spring Cap	1	218927-0-01		
C-6-77	Nut	1	210240-0-01	C-6-98-22	Spring	1	216230-0-01		
C-6-78	Screw	2	211528-0-01	C-6-98-23	Micro Key Cord	1	218947-0-01		
C-6-79	Belt Cover Set Plate	1	216380-0-01	C-6-98-24	Micro Switch	2	216236-0-01		
C-6-80	Pin	1	213757-0-02	C-6-98-25	Bushing	1	212544-0-01		
C-6-81	Spring Pin	1	218952-0-01	C-6-98-26	Washer	4	025040-1-35		
C-6-82	Clutch Plate #2	1	218885-0-01	C-7	Pulley	1			
C-6-83	Washer	1	218891-0-01	C-8	Belt Cover	1	215491-0-01		
C-6-84	Screw	1	218892-0-01	C-9	Washer	2	025050-3-35		
C-6-85	Worm	1	218884-0-00	C-10	Screw	2	211528-0-01		

## DIFFERENT PARTS LIST

Ref. No.	Name of Parts	Phase Volt	3 Phase				1 Phase				
			220V	380V	400V	400V (Lamp tap 12V)	110V	220V	240V	240V (Lamp tap 12V)	240V (W/O lamp tap)
B-1	Control Box Assembly	400	222122-0-01	222125-0-01	222128-0-01		222145-0-01	222148-0-01	222150-0-01		
		500	222136-0-01	222138-0-01	222140-0-01		222153-0-01	222155-0-01	222157-0-01		
		900	222159-0-01	/	/		/	222162-0-01	/		
B-1-6	Tranaformet		222123-0-00	222126-0-00	222129-0-00		222146-0-00	222123-0-00	222151-0-00		
B-1-8	Condenser Set Plate		/				219746-0-01				
B-1-9	Condenser		/				217775-0-00	217776-0-00			
B-1-10	Screw		/				215080-0-01				
B-1-19	Pilot Lamp		216364-0-00				217249-0-00	216364-0-00			
C-6	Motor Assembly		222171-0-01	222173-0-01	222174-0-01	222172-0-01	222212-0-01	222215-0-01	222216-0-01	222213-0-01	222214-0-01
C-6-15	Lead Wire (White)		2 Piece				1 Piece				
C-6-16	Lead Wire for Earth		213792-0-01				/	213792-0-01			
C-6-34	Stator		219485-0-00	219483-0-00	219935-0-00	219484-0-00	219985-0-00	219734-0-00	219968-0-00	219728-0-00	219792-0-00
C-6-35	Rotor		213802-0-01				219242-0-01				
C-6-39	Fly Wheel		218872-0-01				219729-0-01				
C-6-44	Sub Motor		219973-0-01	219499-0-01	219509-0-01		219986-0-01	219735-0-01	219730-0-01		
C-6-44-4	Roter		218907-0-01				219235-0-01				
C-6-44-13	Stator		219488-0-01	219486-0-00	219487-0-00		219987-0-00	219736-0-00	219731-0-00		

● Motor Pulley (Model DB2-B715)

Ref. No.	Name of Parts	Parts No.	Sewing Speed			
			50Hz		60Hz	
			High Speed	Slow Speed	High Speed	Slow Speed
C-7	Pulley K-80	217135-0-01	/	/	3650	170
	Pulley K-85	216922-0-0	/	/	3900	190
	Pulley K-90	216923-0-01	/	/	4150	200
	Pulley K-95	217136-0-01	/	/	4400	210
	Pulley K-100	216924-0-01	3800	180	/	/
	Pulley K-105	216925-0-01	4000	190	/	/
	Pulley K-110	212576-0-01	4200	200	/	/
	Pulley K-115	214404-0-01	4400	210	/	/



# INDEX

Parts No.	Ref. No.	Remark	Parts No.	Ref. No.	Remark	Parts No.	Ref. No.	Remark	Parts No.	Ref. No.	Remark
002400-6-05	C-6-98-14		213748-0-01	C-6-7		218861-0-03	C-6-18		220110-0-01	C-6-68	
002401-0-63	C-6-10		213750-0-00	C-6-51-3		218862-0-01	C-6-8		220290-0-01	B-1-15	
002500-8-06	C-6-45		213752-0-01	C-6-25		218863-0-01	C-6-1				
002503-5-05	C-6-89		213757-0-02	C-6-80		218864-0-01	C-6-49		221871-0-01	B-1-14	
008400-8-06	C-6-9		213760-0-01	C-6-94		218865-0-01	C-6-4		222122-0-01	B-1	
009711-4-12	A-2		213765-0-01	C-6-23		218866-0-01	C-6-47		222123-0-00	B-1-6	
012061-2-22	C-6-98-12		213792-0-01	C-6-16		218867-0-01	C-6-48		222125-0-01	B-1	
012061-8-22	C-6-44-11		213794-0-01	B-1-11		218870-0-01	C-6-44-2		222126-0-00	B-1-6	
013080-8-13	C-6-13		213802-0-01	C-6-35		218871-0-01	C-6-37		222128-0-01	B-1	
014061-0-22	C-6-97		213913-0-01	C-6-98-10		218872-0-01	C-6-39		222129-0-00	B-1-6	
018401-4-22	C-6-60		214002-0-01	C-6-98-19		218873-0-01	C-6-40		222136-0-01	B-1	
018502-2-23	C-6-76		214344-0-01	B-2		218874-0-01	C-6-21		222138-0-01	B-1	
018502-5-22	C-6-57		214404-0-01	C-7		218876-0-01	C-6-72		222140-0-01	B-1	
021060-3-05	C-6-44-12		214897-0-01	C-6-43		218877-0-01	C-6-51		222145-0-01	B-1	
	C-6-73		215080-0-01	A-1-13		218878-0-00	C-6-51-7		222146-0-00	B-1-6	
	C-6-98-9			A-1-15		218879-0-00	C-6-51-8		222148-0-01	B-1	
021080-1-06	C-4			B-1-1		218881-0-01	C-6-74		222150-0-01	B-1	
021100-2-06	C-6-28			B-1-14		218882-0-00	C-6-52		222151-0-00	B-1-6	
021400-2-05	B-1-3			C-6-44-6		218884-0-00	C-6-85		222153-0-01	B-1	
025030-3-35	A-1-3			C-6-58		218885-0-01	C-6-82		222155-0-01	B-1	
025040-1-35	A-1-16			C-6-98-11		218891-0-01	C-6-83		222157-0-01	B-1	
	C-6-98-26		215083-0-01	A-1-2		218892-0-01	C-6-84		222159-0-01	B-1	
025040-1-73	C-6-12		215387-0-01	B-1-17		218893-0-01	C-6-67		222162-0-01	B-1	
025040-3-35	A-1-6		215491-0-01	C-8		218894-0-01	C-6-66		222171-0-01	C-6	
	A-1-12		215810-0-01	C-6-22		218895-0-01	C-6-64		222172-0-01	C-6	
	B-1-4		215822-0-00	B-1-18		218896-0-00	C-6-62		222173-0-01	C-6	
	C-6-98-15		216219-0-00	C-6-54		218902-0-01	C-6-59		222174-0-01	C-6	
025050-1-35	C-6-55		216225-0-01	C-6-98-1		218903-0-01	C-6-88		222212-0-01	C-6	
025050-2-35	C-6-2		216230-0-01	C-6-98-22		218905-0-01	C-6-27		222213-0-01	C-6	
025050-3-35	C-9		216232-0-01	C-6-98-17					222214-0-01	C-6	
025060-3-35	A-1-8		216233-0-01	C-6-98-4		218907-0-01	C-6-44-4		222215-0-01	C-6	
025100-2-36	C-6-29		216235-0-00	C-6-98-6		218910-0-00	C-6-44-5		222216-0-01	C-6	
028040-2-43	C-6-11		216236-0-01	C-6-98-24		218911-0-01	C-6-44-10		290439-0-00	C-6-53	
	C-6-61		216241-0-01	C-6-98-8		218912-0-00	C-6-44-16				
	C-6-98-13		216246-0-01	A-1-18		218913-0-01	C-6-44-1		011060-6-13	C-6-19	
028050-2-43	C-6-26		216247-0-01	C-6-92					212576-0-01	C-7	
	C-6-46		216248-0-01	C-6-91		218915-0-01	C-6-69		219483-0-00	C-6-34	
	C-6-56		216277-0-01	C-6-87		218916-0-01	C-6-44-18		219484-0-00	C-6-34	
028060-2-34	A-1-9		216284-0-00	C-6-44-14		218918-0-01	C-6-44-21		219485-0-00	C-6-34	
028060-2-43	C-6-98-18		216286-0-01	C-6-44-9		218919-0-01	C-6-44-22		219486-0-00	C-6-44-13	
028080-2-43	C-3		216299-0-01	C-6-44-7		218920-0-00	C-6-44-23		219487-0-00	C-6-44-13	
028100-2-43	C-6-30		216300-0-01	C-6-44-8		218921-0-01	C-6-44-19		219488-0-00	C-6-44-13	
031451-6-03	B-1-12		216345-0-01	B-1-13			C-6-98-2		219499-0-01	C-6-44	
031624-0-05	B-4		216346-0-01	B-3		218922-0-01	C-6-44-17		219509-0-01	C-6-44	
072060-8-60	C-6-44-3		216364-0-00	B-1-19		218923-0-01	C-6-98		219728-0-00	C-6-34	
	C-6-70		216373-0-01	B-1-20		218924-0-01	C-6-98-3		219729-0-01	C-6-39	
072620-1-61	C-6-86		216380-0-01	C-6-79		218925-0-01	C-6-98-20		219730-0-01	C-6-44	
072620-2-60	C-6-51-4		216837-0-01	C-6-90		218926-0-01	C-6-98-16		219731-0-00	C-6-44-13	
072620-3-60	C-6-33		216870-0-01	B-1-5		218927-0-01	C-6-98-21		219734-0-00	C-6-34	
200084-0-02	C-6-5		216880-0-01	A-1-10		218928-0-01	C-6-96		219735-0-01	C-6-44	
206156-0-01	C-6-36		216905-0-01	B-1-16		218929-0-01	C-6-95		219736-0-00	C-6-44-13	
206337-0-02	C-6-93		216922-0-01	C-7		218930-0-01	C-6-71		219935-0-00	C-6-34	
210240-0-01	C-6-77		216923-0-01	C-7		218945-0-01	C-6-98-5		219968-0-00	C-6-34	
210421-0-00	C-6-51-6		216924-0-01	C-7		218946-0-01	C-6-98-7		219973-0-01	C-6-44	
210938-0-01	C-6-32		216925-0-01	C-7		218947-0-01	C-6-98-23		219985-0-00	C-6-34	
210940-0-00	C-6-31		217093-0-01	A-1-7		218951-0-01	C-6-14		219986-0-01	C-6-44	
210941-0-02	C-6-41		217135-0-01	C-7		218952-0-01	C-6-81		219987-0-00	C-6-44-13	
	C-6-51-2		217136-0-01	C-7		218953-0-01	A-1-17				
210942-0-02	C-6-42		217169-0-00	C-6-50							
	C-6-51-1		217249-0-00	B-1-19							
210948-0-01	C-6-51-5		217280-0-01	C-6-44-20							
210965-0-01	C-6-24			C-6-65							
210973-0-01	C-1		217775-0-00	B-1-9		219235-0-01	C-6-44-4				
211528-0-01	C-6-3		217776-0-00	B-1-9							
	C-6-44-15		218819-0-01	B-1-2		219242-0-01	C-6-35				
	C-6-78					219405-0-01	C-6-75				
	C-10		218831-0-01	C-6-20		219406-0-00	C-6-63				
212544-0-01	C-6-98-25					219746-0-01	B-1-8				
213646-0-01	C-5		218861-0-01	C-6-15		220067-0-01	A-1				
213650-0-01	C-2		218861-0-02	C-6-17		220110-0-01	C-6-38				